

M-16A INSTALLATION INSTRUCTIONS

UNPACKING

- 1) Open the box. If you have read this far you have already completed step 1. Go to step 2.
- 2) Remove the packing material from around the M-16A circuit board and inspect for obvious signs of damage due to shipping. If there is damage, save all packing material and notify the carrier.

HOW TO INSTALL

- 1) BE SURE YOUR SWTPC 6800 HAS BEEN COMPLETELY TESTED PRIOR TO INSTALLING THE M-16A. At a minimum, be sure the CPU board works with the on board 6810 RAM as outlined in the SWTPC instruction manual. IF THE SWTPC 6800 HAS NOT BEEN ASSEMBLED CORRECTLY, IT IS POSSIBLE TO SEVERELY DAMAGE THE M-16A.
- 2) The M-16A may be switch selected to begin at any 4K memory location. (0000hex, 1000hex, 2000hex etc). See the beginning location selection chart to determine the proper switch setting for your particular desired location. Note that although the M-16A can select any 4K starting location, not all locations are compatible with the SWTPC 6800. The M-16A occupies 4000hex or 16K of memory from the starting location. Thus, if you selected the board to begin at 1000hex, it would occupy 1000hex through 4FFFhex.
- 3) After selecting the desired starting location, check to be sure you have no other memory located in an area that overlaps the area selected for the M-16A.
- 4) WRITE PROTECT Turn the write protect switch S-1 to the up position. In the up position, write is enabled and you **can** read and write from the M-16A. In the down position, write is disabled and the M-16A functions as read only memory.
- 5) TURN OFF THE POWER TO THE SWTPC 6800. Installing the M-16A (or removing the M-16A) with the power applied may damage the components on the M-16A board.
- 6) Plug the M-16A into any of the 7 positions on the SWTPC 6800 mother board. Turn the power on and the system is ready to use. If you have more than 3 boards installed in the system, please read the following section on POWER SUPPLY CONSIDERATIONS.

POWER SUPPLY CONSIDERATIONS

While the power supply in the SWTPC 6800 will supply about 10 amps without overheating, it has been our experience that when drawing more than 4 amps, the voltage may drop below 7.5 volts. This is particularly true on the earlier units and with line voltages below 118 volts. While the M-16 will probably function satisfactorily with an input voltage below 7.5 volts, this is below the guaranteed operating voltage of the manufacturer of the voltage regulator. Therefore, we suggest the following test:

- 1) With all boards you normally use in your SWTPC 6800 installed and connected to their normal load in the case of I/O boards, measure the plus 8 volt unregulated supply at the Molex connector on the mother board. If the measured voltage is above 8 volts, no power supply modifications should be made.
- 2) If the measured voltage is below 7.5 volts, we strongly recommend that the supply be modified to increase the voltage.
- 3) If the voltage is between 7.5 and 8.0 volts, no modification is necessary unless the AC line voltage regularly falls 7 or 8 volts below the value of the line voltage at the time the measurement is made.

Again, everything should work properly even with a heavily loaded unmodified supply. Our philosophy, however, is to do everything possible (consistent with reasonable cost) to be sure your system operates reliably even under worst case conditions. Thus, we believe you should be aware of this potential problem in a heavily loaded system.

This is the end of the required reading in the instruction manual. The rest of the manual may or may not be of interest to you - read it if you wish.

WHAT MAKES IT TICK?

To the real hardware freak, it is probably intuitively obvious from the schematic diagram how the M-16A works. If you're not a digital logic crazy, however, you may wish to read further.

U-39 and U-40 are address buffers. They drive all 12 address lines to the 32 4K memory chips and connect to address lines A-0 through A-11 on the mother board. In addition to providing sufficient drive to the 32 memory chips without significantly loading the address lines on the motherboard, they provide important protection to the very expensive memory chips - both from transients on the motherboard and from static discharges during shipping and handling outside the motherboard.

U-33 and U-34 are bi-directional bus drivers. They perform a very similar function to the address buffers except that they buffer the data bus and swing either way depending on whether the CPU is performing a read or write to the memory board. When the CPU is neither reading from or writing to the memory board, these chips go tri-state - that is, they go into a high impedance mode and appear as an open circuit to the lines on either side of the chip.

U-1 through U-32 are the 4K memory chips. They are organized such that each combination of the 12 address lines access a unique 1 bit message within the chip. The chips are arranged in rows of 8 so that as each row is accessed a unique 8 bit byte is selected by the 12 address lines. Thus, each row contains 4096 8 bit bytes. The memory chip assignment table shows which memory chip contains each bit of information depending on what area of memory the bit of information is in. This is useful for trouble shooting.

For instance, let's assume that you run a memory diagnostic on the M-16A and that every time the diagnostic program tries to write a C0 into location 2300 hex in memory, it reads back a 40. From the Hexadecimal to Binary Conversion Table, we can see that bit 6 is being read as a one instead of a zero. From the Memory Chip Assignment Table, we can see that bit 6 of all memory locations between 2000 and 2FFF are contained in U-23 (Assuming an M-16A starting address of 0000. If the starting address were 1000, then it would be U-15.) This would usually indicate that U-23 is defective and should be replaced. If, however, each time a C0 was written into any memory location between 0000 and 3FFF a 40 was read back, it is highly unlikely that U-7, U-15, U-23, and U-31 would all be defective. Thus, it would be more likely that U-34 which drives bit 6 to and from the data bus would be defective.

U-36 determines the direction of the data bus drivers from the data on the read/write line and the outputs of U-35 and U-38. U-35 is an adder hooked up as a subtracter to have its outputs at pins 13 and 10 both low any time the board is selected as determined by the switch positions. Pins 4 and 1 feed the row select information to U-37 which decodes this information and enables the selected row for read or write operation.

U-41 is a 5 volt 3 amp voltage regulator. Normally the M-16A draws about 1.8 amps so this regulator is well within its current rating.

LIMITED WARRANTY

Smoke Signal Broadcasting will repair or replace any defective M-16A returned to it within 90 days of purchase provided that, in our opinion, the damage or defect was not caused by a malfunction in the computer or other device in which it was installed and that it was not mishandled. Our warranty extends to repair or replacement only and we will not be liable for any consequential damages incurred by the user of an M-16A.

REPAIRS

Outside of the 90 day warranty period, there is flat \$25 rate for repairs to the M-16A provided that there is no physical damage to the circuit board and that no more than one memory chip needs to be replaced. To return a board for repair, enclose a check for \$25 with the board and mail to:

Smoke Signal Broadcasting
31336 Via Colinas
Westlake Village, Ca. 91361

If the board does not qualify for the \$25 flat rate, you will be notified and an estimate given before any work is done on the board. Otherwise, it will be repaired promptly and returned.

HEXADECIMAL TO BINARY CONVERSION TABLE
FOR NUMBERS CONTAINING ONLY ONE BIT SET TO LOGIC LEVEL ONE

HEXADECIMAL NUMBER	BINARY EQUIVALENT NUMBER							
	BIT 7	BIT 6	BIT 5	BIT 4	BIT 3	BIT 2	BIT 1	BIT 0
00	0	0	0	0	0	0	0	0
01	0	0	0	0	0	0	0	1
02	0	0	0	0	0	0	1	0
04	0	0	0	0	0	1	0	0
08	0	0	0	0	1	0	0	0
10	0	0	0	1	0	0	0	0
20	0	0	1	0	0	0	0	0
40	0	1	0	0	0	0	0	0
80	1	0	0	0	0	0	0	0

BEGINNING ADDRESS SELECTION CHART

SWITCH POSITIONS				BEGINNING ADDRESS	ENDING ADDRESS
S2	S3	S4	S5		
--	--	--	--	-----	-----
DN	DN	DN	DN	0000	3FFF
DN	DN	DN	UP	1000	4FFF
DN	DN	UP	DN	2000	5FFF
DN	DN	UP	UP	3000	6FFF
DN	UP	DN	DN	4000	7FFF
UP	DN	UP	DN	8000	8FFF **

** TO USE THE M-16H AT THIS LOCATION, IT IS NECESSARY TO MAKE THE FOLLOWING MODIFICATIONS TO THE SWTPC 6800 CPU BOARD.

- 1) CUT THE FOIL BETWEEN PINS 10 AND 13 OF IC 16 ON THE SWTPC 6800 CPU BOARD.
- 2) ADD A JUMPER BETWEEN IC 7 PIN 3 AND IC 16 PIN 13.

IT IS NOT NECESSARY TO REMOVE THE 6810 RAM, HOWEVER, IT IS NOT USED WHEN USING THE M-16H AT 8000 THROUGH 8FFF SO IT MAY BE REMOVED IF YOU LIKE.

THE M-16H MAY BE SWITCH SELECTED TO LOCATIONS OTHER THAN THOSE INDICATED ON THE CHART, HOWEVER THE LOCATIONS GIVEN ARE THE ONLY ONES EASILY COMPATIBLE WITH THE SWTPC 6800. TO DETERMINE OTHER LOCATIONS, THE SWITCHES READ THE BEGINNING ADDRESS IN BINARY WITH S5 BEING THE LEAST SIGNIFICANT BIT.

MEMORY CHIP ASSIGNMENT TABLE

STARTING ADDRESS PLUS	STARTING ADDRESS PLUS	BIT 7	BIT 6	BIT 5	BIT 4	BIT 3	BIT 2	BIT 1	BIT 0	
0000	THRU	0FFF	IC-8	IC-7	IC-6	IC-5	IC-4	IC-3	IC-2	IC-1
1000	THRU	1FFF	IC-16	IC-15	IC-14	IC-13	IC-12	IC-11	IC-10	IC-9
2000	THRU	2FFF	IC-24	IC-23	IC-22	IC-21	IC-20	IC-19	IC-18	IC-17
3000	THRU	3FFF	IC-32	IC-31	IC-30	IC-29	IC-28	IC-27	IC-26	IC-25

Indicates connection to designated pin number U1 thru U32

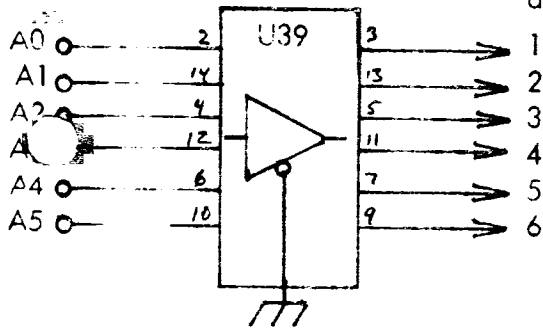

SMOKE SIGNAL BROADCASTING
HOLLYWOOD, CA.
M-16A SCHEMATIC DIAGRAM
© 1977

Parts List

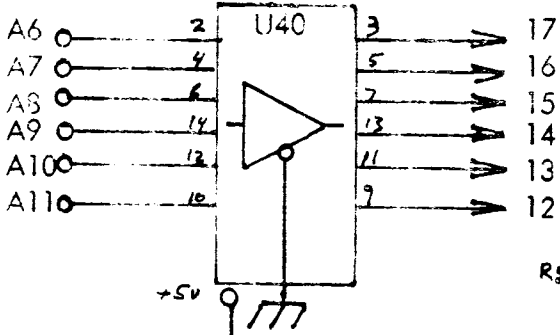

U1 thru U32	TMS4044	C1-C2	10uf 16vdc
U33 and U34	8835	C3-C12	.047uf
U35	74LS283	R1-R5	1K 1/4w
U36	7410	U41	LM323K
U37	74S138	S1-S5	76B05
U38	7402		
U39 and U40	8097		

