

P-197 Power Supply Board Assembly

The P-197 is a +5.0 volt @ 2.25 Amp, -5 volt @ 20 mA, -12 volt @ 60 mA, DC power supply. The +5 volt regulation is typically better than 2% over the specified current range which is well within TTL requirements. The unit is also temperature compensated to a point which should be more than satisfactory for operation within any reasonable temperature environment.

Construction

- () Clean the copper foil on the circuit board with a piece of Scotchbrite (available at most hardware stores) to remove any oxidation.
- () Mount all of the components on the board excluding transistor Q3. Use the parts list and printing on the top of the board to locate the proper position of each part. Mount the components flush with the top of the board, bend the leads parallel to the board on the foil side, and trim so that 1/16" to 1/8" of wire remains. Transistor, Q1 should be attached so that its case is about 1/8" above the top of the board.

Be sure to orient all diodes, transistors, and electrolytic capacitors as indicated by the printing on the component side of the board. Solder.

- () Transistor, Q3, must be mounted so the copper side of the transistor faces away from the bottom side of the circuit board. Bend the leads on Q3 at right angles away from the copper side of the transistors. Make the bend 11/32" from the plastic case on the center lead and 3/16" from the plastic case on the two side leads. The transistor should be inserted from the bottom side of the board and the leads soldered when the distance from the copper face side of the transistor to the bottom of the circuit board is 1/4".
- () Attach and solder all of the wires to the P-197 board with the exception of the transformer secondary wires. All of the wires should be inserted from the component side and soldered on the foil side of the board. Use the following table for wire connection reference. The opposite ends of the wires are in turn attached to the female connector pins which are in turn inserted into their correct position in the six pin plug-on connector from the numbered side. Try to keep the total length of the wiring harness under 12".

	<u>GAUGE</u>	<u>FROM</u>	<u>TO</u>
1.	#18 or heavier	+5	connector pin #2 of J11
2.	#18 or heavier	GND	connector pin #3 & 6 of J11
3.	#18 or heavier	GND	chassis ground
4.	#22 or heavier	-5	connector pin #4 of J11
5.	#22 or heavier	-12	connector pin #1 of J11
6.	#22 or heavier	REF	connector pin #5 of J11

- () Attach and solder the six transformer secondary leads to the board. The two solid green leads and the green lead with a tracer should be attached and soldered to the two points marked "G" and the point marked "G-T" respectively. The solid red leads and the red lead with a tracer should be attached and soldered to the two points marked "B" and the point marked "B-T" respectively.
- () Attach the board to your chassis. Since the wiring harness should be no longer than 12", the power supply should be mounted as close to the main board as possible. The metal face of transistor Q3 is internally connected to the transistor's collector lead and must be electrically isolated from the chassis to which it is attached. The power supply also depends upon the chassis to which is attached to dissipate the heat that is generated in transistor Q3. So Q3 must be attached to a piece of metal with at least 25 sq. in. of surface area mounted vertically for optimum dissipation. Either a metal chassis or heat sink may be used. Sandwich the rubber insulating washer between transistor Q3 and the chassis when attaching the transistor end of the board. Attach the other end of the board using #4 x 40 x 1/2" screws, 1/4" spacers and nuts.
- () Attach the transformer, T1, to your chassis. Use #6-32 x 1/4" screws, lockwashers, and nuts.
- () Connect the primary leads for either 110, or 220 Volt operation as may be required. For 110 Volt operation Black lead to the Red-Black lead and the White lead to the White-Black lead. These two wires connect to the line. For 220 Volt operation, connect the White lead to the Red-Black lead. Tape, or insulate this connection. Connect the line to the Black and Black-White leads.

- () The power supply must be tested and calibrated before connecting the supply to the main terminal board. You must make absolutely sure that all of the connections have been made to the correct pin on the power connector. A mistake here could be costly so be careful and check for proper voltages right at the connector. First of all set trimmer resistor R4 so the tab on the knurl of the control faces transistor Q1. With power applied, measure the +5 DC voltage at the connector (pin 2 with respect to chassis ground). Advance the knurl of the trimmer resistor, R4, until the voltmeter reads 5.0 volts. Leave the trimmer resistor set in this position for further operation. Also check to make sure the -5 VDC (pin 4) and -12 VDC (pin 1) outputs are within 10% of the correct voltage. Check the 6 VAC Reference (pin 5) as well for proper output. Remove power, disconnect the meter and return to the keyboard assembly phase of the terminal instructions.

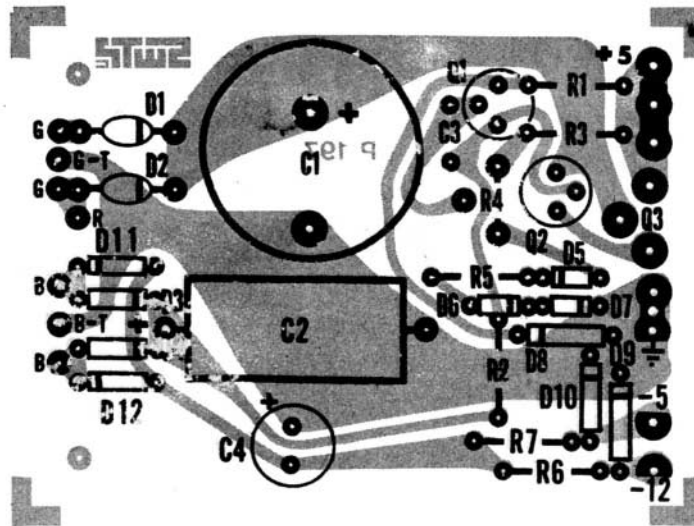

Schematic - P197 Power Supply

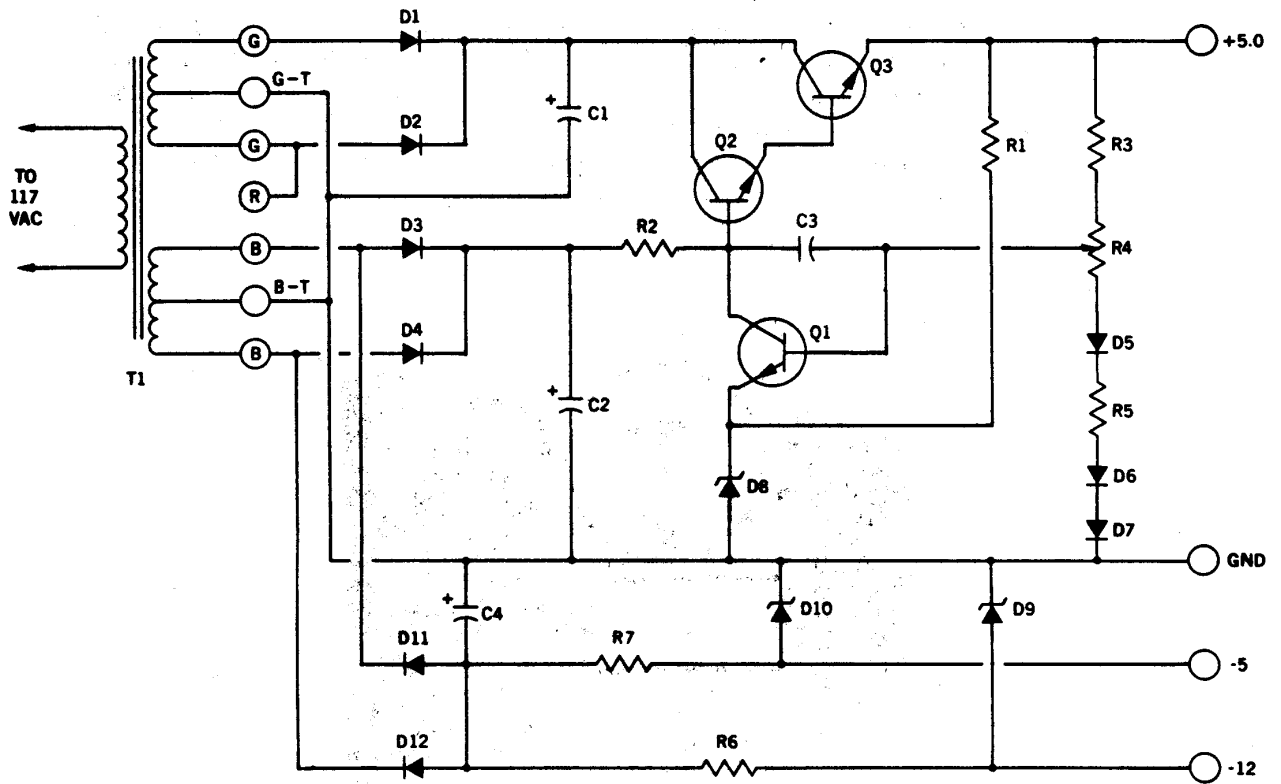

Parts List – P197 Power Supply (CT-P)

Resistors

R1	39 ohm 1/2 watt 10% resistor
R2	680 ohm 1/2 watt 10% resistor
R3	68 ohm 1/2 watt 10% resistor
R4	250 ohm trimmer resistor
R5, R6	150 ohm 1/2 watt 10% resistor
R7	1.0K ohm 1/2 watt 10% resistor

Semiconductors

D1, D2	3 amp rectifier – 1N5402 or equal
D3, D4, D11, D12	1 amp rectifier – 1N4003 or equal
D5 – D7	1N4148 silicon diode or equiv.
D8	3.3 volt zener diode 1N4728 or equiv.
D9	12 volt zener diode 1N4742 or equiv.
D10	5.1 volt zener diode 1N 4733 or equiv.

Capacitors

C1	5000 mfd @10 VDC electrolytic capacitor
C2	470 mfd @25 VDC electrolytic capacitor
C3	0.01 mfd capacitor
C4	100 mfd @25 VDC electrolytic capacitor

Misc.

T1	Power transformer – 36 P 46
----	-----------------------------

Transistors

Q1	2N5129 silicon transistor
Q2	SS1123 silicon transistor
Q3	MJE3055 silicon transistor

Note: The MJE3055 transistor is in a TO-127 package (shown). The common MJE3055T is in a TO-220 package which swaps the Emitter and Base

