



**MOTOROLA**  
Semiconductors

**MC1506L**  
**MC1406L**

**Specifications and Applications Information**

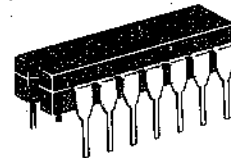
**SIX BIT, MULTIPLYING DIGITAL-TO-ANALOG CONVERTER**

... designed for use where the output current is a linear product of a six-bit digital word and an analog input voltage.

- Digital Inputs are MDTL and MTTL Compatible
- Relative Accuracy —  $\pm 0.78\%$  Error maximum
- Low Power Dissipation — 85 mW typical @  $\pm 5.0$  V
- Adjustable Output Current Scaling
- Fast Settling Time — 150 ns typical
- Standard Supply Voltage: +5.0 V and -5.0 V to -15 V

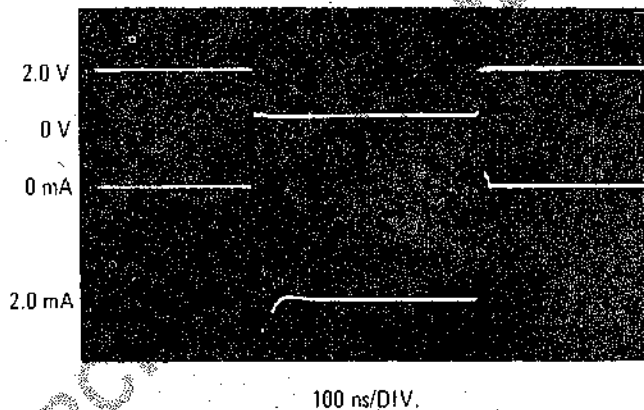
**SIX BIT, MULTIPLYING DIGITAL-TO-ANALOG CONVERTER**

**SILICON MONOLITHIC INTEGRATED CIRCUIT**

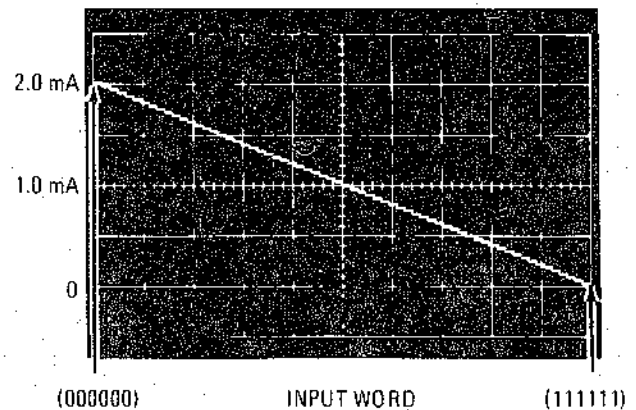


CERAMIC PACKAGE  
CASE 632  
TO-116

**FIGURE 1 — OUTPUT CURRENT SETTLING TIME (ALL BITS SWITCHED,  $R_L = 50 \Omega$ )**



**FIGURE 2 — D-to-A TRANSFER CHARACTERISTICS**



**TYPICAL APPLICATIONS**

- Tracking A-to-D Converters
- Successive Approximation A-to-D Converters
- Digital-to-Analog Meter Readout
- Sample and Hold
- Peak Detector
- Programmable Gain and Attenuation
- Digital Varicap Tuning
- Video Systems
- Stepping Motor Drive
- CRT Character Generation
- Digital Addition and Subtraction
- Analog-Digital Multiplication
- Digital-Digital Multiplication
- Analog-Digital Division
- Programmable Power Supplies
- Speech Encoding

MAXIMUM RATINGS ( $T_A = +25^\circ\text{C}$  unless otherwise noted.)

Rating	Symbol	Value	Unit
Power Supply Voltage	$V_{CC}$ $V_{EE}$	+5.5 -16.5	Vdc
Digital Input Voltage	$V_5$ thru $V_{10}$	+8.0, $V_{EE}$	Vdc
Applied Output Voltage	$V_O$	$\pm 5.0$	Vdc
Reference Current	$I_{12}$	5.0	mA
Reference Amplifier Inputs	$V_{12}, V_{13}$	$V_{CC}, V_{EE}$	Vdc
Power Dissipation (Package Limitation) Ceramic Package Derate above $T_A = +25^\circ\text{C}$	$P_D$	1000 6.7	mW mW/ $^\circ\text{C}$
Operating Temperature Range	$T_A$	-55 to +125 0 to +70	$^\circ\text{C}$
	MC1506L MC1406L		
Storage Temperature Range	$T_{stg}$	-65 to +150	$^\circ\text{C}$

Characteristic	Figure	Symbol	Min	Typ	Max	Unit
Relative Accuracy (Error relative to full scale $I_O$ )	10	$E_r$	-	-	$\pm 0.78$	%
Settling Time (within 1/2 LSB (includes $t_d$ ) $T_A = +25^\circ\text{C}$ )	9	$t_s$	-	150	300	ns
Propagation Delay Time $T_A = +25^\circ\text{C}$	9	$t_{PHL}$ $t_{PLH}$	-	10	50	ns
Output Full Scale Current Drift		$ TCI_O $	-	80	-	PPM/ $^\circ\text{C}$
Digital Input Logic Levels High Level, Logic "1" Low Level, Logic "0"	3,14	$V_{IH}$ $V_{IL}$	2.4 -	- -	- 0.8	Vdc
Digital Input Current High Level, $V_{IH} = 5.0$ V Low Level, $V_{IL} = 0.8$ V	3,13	$I_{IH}$ $I_{IL}$	- -	0 -0.7	+0.01 -1.5	mA
Reference Input Bias Current (Pin 13)	3	$I_{13}$	-	-0.002	-0.01	mA
Output Current Range $V_{EE} = -5.0$ V $V_{EE} = -6.0$ to $-15$ V	3	$I_{OR}$	0 0	2.0 2.0	2.1 4.2	mA
Output Current $V_{ref} = 2.000$ V, $R_{12} = 1.000$ k $\Omega$	3	$I_O$	1.9	1.97	2.1	mA
Output Current (all bits high)	3	$I_O(\text{min})$	-	0	10	$\mu\text{A}$
Output Voltage Compliance ( $E_r \leq \pm 0.78\%$ at $T_A = +25^\circ\text{C}$ )	3,4,5	$V_{O+}$ $V_{O-}$	- -	+0.25 -0.45	+0.1 -0.3	Vdc
Reference Current Slew Rate ( $T_A = +25^\circ\text{C}$ )	8,15	SR $I_{ref}$	-	2.0	-	mA/ $\mu\text{s}$
Output Current Power Supply Sensitivity	10	PSRR (-)	-	0.002	0.010	mA/V
Power Supply Current $A_1$ thru $A_6$ ; $V_{IL} = 0.8$ V $A_1$ thru $A_6$ ; $V_{IH} = 2.4$ V	3,11,12	$I_{CC}$ $I_{EE}$	- -	+7.2 -9.0	+11 -11	mA
Power Dissipation (all bits high) $V_{EE} = -5.0$ Vdc $V_{EE} = -15$ Vdc		$P_D$	- -	85 175	120 240	mW

\* $T_{high} = +70^\circ\text{C}$  for MC1406L     $T_{low} = 0^\circ\text{C}$  for MC1406L  
 $= +125^\circ\text{C}$  for MC1506L        $= -55^\circ\text{C}$  for MC1506L



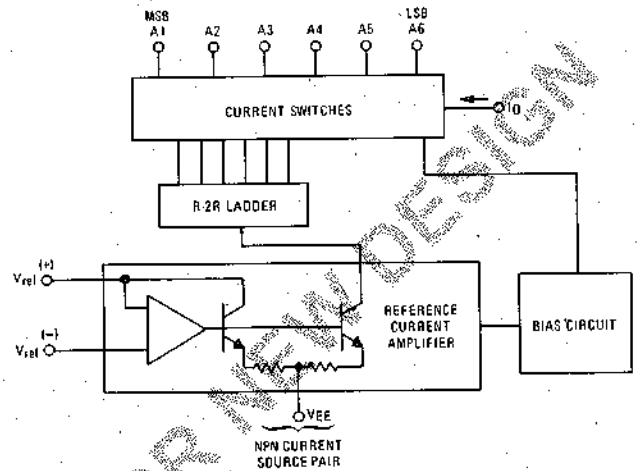
MOTOROLA Semiconductor Products Inc.

The MC1506L consists of a reference current amplifier, an R-2R ladder, and six high-speed current switches. For many applications, only a reference resistor and a reference supply voltage need be added.

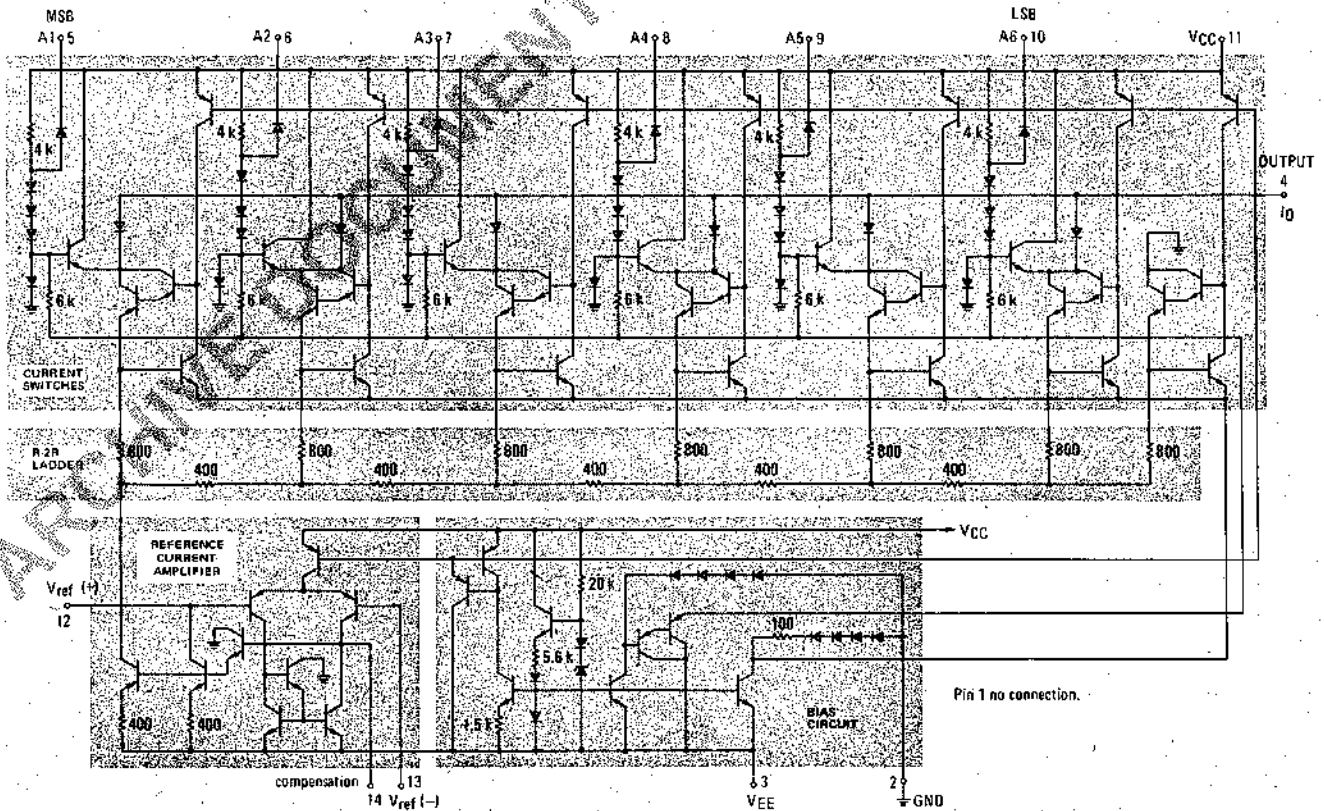
The switches are inverting in operation, therefore a low state at the input turns on the specified output current component. The switches use a current steering technique for high speed and a termination amplifier that consists of an active load gain stage with unity gain feedback. The termination amplifier holds the parasitic capacitance of the ladder at a constant voltage during switching and provides a low impedance termination of equal voltage for all legs of the ladder.

The R-2R ladder divides the reference amplifier current into binary-related components which are fed to the switches. Note that there is always a remainder current that is equal to the least significant bit. This current is shunted to ground, and the maximum current is 63/64 of the reference amplifier current, or 1.969 mA for a 2.0 mA reference current if the NPN current source pair is perfectly matched.

**BLOCK DIAGRAM**



**COMPLETE CIRCUIT SCHEMATIC**  
(Digital inputs, pins 5,6,7,8,9,10)



TEST CIRCUITS AND TYPICAL CHARACTERISTICS

FIGURE 3 – NOTATION DEFINITIONS TEST CIRCUIT

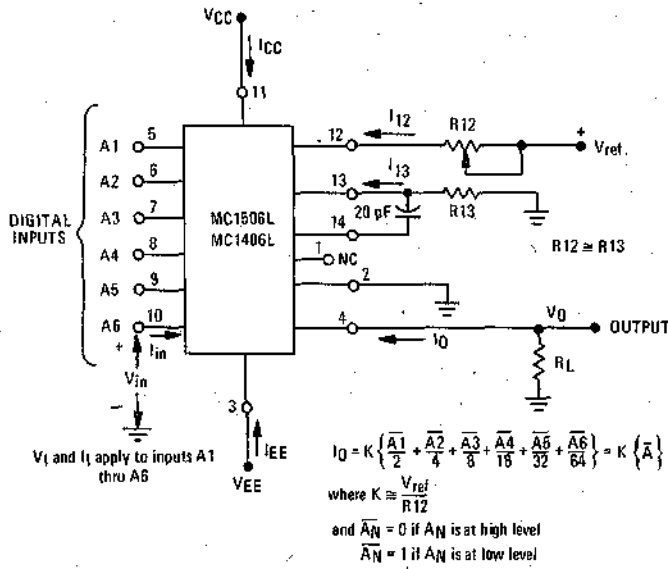


FIGURE 4 – OUTPUT CURRENT versus OUTPUT VOLTAGE

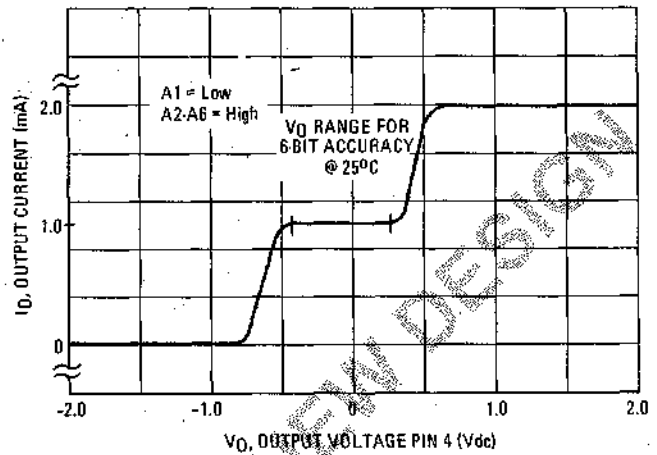


FIGURE 5 – MAXIMUM OUTPUT VOLTAGE versus TEMPERATURE

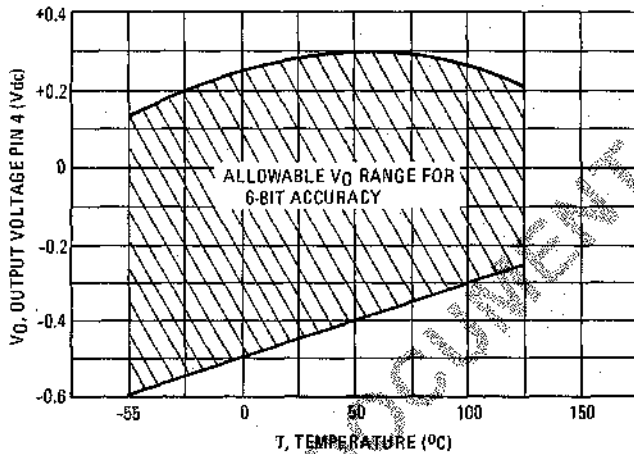


FIGURE 6 – POSITIVE V<sub>ref</sub>

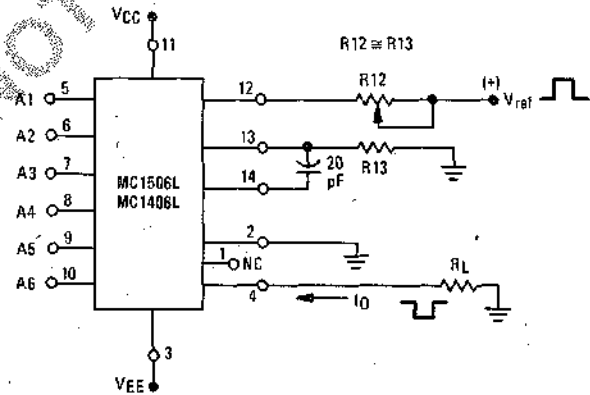


FIGURE 8 – REFERENCE CURRENT SLEW RATE MEASUREMENT TEST CIRCUIT

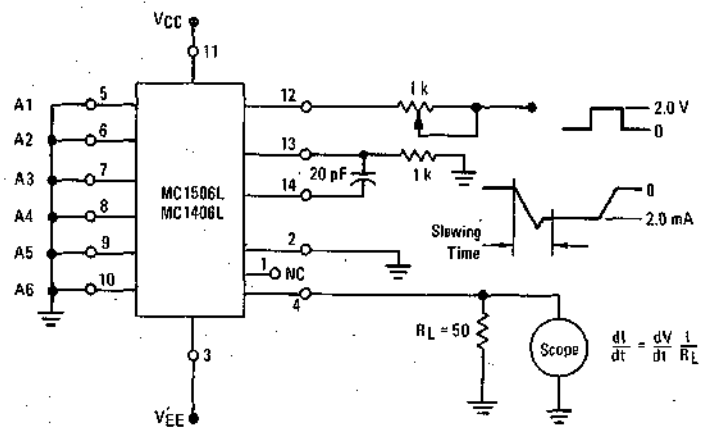
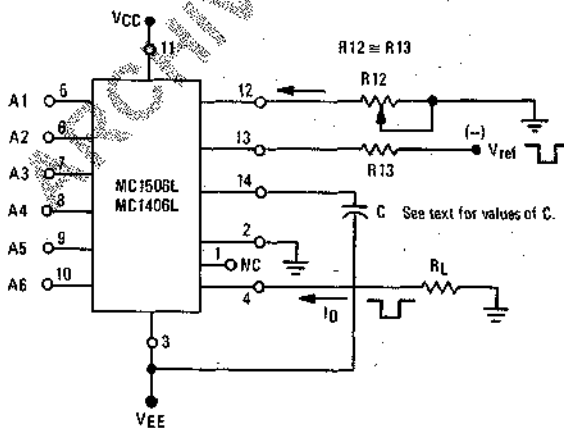


FIGURE 7 – NEGATIVE V<sub>ref</sub>



TEST CIRCUITS and TYPICAL CHARACTERISTICS (continued)

FIGURE 9 – TRANSIENT RESPONSE

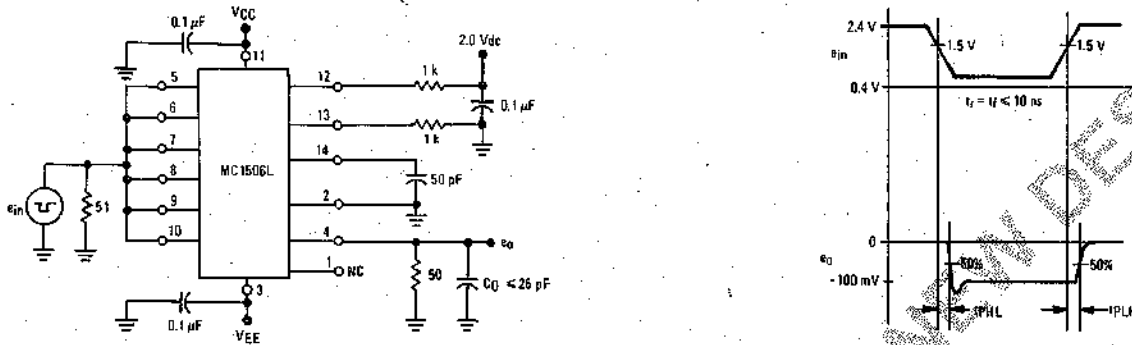


FIGURE 10 – RELATIVE ACCURACY TEST CIRCUIT

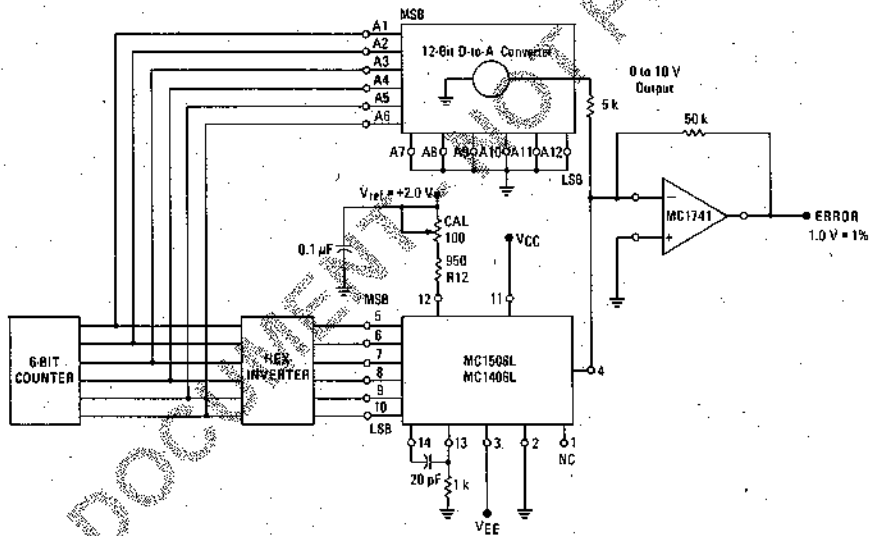


FIGURE 11 – TYPICAL POWER SUPPLY CURRENT versus TEMPERATURE

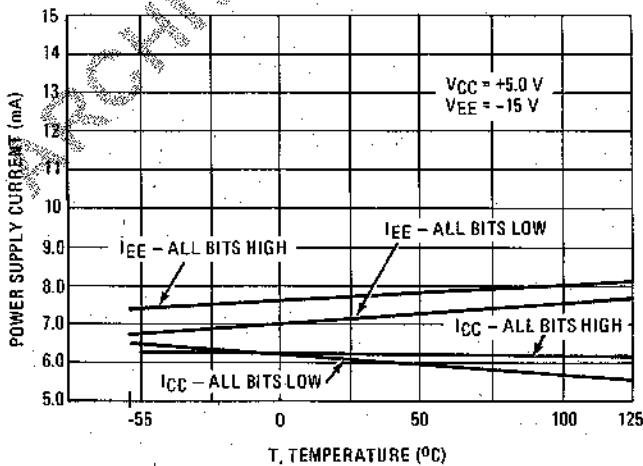
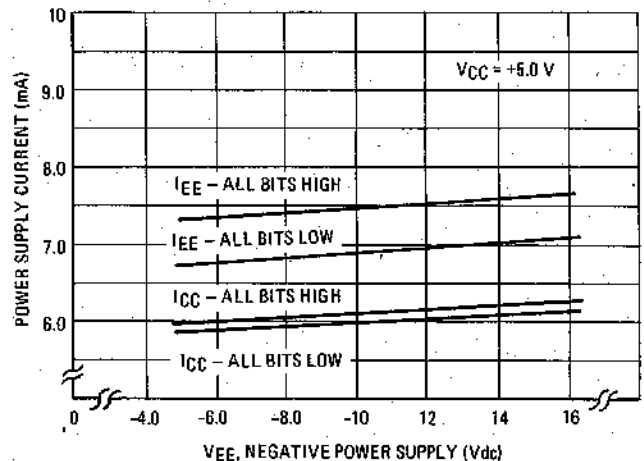


FIGURE 12 – TYPICAL POWER SUPPLY CURRENT versus VEE



TYPICAL CHARACTERISTICS (continued)

GENERAL INFORMATION

FIGURE 13 — LOGIC INPUT CURRENT versus INPUT VOLTAGE

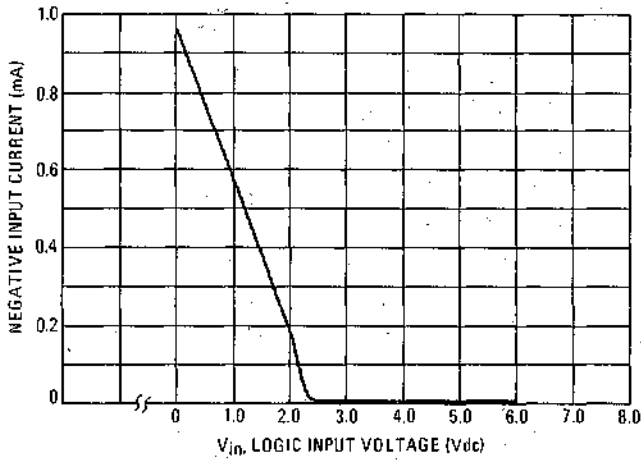


FIGURE 14 — MSB TRANSFER CHARACTERISTICS versus TEMPERATURE (MSB IS "WORST CASE")

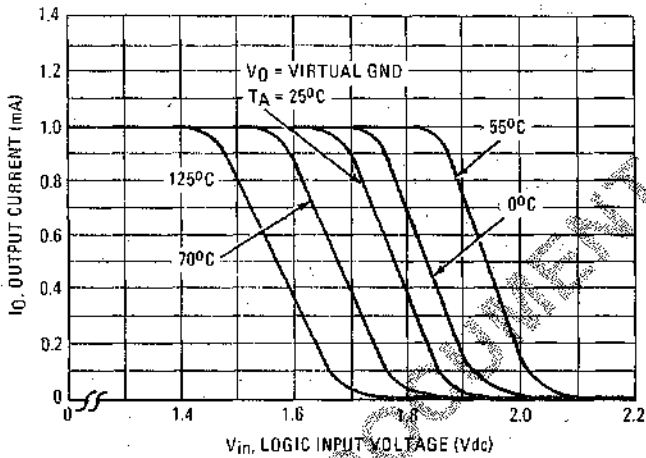
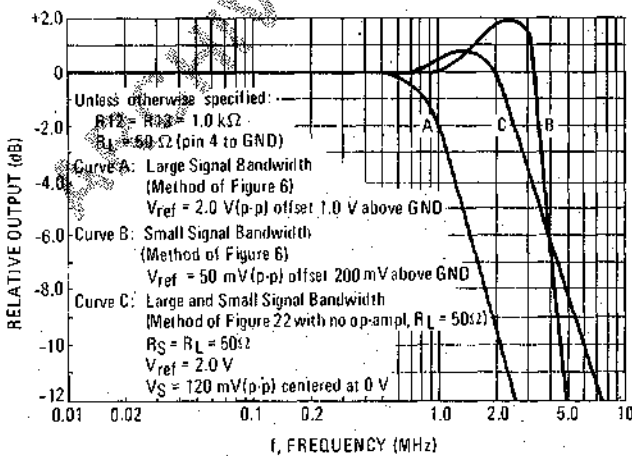


FIGURE 15 — REFERENCE INPUT FREQUENCY RESPONSE



Output Current Range

The output current maximum rating of 4.2 mA may be used only for negative supply voltages below -6.0 volts, due to the increased voltage drop across the 400-ohm resistors in the reference current amplifier.

Output Voltage Compliance

The MC1506L current switches have been designed for high-speed operation and as a result have a restricted output voltage range, as shown in Figures 4 and 5. When a current switch is turned "off", the follower emitter is near ground and a positive voltage on the output terminal can turn "on" the output diode and increase the output current level. When a current switch is turned "on", the negative output voltage range is restricted. The base of the termination circuit Darlington amplifier is one diode voltage below ground; thus a negative voltage below the specified safe level will drive the low current device of the Darlington into saturation, decreasing the output current level.

For example, at +25°C the allowable voltage compliance on Pin 4 to maintain six-bit accuracy is +0.1 to -0.3 Volts. With a full scale output current of 2.0 mA, the maximum resistor value that can be connected from Pin 4 to ground is 150 ohms.

Accuracy

Absolute accuracy is the measure of each output current level with respect to its intended value, and is dependent upon relative accuracy and full scale current drift. Relative accuracy is the measure of each output current level as a fraction of the full scale current. The relative accuracy of the MC1506L is essentially constant with temperature due to the excellent temperature tracking of the monolithic resistor ladder. The reference current may drift with temperature, causing a change in the absolute accuracy of output current.

The best temperature performance is achieved with a -6.0 V supply and a reference voltage of -3.0 volts. These conditions match the voltage across the NPN current source pair in the reference amplifier at the lowest possible voltage, matching and optimizing the output impedance of the pair.

The MC1506L/MC1406L is guaranteed accurate to within  $\pm 1/2$  LSB at +25°C at a full scale output current of 1.969 mA. This corresponds to a reference amplifier output current drive to the ladder of 2.0 mA, with the loss of one LSB = 31  $\mu\text{A}$  that is the ladder remainder shunted to ground. The input current to Pin 12 has a guaranteed current range value of between 1.9 to 2.1 mA, allowing



## GENERAL INFORMATION (continued)

some mismatch in the NPN current source pair. The accuracy test circuit is shown in Figure 10. The 12-bit converter is calibrated for a full scale output current of 1.969 mA. This is an optional step since the MC1506L accuracy is essentially the same between 1.5 to 2.5 mA. Then the MC1506L full scale current is trimmed to the same value with R12 so that a zero value appears at the error amplifier output. The counter is activated and the error band may be displayed on an oscilloscope, detected by comparators, or stored in a peak detector.

Two 6-bit D-to-A converters may not be used to construct a 12-bit accurate D-to-A converter. 12-bit accuracy implies a total error of  $\pm 1/2$  of one part in 4096, or  $\pm 0.012\%$ , which is more accurate than the  $\pm 0.78\%$  specification provided by the MC1506L.

**Multiplying Accuracy**

The MC1506L may be used in the multiplying mode with six-bit accuracy when the reference current is varied over a range of 64:1. The major source of error is the bias current of the termination amplifier. Under "worst case" conditions these six amplifiers can contribute a total of  $6.0 \mu\text{A}$  extra current at the output terminal. If the reference current in the multiplying mode ranges from  $60 \mu\text{A}$  to 4.0 mA, the  $6.0 \mu\text{A}$  contributes an error of 0.1 LSB. This is well within six-bit accuracy.

A monotonic converter is one which supplies an increase in current for each increment in the binary word. Typically, the MC1506L is monotonic for all values of reference current above 0.5 mA. The recommended range for operation with a dc reference current is 0.5 to 4.0 mA.

**Settling Time**

The "worst case" switching condition occurs when all bits are switched "on", which corresponds to a high-to-low transition for all bits. This time is typically 150 ns to within  $\pm 1/2$  LSB, while the turn "off" is typically under 50 ns.

The slowest single switch is the least significant bit, which turns "on" and settles in 50 ns and turns "off" in 30 ns. In applications where the D-to-A converter functions in a positive-going ramp mode, the "worst case" switching condition does not occur, and a settling time of less than 150 ns may be realized.

**Reference Amplifier Drive and Compensation**

The reference amplifier provides a voltage at Pin 12 for converting the reference voltage to a current, and a turn-

around circuit or current mirror for feeding the ladder. The reference amplifier input current, I12, must always flow into Pin 12 regardless of the setup method or reference voltage polarity.

Connections for a positive reference voltage are shown in Figure 6. The reference voltage source supplies the full current I12. Compensation is accomplished by Miller feedback from Pin 14 to Pin 13. This compensation method yields the best slew rate, typically better than  $2.0 \text{ mA}/\mu\text{s}$ , and is independent of the value of R12. R13 must be used to establish the proper impedance for compensation at Pin 13. For bipolar reference signals, as in the multiplying mode, R13 can be tied to a negative voltage corresponding to the minimum input level. Another method is shown in Figure 22.

It is possible to eliminate R13 with only a small sacrifice in accuracy and temperature drift. For instance when high-speed operation is not needed, a capacitor is connected from pin 14 to  $V_{EE}$ . The capacitor value must be increased when R12 is made larger to maintain a proper phase margin. For R12 values of 1.0, 2.5, and 5.0 kilohms, minimum capacitor values are 50, 125, and 250 pF.

Connections for a negative reference voltage are shown in Figure 7. A high input impedance is the advantage of this method, but Miller feedback cannot be used because it feeds the input signal around the PNP directly into the high impedance node, causing slewing problems and high frequency peaking. Compensation involves a capacitor to  $V_{EE}$  on Pin 14, using the values of the previous paragraph. The negative reference voltage must be at least 3.0 V above  $V_{EE}$ . Bipolar input signals may be handled by connecting R12 to a positive reference voltage equal to the peak positive input level at Pin 13.

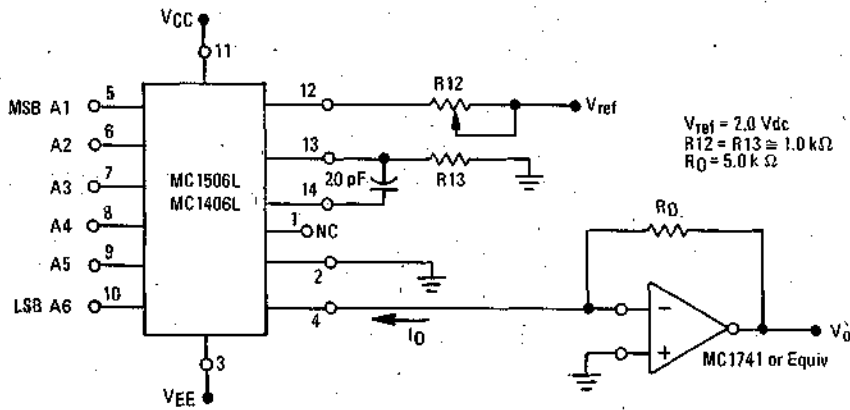
When a dc reference voltage is used, capacitive bypass to ground is recommended. The 5.0 V logic supply is not recommended as a reference voltage. If a well regulated 5.0 V supply which drives logic is to be used as the reference, R12 should be decoupled by connecting it to +5.0 V through another resistor and bypassing the junction of the two resistors with  $0.1 \mu\text{F}$  to ground. For reference voltages greater than 5.0 V, a clamp diode is recommended between Pin 12 and ground.

If Pin 12 is driven by a high impedance such as a transistor current source, none of the above compensation methods apply and the amplifier must be heavily compensated, thus decreasing the overall bandwidth.



APPLICATIONS INFORMATION

FIGURE 16 — OUTPUT CURRENT VOLTAGE CONVERSION



$V_{ref} = 2.0 \text{ Vdc}$   
 $R_{12} = R_{13} \cong 1.0 \text{ k}\Omega$   
 $R_0 = 5.0 \text{ k}\Omega$

Theoretical  $V_0$

$$V_0 = \frac{V_{ref}}{R_{12}} (R_0) \left( \frac{A_1}{2} + \frac{A_2}{4} + \frac{A_3}{8} + \frac{A_4}{16} + \frac{A_5}{32} + \frac{A_6}{64} \right) = K R_0 \left( \frac{A}{2} \right)$$

Adjust  $R_{ref}$  so that  $V_0$  with all digital inputs at low level is equal to 9.844 volts.

$$V_0 = \frac{2 \text{ V}}{1 \text{ K}} (5 \text{ K}) \left( \frac{1}{2} + \frac{1}{4} + \frac{1}{8} + \frac{1}{16} + \frac{1}{32} + \frac{1}{64} \right) = 10 \text{ V} \left( \frac{63}{64} \right) = 9.844 \text{ V}$$

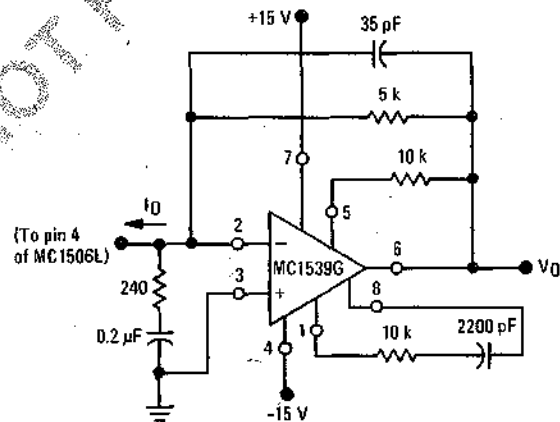
Voltage outputs of a larger magnitude are obtainable with this circuit which uses an external operational amplifier as a current to voltage converter. This configuration automatically keeps the output of the MC1506L at ground potential and the operational amplifier can generate a positive voltage limited only by its positive supply voltage. Frequency response and settling time are primarily determined by the characteristics of the operational amplifier. In addition, the operational amplifier must be compensated for unity gain, and in some cases overcompensation may be desirable.

Note that this configuration results in a positive output voltage only, the magnitude of which is dependent on the digital input.

The following circuit shows how the MLM301AG can be used in a feedforward mode resulting in a full scale settling time on the order of 2.0  $\mu$ s.

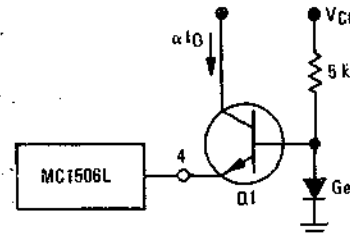
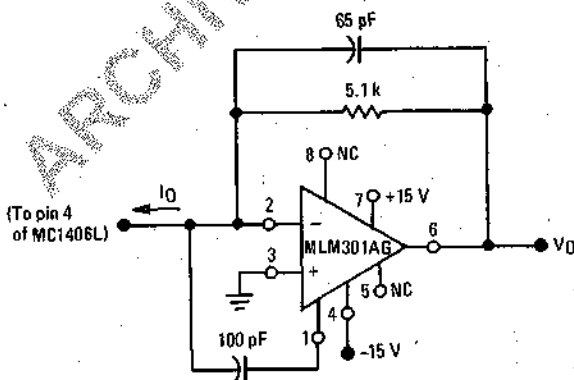
An alternative method is to use the MC1539G and input compensation. Response of this circuit is also on the order of 2.0  $\mu$ s. See Motorola Application Note AN-459 for more details on this concept.

FIGURE 18



The positive voltage range may be extended by cascading the output with a high beta common base transistor, Q1, as shown.

FIGURE 17



The output voltage range for this circuit is 0 volts to  $BVC_{BO}$  of the transistor. Variations in beta must be considered for wide temperature range applications. An inverted output waveform may be obtained by using a load resistor from a positive reference voltage to the collector of the transistor. Also, high-speed operation is possible with a large output voltage swing.





APPLICATIONS INFORMATION (continued)

Combined Output Amplifier and Voltage Reference

For many of its applications the MC1506L requires a reference voltage and an operational amplifier. Normally the operational amplifier is used as a current to voltage converter and its output need only go positive. With the popular MC1723G voltage regulator both of these functions are provided in a single package with the added bonus of up to 150 mA of output current, see Figure 19. Instead of powering the MC1723G from a single positive voltage supply, it uses a negative bias as well. Although the reference voltage of the MC1723G is then developed with respect to that negative voltage it appears as a common-mode signal to the reference amplifier in the D-to-A converter. This allows use of its output amplifier as a classic current-to-voltage converter with the non-inverting input grounded.

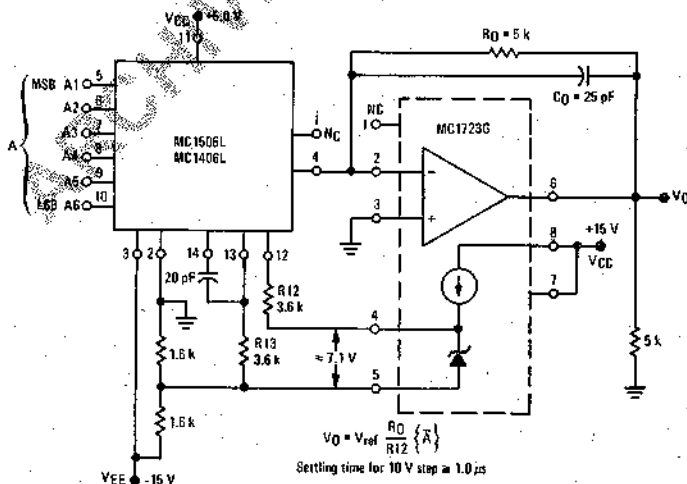
Since ±15 V and +5.0 V are normally available in a combination digital-to-analog system, only the -5.0 V need be developed. A resistor divider is sufficiently accurate since the allowable range on pin 5 is from -2.0 to -8.0 volts. The 5.0 kilohm pulldown resistor on the amplifier output is necessary for fast negative transitions.

Full scale output may be increased to as much as 32 volts by increasing  $R_O$  and raising the +15 V supply voltage to 35 V maximum. The resistor divider should be altered to comply with the maximum limit of 40 volts across the MC1723G.  $C_O$  may be decreased to maintain the same  $R_O C_O$  product if maximum speed is desired.

Programmable Power Supply

The circuit of Figure 19 can be used as a digitally programmed power supply by the addition of thumbwheel switches and a BCD-to-binary converter. The output voltage can be scaled in several ways, including 0 to +6.3 volts in 0.1-volt increments, ±0.05 volt, or 0 to 31.5 volts in 0.5-volt increments, ±0.25 volt.

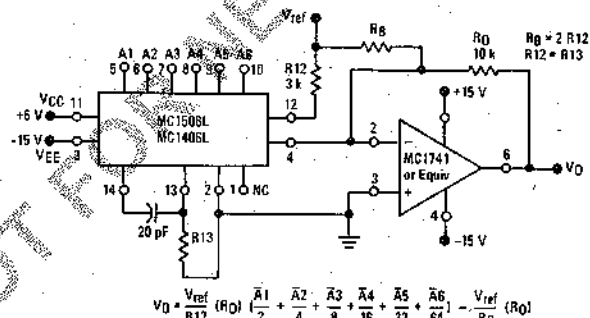
FIGURE 19 — COMBINED OUTPUT AMPLIFIER and VOLTAGE REFERENCE CIRCUIT



Bipolar or Negative Output Voltage

The circuit of Figure 20 is a variation from the standard voltage output circuit and will produce bipolar output signals. A positive current may be sourced into the summing node to offset the output voltage in the negative direction. For example, if approximately 1.0 mA is used a bipolar output signal results which may be described as a 6-bit "1's" complement offset binary.  $V_{ref}$  may be used as this auxiliary reference. Note that  $R_O$  has been doubled to 10 kilohms because of the anticipated 20 V (p-p) output range.

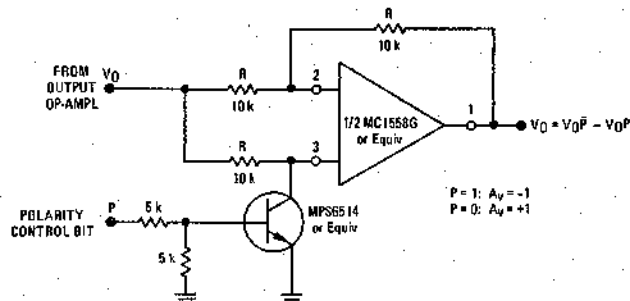
FIGURE 20 — BIPOLAR OR NEGATIVE OUTPUT VOLTAGE CIRCUIT



Polarity Switching Circuit, 6-Bit Magnitude Plus Sign D-to-A Converter

Bipolar outputs may also be obtained by using a polarity switching circuit. The circuit of Figure 21, gives 6-bits magnitude plus a sign bit. In this configuration the operational amplifier is switched between a gain of +1.0 and -1.0. Although another operational amplifier is required, no more space is taken when a dual operational amplifier such as the MC1558G is used. The transistor should be selected for a very low saturation voltage and resistance.

FIGURE 21 — POLARITY SWITCHING CIRCUIT (6-Bit Magnitude Plus Sign D-to-A Converter)

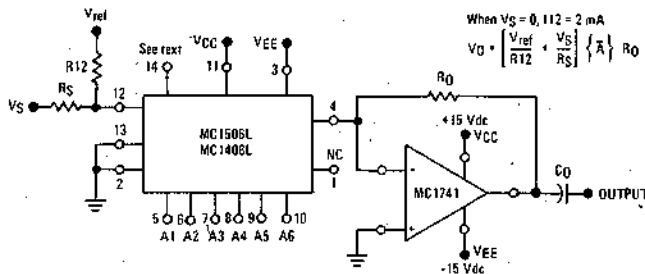


APPLICATIONS INFORMATION (continued)

Programmable Gain Amplifier or Digital Attenuator

When used in the multiplying mode the MC1506L can be applied as a digital attenuator. See Figure 22. One advantage of this technique is that if  $R_S = 50$  ohms, no compensation capacitor is needed and a wide large signal bandwidth is achieved. The small and large signal bandwidths are now identical and are shown in Figure 15.

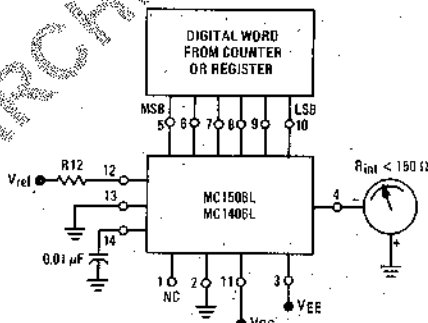
FIGURE 22 – PROGRAMMABLE GAIN AMPLIFIER OR DIGITAL ATTENUATOR CIRCUIT



Panel Meter Readout

The MC1506L can be used to read out the status of BCD or binary registers or counters in a digital control system. The current output can be used to drive directly an analog panel meter. External meter shunts may be necessary if a meter of less than 2.0 mA full scale is used. Full scale calibration can be done by adjusting R12 or  $V_{ref}$ .

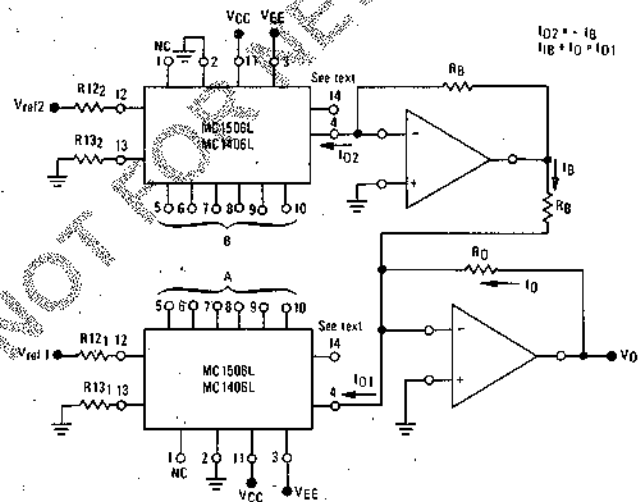
FIGURE 23 – PANEL METER READOUT CIRCUIT



The best frequency response is obtained by not allowing  $I_{12}$  to reach zero.  $R_S$  can be set for a  $\pm 1.0$  mA variation in relation to  $I_{12}$ .  $I_{12}$  can never be negative.

The output current is always unipolar. The quiescent dc output current level changes with the digital word that makes ac coupling necessary.

FIGURE 24 – DC COUPLED DIGITAL ATTENUATOR and DIGITAL SUBTRACTION



$$I_0 = I_{01} - I_{02} = \frac{V_{ref1}}{R_{121}} \{A\} - \frac{V_{ref2}}{R_{122}} \{B\}$$

Digital Subtraction:

$$\text{let } \frac{V_{ref1}}{R_{121}} = \frac{V_{ref2}}{R_{122}}$$

$$V_0 = \frac{V_{ref1}}{R_{121}} R_0 \{A\} - \{B\}$$

Programmable Amplifier:

Connect digital inputs to A = B

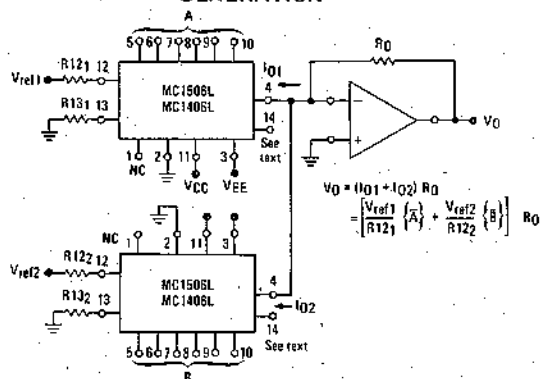
$$V_0 = \{A\} \left[ \frac{V_{ref1}}{R_{121}} - \frac{V_{ref2}}{R_{122}} \right]$$

This digital subtraction application is useful for indicating when one digital word is approaching another in value. More information is available than with a digital comparator.

Bipolar inputs can be accepted by using any of the previously described methods, or applied differentially to  $R_{121}$  and  $R_{122}$  or  $R_{131}$  and  $R_{132}$ .  $V_0$  will be a bipolar signal defined by the above equation. Note that the circuit shown accepts bipolar differential signals but does not have a negative common-mode range. A very useful method is to connect  $R_{121}$  and  $R_{122}$  to a positive reference higher than the most positive input, and drive  $R_{131}$  and  $R_{132}$ . This yields high input impedance, bipolar differential and common-mode range. The compensation depends on the input method used, as shown in previous sections.

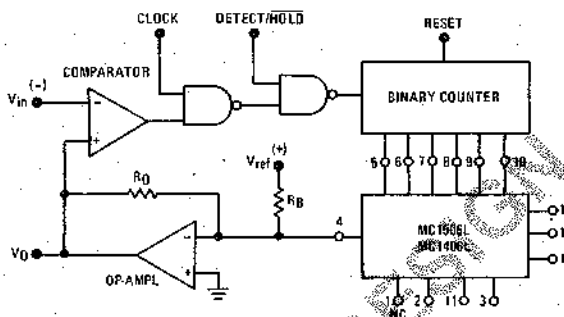


FIGURE 25 – DIGITAL SUMMING and CHARACTER GENERATION



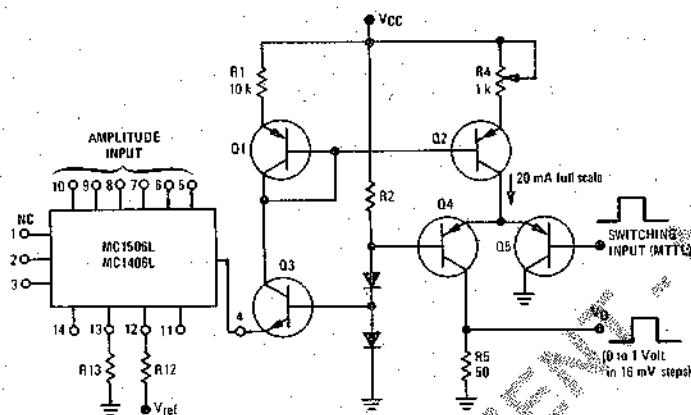
In a character generation system one MC1506L circuit uses a fixed reference voltage and its digital input defines the starting point for a stroke. The second converter circuit has a ramp input for the reference and its digital input defines the slope of the stroke. Note that this approach does not result in a 12-bit D-to-A converter (see Accuracy Section).

FIGURE 26 – PEAK DETECTING SAMPLE and HOLD (Features infinite hold time and optional digital output.)



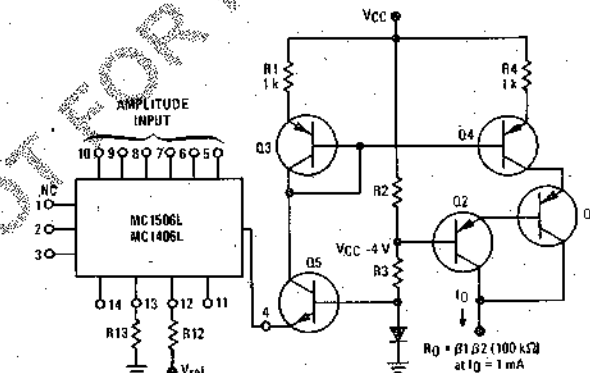
Positive peaks may be detected by inserting a hex inverter between the counter and MC1506L, reversing the comparator inputs, and connecting the output amplifier for unipolar operation.

FIGURE 27 – PROGRAMMABLE PULSE GENERATOR



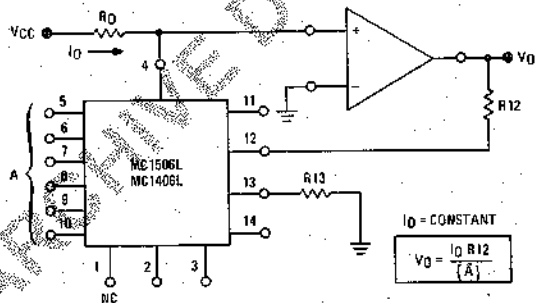
Fast rise and fall times require the use of high speed switching transistors for the differential pair, Q4 and Q5. Linear ramps and sine waves may be generated by the appropriate reference input.

FIGURE 28 – PROGRAMMABLE CONSTANT CURRENT SOURCE



Current pulses, ramps, staircases, and sine waves may be generated by the appropriate digital and reference inputs. This circuit is especially useful in curve tracer applications.

FIGURE 29 – ANALOG DIVISION BY DIGITAL WORD



This circuit yields the inverse of a digital word scaled by a constant. For minimum error over the range of operation, I0 can be set at 62 μA so that I12 will have a maximum value of 3.938 mA for a digital bit input configuration of 11110.

Compensation is necessary for loop stability and depends on the type of operational amplifier used. If a standard 1.0 MHz operational amplifier is employed, it should be overcompensated when possible. If this cannot be done, the reference amplifier can furnish the dominant pole with extra Miller feedback from pin 14 to 13. If the MC1723 or another wideband amplifier is used, the reference amplifier should always be overcompensated.

FIGURE 30 – ANALOG QUOTIENT OF TWO DIGITAL WORDS

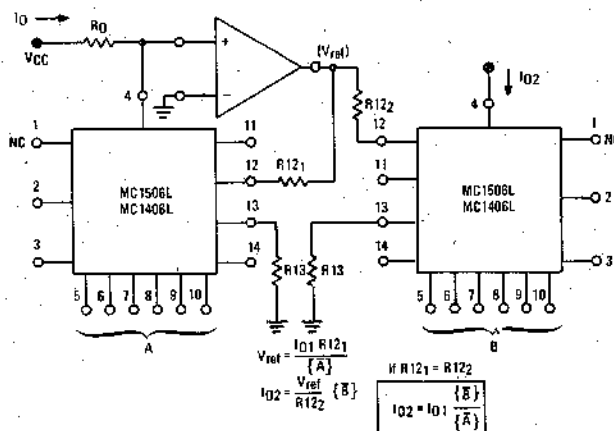
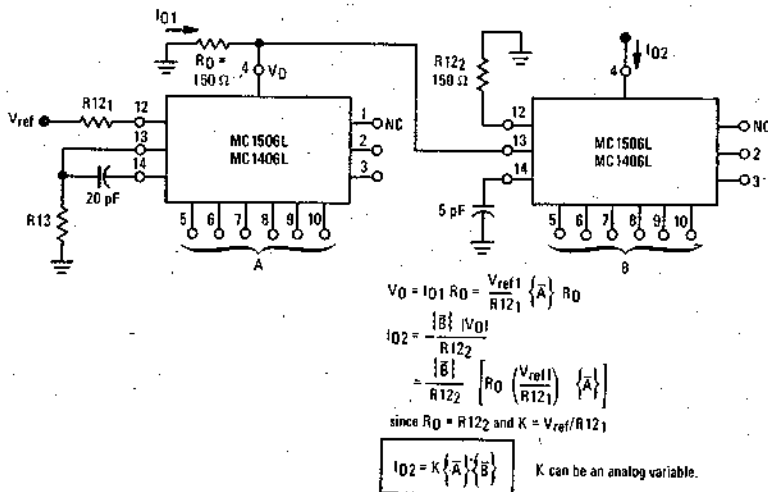


FIGURE 31 - ANALOG PRODUCT OF TWO DIGITAL WORDS  
(High-Speed Operation)



Two Digit BCD Conversion

MC1506L parts which meet the specification for 7-bit accuracy can be used for the most significant word when building a two digit BCD D-to-A or A-to-D converter. If both outputs feed the virtual ground of an operational amplifier, 10:1 current scaling can be achieved with a resistive current divider. If current output is desired, the units may be operated at full scale current levels of 4.0 mA and 0.4 mA with the outputs connected to sum the currents. The error of the D-to-A converter handling the least significant bits will be scaled down by a factor of ten.

Weight = 1.954 grams

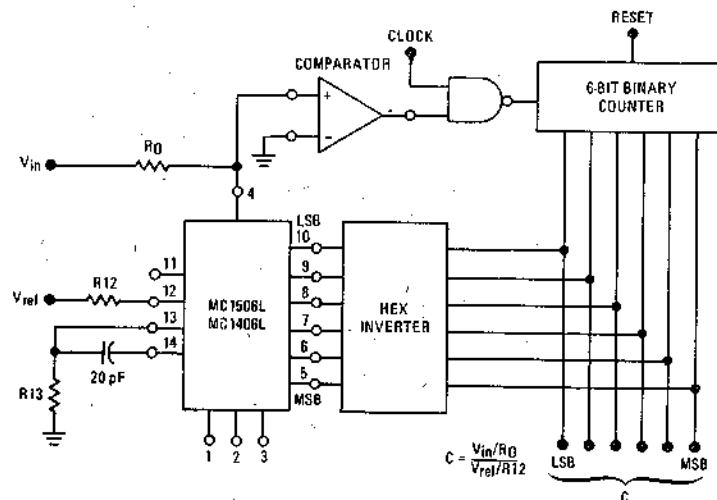
DIMENSION "L" TO CENTER OF LEADS WHEN FORMED PARALLEL.

All JEDEC dimensions and notes apply.

DIM	MILLIMETERS		INCHES	
	MIN	MAX	MIN	MAX
A	16.8	19.9	0.660	0.785
B	5.59	7.11	0.220	0.280
C	-	5.08	-	0.200
D	0.381	0.584	0.015	0.023
F	0.77	1.77	0.030	0.070
G	2.54 BSC	-	0.100 BSC	-
J	0.203	0.381	0.008	0.015
K	2.54	-	0.100	-
L	7.62 BSC	-	0.300 BSC	-
M	-	15°	-	15°
N	0.51	0.76	0.020	0.030
P	-	8.25	-	0.325

FIGURE 32 - DIGITAL QUOTIENT OF TWO ANALOG VARIABLES  
or ANALOG-TO-DIGITAL CONVERSION

The circuit shown is a simple counter-ramp converter. An UP/DOWN counter and dual threshold comparator can be used to provide faster operation and continuous conversion.



Circuit diagrams utilizing Motorola products are included as a means of illustrating typical semiconductor applications; consequently, complete information sufficient for construction purposes is not necessarily given. The information has been carefully checked and

is believed to be entirely reliable. However, no responsibility is assumed for inaccuracies. Furthermore, such information does not convey to the purchaser of the semiconductor devices described any license under the patent rights of Motorola Inc. or others.

