

PROGRAMMABLE COMMUNICATION INTERFACE

- **Synchronous and Asynchronous Operation**
 - **Synchronous:**
 - 5-8 Bit Characters
 - Internal or External Character Synchronization
 - Automatic Sync Insertion
 - **Asynchronous:**
 - 5-8 Bit Characters
 - Clock Rate — 1, 16 or 64 Times Baud Rate
 - Break Character Generation
 - 1, 1½, or 2 Stop Bits
 - False Start Bit Detection
- **Baud Rate — DC to 56k Baud (Sync Mode)
DC to 9.6k Baud (Async Mode)**
- **Full Duplex, Double Buffered, Transmitter and Receiver**
- **Error Detection — Parity, Overrun, and Framing**
- **Fully Compatible with 8080 CPU**
- **28-Pin DIP Package**
- **All Inputs and Outputs Are TTL Compatible**
- **Single 5 Volt Supply**
- **Single TTL Clock**

The 8251 is a Universal Synchronous/Asynchronous Receiver / Transmitter (USART) Chip designed for data communications in microcomputer systems. The USART is used as a peripheral device and is programmed by the CPU to operate using virtually any serial data transmission technique presently in use (including IBM Bi-Sync). The USART accepts data characters from the CPU in parallel format and then converts them into a continuous serial data stream for transmission. Simultaneously it can receive serial data streams and convert them into parallel data characters for the CPU. The USART will signal the CPU whenever it can accept a new character for transmission or whenever it has received a character for the CPU. The CPU can read the complete status of the USART at any time. These include data transmission errors and control signals such as SYNDET, TxEMPT. The chip is constructed using N-channel silicon gate technology.

PIN CONFIGURATION

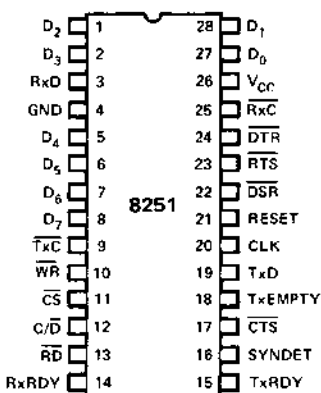

Pin Name	Pin Function
D ₇ -D ₀	Data Bus (8 bits)
C/D	Control or Data is to be Written or Read
RD	Read Data Command
WR	Write Data or Control Command
CS	Chip Enable
CLK	Clock Pulse (TTL)
RESET	Reset
TxC	Transmitter Clock
TxD	Transmitter Data
RxC	Receiver Clock
RxD	Receiver Data
RxRDY	Receiver Ready (has character for 8080)
TxRDY	Transmitter Ready (ready for char. from 8080)

Pin Name	Pin Function
DSR	Data Set Ready
DTR	Data Terminal Ready
SYNDET	Sync Detect
RTS	Request to Send Data
CTS	Clear to Send Data
TxE	Transmitter Empty
V _{CC}	+5 Volt Supply
GND	Ground

BLOCK DIAGRAM

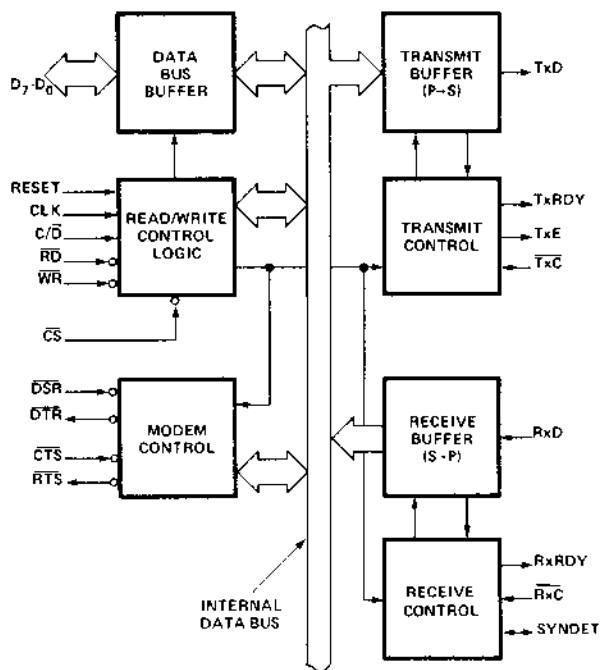

8251 BASIC FUNCTIONAL DESCRIPTION

General

The 8251 is a Universal Synchronous/Asynchronous Receiver/Transmitter designed specifically for the 8080 Micro-computer System. Like other I/O devices in the 8080 Micro-computer System its functional configuration is programmed by the systems software for maximum flexibility. The 8251 can support virtually any serial data technique currently in use (including IBM "bi-sync").

In a communication environment an interface device must convert parallel format system data into serial format for transmission and convert incoming serial format data into parallel system data for reception. The interface device must also delete or insert bits or characters that are functionally unique to the communication technique. In essence, the interface should appear "transparent" to the CPU, a simple input or output of byte-oriented system data.

Data Bus Buffer

This 3-state, bi-directional, 8-bit buffer is used to interface the 8251 to the 8080 system Data Bus. Data is transmitted or received by the buffer upon execution of INput or OUTput instructions of the 8080 CPU. Control words, Command words and Status information are also transferred through the Data Bus Buffer.

Read/Write Control Logic

This functional block accepts inputs from the 8080 Control bus and generates control signals for overall device operation. It contains the Control Word Register and Command Word Register that store the various control formats for device functional definition.

RESET (Reset)

A "high" on this input forces the 8251 into an "Idle" mode. The device will remain at "Idle" until a new set of control words is written into the 8251 to program its functional definition.

CLK (Clock)

The CLK input is used to generate internal device timing and is normally connected to the Phase 2 (TTL) output of the 8224 Clock Generator. No external inputs or outputs are referenced to CLK but the frequency of CLK must be greater than 30 times the Receiver or Transmitter clock inputs for synchronous mode (4.5 times for asynchronous mode).

\overline{WR} (Write)

A "low" on this input informs the 8251 that the CPU is outputting data or control words, in essence, the CPU is writing out to the 8251.

\overline{RD} (Read)

A "low" on this input informs the 8251 that the CPU is inputting data or status information, in essence, the CPU is reading from the 8251.

C/\overline{D} (Control/Data)

This input, in conjunction with the \overline{WR} and \overline{RD} inputs informs the 8251 that the word on the Data Bus is either a data character, control word or status information.
1 = CONTROL 0 = DATA

\overline{CS} (Chip Select)

A "low" on this input enables the 8251. No reading or writing will occur unless the device is selected.

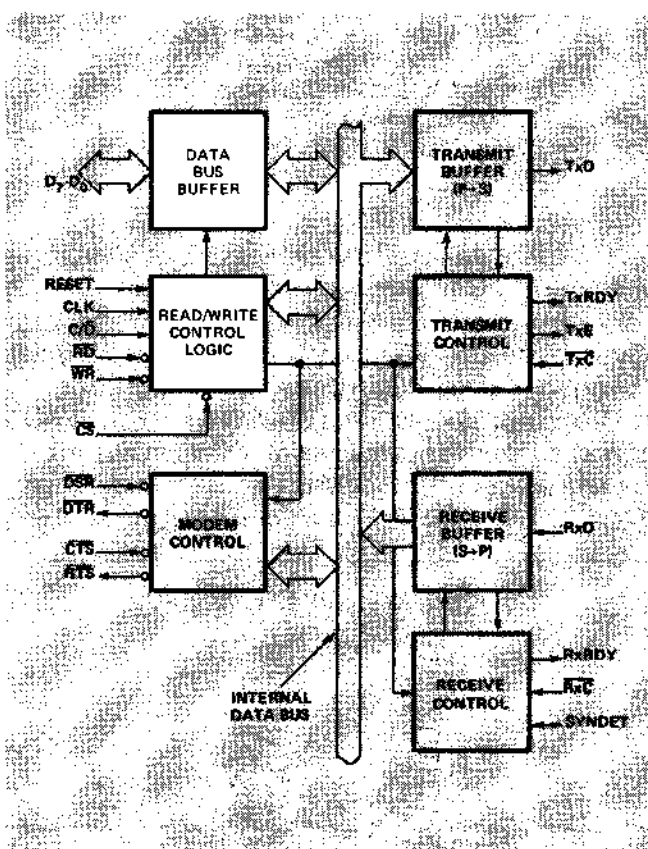

C/\overline{D}	\overline{RD}	\overline{WR}	\overline{CS}	
0	0	1	0	8251 \Rightarrow DATA BUS
0	1	0	0	DATA BUS \Rightarrow 8251
1	0	1	0	STATUS \Rightarrow DATA BUS
1	1	0	0	DATA BUS \Rightarrow CONTROL
X	X	X	1	DATA BUS \Rightarrow 3-STATE

Modem Control

The 8251 has a set of control inputs and outputs that can be used to simplify the interface to almost any Modem. The modem control signals are general purpose in nature and can be used for functions other than Modem control, if necessary.

\overline{DSR} (Data Set Ready)

The \overline{DSR} input signal is general purpose in nature. Its condition can be tested by the CPU using a Status Read operation. The \overline{DSR} input is normally used to test Modem conditions such as Data Set Ready.

\overline{DTR} (Data Terminal Ready)

The \overline{DTR} output signal is general purpose in nature. It can be set "low" by programming the appropriate bit in the Command Instruction word. The \overline{DTR} output signal is normally used for Modem control such as Data Terminal Ready or Rate Select.

\overline{RTS} (Request to Send)

The \overline{RTS} output signal is general purpose in nature. It can be set "low" by programming the appropriate bit in the Command Instruction word. The \overline{RTS} output signal is normally used for Modem control such as Request to Send.

\overline{CTS} (Clear to Send)

A "low" on this input enables the 8251 to transmit data (serial) if the Tx EN bit in the Command byte is set to a "one."

Transmitter Buffer

The Transmitter Buffer accepts parallel data from the Data Bus Buffer, converts it to a serial bit stream, inserts the appropriate characters or bits (based on the communication technique) and outputs a composite serial stream of data on the TxD output pin.

Transmitter Control

The Transmitter Control manages all activities associated with the transmission of serial data. It accepts and issues signals both externally and internally to accomplish this function.

TxRDY (Transmitter Ready)

This output signals the CPU that the transmitter is ready to accept a data character. It can be used as an interrupt to the system or for the Polled operation the CPU can check TxRDY using a status read operation. TxRDY is automatically reset when a character is loaded from the CPU.

TxE (Transmitter Empty)

When the 8251 has no characters to transmit, the TxE output will go "high". It resets automatically upon receiving a character from the CPU. TxE can be used to indicate the end of a transmission mode, so that the CPU "knows" when to "turn the line around" in the half-duplexed operational mode.

In SYNChronous mode, a "high" on this output indicates that a character has not been loaded and the SYNC character or characters are about to be transmitted automatically as "fillers".

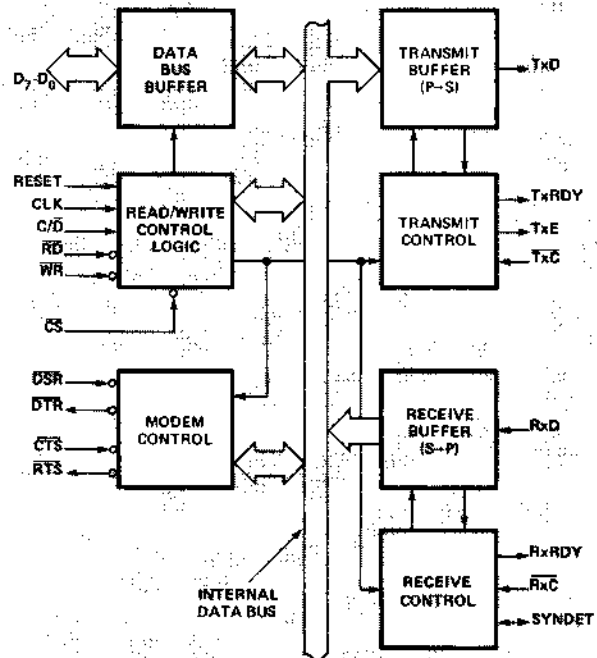

$\overline{Tx̄C}$ (Transmitter Clock)

The Transmitter Clock controls the rate at which the character is to be transmitted. In the Synchronous transmission mode, the frequency of $\overline{Tx̄C}$ is equal to the actual Baud Rate (1X). In Asynchronous transmission mode, the frequency of $\overline{Tx̄C}$ is a multiple of the actual Baud Rate. A portion of the mode instruction selects the value of the multiplier; it can be 1x, 16x or 64x the Baud Rate.

For Example:

If Baud Rate equals 110 Baud,
 $\overline{Tx̄C}$ equals 110 Hz (1x)
 $\overline{Tx̄C}$ equals 1.76 kHz (16x)
 $\overline{Tx̄C}$ equals 7.04 kHz (64x).
 If Baud Rate equals 9600 Baud,
 $\overline{Tx̄C}$ equals 614.4 kHz (64x).

The falling edge of $\overline{Tx̄C}$ shifts the serial data out of the 8251.

Receiver Buffer

The Receiver accepts serial data, converts this serial input to parallel format, checks for bits or characters that are unique to the communication technique and sends an "assembled" character to the CPU. Serial data is input to the RxD pin.

Receiver Control

This functional block manages all receiver-related activities.

RxDY (Receiver Ready)

This output indicates that the 8251 contains a character that is ready to be input to the CPU. RxDY can be connected to the interrupt structure of the CPU or for Polled operation the CPU can check the condition of RxDY using a status read operation. RxDY is automatically reset when the character is read by the CPU.

RxC (Receiver Clock)

The Receiver Clock controls the rate at which the character is to be received. In Synchronous Mode, the frequency of RxC is equal to the actual Baud Rate (1x). In Asynchronous Mode, the frequency of RxC is a multiple of the actual Baud Rate. A portion of the mode instruction selects the value of the multiplier; it can be 1x, 16x or 64x the Baud Rate.

For Example: If Baud Rate equals 300 Baud,
 RxC equals 300 Hz (1x)
 RxC equals 4800 Hz (16x)
 RxC equals 19.2 kHz (64x).
 If Baud Rate equals 2400 Baud,
 RxC equals 2400 Hz (1x)
 RxC equals 38.4 kHz (16x)
 RxC equals 153.6 kHz (64x).

Data is sampled into the 8251 on the rising edge of RxC.

NOTE: In most communications systems, the 8251 will be handling both the transmission and reception operations of a single link. Consequently, the Receive and Transmit Baud Rates will be the same. Both TxC and RxC will require identical frequencies for this operation and can be tied together and connected to a single frequency source (Baud Rate Generator) to simplify the interface.

SYNDET (SYNC Detect)

This pin is used in SYNCHRONOUS Mode only. It is used as either input or output, programmable through the Control Word. It is reset to "low" upon RESET. When used as an output (internal Sync mode), the SYNDET pin will go "high" to indicate that the 8251 has located the SYNC character in the Receive mode. If the 8251 is programmed to use double Sync characters (bi-sync), then SYNDET will go "high" in the middle of the last bit of the second Sync character. SYNDET is automatically reset upon a Status Read operation.

When used as an input, (external SYNC detect mode), a positive going signal will cause the 8251 to start assembling data characters on the falling edge of the next RxC. Once in SYNC, the "high" input signal can be removed. The duration of the high signal should be at least equal to the period of RxC.

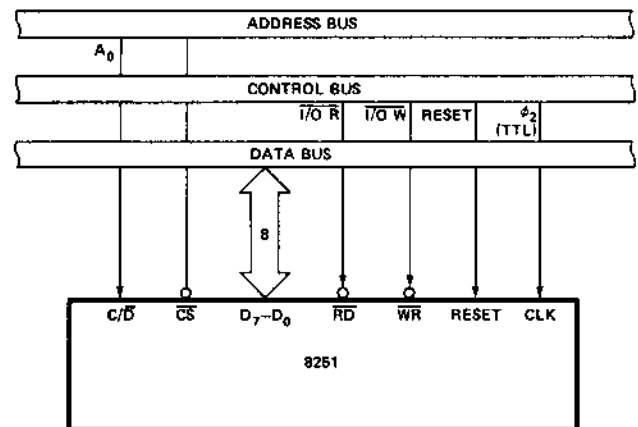
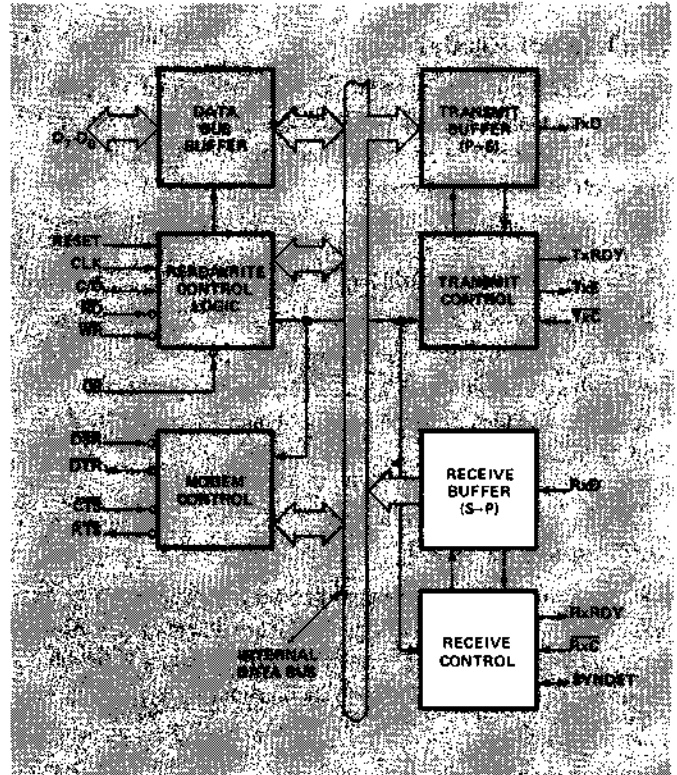

8251 Interface to 8080 Standard System Bus

DETAILED OPERATION DESCRIPTION

General

The complete functional definition of the 8251 is programmed by the systems software. A set of control words must be sent out by the CPU to initialize the 8251 to support the desired communications format. These control words will program the: BAUD RATE, CHARACTER LENGTH, NUMBER OF STOP BITS, SYNCHRONOUS or ASYNCHRONOUS OPERATION, EVEN/ODD PARITY etc. In the Synchronous Mode, options are also provided to select either internal or external character synchronization.

Once programmed, the 8251 is ready to perform its communication functions. The TxRDY output is raised "high" to signal the CPU that the 8251 is ready to receive a character. This output (TxRDY) is reset automatically when the CPU writes a character into the 8251. On the other hand, the 8251 receives serial data from the MODEM or I/O device, upon receiving an entire character the RxRDY output is raised "high" to signal the CPU that the 8251 has a complete character ready for the CPU to fetch. RxRDY is reset automatically upon the CPU read operation.

The 8251 cannot begin transmission until the TxEN (Transmitter Enable) bit is set in the Command Instruction and it has received a Clear To Send (CTS) input. The TxD output will be held in the marking state upon Reset.

Programming the 8251

Prior to starting data transmission or reception, the 8251 must be loaded with a set of control words generated by the CPU. These control signals define the complete functional definition of the 8251 and must immediately follow a Reset operation (internal or external).

The control words are split into two formats:

1. Mode Instruction
2. Command Instruction

Mode Instruction

This format defines the general operational characteristics of the 8251. It must follow a Reset operation (internal or external). Once the Mode instruction has been written into the 8251 by the CPU, SYNC characters or Command instructions may be inserted.

Command Instruction

This format defines a status word that is used to control the actual operation of the 8251.

Both the Mode and Command instructions must conform to a specified sequence for proper device operation. The Mode Instruction must be inserted immediately following a Reset operation, prior to using the 8251 for data communication.

All control words written into the 8251 after the Mode Instruction will load the Command Instruction. Command Instructions can be written into the 8251 at any time in the data block during the operation of the 8251. To return to the Mode Instruction format a bit in the Command Instruction word can be set to initiate an internal Reset operation which automatically places the 8251 back into the Mode Instruction format. Command Instructions must follow the Mode Instructions or Sync characters.

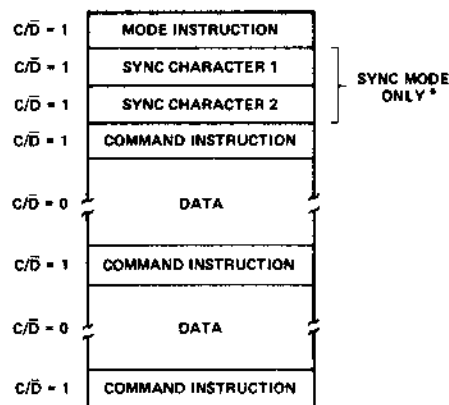

*The second SYNC character is skipped if MODE instruction has programmed the 8251 to single character Internal SYNC Mode. Both SYNC characters are skipped if MODE instruction has programmed the 8251 to ASYNC mode.

Typical Data Block

Mode Instruction Definition

The 8251 can be used for either Asynchronous or Synchronous data communication. To understand how the Mode Instruction defines the functional operation of the 8251 the designer can best view the device as two separate components sharing the same package. One Asynchronous the other Synchronous. The format definition can be changed "on the fly" but for explanation purposes the two formats will be isolated.

Asynchronous Mode (Transmission)

Whenever a data character is sent by the CPU the 8251 automatically adds a Start bit (low level) and the programmed number of Stop bits to each character. Also, an even or odd Parity bit is inserted prior to the Stop bit(s), as defined by the Mode Instruction. The character is then transmitted as a serial data stream on the TxD output. The serial data is shifted out on the falling edge of $\overline{\text{TxC}}$ at a rate equal to 1, 1/16, or 1/64 that of the $\overline{\text{TxC}}$, as defined by the Mode Instruction. BREAK characters can be continuously sent to the TxD if commanded to do so.

When no data characters have loaded into the 8251 the TxD output remains "high" (marking) unless a Break (continuously low) has been programmed.

Asynchronous Mode (Receive)

The RxD line is normally high. A falling edge on this line triggers the beginning of a START bit. The validity of this START bit is checked by again strobing this bit at its nominal center. If a low is detected again, it is a valid START bit, and the bit counter will start counting. The bit counter locates the center of the data bits, the parity bit (if it exists) and the stop bits. If parity error occurs, the parity error flag is set. Data and parity bits are sampled on the RxD pin with the rising edge of $\overline{\text{RxC}}$. If a low level is detected as the STOP bit, the Framing Error flag will be set. The STOP bit signals the end of a character. This character is then loaded into the parallel I/O buffer of the 8251. The $\overline{\text{RxDY}}$ pin is raised to signal the CPU that a character is ready to be fetched. If a previous character has not been fetched by the CPU, the present character replaces it in the I/O buffer, and the $\overline{\text{OVRUN}}$ flag is raised (thus the previous character is lost). All of the error flags can be reset by a command instruction. The occurrence of any of these errors will not stop the operation of the 8251.

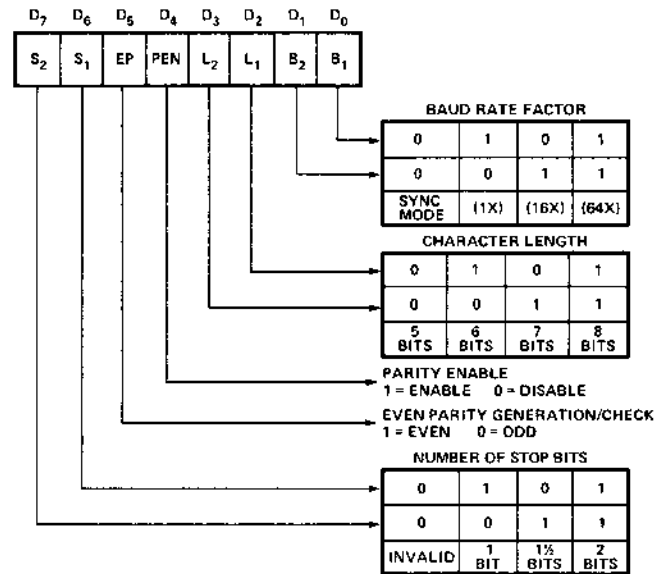

Mode Instruction Format, Asynchronous Mode

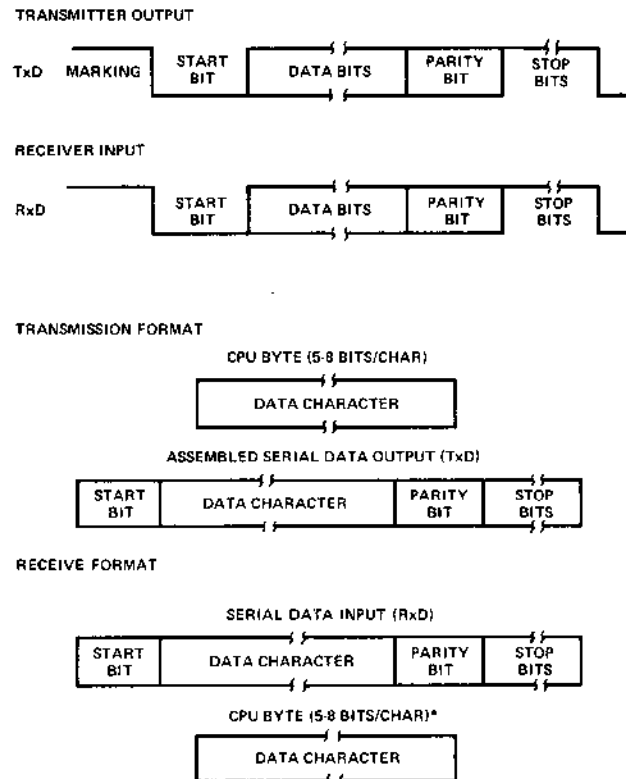

*NOTE: IF CHARACTER LENGTH IS DEFINED AS 5, 6 OR 7 BITS THE UNUSED BITS ARE SET TO "ZERO".

Asynchronous Mode

Synchronous Mode (Transmission)

The TxD output is continuously high until the CPU sends its first character to the 8251 which usually is a SYNC character. When the \overline{CTS} line goes low, the first character is serially transmitted out. All characters are shifted out on the falling edge of \overline{TxC} . Data is shifted out at the same rate as the \overline{TxC} .

Once transmission has started, the data stream at TxD output must continue at the \overline{TxC} rate. If the CPU does not provide the 8251 with a character before the 8251 becomes empty, the SYNC characters (or character if in single SYNC word mode) will be automatically inserted in the TxD data stream. In this case, the TxEMPTY pin is raised high to signal that the 8251 is empty and SYNC characters are being sent out. The TxEMPTY pin is internally reset by the next character being written into the 8251.

Synchronous Mode (Receive)

In this mode, character synchronization can be internally or externally achieved. If the internal SYNC mode has been programmed, the receiver starts in a HUNT mode. Data on the RxD pin is then sampled in on the rising edge of \overline{RxC} . The content of the Rx buffer is continuously compared with the first SYNC character until a match occurs. If the 8251 has been programmed for two SYNC characters, the subsequent received character is also compared; when both SYNC characters have been detected, the USART ends the HUNT mode and is in character synchronization. The SYNDET pin is then set high, and is reset automatically by a STATUS READ.

In the external SYNC mode, synchronization is achieved by applying a high level on the SYNDET pin. The high level can be removed after one \overline{RxC} cycle.

Parity error and overrun error are both checked in the same way as in the Asynchronous Rx mode.

The CPU can command the receiver to enter the HUNT mode if synchronization is lost.

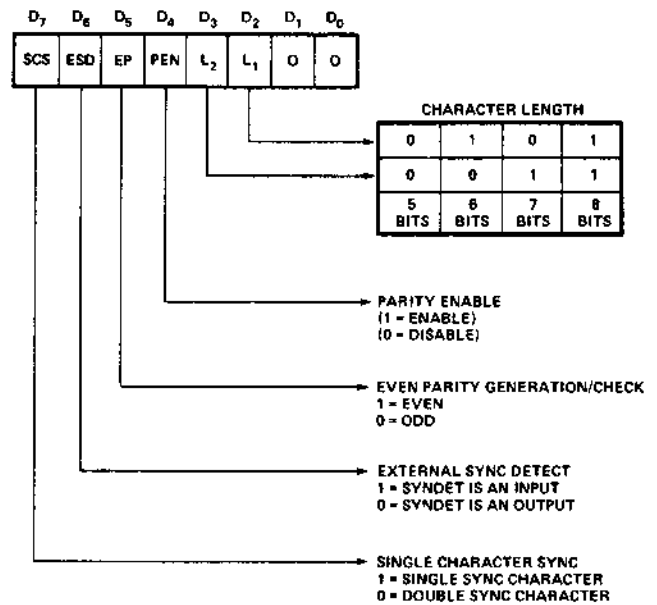

Mode Instruction Format, Synchronous Mode

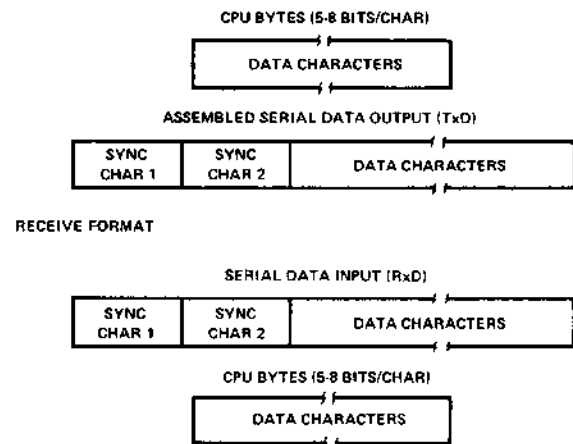

Synchronous Mode, Transmission Format

COMMAND INSTRUCTION DEFINITION

Once the functional definition of the 8251 has been programmed by the Mode Instruction and the Sync Characters are loaded (if in Sync Mode) then the device is ready to be used for data communication. The Command Instruction controls the actual operation of the selected format. Functions such as: Enable Transmit/Receive, Error Reset and Modem Controls are provided by the Command Instruction.

Once the Mode Instruction has been written into the 8251 and Sync characters inserted, if necessary, then all further "control writes" ($C/\bar{D} = 1$) will load the Command Instruction. A Reset operation (internal or external) will return the 8251 to the Mode Instruction Format.

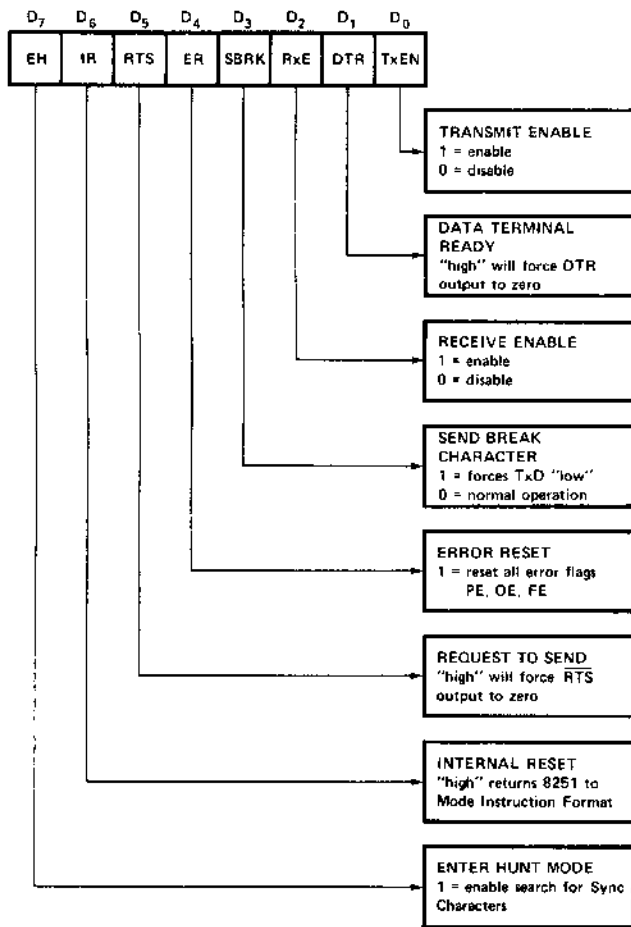

Command Instruction Format

STATUS READ DEFINITION

In data communication systems it is often necessary to examine the "status" of the active device to ascertain if errors have occurred or other conditions that require the processor's attention. The 8251 has facilities that allow the programmer to "read" the status of the device at any time during the functional operation.

A normal "read" command is issued by the CPU with the C/D input at one to accomplish this function.

Some of the bits in the Status Read Format have identical meanings to external output pins so that the 8251 can be used in a completely Polled environment or in an interrupt driven environment.

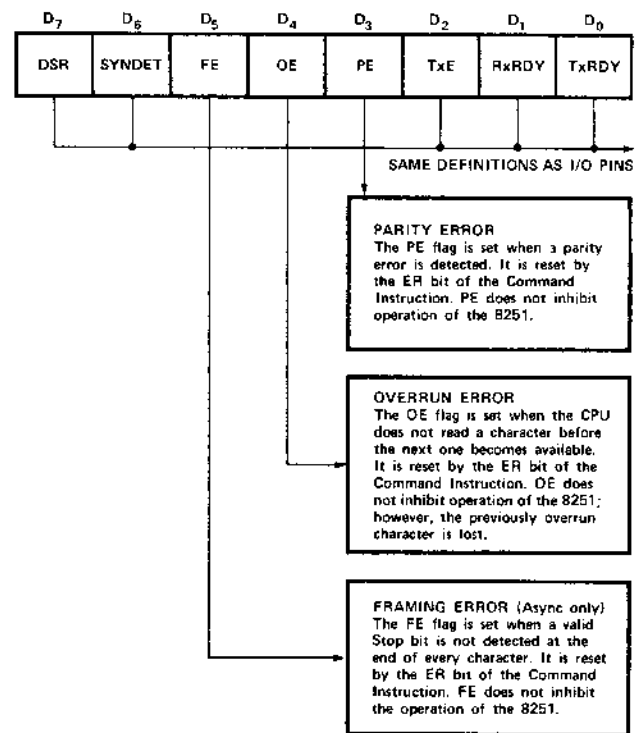

Status Read Format

SILICON GATE MOS 8251

APPLICATIONS OF THE 8251

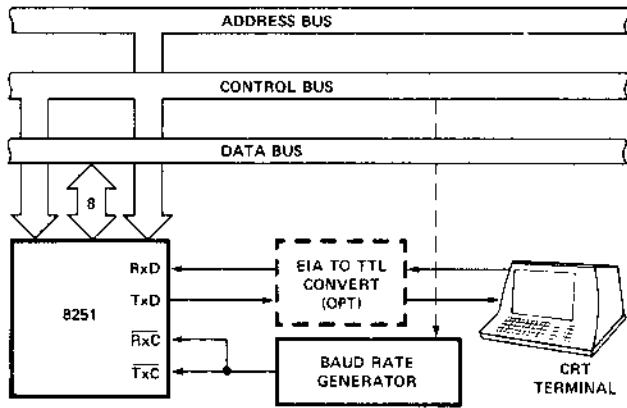

**Asynchronous Serial Interface to CRT Terminal,
DC-9600 Baud**

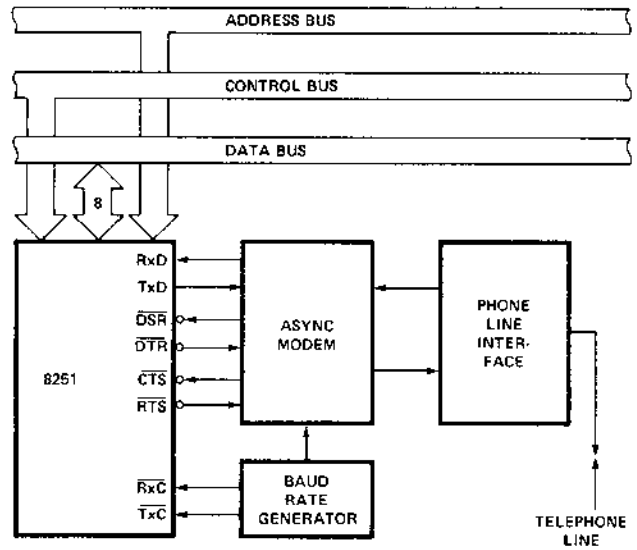

Asynchronous Interface to Telephone Lines

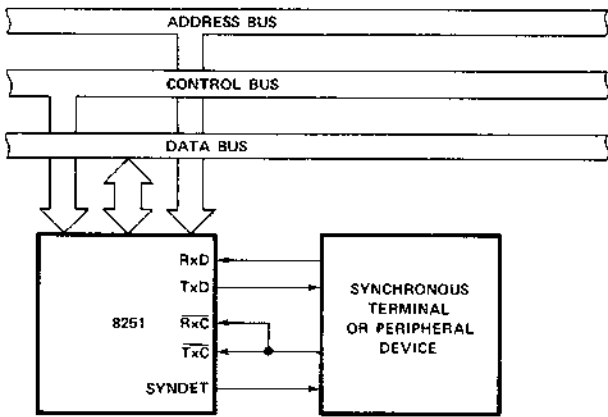

Synchronous Interface to Terminal or Peripheral Device

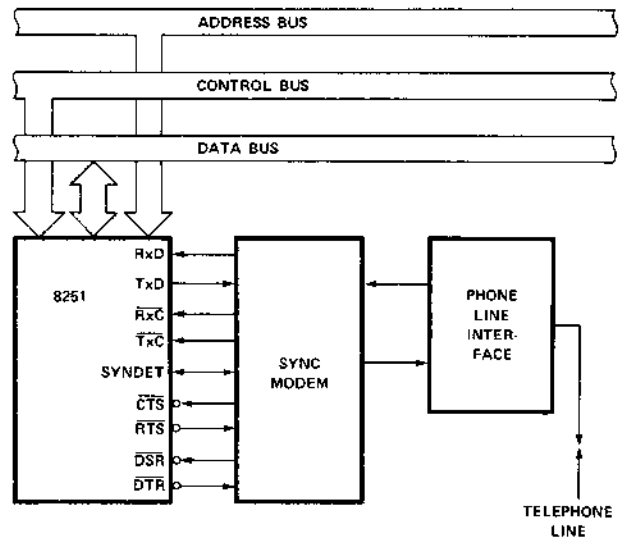

Synchronous Interface to Telephone Lines

SILICON GATE MOS 8251

D.C. Characteristics:

$T_A = 0^\circ\text{C}$ to 70°C ; $V_{CC} = 5.0\text{V} \pm 5\%$; $V_{SS} = 0\text{V}$

Symbol	Parameter	Min.	Typ.	Max.	Unit	Test Conditions
V_{IL}	Input Low Voltage	$V_{SS}-.5$		0.8	V	
V_{IH}	Input High Voltage	2.0		V_{CC}	V	
V_{OL}	Output Low Voltage			0.45	V	$I_{OL} = 1.6\text{mA}$
V_{OH}	Output High Voltage	2.2			V	$I_{OH} = -100\mu\text{A}$ (DB ₀₋₇) $I_{OH} = -100\mu\text{A}$ (Others)
I_{DL}	Data Bus Leakage			50	μA	$V_{OUT} = 4.5\text{V}$
I_{LI}	Input Load Current			10	μA	@ 5.5V
I_{CC}	Power Supply Current		45	80		

Capacitance

$T_A = 25^\circ\text{C}$; $V_{CC} = V_{SS} = 0\text{V}$

Symbol	Parameter	Min.	Typ.	Max.	Unit	Test Conditions
C_{IN}	Input Capacitance			10	pF	$f_c = 1\text{MHz}$
$C_{I/O}$	I/O Capacitance			20	pF	Unmeasured pins returned to V_{SS} .

SILICON GATE MOS 8251

A.C. Characteristics:

$T_A = 0^\circ\text{C}$ to 70°C ; $V_{CC} = 5.0\text{V} \pm 5\%$; $V_{SS} = 0\text{V}$

Symbol	Parameter	Min.	Typ.	Max.	Unit	Test Conditions
t_{CY}	Clock Period	.420		1.35	μs	
$t_{\phi W}$	Clock Pulse Width	220		300	ns	
$t_{R,tF}$	Clock Rise and Fall Time	0		50	ns	
t_{WR}	$\overline{\text{WRITE}}$ Pulse Width	430			ns	
t_{DS}	Data Set-Up Time for $\overline{\text{WRITE}}$	0			ns	
t_{DH}	Data Hold Time for $\overline{\text{WRITE}}$	65			ns	
t_{AW}	Address Stable before $\overline{\text{WRITE}}$	20			ns	
t_{WA}	Address Hold Time for $\overline{\text{WRITE}}$	35			ns	
t_{RD}	READ Pulse Width	430			ns	
t_{DD}	Data Delay from $\overline{\text{READ}}$	350			ns	$C_L = 100\text{pF}$
t_{DF}	$\overline{\text{READ}}$ to Data Floating	150			ns	$C_L = 100\text{pF}$
t_{AR1}	Address Stable before $\overline{\text{READ}}$, CE (C/D)	50			ns	
t_{RA1}	Address Hold Time for $\overline{\text{READ}}$, CE	5			ns	
t_{RA2}	Address Hold Time for $\overline{\text{READ}}$, C/D	370			ns	
t_{DTx}	TxD Delay from Falling Edge of TxC	1			μs	$C_L = 100\text{pF}$
t_{SRx}	Rx Data Set-Up Time to Sampling Pulse	2			μs	$C_L = 100\text{pF}$
t_{HRx}	Rx Data Hold Time to Sampling Pulse	2			μs	$C_L = 100\text{pF}$
f_{Tx}	Transmitter Input Clock Frequency 1X Baud Rate 16X and 64X Baud Rate	DC DC		56 615	KHz KHz	
f_{Rx}	Receiver Input Clock Frequency 1X Baud Rate 16X and 64X Baud Rate	DC DC		56 615	KHz KHz	
t_{Tx}	TxRDY Delay from Center of Data Bit			16	CLK Period	$C_L = 50\text{pF}$
t_{Rx}	RxRDY Delay from Center of Data Bit	15		20	CLK Period	
t_{IS}	Internal Syndet Delay from Center of Data Bit	20		25	CLK Period	
t_{ES}	External Syndet Set-Up Time before Falling Edge of RxC			15	CLK Period	

Note: The TxC and RxC frequencies have the following limitation with respect to CLK.
 For ASYNC Mode, t_{Tx} or $t_{Rx} \geq 4.5 t_{CY}$
 For SYNC Mode, t_{Tx} or $t_{Rx} \geq 30 t_{CY}$

READ AND WRITE TIMING

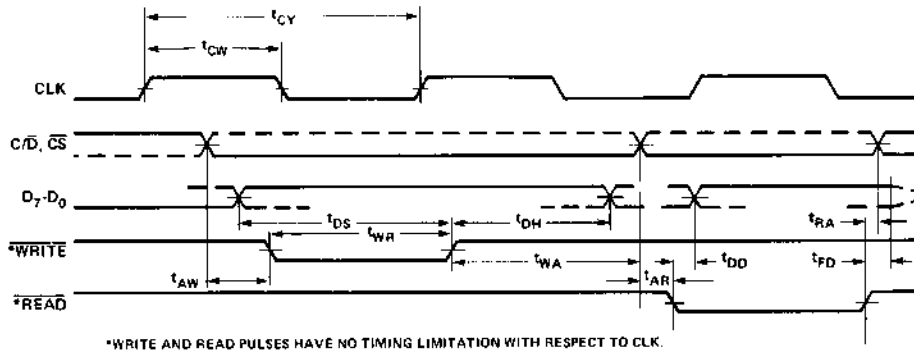

TRANSMITTER CLOCK AND DATA

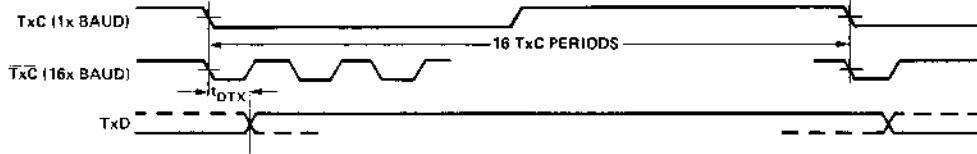

RECEIVER CLOCK AND DATA

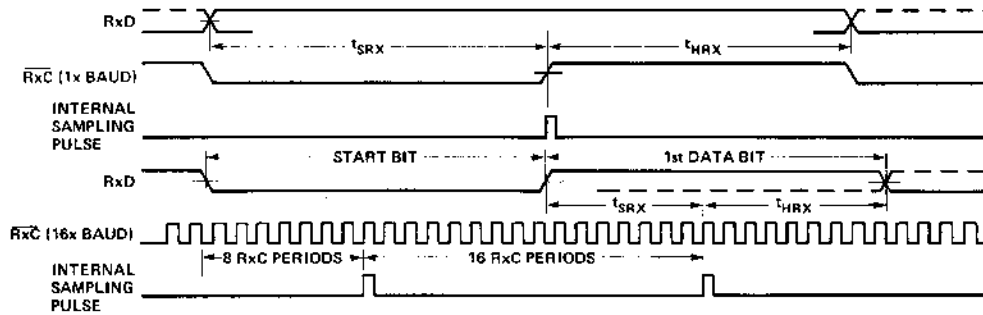

Tx RDY AND Rx RDY TIMING (ASYNC MODE)

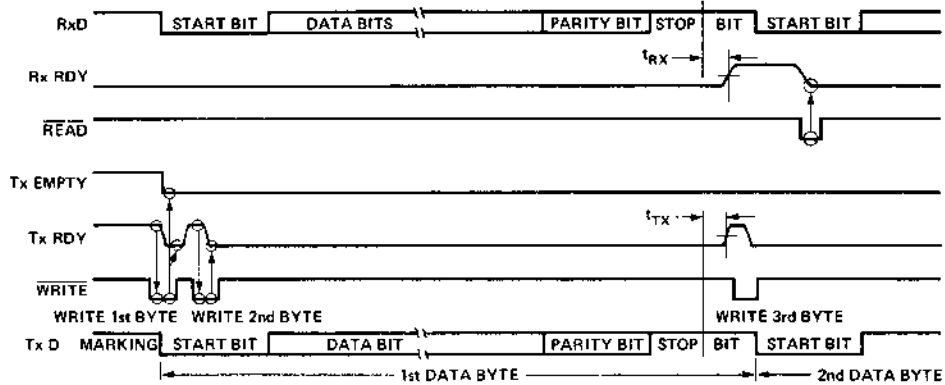

INTERNAL SYNC DETECT

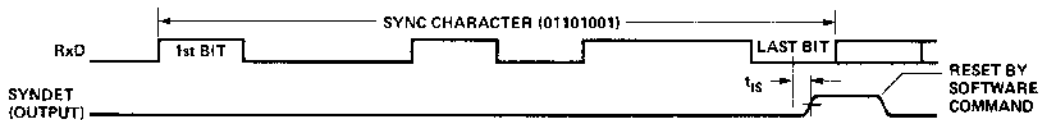

EXTERNAL SYNC DETECT

