

# Am9044 • Am9244

## 4096 x 1 Static R/W Random Access Memory

### DISTINCTIVE CHARACTERISTICS

- **LOW OPERATING POWER (MAX)**
  - Am9044/Am9244**      **385mW (70mA)**
  - Am90L44/Am92L44**    **275mW (50mA)**
- **LOW STANDBY POWER (MAX)**
  - Am92L44**              **110mW (20mA)**
- Access times down to 200ns (max)
- Military temperature range available to 250ns (max)
- Am9044 is a direct plug-in replacement for 4044
- Am9244 pin and function compatible with Am9044 and 4044 plus  $\overline{CS}$  power down feature
- Fully static – no clocking
- Identical access and cycle time
- High output drive – 4.0mA sink current @ 0.4V
- TTL identical interface logic levels
- 100% MIL-STD-883 reliability assurance testing

### GENERAL DESCRIPTION

The Am9044 and Am9244 are high performance, static, N-Channel, read/write, random access memories organized as 4096 x 1. Operation is from a single 5V supply, and all input/output levels are identical to standard TTL specifications. Low power versions of both devices are available with power savings of about 30%. The Am9044 and Am9244 are the same except that the Am9244 offers an automatic  $\overline{CS}$  power down feature.

The Am9244 remains in a low power standby mode as long as  $\overline{CS}$  remains high, thus reducing its power requirements. The Am9244 power decreases from 385mW to 165mW in the standby mode, and the Am92L44 from 275mW to 110mW. The  $\overline{CS}$  input does not affect the power dissipation of the Am9044.

Data readout is not destructive and the same polarity as data input.  $\overline{CS}$  provides for easy selection of an individual package when the outputs are OR-tied. The outputs of 4.0mA for Am9244 and Am9044 provide increased short circuit current for improved capacitive drive.

### BLOCK DIAGRAM

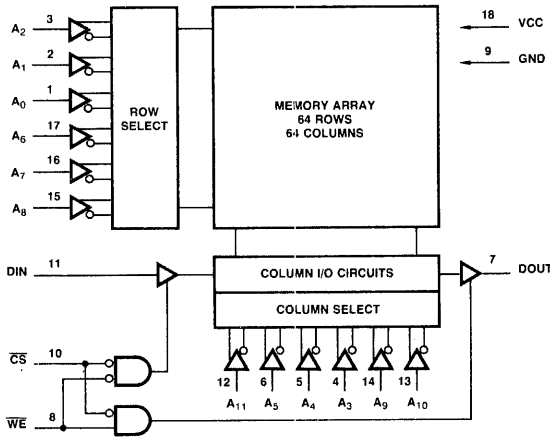

MOS-256

### CONNECTION DIAGRAM

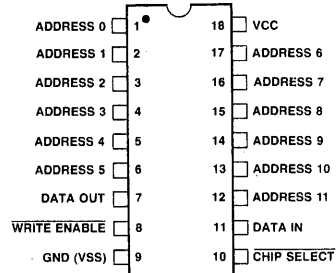

Top View  
Pin 1 is marked for orientation.

MOS-257

### ORDERING INFORMATION

Ambient Temperature	Package Type	ICC Current Level	Access Times							
			Am9044				Am9244			
			450ns	300ns	250ns	200ns	450ns	300ns	250ns	200ns
0°C ≤ T <sub>A</sub> ≤ +70°C	Plastic	70mA	AM9044BPC	AM9044CPC	AM9044DPC	AM9044EPC	AM9244BPC	AM9244CPC	AM9244DPC	AM9244EPC
		50mA	AM90L44BPC	AM90L44CPC	AM90L44DPC	AM90L44EPC	AM92L44BPC	AM92L44CPC	AM92L44DPC	AM92L44EPC
	Hermetic	70mA	AM9044BDC	AM9044CDC	AM9044DDC	AM9044EDC	AM9244BDC	AM9244CDC	AM9244DDC	AM9244EDC
		50mA	AM90L44BDC	AM90L44CDC	AM90L44DDC		AM92L44BDC	AM92L44CDC	AM92L44DDC	
-55°C ≤ T <sub>A</sub> ≤ +125°C	Hermetic	90mA	AM9044BDM	AM9044CDM	AM9044DDM		AM9244BDM	AM9244CDM	AM9244DDM	
		60mA	AM90L44BDM	AM90L44CDM	AM90L44DDM		AM92L44BDM	AM92L44CDM		

**MAXIMUM RATINGS** beyond which useful life may be impaired

Storage Temperature	-65°C to +150°C
Ambient Temperature Under Bias	-55°C to +125°C
VCC with Respect to VSS	-0.5V to +7.0V
All Signal Voltages with Respect to VSS	-0.5V to +7.0V
Power Dissipation (Package Limitation)	1.0W
DC Output Current	10mA

The products described by this specification include internal circuitry designed to protect input devices from damaging accumulations of static charge. It is suggested nevertheless, that conventional precautions be observed during storage, handling and use in order to avoid exposure to excessive voltages.

**OPERATING RANGE**

Part Number	Ambient Temperature	VSS	VCC	Part Number	Ambient Temperature	VSS	VCC
Am9044DC/PC Am90L44DC/PC Am9244DC/PC Am92L44DC/PC	0°C ≤ T <sub>A</sub> ≤ +70°C	0V	+5.0V ±10%	Am9044DM Am90L44DM Am9244DM Am92L44DM	-55°C ≤ T <sub>A</sub> ≤ +125°C	0V	+5.0V ±10%

**ELECTRICAL CHARACTERISTICS** over operating range

Parameter	Description	Test Conditions	Am9244XX Am92L44XX			Am9044XX Am90L44XX			Units		
			Min.	Typ.	Max.	Min.	Typ.	Max.			
IOH	Output High Current	VOH = 2.4V	VCC = 4.5V	70°C	-1.0			-1.0		mA	
		VOH = 2.4V	VCC = 4.5V	125°C	-4			-4			
IOL	Output Low Current	VOL = 0.4V	T <sub>A</sub> = +70°C		4.0			4.0		mA	
			T <sub>A</sub> = +125°C		3.2			3.2			
VIH	Input High Voltage				2.0		VCC	2.0		VCC	Volts
VIL	Input Low Voltage				-0.5		0.8	-0.5		0.8	Volts
IIX	Input Load Current	VSS ≤ VI ≤ VCC					10			10	μA
IOZ	Output Leakage Current	0.4V ≤ VO ≤ VCC Output Disabled	T <sub>A</sub> = +125°C		-50		50	-50		50	μA
			T <sub>A</sub> = +70°C		-10		10	-10		10	
CI	Input Capacitance (Note 1)	Test Frequency = 1.0MHz T <sub>A</sub> = 25°C, All pins at 0V				3.0	5.0		3.0	5.0	pF
CI/O	I/O Capacitance (Note 1)					5.0	6.0		5.0	6.0	

6

**ELECTRICAL CHARACTERISTICS** over operating range

Parameter	Description	Test Conditions	Am92L44		Am9244		Am90L44		Am9044		Units	
			Typ.	Max.	Typ.	Max.	Typ.	Max.	Typ.	Max.		
ICC	VCC Operating Supply Current	Max. VCC $\overline{CS} \leq V_{IL}$ for Am9244/92L44	T <sub>A</sub> = 0°C			50		70		50		mA
			T <sub>A</sub> = -55°C			60		80		60		
IPD	Automatic $\overline{CS}$ Power Down Current	Max. V <sub>CC</sub> ( $\overline{CS} \geq V_{IH}$ )	T <sub>A</sub> = 0°C			20		30		-		mA
			T <sub>A</sub> = -55°C			22		33		-		

## Notes:

- Typical values are for T<sub>A</sub> = 25°C, nominal supply voltage and nominal processing parameters.
- For test purposes, not more than one output at a time should be shorted. Short circuit test duration should not exceed 30 seconds.
- Test conditions assume signal transition times of 10ns or less, timing reference levels of 1.5V and output loading of one standard TTL gate plus 100pF.
- The internal write time of the memory is defined by the overlap of  $\overline{CS}$  low and  $\overline{WE}$  low. Both signals must be low to initiate a write and either signal can terminate a write by going high. The data input setup and hold timing should be referenced to the rising edge of the signal that terminates the write.
- Chip Select access time (t<sub>CO</sub>) is longer for the Am9244 than for the Am9044. The specified address access time will be valid only when Chip Select is low soon enough for t<sub>CO</sub> to elapse.

**Am9044 • Am9244**

**SWITCHING CHARACTERISTICS** over operating range (Note 3)

Parameter	Description	Am9044B Am9244B		Am9044C Am9244C		Am9044D Am9244D		Am9044E Am9244E		Units
		Min.	Max.	Min.	Max.	Min.	Max.	Min.	Max.	
<b>Read Cycle</b>										
tRC	Address Valid to Address Do Not Care Time (Read Cycle Time)	450		300		250		200		ns
tA	Address Valid to Data Out Valid Delay (Address Access Time)		450		300		250		200	
tCO	Chip Select Low to Data Out Valid (Note 5)	Am9044	100	100	70	70				
		Am9244	450	300	250	200				
tCX	Chip Select Low to Data Out On	20		20		20		20		
tOTD	Chip Select High to Data Out Off		100		80		60		60	
tOHA	Address Unknown to Data Out Unknown Time	20		20		20		20		

**Write Cycle**

tWC	Address Valid to Address Do Not Care Time (Write Cycle Time)	450		300		250		200		ns
tW	Write Enable Low to Write Enable High Time (Note 4)	Am9044	200	150	100	100				
		Am9244	250	200	150	150				
tWR	Write Enable High to Address Do Not Care Time	0		0		0		0		
tOTW	Write Enable Low to Data Out Off Delay		100		80		60		60	
tDW	Data In Valid to Write Enable High Time	200		150		100		100		
tDH	Write Enable Low to Data In Do Not Care Time	0		0		0		0		
tAW	Address Valid to Write Enable Low Time	0		0		0		0		
tPD	Chip Select High to Power Low Delay (Am9244 only)		200		150		100		100	
tPU	Chip Select Low to Power High Delay (Am9244 only)	0		0		0		0		
tCW	Chip Select Low to Write Enable High Time (Note 4)	Am9044	200	150	100	100				
		Am9244	250	200	150	150				
tWO	Write Enable High To Output Turn On		100		100		70		70	

**SWITCHING WAVEFORMS**

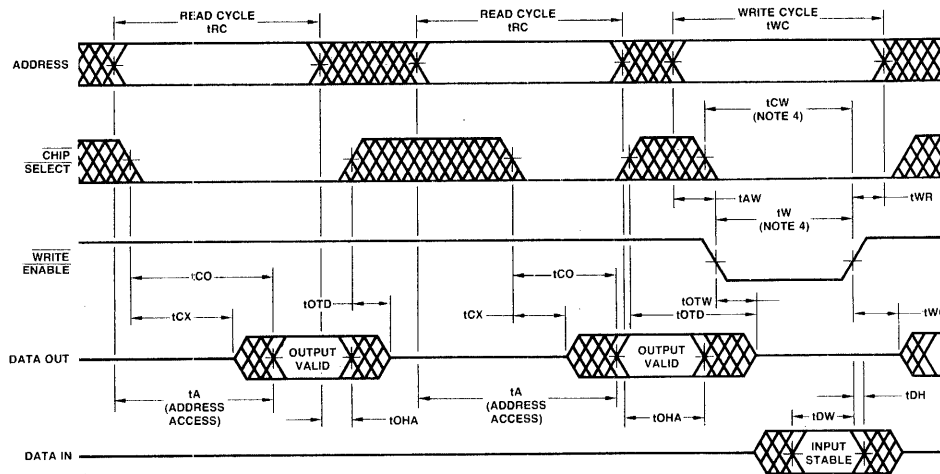

**POWER DOWN WAVEFORM (Am9244 ONLY)**

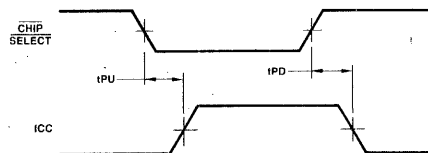

MOS-258

TYPICAL CHARACTERISTICS

Typical ICC Versus VCC Characteristics

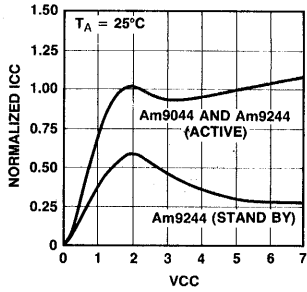

Typical tacc Versus VCC Characteristics

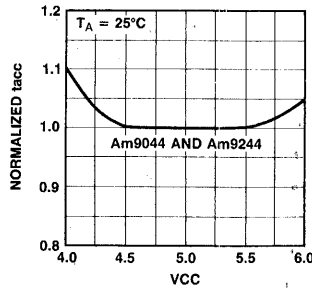

Typical C Load Versus Normalized tacc Characteristics

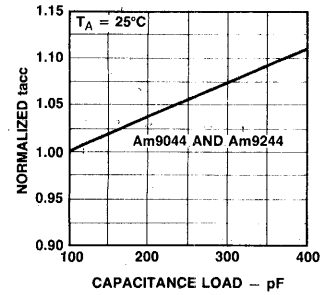

Normalized tacc Versus Ambient Temperature

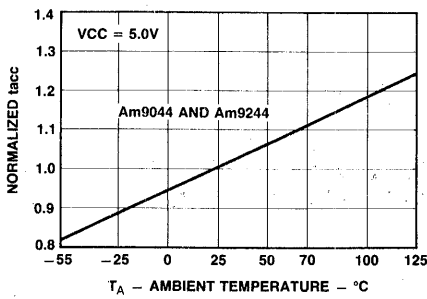

Normalized ICC Versus Ambient Temperature

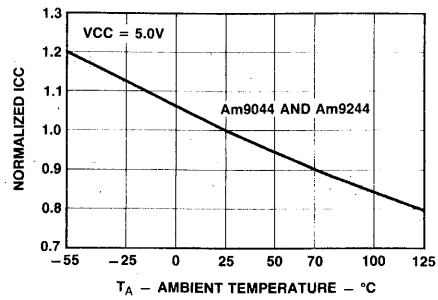

MOS-259

BIT MAP

Address Designators	
External	Internal
A0	A2
A1	A1
A2	A0
A3	A8
A4	A9
A5	A10
A6	A3
A7	A4
A8	A5
A9	A7
A10	A6
A11	A11

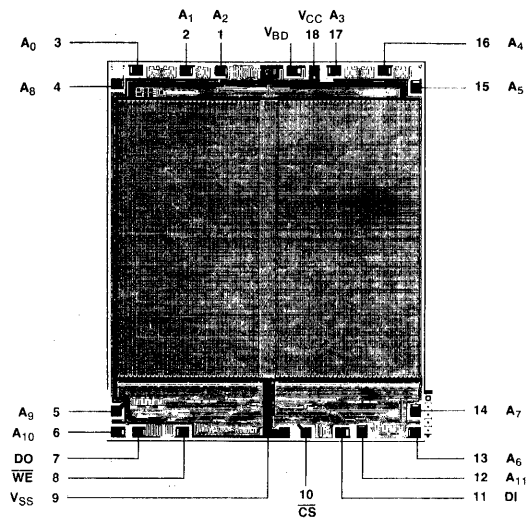

Figure 1. Bit Mapping Information.