

**BULLETIN 281B  
VOL. 2**

**TECHNICAL MANUAL  
MODEL 35  
KEYBOARD SEND-RECEIVE (KSR) AND  
RECEIVE-ONLY (RO)  
TELETYPEWRITER SETS**



**TELETYPE<sup>®</sup>  
CORPORATION**  
5555 TOWHY AVENUE, SKOKIE, ILLINOIS

281B  
VOLUME 2

INTRODUCTION

Bulletin 281B is a technical manual that provides descriptive, installing and maintenance information for the Model 35 Keyboard Send-Receive (KSR) and Receive-Only (RO) Teletypewriter Sets and their components.

The bulletin consists of two volumes. Volume 1 contains description, operation, installation, lubrication, and disassembly and reassembly. Volume 2 contains adjustments. Change 10 is issued to Volume 2 to revise adjustment requirements for the keyboard codebar and codelever mechanism and add information about the wall mount cabinet and call control unit apparatus mounting rack.

Each volume is made up of a group of appropriate independent sections. They are separately identified by title and section number, and the pages of each section are numbered consecutively, independent of other sections. Individual copies of these sections can be obtained upon request.

The identifying number of a section, a 9-digit number, appears at the top of each page of the section, in the left corner of the left-hand pages and the right corner of the right-hand pages. The sections are placed in the manual in ascending numerical order.

To locate specific information refer to the table of contents on the following page. Find the name of the involved component in column one and the title of the section in column two. The correct 9-digit section number will then be found in column three. Turn to page one of the section indicated, where the contents of that section will be found (except where a section is small and does not require a listing of contents).

TABLE OF CONTENTS

FILING INSTRUCTIONS

1. The following filing instructions apply to changes sent to the field.
2. Asterisk (\*) in the table of contents indicates changes.
3. When the issue of a section changes, replace the old issue with the attached new one.
4. In the case of addendums, turn to the affected section and follow the instructions on the first page of the attached addendum.
5. Replace the old table of contents with this new one.

<u>Equipment</u>	<u>Content</u>	<u>Section</u>	<u>Issue</u>
Typing Unit (LP)	Adjustments	574-220-700TC	9
Keyboard and Base (LK, LB)	Adjustments	574-221-700TC	8*
Cabinet (LAC)	Adjustments	574-229-700TC	5*
Answer-Back Unit	Adjustments	574-235-700TC	6

35 TYPING UNIT (LP)

ADJUSTMENTS

CONTENTS	PAGE	CONTENTS	PAGE
1. GENERAL . . . . .	4	Paper finger latch spring (sprocket feed) . . . . .	82
2. BASIC UNITS . . . . .	8	Paper finger shaft spring (sprocket feed) . . . . .	82
Codebar Mechanism		Paper finger spring (friction feed) . . .	77
Codebar detent . . . . .	78	Paper guide (sprocket feed) . . . . .	86
Codebar detent spring . . . . .	78	Paper pressure bail spring (friction feed) . . . . .	77
Codebar shift lever . . . . .	23	Paper straightener collar (friction feed) . . . . .	76
Codebar shift lever drive arm . . . . .	20	Paper straightener lever spring (friction feed) . . . . .	76
Codebar yield spring . . . . .	78	Platen detent bail spring . . . . .	68
Common transfer lever spring . . . . .	21	Platen endplay (sprocket feed) . . . . .	84
Intermediate arm backstop bracket . . .	22	Pressure roller lever spring (friction feed) . . . . .	77
Intermediate latch eccentric . . . . .	24	Printed line (sprocket feed) . . . . .	84
Intermediate reset bail eccentric . . .	25	Right margin with automatic carriage return-line feed ring . . . . .	75
Intermediate reset bail spring . . . . .	25	Single-double line feed stripper bail assembly springs . . . . .	74
Intermediate reset lever spring . . . . .	25	Sprocket pin separation (sprocket feed) . . . . .	84
Transfer lever eccentric . . . . .	21	Sprocket pin spring (sprocket feed) . . .	86
Transfer lever spring . . . . .	21		
Function Mechanism		Main Shaft and Trip Shaft Mechanisms	
Function bar spring . . . . .	71	Antideflexion plate . . . . .	28
Function contact spring . . . . .	72	Clutch drum position (except selector) . . . . .	35
Function lever spring . . . . .	71	Clutch latchlever spring (except selector) . . . . .	26
Function pawl spring . . . . .	71	Clutch shoe lever . . . . .	34
Function pawl timing contact . . . . .	72	Clutch shoe lever spring . . . . .	35
Function reset ball blade . . . . .	43	Clutch shoe spring . . . . .	35
Function reset ball spring . . . . .	43	Clutch trip lever spring . . . . .	30
Stripper blade drive cam position . . .	70	Clutch trip shaft set collars . . . . .	29
Stripper slide bail arm . . . . .	87	Codebar clutch cam follower spring . . . . .	27
Stripper slide bail torsion spring . . .	88	Codebar clutch trip lever . . . . .	26
Stripper slide spring . . . . .	88	Function clutch trip lever . . . . .	27
Line Feed and Platen Mechanism		Function clutch trip lever trip arm . . .	28
Left margin (sprocket feed) . . . . .	83	Intermediate lever spring . . . . .	30
Line feed bar bellcrank spring (friction feed) . . . . .	68	Line feed clutch trip lever adjusting screw . . . . .	32
Line feed bar bellcrank spring (sprocket feed) . . . . .	86	Line feed clutch trip lever eccentric post . . . . .	32
Line feed bar bumper (six stop clutch only) . . . . .	69		
Line feed bar release lever spring . . .	68		
Line feed clutch gear phasing . . . . .	37		
Line feed spur gear detent eccentric . .	68		
Paper finger (friction feed) . . . . .	77		
Paper finger (sprocket feed) . . . . .	85		

SECTION 574-220-700TC

CONTENTS	PAGE
Spacing clutch trip cam follower spring . . . . .	31
Spacing clutch trip lever . . . . .	30
Trip shaft lever spring . . . . .	26
Typebox clutch trip lever eccentric post . . . . .	33
Typebox clutch trip lever trip arm . . . . .	33
 Positioning Mechanism	
Bail arm assembly spring . . . . .	49
Decelerating slide spring . . . . .	47
Horizontal positioning drive linkage . . . . .	45
Horizontal positioning drive linkage spring . . . . .	45
Horizontal positioning locklever spring . . . . .	38
Horizontal shift link shock absorber spring . . . . .	47
Horizontal stop slide spring . . . . .	76
Left vertical positioning lever eccentric stud . . . . .	40
Reversing slide adjusting stud . . . . .	44
Reversing slide brackets . . . . .	44
Reversing slide detent spring . . . . .	44
Right vertical positioning lever eccentric stud . . . . .	39
Rocker shaft bracket eccentric stud . . . . .	38
Rocker shaft left bracket . . . . .	37
Shift drive pawl guide bracket . . . . .	49
Shift drive pawl operating bail . . . . .	48
Shift linkage (final) . . . . .	59
Shift linkage (preliminary) . . . . .	46
Shift linkage spring . . . . .	59
Shift pawl selector link yield spring . . . . .	50
Shift rocker bail spring . . . . .	48
Shift rocker bar bearing bracket . . . . .	46
Shift rocker lever . . . . .	48
Shift selector arm bellcrank . . . . .	50
Vertical positioning lever spring . . . . .	39
Vertical positioning locklever . . . . .	41
Vertical positioning locklever spring . . . . .	40
 Printing Mechanism	
Printing arm . . . . .	61
Printing carriage lower roller . . . . .	54
Printing carriage position . . . . .	58
Printing hammer bearing stud . . . . .	58
Printing hammer operating bail latch spring . . . . .	60
Printing hammer operating bail spring . . . . .	60
Printing hammer operating bail spring (not as illustrated) . . . . .	60
Printing hammer plunger spring . . . . .	60
Printing hammer stop bracket . . . . .	61

CONTENTS	PAGE
Printing hammer yield spring . . . . .	60
Printing track . . . . .	60
Print suppression blocking bail spring . . . . .	81
Print suppression blocking levers . . . . .	80
Print suppression blocking levers spring . . . . .	80
Print suppression mechanism . . . . .	80
Ribbon feed lever bracket . . . . .	66
Ribbon feed lever spring . . . . .	66
Ribbon lever spring . . . . .	67
Ribbon ratchet wheel friction spring . . . . .	66
Ribbon reverse detent . . . . .	65
Ribbon reverse detent lever spring . . . . .	65
Ribbon reverse spur gear . . . . .	65
Ribbon tension spring . . . . .	67
Stabilizing spring . . . . .	54
Typebox alignment . . . . .	64
Typebox carriage roller arm spring . . . . .	54
Typebox clutch suppression arm . . . . .	81
Type pallet spring . . . . .	61
 Selector Mechanism	
Marking locklever spring . . . . .	17
Pushlever reset bail spring . . . . .	18
Rangefinder knob . . . . .	8
Selector armature . . . . .	9
Selector armature downstop (final) . . . . .	15
Selector armature downstop (preliminary) . . . . .	10
Selector armature spring (double button) (final) . . . . .	12
Selector armature spring (double button) (preliminary) . . . . .	12
Selector armature spring (single button) . . . . .	11
Selector cam lubricator . . . . .	22
Selector clutch drum . . . . .	16
Selector clutch latchlever spring . . . . .	18
Selector clutch stop arm . . . . .	8
Selector lever spring . . . . .	16
Selector magnet bracket . . . . .	13
Selector magnet bracket (vertical adjustment) . . . . .	14
Selector pushlever spring . . . . .	16
Selector receiving margin . . . . .	17
Spacing locklever spring . . . . .	18
Start lever spring . . . . .	19
 Spacing Mechanism	
Automatic CR-LF bellcrank spring . . . . .	62
Carriage draw-wire rope . . . . .	52
Carriage return latch bail . . . . .	55
Carriage return latch bail spring . . . . .	55

CONTENTS	PAGE	CONTENTS	PAGE
Carriage return lever . . . . .	56	Tabulator pawl vertical adjustment (final) . . . . .	107
Carriage return spring . . . . .	53	Tabulator stops settings . . . . .	109
Dashpot vent screw . . . . .	57	Keyboard Lock Mechanism	
Left margin . . . . .	62	Keyboard locklever spring . . . . .	113
Lower draw-wire rope pulley bail spring . . . . .	52	Local Backspace Mechanism	
Margin indicator lamp . . . . .	79	Camming bail spring . . . . .	114
Oscillating rail slide position . . . . .	51	Camming bail stop arm . . . . .	114
Right margin . . . . .	63	Lower Solenoid (for Applicable Units)	
Spacing cutout transfer bail spring . . . . .	63	Lower solenoid . . . . .	120
Space suppression bypass spring . . . . .	63	Solenoid spring . . . . .	120
Spacing feed pawl release link spring . . . . .	53	Low Paper and Paper Out Alarm Mechanisms	
Spacing feed pawl spring . . . . .	51	Low paper and paper out alarm (sprocket feed) . . . . .	98
Spacing gear clearance . . . . .	36	Paper out alarm assembly (friction feed) . . . . .	100
Spacing gear phasing . . . . .	36	Paper out alarm bellcrank follower spring (friction feed) . . . . .	100
Spacing suppression bail spring . . . . .	73	Paper out alarm sensing lever spring (sprocket feed) . . . . .	98
Spacing trip lever bail cam plate . . . . .	42	Paper Jam Alarm (Sprocket Feed)	
Spacing trip lever bail spring . . . . .	42	Bail spring . . . . .	134
Spacing trip lever spring . . . . .	42	Switch position . . . . .	133
Transfer slide spring . . . . .	57	Wire bail . . . . .	132
<b>3. VARIABLE FEATURES</b>		Paper Out Alarm Mechanism (Friction Type) (Later Design)	
Form-Out Mechanism		Lever . . . . .	99
Form feed-out nonrepeat slide spring . . . . .	96	Lever spring . . . . .	99
Form-out lever backstop . . . . .	96	Switch . . . . .	99
Nonrepeat slide . . . . .	97	Print-Nonprint Solenoid Mechanism	
Solenoid lever . . . . .	96	Contact button and solenoid pin alignment . . . . .	125
Horizontal Tabulator Mechanism		Solenoid contact . . . . .	121
Cam plate stripper bail . . . . .	104	Solenoid plunger . . . . .	121
Columnar tabulator stops . . . . .	109	Solenoid energized . . . . .	123
Horizontal tab blocking lever return spring . . . . .	107	Solenoid de-energized . . . . .	124
Horizontal tab intermediate bail spring . . . . .	102	Suppression bar return spring (for units employing the print suppress solenoid mechanism) . . . . .	122
Horizontal tab operating lever cam plate spring . . . . .	104	Timing Contact Mechanism (Operated by Selector)	
Horizontal tab operating lever cam plate . . . . .	103	Alignment of operating lever with cam . . . . .	127
Horizontal tab operating lever extension link spring . . . . .	101	"B" contact springs . . . . .	126
Horizontal tab operating lever link . . . . .	101	Contact assembly position . . . . .	127
Horizontal tab pawl spring . . . . .	107	Correction of timing . . . . .	129
Horizontal tab slide arm spring . . . . .	104	"M" contact springs . . . . .	126
Horizontal tab spacing trip lever . . . . .	103		
Right margin adjustment . . . . .	105		
Right margin tabulator stop (with wide shelf) . . . . .	109		
Space suppression bypass spring . . . . .	105		
Spacing cutout transfer bail set collar . . . . .	105		
Tabulator pawl horizontal adjustment . . . . .	108		
Tabulator pawl (preliminary) . . . . .	106		

CONTENTS	PAGE
Operating lever spring . . . . .	127
"S" - "B" contact springs . . . . .	126
"S" - "M" contact gap . . . . .	126
Timing verification, 11.00 unit code . .	128
Twin "B" contact springs . . . . .	126
Twin springs ("M" contacts) . . . . .	126
Transmitter Control Contacts (Later Design)	
Contact bracket . . . . .	118
Normally open contact gap . . . . .	118
Switch contact pressure . . . . .	118
Transmitter Distributor Transfer Control Contacts	
Contact assembly bracket (final) . . . .	110
Contact assembly bracket (preliminary) . . . . .	110
Normally closed contact spring . . . . .	110
Normally open contact gap . . . . .	110
Normally open contact spring . . . . .	110
Transfer contact spring . . . . .	110
Transmitter control contact gap . . . .	110
Transmitter Distributor Transfer Control Contacts (Later Design)	
Contact assembly bracket (final) . . . .	112
Contact assembly bracket (preliminary) . . . . .	111
Contact spring . . . . .	111
Normally open contact gap . . . . .	111
Normally open contact spring . . . . .	111
Transfer contact spring . . . . .	111
Transmitter control contact gap . . . .	112
Two Color Ribbon Mechanism	
Contact activating lever . . . . .	130
Contact gap . . . . .	131
Contact spring . . . . .	131
Ribbon levers . . . . .	130
Universal Function Bar	
Coding . . . . .	135
Upper Solenoid (for Applicable Units)	
Solenoid spring . . . . .	119
Upper solenoid . . . . .	119
Vertical Tabulator Mechanism	
Blocking lever . . . . .	116
Blocking lever spring . . . . .	117
Form-out pawl spring . . . . .	95
Form-out stop plate position . . . . .	116

CONTENTS	PAGE
Form start gear play . . . . .	115
Function contact spring . . . . .	117
Indexing disc . . . . .	115
Line feed clutch trip lever spring . . .	117
Mounting bracket . . . . .	115
Pointer . . . . .	116
Switch contact pressure . . . . .	116
Tabulation stop plate position . . . . .	117
Transmitter control switch (single contact type) . . . . .	117
Vertical tabulator bail spring . . . . .	95
Vertical tabulator slide retainer . . . .	115
Vertical Tabulator Mechanism (For Bell System Switched Network Service)	
Blocking arm (form-out) . . . . .	93
Blocking arm (vertical tab) . . . . .	93
Form feed-out torsion spring . . . . .	95
Form-out pawl spring . . . . .	95
Form start gear play . . . . .	90
Indexing disc . . . . .	90
Mounting bracket . . . . .	89
Off normal contact	
Contact bracket . . . . .	94
Follower lever . . . . .	94
Long contact spring . . . . .	94
Short contact spring . . . . .	94
Pointer adjustment . . . . .	90
Transmitter control switch	
Contact bracket . . . . .	91
Normally closed contact gap . . . . .	92
Normally closed contact spring . . .	92
Normally open contact gap . . . . .	91
Normally open contact spring . . . .	91
Transfer contact spring . . . . .	91
Vertical tab blocking lever arm . .	91
Vertical tab blocking lever spring .	91
Vertical tabulator bail spring . . . . .	95
Vertical tabulator slide retainer . . . .	89

1. GENERAL

1.01 This section contains the specific requirements and adjustments for the 35 typing unit.

1.02 This section is reissued to include paper jam alarm, to add recent engineering changes and to delete the adjustment for typebox position (sprocket feed). Arrows in the margins indicate changes and additions.

**CAUTION: REMOVE POWER FROM SET OR UNIT BEFORE MAKING ADJUSTMENTS.**

1.03 The adjustments in this section are arranged in a sequence that should be followed if a complete readjustment of the unit is undertaken. A complete adjusting procedure should be read before attempting to make the adjustment. After an adjustment is completed, be sure to tighten any nuts or screws that may have been loosened, unless otherwise instructed.

1.04 The adjusting illustrations indicate tolerances, positions of moving parts, spring tensions, and the angle at which scales should be applied. The tools required to make adjustments and check spring tensions are not supplied with the equipment, but are listed in Section 570-005-800TC. Springs which do not meet the requirements, and for which there are no adjusting procedures, should be discarded and replaced by new springs.

1.05 References made to left, right, up, down, front, rear, etc, apply to the unit in its normal operating position as viewed from the front.

1.06 When a requirement calls for a clutch to be disengaged, the clutch shoe lever must be fully latched between its trip lever and latch-lever so that the clutch shoes release their tension on the clutch drum. When engaged, the clutch shoe lever is unlatched and the clutch shoes are wedged firmly against the clutch drum.

**Note:** When the main shaft is rotated by hand, the clutch does not fully disengage upon reaching its stop position. In order to relieve drag and permit the main shaft to rotate freely, apply pressure on the lug of the clutch disc with a screwdriver to cause it to engage its latch lever and fully disengage the clutch.

1.07 To manually operate the typing unit proceed as follows.

(a) Attach the TP312709 armature clip to the selector magnet armature by carefully placing the spring loop over the magnet terminal insulator. Press down to engage the hook of the clip on the underside of the armature and release. The spring tension of the armature clip will hold the selector armature in the marking (attracted) position.

(b) While holding the selector magnet armature operated by means of the armature clip, use the handwheel, included with the special tools for servicing 28 teletypewriter apparatus, to manually rotate the main shaft in a counterclockwise direction until all the

clutches are brought to their disengaged position.

(c) Fully disengage all clutches in accordance with 1.06, Note.

(d) Release the selector magnet armature momentarily to permit the selector clutch to engage.

(e) Rotate the main shaft slowly until all the pushlevers have fallen to the left of their selecting levers.

(f) Strip the pushlevers from their selector levers, which are spacing in the code combination of the character function that is being selected, and allow the pushlevers to move to the right.

(g) The pushlevers and the selector levers move in succession starting with the no. 1 to the no. 7; the no. 8 is always marking and is not equipped with a selector lever.

(h) Continue to rotate the main shaft until all operations initiated by the selector action clear through the unit.

1.08 Where adjustment instructions call for removal of components, assemblies, subassemblies or parts, all adjustments which the removal of these parts might facilitate should be made before the parts are replaced or as the equipment is reassembled. When a part mounted on shims is removed, the number of shims and their location should be noted so that the identical pile-up can be made when the part is replaced.

1.09 All electrical contact points should meet squarely. Contacts with the same diameter should not be out of alignment more than 25 percent of the contact diameter. Check contacts for pitting and corrosion and clean or burnish them before making specified adjustment or tolerance measurement. Avoid sharp kinks or bends in the contact springs.

**CAUTION: KEEP ALL ELECTRICAL CONTACTS FREE OF OIL AND GREASE.**

1.10 When making a complete adjustment of the unit, the following conditioning operations should be performed to prevent damage.

(a) Loosen the shift lever drive arm clamp screw (2.13).



SECTION 574-220-700TC

- (b) Move the right and left vertical positioning lever eccentric studs (2.32 and 2.33) in rocker shaft brackets to their lowest position.
- (c) Loosen the two bearing stud mounting screws and the two connecting strip clamp screws in the horizontal positioning drive linkage (2.38).
- (d) Loosen the clamp screws and move the reversing slide brackets to their uppermost position (2.37).
- (e) Loosen the function reset bail blade mounting screws (2.36).
- (f) Loosen the carriage return lever clamp screw (2.49).
- (g) Loosen the clamp screws in the oscillating rail slide (2.44).
- (h) Loosen the reversing slide adjusting stud (2.37).
- (i) Loosen clamp and pivot screws on shift arm bearing bracket and move to extreme downward position (2.39).
- (j) Loosen the clamp screw on the shift drive pawl operating bail (2.41).
- (k) Check the following adjustments during each lubricating period.
  - (1) Printing carriage position (2.51).
  - (2) Printing hammer bearing stud (2.51).
  - (3) Printing hammer stop bracket. Also see Note in 2.54.
  - (4) Lower draw wire rope (2.45).
  - (5) Dashpot vent screw adjustment and check transfer slide for binds (2.50).

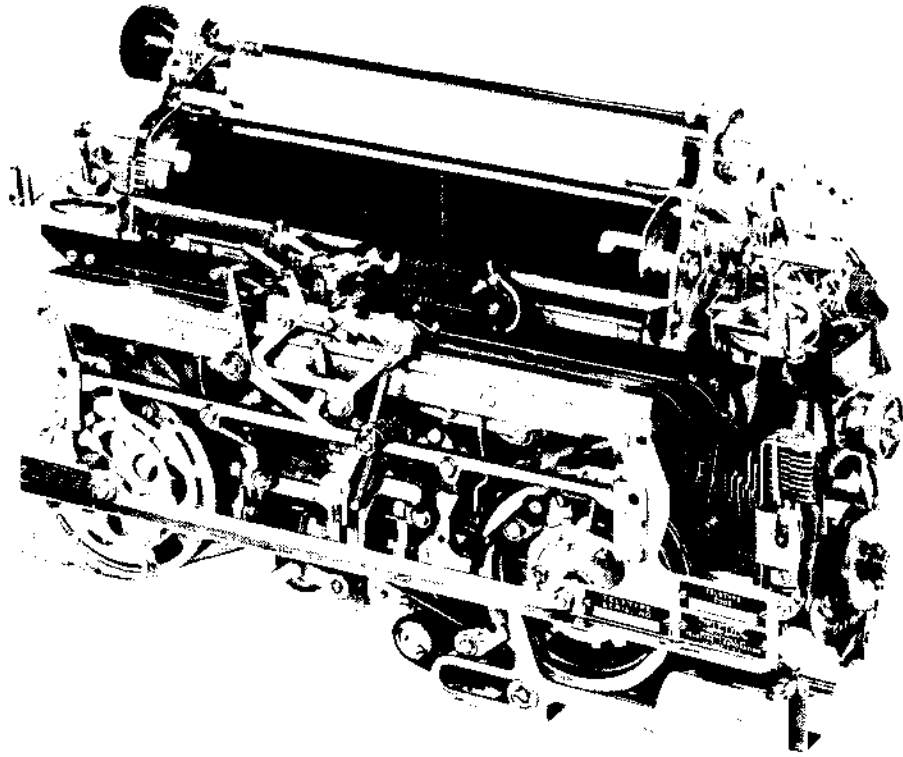

Figure 1 - 35 Typing Unit (Friction Feed)

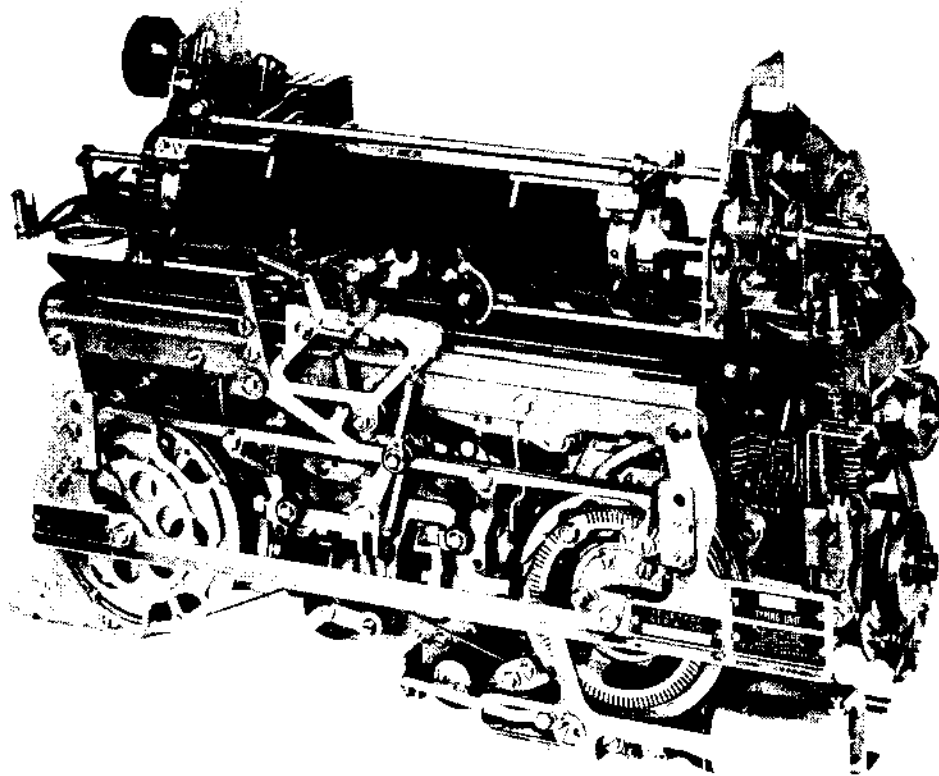

Figure 2 - 35 Typing Unit (Sprocket Feed)

2. BASIC UNITS

2.01 Selector Mechanism

(A) RANGEFINDER KNOB

Requirement

With rangefinder knob turned to either end of rack, and inner teeth of knob and teeth of sector assembly engaged,  $\phi$  mark on scale should be within  $\pm 3$  divisions of scribed line on rangefinder plate.

To Adjust

Loosen knob mounting nut and engage teeth of sector in position that most closely aligns the mark on the plate with the  $\phi$  mark on the knob.

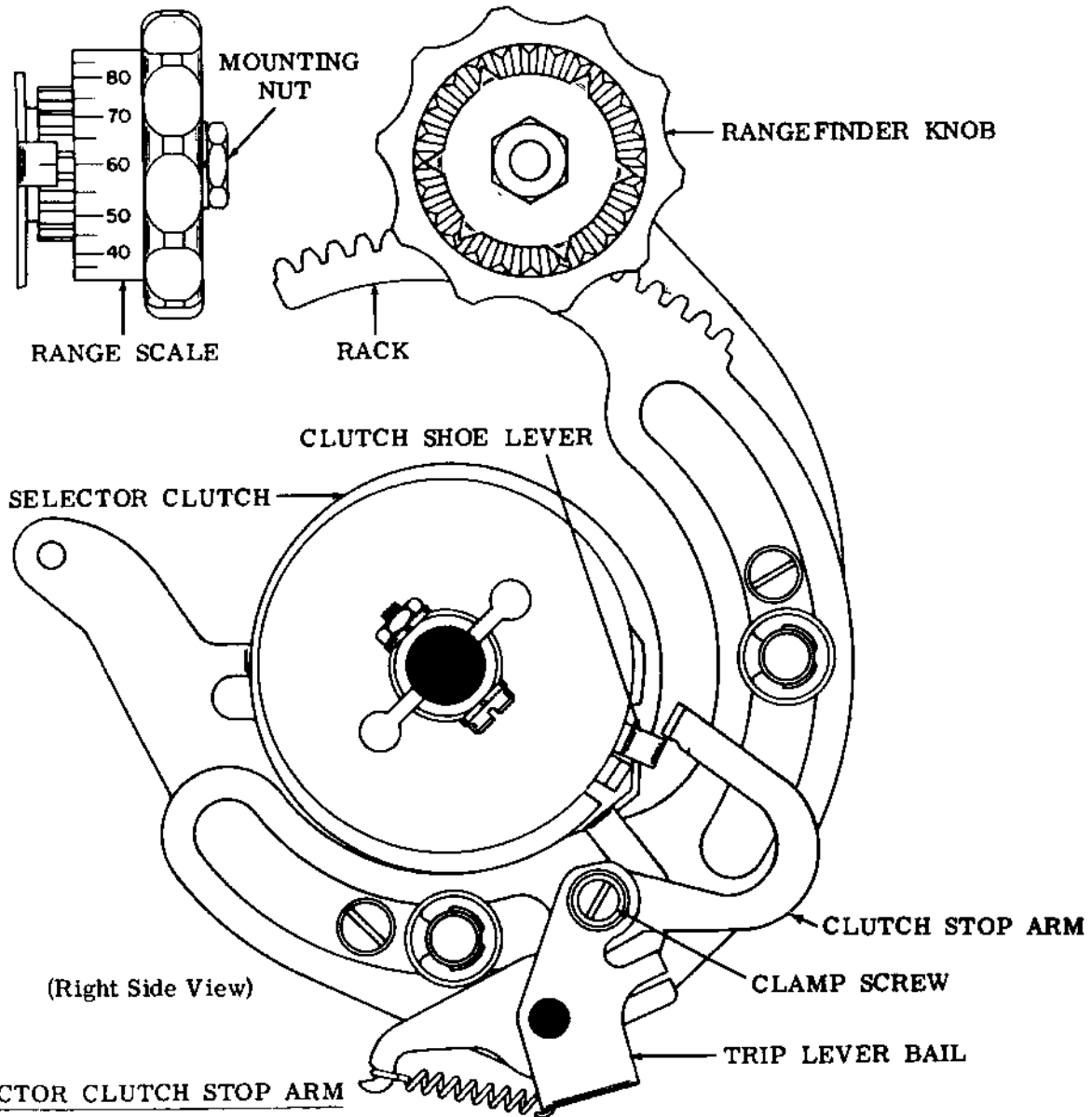

(B) SELECTOR CLUTCH STOP ARM

Requirement

Range scale set at 60. Selector clutch disengaged. Armature in marking position. Clutch stop arm should engage clutch shoe lever by approximately full thickness of clutch stop arm.

To Adjust

Position stop arm on trip lever bail with clamp screw loosened.

2.02 Selector Mechanism (continued)

Note: To facilitate making the following adjustments, remove the rangefinder and selector magnet assemblies. To insure better operation, pull a piece of bond paper between the armature and the pole pieces to remove any oil or foreign matter that may be present. Make certain that no lint or pieces of paper remain between the pole pieces and armature.

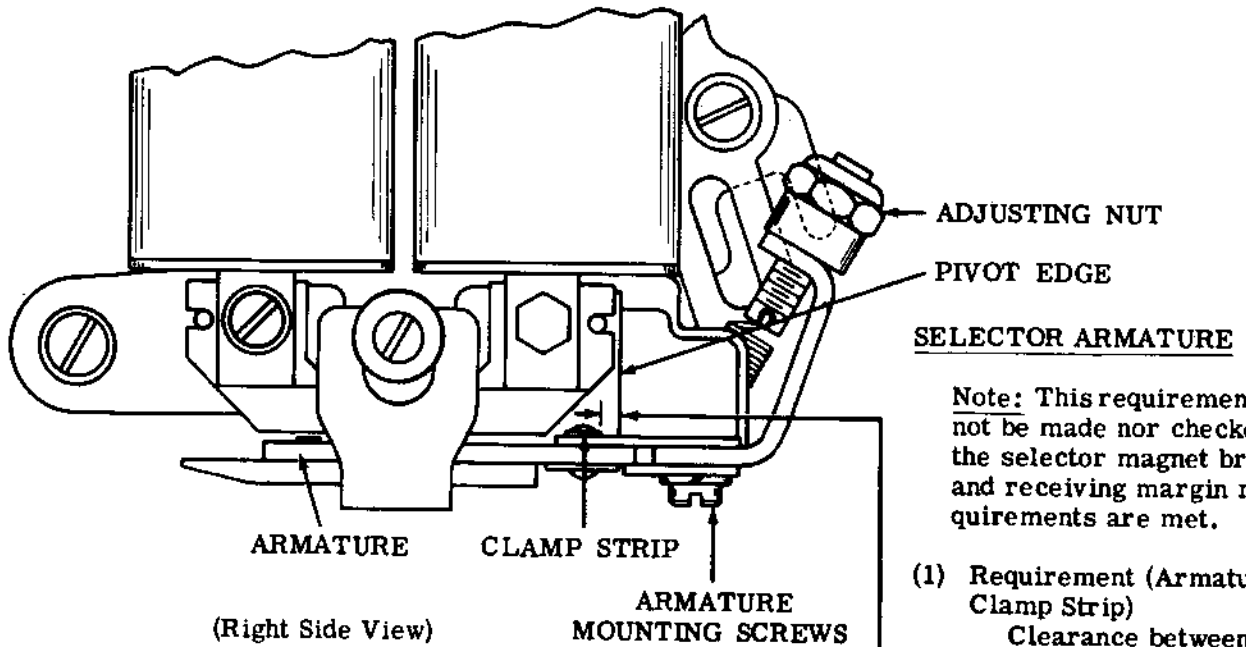

Note: This requirement need not be made nor checked if the selector magnet bracket and receiving margin requirements are met.

- (1) Requirement (Armature Clamp Strip)  
Clearance between armature clamp strip and casting  
— Min 0.010 inch

To Adjust  
Position armature spring adjusting nut to hold armature firmly against pivot edge of casting.

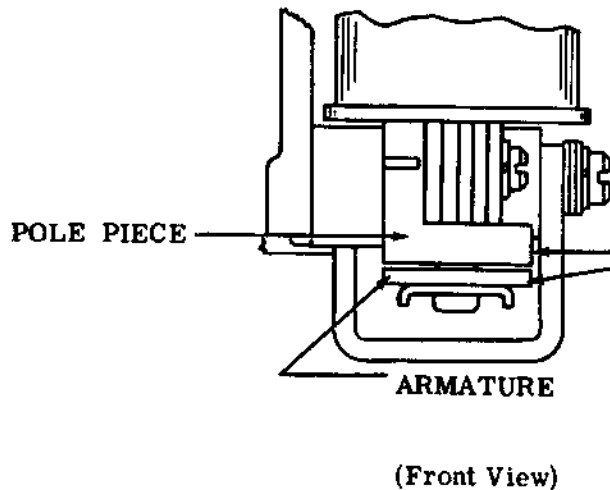

- (2) Requirement (Armature Alignment)  
Outer edge of armature should be flush within  
— Max 0.015 inch  
with outer edge of pole pieces.

To Adjust  
Position armature and backstop with mounting screws loosened.

2.03 Selector Mechanism (continued)

Note: Replace rangefinder and selector magnet assembly.

SELECTOR ARMATURE DOWNSTOP (PRELIMINARY)

Requirement

Magnet de-energized. Locklevers on high part of cam. With armature resting against downstop  
— Min 0.030 inch---Max 0.035 inch  
clearance between end of armature and left edge of left pole piece.

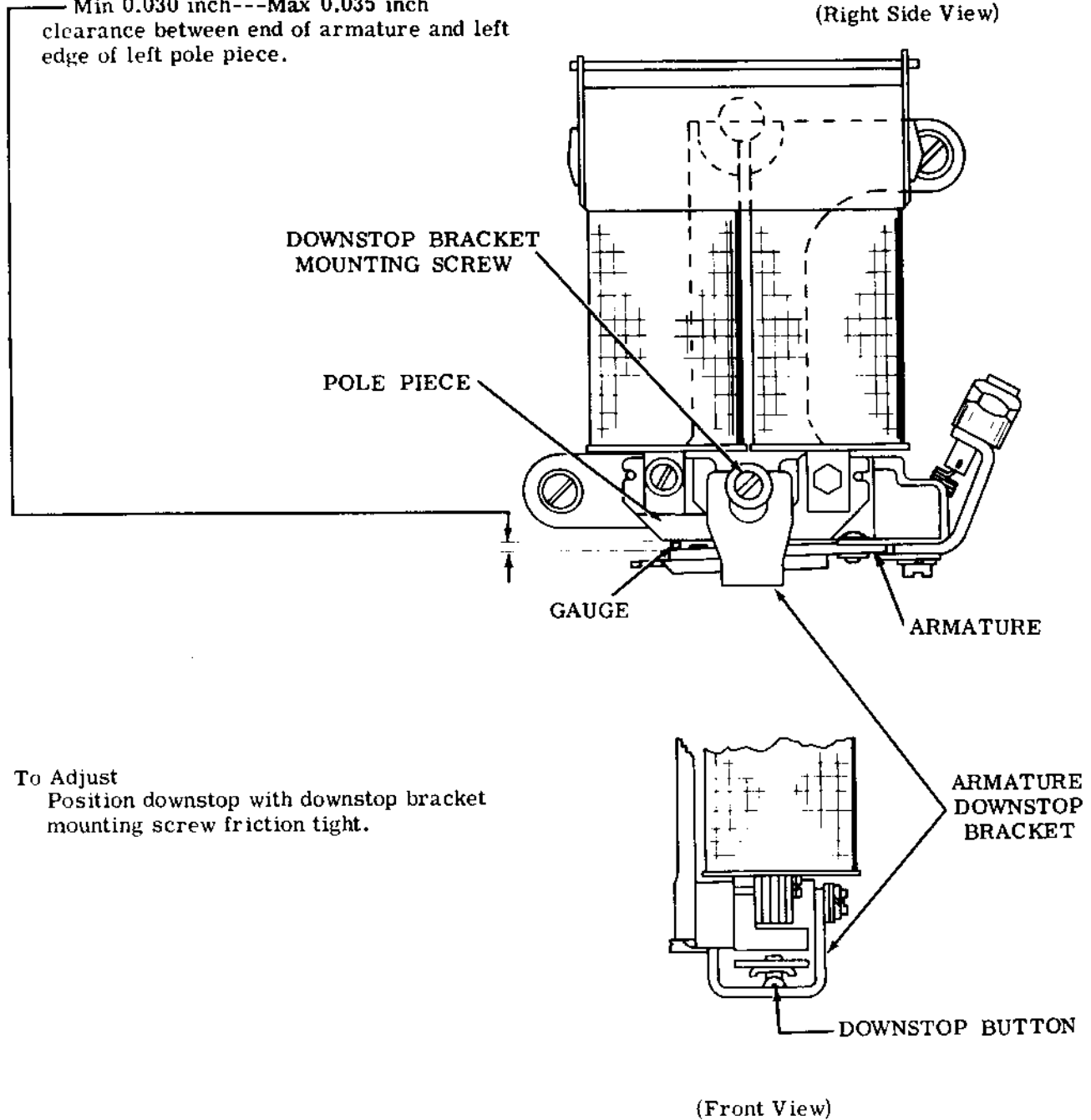

## 2.04 Selector Mechanism (continued)

**SELECTOR ARMATURE SPRING**

(For Units Employing Selector Armature With Single Antifreeze Button Only)

**Requirement (Preliminary)**

With locklevers and start lever on high part of their cams, scale applied as nearly vertical as possible under end of armature extension. It should require the following tensions to move armature to marking position:

0.060 ampere	—	Min 2-1/2 oz	---	Max 3 oz
0.030 ampere	—	Min 1-1/2 oz	---	Max 2 oz
0.500 ampere	—	Min 4-1/2 oz	---	Max 5-1/2 oz

**Note:** This spring can be adjusted for maximum selector performance only when printer is connected to the specific circuit over which it is to operate under service conditions. Since there are several operating speeds and since circuits vary widely, it is impossible to adjust spring for maximum performance at the factory. The foregoing spring tension requirement is given to permit operation prior to measurement of receiving margins. Readjustment made to obtain satisfactory receiving margin should not be disturbed in order to meet requirements of this adjustment.

**To Adjust**

Position adjusting nut.

**Requirement (Final)**

See SELECTOR RECEIVING MARGIN adjustment (2.10).

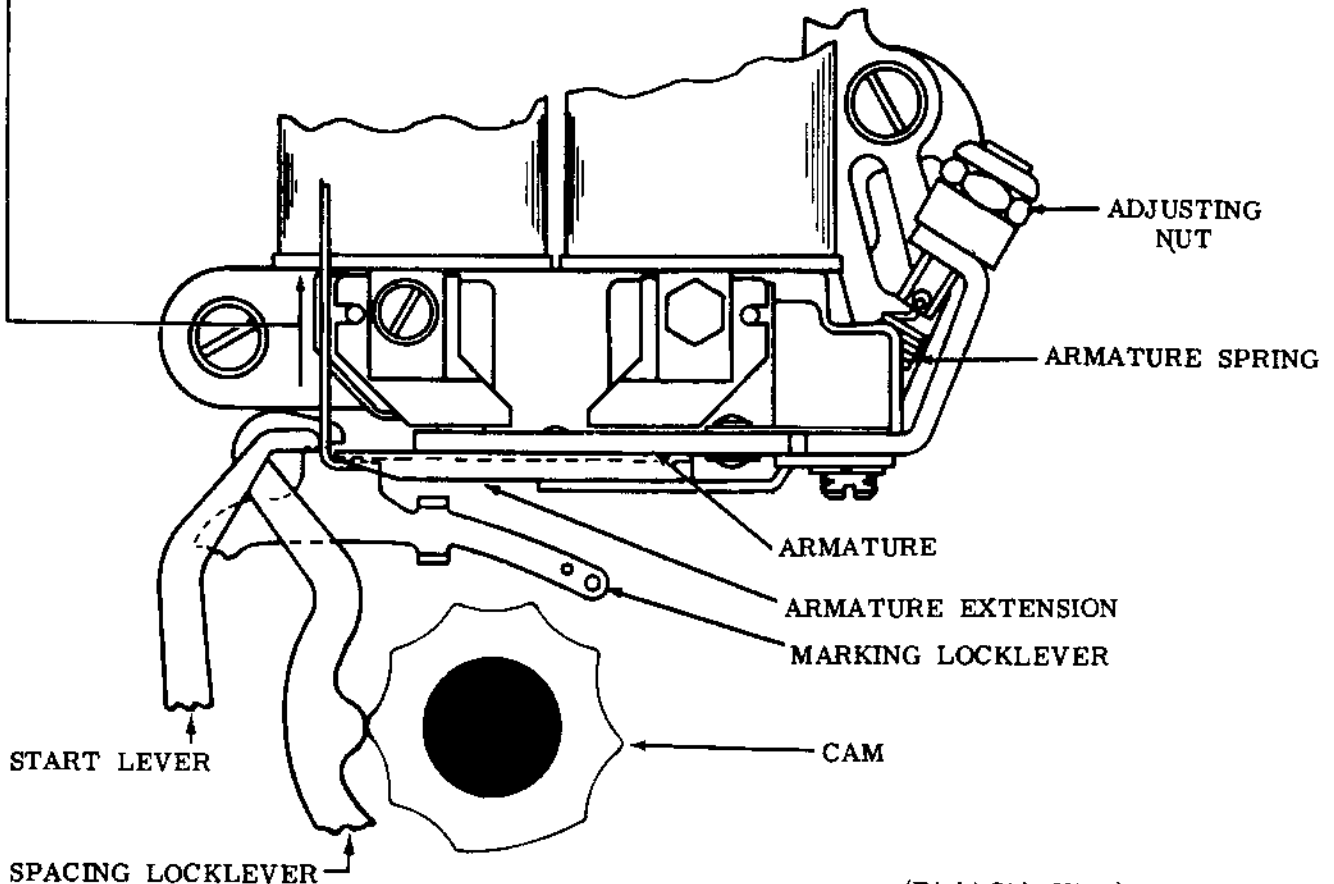

(Right Side View)

2.05 Selector Mechanism (continued)

**SELECTOR ARMATURE SPRING (PRELIMINARY)**

(For Units Employing Selector Armature With Two Antifreeze Buttons Only)

**Requirement**

With locklevers and start lever on high part of their cams, gram scale applied under end of armature extension, it should require approximately the following tensions to move the rear antifreeze button against the magnet core:

- 0.020 ampere --- 14 grams
- 0.030 ampere --- 18 grams
- 0.060 ampere --- 21 grams
- 0.500 ampere --- 28 grams

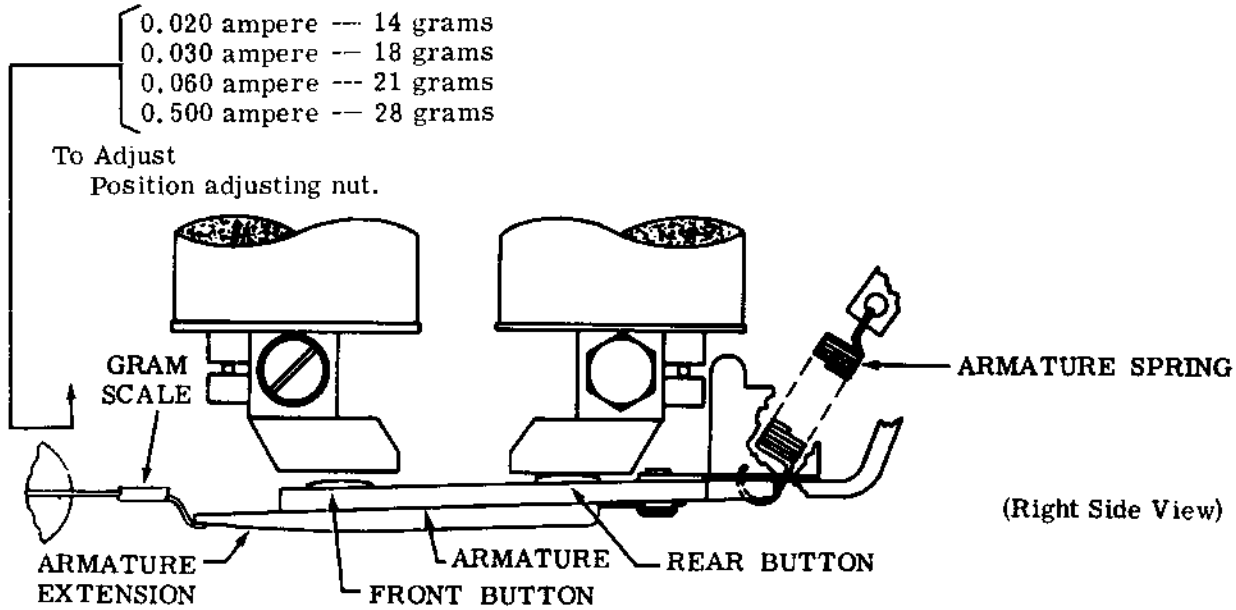

**SELECTOR ARMATURE SPRING (FINAL)**

**Requirement**

When a Distortion Test Set is available, the selector armature spring tension should be refined, if necessary, to obtain satisfactory receiving margins. The front antifreeze button must contact the magnet core when the magnet coils are energized.

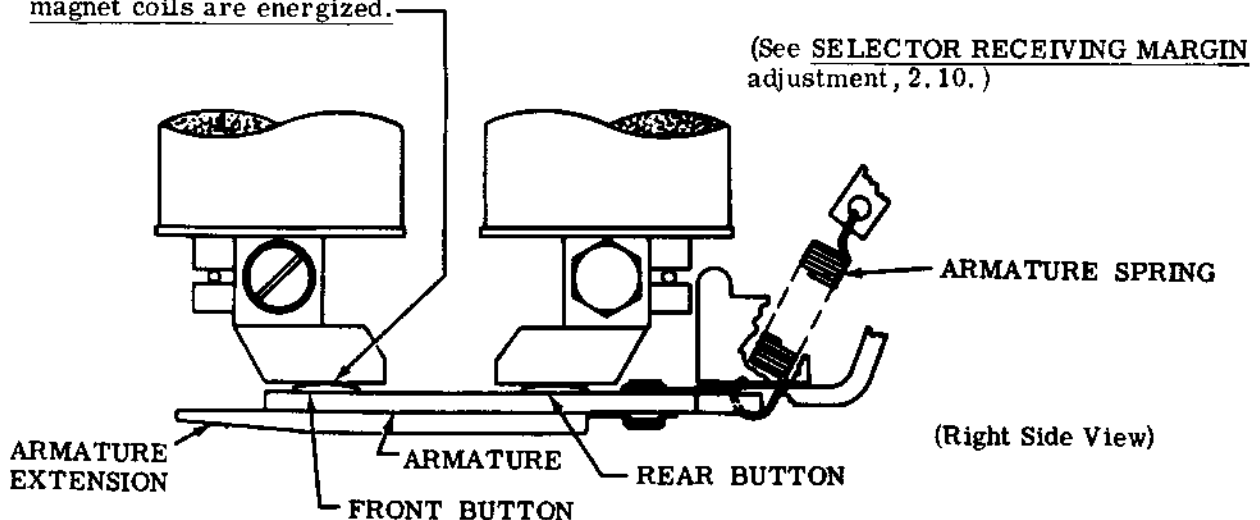

2.06 Selector Mechanism (continued)

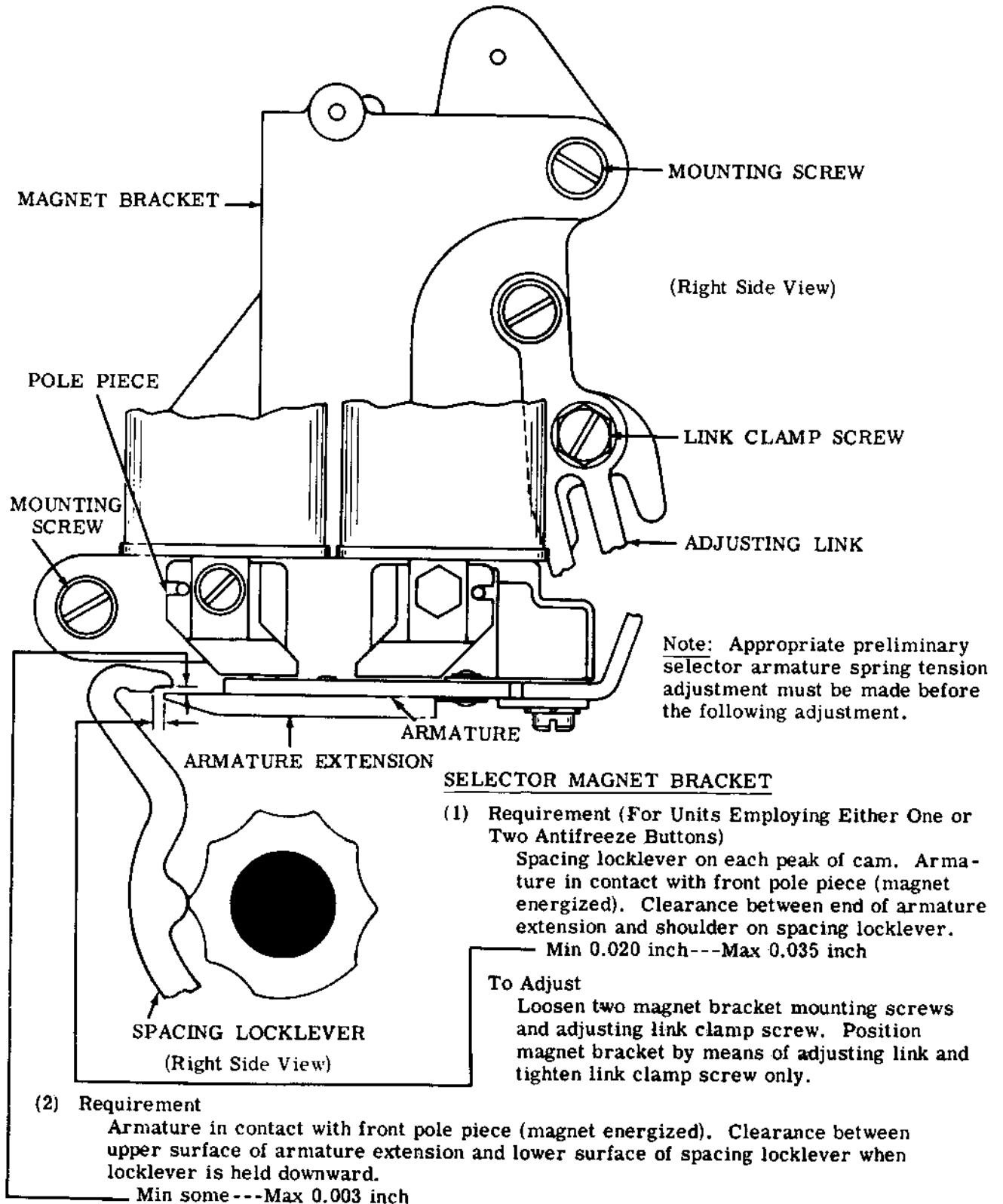



2.07 Selector Mechanism (continued)

SELECTOR MAGNET BRACKET (VERTICAL ADJUSTMENT)

Requirement (For Units Employing Either One or Two Antifreeze Buttons)

—Marking locklever on low of cam. Armature in contact with left pole piece (magnet energized). There should be some clearance between lower surface of armature extension and upper surface of marking locklever. Gauge by eye.

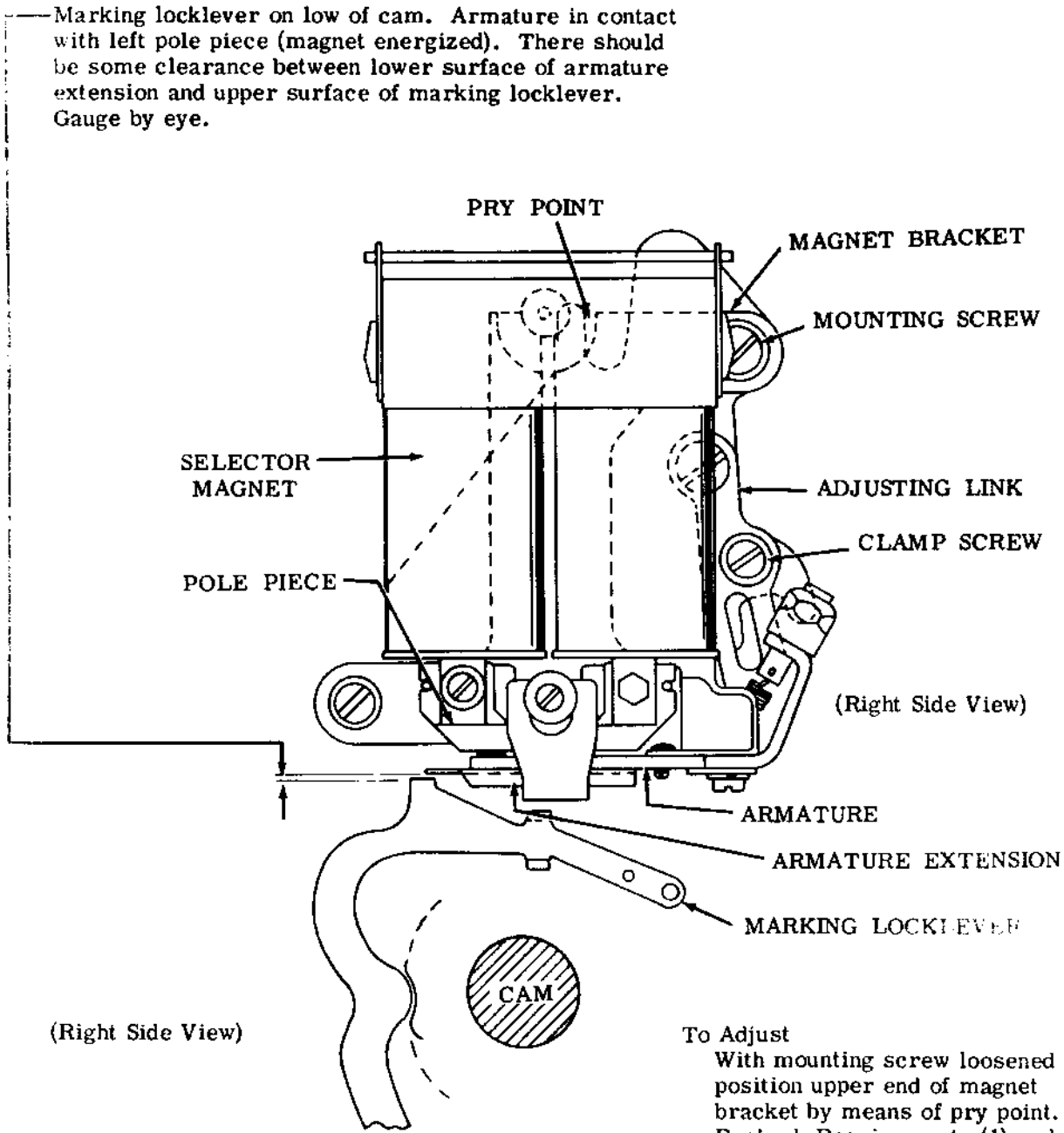

To Adjust  
 With mounting screw loosened position upper end of magnet bracket by means of pry point. Recheck Requirements (1) and (2) of SELECTOR MAGNET BRACKET (2.06).

2.08 Selector Mechanism (continued)

**SELECTOR ARMATURE DOWNSTOP  
(FINAL)**

**Requirement**

Magnet de-energized. Locklevers on low part of their cams

Min 0.005 inch---Max 0.015 inch clearance between top of armature extension and bottom of spacing locklever.

**To Adjust**

Refine **SELECTOR ARMATURE DOWNSTOP (PRELIMINARY) (2.03)**.

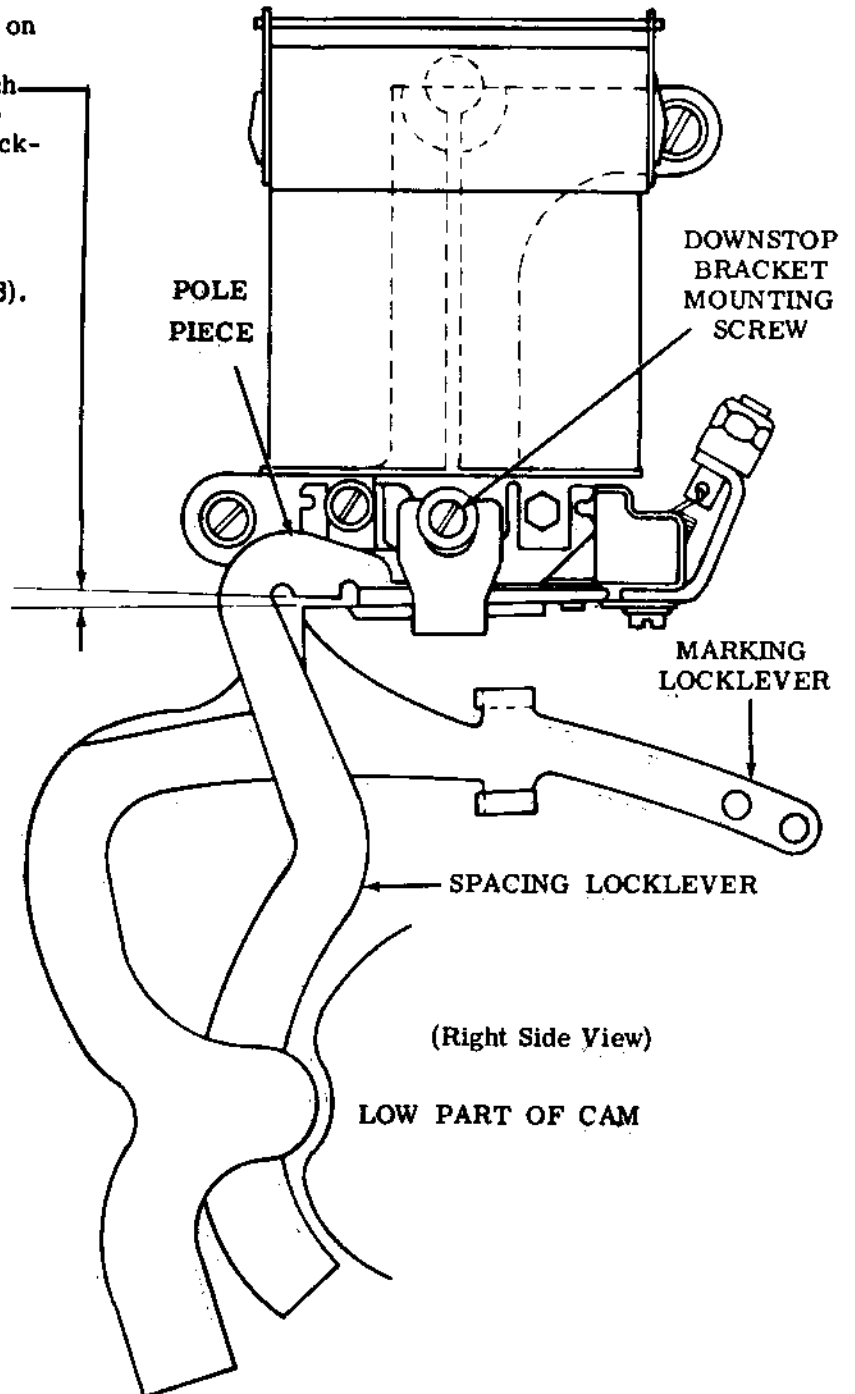

2.09 Selector Mechanism (continued)

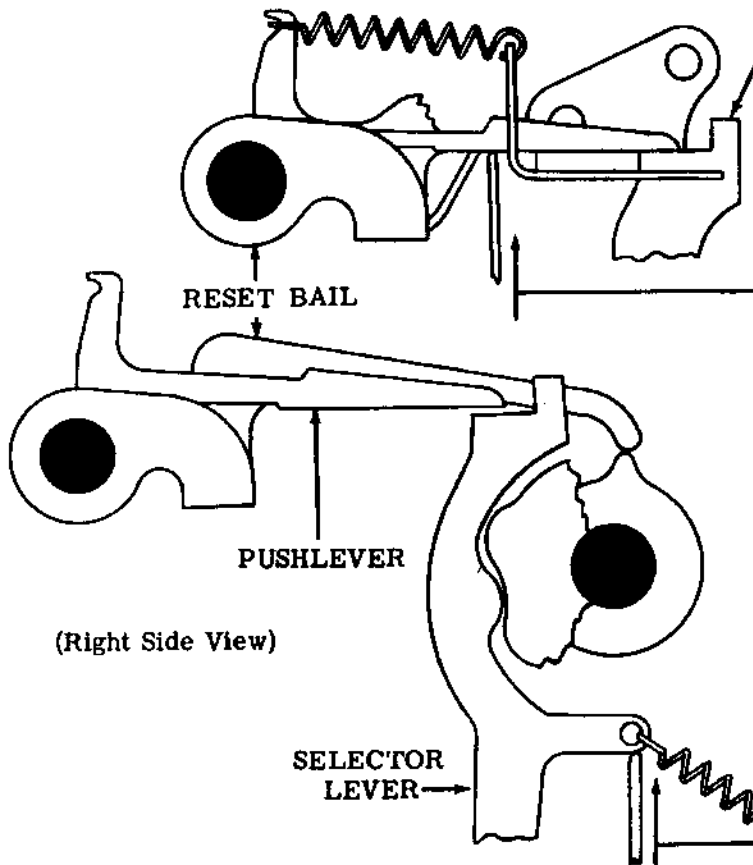

SELECTOR PUSHLEVER SPRING

Requirement  
 Pushlever in spacing position  
 — Min 3/4 oz---Max 1-1/2 oz  
 to move pushlevers from selector  
 levers on all except first pushlever  
 in sequence of selection. It should  
 require  
 — Min 2 oz---Max 3 oz  
 to move this pushlever from its  
 selector lever. This spring is  
 copper color.

SELECTOR LEVER SPRING

Requirement  
 Typing unit upside down.  
 Reset bail on peak of its cam.  
 — Min 1-1/2 oz---Max 3 oz  
 to start each lever moving.  
 If necessary, unhook start lever  
 spring to check selector lever  
 springs near the start lever spring.

SELECTOR CLUTCH DRUM

Requirement  
 Clutch latched in stop position. Cam-  
 clutch assembly should have some endplay  
 — Max 0.010 inch

To Adjust  
 Position the clutch drum on main shaft  
 with mounting screw loosened. Tighten screw.

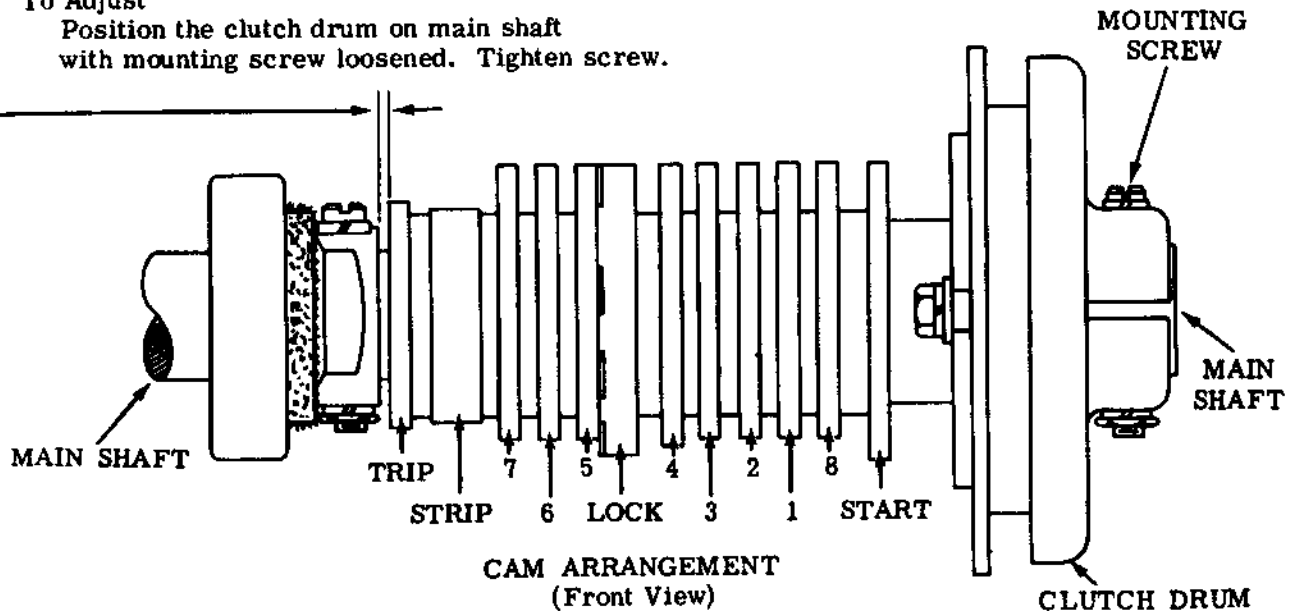

2.10 Selector Mechanism (continued)

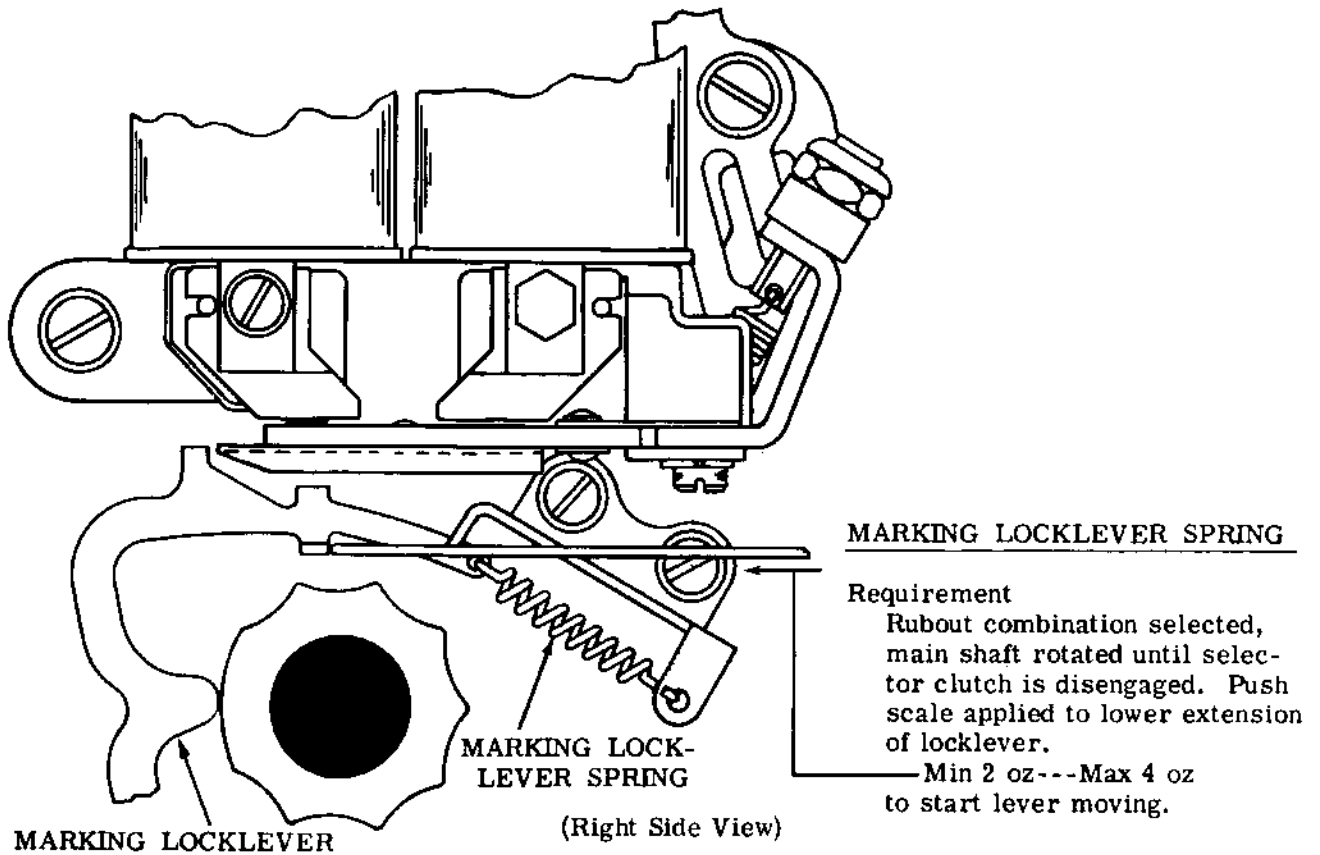

SELECTOR RECEIVING MARGIN

- (1) Requirement (For Units Employing Armature With One Antifreeze Button)  
 When a signal Distortion Test Set is used for determining the receiving margins of the selector, and where the condition of the components is equivalent to that of new equipment, the range and distortion tolerances below should be met.
- (2) Requirement (For Units Employing Armature With Two Antifreeze Buttons)  
 When a Distortion Test Set is available, the selector armature spring tension should be refined, if necessary, to obtain satisfactory receiving margins. The front antifreeze button must contact the magnet core when the magnet coils are energized.

To Adjust

Refine the SELECTOR ARMATURE SPRING adjustments (2.04, 2.05).

Selector Receiving Margin Minimum Requirements

<u>Current</u>	<u>Speed in WPM</u>	<u>Points Range With Zero Distortion</u>	<u>Percentage of Marking and Spacing Bias</u>	<u>End Distortion Tolerated With Scale at Bias Optimum Setting</u>
0.500 Amp (Windings Parallel)	100	72	38	35
0.060 Amp (Windings Parallel) (For LP821 Only)	100	72	35	33

2.11 Selector Mechanism (continued)

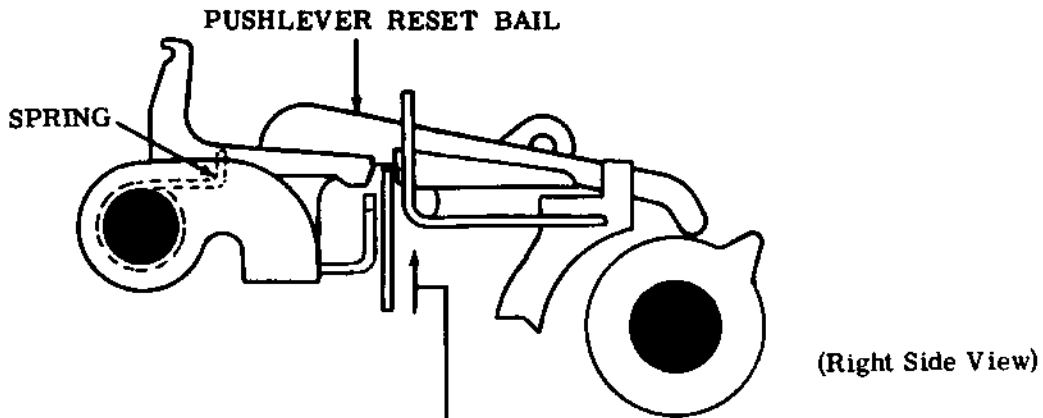

PUSHLEVER RESET BAIL SPRING

Requirement  
Pushlever reset bail on low part of cam.  
32 oz scale applied to reset bail.  
— Min 4 oz ---Max 8 oz  
to move bail from cam.

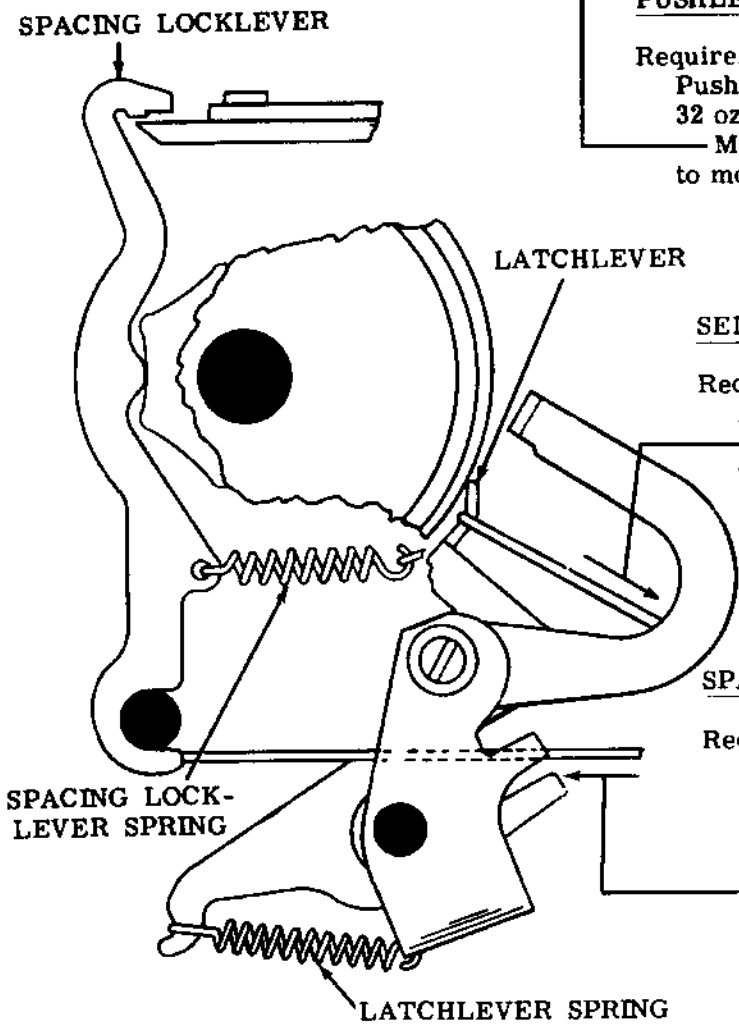

SELECTOR CLUTCH LATCHLEVER SPRING

Requirement  
Latch resting on low part of the clutch disc.  
— Min 2 oz ---Max 3-1/2 oz  
to start latch moving.

SPACING LOCKLEVER SPRING

Requirement  
Selector armature released. Spacing  
locklever on low part of its cam. Spring  
scale applied to lower end of spacing  
locklever.  
— Min 3 oz ---Max 6 oz  
to move spacing locklever from its pivot  
shaft.

2.12 Selector Mechanism (continued)

**START LEVER SPRING**

**Requirement**

Latchlever spring unhooked. Stop arm bail in indent of its cam. Range scale set at 60.

Min 2-1/2 oz---Max 4-1/2 oz to start stop arm moving.

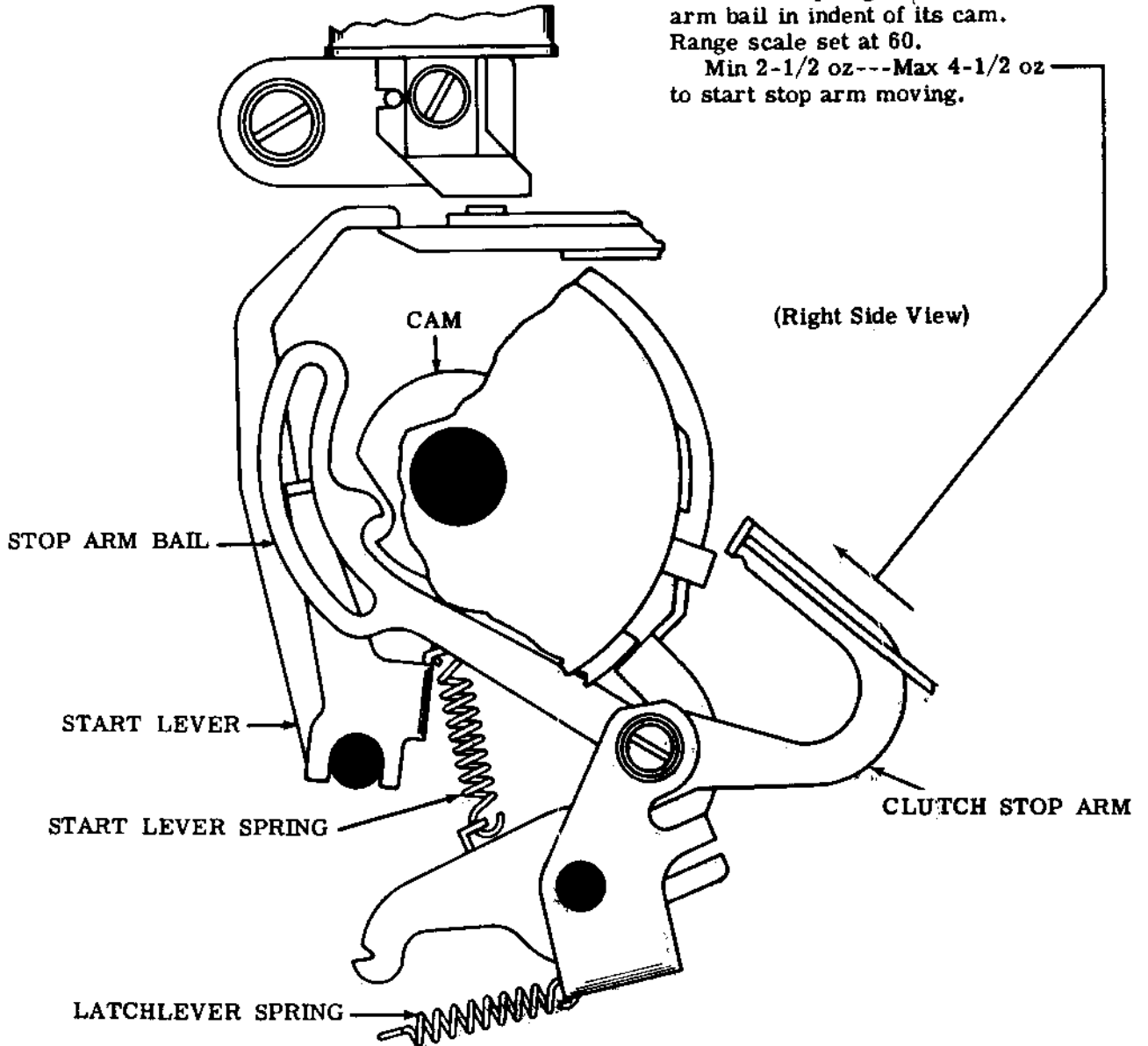

2.13 Codebar Mechanism

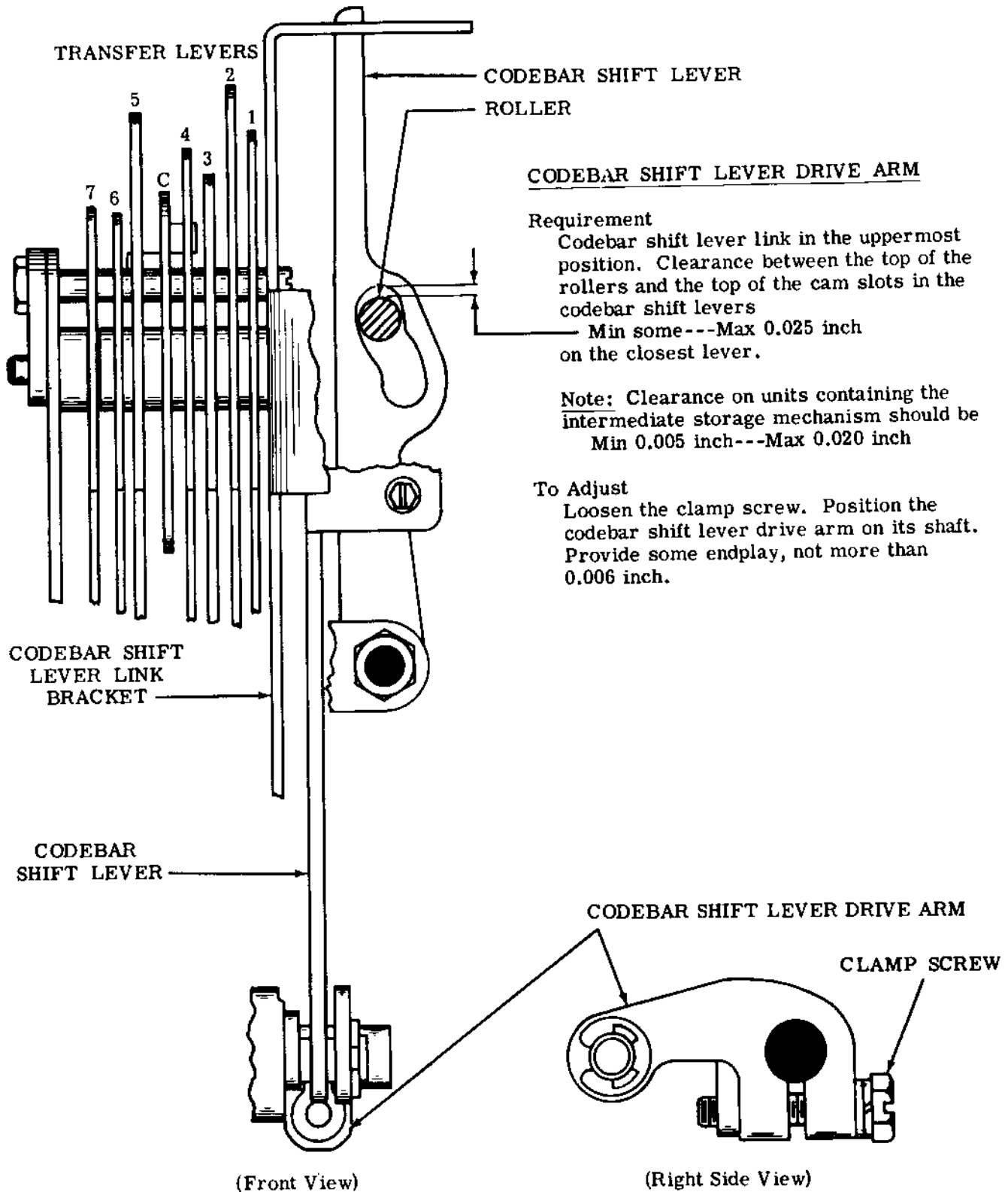

2.14 Codebar Mechanism (continued)

COMMON TRANSFER LEVER SPRING

Requirement

Transfer lever in spacing position. Scale applied near upper end of common transfer lever.

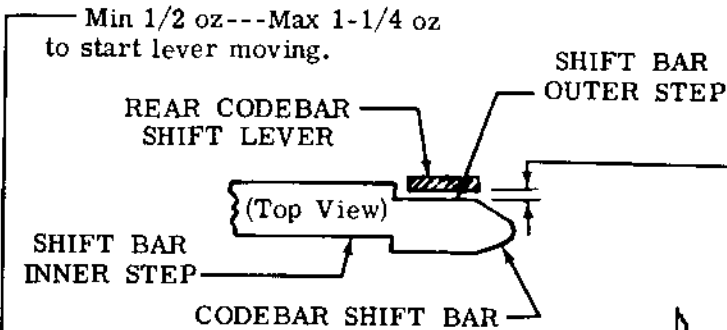

TRANSFER LEVER ECCENTRIC

Requirement

Pushlevers positioned for rubout. Selector clutch disengaged. Codebar shift lever link in uppermost position, clearance between rear codebar shift lever and rear edge of shift bar farthest from rear codebar shift lever  
Min 0.010 inch---Max 0.025 inch

Note 1: On units having the intermediate storage mechanism, the clearance between the rear shift lever and the rear edge of the shift bar should be  
Min 0.010 inch---Max 0.025 inch when play of shift bar is taken up for maximum clearance.

To Adjust

Rotate eccentric bushing with clamp screw loosened. High part of eccentric should be above horizontal center line.

Note 2: One or more codebar shift bars can touch codebar shift levers.

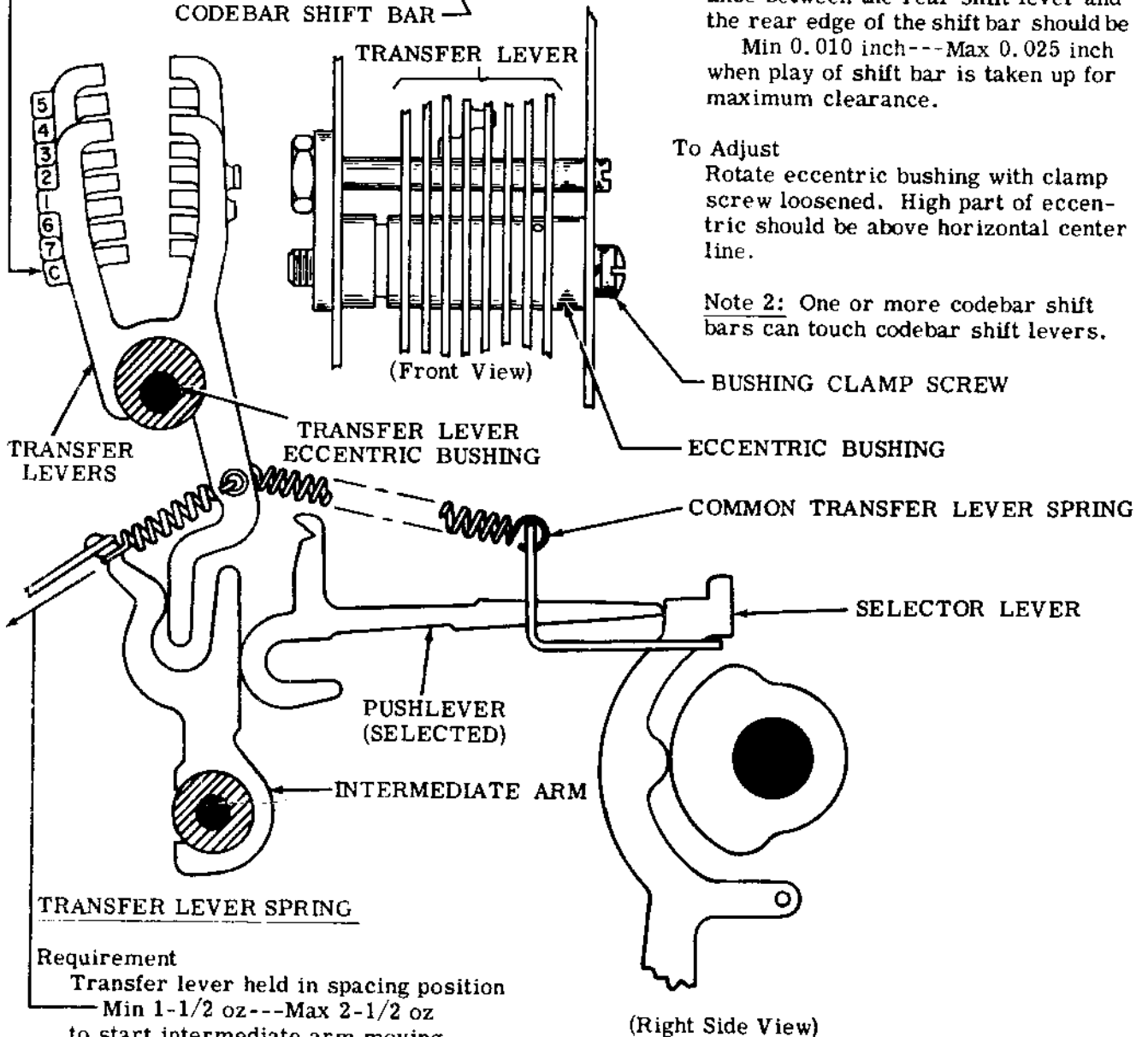



2.15 Codebar and Selector Mechanisms (continued)

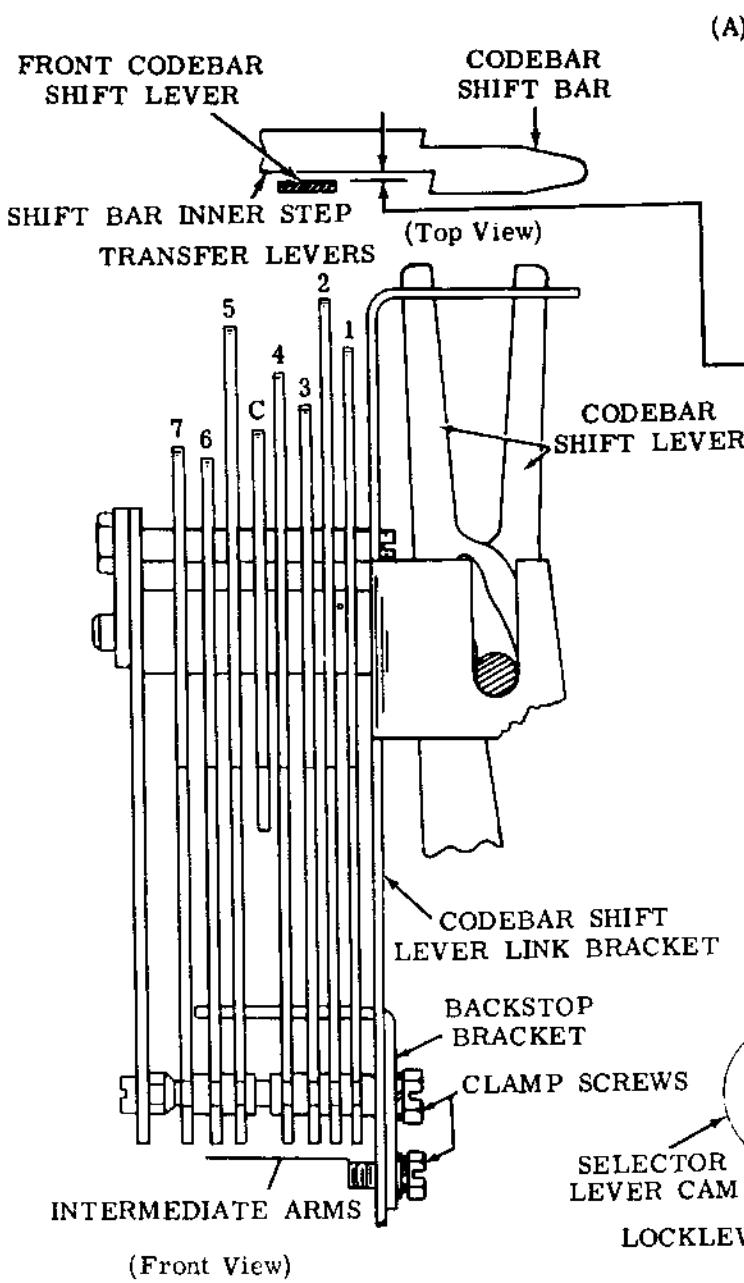

(A) INTERMEDIATE ARM BACKSTOP BRACKET

Requirement

Pushlevers not selected. All codebar shift bars to the right. Selector clutch disengaged. Codebar shift lever link in lowermost position. Clearance between front codebar shift lever and the front edge of the inner step of the codebar shift bar farthest from front codebar shift lever

Min 0.010 inch--Max 0.025 inch when play in parts is taken up for maximum clearance.

To Adjust

Position backstop bracket with its two clamp screws loosened.

Note: Number 7 codebar shift bar does not have to meet the maximum requirement until the SHIFT SELECTOR ARM BELLCRANK (2.43) adjustment has been made.

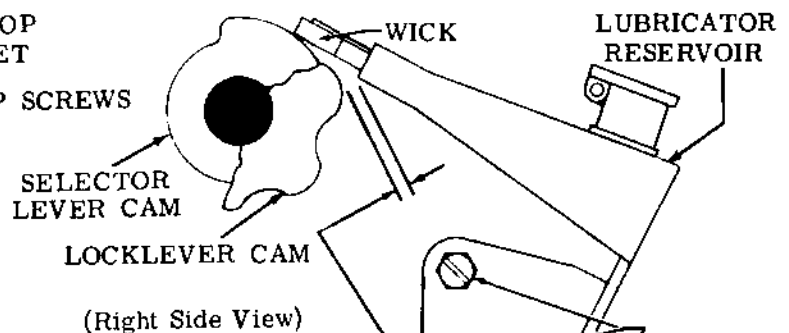
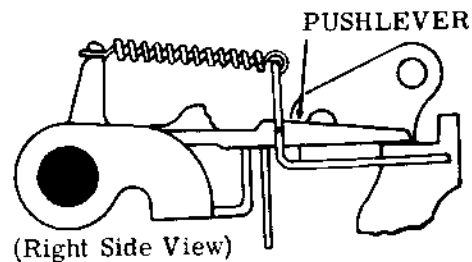

(B) SELECTOR CAM LUBRICATOR

Requirement

The lubricator tube should clear the high part of the locklever cam  
Min 0.020 inch

The high part of the selector lever cams should touch the lubricator wick, but should not raise it more than 1/32 inch.

Note: There should be some clearance between the marking locklever spring and the reservoir.

To Adjust

Position the lubricator bracket with its mounting screws loosened.

2.16 Codebar Mechanism (continued)

CODEBAR SHIFT LEVER

Requirement

Motion of front and rear codebar shift levers should be equalized with respect to codebar travel.

(1) To Check (Front)

Select blank combination and rotate main shaft until codebar shift lever link reaches highest travel. Take up play for maximum clearance. Clearance between front codebar shift lever and shoulder on nearest codebar shift bar

Min 0.002 inch--Max 0.025 inch

(2) To Check (Rear)

Select rubout combination. Check clearance between rear codebar shift lever and shoulder on nearest codebar shift bar in same way.

Min 0.002 inch--Max 0.025 inch

Note: The clearance on units containing the intermediate storage mechanism should be

Min 0.002 inch--Max 0.012 inch

To Adjust

Position adjusting plates (front and rear) with clamp screws loosened.

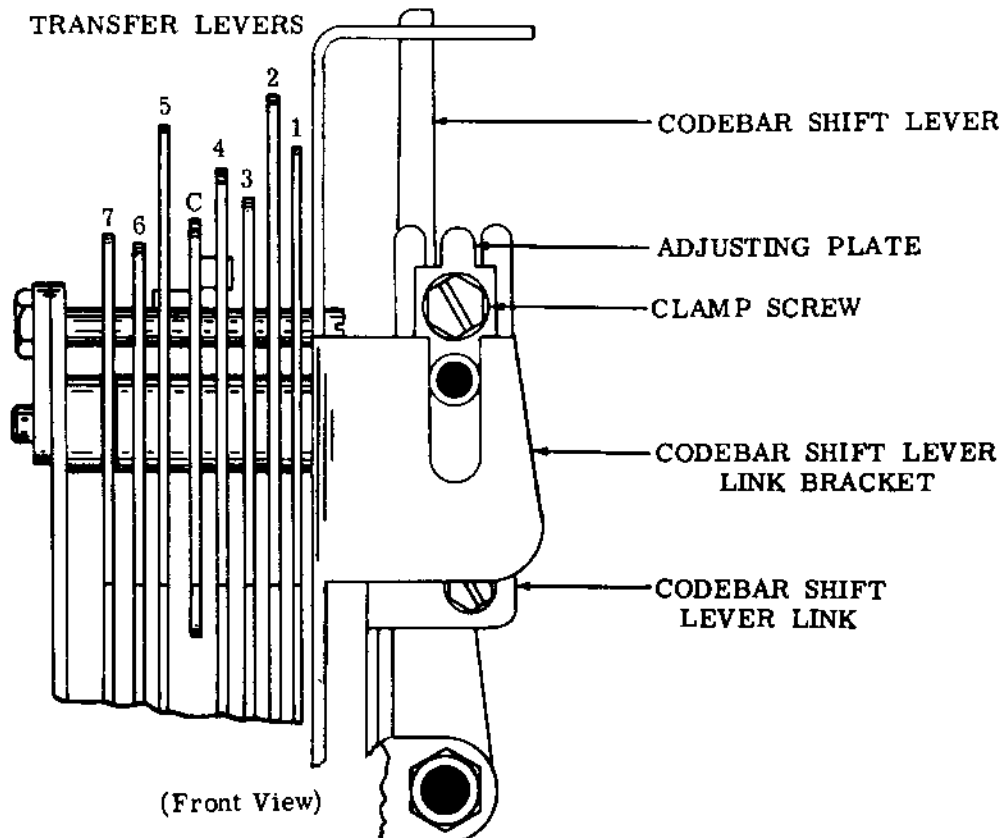
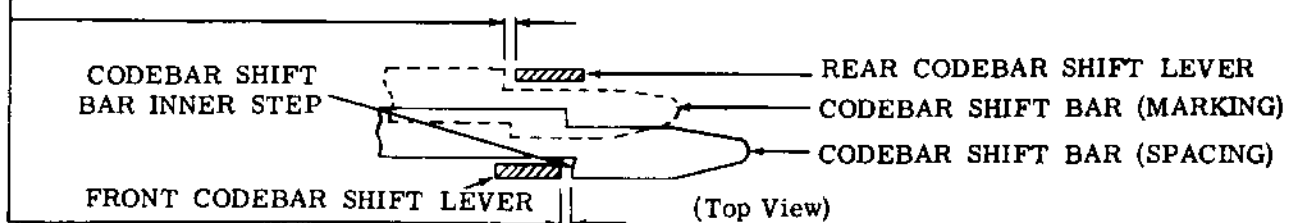

2.17 Codebar Mechanism (continued)

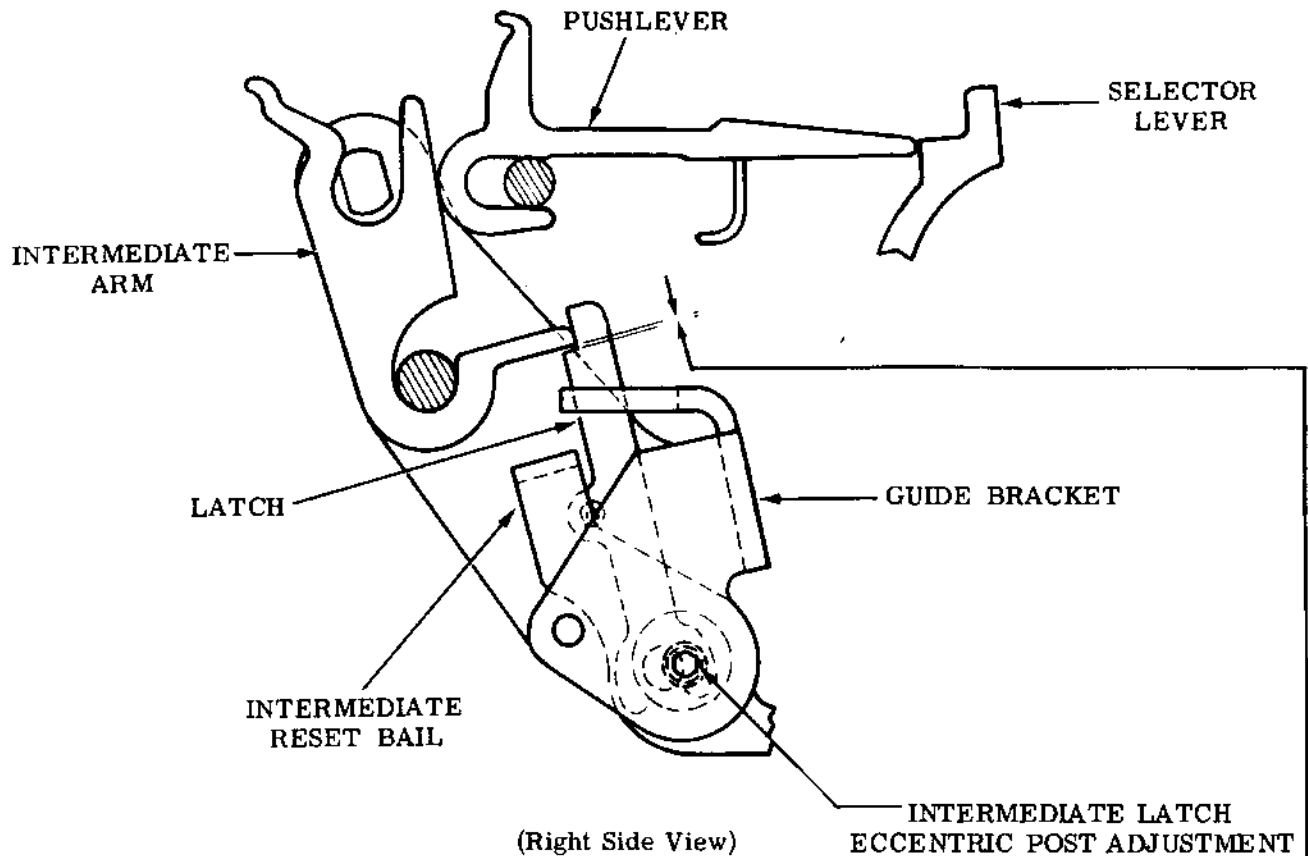

INTERMEDIATE LATCH ECCENTRIC

Note: This adjustment applies to units containing the intermediate storage mechanism.

**Requirement**

Pushlevers positioned for rubout. Selector clutch disengaged. Clearance between the top of latch surface on the latch and the bottom of the intermediate arm having the least clearance.

Min 0.002 inch---Max 0.006 inch

Check all latches.

**To Adjust**

Rotate the latch eccentric post to meet the requirement keeping the high part of the eccentric to the front.

## 2.18 Codebar Mechanism (continued)

(A) INTERMEDIATE RESET LEVER SPRING

Note: This adjustment applies to units containing the intermediate storage mechanism.

**Requirement**

With the intermediate reset lever in its unoperated position and the spring removed from the lever

Min 1 oz---Max 2 oz \_\_\_\_\_  
to stretch the spring to its installed length. Replace the spring.

(B) INTERMEDIATE RESET BAIL SPRING

Note: This adjustment applies to units containing the intermediate storage mechanism.

**Requirement**

With all pushlevers in the marking condition and the latches in a latched position, push against the reset bail at the spring hole

Min 5 oz---Max 7 oz \_\_\_\_\_  
to move the latches out of engagement of the intermediate arms.

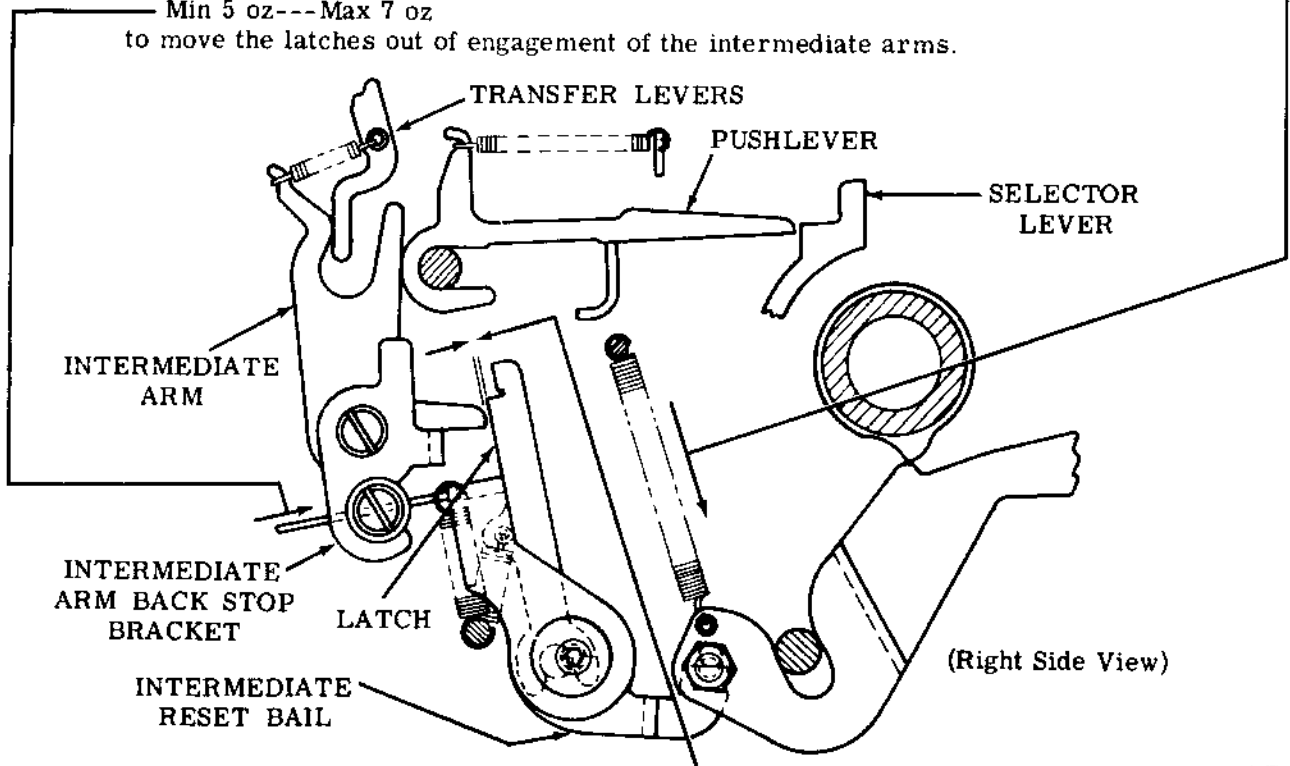
(C) INTERMEDIATE RESET BAIL ECCENTRIC

Note 1: This adjustment applies to units containing the intermediate storage mechanism (for applicable unit).

**Requirement**

With the intermediate reset lever on the high part of its cam. Clearance between the latch and the intermediate arm should be

Min 0.010 inch \_\_\_\_\_  
with the high part of the eccentric to the rear.

**To Adjust**

Rotate eccentric to meet requirement.

Note 2: The codebar positioning mechanism is assembled at the factory and at this time the guide bracket is biased to the rear by means of the play in the body holes. If this assembly is removed from the printer, it will be necessary to bias the guide bracket to the rear during reassembly.

2.19 Main Shaft and Trip Shaft Mechanisms

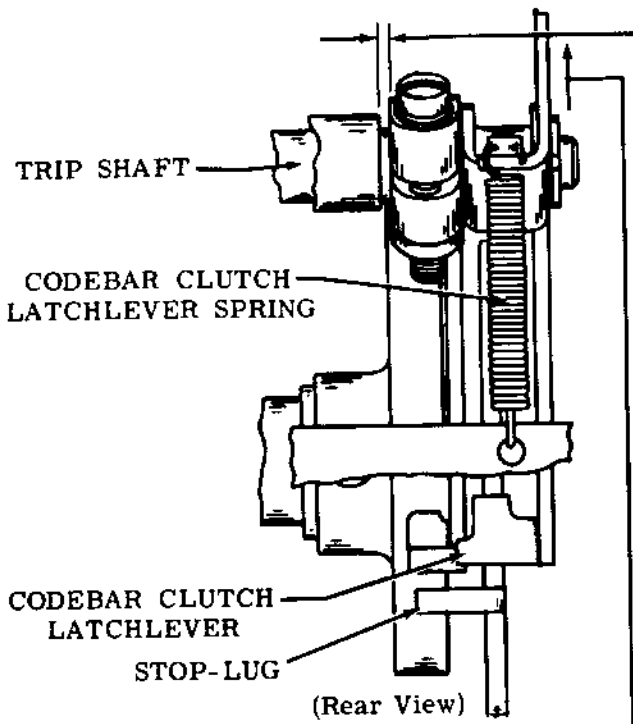

(Rear View)

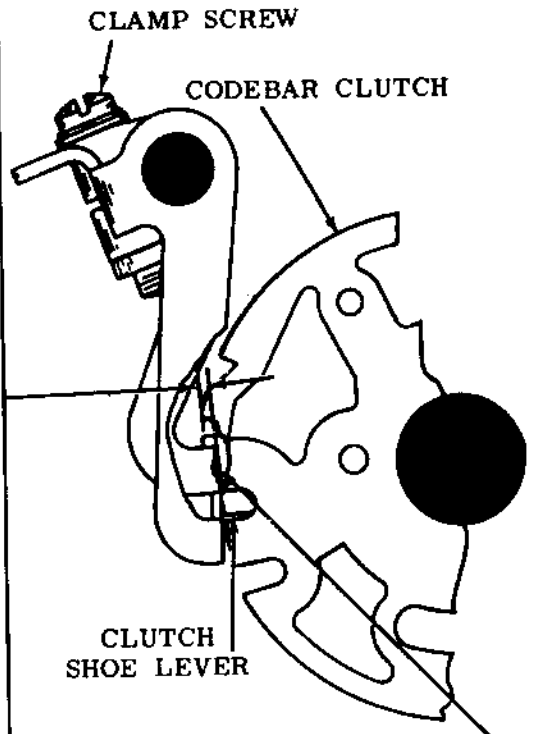

(Left Side View)

CLUTCH LATCHLEVER SPRING  
(EXCEPT SELECTOR)

**Requirement**  
Clutch latchlever on high surface of clutch disc  
Min 5 oz---Max 7-1/4 oz  
to move latchlever from lug.  
This requirement applies to codebar clutch, function clutch, spacing clutch, line feed clutch, and typebox clutch.

CODEBAR CLUTCH TRIP LEVER

**Requirement**  
Selector clutch and codebar clutch disengaged.  
Codebar clutch trip lever should engage clutch shoe lever by full thickness of shoe lever and have some endplay  
---Max. 0.006 inch

To Adjust  
Position trip lever on its shaft with clamp screw loosened.

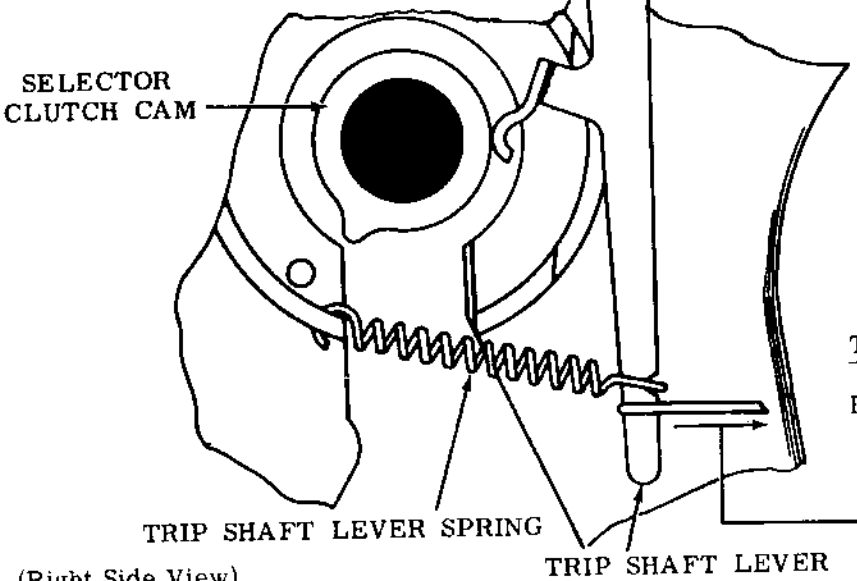

TRIP SHAFT LEVER SPRING

(Right Side View)

TRIP SHAFT LEVER SPRING

**Requirement**  
Trip shaft lever on low part of cam. Codebar clutch engaged.  
Rotate 1/4 turn.  
---Min 1 oz---Max 2 oz  
to start lever moving.

TRIP SHAFT LEVER

2.20 Main Shaft and Trip Shaft Mechanisms (continued)

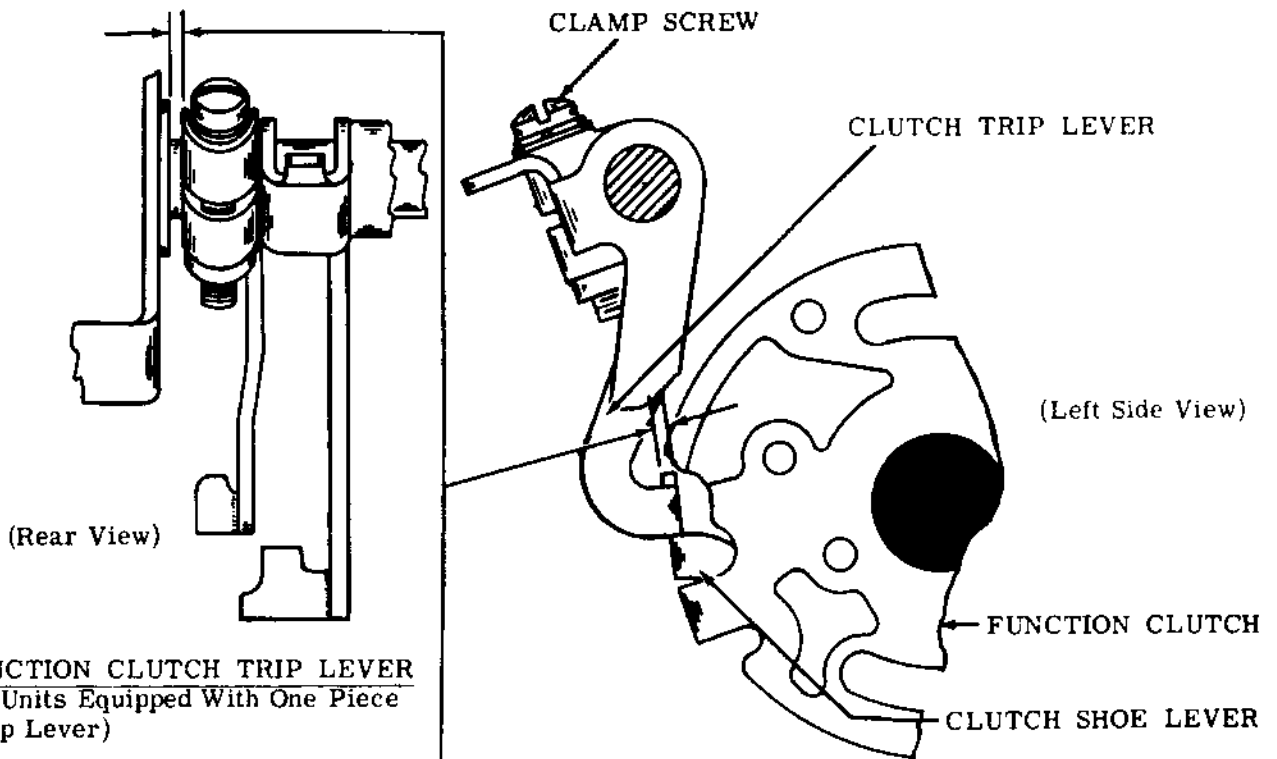

**FUNCTION CLUTCH TRIP LEVER**  
(On Units Equipped With One Piece Trip Lever)

**Requirement**

Codebar clutch and function clutch disengaged. Function clutch trip lever should engage clutch shoe lever by full thickness of shoe lever. (Check at lug with least bite on two stop clutches.)

**To Adjust**

Position trip lever on its shaft with clamp screw loosened, letting shaft have endplay  
Min some---Max 0.006 inch

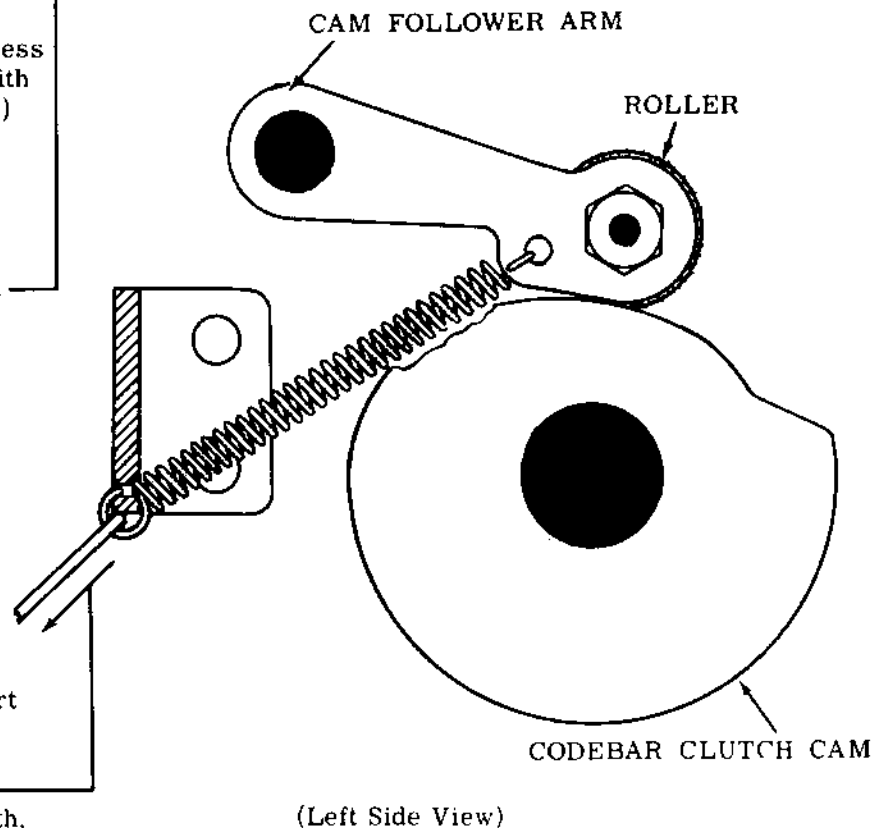

**CODEBAR CLUTCH CAM FOLLOWER SPRING**

**Requirement**

Cam follower roller on low part of cam. The spring unhooked from spring bracket.

Min 20 oz---Max 24 oz  
to pull spring to installed length.

2.21 Main Shaft and Trip Shaft Mechanisms (continued)

(A) FUNCTION CLUTCH TRIP LEVER TRIP ARM  
(On Units Equipped With Adjustable Backstop)

Requirement

Codebar clutch and function clutch disengaged. Clearance between edge of bail of function clutch trip lever and projection on trip lever trip arm.

Min 0.040 inch---Max 0.050 inch

When making this adjustment, position the trip lever trip arm so that the trip shaft has some endplay

Min some---Max 0.006 inch

To Adjust

Position trip arm on trip shaft with its clamp screw loosened.

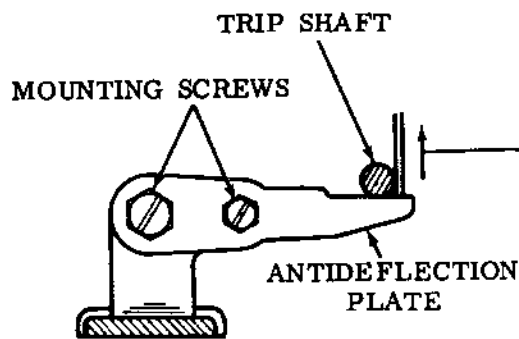
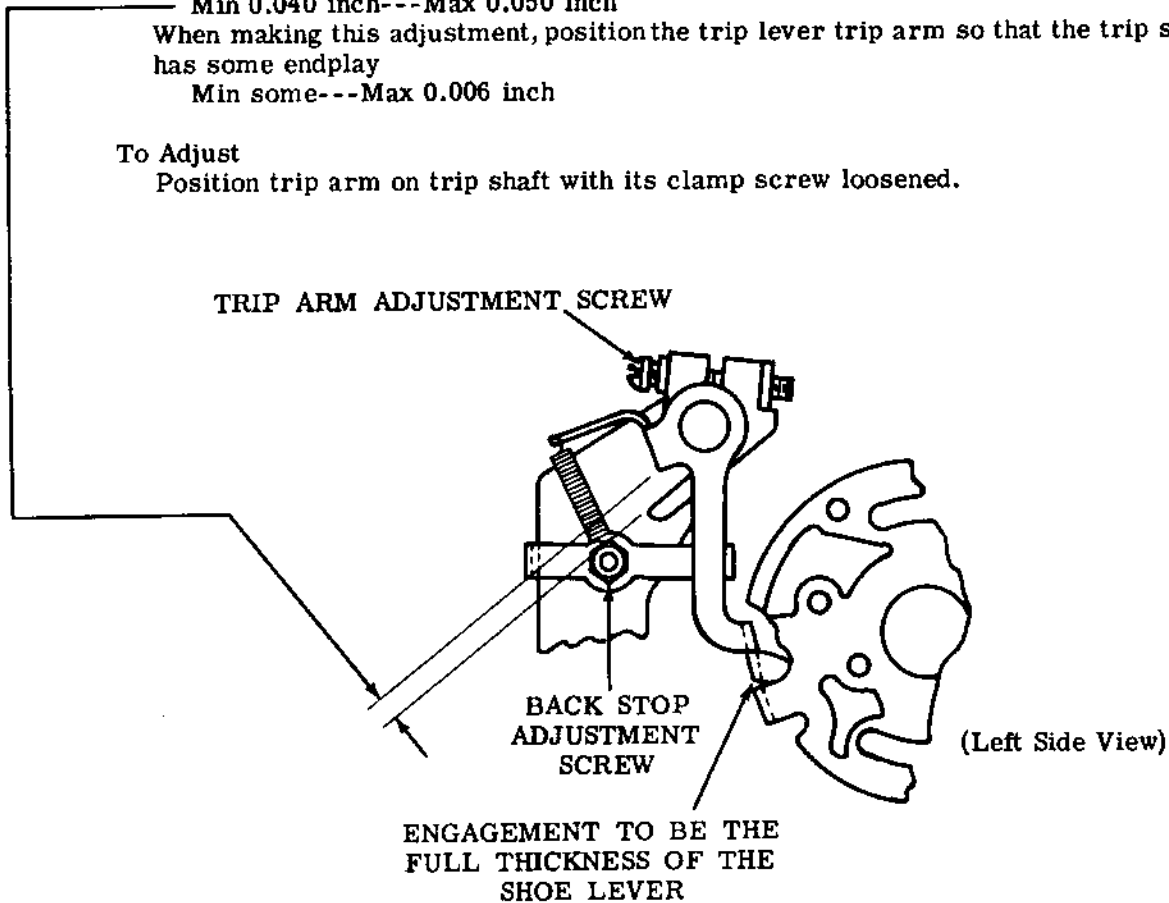

(Left Side View, Upside Down)

(B) ANTIDEFLECTION PLATE

Requirement

With typing unit upside down and function, spacing, line feed, and type-box clutches disengaged and latched

Min 1 lb---Max 5 lb  
to pull trip shaft away from anti-deflection plate.

To Adjust

Position plate with mounting screws loosened.

2.22 Main Shaft and Trip Shaft Mechanisms (continued)

(A) CLUTCH TRIP SHAFT SET COLLARS

- (1) Requirement  
 Spacing cutout lever should have side play  
 Min some---Max 0.008 inch

To Adjust  
 Position spacing cutout lever set collar.

- (2) Requirement

Approximate alignment of right end of stop extensions on trip lever and shoe lever.

To Adjust  
 Position line feed clutch trip lever set collar.

- (3) Requirement

Line feed clutch latchlever should have side play  
 Min some---Max 0.008 inch

To Adjust  
 Position line feed clutch latchlever set collar.

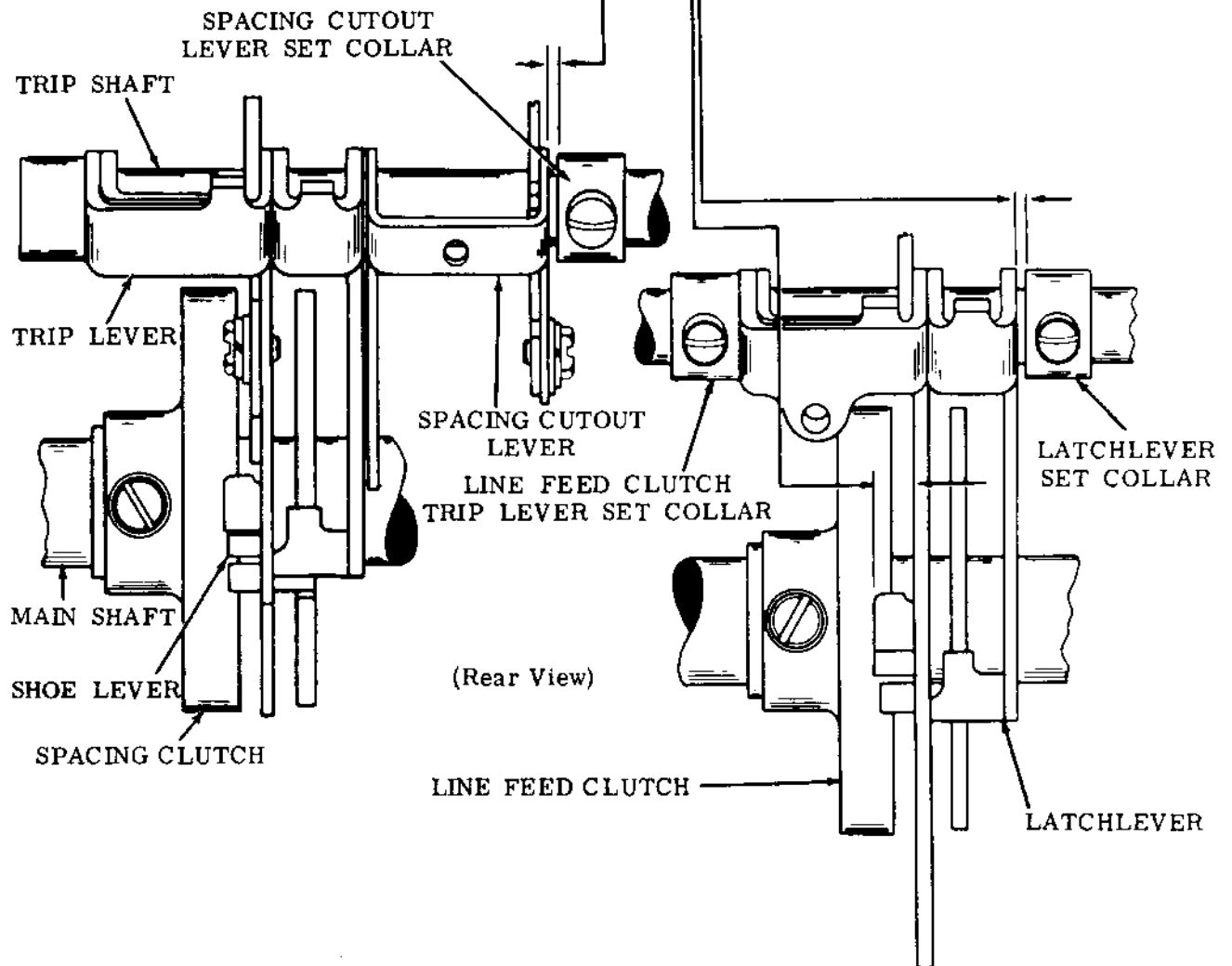



2.23 Main Shaft and Trip Shaft Mechanisms (continued)

SPACING CLUTCH TRIP LEVER

**Requirement**

Clearance between trip lever and clutch drum should be 0.018 to 0.035 inch less than clearance between shoe lever and drum at stop showing greatest clearance. There should be some overbite on all stop-lugs. Gauge by eye.

**To Check**

Disengage the clutch. Trip clutch trip lever and slowly rotate main shaft until trip lever is over the shoe lever. Take up play of shoe lever inward by snapping the trip lever over the shoe lever. Check clearance between shoe lever and drum at each stop position. With the trip lever at the stop position which yields greatest clearance, rotate main shaft slowly until the trip lever just falls off the stop-lug. Check clearance between trip lever and drum.

**To Adjust**

Position the trip lever by means of its clamp screw.

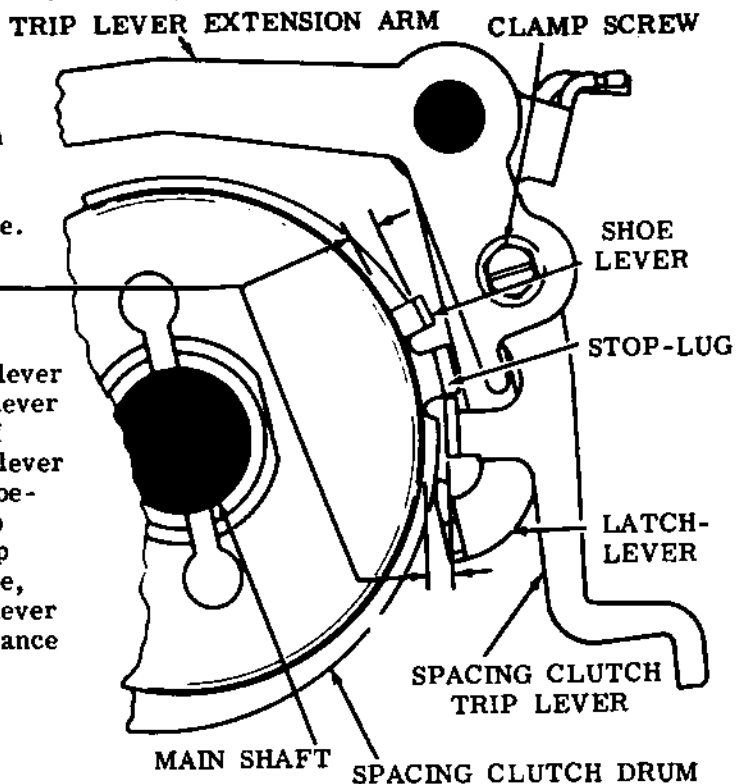

(Right Side View)

CLUTCH TRIP LEVER SPRING

**Requirement**

Clutch engaged and rotated until trip lever rests on stop-lug

Clutch Function	Min	Max
Spacing	1-1/2 oz	4 oz
Line Feed	11 oz	16 oz
Typebox	10 oz	13 oz
to move lever away from stop-lug.	5 oz	7-1/4 oz

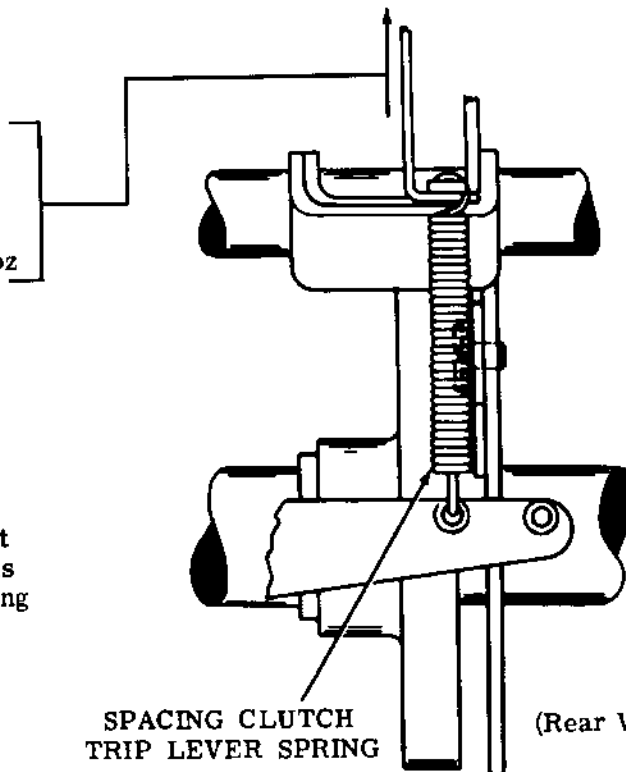

(Rear View)

INTERMEDIATE LEVER SPRING (On Units Equipped With Three Piece Spacing Clutch Trip Lever Bail)

**Requirement**

Trip spacing clutch and turn the main shaft so that the spacing clutch stop lever arm is in its unoperated position. Unhook the spring from the intermediate lever bail and pull spring to installed length.

Min 1-1/2 oz---Max 3-1/2 oz

## 2.24 Main Shaft and Trip Shaft Mechanisms (continued)

SPACING CLUTCH TRIP CAM FOLLOWER SPRING (If Used)

## Requirement

With the function clutch in the stop position, unhook the spring from the spring ear. Hook a scale to the spring loop.

Min 2-1/2 oz---Max 3-1/2 oz  
to pull the spring to its position length.

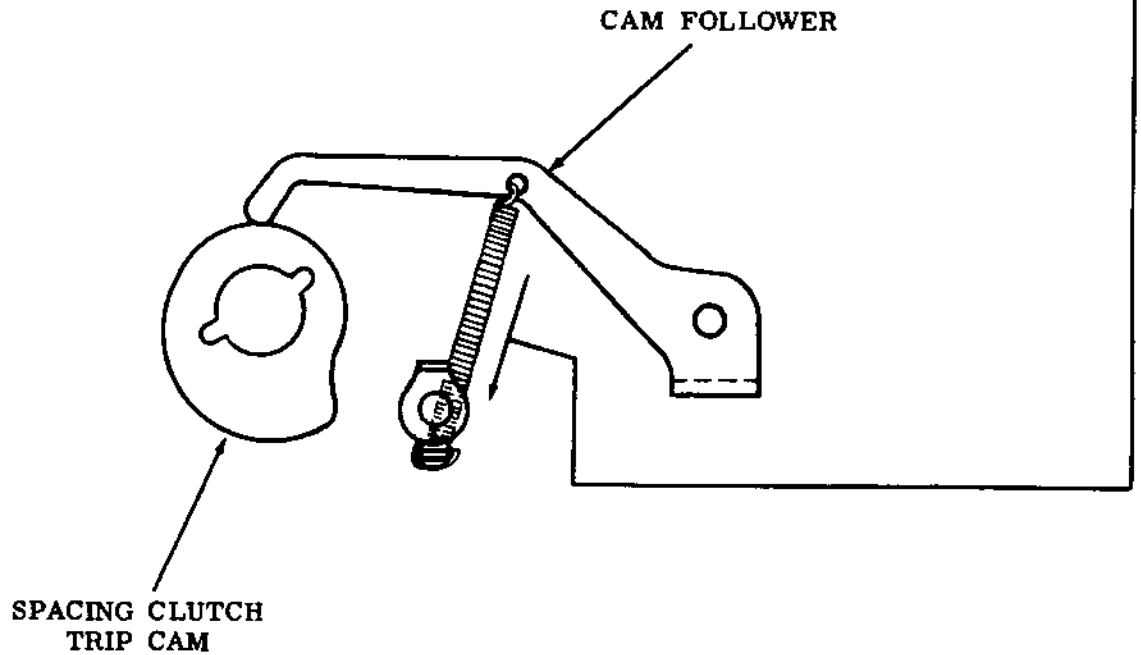

(Right Side View)

2.25 Main Shaft and Trip Shaft Mechanisms (continued)

LINE FEED CLUTCH TRIP LEVER ECCENTRIC POST

Requirement

Clearance between trip lever and clutch drum should be:

For 3-stop clutch — 0.018 inch to 0.035 inch

For 6-stop clutch — 0.012 inch to 0.025 inch

less than clearance between shoe lever and drum at stop which shows least clearance.

To Check

Disengage clutch. Trip clutch trip lever and slowly rotate main shaft until trip lever is over shoe lever. Take up play of shoe lever inward by snapping trip lever over shoe lever. Check clearance between shoe lever and drum at each stop position. With trip lever at stop position which yields least clearance, rotate main shaft slowly until trip lever just falls off stop-lug. Check clearance between trip lever and drum.

To Adjust

Back off trip lever adjusting screw and position trip lever eccentric stop post.

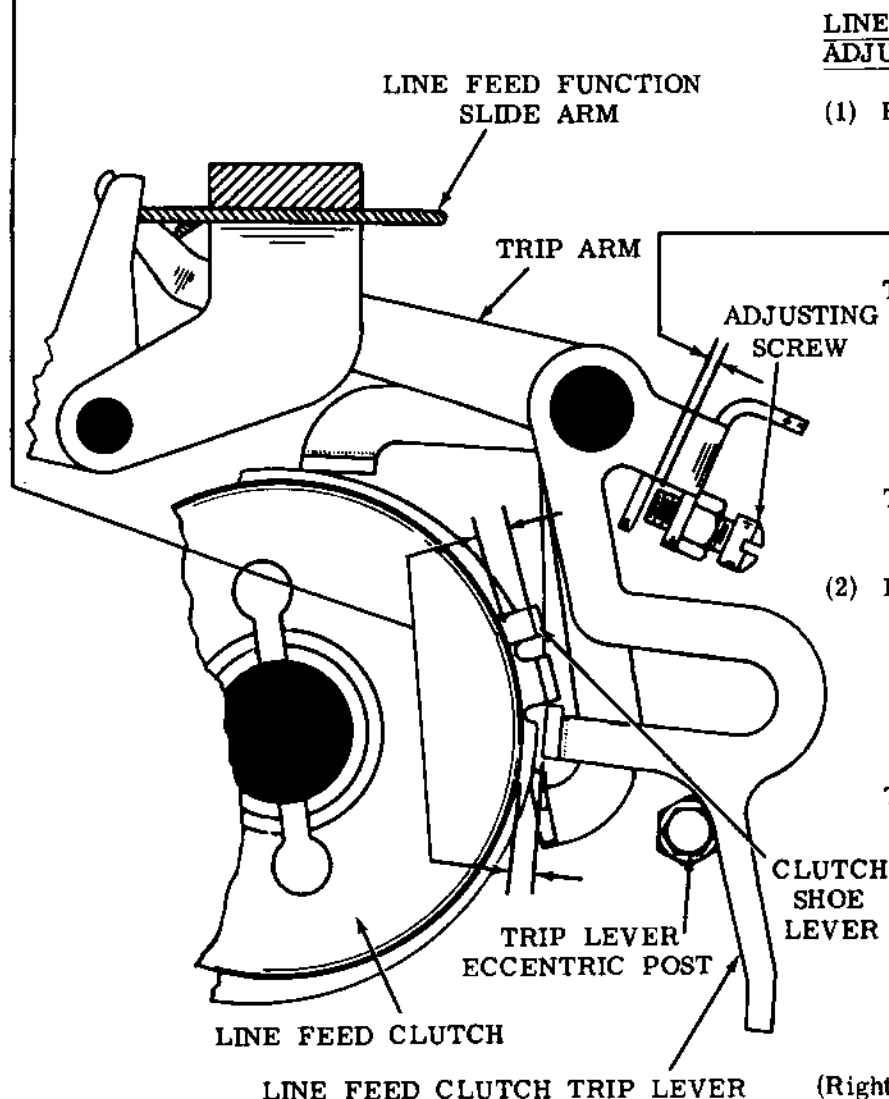

LINE FEED CLUTCH TRIP LEVER ADJUSTING SCREW

(1) Requirement

Clearance between end of trip lever adjusting screw and trip arm

Min some---Max 0.006 inch

To Check

Line feed function slide arm in rear position. Clutch trip lever against its eccentric post. Trip arm held against its function slide arm.

To Adjust

Position adjusting screw.

(2) Requirement

Clearance between line feed trip lever and all line feed clutch shoe levers should be Min 0.004 inch when form-out and vertical tab is selected.

To Adjust

Check and refine if necessary: Requirement (1), FUNCTION RESET BAIL BLADE (2.36), LINE FEED CLUTCH TRIP LEVER ECCENTRIC POST (2.25), MOUNTING BRACKET (3.01).

(Right Side View)

2.26 Main Shaft and Trip Shaft Mechanisms (continued)

TYPEBOX CLUTCH TRIP LEVER ECCENTRIC POST

**Requirement**

Typebox clutch disengaged. Trip lever should engage the clutch shoe lever by the full thickness of the shoe lever.

**To Adjust**

Position the trip lever eccentric post.

(Right Side View)

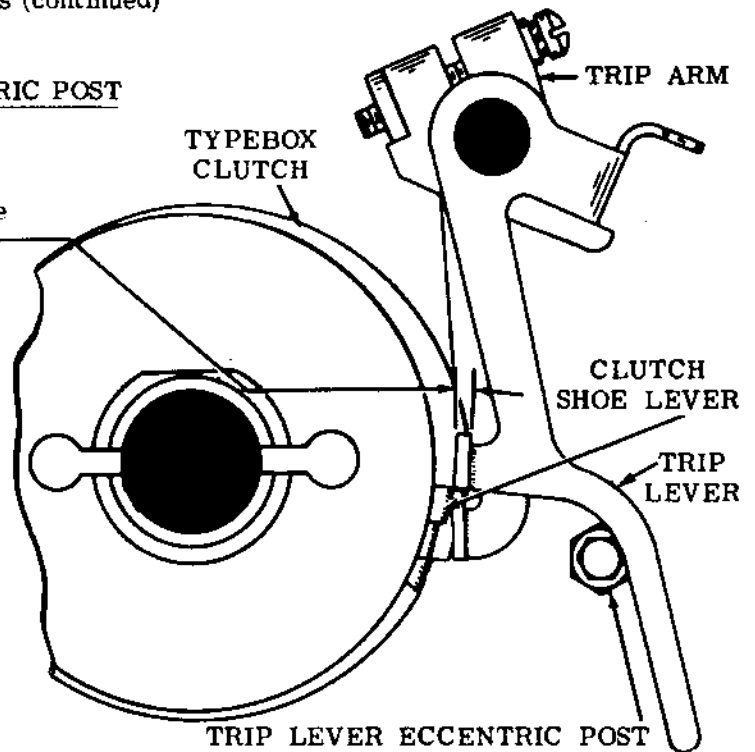

TYPEBOX CLUTCH TRIP LEVER TRIP ARM

(1) **Requirement**

Clutch trip shaft cam follower roller (see 2.20) on lowest surface of cam (located on codebar clutch). Clearance between inner face of typebox clutch trip lever and the clutch disc stop-lug.  
Min 0.025 inch---Max 0.045 inch

**To Adjust**

Loosen clamp screw and position stop.

(2) **Requirement**

When positioning the trip arm determine that the latchlever has some side play  
Max 0.008 inch

**To Adjust**

Position the clutch trip arm on its shaft with the clamp screw loosened.

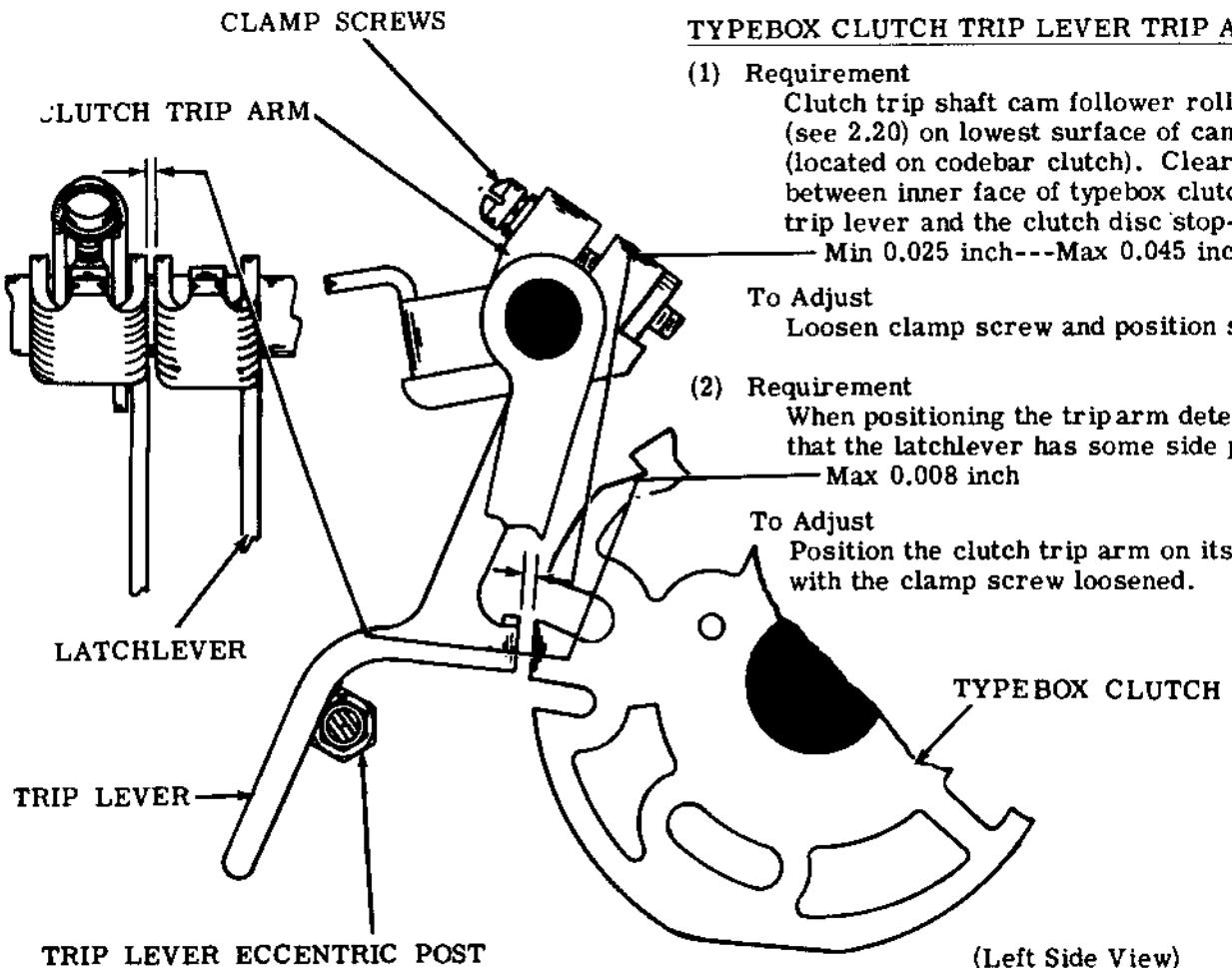

(Left Side View)

2.27 Main Shaft and Trip Shaft Mechanisms (continued)

CLUTCH SHOE LEVER

**Requirement**

Gap between clutch shoe lever and its stop-lug should be 0.055 inch to 0.085 inch greater when clutch is engaged than when the clutch is disengaged.

**To Check**

Disengage the clutch and measure the gap. Trip the clutch and rotate it until the clutch shoe lever is toward the bottom of the unit. Again measure the gap with the clutch thus engaged.

Note: On multiple stop clutches check the clearance at the stop-lug that is adjacent to the form in the clutch adjusting disc.

**To Adjust**

Loosen the two clamp screws on the clutch disc. Engage a wrench or screwdriver on the lug of the adjusting disc and rotate the disc.

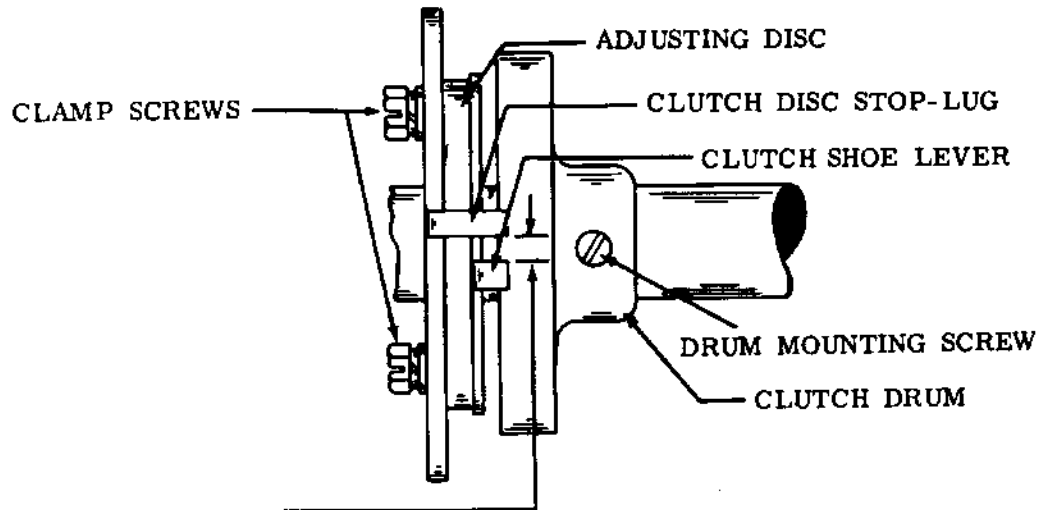

(Bottom View)

2.28 Main Shaft and Trip Shaft Mechanisms (continued)

CLUTCH SHOE LEVER SPRING

Requirement

Clutch engaged. Hold cam disc to prevent turning. Spring scale pulled at tangent to clutch.

One-Stop Clutches:

Min 15 oz---Max 20 oz

Multiple-Stop Clutches:

Min 16 oz---Max 22 oz

to move the shoe lever in contact with the stop-lug.

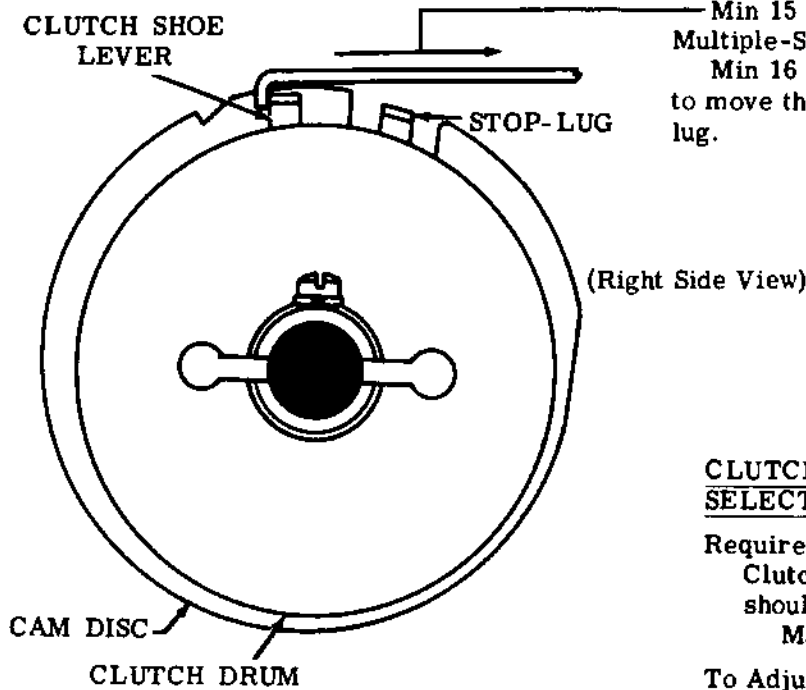

CLUTCH DRUM POSITION (EXCEPT SELECTOR)

Requirement

Clutch shoe lever held disengaged. Clutch should have some endplay  
Max 0.015 inch

To Adjust

Position each drum and spacing clutch set collar with mounting screws loosened.

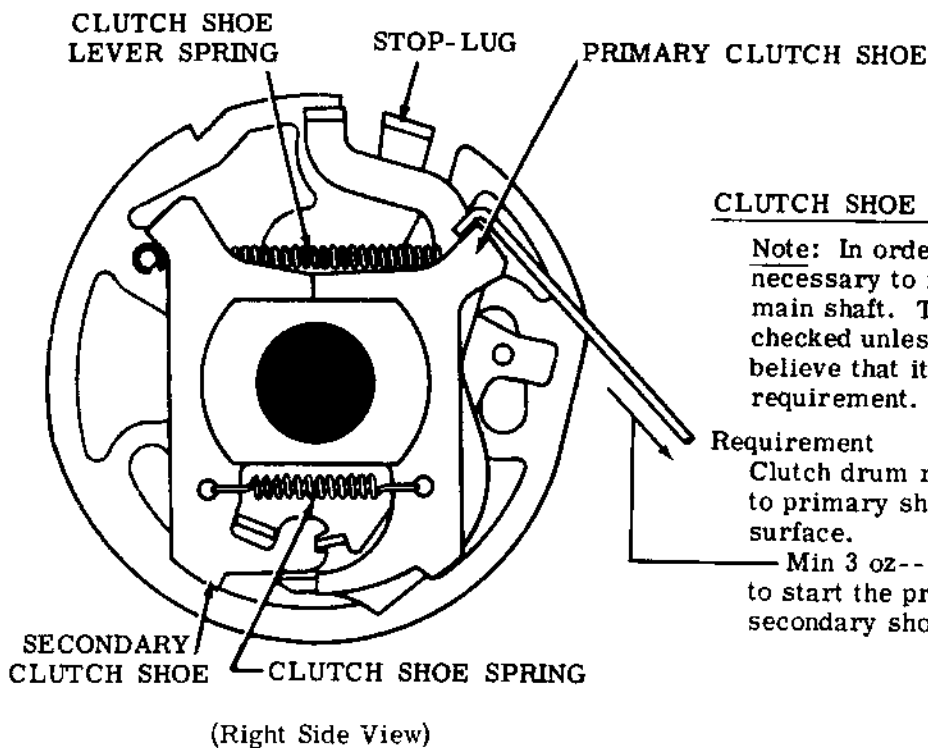

CLUTCH SHOE SPRING

Note: In order to check this spring, it is necessary to remove the clutch from the main shaft. Therefore, it should not be checked unless there is good reason to believe that it does not meet its requirement.

Requirement

Clutch drum removed. Spring scale applied to primary shoe at a tangent to the friction surface.

Min 3 oz---Max 5 oz

to start the primary shoe moving away from secondary shoe at point of contact.

2.29 Spacing Mechanism

**(B) SPACING GEAR PHASING**

**Requirement**

Spacing clutch disengaged. Index line on the spacing pawl should be as near as possible to the center of the two lines on the pawl retaining washer.

**To Adjust**

Remove the mounting screw from the spacing shaft gear. Hold the pawls in alignment and engage the spacing shaft gear with the clutch gear at a point where the spacing shaft gear mounting screw hole is in line with the tapped hole in the spacing shaft and insert the mounting screw.

RETAINING WASHER

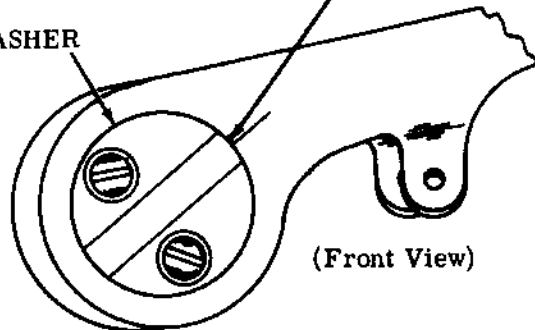

(Front View)

UPPER MOUNTING SCREW

FRONT PLATE

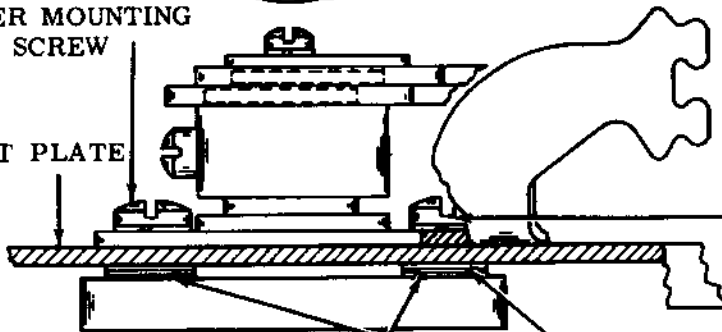

LOWER MOUNTING SCREW

SHIMS

**(A) SPACING GEAR CLEARANCE**

**Requirement**

Carriage fully returned. Minimum backlash of spacing gears without bind.

**To Adjust**

Insert shims between the spacing shaft bearing and front plate at upper mounting screw to increase clearance and at lower mounting mounting screw to decrease clearance.

SPACING SHAFT BEARING

SPACING SHAFT

MOUNTING SCREW



(Bottom View)

SPACING SHAFT GEAR

2.30 Line Feed, Platen Mechanism, and Positioning Mechanism

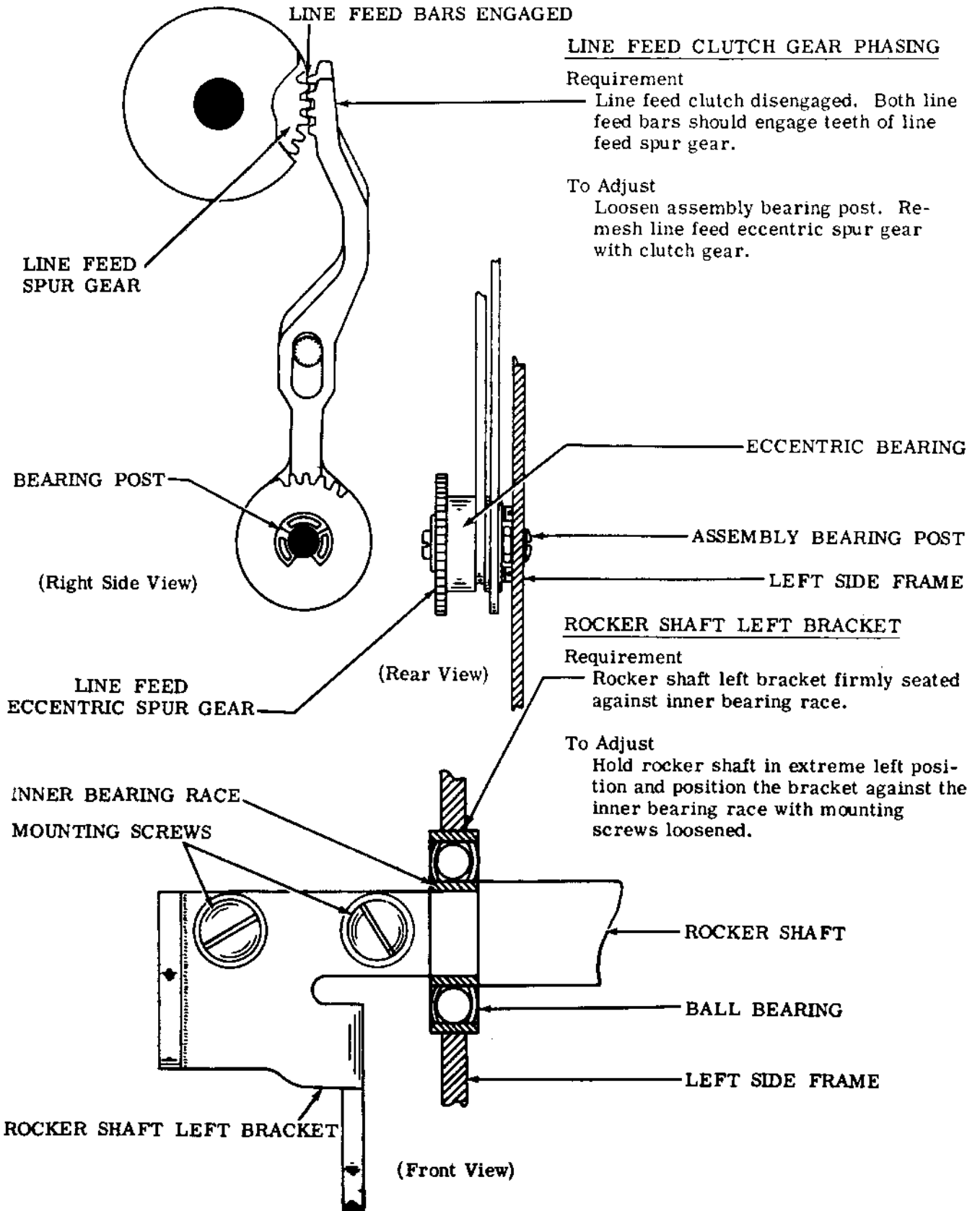



2.31 Positioning Mechanism

ROCKER SHAFT BRACKET ECCENTRIC STUD

(1) Requirement

Typebox clutch disengaged. Play in locking arm taken up towards front. Gap between lower side of locklever roller and top edge of shoulder on horizontal positioning locklever  
 Min 0.055 inch---Max 0.090 inch

To Adjust

Position eccentric stud in lower end of rocker shaft left bracket. Keep high part of eccentric (marked with dot) below center line of drive link.

(2) Requirement

Rocker shaft drive link bearing stud should be free to move, parallel to the main shaft, in its typebox clutch bearing when the clutch is in stop position and 180 degree position.

To Adjust

Refine the above to adjust.

Note: Any change in this adjustment after making related adjustments will require a rechecking of the following adjustments: HORIZONTAL POSITIONING DRIVE LINKAGE (2.38), RIGHT VERTICAL POSITIONING LEVER ECCENTRIC STUD (2.32), LEFT VERTICAL POSITIONING LEVER ECCENTRIC STUD (2.33), VERTICAL POSITIONING LOCKLEVER (2.34), RIBBON FEED LEVER BRACKET (2.59), SPACING TRIP LEVER BAIL CAM PLATE (2.35), PRINTING TRACK (2.53), PRINTING ARM (2.54), REVERSING SLIDE BRACKETS (2.37), and RIBBON REVERSE SPUR GEAR (2.58).

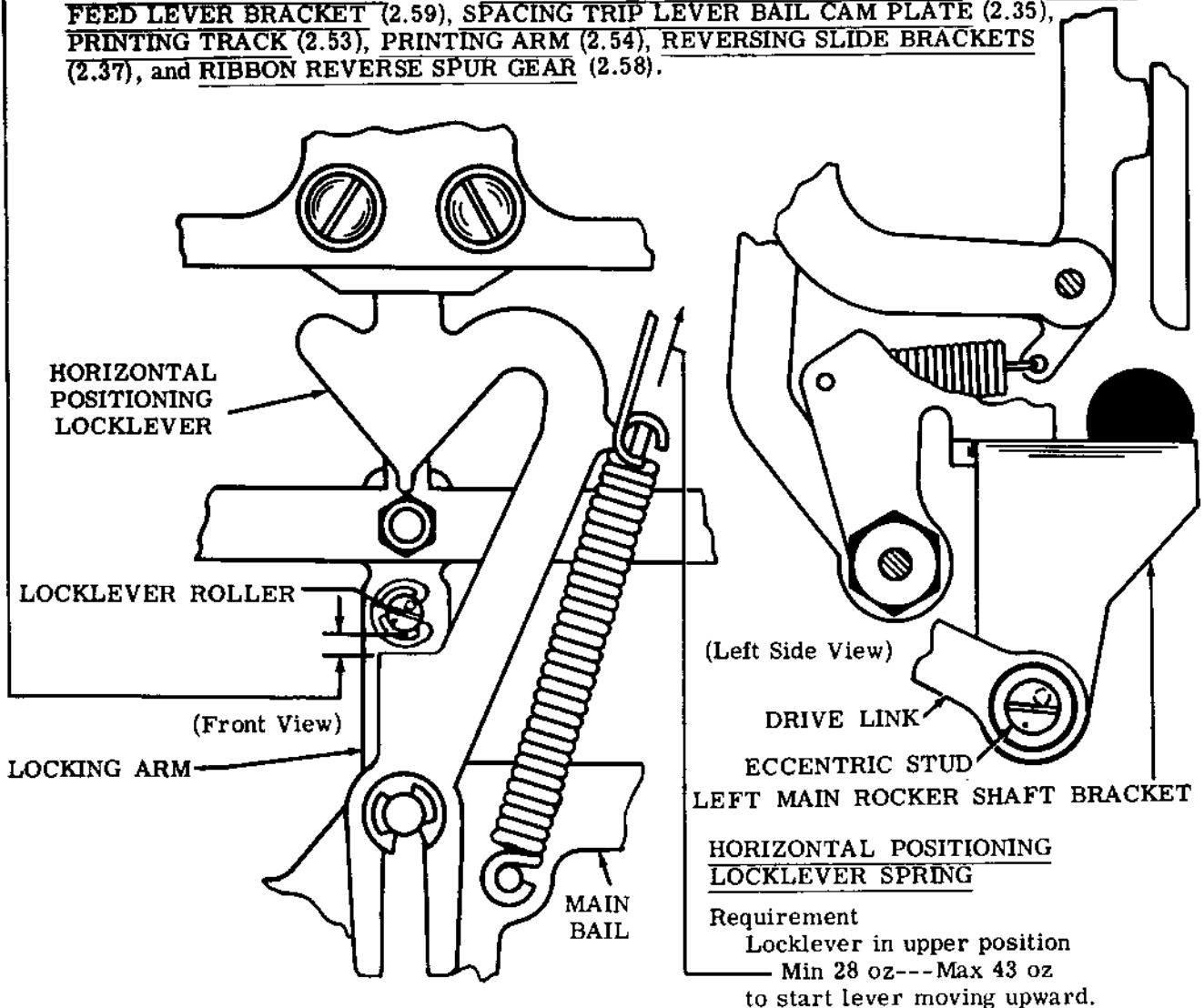

2.32 Positioning Mechanism (continued)

RIGHT VERTICAL POSITIONING LEVER ECCENTRIC STUD

Requirement

Typebox clutch disengaged, common codebar in spacing position. Play taken up by pressing downward on common codebar at guide block.

Min 0.030 inch---Max 0.050 inch  
clearance between the toe of vertical positioning lever and the bottom of the common codebar when play is taken up to make clearance a minimum.

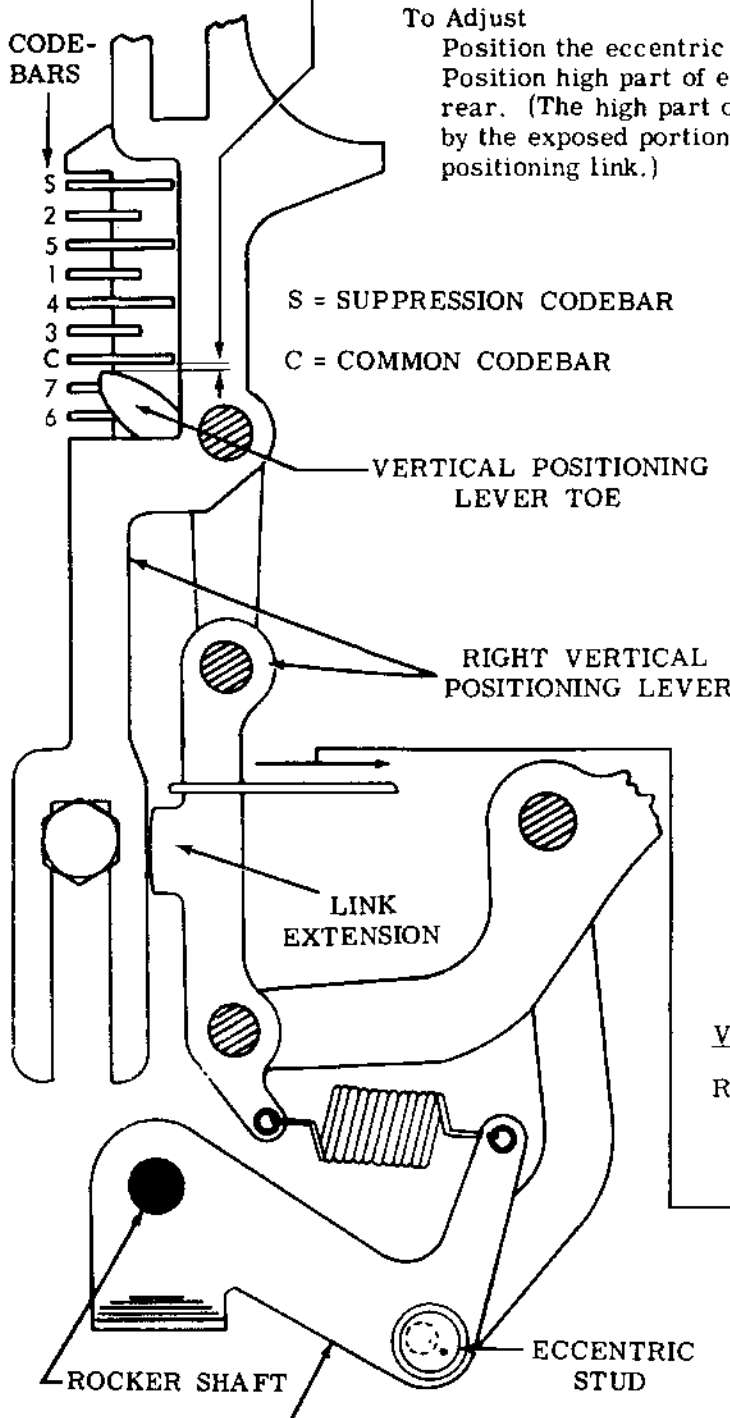

ROCKER SHAFT BRACKET (Right Side View)

To Adjust

Position the eccentric stud in the right rocker shaft bracket. Position high part of eccentric (marked with dot) toward the rear. (The high part of the eccentric can also be identified by the exposed portion of the flat surface of the vertical positioning link.)

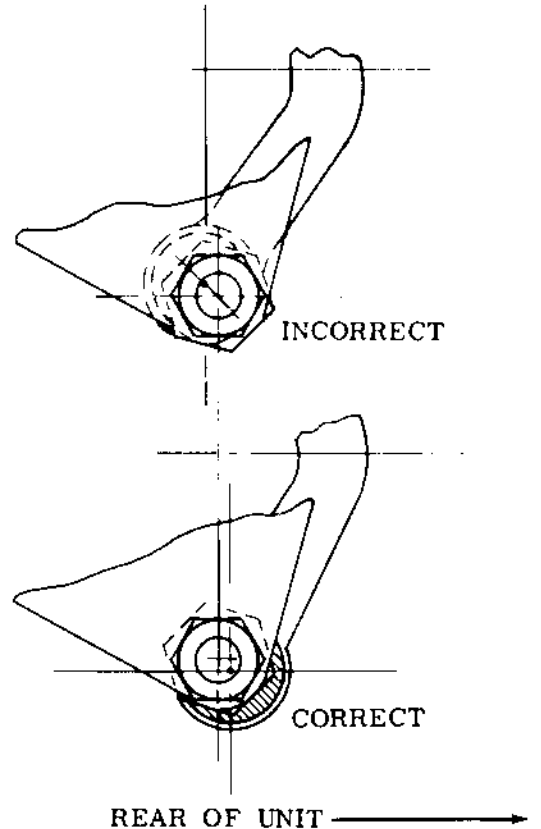

VERTICAL POSITIONING LEVER SPRING

Requirement

Vertical positioning lever toes (right and left) in contact with the suppression codebar, levers not buckled.

Min 4 oz---Max 12 oz  
to move the link extension away from the vertical positioning lever. Check both right and left springs.

2.33 Positioning Mechanism (continued)

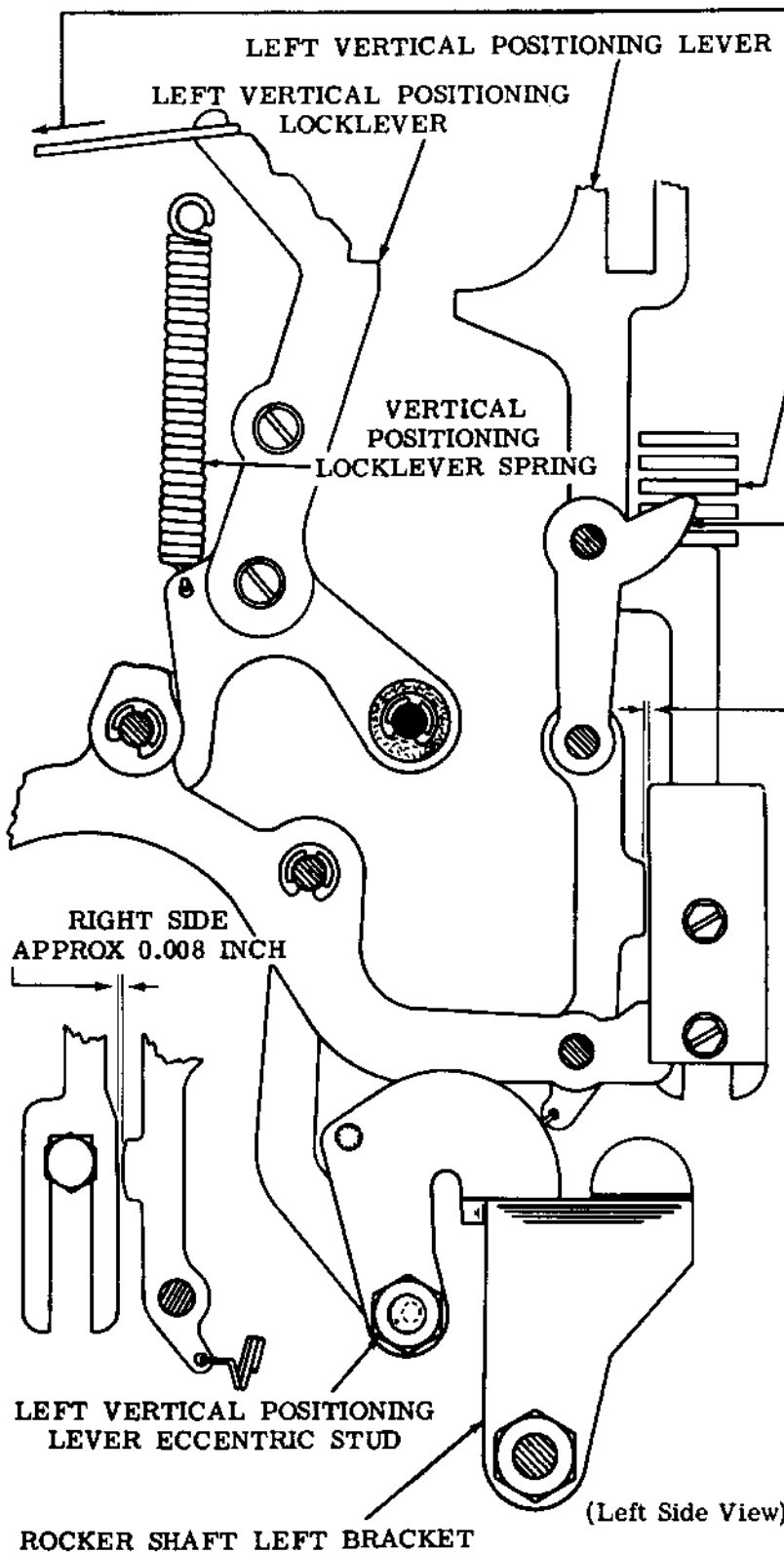

VERTICAL POSITIONING LOCK-LEVER SPRING

Requirement  
 Typebox clutch disengaged  
 Min 5 oz---Max 8 oz  
 to start locklever moving.  
 Check right and left springs.

COMMON CODEBAR

VERTICAL POSITIONING LEVER TOE

LEFT VERTICAL POSITIONING LEVER ECCENTRIC STUD

Requirement  
 Right and left vertical positioning levers should buckle equally within 0.006 inch.

To Check

Common codebar in spacing position. Trip typebox clutch. Rotate main shaft until right vertical positioning lever toe touches common codebar, buckling its lower link approximately 0.008 inch. Left vertical positioning lever toe should touch common codebar, buckling its lower link equally within 0.006 inch.

To Adjust

Position eccentric stud on rocker shaft left bracket inner arm. Position high part of cam (marked with dot) toward rear.

Note: On units containing intermediate storage mechanism, position the eccentric stud in the right rocker shaft bracket. (The high part of the eccentric can also be identified by the exposed portion of the flat surface of the vertical positioning link.)

2.34 Positioning Mechanism (continued)

VERTICAL POSITIONING LOCKLEVER

(1) Requirement

Rubout combination set up on codebars.  
Main side operating levers at upper end of travel. Upper notch of vertical positioning locklever fully engaged (manually if necessary) with vertical slide projection. Upper surface of follower arm rear extension should be  
—Min in contact with---Max 0.004 inch away from inner extension of main side lever.

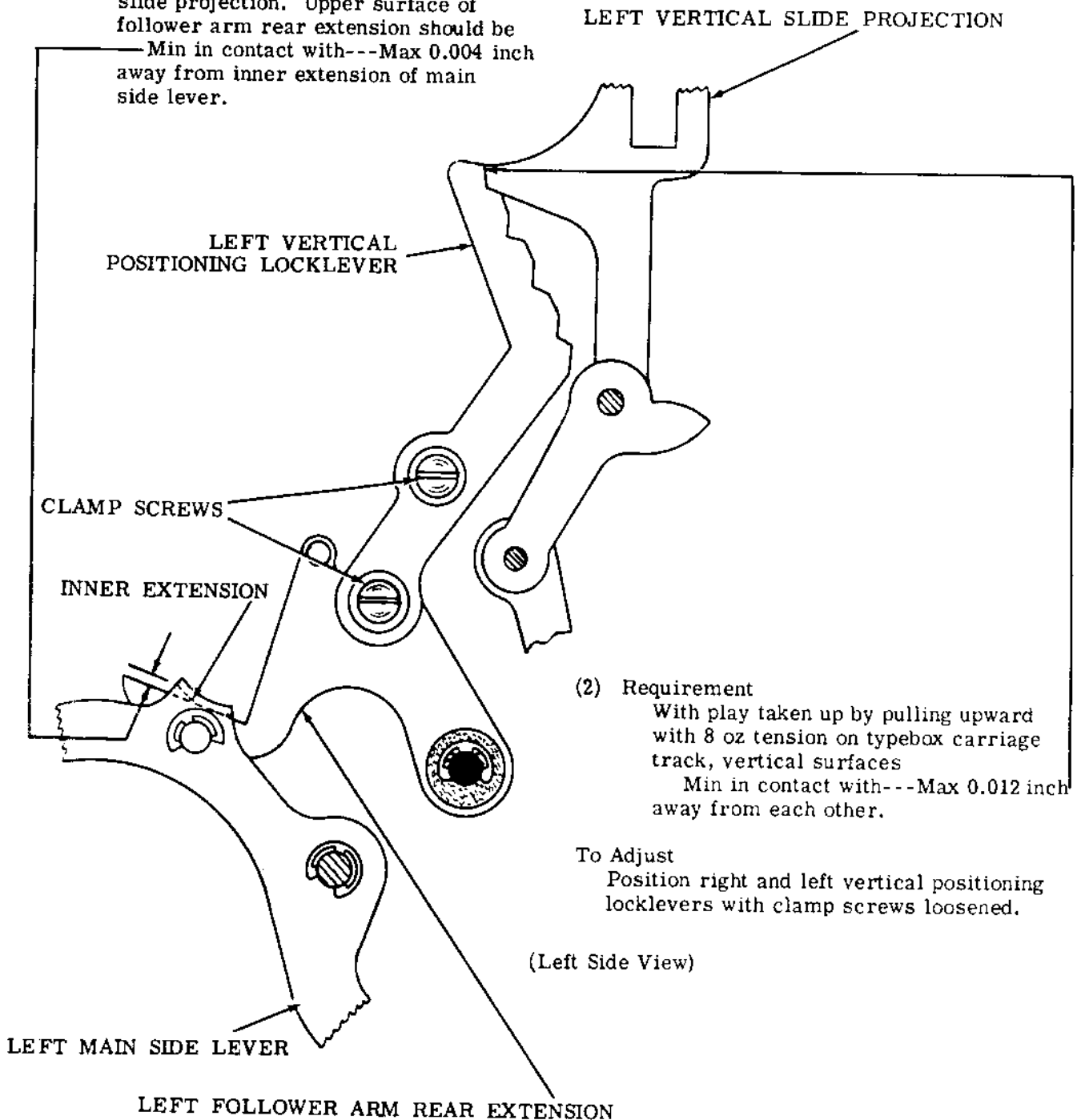

(2) Requirement

With play taken up by pulling upward with 8 oz tension on typebox carriage track, vertical surfaces  
Min in contact with---Max 0.012 inch away from each other.

To Adjust

Position right and left vertical positioning locklevers with clamp screws loosened.

(Left Side View)

2.35 Spacing Mechanism (continued)

(A) SPACING TRIP LEVER BAIL CAM PLATE

**Requirement**

Spacing trip lever arm in upward position. Typebox clutch rotated through approximately one-half of its cycle. All function pawls disengaged from function bars. Clearance between top surface of trip lever arm extension and spacing trip lever shoulder

Min 0.010 inch---Max 0.040 inch

**To Adjust**

Position cam plate on rocker shaft with mounting screws loosened. Position forward edge of cam plate parallel to shaft.

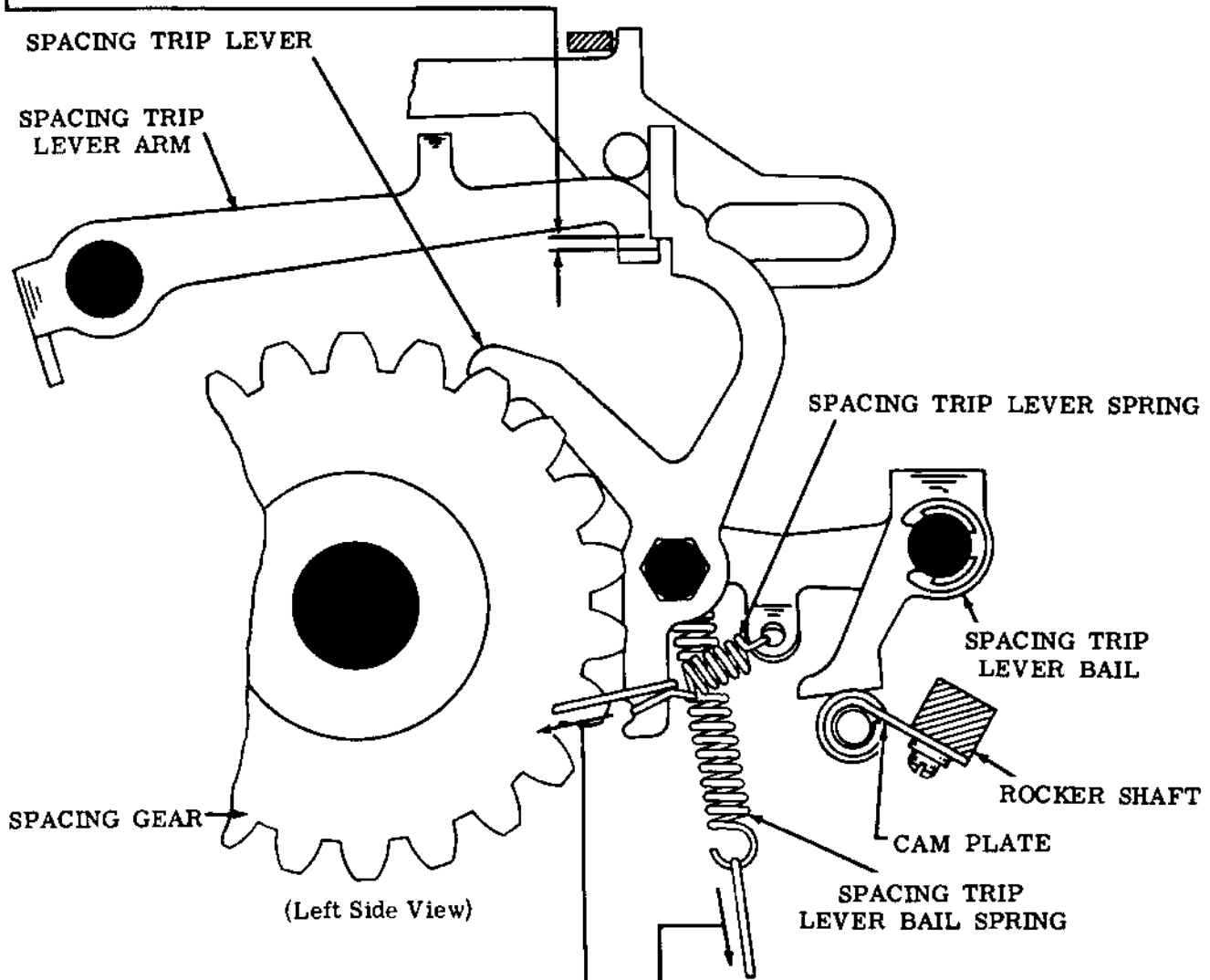

(B) SPACING TRIP LEVER SPRING

**Requirement**

Typebox clutch disengaged.

Min 2-1/2 oz---Max 5 oz  
to start lever moving.

(C) SPACING TRIP LEVER BAIL SPRING

**Requirement**

Spacing trip lever bail against stop.  
Spacing trip lever bail spring unhooked.

Min 8 oz---Max 12 oz  
to pull spring to installed length.

2.36 Function Mechanism

(B) FUNCTION RESET BAIL SPRING

**Requirement**

With typing unit upside down, hold no. 1 codebar in its marking position so that no function bar is selected. Rotate the main shaft until the function reset bail springs are in their minimum length position. Place pull rod of 32 ounce scale between clutch trip shaft and space suppression bail, hook scale on front edge of reset bail (at middle of bail) and pull toward rear. Min 10 oz---Max 22 oz to start bail moving.

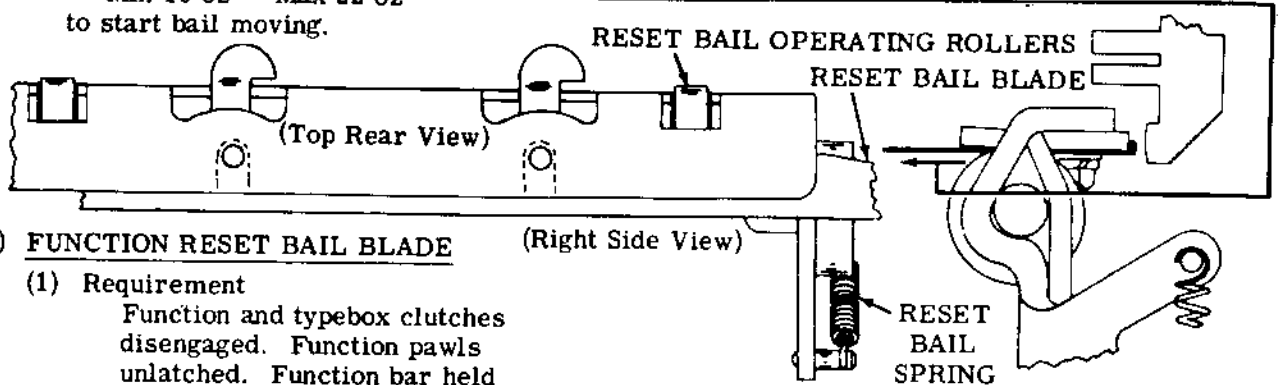

(A) FUNCTION RESET BAIL BLADE

(1) **Requirement**

Function and typebox clutches disengaged. Function pawls unlatched. Function bar held in maximum rearward position. Clearance between function bar and reset bail blade

Min 0.018 inch---Max 0.035 inch

**To Check**

Measure clearance at bars located in stunt box slots 1, 4, 11, 18, 23, 33, 38, and 41. If there is no bar in a designated slot, use nearest bar. If there is a bar on each side of a designated vacant slot, use bar in highest numbered slot. (Note: Facing rear of unit, slots are numbered from left to right.)

**To Adjust**

Position blade on reset bail with its mounting screws friction tight.

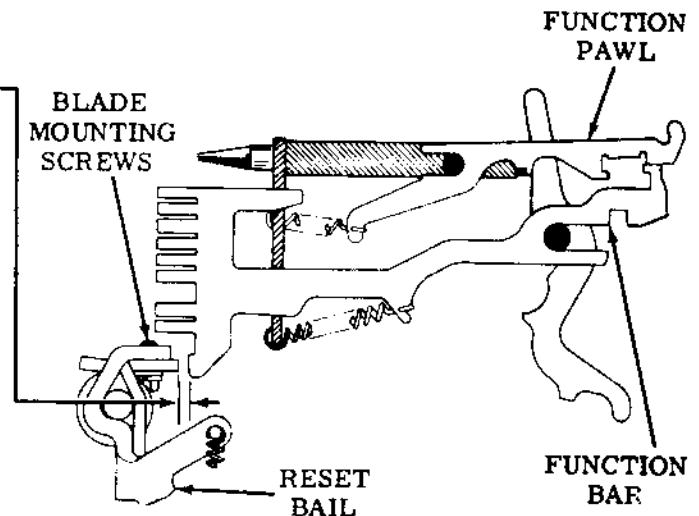

(2) **Requirement**

Function pawl should overtravel function bar by Min 0.002 inch

**To Check**

If carriage return lever adjustment has not been made, its clamp screw should be loosened. Position function clutch so that lug on clutch disc is toward bottom of unit. Strip off any selected function pawls. Hold function lever in maximum rearward position (do not put over 2 lb of tension on lever) and hold function pawl to rear with a tension of 32 oz. (As load on reset bail affects overtravel, do not latch more than one pawl at a time.) Measure clearance. Repeat for each function pawl on stunt box.

**To Adjust**

If necessary, refine Requirement (1) within the following limits

Min 0.018 inch---Max 0.035 inch

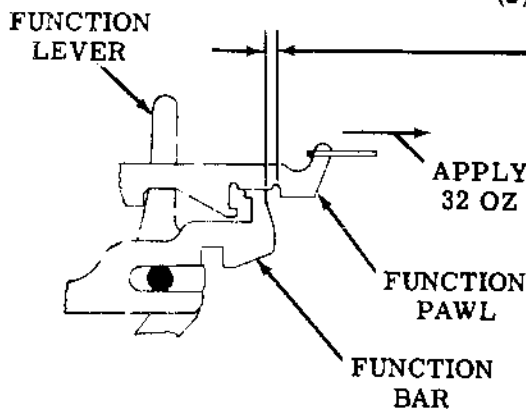

(Right Side View)

2.37 Positioning Mechanism (continued)

(A) REVERSING SLIDE DETENT SPRING

Requirement

Slide in left hand position. Scale hooked in upper right hand detent notch.

Min 2 oz---Max 4-1/2 oz  
to start detent moving.

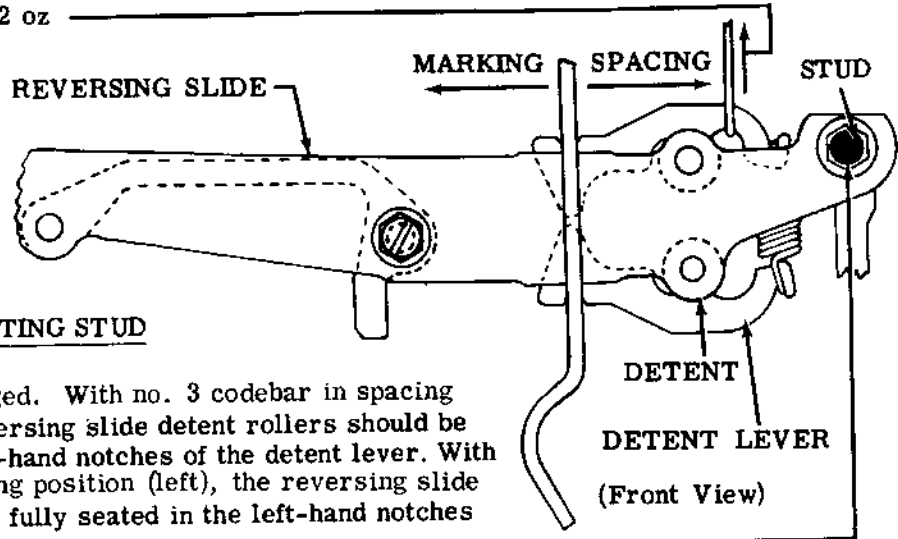

(B) REVERSING SLIDE ADJUSTING STUD

Requirement

Typebox clutch disengaged. With no. 3 codebar in spacing position (right), the reversing slide detent rollers should be fully seated in the right-hand notches of the detent lever. With no. 3 codebar in marking position (left), the reversing slide detent rollers should be fully seated in the left-hand notches of the detent lever.

To Adjust

Position the reversing slide stud in its elongated hole with its mounting nut loosened.

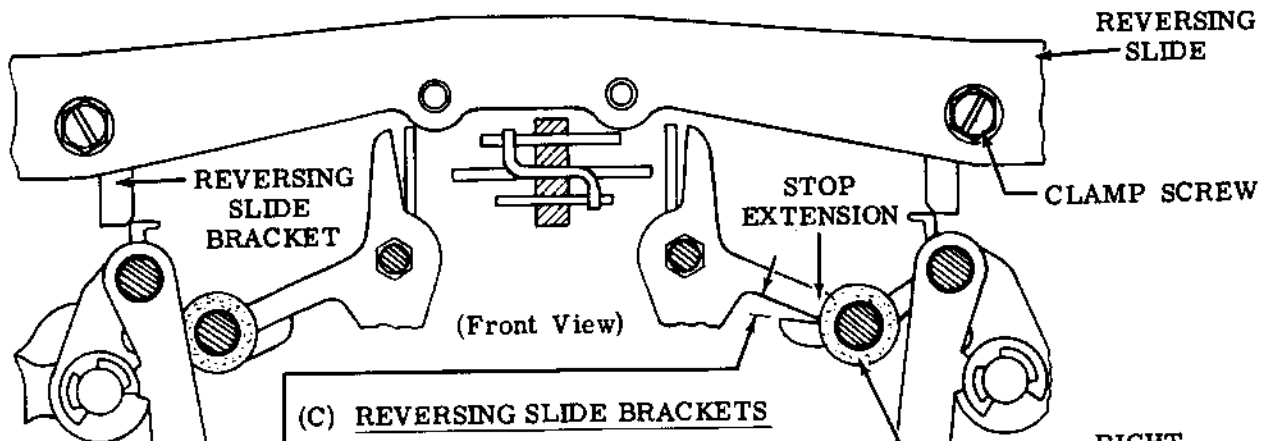

(C) REVERSING SLIDE BRACKETS

Requirement

Typebox clutch, codebar clutch, and function clutch disengaged. Reversing slide moved to right and left through its full travel. Right motion should buckle left horizontal positioning drive linkage and left motion should buckle right horizontal positioning drive linkage. The amount of buckling in each case should be  
Min 0.035 inch---Max 0.050 inch  
measured at point of maximum clearance.

To Adjust

Position each reversing slide bracket with its clamp screw loosened.

## 2.38 Positioning Mechanism (continued)

HORIZONTAL POSITIONING DRIVE LINKAGE

## (1) Requirement

Typebox clutch disengaged. Codebars in spacing position. Clearance between longest horizontal stop and positioning linkage slides

Min 0.090 inch---Max 0.110 inch

clearance at two sides should be equal within 0.008 inch, with positioning linkage in straight position. Move reversing slide to right and left to check both sides.

## To Adjust

Loosen two screws in drive linkage bearing posts and two screws in bearing posts tie bar. With reversing slide in right hand position, locate right hand bearing post so clearance between longest horizontal stop and right hand positioning lever slide

Min 0.095 inch---Max 0.105 inch

Tighten two screws in bearing posts tie bar. Do not tighten bearing posts mounting screws. Move reversing slide to left hand position, check clearance between longest horizontal stop and left hand positioning lever slide. Equalize clearance at right and left positioning slides within 0.008 inch by moving two bearing posts as a unit.

## (2) Requirement

Horizontal positioning mechanism should be free of jams or binds.

## To Check

Typebox clutch disc should have some movement in the normal direction of rotation in the stop position.

Note: Each positioning linkage should return freely to its straight position after buckling. Recheck REVERSING SLIDE BRACKETS (2.37).

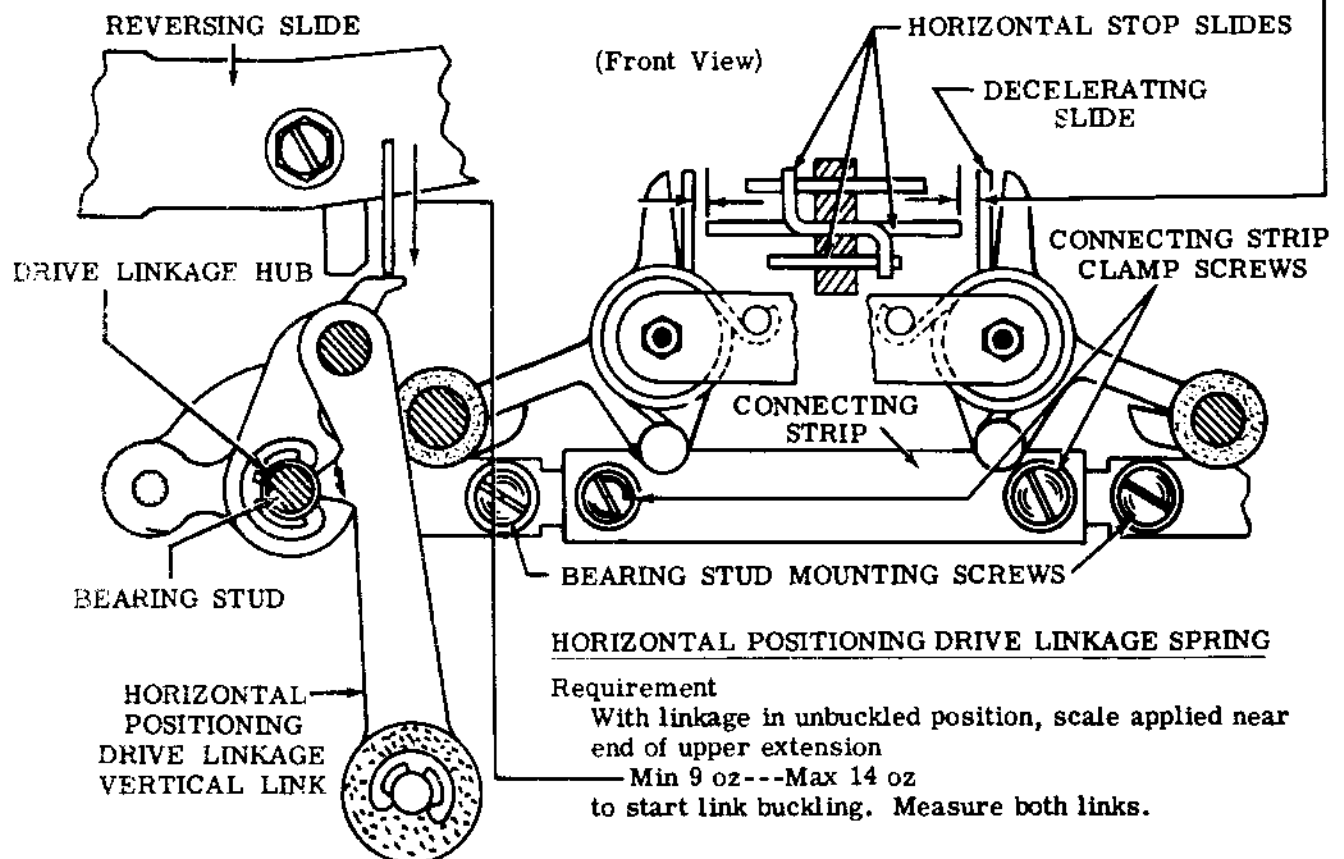



2.39 Positioning Mechanism (continued)

SHIFT LINKAGE (PRELIMINARY)

Requirement

With codebar and typebox clutches disengaged  
 Min 0.030 inch---Max 0.050 inch  
 between shift breaker slide and pad on shift  
 link, with link buckled and shift breaker slide  
 pushed upwards against stop. Clearance at  
 two sides equal within 0.010 inch.

To Adjust

Position shift link mounting brackets up or  
 down by means of pin in mounting holes.

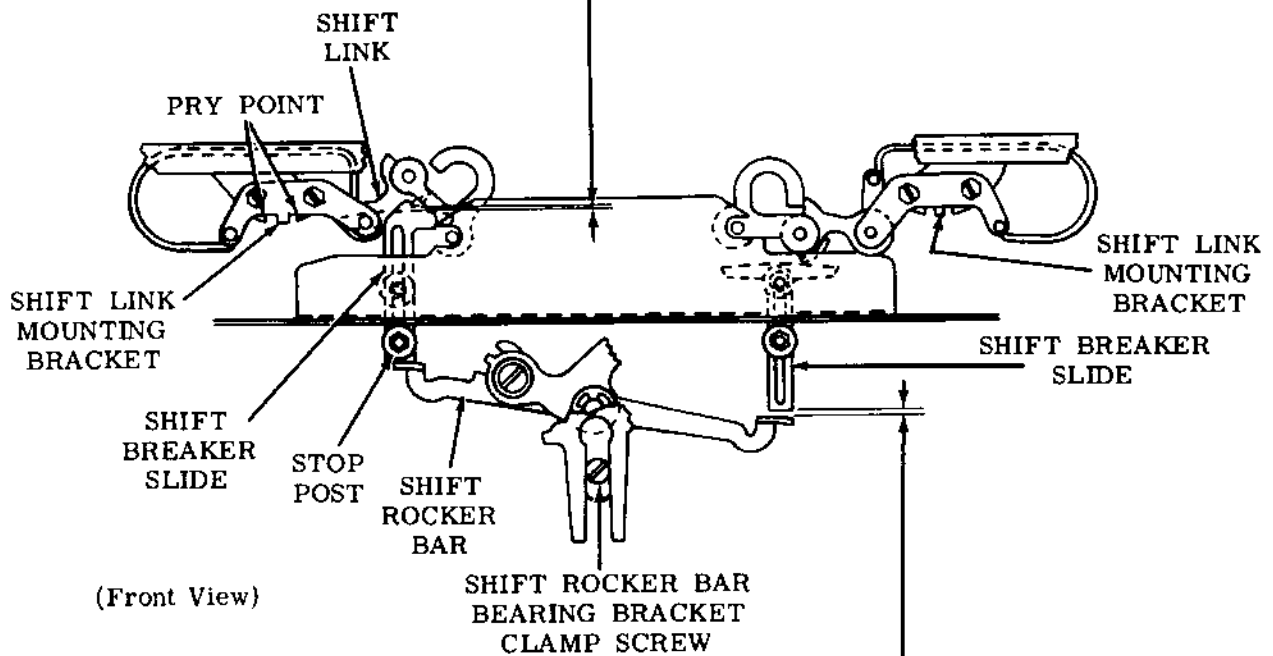

(Front View)

SHIFT ROCKER BAR BEARING BRACKET

Requirement

Note: Verify SHIFT ROCKER LEVER (2.41)  
 before proceeding with this adjustment.

Codebar and typebox clutches disengaged.  
 Clearance between shift rocker bar and lower  
 end of right shift breaker slide

Min 0.050 inch---Max 0.070 inch

Check left side in similar manner.

To Check

Raise left end of shift rocker bar to uppermost  
 position, holding left shift breaker slide against  
 stop. Make sure right shift link is straight, and  
 hold right shift breaker slide against shift link pad.

To Adjust

Position shift rocker bar bearing bracket with  
 clamp screw friction tight.

## 2.40 Positioning Mechanism (continued)

HORIZONTAL SHIFT LINK SHOCK ABSORBER SPRING**Requirement**

Typebox carriage at left side of typing unit. Right hand shift link in straight or unbuckled position.

Min 10 lb---Max 12 lb  
to start shock absorber slide moving.

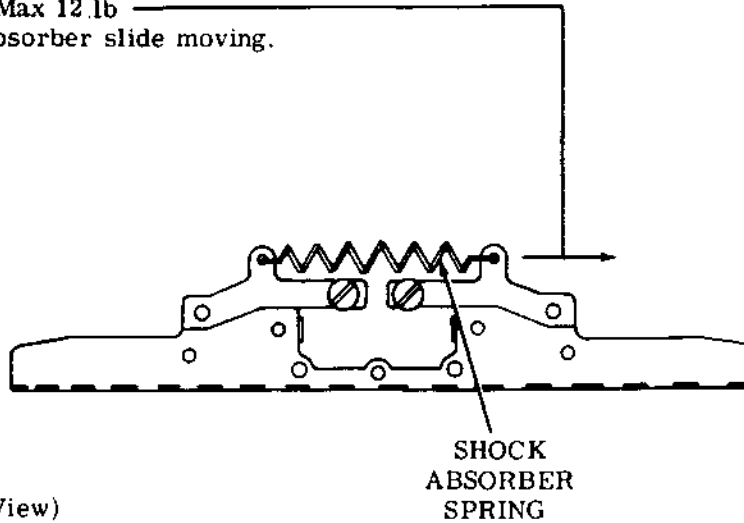
DECELERATING SLIDE SPRING**Requirement**

Printing bail in downward position. Printing carriage and decelerating slide assembly in right hand position.

Min 1/2 oz---Max 1-1/2 oz  
to start the slide moving. With the printing carriage and decelerating slide in their left hand position, check the left hand decelerating slide spring.

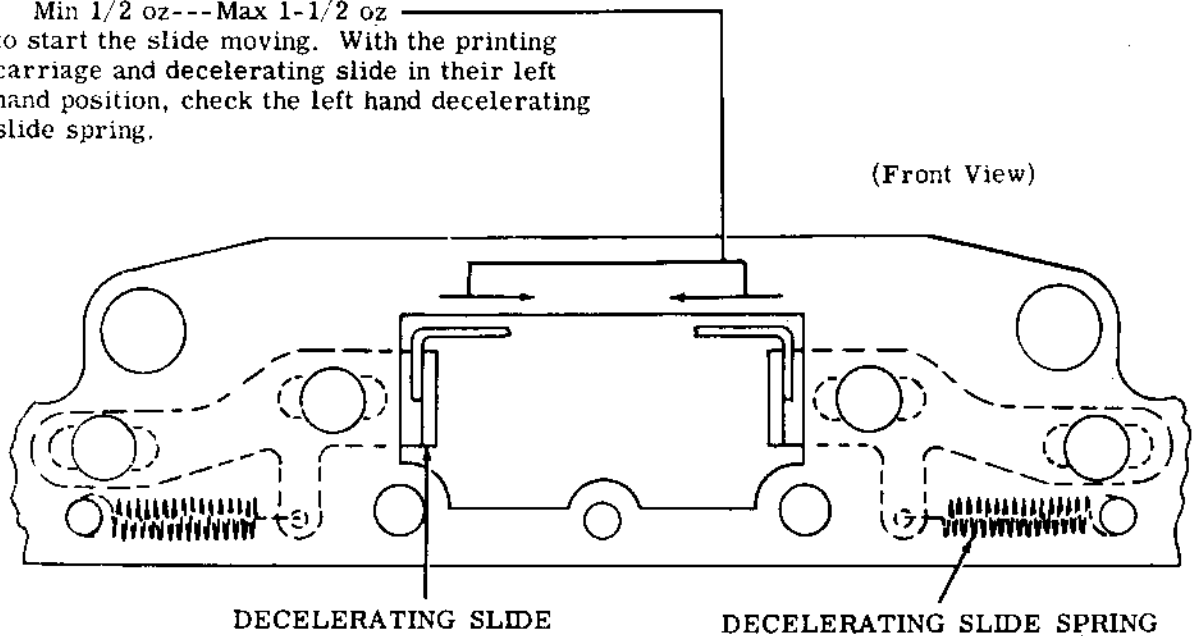

2.41 Positioning Mechanism (continued)

SHIFT ROCKER LEVER

Requirement

With the codebar bail arm assembly roller on the high part of the cam, make a left and right shift selection. On each shift selection measure the clearance between the raised end of the shift rocker bar and the lower end of the associated shift breaker slide. On the shift selection which yields the smaller clearance, take up the play in an upward direction at the lower end of the shift rocker lever with a force of 2 ounces. The resulting clearance should be equal within 0.010 inch to the clearance between the raised end of the shift rocker bar and the lower end of the associated shift breaker slide when the opposite shift selection is made.

To Adjust

Loosen shift rocker lever clamp screw friction tight and position shift rocker lever.  
Tighten clamp screw.

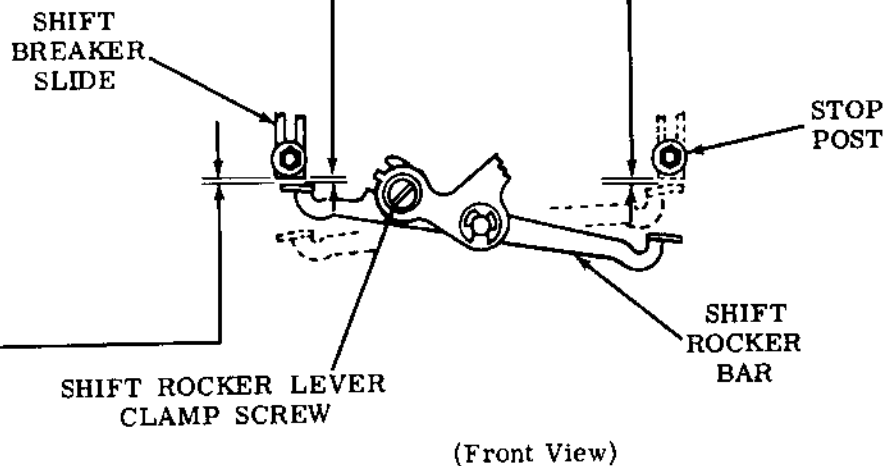

SHIFT DRIVE PAWL OPERATING BAIL

Requirement

With shift drive pawl operating bail cam follower on high dwell of cam, clearance between shift rocker bar and lower end of raised shift breaker slide  
Min 0.005 inch---Max 0.025 inch  
when slide is held against stop. To be held within  
Min 0.005 inch---Max 0.035 inch  
when the 0.010 inch parallel requirement is held in the SHIFT ROCKER LEVER adjustment.

To Adjust

Position operating bail cam follower arm by means of its clamp screw. Recheck SHIFT ROCKER LEVER adjustment.

SHIFT ROCKER BAIL SPRING (For Applicable Units)

Requirement

Position the shift rocker bail alternately in the letters or figures position. While spring is extended it should require  
Min 2 oz---Max 6 oz  
to pull spring to its installed length.

2.42 Positioning Mechanism (continued)

SHIFT DRIVE PAWL GUIDE BRACKET

Requirement

Codebar clutch disengaged. Bail arm assembly spring removed. Movement of its bail arm assembly should cause shift drive pawl to move freely in its guide bracket throughout its entire travel. Clearance between shift drive pawl and bottom of slot in guide bracket

Min Some---Max 0.010 inch

To Adjust

Position shift drive pawl guide bracket with clamp screw and clamp nut loosened friction tight. Recheck requirement after guide bracket is tightened.

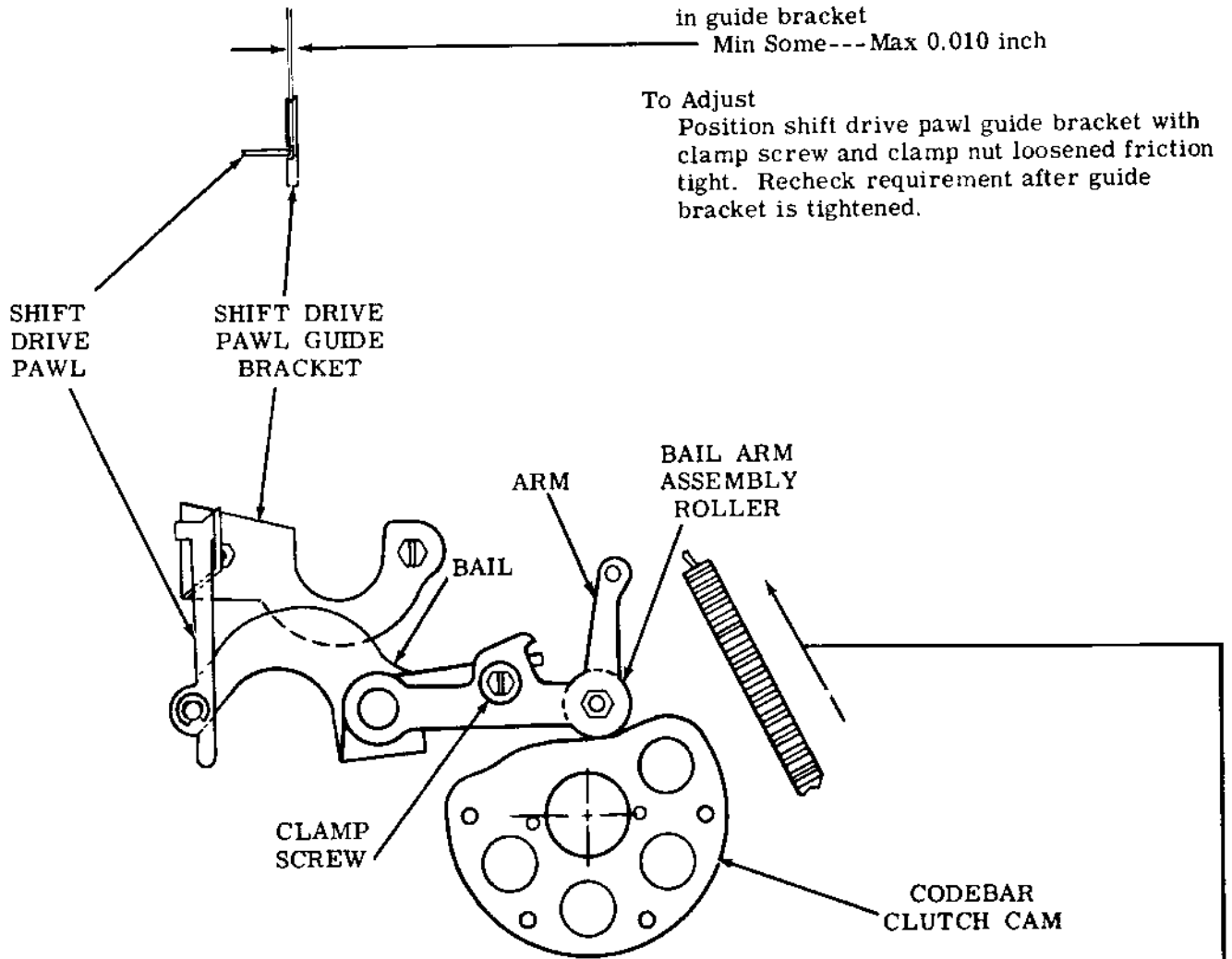

(Bottom View)

BAIL ARM ASSEMBLY SPRING

Requirement

Drive pawl bail arm assembly on low part of cam. Unhook spring.

Min 6 oz---Max 12 oz  
to pull spring to installed length.

2.43 Positioning Mechanism (continued)

SHIFT SELECTOR ARM BELLCRANK

Requirement

Shift pushlever in marking position (toward front), selector clutch and codebar clutch disengaged. Shift pawl should clear end of shift drive pawl bearing post.

Min some---Max 0.025 inch

Note: On units containing storage mechanism, shift pushlever in spacing position (toward rear), shift intermediate storage lever marking, selector clutch and codebar clutch disengaged. Shift pawl should clear end of shift drive pawl bearing post.

Min some---Max 0.025 inch

Recheck INTERMEDIATE ARM BACKSTOP BRACKET (2.15). Refine requirement above.

To Adjust

Loosen shift selector arm bellcrank clamp screw friction tight. Position to meet requirement.

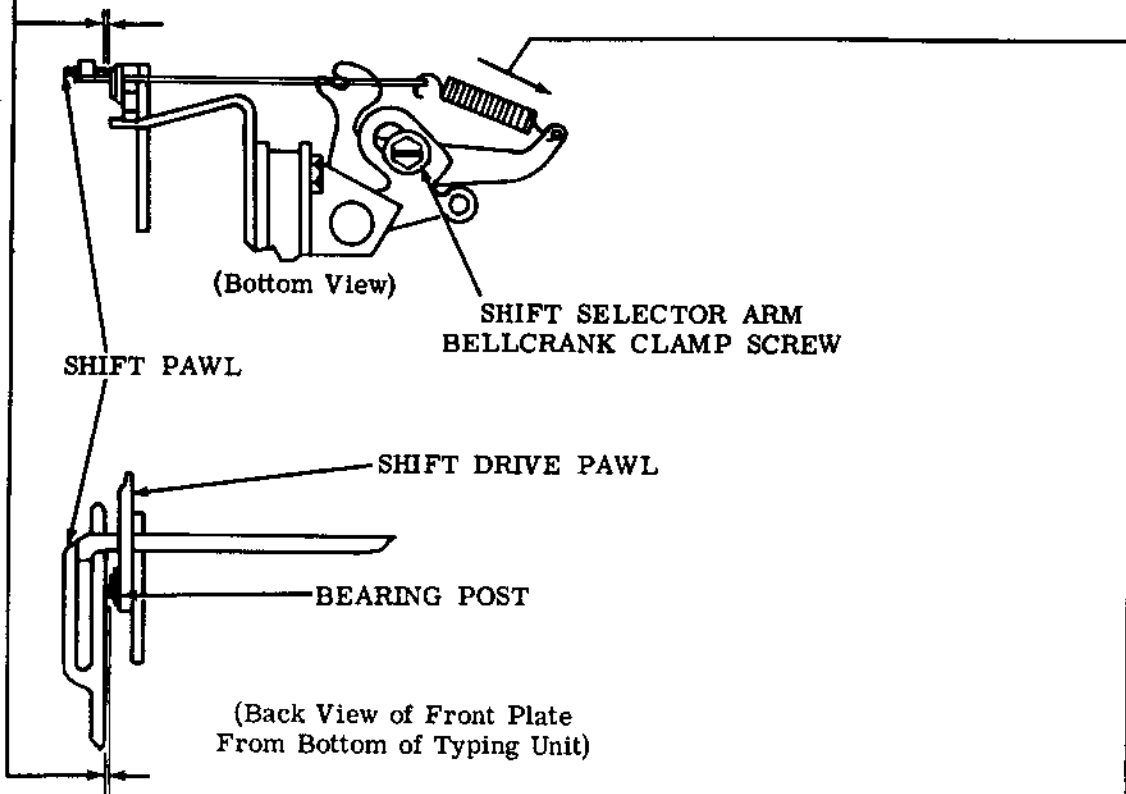

SHIFT PAWL SELECTOR LINK YIELD SPRING

Requirement

Shift pushlever in marking position, selector clutch and codebar clutch disengaged

Min 5 oz---Max 7 oz  
to pull spring to installed length.

2.44 Spacing Mechanism (continued)

**Note:** Check related adjustments, (See 2.48, 2.55, and 2.56) if the following adjustments are remade.

OSCILLATING RAIL SLIDE POSITION

**Requirement**

Right end of oscillating rail slide should clear edge of pulley

Min 0.025 inch---Max 0.050 inch

**To Check**

Locate spacing cut-out arm and automatic carriage return-line feed arm (if used) in maximum counterclockwise position on spacing drum. Spacing clutch disengaged. Feed pawl which is farthest advanced engaging tooth immediately above cutaway section of ratchet.

**To Adjust**

Position slide on wire rope with clamp screws loosened.

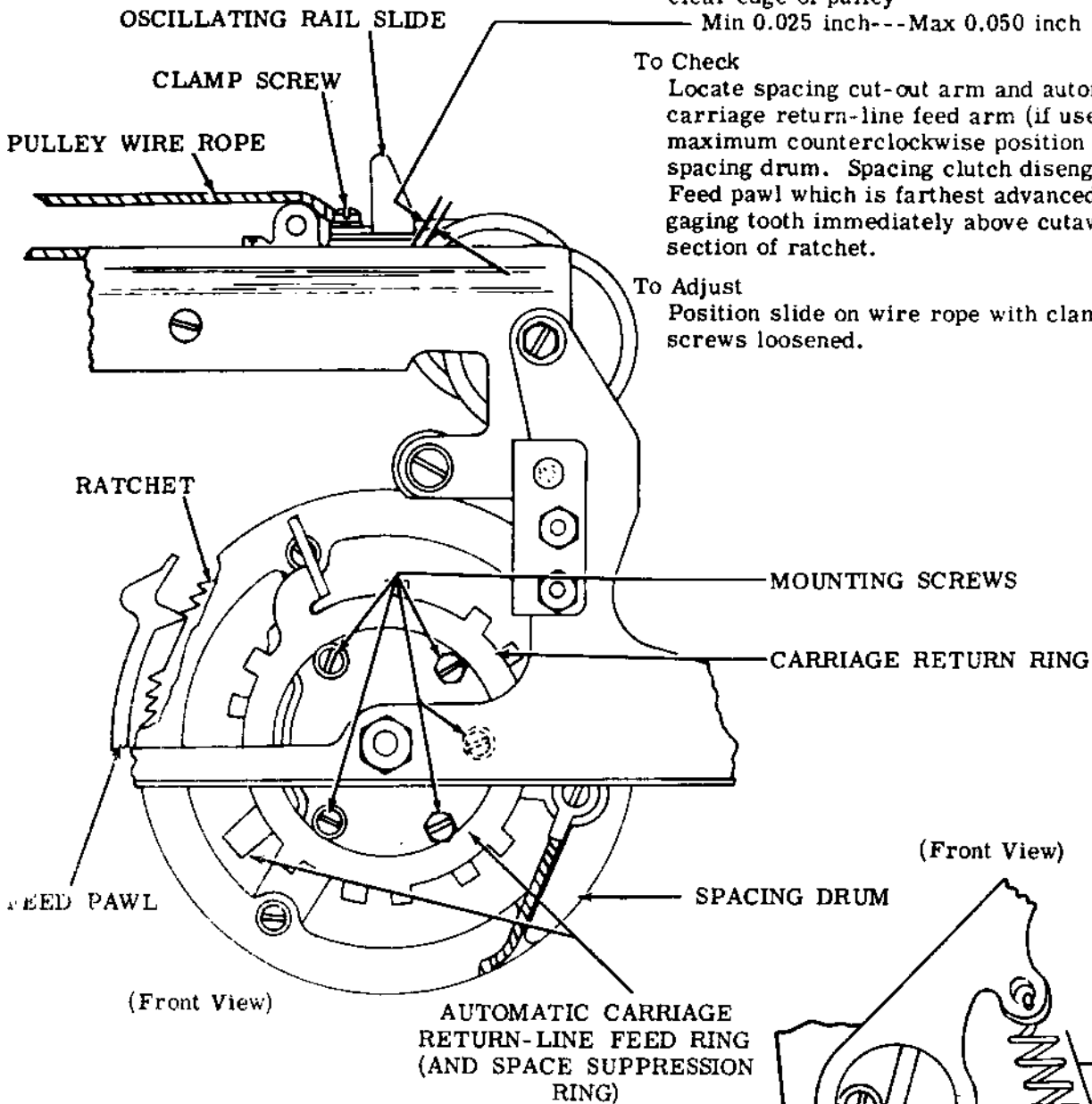

(Front View)

(Front View)

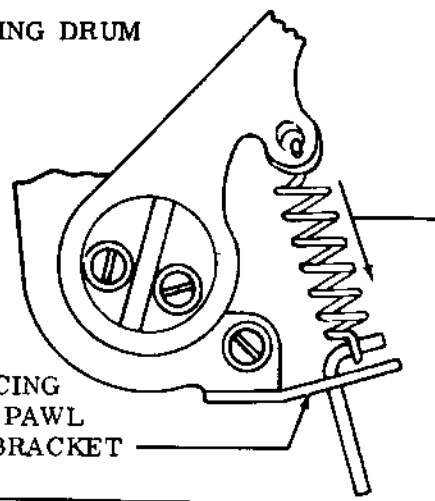

SPACING FEED PAWL SPRING

**Requirement**

Each spacing pawl in least advanced position resting against ratchet wheel. Each spring unhooked from bracket

Min 2-1/2 oz---Max 6 oz  
to pull springs to installed length.

**Note:** On units equipped for 5 or 6 spaces per inch the tension to pull each spring to installed length should be Min 7-1/2 oz---Max 11 oz.

2.45 Spacing Mechanism (continued)

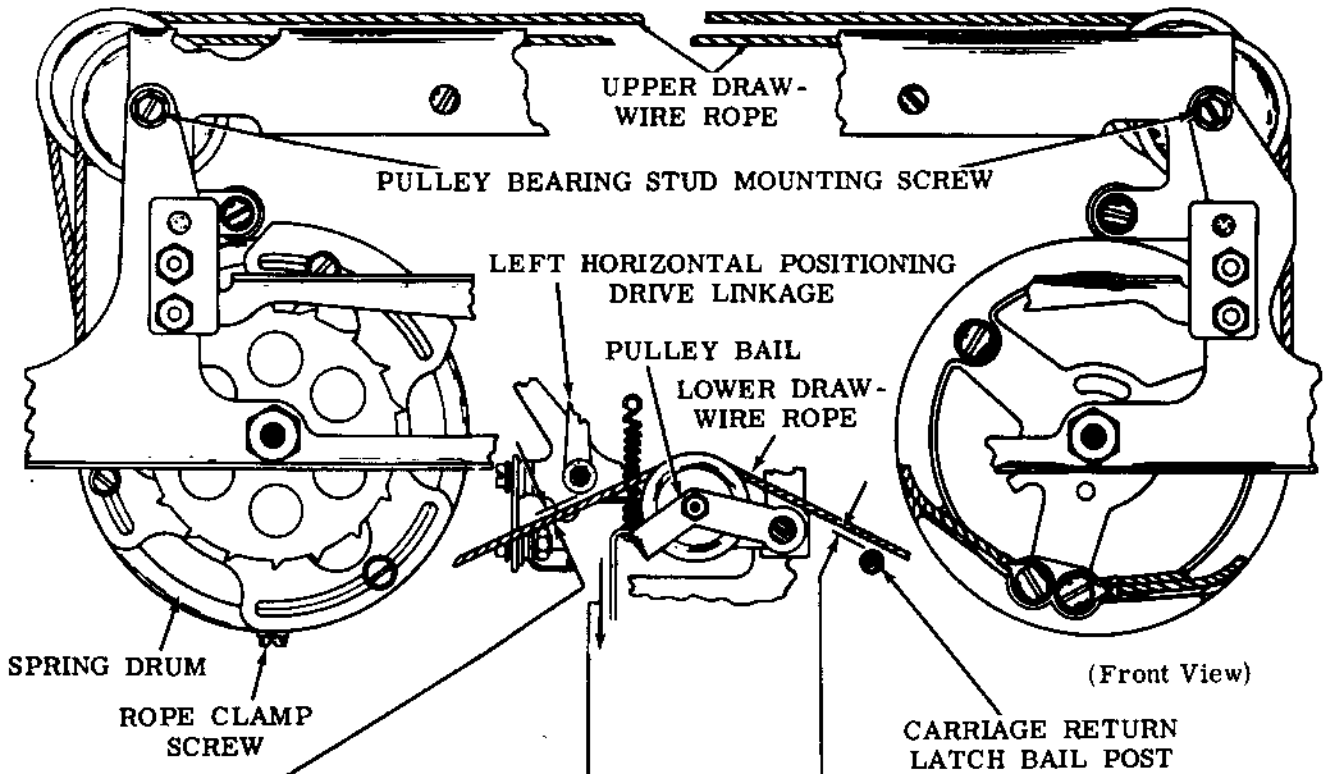

LOWER DRAW-WIRE ROPE PULLEY BAIL SPRING

**Requirement**

Spring unhooked from pulley bail, bail extension resting on opening in front plate.

Min 26 oz ---Max 30 oz  
to pull spring to position length.

CARRIAGE DRAW-WIRE ROPE

**Requirement**

Clearance between lower draw-wire rope and carriage return latch bail post should be

Min 0.006 inch

With the horizontal positioning mechanism in its lowest position, clearance between the lower draw-wire rope and the left horizontal positioning drive linkage should be

Min 0.030 inch

**To Adjust**

Advance printing carriage to extreme left hand position. Rotate typebox clutch 1/2 revolution. Loosen rope clamp screw one turn only. Position pulley bearing studs, with their mounting screws loosened, to meet requirement. Check that cable has moved around its equalizing clamp so that cables have equal tension (gauge by feel). Tighten clamp screw.

2.46 Spacing Mechanism (continued)

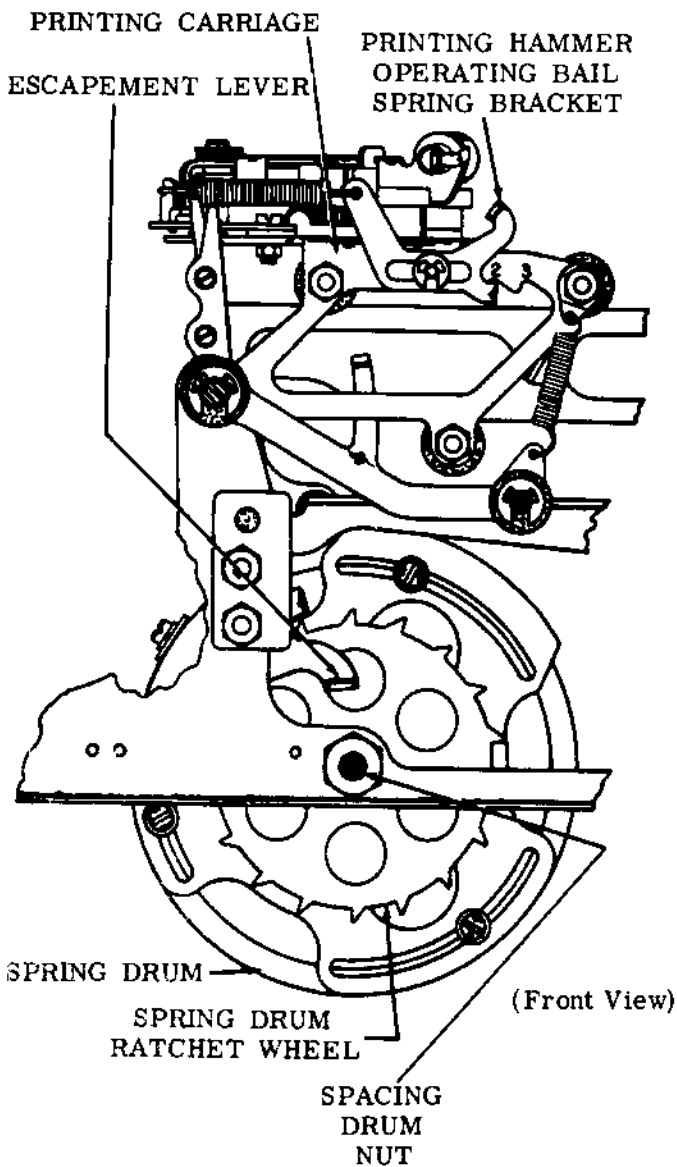

CARRIAGE RETURN SPRING

Requirement

Pull required to start drum moving  
 Min 3-1/2 lb---Max 4-1/4 lb

To Check

Spacing drum in returned position. Printing track in lowest position. Remove lower cable roller and print hammer carriage stabilizer springs. Hold spacing pawls, buffer slide, and carriage return latch to prevent interference with spacing drum.

To Adjust

Spring drum nut loosened. Rotate spring drum ratchet wheel to increase tension. Operate escapement lever to decrease tension.

Note: Keep spring tension at minimum for operation at altitudes higher than 2000 feet above sea level.

SPACING FEED PAWL RELEASE LINK SPRING

Requirement

Min 1/2 oz---Max 2-1/2 oz to start link moving.

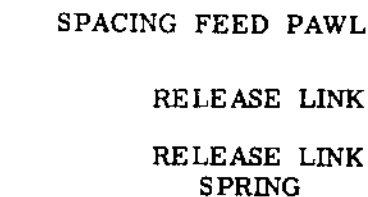

(Front View)

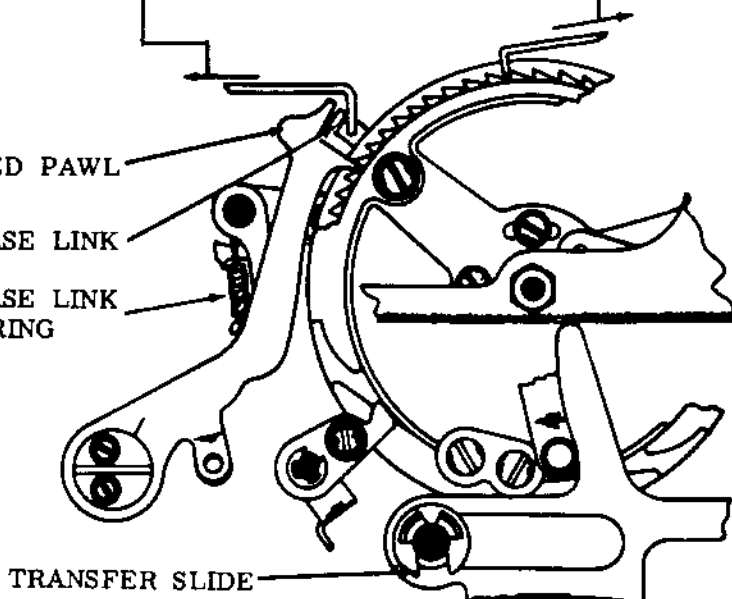



2.47 Printing Mechanism

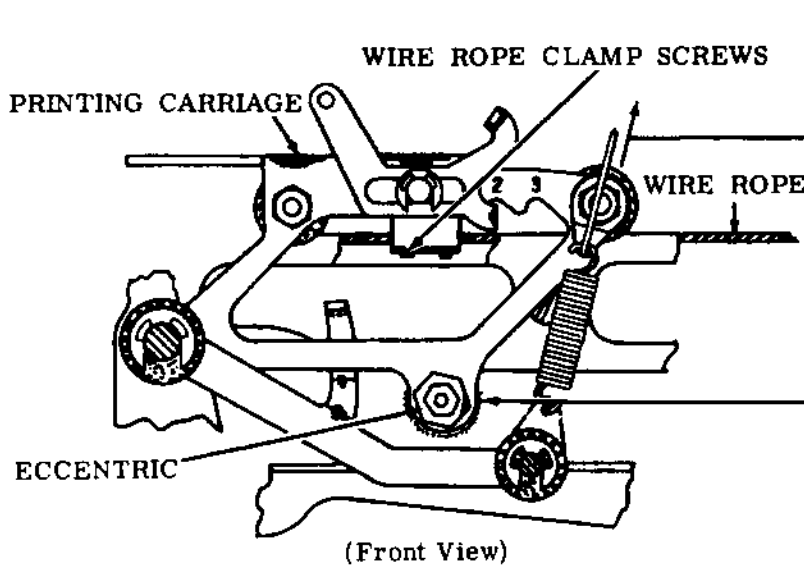

STABILIZING SPRING

Requirement  
Typebox clutch disengaged  
Min 5 oz---Max 8 oz  
to pull spring to installed  
length.

PRINTING CARRIAGE  
LOWER ROLLER

Requirement  
Carriage vertical play on track  
minimum without binding.

To Adjust  
Position eccentric of lower roller  
with screw nut loosened. Keep  
high part of eccentric (chamfered  
corner) toward right.

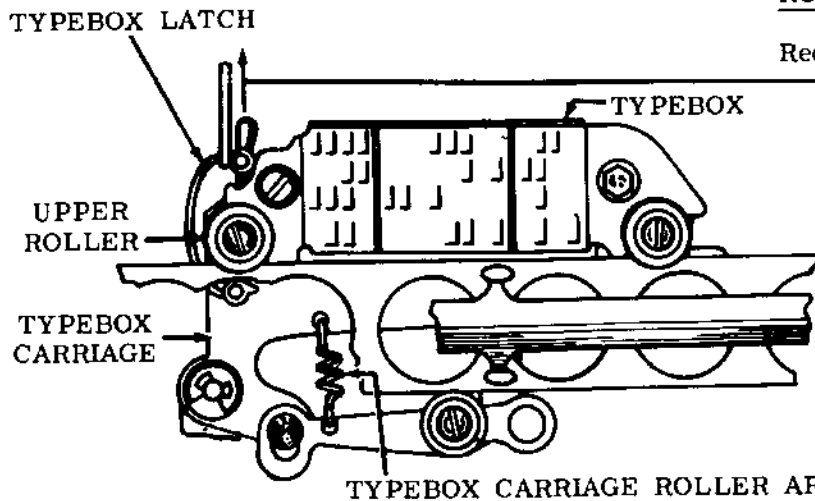

TYPEBOX CARRIAGE  
ROLLER ARM SPRING

Requirement  
Min 28 oz---Max 36 oz  
to start upper roller, nearest type-  
box latch, moving away from carriage  
track.

(Rear View)

2.48 Spacing Mechanism (continued)

CARRIAGE RETURN LATCH BAIL

Requirement

Carriage fully returned. Play in carriage return bail taken up to right by holding right side of bail against its retainer. Clearance between carriage return latch bail and carriage return lever

Min 0.004 inch---Max 0.040 inch

To Adjust

Position latch bail plate with clamp screw loosened.

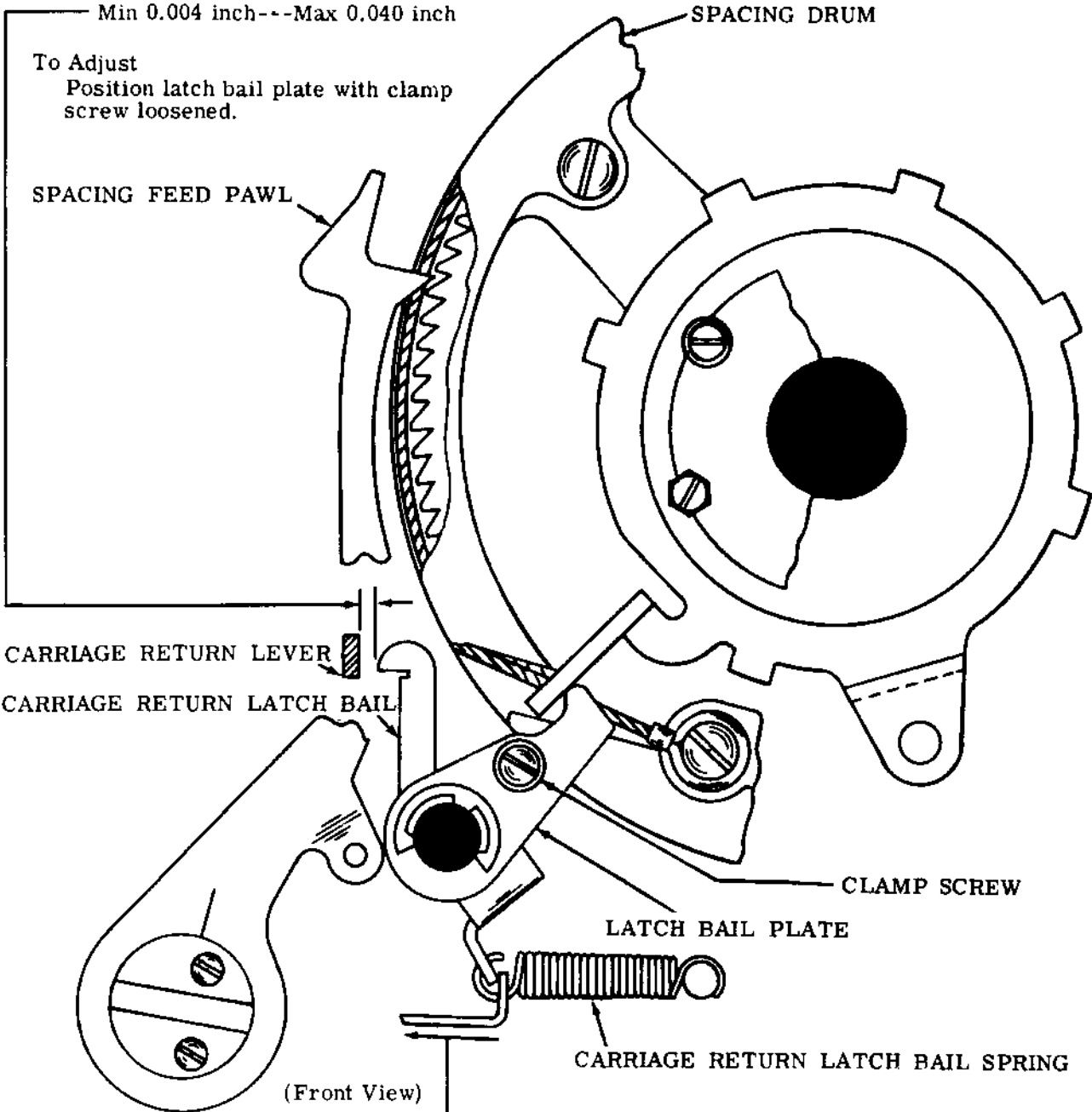

CARRIAGE RETURN LATCH BAIL SPRING

Requirement

Spacing drum fully returned  
Min 3 oz---Max 4-1/2 oz  
to start latch bail moving.

2.49 Spacing Mechanism (continued)

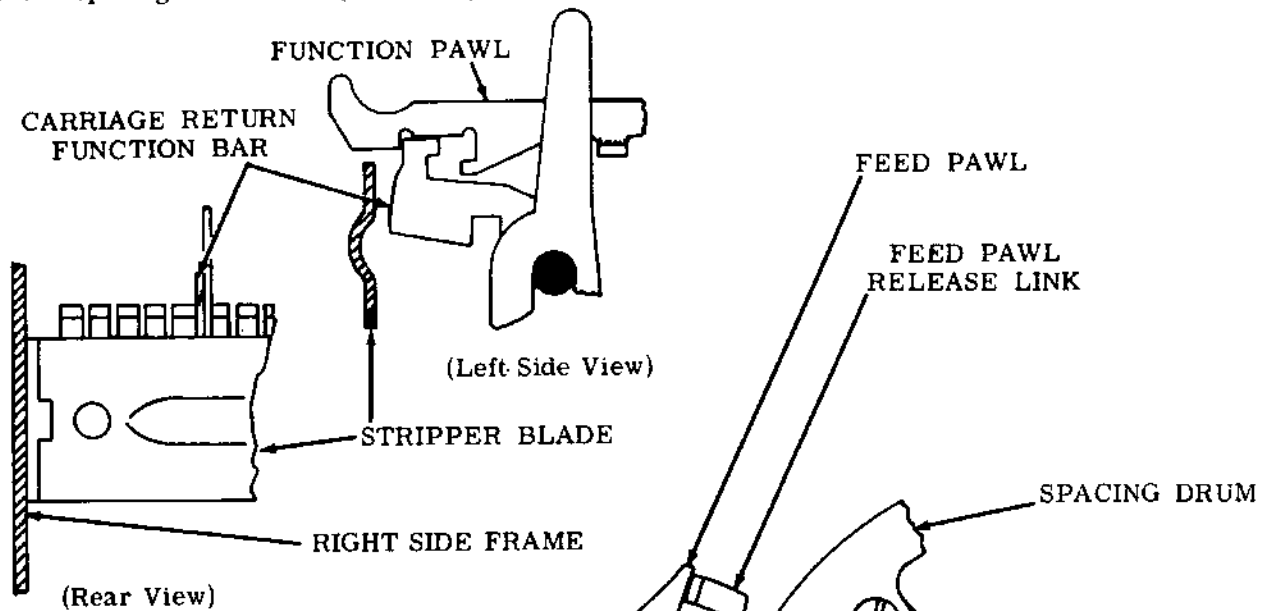

CARRIAGE RETURN LEVER

Requirement (Units Equipped with One-Stop Function Clutch)

Carriage return function set up on selector. Main shaft rotated until function clutch stop-lug is toward bottom of unit. Carriage return function pawl hooked over its function bar. Spacing drum held so that carriage return latch bail is latched. Clearance between latch bail and carriage return lever  
 Min 0.006 inch---Max 0.035 inch

To Adjust

Position carriage return lever on carriage return bail with clamp screw loosened.

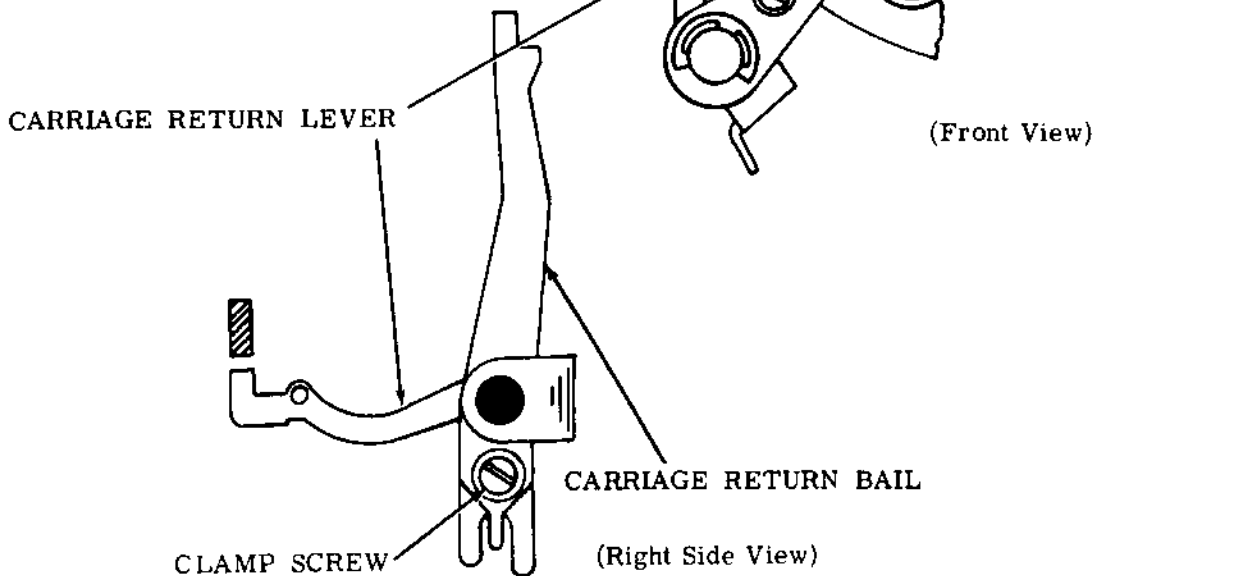

2.50 Spacing Mechanism (continued)

DASHPOT VENT SCREW

Requirement

Typebox carriage should return from any length of line without bouncing.

To Check

Printer operated at any speed from automatic transmission with one CR and one LF signal between lines. First character of each line should be printed in same location as if unit was manually operated slowly.

To Adjust

Turn down vent screw until slight pneumatic bounce is perceptible. Back off screw until effect disappears, then back screw off 1/4 turn. Tighten nut.

Note: It may also be necessary to reduce tension shown in CARRIAGE RETURN SPRING (2.46) adjustment to minimum for operation at altitudes higher than 2000 feet above sea level.

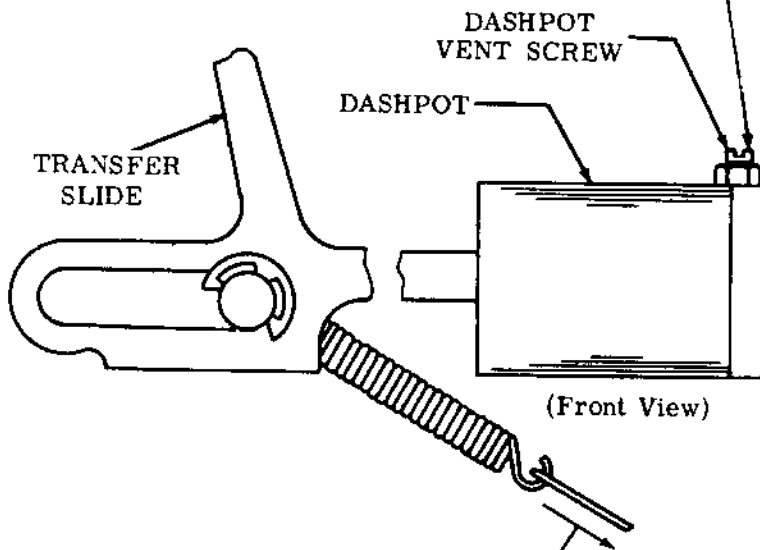

TRANSFER SLIDE SPRING

Requirement

Transfer slide in extreme left position. Spring unhooked.

Min 3-1/2 oz---Max 4-1/2 oz to pull spring to installed length.

2.51 Printing Mechanism (continued)

Note: Check related adjustments (2.44, 2.46, and 2.56), if the following adjustments are remade.

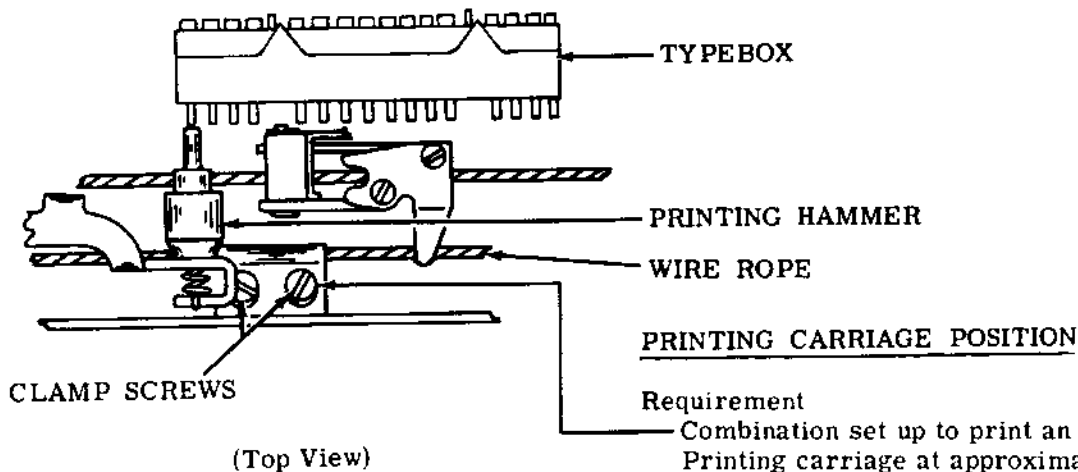

(Top View)

Requirement

Combination set up to print an apostrophe. Printing carriage at approximate midpoint of track. Rotate printer shaft so typebox is in printing position. Proper type pallet should be approximately in center of printing hammer.

To Adjust

Position printing carriage on wire rope with clamp screw loosened.

Note: Take up play in typebox carriage alternately in each direction. Secure carriage at point where print hammer is approximately center of play.

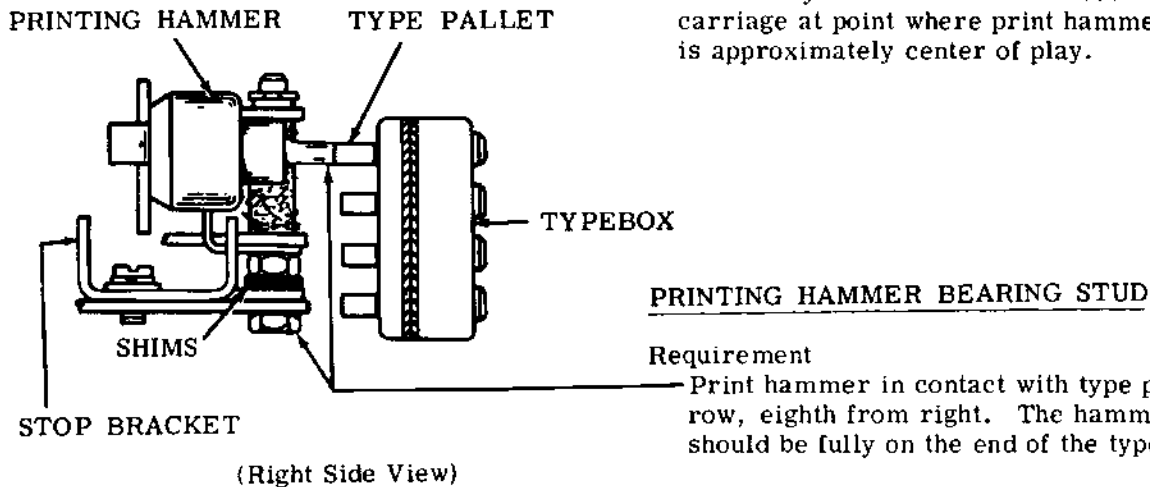

(Right Side View)

Requirement

Print hammer in contact with type pallet in top row, eighth from right. The hammer face should be fully on the end of the type pallet.

To Adjust

Add or remove shims between shoulder on bearing post and stop bracket. When checking, take up play in hammer operating bail downward on post.

2.52 Positioning Mechanism (continued)

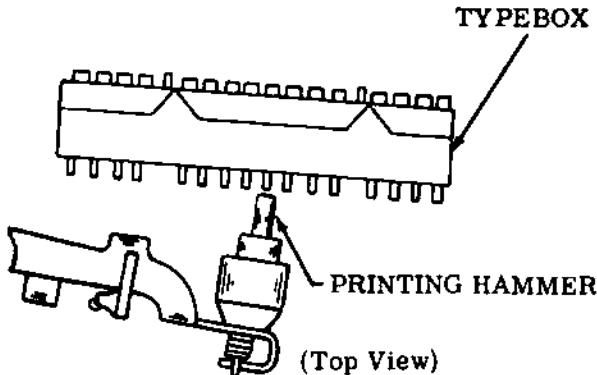

(A) SHIFT LINKAGE (FINAL)

Requirement

Typebox in position to print eighth character from right in the top row at midpoint of platen. Proper type pallet should align with print hammer.

To Adjust

Position oscillator left hand shift link bracket with two clamp screws loosened. With printer operating alternate characters (& and C), refine adjustment for correct alignment if necessary.

Note: Take up typebox carriage play in both directions and set print hammer to approximate center of play, as gauged by eye.

Do not disturb preliminary adjustment (2.39).

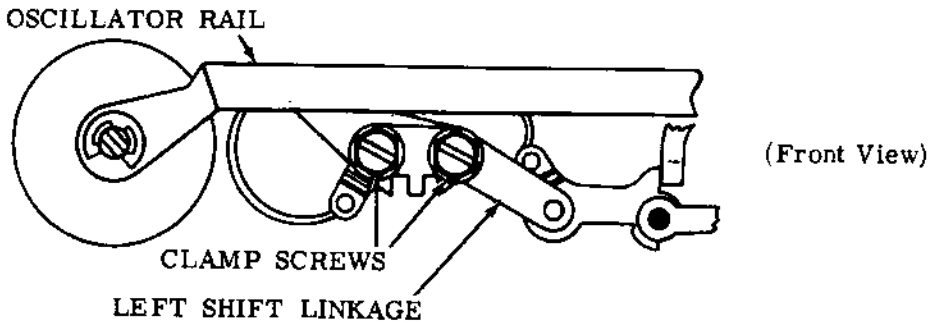

(Front View)

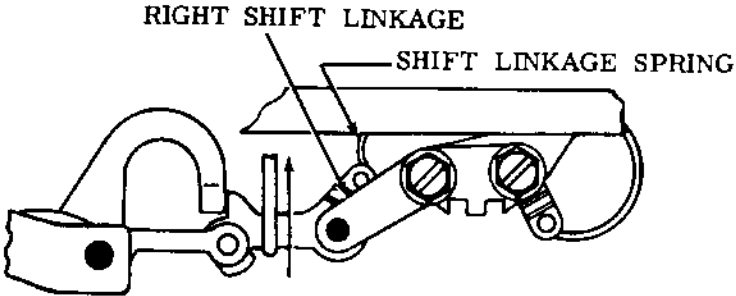

(B) SHIFT LINKAGE SPRING

Requirement

Link in straight position  
Min 6 oz---Max 14 oz  
to start each link moving.  
Measure both right and left links.

2.53 Printing Mechanism (continued)

(A) PRINTING TRACK

Requirement

Printing track in its extreme downward position. Extreme right hand character selected. Printing hammer operating bail latching extension held with left face in line with the latch shoulder. Printing arm slide positioned alternately over each track mounting screw. Printing bail reset each time. Clearance between latching extension and operating bail latch should be

Min 0.015 inch---Max 0.040 inch

To Adjust

Position the printing track up or down with its mounting screws loosened. Hold clearance to maximum.

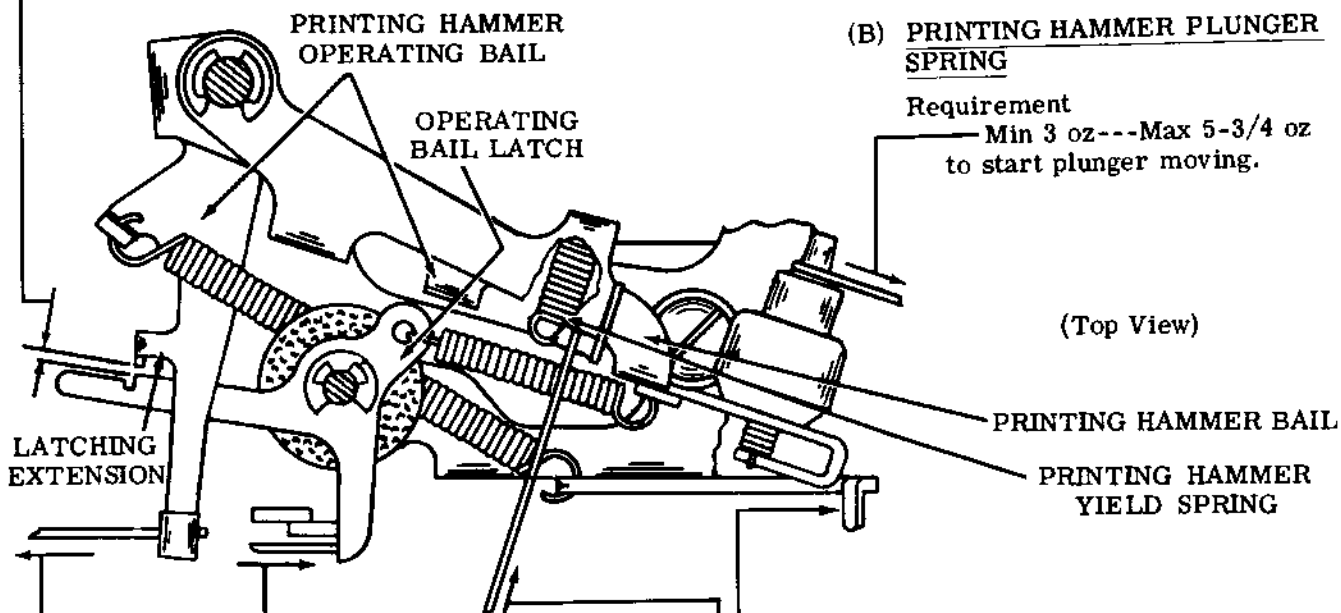

(B) PRINTING HAMMER PLUNGER SPRING

Requirement

Min 3 oz---Max 5-3/4 oz to start plunger moving.

(Top View)

(E) PRINTING HAMMER OPERATING BAIL LATCH SPRING (Not as Illustrated)

Requirement

Printing track in its extreme upward position

Min 3 oz---Max 4-1/2 oz to start latch moving.

(C) PRINTING HAMMER OPERATING BAIL SPRING

Requirement

Use notch no. 1 for printing one to three copies, no. 2 for four or five copies, and no. 3 for six or more copies.

To Adjust

Position spring adjusting bracket in required notch.

(F) PRINTING HAMMER OPERATING BAIL SPRING (Not as Illustrated)

Requirement

Operating bail latched. Spring adjusting bracket in left hand (no. 1) notch. Hammer yield spring unhooked

Min 10 oz---Max 13 oz to start bail moving.

(D) PRINTING HAMMER YIELD SPRING

Requirement

Printing hammer operating bail against its stop

Min 1 oz---Max 2-1/2 oz to start hammer bail moving (horizontal position).

2.54 Printing Mechanism (continued)

PRINTING HAMMER STOP BRACKET

**Requirement**

With print hammer in upper left typebox position and printing bail in its maximum downward position, there should be

Min 0.005 inch---Max 0.050 inch clearance between print hammer and type pallet at any point along length of platen.

Note: Refine this adjustment to 0.005 to 0.015 inch on sprocket feed printer, if necessary to improve copy legibility on multiple forms.

**To Adjust**

Position stop bracket by means of its two mounting screws.

Note: The printing hammer operating bail spring bracket positions no. 2 and 3 are to be used only for making multiple copies.

TYPE PALLET SPRING

**Requirement**

Typebox removed from the unit. 8 oz scale applied vertically to the end of the pallet shank.

Min 1/4 oz---Max 3/4 oz to start pallet moving.

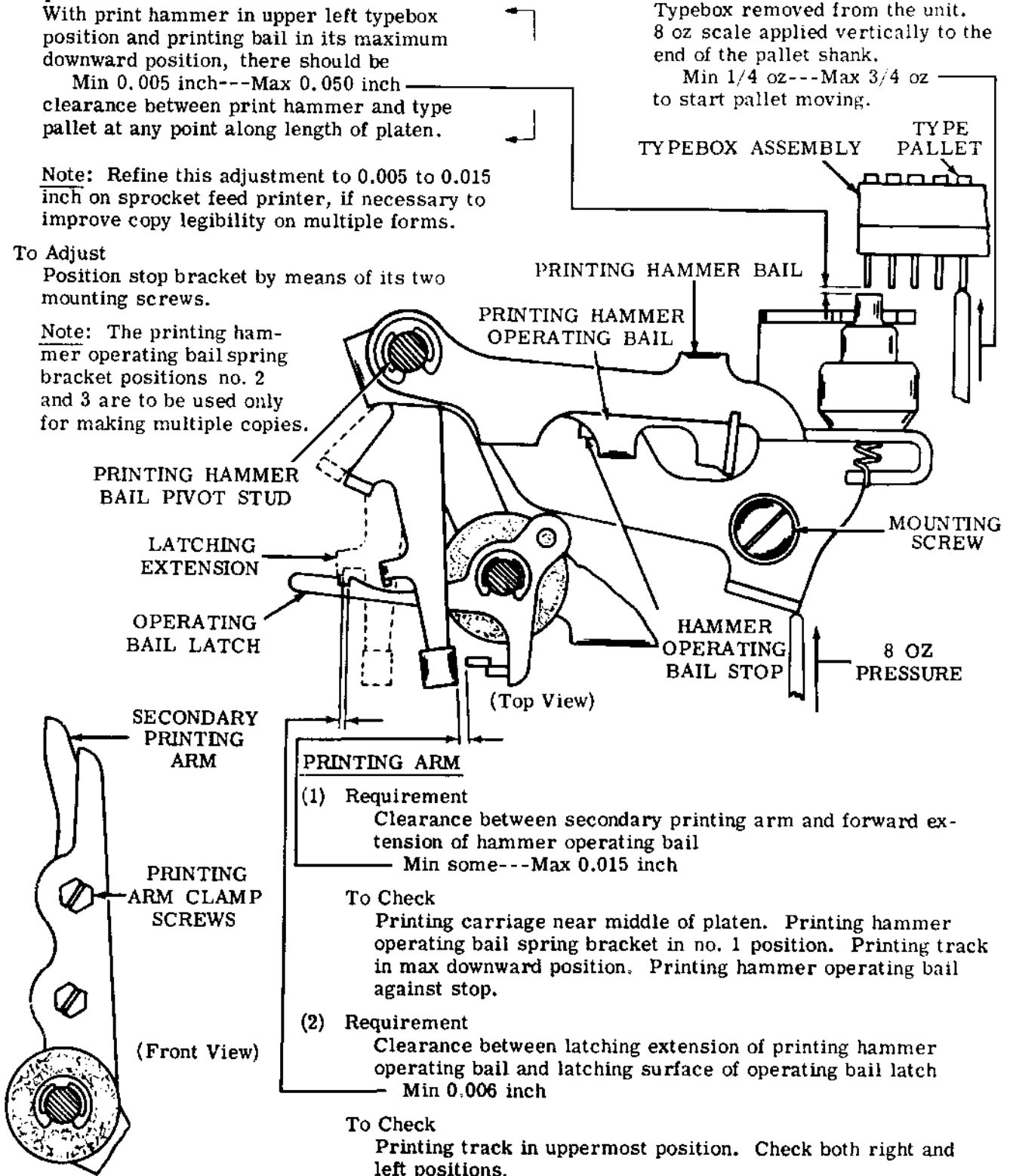

**To Adjust**

Position secondary printing arm with clamp screws loosened.



2.55 Spacing Mechanism (continued)

**Note 1:** Check related adjustments (2.44, 2.48, and 2.56), if the following adjustments are remade.

**Note 2:** For sprocket feed units see 2.76 thru 2.82.

**LEFT MARGIN**

(1) Requirement (72 Character Line)

Typebox clutch disengaged. Spacing drum in returned position. Clearance between left edge of platen and print indicator located in front of printing hammer stop bracket

Min 15/16 inch---Max 1-1/16 inch

(In Bell System Switched-Network Services

Min 9/16 inch---Max 11/16 inch)

**AUTOMATIC CR-LF BELLCRANK SPRING**  
(For Units So Equipped)

Requirement

Function clutch disengaged.

Min 2-1/2 oz---Max 7 oz  
to move the bellcrank.

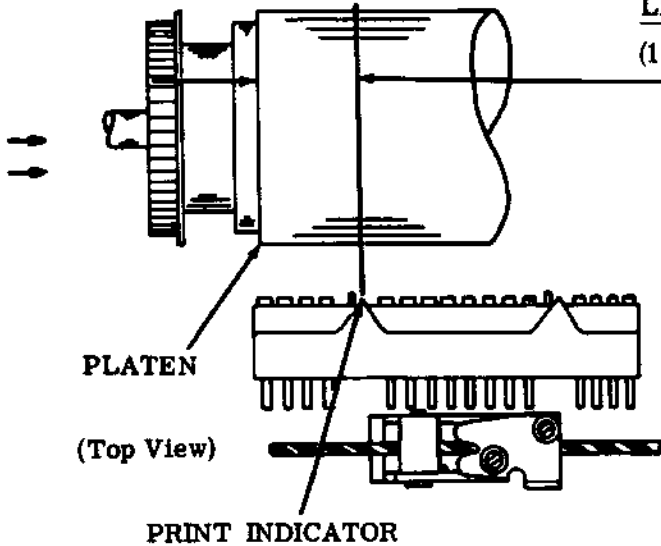

PLATEN

(Top View)

PRINT INDICATOR

(2) Requirement

Spacing clutch disengaged. Front spacing feed pawl farthest advanced. Spacing drum fully returned. Play in spacing shaft gear (2.29) taken up clockwise. Clearance between pawl and shoulder of ratchet wheel tooth immediately ahead

Min some---Max 0.008 inch

(3) Requirement

Rear pawl, when farthest advanced, should rest at bottom of indentation between ratchet wheel teeth.

To Adjust

Return print carriage to its left position. Loosen four indicated carriage return ring mounting screws. Hold carriage return ring in its counterclockwise position. Locate typebox so that print indicator which is in front of printing hammer stop bracket is in required position. Tighten four mounting screws.

FEED PAWLS

AUTOMATIC CR-LF BELLCRANK

MOUNTING SCREWS

CARRIAGE RETURN RING

SPACING DRUM RATCHET WHEEL

(This view shows the spacing drum fully returned.)

(Front View)

**Note 3:** The left margin may be varied as required. Maximum range of adjustment for mechanisms with standard 10 characters per inch spacing is: friction feed platen 85 characters and sprocket feed platen 74 characters.

## 2.56 Spacing Mechanism (continued)

Note 1: Check related adjustments (2.36, 2.55, and 2.48), if the following adjustments are remade.

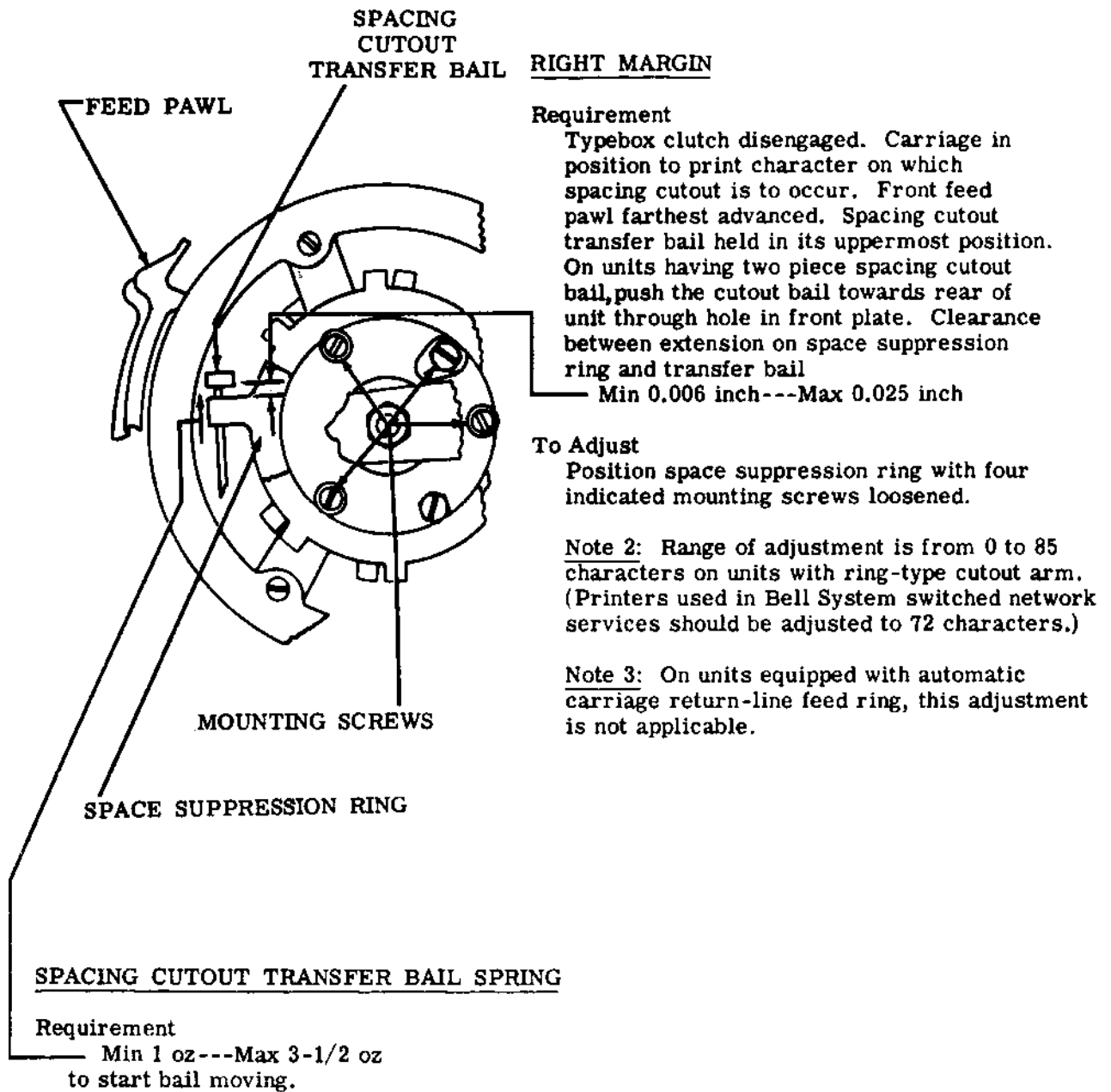
SPACE SUPPRESSION BYPASS SPRING (On Unit Equipped With Separate Cutout Lever and Spring)**Requirement**

With typing unit upside down, hook a scale on the spacing cutout lever extension pawl next to the spring and pull towards the rear of the unit.

Min 20 oz---Max 26 oz  
to start the pawl moving.

2.57 Printing Mechanism (continued)

TYPEBOX ALIGNMENT

Requirement

Printed impression of characters at top and at bottom should be equal (gauge visually).

To Adjust

Loosen nut. Operate printer under power. Repeat characters E and Z. Turn adjusting screw in or out (in steps of 1/4 turn) to meet requirement. Tighten nut.

Note: Check and refine PRINTING HAMMER STOP BRACKET (2.54) if necessary.

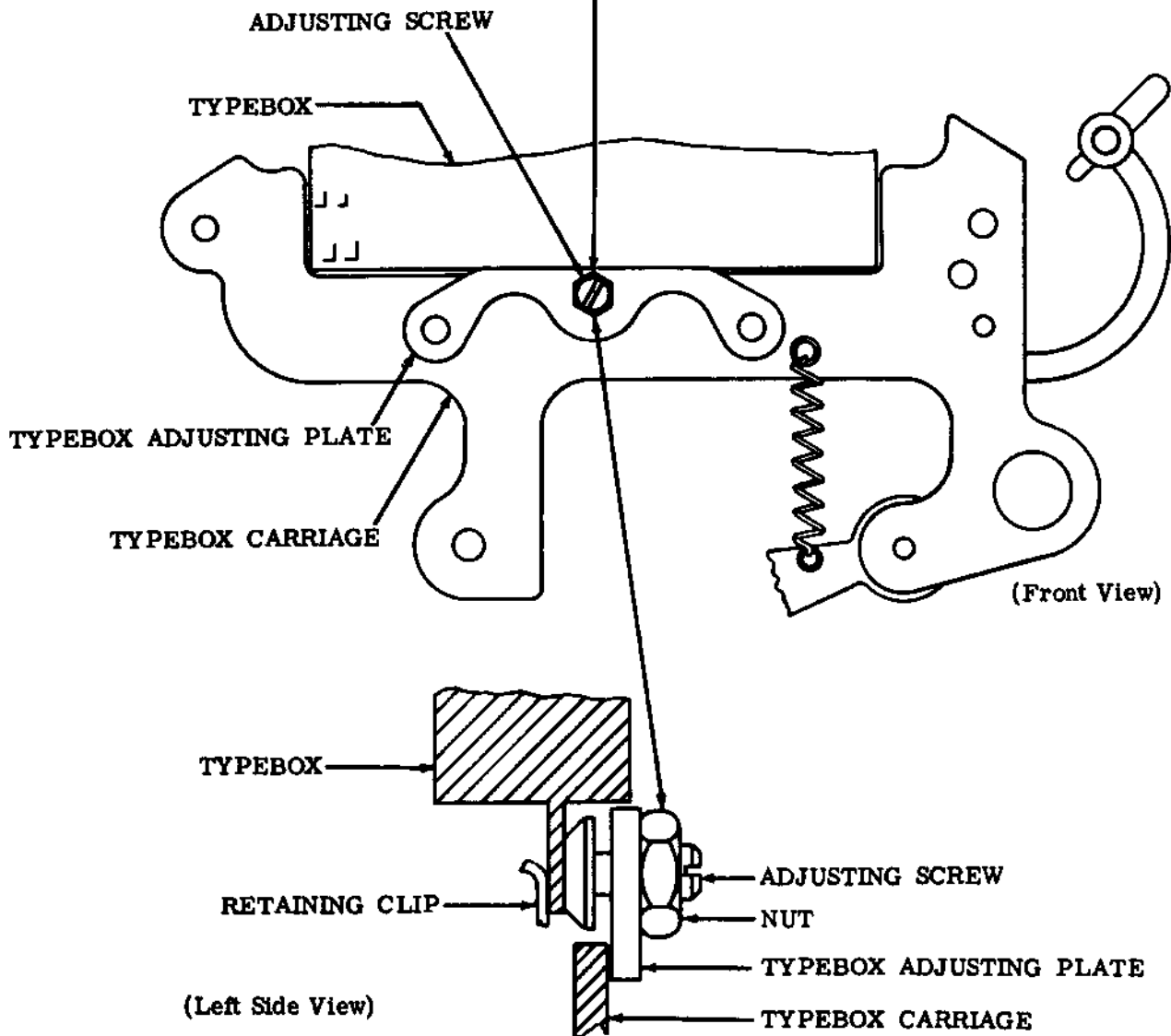

2.58 Printing Mechanism (continued)

**(A) RIBBON REVERSE SPUR GEAR**

**Requirement**

When right reversing lever is in max downward position, the left reversing lever should be in its max upward position.

**To Adjust**

Loosen the setscrews in the detent cam. Loosen the left spur gear nut. Securely tighten the right spur gear nut. Move the right reversing lever to its max upward position and hold the left reversing lever in its max downward position. Then tighten the left spur gear nut.

**Note:** Rotate typebox clutch 1/2 turn. Right reversing lever upward. Move right ribbon lever under right ribbon reversing lever. There should be some clearance between levers. Check left side same way. Refine adjustment if necessary.

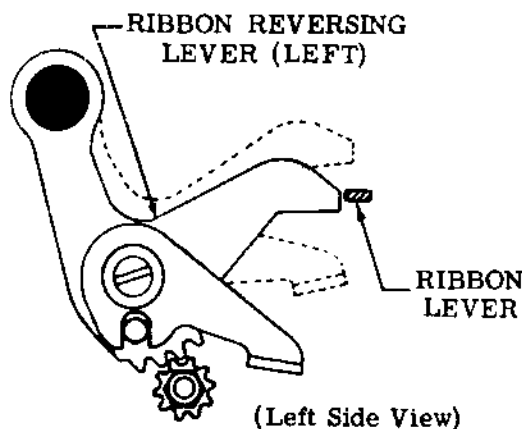
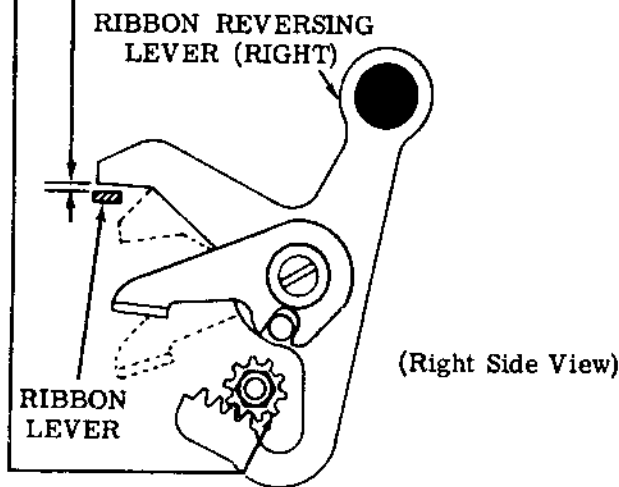

**(B) RIBBON REVERSE DETENT**

**Requirement**

Ribbon reverse detent link buckled in its downward position, clearance between detent link and detent lever

Min some---Max 0.055 inch when play in the lever is taken up lightly toward the right side of the printer.

**To Adjust**

Hold left ribbon reversing lever in its downward position, position detent link, and tighten the upper setscrew in the hub of the detent link. Buckle the detent link upward and tighten lower setscrew.

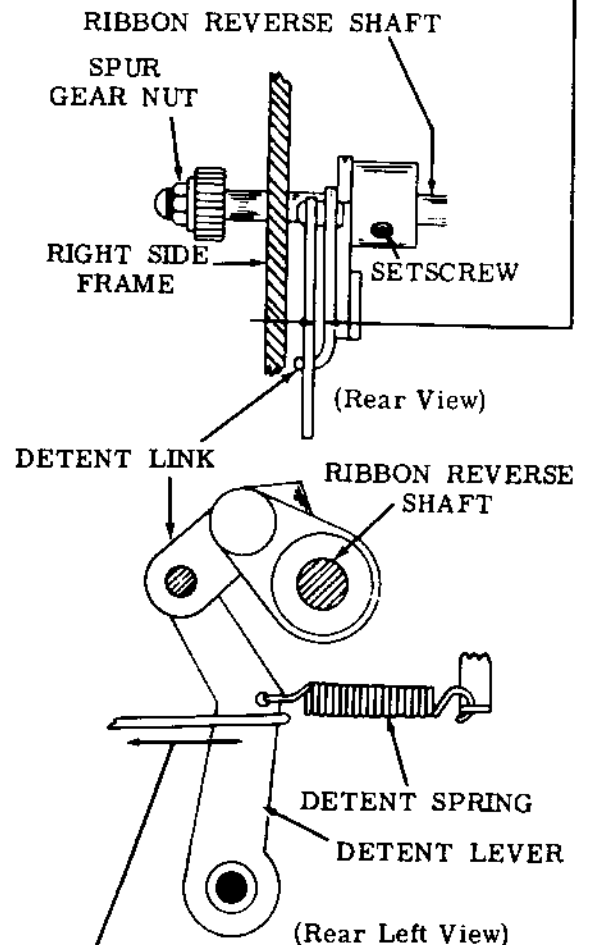

**(C) RIBBON REVERSE DETENT LEVER SPRING**

**Requirement**

Detent link buckled in upward position  
Min 10 oz---Max 18 oz to start detent lever moving toward rear.

2.59 Printing Mechanism (continued)

RIBBON FEED LEVER BRACKET

(1) Requirement (Left-Hand Mechanism)

Left reversing lever in upward position. Ribbon mechanism in upper position. Ratchet wheel held against the detent lever. Clearance between the front face of the feed lever and the shoulder of a tooth on the ratchet wheel

Min 0.015 inch---Max 0.035 inch

(2) Requirement (Right-Hand Mechanism)

Right reversing lever and ribbon mechanism in upward position. Adjust feed lever bracket in the same manner.

Note 1: Rotate the main shaft. The ratchet wheel should step one tooth only with each operation.

To Adjust

Position the feed lever bracket with its mounting screws loosened.

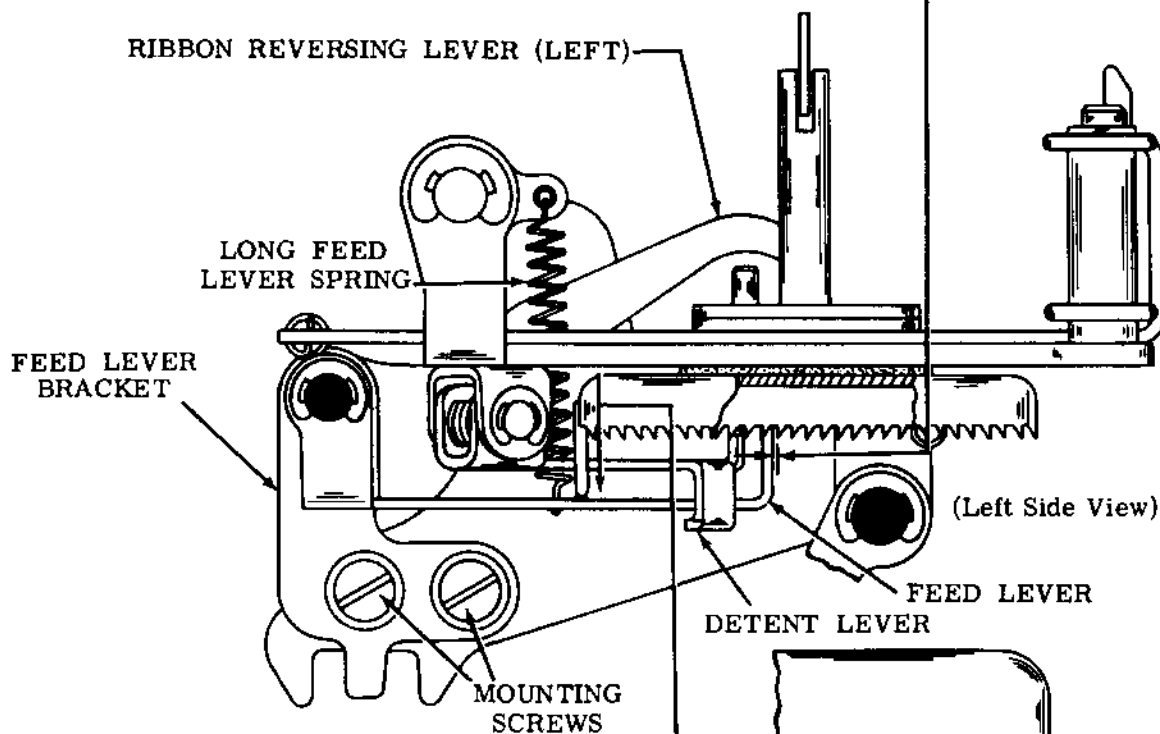

RIBBON FEED LEVER SPRING

Requirement

Ribbon feed levers in uppermost position. For Long Lever: Push downward near its spring. For Short Lever: Push downward at point near long lever spring.

Min 3/4 oz---Max 2 oz to start feed levers moving. Measure all four levers.

Note 2: If minimum requirement of short lever is not met, pull lower end of torsion spring to rear.

RIBBON RATCHET WHEEL FRICTION SPRING

Requirement

Feed levers disengaged. Min 3 oz---Max 8-1/2 oz to start the ratchet wheel moving.

2.60 Printing Mechanism (continued)

RIBBON LEVER SPRING

Requirement

Min 1-1/2 oz---Max 3 oz  
to start the lever moving. Check both  
right and left springs.

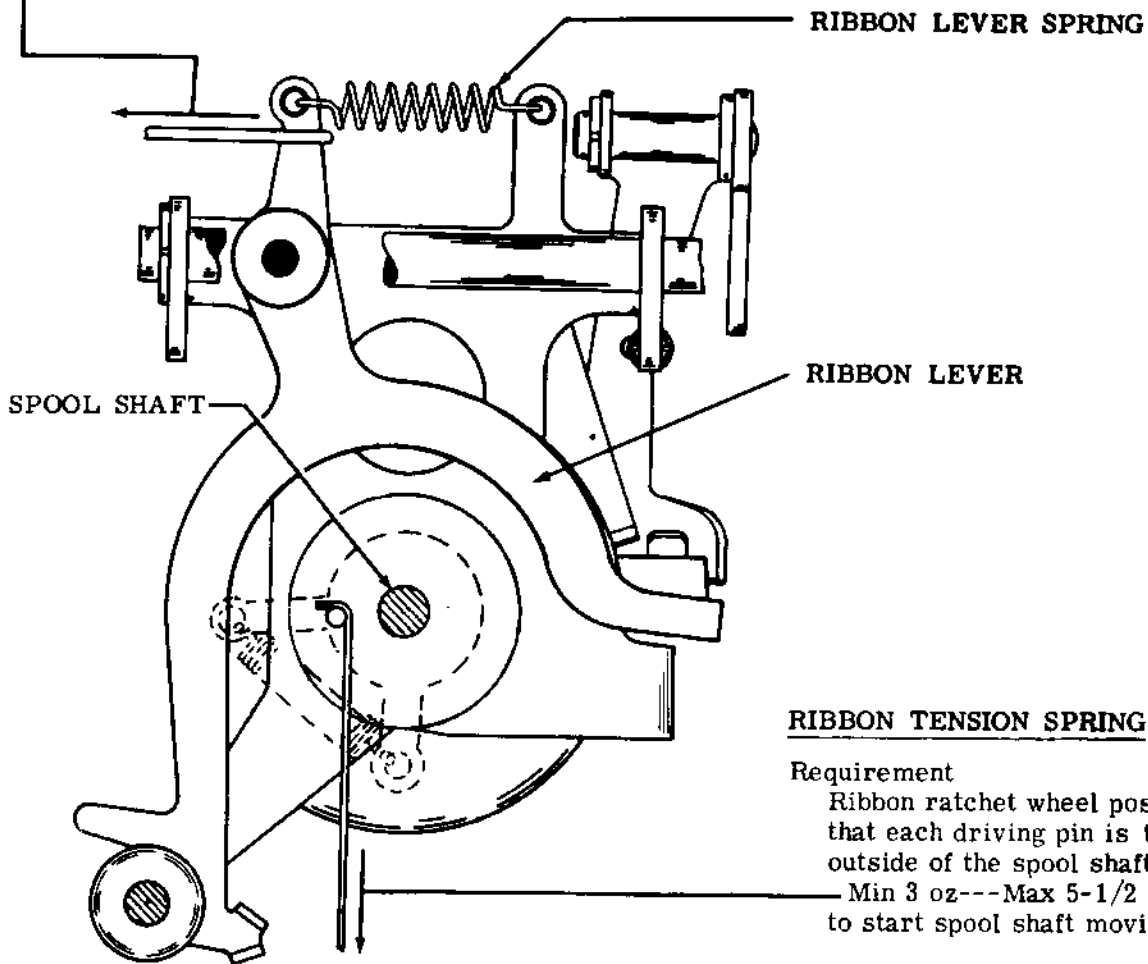

(Top View)

RIBBON TENSION SPRING

Requirement

Ribbon ratchet wheel positioned so  
that each driving pin is toward the  
outside of the spool shaft.

Min 3 oz---Max 5-1/2 oz  
to start spool shaft moving.

2.61 Line Feed and Platen Mechanism (continued)

(B) PLATEN DETENT BAIL SPRING

Requirement

Detent seated between two teeth on line feed spur gear.  
 Min 16 oz---Max 32 oz to start detent bail moving.

(C) LINE FEED BAR RELEASE LEVER SPRING

Requirement

Min 3 oz---Max 8 oz to start lever moving.

(A) LINE FEED SPUR GEAR DETENT ECCENTRIC

Requirement

Line feed clutch disengaged. Platen rotated until detent stud is seated between two teeth on line feed spur gear. When hand wheel is released, manually set the teeth on the line feed bars into engagement with the teeth on the line feed spur gear. The detent stud should contact one gear tooth and be not more than 0.010 inch from other tooth.

To Adjust

Rotate the detent eccentric with its mounting screw loosened. Keep high part of eccentric upward.

(D) LINE FEED BAR BELLCRANK SPRING (FRICTION FEED)

Requirement

Left-hand line feed bar in rear position  
 Min 19 oz---Max 24 oz to start bar moving.

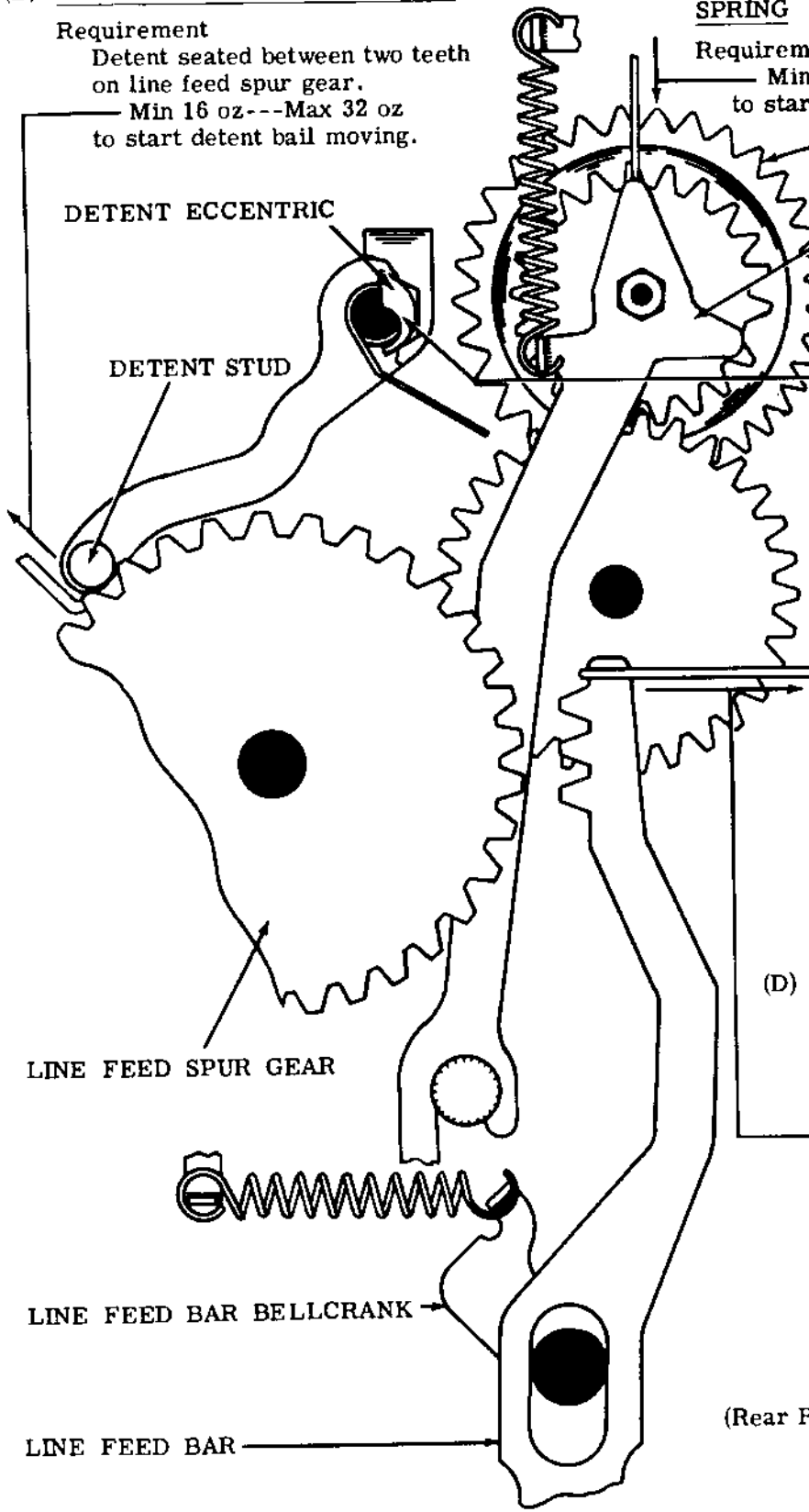

(Rear Right View)

## 2.62 Line Feed and Platen Mechanism (continued)

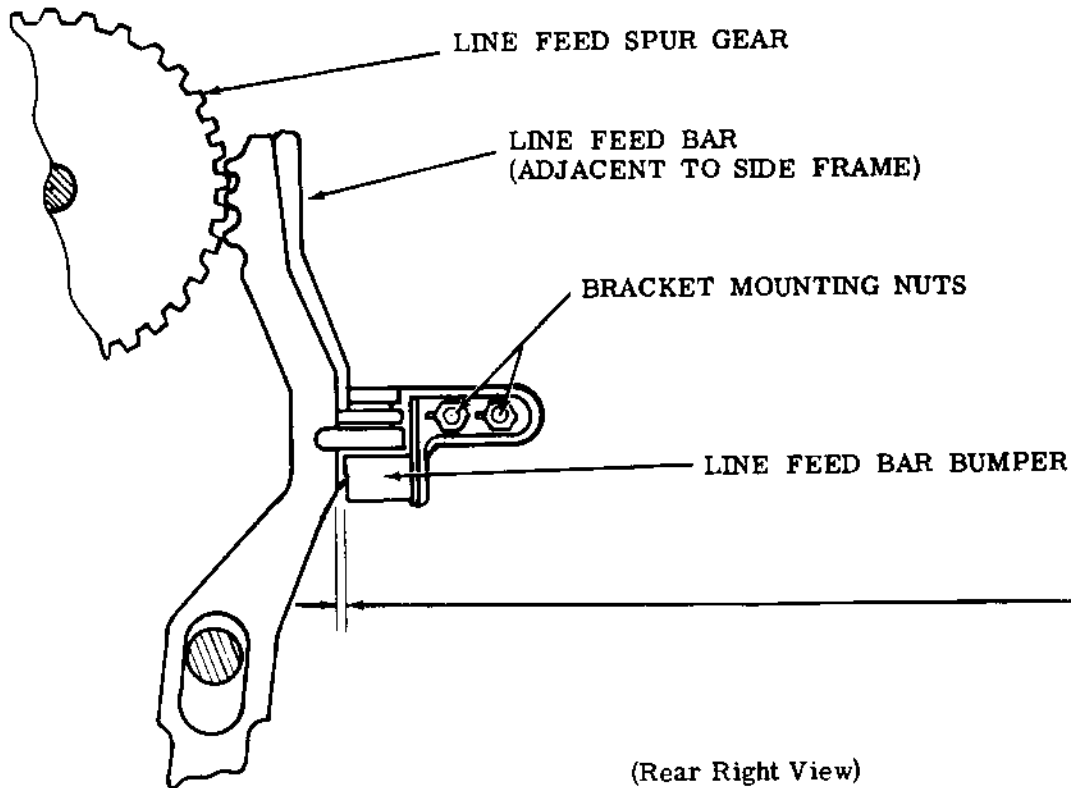
LINE FEED BAR BUMPER (SIX STOP CLUTCH ONLY)**Requirement**

With the line feed clutch tripped manually, rotate the main shaft until the line feed bar adjacent to side frame is at its maximum travel away from the line feed spur.

Min 0.065 inch---Max 0.080 inch  
clearance between the other line feed bar and the line feed bar bumper.

**To Adjust**

Loosen the two bracket mounting nuts and position the bracket thru its elongated slots until proper clearance is obtained. Then tighten the two mounting nuts.

Note: Recheck vertical tab or form-out adjustment (variable features).



2.63 Function Mechanism (continued)

STRIPPER BLADE DRIVE CAM POSITION

**Requirement**

Stripper blade drive cam should move each stripper blade cam arm on equal distance above and below center line of its pivot (gauge by eye).

- (a) Upward direction
- (b) Downward direction

**To Check**

With function clutch disengaged observe engagement of stripper blade drive cam (upper peak) with stripper blade cam arm. Then rotate clutch to turn cam to its extreme downward position and observe engagement of lower cam peak.

**To Adjust**

With stripper blade drive arm mounting screws loosened. Equalize the overtravel of each cam peak.

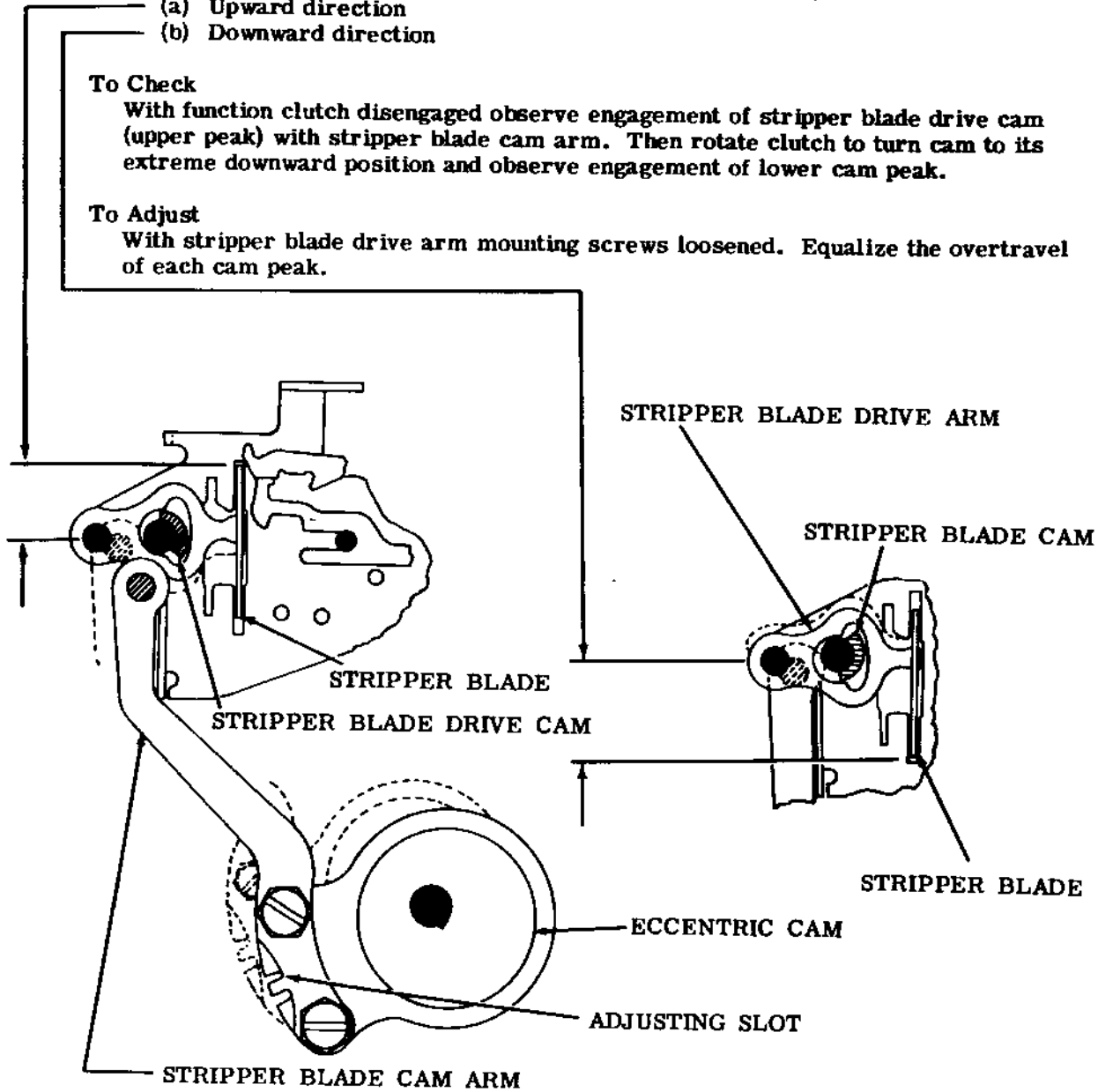

(Rear View)

2.64 Function Mechanism (continued)

(A) FUNCTION LEVER SPRING

**Note:** If a function lever operates a contact or a slide, hold off the contact or slide when checking the spring.

**Requirement**

Function lever in unoperated position. Suppression bail held forward.

Min 1-1/2 oz---Max 2-3/4 oz to start function lever moving. Check each spring.

(B) FUNCTION PAWL SPRING

**Requirement**

Rear end of function pawl resting on function bar

Min 3 oz---Max 5 oz to start pawl moving. Check each spring.

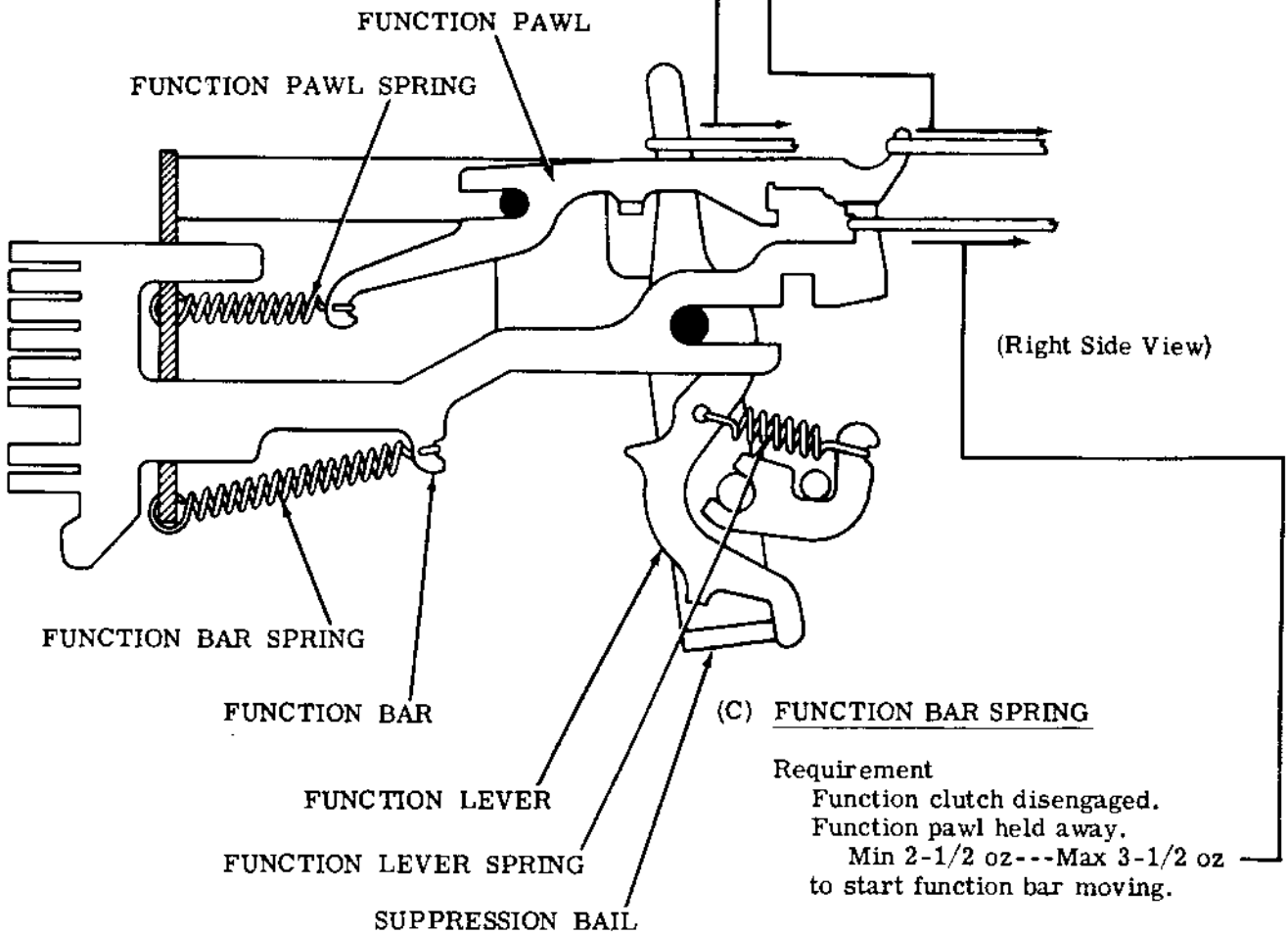

**CAUTION:** SEVERE WEAR TO THE POINT OF OPERATION FAILURE WILL RESULT IF THE TELETYPEWRITER IS OPERATED WITHOUT EACH FUNCTION PAWL HAVING EITHER A RELATED FUNCTION BAR OR, WHERE A FUNCTION BAR IS MISSING, A RELATED FUNCTION PAWL CLIP TO HOLD THE FUNCTION PAWL AWAY FROM THE STRIPPER BLADE.

2.65 Function Mechanism (continued)

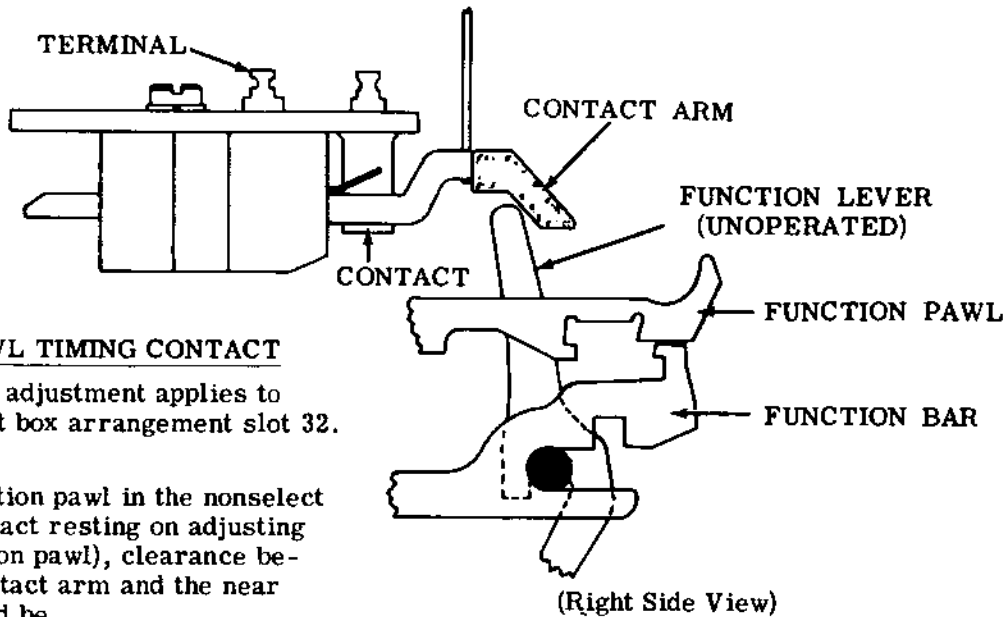

FUNCTION PAWL TIMING CONTACT

Note 1: This adjustment applies to the ATX stunt box arrangement slot 32.

**Requirement**

With the function pawl in the nonselect position (contact resting on adjusting stud of function pawl), clearance between the contact arm and the rear contact should be

Min 0.005 inch---Max 0.015 inch

**To Adjust**

Position adjusting stud by means of its mounting screw.

FUNCTION CONTACT SPRING

**Requirement**

Contact closed  
Min 1 oz---Max 2 oz  
to open switch contact.

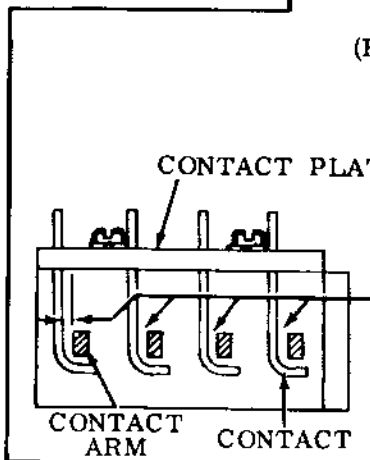
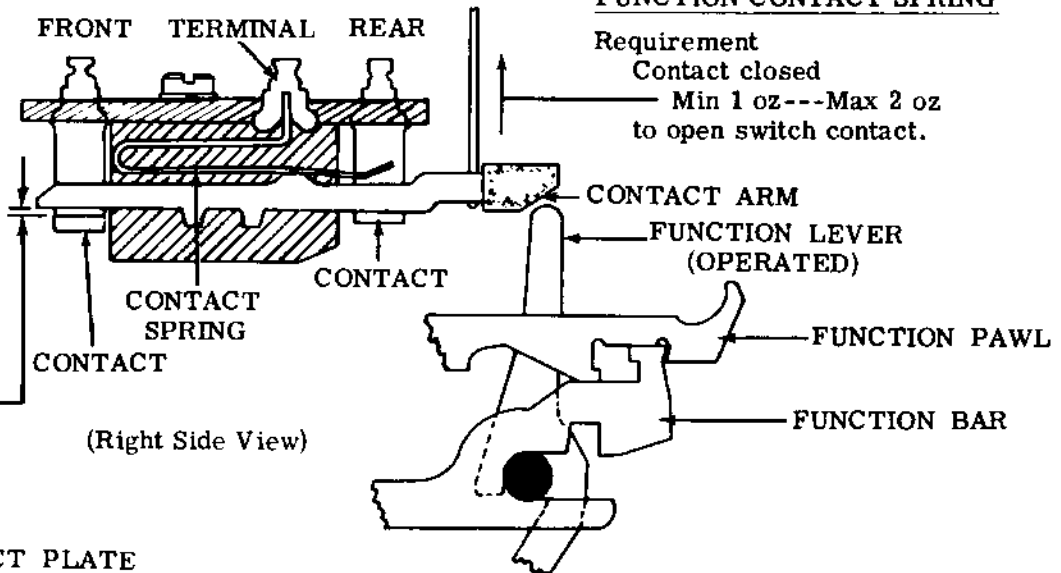

Note 2: If the switches are removed from the stunt box, the following requirements apply.

Provide at least 0.006 inch clearance between the contact arm and the vertical portion of the contact clip. If the switch has contacts front and rear, this clearance applies to both front and rear. To obtain this clearance, position the contact plate before tightening the contact plate screws.

On switches with contacts front and rear, check to see that there is a gap of not less than 0.008 inch between the formed-over end of the front contact clip and the bottom of the contact arm when the rear contact is closed.

## 2.66 Spacing Mechanism (continued)

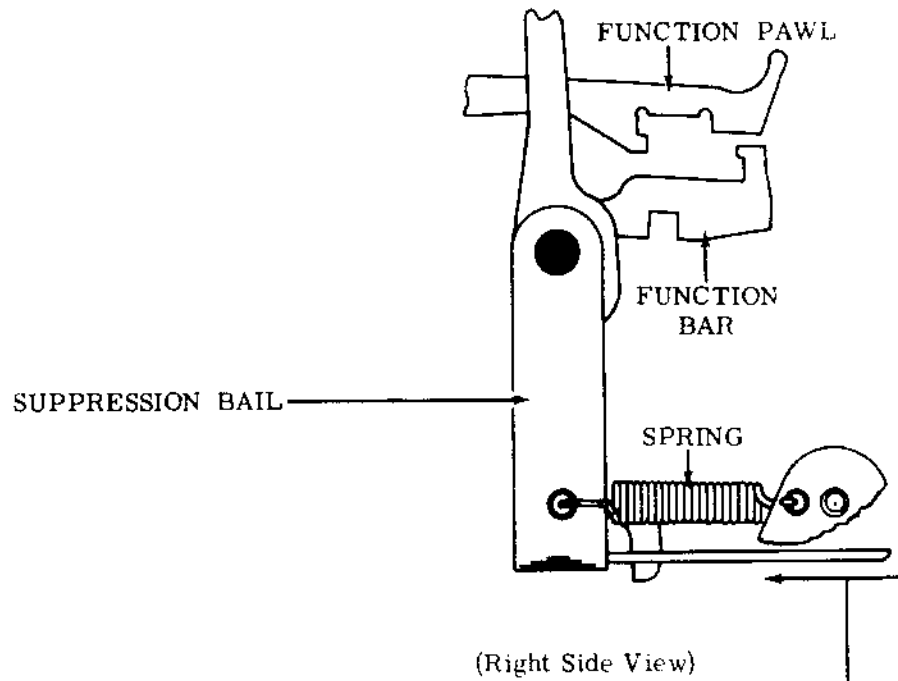
SPACING SUPPRESSION BAIL SPRING**Requirement**

Spacing suppression bail in rear position. Scale applied near center of horizontal portion of bail.

Min 1/2 oz --- Max 1-1/2 oz  
to start bail moving.

2.87 Line Feed and Platen Mechanism (continued)

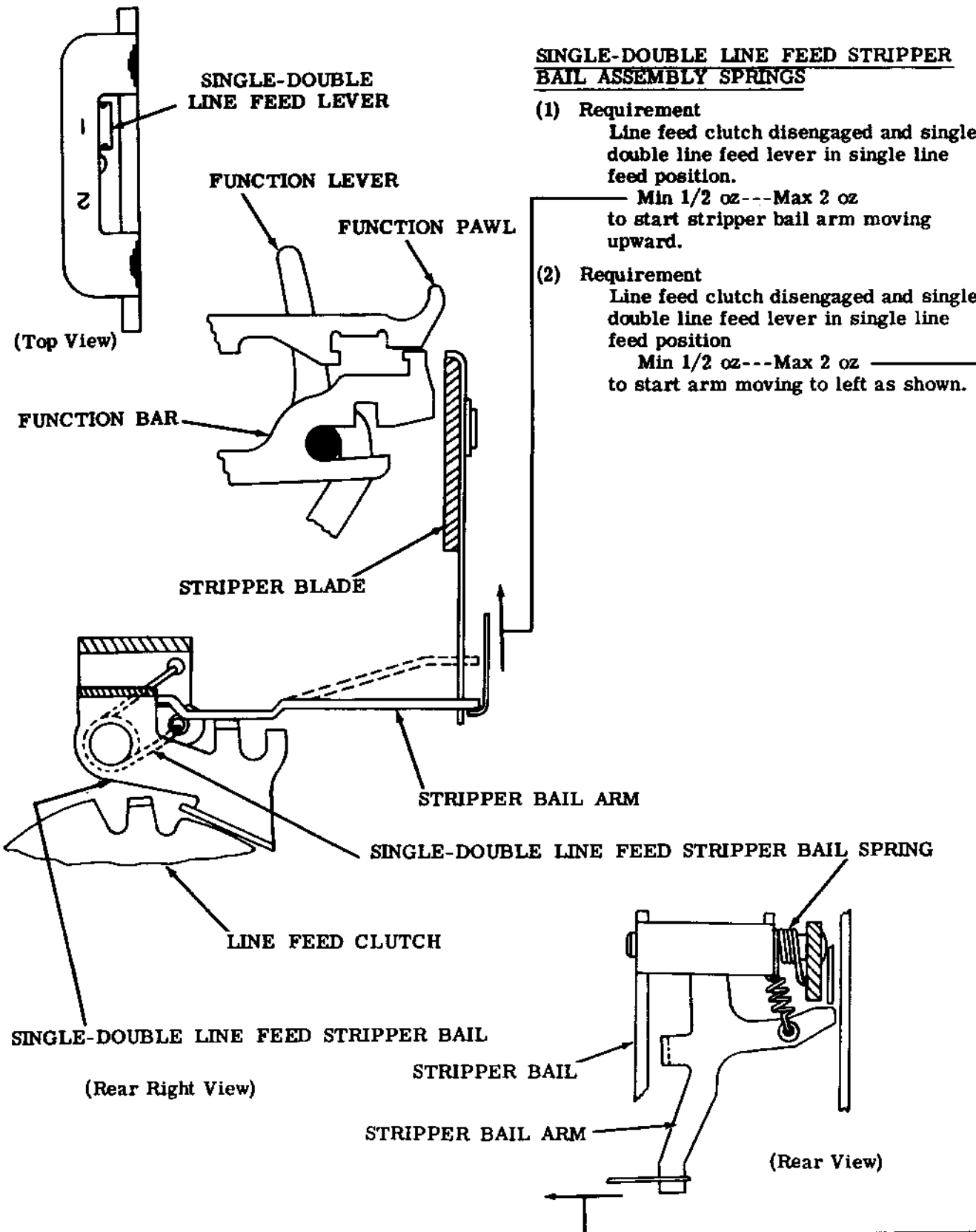

2.68 Line Feed and Platen Mechanism (continued)

RIGHT MARGIN WITH AUTOMATIC CARRIAGE RETURN-LINE FEED RING

Requirement (On Units So Equipped)

Typebox clutch disengaged. Carriage positioned two spaces before character on which automatic carriage return-line feed is to occur. Front feed pawl farthest advanced. Clearance between extension on ring and automatic carriage return-line feed bellcrank

Min 0.040 inch---Max 0.055 inch

To Adjust

Position ring with four indicated mounting screws loosened.

Note: Range of line adjustment is from 0 to 85 characters.

AUTOMATIC CARRIAGE RETURN-LINE FEED RING

FEED PAWL

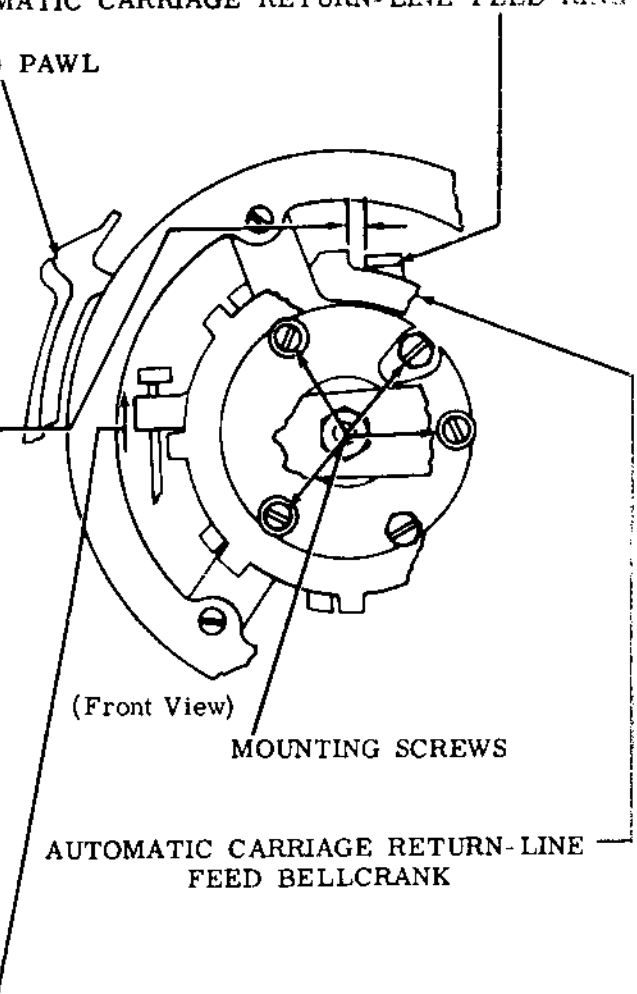

(Front View)

MOUNTING SCREWS

AUTOMATIC CARRIAGE RETURN-LINE FEED BELLCRANK

SPACING CUT-OUT TRANSFER BAIL SPRING (See 2.56)

2.69 Positioning Mechanism (continued)

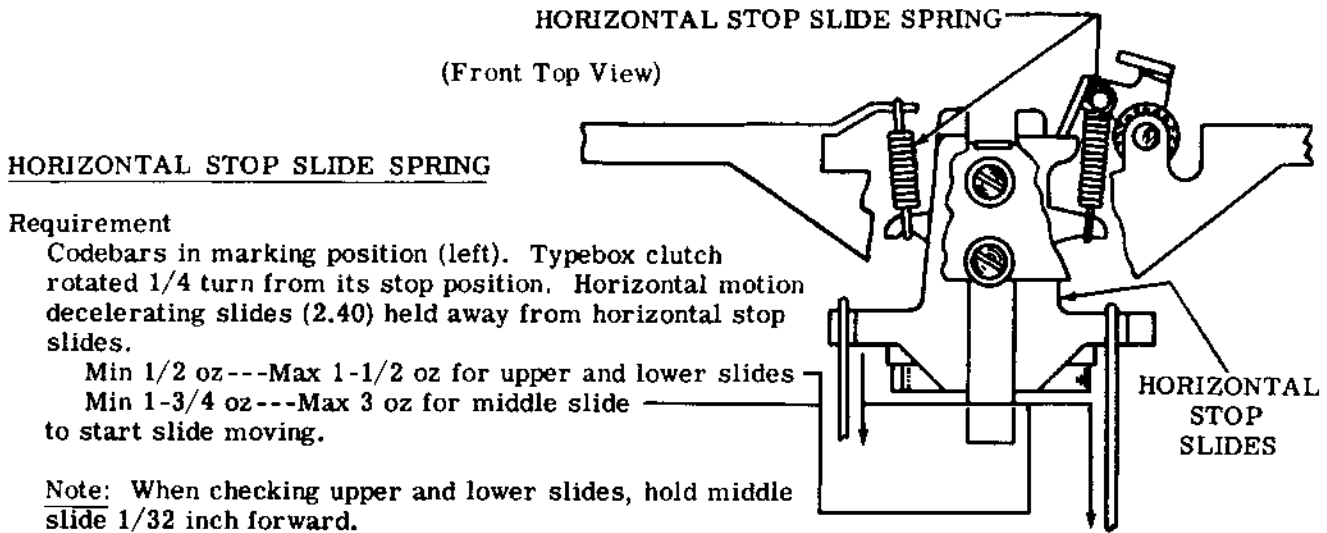

2.70 Line Feed and Platen Mechanism (continued)

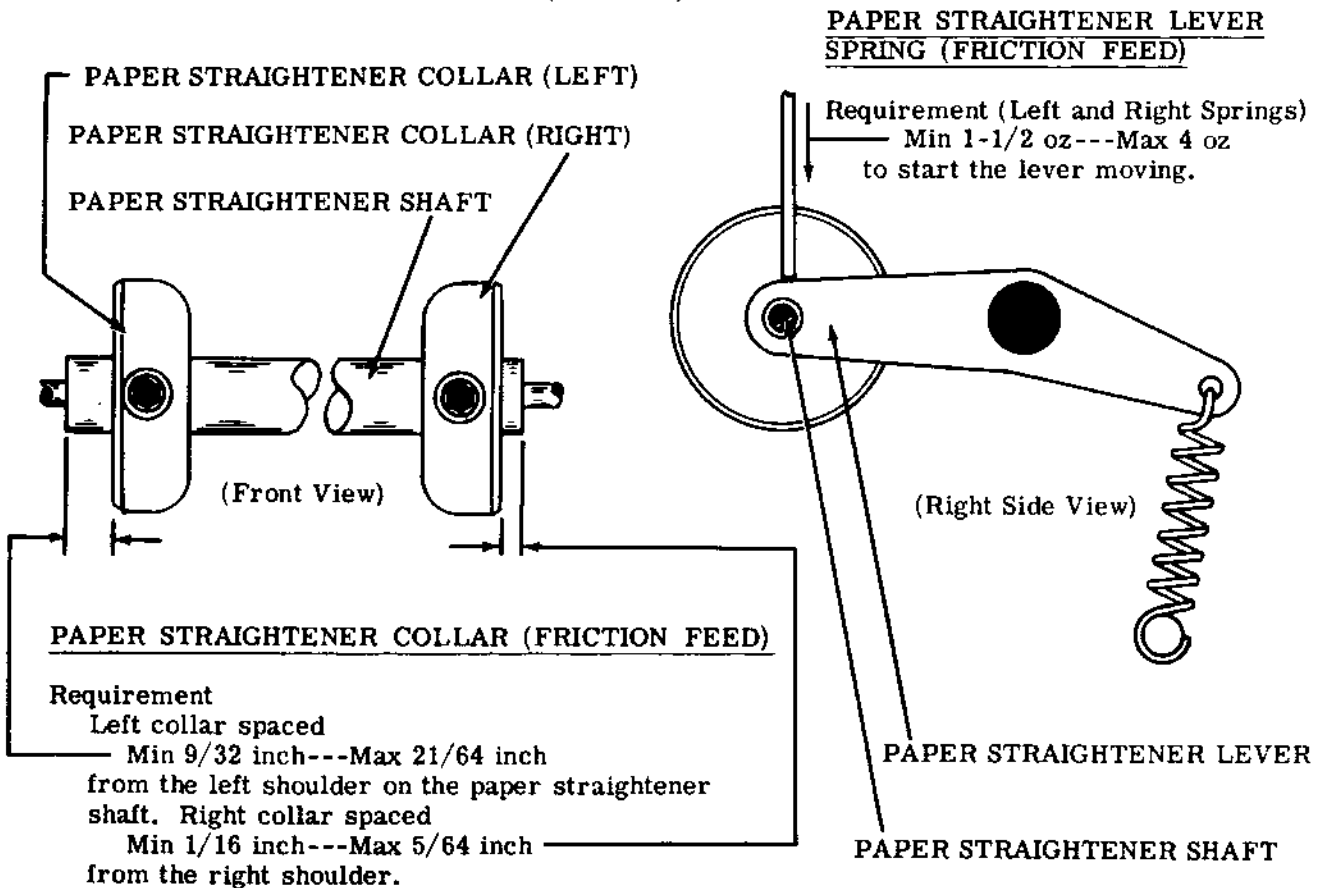

To Adjust  
Position collars on shaft with setscrews loosened.

Note: For sprocket feed mechanism, see 2.76.

2.71 Line Feed and Platen Mechanism (continued)

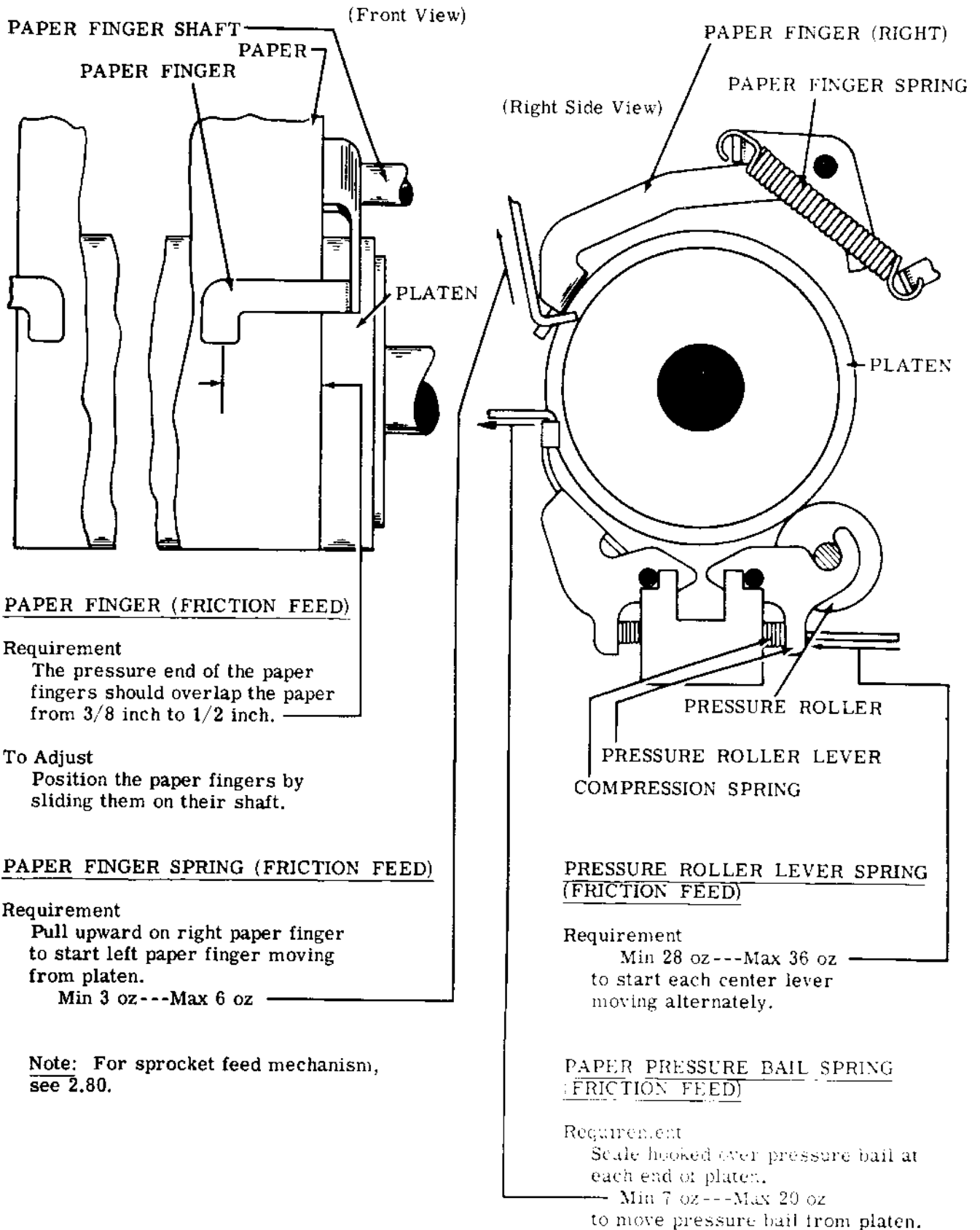



2.72 Codebar Mechanism (continued)

CODEBAR DETENT

**Requirement**

Front plate removed. All clutches disengaged. Suppression and shift codebars should detent equally (gauged by eye).

**To Adjust**

Equalize the detenting of the codebars by adding or removing shims between the casting and the codebar bracket.

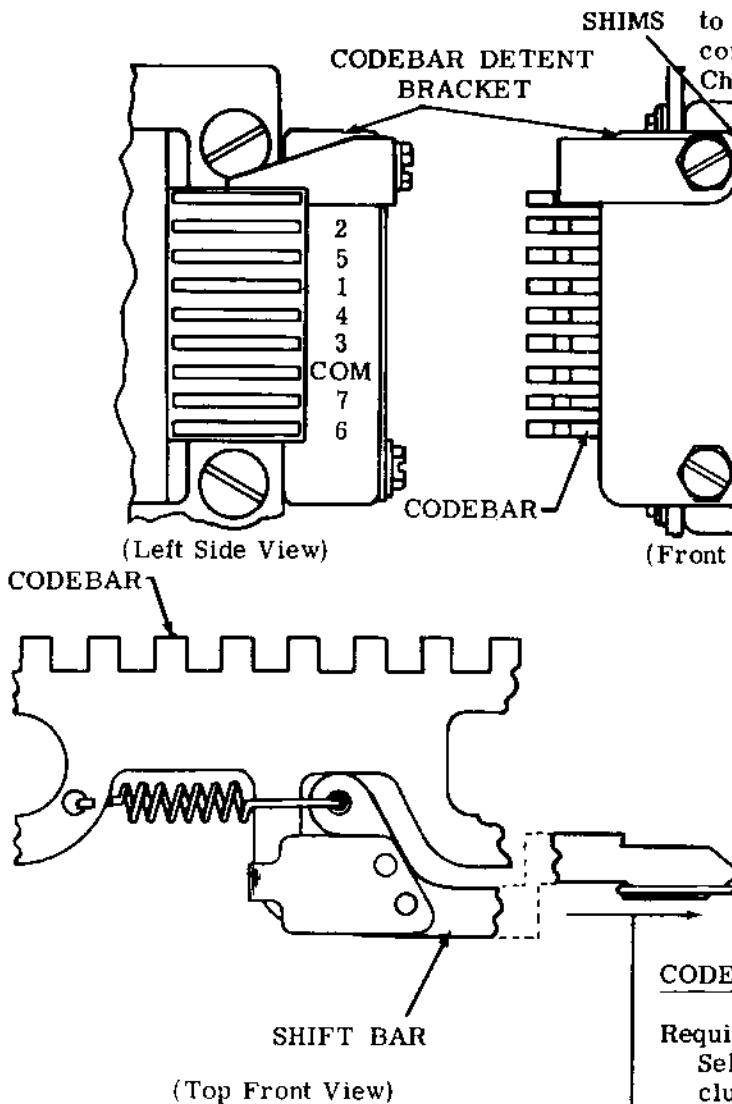

CODEBAR DETENT SPRING

**Note:** Unless there is reason to believe that these springs are causing operating failure, do not check this requirement.

**Requirement**

Codebar detent bracket carefully removed and codebars removed from detent bracket. Scale applied to detent ball and pulled in direction of ball travel

Min 1-1/2 oz---Max 3-1/2 oz  
 (no. 6 codebar for non-Bell, no. 6 and no. 7 codebars for Bell  
 Min 4 oz---Max 6 oz)

to start ball moving against compression of spring. Check each ball.

**Note:** When removing the detent assembly from the codebar bracket, be careful to maintain the correct number of shims at the upper and lower mounting screws.

CODEBAR YIELD SPRING

**Requirement**

Selector clutch, codebar clutch, and typebox clutch disengaged. No. 1 codebar in spacing position

Min 14 oz---Max 23 oz  
 to start codebar shift bar pivot moving away from codebar. Check no. 2 and common codebar shift bar in the same manner.

## 2.73 Spacing Mechanism (continued)

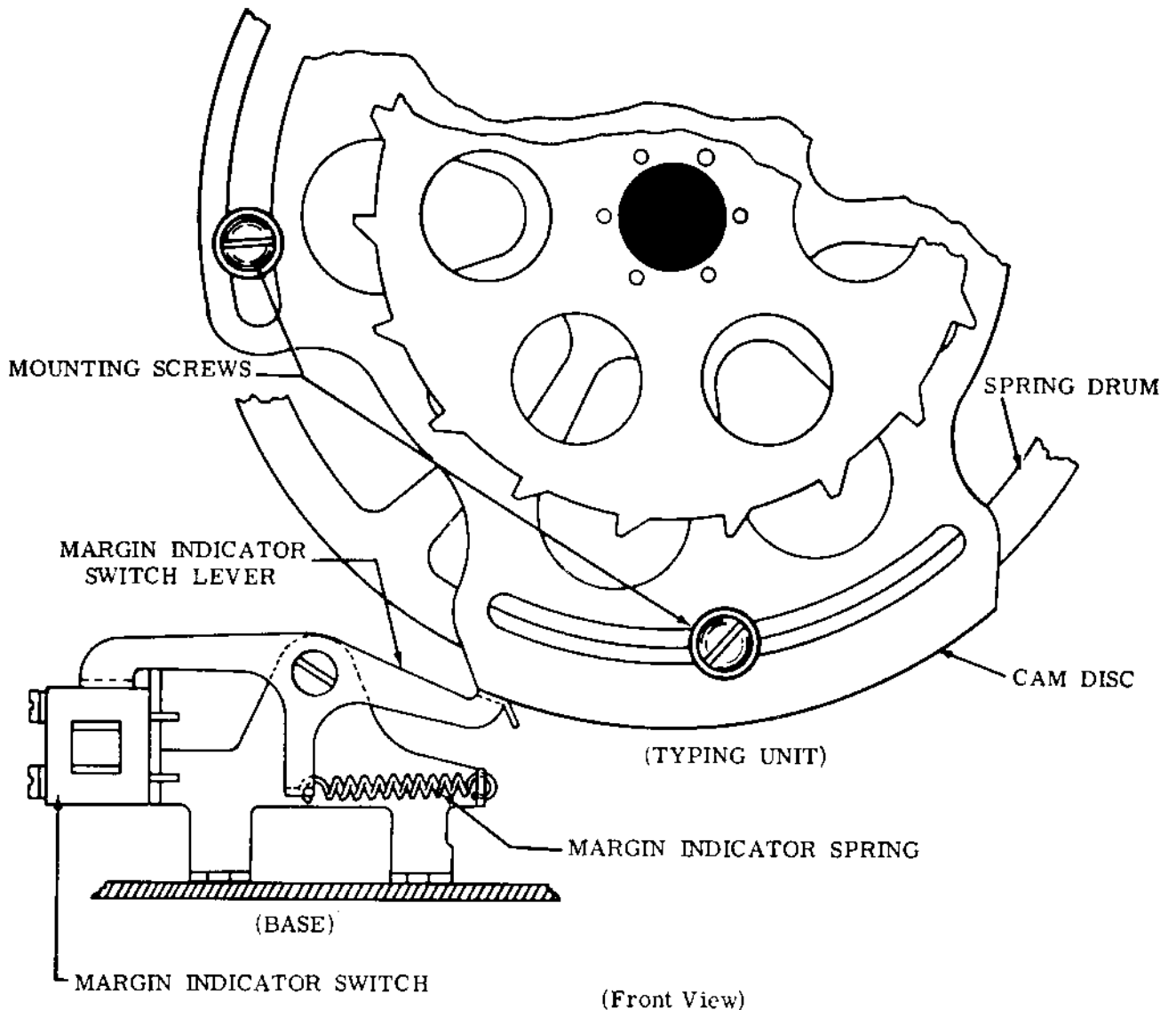
MARGIN INDICATOR LAMP**Requirement**

Operating under power, the lamp should light on the desired character.

**To Adjust**

Set the typebox carriage to print the desired character and position the cam disc counterclockwise on the spring drum with its three mounting screws loosened so that the switch just opens. If a line shorter than 72 characters is required, it may be necessary to remove the cam disc screws and insert them in adjacent slots in the disc, if the range of rotation in one slot is not enough. Range is from the 5th through the 85th character.

(Min 65 characters---Max 69 characters  
in Bell System switched network service)

2.74 Printing Mechanism (continued)

(B) PRINT SUPPRESSION BLOCKING LEVERS

To Check

Manually move blocking bail blade opposite blocking lever.

Requirement

No. 6 codebar marking. No. 7 and suppression codebars spacing. Clearance between blocking levers and blocking bail blade should be equal within 0.020 inch.

To Adjust

Position eccentric post, keeping high part of eccentric toward front of unit.

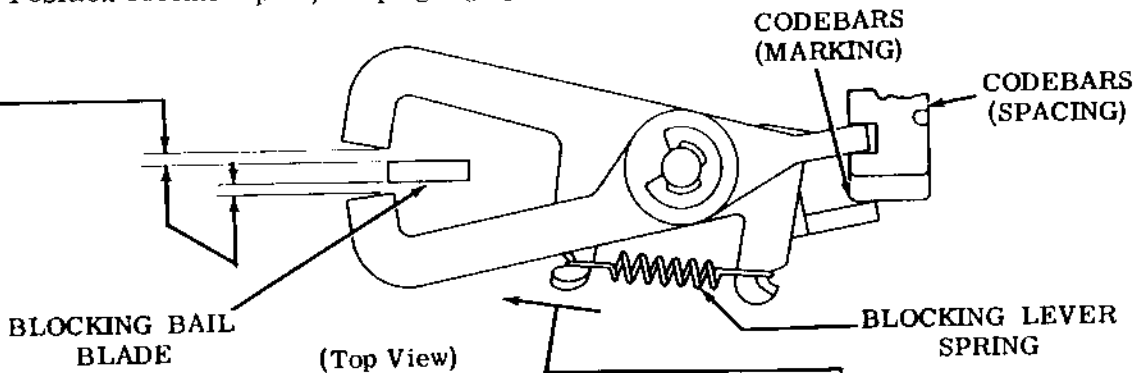

(C) PRINT SUPPRESSION BLOCKING LEVERS SPRING

Requirement

Codebars to right (spacing). Typebox clutch in stop position  
Min 2-3/4 oz --- Max 4 oz  
to start lever moving.

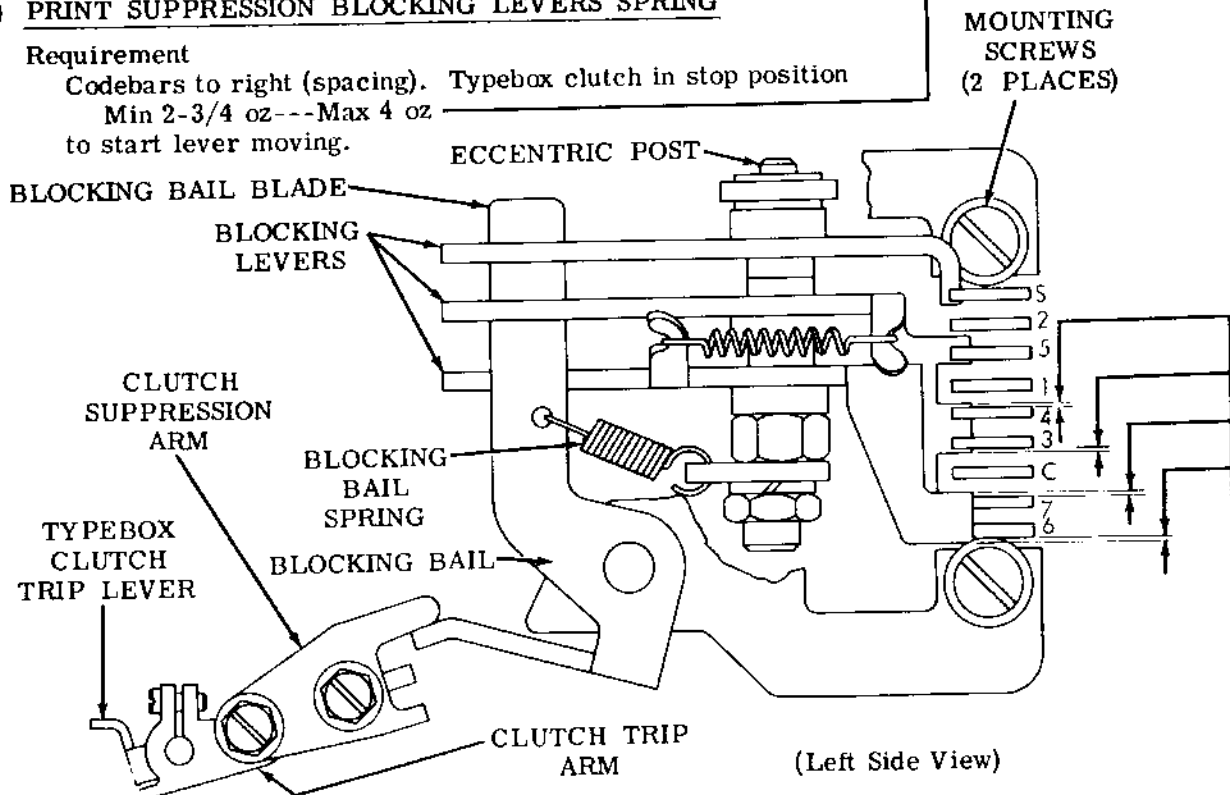

(A) PRINT SUPPRESSION MECHANISM

Requirement

Blocking lever extensions fully engaged by associated codebars.

To Adjust

Position print suppression assembly, with mounting screws friction tight, so lower lever extension is equally engaged by no. 6 and no. 7 codebars as gauged by eye.

2.75 Printing Mechanism (continued)

TYPEBOX CLUTCH SUPPRESSION ARM

Requirement

Blocking bail blocked. Rotate main shaft until function clutch shoe lever is opposite function clutch trip lever.

— Min 0.003 inch clearance between typebox clutch trip arm extension and clutch trip lever.

— Min 0.006 inch clearance between function clutch shoe lever and function clutch trip lever.

To Adjust

Position suppression arm with mounting screws friction tight.

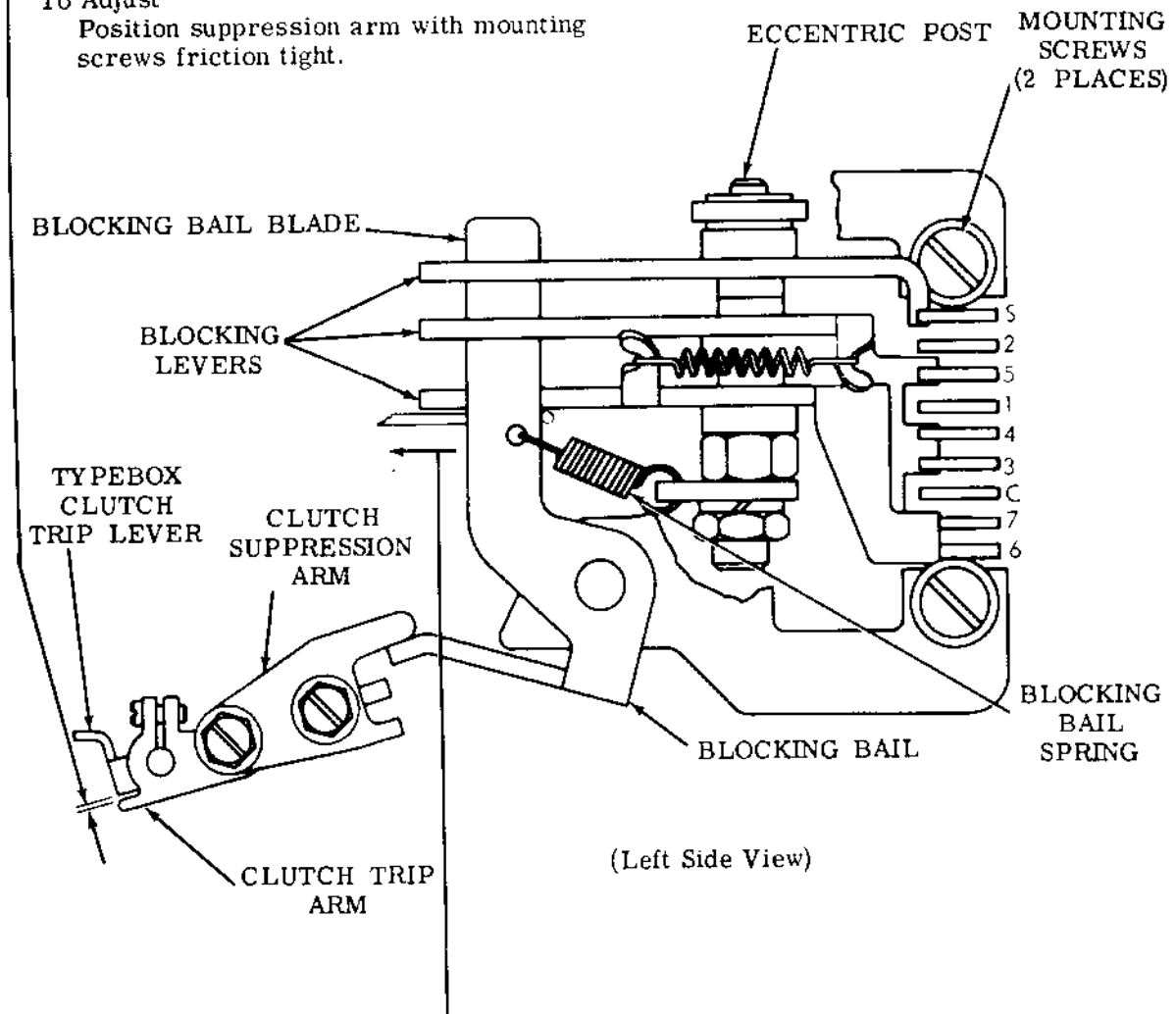

PRINT SUPPRESSION BLOCKING BAIL SPRING

Requirement

All codebars right (spacing). Typebox clutch in stop position  
 — Min 1/2 oz --- Max 1-1/2 oz to start bail moving.

2.76 Line Feed and Platen Mechanism (continued)

(A) PAPER FINGER SHAFT SPRING (SPROCKET FEED)

Requirement

Hold latch away from shaft extension  
Min 6 oz---Max 10 oz  
to move paper finger against the platen.

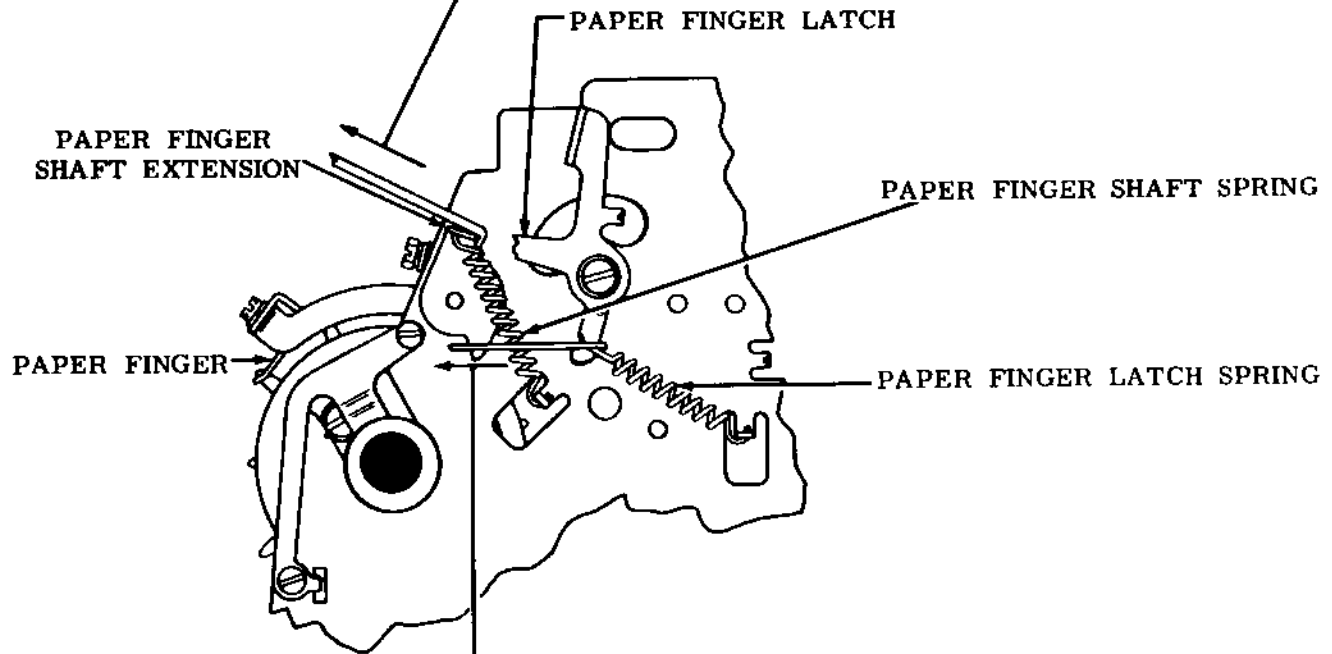

(Right Side View)

(B) PAPER FINGER LATCH SPRING (SPROCKET FEED)

Requirement

Hold paper finger against platen.  
Min 8 oz---Max 12 oz  
to start latch moving.

PLATEN DETENT BAIL SPRING

Use 2.61.

2.77 Line Feed and Platen Mechanism (continued)

(A) LEFT MARGIN (SPROCKET FEED)

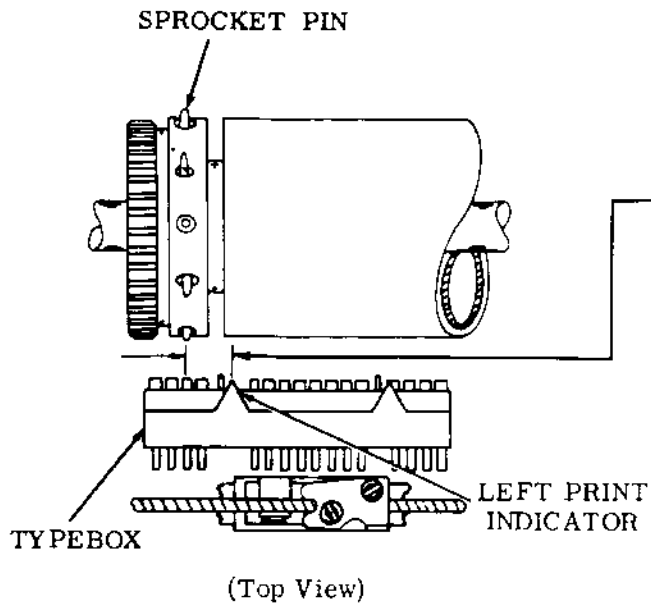

(1) Requirement

Typebox clutch disengaged. Spacing drum fully returned. Clearance between centerline of sprocket pins in left hub and print indicator located in front of printing hammer stop bracket.  
Min 5/16 inch---Max 7/16 inch

(2) Requirement

Spacing clutch disengaged. Front spacing feed pawl farthest advanced. Spacing drum fully returned. Play in spacing shaft gear (2.29) taken up clockwise. Clearance between pawl and shoulder of ratchet wheel tooth immediately ahead  
Min some---Max 0.008 inch

(3) Requirement

Rear pawl, when farthest advanced, should rest at bottom of indentation between ratchet wheel teeth.

To Adjust

Position carriage return ring with mounting screws loosened.

(B) PRINTING CARRIAGE POSITION (2.51)

(C) PRINTING HAMMER STOP BRACKET (2.54)

(D) RIGHT MARGIN (2.56)

(E) TYPEBOX ALIGNMENT (2.57)

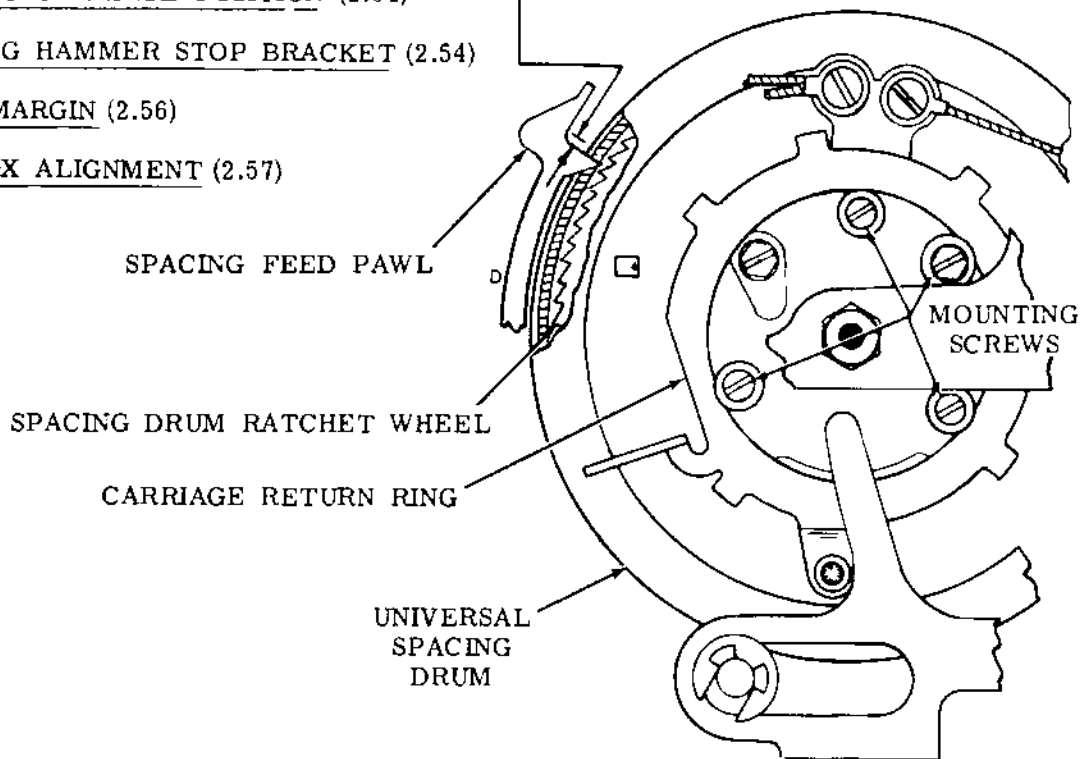

Note: Following this adjustment, all screws should be tightened.

2.78 Line Feed and Platen Mechanism (continued)

(A) LINE FEED SPUR GEAR DETENT ECCENTRIC Use 2.61.

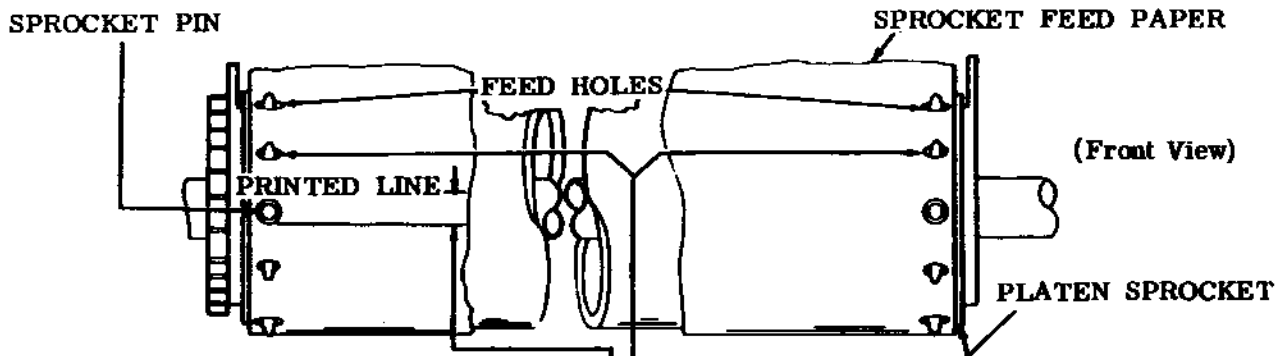

(B) PRINTED LINE (SPROCKET FEED)

Requirement

The bottom of the printed line should be  $1/32$  inch  $\pm$   $1/64$  inch (plus a multiple of  $1/8$  inch if required) above a horizontal line drawn even with the bottom edge of any sprocket hole.

To Adjust

Loosen screws and position left sprocket.

**Note:** This adjustment is dependent on the type of form, and the location of the first printed line. The tolerances are field limits therefore the adjustment is not made in the factory.

(D) SPROCKET PIN SEPARATION (SPROCKET FEED)

(1) Requirement

With single sheet of sprocket feed paper placed on the platen the sprocket pins should be centrally located in the feed holes of the paper.

(2) Requirement

Printed line should be parallel to a line drawn perpendicular to edge of paper within plus or minus  $1/32$  inch.

To Adjust

Position right sprocket with clamp screw loosened.

(C) PLATEN ENDPLAY (SPROCKET FEED)

Requirement

Line feed pawls disengaged. Platen shaft should have some endplay

Max 0.010 inch

To Adjust

Position platen spur gear with clamp screw loosened.

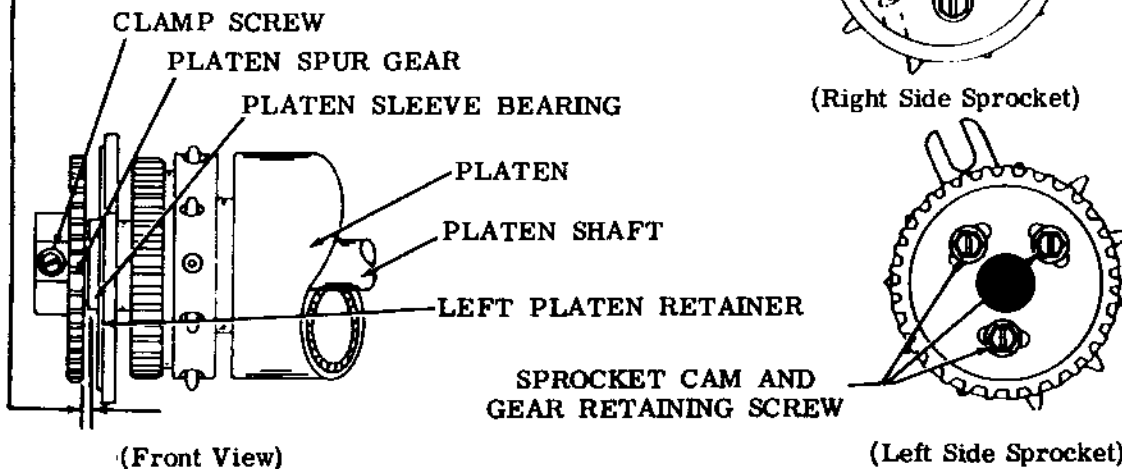

2.79 Line Feed and Platen Mechanism (continued)

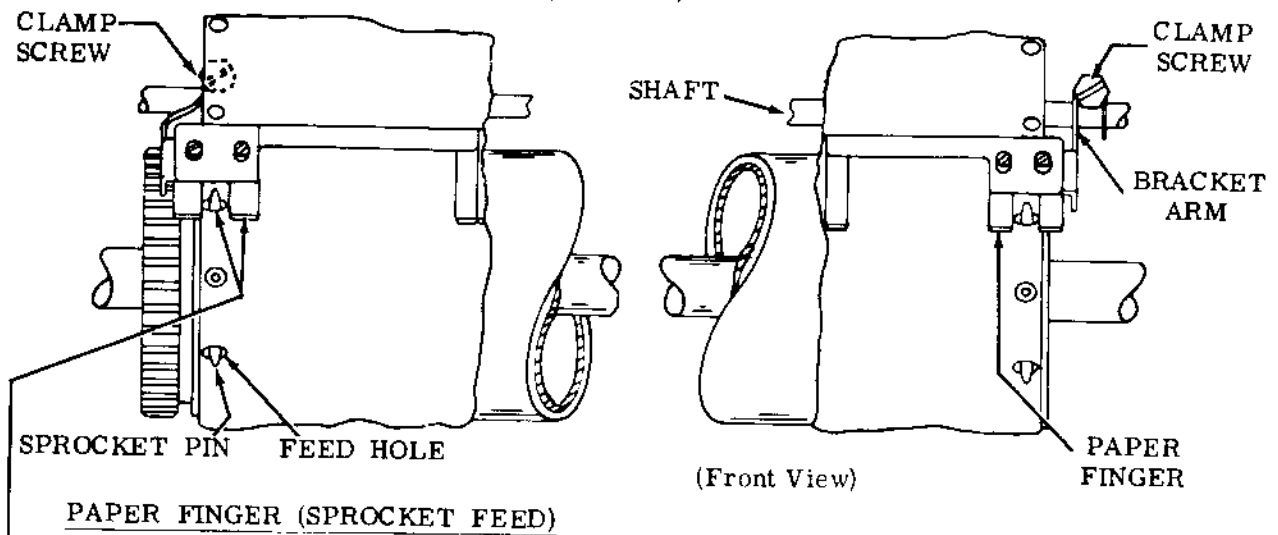

(1) Requirement

Sprocket pin should be centrally located in the paper finger slot.

(2) Requirement

The gap between the platen and the paper finger should be

Min 0.050 inch---Max 0.150 inch  
(for stapled copies)

Min 0.020 inch---Max 0.060 inch  
(unstapled or single copy).

**Note:** It is desirable to have the clearance at the minimum which will pass the stationery freely. This minimum is dependent upon the type of paper, number of copies, stapling, etc.

To Adjust

With paper finger assembly in latched position, loosen both clamp screws, position assembly horizontally to meet Requirement (1). Rotate assembly to meet Requirement (2).

(3) Requirement (Not Illustrated)

Min 0.035 inch

between leading edge of paper finger and ribbon guide. Both right and left paper fingers must be parallel to the same printed line as gauged by eye.

To Adjust

Select rubout combination and rotate typebox clutch 1/2 revolution. Position paper fingers by means of elongated mounting holes. After tightening the screws recheck Requirements (1), (2), and (3).

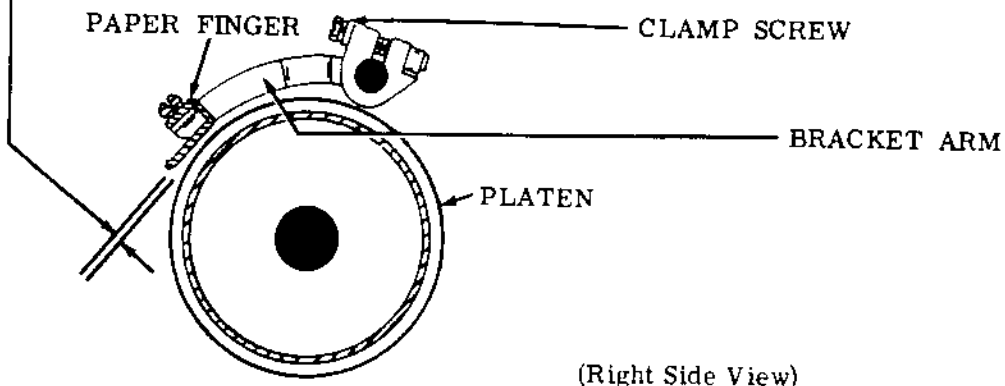

(Right Side View)



2.80 Line Feed and Platen Mechanism (continued)

**(B) SPROCKET PIN SPRING (SPROCKET FEED)**

Requirement (Early Design)

Pins to be tested aligned with slots in guide bracket.

Min 6 oz---Max 8 oz  
to start depressing the pin.

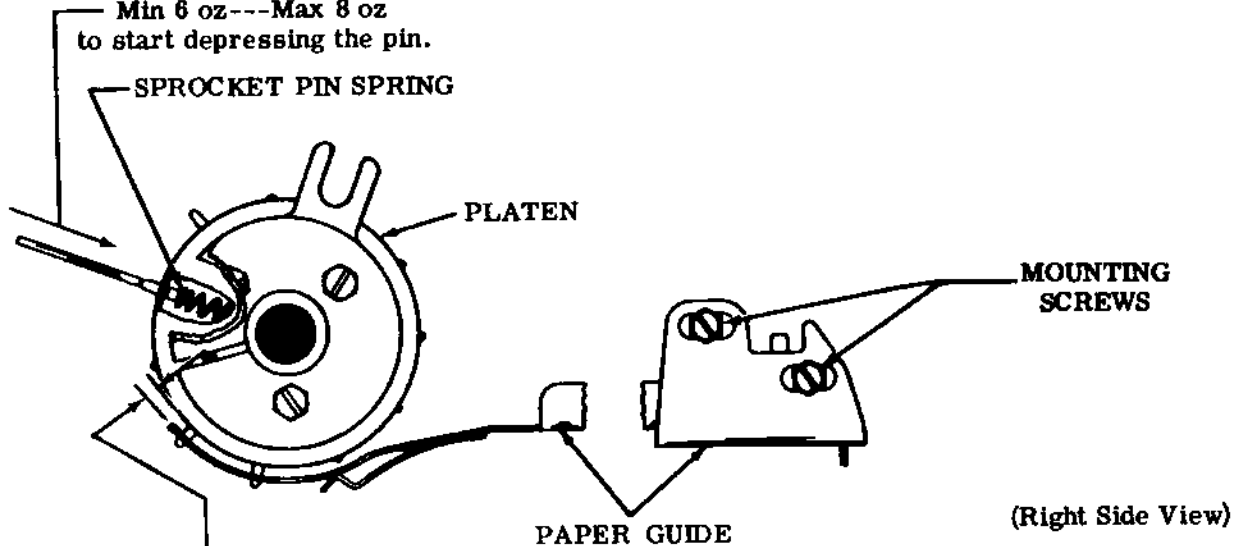

**(A) PAPER GUIDE (SPROCKET FEED)**

Requirement

The clearance between the platen and the front edge of the paper guide should be

Min 0.050 inch---Max 0.150 inch  
(stapled copies)

Min 0.020 inch---Max 0.060 inch  
(unstapled or single copy).

To Adjust

Position the guide with its rear mounting screws loosened.

**(C) RIBBON REVERSE SPUR GEAR**

Use 2.58.

**(D) RIBBON REVERSE DETENT**

Use 2.58.

**(E) LINE FEED BAR BELLCRANK SPRING (SPROCKET FEED)**

Use 2.61 except

Min 28 oz---Max 38 oz  
to start bar moving.

Note: It is desirable to have the clearance at the minimum which will pass the stationery freely. This minimum is dependent upon the type of paper, number of copies, stapling, etc.

2.81 Function Mechanism (continued)

STRIPPER SLIDE BAIL ARM

(1) Requirement

Clearance between top edge of stripper slide bail and lower surface of the closest line feed function pawl should be

Min 0.030 inch---Max 0.045 inch

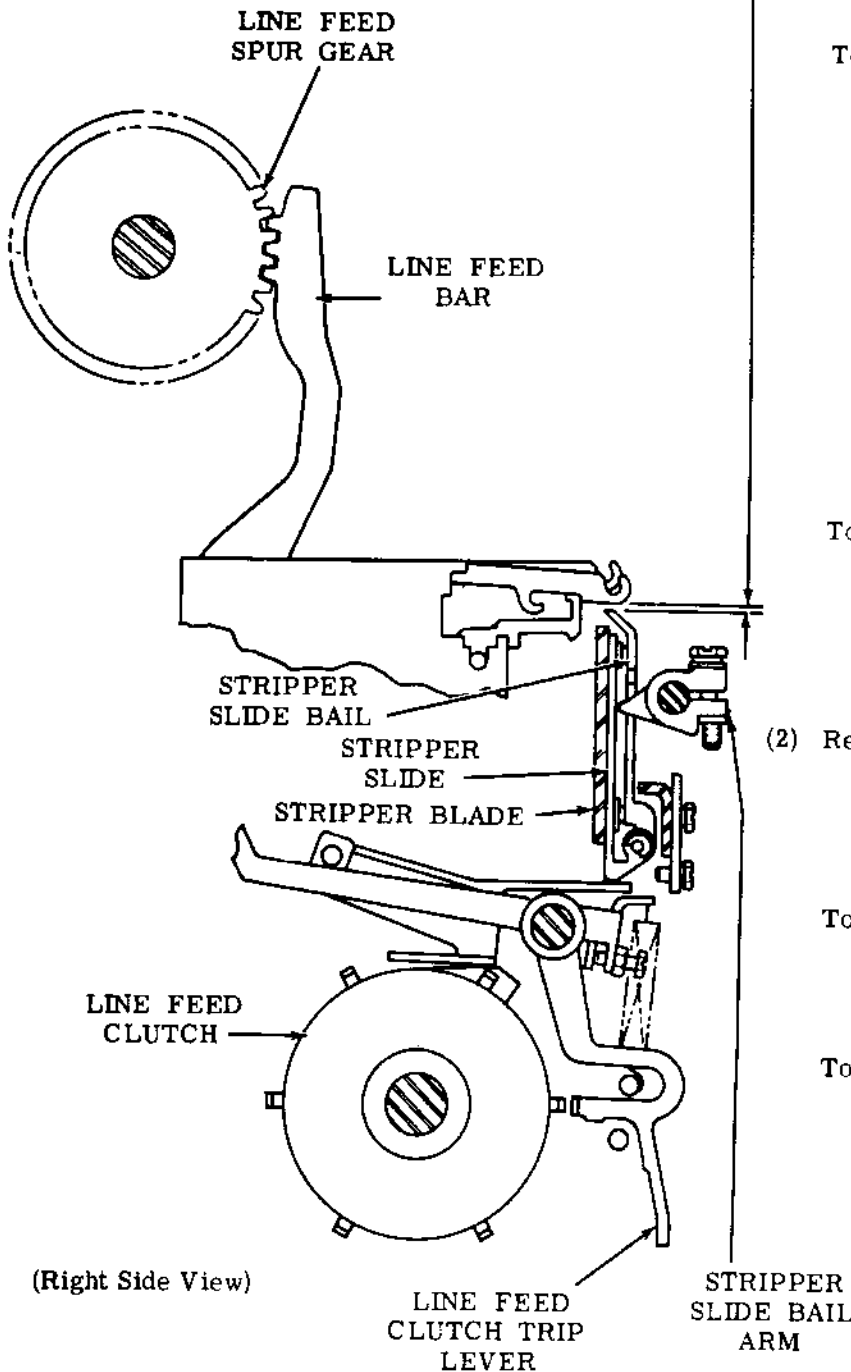

To Check

Single-double line feed lever in double line feed position and all clutches in latched stop position. Select line feed function. Rotate main shaft until codebar clutch stop lever just touches codebar clutch shoe lever. Take up play of stripper bail cam shaft drive arm to make clearance a maximum between the stripper bail and line feed function pawl. Take up play of stripper slide bail and function pawl in downward direction.

To Adjust

Position stripper slide bail arm with its clamping screw loosened. Position arm laterally to clear stripper slide when screw is tightened.

(2) Requirement

The line feed trip lever should reset at a point over, or just past, the second stop-lug by not more than 1/3 the distance between lugs.

To Check

Single-double line feed lever in double position. Select line feed function and rotate main shaft.

To Adjust

Refine LINE FEED CLUTCH TRIP LEVER ADJUSTING SCREW (2.25), if necessary. Recheck Requirement (1) of this adjustment.

2.82 Function Mechanism (continued)

STRIPPER SLIDE SPRING

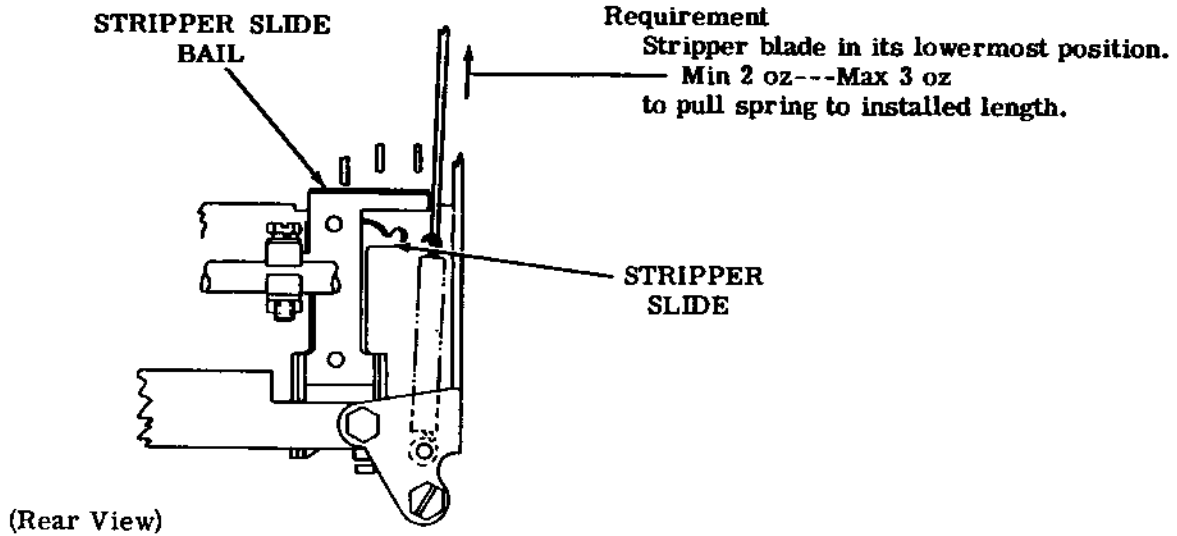

STRIPPER SLIDE BAIL TORSION SPRING

Requirement  
Single-double feed lever in single position.  
Select line feed function and rotate main  
shaft until stripper slide bail just strips  
line feed function pawl.  
Min 1 oz---Max 1-1/2 oz  
to just start bail moving.

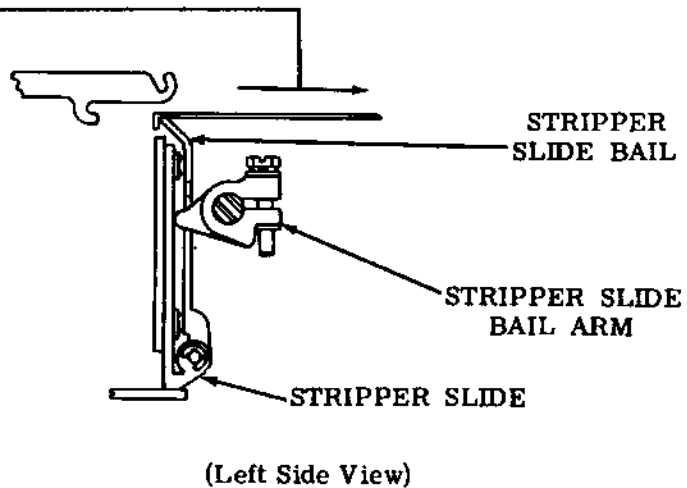

3. VARIABLE FEATURES

3.01 Vertical Tabulator Mechanism (For Bell System Switched Network Service)

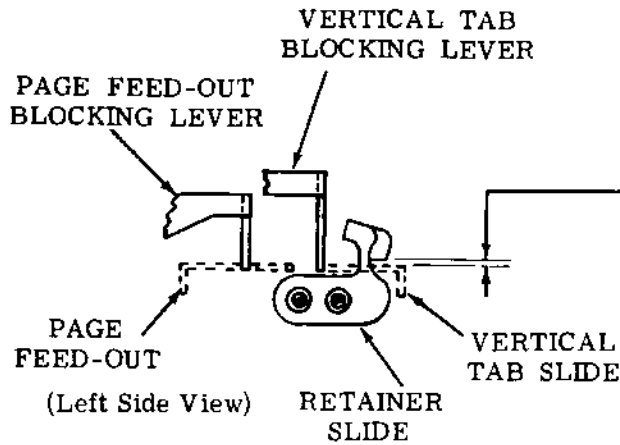

(A) VERTICAL TABULATOR SLIDE RETAINER

Requirement

Clearance between vertical tab slide and retaining edge of retainer  
 Min some---Max 0.012 inch

To Adjust

Move retainer to extreme forward position and locate up or down to meet requirement.

(B) MOUNTING BRACKET

(1) Requirement

Select form-out code combination and rotate main shaft until form-out slide is in forwardmost position. Clearance between form-out (inside) blocking lever and form-out slide.

Min some---Max 0.020 inch when play in blocking lever is taken up to make clearance minimum.

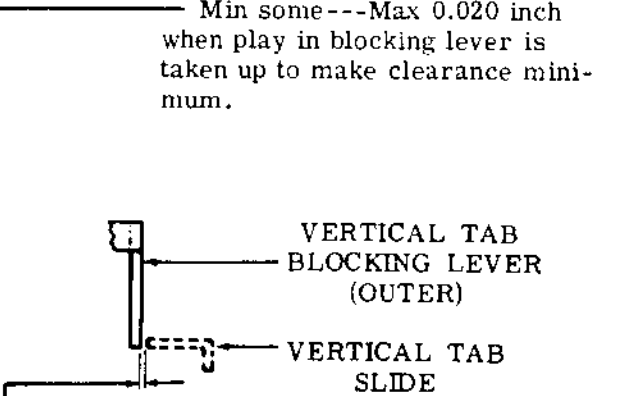
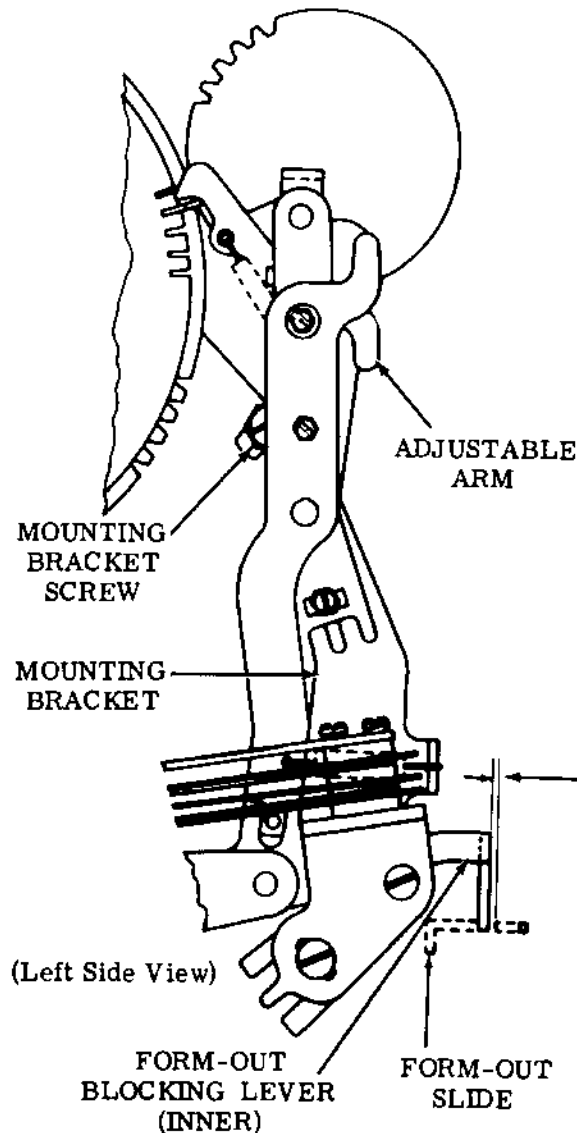

(2) Requirement

Select vertical tab code combination and rotate main shaft until vertical tab slide is in forwardmost position. Clearance between vertical tab slide and vertical tab blocking (outer) lever

Min 0.002 inch when play in blocking lever is taken up to make clearance minimum.

To Adjust

With mounting bracket screw friction tight, position lower portion of mounting bracket to meet Requirements (1) and (2).

3.02 Vertical Tabulator Mechanism (continued)  
(For Bell System Switched Network Service)

(B) INDEXING DISC

Requirement

Line feed clutch disengaged. Form-out stop plate adjacent to form-out follower. Clearance between stop plate and follower

— Min 0.015 inch---Max 0.040 inch with slack taken up in idler and form start gears to make gap minimum.

To Adjust

Pull gear out of engagement with idler. Turn handwheel clockwise until a stop plate just operates follower and then engage first tooth on idler. Position disc with three mounting screws.

(C) POINTER ADJUSTMENT

Requirement

Line feed clutch disengaged. Form-out stop plate adjacent to follower. Pointer on printer side frame should line up with notch in index disc.

To Adjust

Pointer mounting screw, on printer side frame, friction tight. Position pointer so it lines up with notch on index disc, and clears any stop plate by approximately 1/16 inch.

(A) FORM START GEAR PLAY

Requirement

Barely perceptible backlash between idler gear and form start gear.

To Adjust

Position gear pivot post on bracket by nut in center of handwheel. Check in at least three position, 120 degrees apart.

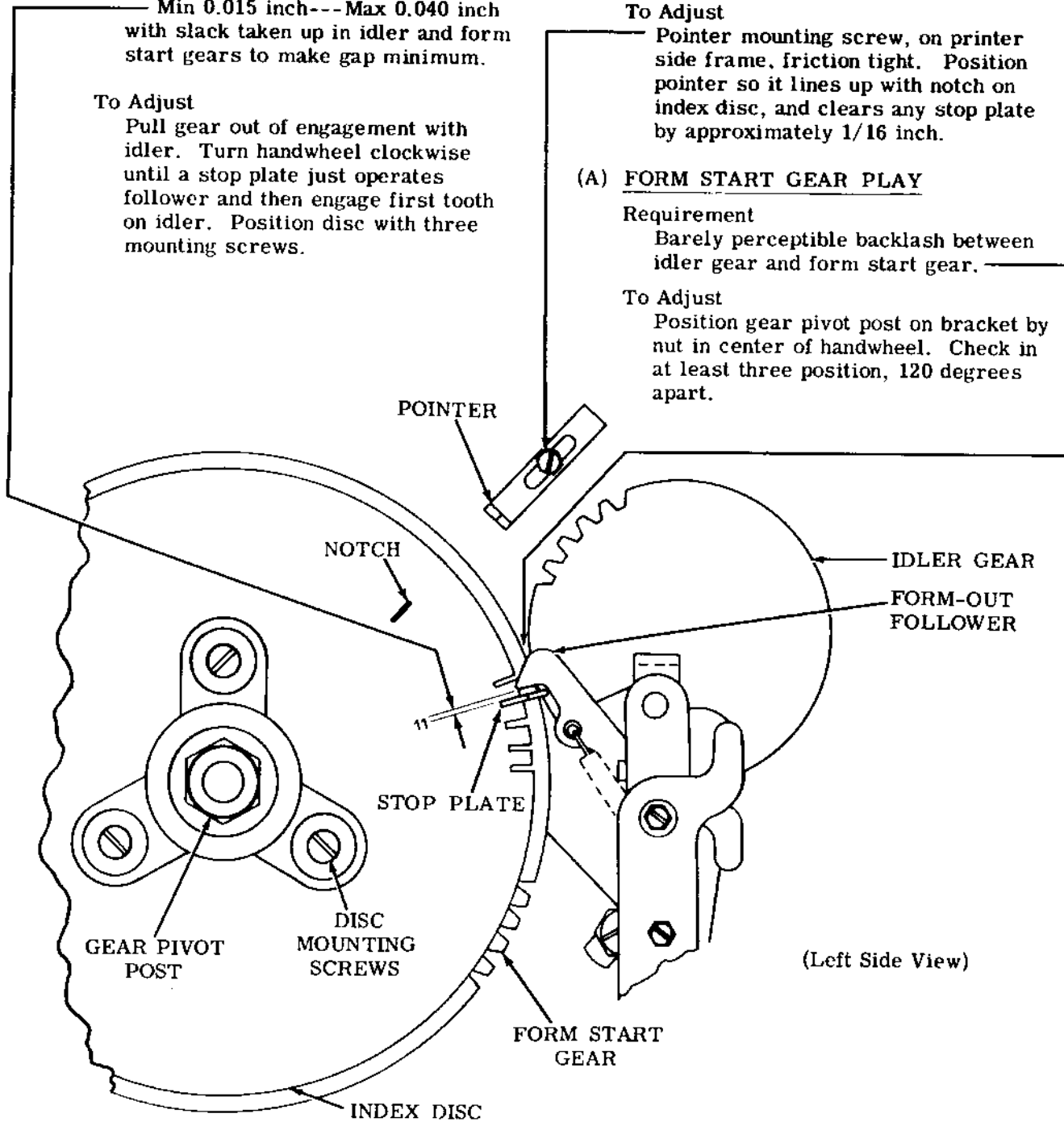

(Left Side View)

3.03 Vertical Tabulator Mechanism (continued)  
 (For Bell System Switched Network Service) (Transmitter Control Switch Adjustments)

(D) NORMALLY OPEN CONTACT GAP

Requirement  
 Blocking levers unoperated. Gap between normally open contacts  
 Min 0.008 inch---Max 0.012 inch

To Adjust  
 Bend stiffener.

(A) TRANSFER CONTACT SPRING

Requirement  
 Blocking levers unoperated.  
 Min 2 oz---Max 3 oz  
 to just open contacts. Bend long contact spring to meet requirement.

(H) VERTICAL TAB BLOCKING LEVER SPRING

Requirement  
 Blocking lever arms resting on top of their slides. Unhook blocking lever spring from mounting bracket.  
 Min 9 oz---Max 11 oz  
 to pull spring to operating length. Check both blocking lever springs.

(B) NORMALLY OPEN CONTACT SPRING

Requirement  
 Blocking levers unoperated  
 Min 1 oz---Max 2 oz  
 to just move short contact spring away from stiffener. Bend short contact spring to meet requirement.

(Left Side View)

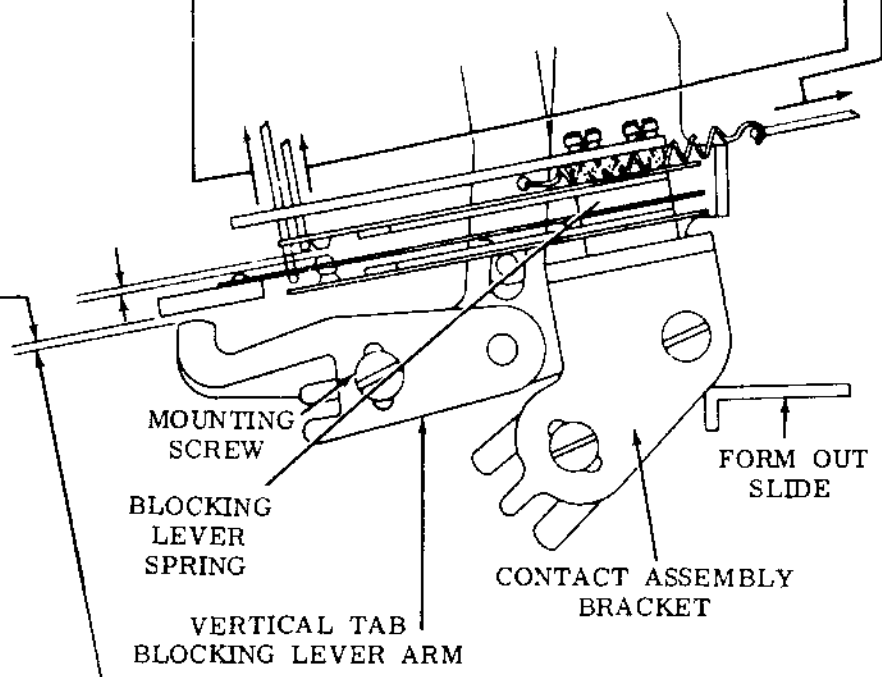

(F) VERTICAL TAB BLOCKING LEVER ARM

Requirement  
 Vertical tab blocking lever resting on top of slide, clearance between blocking lever arm and insulator pad  
 Min some

To Adjust  
 Position blocking lever arm with mounting screws friction tight.

(E) CONTACT BRACKET

Requirement  
 Form-out blocking lever resting on top of form-out slide. Clearance between blocking lever and insulator tip of swinger  
 Min some

To Adjust  
 Position contact assembly bracket with mounting screws friction tight.

3.04 Vertical Tabulator Mechanism (continued)  
 (For Bell System Switched Network Service) (Transmitter Control Switch Adjustments)

(G) NORMALLY CLOSED CONTACT GAP

(1) Requirement

Select form-out code combination. Rotate main shaft until form-out slide is in forwardmost position and form-out blocking lever drops behind slide. Clearance between normally closed contact points  
 — Min 0.008 inch

To Adjust

Refine NORMALLY OPEN CONTACT GAP and CONTACT BRACKET (3.03, (D) and (E)).

(2) Requirement

Select vertical tab code combination. Rotate main shaft until vertical tab slide is in forwardmost position and vertical tab blocking lever drops behind slide. Clearance between normally closed contact points  
 — Min 0.008 inch

To Adjust

Refine NORMALLY OPEN CONTACT GAP and VERTICAL TAB BLOCKING LEVER ARM (3.03, (D) and (F)).

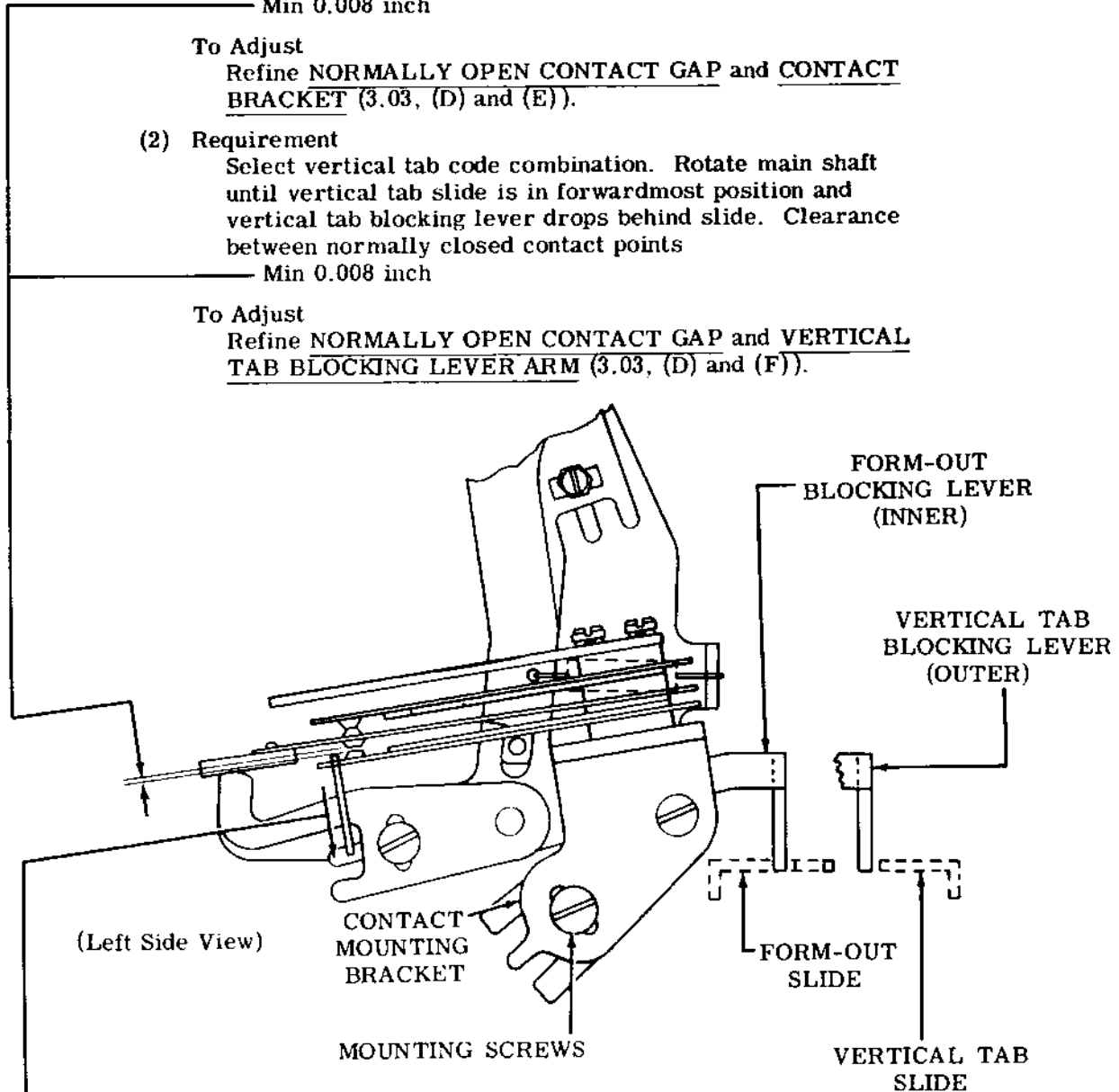

(C) NORMALLY CLOSED CONTACT SPRING

Requirement

Blocking levers operated  
 — Min 2 oz---Max 3 oz  
 to just move short contact spring away from stiffener.  
 Bend short contact spring to meet requirement.

3.05 Vertical Tabulator Mechanism (continued)  
 (For Bell System Switched Network Service) (Form-Out and Tabulator Stops)

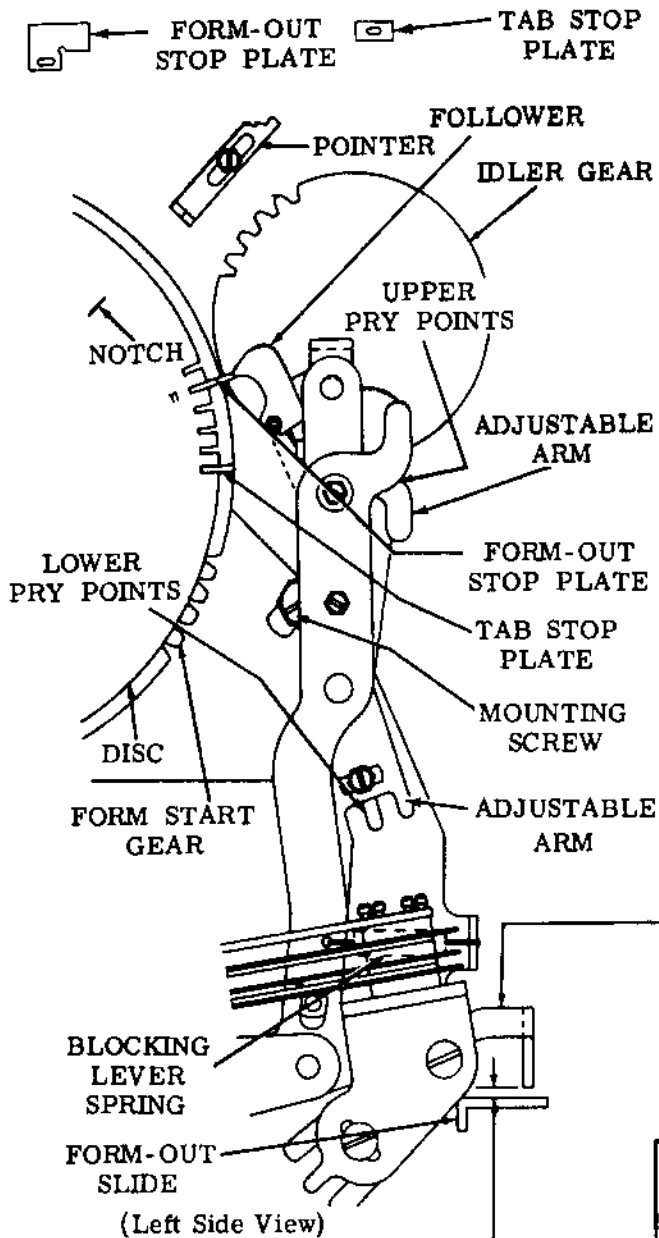

**Note 1: Form-Out Stop Adjustment** — Form-out index plates should be placed in numbered slots corresponding to length of form to be used. Form-out device may now be synchronized with form by first positioning form so that typing unit prints in first typing line of form. (When typing unit is in stop position, top of ribbon guide lines up with bottom of printing line.) With form in this position, pull form start gear out of engagement with idler and turn it until pointer on printer side is lined up with notch in index disc. (Form start gear is held in engagement with idler by spring tension, and may be disengaged by pulling the handwheel assembly out to left.)

**Note 2: Tabulation Stop Adjustment** — Tabulation stops within a form may be synchronized by first positioning form so typing unit will print on first typing line of form. (Procedure is outlined in Note 1.) Next, line feed platen to desired first printing line in form. Place tab stop plate in disc slot which lines up with vertical tab follower (inner). In same manner, place tab stop plates at succeeding desired printing lines within form. Tab stop plates may be placed on their sides in disc to nullify undesired printing positions on form.

**BLOCKING ARM (FORM-OUT)**

**Requirement**

Clearance between bottom of form-out blocking lever and top of form-out slide  
 Min 0.005 inch---Max 0.045 inch

**To Check**

Trip line feed clutch. Rotate main shaft until form-out follower is on peak of form-out stop plate.

**To Adjust**

Position adjustable arm at lower pry points with clamp screw loosened.

**BLOCKING ARM (VERTICAL TAB)**

**Requirement**

Clearance between bottom of vertical tab blocking lever and top of vertical tab slide  
 Min 0.005 inch---Max 0.045 inch

**To Check**

Trip line feed clutch. Rotate main shaft until vertical tab follower is on peak of tab stop plate.

**To Adjust**

Position adjustable arm at upper pry points with clamp screw loosened.



3.06 Vertical Tabulator Mechanism (continued)  
 (For Bell System Switched Network Service) (Off Normal Contact Adjustments)

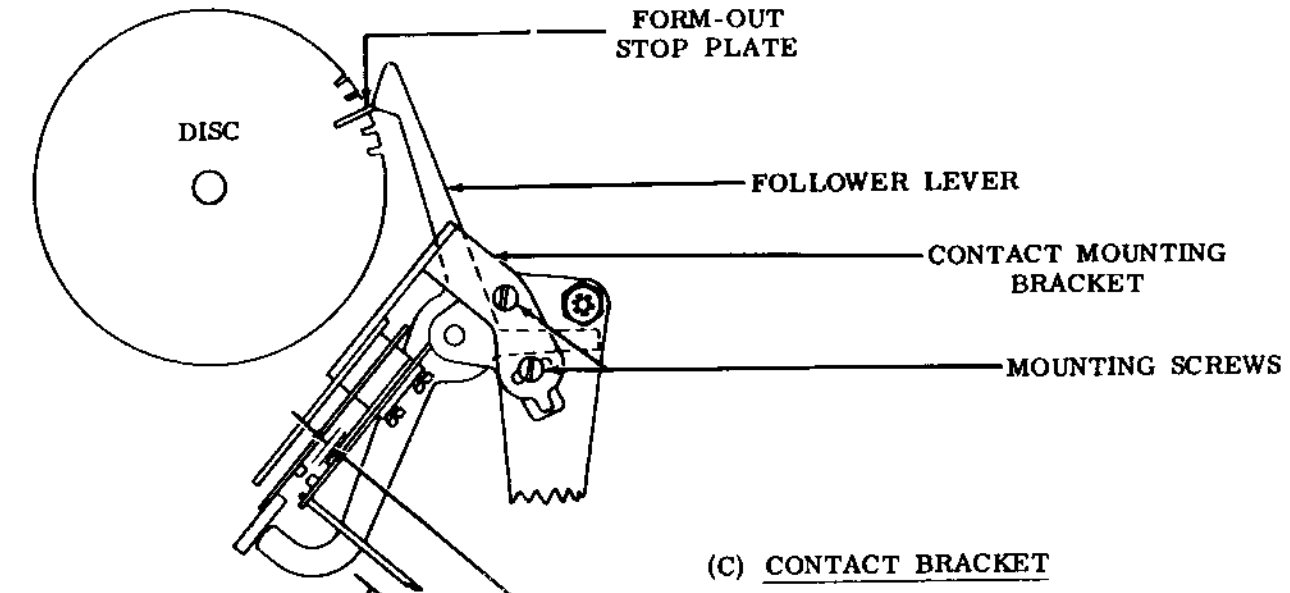

(Left Side View)

(C) CONTACT BRACKET

Requirement

Follower lever on peak of a form-out stop plate. Clearance between contact points

Min 0.010 inch---Max 0.020 inch

To Adjust

Position contact assembly bracket with mounting screws friction tight.

(A) SHORT CONTACT SPRING

Requirement

Follower lever operated.  
 Min 2 oz---Max 3 oz  
 to just move short contact spring away from stiffener. Bend short contact spring to meet requirement.

(B) LONG CONTACT SPRING

Requirement

Follower lever unoperated.  
 Min 2 oz---Max 3 oz  
 to just open contacts. Bend long contact spring to meet requirement.

(D) FOLLOWER LEVER

Requirement

Index disc rotated to bring form-out stop plate one slot away from operating position. Clearance between follower lever and insulator tip  
 Min 0.010 inch---Max 0.020 inch

To Adjust

Rotate eccentric post until requirement is met.

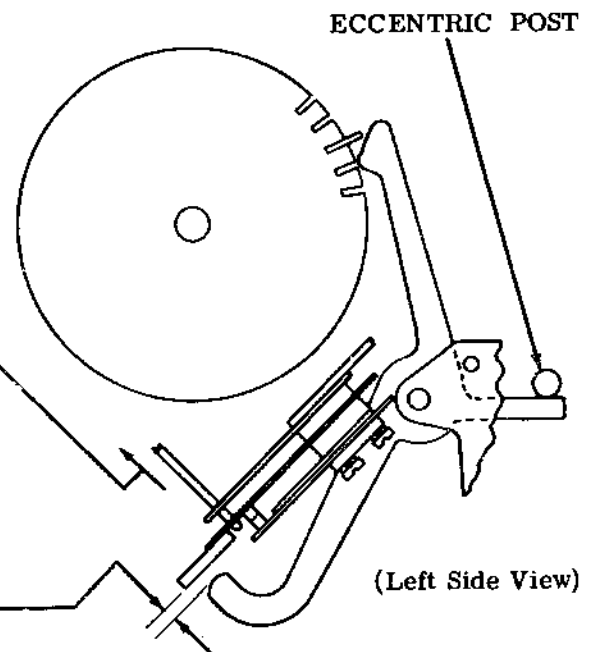

(Left Side View)

3.07 Vertical Tabulator Mechanism (continued)  
(Common to 3.01 and 3.24)

FORM-OUT PAWL SPRING

Requirement

Form-out pawl extension resting against backstop.  
Min 3 oz---Max 8 oz  
to move pawl away from backstop.

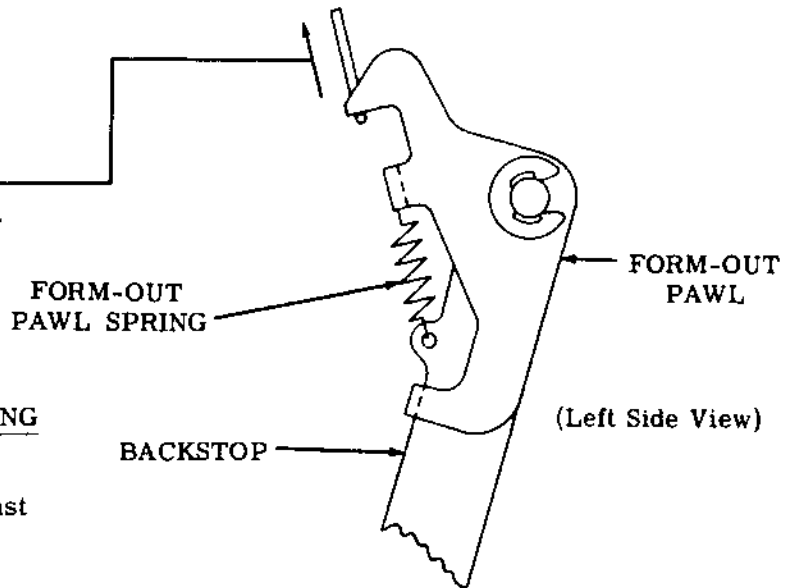

VERTICAL TABULATOR BAIL SPRING

Requirement

Extension of tab bail resting against backstop.  
Min 3 oz---Max 8 oz  
to move bail away from backstop.

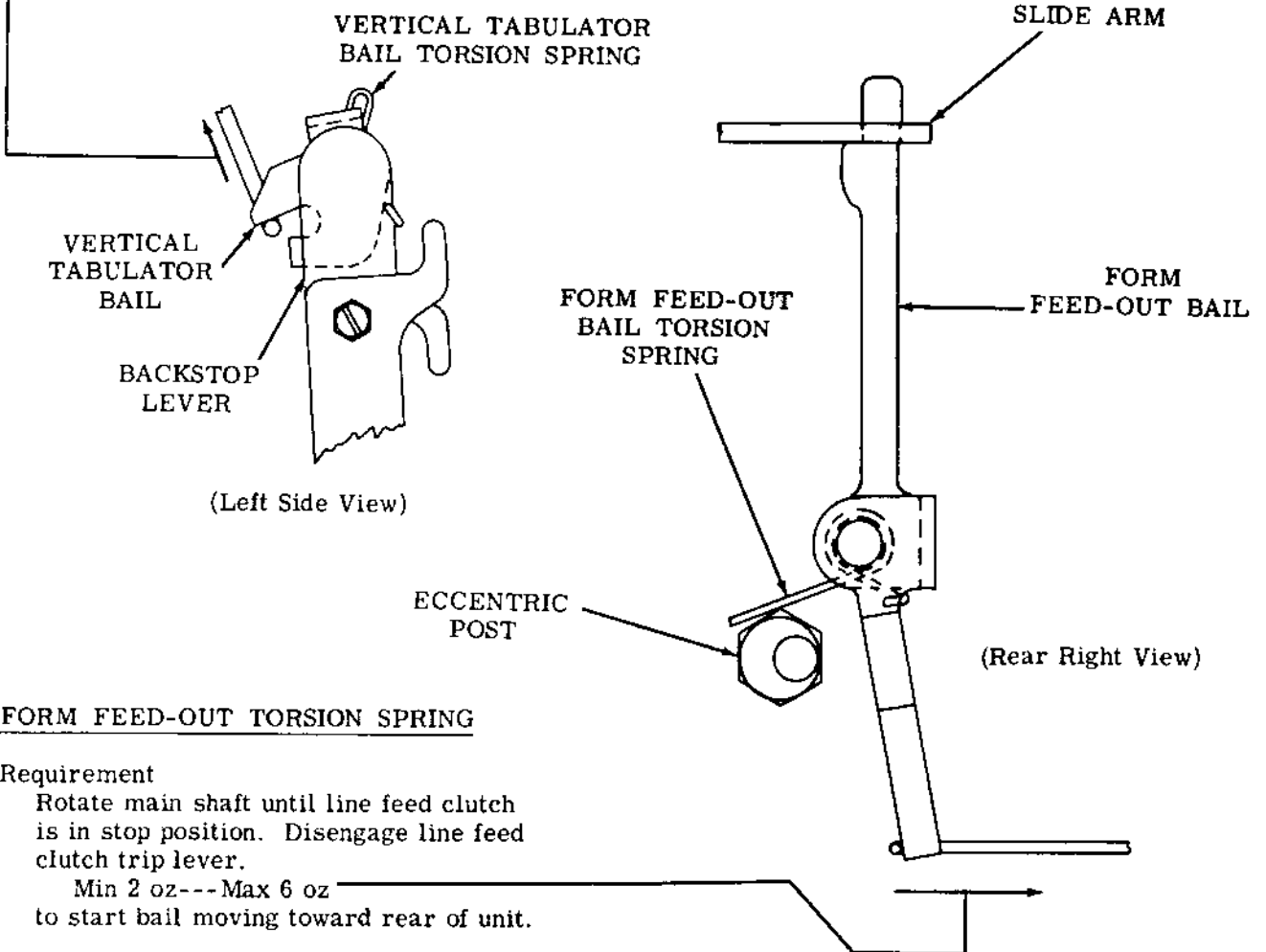

FORM FEED-OUT TORSION SPRING

Requirement

Rotate main shaft until line feed clutch is in stop position. Disengage line feed clutch trip lever.  
Min 2 oz---Max 6 oz  
to start bail moving toward rear of unit.

3.08 Form-Out Mechanism

(A) FORM-OUT LEVER BACKSTOP

Requirement

Line feed clutch trip lever against eccentric post. Form-out lever against formed extension of mounting plate. Clearance between trip lever and form-out lever

Min some---Max 0.010 inch

To Adjust

Loosen adjusting screw. Hold lower end of form-out lever against extension of mounting plate. Position upper end of form-out lever. Tighten screw.

(B) SOLENOID LEVER (See also 3.09.)

Requirement

When solenoid plunger is seated, form-out slide, through combined motions of nonrepeat slide, form-out lever and form-out bail, should have moved forward to permit form-out blocking lever to fall in behind it. Clearance between slide and blocking lever

Min 0.020 inch---Max 0.030 inch

To Adjust

Rotate eccentric screw to meet requirement. Make adjustment with high point of eccentric guide upward.

(C) FORM FEED-OUT NONREPEAT SLIDE SPRING

Requirement

Typing unit upside down and form feed-out solenoid unoperated

Min 3 oz---Max 4 oz

to pull spring to position length.

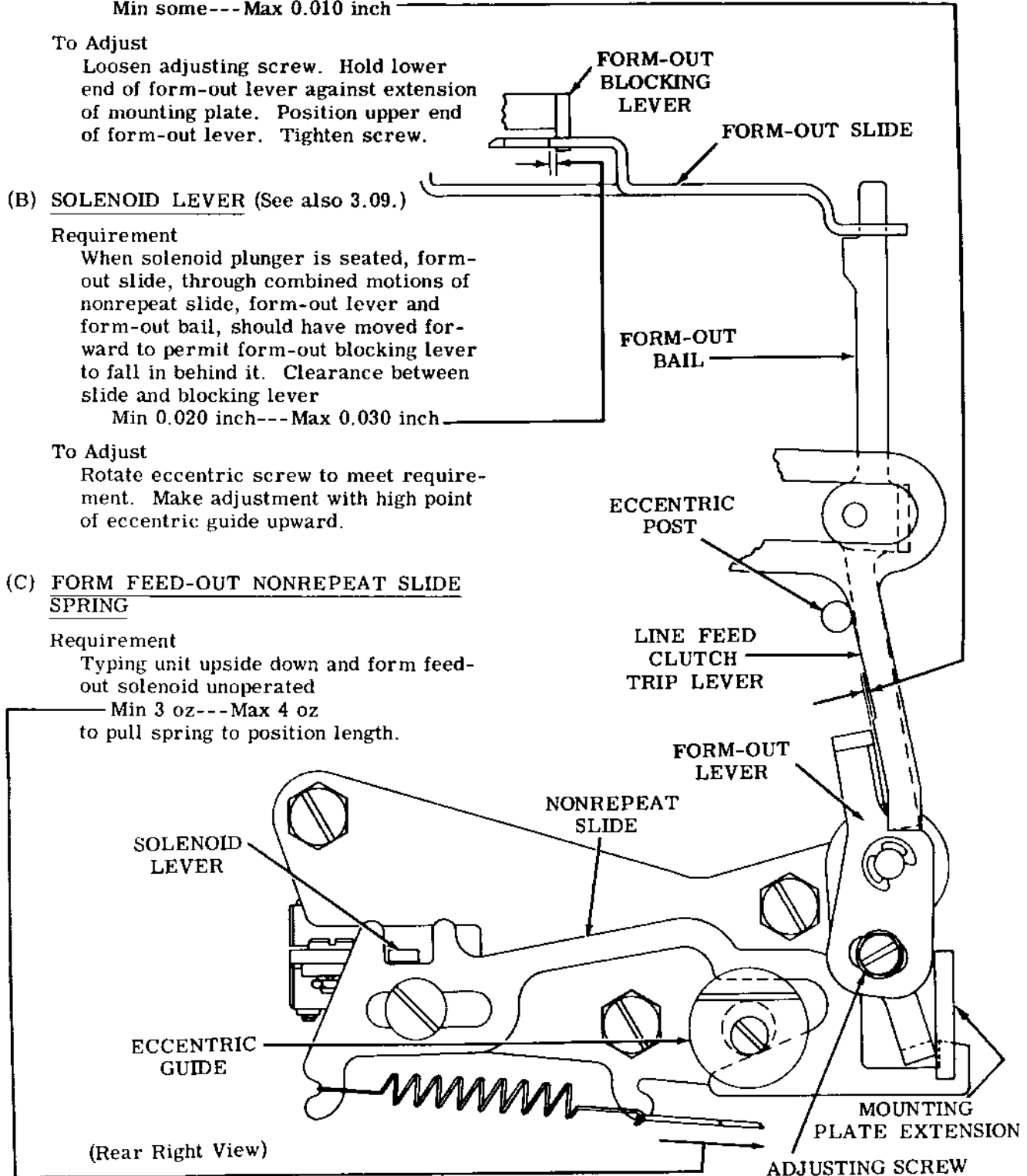

3.09 Form-Out Mechanism (continued)

Note: This adjustment insures that nonrepeat slide is stripped out of engagement with form-out lever before solenoid plunger is fully seated. It will also reduce the Min 0.020 inch--Max 0.030 inch clearance between form-out blocking lever and form-out slide, 3.08 (B), at point of stripping. Check for at least some clearance at this point. Solenoid plunger must not bind against solenoid. Loosen mounting screws and move solenoid up or down.

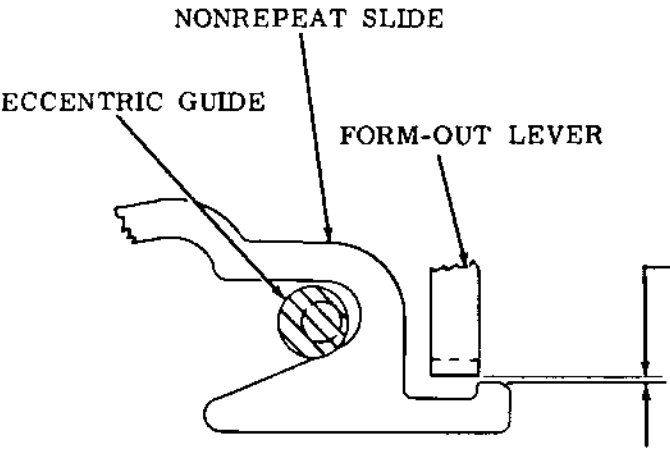
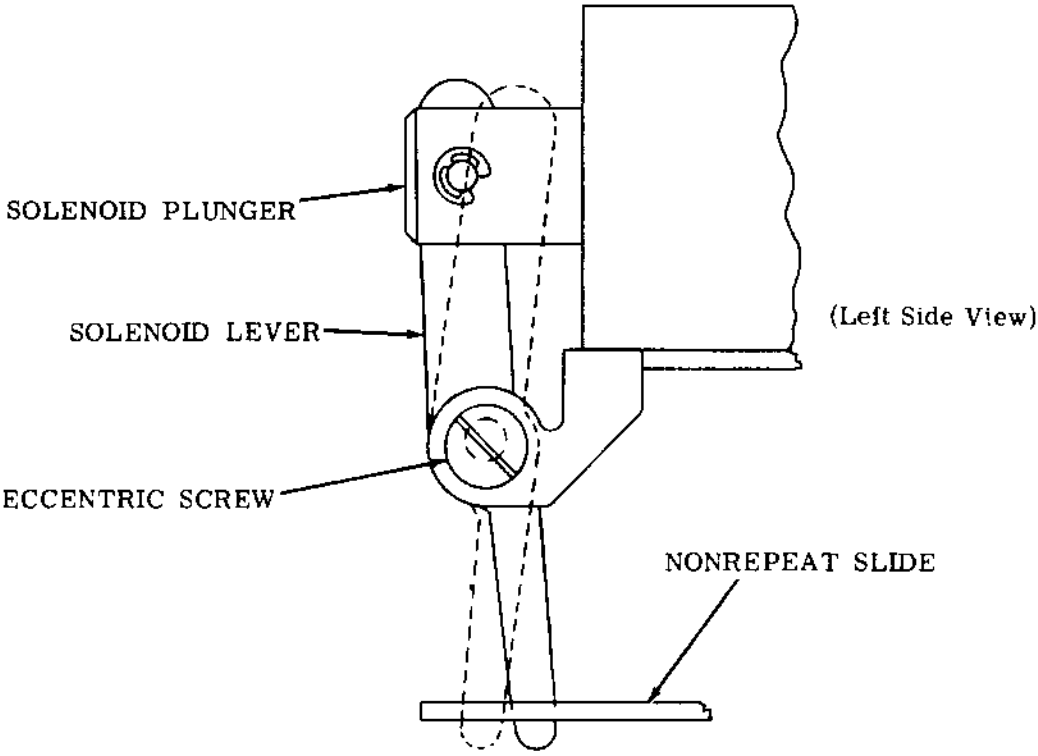

(Rear Right View)

NONREPEAT SLIDE

(See also 3.08 (B).)

Requirement  
Solenoid plunger seated. There should be some clearance between the nonrepeat slide and the form-out lever.

To Adjust  
With high point of eccentric toward front, rotate eccentric guide to meet requirement.

3.10 Low Paper and Paper Out Alarm Mechanisms

LOW PAPER AND PAPER OUT ALARM  
(SPROCKET FEED)

(1) Requirement

Without paper in unit, rear ends of switch operating levers should be in lowermost position. Switch plungers should be depressed. Normally open contacts should be closed. Ends of switch levers should be within outline of typing unit frame.

(2) Requirement

Rear ends of switch operating levers lifted to height of plane of upper surface of paper guide, switch plungers should be extended.

Min some clearance between switch levers and plungers.

To Adjust

Position plate with switch mounting plate mounting screws friction tight.

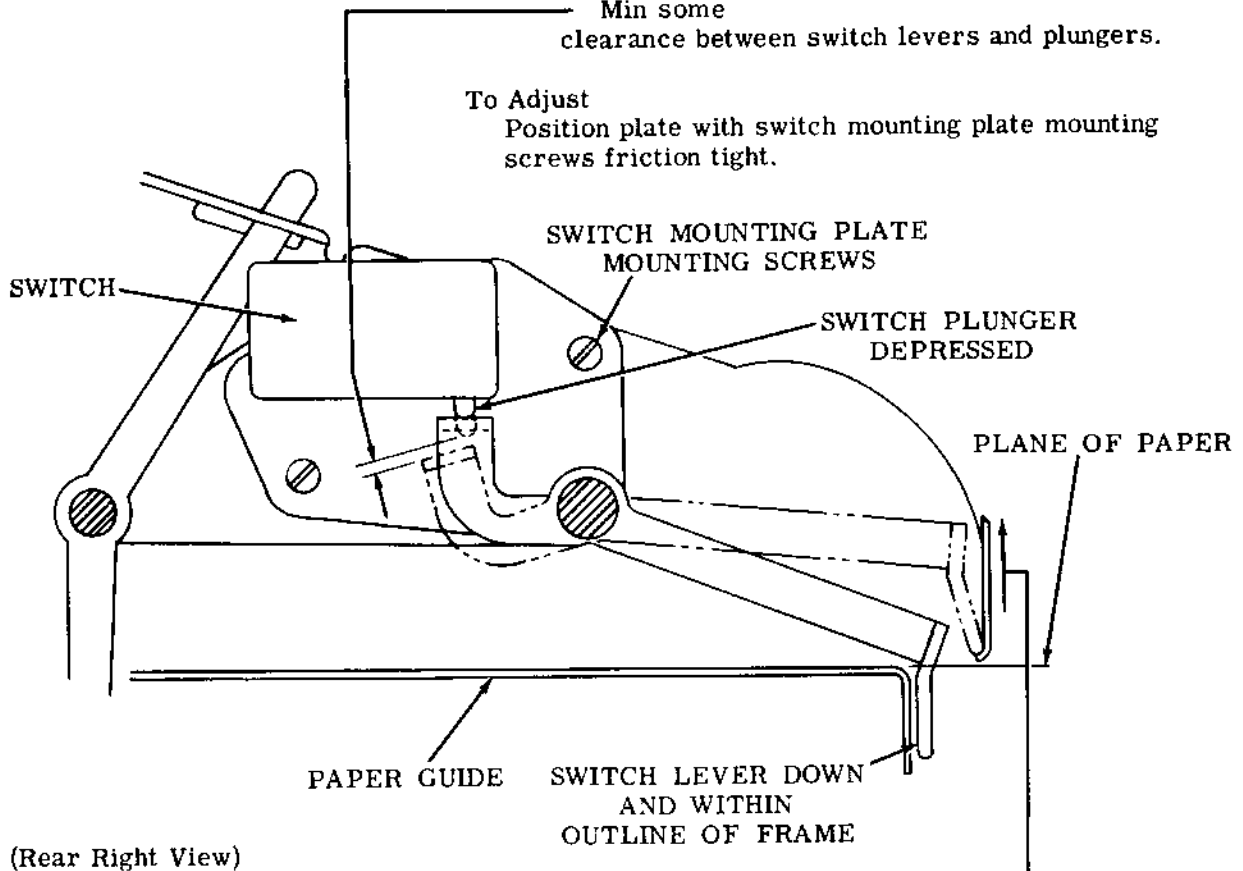

PAPER OUT ALARM SENSING LEVER SPRING  
(SPROCKET FEED)

Requirement

Min 1/2 oz---Max 1 oz \_\_\_\_\_  
to lift end of lever, which rides paper, to same plane as upper surface of paper guide. Measure both sensing lever springs in same manner.

3.11 Paper Out Alarm Mechanism (continued)  
(Friction Type) (Later Design)

Note: Adjustment requirements for the new-style paper-out alarm.

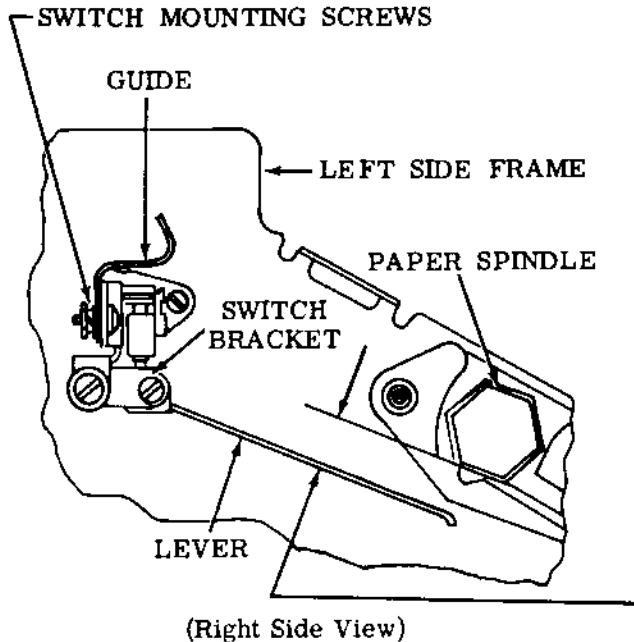

SWITCH

Requirement

Switch in uppermost position parallel to switch bracket.

To Adjust

Position switch with switch mounting screws loose.

LEVER

Requirement

Flat side of empty paper spindle parallel with upper surface of lever extension. Lever 1/4 inch below paper spindle.

To Adjust

Position bracket with post vertically up or down with mounting screws loose. If necessary, form the lever by hand.

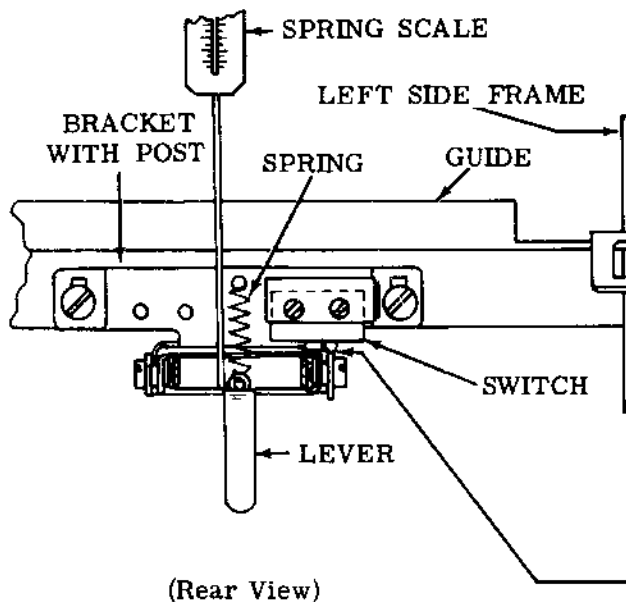

LEVER SPRING

Requirement

Spring scale applied in downward direction to lever near spring eye  
Min 11 oz---Max 18 oz  
to move switch lever clear of switch button.

3.12 Low Paper and Paper Out Alarm Mechanism (continued)

PAPER OUT ALARM BELLCRANK FOLLOWER  
SPRING (FRICTION FEED) (Early Design)

Requirement

Roll of paper removed from unit.

Min 3-1/2 oz---Max 4-1/2 oz  
to move lever far enough to just clear  
lower switch.

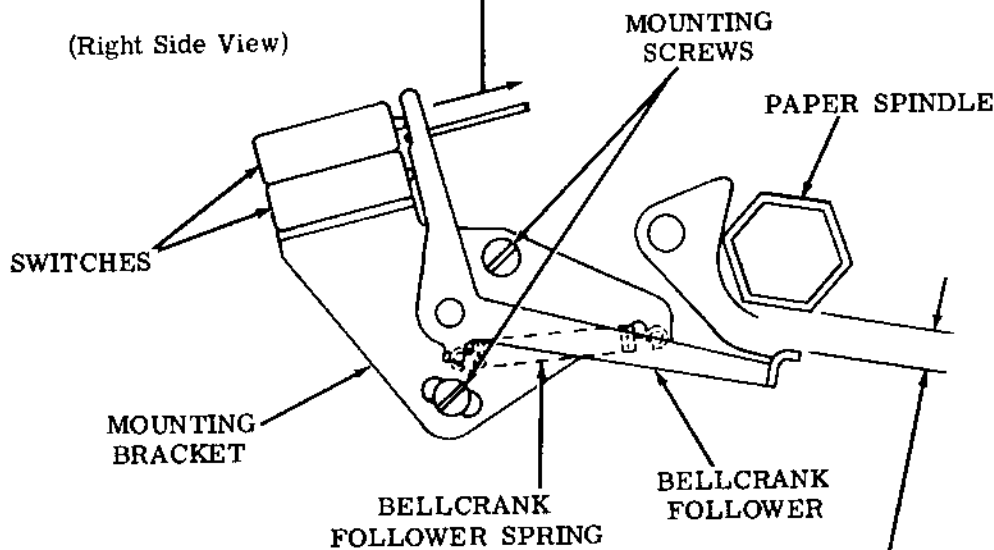

PAPER OUT ALARM ASSEMBLY (FRICTION FEED)

(1) Requirement (Early Design)

The upper switch should operate when paper  
supply is reduced to approximately  
Min 10 feet---Max 15 feet  
on the roll.

(2) Requirement

Paper follower bellcrank should operate upper  
switch at approximately 1/4 inch from flat  
side of empty paper spool.

To Adjust

Position bracket with two bracket mounting screws  
friction tight.

## 3.13 Horizontal Tabulator Mechanism

HORIZONTAL TAB OPERATING LEVER EXTENSION LINK SPRING**Requirement**

Unhook trip arm latchlever spring. Operating lever in operated position  
Slide arm against blocking lever.

Min 8-3/4 oz---Max 10-3/4 oz  
to start link moving.

Note: On units equipped with transmitter control contacts, hold contact  
spring away from stud while measuring tension.

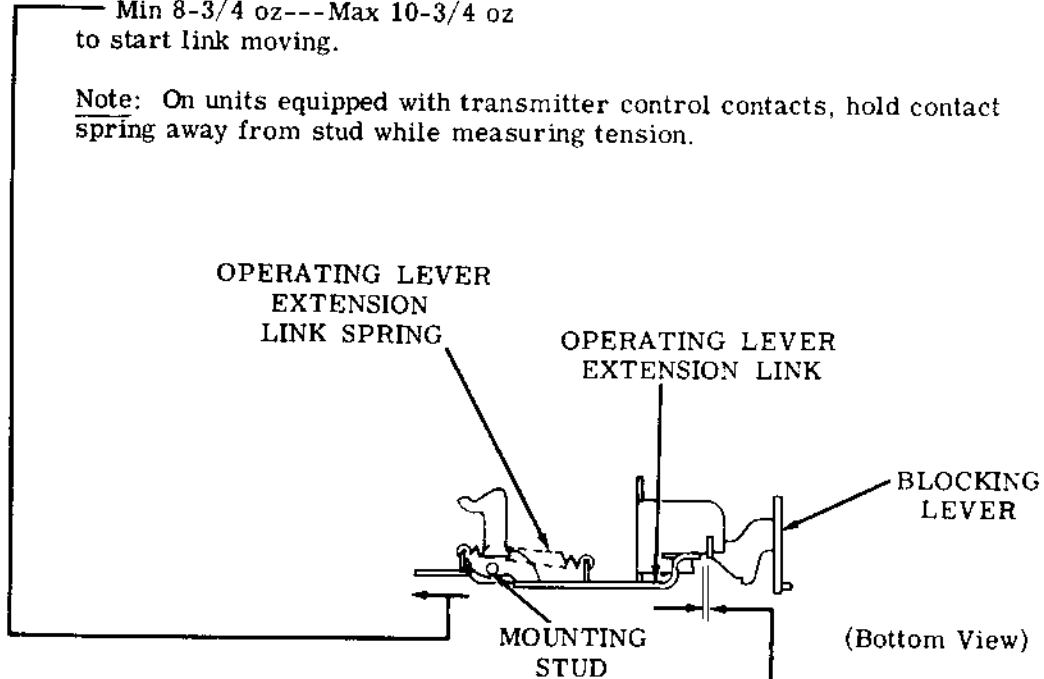
HORIZONTAL TAB OPERATING LEVER LINK**Requirement**

Rotate function clutch until function pawl stripper blade is in lower position, and function reset bail roller on high part of cam. Pull horizontal tab function pawl to rear until latched on function bar. Clearance between operating lever extension link and blocking lever

Min 0.005 inch---Max 0.025 inch  
with play taken up to minimize clearance.

**To Adjust**

Position extension link on operating lever with mounting stud friction tight.

Note: When pulling function pawl to rear, if operating lever cam plate should be stripped off the tab slide arm before function pawl is latched on function bar, temporarily disable cam plate stripper bail arm by loosening its adjusting screw.



3.14 Horizontal Tabulator Mechanism (continued)

HORIZONTAL TAB INTERMEDIATE BAIL SPRING

Requirement

Trip lever arm and intermediate bail unoperated

Min 1-1/2 oz---Max 3-1/2 oz

to pull spring to installed length.

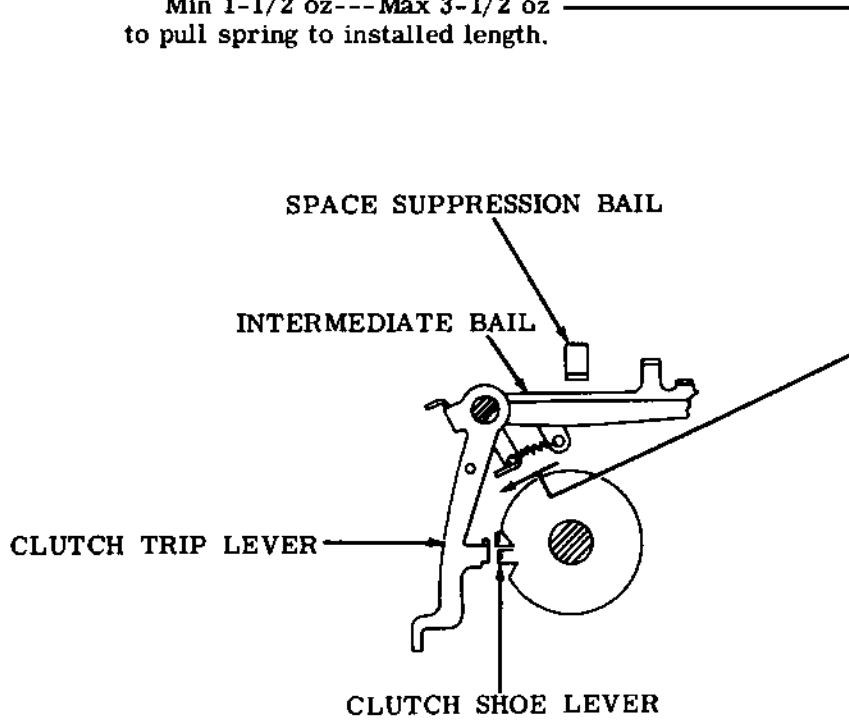

(Left Side View)

3.15 Horizontal Tabulator Mechanism (continued)

(B) HORIZONTAL TAB SPACING TRIP LEVER

Requirement

Spacing clutch trip lever arm against its stop. Operating lever against adjusting screw. Clearance between spacing trip lever and trip lever arm

Min some---Max 0.010 inch

To Adjust

Loosen mounting screw and mounting stud friction tight. With spacing trip lever riding on clutch trip lever arm, slowly rotate operating lever adjusting plate by means of screwdriver pry slots until spacing trip lever just falls off trip lever arm.

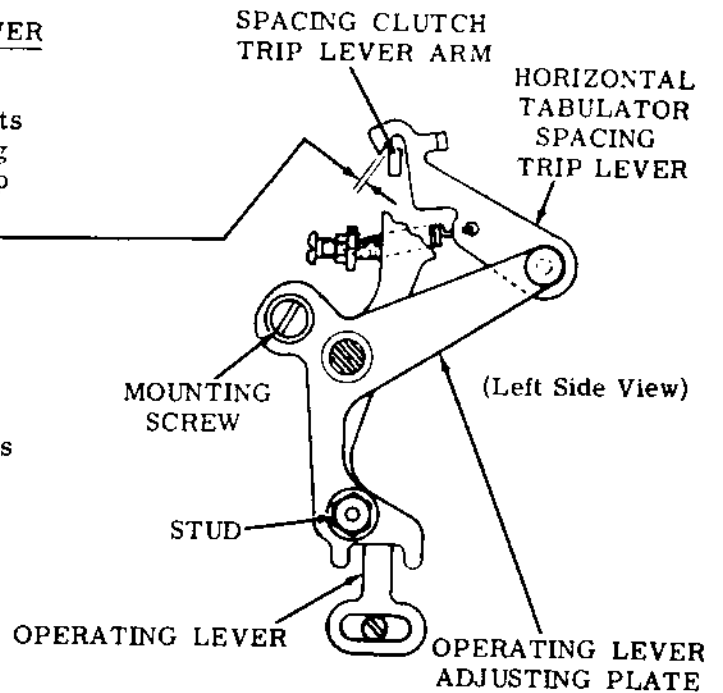

HORIZONTAL TABULATOR SLIDE ARM

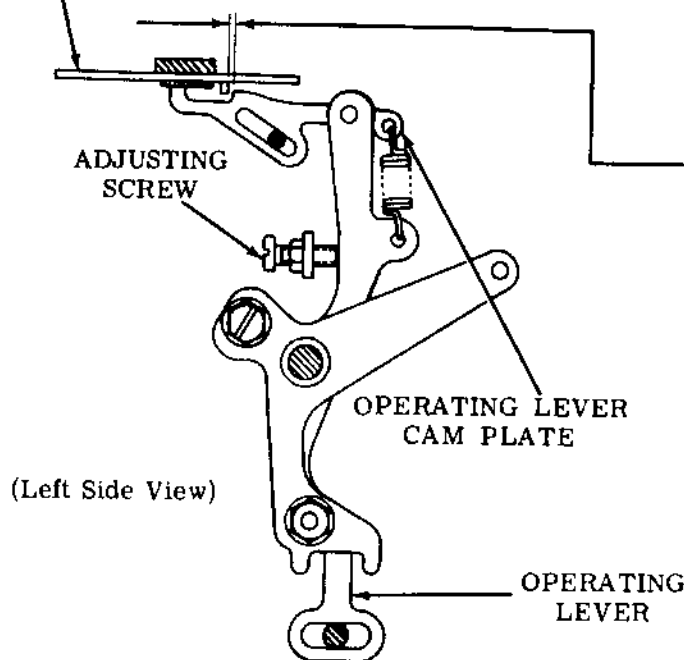

(A) HORIZONTAL TAB OPERATING LEVER CAM PLATE

(1) Requirement

Horizontal tab slide arm unoperated. Operating lever against adjusting screw. Clearance between slide arm and cam plate

Min some

(2) Requirement

With the operating lever extension link in the unoperated position, it should engage at least 2/3 of the surface of the step in the blocking lever, as gauged by eye.

To Adjust

Position adjusting screw.

3.16 Horizontal Tabulator Mechanism (continued)

HORIZONTAL TAB OPERATING LEVER  
CAM PLATE SPRING

Requirement

Operating lever unoperated.  
Horizontal tab function pawl  
unlatched.

Min 4 oz---Max 9 oz  
to start stripper bail moving.

HORIZONTAL TAB SLIDE ARM SPRING

Requirement

Operating lever operated. Slide arm  
unoperated.

Min 1-1/2 oz---Max 4 oz  
to start slide moving.

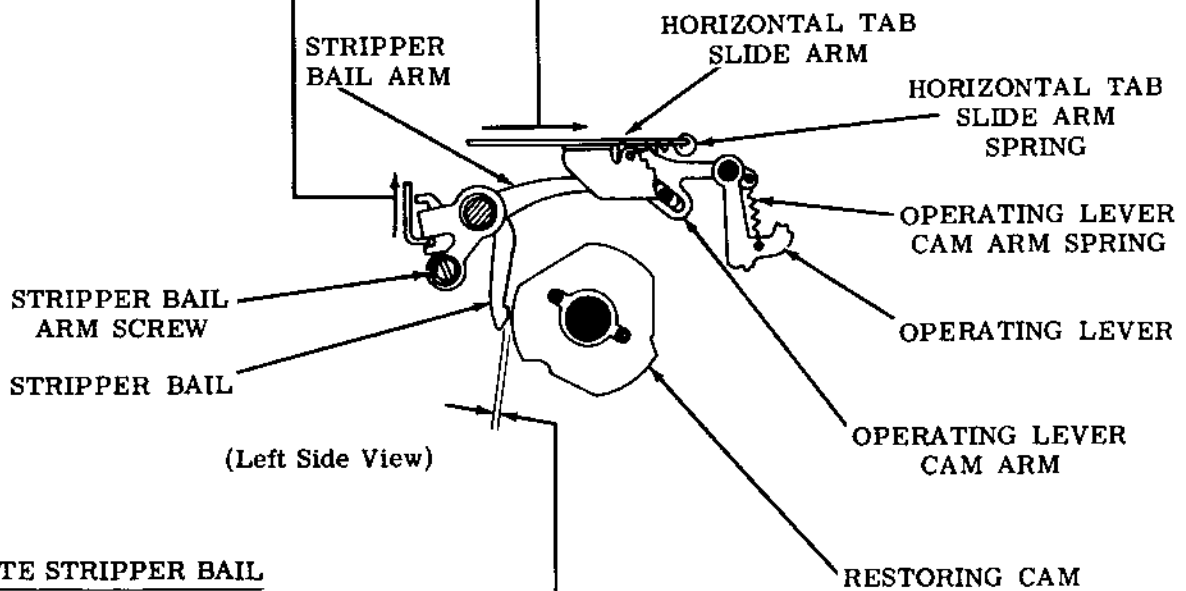

CAM PLATE STRIPPER BAIL

Requirement

Operating lever and horizontal tab  
slide arm unoperated. Rotate spacing  
clutch until high of restoring cam is  
opposite stripper bail. Clearance  
between stripper bail and high of re-  
storing cam

Min 0.010 inch---Max 0.025 inch

To Adjust

Position stripper bail on stripper  
bail arm with stripper bail arm  
screw friction tight.

3.17 Horizontal Tabulator Mechanism (continued)

(A) SPACING CUTOUT TRANSFER BAIL SET COLLAR

Requirement

Transfer bail should have  
Min some---Max 0.008 inch  
endplay.

To Adjust

Position set collar with adjusting screw  
loosened.

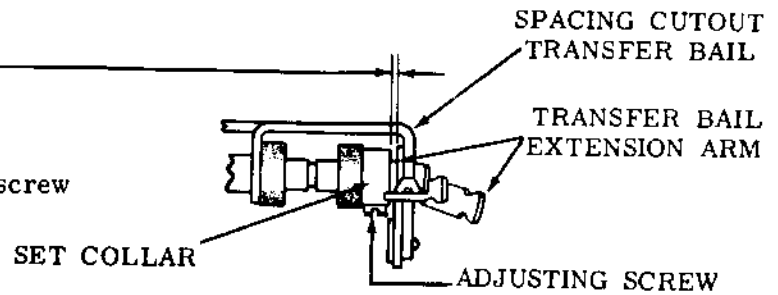

(Bottom View)

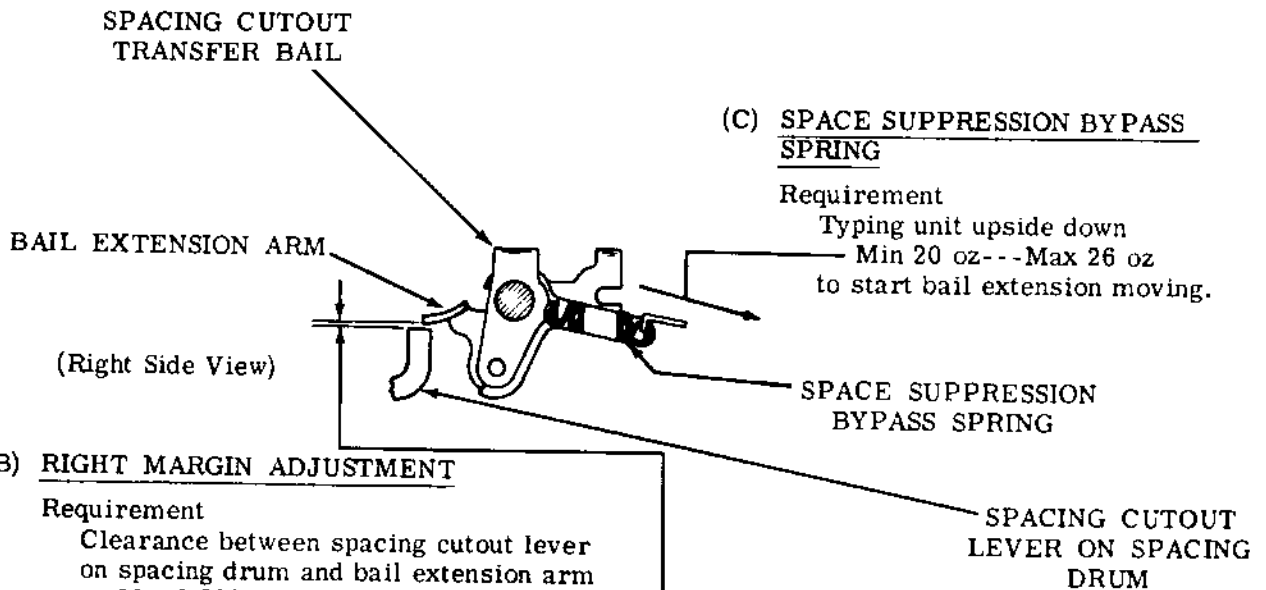

(B) RIGHT MARGIN ADJUSTMENT

Requirement

Clearance between spacing cutout lever  
on spacing drum and bail extension arm  
Min 0.006 inch---Max 0.025 inch

To Check

Place typebox in position to print character on which spacing cutout is desired. Pull forward on part of transfer bail extending below mounting shaft until bail is in fully operated position. Gauge clearance.

To Adjust

Position cutout lever with clamp screws loosened.

Note: Four screws must be loosened to adjust cutout lever (see figure in 2.56). Do not loosen hex head screw that clamps front ring.

(C) SPACE SUPPRESSION BYPASS SPRING

Requirement

Typing unit upside down  
Min 20 oz---Max 26 oz  
to start bail extension moving.

3.18 Horizontal Tabulator Mechanism (continued)

TABULATOR PAWL (PRELIMINARY)

Note: Prior to adjustment, check LEFT MARGIN (2.55) and SPACING GEAR PHASING (2.29) adjustments.

(1) Requirement

Beginning with 15th slot (counterclockwise from roller on slotted ring), position tab stops approximately an equal number of slots apart over remaining length of printing line.

To Adjust

To move stops, hook small spring hook in hole of stop. Pull tab stop straight out from spacing drum and slide it on garter spring while continuing to pull it straight out. Spacing drum may have to be rotated manually to facilitate locating stops in some slots.

**CAUTION: CHECK THAT ALL STOPS ARE FULLY SEATED IN SLOTS, AND NOT TURNED SIDWAYS.**

(2) Requirement

All clutches disengaged. Front spacing feed pawl in lower position, pawl adjusting plate should be positioned at center of vertical and horizontal adjustments.

To Adjust

Vertically position with both right and left screws loosened. Horizontally position with only left screw loosened. (Vertical adjustment is always made first.)

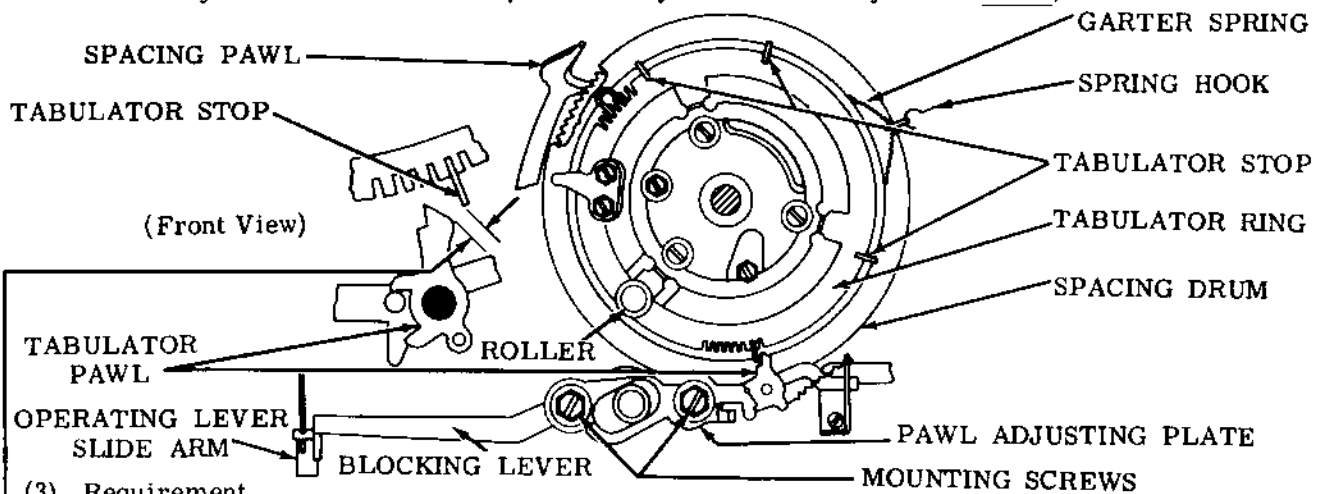

(3) Requirement

Disengage spacing feed pawls. Let spacing drum return to maximum counterclockwise position. Keep spacing clutch disengaged manually. Advance spacing drum until first stop is immediately left of pawl.

To Adjust

Adjust horizontal position of pawl adjusting plate so tabulator stop is in line with left edge of shoulder on pawl.

(4) Requirement

With blocking lever and operating lever extension link unblocked, disengage spacing feed pawls and let spacing drum move back exactly 2 full spaces. Both spacing feed pawls should be fully engaged.

To Adjust

With extension link blocked by blocking lever, gauge clearance between slope on pawl and tab stop. Note clearance. Advance drum until next stop is just left of tab pawl. Let spacing drum move back two full spaces. With extension link blocked by blocking lever, gauge and note clearance as before. Repeat procedure for remaining three stops. Note stop that gives maximum clearance. Use this stop as reference stop for final vertical and horizontal adjustments.

3.19 Horizontal Tabulator Mechanism (continued)

TABULATOR PAWL VERTICAL ADJUSTMENT (FINAL)

Requirement

Using stop with maximum clearance (determined by preliminary adjustment), position spacing drum until tab stop is opposite shoulder on tab pawl. With operating lever extension link blocked by blocking lever

Min 0.055 inch---Max 0.075 inch clearance between tab stop and tab pawl.

To Adjust

Position pawl adjusting plate with both screws loosened. Tighten right screw only, using wrench to hold bushing from turning.

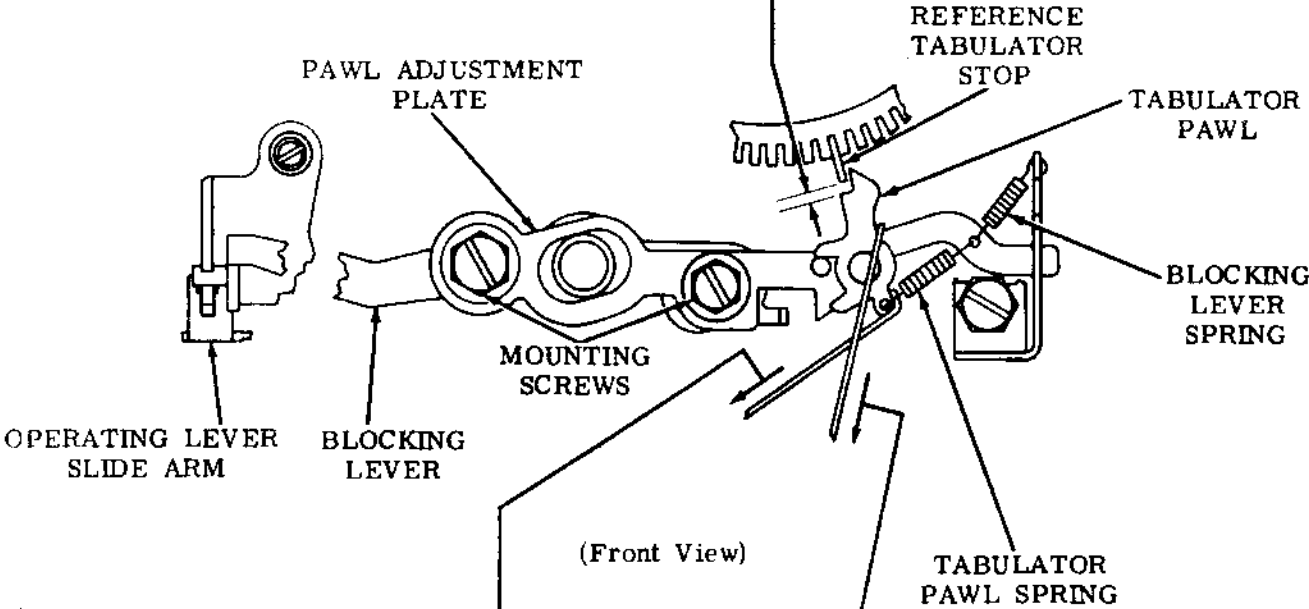

HORIZONTAL TAB PAWL SPRING

Requirement

Tab pawl unoperated  
Min 3 oz---Max 5 oz  
to start pawl moving.

HORIZONTAL TAB BLOCKING LEVER RETURN SPRING

Requirement

Operating lever slide arm held to rear  
Min 2-1/2 oz---Max 4-1/2 oz  
to start lever moving.

3.20 Horizontal Tabulator Mechanism (continued)

TABULATOR PAWL HORIZONTAL ADJUSTMENT

Requirement

All clutches disengaged. Front spacing feed pawl in lower position. Position spacing drum so tab stop with maximum clearance (as determined by preliminary adjustment) is immediately left of pawl. Operating lever extension link forward in unblocked position. Disengage feed pawls, let spacing drum move back one full space. Both feed pawls should be fully engaged. Pull back extension link to blocked position on blocking lever. Trip spacing clutch stop lever and slowly rotate main shaft and spacing clutch until blocking lever is just tripped, allowing extension link to move forward. At this point, some portion of clutch disc stop-lug should be aligned with rear surface of spacing shaft gear. Take up play in spacing shaft towards rear of unit.

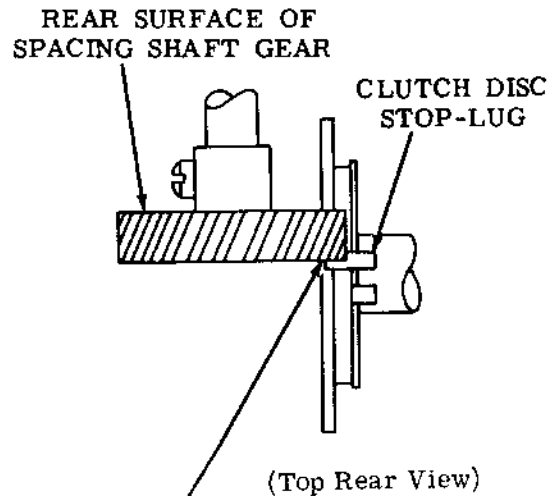

To Adjust

Trip spacing clutch and rotate clutch until middle of stop-lug is in line with rear surface of spacing shaft gear. If blocking lever trips too soon, first adjust the pawl adjusting plate to left until blocking lever can be placed in blocked position on extension link. Slowly move adjusting plate to right, with left screw loosened, until blocking lever just trips. When adjusting for trip-off point, take care that blocking lever is cammed down by tab stop and not pulled or pushed out of blocked position when prying adjusting plate. Recheck trip-off point against position of clutch stop-lug as before.

Note: After obtaining trip-off point of blocking lever, continue rotating spacing clutch to full stop position. Tab pawl should be right of tab stop. When extension link is moved to rear, blocking lever should move to blocked position. If tip of pawl should remain on end of tab stop, readjust pawl to right until there is

Min 0.003 inch--Max 0.008 inch  
 \_\_\_\_\_  
 clearance between right surface on tab stop and left edge on pawl tip.

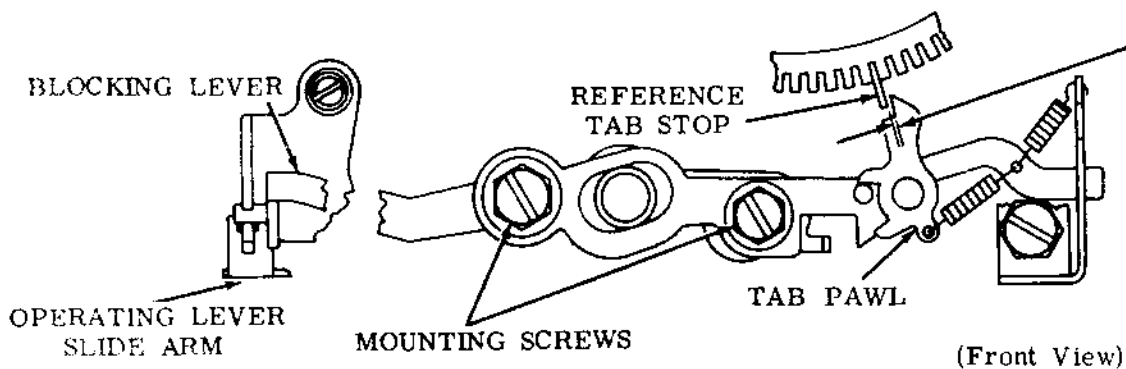

## 3.21 Horizontal Tabulator Mechanism (continued)

(C) RIGHT MARGIN TABULATOR STOP  
(WITH WIDE SHELF)**Requirement**

Check right margin and tabulator pawl adjustments. Position printing carriage at right margin (spacing cutout operated). Insert stop with wide shelf in slot immediately to left of pawl. Shelf should extend to right so pawl rests on it.

(A) TABULATOR STOPS SETTING**Requirement**

To move stops, hook small spring hook in hole in stop and pull straight out from drum. Slide stop on spring while continuing to pull out from drum. Position drum to facilitate moving stops.

**CAUTION: CHECK TO INSURE THAT ALL STOPS ARE FULLY SEATED IN SLOTS, AND NOT TURNED SIDEWAYS.**

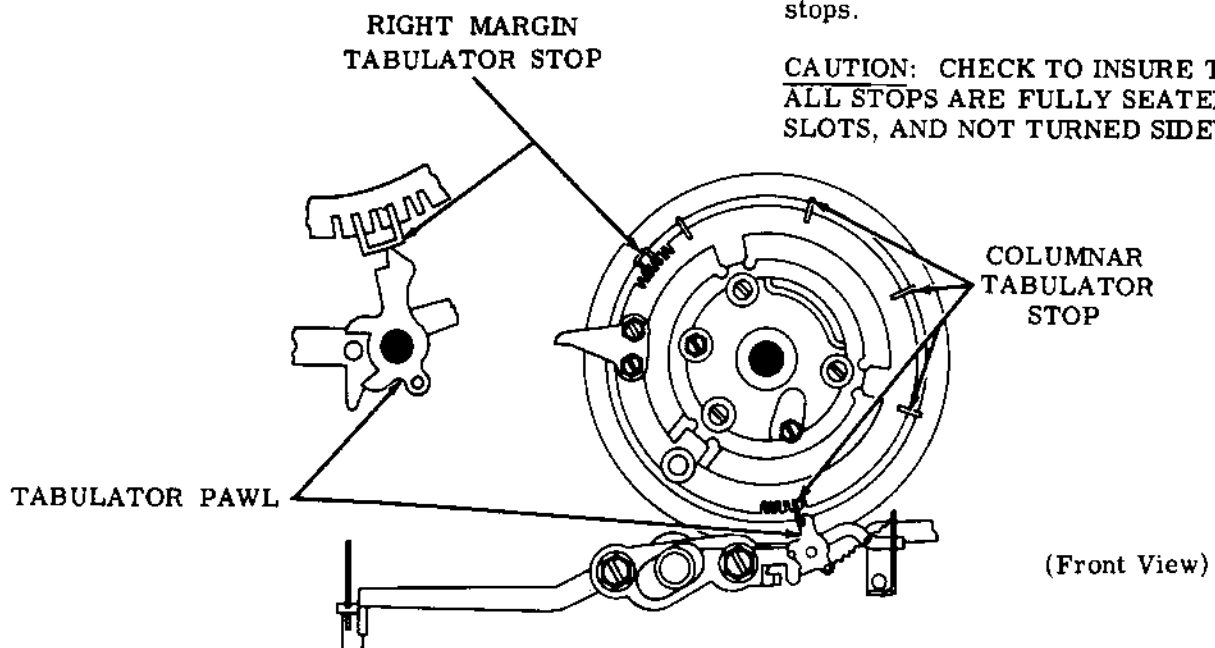
COLUMNAR TABULATOR STOPS**Requirement**

Place carriage in position to print first character in column. Insert stop in slot immediately to left of tab pawl. To facilitate installation, mark desired slot position, rotate drum to a more accessible position. For slots near left margin, count number of space operations from left margin and place stop in corresponding slot number, beginning with slot no. 1 just to right of roller.

**Note:** When printing forms, check stop settings with relation to columns. Corresponding stops on all machines connected in a circuit must be same number of spacing operations from left margin.



3.22 Transmitter Distributor Transfer Control Contacts

(D) CONTACT ASSEMBLY BRACKET (PRELIMINARY)

Requirement (Not Illustrated)  
Operating lever unoperated. Clearance between stud on operating lever and long contact spring  
Min 0.020 inch---Max 0.025 inch

To Adjust  
Position contact assembly bracket with mounting screws loosened. The bracket pivots about a pin at upper end of bracket.

(E) TRANSMITTER CONTROL CONTACT GAP

Requirement (Not Illustrated)  
Operating lever in operated position.  
Min 0.010 inch---Max 0.015 inch between normally closed contacts.

To Adjust  
Bend stiffener.

(B) NORMALLY OPEN CONTACT SPRING

Requirement  
Operating lever unoperated  
Min 1 oz---Max 2 oz  
to just move short contact spring away from stiffener.

To Adjust  
Bend short contact spring.

(C) NORMALLY CLOSED CONTACT SPRING

Requirement  
Operating lever operated.  
Min 2 oz---Max 3 oz  
to just move short contact spring away from stiffener.

To Adjust  
Bend short contact spring.

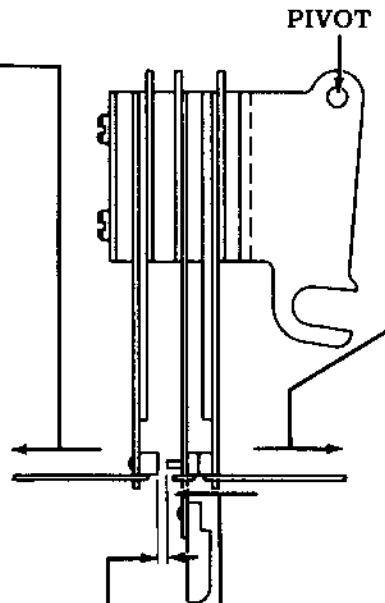

(F) NORMALLY OPEN CONTACT GAP

Requirement  
Operating lever unoperated.  
Min 0.010 inch---Max 0.015 inch  
between normally open contacts.

To Adjust  
Bend stiffener.

(A) TRANSFER CONTACT SPRING

Requirement  
Operating lever unoperated.  
Min 2-1/2 oz---Max 3-1/2 oz  
to just open contacts.

To Adjust  
Bend long contact spring.

(G) CONTACT ASSEMBLY BRACKET (FINAL)

Requirement  
Operating lever unoperated. There should be some clearance between stud on operating lever and long contact spring.

To Adjust  
Remake adjustments (D), (E) and (F).

3.23 Transmitter Distributor Transfer Control Contacts (Later Design)

(A) TRANSFER CONTACT SPRING

Requirement

With the operating lever in the unoperated position, hook scale over the transfer contact swinger and pull at right angle to it.

Min 2 oz---Max 3 oz  
to just open the contacts.

To Adjust

Bend the contact swinger spring.

(B) NORMALLY OPEN CONTACT SPRING

Requirement

With the operating lever in the unoperated position, hook scale over the short contact spring just above the contact point and pull at right angles to it.

Min 1 oz---Max 2 oz  
to just move the short contact spring away from the stiffener.

To Adjust

Bend the short contact spring.

(C) CONTACT SPRING

Requirement

With the transfer contact swinger held away from the extension of the long contact spring, hook scale over the extension and pull at right angles to it.

Min 2 oz---Max 3 oz  
to separate the contact points.

To Adjust

Bend the long contact spring.

(D) CONTACT ASSEMBLY BRACKET (PRELIMINARY)

Requirement

With the operating lever in the unoperated position, there should be Min 0.020 inch---Max 0.025 inch between the stud on the operating lever and the long contact spring.

To Adjust

Position the contact assembly bracket with the mounting screw loosened. The bracket pivots about a pin at the upper end of the bracket.

(E) NORMALLY OPEN CONTACT GAP

Requirement

With the operating lever in the unoperated position, there should be Min. 0.012 inch---Max 0.020 inch between the normally open contacts.

To Adjust

Bend the stiffener.

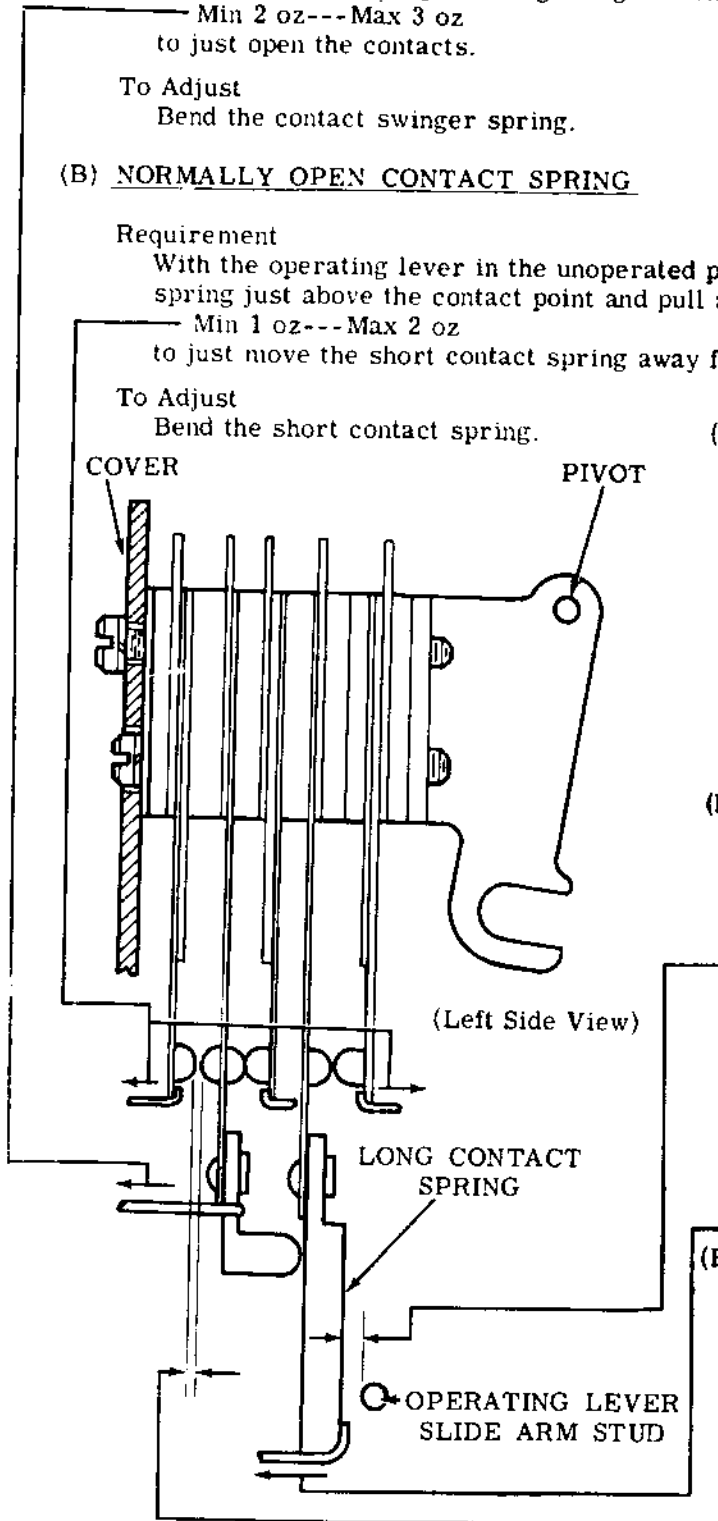

3.24 Transmitter Distributor Transfer Control Contacts (continued)

(A) TRANSMITTER CONTROL CONTACT GAP

Requirement

With the operating lever in the operated position, there should be  
Min 0.010 inch---Max 0.015 inch  
between the normally closed contacts.

To Adjust  
Bend the stiffener.

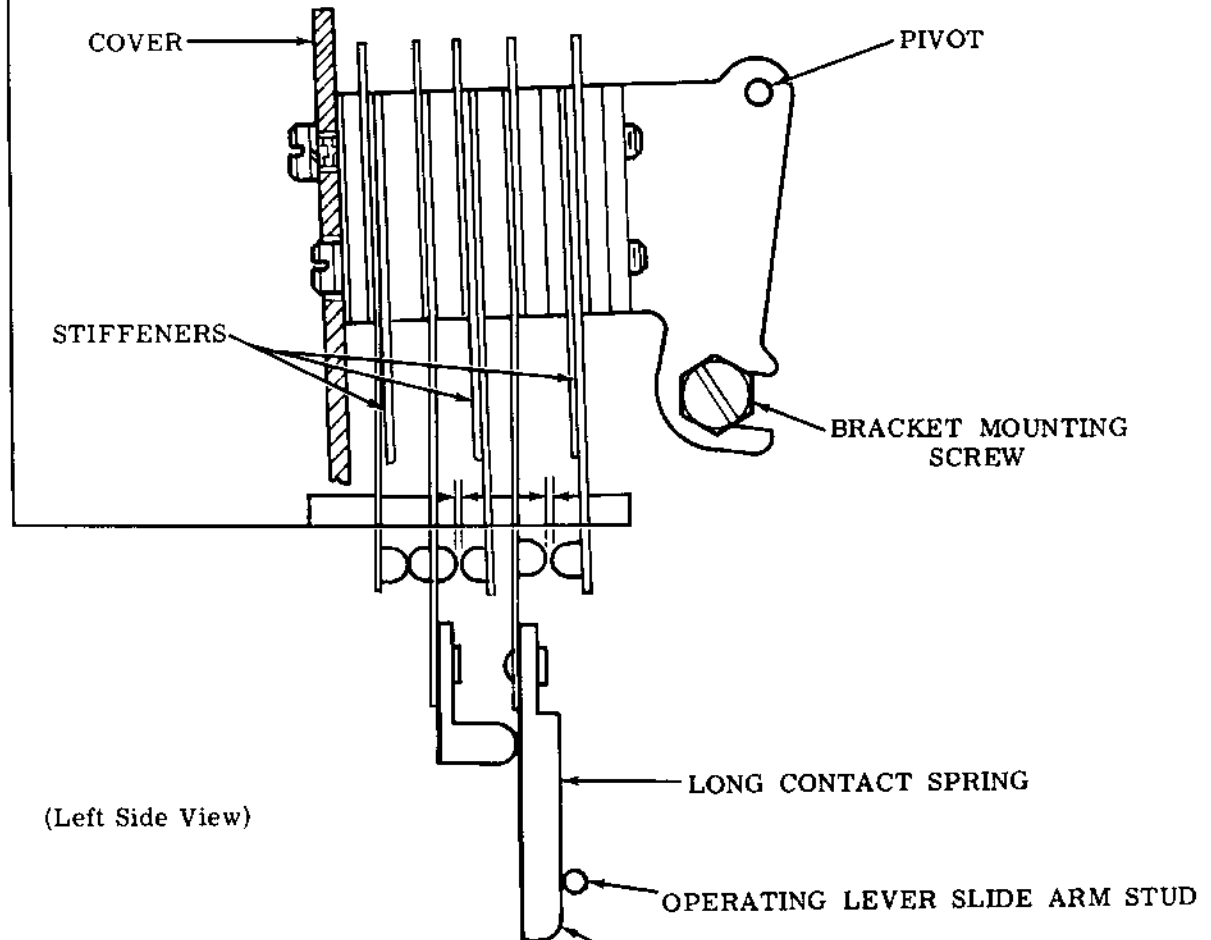

(B) CONTACT ASSEMBLY BRACKET (FINAL)

Requirement

With the operating lever in the unoperated position, there should be some clearance between the stud on the operating lever and the long contact spring.

To Adjust

Remake TRANSFER CONTACT SPRING (3.23) and TRANSMITTER CONTROL CONTACT GAP adjustments.

3.25 Keyboard Lock Mechanism

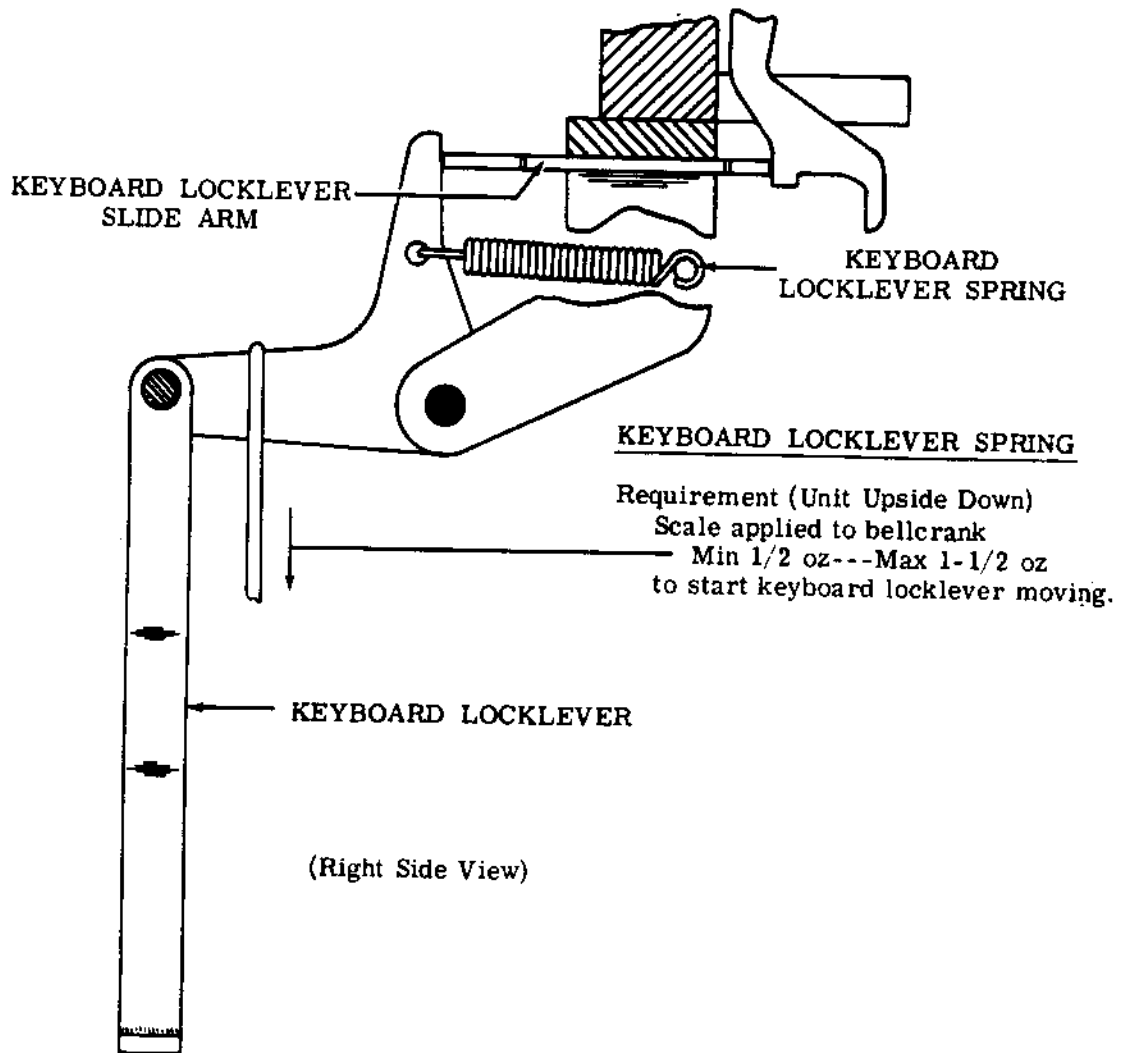

3.26 Local Backspace Mechanism

CAMMING BAIL STOP ARM

Requirement

Spacing clutch disengaged, front feed pawl in lower position, backspace bail held operated, clutch tripped and main shaft rotated until the front feed pawl tooth is opposite the peak of the first spacing drum tooth that moves down past the pawl tooth. Clearance between pawl tooth and the tooth on the spacing drum ratchet wheel

Min 0.020 inch---Max 0.035 inch

To Adjust

Position the adjusting plate on the intermediate arm in the center of its adjusting range. Then position the camming bail stop arm with its mounting screw friction tight to meet the requirement.

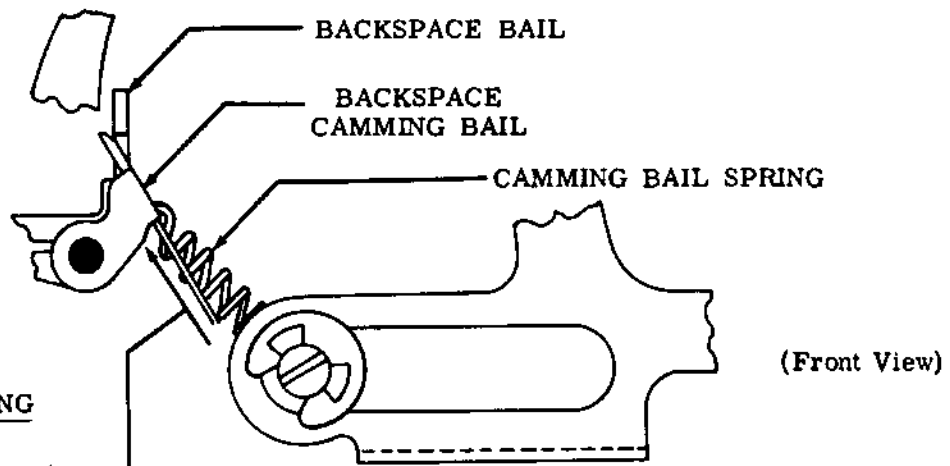
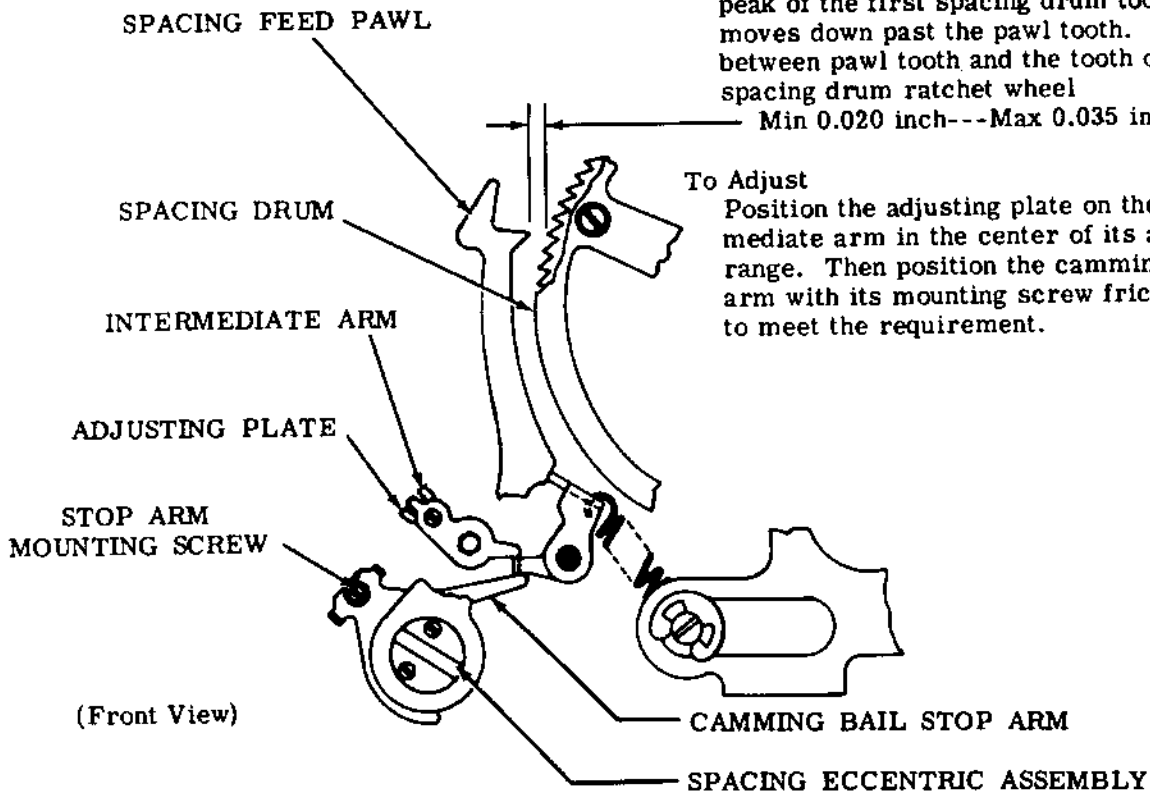

CAMMING BAIL SPRING

Requirement

Min 1 oz---Max 2-1/4 oz to start bail moving.

Note: See appropriate section for related keyboard adjustments.

3.27 Vertical Tabulator Mechanism

(C) FORM START GEAR PLAY

Requirement

Barely perceptible backlash between idler gear and form start gear.

To Adjust

Position gear pivot post with nut loosened.

Note: Gears should mesh accurately when checked at 3 equal distances around circumference of gear.

(E) INDEXING DISC

Requirement

Clearance between form-out stop plate and follower should be

Min 0.020 inch---Max 0.040 inch

To Check

Line feed clutch disengaged. Stop plate adjacent to follower. Slack in gears taken up to make gap a maximum.

To Adjust

Pull gear out of engagement with idler gear. Turn hand wheel clockwise until stop plate just operates the follower, then engage first tooth on idler. Position indexing disc with three mounting screws loosened.

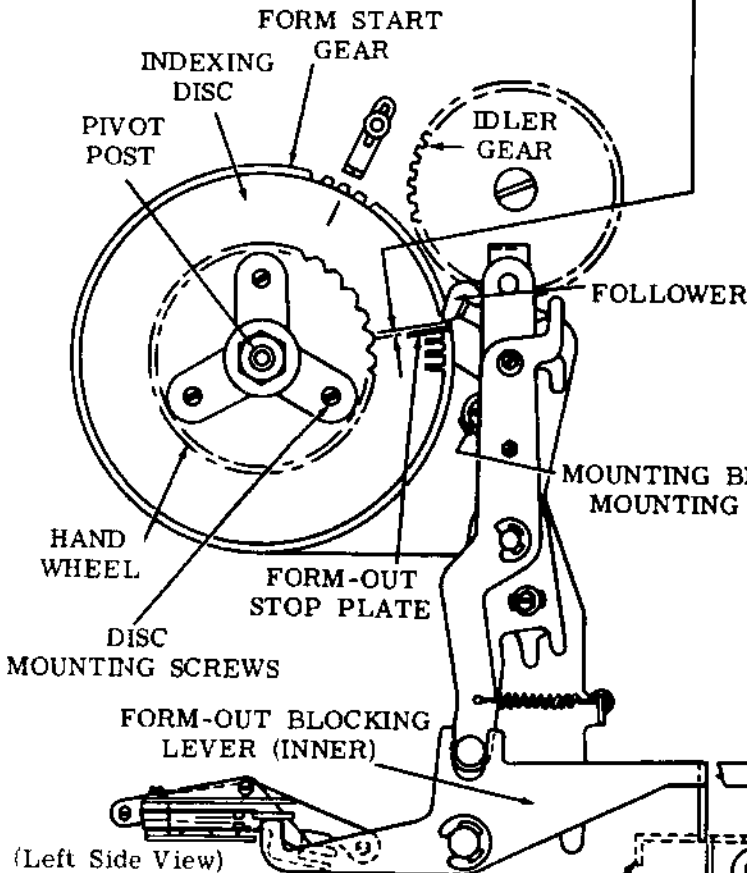

(D) BLOCKING LEVER

See 3.28.

(A) VERTICAL TABULATOR SLIDE RETAINER

Requirement

Clearance between vertical tab slide and retaining edge of retainer should be

Min some---Max 0.012 inch

To Adjust

Position retainer forward and locate it up or down with mounting screws loosened.

(B) MOUNTING BRACKET

(1) Requirement

Clearance between form-out blocking lever (inner lever) and form-out slide

Min some---Max 0.020 inch

To Check

Select FORM-OUT (CONTROL L) code combination, hold stripper slide bail to the rear of unit and rotate main shaft until form-out slide is in most forward position. Take up play in form-out blocking lever to make clearance minimum.

(2) Requirement

Clearance between vertical tab slide and vertical tab blocking lever (outer lever)

Min 0.002 inch

To Check

Select VERTICAL TAB (CONTROL K) code combination, hold stripper bail to rear of unit and rotate main shaft until vertical tab slide is in most forward position. Take up play in vertical tab blocking lever to make clearance minimum.

To Adjust

Position lower portion of mounting bracket with mounting screws loosened.

3.28 Vertical Tabulator Mechanism (continued)

(I) FORM-OUT STOP PLATE POSITION

Requirement

Place a form-out stop plate in the numbered slots on disc corresponding to length of page form to be used. Synchronize form-out device with a form by positioning form so that typing unit will print in first typing line of the form. When typing unit is in stop position, top of ribbon guide should align with bottom of printing line.

To Position

With page form in desired position, disengage form-stop gear from its idler gear. Rotate form-start gear until notch in indexing disc aligns with pointer on side of printer. Re-engage gears.

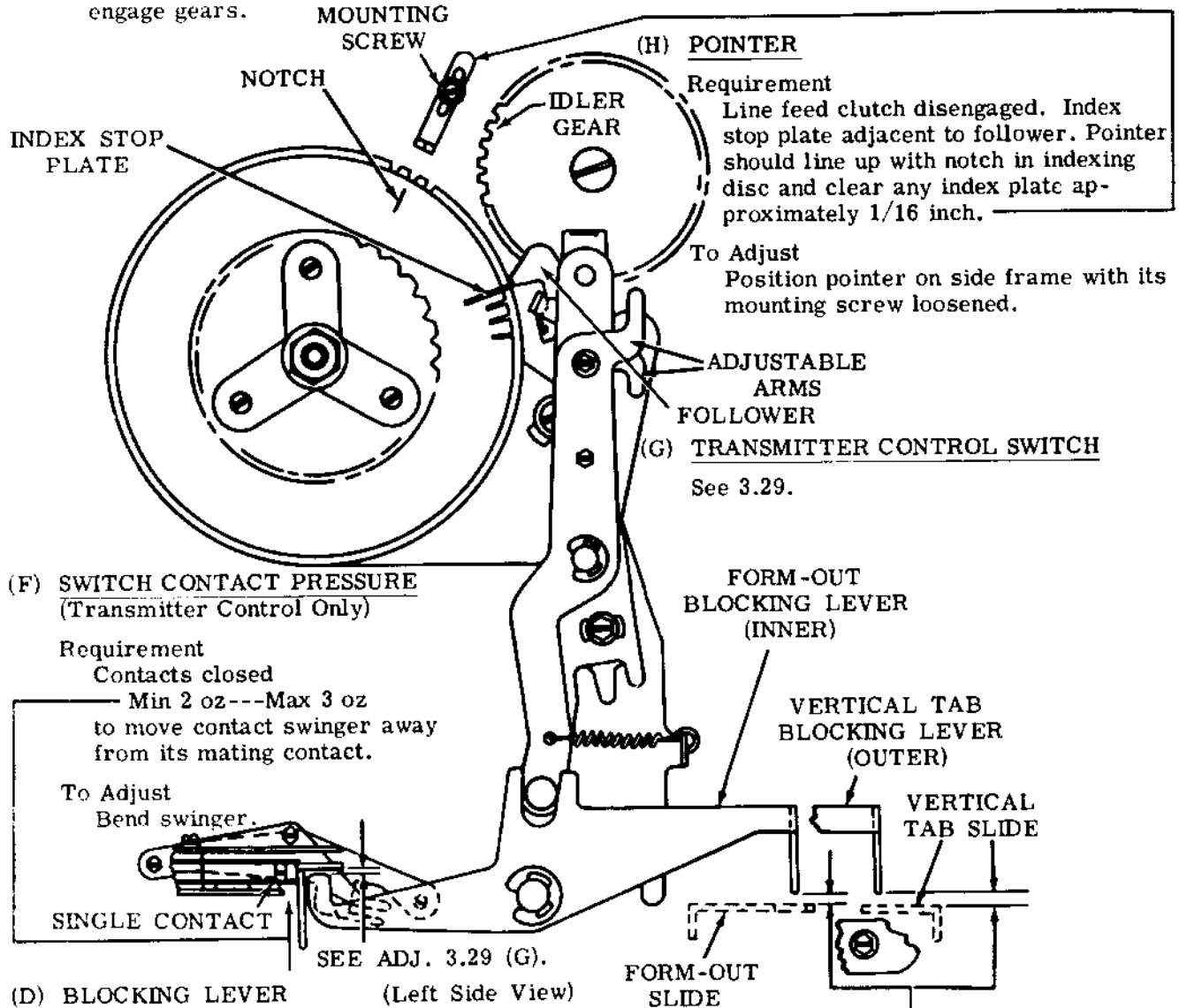

3.29 Vertical Tabulator Mechanism (continued)

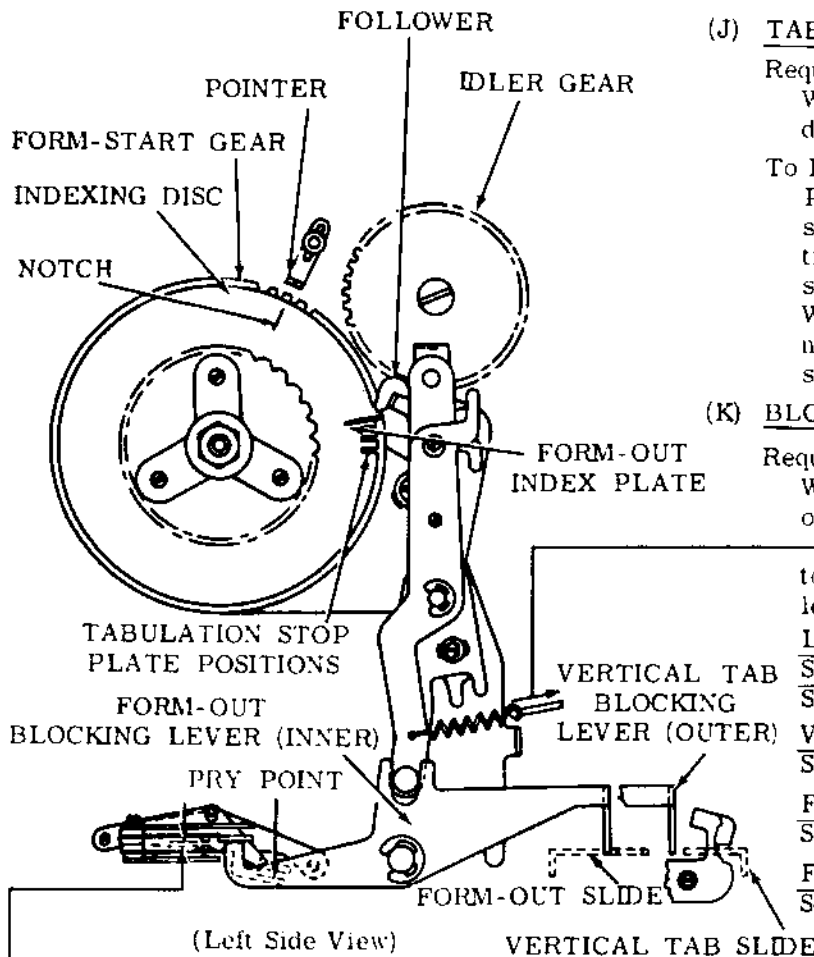

(J) TABULATION STOP PLATE POSITION

Requirement

With adjustment (I) met, line feed platen to desired first line of printing in that form.

To Position

Place tabulation stop plate in index disc slot to align with follower. Install additional tab stop plates at succeeding desired printing lines within the form. When tabulation at a given point is not needed, rotate tab stop plates on their sides.

(K) BLOCKING LEVER SPRING

Requirement

With spring unhooked and blocking lever on top of slide.

Min 9 oz---Max 11 oz to pull respective spring to position length.

LINE FEED CLUTCH TRIP LEVER SPRING

See 2.23.

VERTICAL TAB BAIL SPRING

See 3.07.

FORM-OUT PAWL SPRING

See 3.07.

FUNCTION CONTACT SPRING

See 2.65.

(G) TRANSMITTER CONTROL SWITCH (SINGLE CONTACT TYPE)

(1) Requirement

With control contacts open clearance between contacts should be Min 0.010 inch---Max 0.020 inch

To Check

Select form-out code. Rotate main shaft until form-out slide is in most forward position and form-out blocking lever drops behind its slide.

(2) Requirement

Same as Requirement (1)

To Check

Select vertical tab code. Rotate main shaft until vertical tab slide is in most forward position and vertical tab blocking lever drops behind its slide.

(3) Requirement

With transmitter control contacts closed, there should be some clearance between insulator tip of swinger and lobes of both form-out and vertical tab blocking levers. (See figure in 3.28.)

To Check

Rotate main shaft until both form-out and vertical tab blocking levers are resting on top of slides.

To Adjust

Position switch assembly at pry point with center mounting screw loosened.



3.30 Transmitter Control Contacts (Later Design)

(A) SWITCH CONTACT PRESSURE

Requirement

With the break (lower) contacts closed and the make contacts open, it should require

Min 20 grams---Max 25 grams  
to move the contact swinger away from its mating break contact.

To Adjust

Bend the swinger until the requirement is met.

(B) NORMALLY OPEN CONTACT GAP

Requirement

The contact gap between the swinger and the make (upper) contact should be

Min 0.008 inch---Max 0.020 inch

To Adjust

Bend the make contact spring until the requirement is met.

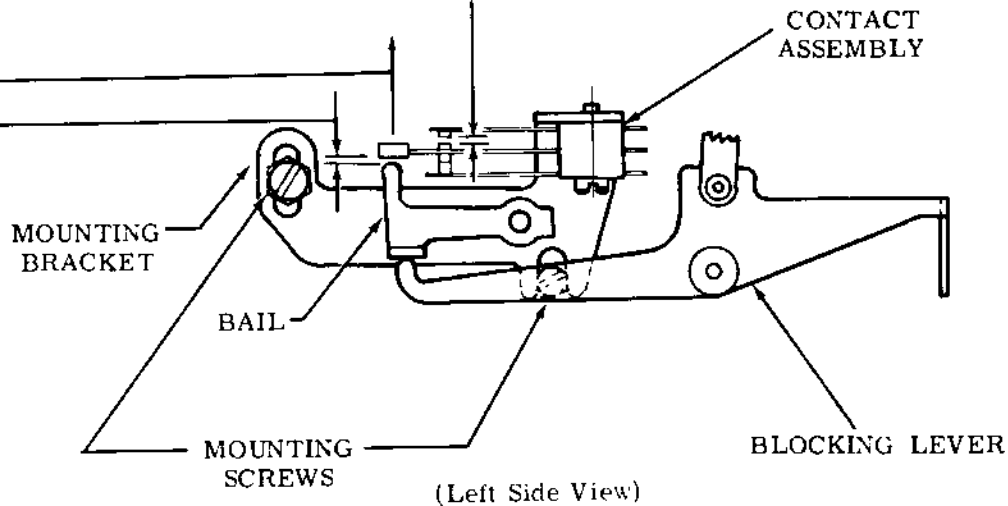

(C) CONTACT BRACKET

Requirement

Rotate the main shaft until both the form-out and vertical tab blocking levers are unoperated (resting on top of the slides). The transmitter control contacts (lower set) should be closed and there should be

Min 0.005 inch---Max 0.015 inch  
between the insulator pad of the swinger and the lobe of the bail.

To Adjust

With mounting screws friction tight, position mounting bracket. Tighten screws.

3.31 Upper Solenoid (For Applicable Units)

UPPER SOLENOID

Requirement

With the solenoid held in the energized condition, position the solenoid so that there is

Min 0.060 inch---Max 0.080 inch  
between the solenoid bail stop and the codebar detent housing.

Note: Take up play in bail to the left to make this clearance a maximum.

To Adjust

Loosen the two solenoid adjusting screws and position the solenoid to meet the requirement.

To Check

Apply 110 volts ac to the solenoid. If the solenoid buzzes, the suppression bar is stopped before the solenoid is in its proper energized condition. Refine above.

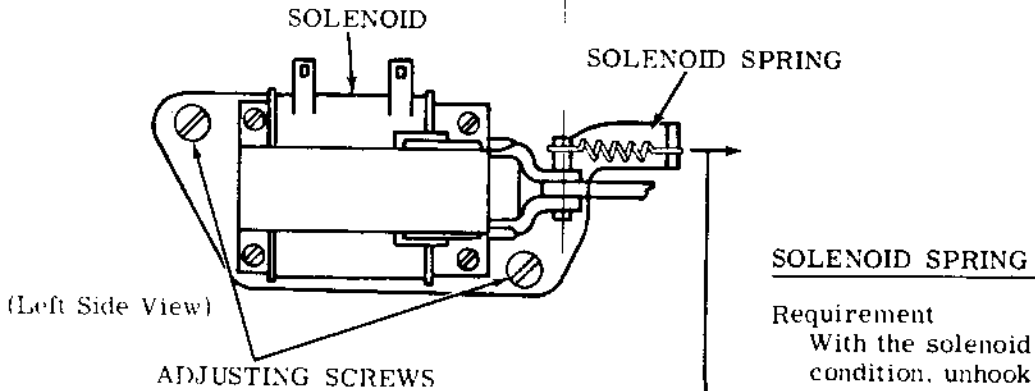
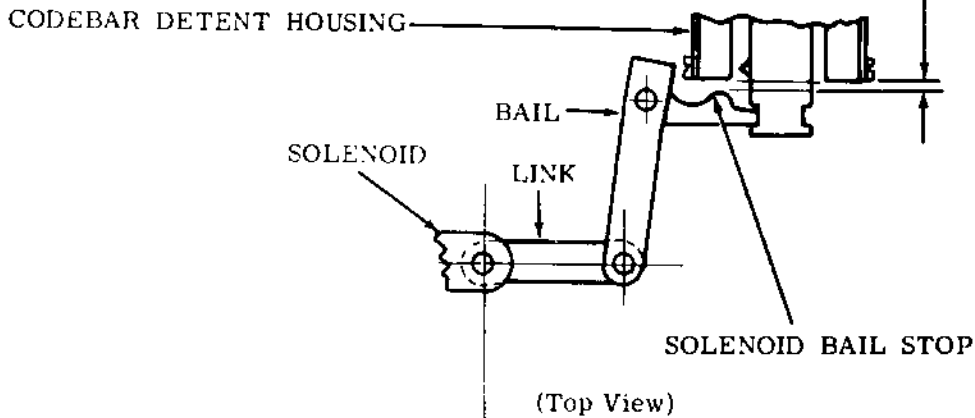

Requirement

With the solenoid in the de-energized condition, unhook the front end of the spring. To pull spring to installed length

Min 2 oz---Max 3 oz

3.32 Lower Solenoid (For Applicable Units)

LOWER SOLENOID

Requirement

With the solenoid in the de-energized condition there should be  
Min 0.030 inch---Max 0.070 inch  
between the clutch suppression arm and the end of the solenoid  
lever.

To Adjust

Loosen the two solenoid adjusting screws and position the  
solenoid to the requirement.

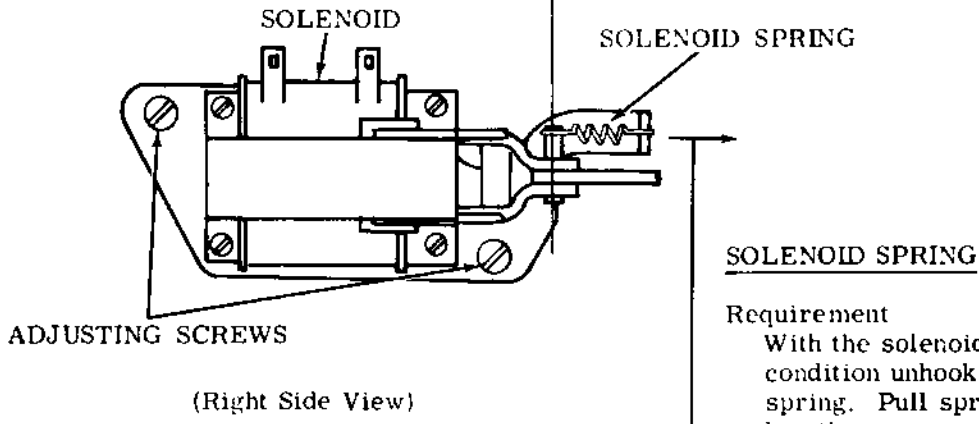
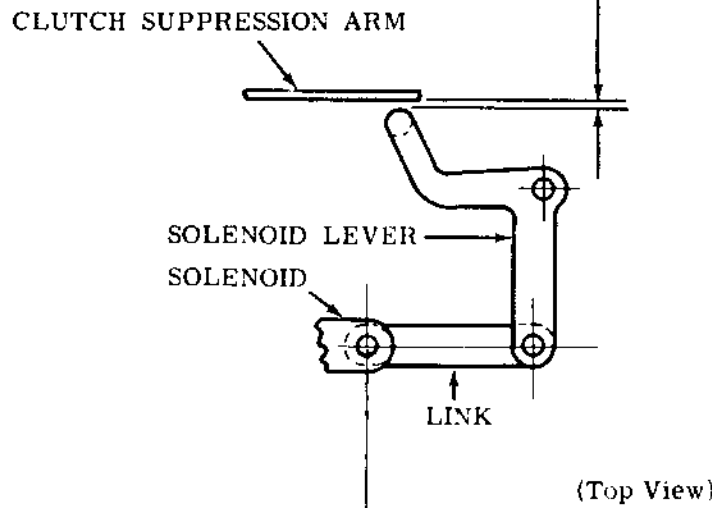

SOLENOID SPRING

Requirement

With the solenoid in the de-energized  
condition unhook the front end of the  
spring. Pull spring to installed  
length.

Min 2 oz---Max 3 oz

To Adjust

Replace the spring.

## 3.33 Print-Nonprint Solenoid Mechanism

(A) SOLENOID PLUNGER

## (1) Requirement

With the solenoid plunger held against the stop inside of the solenoid, the outer edge of the end of the suppression codebar should line up with the outer edge of the end of spacing no. 2 codebar. Also, when the suppression codebar is spacing, the tines of the suppression bar should line up with the tines of the no. 2 codebar. Vertically align either point by eye in both marking and spacing positions.

## To Adjust

Loosen the solenoid mounting screws and move the solenoid forward or backward to meet both of these requirements. Check outer edges of the bars and the tine line-up by eye. Check tines by sighting over and through stunt box at rear of unit. Recheck requirement. Tighten screws.

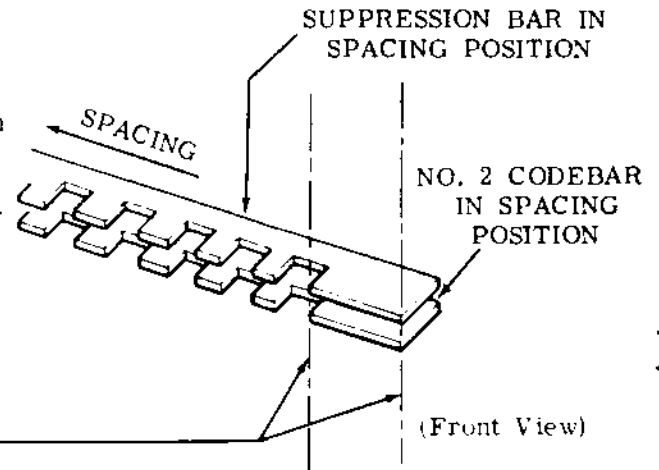

## (2) Requirement

With 48 v dc applied to the solenoid, recheck Requirement (1); the suppression codebar should not overtravel when the solenoid is energized.

## To Adjust

Same as above.

(B) SOLENOID CONTACT

## Requirement

With the solenoid de-energized and the plunger in the unoperated position there should be Min 0.010 inch--Max 0.020 inch gap between the contacts.

Note: Open up the contact cover to measure gap and to facilitate the following adjustments. Close contact cover after the requirements are met.

## To Adjust

Bend the contact springs to gain the requirement.

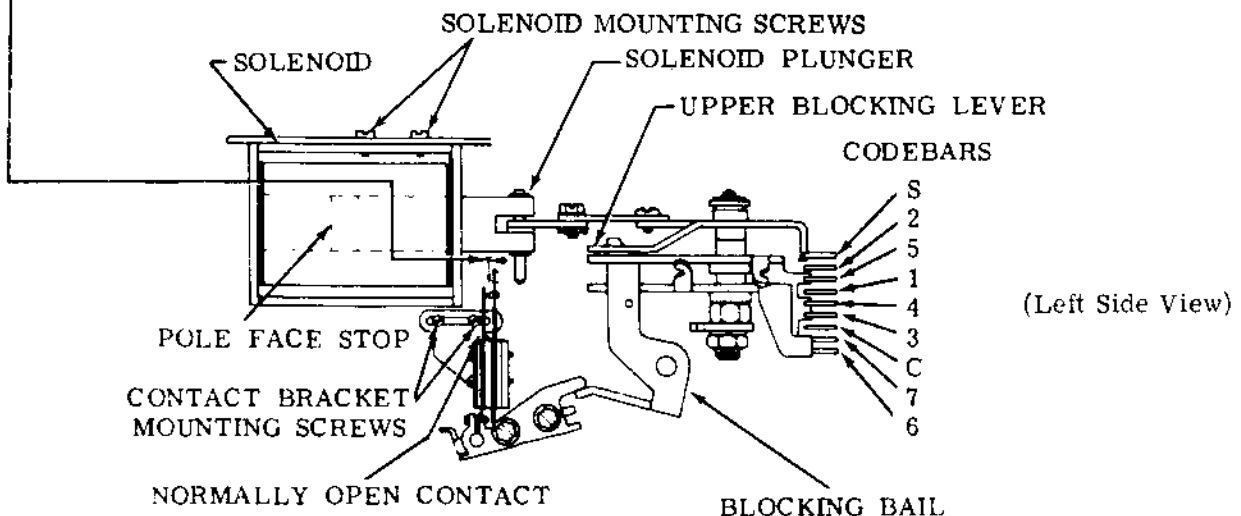

3.34 Print-Nonprint Solenoid Mechanism (continued)

SUPPRESSION BAR RETURN SPRING (FOR UNITS EMPLOYING THE PRINT SUPPRESS SOLENOID MECHANISM)

Requirement

With the solenoid de-energized and suppression bar moved to the left, push against the left end of the bar and parallel to the bar. All bearing points in solenoid linkage must be free of binds.  
Min 2-1/2 oz---Max 4-1/2 oz  
to start the bar moving to the right.

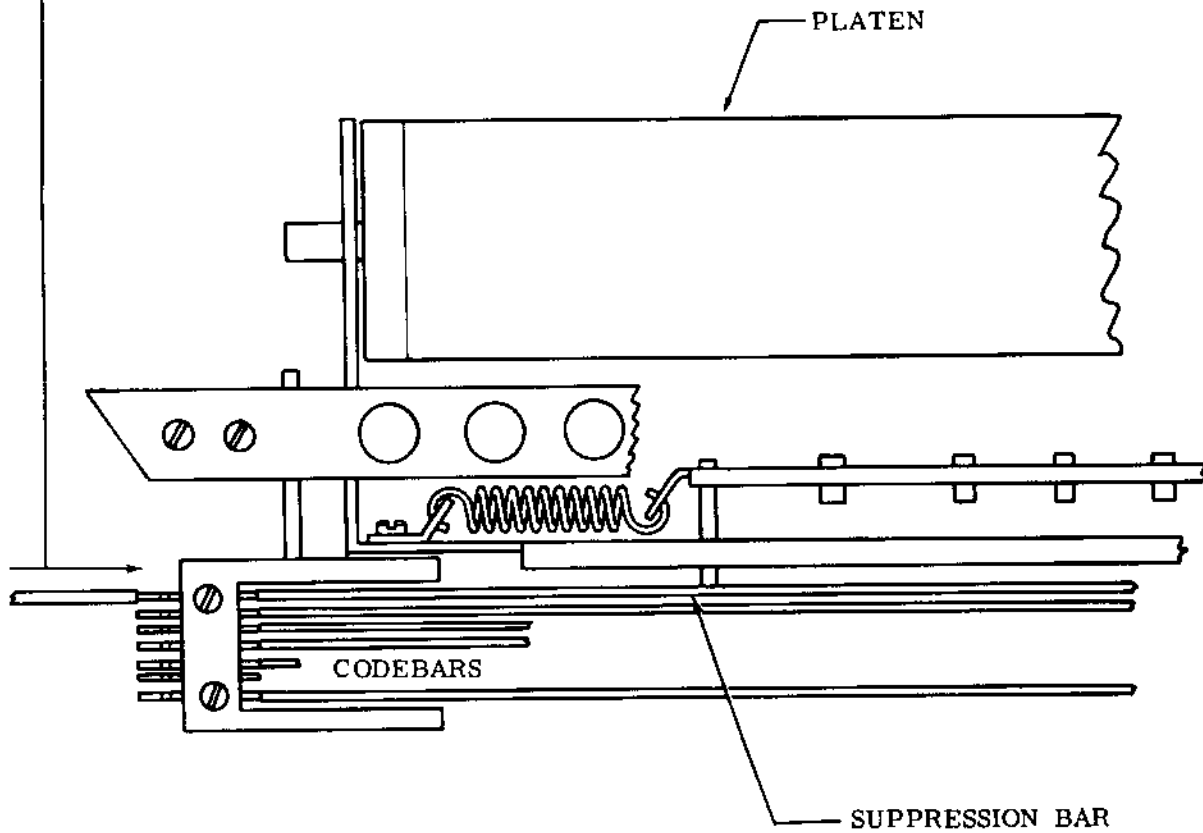

(Front View of Printer)

## 3.35 Print-Nonprint Solenoid Mechanism (continued)

SOLENOID ENERGIZED**Requirement**

With the solenoid plunger held against the solenoid pole face stop, the solenoid pin should operate the contact swinger and close the contacts. It should require a force of at least

Min 2 oz  
to separate the contacts.

**To Adjust**

Loosen the contact bracket mounting screws and position the bracket so that the solenoid pin strikes the contact button just before the end of the plunger travel. Tighten screws. Bend the stationary contact to meet the requirement. Recheck requirement and then close contact cover.

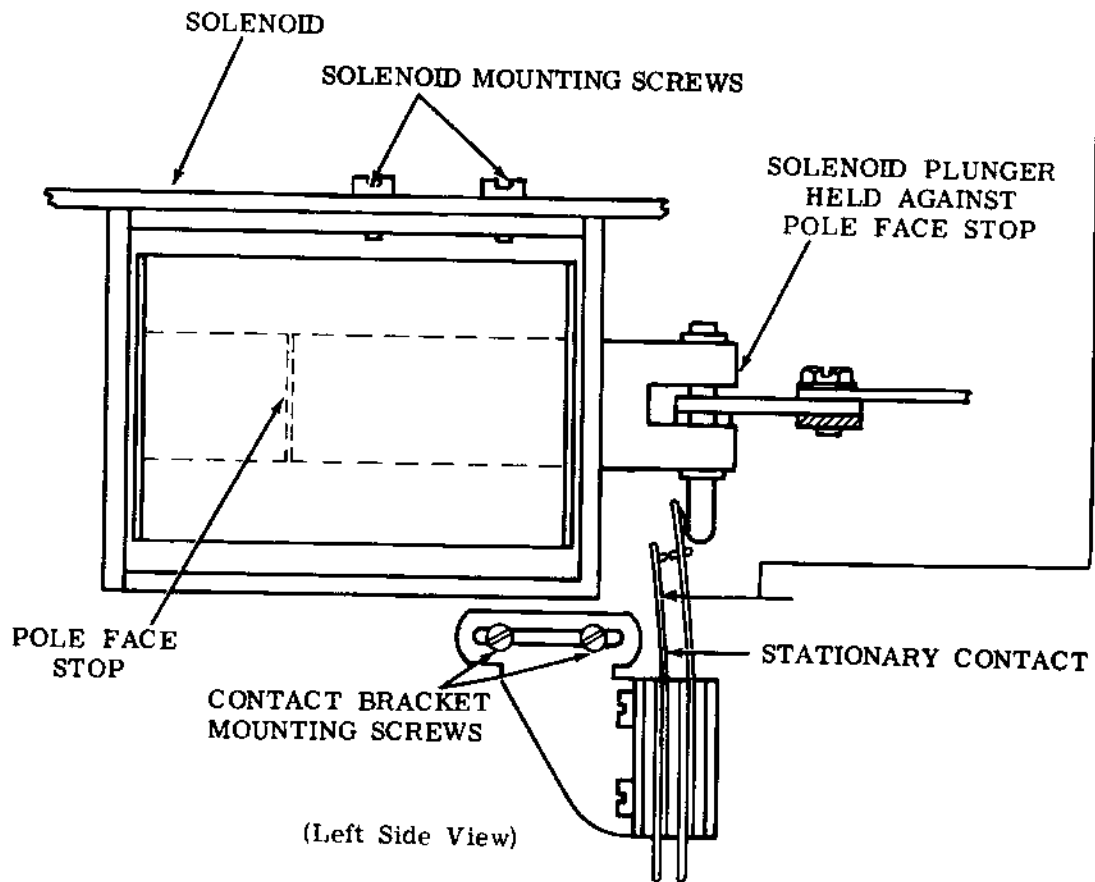

3.36 Print-Nonprint Solenoid Mechanism (continued)

SOLENOID DE-ENERGIZED

Requirement

All pivot points on the solenoid linkage must be free of binds. With the solenoid plunger in its unoperated position, a force of no more than

Max 1-1/4 oz

applied to the end of the plunger should move the plunger when the suppression bar return spring is removed.

To Adjust

Inspect all pivot points for binds.

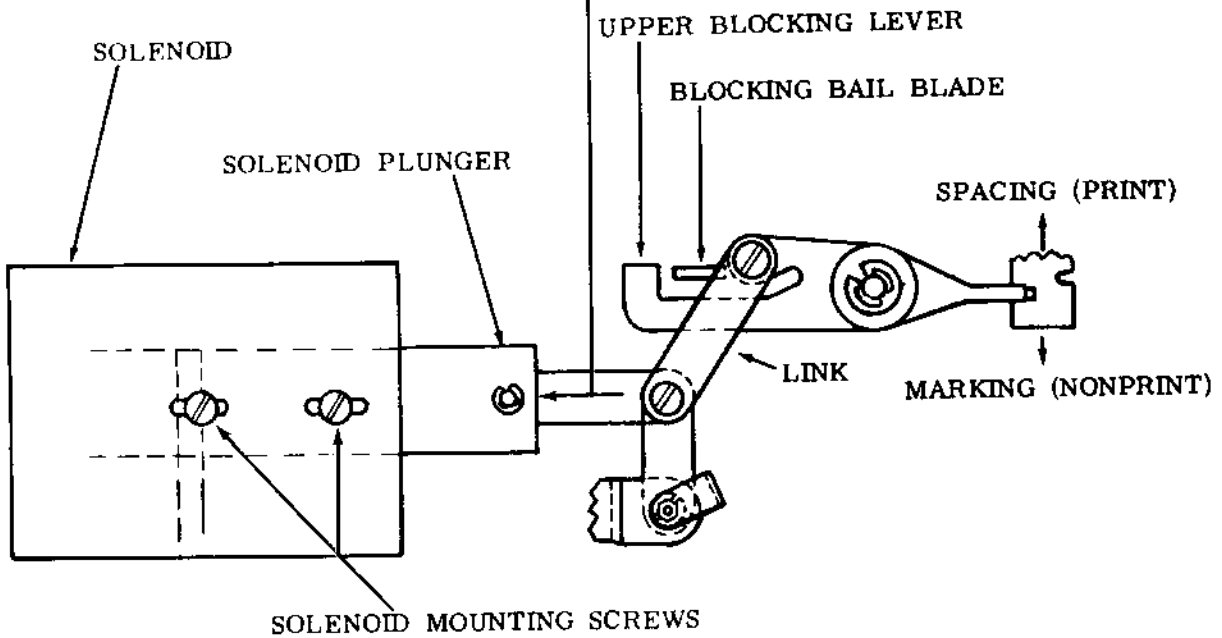

(Top View)

3.37 Print-Nonprint Solenoid Mechanism (continued)

CONTACT BUTTON AND SOLENOID PIN ALIGNMENT

Requirement

The swinger contact button and the solenoid plunger pin should be aligned by eye such that the pin strikes the flat surface of the button.

To Adjust

Loosen the contact pile-up mounting screws and move the contacts left or right to gain the alignment of button and pin. Check to see that the contact points mate fully.

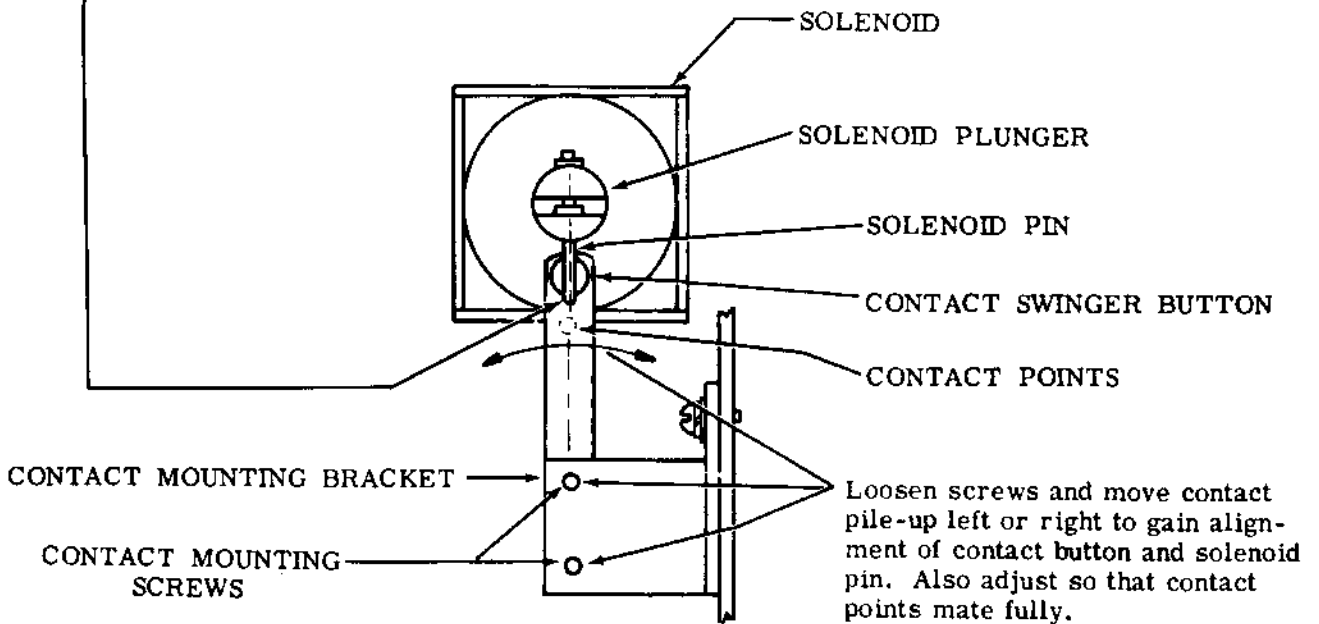

(Front View)



3.38 Timing Contact Mechanism (Operated by Selector)

Note 1: In this text, the letters S, B, and M are used to denote respectively the "swinger", "break" (normally closed with lever riding cam depression) and "make" (normally open; closed only with lever riding cam peak) contact springs.

Note 2: When making adjustments (F) through (H) make certain the "S" spring insulator is clear of the operating lever.

Note 3: Parts should be well aligned and free of sharp bends. Contact points misalignment should not exceed 1/4 the diameter of points.

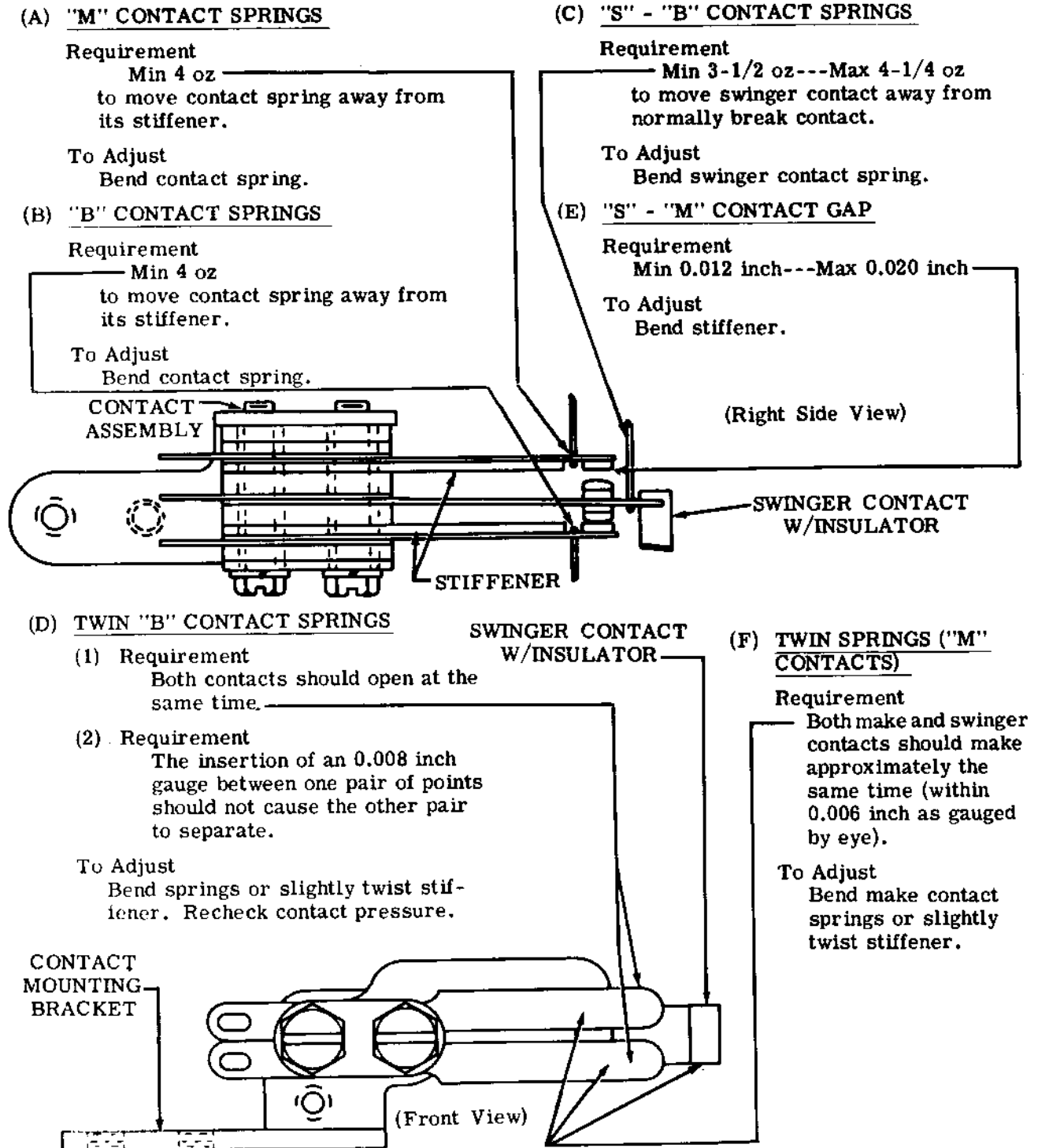

3.39 Timing Contact Mechanism (Operated by Selector) (continued)

(H) CONTACT ASSEMBLY POSITION

(1) Requirement

Set range scale at 50 (important).  
Rotate shaft so operating lever is on lowest part of cam.

To Adjust

With mounting screws loosened position contact assembly by means of its oversize mounting holes so lever can be moved

Min 0.002 inch---Max 0.006 inch before it touches the swinger spring, and so first touch is on lower half of spring stud wearing plate.

(2) Requirement

(At higher settings, movement will be larger: disregard.) Tighten screws and recheck. Rotate shaft and note the high part of cam causes both "M" contacts to move at least

Min 0.012 inch

If this contact movement is not met at setting 60 and 90, check for insecure parts and refine contact gap between swinger and make contact. If still not met, replace range scale sector rack.

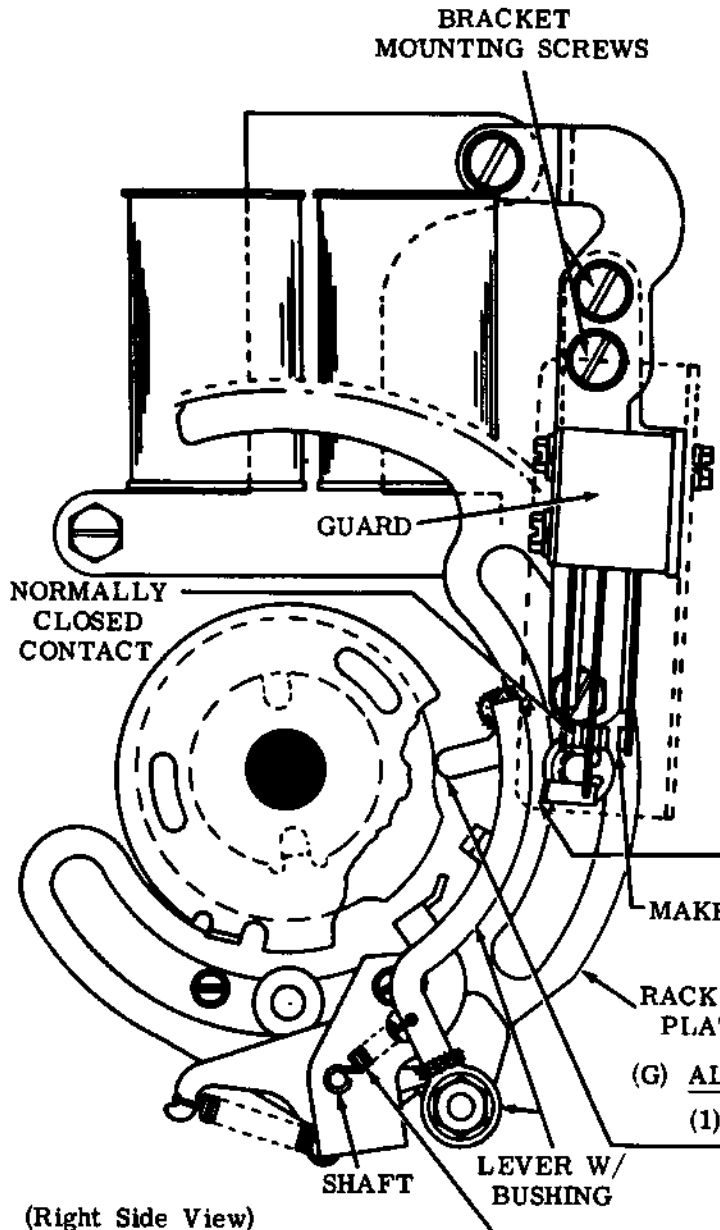

(Right Side View)

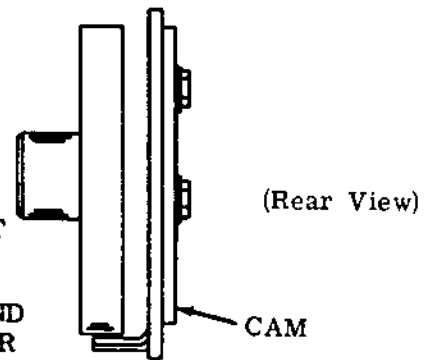

(G) ALIGNMENT OF OPERATING LEVER WITH CAM

(1) Requirement

Operating lever's full thickness should ride cam.

To Check

Take up all cam endplay toward selector to clutch drum, all operating lever endplay (at its bearing) in opposite direction. Observe lever and cam for full engagement.

(2) Requirement

Lever should not exert pressure against face of clutch disc.

To Adjust

Refine clutch drum endplay.

(I) OPERATING LEVER SPRING

Requirement

The spring should hold operating lever against cam with light pressure. With spring removed

Min 2 oz---Max 3 oz  
to stretch spring to 5/8 inch length.

3.40 Timing Contact Mechanism (Operated by Selector) (continued)

(A) TIMING VERIFICATION, 11.00 UNIT CODE

Note 1: DXD means distortion test set.

→ Note 2 : Requirements (1), (2), or (4), may be omitted if the stroboscopic tests of Requirement (3) are to be made.

(1) Requirement

TP174451 Cam: With range scale at 45, manually rotate main shaft with selector armature spacing. The M contacts should close soon after, but not before, the locklever blocks the selector armature after the no. 8 selection. Continue rotation into the next cycle. With the selector armature marking, note that the M contacts again close and that they open and the B contacts close before the selector clutch slips (it may not latch because of the slow rotation).

(2) Requirement

TP174450 Cam: With range scale at 90 and the selector marking, rotate the shaft and latch the clutch. The M contacts should be closed. Trip the clutch and slowly rotate the shaft. The B contacts close after rotation starts. Repeat at range setting 45.

(3) Requirement

Stroboscopic Tests: Connect the B-S or S-M terminals (as required into a 120 v dc viewing circuit of 11.00 unit DXD or similar stroboscopic test set, 600 opm. Connect the DXD test message output or a comparable signal source in a line circuit to the selector magnets. Set distortion at zero. Synchronize the viewing scale with the transmitted signals. Observe DXD stroboscopic display of signals listed below. Ignore rhythmic shifting of a signal. This shifting occurs because of slight rotational displacement of the motor armature (and of the selector cam) as it encounters loads such as line feed, etc, from one printer cycle to the next. The shifting is exhibited as lighter colored display at the beginning or end of a signal. True readings are at the observed midpoints of shifting areas. If any shift area should be excessive, say over 18 DXD divisions total, it may be indication of binds, slippages, or wear in the machine. Signals should be clear of gaps (except see ++ below) (indicate dirt, chatter, or bounce) after the first ten DXD divisions of closure. Where only one range setting is specified, it indicates that tests at that setting are sufficient to verify performance at other settings.

## 3.41 Timing Contact Mechanism (Operated by Selector) (continued)

<u>Test Conditions</u>		<u>Signal Length in Viewed DXD Divisions</u>	
<u>Cam</u>	<u>Contact Pair</u>	<u>Message Stopped, Marking</u>	<u>Message Running</u>
TP174451	S-M	Dark at range 45	Min 104 at range 90. Begins after 11 of beginning of stop pulse, ends before 148 of stop pulse.
	B-S	1100 at range 45	++890-979
TP174450	S-M	1100 at range 45 & 90	++ Min 148 at range 90. Begins in stop pulse, ends before 48 of #1 pulse.
	B-2	Dark at range 45	++845-948
TP323070	B-S		

++ While viewing DXD, slowly move range scale from 90 to 45. If, at some setting there is within the signal a gap, it should not exceed 8 DXD divisions.

## (4) Requirement

TP323070 Cam: With range scale set at 50 and the clutch latched, the normally closed contact should be closed. Trip the clutch and manually rotate the main shaft. The contact should open after the locklever is in place for the number one selection and close before the locklever is in place for the number five selection.

(B) CORRECTION OF TIMING

Check for the following:

- (1) Wrong cam
- (2) Range scale knob maladjusted
- (3) Contact, lever, and bracket adjustments. Refine if required.
- (4) Parts loose
- (5) Contacts dirty
- (6) Improper test connections
- (7) Improper synchronism of sending and stroboscopic portions of test set. Note that test message is to be sent direct to selector magnets. Introduction of a line relay, contact protection network, or any other condition affecting magnet release time will displace the viewed signals produced by the modification kits.

3.42 Two Color Ribbon Mechanism

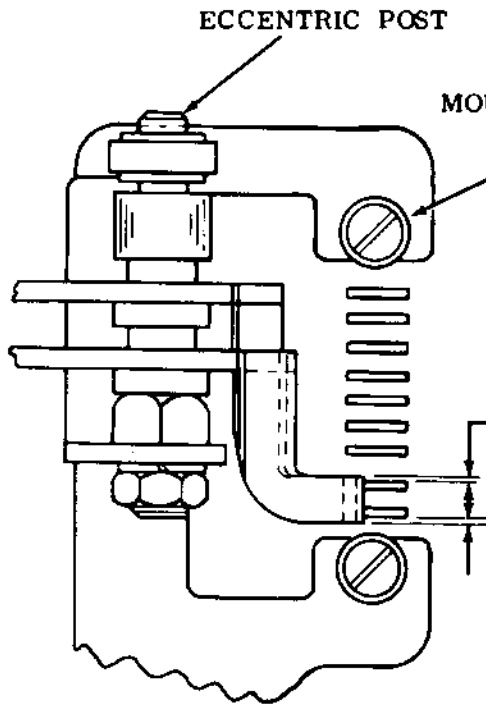

(Left Side View)

RIBBON LEVERS

**Requirement**

Lever extensions fully engaged by codebars no. 6 and 7, as gauged by eye.

**To Adjust**

Position contact assembly with mounting screws friction tight.

CONTACT ACTIVATING LEVER

**Requirement**

With codebars no. 6 and 7 in same condition (marking or spacing), the clearance between the contact swinger pad and its respective lever should be

Min 0.010 inch

**To Adjust**

Position eccentric post; keep high part of eccentric toward left of unit.

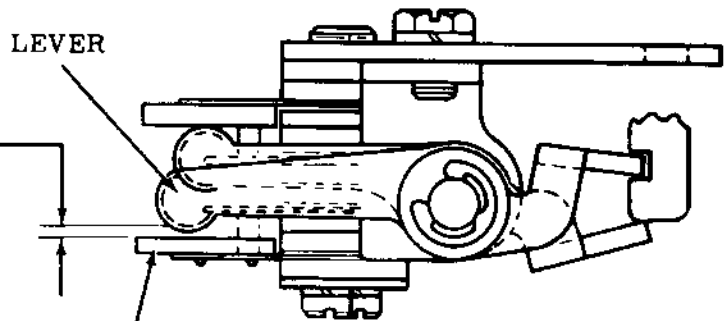

(Top View)

CONTACT SWINGER PAD

3.43 Two Color Ribbon Mechanism (continued)

CONTACT SPRING

Requirement

To separate the normally closed contacts, it should require

Min 1-1/2 oz---Max 2-1/2 oz

To Adjust

Bend stationary contact spring.

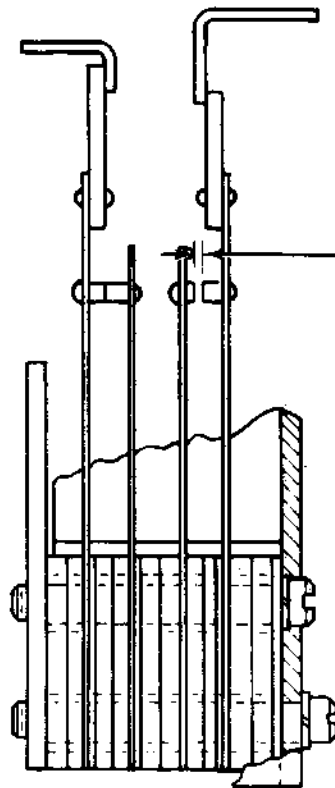

CONTACT GAP

Requirement

With no. 6 and 7 codebars in opposite conditions (one marking and one spacing), there should be a gap between the contact points

Min 0.020 inch

To Adjust

Refine CONTACT ACTIVATING LEVER (3.42).

(Top View)

3.44 Paper Jam Alarm (Sprocket Feed)

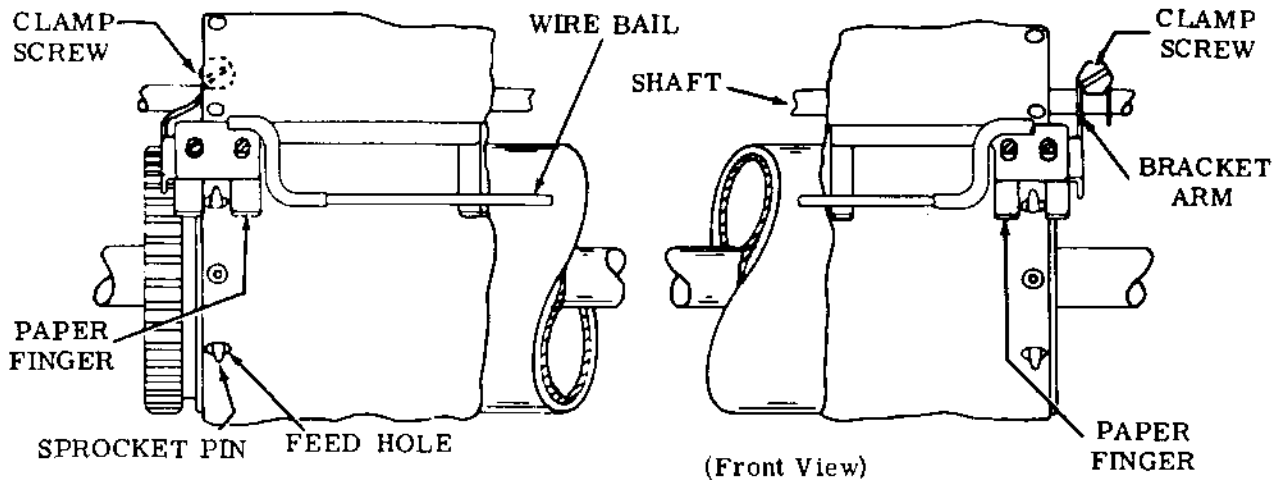

Note: Before proceeding with WIRE BAIL adjustment, loosen switch plate mounting screws and rotate switch and latch to a position where they do not interfere with bail. Position the spring post by means of set collar so that spring has some initial tension. Spring post should be approximately 30° from vertical (see drawing, 3.46).

WIRE BAIL

Requirement

Wire bail should rest on paper fingers approximately in radius of fingers. Wire bail should touch at least one finger with not more than  
 —Max 0.015 inch  
 clearance between other finger and wire bail.

To Adjust

Bend wire bail to meet requirement.

Note: Make sure there is no bind in the bail after making adjustment.

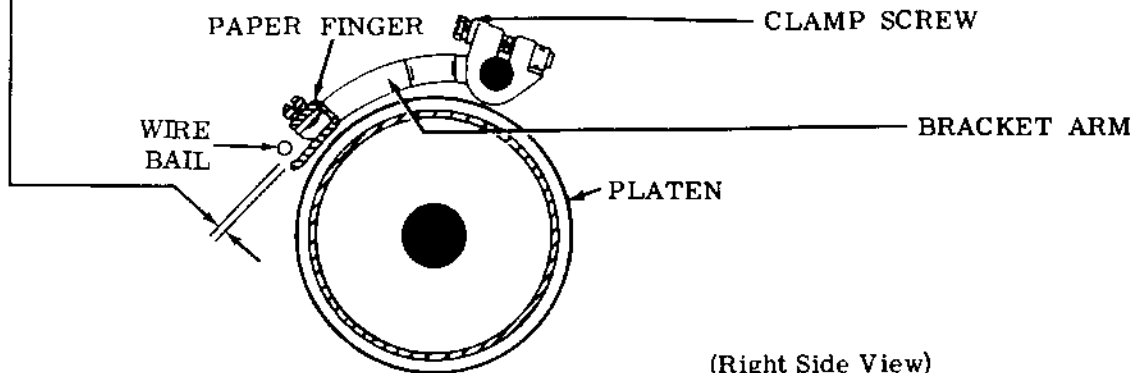

## 3.45 Paper Jam Alarm (Sprocket Feed) (continued)

SWITCH POSITION**Requirement**

With wire bail held against paper fingers and operating lever latched behind operating bail, there should be

Min 0.035 inch---Max 0.065 inch  
between top of bail and bottom of step in lever. Lever should depress switch plungers sufficiently to operate switches.

**To Adjust**

Loosen screws and position switch plate. Tighten screws.

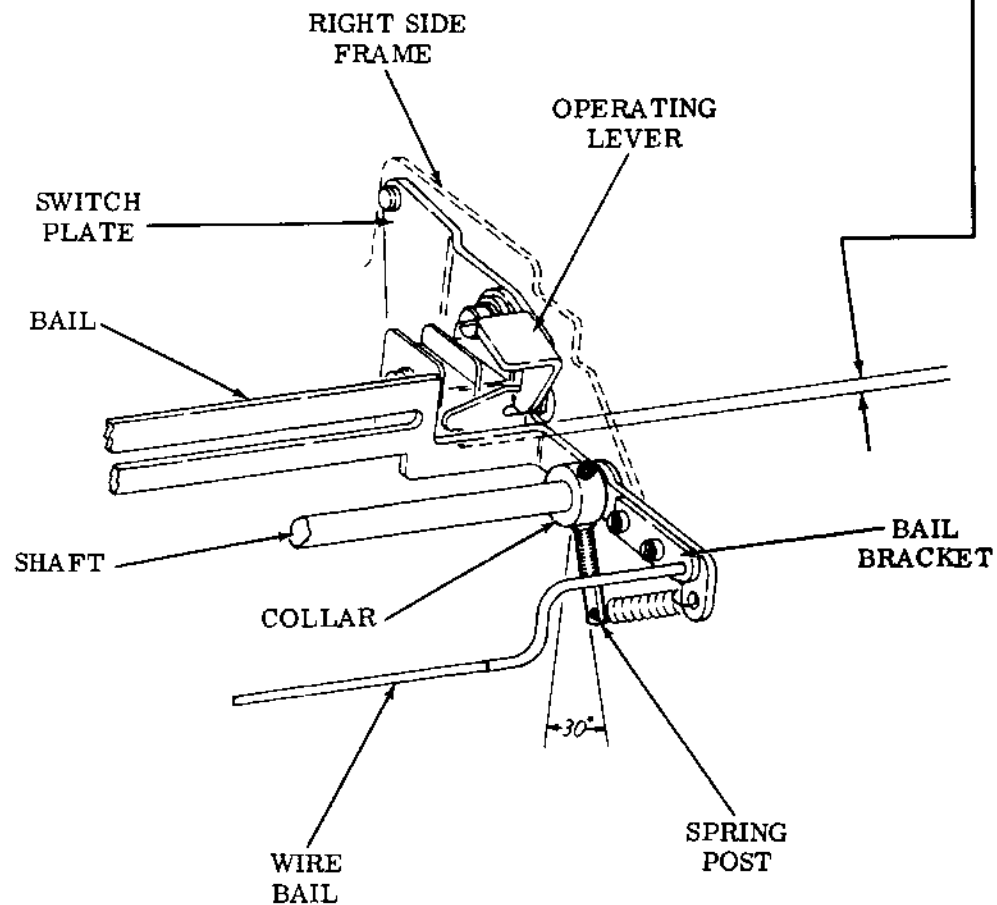

(Right Front View)



3.46 Paper Jam Alarm (Sprocket Feed) (continued)

(Right Front View)

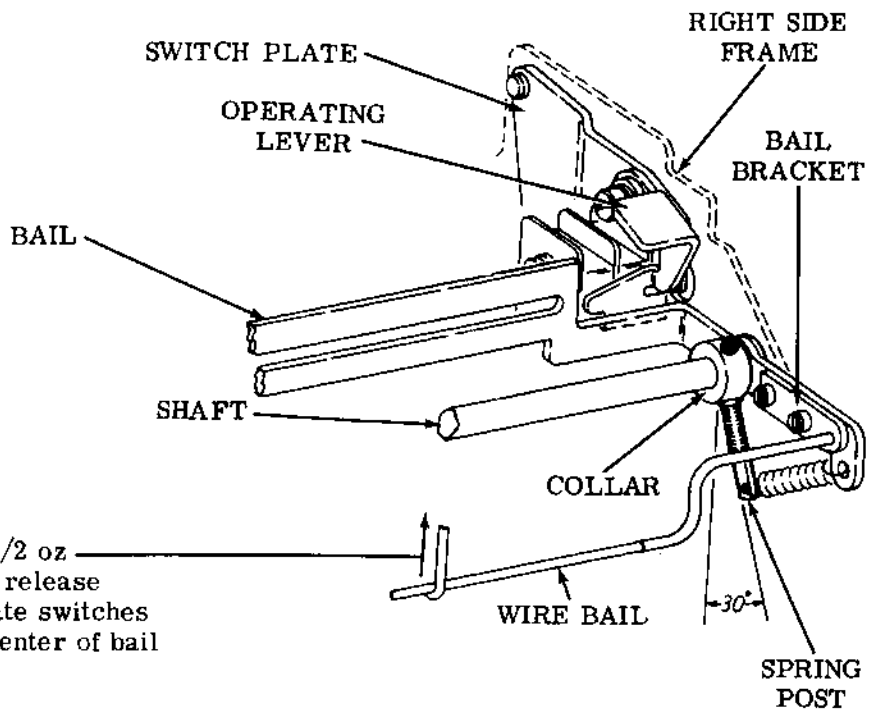

BAIL SPRING

(1) Requirement

It should require

Min 1/2 oz---Max 1-1/2 oz  
to lift bail high enough to release  
operating lever and operate switches  
when scale is hooked to center of bail  
and pulled vertically.

(2) Requirement

Position collar laterally to provide  
Min some---Max 0.006  
endplay for bail.

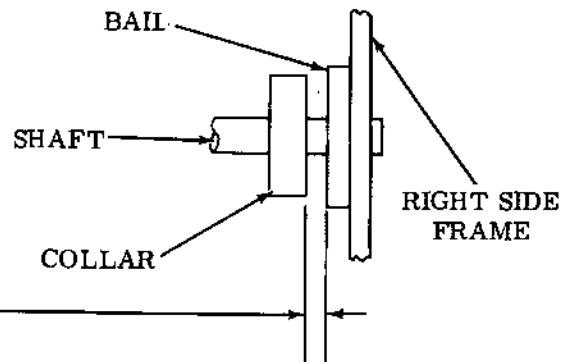

To Adjust

Loosen setscrew. Position collar to meet  
requirements. Tighten setscrew.

(Right Front View)

Note 1: With play of bail taken to right, left side of bail should clear left paper finger arm. Refine left PAPER FINGER (SPROCKET FEED) (2.79) adjustment if necessary.

Note 2: With typing unit installed in its cabinet, lift bail to its maximum upward position, there should be some clearance between bail and operating lever.

Note 3: BAIL SPRING adjustments may be refined to make mechanism more or less sensitive to paper buckling.

3.47 Universal Function Bar

CODING

CODING FOR 8-LEVEL FUNCTION BARS

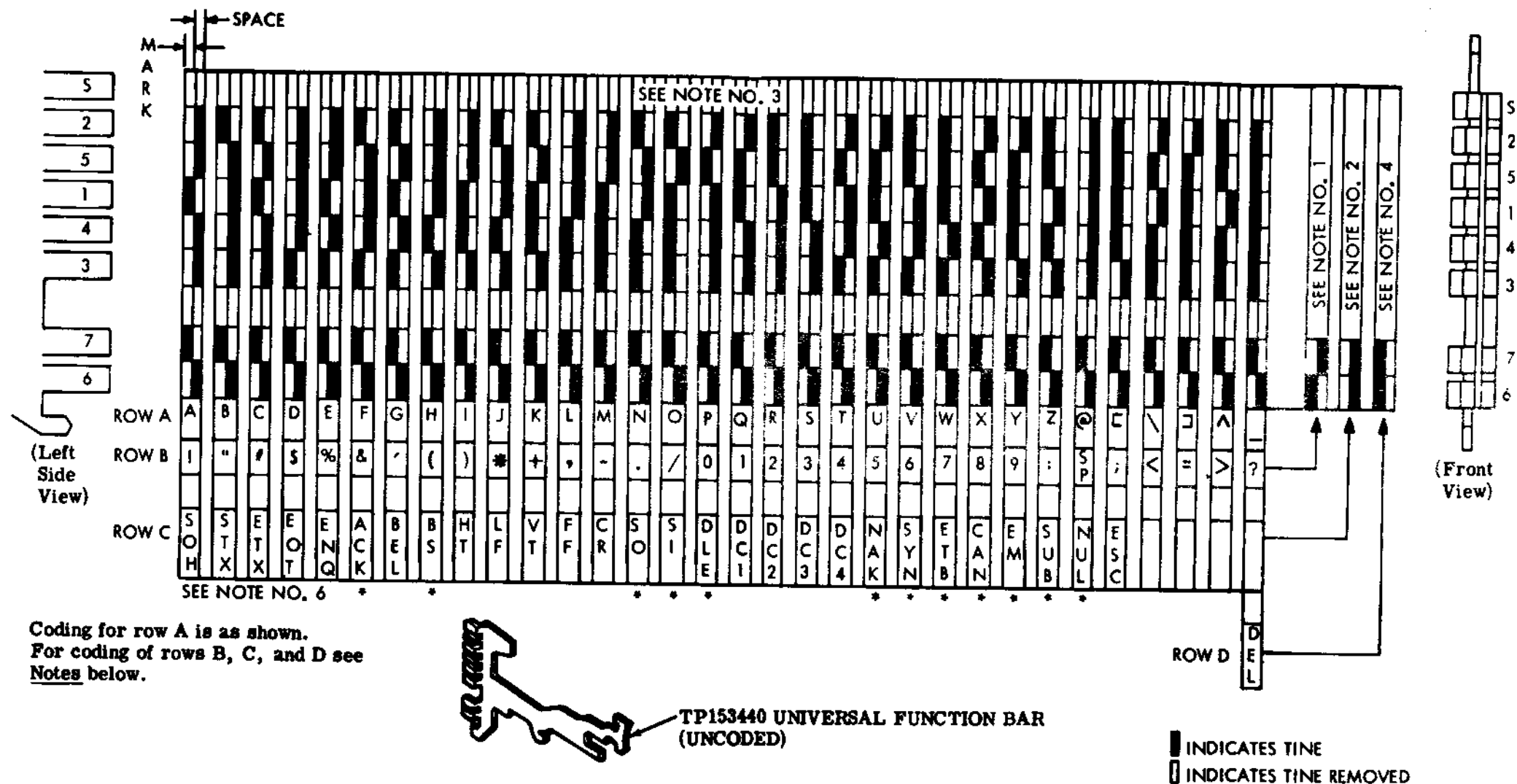

Coding for row A is as shown.  
For coding of rows B, C, and D see Notes below.

Notes:

1. To operate function bars on symbols and numbers in row B, number 6 tine is left on the marking side and, number 7 tine is left on the spacing side.
2. To operate function bars on nonprinting functions in row C, number 6 and number 7 tines are left on the spacing side.
3. Suppression tine can be coded marking, spacing, or both to control the function bar. In selective calling systems and systems using the stunt shift solenoid, code as follows:
  - a. To sense suppression bar in mark (nonselect or nonprint), break off the spacing tine.
  - b. To sense suppression bar in space (solenoid operated, select or print), break off the marking tine.
  - c. To sense in either condition break off both tines.
  - d. In TWX and other systems not using a stunt shift solenoid, the suppression codebar is held by a clip in the spacing position. Break off marking tine.

4. To operate function bar on code in row D, number 6 and number 7 tines are left on the marking side.
5. The number 8 codebar is omitted from the printer since the number 8 code bit is not used for printing.
- \*6. These characters in row C have no associated keytop on Model 35 keyboards.
7. Bell system uses the 1966 ASCII code as shown on the above illustration except for the following:

ASCII CODE	BELL SYSTEM USAGE	ASCII CODE	BELL SYSTEM USAGE
ENQ	WRU	DC1	XON
BEL	BELL	DC2	TAPE
HT	TAB	DC3	XOFF
LF	LINE FEED	DC4	TAPE
CR	RETURN	DEL	RUB OUT

8. Refer to appropriate parts section for additional cross reference information pertaining to function bars and codes.

35 KEYBOARD AND BASE FOR KEYBOARD SEND-RECEIVE AND RECEIVE-ONLY SETS

ADJUSTMENTS

CONTENTS	PAGE	CONTENTS	PAGE
1. GENERAL . . . . .	2	No. 5, 8 inversion codebar springs . . . . .	9 ←
2. BASIC UNITS . . . . .	4	Nonrepeat lever spring tension . . . . .	13
Keyboard		Shift lockbar spring . . . . .	9 ←
Ball wedge lock, ball endplay and universal bail latch (final) . . . . .	14	Signal contact clearance . . . . .	8
Ball wedge lock and ball track clearance (preliminary) . . . . .	14	Signal contact drive link . . . . .	8
Clutch latchlever spring tension . . . . .	6	Signal contact spring . . . . .	8
Clutch shoe lever . . . . .	5	Signal generator frame . . . . .	22
Clutch shoe lever spring tension . . . . .	7	Signaling code contact (strobing) . . . . .	19
Clutch stop lever . . . . .	7	Spacebar bail pivot . . . . .	4
Clutch stop lever spring tension . . . . .	6	Timing belt . . . . .	24
Clutch tripbar spring tension . . . . .	9	Transfer bail detent latch spring . . . . .	8
Codebar and code lever clearance . . . . .	9	Transfer bail detent plate . . . . .	8
Codebar bail spring tension . . . . .	12	Transfer lever locking bail spring . . . . .	21
Codebar guide clearance . . . . .	4	Transfer lever spring . . . . .	21
Codebar reset bail . . . . .	11	Universal bail extension . . . . .	15
Codebar reset bail and nonrepeat lever . . . . .	13	Universal bail latchlever (preliminary) . . . . .	15
Codebar reset bail latch spring . . . . .	11	Universal bail latch spring . . . . .	15
Codebar springs (no. 1, 2, 3, 4, 5, 6, 7 and 8) . . . . .	9 ←	Universal bail — rear blade . . . . .	15
Code lever spring tension . . . . .	20	Wall mounted intermediate gear assembly . . . . .	24
Code lever universal bail spring . . . . .	4	RO Base	
Control lockbar spring . . . . .	9 ←	Local carriage return bail spring . . . . .	25
Function bail levers and code lever clearance . . . . .	10	Local line feed spring . . . . .	26
Intermediate gear assembly . . . . .	23	3. VARIABLE FEATURES . . . . .	27
Inversion bar latching bail spring . . . . .	17	Answer-back main shaft gear . . . . .	27
Inversion codebar latch (earlier design) . . . . .	16	Backspace transfer bail adjusting lever . . . . .	42
Inversion codebar latch (later design) . . . . .	17	Backspace transfer bail spring . . . . .	42
Inversion latch spring tension . . . . .	16	Backspace trip link horizontal spring . . . . .	42
Keytop guide spacing . . . . .	12	Backspace trip link vertical spring . . . . .	42
Local carriage return function bail spring tension . . . . .	20	Keyboard universal contact . . . . .	43
Local line feed trip link spring . . . . .	16	Local reverse line feed trip link horizontal spring . . . . .	48
Lock ball channel . . . . .	10	Local reverse line feed trip link vertical spring . . . . .	48
Lock ball endplay (preliminary) . . . . .	14	Local single line feed trip link horizontal front spring . . . . .	45
Margin indicator spring . . . . .	21	Local single line feed trip link horizontal rear spring . . . . .	45
Mounting typing unit on keyboard or base . . . . .	22	Local single line feed trip link vertical spring . . . . .	45
		No. 5, 8 inversion code bar springs . . . . .	44

CONTENTS	PAGE
Receive-break switch . . . . .	43
Receive-break switch tension . . . . .	43
Timing cam follower spring (earlier design) . . . . .	29
Timing cam follower spring (later design) . . . . .	31
Timing contact (earlier design) . . . . .	28
Timing contact (later design) . . . . .	30
Timing contact stiffener spring . . . . .	29
Timing contact (strobing) . . . . .	33
Timing contact swinger spring (earlier design) . . . . .	29
Timing contact swinger spring (later design) . . . . .	32
Transition bar spring . . . . .	44
 Auxiliary Contact Mechanism	
Auxiliary contact refinement (strobing) . . . . .	40
Cam follower spring . . . . .	34
Contact gap . . . . .	34
Contact stiffener spring . . . . .	34
Contact swinger spring . . . . .	34
 Code Reading Contact Mechanism	
Adjusting code reading contacts . . . . .	36
Backstop - normally closed contact . . . . .	35
Code reading contact refinement (strobing) . . . . .	39

CONTENTS	PAGE
Code reading contact trace . . . . .	40
Contact swinger spring . . . . .	35
Drive arm extension spring . . . . .	38
Intermediate lever spring . . . . .	37
Latchlever spring . . . . .	37
Marking contact gap . . . . .	37
Normally closed contact spring . . . . .	35
Normally open contact gap . . . . .	35
Reset bail . . . . .	38
Reset bail spring . . . . .	38

Strobing Requirements

Code reading and timing contacts . . . . .	41
Signal generator contacts . . . . .	41

Universal Keyboard Switch Mechanism

Keyboard switch (horizontal) . . . . .	46
Keylever switch (vertical) . . . . .	47

1. GENERAL

1.01 This section covers adjustments for the 35 keyboard and base for keyboard send-receive and receive-only sets. It is reissued to incorporate recent engineering changes. Arrows in the margins indicate changes and additions.



Figure 1 - 35 Keyboard for Send-Receive Sets with Answer-Back

1.02 The adjustments of each unit are arranged in a sequence that would be followed if a complete readjustment of the unit were undertaken. Tools and spring scales required to perform the adjustments are listed in Section 570-005-800TC. After an adjustment has been completed, be sure to tighten any nuts or screws that may have been loosened. The adjusting illustrations, in addition to indicating the adjusting tolerances, positions of moving parts, and spring tension, also show the angle at which the scale should be applied when measuring spring tensions. If a part that is mounted on shims is to be removed, the number of shims used at each of its mounting screws should be noted so that the same shim pile-up can be replaced when the part is remounted.

1.03 When the requirement calls for a clutch to be disengaged, the clutch shoe lever must be fully latched between its trip lever and latchlever so that the clutch shoes release their tension on the clutch drum. When engaged, the clutch shoe lever is unlatched and the clutch shoes are wedged firmly against the clutch drum.

Note 1: After a few weeks (300 to 500 hours) of operation of a new unit, the unit should be relubricated to make sure all operating points have been properly lubricated.

Note 2: Recheck all clutch gaps to insure that the parts, after seating themselves, have not caused the clutch gaps to open up. Reset if necessary. Standard readjustment periods are to be maintained thereafter.

1.04 References made to left or right, up or down, front or rear, etc apply to the unit in its normal operating position as viewed from the operator's position in front of the unit.

1.05 The spring tensions given in this section are indicated values and should be checked with proper spring scales in the position indicated.

1.06 When cleaning plastic parts, use soap or detergent and water. Do not use solvents containing alcohol or chlorinated components.

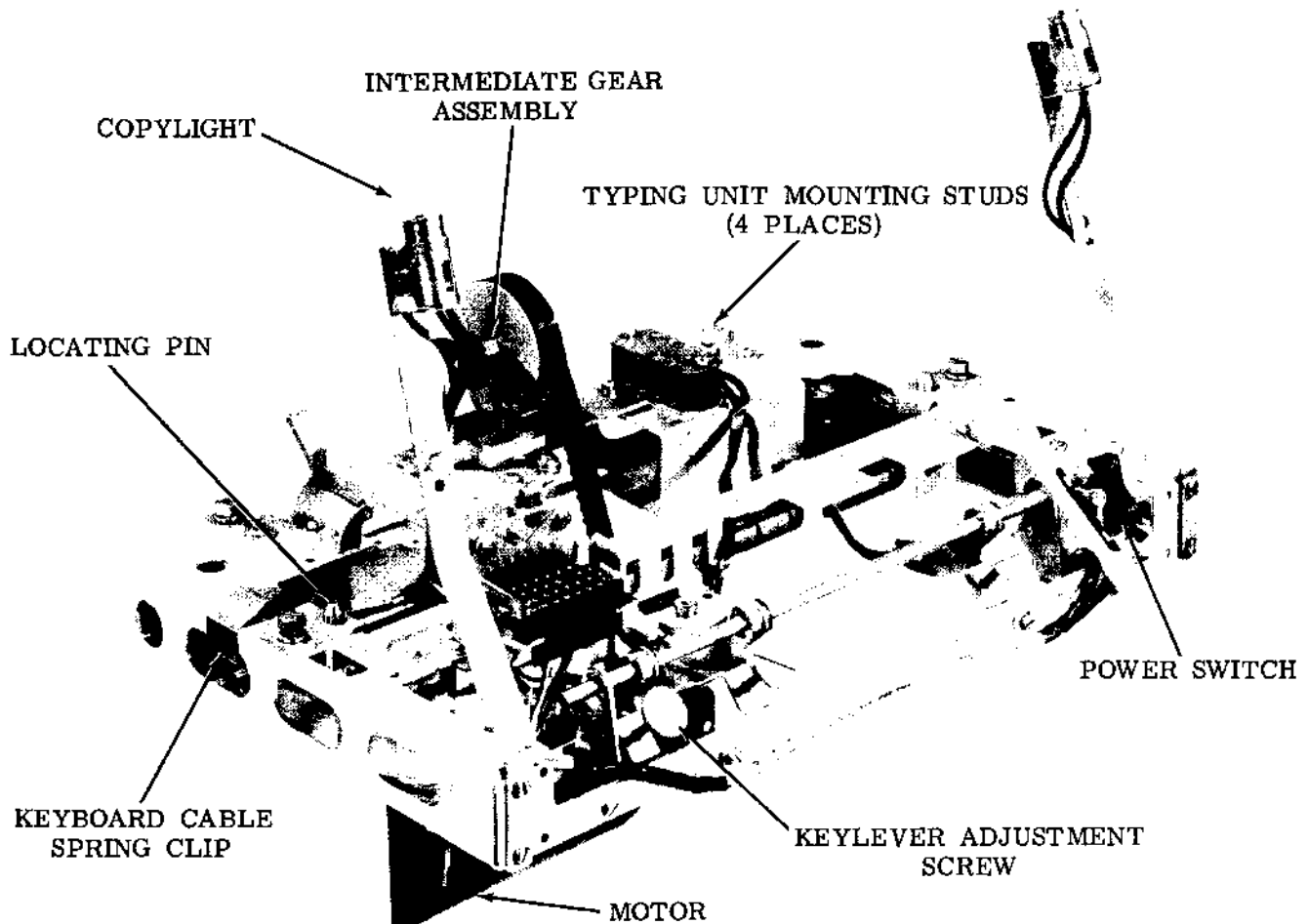

Figure 2 - Wall Mounted Printer Base

2. BASIC UNITS

Keyboard

2.01 Codebar and Spacebar Mechanisms

(B) CODE LEVER UNIVERSAL BAIL SPRING

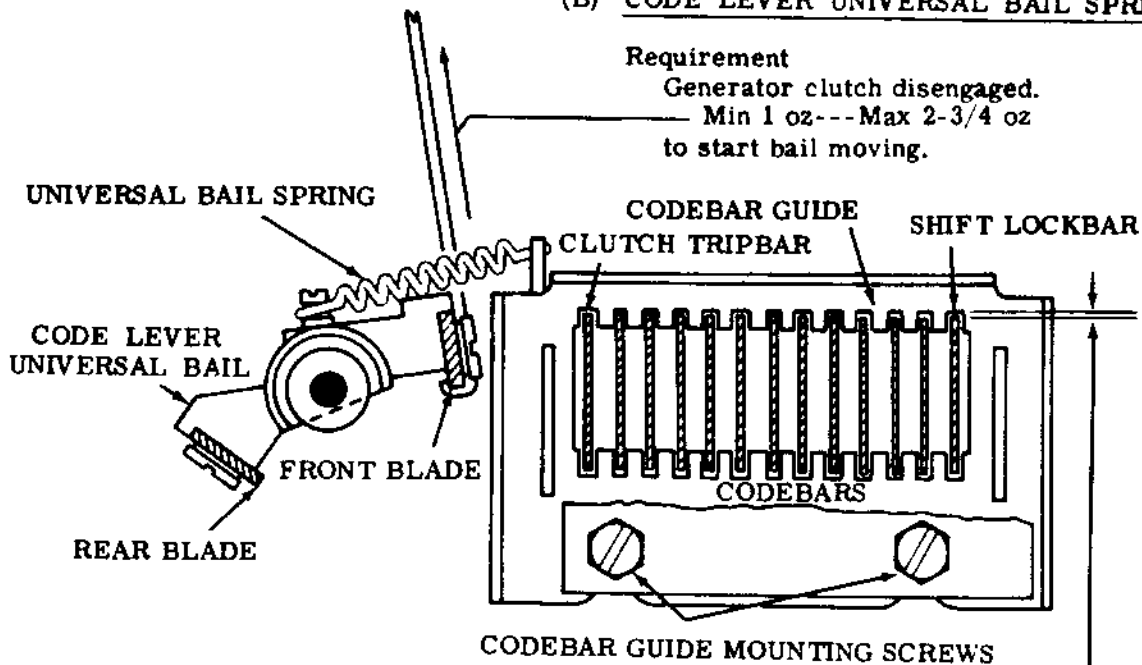

(A) CODEBAR GUIDE CLEARANCE

Requirement

Clearance between the top of no. 1 and no. 8 codebars should be  
Min some---Max 0.006 inch  
All codebars should move freely.

To Adjust

With mounting screws for either the left or right codebar guides friction tight, position guides. Tighten screws.

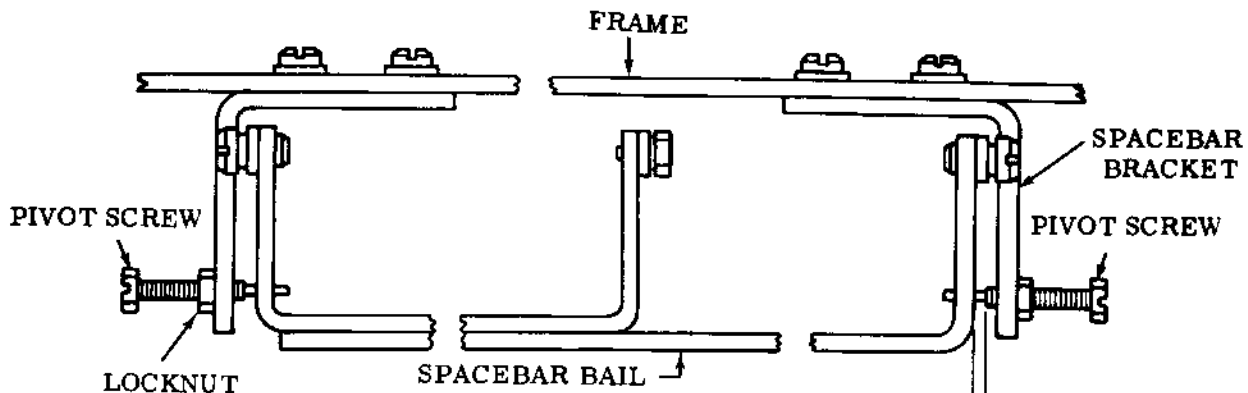

(C) SPACEBAR BAIL PIVOT

Requirement

Min some---Max 0.010 inch  
Spacebar free from bind.

To Adjust

Position spacebar with pivot screws.

## 2.02 Signal Generator Clutch and Gear Mechanism

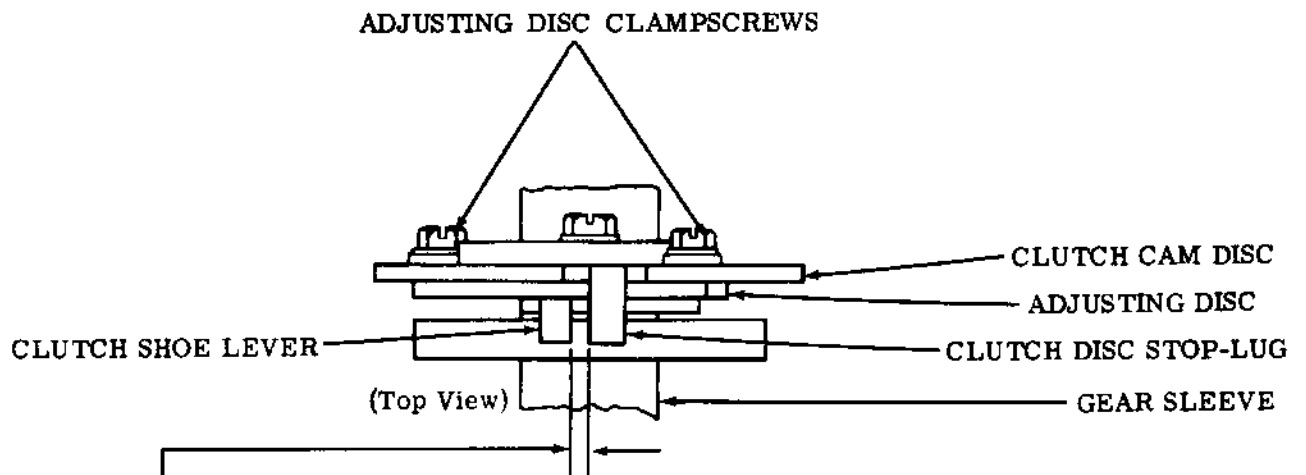
CLUTCH SHOE LEVER**Requirement**

Clearance when clutch is disengaged should be  
 Min 0.055 inch--Max 0.085 inch  
 less than when clutch is engaged.

**To Check**

Latch clutch in disengaged position and measure  
 clearance. Rotate gear until oil hole is upward.  
 Engage clutch and measure clearance.

**To Adjust**

Loosen the two adjusting disc clampscrews to  
 position disc.

2.03 Signal Generator Clutch Mechanism

(B) CLUTCH STOP LEVER SPRING TENSION

Requirement

Clutch engaged and rotated 1/4 turn  
Min 2 oz---Max 3 oz  
to start lever moving.

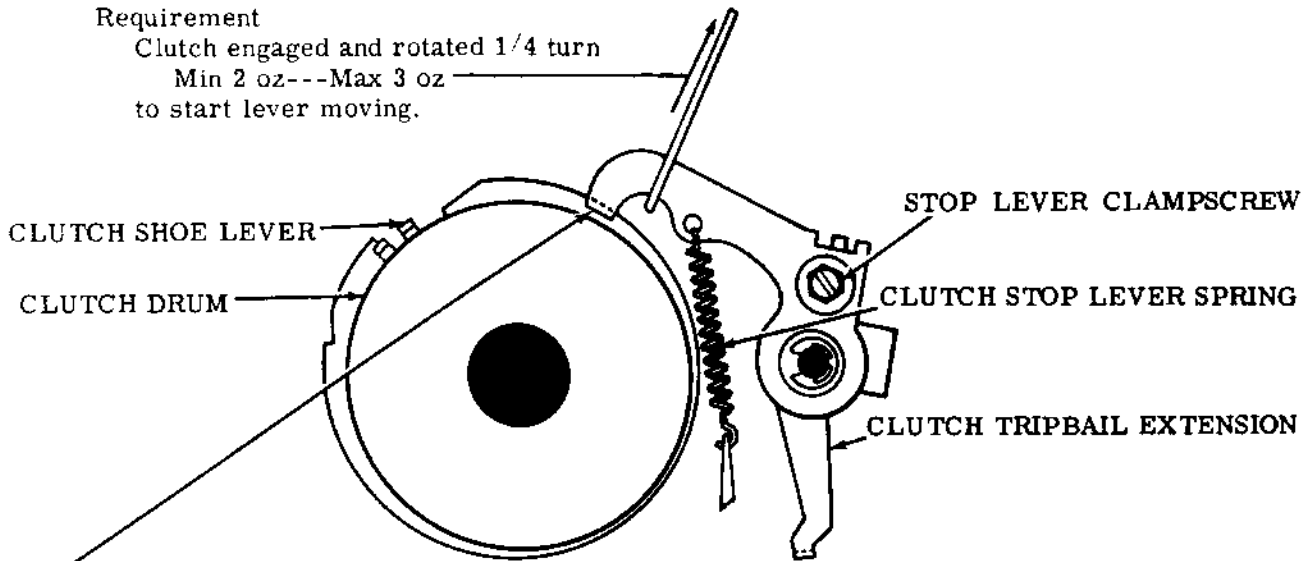

(A) CLUTCH STOP LEVER

Requirement

Should fully engage clutch shoe lever.  
During rotation, the lever should not touch the clutch drum at any point.

To Adjust

Position stop lever with its clamp-screw loosened.

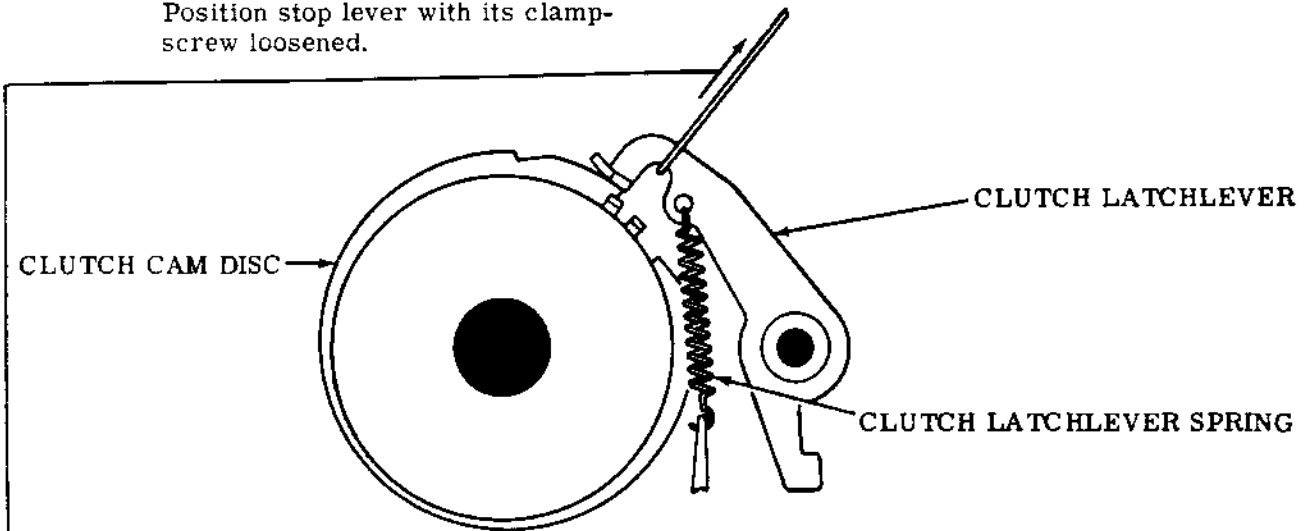

(C) CLUTCH LATCHLEVER SPRING TENSION

Requirement

Clutch latchlever resting on the highest point of clutch disc.  
Min 2 oz---Max 3 oz  
to start latchlever moving.



2.04 Signal Generator Clutch Mechanism (continued)

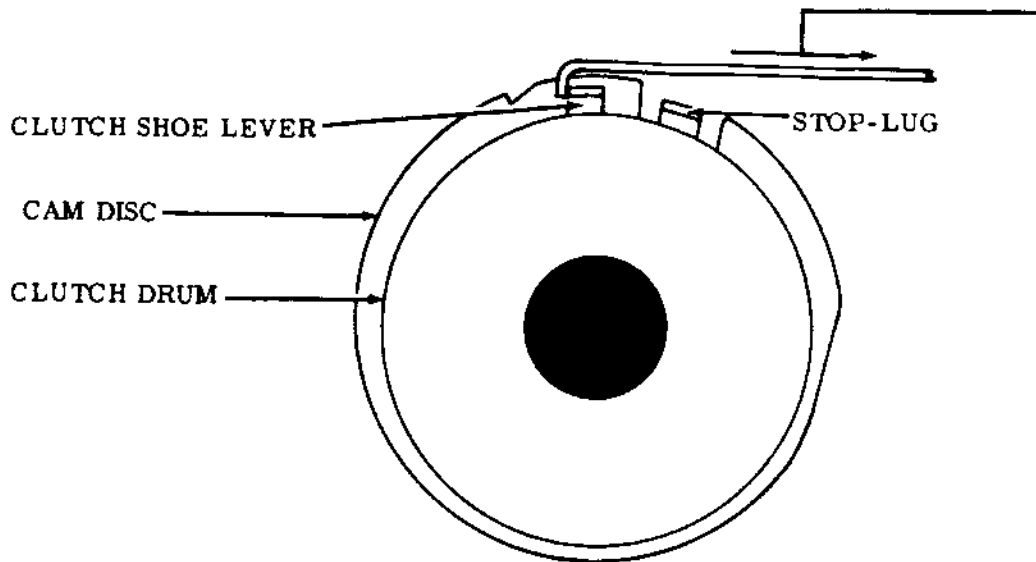

CLUTCH SHOE LEVER SPRING TENSION

**Requirement**

Clutch engaged.

Cam disc held to prevent turning

Min 15 oz---Max 20 oz

to move shoe lever in contact with stop-lug.

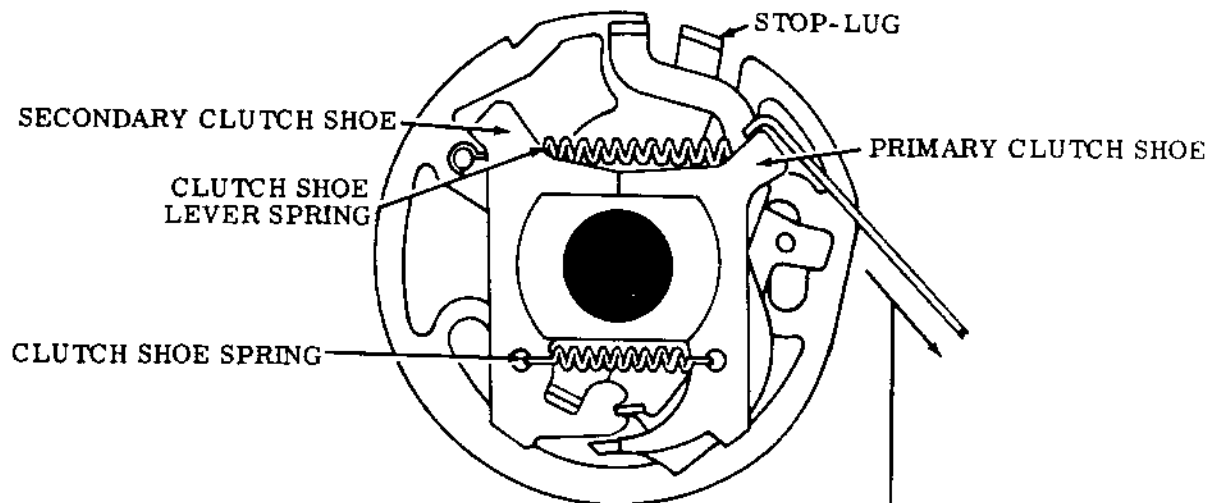

CLUTCH SHOE SPRING TENSION

**Note:** In order to check this spring tension, it is necessary to remove the clutch from the main signal generator drive shaft. Therefore, it should not be checked unless there is good reason to believe that it does not meet its requirement.

**Requirement**

Clutch drum removed.

Min 3 oz---Max 5 oz

to start primary shoe moving away from secondary shoe at point of contact.

2.05 Transfer Bail and Contact Box Mechanism

TRANSFER BAIL DETENT LATCH SPRING

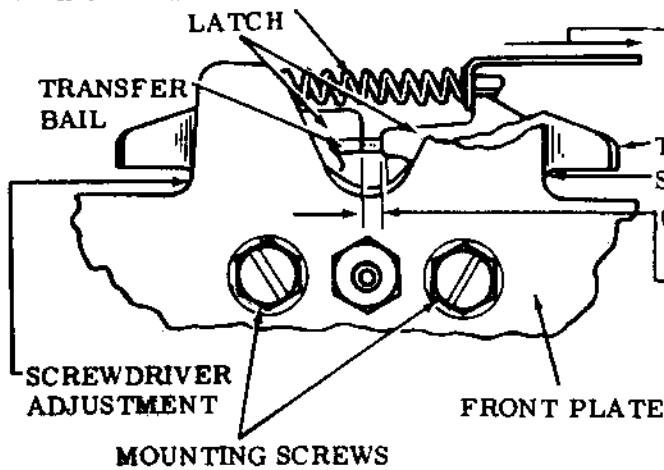

(B) TRANSFER BAIL DETENT LATCH SPRING

Requirement  
 Min 2-3 1/4 oz---Max 4-1 1/4 oz  
 to start latch moving.  
 Hold transfer bail to left.

(A) TRANSFER BAIL DETENT PLATE

Requirement  
 Equal left and right clearance within 0.002  
 inch when transfer bail is at extreme left  
 or right position as these occur in a char-  
 acter between start and no. 1 pulses only.

To Adjust  
 Rotate detent plate right or left by means  
 of screwdriver with detent plate mounting  
 screws loosened.

(C) SIGNAL CONTACT CLEARANCE

To Check  
 Depress Y keylever and rotate signal generator cam sleeve until each contact has  
 fully opened.

Requirement  
 Marking and spacing gaps should be equal within 0.001 inch.

To Adjust  
 Loosen mounting screws and move contact box by means of eccentric.

Note 1: Check by means of signal checking device if available, and carefully refine  
 the adjustment to eliminate all bias from the signals by equalizing the current-on  
 and current-off intervals (2.17).

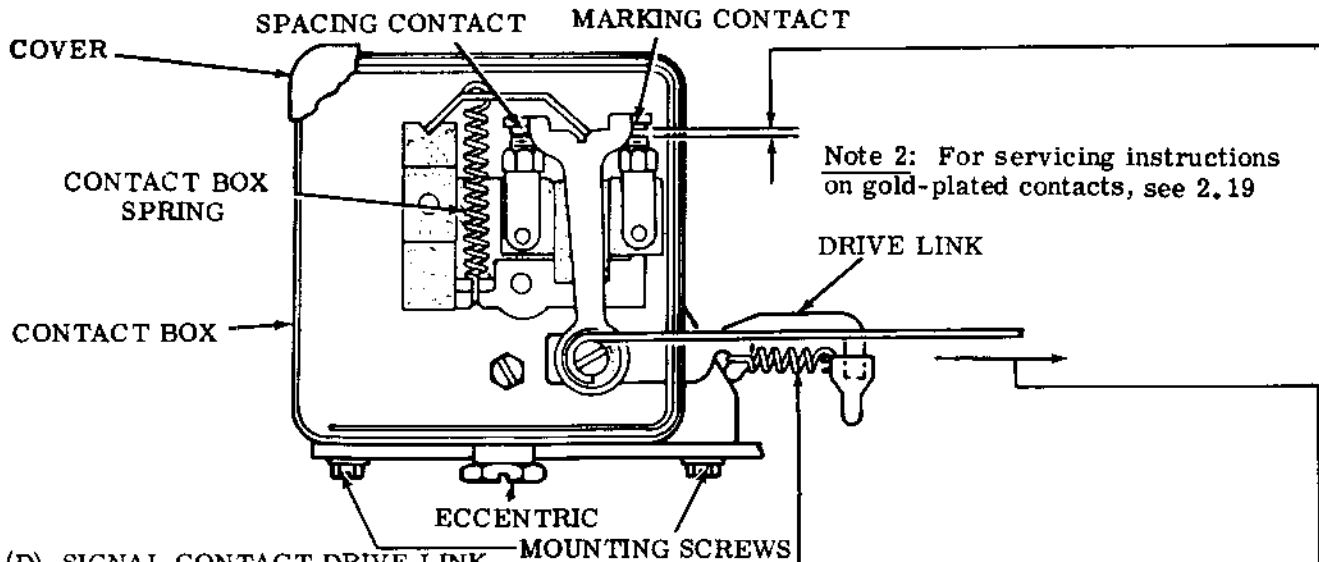

(D) SIGNAL CONTACT DRIVE LINK

Requirement  
 With main shaft in stop position and trans-  
 fer bail detent latch spring unhooked (see  
 figure above), move latches away from  
 transfer bail extension. Hold the toggle  
 firmly against contacts  
 Min 6 oz---Max 9 oz  
 to start transfer bail extension moving.

(E) SIGNAL CONTACT SPRING

Requirement  
 Remove drive link spring.  
 Transfer bail held clear of drive link.  
 Min 2 oz---Max 3 oz  
 to start link moving.

2.06 Codebar and Codelever Mechanism

(B) CLUTCH TRIPBAR SPRING TENSION

Requirement

Clutch disengaged. Power off  
Min 8 oz---Max 12 oz  
to move bar.

(C) CODEBAR SPRINGS (No. 1, 2, 3, 4, 5, 6, 7 and 8)

Requirement

Depress rub out or delete key. Power off. Transfer levers held right.  
Min 5 oz---Max 7-1/2 oz  
to start each bar moving.

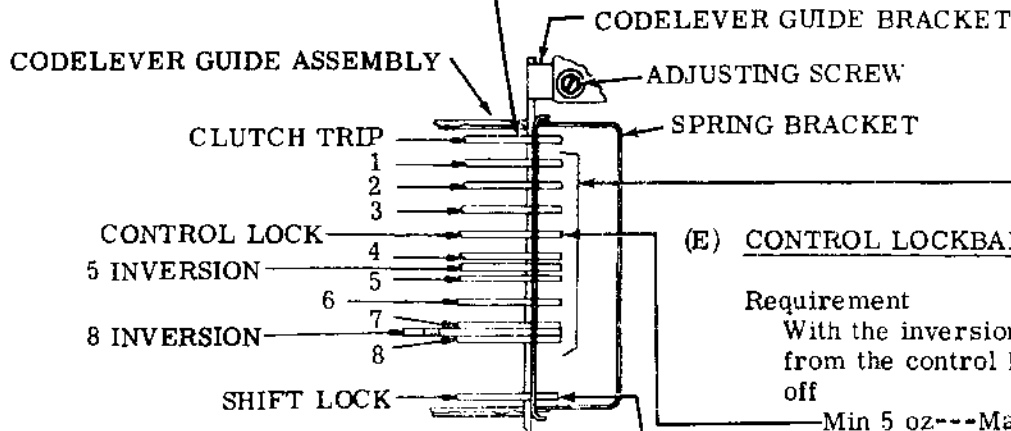

(E) CONTROL LOCKBAR SPRING

Requirement

With the inversion bail disengaged from the control lockbar and power off  
Min 5 oz---Max 7-1/2 oz  
to start control lockbar moving.

(D) SHIFT LOCKBAR SPRING

Requirement

With the inversion bail disengaged from the shift lockbar and power off  
Min 2 oz---Max 4 oz  
to start shift lockbar moving.

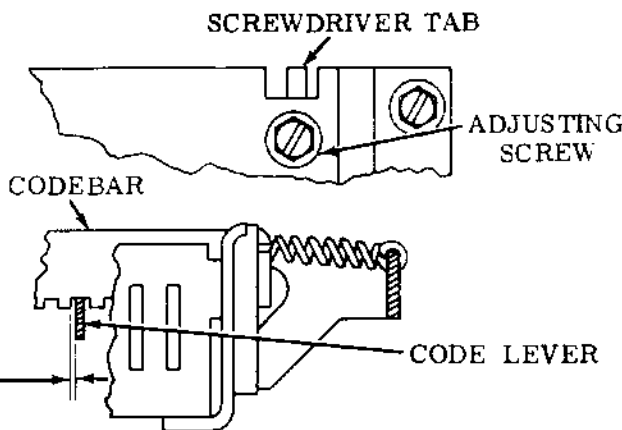

(A) CODEBAR AND CODE LEVER CLEARANCE

Requirement

Permutation must be such that the highest level (no. 8 level in an 8-level code) is spacing. The key code lever located furthest to the right should meet the requirement. While key is held down and cam cycled to stop position, gap between left side of key code lever and codebar blocked.

Min 0.006 inch---Max 0.017 inch

(F) NO. 5, 8 INVERSION CODEBAR SPRINGS

Requirement

Codebar in latched position. Unhook spring at guide  
Min 6 oz---Max 8 oz  
to pull to installed length.

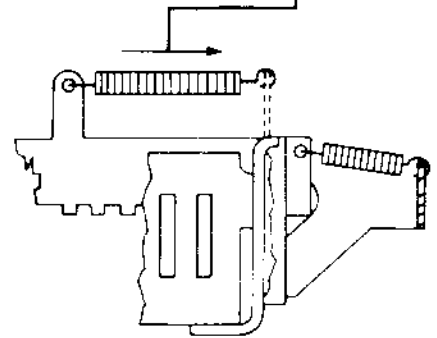

To Adjust

Position guide by adjusting slot with four mounting screws loosened. Tighten screws.

2.07 Function Bail and Lock Ball Track Mechanism

(A) FUNCTION BAIL LEVERS AND CODE LEVER CLEARANCE

Requirement

Function bails should operate within their guides without binding.

To Adjust

Position function bail assembly with two mounting studs loosened, one at each end.

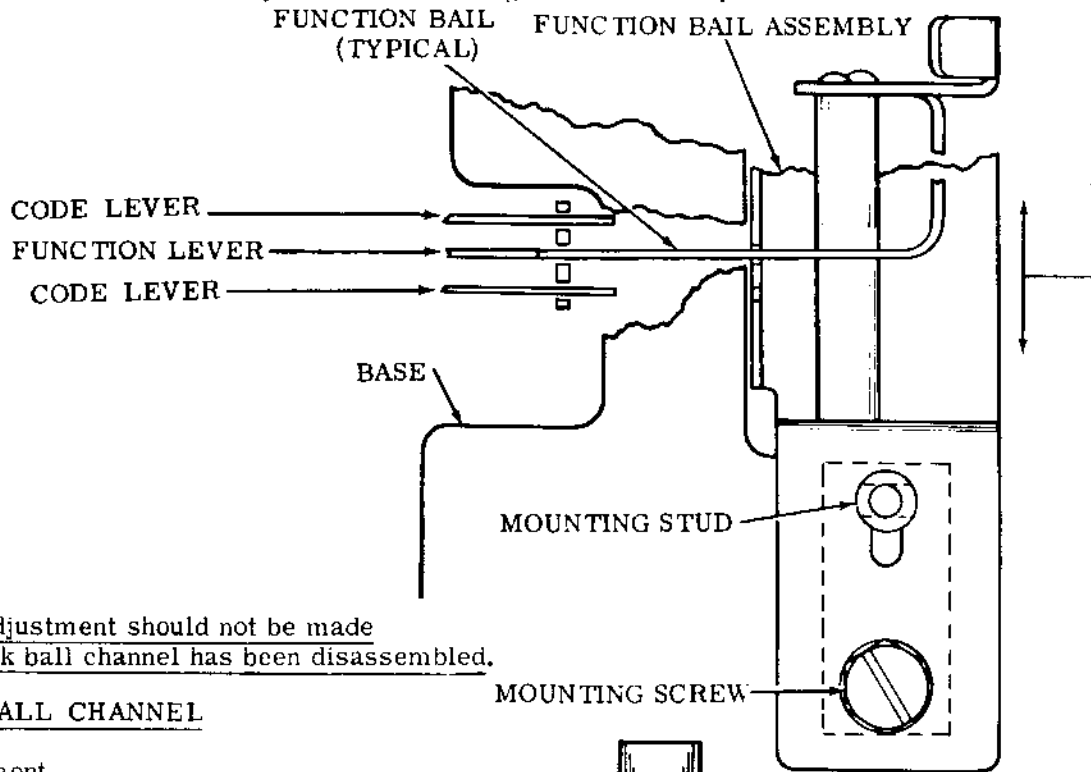

Note: This adjustment should not be made unless the lock ball channel has been disassembled.

(B) LOCK BALL CHANNEL

Requirement

There should be  
 — Min some---Max 0.006 inch  
 clearance between end of lock ball  
 channel and adjusting screw when  
 most of the code levers are centrally  
 located in the lock ball channel slots.

To Check

Remove the lock ball retainer. Remove  
 a wedge from each end and one from  
 the center in order to view the position  
 of the code lever.

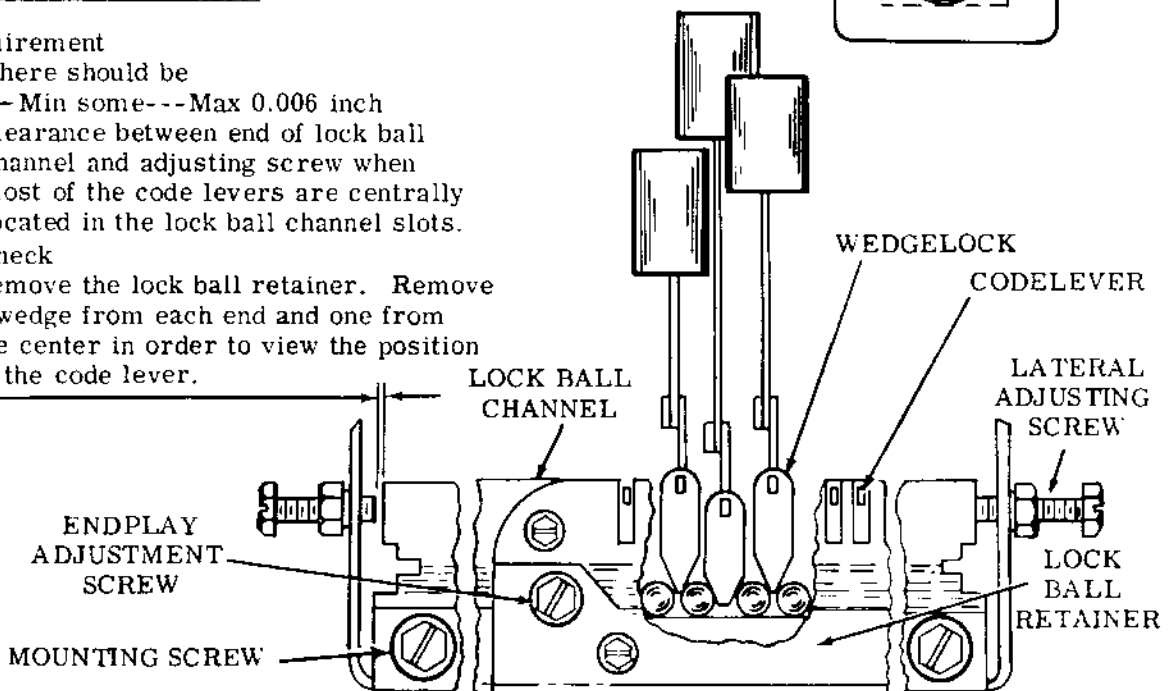

To Adjust

Loosen the lock ball channel mounting screws. Back off lateral adjusting screws  
 and position channel. Turn one adjusting screw in against the end of the channel and lock it.  
 Turn the other adjusting screw in to the end of the channel and back it off 1/4 turn. Lock  
 the screw. Replace the wedges and check their position with respect to the balls. Pull  
 channel assembly downward until all code levers strike their upstop without wedges jumping  
 out of position. Replace lock ball retainer. Back off ball endplay adjusting screw.

## 2.08 Codebar Bail Mechanism

CODEBAR RESET BAIL LATCH SPRING

## Requirement

Min 1/2 oz---Max 1-1/2 oz  
to start codebar reset bail latch moving.

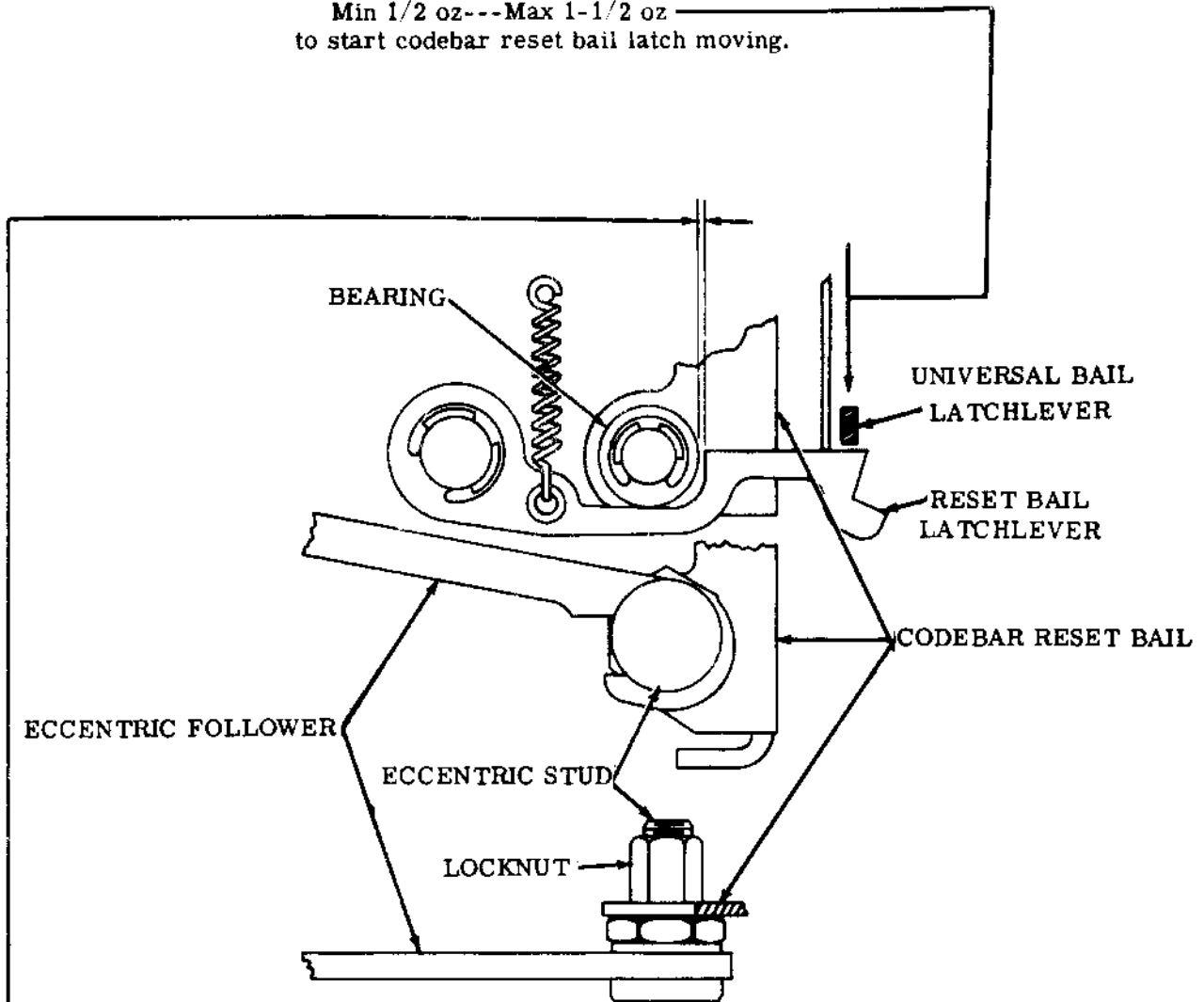
(A) CODEBAR RESET BAIL

## Requirement

Cam eccentric and arm holding bail in  
extreme reset position to left  
— Min some---Max 0.006 inch  
between roller bearing mounted on reset  
bail and reset bail latch.

## To Adjust

Adjust eccentric stud so that the high  
point is in the upper half of its adjust-  
ment arc.

2.09 Codebar Bail Mechanism (continued)

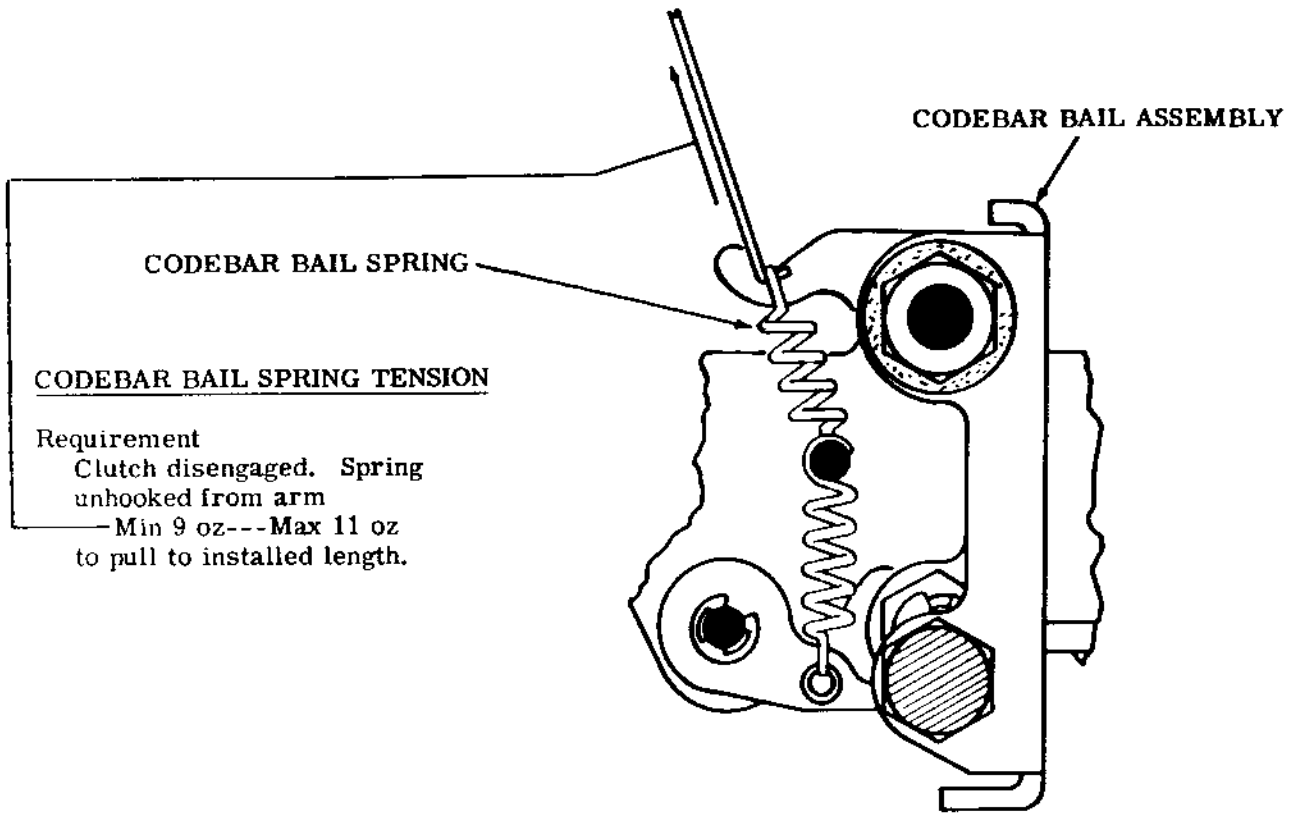

2.10 Keytop Guide Mechanism

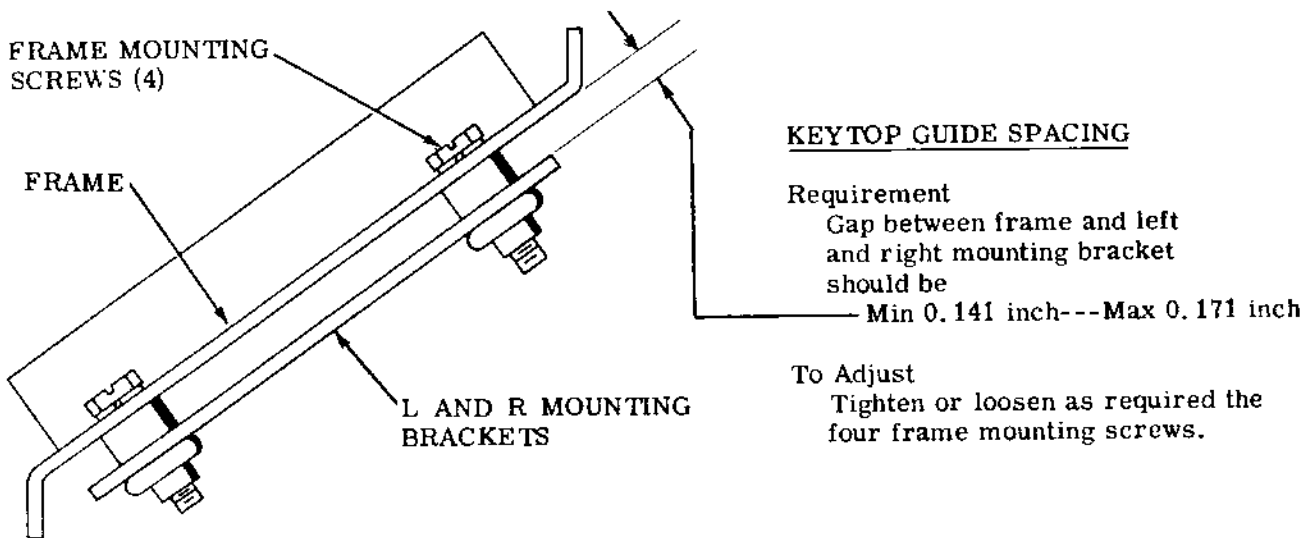

2.11 Nonrepeat Lever Mechanism

(B) NONREPEAT LEVER SPRING TENSION

Requirement  
Clutch disengaged, any keylever depressed  
Min 2-1/4 oz---Max 3-1/4 oz  
to start nonrepeat lever moving downward.

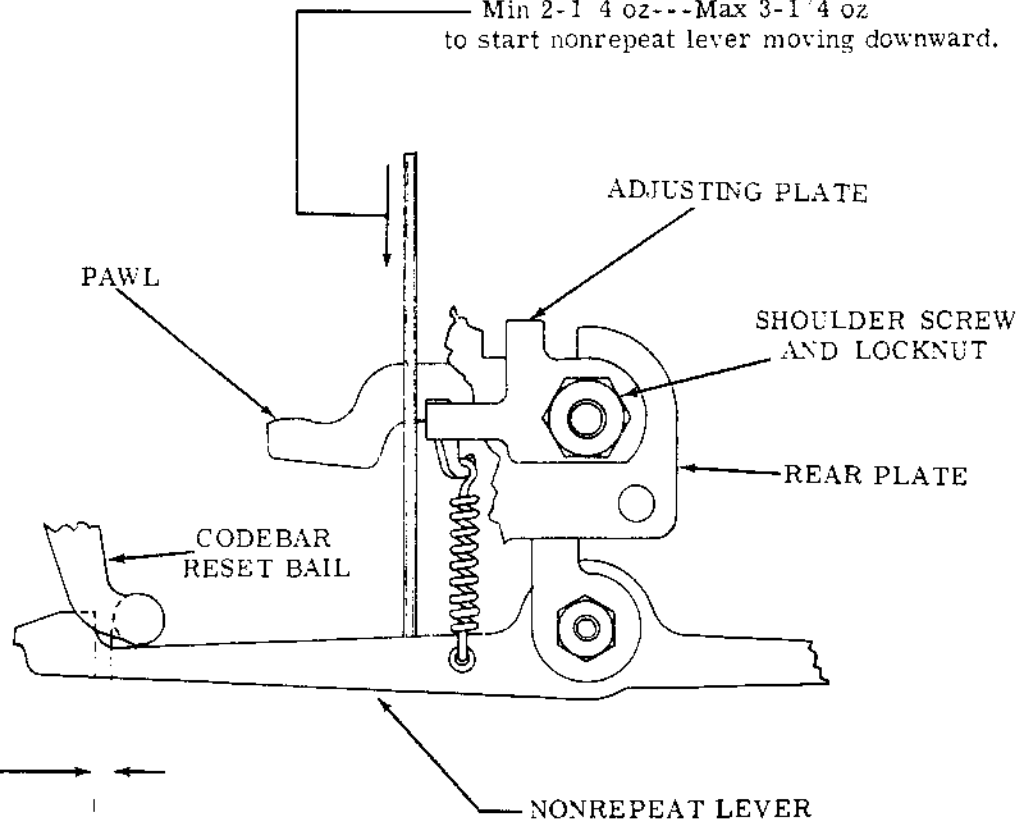

(A) CODEBAR RESET BAIL AND NONREPEAT LEVER

Requirement  
Mechanism in initial trip-off condition, any key depressed, no power  
Min some---Max 0.010 inch  
between roller of reset bail and nonrepeat lever pick-up step.

To Adjust  
Loosen locknut and shoulder screw and move mechanism left or right.

Note: Do not permit clutch to rotate when tripping off.

2.12 Wedge Lock and Ball Track Mechanism

Note: Remove keyboard hood in order to make this adjustment. See disassembly and reassembly.

(A) BALL WEDGE LOCK AND BALL TRACK CLEARANCE (PRELIMINARY)

To Check

Depress Q and P keylever alternately with 32 oz pressure and measure clearance in each instance. There should be no clearance between lower edge of code lever extensions and bottom of slots in wedges.

Requirement

Clearance between tip of wedge and the ball track

Min 0.005 inch---Max 0.015 inch

and equal within 0.005 inch.

To Adjust

Position ball track up or down with the two mounting screws loosened.

(B) LOCK BALL ENDPLAY (PRELIMINARY)

To Check (with ball endplay adjustment screw backed off)

Depress key at extreme right end of the A row with 32 oz pressure.

Requirement

Clearance between balls should be minimum.

To Adjust

Maintain 32 oz pressure and rotate adjusting screw with fingers until a slight resistance is felt. Tighten locknut.

Note: A total of 53 balls are required in the ball track assembly.

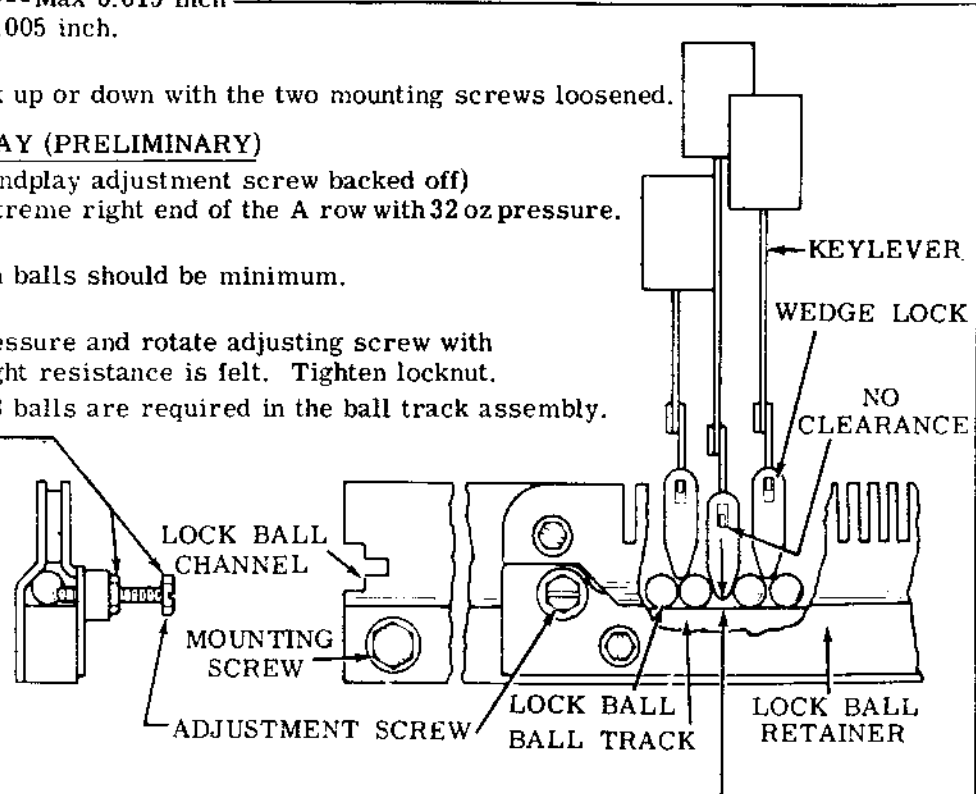

(C) BALL WEDGE LOCK, BALL ENDPLAY AND UNIVERSAL BAIL LATCH (FINAL)

Note: Perform this adjustment following UNIVERSAL BAIL EXTENSION (2.13) (Universal Bail Latchlever).

Requirement (under power)

- (1) Trip-off pressure of any key in row A should be  
Min 2 oz---Max 6 oz
- (2) Apply 6-1 2 oz pressure perpendicular to A key, depress each key in that row.  
The A key should trip each time a key is released.
- (3) Repeat (2) with the 6-1 2 oz pressure on extreme right key in that row.
- (4) The clutch should not trip when two keys are depressed simultaneously.
- (5) With 5-1 4 ± 1 4 oz applied to the spacebar, depress carriage return key.  
The spacebar should trip each time the carriage return key is released  
(by moving the finger off the key in a horizontal direction).

To Adjust

If necessary, refine BALL WEDGE LOCK AND BALL TRACK CLEARANCE (PRELIMINARY) (2.12), LOCK BALL ENDPLAY (PRELIMINARY) (2.12), UNIVERSAL BAIL LATCHLEVER (PRELIMINARY) (2.13), and UNIVERSAL BAIL EXTENSION (2.13).



2.13 Universal Bail Latchlever

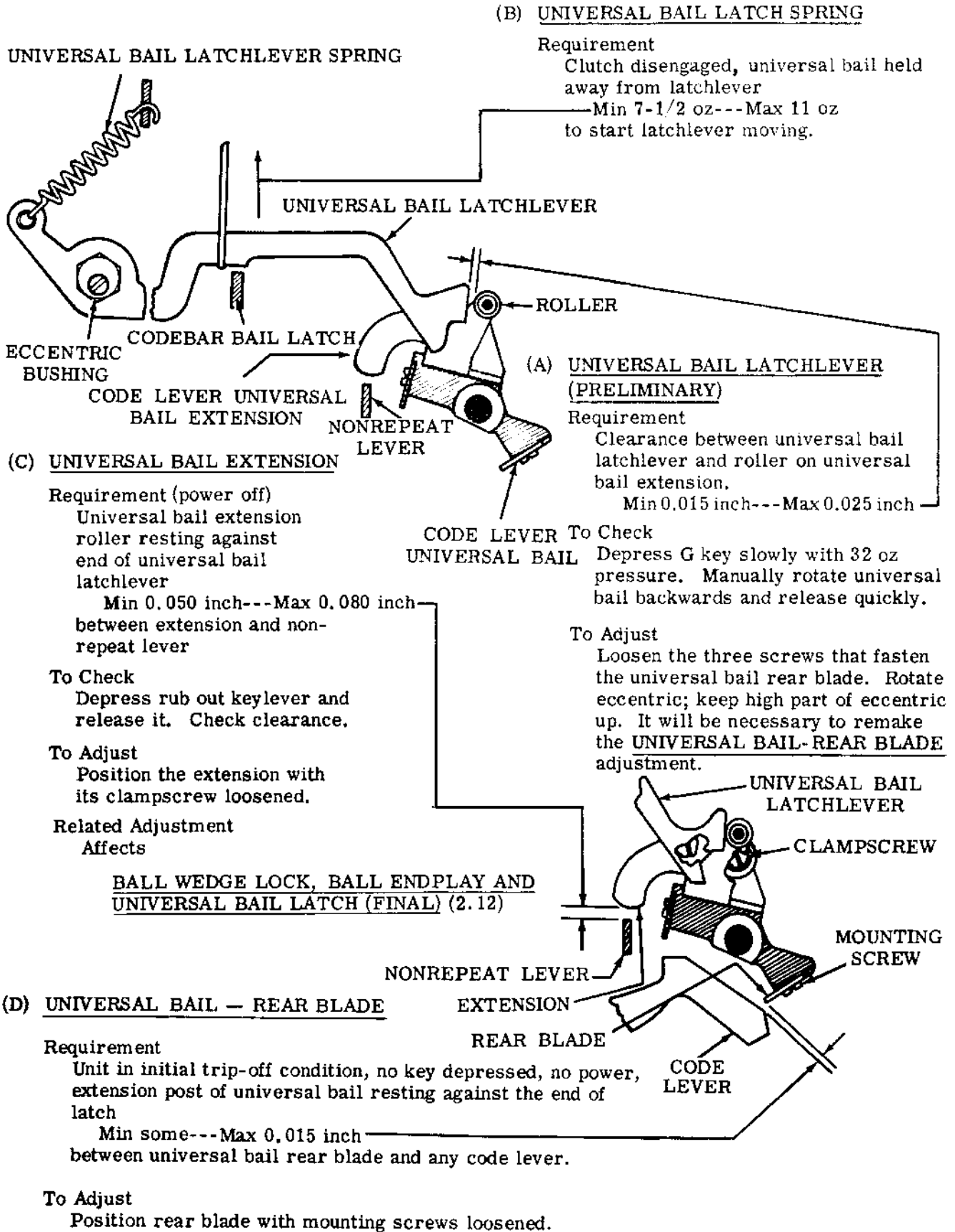

2.14 Local Line Feed Trip Link Mechanism

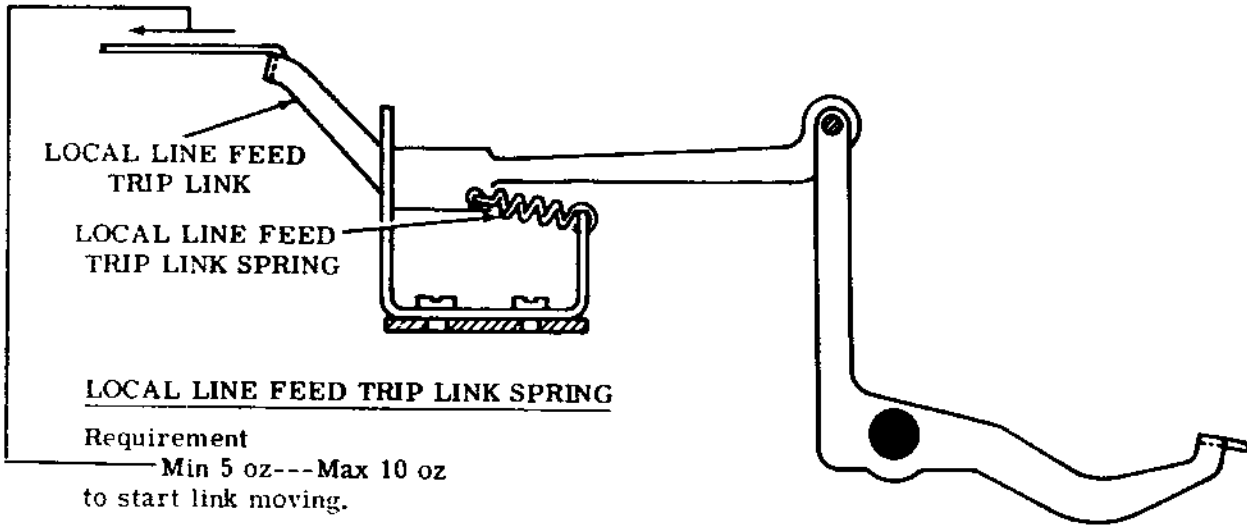

2.15 Inversion Codebar Latch Mechanism (Earlier Design)

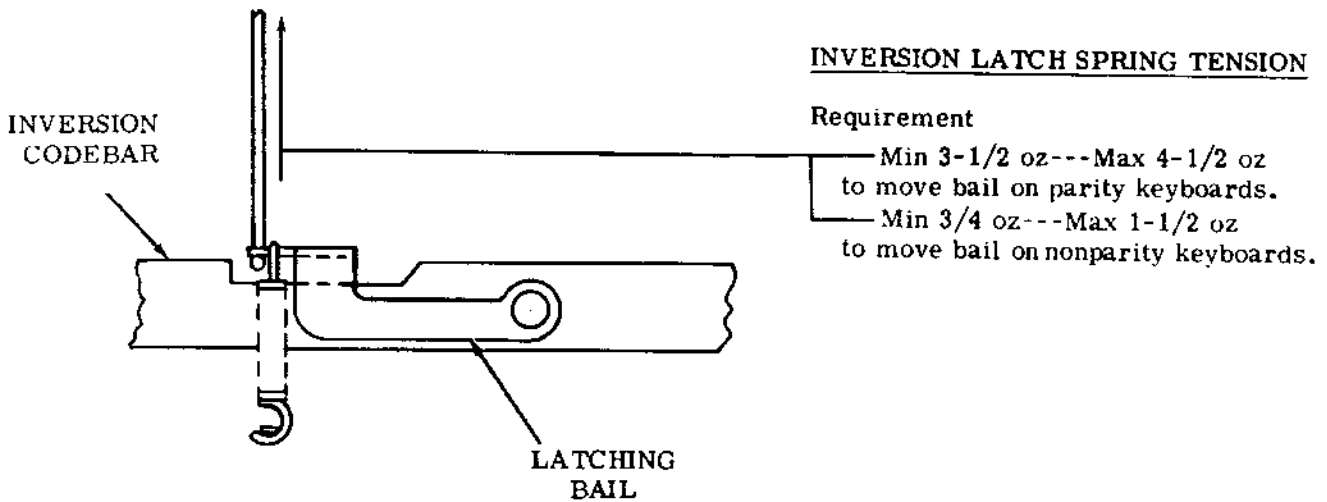

INVERSION CODEBAR LATCH (EARLIER DESIGN)

Requirement  
Signal generator disengaged  
Min 0.002 inch---Max 0.012 inch  
gap between inversion codebar and its latch.

To Adjust  
With screw on inversion bail friction tight,  
move adjustable extension to obtain clearance.

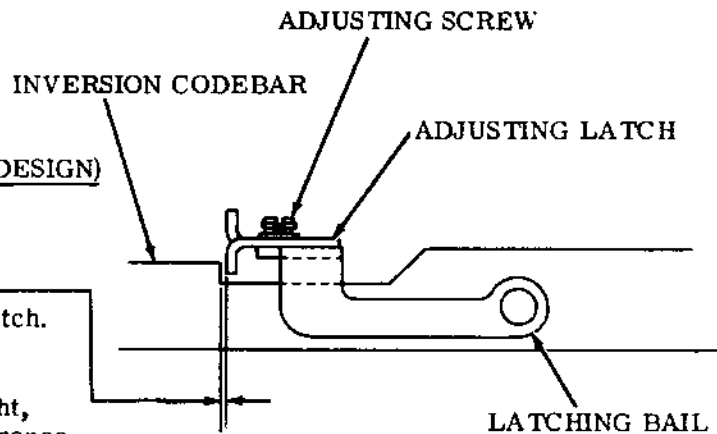

2.15 Inversion Codebar Latch Mechanism (Later Design)

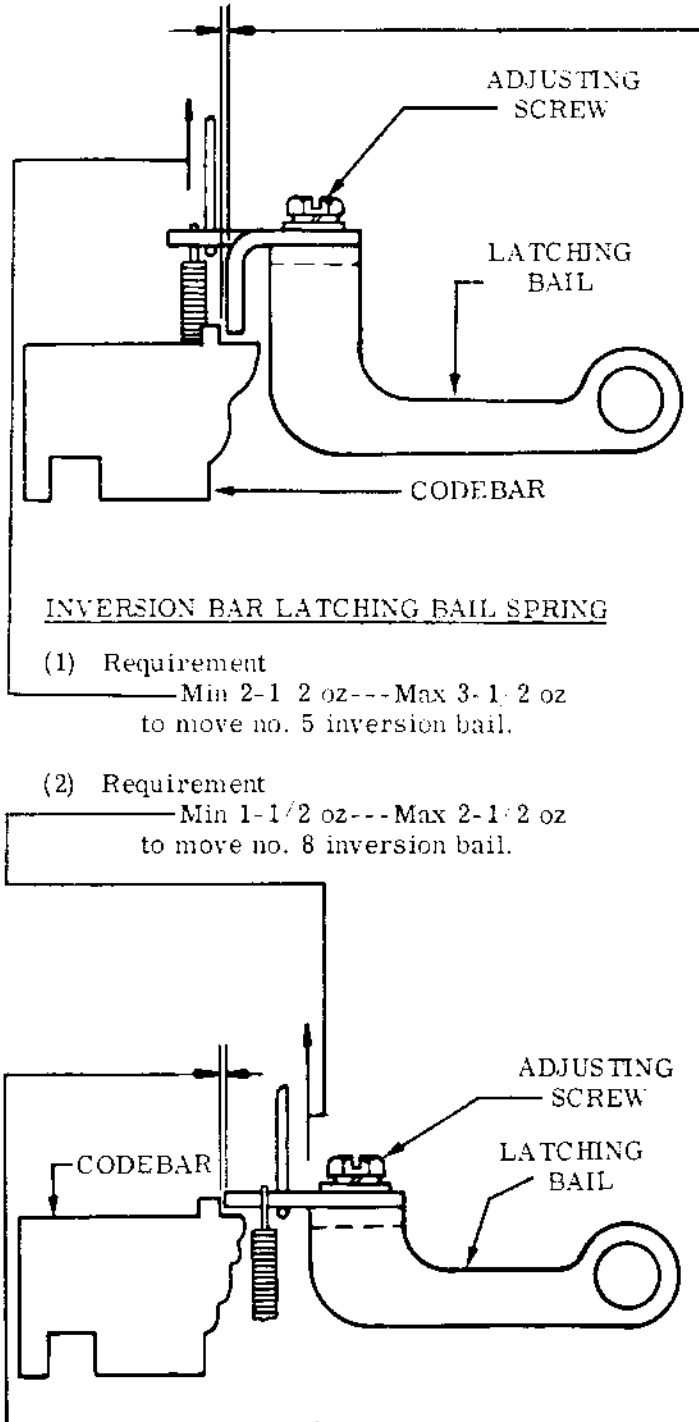

INVERSION CODEBAR LATCH  
(LATER DESIGN)

Requirement

Signal generator clutch disengaged.  
 Min 0.002 inch --- Max 0.012 inch  
 gap between number 5 and 8 inver-  
 sion codebars and their respec-  
 tive latches. Check clearance at both the  
 number 5 and 8 inversion codebars  
 and adjust to whichever is closest.

To Adjust

With respective screws on inversion  
 bail latch friction tight, move  
 adjustable extension to obtain  
 clearance. Tighten screws and  
 recheck clearance.

2.17 Signal Contacts

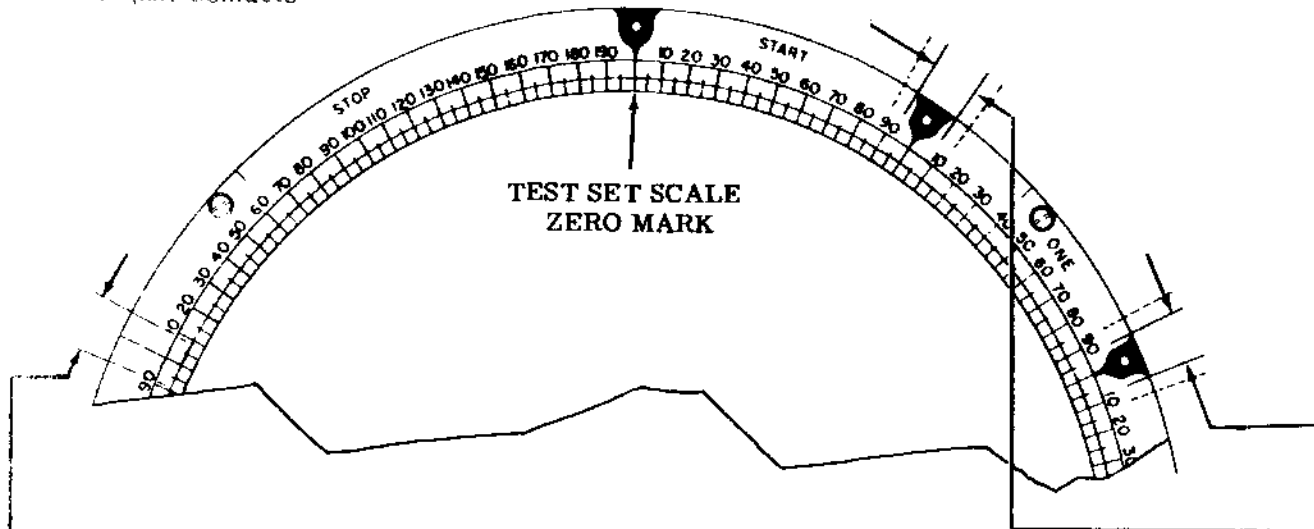

SIGNALING CODE CONTACT (STROBING) (Using DXD test set, if available)

Procedure

- (1) Disconnect arc suppressor or rf filter. Reconnect signal generator contacts so current to stroboscope lamp of DXD test set is interrupted. Synchronize signal generator with DXD so end of stop pulse image is in line with 0 mark of start pulse on DXD scale when transmission is continuous and both units are operating at 100 speed (600 rpm).

Note 1: End of stop pulse image not to vary from 0 mark more than 1/2 division. If variation occurs, adjust scale so variation extends equally to either side of 0 mark.

Note 2: For units equipped with signal regenerators, remove regenerator circuit card before applying test set probes to signal contacts.

**CAUTION: APPLYING OPERATING VOLTAGE OF SIGNAL DISTORTION TEST SET DIRECTLY TO GOLD-PLATED SIGNAL CONTACTS MAY MAKE THEM UNSUITABLE FOR SPECIAL LOW-VOLTAGE APPLICATIONS. SEE 2.19 FOR SERVICING INSTRUCTIONS.**

Note 3: Numbers in parenthesis ( ) are for units using timing contacts for signal regenerators.

- (2) Nominal length of intelligence pulses is 100 divisions. If adjustment to feeler gauges does not permit pulse lengths within tolerance, refine contact box adjustment. Favor intelligence pulses by using up the designated tolerances of stop pulse so each is near as possible to 100 divisions in length.

Requirements

- (1) Each marking code pulse to begin not later than 8 (12) mark and no earlier than 92 (88) mark of previous pulse.
- (2) Each marking code pulse to end not earlier than 92 (88) mark or later than 8 (12) mark in pulse following one being observed.
- (3) Marking code pulses may have break not more than three divisions wide and occurs only at end of code pulse image between the 92 (88) mark and end of image.
- (4) Stop image should not change in length or position more than one division while changing from R to Y selector (or equivalent permutations for other codes).

## 2.18 Signal Contacts (continued)

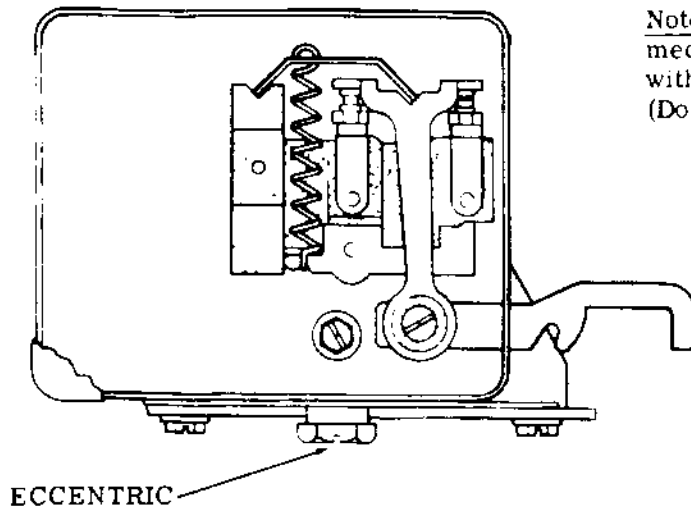

**Note 4:** If necessary, reposition stabilizer mechanism so end of stop image coincides with 0 mark of start pulse on scale. (Do not remove scale.)

- (5) DXD strobing should yield allowable spacing signal distortion of  $\pm 12\%$ .

**To Adjust**

Loosen mounting screws and move contact box by means of eccentric.

## 2.19 Gold-Plated Signal Contacts

(a) Units may have signal contacts made of either unplated or gold-plated tungsten. If in doubt as to the type of contacts, remove signal generator cover and inspect contacts for gold plating.

## (b) Cleaning

- (1) Use twill jean cloth (KS2423) to clean gold-plated contacts.
- (2) Open contacts. Drop strip of twill jean between them. Close contacts. Draw twill jean part way through. Open contacts and withdraw twill jean.
- (3) This procedure prevents small fibres at edges of twill jean strip from becoming lodged between contacts.
- (4) Clean unplated tungsten contacts in accordance with standard procedures.

## (c) Servicing for special low-voltage applications.

- (1) For standard applications including those with data sets, observe standard maintenance procedures and intervals. Special low-voltage applications are covered below.

- (2) For optimum reliable operation in special low-voltage applications, clean gold-plated contacts with twill jean, as instructed above. The recommended cleaning interval for gold-plated contacts in special low-level applications (less than 250 microwatts) and having an average weekly use of 60 hours should not exceed 90 days. This interval may be reduced, dependent on the signal circuit configuration, usage, and environment.

**Note 1:** Applying operating voltage of standard distortion test set directly to contacts may damage gold plating and impair special low-voltage operation. When electrically adjusting or testing contacts (2.17) use an intermediate device, keyed by the contacts, to interrupt current to stroboscopic lamp of test set. This intermediate device must be capable of being keyed by a 3 to 20 volt change at maximum of 20 milliamperes.

**Note 2:** Normally for special low-voltage applications, contacts should be used in circuits operating between 3 and 20 volts dc at a current level not to exceed 60 milliamperes. Between 20 and 70 volts dc the current should be adjusted so as not to exceed a 120 milliwatt power level. The contacts are not normally intended for use on voltages above 70 volts dc. Exceeding this level for an appreciable length of time may result in damage to the gold plating and make them unfit for special low-voltage applications.

2.20 Code Lever and Local Carriage Return Function Bail Mechanism

CODE LEVER SPRING TENSION

- (1) Requirement  
Min 1 oz---Max 2 oz  
to start code lever moving downward.
- (2) Requirement  
Power on. Generator clutch disengaged  
Min 3 oz---Max 5 oz  
to operate keylever or spacebar.

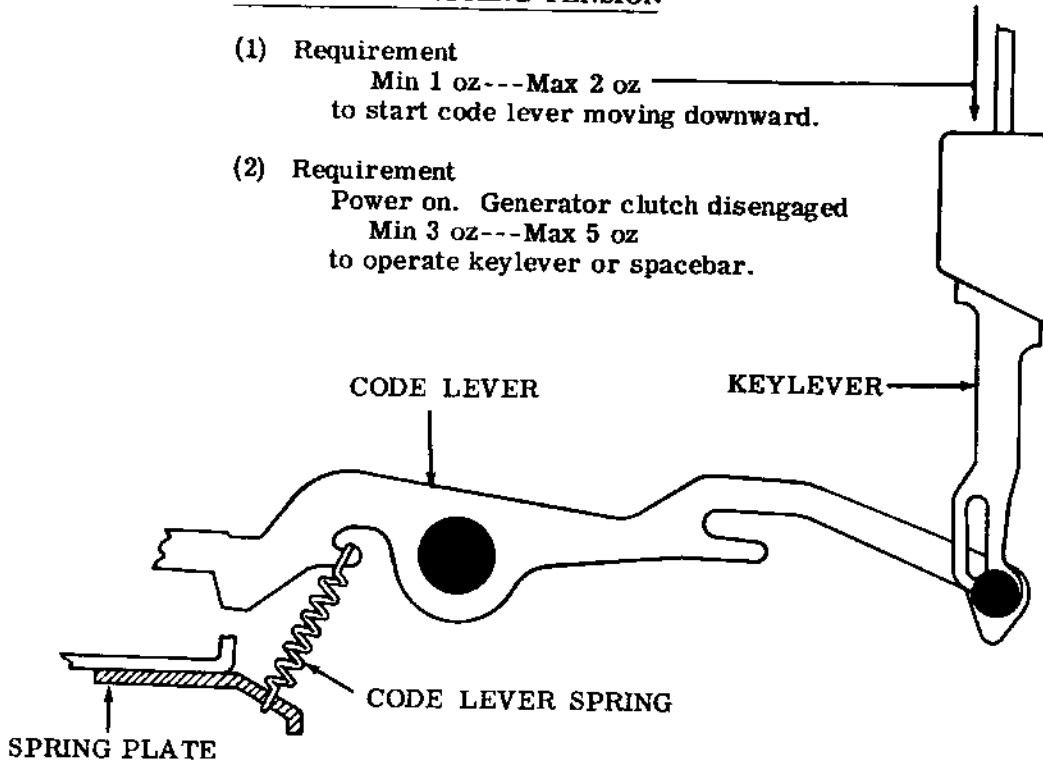

LOCAL CARRIAGE RETURN FUNCTION BAIL SPRING TENSION  
(COMBINED CODE LEVER AND BAIL SPRING)

- Requirement  
Min 1 oz---Max 3 oz  
to move keylever downward.

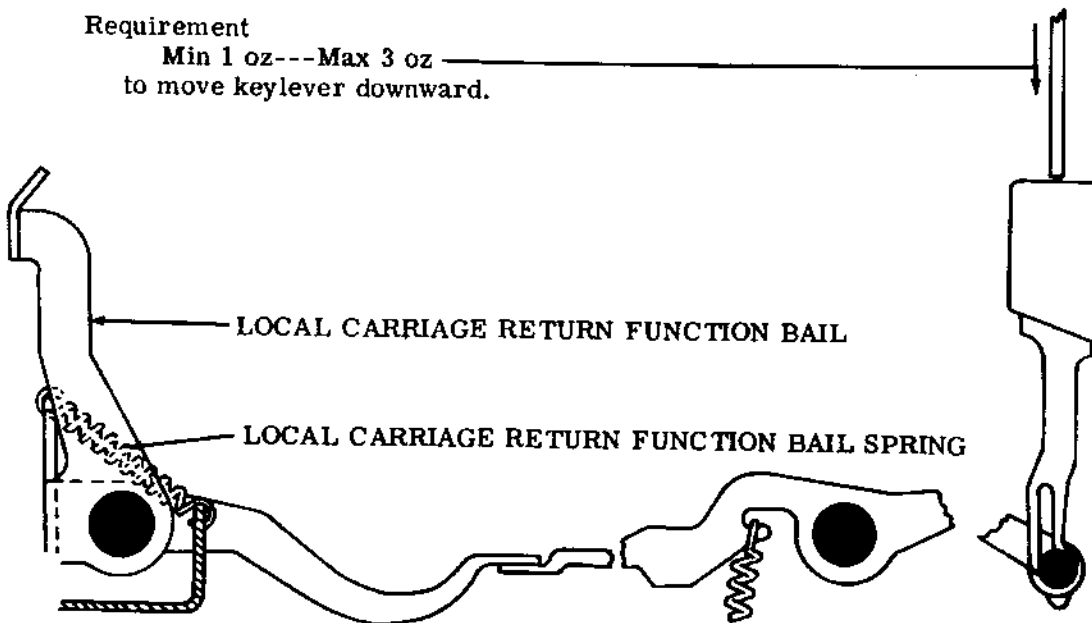

2.21 Transfer Lever and Margin Indicator Mechanism

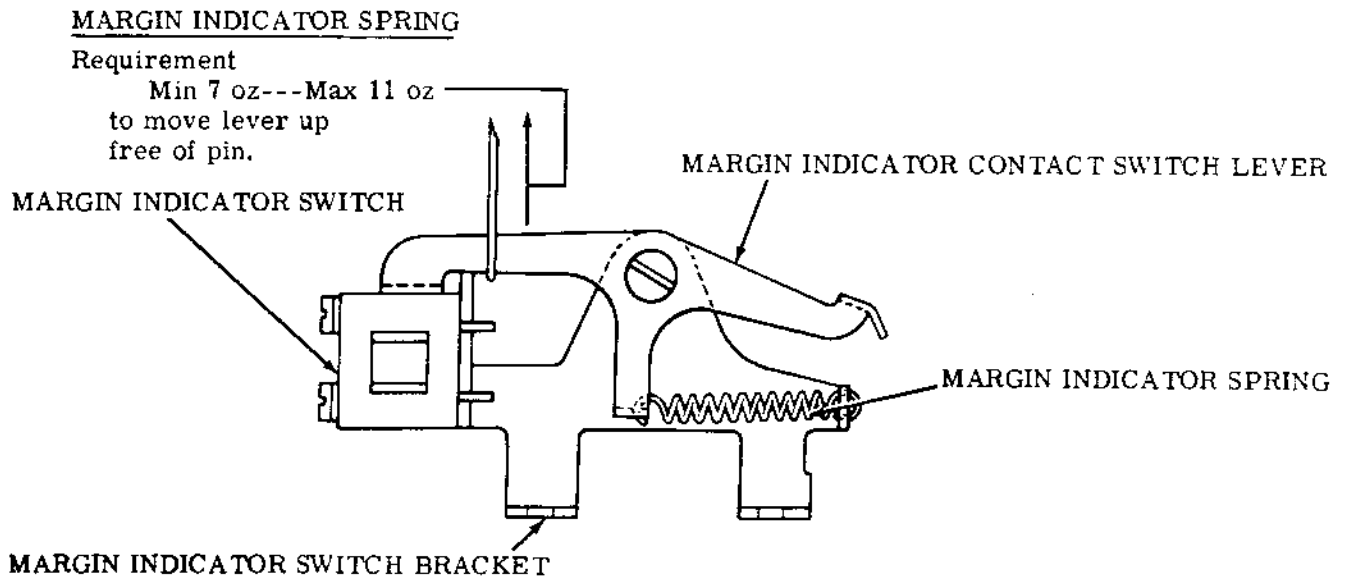
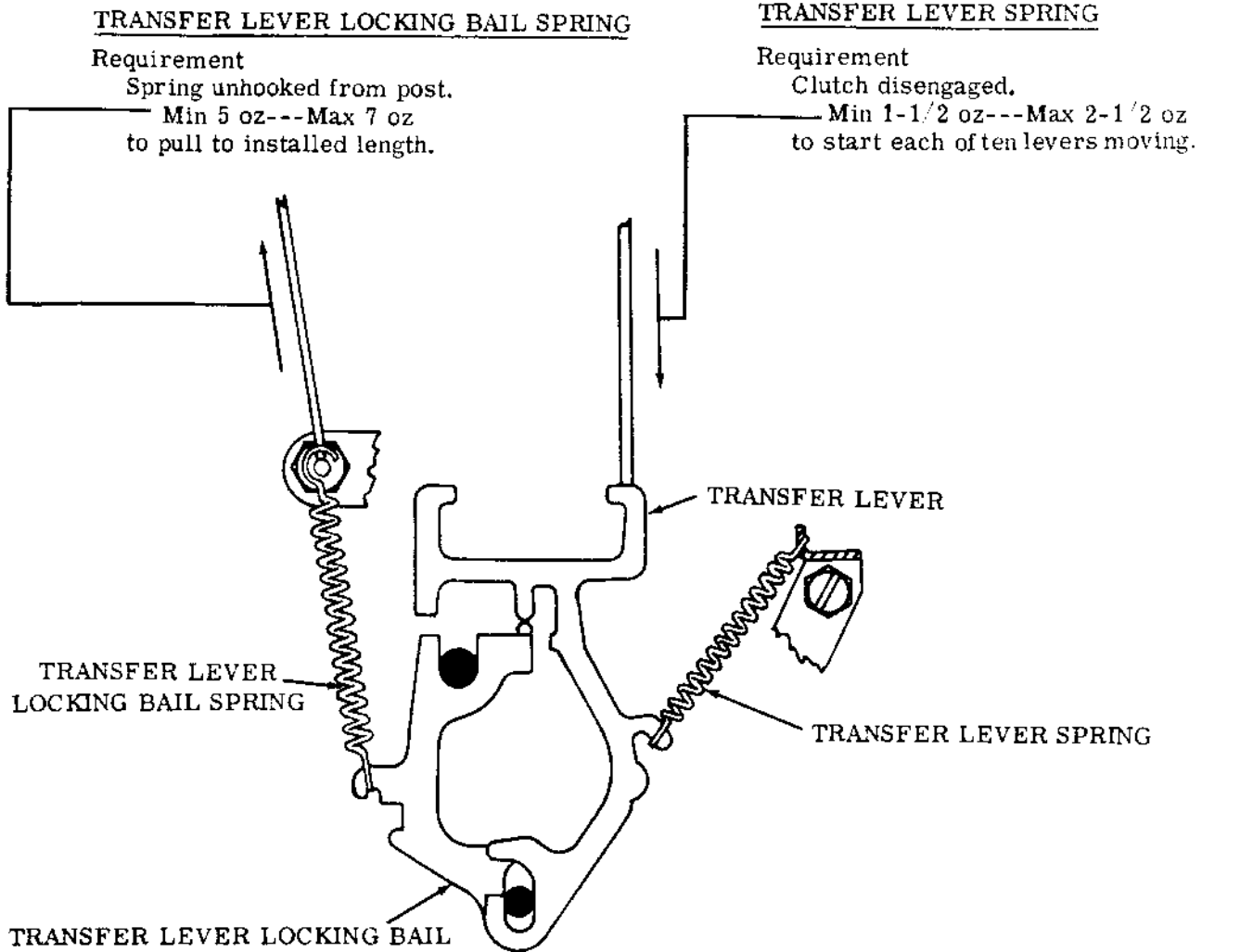

SECTION 574-221-700TC

2.22 Mounting Typing Unit on Keyboard or Base

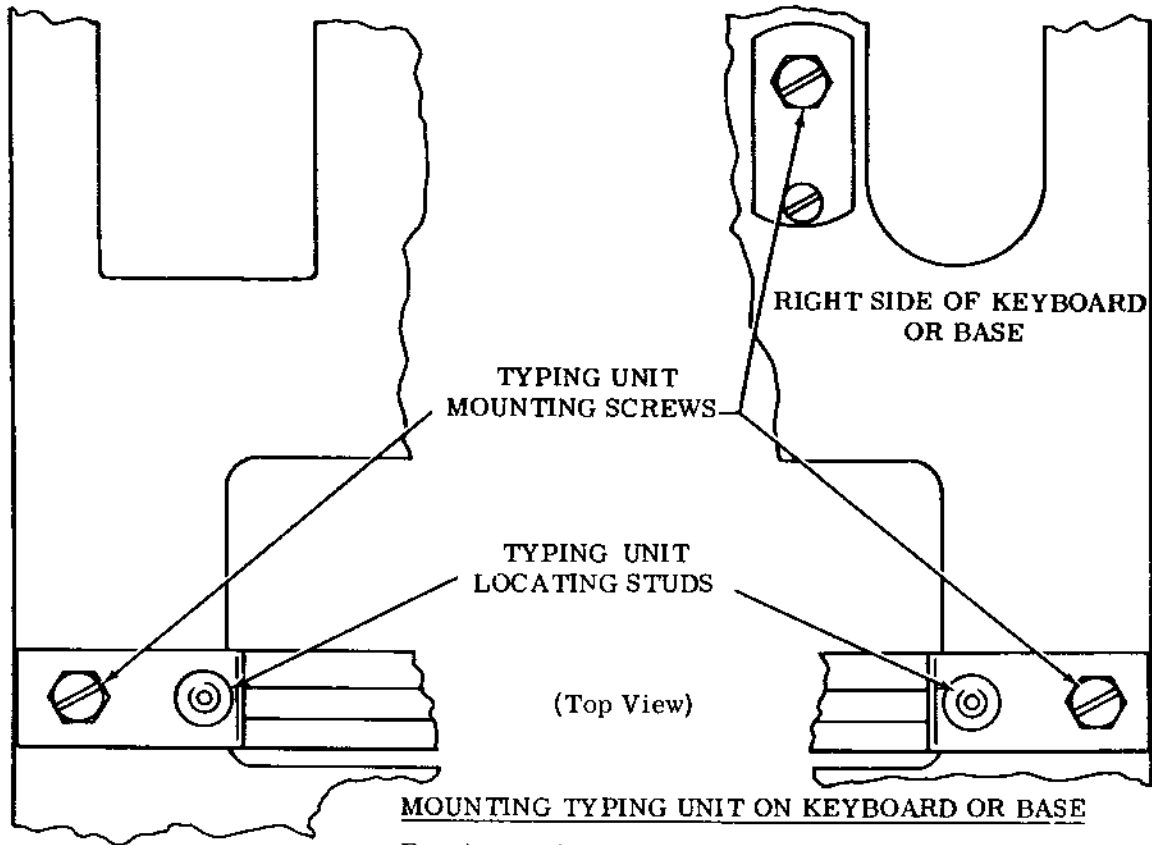

Note: Similar requirement for wall mounted printer. See 2.24 and Figure 2.

Requirement

When placing the typing unit on the base, hold it tilted slightly to the right and lower the right end into engagement with the right locating stud. While easing the left end downward, rotate the motor by hand to properly mesh the gears. Secure by four mounting screws. Rotate the motor by hand to insure proper meshing of gears.

SIGNAL GENERATOR FRAME

Requirement

With typing unit mounted in position, there should be a perceptible amount of backlash between the signal generator driven gear and the signal generator driving gear at the point where backlash is the least.

To Adjust

Remove the signal generator frame rear mounting screw and loosen the shim screw. Add or subtract shims as required.

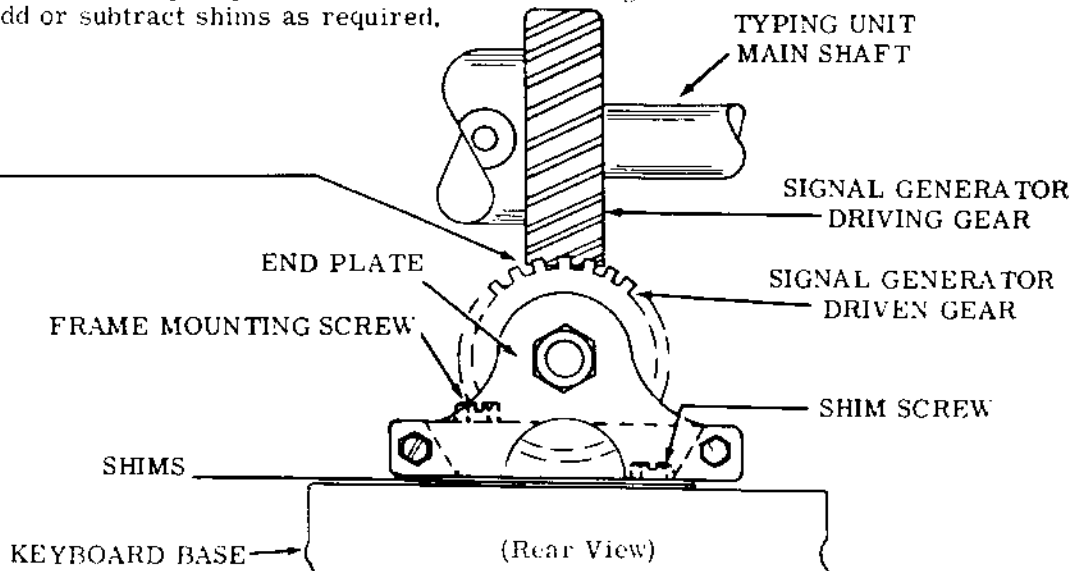



## 2.23 Keyboard or Base, Motor and Typing Unit Gearing

Note 1: Not applicable to wall mounted printer. See 2.24.

Note 2: This requirement should be checked with typing unit mounting screws tight.

INTERMEDIATE GEAR ASSEMBLY

## Requirement

Backlash between motor pinion and its driven gear, and between typing unit main shaft gear and its driving gear

Min 0.004 inch---Max 0.008 inch  
as gauged by feel.

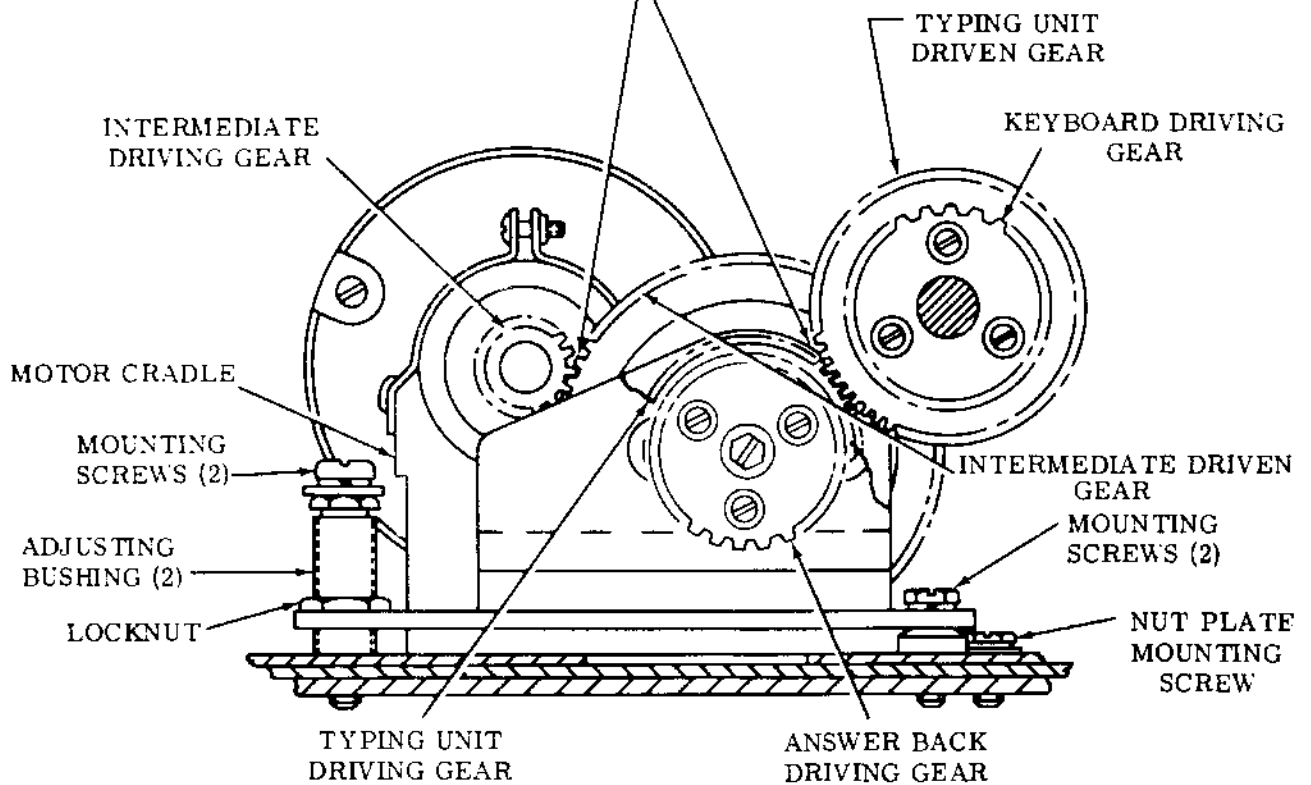

## To Adjust

Loosen intermediate gear assembly mounting screws (4). Loosen two locknuts which lock adjusting bushings at rear of assembly. Loosen nut plate mounting screw just in front of gear bracket. Move assembly backward or forward and adjust height at rear by means of adjusting bushing nearest motor (back out other bushing for clearance after correct adjustment is obtained). Lock adjusting bushing nut, turn other bushing with fingers until it touches base, and tighten locknut.

2.24 Keyboard Wall Mounted Base, Motor and Typing Unit Gearing

WALL MOUNTED INTERMEDIATE GEAR ASSEMBLY

(1) Requirement

Clearance between driven gear on printer and intermediate gear should be

Min 0.004 inch --- Max 0.008 inch

To Adjust

Loosen three mounting screws and make them friction tight. Position the assembly toward front or rear to meet requirement.

(2) Requirement

There should be some clearance between right belt retainer on intermediate gear assembly and spacing cutout lever on printer.

To Adjust

Position the assembly toward the left to meet requirement. Tighten screws.

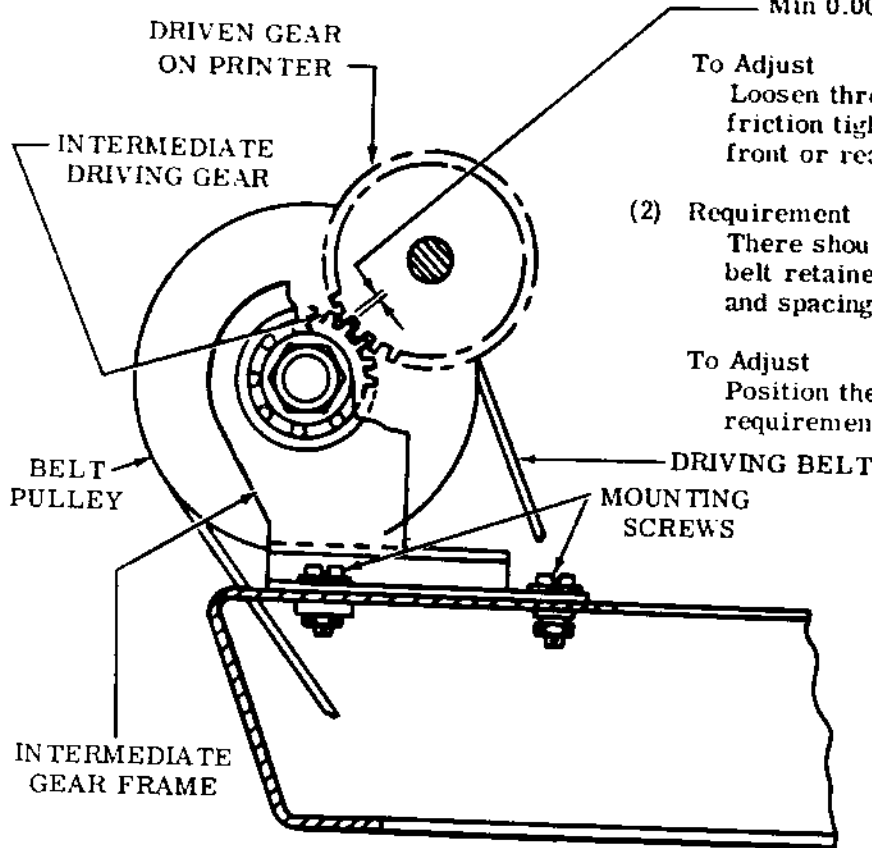

TIMING BELT

Requirement

Force of  $2 \pm 1/2$  oz to deflect belt  $1/8$  inch when measured midway between pulleys.

To Adjust

With motor plate mounting screws loosened, slide motor toward front of base to increase tension or toward rear of base to decrease tensions. Tighten screws.

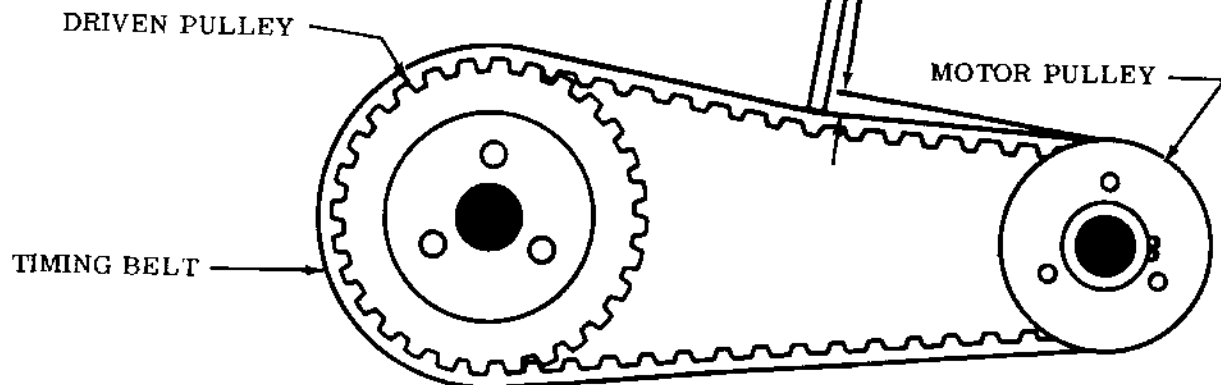

The following list of keyboard adjustments, plus those shown in Par. 2.25 and Par. 2.26 constitute the adjustments for an RO base.

<u>ANSWER-BACK MAIN SHAFT GEAR (if so equipped)</u> -----	Par. 3.01
<u>INTERMEDIATE GEAR ASSEMBLY</u> -----	Par. 2.23
<u>WALL MOUNTED INTERMEDIATE GEAR ASSEMBLY</u> -----	Par. 2.24
<u>FUNCTION BAIL LEVERS AND CODE LEVER CLEARANCE</u> ---	Par. 2.07
<u>MARGIN INDICATOR SPRING</u> -----	Par. 2.21
<u>MOUNTING TYPING UNIT ON KEYBOARD OR BASE</u> -----	Par. 2.22

2.25 Local Carriage Return Function Bail Mechanism

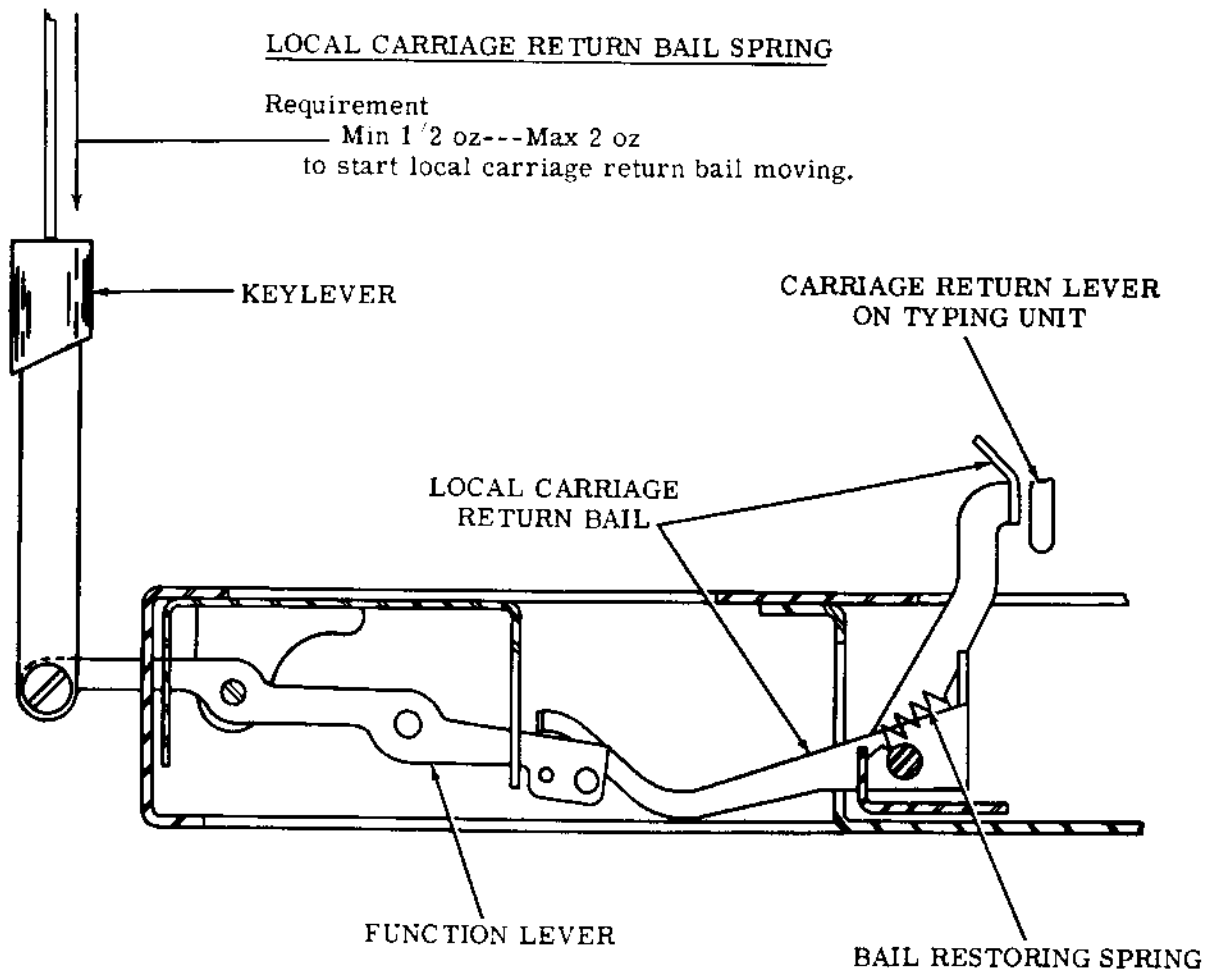

2.26 Local Line Feed Mechanism

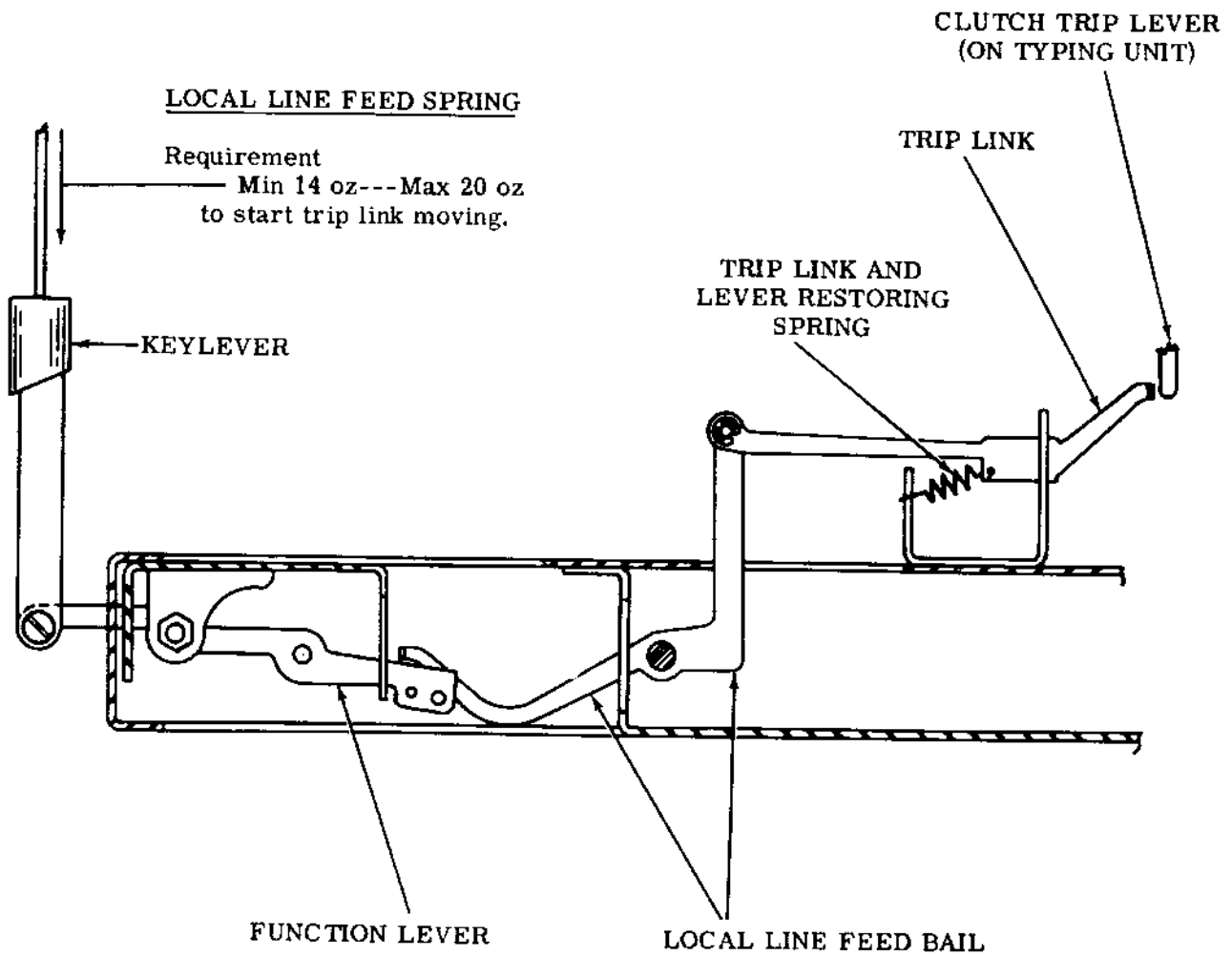

## 3. VARIABLE FEATURES

## 3.01 Answer-Back Mechanism

Note 1: See appropriate section for adjustments of the answer-back mechanism. Not applicable to wall mounted printer.

ANSWER-BACK MAIN SHAFT GEAR

## Requirement

There should be

Min 0.004---Max 0.008

backlash at the point of minimum clearance between the answer-back main shaft gear and the outboard gear of the intermediate gear assembly on the keyboard or base. Gauge by feel.

## To Adjust

With two nut plate screws tightened to friction tight, loosen the four answer-back mounting screws. Taking up all play in the answer-back mounting holes toward the front of the answer-back, position the assembly until the requirement is met. Tighten all screws. The answer-back assembly may be removed and replaced without remaking the adjustment by taking up all play in the mounting holes in the same manner.

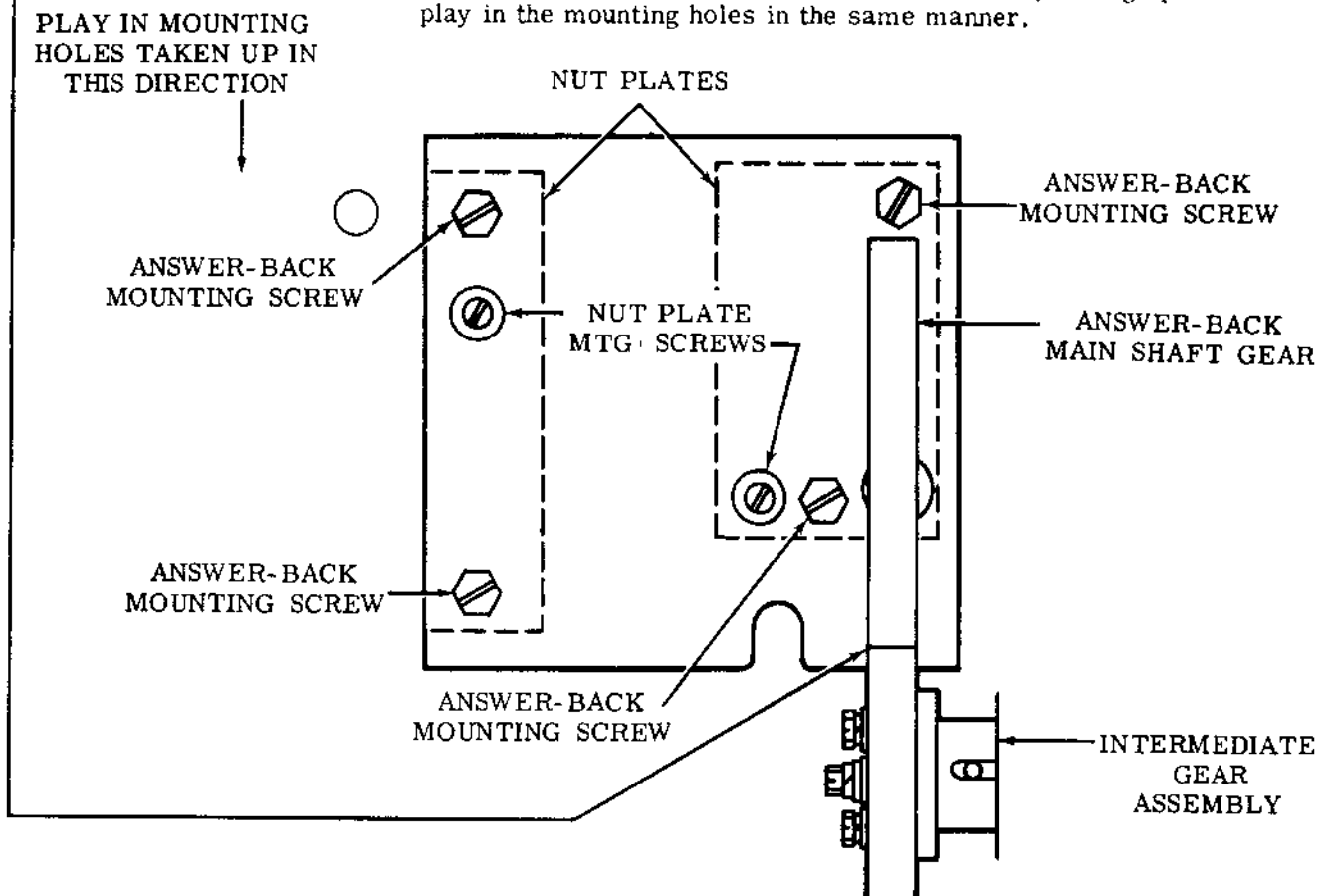

Note 2: This adjustment is made after the intermediate gear assembly to typing unit gear adjustment and motor pinion gear adjustments have been made.

3.02 Timing Contact Mechanism (Early Design)

TIMING CONTACT

(1) Requirement

Contacts should be closed when nylon pad is raised 0.007 inch.

Contacts should be open when nylon pad is raised 0.015 inch.

Note 1: Identification mark viewed on top side of hex and follower on low part of cam.

(2) Requirement

Min 0.003 inch
gap between contacts with the follower on any peak of cam.
Min 0.002 inch
gap on units prior to serial #88,800.

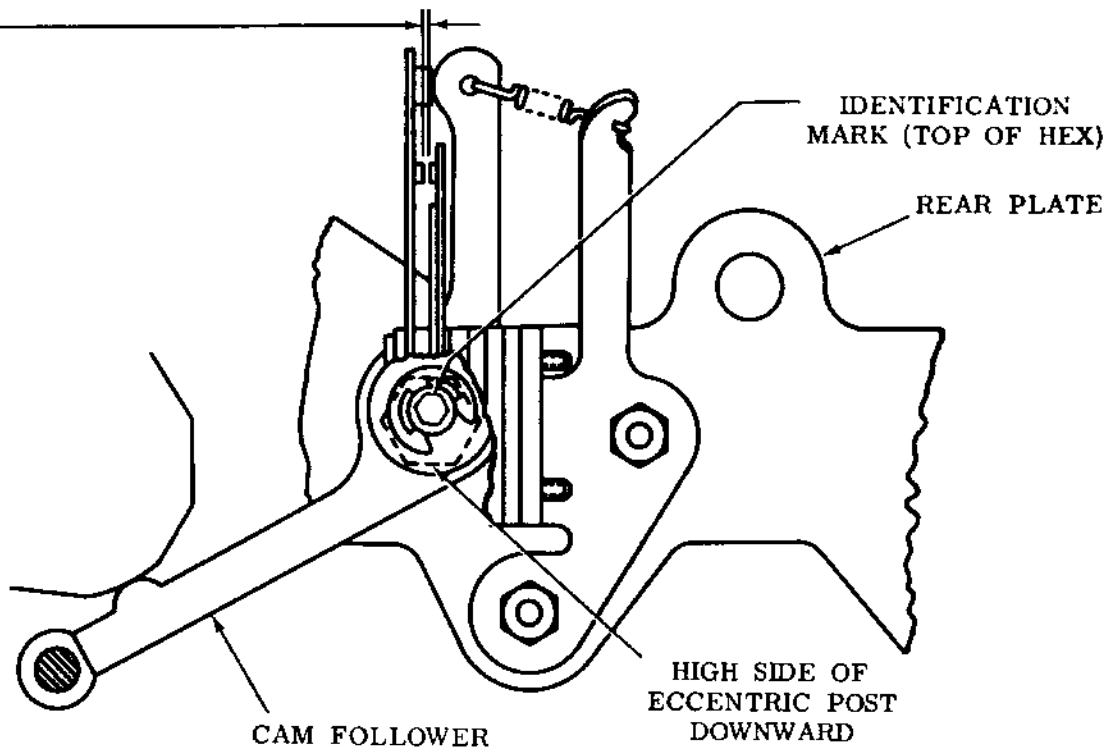

To Adjust

Loosen two timing contact bracket posts. With screwdriver between bracket upright and rear plate adjust gap

Min some---Max 0.010 inch

Adjust eccentric screw to meet (2) Requirement.

Note 2: Use signal checking device to refine this adjustment.

3.03 Timing Contact Mechanism (Early Design) (continued)

TIMING CONTACT SWINGER SPRING

Requirement

Contacts closed  
Min 2 oz---Max 3-1/2 oz  
to just open contacts.

To Adjust

Use spring bender TP110455.

TIMING CAM FOLLOWER SPRING

Requirement

Signal generator latched. Contact  
spring held back  
Min 6 oz  
to start cam follower moving.

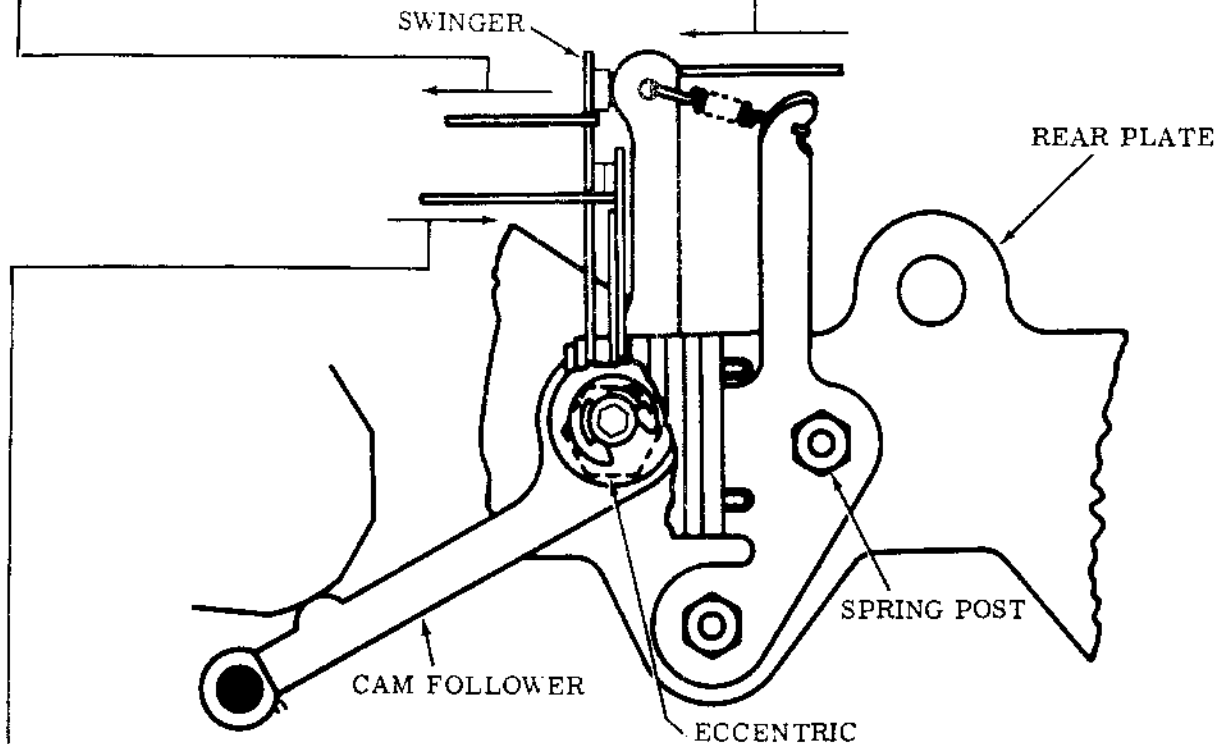

TIMING CONTACT STIFFENER SPRING

Requirement

Contact open  
Min 5 oz---Max 8 oz  
to move contact.

To Adjust

Remove contact assembly from unit by removing two studs securing it to rear plate. Loosen two screws holding contact pile-up to contact assembly bracket and bend contact using spring bender TP110455 until requirement is met.

Note: Check timing contact swinger spring tension and refine if necessary.

3.04 Timing Contact Mechanism (Later Design)

TIMING CONTACT

(1) Requirement

With unit in the stop position, there should be a gap between contact points

Min 0.008 inch---Max 0.011 inch

(2) Requirement

With the cam follower on the low parts of the cam, and the clearance taken up between the plunger and the cam follower, there should be some clearance between plunger and contact swinger.

To Adjust

Loosen the two posts holding the timing contact bracket to friction tightness. Position the bracket in order to meet (1) and (2) Requirements. Tighten the posts and recheck the adjustment.

Note: The TIMING CAM FOLLOWER SPRING (3.05) adjustment should be made before the TIMING CONTACT adjustment. If available, use a signal checking device to refine the TIMING CONTACT adjustment.

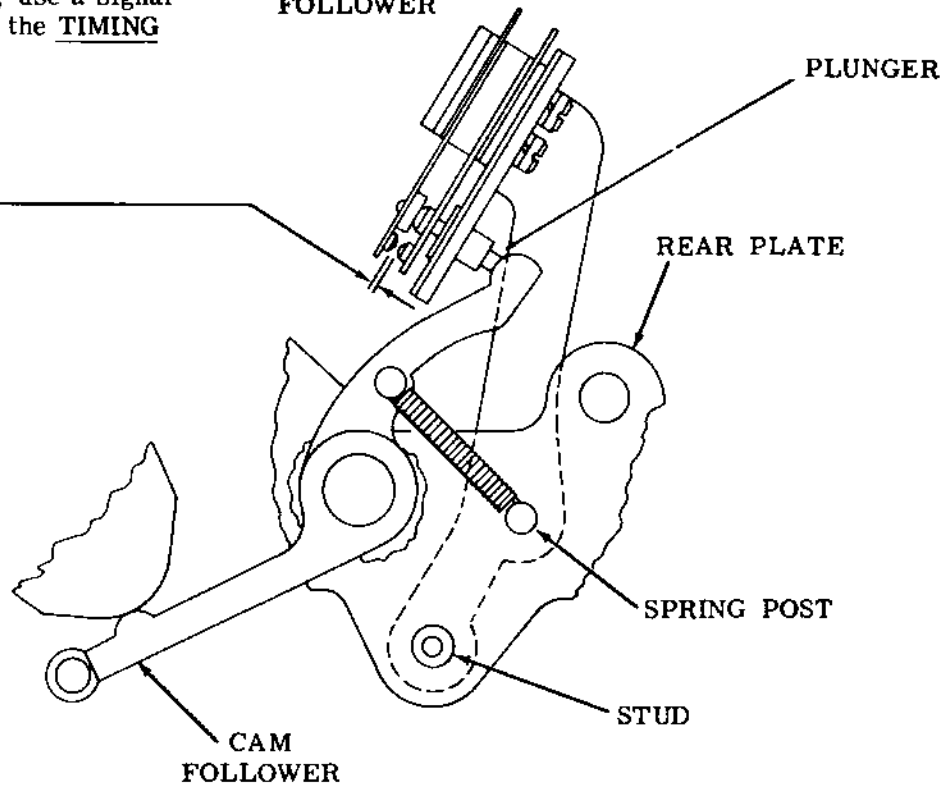
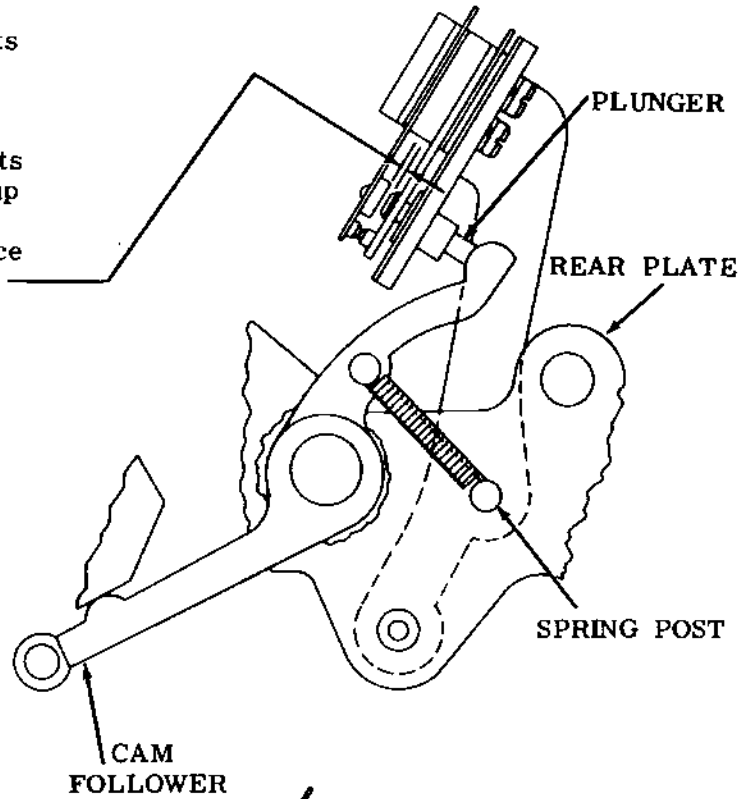



## 3.05 Timing Contact Mechanism (Later Design) (continued)

TIMING CAM FOLLOWER SPRING**To Check**

Timing contact assembly must be moved out of contact with the cam follower and spring post tightened to check this requirement and TIMING CONTACT SWINGER SPRING (3.06) adjustment.

**Requirement**

With the signal generator in the latched position, apply the pull end of scale to the cam follower

— Min 6 oz---Max 9 oz  
to start cam follower moving.

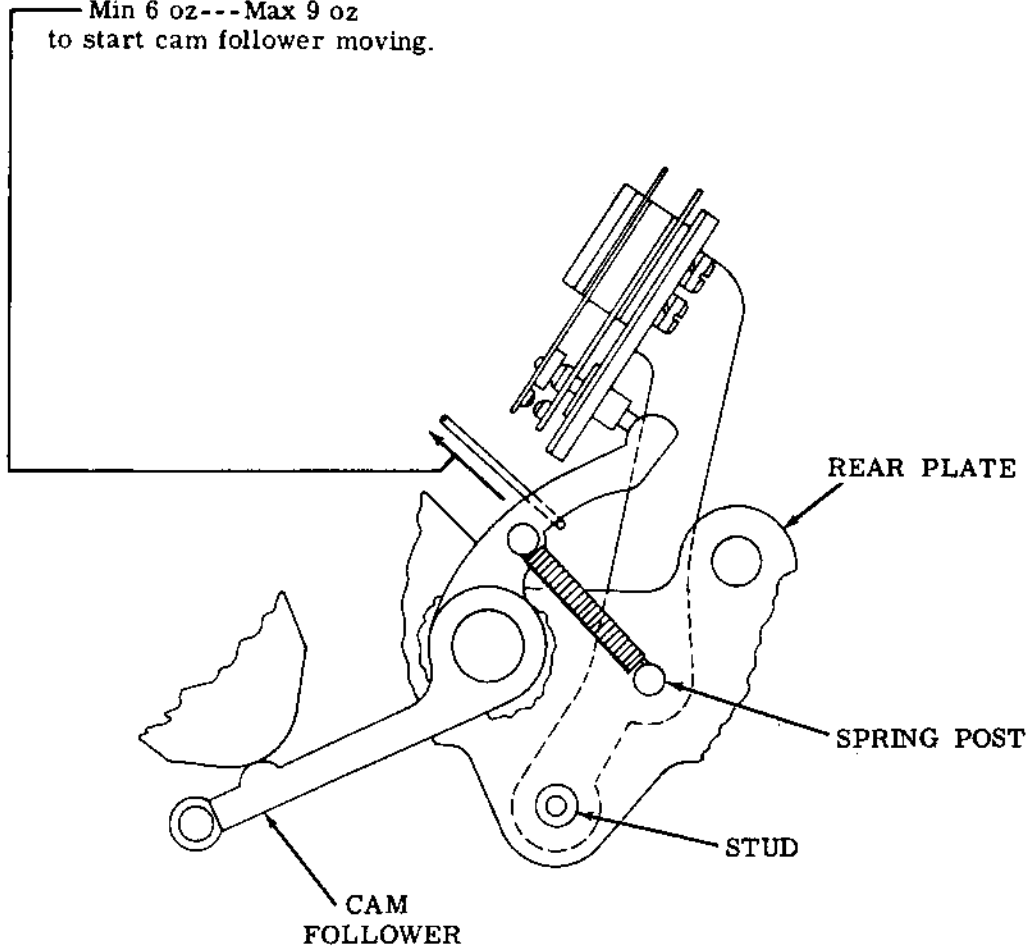

3.06 Timing Contact Mechanism (Later Design) (continued)

TIMING CONTACT SWINGER SPRING

(1) Requirement

Contact points should be in line and the head of the plunger should be centered in its hole in the spring as gauged by eye.

To Adjust

Position contact springs with screws friction tight. Tighten screws.

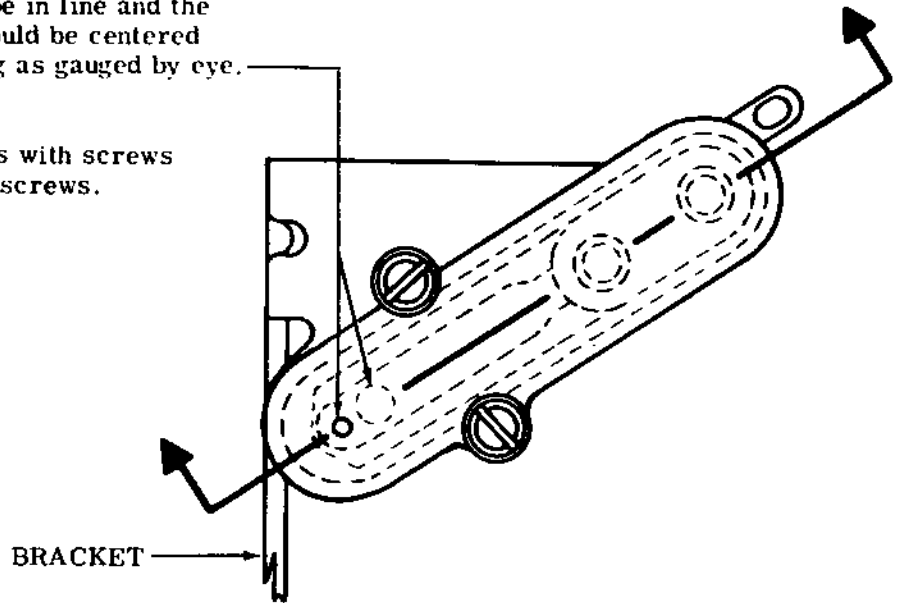

(3) Requirement

With contacts closed  
Min 3-1/2 oz---Max 4-1/2 oz  
to just open contacts.

To Adjust

Bend spring. Recheck timing contact adjustment.

Note: Timing contact assembly must be moved out of contact with the cam follower and spring post tightened to check requirement (3). Refer to TIMING CAM FOLLOWER SPRING (3.05) adjustment.

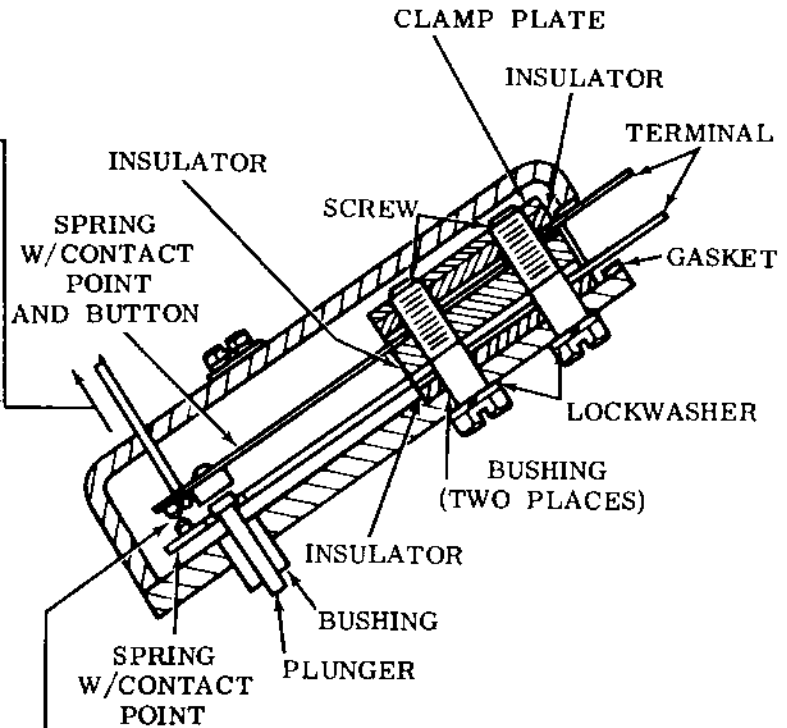

(2) Requirement

With plunger depressed flush with its bushing, contact gap should be  
Min 0.045 inch---Max 0.065 inch.

To Adjust

Bend spring.

## 3.07 Timing Contact Refinement

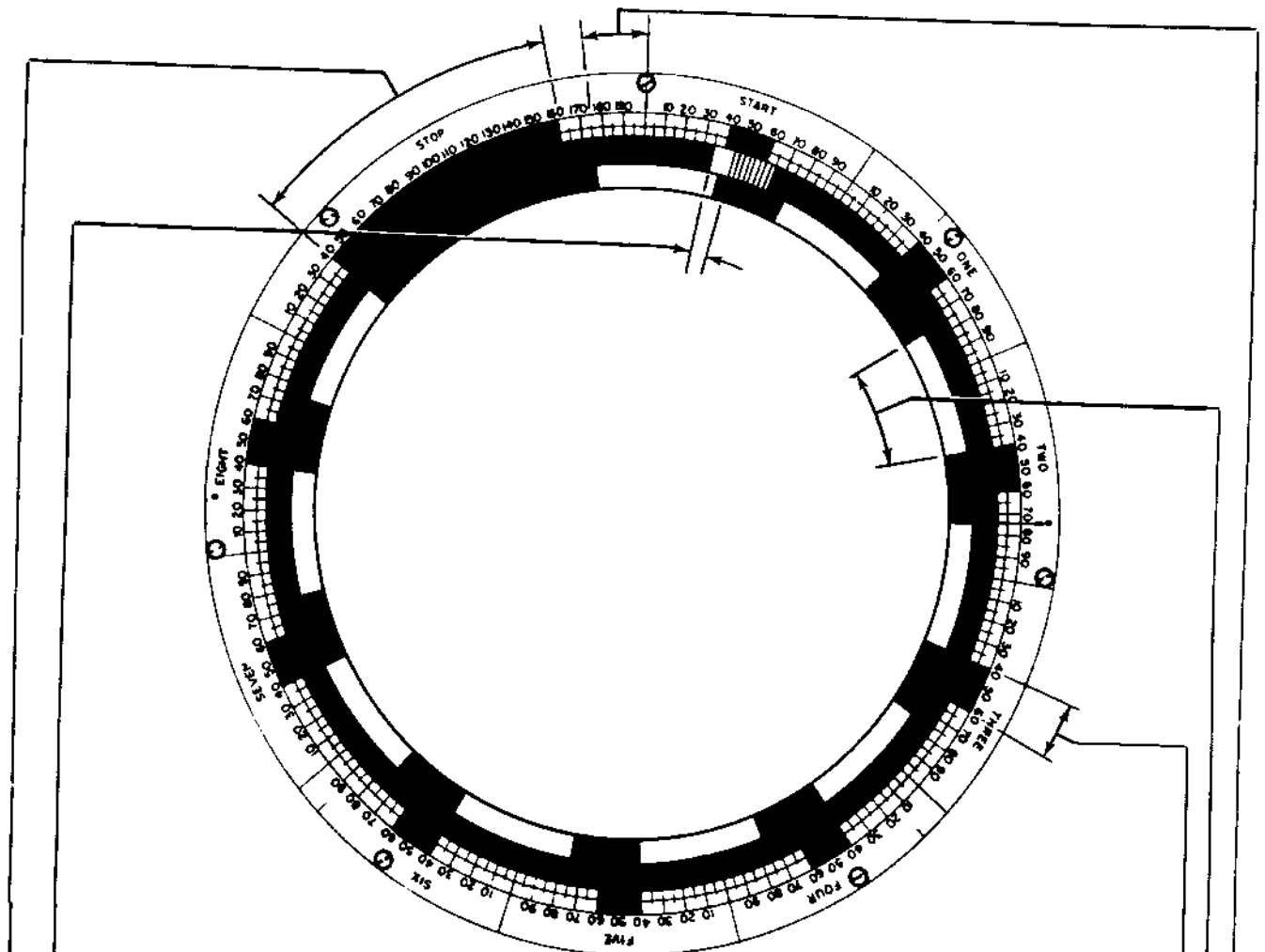
**TIMING CONTACT (STROBING)** (Using DXD test set, if available)

- (1) Zero the test set as described in Procedure (1) of 2.17.
- (2) The light image of the timing contacts should meet the following requirements for speeds up to and including 100 wpm.
  - (a) Open for a minimum of 20 divisions between the 25 division and 75 division points of each 100 division pulse.
  - (b) Open for a minimum of 120 divisions between the 25 division and 175 division points of the stop pulse.
  - (c) The close to open transitions should be in multiples of 100 divisions  $\pm 5$  divisions of the start pulse.
  - (d) There should be no contact break between the zero division point and the close to open transition point, and no contact break between the 75 division point and the 100 division point of each pulse. There should be no contact break between the 175 division point and the 200 division point of the stop pulse.

To Adjust

Check and refine, if necessary, the TIMING CONTACT (3.04) adjustment.

Note: The timing contacts should be open when the clutch is disengaged.

3.08 Auxiliary Contact Mechanism

CONTACT SWINGER SPRING

Requirement  
 Contacts closed  
 Min 2 oz---Max 3-1/2 oz  
 to just open contacts.

To Adjust  
 Use spring bender TP110455.

CONTACT GAP

Requirement  
 Clutch latched, cam follower on high  
 part of cam. Contact gap should be  
 Min 0.005 inch---Max 0.015 inch

To Adjust  
 Loosen posts that hold contact bracket.  
 Position bracket by use of screwdriver  
 placed between bracket upright and  
 rear plate.

CAM FOLLOWER SPRING

Requirement  
 Signal generator latched. Contact  
 spring held back  
 Min 6 oz  
 to start cam follower moving.

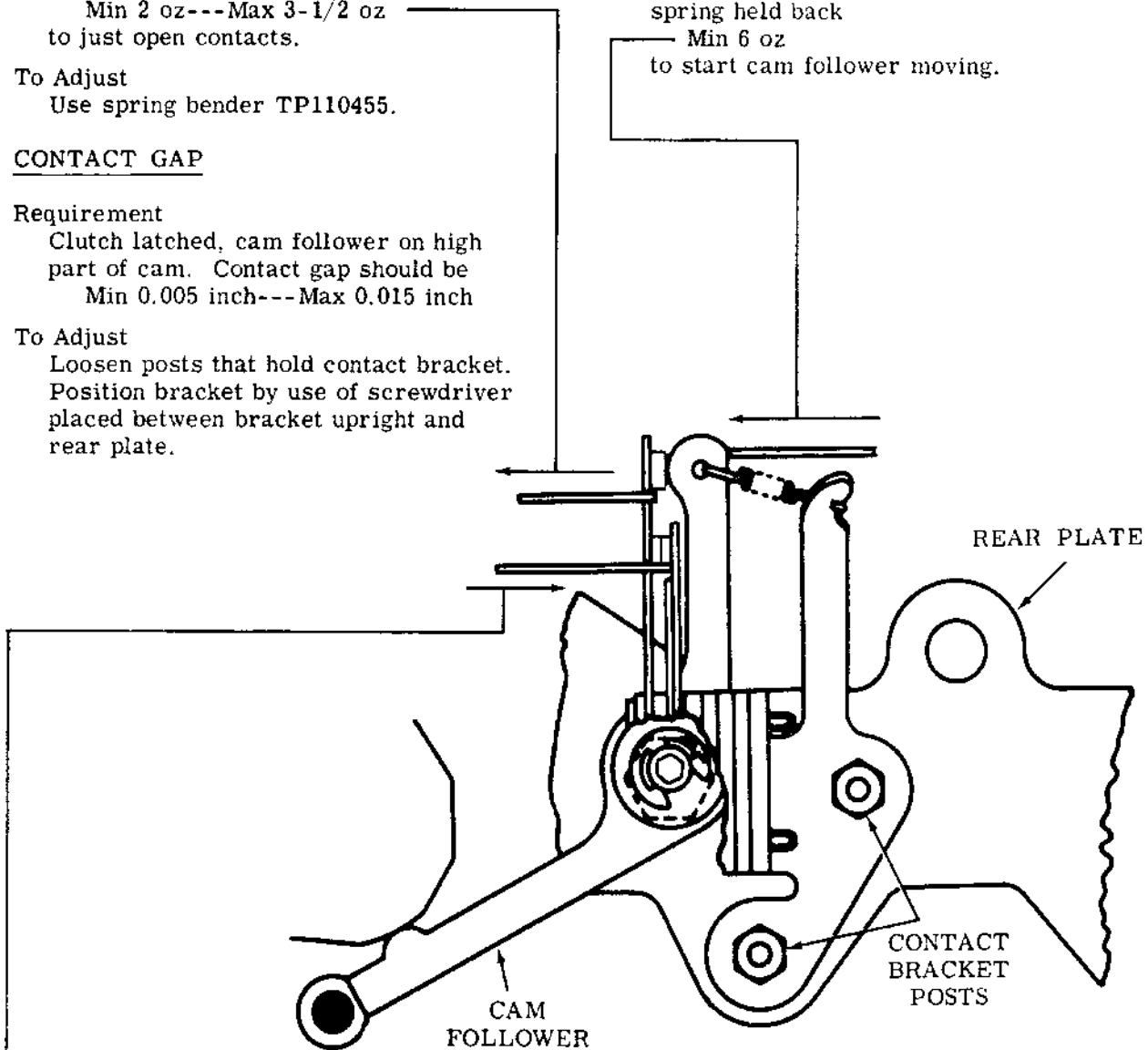

CONTACT STIFFENER SPRING

Requirement  
 Contact open  
 Min 5 oz---Max 8 oz  
 to move contact.

To Adjust  
 Remove contact assembly from unit by removing two studs securing it to rear  
 plate. Loosen two screws holding contact pile-up to contact assembly bracket  
 and bend contact using TP110455 spring bender until requirement is met.

Note 1: Check timing contact swinger spring tension and refine if necessary.

Note 2: See Par. 3.14 for AUXILIARY CONTACT REFINEMENT (STROBING).

3.09 Code Reading Contact Mechanism

Note 1: Adjustments on this page should be made with the contact assembly removed from the keyboard.

Note 2: Each adjustment should start with the contact pile-up farthest from the handle of the bending tool (Par. 3.10).

(A) BACKSTOP - NORMALLY CLOSED CONTACT

Requirement  
Normally closed contact leaf should be parallel to mounting plate and align with each other by 0.010 inch.

To Adjust  
Bend backstop.

(D) NORMALLY OPEN CONTACT GAP

Requirement  
Min 0.018 inch---Max 0.030 inch normally open gap.

To Adjust  
Bend backstop.

(C) CONTACT SWINGER SPRING

Requirement  
Min 30 grams---Max 40 grams to open the closed contact.

To Adjust  
Bend swinger.

(B) NORMALLY CLOSED CONTACT SPRING

Requirement  
Min 2 oz---Max 6 oz to move contact spring away from backstop. Hold swinger away from closed contact.

To Adjust  
Bend spring. To increase tension against backstop, bend backstop away from spring leaf and form leaf toward backstop, then reposition BACKSTOP-NORMALLY CLOSED CONTACT.

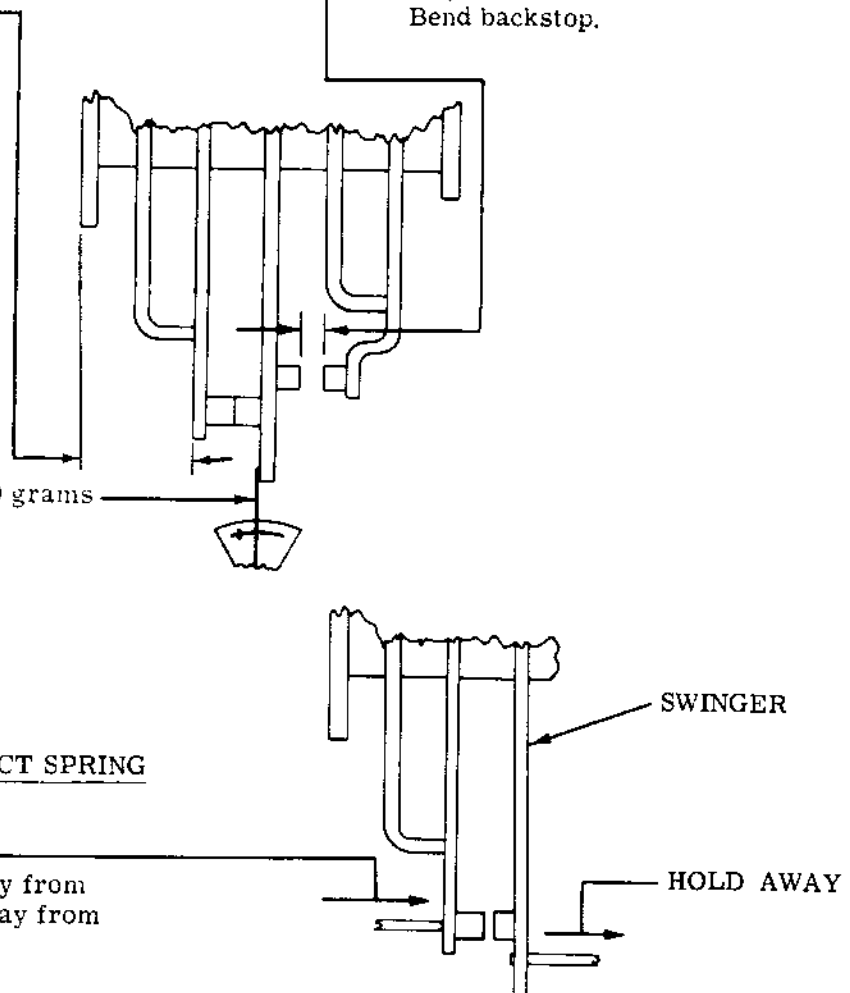

3.10 Code Reading Contact Mechanism (continued)

ADJUSTING CODE READING CONTACTS

Note: The contact assembly should be removed from the keyboard to perform the adjustments of Par. 3.09. It is not necessary to remove the wires from the assembly.

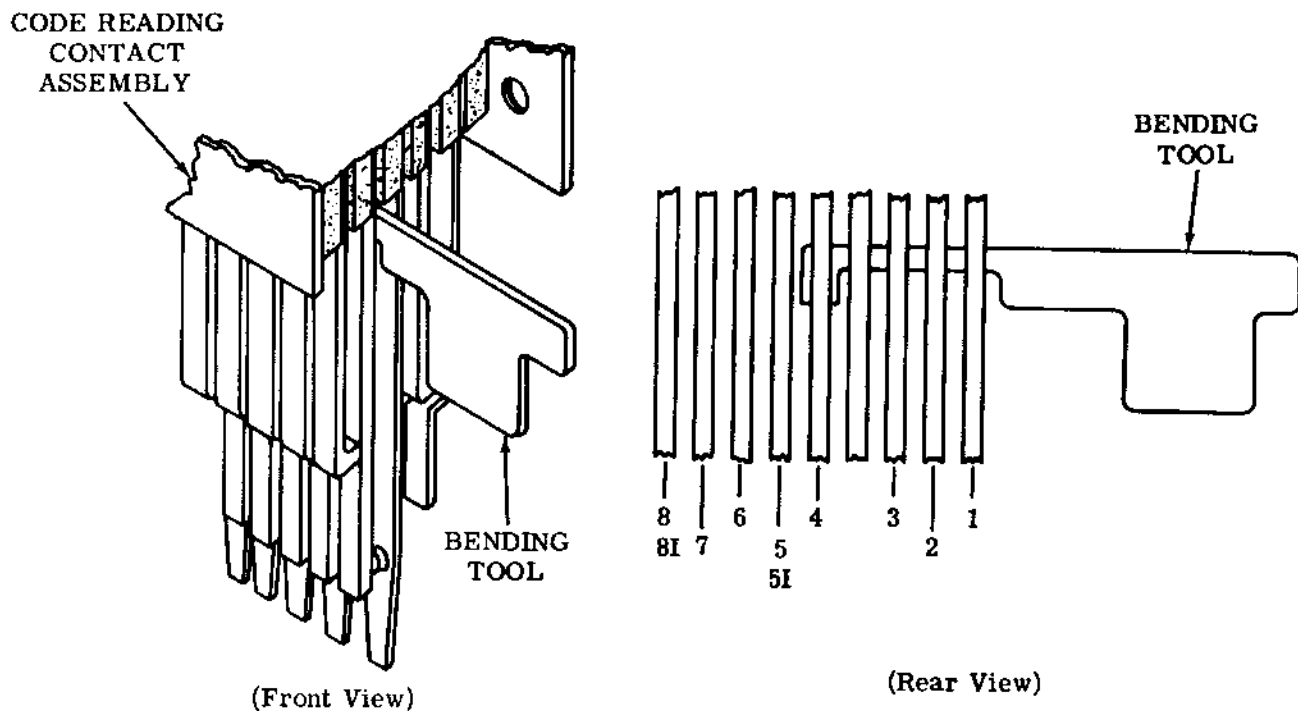

**Requirement**

Each adjustment should start with the contact pile-up farthest from the handle of the bending tool.

**To Adjust**

After adjusting contact pile-ups 4, 3, 2, and 1, insert the bending tool in the opposite side of the assembly and adjust contact pile-ups 5, 6, 7, and 8 in the order given.

3.11 Code Reading Contact Mechanism (continued)

Note: Perform (A), then install contact assembly on the keyboard for the remaining code reading contact adjustments.

(B) MARKING CONTACT GAP

Requirement  
With the clutch latched  
Min 0.005 inch--- Max 0.015 inch  
contact gap. Check outside levels only.

To Adjust  
Loosen four contact mounting bracket screws.  
Position contact adjustment mounting bracket.

**CAUTION: DO NOT APPLY FORCE TO CONTACT  
PILE-UP.**

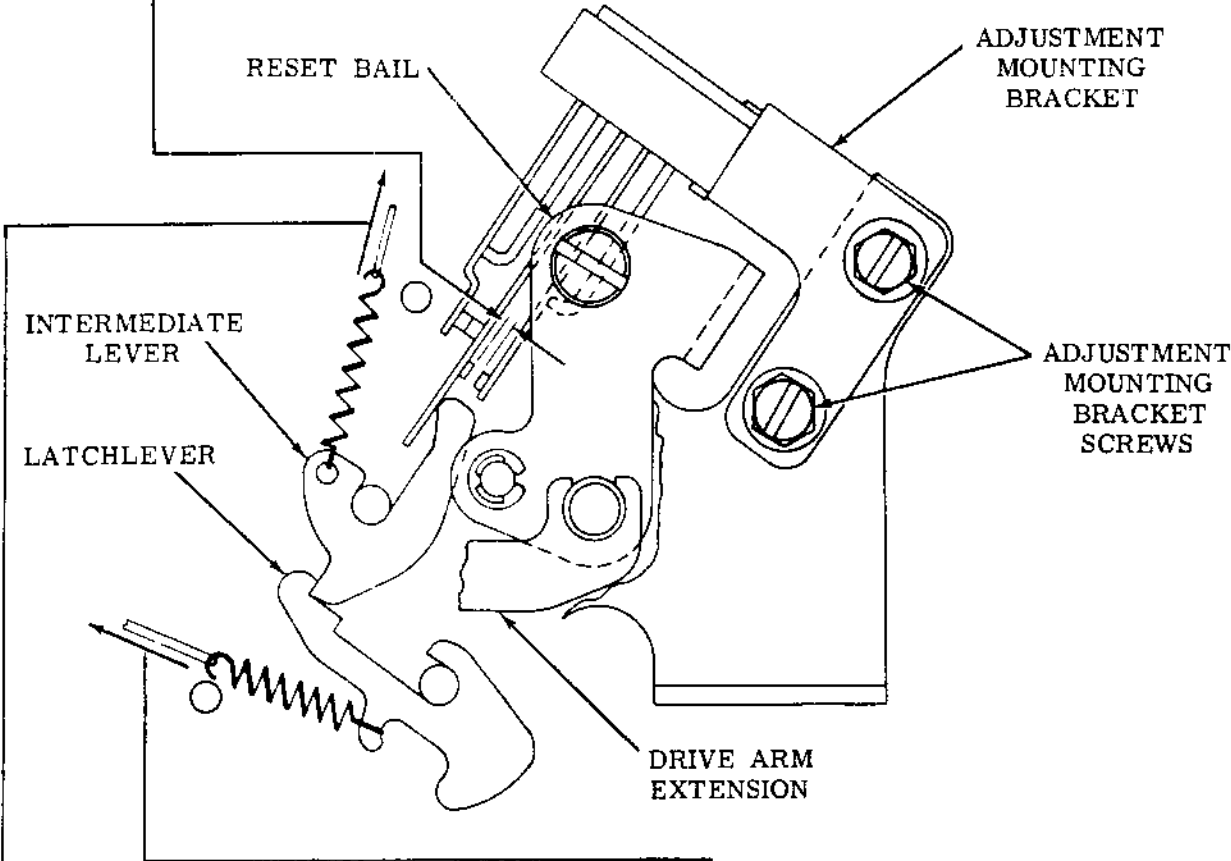

(C) INTERMEDIATE LEVER SPRING

Requirement  
With the clutch latched  
Min 1 oz---Max 2 oz  
to pull spring to installed length.

(A) LATCHLEVER SPRING

Requirement  
With the clutch latched  
Min 2 oz---Max 4 oz  
to pull spring to installed length.

3.12 Code Reading Contact Mechanism (continued)

RESET BAIL

To Check

Clutch unlatched and keyboard eccentric drive arm extension to extreme left.

Requirement

Gap between any one latch and its intermediate lever should be  
Min 0.005---Max 0.030 inch

To Adjust

Loosen four mounting plate screws and position assembly.

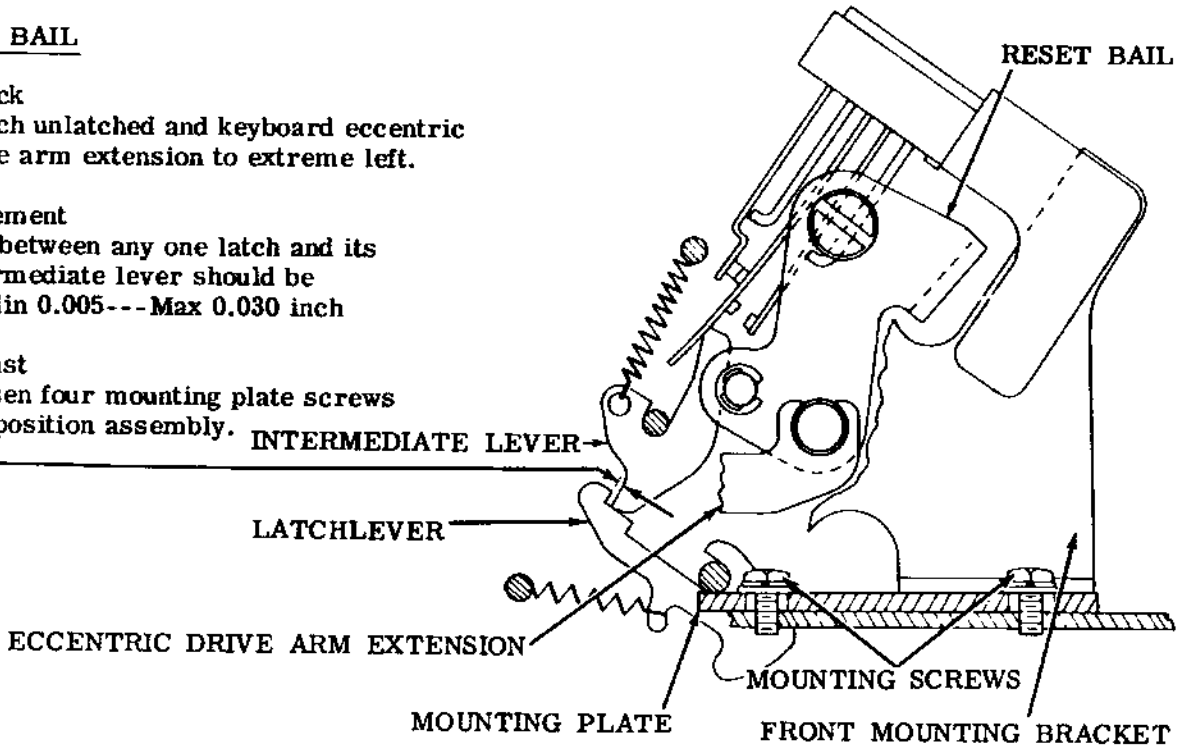

RESET BAIL SPRING

Requirement

Clutch latched  
Min 1/2 oz---Max 1-1/2 oz  
to pull spring to installed length.

DRIVE ARM EXTENSION SPRING

Requirement

Clutch latched  
Min 4 oz---Max 5 oz  
to pull spring to installed length.

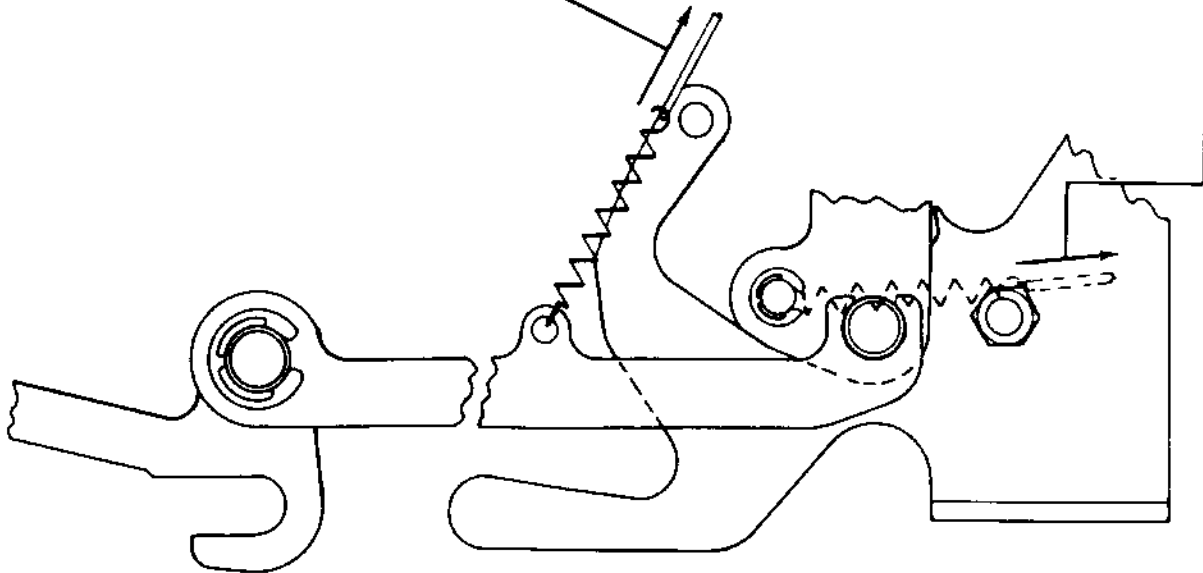



## 3.13 Code Reading Contact Mechanism (continued)

Note 1: The following tests should be performed using a DXD test set, if available, after the contact assembly has been installed and all adjustments have been made.

Note 2: Minimum signal lengths apply to time between latest start and earliest end of all contact traces.

CODE READING CONTACT REFINEMENT (STROBING)

(1) Requirement

Zero the strobe unit (DXD) as follows:

- (a) Connect strobe neon trace to code reading contact no. 1. Send rubout combination from keyboard. Note latest point at which trace begins.
- (b) Repeat step (a) for all code reading contacts.
- (c) Choose trace that starts latest and set "start-zero" mark of strobe scale to this point.
- (d) Record earliest end of neon traces for future adjustment references.

(2) Requirement

Connect neon trace lamp to marking contact (contact that is normally open when keyboard is idle) of code reading contact assembly.

- (a) Send rubout combination from keyboard.
- (b) Combined code reading contact traces should have minimum signal length of 500 divisions (length between latest start and earliest end) and all bounce should end within 20 divisions of latest start of a contact trace. See Par. 3.14 for figure of strobe trace.

Repeat (2) Requirement for each code reading contact.

To Adjust

Refine BACKSTOP-NORMALLY CLOSED CONTACT (3.09) adjustment.

Refine NORMALLY CLOSED CONTACT SPRING (3.09) and CONTACT SWINGER SPRING (3.09) adjustments if there is excessive bounce.

3.14 Code Reading Contact Mechanism (continued)  
 Auxiliary Contact Mechanism (continued)

AUXILIARY CONTACT REFINEMENT (STROBING)

Note 1: The following tests should be performed using a DXD test set, if available, after the contact assembly has been installed and all adjustments have been made.

Note 2: Minimum signal lengths apply to time between latest start and earliest end of all contact traces.

Note 3: Zero the strobe unit (DXD) as explained in (1) Requirement of Par. 3.13.

(1) Requirement  
 Connect strobe neon trace to auxiliary contacts.

(2) Requirement  
 Send rubout combination from keyboard.

(3) Requirement  
 End of neon trace should occur at a minimum of 22 divisions before earliest end of code read contact traces (including any bounce). Start of trace should begin at a minimum of 143 divisions after the strobe "start-zero" mark. The pulse must be at least 250 divisions long.

To Adjust  
 Refine CONTACT GAP (3.08) adjustment.

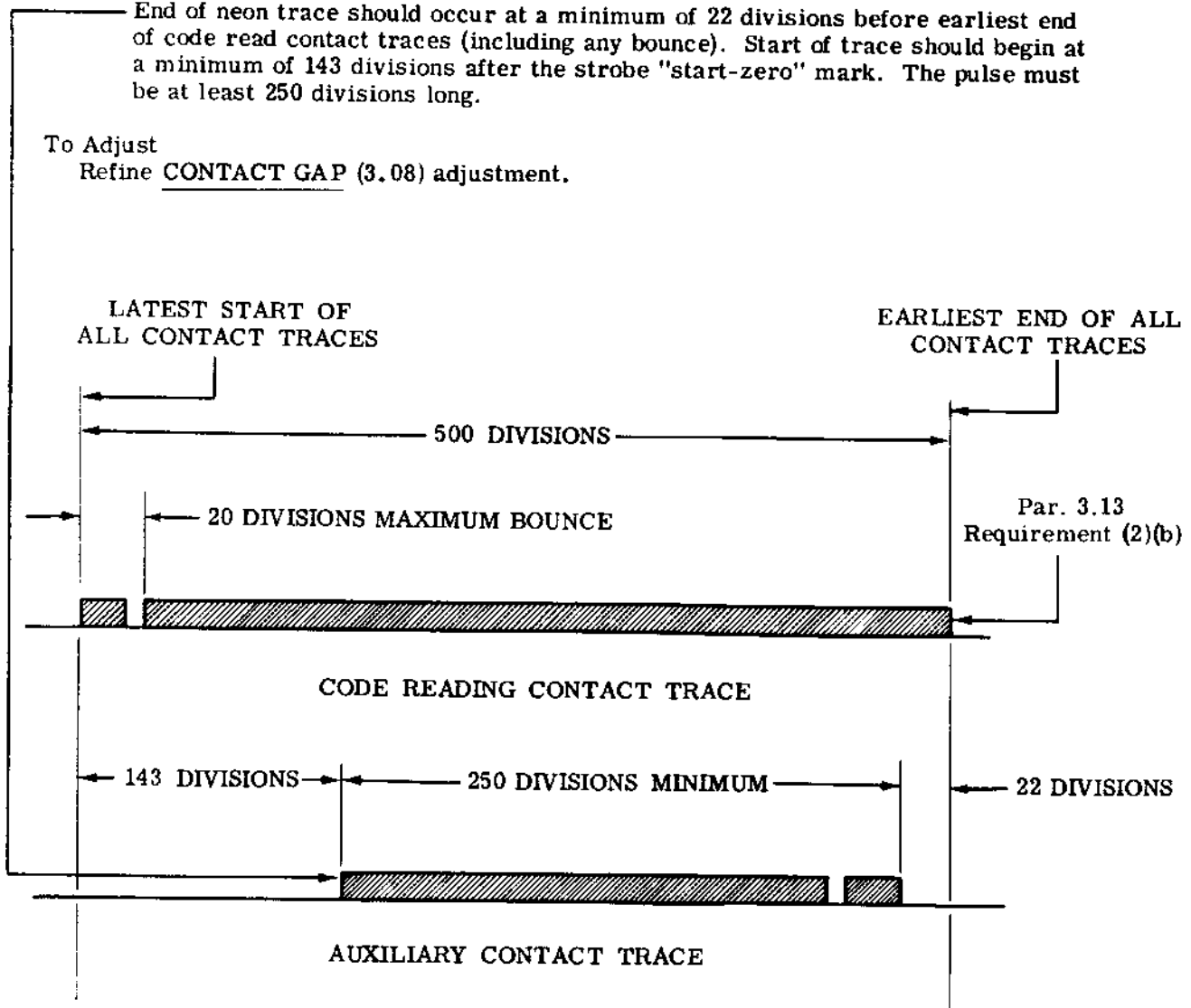

3.15 Strobing Requirement

Note 1: The following tests should be performed using a DXD test set, if available.

Note 2: For units equipped with signal regenerators, remove regenerator circuit card before applying test set probes to signal contacts.

SIGNAL GENERATOR CONTACTS

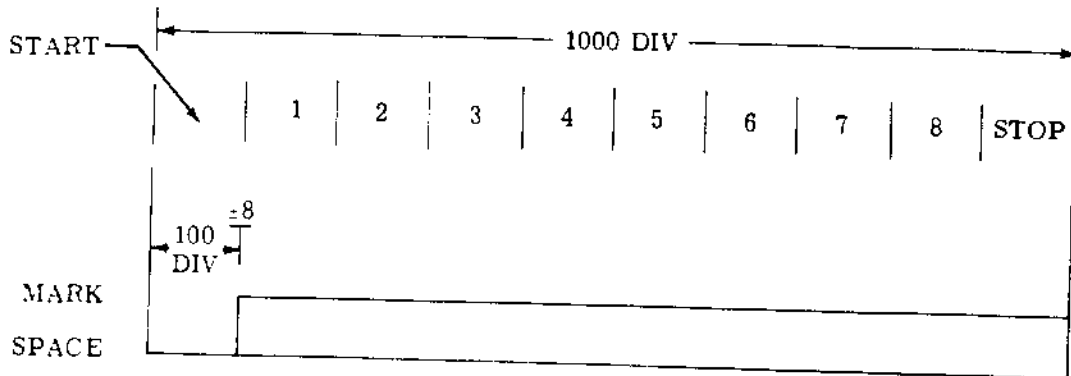

CODE READING AND TIMING CONTACTS

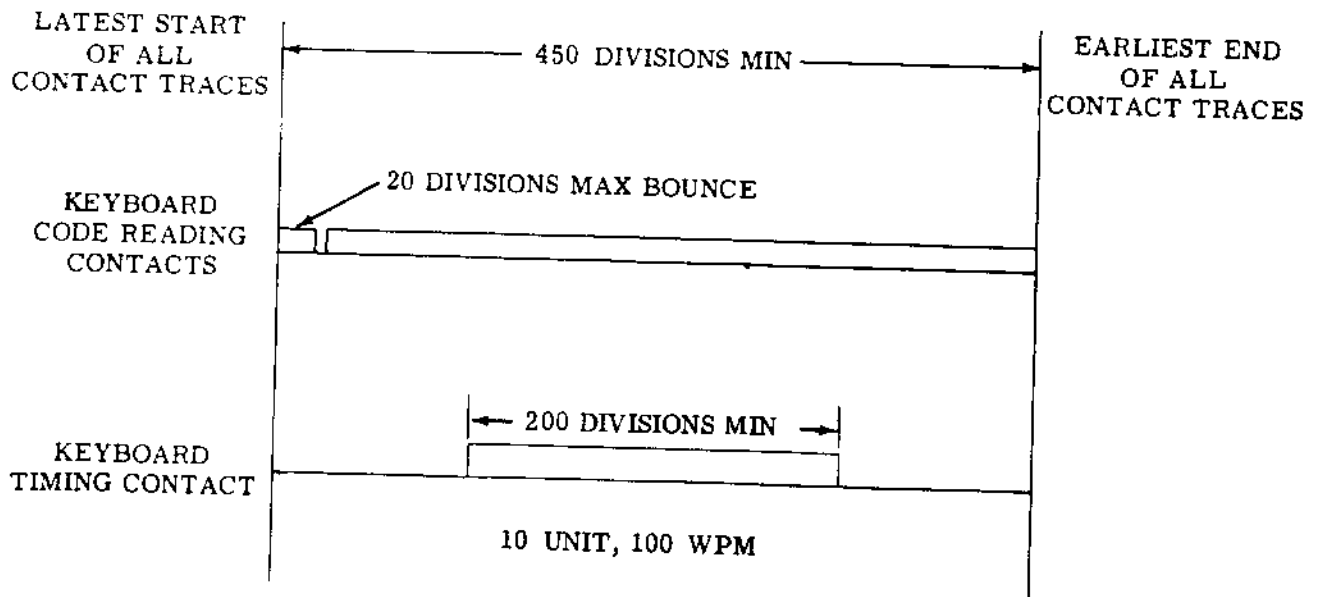

**CAUTION:** APPLYING OPERATING VOLTAGE OF SIGNAL DISTORTION TEST SET DIRECTLY TO GOLD-PLATED SIGNAL CONTACTS MAY MAKE THEM UNSUITABLE FOR LOW-VOLTAGE APPLICATIONS. SEE PAR. 2.19 FOR SERVICING INSTRUCTIONS.

3.16 Local Backspace Mechanism

BACKSPACE TRANSFER BAIL ADJUSTING LEVER

Requirement

Downward pressure on backspace key  
 Min 16 oz---Max 28 oz  
 to operate backspace lever.

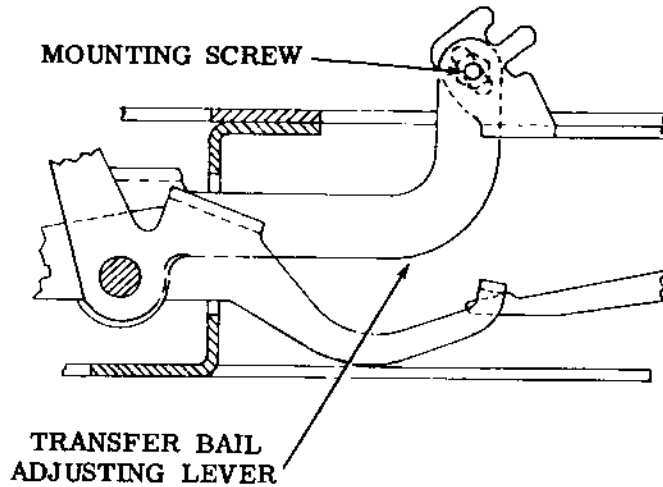

To Adjust

Position transfer bail adjusting lever with its mounting screw loosened. If unit is forward spacing, the adjusting lever must be raised until proper backspacing is accomplished.

Note 1: This adjustment may require remaking when a different typing unit is used.

Note 2: The camming bail should return to its unoperated position when the keylever is released. Refine adjustment if necessary.

BACKSPACE TRIP LINK HORIZONTAL SPRING

Requirement

Unhook spring  
 Min 1-3/4 oz---Max 3 oz  
 to pull spring to installed length.

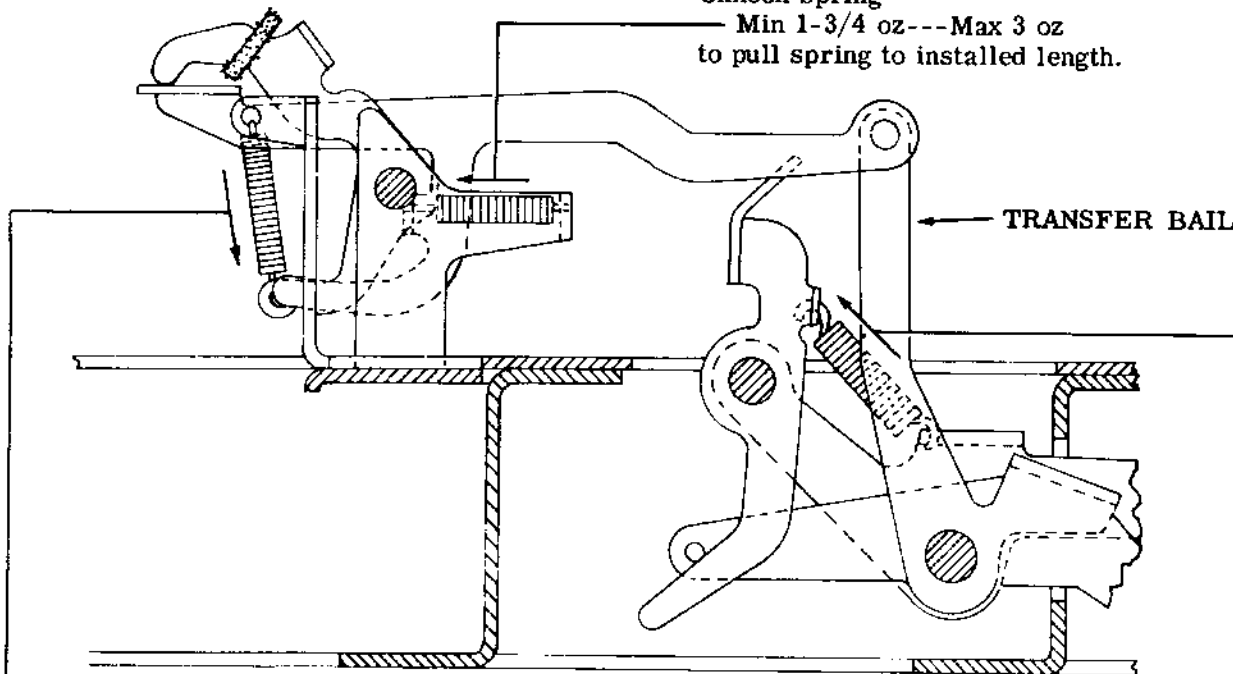

BACKSPACE TRIP LINK VERTICAL SPRING

Requirement

Unhook spring  
 Min 1-1/2 oz---Max 3 oz  
 to pull spring to installed length.

BACKSPACE TRANSFER BAIL SPRING

Requirement

Unhook spring  
 Min 1/2 oz---Max 1 oz  
 to pull spring to installed length.

3.17 Receive-Break Switch Mechanism

RECEIVE-BREAK SWITCH

To Check

Keyboard lock plunger in downward position. Function bail latched.

Requirement

The bail should operate the contact pile-up with some overtravel.

To Adjust

Loosen locknut on adjusting screw and position screw. Recheck for overtravel.

RECEIVE-BREAK SWITCH TENSION

Requirement

Normally open contacts should close and normally closed contacts should open  
Min 10 oz---Max 16 oz

To Adjust

Bend leaves carefully to meet requirements.

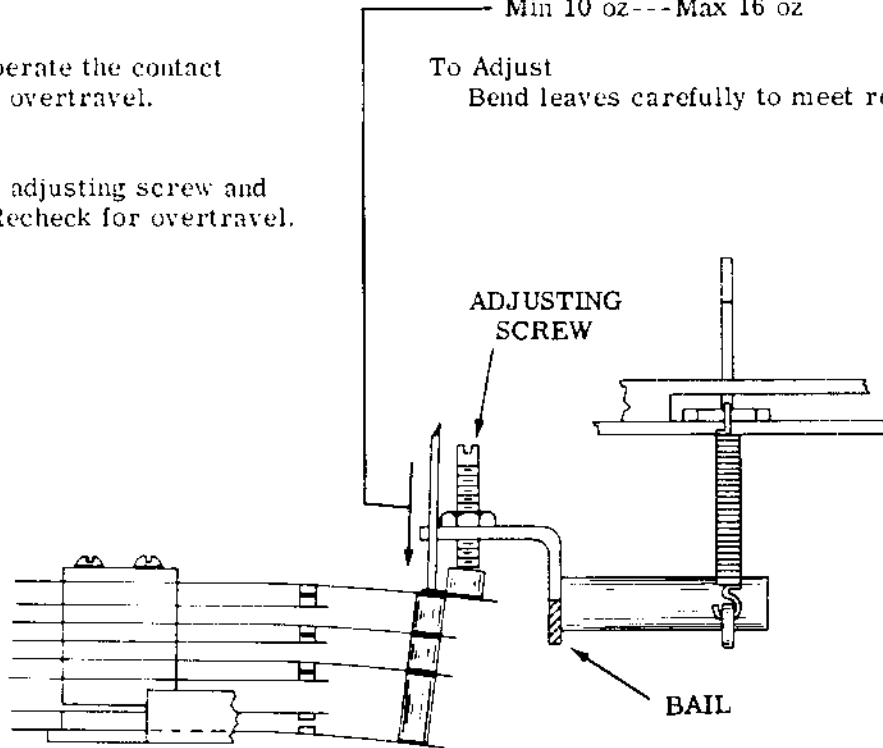

3.18 Keyboard Universal Contact Mechanism

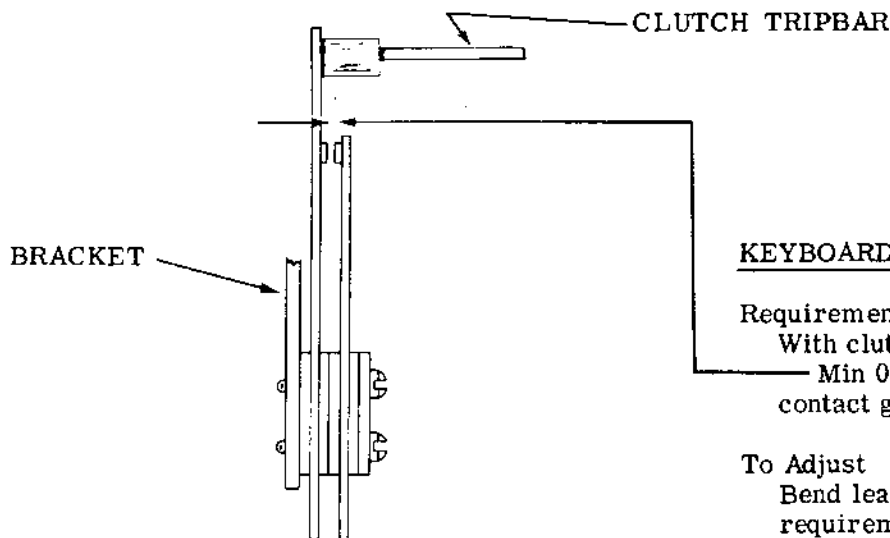

KEYBOARD UNIVERSAL CONTACT

Requirement

With clutch latched  
Min 0.010 inch---Max 0.020 inch  
contact gap.

To Adjust

Bend leaves carefully to meet  
requirement.

3.19 Codebar Arrangement for Even Parity

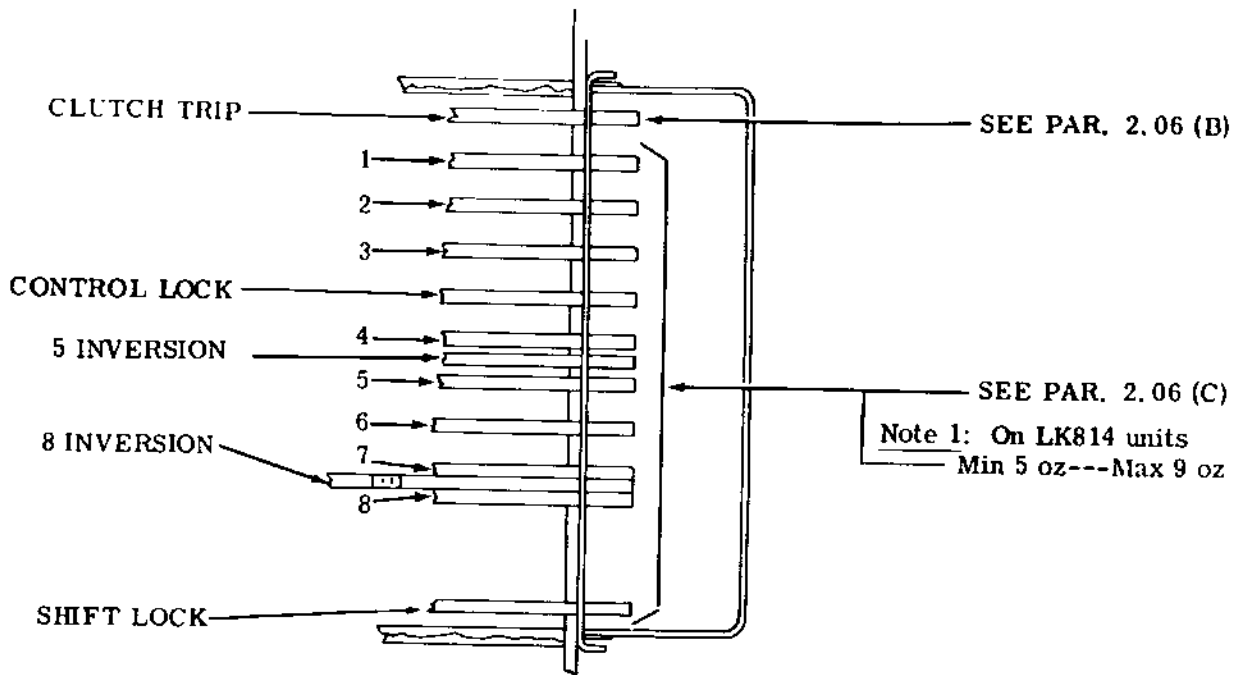

NO. 5, 8 INVERSION CODE BAR SPRINGS

Requirement

Codebar in latched position.

Unhook spring at guide

Min 6 oz---Max 8 oz  
to pull to installed length.

Note 2: On LK814 units

Min 7-1/2 oz---Max 9-1/2 oz

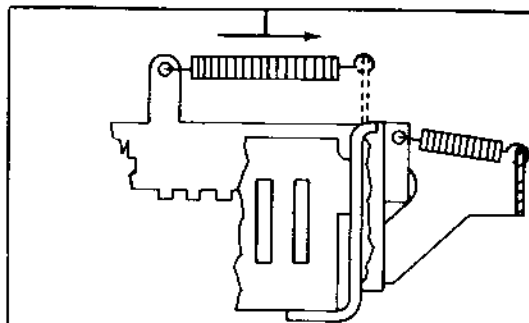

TRANSITION BAR SPRING

Requirement

Unhook spring at guide

Min 1/2 oz---Max 1-1/2 oz  
to pull to installed length.

3.20 Local Single Line Feed Mechanism

LOCAL SINGLE LINE FEED TRIP LINK VERTICAL SPRING

Requirement

Unhook spring  
Min 1-1/2 oz---Max 2-1/2 oz  
to pull spring to installed length.

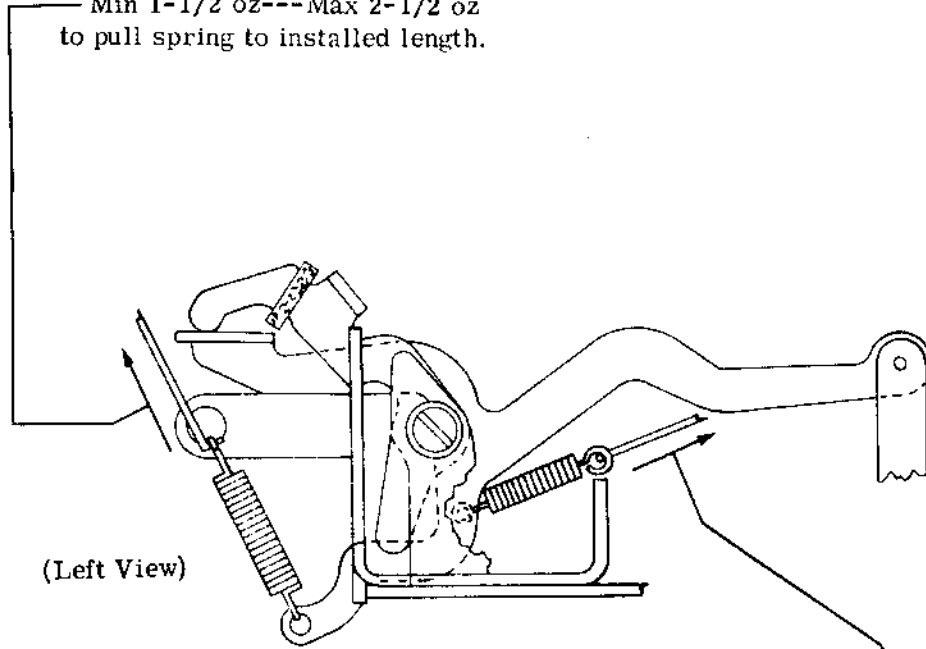

LOCAL SINGLE LINE FEED TRIP LINK HORIZONTAL REAR SPRING

Requirement

Unhook spring  
Min 1-1/2 oz---Max 3-1/2 oz  
to pull spring to installed length.

LOCAL SINGLE LINE FEED TRIP LINK HORIZONTAL FRONT SPRING

Requirement

Unhook spring  
Min 1-1/2 oz---Max 2-1/2 oz  
to pull spring to installed length.

3.21 Universal Keyboard Switch Mechanism

Note: Suitable arc suppression should be provided when warranted.

KEYBOARD SWITCH (HORIZONTAL)

(1) Requirement

Align contact assembly, guide, and code lever assembly. There should be

Min some---Max 0.020 inch clearance between the right edge of the contact swinger insulator and the extension of the code lever assembly in the unoperated position.

To Adjust

Loosen screw holding the contact assembly to the retainer bars and adjust. Tighten screw.

(2) Requirement

Clearance between the contact assembly spring and the keyboard wedge retainer should be

Min 0.062 inch

To Adjust

Bend the retainer bar if necessary.

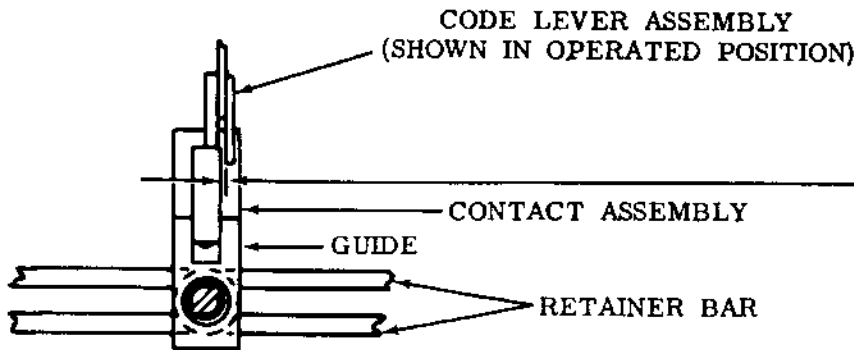



## 3.22 Universal Keyboard Switch Mechanism (continued)

KEYLEVER SWITCH (VERTICAL)

## (1) Requirement

With unit in stop position and keylever depressed to a point where clutch engages, center and lower contact should just close or have a maximum gap of 0.008 inch.

## (2) Requirement

For keylevers which do not cause clutch engagements, and with keylever unoperated, tip of code lever lobe should overlap contact swinger by Min some---Max 0.020 inch

## To Adjust

Loosen two screws which fasten two brackets on the two studs and position complete mounting assembly.

Note: When switch is used, the keytop pressure may be increased up to 2 oz over the normal requirement.

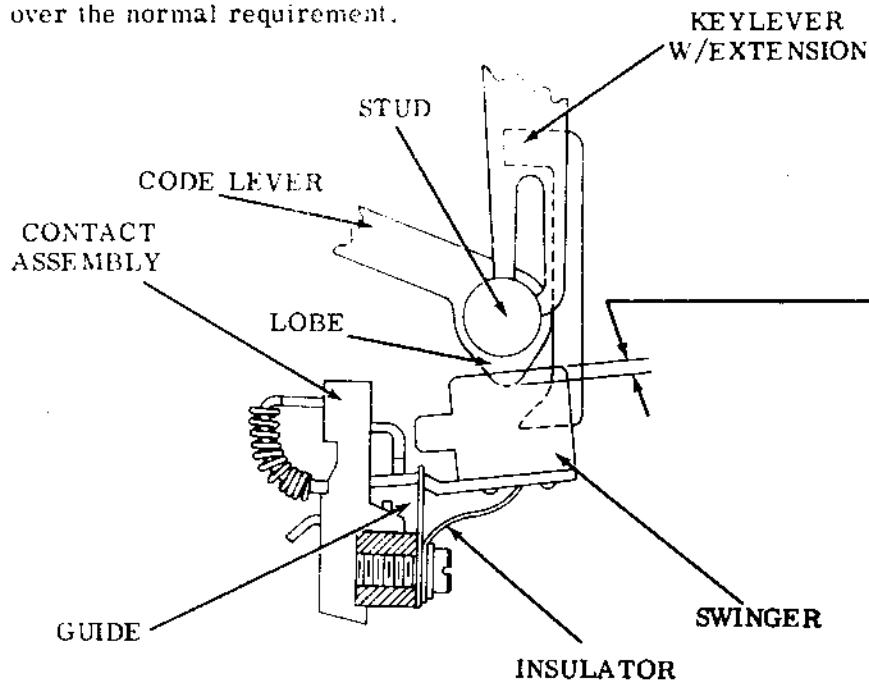

3.23 Local Reverse Line Feed Mechanism

LOCAL REVERSE LINE FEED TRIP LINK  
VERTICAL SPRING

**Requirement**

**Typing unit removed.**

**Min 1-1/2 ozs---Max 2-1/2 ozs  
To pull spring to installed length.**

LOCAL REVERSE LINE FEED TRIP  
LINK HORIZONTAL SPRING

**Requirement**

**Typing unit removed.**

**Min 1-1/2 ozs---Max 3-1/2 ozs  
To pull spring to installed length.**

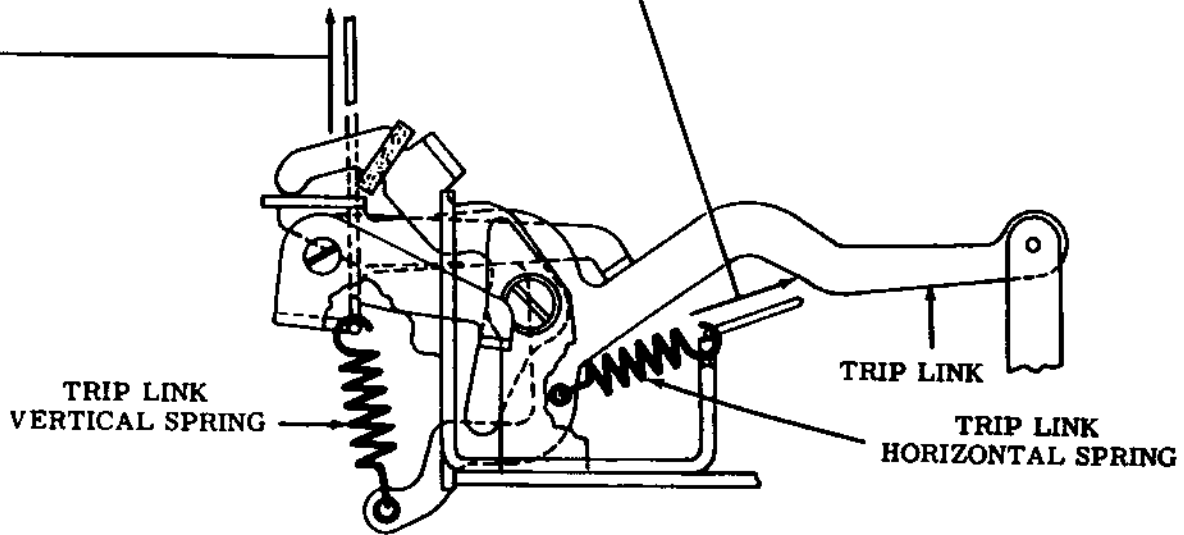

35 CABINETS FOR KEYBOARD SEND-RECEIVE AND RECEIVE-ONLY SETS

ADJUSTMENTS

CONTENTS	PAGE	CONTENTS	PAGE
1. GENERAL . . . . .	1	Upper cover clearance (latched) . . . . .	4
2. ADJUSTMENTS . . . . .	2	Upper cover position (front to rear) . . . . .	4
Bubble latch plate (final) . . . . .	11	Window . . . . .	19
Bubble latch plate (preliminary) . . . . .	7	Window door hinge mounts . . . . .	18
Bubble position front and rear (final) . . . . .	11	Window (final) . . . . .	11
Bubble position front and rear (preliminary) . . . . .	7	Window (preliminary) . . . . .	7
Call control unit height . . . . .	12		
Call control unit mounting bracket . . . . .	12	1. GENERAL	
Carriage return, line feed, and break lever (receive-only unit) . . . . .	18	1.01 This section is reissued to include re- cent engineering changes and additions. Arrows in the margins indicate changes and additions.	
Cleaning cabinets . . . . .	13	1.02 The adjustments in this section are ar- ranged in a sequence that should be fol- lowed if a complete readjustment is undertaken. A complete adjusting procedure should be read before attempting to make the adjustment. After an adjustment is completed, be sure to tighten any nuts or screws that may have been loosened, unless otherwise instructed.	
Control panel . . . . .	10	1.03 The adjusting illustrations indicate toler- ances, positions of moving parts, spring tensions and the angle at which scales should be applied. The tools required to make adjustments and check spring tensions are not supplied with the equipment, but are listed in another section. Springs which do not meet the requirements, and for which there are no adjusting procedures, should be discarded and replaced by new springs.	
Copylamps . . . . .	19	1.04 Where adjustment instructions call for removal of components, assemblies, sub- assemblies or parts, all adjustments which the removal of these parts might facilitate should be made before the parts are replaced or as the equipment is reassembled. When a part mounted on shims is removed, the number of shims and their location should be noted so that the identical pile-up can be made when the part is replaced.	
Copylight bracket and end-of-line lamp . . . . .	5	1.05 References made to left or right, up or down, front or rear, etc apply to the unit in its normal operating position as viewed from the operator's position in front of the unit.	
Counterbalance arm . . . . .	5		
Cradle front to rear - earlier design . . . . .	8		
Cradle front to rear - later design . . . . .	9		
Cradle height (final) - earlier design . . . . .	8		
Cradle height (final) - later design . . . . .	9		
Cradle height (preliminary) - earlier design . . . . .	8		
Cradle height (preliminary) - later design . . . . .	9		
Framework mounted on backplate . . . . .	15		
Front height of lower cover - later design . . . . .	9		
Hinge mounts . . . . .	15		
Keytop cover (receive-only unit) . . . . .	16		
Keytop guide and cover (send- receive unit) . . . . .	17		
Keytop guideplate hood (send-receive unit) . . . . .	16		
Latch . . . . .	4		
Line guide copyholder . . . . .	6		
Lower cover latch . . . . .	13		
Lower door hinge mounts . . . . .	18		
Lower door latches . . . . .	18		
Lower panel pivot post . . . . .	14		
Opening and closing of cover . . . . .	2, 3		
Paper and form guide . . . . .	11		
Paper guide . . . . .	19		
Power switch (receive-only unit) . . . . .	17		
Upper apparatus mounting rack bracket (floor standing cabinets only - old style only) . . . . .	12		

SECTION 574-229-700TC

2. ADJUSTMENTS

2.01 Opening and Closing of Cover

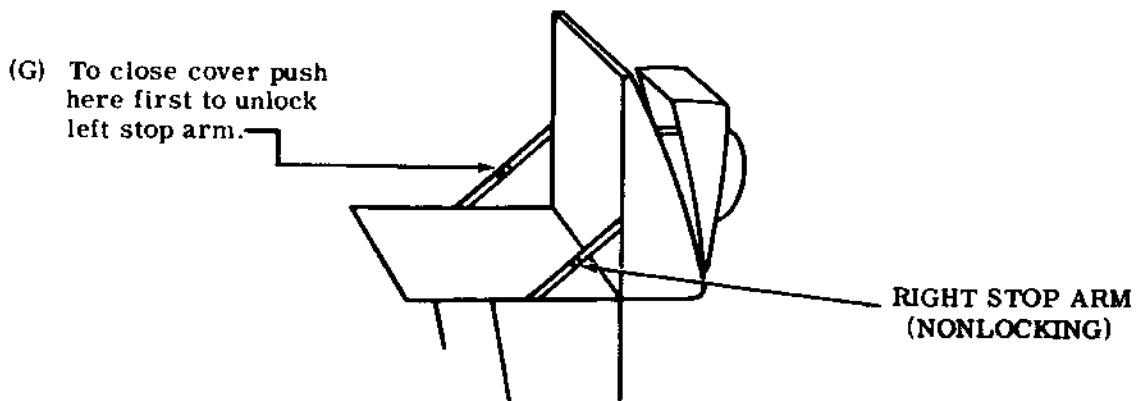
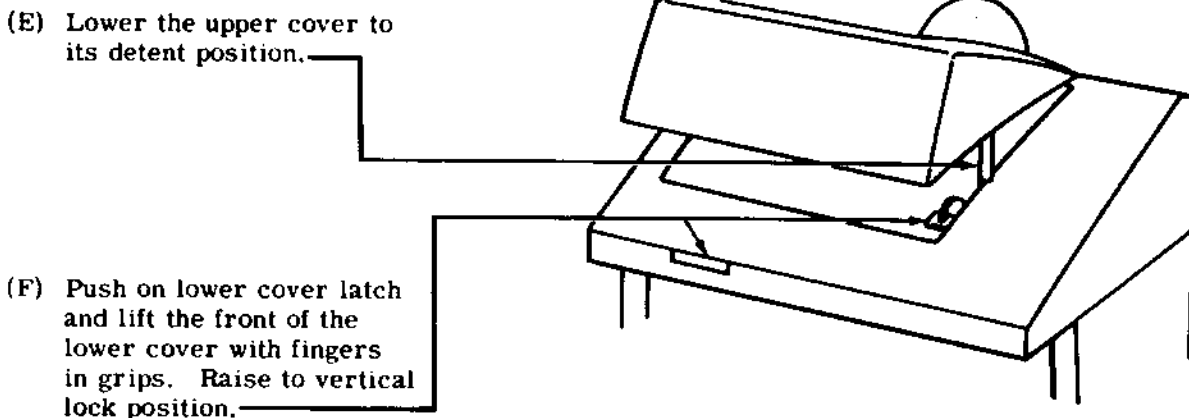
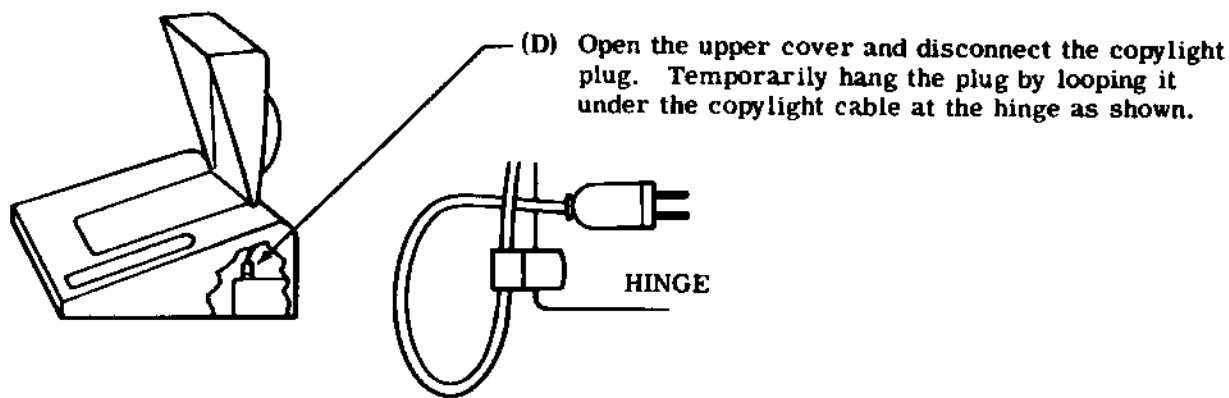
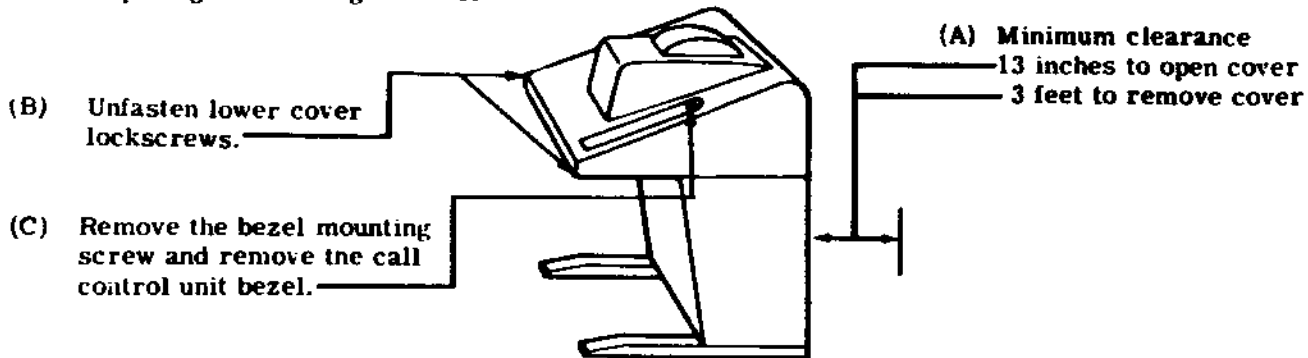

2.02 Opening and Closing of Cover (continued)

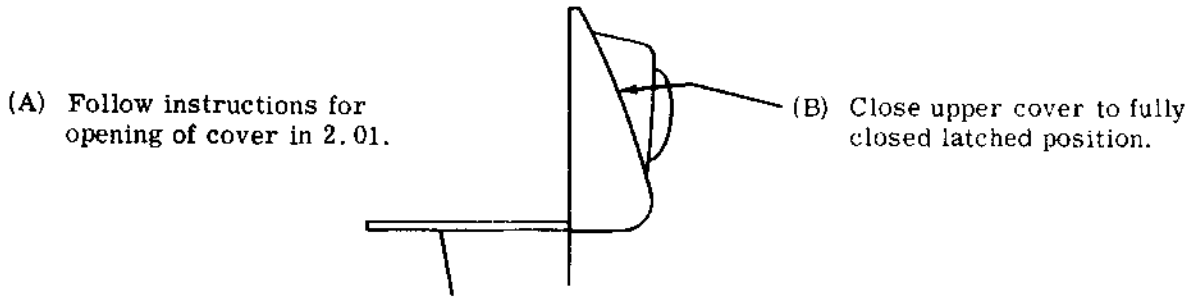

INSIDE BACK OF COVER IN OPEN POSITION  
(VIEW LOOKING STRAIGHT DOWN)

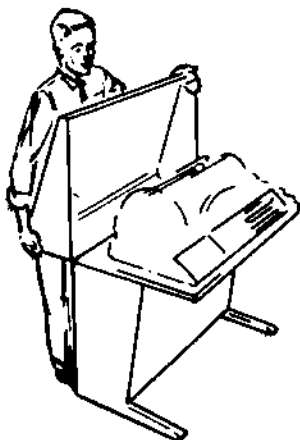
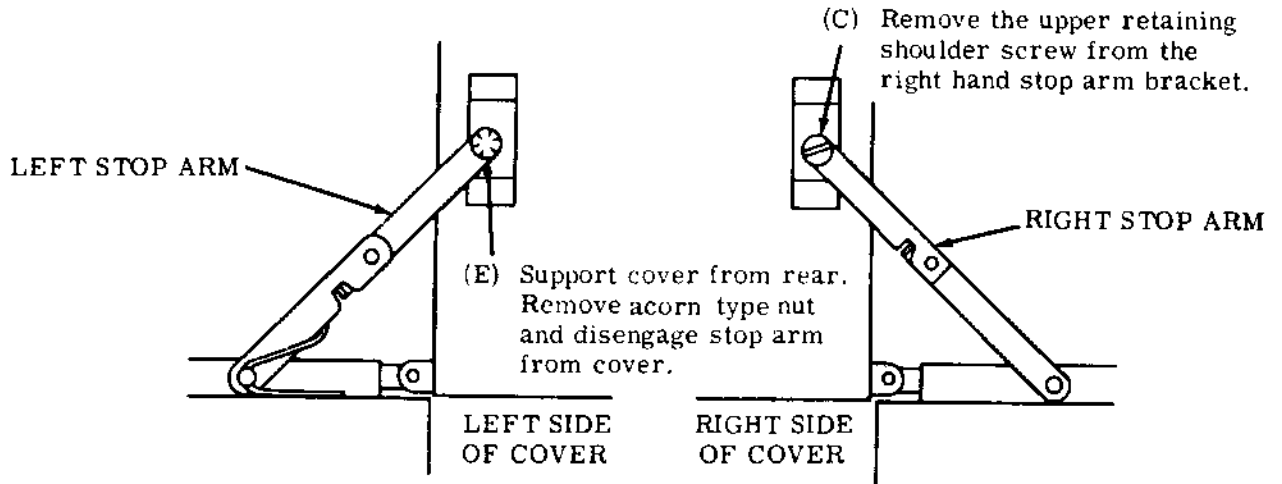
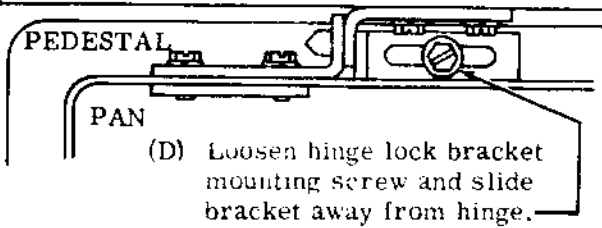

(F) Supporting the cover from the rear, remove by sliding sideways to separate hinges. The cover may be grasped as shown.

Note: Cover weighs approximately 39 pounds.

To replace cover, reverse removal procedure.

2.03 Upper Cover Arrangement

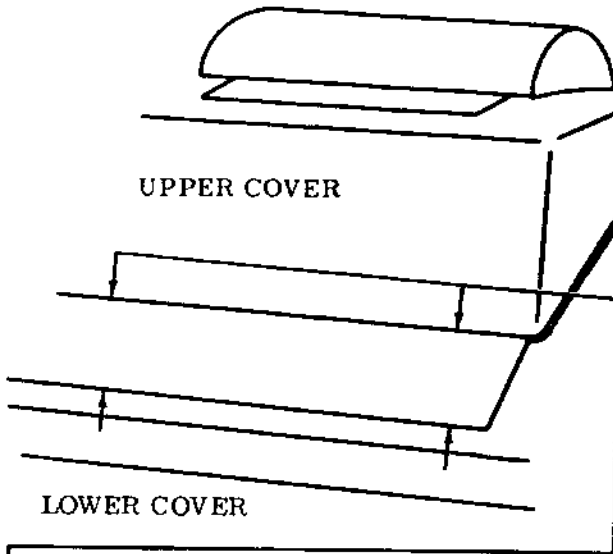

**(A) UPPER COVER POSITION (FRONT TO REAR)**

**Requirement**

Clearance between front of upper cover and edge of keyboard opening in lower cover (right and left ends of window depression) should be  
 ---Min 4-1/2 inches---Max 4-5/8 inches

**To Adjust**

Position cover with three screws, at each hinge that mounts upper cover, loosened. See COUNTERBALANCE ARM illustration.

**(B) UPPER COVER CLEARANCE (LATCHED)**

**(1) Requirement**

Rubber grommets should be slightly compressed.

**(2) Requirement**

There should be no metal-to-metal contact between upper and lower covers.

**(3) Requirement**

Clearance between upper cover and lower cover should be  
 0.090 inch maximum at sides and 0.200 inch maximum at rear.

**To Adjust**

Position cover with two screws, that mount each hinge to lower cover, loosened.

**Note:** This adjustment should be made in conjunction with the latch adjustment.

**(C) LATCH**

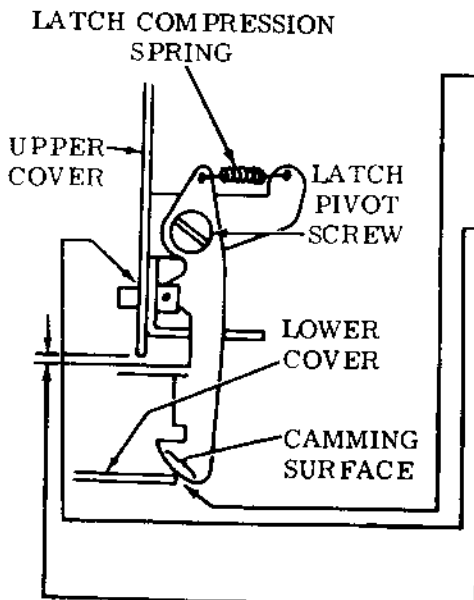

**(1) Requirement**

Without depressing latch buttons as upper cover is lowered, camming surfaces of latches should contact lower cover.

**(2) Requirement**

Latch button should not become disengaged from guide slot in cover when fully depressed.

**(3) Requirement**

All requirements of upper cover clearance adjustment should be met. Upper cover should latch closed with slight compression of rubber bumpers and no metal-to-metal contact.

**To Adjust**

Position both latches with their pivot screws loosened.

**Note:** This adjustment should be made in conjunction with the UPPER COVER CLEARANCE adjustment.

2.04 Upper Cover Arrangement (continued)

(D) COUNTERBALANCE ARM

(1) Requirement

There should be no free fall of upper cover from any position to which it is opened.

(2) Requirement

There should be some pressure required to close upper cover.

To Adjust

Tighten spring tension adjusting screws.

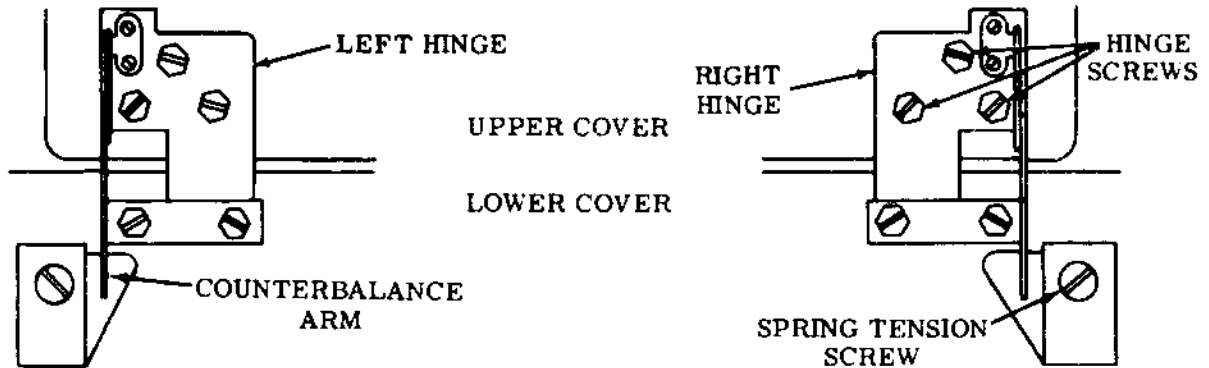

2.05 Copylight and Line Guide Copyholder

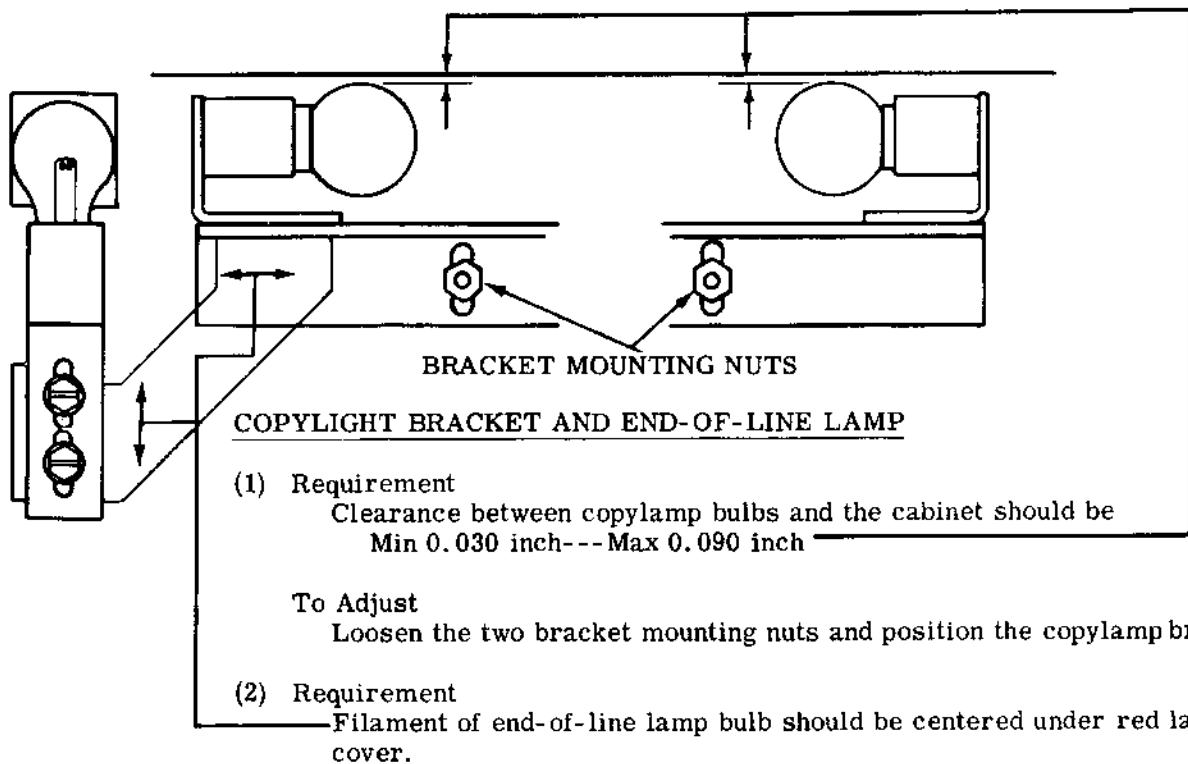

To Adjust

Loosen the two bracket mounting screws and position the end-of-line lamp bracket.

2.06 Copyright and Line Guide Copyholder (continued)

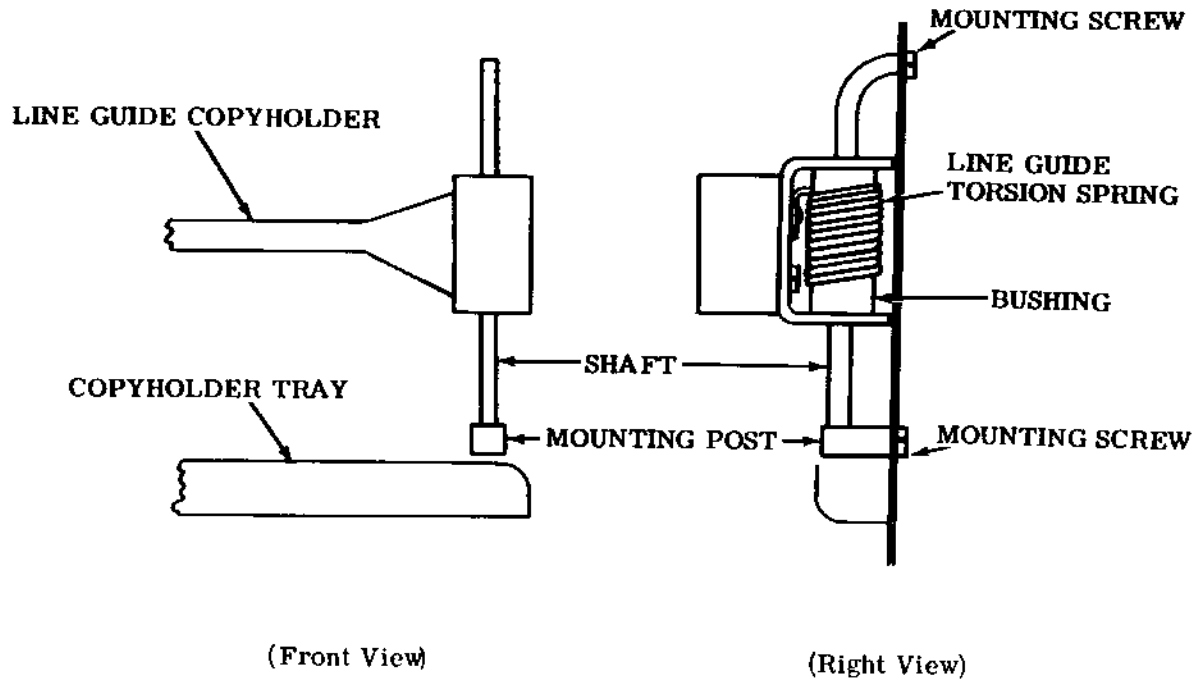

LINE GUIDE COPYHOLDER

**Requirement**

Tension of line guide copyholder should be just sufficient to hold copy in place and prevent the line guide copyholder from slipping down the shaft.

**To Adjust**

Remove two shaft mounting screws from inside cover and take off line guide copyholder. Remove line guide from shaft and rotate bushing in direction to increase or decrease torsion spring tension against line guide. Reassemble line guide and reinstall on cover.



2.07 Bubble and Window Position

Note: Adjustments on this page are preliminary. Final adjustments to be made with typing unit in place.

(C) WINDOW (PRELIMINARY)

(1) Requirement

Clearance between rear edge of window and front edge of paper guide on bubble should be Min 0.045 inch---Max 0.095 inch

(2) Requirement

Clearance should not differ at each end of paper guide by more than 0.030 inch.

To Adjust

Loosen four screws which mount two window clamps and position window.

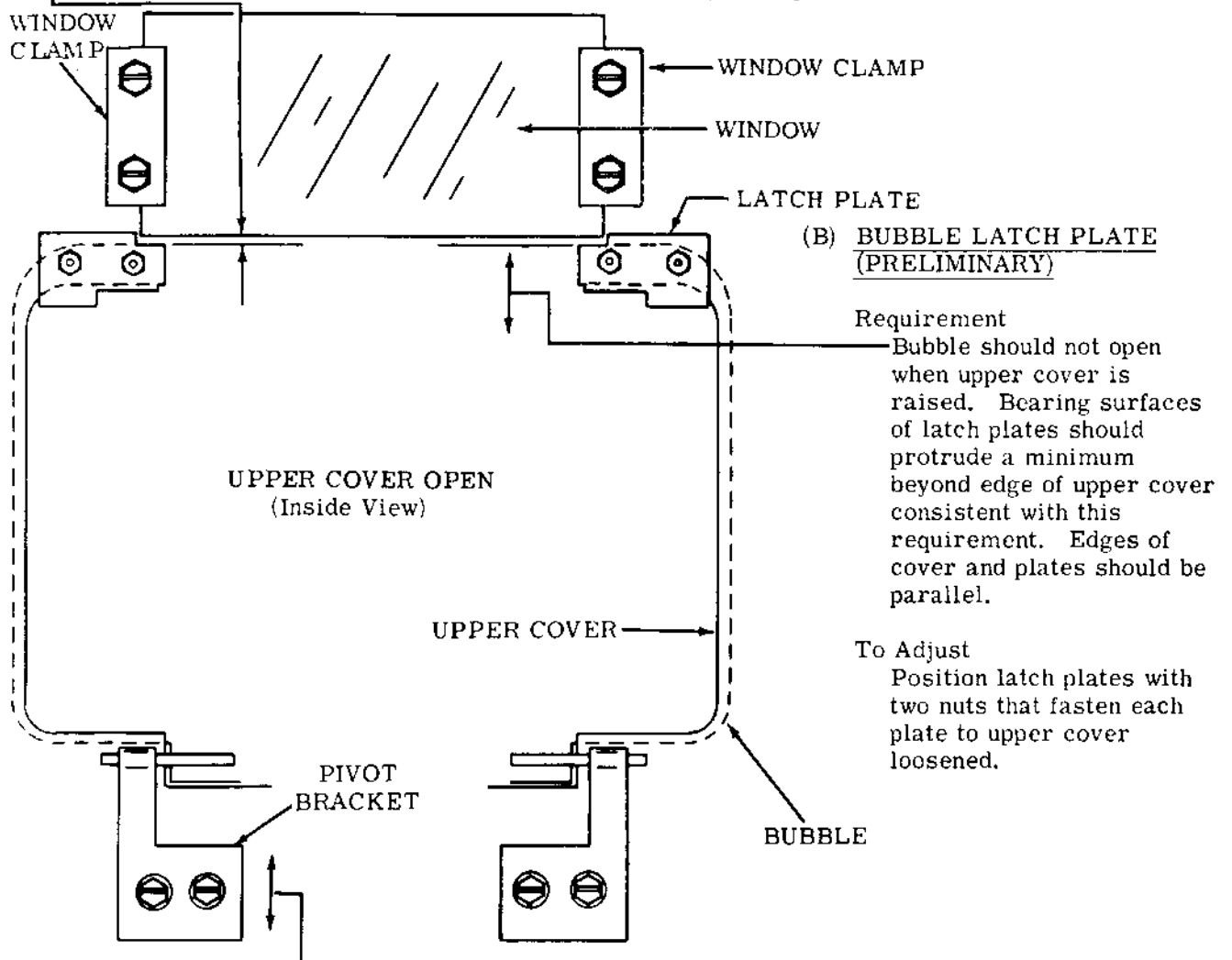

(B) BUBBLE LATCH PLATE (PRELIMINARY)

Requirement

Bubble should not open when upper cover is raised. Bearing surfaces of latch plates should protrude a minimum beyond edge of upper cover consistent with this requirement. Edges of cover and plates should be parallel.

To Adjust

Position latch plates with two nuts that fasten each plate to upper cover loosened.

(A) BUBBLE POSITION, FRONT AND REAR (PRELIMINARY)

Requirement

This bubble should be in the center of its frontmost and rearmost positions.

To Adjust

Loosen two mounting screws that mount each pivot bracket and position bubble, tighten screws.

2.08 Cradle Adjustments (Earlier Design)

(A) CRADLE HEIGHT (PRELIMINARY)

Requirement  
Distance from pan to top of cradle at four corners should be 1-3/16 inches.

To Adjust  
Loosen four cradle mounting screws. Turn adjustment bushing from beneath cabinet through access holes. Tighten cradle mounting screws.

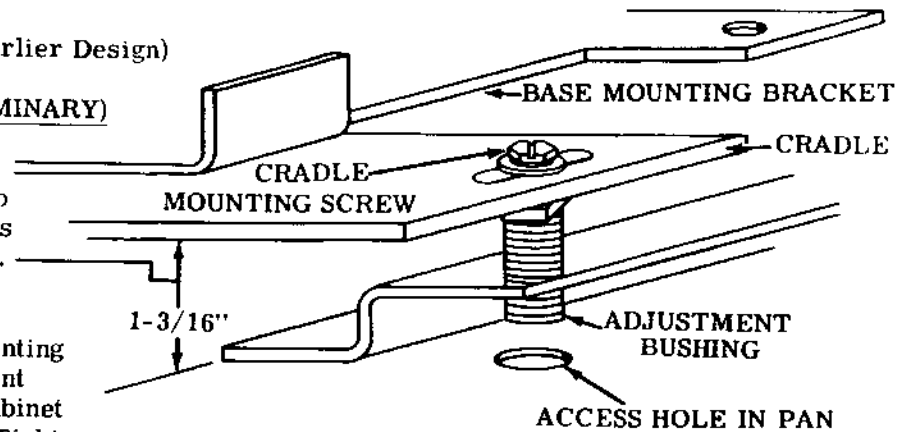

Note: CRADLE FRONT TO REAR adjustment may be disturbed by jarring the cabinet or base. Before making adjustment, seat keyboard base firmly on centers of rubber mounts.

(C) CRADLE FRONT TO REAR

KSR Requirement (Motor and Typing Unit in Place)

- (a) Clearance between cover and front edge of keyboard should be  
Min 0.060 inch---Max 0.090 inch
- (b) Clearance between top front edge of keylever guideplate and upper surface of cover should be  
Min 0.047 inch---Max 0.090 inch

RO Requirement (Motor and Typing Unit in Place)

- (a) Cradle should be approximately in center of its front to rear adjustment.
- (b) Front edge of base should be parallel to front edge of cover.

To Adjust  
Move cradle front or rearward with cradle mounting screws loosened. Refine cradle height if necessary. Tighten screws.

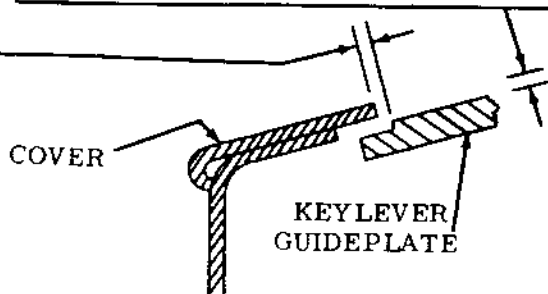

(B) CRADLE HEIGHT (FINAL)

KSR Requirement (Motor and Typing Unit in Place)

- (a) Clearance between top of keylever guideplate and upper edge of cover should be  
Min 0.047 inch---Max 0.090 inch
- (b) Top of base at rear corners should be 3 inches above pan.

RO Requirement (Motor and Typing Unit in Place)

Top of base should be 3 inches above pan at four corners.

To Adjust  
Refine CRADLE HEIGHT (PRELIMINARY) adjustment.

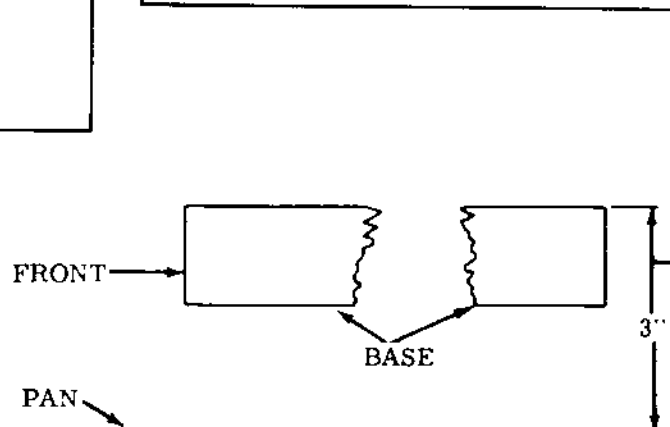

2.09 Cradle Adjustments (Later Design)

(A) CRADLE HEIGHT (PRELIMINARY)

Requirement

Distance from pan to top of cradle at four corners should be 1-3/16 inches.

To Adjust

Loosen four cradle mounting screws. Turn adjustment bushings from beneath cabinet through access holes. Tighten cradle mounting screws.

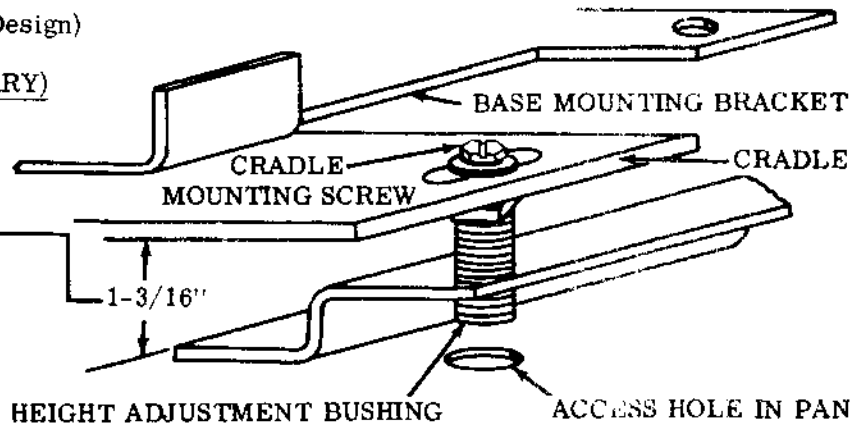

(B) CRADLE HEIGHT (FINAL)

Requirement

Motor and typing unit in place, distance from pan to top of base at four corners should be Min 2-15/16 inches---Max 3-1/16 inches

To Adjust

Loosen four cradle mounting screws. Turn adjustment bushings from beneath cabinet through access hole until requirement is met.

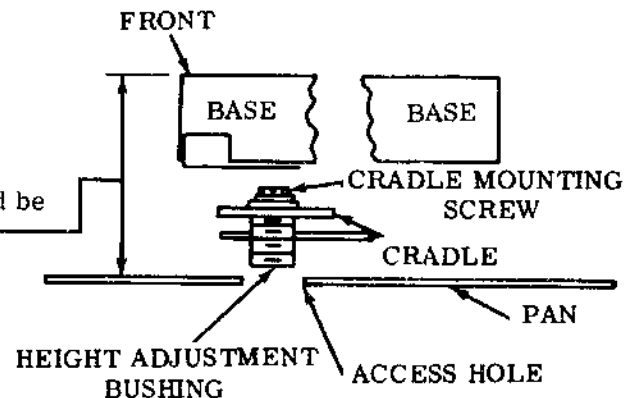

**Note:** CRADLE FRONT TO REAR adjustment may be disturbed by jarring the cabinet on base. Before making adjustment, seat keyboard base firmly on center of rubber mounts.

(C) CRADLE FRONT TO REAR

Requirement

Clearance between cover and front edge of keyboard should be Min 0.060 inch---Max 0.090 inch

To Adjust

Move cradle to front or rear until requirement is met. Tighten cradle mounting screws.

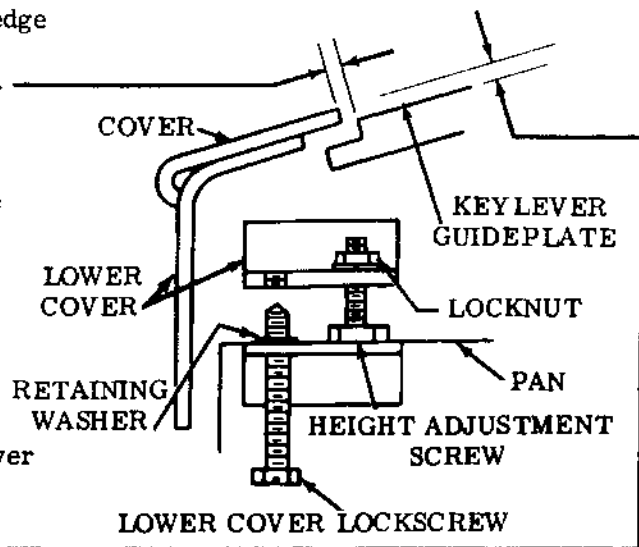

(D) FRONT HEIGHT OF LOWER COVER

Requirement

Clearance between upper edge of cover and top edge of keylever guideplate should be Min 0.047 inch---Max 0.090 inch

To Adjust

Loosen locknut on height adjustment screw. Turn screw until requirement is met. Tighten locknut.

## 2.10 Control Panel

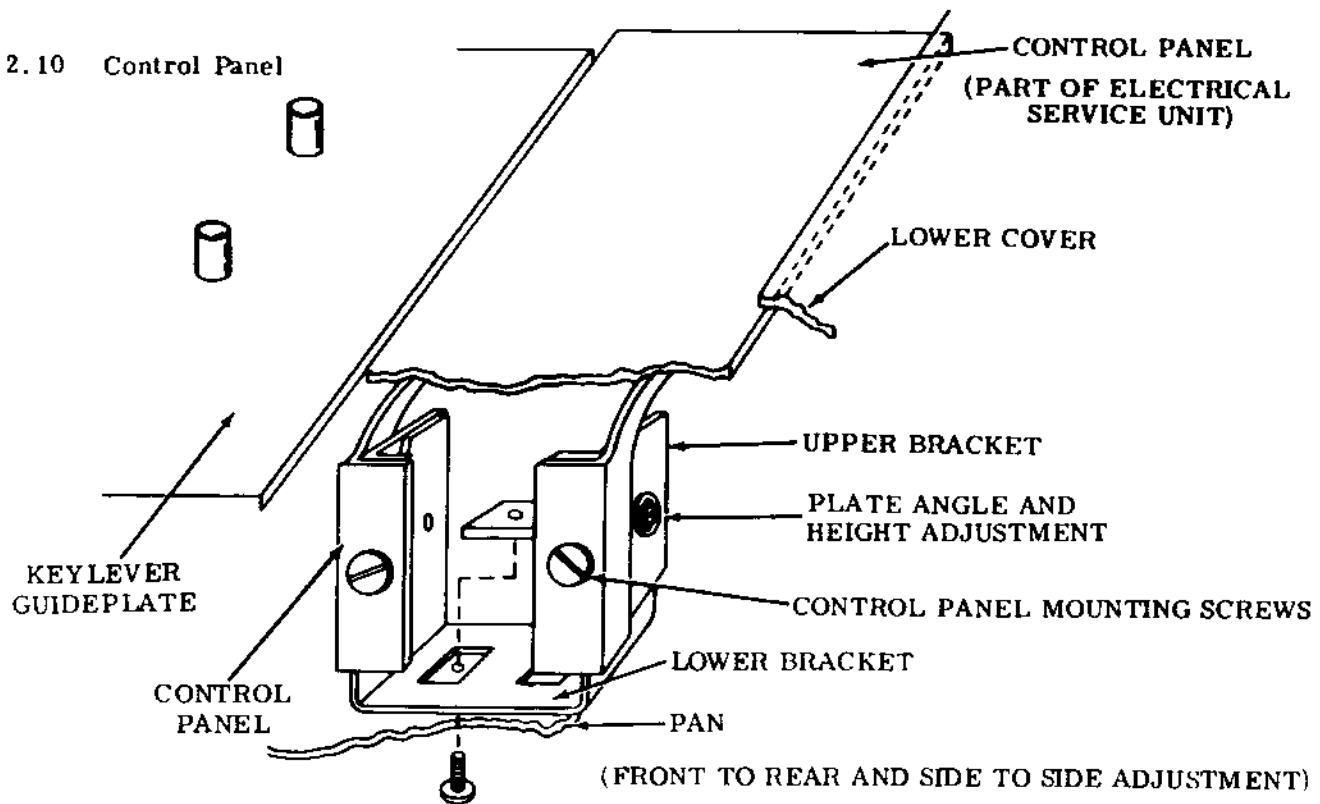

Note: Adjustments on this page may be disturbed by jarring the cabinet or base.  
Before making adjustment seat keyboard base firmly on centers of rubber mounts.

CONTROL PANEL

## KSR Requirements

- (a) Clearance between control panel tops and under surface of lower cover should be  
Min Panels may touch but not moved in excess of 0.015 inch by cover  
Max 0.060 inch
- (b) Clearance between keytop guideplate and adjacent control panels should be  
Min 0.060 inch---Max 0.090 inch

## RO Requirements

- (a) Clearance between control panel tops and under surface of lower cover should be  
Min Panels may touch but not moved in excess of 0.015 inch by cover  
Max 0.060 inch
- (b) Keylevers that protrude through panel should be vertical and should not bind in openings in panel.

## To Adjust (Earlier Design)

Loosen lower bracket mounting screws to friction tight and position brackets from left to right and front to rear. Loosen upper bracket mounting screws and adjust height and angle of control panels. Tighten screws. Make certain that cover rests on its support surfaces and not on control panels.

## To Adjust (Later Design)

Loosen lower bracket mounting screws to friction tight and position brackets from left to right and front to rear. Loosen upper bracket mounting screws to friction tight and raise brackets to uppermost position. Lower the cover to push control panels down to proper positions. Raise cover and tighten mounting screws.

2.11 Paper and Form Guides

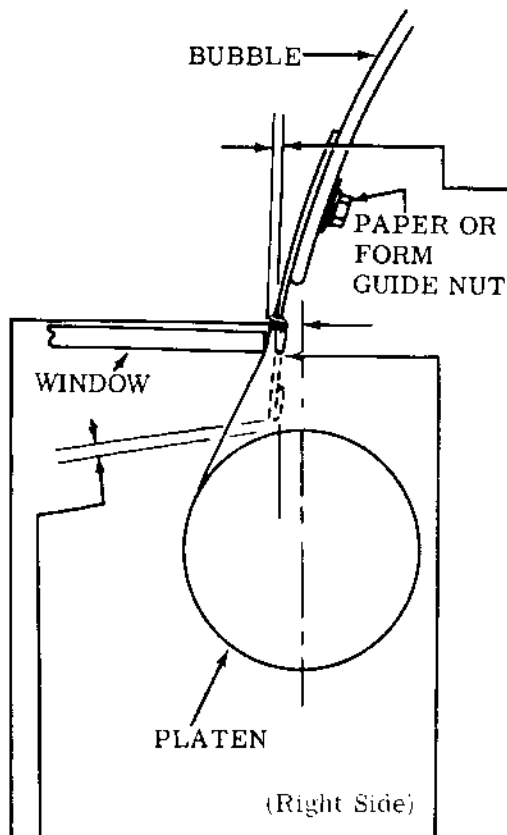

(D) WINDOW (FINAL)

Friction Feed Paper Guide Requirement

- (a) Clearance between rear edge of window and front edge of paper guide on bubble should be  
Min 0.045 inch---Max 0.095 inch
- (b) Clearance should not differ at each end of paper guide by more than 0.030 inch.

To Adjust

Loosen four screws that fasten window clamps (see 2.05) and position window. Tighten screws.

Sprocket Feed Form Guide Requirement

- (a) Clearance between rear edge of window and front edge of form guide on bubble should be  
Min 0.045 inch---Max 0.095 inch
- (b) Clearance should not differ at each end of paper guide by more than 0.030 inch. If stapled stationery is used, clearance should be increased to allow four or more copies to pass freely through paper emission slot.

To Adjust

Same as adjustment above.

(C) PAPER AND FORM GUIDE

Friction Feed Paper Guide Requirement

Bottom edge of paper guide should be flush with bottom surface of window.

Sprocket Feed Form Guide Requirement

Clearance between form guide and platen should be  
Min 3/64 inch---Max 5/64 inch

To Adjust

Position guide with three paper or form guide nuts loosened. Tighten nuts.

(A) BUBBLE POSITION FRONT AND REAR (FINAL)

Requirement

Front edge of paper or form guide should be about 1/4 inch in front of approximate center of platen. Form guide and bubble should clear all typing unit parts by at least 1/8 inch.

To Adjust

Loosen four mounting screws that mount bubble pivot brackets and position bubble (see 2.05). Tighten screws.

(B) BUBBLE LATCH PLATE (FINAL)

Refine 2.05, BUBBLE LATCH PLATE (PRELIMINARY), if necessary.

2.12 Call Control Unit Apparatus Mounting Rack

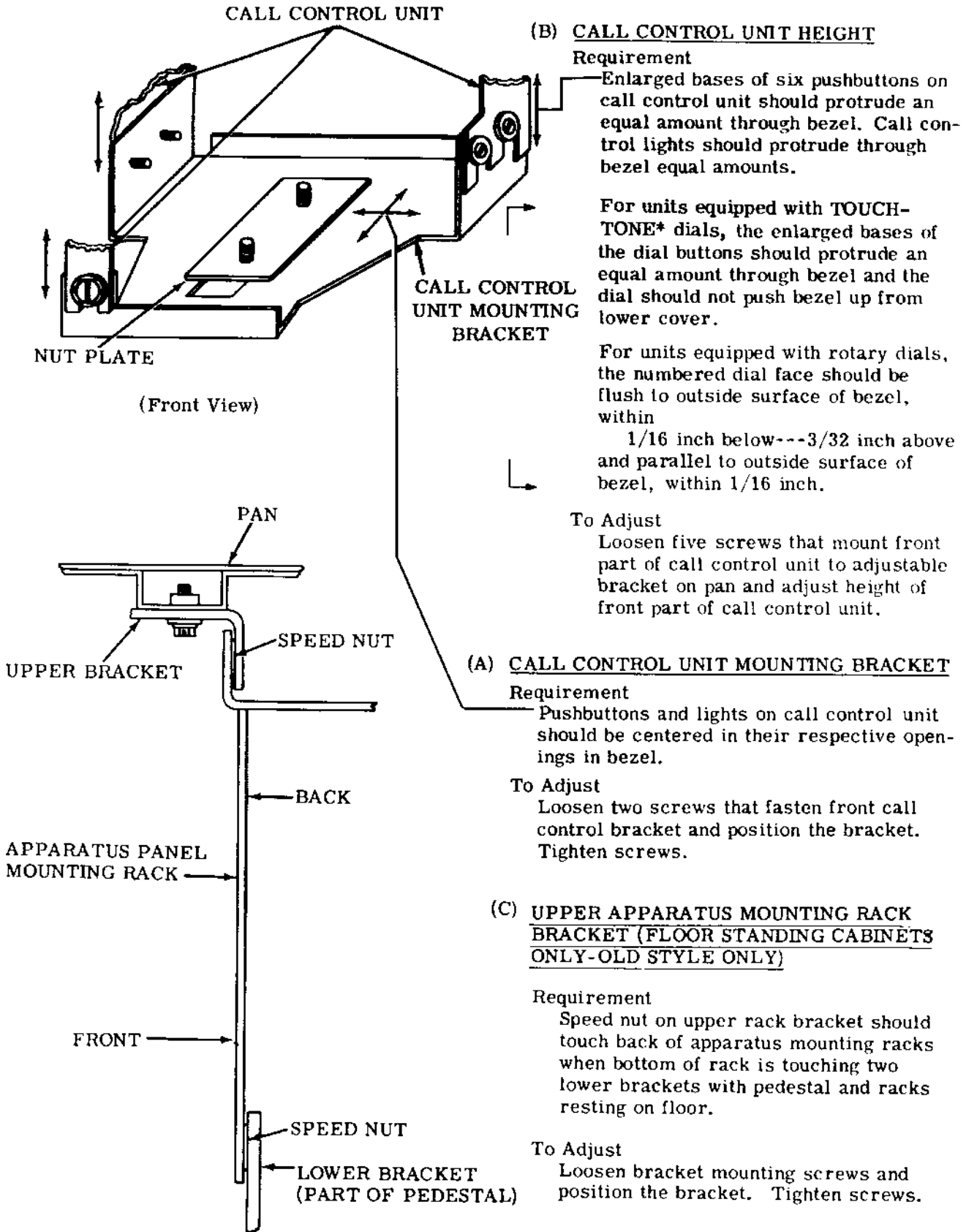

\* Registered Service Mark of AT&TCo.

## 2.13 Lower Cover Latch (Later Design Only)

LOWER COVER LATCH

## (1) Requirement

Latching surface should be parallel as gauged by eye.

## (2) Requirement

Clearance between lower cover latch and latching surface should be

Min some---Max 0.060 inch

## To Adjust

Loosen bracket mounting screws and latch mounting nut and make them friction tight. Position latch and bracket until requirements are met. Tighten mounting nut and mounting screws.

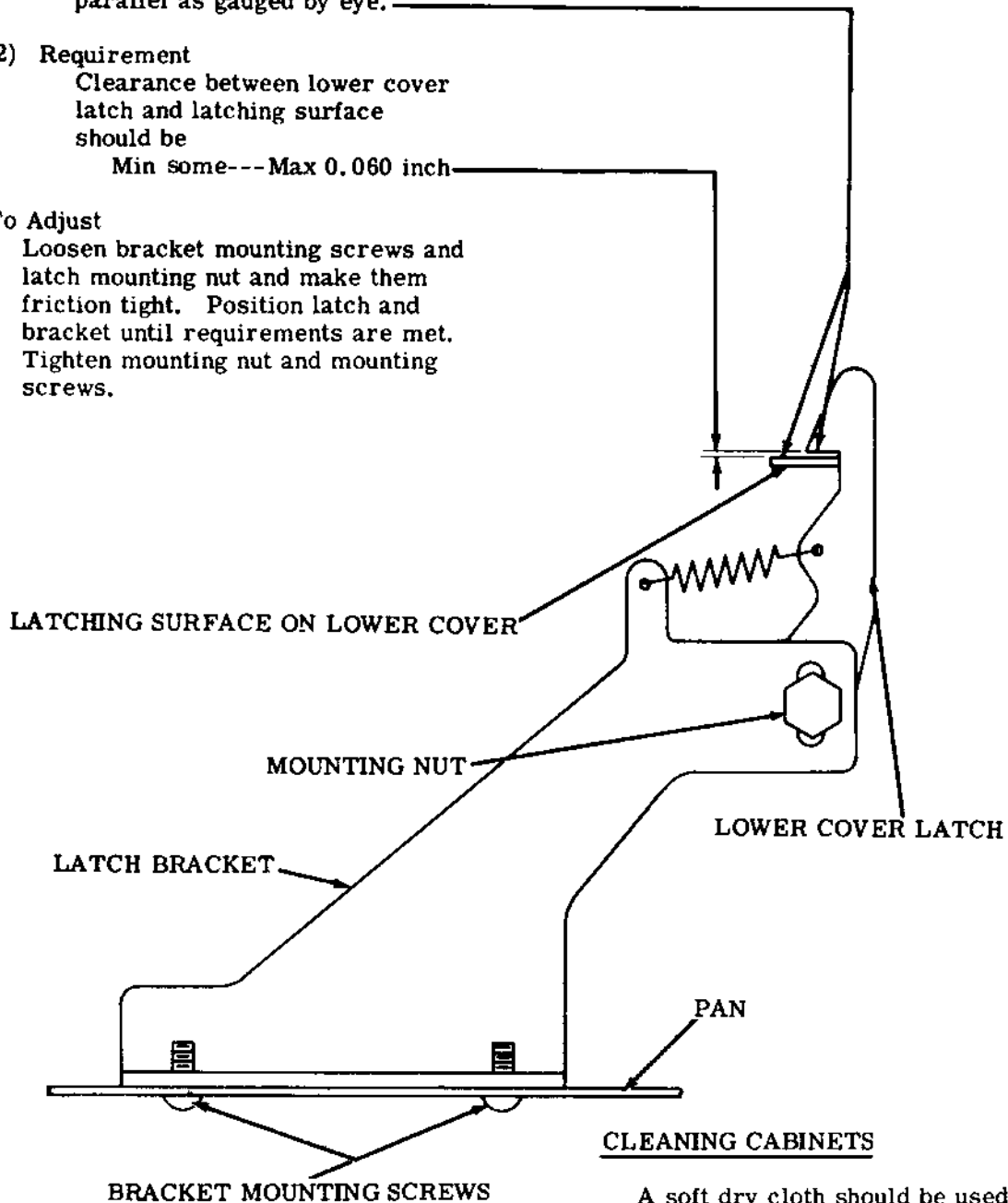

A soft dry cloth should be used to remove dust, oil or grease from the cabinet. If necessary, a soft damp cloth and mild soap may be used. Rinse cabinet with damp cloth and buff with a dry cloth.

**CAUTION:** DO NOT USE ALCOHOL, MINERAL SPIRITS OR OTHER SOLVENTS FOR CLEANING THE CABINET.

2 14 Lower Panel Pivot Post

LOWER PANEL PIVOT POST

(1) Requirement

Maximum endplay of lower compartment panel on its pivot post should be 0.030 inch.

(2) Requirement

Clearance at sides of lower compartment panel with endplay taken up in one direction should not differ by more than 0.045 inch.

To Adjust

Lower panel until engaged with the pivot posts. Loosen locknuts. Position pivot posts until requirements are met. Tighten locknuts.

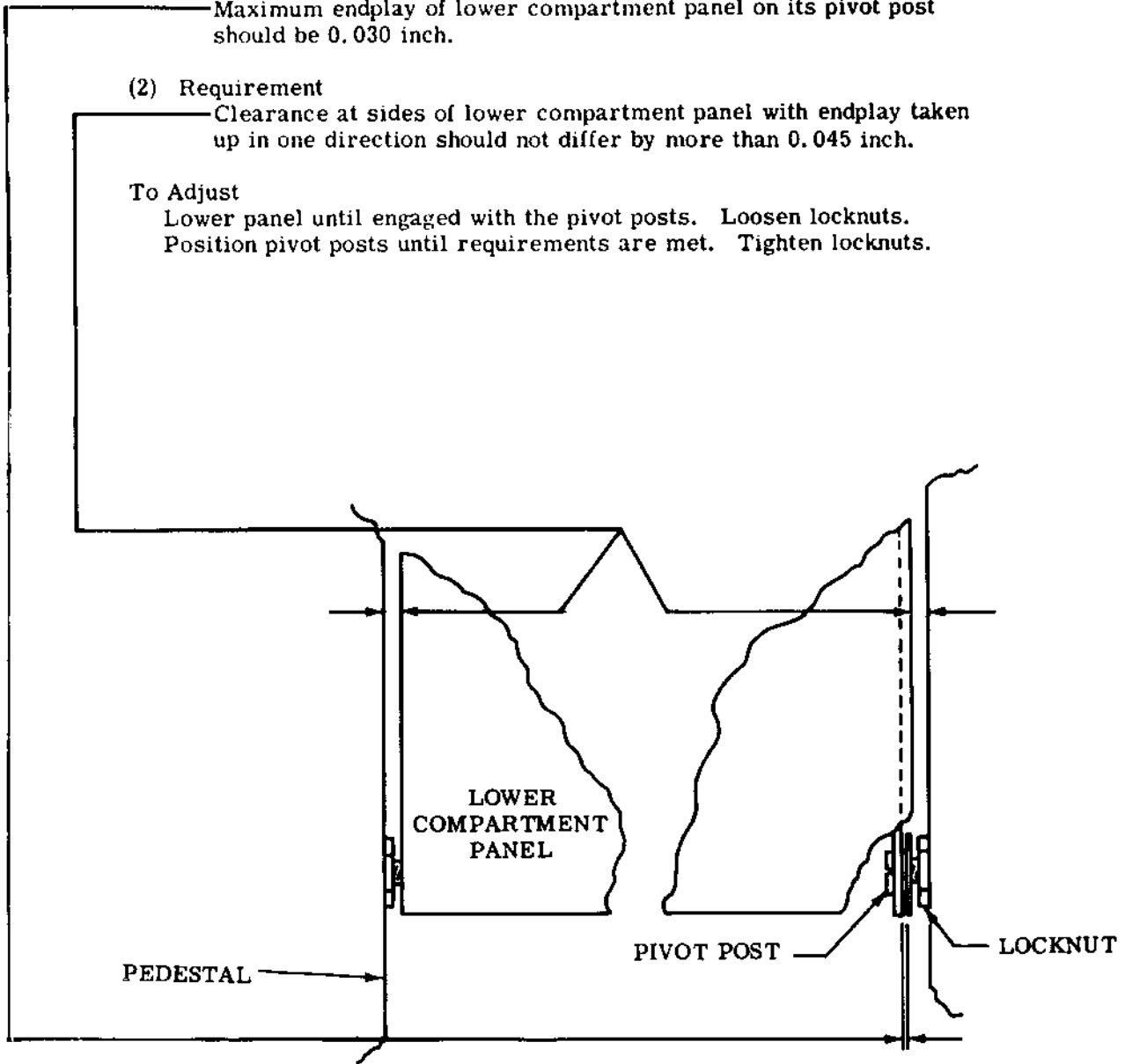



2.15 Vibration Hinge Mounts, Wall Mounted Printer Cabinet

FRAMEWORK MOUNTED ON BACKPLATE

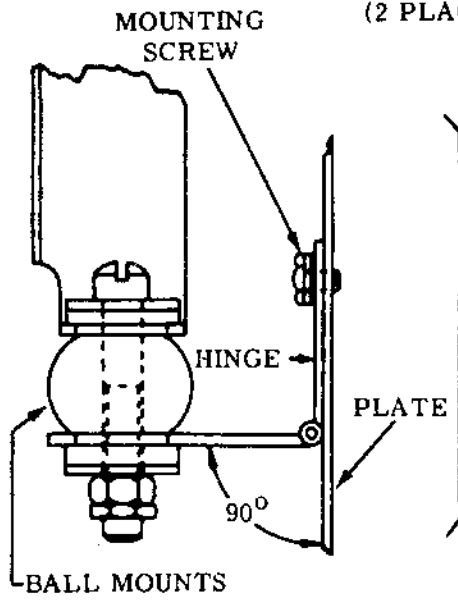
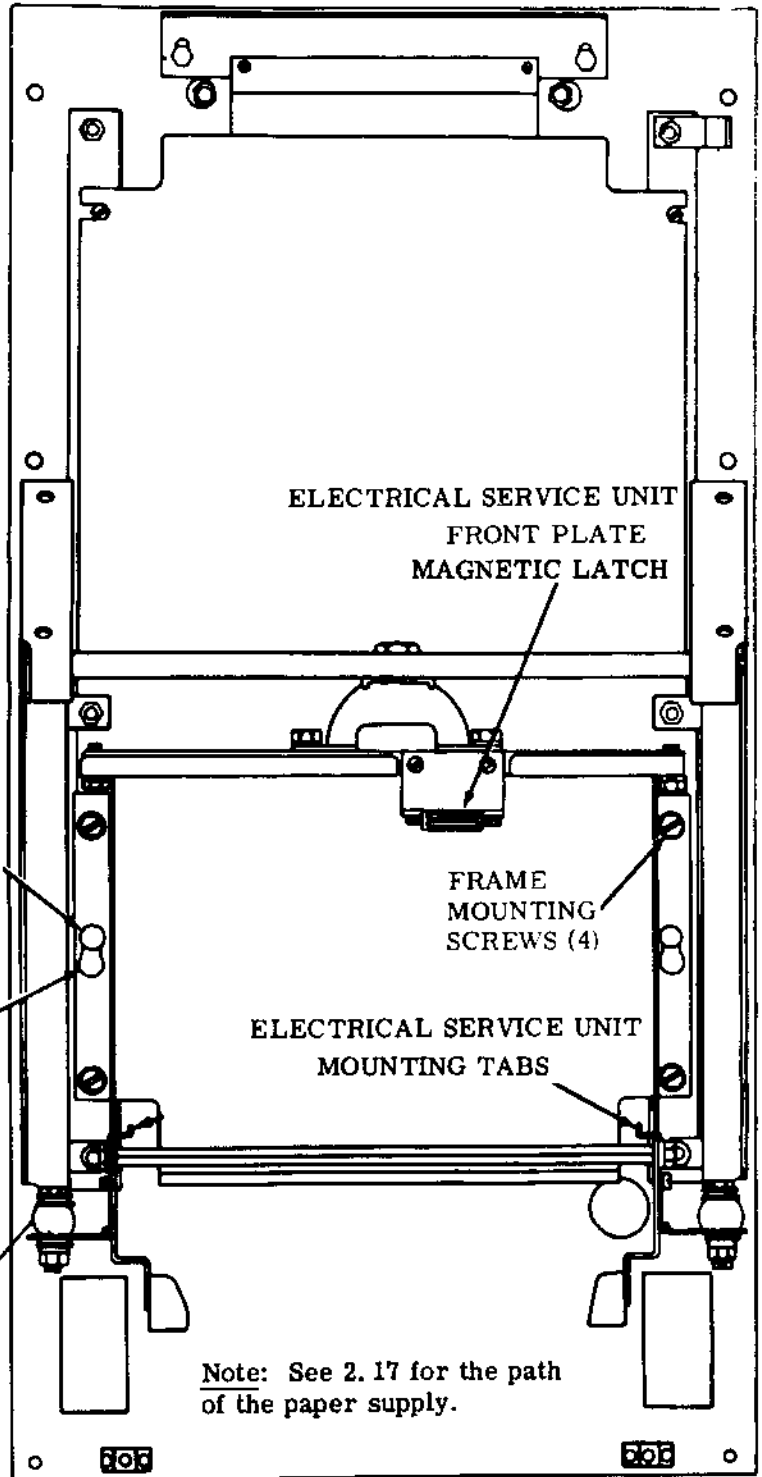
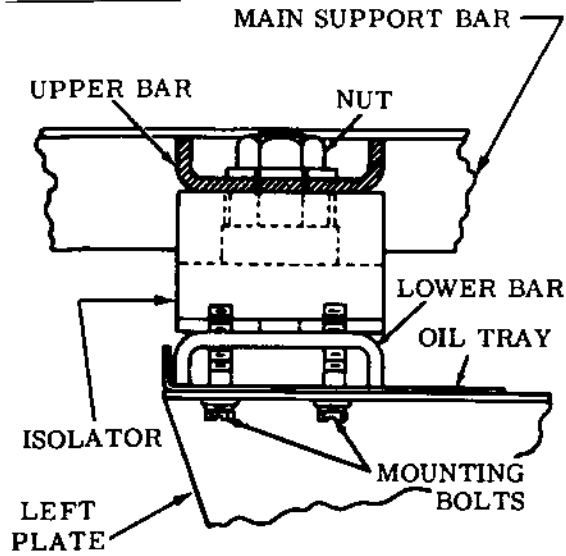

HINGE MOUNTS

**Requirement**

With keyboard (or receiving-only base), printer and motor unit in place, hinges should be perpendicular to side plate as gauged by eye. Check both sides.

**To Adjust**

Position hinges up or down with mounting screws loosened. Tighten screws.

2.16 Cover and Hood, Wall Mounted Printer Cabinet

(A) KEYTOP GUIDEPLATE HOOD (SEND-RECEIVE UNIT)

Requirement

With cover in place, clearance between keyboard hood and keytop guideplate should be

Min 0.090 inch---Max 0.125 inch

To Adjust

Loosen two nuts on cover mounting bar and lower screws. Position eccentrics. Tighten nuts and screws.

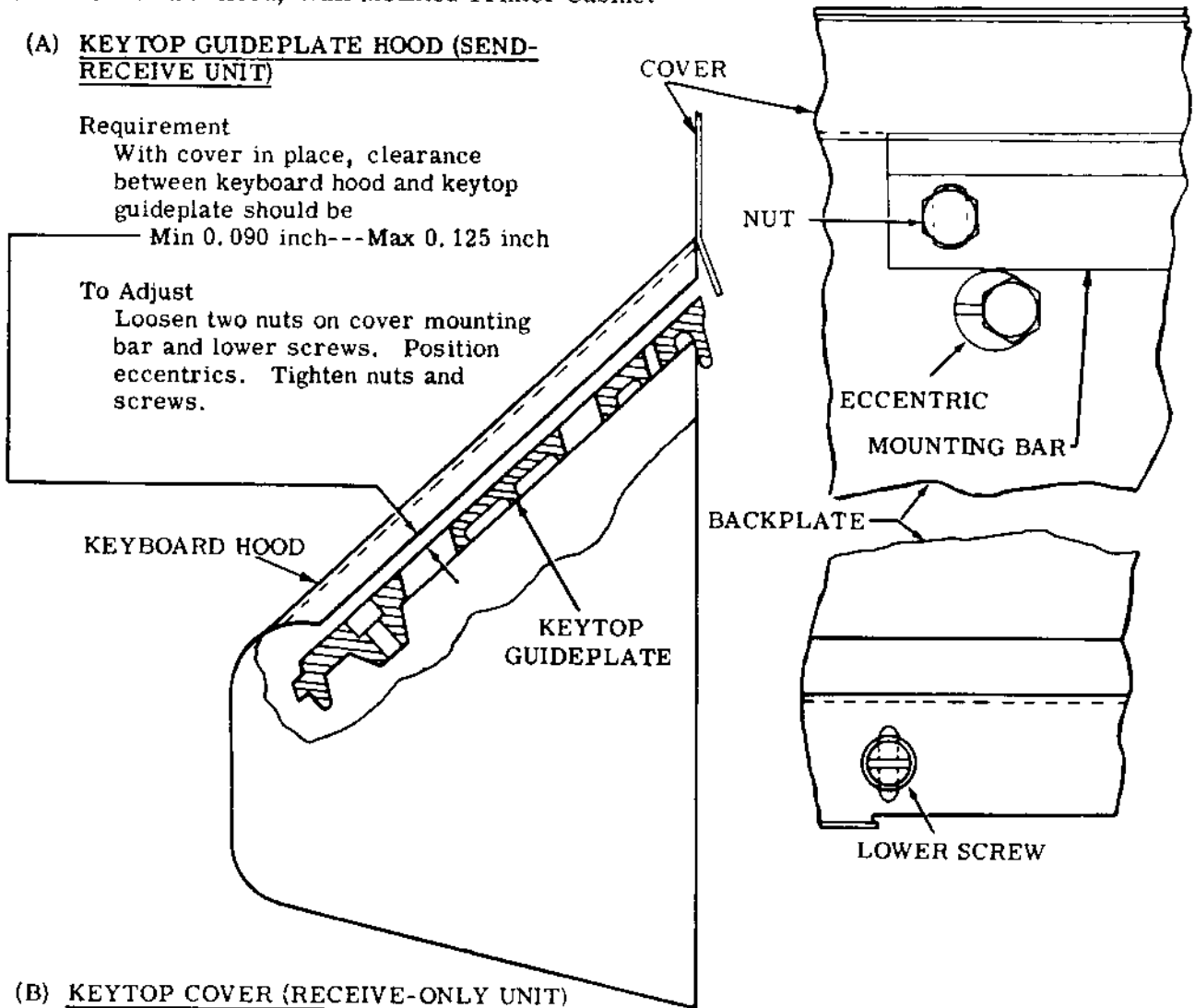

(B) KEYTOP COVER (RECEIVE-ONLY UNIT)

Requirement

With cover in place, power switch should be centrally located in its cover opening.

To Adjust

Loosen two nuts on cover mounting bar and lower screws. Position eccentrics. Tighten nuts and screws.

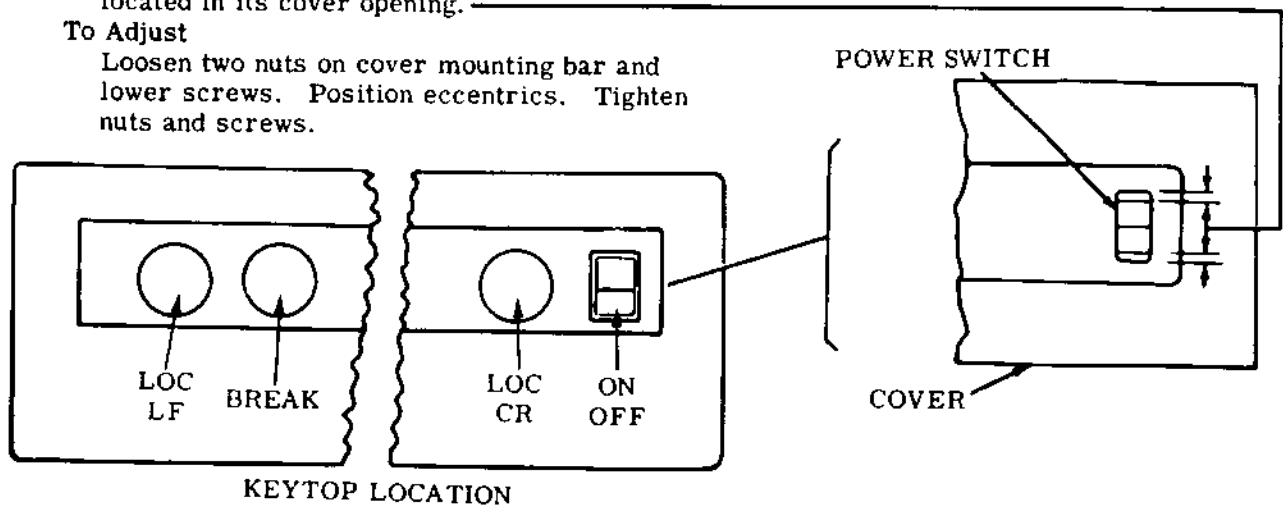

2.17 Cover and Power Switch, Wall Mounted Printer Cabinet

(A) KEYTOP GUIDE AND COVER (SEND-RECEIVE UNIT)

(1) Requirement

With cover in place, clearance between rear edge of keytop guide and lip of cover should be  
Min 0.090 inch---Max 0.125 inch

(2) Requirement

Clearance should be parallel as gauged by eye.

To Adjust

With nut which secures large central mount loosened, position upper support bar by means of its elongated slot. Tighten nut.

To Adjust

If parallel condition is not met by above adjustment, loosen four bolts securing lower support bar. Position lower support bar. Tighten bolts.

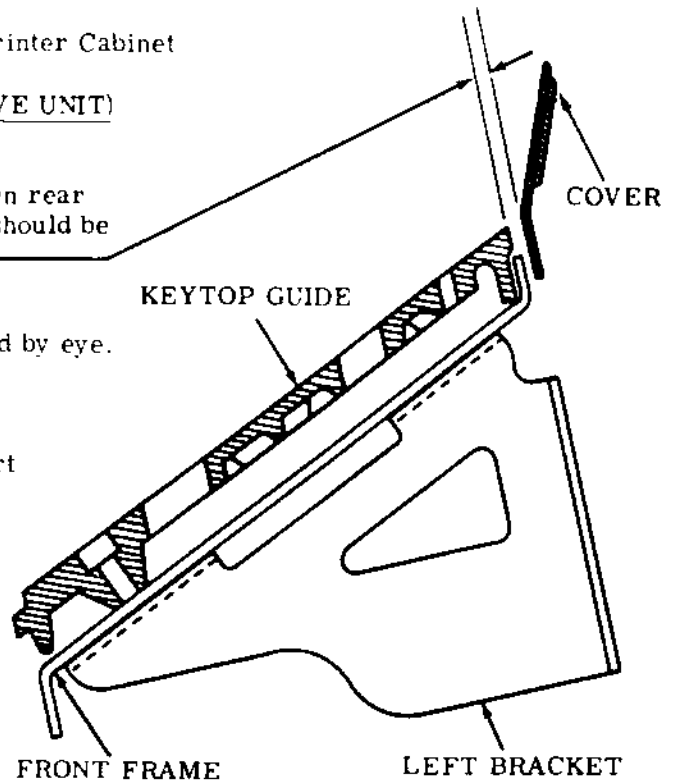

(B) POWER SWITCH (RECEIVE-ONLY UNIT)

Requirement

With cover in place, deflected surface of power switch, indicating either on or off, should be flush with cover surface.

To Adjust

With cover removed and adjusting screws friction tight, position switch. Tighten screws. Replace cover.

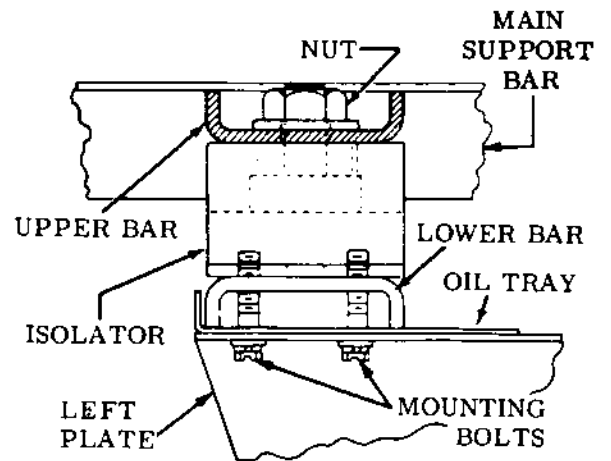
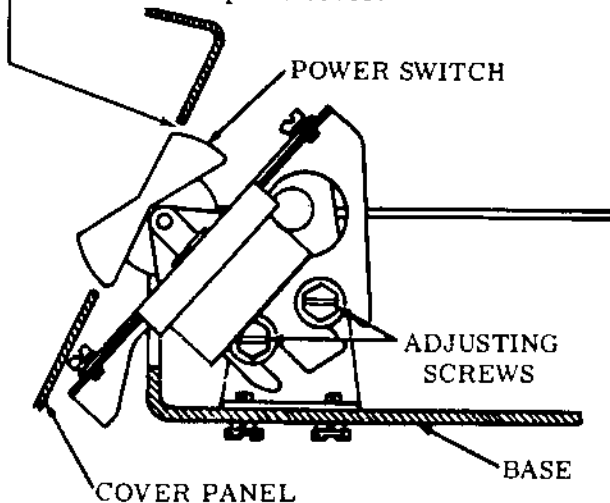

Note: Should additional adjustment be needed, loosen bolts securing large central mounting bracket and position upper bar.

2.18 Cover Door Latches and Hinge Mounts, Wall Mounted Printer Cabinet

**(A) CARRIAGE RETURN, LINE FEED, AND BREAK LEVER  
(RECEIVE-ONLY UNIT)**

**Requirement**

With cover in place, clearance between surface of lever adjusting screw and outer surface of cover should be  
Min 7/8 inch---Max 15/16 inch

**To Adjust**

Remove cover. Remove keylever assemblies (3) from cover. (See 2.14.) Replace cover and turn adjusting screw through hole in cover. (Slot in screw should be horizontal after adjusting.) Remove cover and replace keylever assemblies. Insert keytops in their proper opening.

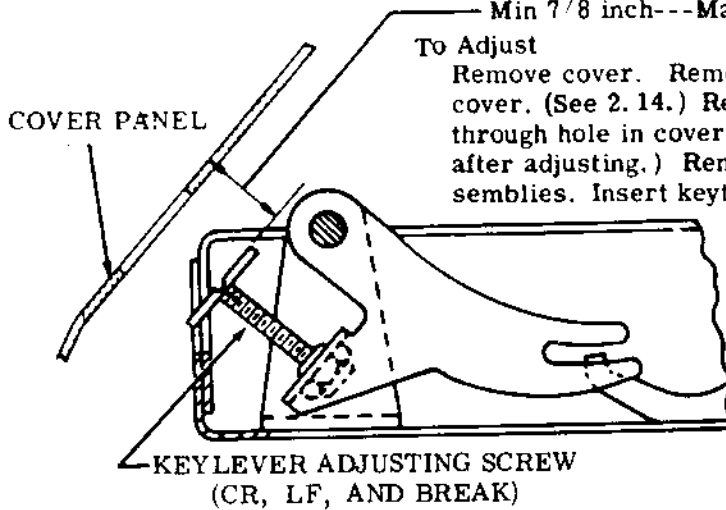

Remove keylever assembly (2 nuts, lockwashers, and flat washer).

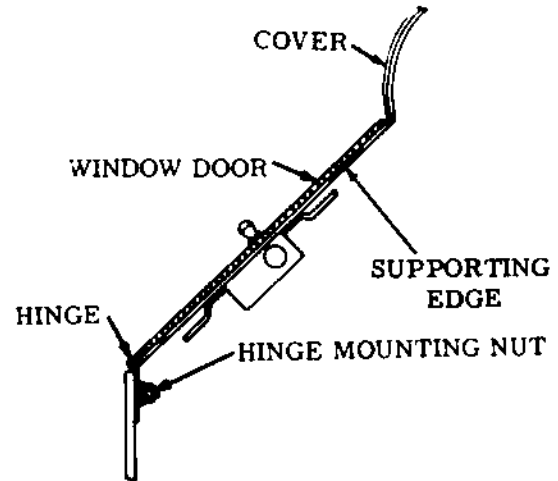

**(B) WINDOW DOOR HINGE MOUNTS**

**Requirement**

Window door should lie flat on supporting edges of cabinet as gauged by eye.

**To Adjust**

Loosen two nuts on each hinge. Position door. Tighten nuts.

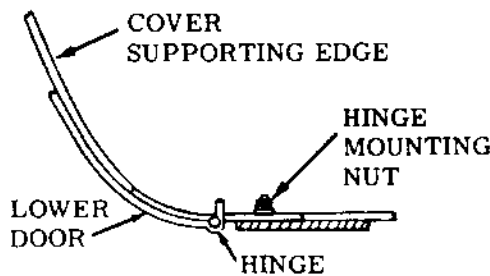

**(C) LOWER DOOR HINGE MOUNTS**

**Requirement**

Door should lie flat against cover.

**To Adjust**

Loosen two nuts on each hinge. Position door. Tighten nuts.

**(D) LOWER DOOR LATCHES**

**Requirement**

Door should latch solidly with magnetic latch and lie flat against cover.

**To Adjust**

Loosen latch screws. Position latches. Tighten screws.

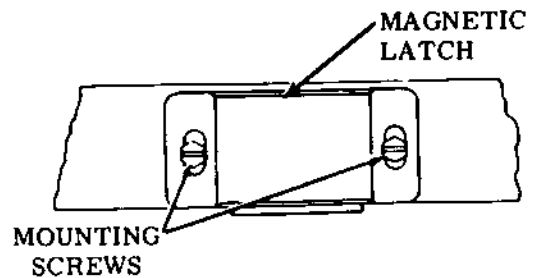

**SMALL COPYHOLDER (WITH LINE GUIDE)**

**Requirement**

See 2.04.

2.19 Paper Guide, Window, and Copylamps, Wall Mounted Printer Cabinet

(B) WINDOW

Requirement

With small door closed, parallel clearance between paper guide and edge of window should be

Min 0.080 inch---Max 0.110 inch

To Adjust

Loosen four mounting screws holding window clamps in position. Position window. Tighten screws.

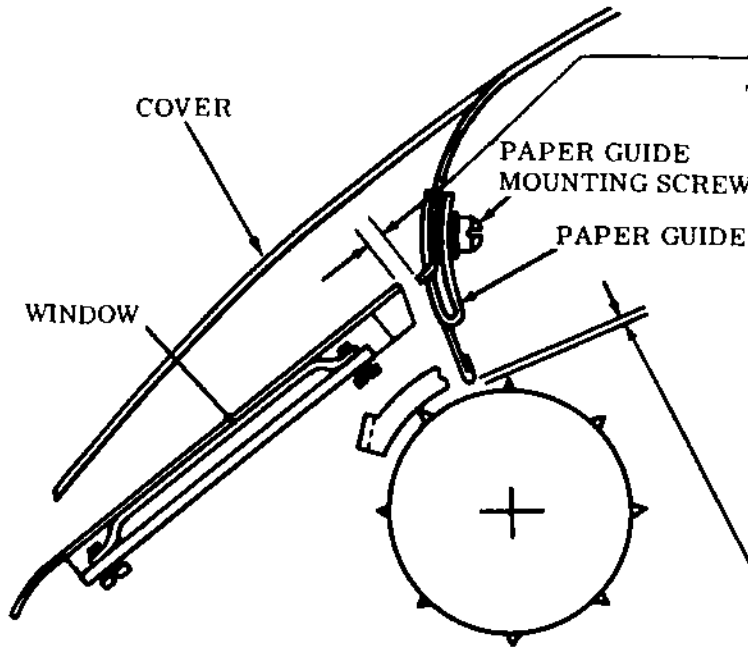

PATH OF PAPER

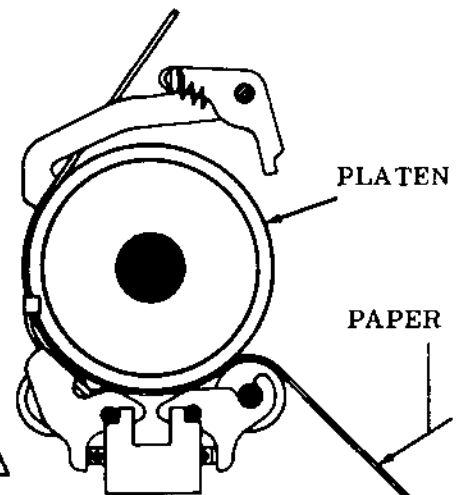

(A) PAPER GUIDE

Requirement

With typing unit in place, large and small doors latched, clearance between paper guide and platen should be

Min 3/64 inch---Max 5/64 inch

To Adjust

Loosen guide mounting screws and position guide parallel to platen. Tighten screws.

(C) COPYLAMPS

Requirement

With cover and light shield in place, clearance between lamp assembly and cover should be at least 1/16 inch.

To Adjust

Bend the bracket.

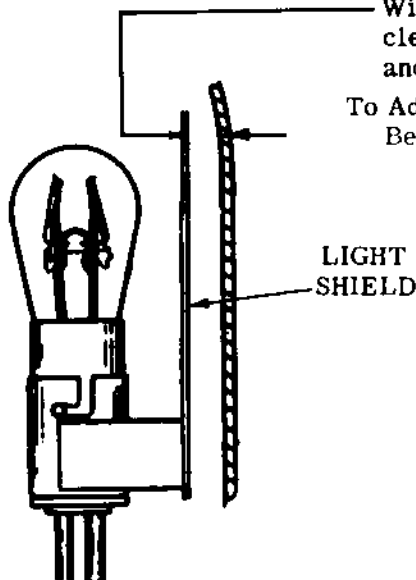

RIGHT END VIEW OF PAPER ROLL

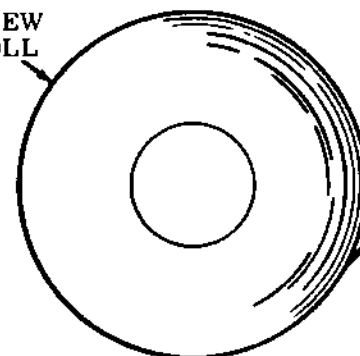

28 AND 35 ANSWER-BACK UNIT (LABD)

ADJUSTMENTS

CONTENTS	PAGE
1. GENERAL . . . . .	1
2. BASIC UNITS . . . . .	2
Trip Mechanism	
Armature extension gap . . . . .	2
Clutch trip magnet armature spring . .	3
Contact block position (final) . . . . .	3
Contact block position (preliminary) .	2
Lateral clutch spring . . . . .	11
Feed Mechanism	
Code drum contact wire spring . . . . .	6
Code drum detent spring . . . . .	6
Eccentric stop position . . . . .	5
Feed bail spring . . . . .	4
Feed pawl . . . . .	4
Feed pawl spring . . . . .	5
Relay Brackets and Contacts	
Motor hold and relay pull-up contact bracket . . . . .	6
Motor hold and relay pull-up contact .	7
Nonrepeat relay . . . . .	7
Distributor Brushes	
Brush holder spring . . . . .	8
Distributor brush holder . . . . .	8
Gear Backlash	
Gear backlash — ASR (transmitter base) . . . . .	10
Gear backlash — RO, KSR . . . . .	9
Gear backlash — self-contained unit .	9

1. GENERAL

1.01 This section is reissued to add coverage of the 5- and 8-level answer-back unit. The section has been revised to include recent engineering changes and additions and to rearrange the text. Since this is a general revision, marginal arrows ordinarily used to indicate changes and additions are omitted.

1.02 The adjustments in this section are arranged in a sequence that should be followed if a complete readjustment is undertaken. A complete adjusting procedure should be read before attempting to make the adjustment. After an adjustment is made, be sure to tighten any nuts or screws that may have been loosened, unless otherwise instructed.

1.03 The adjustment illustrations indicate tolerances, positions of moving parts, spring tensions, and the angle at which scales should be applied. The tools required to make adjustments and check spring tensions are not supplied with the equipment, but are listed in the appropriate section under separate cover. Springs which do not meet the requirements, and for which there are no adjusting procedures, should be discarded and replaced by new springs.

1.04 Where adjustment instructions call for removal of components, assemblies, subassemblies, or parts, all adjustments which the removal of these parts might facilitate should be made before the parts are replaced, or as the equipment is reassembled. When a part mounted on shims is removed, the number and location of shims should be noted so that the identical pile-up can be made when the part is replaced.

1.05 All electrical contact points should meet squarely. Contacts with the same diameter should not be out of alignment more than 25 per cent of the contact diameter. Check contacts for pitting and corrosion and clean or burnish them before making the specified adjustment or tolerance measurement. Avoid sharp kinks or bends in the contact springs.

Note: Keep all electrical contacts free of oil and grease.

1.06 References made to left or right, up or down, and front or rear apply to the answer-back unit as viewed from the side with

the answer-back mechanism to the left and the motor to the right.

1.07 Unless otherwise specified, where the stop position of the answer-back mechanism is referred to, the lugs of both the clutch release lever and shaft stop lever should be against the armature, with the armature exten-

sion resting in the stop indent of the code drum stop cam.

1.08 Instructions for coding the answer-back drum are not included in this section. Refer to the appropriate section covering installation of the answer-back unit for detailed coding instructions.

## 2. BASIC UNITS

### 2.01 Trip Mechanism

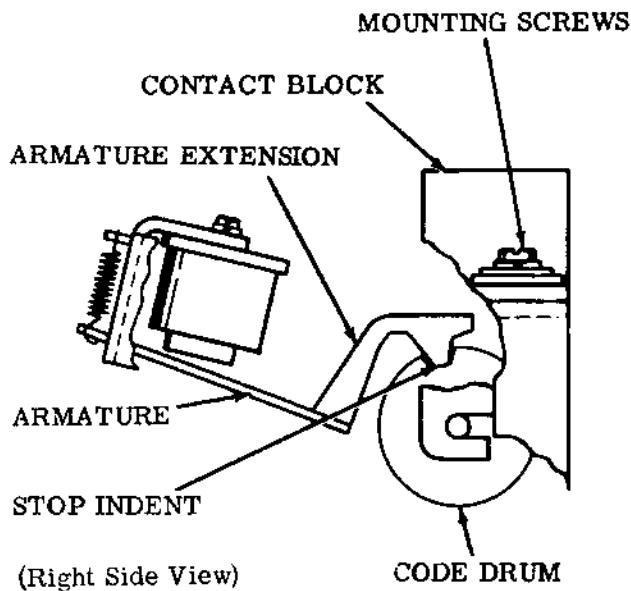

#### CONTACT BLOCK POSITION (Preliminary)

##### Requirement

Answer-back in stop position, armature extension must drop into stop indent in code drum stop cam.

##### To Adjust

Step code drum to last character. Rotate main shaft further until the motor hold cam allows armature to drop. Position the contact block until armature extension drops into indent with the contact block mounting screws loosened.

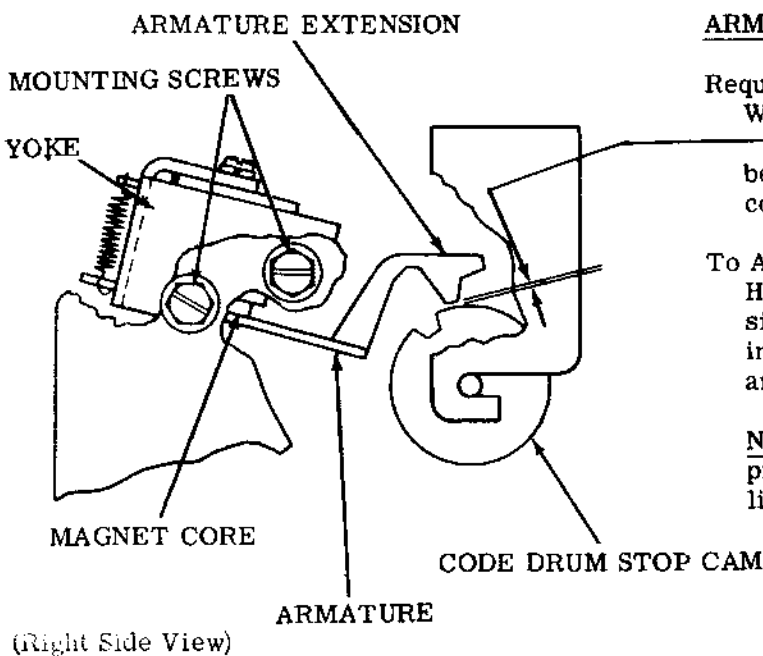

#### ARMATURE EXTENSION GAP

##### Requirement

With armature held against magnet core  
Min some---Max 0.015 inch  
between armature extension and high part of  
code drum stop cam.

##### To Adjust

Hold armature against magnet core and position magnet yoke assembly with its mounting screws friction tight. Recheck clearance after tightening screws.

**Note:** When holding armature against core, press between pivot and core to prevent lifting armature.

2.02 Trip Mechanism (continued)

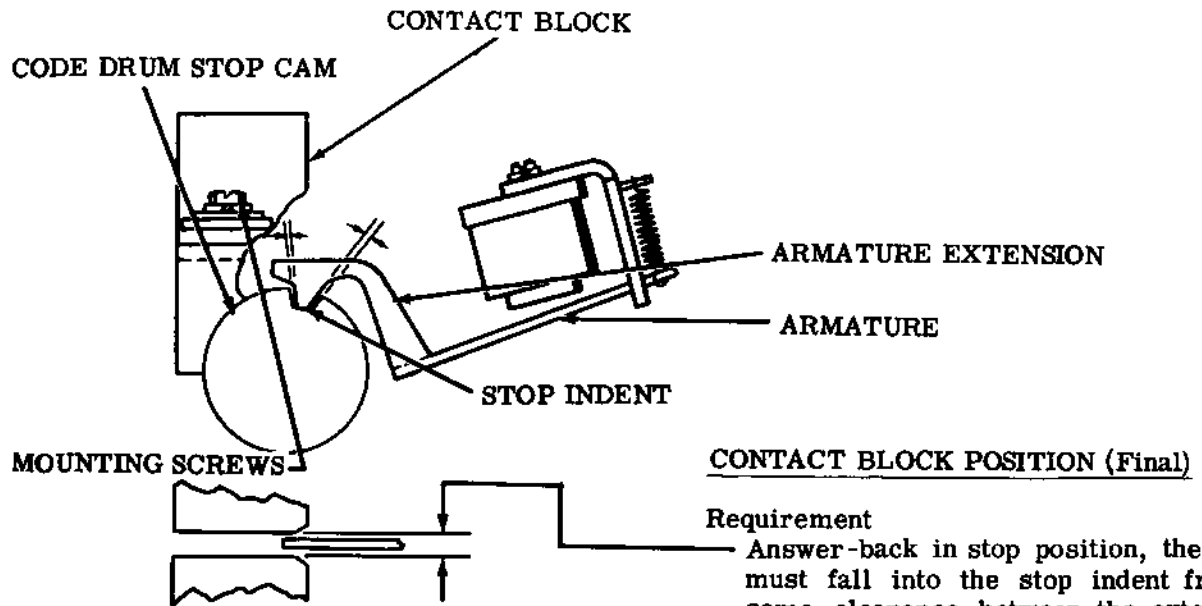

(Left Side View)

To Adjust

Position the contact block with its mounting screws loosened. Tighten screws.

Note: Keep back of block approximately parallel and in line with back of frame.

CLUTCH TRIP MAGNET ARMATURE SPRING

Requirement

Min 7 oz---Max 9 oz  
to start heel end of armature moving.

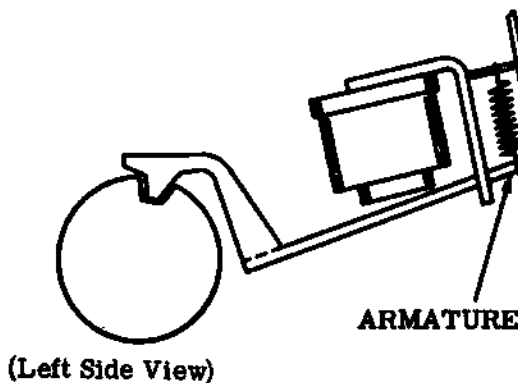

(Left Side View)



2.03 Feed Mechanism

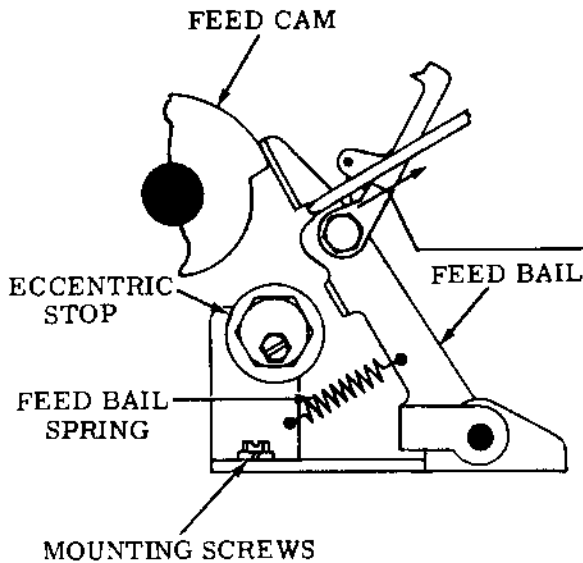

(Right Side View)

FEED BAIL SPRING

Requirement  
 With code drum removed and feed bail on high part of its cam  
 Min 15 oz---Max 17 oz  
 to start bail moving.

To Adjust  
 With bracket mounting screws friction tight, position bracket to increase or decrease tension. Tighten screws.

Note: When new code drum is installed, refine spring tension toward 17 ozs.

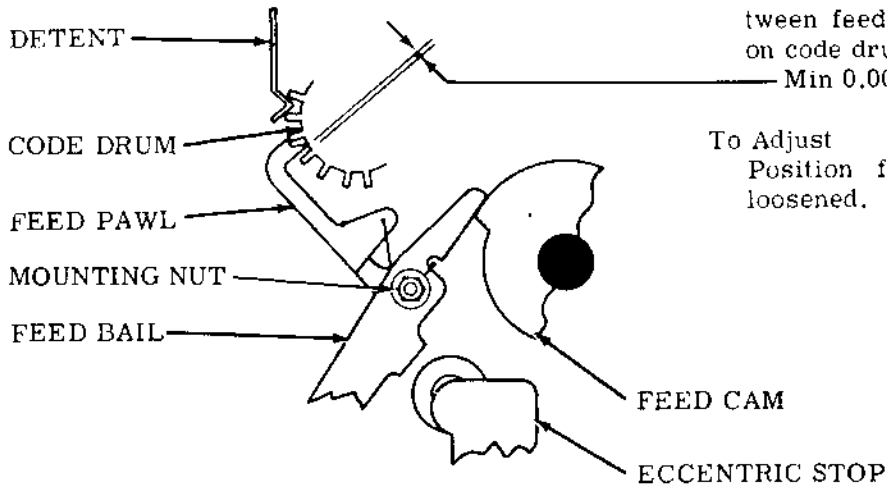

(Left Side View)

FEED PAWL

Requirement  
 Answer-back in stop position, clearance between feed pawl engaging surface and tooth on code drum.  
 Min 0.005 inch---Max 0.015 inch

To Adjust  
 Position feed pawl with its mounting nut loosened. Tighten nut and recheck.

2.04 Feed Mechanism (continued)

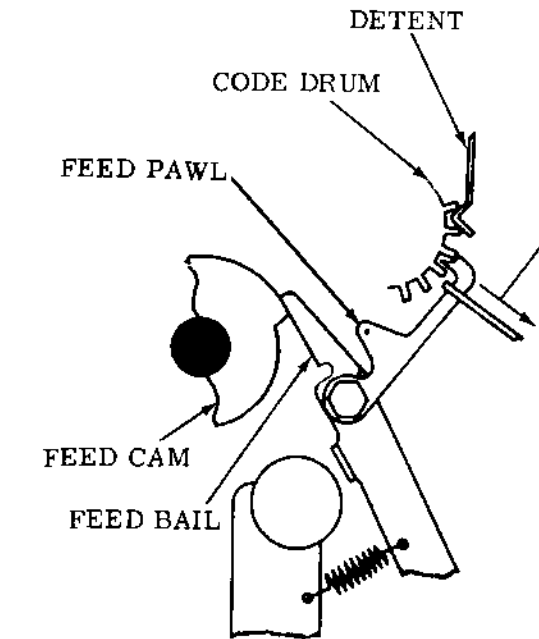

(Right Side View)

FEED PAWL SPRING

Requirement

With answer-back in stop position and code drum in place  
 Min 1/2 oz---Max 1-1/2 oz  
 to start pawl moving.

ECCENTRIC STOP POSITION

Requirement

With feed bail in lowest position of its travel opposite low part of its cam resting on eccentric stop, clearance between feed cam and feed bail.

Min 0.055 inch---Max 0.075 inch

To Adjust

Rotate eccentric with its mounting screw loosened. Tighten screw.

Note: Keep high part of eccentric away from pivot point of feed bail to insure that eccentric stop bears against flat surface of bail extension and not on its lower edge.

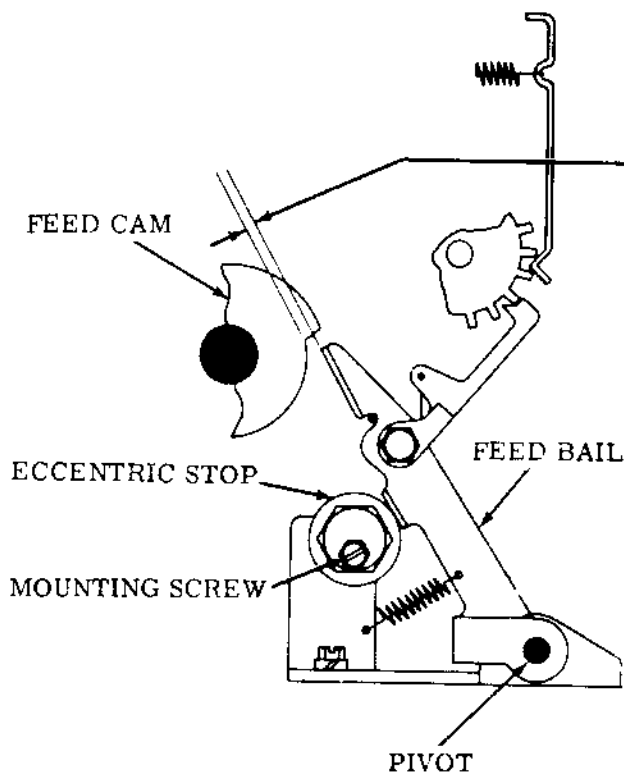

(Right Side View)

2.05 Feed Mechanism (continued)

CODE DRUM CONTACT WIRE SPRING

Requirement  
 Min 1 oz---Max 2 oz  
 to start contact wire moving away from  
 common terminal.

CODE DRUM DETENT SPRING

Requirement  
 Min 9 oz---Max 11 oz  
 to start detent moving.

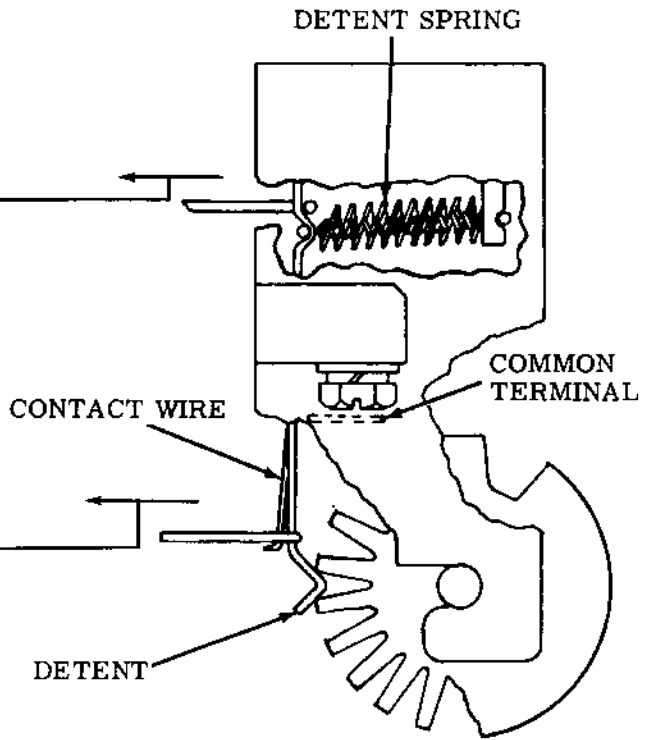

(Left Side View)

2.06 Relay Brackets and Contacts

MOTOR HOLD AND RELAY PULL-UP CONTACT BRACKET

Requirement  
 Trip magnet armature released clearance  
 between insulator on contact and armature  
 Min 0.015 inch---Max 0.030 inch

To Adjust  
 Position contact bracket with its mounting  
 screws loosened. Tighten screws.

Note: Keep bottom bracket parallel with  
 armature pivot axis.

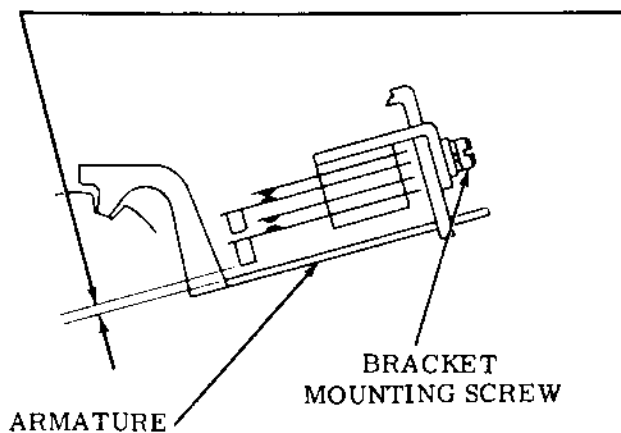

(Left Side View)

## 2.07 Relay Brackets and Contacts (continued)

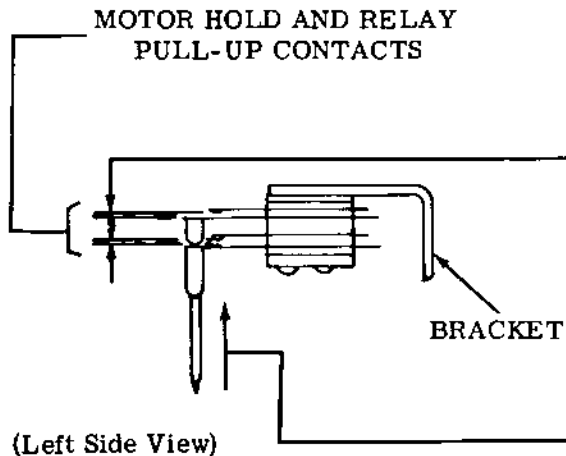
MOTOR HOLD AND RELAY PULL-UP CONTACT

Note: The adjustments are made before installation into the unit and should be checked or remade only in case of malfunction attributed to maladjustment of the contacts. If it should become necessary to remake the adjustment, the following procedure should be followed. Remove contact assembly with bracket from magnet yoke.

- (1) Requirement  
The gap between the contacts in the unoperated position should be  
Min 0.020 inch---Max 0.030 inch
- (2) Requirement  
Min 25 grams---Max 50 grams  
to close both contacts.

To Adjust

Bend contacts to meet requirements.

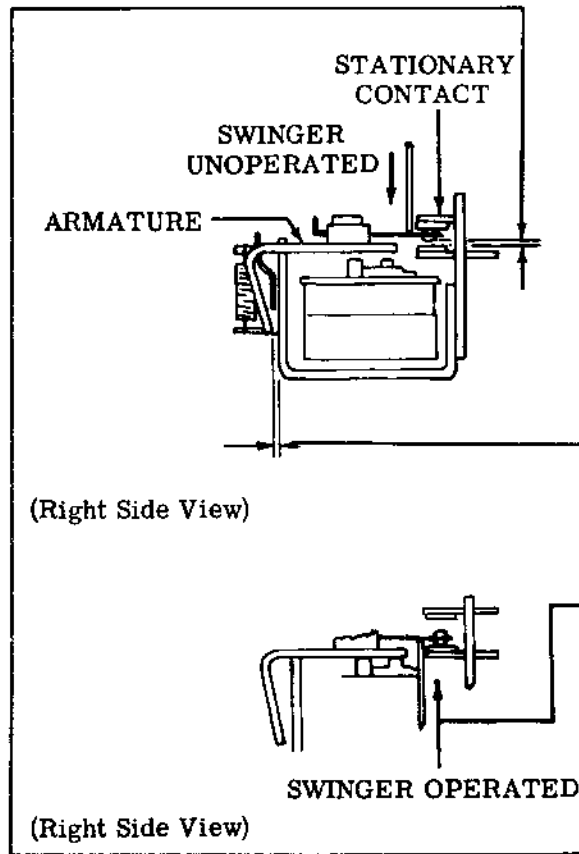
NONREPEAT RELAY

Note: These adjustments are made before installation into the unit and should be checked or remade only in case of malfunction attributed to maladjustment. If it should become necessary to remake the adjustment, the following procedure should be followed:

- (1) Requirement  
With armature released, clearance between armature stops and frame  
Min 0.015 inch---Max 0.025 inch
- (2) Requirement  
The make contact (double) should close a minimum of 0.003 inch before the break (single) contact opens.
- (3) Requirement  
Minimum of 15 grams to move the swinger away from the stationary contacts when the armature is in either the operated or unoperated position.
- (4) Requirement  
The minimum contact gap should be 0.012 inch.

To Adjust

Bend armature stops, stationary contacts, and contact springs to meet requirements.

2.08 Distributor Brushes

DISTRIBUTOR BRUSH HOLDER

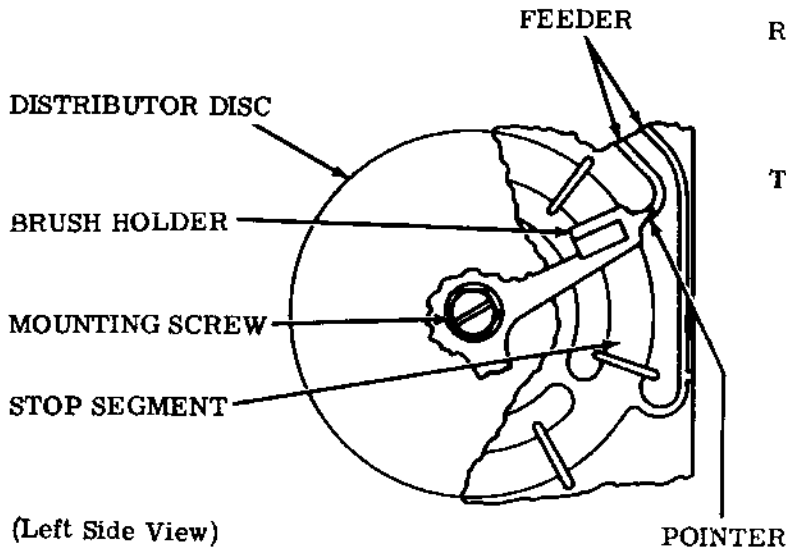

Requirement

With answer-back in stop position, the pointer on the brush holder should point to the feeder of the stop segment.

To Adjust

Turn brush holder clockwise with its mounting screw loosened. Tighten screw.

**CAUTION: DO NOT TURN BRUSH HOLDER COUNTERCLOCKWISE. DAMAGE TO BRUSHES MAY RESULT.**

(Left Side View)

BRUSH HOLDER SPRING

Requirement

New brush

Min 10-1/2 oz---Max 13-1/2 oz

Brush worn to 1/4 inch length

Min 7-1/2 oz---Max 10-1/2 oz

to start outer brush spring moving.

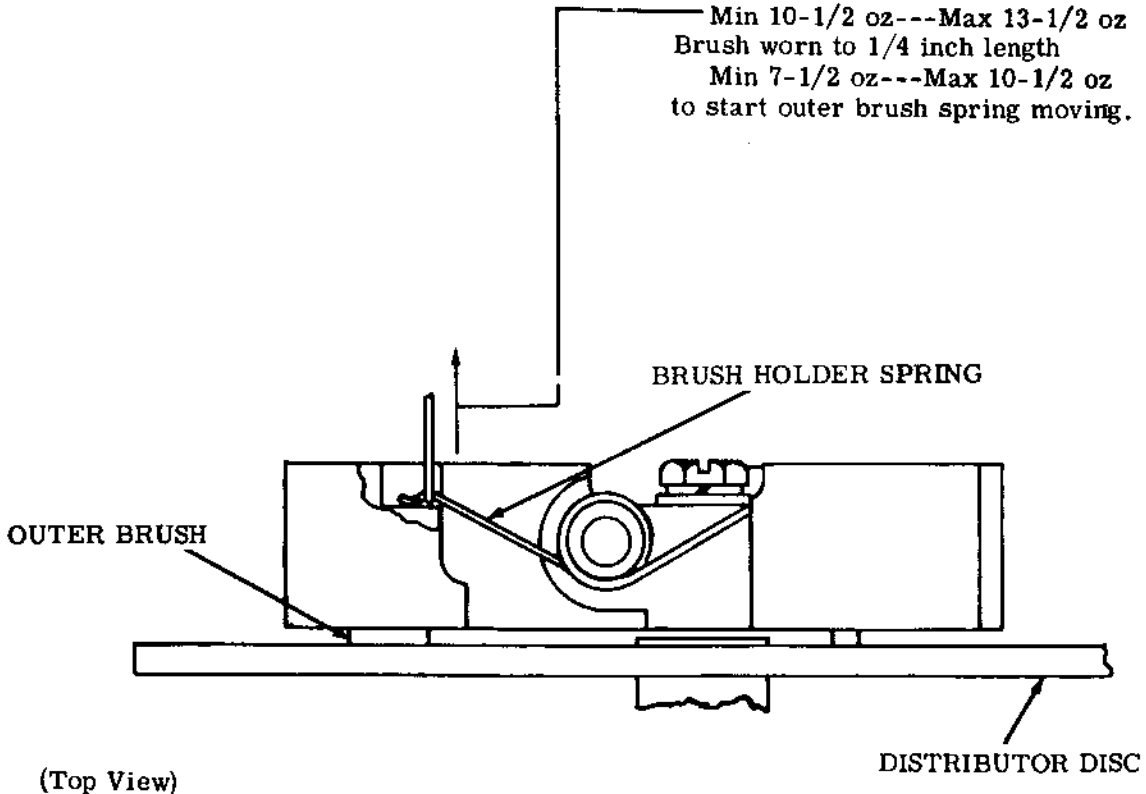

(Top View)

2.09 Gear Backlash

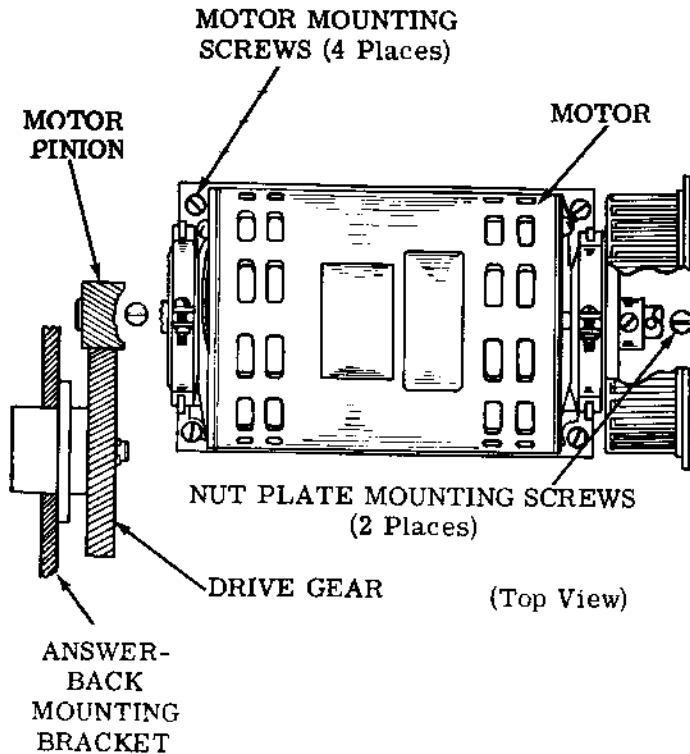

GEAR BACKLASH — SELF-CONTAINED UNIT

(1) Requirement  
Backlash between motor pinion and drive gear should be  
Min 0.004 inch---Max 0.008 inch

(2) Requirement  
Adjust for minimum noise.

To Adjust  
With motor mounting and nut plate screws friction tight, position motor until requirements are met. Tighten motor screws and nut plate screws.

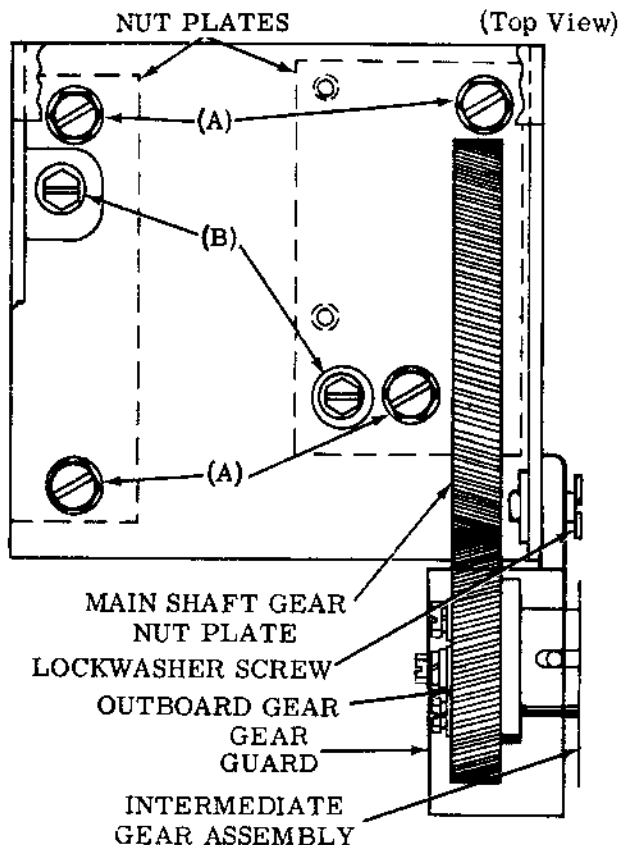

Note: The following adjustment is made after intermediate gear assembly to typing unit gear and motor pinion gear adjustments have been made.

GEAR BACKLASH — RO, KSR

Requirement  
Backlash, at point of minimum clearance between answer-back main shaft gear and outboard gear of intermediate gear assembly on base  
Min 0.004 inch---Max 0.008 inch gauge by feel.

To Adjust  
With two nut plate screws (B) friction tight, loosen four answer-back mounting screws (A). Move answer-back all the way toward front in mounting holes. Tighten four answer-back mounting screws to friction tight and loosen two nut plate screws. Position assembly. Tighten all screws.

2.10 Gear Backlash (continued)

GEAR BACKLASH — ASR (Transmitter Base)

Requirement

Backlash between idler gear and both the answer-back gear and the motor pinion

Min 0.004 inch---Max 0.008 inch—  
gauge by feel.

To Adjust

With answer-back assembly moved all the way toward front and mounting screws tight, loosen two screws which secure idler gear adjustable bracket to frame and position idler gear to provide the required backlash. Tighten screws. The answer-back assembly may be removed from the base and replaced without remaking the adjustment by taking up all the play in the mounting holes in the same manner.

Note: (For applicable units only.) The mechanical clearance between the multiple wire distributor and the answer-back on the transmitter base is quite critical. The possibility exists of a mechanically produced electrical short circuit if the clutch disc stop lug on the distributor clutch contacts the answer-back distributor card. If this occurs, the fourth and fifth levels will be dropped whenever the answer-back distributor card is in the signal circuit (on-line KT and K modes). Check this clearance before performing the station tests. Trip the distributor solenoid and rotate the fan until the clutch disc stop lug is closest to the answer-back distributor card. There should be a minimum of 0.040 inch between the clutch disc stop-lug and the distributor card. To adjust, loosen the four answer-back mounting screws and move the answer-back away from the distributor clutch to meet requirement. Make sure the gear backlash is not excessive and then tighten the mounting screws.

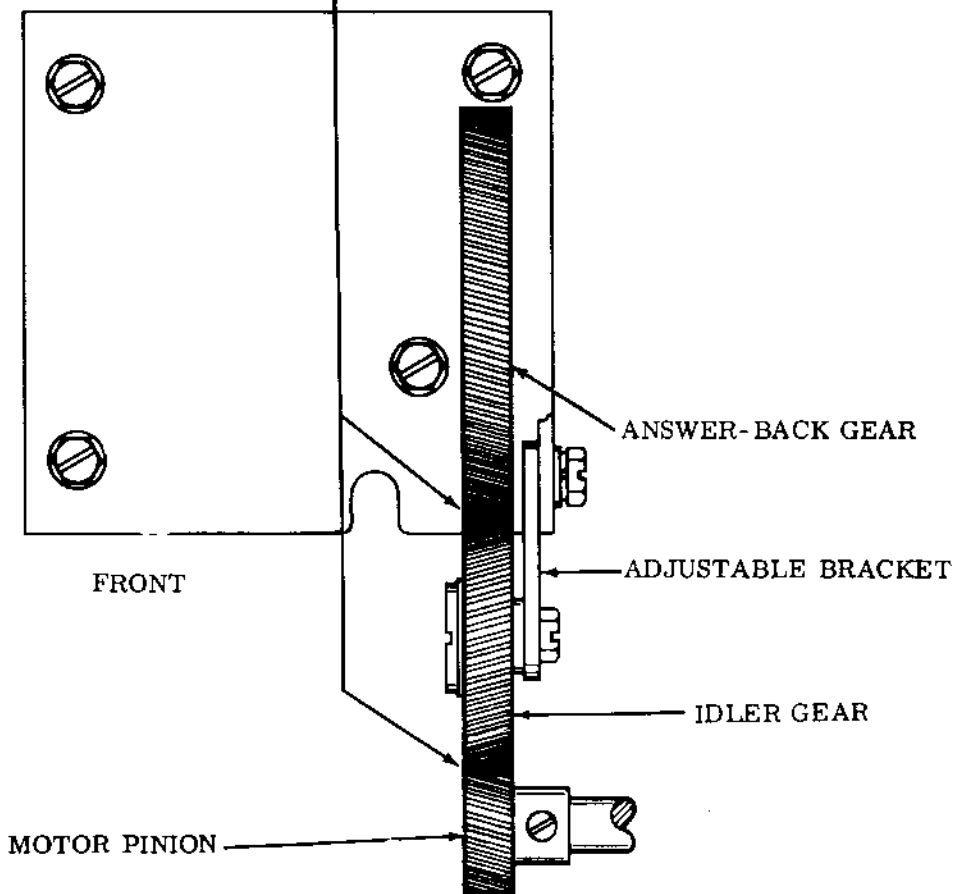

(Top View)

## 2.11 Trip Mechanism (continued)

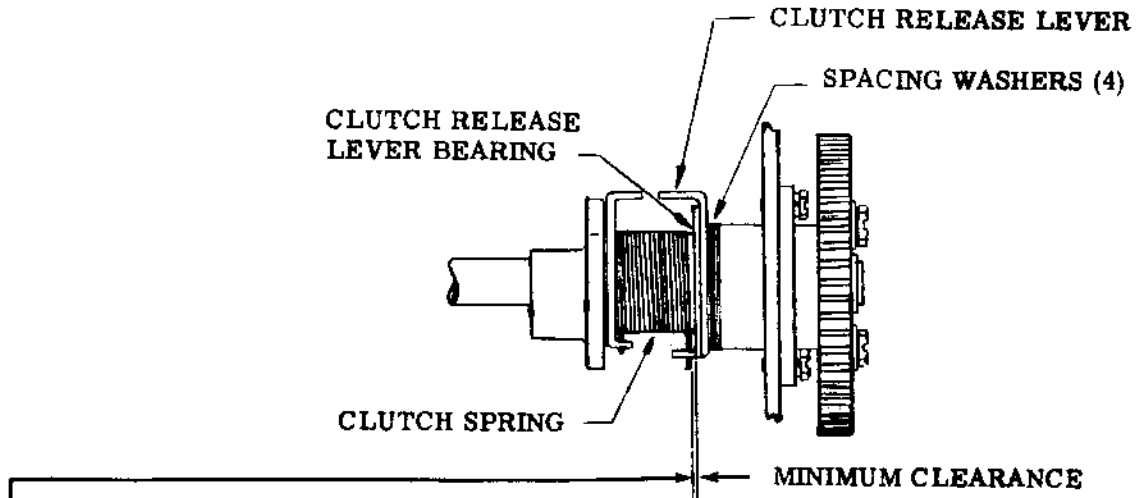

(Front View)

**LATERAL CLUTCH SPRING**

(This adjustment need only be made when the clutch and drive gear assembly has been dismantled.)

**Requirement**

There should be a minimum amount of lateral play between the clutch spring and clutch release lever bearing when all play is taken up.

**To Adjust**

During assembly, add the proper number of spacing washers to meet the requirement. The nominal amount is four. Check assembly to be sure that the clutch spring has no overriding loops when taking up the play.