

BULLETIN 12018

35 SEND-RECEIVE  
and  
RECEIVE-ONLY SETS  
(KSR and RO)

PARTS



**TELETYPE<sup>®</sup>**

**CORPORATION**

5555 TOUHY AVENUE, SKOKIE, ILLINOIS

TABLE OF CONTENTS

SECTION	TITLE	ISSUE	DATE
574-220-800TC	35 Typing Unit (LP)	*6	December 1975
574-221-800TC	35 Send-Receive Keyboard (LK) and Receive-only Base (LB)	4	April 1973
574-226-800TC	35 Electrical Service Unit (LESU) - KSR/RO	4	April 1973
574-226-803TC	35 Electrical Service Unit (LESU) - Wall Mounted KSR/RO	2	December 1968
574-227-800TC	35 Call Control Unit (LCCU)	3	April 1973
574-229-800TC	35 Console and Table Model Cabinet (LAC) - KSR/RO	4	April 1973
574-229-801TC	35 Wall Mounted Cabinet (LPC) - KSR/RO	2	June 1968

Note:

For Motors Refer to Bulletin 295B

\* Indicates revised section

35 TYPING UNIT (LP)  
PARTS

FIGURE	CONTENTS	PAGE	FIGURE	CONTENTS	PAGE
1	Right and Left Side Frames (Wall Mounted)	3	47	152340 Modification Kit to Provide Multi-Copy Paper Handling	49
2	Right Side Frame	4	48	154771 Modification Kit to Provide Vertical Tabulation	50
3	Left Side Frame	5	49	154798 Modification Kit to Provide Superfold Friction Feed Paper Handling	51
4	Pressure Roller Mechanism	6	50	157511 Modification Kit to Provide Local Reverse Line Feed	52
5	Paper Spindle and Reset Bail Mechanism	7	51	194324 Modification Kit to Provide Paper-Out Alarm Switch	53
6	Sprocket Feed Platen Mechanism	8	52	329013 Handwheel Assembly	54
7	Friction Feed Platen and Line Feed Mechanisms	9	53	305035, 305036 & 307065 Modification Kits to Provide Manual Platen Line Feed	54
8	Trip Shaft Mechanism	10	54	163146 Modification Kit to Provide Universal Contact	55
9	Space Suppression Mechanism	11	55	324490 Modification Kit to Provide Paper Jam Alarm	56
10	Vertical Tabulating Mechanism	12	56	305037 Modification Kit to Adapt Sprocket Feed Printers to 9-1/2 Inch Form Widths	57
11	330682 Vertical Tabulation Assembly	13	57	311456, 324095 & 333520 Modification Kits to Provide Paper Jam Alarms	58
12	Contact Assemblies for Vertical Tabulating Mechanism	14	58	312711 Modification Kit to Adapt Units with a Vertical Tabulating Mechanism to use the 179724 Modification Kit	59
13	Main Shaft Mechanism	15	59	311458, 311459, 311460 & 311461 Modification Kits to Add Adjustable Last Form Alarm	60
14	Main Shaft Mechanism (Continued)	16	60	321099 Modification Kit to Provide Automatic Carriage Return and Line Feed	61
15	Right Side Linkage and Type Box Carriage Mechanism	17	61	152350 Modification Kit to Provide Keyboard Lock	62
16	Left Side Linkage and Racker Shaft Mechanism	18	62	157510 Modification Kit to Provide Local Backspace	62
17	Front Plate Mechanism	19	63	305540 Modification Kit to Provide a Yield Mechanism for the Line Feed Stripper Slide (Function Box Slots 39, 40 & 41)	63
18	Front Plate Mechanism (Continued)	20	64	305539 Modification Kit to Provide a Yield Mechanism for the Line Feed Stripper Slide (Function Box Slots 39 & 40)	63
19	Front Plate Mechanism (Continued)	21	65	176420, 176421 Modification Kits to Add Timing Contacts for Selector	64
20	Front Plate Mechanism (Continued)	22	66	163183 Modification Kit to Provide D. C. Magnet Operated Print Suppression	65
21	Front Plate Mechanism (Continued)	23	67	325967 Modification Kit to Convert Sprocket Feed Printer Line Feed from 6.1 to 3.1 Ratio (6 Stop to 3 Stop Clutch)	66
22	Carriage Return and Spacing Drum Mechanism	24	68	329014 Paper Chute Assembly	67
23	Selector Mechanism	25		Numerical Index	68
24	Selector Magnet Timing Contact Mechanism	26			
25	Selector Magnet Mechanism	27			
26	192495 Form-Out Solenoid Assembly	28			
27	Codebar Positioning Mechanism	29			
28	Intermediate Storage Feature for Codebar Positioning Mechanism	30			
29	Low Paper and Paper-Out Alarms	31			
30	Paper Alarms and Form-Out Mechanisms	32			
31	Left Ribbon Feed Mechanism	33			
32	Right Ribbon Feed Mechanism	34			
33	173260 Printing Carriage Mechanism	35			
34	Horizontal Tabulating Mechanism	36			
35	Codebar Mechanism	37			
36	Basic Stunt Box Components	38			
37	Switch Assemblies and Components	39			
38	Function Levers and Pawls	40			
39	Suppression Solenoid Mechanism	41			
40	Function Bars	42			
41	Type Pallet Box and Type Pallet Chart	43			
42	Type Pallet Chart	44			
43	Sprocket Feed Paper Handling Mod Kits	45			
	Vertical Tabulation Modification Kits	46			
	Right Side-Ribbon Feed Mechanism For Two Color Ribbon Printing	47			
46	Left Side-Ribbon Feed Mechanism For Two Color Ribbon Printing	48			

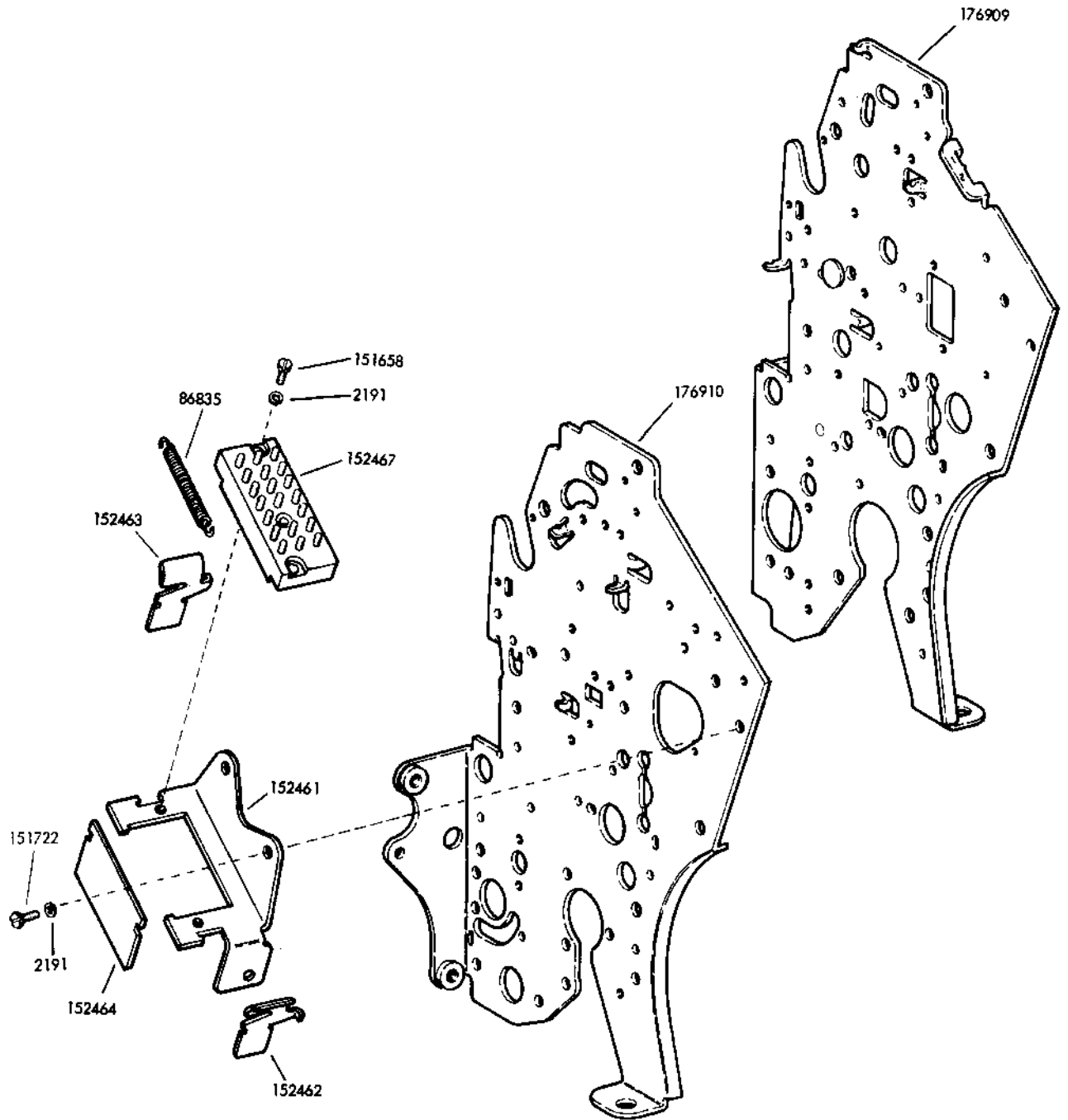

FIGURE 1. RIGHT AND LEFT SIDE FRAMES (WALL MOUNTED)

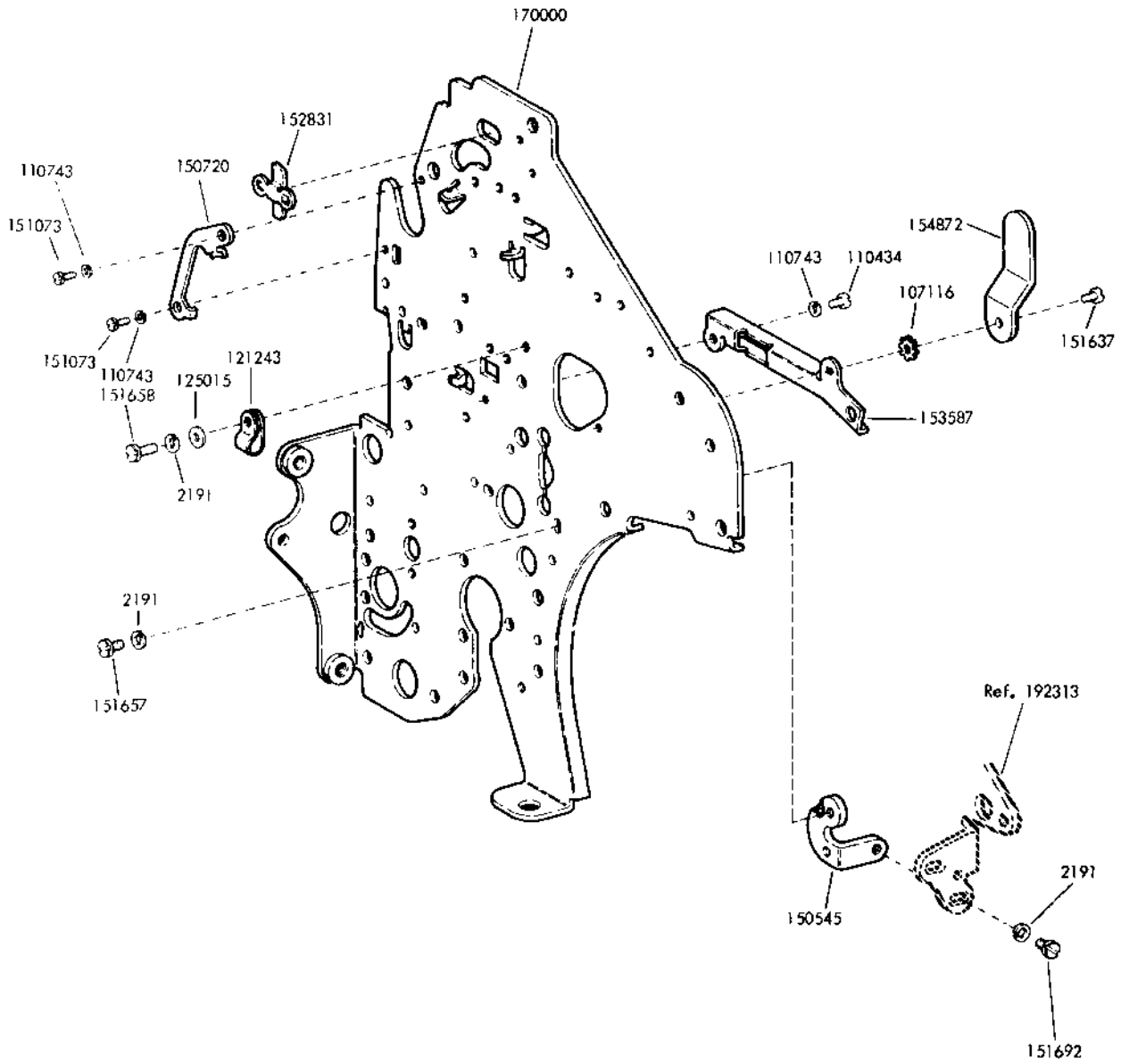

FIGURE 2. RIGHT SIDE FRAME

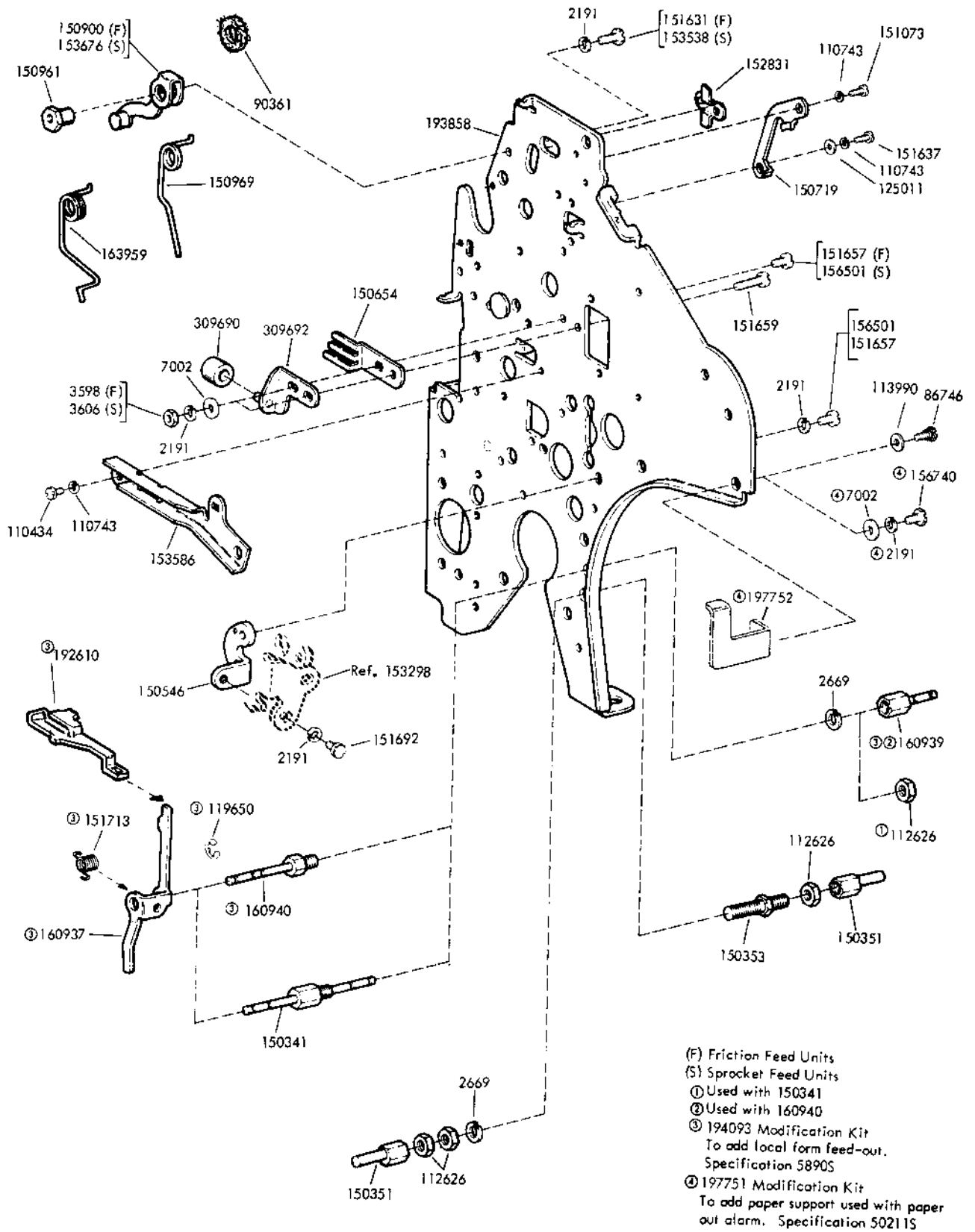

FIGURE 3. LEFT SIDE FRAME

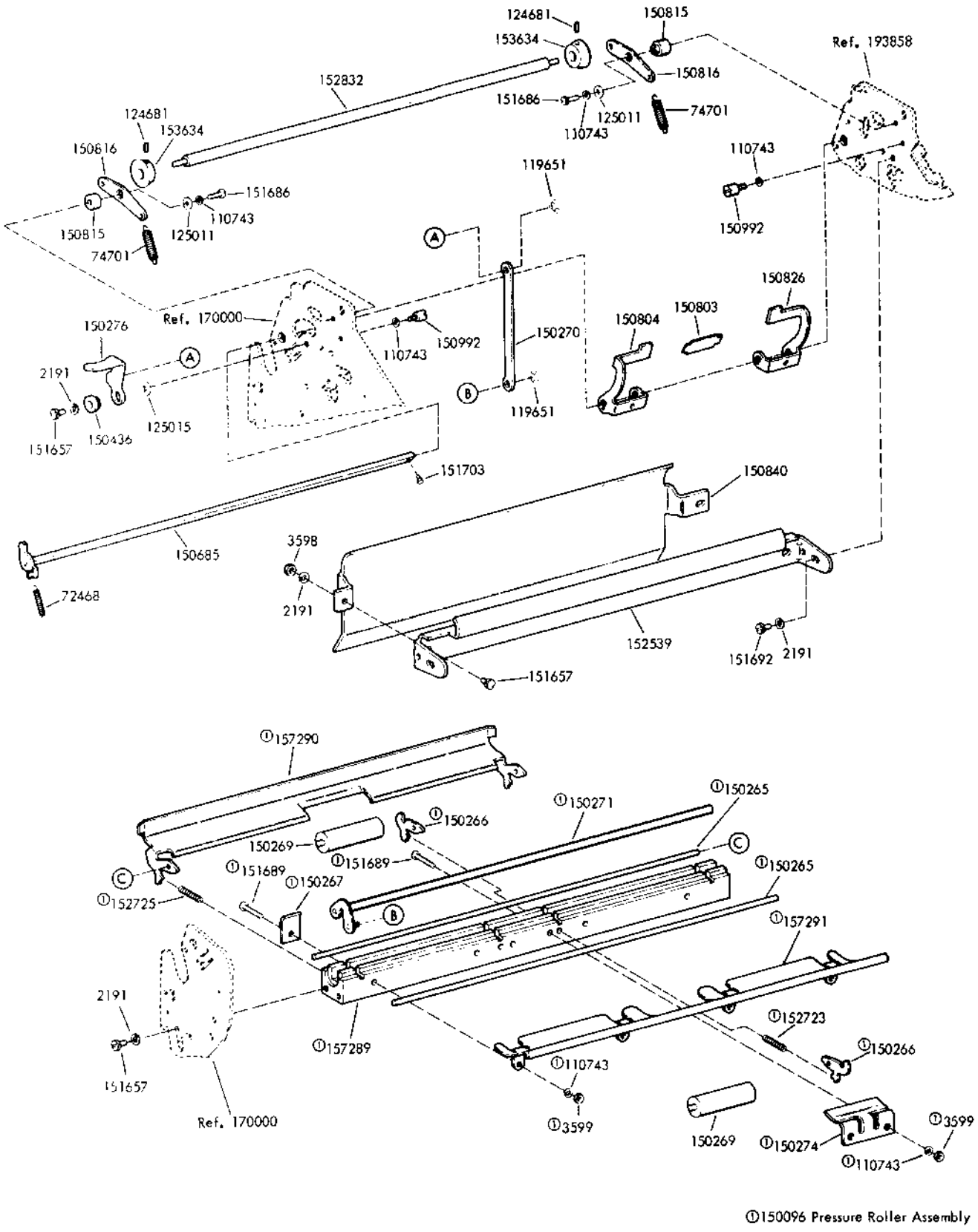

FIGURE 4. PRESSURE ROLLER MECHANISM



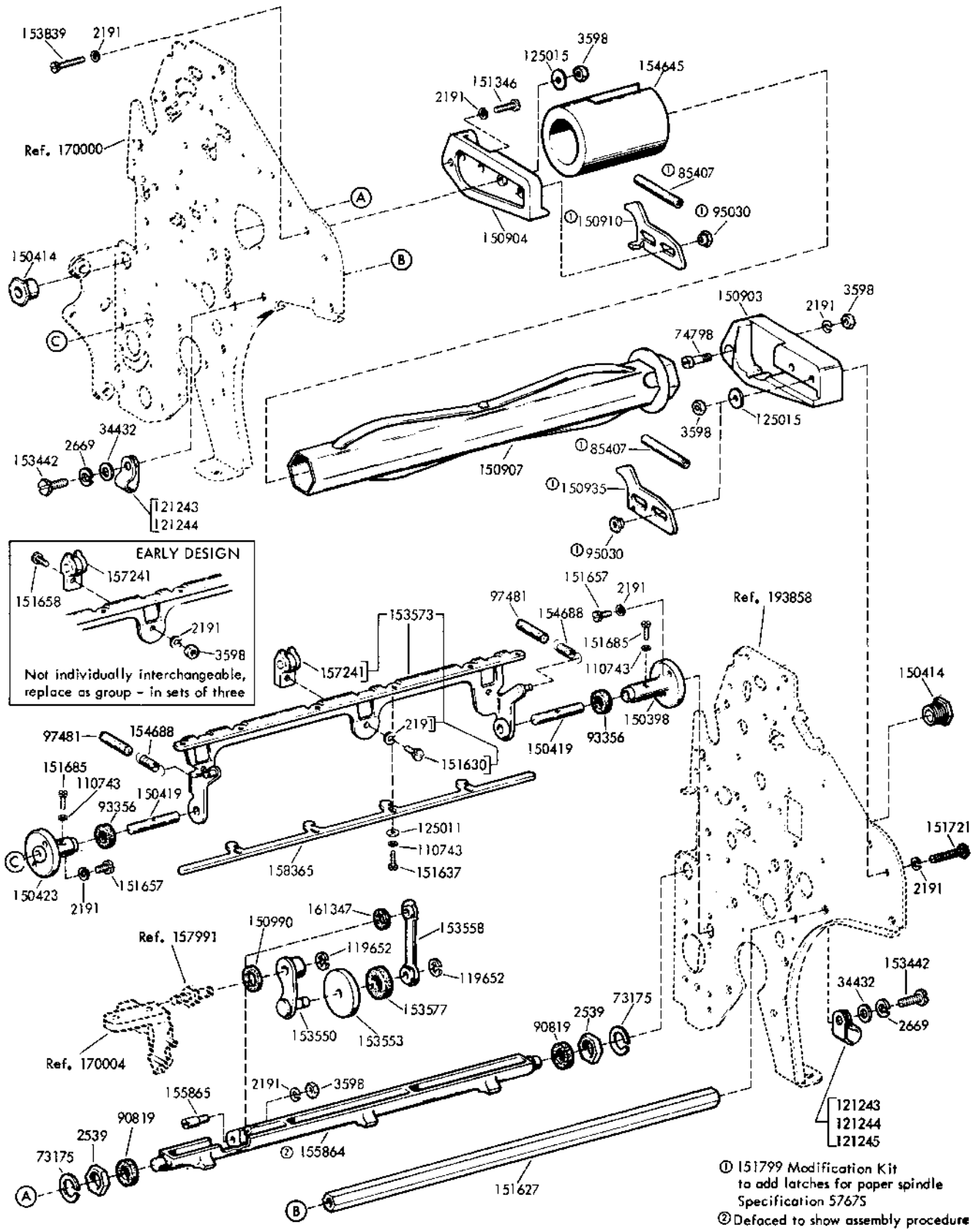

FIGURE 5. PAPER SPINDLE AND RESET BAIL MECHANISM

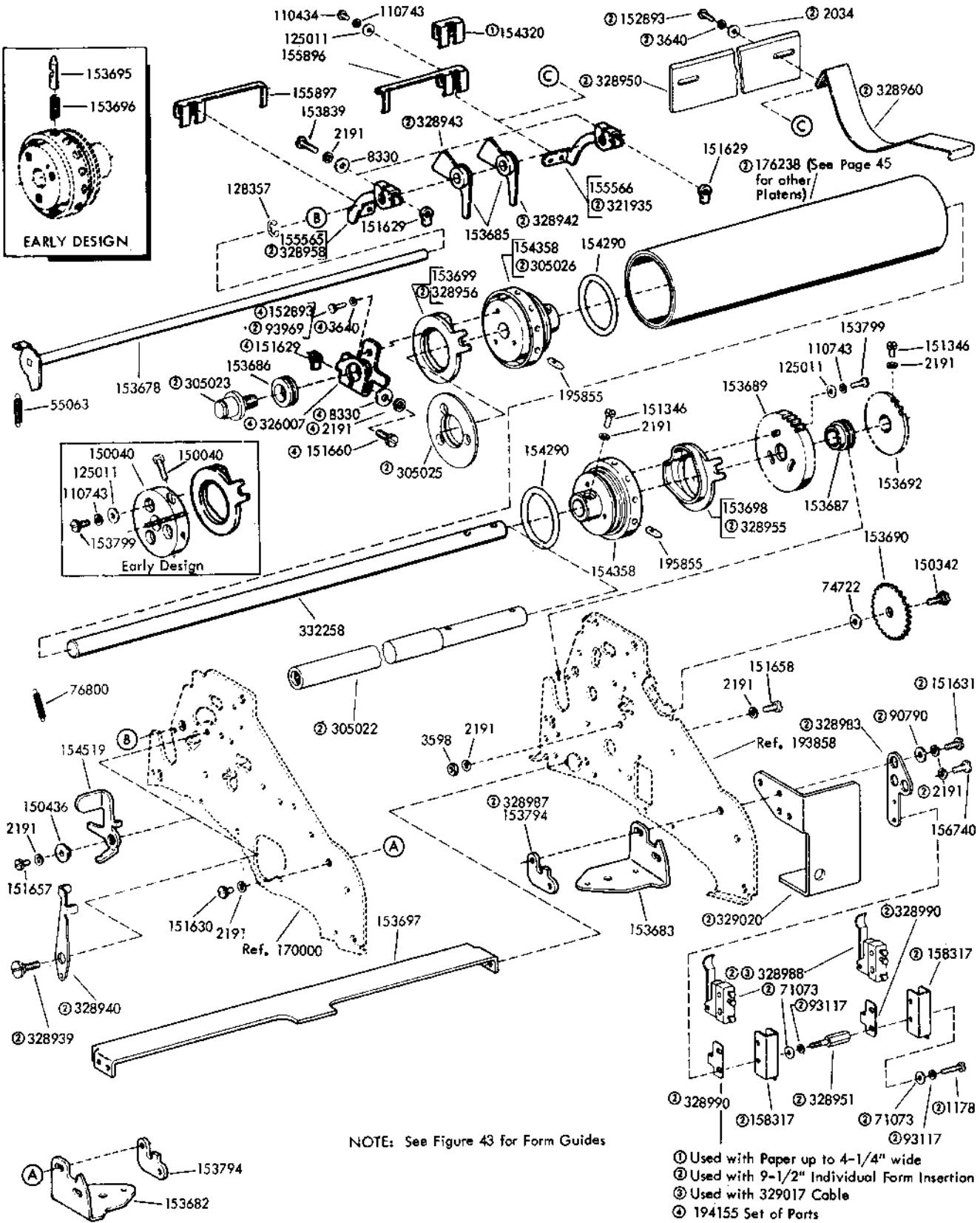

FIGURE 6. SPROCKET FEED PLATEN MECHANISM

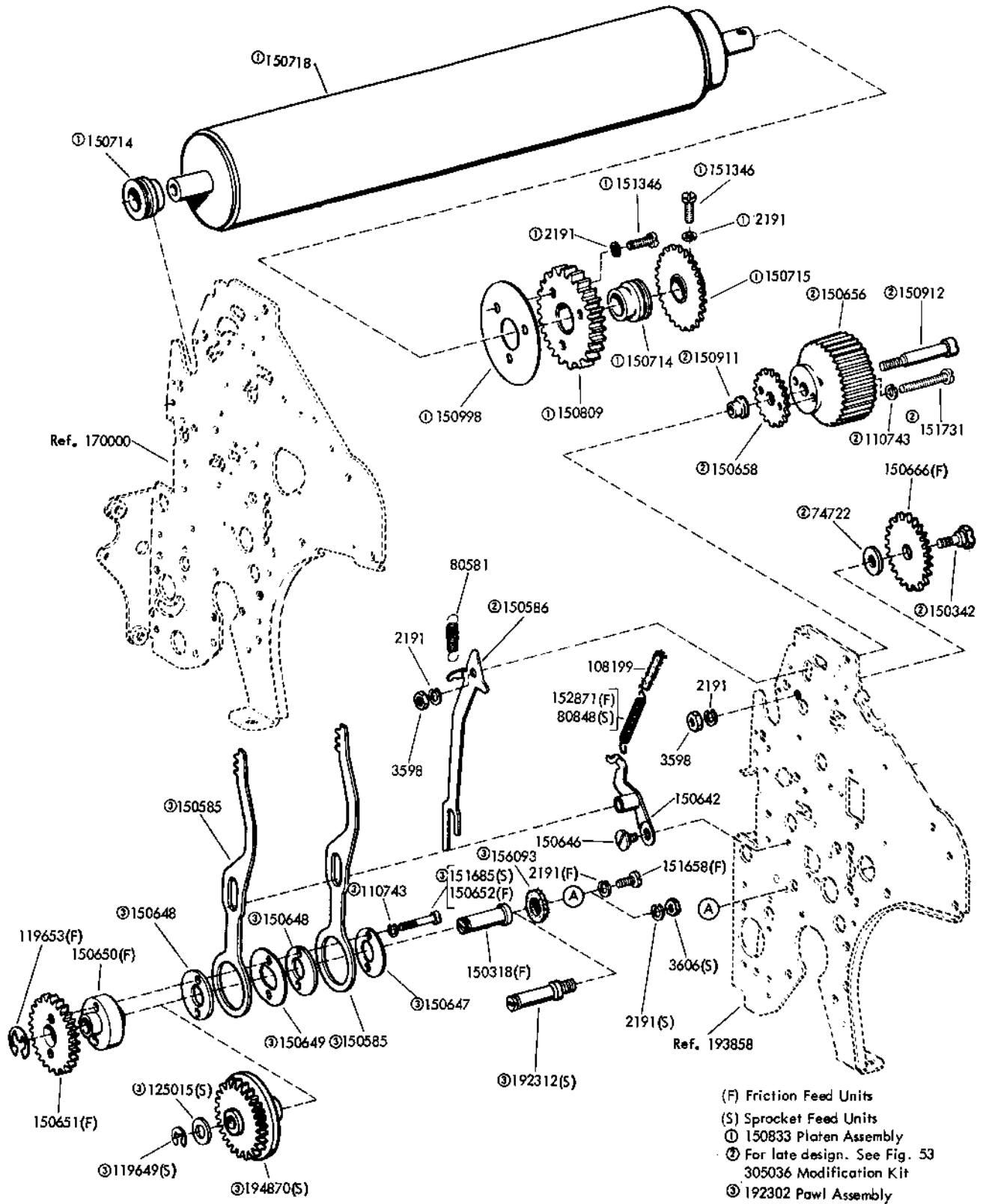

FIGURE 7. FRICTION FEED PLATEN AND LINE FEED MECHANISMS

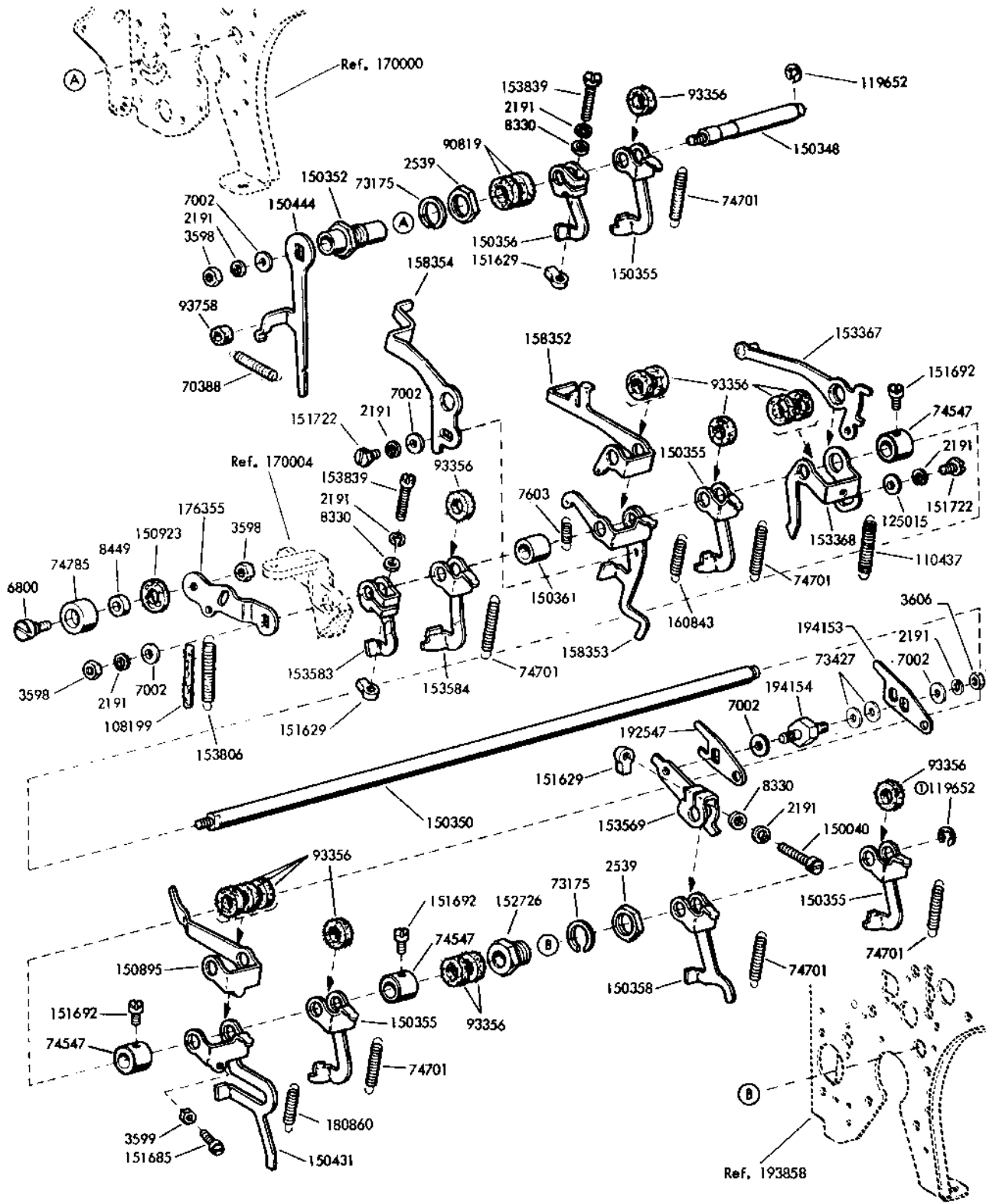

FIGURE 8. TRIP SHAFT MECHANISM

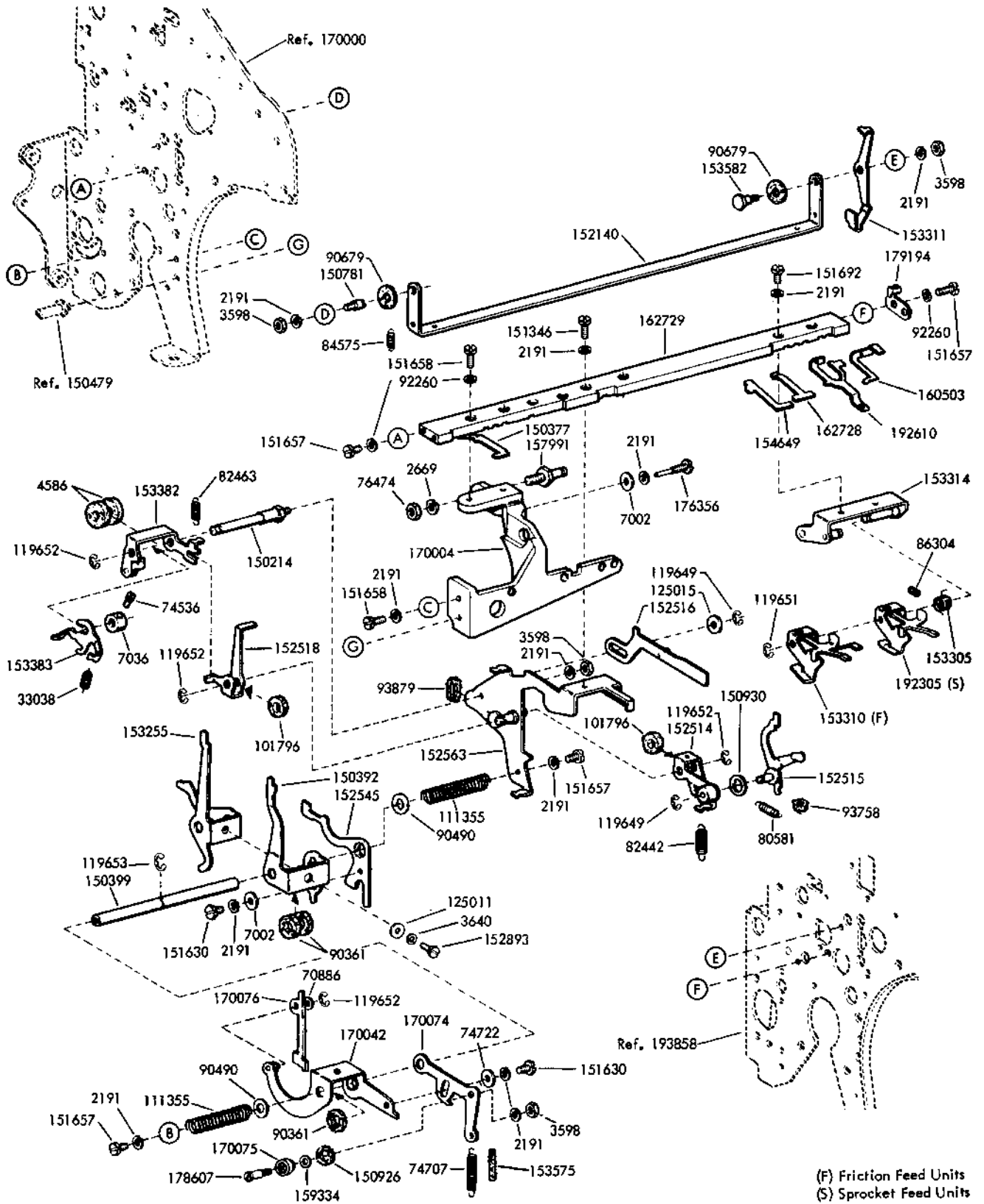

FIGURE 9. SPACE SUPPRESSION MECHANISM

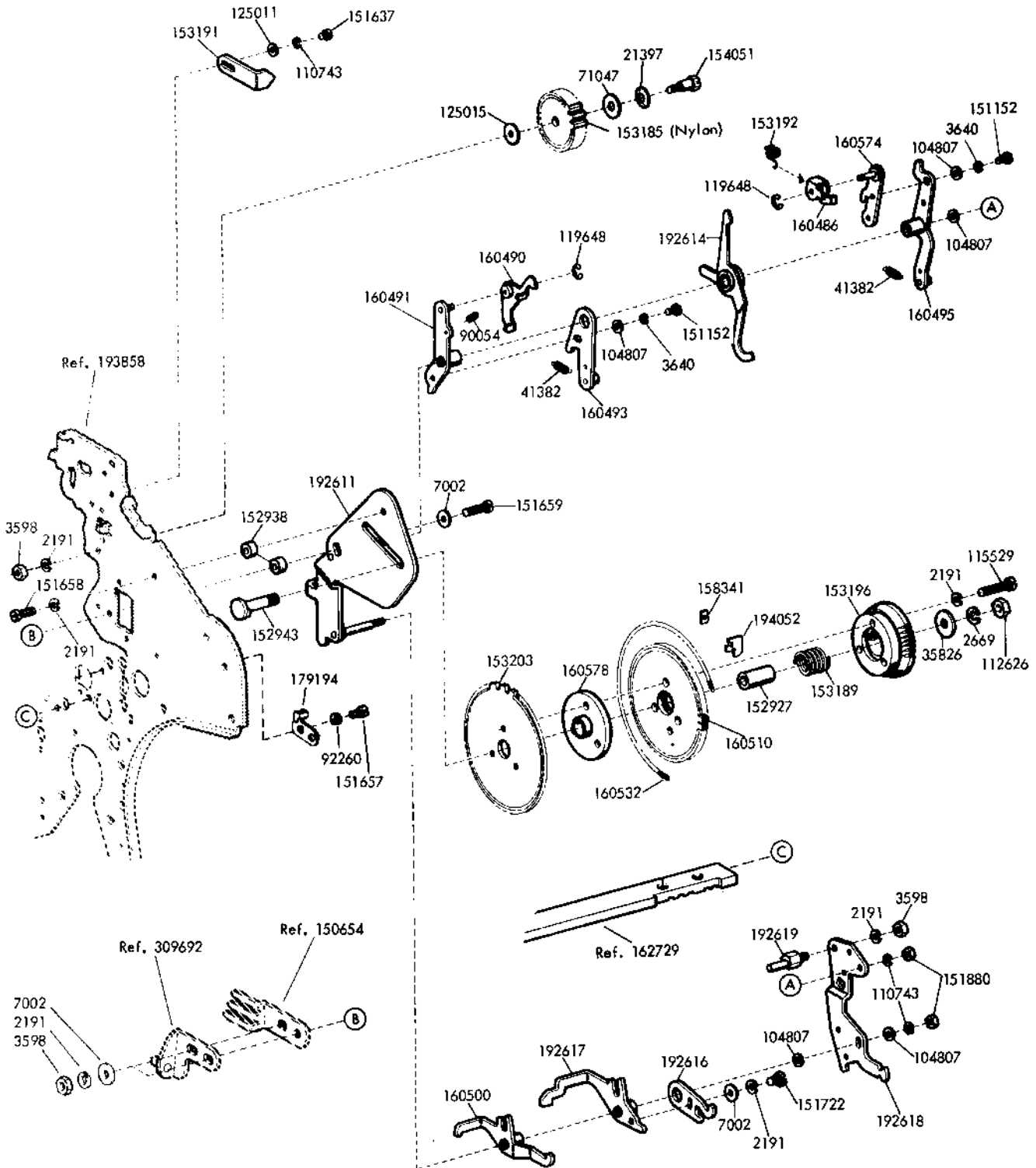

FIGURE 10. VERTICAL TABULATING MECHANISM

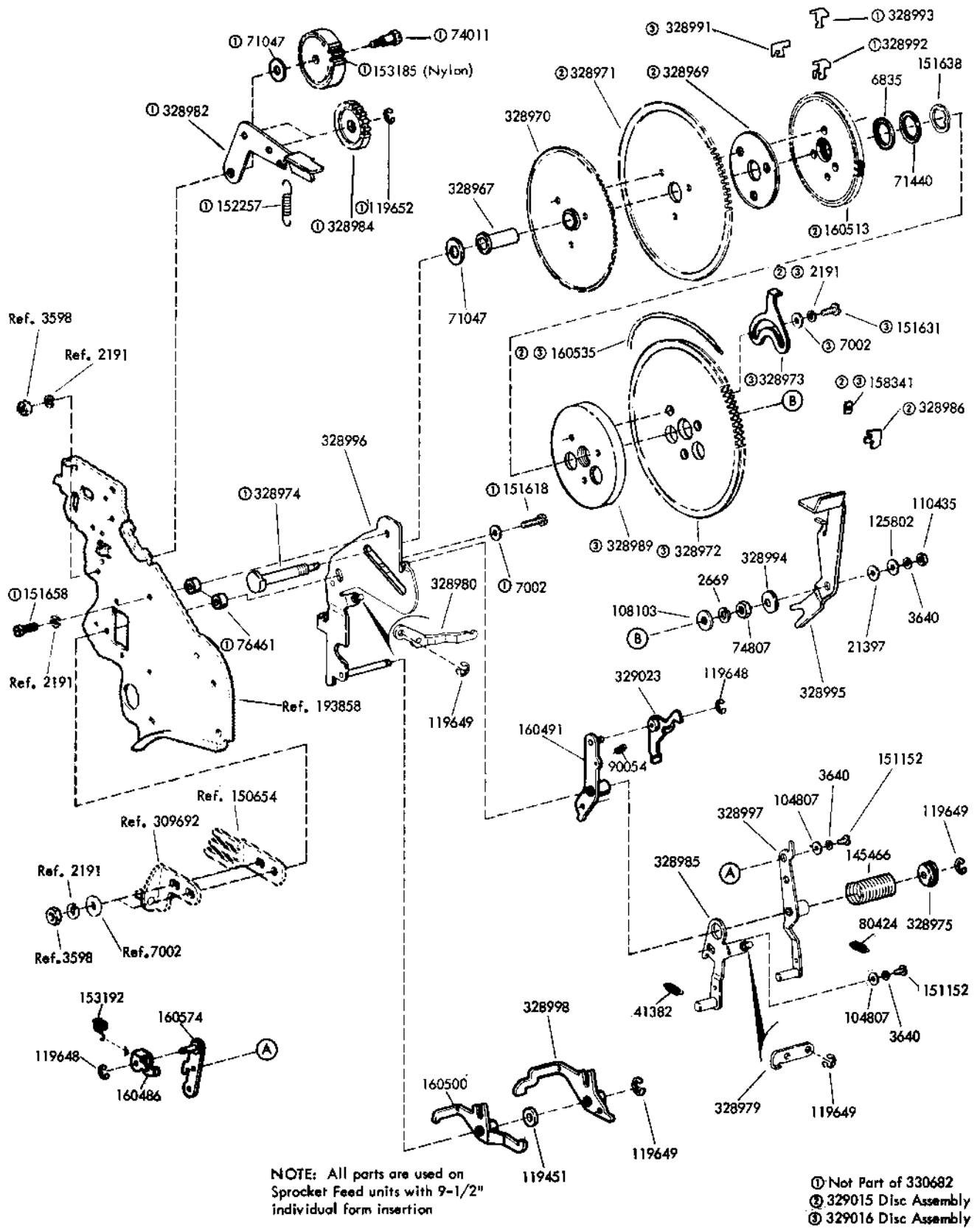

FIGURE 11. 330682 VERTICAL TABULATION ASSEMBLY

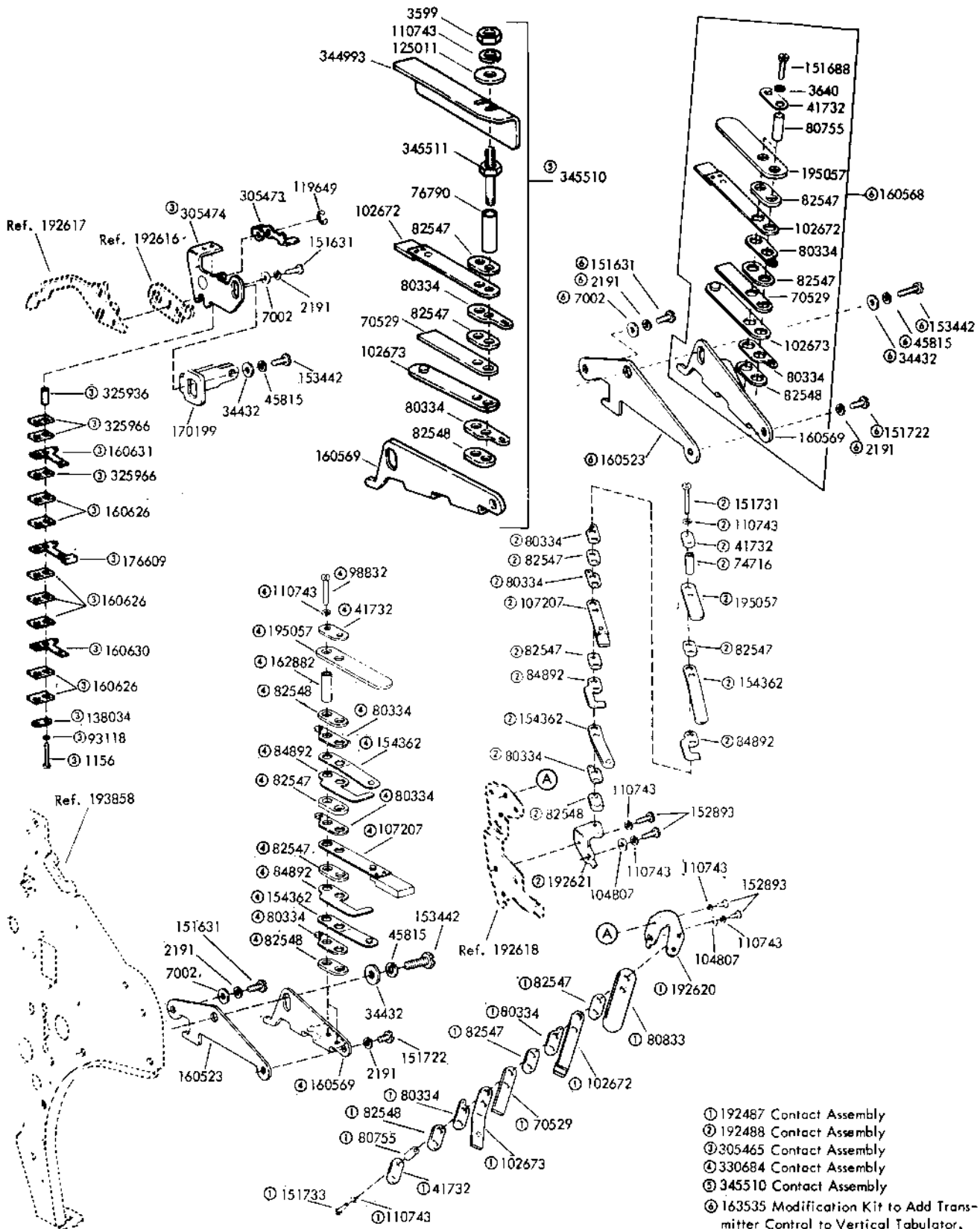

FIGURE 12. CONTACT ASSEMBLIES FOR VERTICAL TABULATING MECHANISM



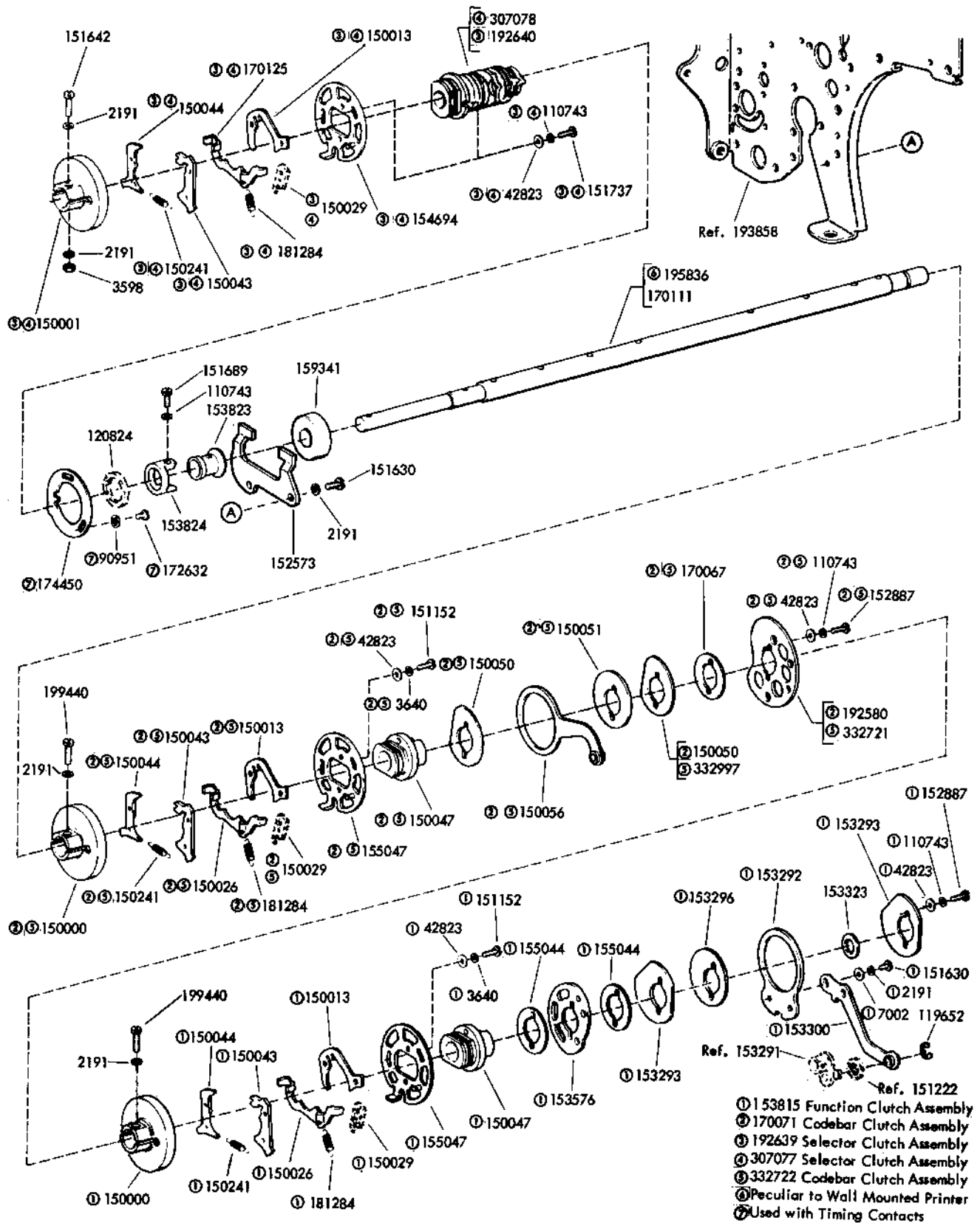

FIGURE 13. MAIN SHAFT MECHANISM

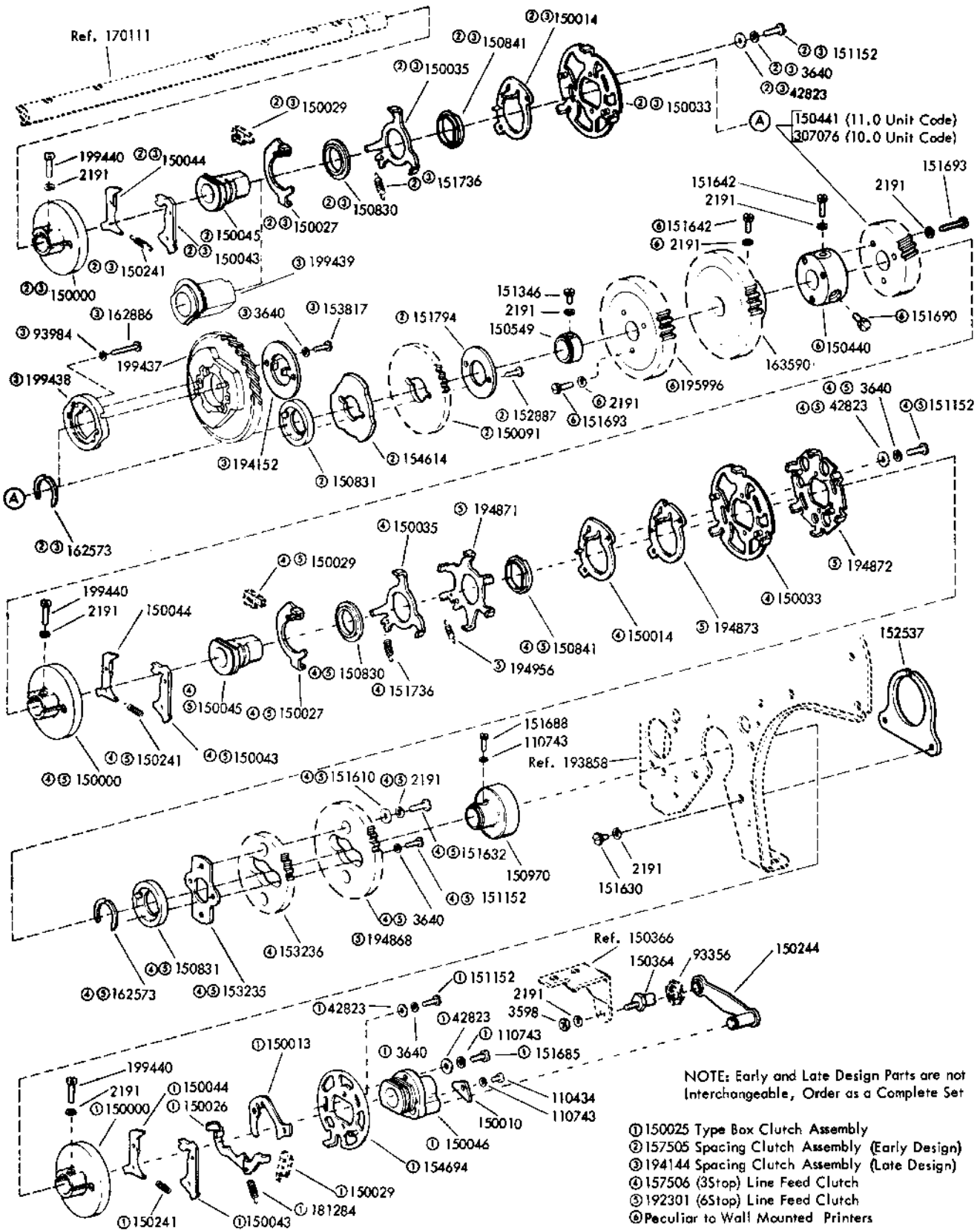

FIGURE 14. MAIN SHAFT MECHANISM (Continued)

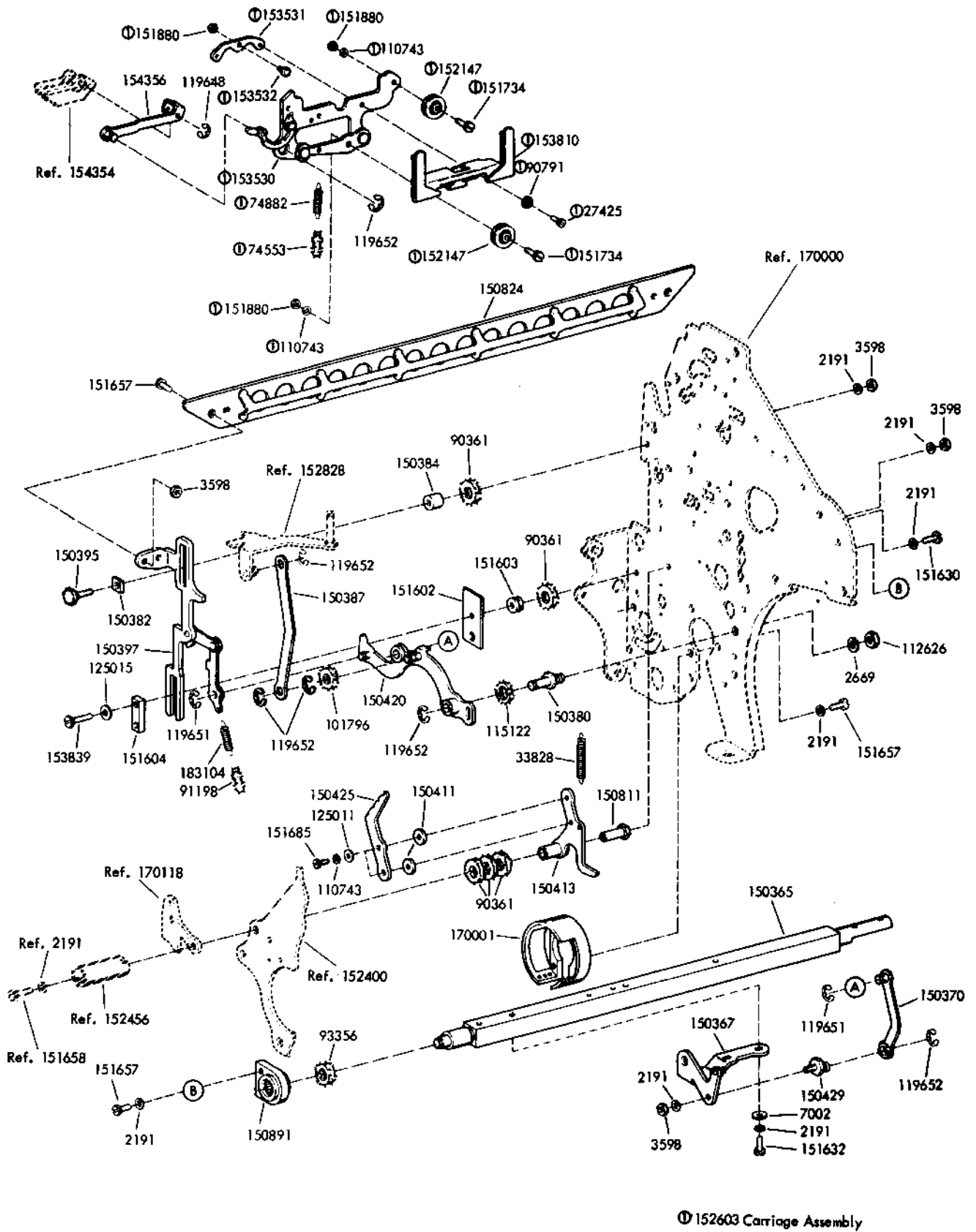

FIGURE 15. RIGHT SIDE LINKAGE AND TYPE BOX CARRIAGE MECHANISM

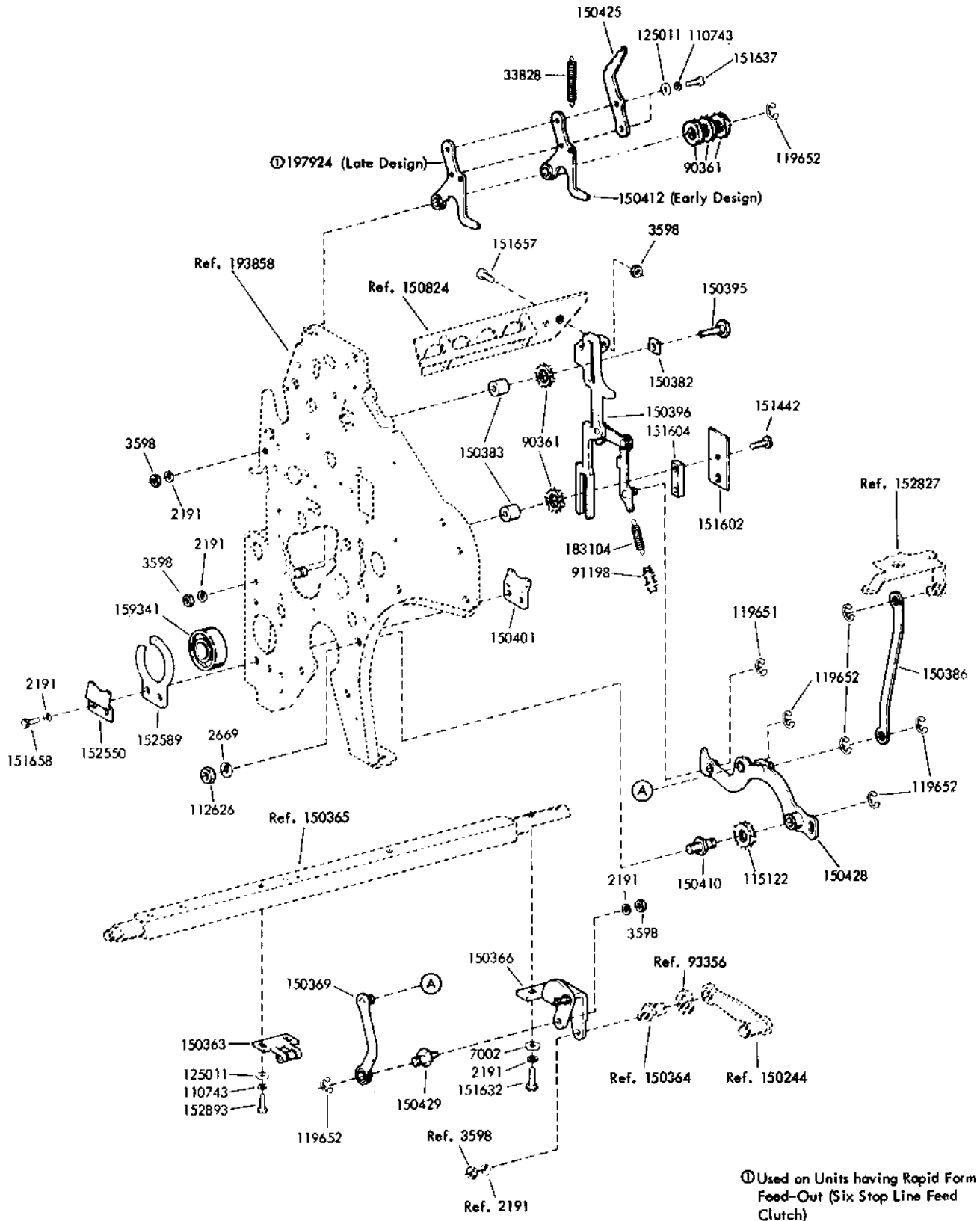

FIGURE 16. LEFT SIDE LINKAGE AND ROCKER SHAFT MECHANISM

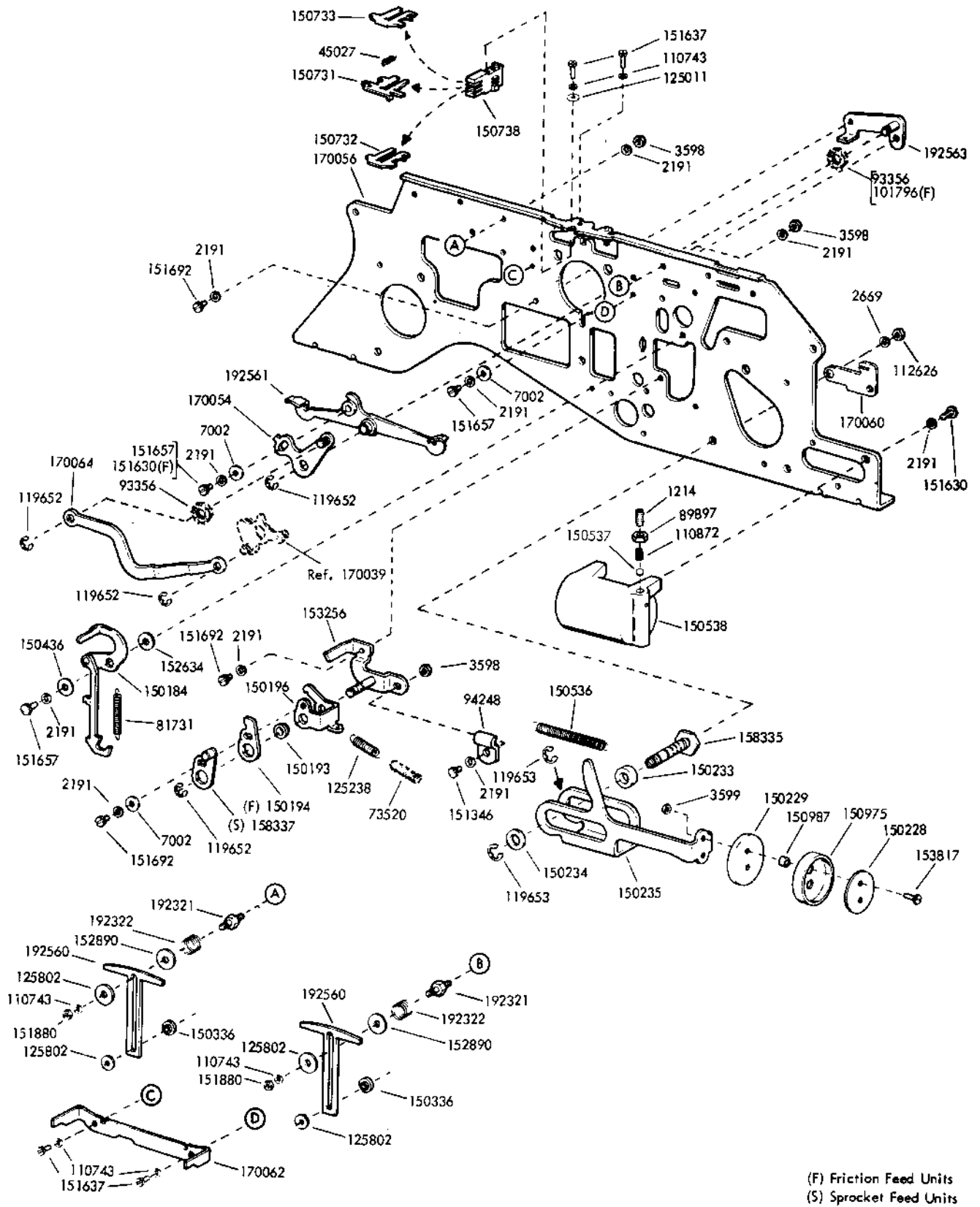

FIGURE 17. FRONT PLATE MECHANISM

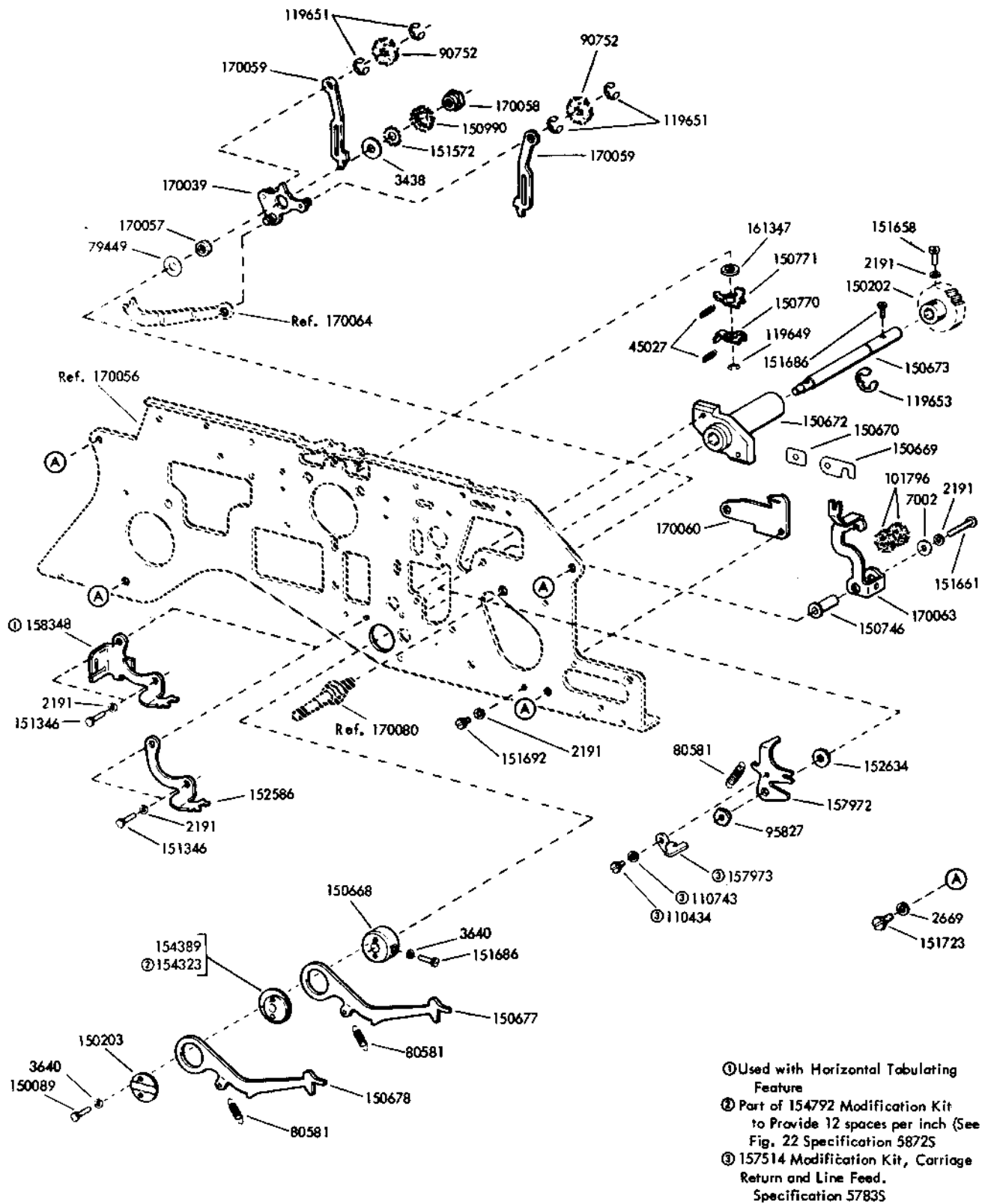

FIGURE 18. FRONT PLATE MECHANISM (Continued)

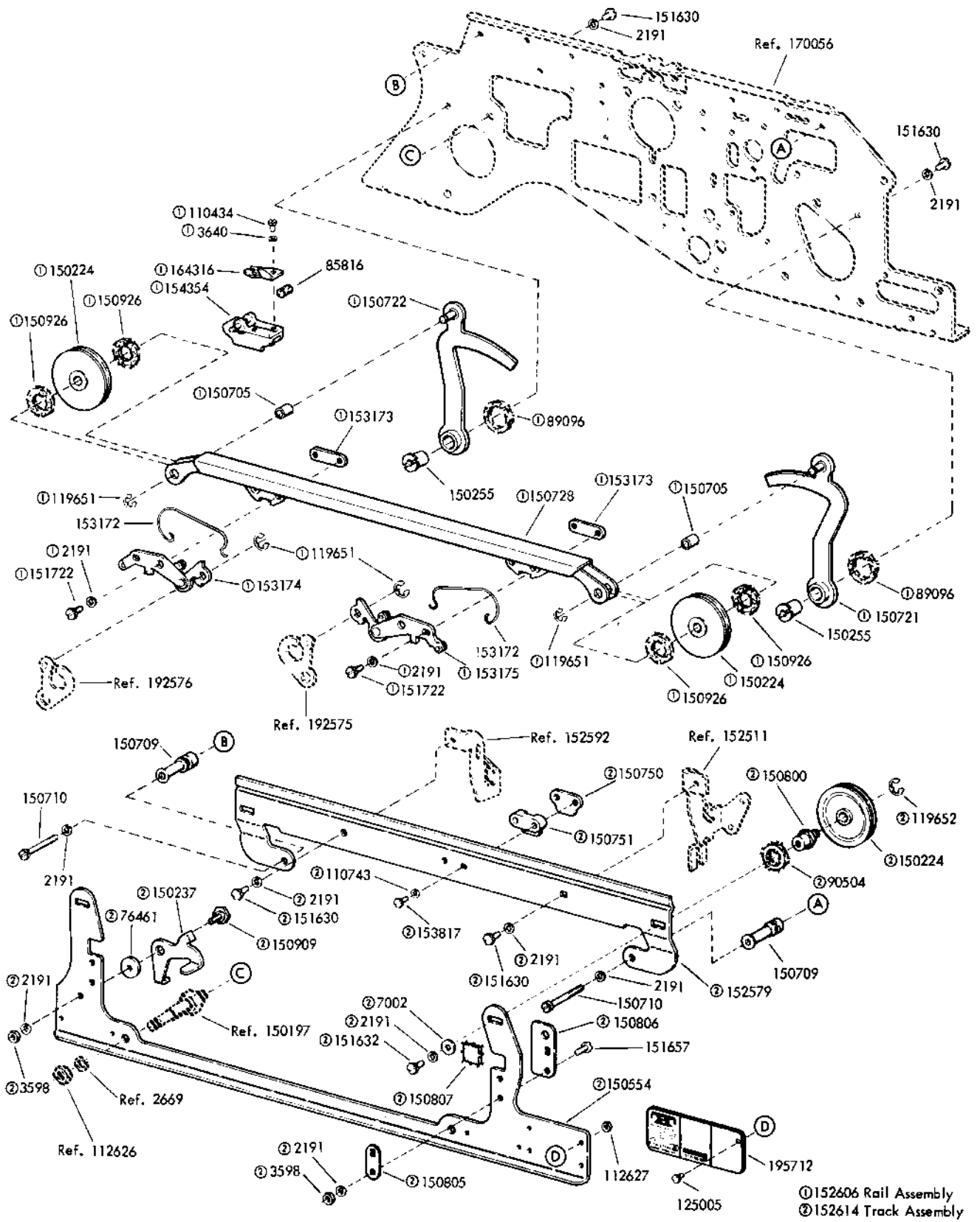

FIGURE 19. FRONT PLATE MECHANISM (Continued)

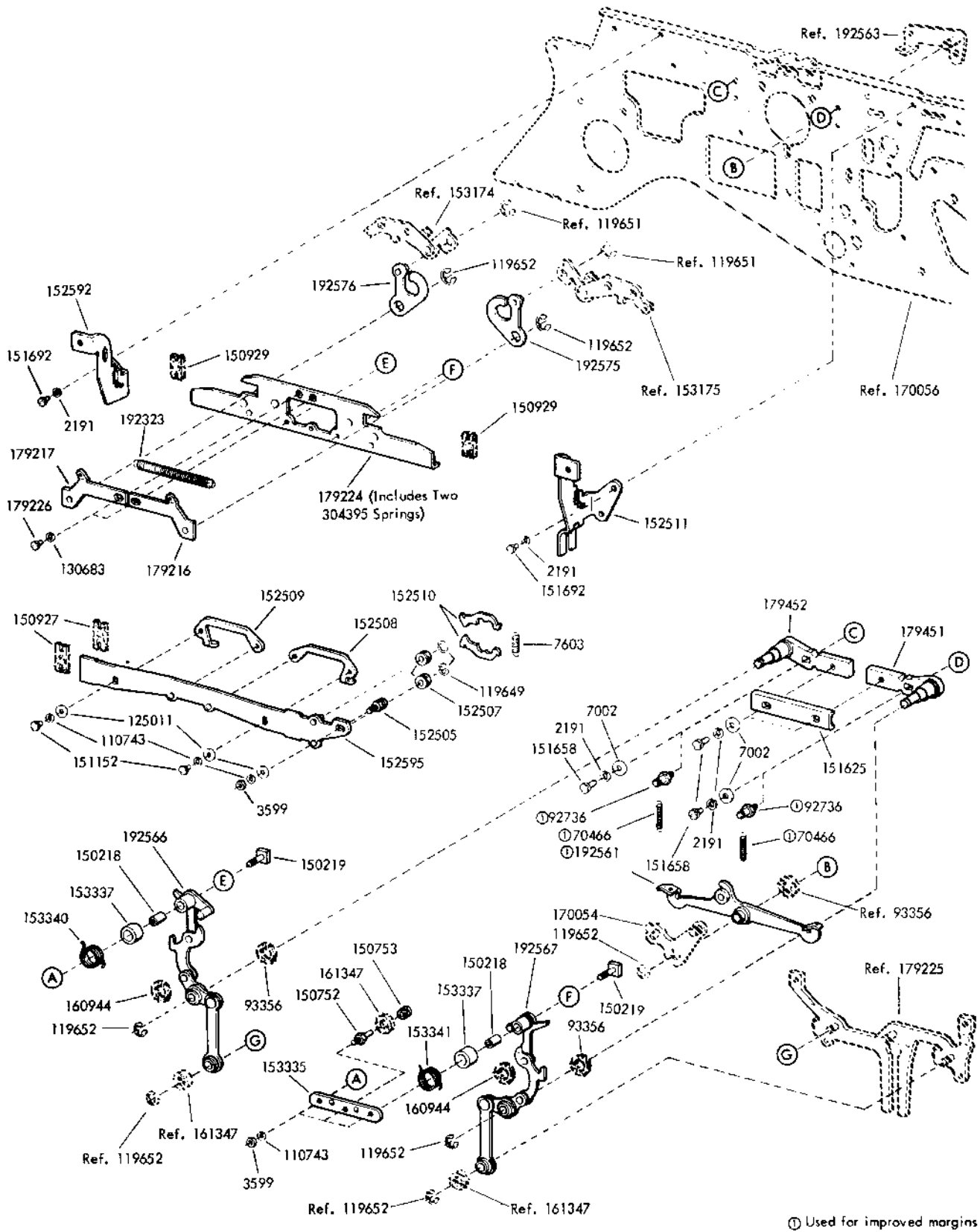

FIGURE 20. FRONT PLATE MECHANISM (Continued)



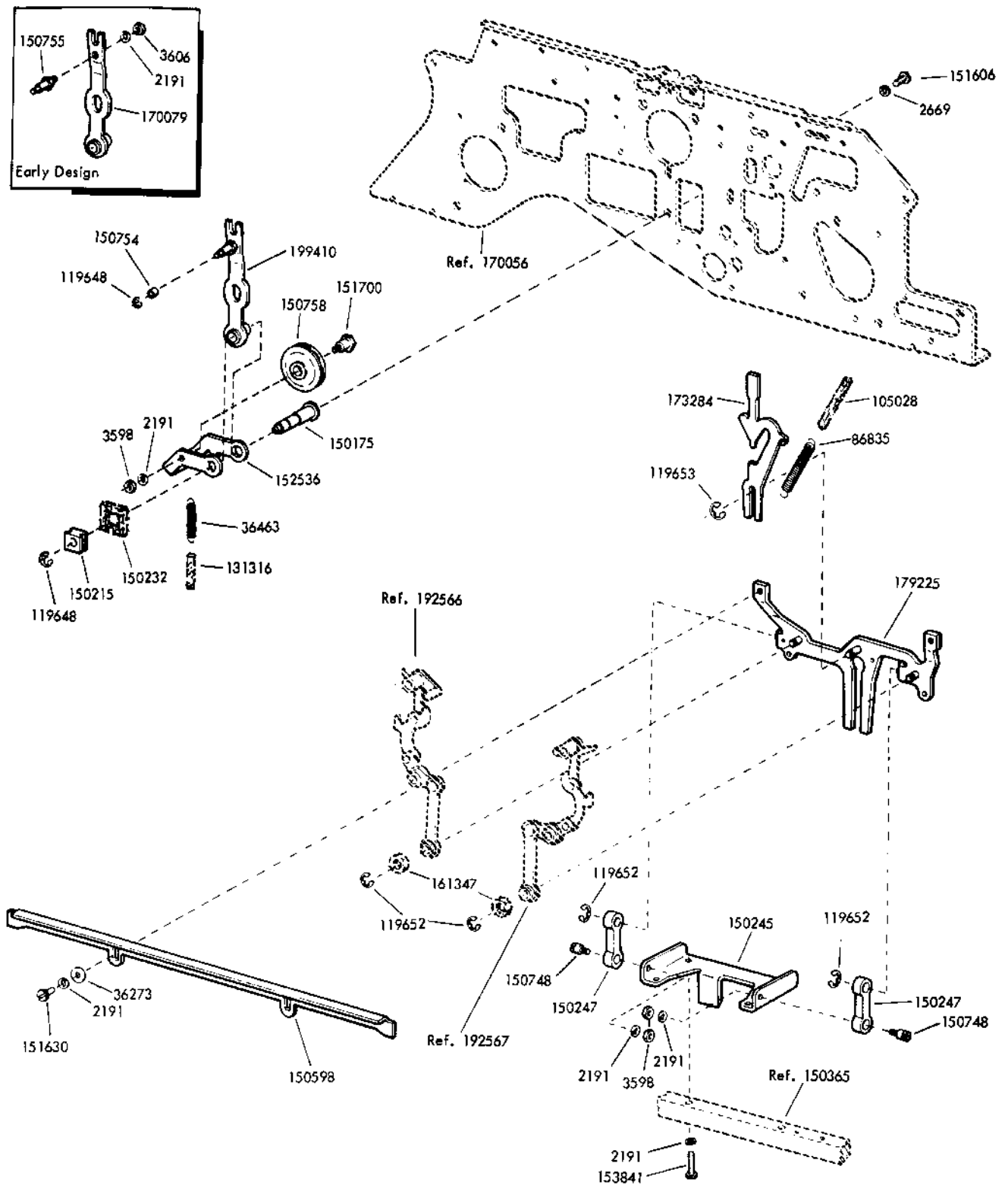

FIGURE 21. FRONT PLATE MECHANISM (Continued)

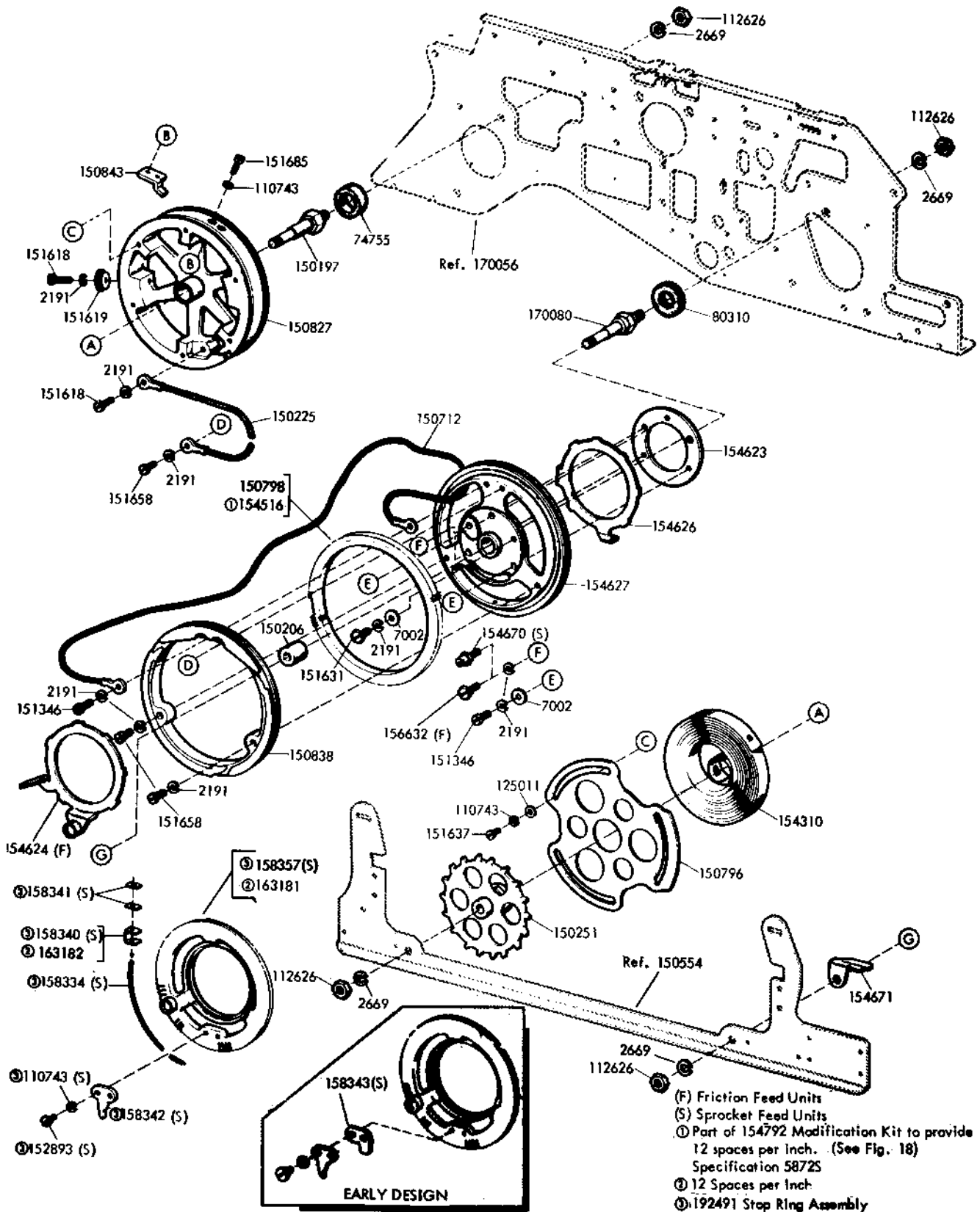
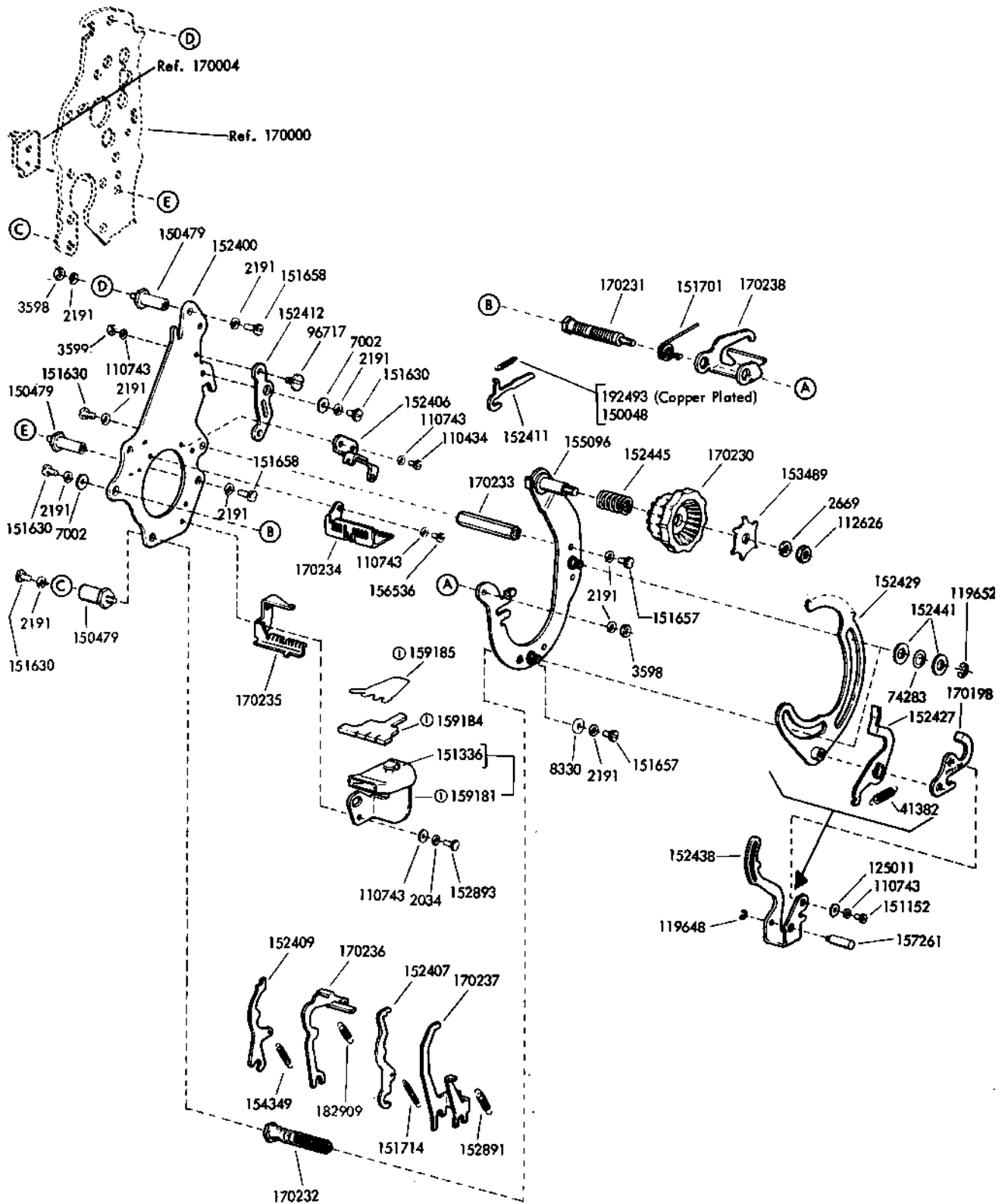
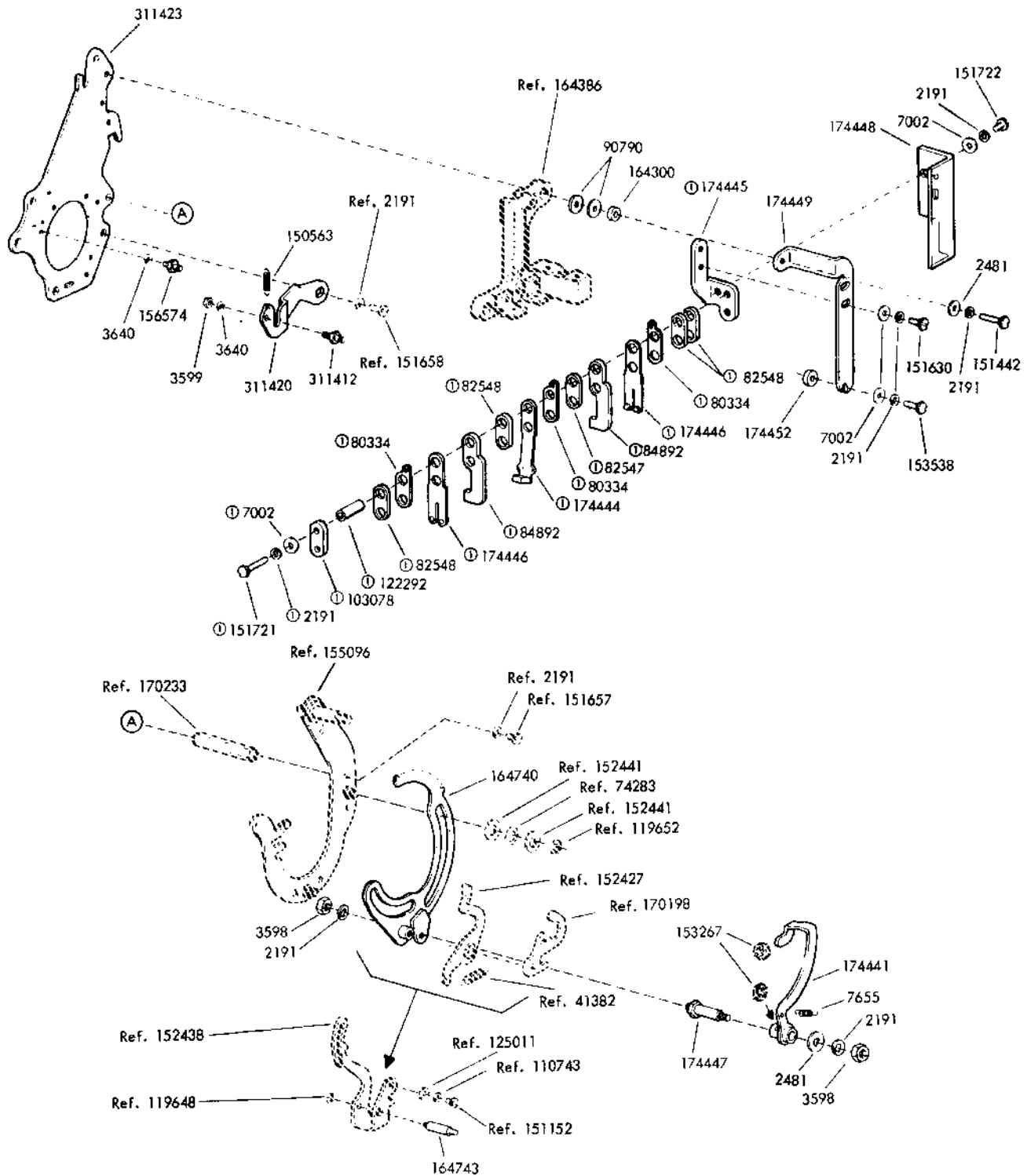

FIGURE 22. CARRIAGE RETURN AND SPACING DRUM MECHANISM



⊙170124 Oiler Assembly

FIGURE 23. SELECTOR MECHANISM



ⓐ 174442 Contact Assembly

FIGURE 24. SELECTOR MAGNET TIMING CONTACT MECHANISM

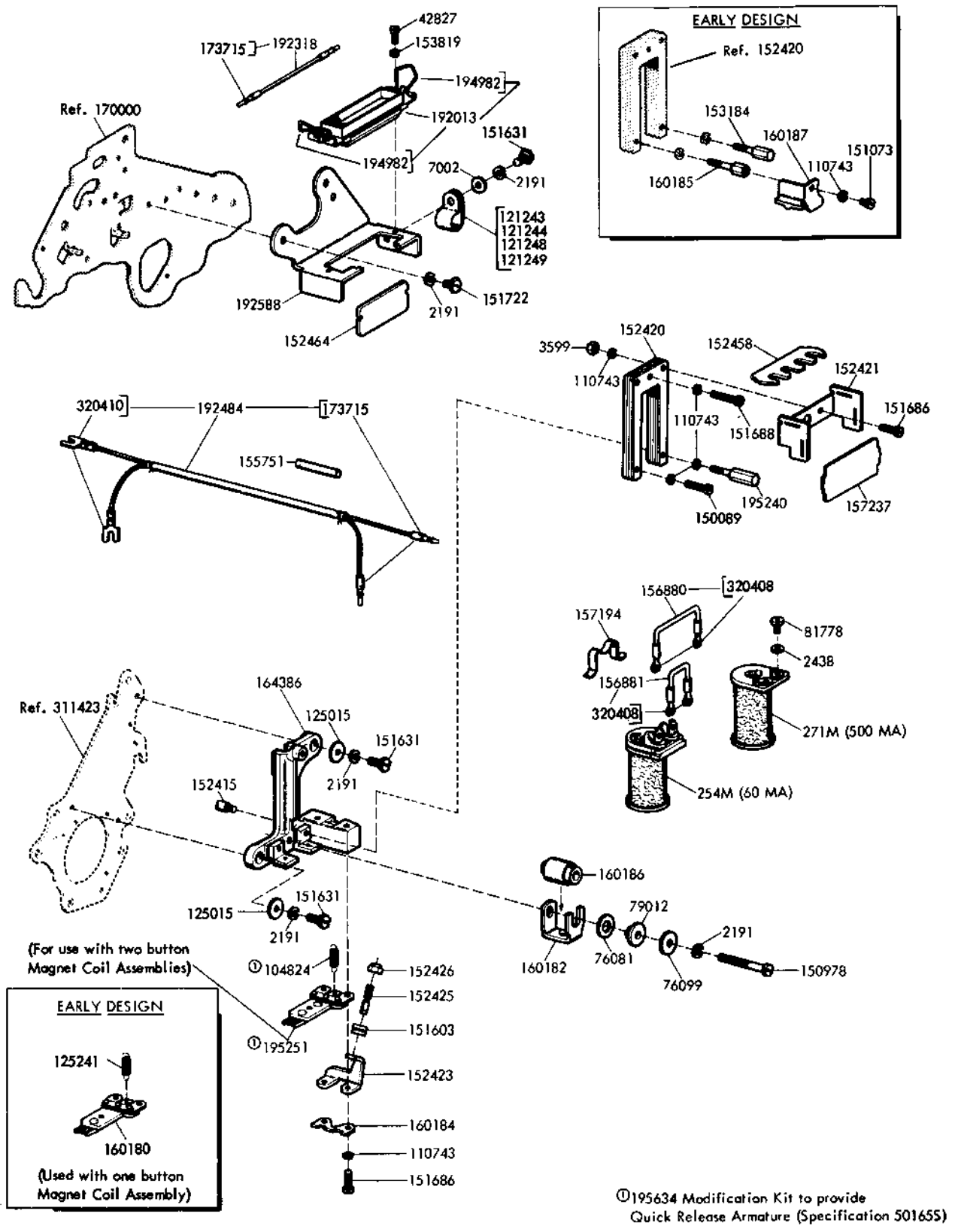

FIGURE 25. SELECTOR MAGNET MECHANISM

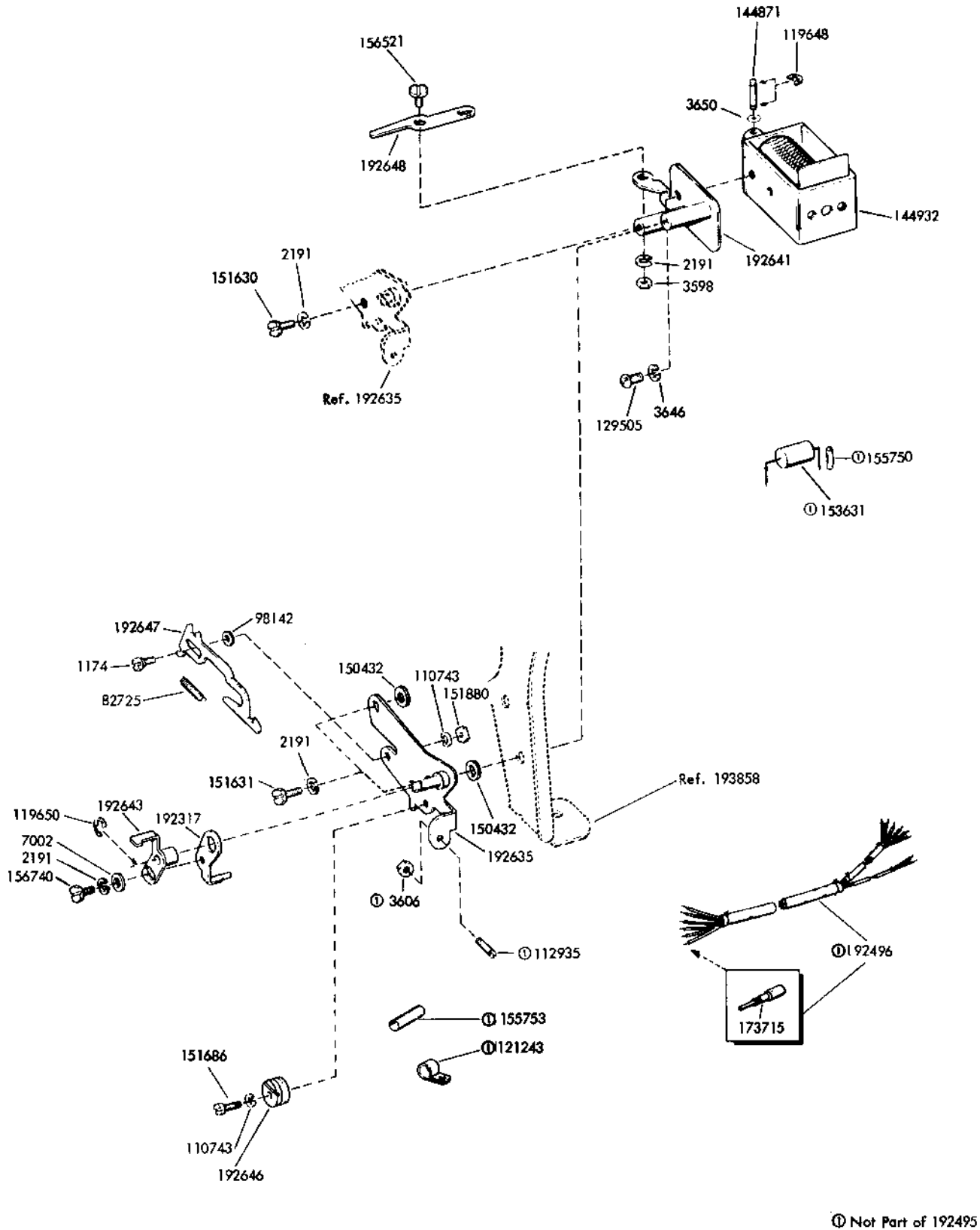

FIGURE 26. 192495 FORM-OUT SOLENOID ASSEMBLY

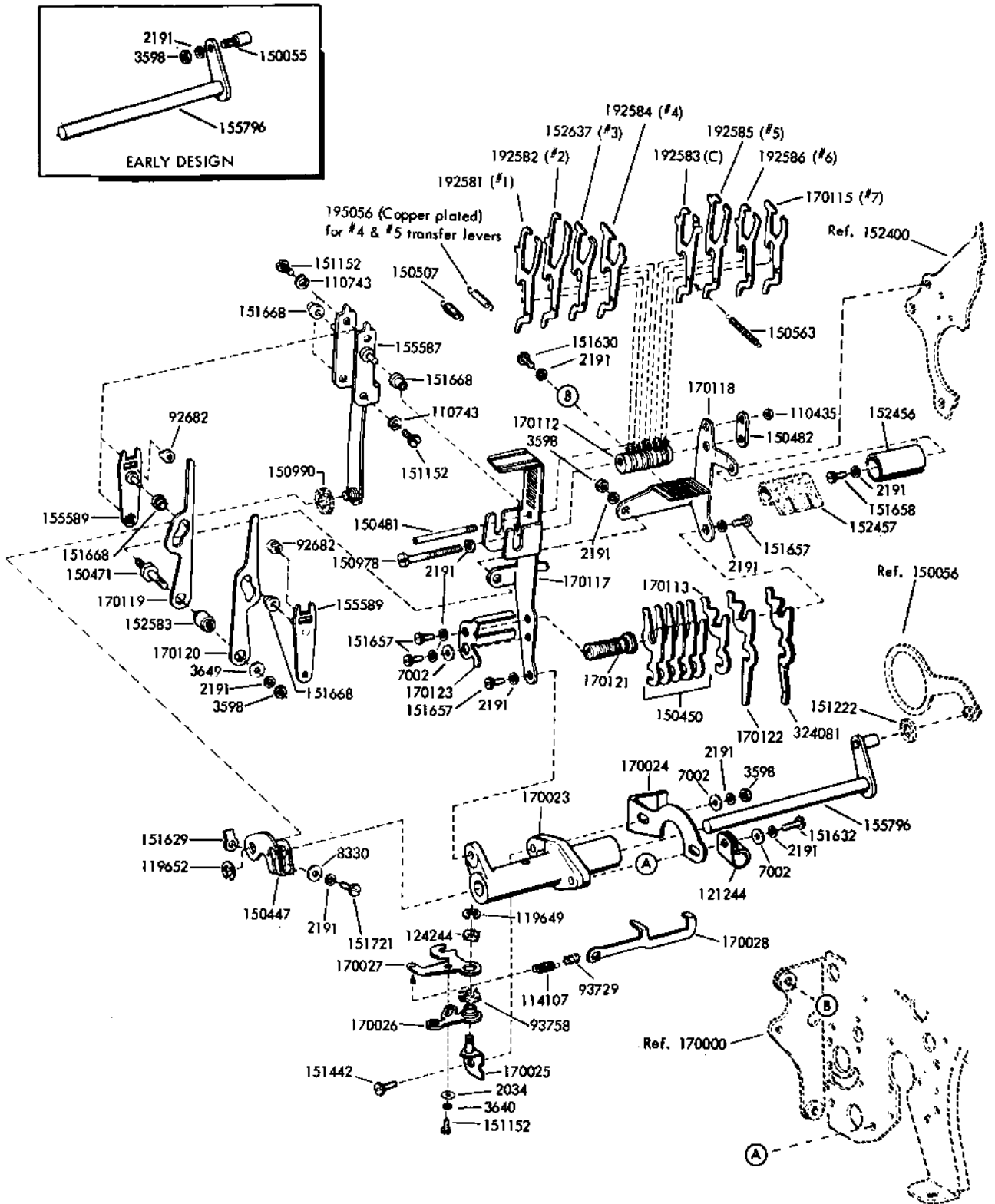

FIGURE 27. CODEBAR POSITIONING MECHANISM

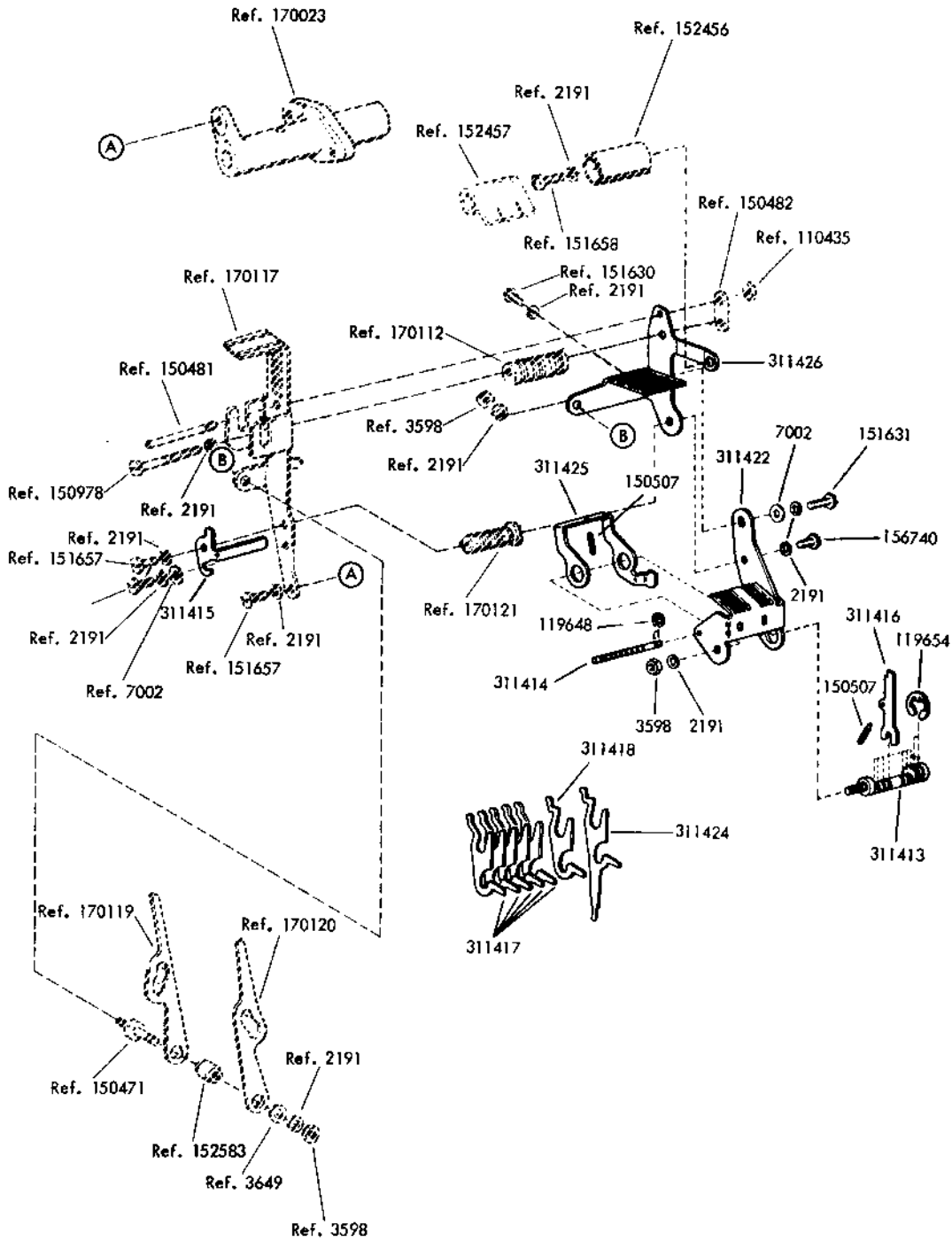

FIGURE 28. INTERMEDIATE STORAGE FEATURE FOR CODEBAR POSITIONING MECHANISM



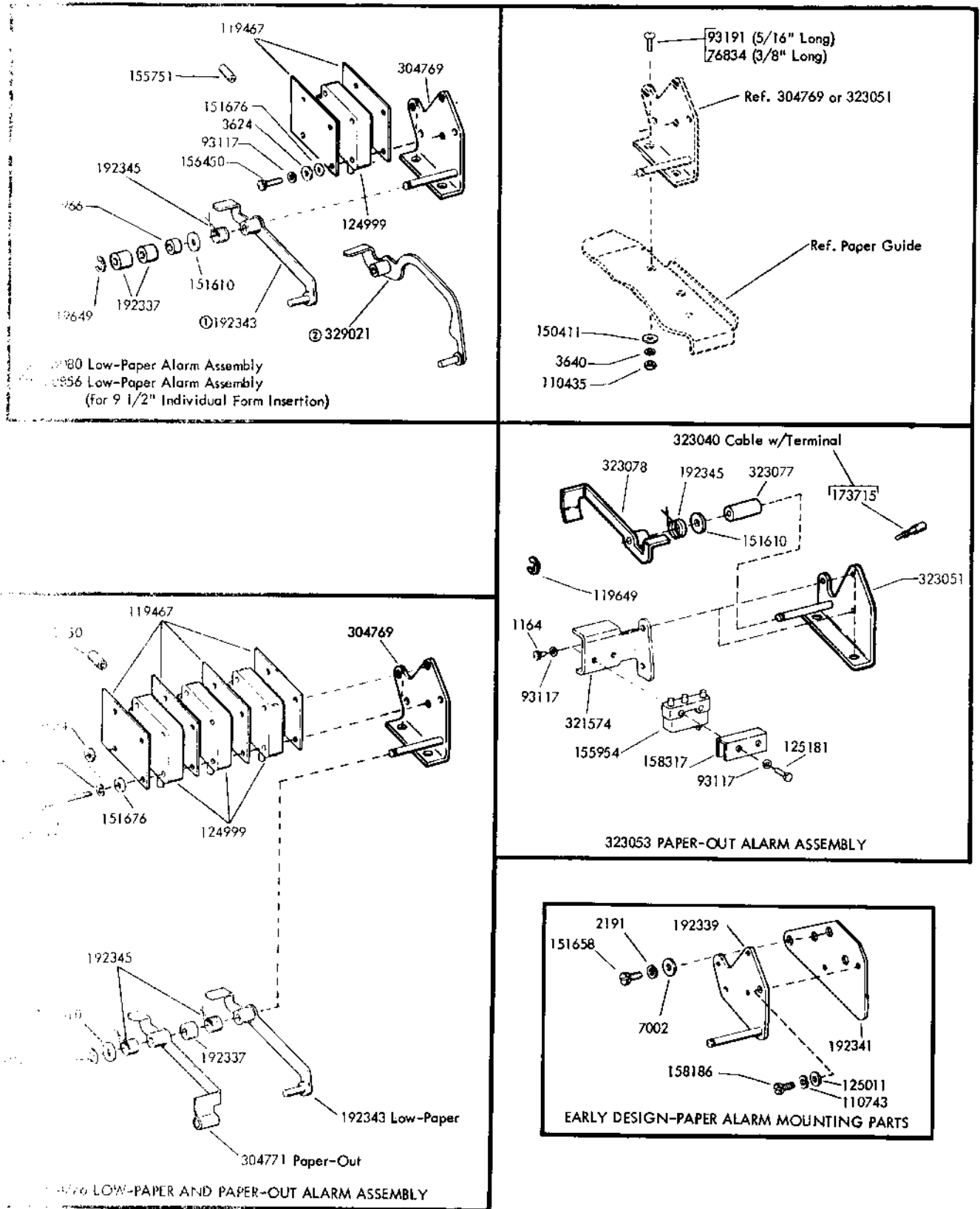

FIGURE 29. LOW-PAPER AND PAPER-OUT ALARMS

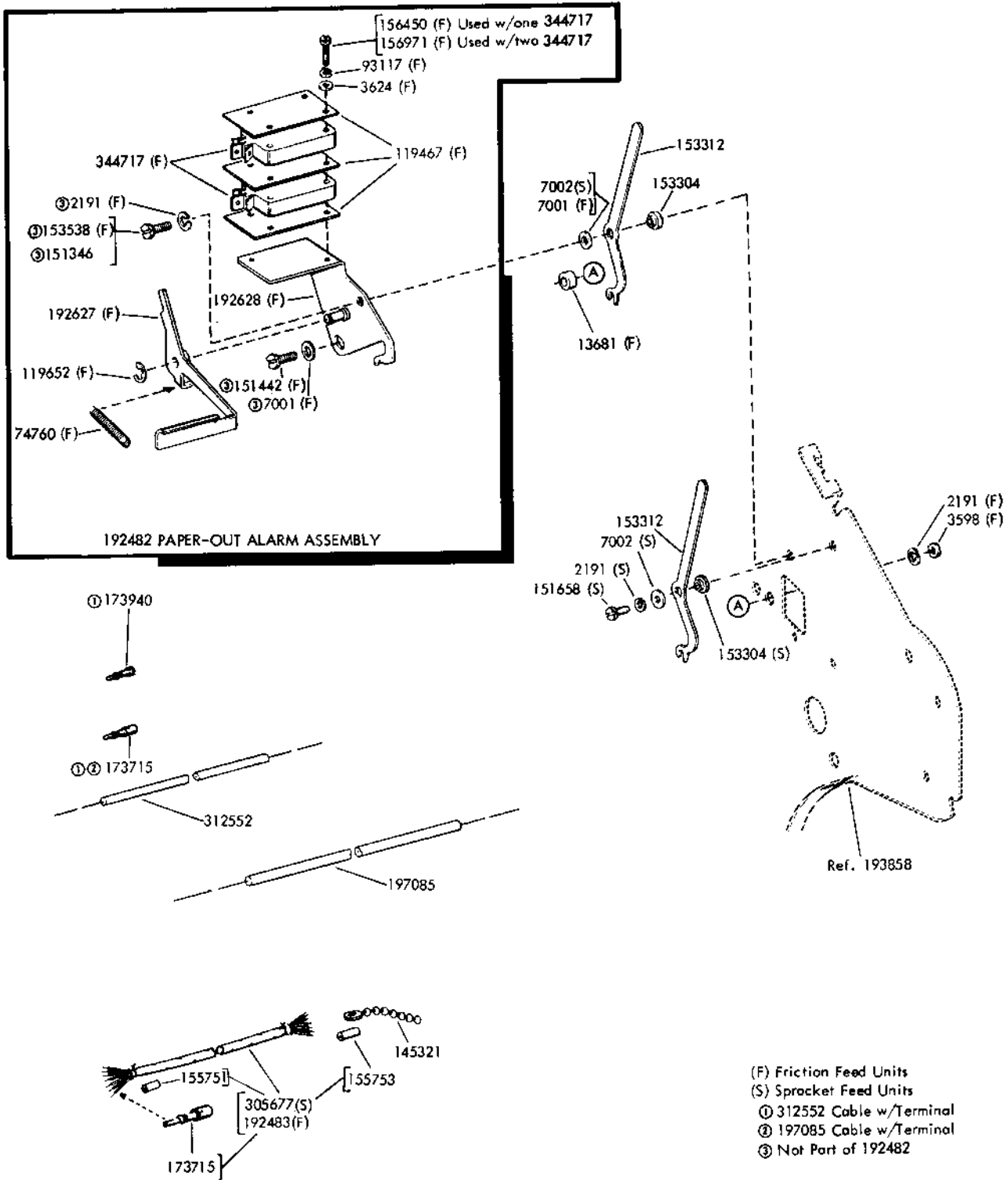

FIGURE 30. PAPER ALARMS AND FORM-OUT MECHANISMS

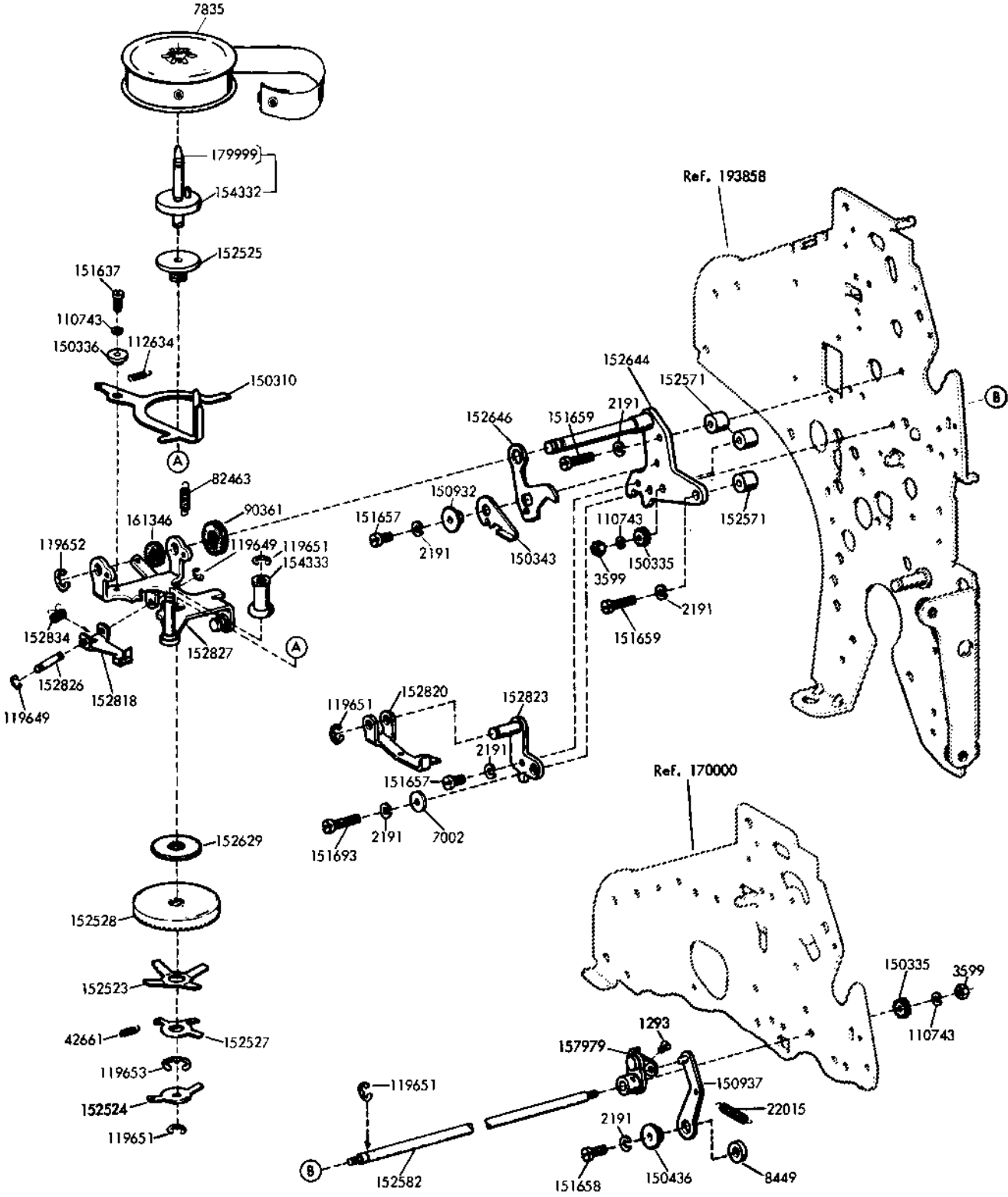

FIGURE 31. LEFT RIBBON FEED MECHANISM

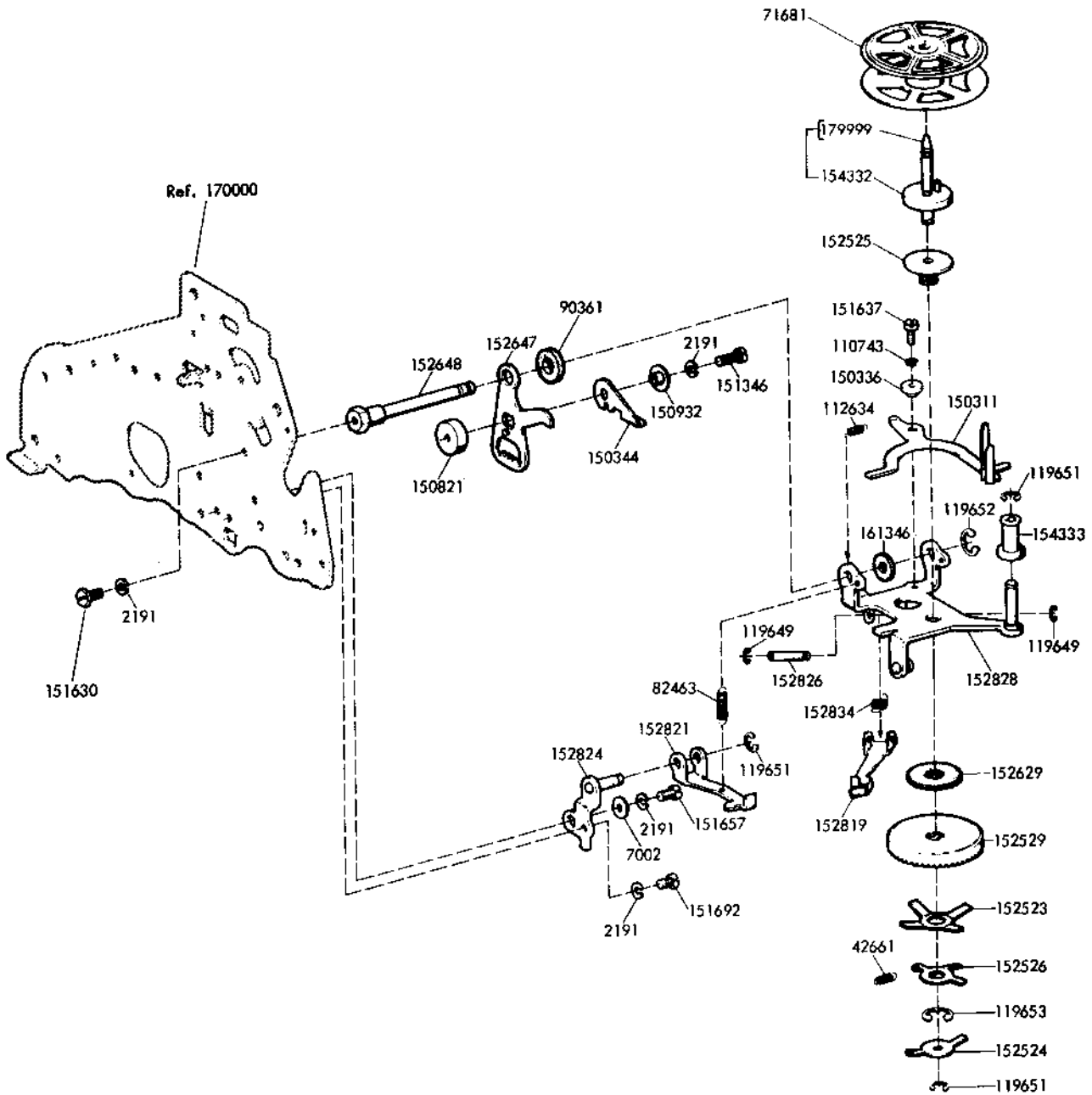

FIGURE 32. RIGHT RIBBON FEED MECHANISM

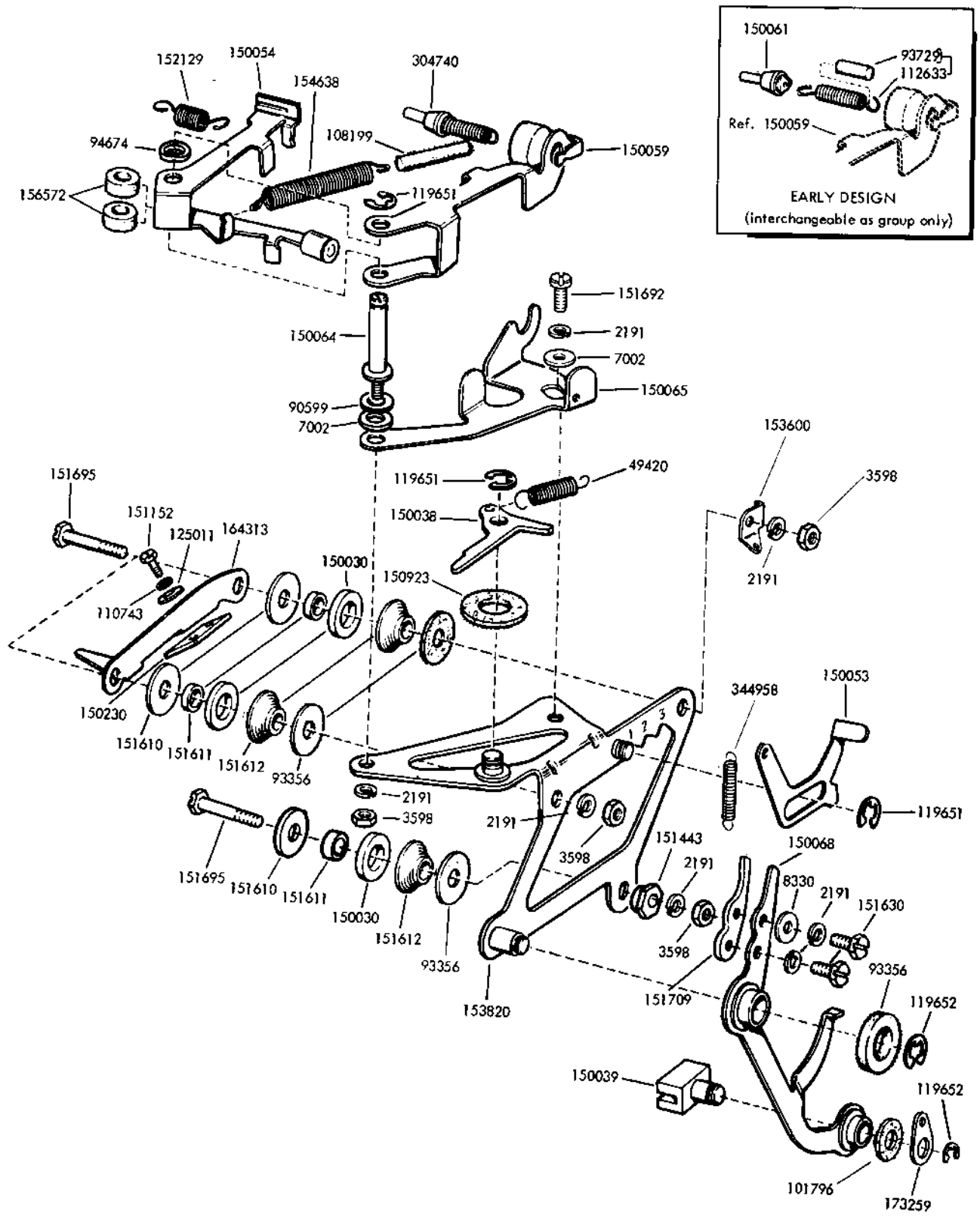

FIGURE 33. 173260 PRINTING CARRIAGE MECHANISM

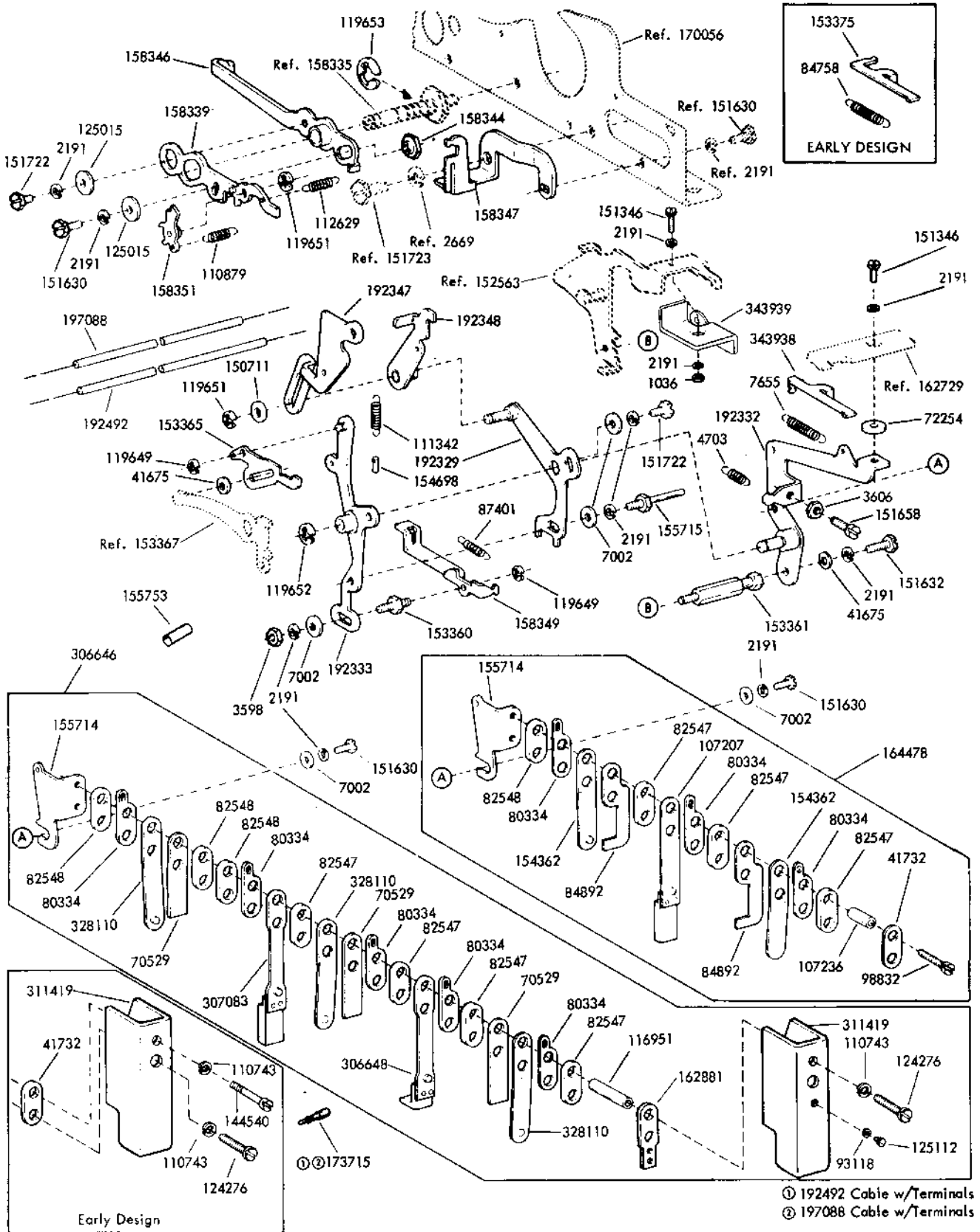

FIGURE 34. HORIZONTAL TABULATING MECHANISM

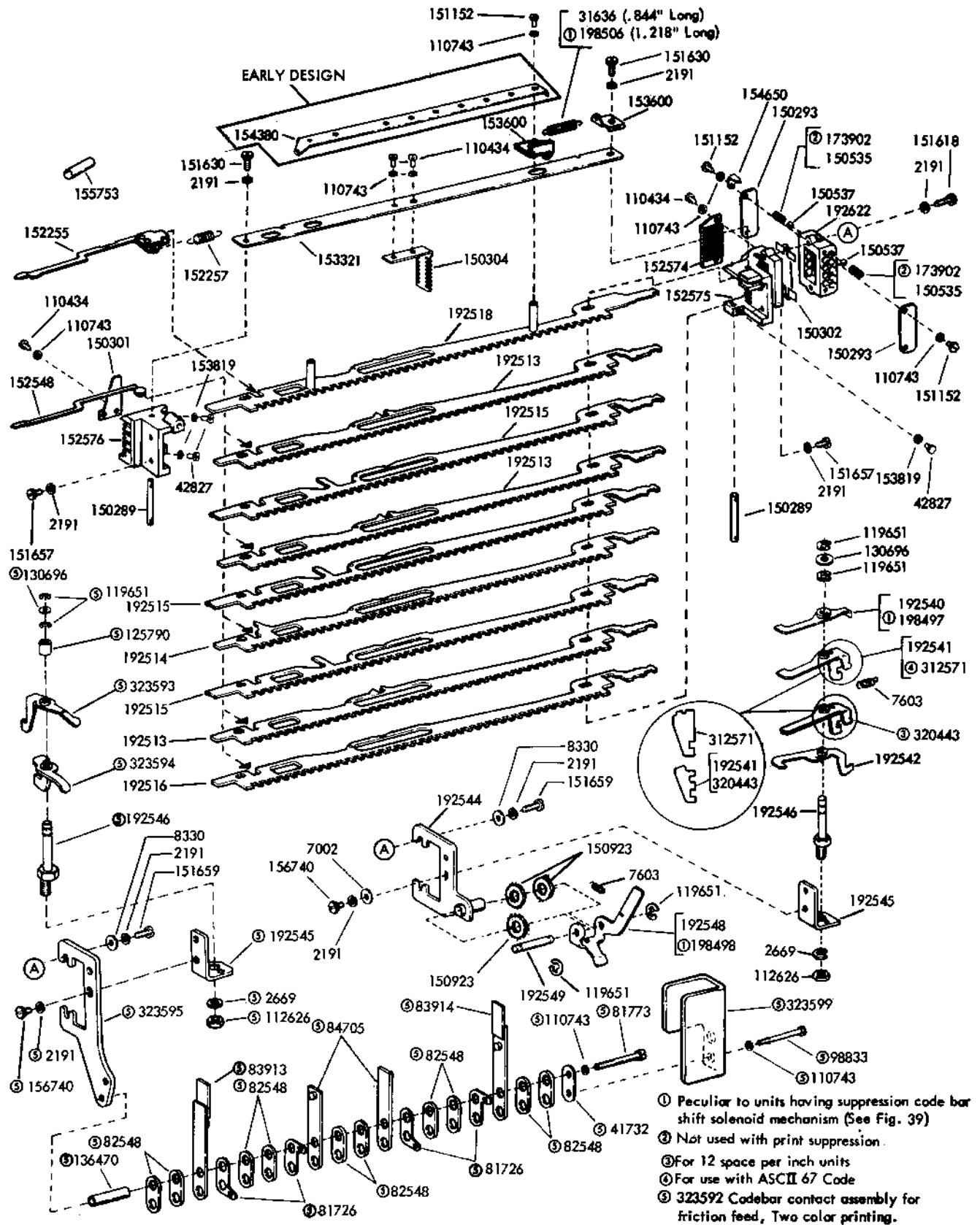

FIGURE 35. CODEBAR MECHANISM

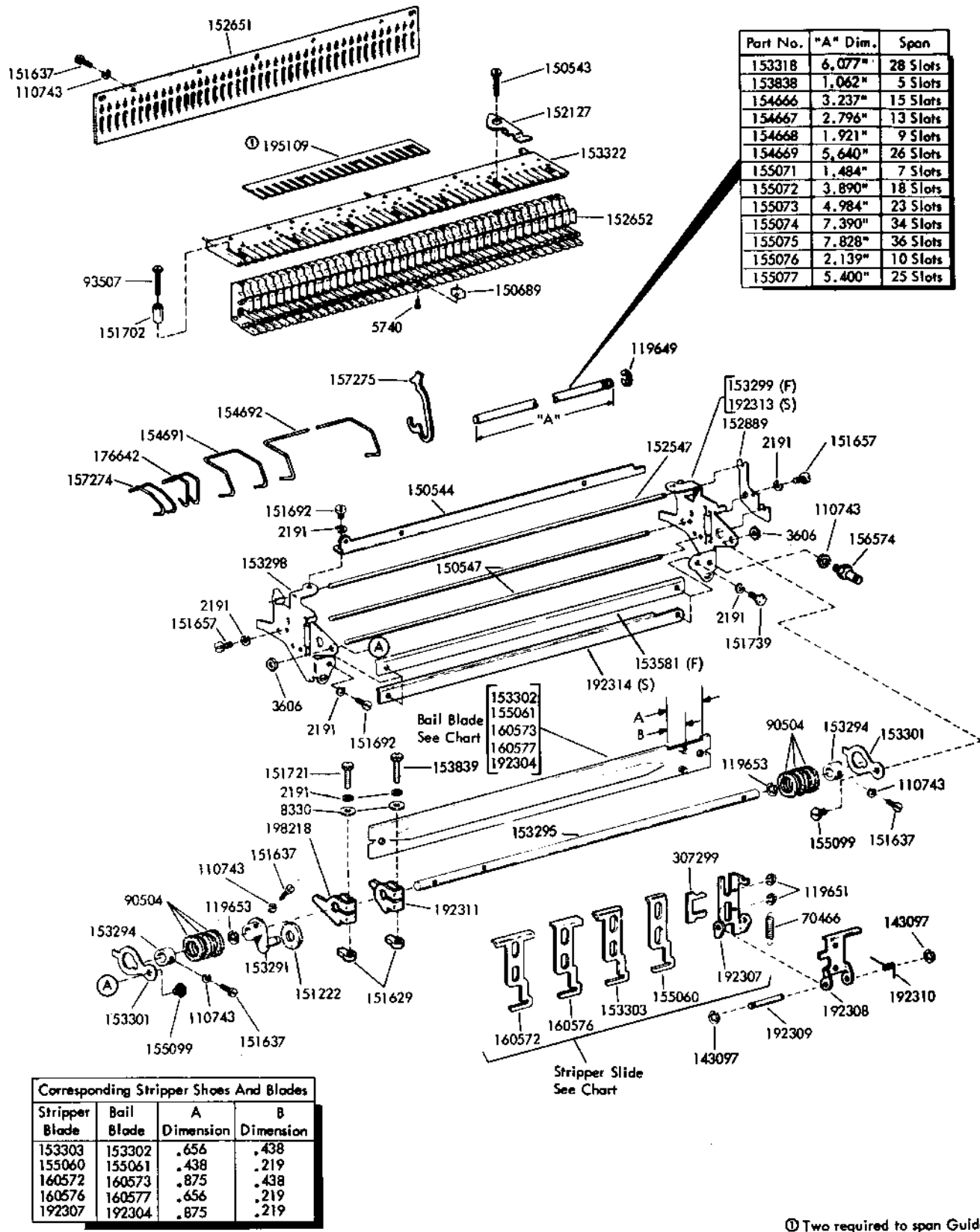

FIGURE 36. BASIC STUNT BOX COMPONENTS





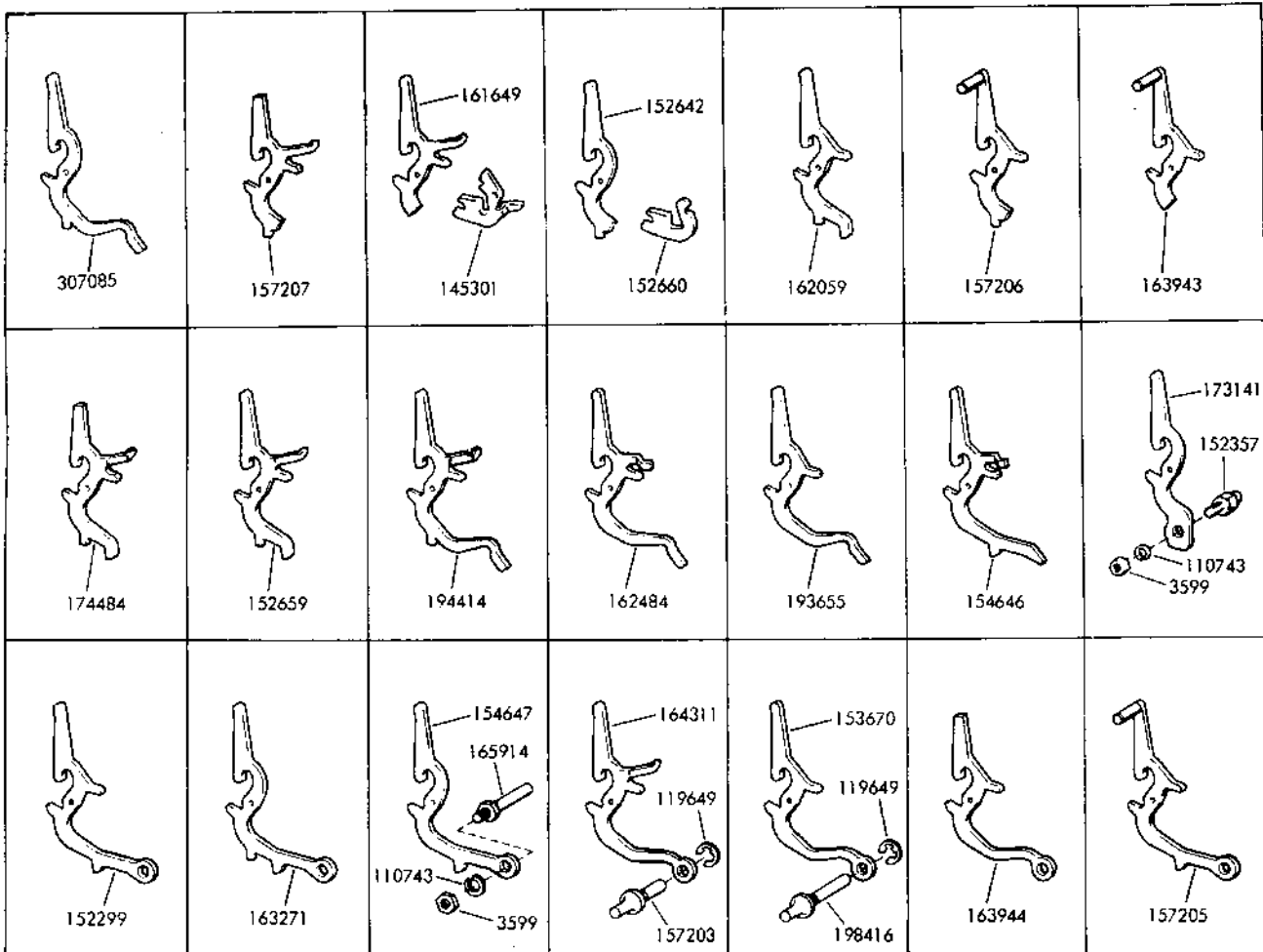
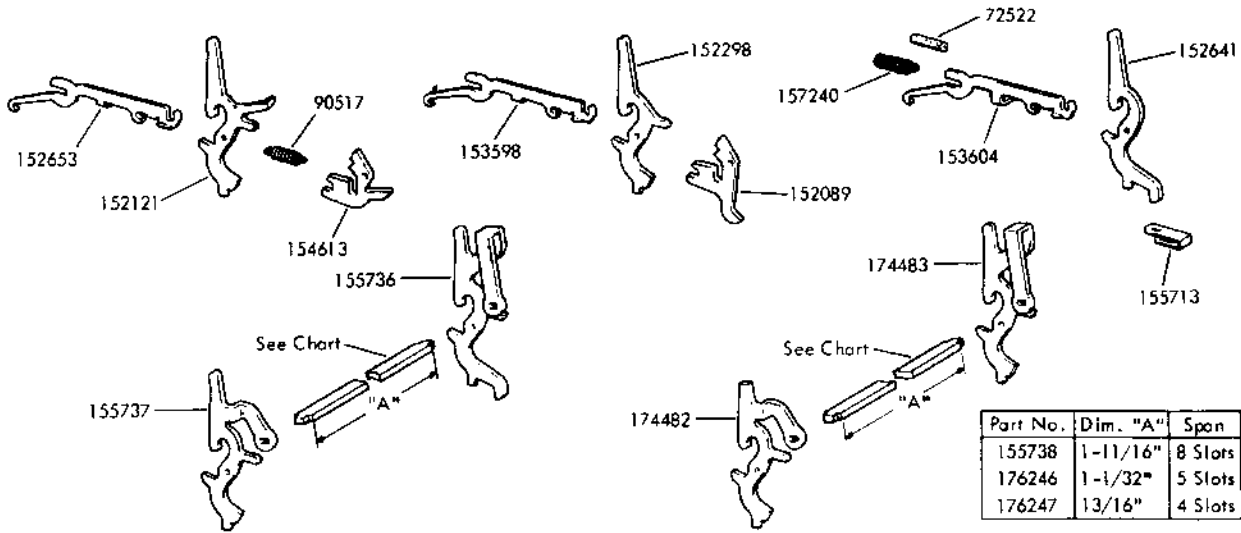

FIGURE 38. FUNCTION LEVERS AND PAWLS

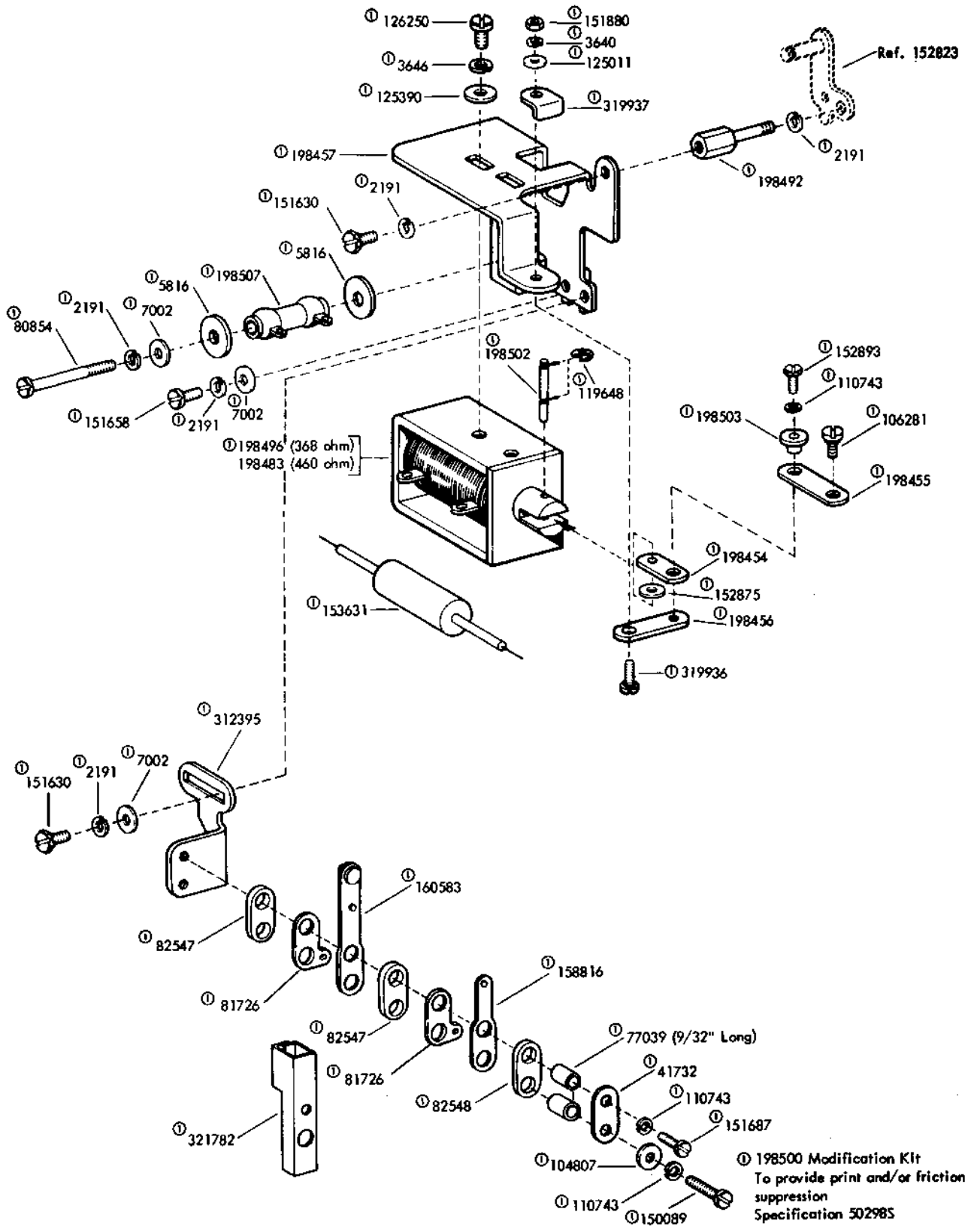
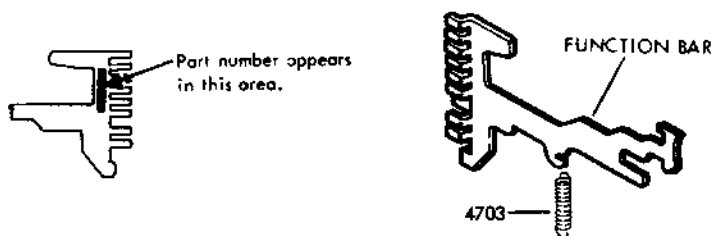

FIGURE 39. SUPPRESSION SOLENOID MECHANISM



Function Bar Number	Description of Function Character	Function Bar Function Character ASCII 63 Code	Function Bar Mnemonic Character ASCII 67 Code	Function Bar Bell System Usage Function Character ASCII 67 Code	Function Bar Private Line Usage Function Characters
152704	Universal -No Tines				
153440	Uncoded -Two Full Rows of Tines				
192459	Carriage Return	CR	CR	RETURN	CR (Return)
192460 ①	Receiver Off	DC 4 (Stop)	DC 4	TAPE	DC 4 (TAPE)
192461 ①	End of Message	EOM	ETX	ETX	EOM or ETX
192462	Receiver On	DC 2 (TAPE)	DC 2	TAPE	DC 2 TAPE
192463	Bell	BELL	BEL	BELL	BELL
192464	Horizontal Tabulation	H-TAB	HT	TAB	H-TAB or HT
192465	Who Are You	Enquiry	WRU	WRU	WRU or ENQ
192466	End of Transmission	EOT	EOT	EOT	EOT
192467	Transmitter Off	DC 3 (X-OFF)	DC 3	X-OFF	DC 3 (X-OFF)
192468	Are You	Acknowledge	RU	ACK	ACK or RU
192469	Transmitter On	DC 1 (X-ON)	DC1	X-ON	DC 1 (X-ON)
192470	Acknowledge	ACK			ACK
192471 ①	Line Feed	LF	LF	LINE FEED	LF (Line Feed)
192472	Vertical Tabulation	V-TAB	VT		V-TAB or VT
192473	Form Feed	FF	FF	FF	FF
192474	Escape (For Data Processing)	ESC			ESC
192475	Horizontal & Vertical Tabulation	H&V TAB	HT&VT	HT&VT	H&VTAB or HT&VT
192476 ①	Blank	BLANK / Idle	NUL (Blank)	NULL (Blank)	NULL (Blank)
192477	Carriage Return-Form Feed	CR-FF	CR-FF	CR-FF	CR-FF
192478	For Data Processing Function	TREMA	TREMA	TREMA	TREMA
192479	For Data Processing Function	CIRCUMFLEX	CIRCUMFLEX	CIRCUMFLEX	CIRCUMFLEX
192480	For Data Processing Function	GRAVE ACCENT	GRAVE ACCENT	GRAVE ACCENT	GRAVE ACCENT
198463	Device Control	Data Link Escape	DCo	DLE	DCo or DLE
198464	End of Address	Start of Text	EOA	STX	EOA or STX
198465	Any Symbol	GRAPHIC	GRAPHIC	GRAPHIC	GRAPHIC
198467 ②	Blank	NULL	NULL	NULL	NULL (Blank)
198468	Space	SPACE	SPACE	SPACE	SPACE
198469	Start of Message	Start of Heading	SOM	SOH	SOM or SOH
198470	Escape (For Data Processing)		ESC	ESC	ESC
198471 ②	End of Text		ETX	ETX	ETX
198472 ②	Line Feed or Vertical Tabulation		LF or VT	LF or VT	LF or VT
198473 ②	Receiver Off	Device Control	DC4	DC4	DC 4
199224	Line Feed				LF
199225	Carriage Return				CR
301761	Alternate-Mode				ALT-MODE
301762	Answer Back				V
301763	Time Stamp				TIME
301764	Upper Case - Time Stamp				UCTIME
306704	For Data Processing Function				SPECIAL
306705	For Data Processing Function				SPECIAL
306706	For Data Processing Function				SPECIAL
315532	Shift Out	SO	SO	SO	SO
315533	Shift In	SI	SI	SI	SI
317218	For Data Processing Function				SPECIAL

① Senses suppression bar in space  
 ② Senses in either mark or space condition  
 ( ) Indicates possible implementation

FIGURE 40. FUNCTION BARS



GOTHIC "12-TO-INCH"				LONG GOTHIC STYLE				LARGE GOTHIC PALLETS				GOTHIC STYLE				COMBINATION STYLE			
PALLET NUMBER		19974 "TH"	32465 "DG"	PALLET NUMBER		19986 "TJ"		PALLET		310309"TR"	321705"DB"	PALLET NUMBER		307180 "TN"	PALLET NUMBER		19799 "TE"	305090 "TP"	
A	155432	X	X	A	155618	X		A	157729	157729		A	159752	X	X	A	159752	X	X
B	155433	X	X	B	155619	X		B	157730	321780		B	159753	X	X	B	159753	X	X
C	155434	X	X	C	155620	X		C	157731	321681		C	159754	X	X	C	159754	X	X
D	155435	X	X	D	155621	X		D	157732	321695		D	159755	X	X	D	159755	X	X
E	155436	X	X	E	155622	X		E	157733	321698		E	159756	X	X	E	159756	X	X
F	155437	X	X	F	155623	X		F	157734	321682		F	159757	X	X	F	159757	X	X
G	155438	X	X	G	155624	X		G	157735	157735		G	159758	X	X	G	159758	X	X
H	155439	X	X	H	155625	X		H	157736	321683		H	159759	X	X	H	159759	X	X
I	155440	X	X	I	155626	X		I	157737	157737		I	159760	X	X	I	159760	X	X
J	155441	X	X	J	155627	X		J	157738	321684		J	159761	X	X	J	159761	X	X
K	155442	X	X	K	155628	X		K	157739	157739		K	159762	X	X	K	159762	X	X
L	155443	X	X	L	155629	X		L	157740	321697		L	159763	X	X	L	159763	X	X
M	155444	X	X	M	155630	X		M	157741	157741		M	159764	X	X	M	159764	X	X
N	155445	X	X	N	155631	X		N	157742	157742		N	159765	X	X	N	159765	X	X
O	155446	X	X	O	155632	X		O	157743	321696		O	159766	X	X	O	159766	X	X
P	155447	X	X	P	155633	X		P	157744	321685		P	159767	X	X	P	159767	X	X
Q	155448	X	X	Q	155634	X		Q	157745	321700		Q	159768	X	X	Q	159768	X	X
R	155449	X	X	R	155635	X		R	157746	321686		R	159769	X	X	R	159769	X	X
S	155450	X	X	S	155636	X		S	157747	157747		S	159770	X	X	S	159770	X	X
T	155451	X	X	T	155637	X		T	157748	157748		T	159771	X	X	T	159771	X	X
U	155452	X	X	U	155638	X		U	157749	321699		U	159772	X	X	U	159772	X	X
V	155453	X	X	V	155639	X		V	157750	157750		V	159773	X	X	V	159773	X	X
W	155454	X	X	W	155640	X		W	157751	157751		W	159774	X	X	W	159774	X	X
X	155455	X	X	X	155641	X		X	157752	157752		X	159775	X	X	X	159775	X	X
Y	155456	X	X	Y	155642	X		Y	157753	321687		Y	159776	X	X	Y	159776	X	X
Z	155457	X	X	Z	155643	X		Z	157754	157754		Z	159777	X	X	Z	159777	X	X
1	155458	X	X	1	155644	X		1	157755	157755		1	159778	X	X	1	159778	X	X
2	155459	X	X	2	155645	X		2	157756	157756		2	159779	X	X	2	159779	X	X
3	155460	X	X	3	155646	X		3	157757	157757		3	159780	X	X	3	159780	X	X
4	155461	X	X	4	155647	X		4	157758	157758		4	159781	X	X	4	159781	X	X
5	155462	X	X	5	155648	X		5	157759	157759		5	159782	X	X	5	159782	X	X
6	155463	X	X	6	155649	X		6	157760	157760		6	159783	X	X	6	159783	X	X
7	155464	X	X	7	155650	X		7	157761	157761		7	159784	X	X	7	159784	X	X
8	155465	X	X	8	155651	X		8	157762	157762		8	159785	X	X	8	159785	X	X
9	155466	X	X	9	155652	X		9	157763	157763		9	159786	X	X	9	159786	X	X
.	157636	X	X	.	155653	X		.	157764	157764		.	157636	X	X	.	157636	X	X
.	157637	X	X	.	155654	X		.	157765	157765		.	157637	X	X	.	157637	X	X
.	157638	X	X	.	155655	X		.	157766	157766		.	157638	X	X	.	157638	X	X
.	194886	X	X	.	155656	X		.	157767	157767		.	157639	X	X	.	157639	X	X
.	157642	X	X	.	155657	X		.	157768	157768		.	157640	X	X	.	157640	X	X
.	157644	X	X	.	155658	X		.	157769	157769		.	157641	X	X	.	157641	X	X
.	157644	X	X	.	155659	X		.	157770	157770		.	157642	X	X	.	157642	X	X
.	157645	X	X	.	155660	X		.	157771	157771		.	157643	X	X	.	157643	X	X
.	157646	X	X	.	155661	X		.	157772	157772		.	157644	X	X	.	157644	X	X
.	157648	X	X	.	155662	X		.	157773	157773		.	157645	X	X	.	157645	X	X
.	155469	X	X	.	155663	X		.	157774	157774		.	157646	X	X	.	157646	X	X
.	199990	X	X	.	155664	X		.	157775	157775		.	157647	X	X	.	157647	X	X
.	199989	X	X	.	155665	X		.	157776	157776		.	157648	X	X	.	157648	X	X
.	161366	X	X	.	155666	X		.	157777	157777		.	157649	X	X	.	157649	X	X
.	161369	X	X	.	155667	X		.	157778	157778		.	157650	X	X	.	157650	X	X
.	155479	X	X	.	155668	X		.	157779	157779		.	157651	X	X	.	157651	X	X
.	194335	X	X	.	155669	X		.	157780	157780		.	157652	X	X	.	157652	X	X
.	194209	X	X	.	155670	X		.	157781	157781		.	157653	X	X	.	157653	X	X
.	194208	X	X	.	155671	X		.	157782	157782		.	157654	X	X	.	157654	X	X
.	163197	X	X	.	155672	X		.	157783	157783		.	157655	X	X	.	157655	X	X
.	163198	X	X	.	155673	X		.	157784	157784		.	157656	X	X	.	157656	X	X
.	199987	X	X	.	155674	X		.	157785	157785		.	157657	X	X	.	157657	X	X
.	194336	X	X	.	155675	X		.	157786	157786		.	157658	X	X	.	157658	X	X
.	155871	X	X	.	155676	X		.	157787	157787		.	157659	X	X	.	157659	X	X
.	157647	X	X	.	155677	X		.	157788	157788		.	157660	X	X	.	157660	X	X
.	157641	X	X	.	155678	X		.	157789	157789		.	157661	X	X	.	157661	X	X
.	157640	X	X	.	155679	X		.	157790	157790		.	157662	X	X	.	157662	X	X
.	155483	X	X	.	155680	X		.	157791	157791		.	157663	X	X	.	157663	X	X
.	157639	X	X	.	155681	X		.	157792	157792		.	157664	X	X	.	157664	X	X
.	155467	X	X	.	155682	X		.	157793	157793		.	157665	X	X	.	157665	X	X
.	155470	X	X	.	155683	X		.	157794	157794		.	157666	X	X	.	157666	X	X
.	155473	X	X	.	155684	X		.	157795	157795		.	157667	X	X	.	157667	X	X
.	155480	X	X	.	155685	X		.	157796	157796		.	157668	X	X	.	157668	X	X
.	157658	X	X	.	155686	X		.	157797	157797		.	157669	X	X	.	157669	X	X
.	157678	X	X	.	155687	X		.	157798	157798		.	157670	X	X	.	157670	X	X
.	195200	X	X	.	155688	X		.	157799	157799		.	157671	X	X	.	157671	X	X
.	305584	X	X	.	155689	X		.	157800	157800		.	157672	X	X	.	157672	X	X
.	305589	X	X	.	155690	X		.	157801	157801		.	157673	X	X	.	157673	X	X
.	305590	X	X	.	155691	X		.	157802	157802		.	157674	X	X	.	157674	X	X
.				.	155692	X		.	157803	157803		.	157675	X	X	.	157675	X	X
.				.	155693	X		.	157804	157804		.	157676	X	X	.	157676	X	X
.				.	155694	X		.	157805	157805		.	157677	X	X	.	157677	X	X
.				.	155695	X		.	157806	157806		.	157678	X	X	.	157678	X	X
.				.	155696	X		.	157807	157807		.	157679	X	X	.	157679	X	X
.				.	155697	X		.	157808	157808		.	157680	X	X	.	157680	X	X
.				.	155698	X		.	157809	157809		.	157681	X	X	.	157681	X	X
.				.	155699	X		.	157810	157810		.	157682	X	X	.	157682	X	X
.				.	155700	X		.	157811	157811		.	157683	X	X	.	157683	X	X
.				.	155701	X		.	157812	157812		.	157684	X	X	.	157684	X	X
.				.	155702	X		.	157813	157813		.	157685	X	X	.	157685	X	X
.				.	155703	X		.	157814	157814		.	157686	X	X	.	157686	X	X
.				.	155704	X		.	157815	157815		.	157687	X	X	.	157687	X	X
.				.	155705	X		.	157816	157816		.	157688	X	X	.	157688	X	X
.				.	155706	X		.	157817	157817		.	157689	X	X	.	157689	X	X



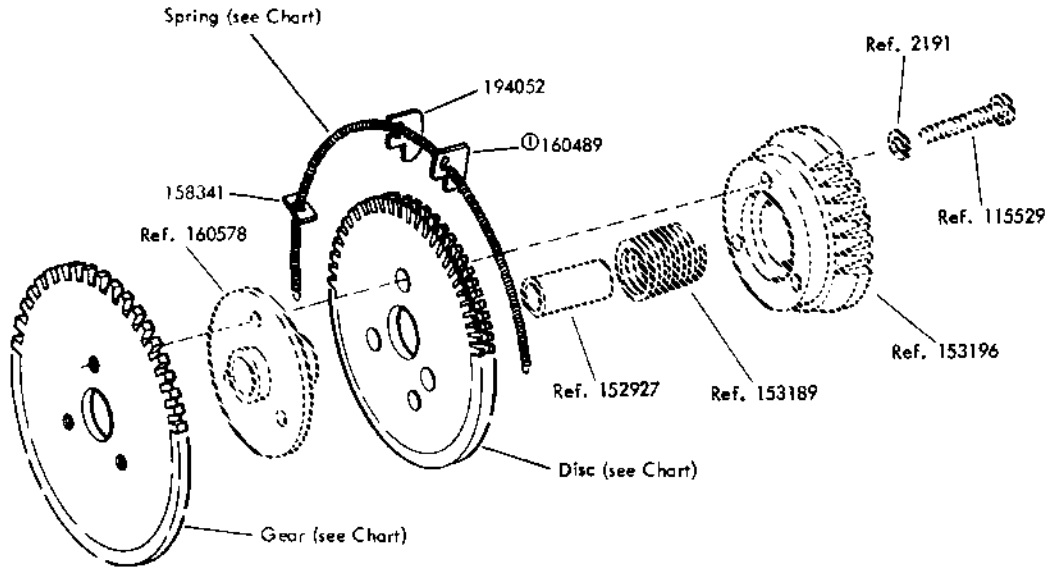

Form Length in inches	Mod. Kit No.	Gear No.	Disc No.	Spring No.	No. of Stops
8, 4, 2	154760	153198	160505	160527	47
8-1/2	154761	153199	160506	160528	10
9, 4-1/2	154762	153200	160507	160529	10
9-1/2	154763	153201	160508	160530	11
10, 5	154764	153202	160509	160531	12
11, 5-1/2	154765	153203	160510	160532	14
12, 6, 3	154766	153204	160511	160533	15
13, 6-1/2	154767	153205	160512	160534	16
14, 7, 3-1/2	154768	153206	160513	160535	17
15, 7-1/2	154769	153207	160514	160536	18
14-2/3, 7-1/3, 3-2/3	192706	161250	192704	160536	16

①No longer available, use 194052

Specification 50004S covers all  
Vertical tabulation modification kits

FIGURE 44. VERTICAL TABULATION MODIFICATION KITS



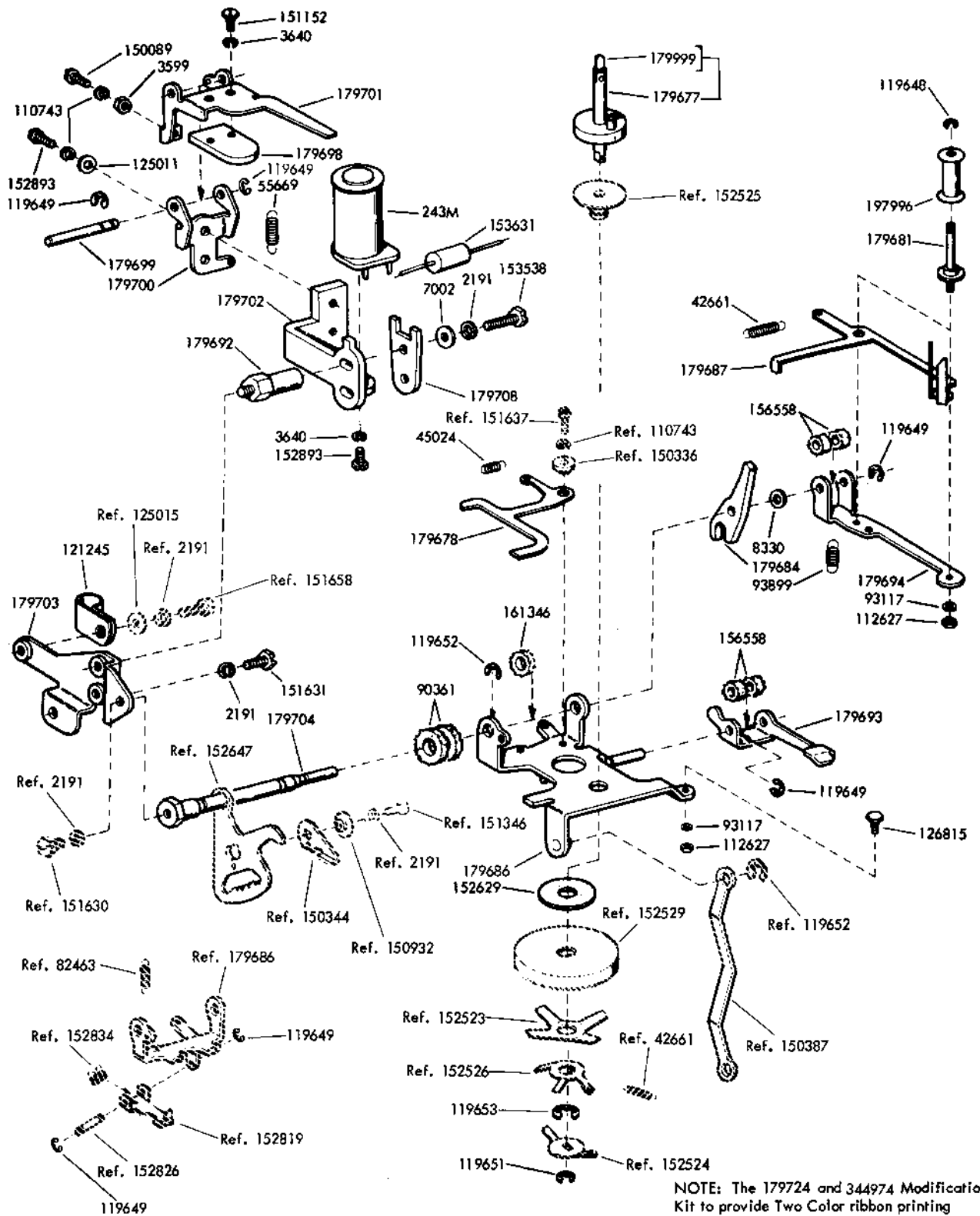
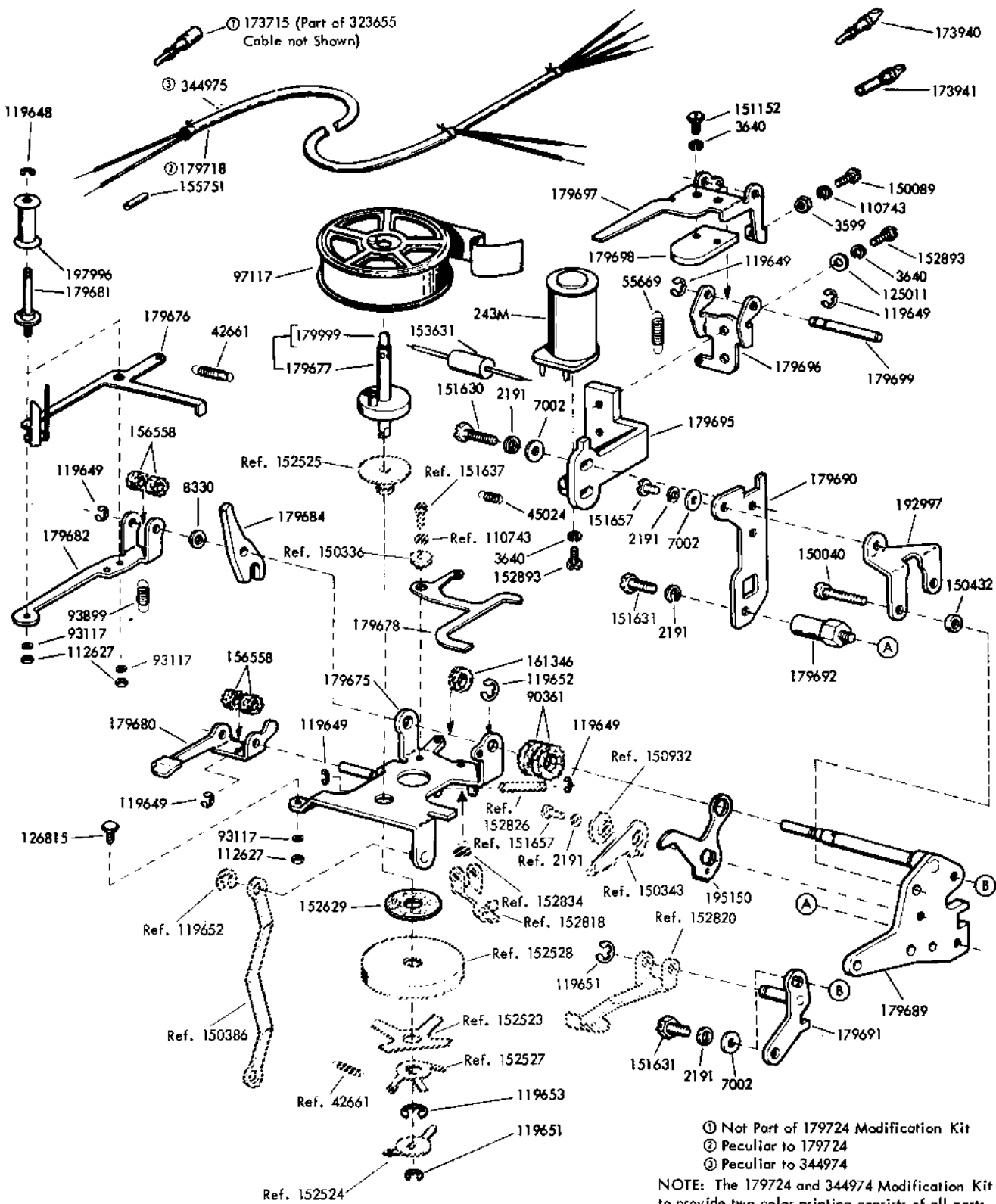

FIGURE 45. RIGHT SIDE-RIBBON FEED MECHANISM FOR TWO COLOR RIBBON PRINTING



① Not Part of 179724 Modification Kit  
 ② Peculiar to 179724  
 ③ Peculiar to 344974

NOTE: The 179724 and 344974 Modification Kit to provide two color printing consists of all parts on this figure and on Figure 45. Specification 501505

FIGURE 46. LEFT SIDE-RIBBON FEED MECHANISM FOR TWO COLOR RIBBON PRINTING

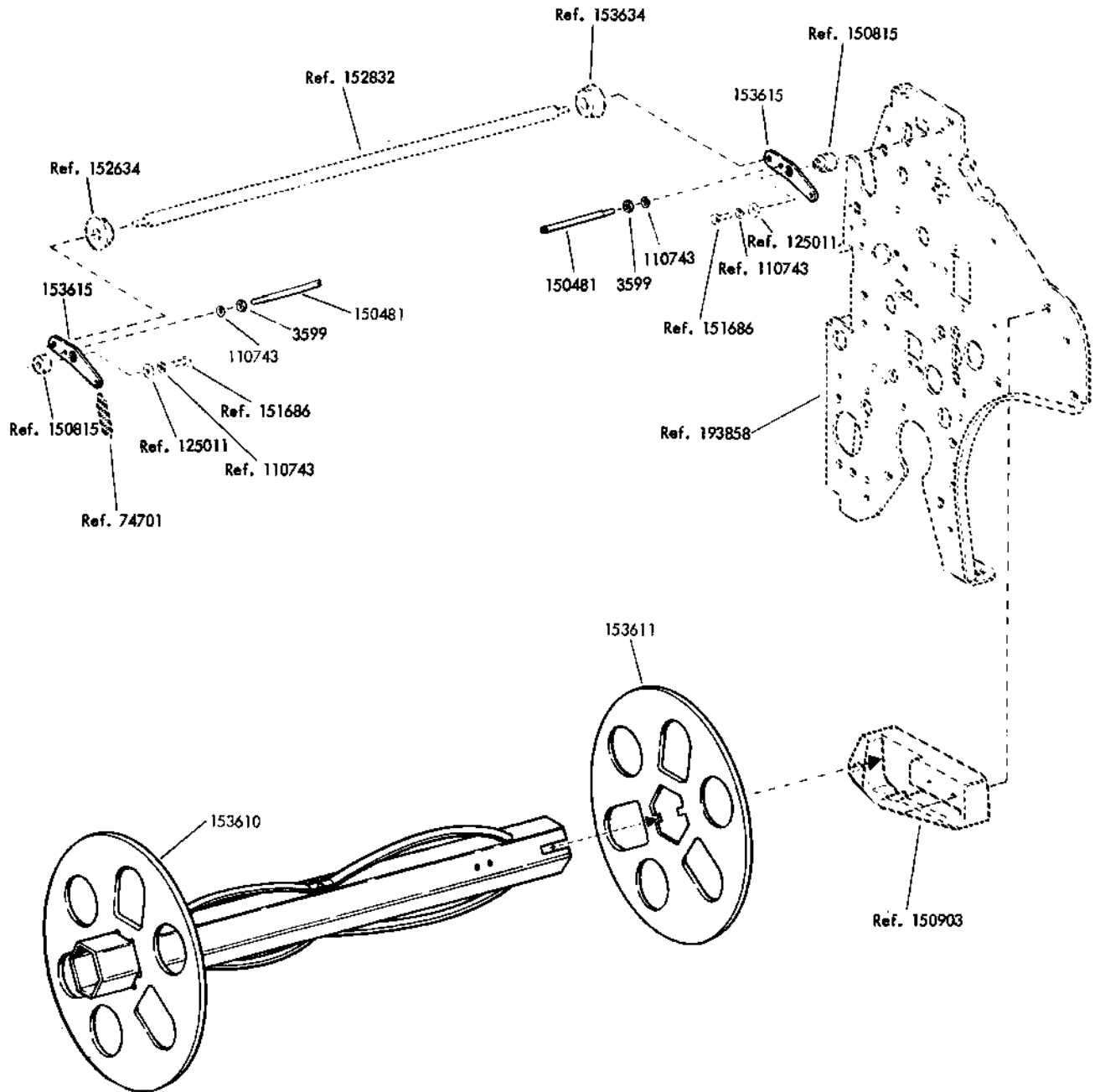

FIGURE 47. 152340 MODIFICATION KIT TO PROVIDE MULTI-COPY PAPER HANDLING

Specification 57895

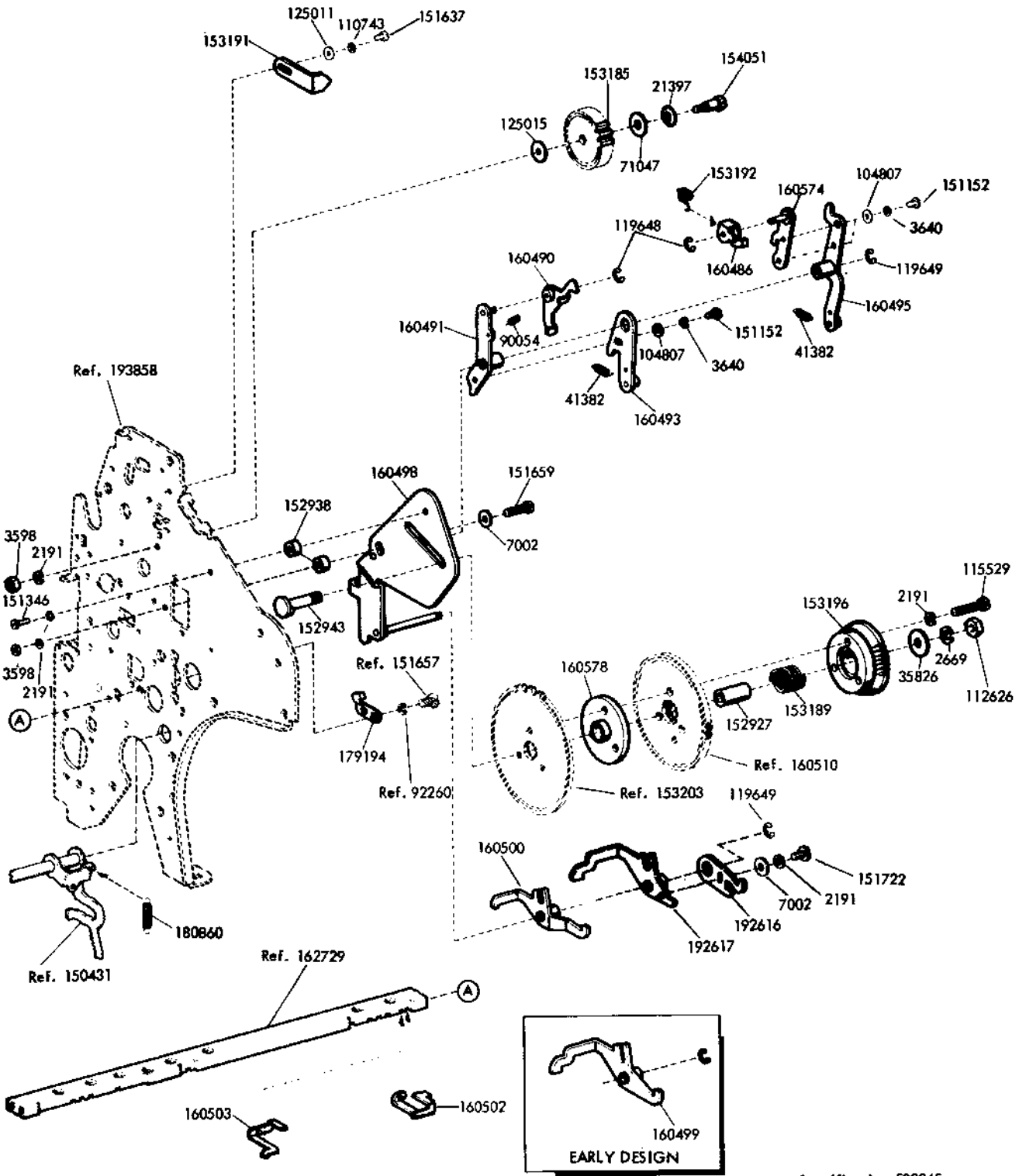

FIGURE 48. 154771 MODIFICATION KIT TO PROVIDE VERTICAL TABULATION

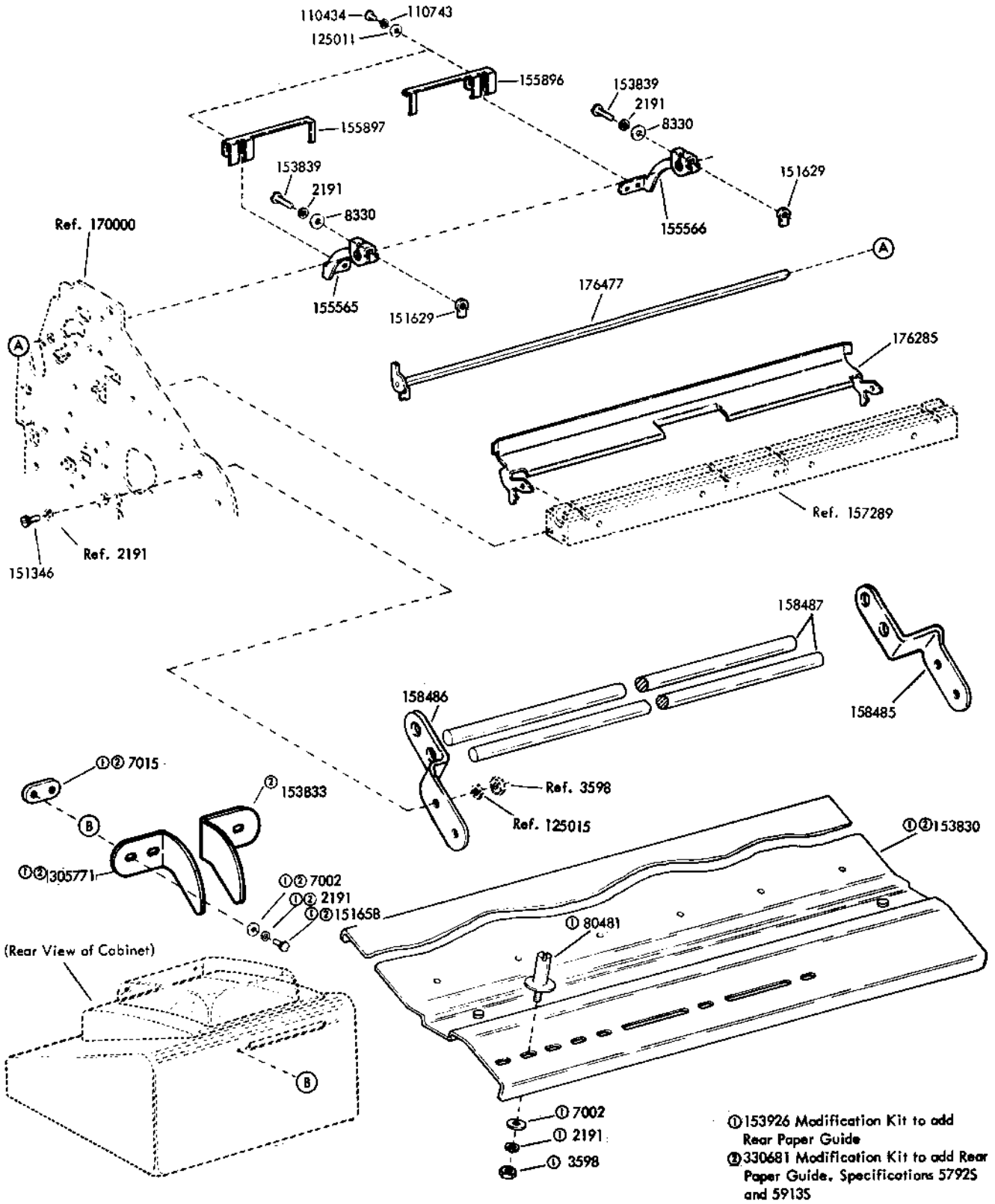

FIGURE 49. 154798 MODIFICATION KIT TO PROVIDE SUPERFOLD FRICTION. FEED PAPER HANDLING

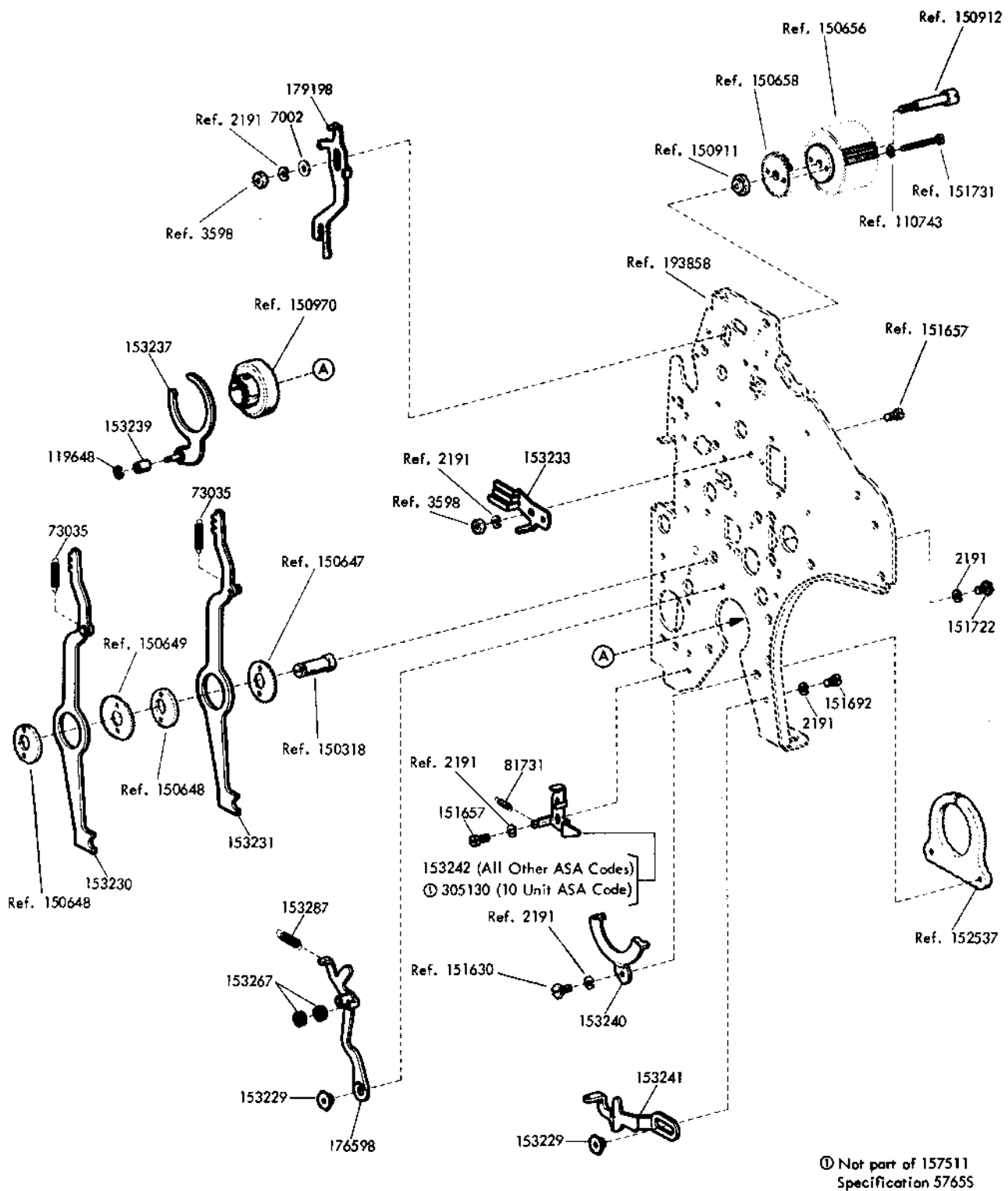

FIGURE 50. 157511 MODIFICATION KIT TO PROVIDE LOCAL REVERSE LINE FEED

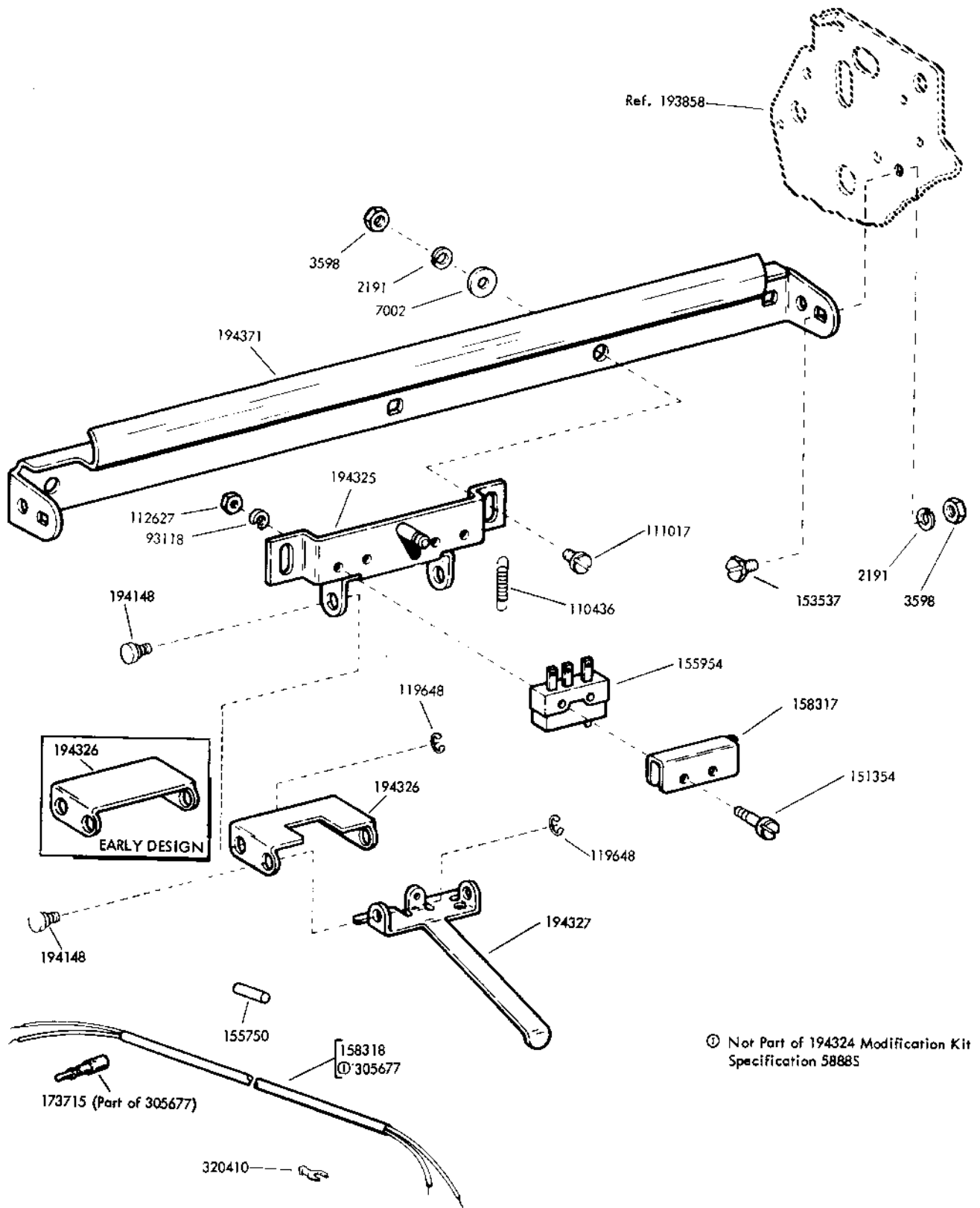

FIGURE 51. 194324 MODIFICATION KIT TO PROVIDE PAPER-OUT ALARM SWITCH

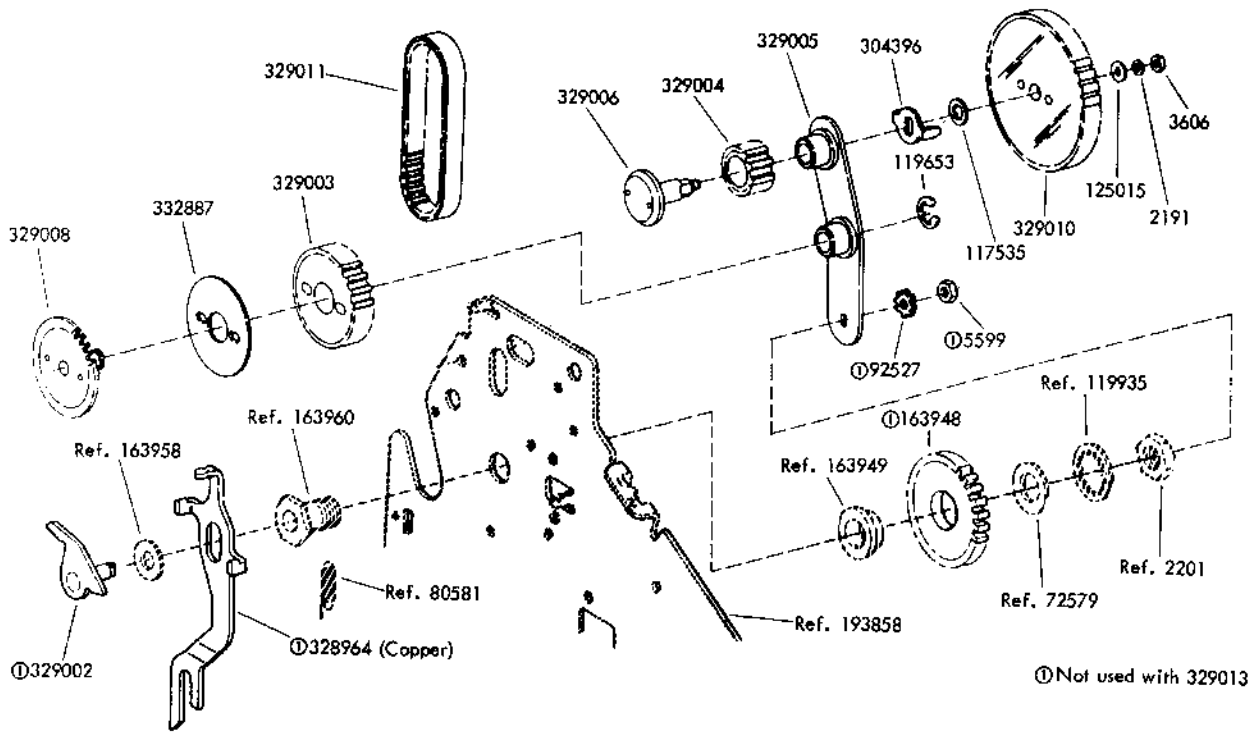

FIGURE 52. 329013 HANDWHEEL ASSEMBLY

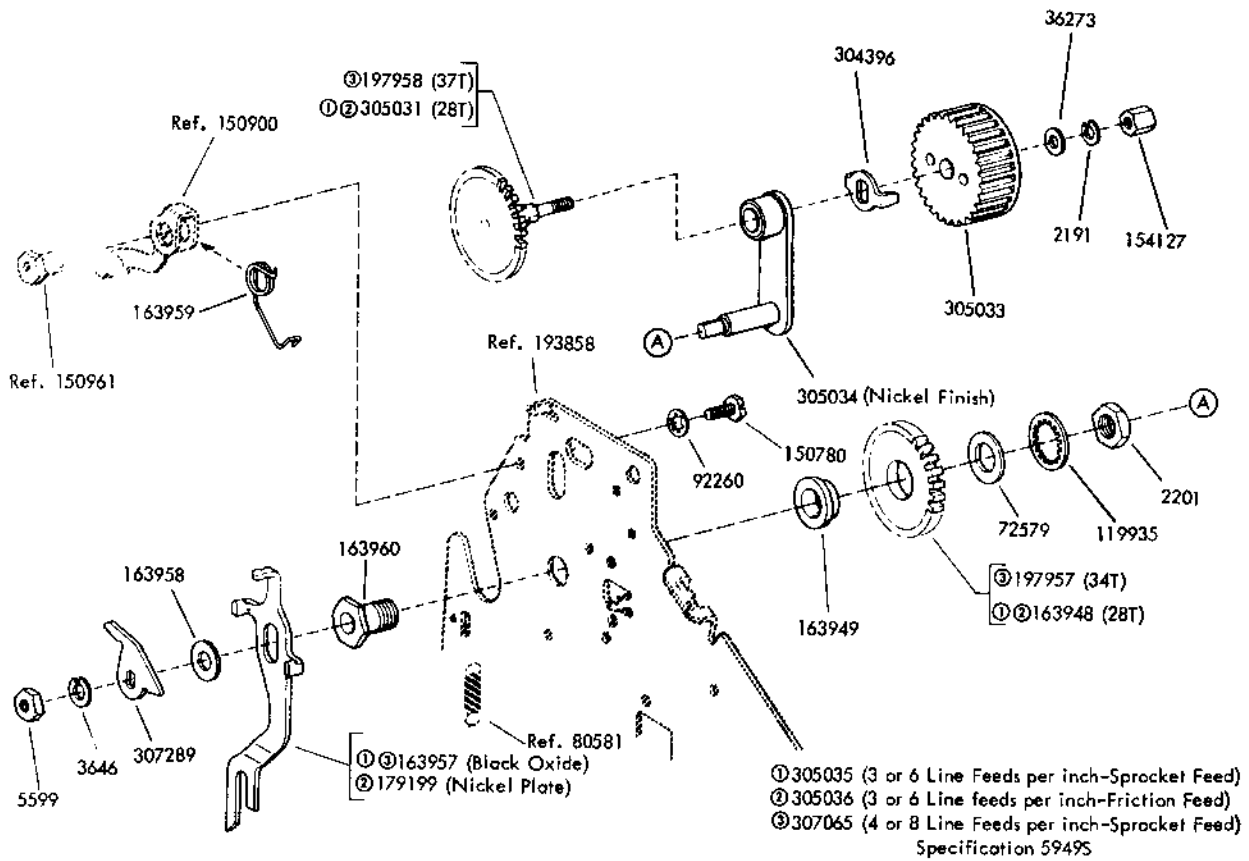
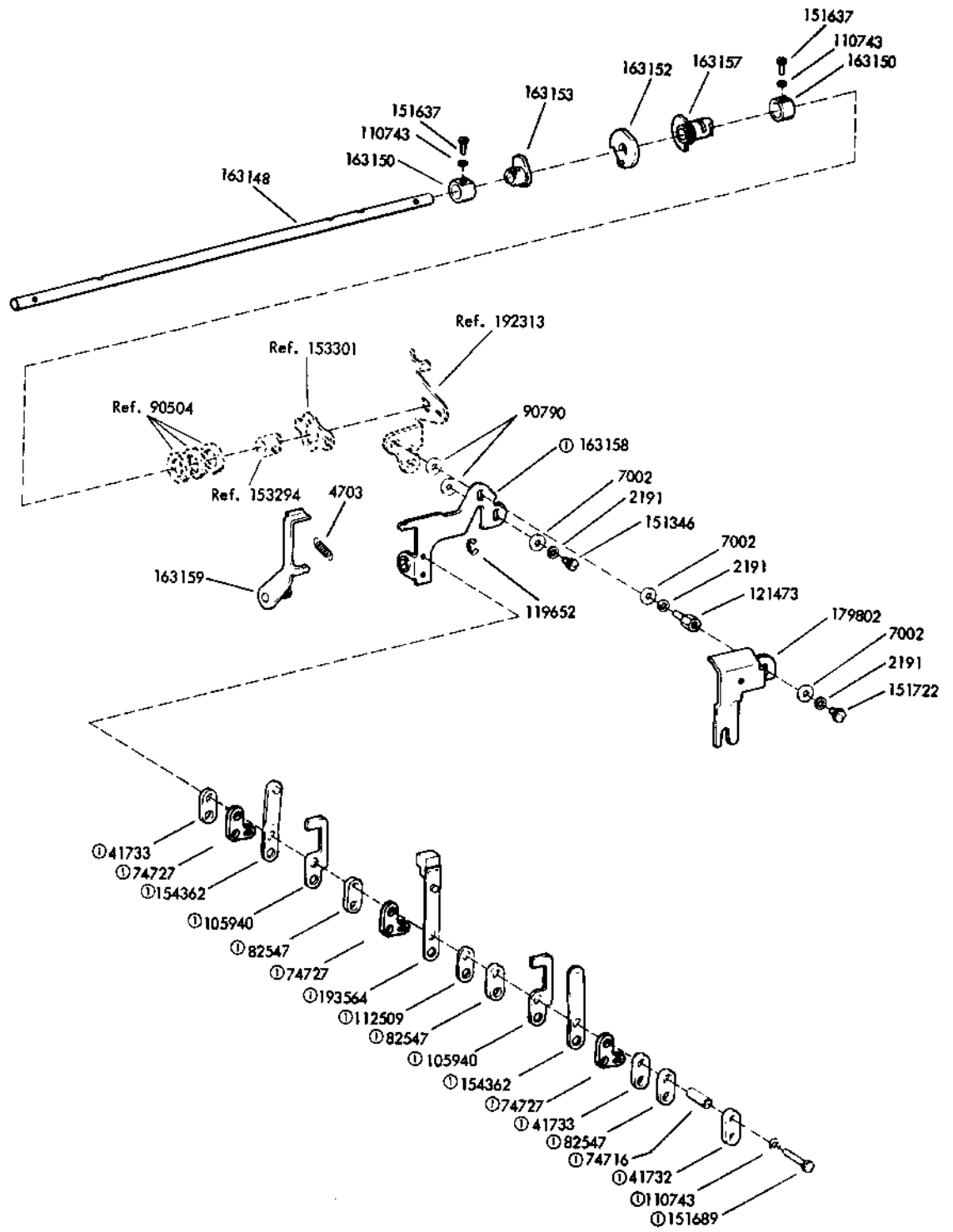

FIGURE 53. 305035, 305036, 307065 MODIFICATION KITS TO PROVIDE MANUAL PLATEN LINE FEED





①163147 Contact Assembly  
Specification 58045

FIGURE 54. 163146 MODIFICATION KIT TO PROVIDE UNIVERSAL CONTACT

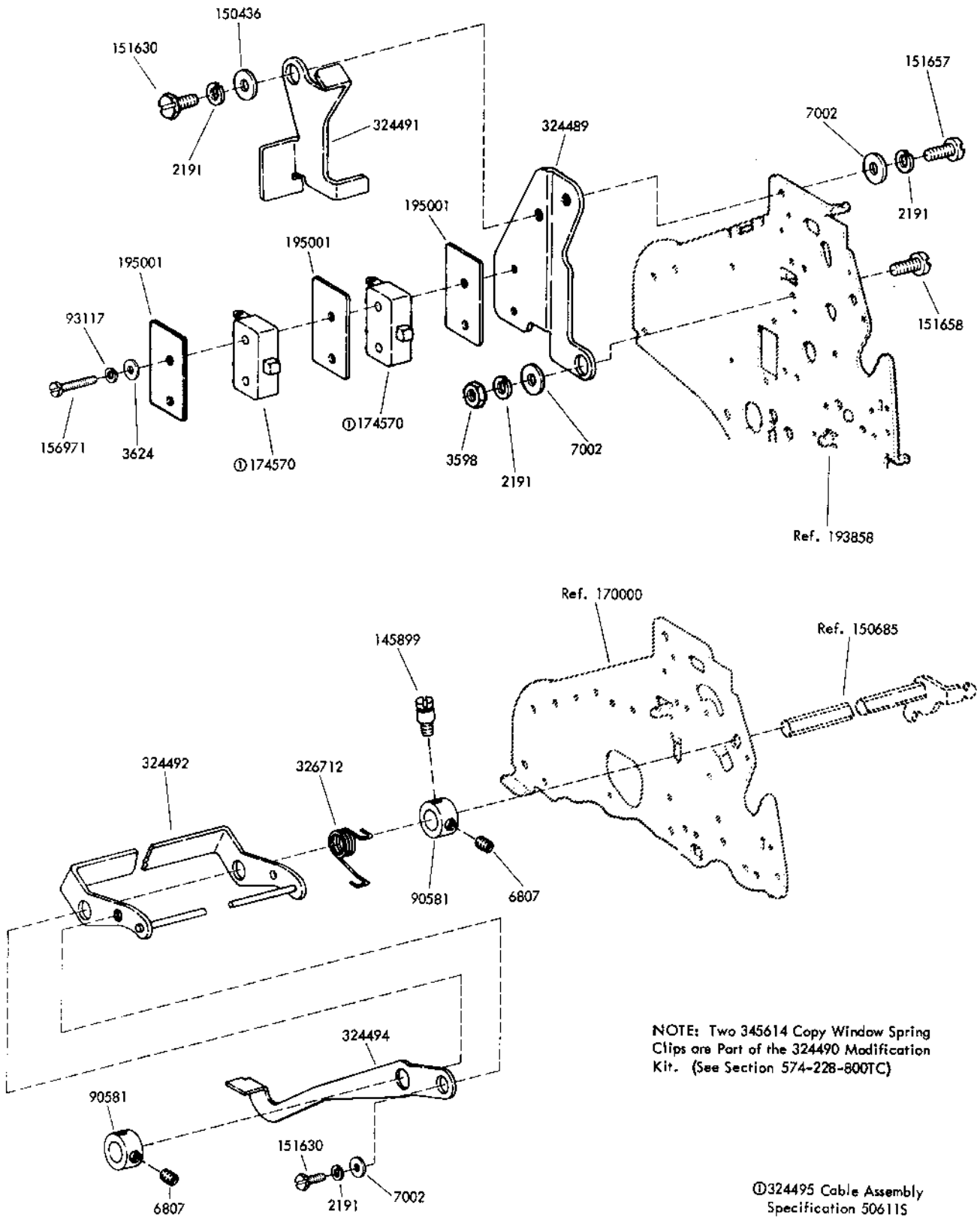

FIGURE 55. 324490 MODIFICATION KIT TO PROVIDE PAPER JAM ALARM

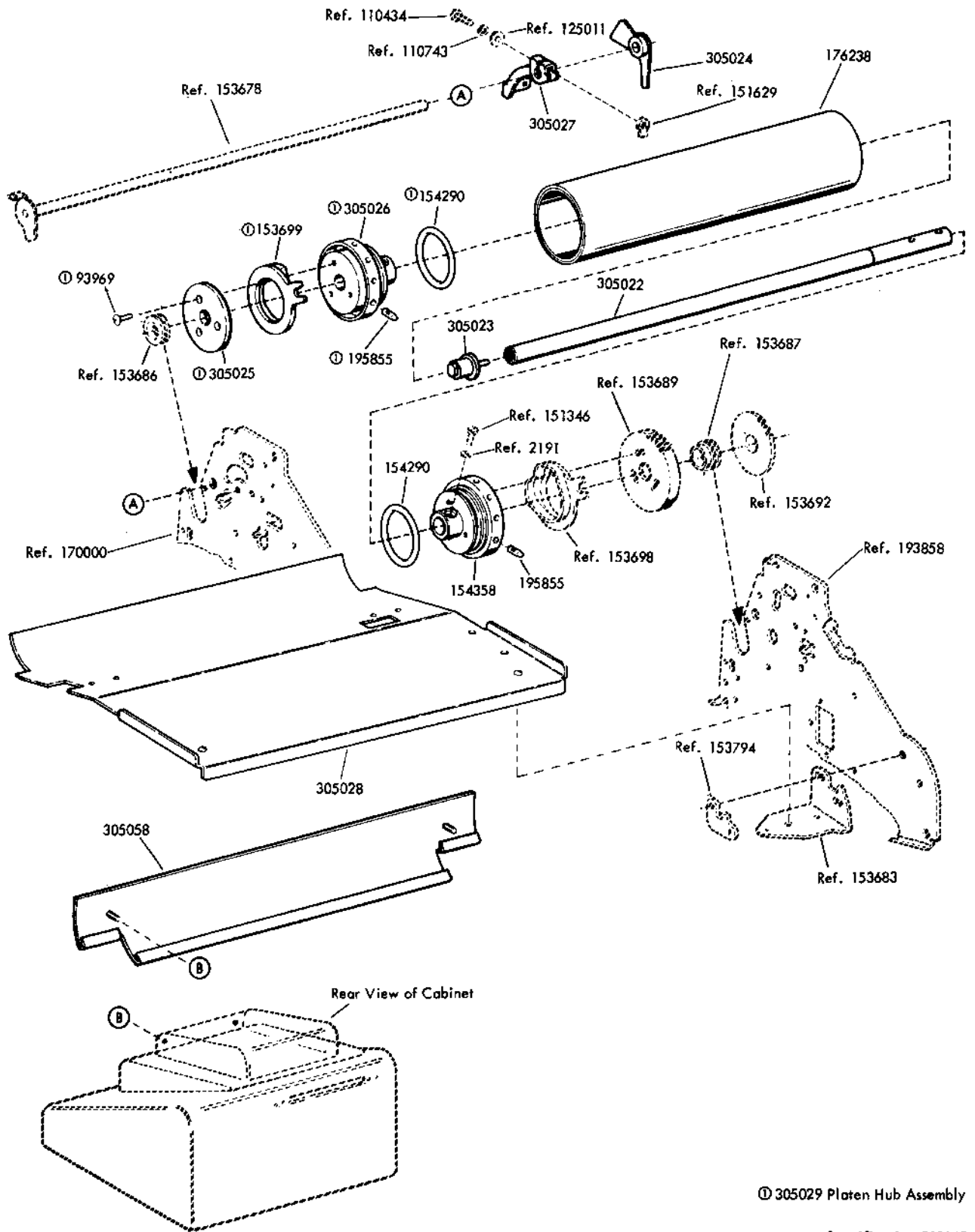

FIGURE 56. 305037 MODIFICATION KIT TO ADAPT SPROCKET FEED PRINTERS TO 9-1/2 INCH FORM WIDTHS

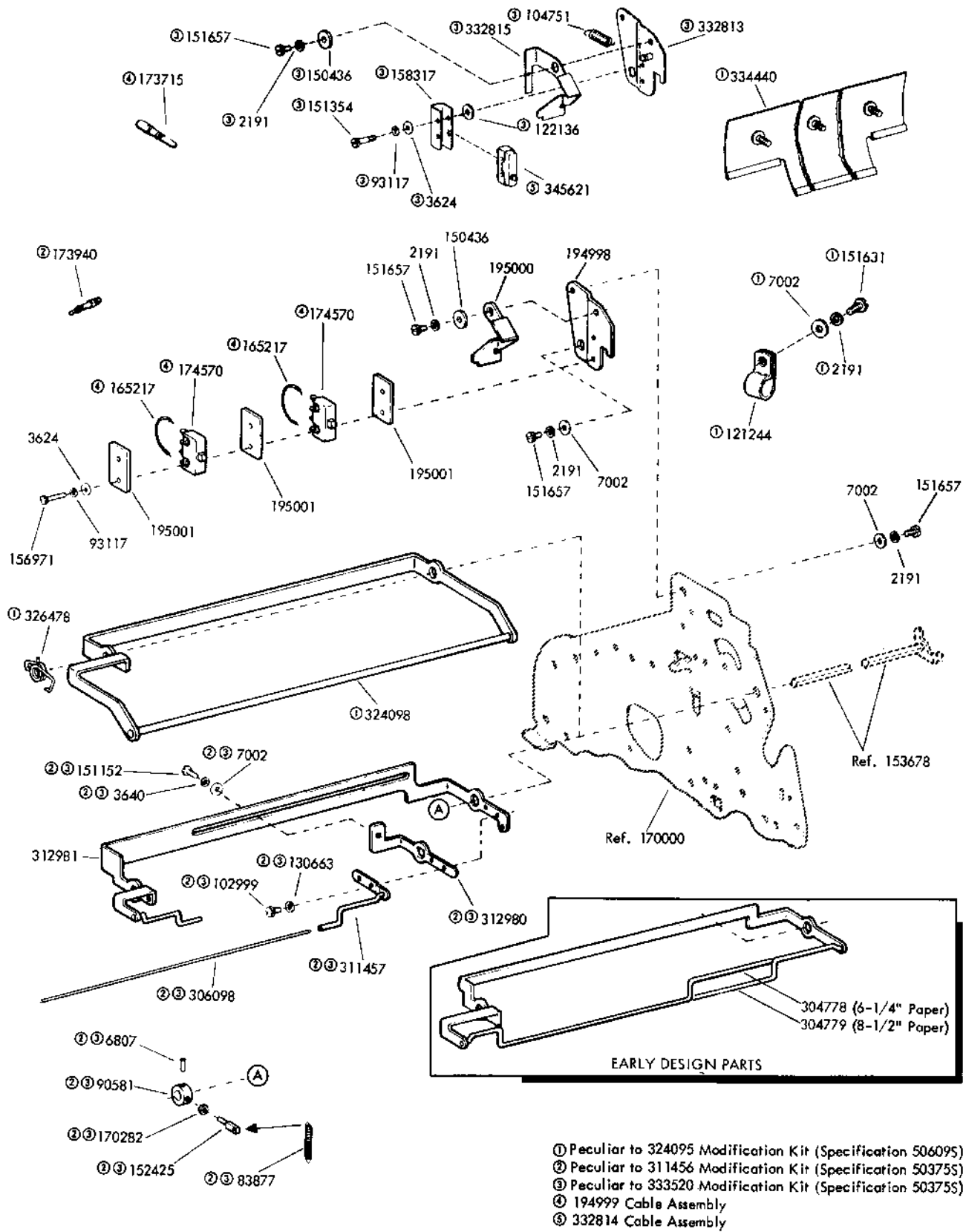
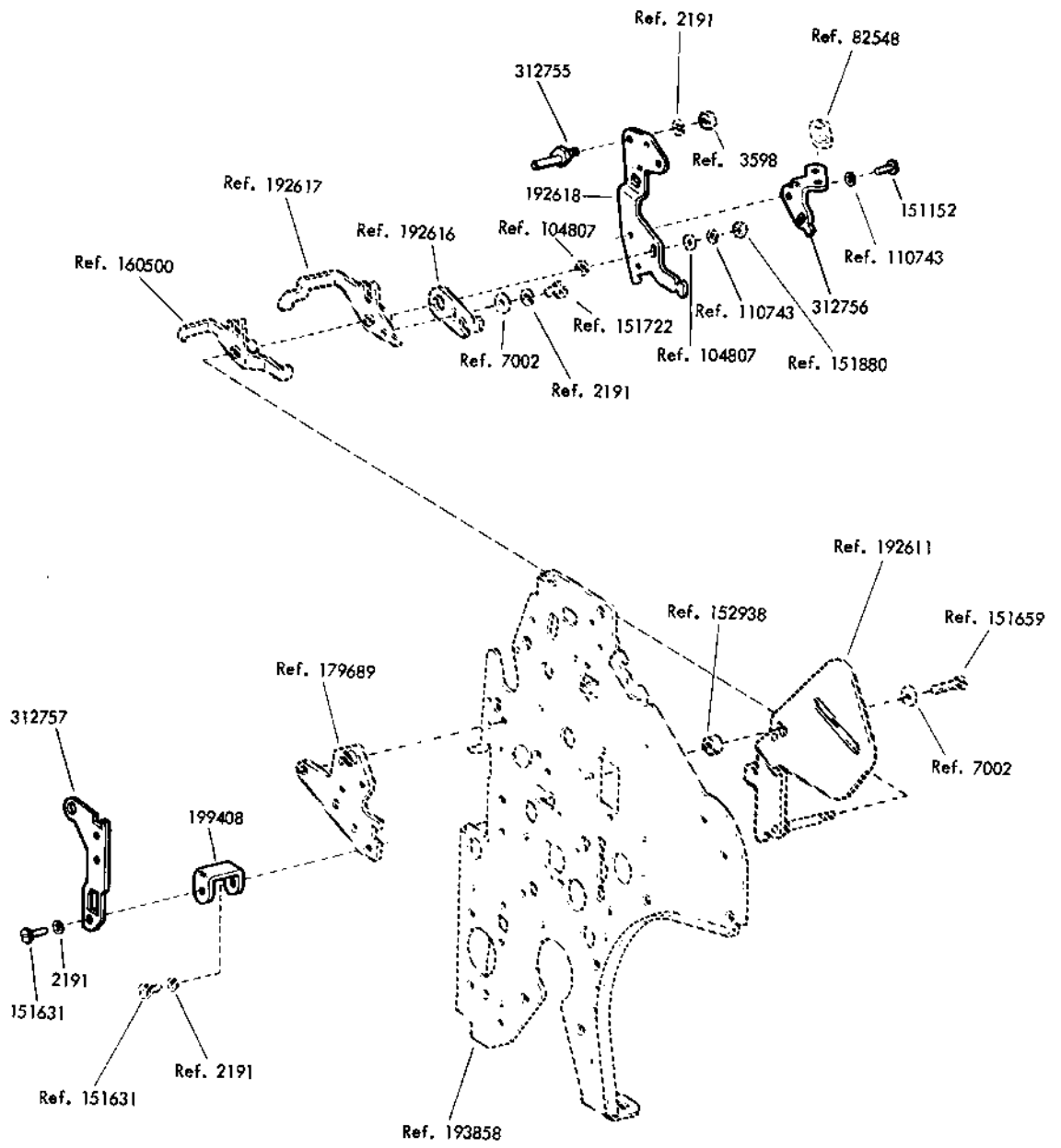
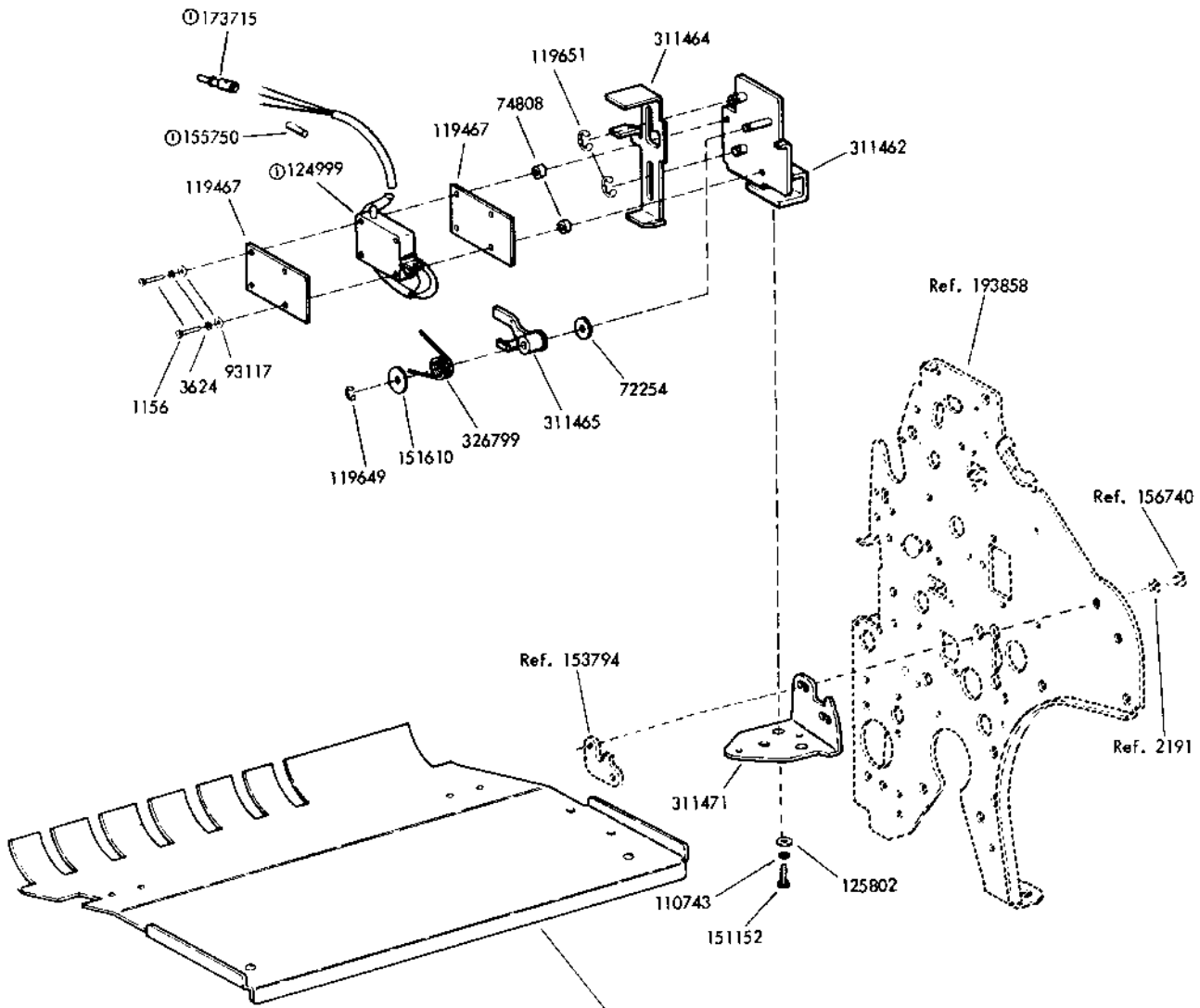

FIGURE 57. 311456, 324095 & 333520 MODIFICATION KITS TO PROVIDE PAPER JAM ALARMS



Specification 501505

FIGURE 58. 312711 MODIFICATION KIT TO ADAPT UNITS WITH A VERTICAL TABULATING MECHANISM TO USE THE 179724 MODIFICATION KIT



- ② 311466 (3-5/8", 4-1/2", 5-1/2", 6-1/2", 7-1/2" or 8-1/2" Platen)
- ③ 311467 (3", 4", 5", 6", 7", 8" or 9" Platen)
- ④ 311468 (4-1/4", 5-3/4" or 6-3/8" Platen)
- ⑤ 311469 (4-5/16" or 6-1/4" Platen)

- ① 311730 Cable Assembly
- ② Peculiar to 311458 Modification Kit
- ③ Peculiar to 311459 Modification Kit
- ④ Peculiar to 311460 Modification Kit
- ⑤ Peculiar to 311461 Modification Kit Specification 504685

FIGURE 59. 311458, 311459, 311460 AND 311461 MODIFICATION KITS TO ADD ADJUSTABLE LAST FORM ALARM

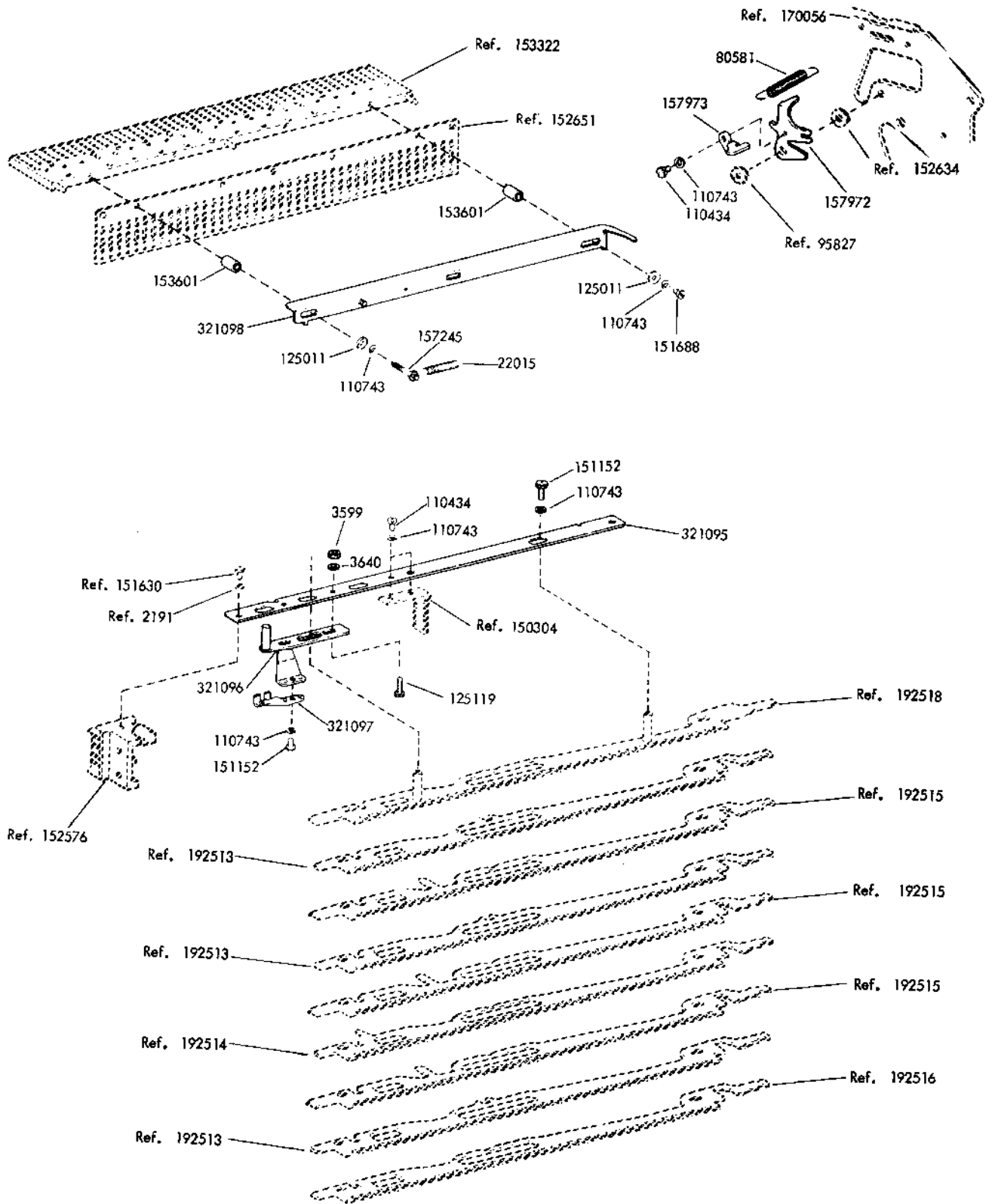

Specification 504715

FIGURE 60. 321099 MODIFICATION KIT TO PROVIDE AUTOMATIC CARRIAGE RETURN AND LINE FEED

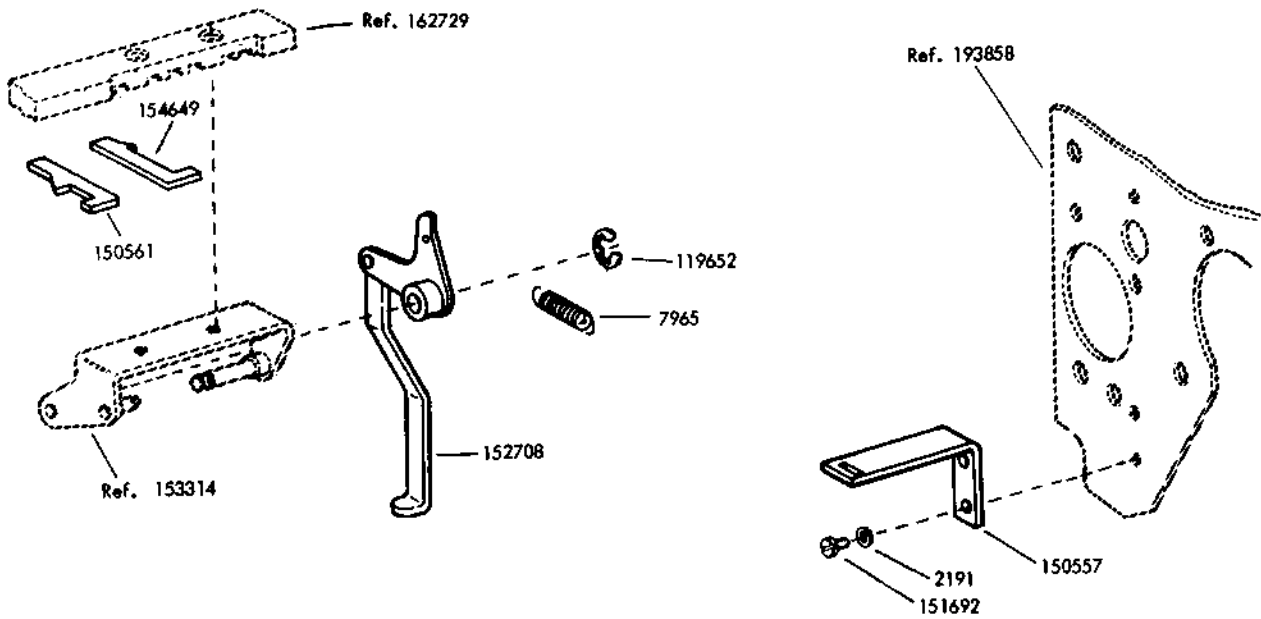

Specification 503345

FIGURE 61. 152350 MODIFICATION KIT TO PROVIDE KEYBOARD LOCK

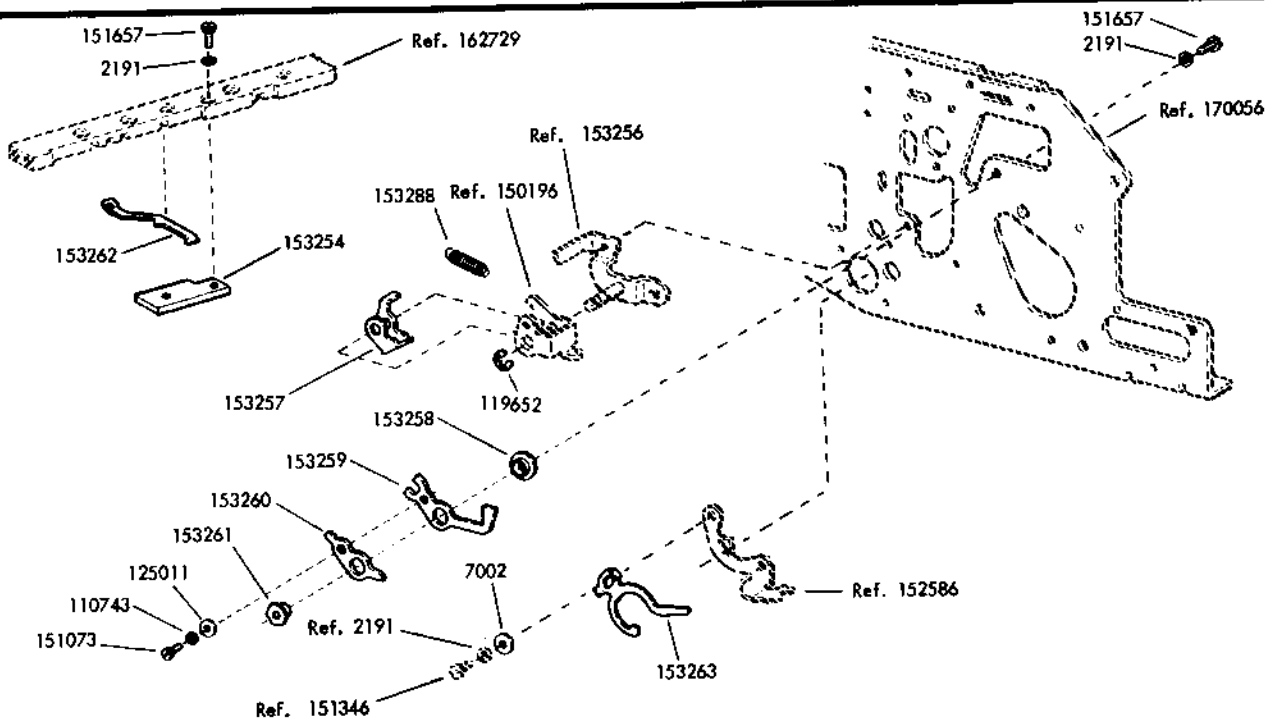

Specification 57665

FIGURE 62. 157510 MODIFICATION KIT TO PROVIDE LOCAL BACKSPACE



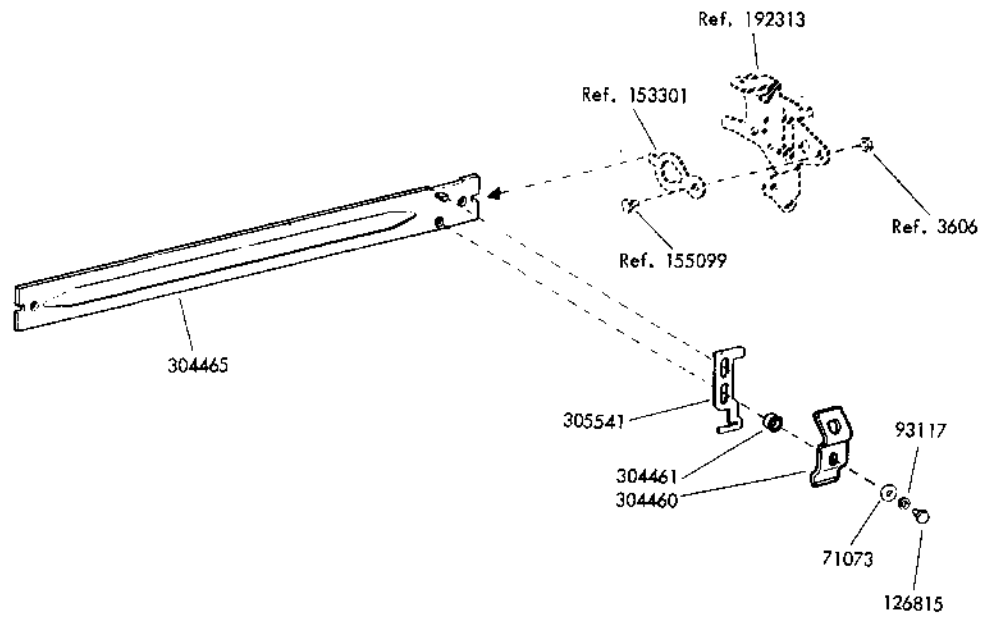

Specification 50352S

FIGURE 63. 305540 MODIFICATION KIT TO PROVIDE A YIELD MECHANISM FOR THE LINE FEED STRIPPER SLIDE (FUNCTION BOX SLOTS 39, 40 & 41)

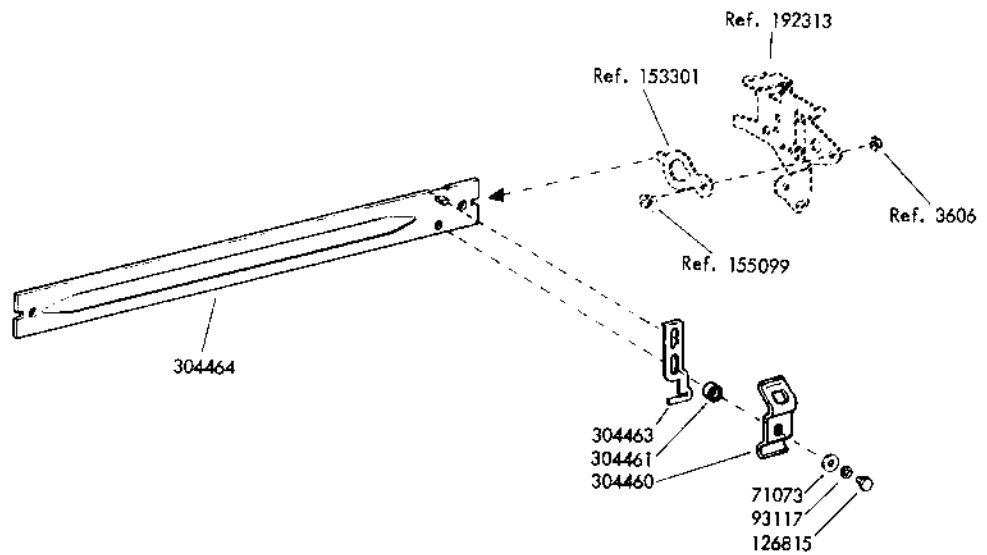

Specification 50352S

FIGURE 64. 305539 MODIFICATION KIT TO PROVIDE A YIELD MECHANISM FOR THE LINE FEED STRIPPER SLIDE (FUNCTION BOX SLOTS 39 & 40)

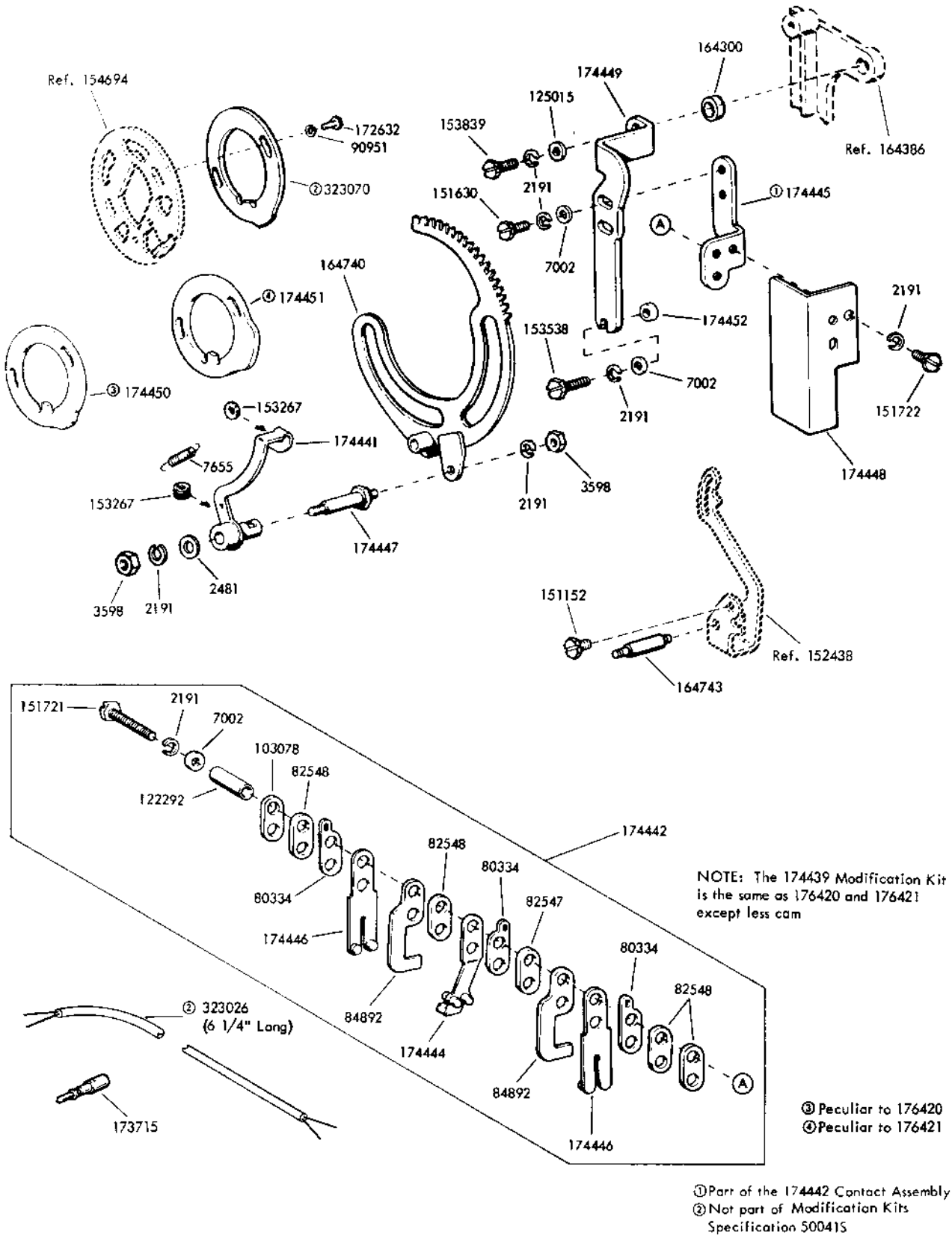

FIGURE 65. 176420, 176421 MODIFICATION KITS TO ADD TIMING CONTACTS FOR SELECTOR

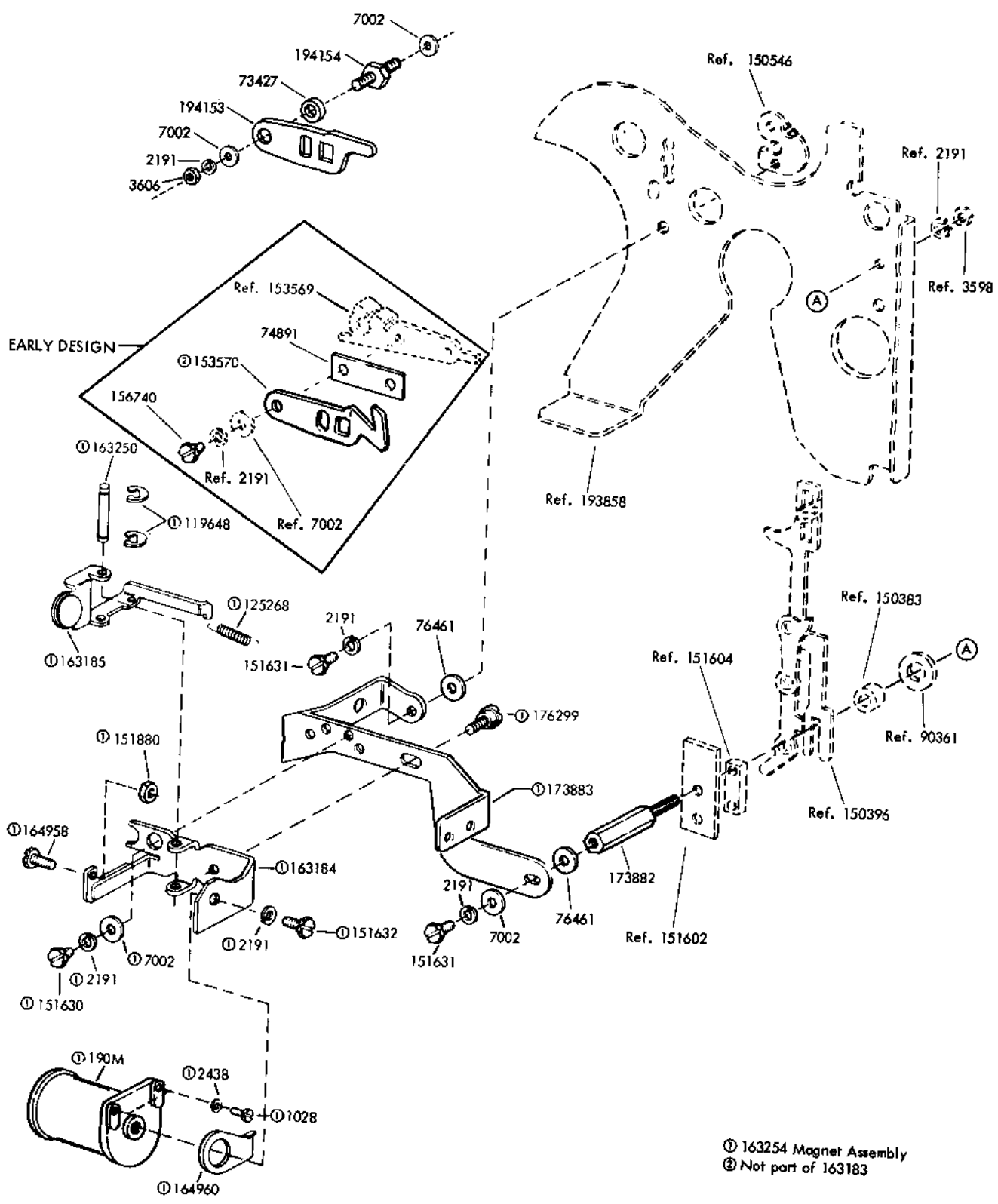
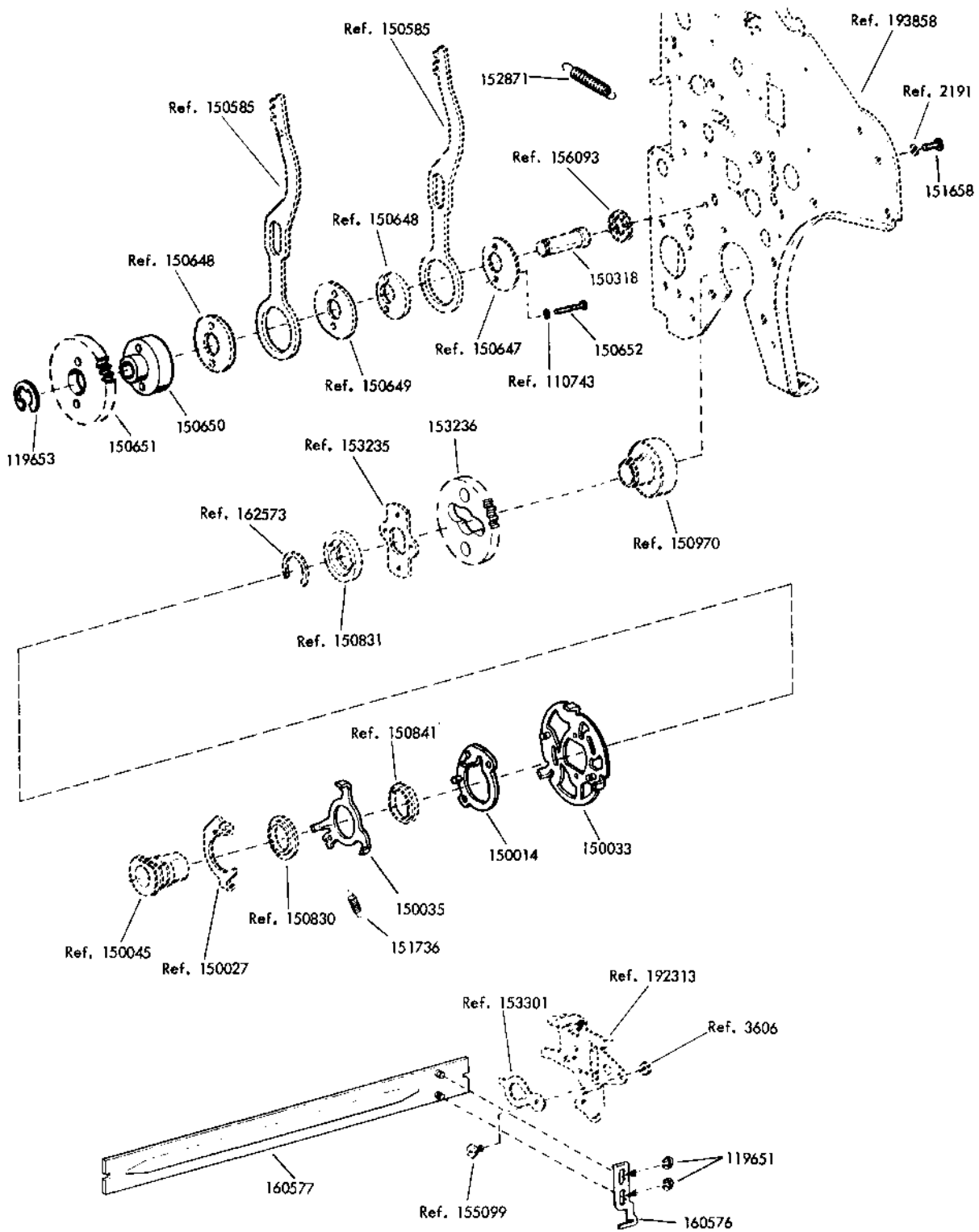

FIGURE 66. 163183 MODIFICATION KIT TO PROVIDE D.C. MAGNET OPERATED PRINT SUPPRESSION

Specification 59465



Specification 506035

FIGURE 67. 325967 MODIFICATION KIT TO CONVERT SPROCKET FEED PRINTER LINE FEED FROM 6.1 TO 3.1 RATIO (6 STOP TO 3 STOP CLUTCH)

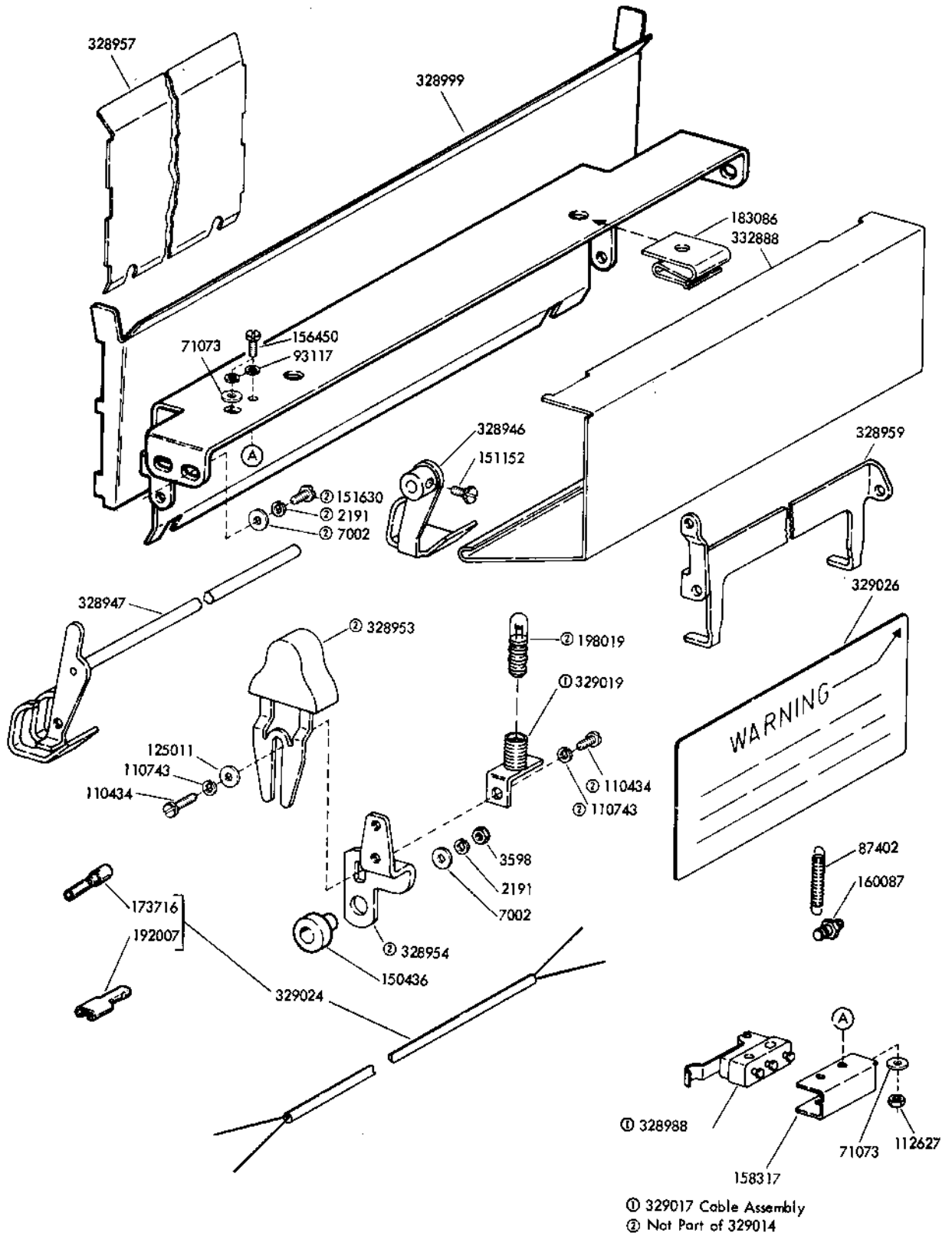

FIGURE 68. 329014 PAPER CHUTE ASSEMBLY

## NUMERICAL INDEX

Part Number	Description and Page Number	Part Number	Description and Page Number	Part Number	Description and Page Number
190M	Coil, Magnet 65	7001	Washer, Flat 32	71681	Spool, Ribbon 34
243M	Coil, Magnet 47,48	7002	Washer, Flat 5,10 to 15, 17 to 22,24 to 33,34,35, 36,37,41,47,48,50,51,52, 53,55,56,58,59,62,64,65, 67	72254	Washer, Flat 36,60
254M	Coil, Magnet 27			72468	Spring 6
271M	Coil, Magnet 27			72522	Wick, Felt 40
1028	Screw, 4-40 x 1/4 Fil 65			72579	Washer, Flat 54
1036	Nut, 6-40 Hex 36			73035	Spring 52
1156	Screw, 2-56 x 9/16 Fil 14,60	7015	Plate, Nut 51	73175	Lockwasher 7,10
1164	Screw, 2-56 x 3/16 Fil 31	7036	Collar, Locking 11	73427	Washer, Flat 10,65
1174	Screw, 4-40 Shoulder 28	7603	Spring 10,22,37	73520	Wick, Felt 19
1178	Screw, 2-56 x 7/16 Fil 8	7655	Spring 26,36,64	74011	Screw, 6-40 Shoulder 13
1214	Setscrew, 10-32 19	7835	Ribbon w/Spool, Black 33	74283	Washer, Spring 25,26
1293	Screw, 4-40 x 1/8 Fil 33	7965	Spring 62	74536	Setscrew, 6-40 11
2034	Washer, Flat 8,25,29	8330	Washer, Flat 8,10,25,29, 35,37,38,47,48,51	74547	Collar 10
2191	Lockwasher 3 to 38,41,45 to 48,50 to 61,62,64,65, 66,67	8449	Spacer, .094" Thk 10,33	74553	Wick, Felt 17
2201	Nut, 5/16-32 Hex 54	13681	Spacer, .187" Thk 32	74701	Spring 6,10,49
2438	Washer, Flat 27,65	21397	Washer, Spring 12,13,50	74707	Spring 11
2481	Washer, Flat 26,64	22015	Spring 33,61	74716	Bushing, Insulating 14,55
2539	Nut, 3/8-32 Hex 7,10	27425	Screw, 2-56 x 5/32 Fil 17	74717	Screw, 4-40 x 23/32 Fil 14
2669	Lockwasher 5,7,11,12,13, 17 to 21, 23,24,25,36, 37,50	31636	Spring 37	74722	Washer, Flat 8,9,11
3438	Washer, Flat 20	33038	Spring 11	74727	Terminal, Contact 55
3598	Nut, 6-40 Hex 5 to 13,15, 16,17,18,19,21,23,25,26, 28,29,30,32,35,36,50,51, 52,53,56,59,64,65,67	33828	Spring 17,18	74755	Washer, Felt 24
3599	Nut, 4-40 Hex 6,10,14,19, 22,25,26,27,33,40,47,48, 49,61	34432	Washer, Flat 7,14	74760	Spring 32
3606	Nut, 6-40 Hex 5,9,10,23, 28,36,38,54,63,65,66	35826	Washer, Flat 12,50	74785	Roller 10
3624	Washer, Flat 31,32,56, 58,60	36273	Washer, Flat 23,54	74798	Screw, 6-40 x 31/64 Fil 7
3640	Lockwasher 8,11 to 16,20 21,26,29,31,41,47,48,50,58,61	36463	Spring 23	74807	Nut, 10-32 Shoulder Hex 13
3646	Lockwasher 28,41,54	41382	Spring 12,13,25,26,50	74808	Bushing 60
3649	Washer, Flat 29,30	41675	Washer, Flat 36	74882	Spring 17
3650	Washer, Flat 28	41732	Plate, Clamp 14,36,37, 41,55	74891	Shim, .004" Thk 65
4586	Washer, Felt 11	41733	Insulator, .062" Thk 55	76081	Washer, Flat 27
4703	Spring 36,42,55	42661	Spring 33,34,47,48	76099	Washer, Flat 27
5599	Nut, 8-32 Hex 54	42823	Washer, Flat 15,16	76461	Washer, Flat 13,21,65
5740	Screw, 2-56 x 1/4 Fil 38	42827	Screw, 3-48 x 1/4 Fil 27, 37	76474	Nut, 10-32 Hex 11
5816	Washer, Insulating 41	45024	Spring 47,48	76790	Bushing, Insulating 14
6800	Screw, 6-40 Shoulder 10	45027	Spring 19,20	76800	Spring 8
6807	Setscrew, 6-40 56,58	45815	Lockwasher 14	76834	Screw, 4-40 x 3/8 Flat 31 45
6835	Washer, Flat 13	49420	Spring 35	77039	Bushing, Insulating 41
		55063	Spring 8	79012	Insulator 27
		55669	Spring 47,48	79449	Shim, .008" Thk 20
		70388	Spring 10	80310	Washer, Felt 24
		70466	Spring 22,38	80334	Terminal, Contact 14,26, 36,64
		70529	Stiffener 14,36	80424	Spring 13
		70886	Washer, Flat 11	80481	Screw, 6-40 Spl 51
		71047	Washer, Flat 12,13,50	80581	Spring 9,11,20,54,61
		71073	Washer, Flat 8,63,67	80755	Bushing, Insulating 14
		71440	Washer, Flat 13	80848	Spring 9

## NUMERICAL INDEX (Continued)

Part Number	Description and Page Number	Part Number	Description and Page Number	Part Number	Description and Page Number
80854	Screw, 6-40 x 1-7/16 Fil 41	92736	Post, Spring 22	110435	Nut, 4-40 Hex 13,29,30, 31
81726	Terminal 37,41	93117	Lockwasher 8,31,32,47, 48,56,58,60,63,67	110436	Spring 53
81731	Spring 19,52	93118	Lockwasher 14,36,53	110437	Spring 10
81773	Screw, 4-40 x 29/32 Fil 37	93191	Screw, 6-40 x 5/16 Flat 31	110743	Lockwasher 4 to 9,13 to 22,24 to 29,31,33 to 41, 43,47 to 52,55,57,59 to 62,66,67
81778	Screw, 4-40 x 3/16 Fil 27	93356	Washer, Felt 7,10,16,17, 18,19,22,35	110872	Spring, Compression 19
82442	Spring 11	93507	Screw, 4-40 x 3/4 Hex 38	110879	Spring 36
82463	Spring 11,33,34,47	93729	Wick, Felt 29,35	111017	Screw, 6-40 x 5/16 Fil 53
82547	Insulator, .094" Thk 14,26,36,41,55,64	93758	Washer, Felt 10,11,29	111342	Spring 36
82548	Insulator, .062" Thk 14,26,36,37,41,59,64	93879	Oiler, Felt 11	111355	Spring, Compression 11
82725	Spring 28	93899	Spring 47,48	112509	Insulator, .031" Thk 55
83877	Spring 58	93969	Screw, 4-40 x 3/16 Flat 8,57	112626	Nut, 10-32 Hex 5,12,17, 18,19,21,24,25,37,50
83913	Spring, Contact 37	94248	Clamp, Cable 19	112627	Nut, 2-56 Hex 21,47,48, 53,67
83914	Spring, Contact 37	94674	Washer, Cup 35	112629	Spring 36
84575	Spring 11	95030	Nut, 6-40 Shoulder 7	112633	Spring w/Wick 35
84705	Spring, Contact 37	95827	Bushing 20,61	112634	Spring 33,34
84758	Spring 36	96717	Screw, 4-40 Shoulder 25	112935	Setscrew, 6-40 28
84892	Stiffener 14,26,36,64	97117	Ribbon w/Spool, Red-Black 48	113990	Washer, Flat 5
85407	Spring, Compression 7	97481	Wick, Felt 7	114107	Spring 29
85816	Wick, Felt 21	98142	Washer, Flat 28	115122	Washer, Felt 17,18
86304	Spring 11	98832	Screw, 4-40 x 11/16 Fil 14,36	115529	Screw, 6-40 x 11/16 Fil 12,46,50
86746	Screw, 6-40 Shoulder 5	98833	Screw, 4-40 x 31/32 Fil 37	116951	Bushing, Insulating 36
86835	Spring 3,23	101796	Washer, Felt 11,17,19,20,35	117535	Washer, Flat 54
87401	Spring 36	102672	Spring, Contact 14	119451	Spacer 13
87402	Spring 67	102673	Spring, Contact 14	119467	Insulator, .032" Thk 31, 32,60
89096	Washer, Felt 21	102999	Screw, 2-56 x 5/32 Fil 58	119648	Ring, Retaining 12,13,17, 23,25,26,28,30,41,47 48,50,52,53,65
89897	Nut, 10-32 Hex 19	103078	Plate 26,64	119649	Ring, Retaining 9,11,13, 14,20,22,29,31,33,34,36, 38,40,47,48,50,60
90054	Spring 12,13,50	103966	Spacer 31	119650	Ring, Retaining 5,28
90361	Washer, Felt 5,11,17,18, 33,34,47,48,65	104751	Spring 58	119651	Ring, Retaining 6,11,17, 18,20,21,22,33,34,35,36, 37,38,47,48,60,66
90490	Shim, .005" Thk 11	104807	Washer, Flat 12,13,14,41, 50,59	119652	Ring, Retaining 7,10,11, 13,15,17,18,19,21,22,23, 25,26,29,32,33,34,35,36, 47,48,55,62
90504	Washer, Felt 21,38,55	104824	Spring 27	119653	Ring, Retaining 9,11,19, 20,23,33,34,36,38,47,48, 54,66
90517	Spring 40	105028	Wick, Felt 23		
90581	Collar 56,58	105940	Stiffener 55		
90599	Shim, .008" Thk 35	106281	Screw, 4-40 Shoulder 41		
90679	Washer, Felt 11	107116	Lockwasher 4		
90752	Washer, Felt 20	107207	Spring, Contact 14,36		
90790	Washer, Flat 8,26,45,55	107236	Bushing 36		
90791	Lockwasher 17	108103	Washer, Flat 13		
90819	Washer, Felt 7,10	108199	Wick, Felt 9,10,35		
90951	Lockwasher 15,64	110434	Screw, 4-40 x 3/16 Fil 4,5,8,16,20,21,25,37,43, 51,57,61,67		
91198	Wick, Felt 17,18				
92260	Lockwasher 11,12,50,54				
92527	Lockwasher 54				
92682	Nut, 4-40 Spl 29				

## NUMERICAL INDEX (Continued)

Part Number	Description and Page Number	Part Number	Description and Page Number	Part Number	Description and Page Number
119654	Ring, Retaining 30	144871	Shaft, Solenoid Plunger 28	150091	Gear, 27T 16
119935	Lockwasher 54			150096	Roller Assembly, Pressure 6
120824	Washer, Felt 15	144932	Solenoid 28	150175	Stud 23
121243	Clamp, 3/16 ID Cable 4,7,27,28	145301	Latch 40	150184	Link 19
121244	Clamp, 1/4 ID Cable 7,27, 29,58	145321	Tie, Cable 32	150193	Hub 19
121245	Clamp, 5/16 ID Cable 7,47	145466	Spring, Compression 13	150194	Plate 19
121248	Clamp, 1/2 ID Cable 27	145899	Post, Spring 56	150196	Bail 19,62
121249	Clamp, 5/8 ID Cable 27	150000	Drum, Clutch 15,16	150197	Stud 21,24
121473	Post 55	150001	Drum, Clutch 15	150202	Gear, 18T 20
122136	Spacer, .040" Thk 58	150010	Plate, Retaining 16	150203	Retainer 20
122292	Bushing, Insulating 26,64	150013	Disc, Adjusting 15,16	150206	Spacer, .412" Thk 24
124244	Washer, Felt 29	150014	Disc, Adjusting 16,66	150214	Stud, Bearing 11
124276	Screw, 4-40 x 1-3/64 Fil 36	150025	Clutch Assembly, Type Box 16	150215	Block, Guide 23
124681	Setscrew, 6-40 6	150026	Lever, Shoe Release 15,16	150218	Bushing 22
124999	Switch, Sensitive 31,60	150027	Lever, Shoe Release 16,66	150219	Screw, 4-40 x 1/2 Sq 22
125005	Screw, 2-56 x 3/16 Rd 21	150029	Wick, Felt 15,16	150224	Pulley 21
125011	Washer, Flat 5 to 8,11 12,14,17,18,19,22,24,25, 26,31,35,39,41,43,47 to 51,57,61,62,67	150030	Roller, Bearing 35	150225	Rope, Draw Wire 24
125015	Washer, Flat 4,6,7,9 to 12,17,27,36,47,50,51,54, 64	150033	Disc, 3 Stop 16,66	150228	Spacer, .035" Thk 19
125112	Screw, 2-56 x 1/8 Fil 36	150035	Disc, 3 Stop 16,66	150229	Retainer 19
125119	Screw, 4-40 Shoulder 61	150038	Latch 35	150230	Plate 35
125181	Screw, 2-56 x 3/8 Fil 31	150039	Slide, Printing Arm 35	150232	Retainer, Oil 23
125238	Spring 19	150040	Screw, 6-40 x 5/8 Fil 8,10,48	150233	Roller 19
125241	Spring 27	150043	Shoe, Secondary Clutch 15,16	150234	Roller 19
125268	Spring 65	150044	Shoe, Primary Clutch 15,16	150235	Slide, Transfer 19
125390	Washer, Flat 41	150045	Bearing, Clutch Sleeve 16,66	150237	Lever, Escapement 21
125790	Bushing 37	150046	Bearing, Type Box Clutch 16	150241	Spring 15,16
125802	Washer, Flat 13,19,60	150047	Bearing, Code Bar Clutch 15	150244	Link 16,18
126250	Screw, 8-32 x 1/4 Fil 41	150048	Spring 25	150245	Bracket 23
126815	Screw, 2-56 x 15/64 Hex 47,48,63	150050	Spacer, Clutch 15	150247	Link 23
128357	Ring, Retaining 8	150051	Cam, Eccentric 15	150251	Wheel, Ratchet 24
129505	Screw, 8-32 x 3/16 Rd 28	150053	Bracket 35	150255	Bushing 21
130663	Lockwasher 58	150054	Bail w/Roller 35	150265	Shaft 6
130683	Lockwasher 22	150055	Stud 29	150266	Lever, Guide 6
130696	Washer, Felt 37	150056	Arm 15,29	150267	Clamp 6
131316	Wick, Felt 23	150059	Bail 35	150269	Roller, Pressure 6
136470	Bushing, Insulating 37	150061	Head, Print Hammer 35	150270	Link 6
138034	Plate, Clamp 14	150064	Stud 35	150271	Arm, Release 6
143097	Ring, Retaining 38	150065	Bracket, Stop 35	150274	Bracket, Clamp 6
144540	Screw, 4-40 x 1-1/8 Fil 36	150068	Arm 35	150276	Lever 6
		150078	Nut, 4-40 Shoulder Hex 43	150289	Stud 37
		150079	Stud 43	150293	Plate, Retaining 37
		150089	Screw, 4-40 x 1/2 Fil 20,27,41,47,48	150301	Plate, Retaining 37
				150302	Shim, .006" Thk 37
				150304	Bracket, Guide 37,61
				150310	Lever, Ribbon 33
				150311	Lever, Ribbon 34
				150318	Stud 9,52,66
				150335	Gear, 12T 33
				150336	Bushing 19,33,34,47,48



## NUMERICAL INDEX (Continued)

Part Number	Description and Page Number	Part Number	Description and Page Number	Part Number	Description and Page Number
150341	Post, Spring 5	150432	Washer, Flat 28,48	150677	Pawl, Feed 20
150342	Screw, 6-40 Shoulder 8,9	150436	Bushing 6,8,19,33,56,58,67	150678	Pawl, Feed 20
150343	Lever 33,48	150440	Hub 16	150685	Plate 6,56
150344	Lever 34,47	150441	Gear, 21T 16	150689	Block, Guide 38
150348	Shaft 10	150444	Lever, Trip Shaft 10	150705	Bushing 21
150350	Shaft 10	150447	Arm 29	150709	Spacer 21
150351	Stud, Eccentric 5	150450	Arm 29	150710	Screw, 6-40 x 1-1/4 Fil 21
150352	Bushing 10	150471	Stud 29,30	150711	Washer, Flat 36
150353	Stud 5	150479	Stud 11,25	150712	Rope, Draw Wire 24
150355	Lever, Latch 10	150481	Shaft 29,30,49	150714	Bearing, Sleeve 9
150356	Lever, Trip 10	150482	Plate 29,30	150715	Gear, 32T 9
150358	Lever, Trip 10	150507	Spring 29,30	150718	Platen 9
150361	Spacer, .277" Thk 10	150535	Spring, Compression 37	150719	Retainer 5
150363	Plate 18	150536	Spring 19	150720	Retainer 4
150364	Stud, Eccentric 16,18	150537	Ball, Bearing 19,37	150721	Arm 21
150365	Shaft, Rocket 17,18,23	150538	Cylinder, Dashpot 19	150722	Arm 21
150366	Bracket 16,18	150543	Screw, 3-48 x 13/32 Fil 38	150728	Rail 21
150367	Bracket 17	150544	Handle 38	150731	Slide 19
150369	Link, Left 18	150545	Bracket, Right 4	150732	Slide, Bottom 19
150370	Link, Right 17	150546	Bracket, Left 5,65	150733	Slide, Top 19
150377	Arm 11	150547	Shaft 38	150738	Guide 19
150380	Stud 17	150549	Collar 16	150746	Bushing 20
150382	Block, Guide 17,18	150554	Plate 21,24	150748	Stud 23
150383	Spacer, .149" Thk 18,65	150557	Bracket 62	150750	Plate 21
150384	Spacer, .245" Thk 17	150561	Arm 62	150751	Block, Guide 21
150386	Link, Left Ribbon Drive 18,48	150563	Spring 26,29	150752	Stud 22
150387	Link, Right Ribbon Drive 17,47	150585	Bar, Line Feed 9,66	150753	Roller 22
150392	Bail 11	150586	Lever 9	150754	Roller 23
150395	Screw, 6-40 Shoulder 17,18	150598	Track, Printing 23	150755	Stud 23
150396	Lever, Left 18,65	150642	Bellcrank 9	150758	Pulley 23
150397	Lever, Right 17	150646	Screw, 6-40 Shoulder 9	150770	Bellcrank 20
150398	Stud, Pivot 7	150647	Eccentric 9,52,66	150771	Bellcrank 20
150399	Shaft 11	150648	Eccentric 9,52,66	150780	Screw, 6-40 Spl 54
150401	Clamp 18	150649	Washer, Spacing 9,52,66	150781	Stud 11
150410	Stud 18	150650	Bushing 9,66	150796	Disc 24
150411	Washer, Flat 17,31	150651	Gear, 28T 9,66	150798	Ratchet 24
150412	Arm, Left Follower 18	150662	Screw, 4-40 x 37/64 Fil 9,66	150800	Stud 21
150413	Arm, Right Follower 17	150654	Guide 5,12,13	150803	Spring, Flat 6
150414	Bushing 7	150656	Handwheel 9,52	150804	Guide, Right Paper 6
150419	Shaft 7	150658	Gear, 21T 9,52	150805	Shim, .012" Thk 21
150420	Lever, Right 17	150666	Gear, 28T 9	150806	Plate 21
150423	Stud, Pivot 7	150668	Collar, Spacing 20	150807	Oiler, Felt 21
150425	Lever, Lock 17,18	150669	Shim, .002" Thk 20	150809	Gear, 32T 9
150428	Lever, Left 18	150670	Shim, .004" Thk 20	150811	Stud 17
150429	Stud, Eccentric 17,18	150672	Bearing 20	150815	Bushing 6,49
150431	Lever, Trip 10,50	150673	Shaft 20	150816	Lever 6
				150821	Spacer, .156" Thk 34
				150824	Track 17,18

## NUMERICAL INDEX (Continued)

Part Number	Description and Page Number	Part Number	Description and Page Number	Part Number	Description and Page Number
150826	Guide, Left Paper 6	151354	Screw, 2-56 x 15/32 Fil 53,58	151685	Screw, 4-40 x 5/16 Fil 7,9,10,16,17,19,24
150827	Drum, Spring 24	151442	Screw, 6-40 x 1/2 Hex 18, 26,29,32	151686	Screw, 4-40 x 3/8 Fil 6,20,27,28,49
150830	Bushing, Shoulder 16,66	151443	Eccentric 35	151687	Screw, 4-40 x 7/16 Fil 41
150851	Ring, Retaining 16,66	151572	Lockwasher 20	151688	Screw, 4-40 x 5/8 Fil 14, 16,27,61
150833	Platen Assembly 9	151602	Plate 17,18,65	151689	Screw, 4-40 x 3/4 Fil 6,15,39,55
150838	Ring, Retaining 24	151603	Spacer 17,27	151690	Screw, 10-32 x 5/16 Fil 16
150840	Bracket, Guide 6	151604	Block, Guide 17,18,65	151692	Screw, 6-40 x 3/16 Fil 4,5,6,10,11,19,20,22,34, 35,38,52,62
150841	Bearing 16,66	151606	Screw, 10-32 x 1/4 Hex 23	151693	Screw, 6-40 x 9/16 Fil 16,33
150843	Plate, Hok 24	151610	Washer, Flat 16,31,32,35,60	151695	Screw, 6-40 x 5/8 Fil 35
150891	Block 17	151611	Bushing 35	151700	Screw, 6-40 Shoulder 23
150895	Arm, Trip 10	151612	Spacer 35	151701	Spring, Torsion 25
150900	Bail, Detent 5,54	151618	Screw, 6-40 x 7/16 Fil 13,24,37	151702	Nut, 4-40 Hex 38
150903	Block, Left Paper Spindle 7,49	151619	Bushing 24	151703	Pin 6
150904	Block, Right Paper Spindle 7	151625	Strip 22	151709	Arm 35
150907	Spindle, Paper 7	151627	Rod 7	151713	Spring, Torsion 5
150909	Screw, 6-40 Shoulder 21	151629	Nut, 6-40 Lug 8,10,29,38, 51,57	151714	Spring 25
150910	Latch, Right 7	151630	Screw, 6-40 x 1/4 Hex 8,11,15,16,17,19,21,23, 25,26,28,29,30,34,35,36, 37,41,47,48,52,56,61,64, 67	151721	Screw, 6-40 x 3/4 Hex 7, 26,29,38,64
150911	Bushing, Shoulder 9,52	151631	Screw, 6-40 x 5/16 Hex 5,8,13,14,24,27,30,47, 48,58,59,65	151722	Screw, 6-40 x 3/16 Hex 3, 10,12,14,21,26,27,36,52, 55,59,64
150912	Screw, 6-40 Shoulder 9,52	151632	Screw, 6-40 x 3/8 Hex 16, 17,18,21,29,36,65	151723	Screw, 10-32 x 3/8 Hex 20,36
150923	Washer, Felt 10,35,37	151637	Screw, 4-40 x 1/4 Fil 4, 5,7,12,18,19,24,33,34,38, 47,48,50,55	151731	Screw, 4-40 x 7/8 Fil 9,14,52
150926	Washer, Felt 11,21	151638	Washer, Spring 13	151733	Screw, 4-40 x 9/16 Fil 14
150927	Oiler, Felt 22	151642	Screw, 6-40 x 3/4 Fil 15, 16	151734	Screw, 4-40 x 3/8 Hex 17
150929	Oiler, Felt 22	151657	Screw, 6-40 x 1/4 Fil 4,5,6,7,8,11,12,17,18,19, 21,25,26,29,30,33,34,37, 38,48,50,52,56,58,62	151736	Spring 16,66
150930	Washer, Felt 11	151658	Screw, 6-40 x 5/16 Fil 3, 4,7,8,9,11,13,17,18,20, 22,24,25,26,29,30,32,33, 36,41,47,51,56,66	151737	Screw, 4-40 x 11/64 Hex 15
150932	Bushing, Shoulder 33,34, 47,48	151659	Screw, 6-40 x 1/2 Fil 5,12,33,37,50,59	151738	Screw, Identification 43
150935	Latch 7	151660	Screw, 6-40 x 7/8 Fil 8	151739	Screw, Identification 38
150937	Lever 33	151661	Screw, 6-40 x 1 Fil 20	151794	Washer, Spring 16
150961	Bushing, Eccentric 5,54	151668	Roller 29	151799	Modification Kit 7
150969	Spring, Torsion 5	151676	Shim, .010" Thk 31	151880	Nut, 4-40 Hex 12,17,19, 28,41,59,65
150970	Bearing, Ball 16,52,66			152089	Latch 40
150975	Cup, Dashpot 19			152121	Lever, Function 40
150978	Screw, 6-40 x 1-1/8 Fil 27,29,30			152127	Clip 38
150987	Spacer, .090" Thk 19				
150990	Washer, Felt 7,20,29				
150992	Stud 6				
150998	Spacer, .020" Thk 9				
151073	Screw, 4-40 x 5/32 Fil 4,5,27,62				
151152	Screw, 4-40 x 3/16 Hex 12, 13,15,16,22,25,26,29,35,37, 47,48,50,58,59,60,61,64,67				
151222	Washer, Felt 15,29,38				
151336	Oiler 25				
151346	Screw, 6-40 x 3/8 Fil 7, 8,9,11,16,19,20,24,32,34, 36,45,47,50,51,55,57,62				

## NUMERICAL INDEX (Continued)

Part Number	Description and Page Number	Part Number	Description and Page Number	Part Number	Description and Page Number
152129	Spring 35	152523	Spring, Washer 33,34,47, 48	152660	Plate, Spring 40
152140	Bail 11	152524	Bracket 33,34,47,48	152704	Bar, Function 42
152147	Bearing, Ball 17	152525	Hub 33,34,47,48	152708	Lever, Keyboard Lock 62
152255	Bar w/Retainer 37	152526	Plate Right 34,47	152723	Spring 6
152257	Spring 13,37	152527	Plate, Left 33,48	152725	Spring 6
152298	Lever, Function 40	152528	Ratchet, Left Ribbon 33, 48	152726	Bushing 10
152299	Lever, Function 40	152529	Ratchet, Right Ribbon 34, 47	152818	Lever, Left Detent 33,48
152340	Modification Kit 2,49	152536	Bail 23	152819	Lever, Right Detent 34,47
152350	Modification Kit 2,62	152537	Clamp 16,52	152820	Lever, Left Feed 33,48
152357	Stud 40	152539	Guide 6	152821	Lever, Right Feed 34
152400	Plate, Selector Mounting 17,25,29	152545	Lever 11	152823	Bracket, Left 33,41
152406	Bracket, Spring 25	152547	Shaft 38	152824	Bracket, Right 34
152407	Lever, Spacing Lock 25	152548	Bar, Shift 37	152826	Pin, Detent 33,34,47,48
152409	Lever, Selecting 25	152550	Clamp 18	152827	Bracket, Left Spool 18,33
152411	Lever, Punch 25	152563	Bracket 11,36	152828	Bracket, Right Spool 17, 34
152412	Link 25	152571	Spacer, .250" Thk 33	152831	Clip 4,5
152415	Stud, Adjusting 27	152573	Retainer 15	152832	Shaft 6,49
152420	Lamination, Magnet 27	152574	Plate 37	152834	Spring, Torsion 33,34,47, 48
152421	Bracket, Shield Mounting 27	152575	Bracket 37	152871	Spring 9,66
152423	Bracket, Armature Stop Mounting 27	152576	Bracket 37,61	152875	Spacer, .050" Thk 41
152425	Post, Spring 27,58	152579	Track 21	152887	Screw, 4-40 x 1/2 Hex 15, 16
152426	Nut, 6-40 Self-Locking 27	152582	Shaft 33	152889	Plate, Retaining 38
152427	Latch w/Hub 25,26	152583	Bearing, Sleeve 29,30	152890	Washer, Flat 19
152429	Rack, Sector 25	152586	Bracket 20,62	152891	Spring 25
152438	Bail, Stop Arm 25,26,64	152589	Clamp 18	152893	Screw, 4-40 x 1/4 Hex 8, 11,14,18,24,25,41,47,48
152441	Washer, Flat 25,26	152592	Guide 21,22	152927	Bushing 12,46,50
152445	Spring, Compression 25	152595	Slide 22	152938	Spacer, .125" Thk 12,50, 59
152456	Holder, Wick 17,29,30	152603	Carriage Assembly 17	152943	Screw, 10-32 Spl 12,50
152457	Wick, Felt 29,30	152606	Rail Assembly, Oscillating 21	153172	Spring 21
152458	Shield, Terminal 27	152614	Track Assembly 21	153173	Plate, Clamp 21
152461	Bracket 3	152629	Washer, Friction 33,34, 47,48	153174	Link, Left 21,22
152462	Latch, Right 3	152634	Washer, Flat 19,20,49,61	153175	Link, Right 21,22
152463	Latch, Left 3	152637	Lever, No.3 Transfer 29	153184	Post 27
152464	Insulator, .062" Thk 3,27	152641	Lever, Function 40	153185	Gear, 30T 12,13,50
152467	Connector, 20 Pt Plug 3	152642	Lever, Function 40	153189	Spring, Compression 12, 46,50
152505	Stud 22	152644	Bracket 33	153191	Pointer 12,50
152507	Roller, Detent 22	152646	Lever, Left Reversing 33	153192	Spring, Torsion 12,13,50
152508	Bracket, Right 22	152647	Lever, Right Reversing 34,47	153196	Handwheel 12,46,50
152509	Bracket, Left 22	152648	Stud 34	153198	Gear, 48T 46
152510	Lever, Detent 22	152651	Plate, Guide 38,61	153199	Gear, 51T 46
152511	Guide 21,22	152652	Bar, Guide 38	153200	Gear, 54T 46
152514	Bail 11	152653	Pawl, Function 40	153201	Gear, 57T 46
152515	Lever, Space Trip 11	152659	Lever, Function 40	153202	Gear, 60T 46
152516	Slide 11				
152518	Bail 11				

## NUMERICAL INDEX (Continued)

Part Number	Description and Page Number	Part Number	Description and Page Number	Part Number	Description and Page Number
153203	Gear, 66T 12,46,50	153322	Guide 38,61	153670	Lever, Function 40
153204	Gear, 72T 46	153323	Ring, Spacer 15	153676	Bail, Detent 5
153205	Gear, 78T 46	153335	Plate 22	153678	Bracket w/Shaft 8,57,58
153206	Gear, 84T 46	153337	Bushing 22	153682	Bracket, Right 8
153207	Gear, 90T 46	153340	Spring, Left Torsion 22	153683	Bracket, Left 8,45,57
153229	Bushing, Shoulder 52	153341	Spring, Right Torsion 22	153685	Arm w/Hub 8
153230	Bar, Line Feed 52	153360	Stud 36	153686	Bearing, Right 8,57
153231	Bar, Line Feed 52	153361	Post 36	153687	Bearing, Left 8,57
153233	Guide 52	153365	Arm, Cam 36	153689	Gear, 33T 8,57
153235	Plate 16,66	153367	Arm 10,36	153690	Gear, 28T 8
153236	Gear, 42T 16,66	153368	Bail, Follower 10	153692	Gear, 33T 8,57
153237	Arm 52	153375	Arm, Slide 36	153695	Pin 8
153239	Roller 52	153382	Bail, Transfer 11	153696	Spring 8
153240	Retainer, Bearing 52	153383	Arm, Bail Extension 11	153697	Bracket 8
153241	Link 52	153440	Bar, Function 42	153698	Cam, Feed 8,57
153242	Bracket 52	153442	Screw, 10-32 x 1/2 Hex 7,14	153699	Cam, Feed 8,57
153254	Bracket 62	153489	Detent 25	153791	Shaft 8
153255	Bail 11	153530	Plate 17	153794	Plate, Adjusting 8,45,57, 60
153256	Bracket 19,62	153531	Plate, Adjusting 17	153799	Screw, 4-40 x 21/64 Hex 8,16
153257	Bail 62	153532	Screw, 4-40 Adjusting 17	153806	Spring 10
153258	Bushing 62	153537	Screw, 6-40 x 9/32 Hex 53	153810	Guide, Ribbon 17
153259	Arm 62	153538	Screw, 6-40 x 7/16 Hex 5,26,32,47,64	153815	Clutch Assembly, Function 15
153260	Plate 62	153550	Link 7	153817	Screw, 4-40 x 3/8 Hex 19, 21
153261	Bushing, Threaded 62	153553	Roller 7	153819	Lockwasher 27,37
153262	Arm 62	153558	Link 7	153820	Frame, Printing Carriage 35
153263	Arm, Stop 62	153569	Arm, Trip 10,65	153823	Collar 15
153267	Washer, Felt 26,52,64	153570	Arm, Suppression 65	153824	Clamp 15
153287	Spring 52	153573	Bail 7	153830	Guide, Rear 51
153288	Spring 62	153575	Wick, Felt 11	153833	Bracket, Guide 51
153291	Arm 15,38	153576	Cam, Function 15	153838	Shaft 38
153292	Plate 15	153577	Washer, Felt 7	153839	Screw, 6-40 x 5/8 Hex 7,8,10,17,38,51,64
153293	Spacer, Clutch 15	153581	Handle 38	153841	Screw, 6-40 x 9/16 Hex 23
153294	Cam 38,55	153582	Screw, 6-40 Shoulder 11	153926	Modification Kit 51
153295	Shaft 38	153583	Lever, Trip 10	154051	Screw, 6-40 Shoulder 12, 50
153296	Eccentric 15	153584	Lever, Latch 10	154127	Nut, 6-40 Hex 54
153298	Bracket, Right 5,38	153586	Guide 5	154290	Ring, "O" 8,45,57
153299	Bracket, Left 38	153587	Guide 4	154310	Spring 24
153300	Arm 15	153598	Pawl, Function 40	154320	Finger, Left Paper 8
153301	Arm 38,55,63,66	153600	Bracket, Spring 35,37	154323	Cam, Eccentric 20
153302	Blade, Stripper 38	153601	Bushing, Shoulder 61	154332	Shaft 33,34
153303	Slide, Stripper 38	153604	Pawl, Function 40	154333	Roller 33,34
153304	Bushing, Shoulder 32	153610	Spindle 49	154349	Spring 25
153305	Spring, Torsion 11	153611	Disc, Paper Spindle 49	154354	Slide 17,21
153310	Bail 11	153615	Lever 49		
153311	Arm 11	153631	Network, Spark Suppression 28,41,47,48		
153312	Lever 32	153634	Collar 6,49		
153314	Bracket 11,62				
153318	Shaft 38				
153321	Bracket, Tie 37				

## NUMERICAL INDEX (Continued)

Part Number	Description and Page Number	Part Number	Description and Page Number	Part Number	Description and Page Number
154356	Bail 17	155072	Shaft 38	155873	Pallet, Type 43
154358	Hub, Platen 8,45,57	155073	Shaft 38	155896	Finger, Left Paper 8,51
154362	Spring, Contact 14,36,55	155074	Shaft 38	155897	Finger, Right Paper 8,51
154380	Bracket w/Post 37	155075	Shaft 38	155954	Switch, Sensitive 31, 53
154389	Cam, Eccentric 20	155076	Shaft 38	156093	Washer, Felt 9,66
154516	Ratchet 24	155077	Shaft 38	156450	Screw, 2-56 x 1/2 Fil 31,32,67
154519	Lever, Latch 8	155096	Plate, Range Finder Mounting 25,26	156501	Screw, 6-40 x 7/32 Fil 5
154613	Latch 40	155099	Screw, 6-40 Shoulder 38,63,66	156521	Screw, 6-40 Eccentric Shoulder 28
154614	Cam, Spacing 16	155432		156536	Screw, 4-40 x 1/8 Fil 25
154623	Ring, Retaining 24	thru		156558	Washer, Felt 47,48
154624	Ring w/Roller 24	155445	Pallet, Type 44	156572	Washer, Felt 35
154626	Ring 24	155446	Pallet, Type 43,44	156574	Post, Spring 26,38
154627	Drum, Spacing 24	155447		156632	Screw, 6-40 x 13/32 Hex 24
154638	Spring 35	thru		156740	Screw, 6-40 x 7/32 Hex 5,28,30,37,45,60,65
154645	Spacer 7	155467	Pallet, Type 44	156880	Jumper, 2-3/8" Black 27
154646	Lever, Function 40	155469	Pallet, Type 44	156881	Jumper, 1-1/2" Black 27
154647	Lever, Function 40	155670	Pallet, Type 44	156971	Screw, 2-56 x 3/4 Fil 32,56,58
154649	Arm 11,62	155473	Pallet, Type 44	157194	Retainer, Spring 27
154650	Clip 37	155479	Pallet, Type 44	157203	Stud, Shoulder 40
154666	Shaft 38	155480	Pallet, Type 44	157205	Lever, Function 40
154667	Shaft 38	155483	Pallet, Type 44	157206	Lever, Function 40
154668	Shaft 38	155565	Arm, Right 8,51	157207	Lever, Function 40
154669	Shaft 38	155566	Arm, Left 8,51	157237	Shield, Terminal 27
154670	Screw, 6-40 Spl 24	155587	Link w/Stud 29	157238	Spring 43
154671	Bracket 24	155589	Plate w/Stud 29	157240	Spring 40
154688	Spring 7	155618		157241	Bracket, Roller 7
154691	Clip 38	thru		157245	Post 61
154692	Clip 38	155658	Pallet, Type 44	157261	Shaft, Stop Arm 25
154694	Disc, Clutch Cam 15,16,64	155667		157274	Clip 38
154698	Wick, Felt 36	thru		157275	Clip, Spring 38
154760	Modification Kit 46	155673	Pallet, Type 44	157286	Clamp, Platen 8
154761	Modification Kit 46	155713	Clip 40	157289	Crossbar 6,51
154762	Modification Kit 46	155714	Bracket 36	157290	Bail, Pressure 6
154763	Modification Kit 46	155715	Stud 36	157291	Guide, Rear Paper 6
154764	Modification Kit 46	155736	Lever, Function 40	157505	Clutch Assembly, Spacing 16
154765	Modification Kit 46	155737	Lever, Function 40	157506	Clutch Assembly, Line Feed 16
154766	Modification Kit 46	155738	Bail, Blocking 40	157510	Modification Kit 2,62
154767	Modification Kit 46	155750	Sleeve, 3/32 ID x 1/2" Lg Insulating 28,32,53,60	157511	Modification Kit 2,52
154768	Modification Kit 46	155751	Sleeve, 1/8 ID x 1" Lg Insulating 27,31,32,48	157514	Modification Kit 20
154769	Modification Kit 46	155753	Sleeve, 1/8 ID x 1/2" Lg Insulating 28,32,36,37	157600	
154771	Modification Kit 2,50	thru		thru	
154792	Modification Kit 20,24	155796	Shaft 29	157635	Pallet, Type 43
154798	Modification Kit 2,51	155864	Shaft, Cam 7		
154872	Bracket 4	155865	Stud 7		
155044	Spacer 15	155871	Pallet, Type 43,44		
155047	Disc 15				
155060	Slide, Stripper 38				
155061	Blade, Stripper 38				
155071	Shaft 38				

## NUMERICAL INDEX (Continued)

Part Number	Description and Page Number	Part Number	Description and Page Number	Part Number	Description and Page Number
157636		158344	Nut, 6-40 Shoulder 36	160511	Disc, Retaining 46
thru		158346	Lever w/Hub 36	160512	Disc, Retaining 46
157649	Pallet, Type 43,44	158347	Bracket 36	160513	Disc, Retaining 13,46
157658	Pallet, Type 43,44	158348	Bracket 20	160514	Disc, Retaining 46
157659	Pallet, Type 43,44	158349	Arm, Slide 36	160523	Plate, Mounting 14
157660	Pallet, Type 43,44	158351	Pawl w/Stud 36	160527	Spring 46
157662	Pallet, Type 43,44	158352	Bail, Trip 10	160528	Spring 46
157663	Pallet, Type 43	158353	Bail, Stop 10	160529	Spring 46
157664	Pallet, Type 43,44	158354	Arm, Extension 10	160530	Spring 46
157665	Pallet, Type 43	158357	Wheel, Horizontal Tab 24	160531	Spring 46
157666	Pallet, Type 43,44	158365	Blade, Reset 7	160532	Spring 12,46
157671	Pallet, Type 43,44	158485	Bracket, Left 51	160533	Spring 46
157678	Pallet, Type 43,44	158486	Bracket, Right 51	160534	Spring 46
157717	Pallet, Type 44	158487	Shaft 51	160535	Spring 13,46
157720	Pallet, Type 44	158816	Spring, Contact 41	160536	Spring 46
157721	Pallet, Type 43	159181	Lubricator 25	160568	Contact Assembly 14
157726	Pallet, Type 43,44	159184	Wick, Lubricating 25	160569	Bracket 14,31
157729		159185	Retainer, Wick 25	160572	Slide, Stripper 38
thru		159334	Washer, Insulating 11	160573	Blade, Stripper 38
157763	Pallet, Type 44	159341	Bearing, Ball 15,18	160574	Arm w/Stud 12,13,50
157765	Pallet, Type 43,44	159752		160576	Slide, Stripper 38,66
157766		thru		160577	Blade, Stripper 38,66
thru		159786	Pallet, Type 44	160578	Sleeve, Pinion 12,46,50
157779	Pallet, Type 44	159788	Pallet, Type 44	160583	Spring, Contact 41
157790	Pallet, Type 43,44	160087	Post, Spring 67	160626	Insulator, .031" Thk 14
157791	Pallet, Type 43,44	160180	Armature w/Extension 27	160630	Spring, Contact 14
157804	Pallet, Type 43,44	160182	Bracket w/Button 27	160631	Spring, Contact 14
157816	Pallet, Type 44	160184	Plate, Stop 27	160779	Pallet, Type 44
157820	Pallet, Type 44	160185	Post 27	160843	Spring 10
157887	Arm, NO Contact 39	160186	Bushing, Shoulder 27	160937	Bail 5
157899	Arm, NC Contact 39	160187	Shield, Oil 27	160939	Post, Spring 5
157972	Bellcrank 20,61	160486	Bail 12,13,50	160940	Post 5
157973	Extension, Transfer 20, 61	160489	Plate, Form Stop 46	160944	Washer, Felt 22
157979	Link, Toggle 33	160490	Pawl 12,50	161250	Gear, 88T 46
157991	Stud 7,11	160491	Plate w/Stud 12,13,50	161346	Washer, Felt 33,34,47,48
158186	Screw, 4-40 x 7/32 Fil 31	160493	Plate, Adjusting 12,50	161347	Washer, Felt 7,20,22,23
158317	Insulator, Switch 8,31, 53,58,67	160495	Plate w/Stud 12,50	161366	Pallet, Type 44
158318	Cable 53	160498	Plate, Mounting 50	161369	Pallet, Type 44
158334	Spring, Tension 24	160499	Lever, Blocking 50	161649	Lever, Function 40
158335	Stud 19,36	160500	Lever, Blocking 12,13, 50,59	162059	Lever, Function 40
158337	Plate w/Pin 19	160502	Slide, Form-Out 50	162484	Lever, Function 40
158339	Arm w/Pin 36	160503	Slide, Tab 11,50	162573	Retainer 16,66
158340	Bracket, Stop 24	160505	Disc, Retaining 46	162728	Arm 11
158341	Plate, Stop 12,13,24,46	160506	Disc, Retaining 46	162729	Bar, Guide 11,12,36,50,62
158342	Arm 24	160507	Disc, Retaining 46	162881	Plate 36
158343	Bracket, Spring 24	160508	Disc, Retaining 46	162882	Bushing, Insulating 14
		160509	Disc, Retaining 46	163146	Modification Kit 2,55
		160510	Disc, Retaining 12,46,50	163147	Contact Assembly 55
				163148	Shaft 55
				163150	Collar 55

## NUMERICAL INDEX (Continued)

Part Number	Description and Page Number	Part Number	Description and Page Number	Part Number	Description and Page Number
163152	Cam w/Stud 55	170004	Bracket w/Bushing 7,10, 11,25	170236	Lever 25
163153	Cam, Trip 55	170023	Bearing 29,30	170237	Lever, Start 25
163157	Cam, Drive 55	170024	Bracket 29	170238	Bail, Reset 25
163158	Bracket w/Hub 55	170025	Bracket w/Stud 29	170282	Nut, 6-40 Hex 58
163159	Lever 55	170026	Bellcrank w/Bushing 29	172500	thru
163181	Wheel, Horizontal Tab 24	170027	Bellcrank 29	172590	Switch Assembly 39
163182	Bracket, Stop 24	170028	Link 29	172591	Spring, Contact Arm 39
163183	Modification Kit 2,65	170039	Bellcrank w/Posts 19,20	172593	Plate, Contact 39
163184	Bracket, Magnet 65	170042	Bail w/Bushing 11	172594	Plate, Contact 39
163185	Armature 65	170054	Arm w/Post 19,22	172595	Plate, Contact 39
163197	Pallet, Type 43,44	170056	Plate w/Stud 19,20,21,22, 23,24,36,61,62	172596	Plate, Contact 39
163198	Pallet, Type 43,44	170057	Bearing 20	172597	Block, Contact 39
163250	Pin 65	170058	Nut, 10-32 Shoulder 20	172599	Block, Contact 39
163254	Magnet Assembly 65	170059	Pawl, Drive 20	172600	thru
163271	Lever, Function 40	170060	Plate, Guide 19,20	172608	Switch Assembly 39
163308	Pallet, Type 44	170062	Bail 19	172618	Plate, Contact 39
163309	Pallet, Type 44	170063	Lever 20	172619	Plate, Contact 39
163311	Pallet, Type 44	170064	Link, Drive 19,20	172632	Screw, 4-40 x 3/16 Hex 15,64
163313	Pallet, Type 44	170067	Washer, Spacing 15	173141	Lever, Function 40
163314	Pallet, Type 44	170071	Clutch Assembly, Codebar 15	173259	Link 35
163535	Modification Kit 14	170074	Arm 11	173260	Carriage Assembly 2,35
163590	Gear, 60T 16	170075	Roller 11	173284	Lever, Lock 23
163943	Lever w/Pin, Function 40	170076	Pawl 11	173715	Terminal, Plug Type 27,28,31,32,36,48,53,58, 60,64
163944	Lever, Function 40	170079	Arm w/Hub 23	173716	Terminal, Receptacle Type 67
163948	Gear, 28T 54	170080	Stud 20,24	173882	Stud 65
163949	Bushing 54	170111	Shaft 15,16	173883	Bracket, Mounting 65
163957	Lever 54	170112	Guide 29,30	173902	Spring, Compression 37
163958	Washer, Flat 54	170113	Arm 29	173940	Terminal, Plug Type 32, 48,58
163959	Spring, Torsion 5,54	170115	Lever, No.7 Transfer 29	173941	Terminal, Receptacle Type 48
163960	Bushing 54	170117	Bracket 29,30	174439	Modification Kit 64
164300	Spacer, .100" Thk 26,64	170118	Bracket 17,29	174441	Lever w/Bushing 26,64
164311	Lever, Function 40	170119	Lever 29,30	174442	Contact Assembly 26,64
164313	Bracket 35	170120	Lever 29,30	174444	Spring, Contact 26,64
164316	Plate, Clamp 21	170121	Shaft 29,30	174445	Bracket, Contact Mounting 26,64
164386	Bracket, Magnet Mounting 26,27,64	170122	Lever 29	174446	Spring, Contact 26,64
164478	Contact Assembly 36	170123	Bracket, Retaining 29	174447	Post 26,64
164740	Rack, Range Finder 26,64	170124	Lubricator Assembly 25	174448	Guard 26,64
164743	Shaft 26,64	170125	Lever, Shoe Release 15	174449	Bracket 26,64
164958	Screw, 4-40 x 1/2 Hex 65	170198	Arm, Stop 25,26	174450	Cam 15,64
164960	Insulator, .015" Thk 65	170199	Bracket, Anchor 14	174451	Cam 64
165027	Network, Spark Suppression 47,48	170230	Knob 25		
165217	Jumper, 1-1/2" Green 58	170231	Guide, Upper 25		
165914	Stud 40	170232	Guide, Lower 25		
170000	Frame, Right Side 4,6 to 11,17,25,27,29,33,34,51, 56,57,58	170233	Stud 25,26		
170001	Housing, Bearing 17	170234	Bracket, Guide 25		
		170235	Bracket, Spring 25		

## NUMERICAL INDEX (Continued)

Part Number	Description and Page Number	Part Number	Description and Page Number	Part Number	Description and Page Number
174452	Spacer, .085" Thk 26,64	179224	Slide Assembly 22	192302	Pawl Assembly 9
174482	Lever 40	179225	Bail w/Studs 22,23	192304	Blade, Bail 38
174483	Lever 40	179226	Screw, 4-40 Shoulder 22	192305	Bail 11
174484	Lever 40	179396	Plate, Front Type Box 43	192307	Slide 38
174570	Switch 56,58	179397	Plate, Rear Type Box 43	192308	Bail, Stripper 38
176221	Platen, 8-1/8 Rubber 45	179451	Plate, Right 22	192309	Pin 38
176222	Platen, 7-5/8 Rubber 45	179452	Plate, Left 22	192310	Spring, Torsion 38
176223	Platen, 7-1/8 Rubber 45	179675	Bracket 48	192311	Arm 38
176224	Platen, 6-5/8 Rubber 45	179676	Lever, Left Guide 48	192312	Shaft 9
176225	Platen, 6-1/8 Rubber 45	179677	Shaft, Ribbon Spool 47,48	192313	Bracket, Left 4,38,55,63, 66
176226	Platen, 5-5/8 Rubber 45	179678	Lever 47,48	192314	Handle 38
176227	Platen, 5-1/2 Rubber 45	179680	Bail, Left Lifter 48	192317	Lever 28
176228	Platen, 5-3/8 Rubber 45	179681	Post 47,48	192318	Jumper, 2-3/4" Black 27
176229	Platen, 5-1/8 Rubber 45	179682	Bail, Left Roller 48	192321	Stud 19
176230	Platen, 4-7/8 Rubber 45	179684	Lever 47,48	192322	Spring, Compression 19
176231	Platen, 4-5/8 Rubber 45	179686	Bracket, Right 47	192323	Spring 22
176232	Platen, 4-1/8 Rubber 45	179687	Lever, Right Guide 47	192329	Plate w/Stud 36
176233	Platen, 3-5/8 Rubber 45	179689	Bracket, Left 48,59	192332	Bracket w/Stud 36
176234	Platen, 3-7/16 Rubber 45	179690	Plate 48	192333	Lever w/Bushing 36
176235	Platen, 3-3/8 Rubber 45	179691	Bracket, Left 48	192337	Spacer, .243" Thk 31
176236	Platen, 3-1/8 Rubber 45	179692	Spacer 47,48	192339	Plate w/Post 31
176237	Platen, 2-3/4 Rubber 45	179693	Bail, Right Lifter 47	192341	Plate 31,32
176238	Platen 8,57	179694	Bail, Right Roller 47	192342	Screw, 2056 x 1-1/16 Fil 31
176246	Bail, Blocking 40	179695	Bracket, Left Magnet 48	192343	Lever w/Hub 31
176247	Bail, Blocking 40	179696	Bracket, Left Hinge 48	192345	Spring, Torsion 31
176285	Bail, Pressure 51	179697	Lever, Left Stop 48	192347	Slide 36
176299	Screw, 6-40 Shoulder 65	179698	Armature 47,48	192348	Lever w/Hub 36
176355	Arm, Cam Follower 10	179699	Shaft 47,48	192459	thru
176356	Screw, 6-40 Pilot 11	179700	Bracket, Right Hinge 47	192480	Bar, Function 42
176420	Modification Kit 2,64	179701	Lever, Right Stop 47	192482	Alarm Assembly, Paper-Out 32
176421	Modification Kit 2,64	179702	Bracket, Right Magnet 47	192483	Cable w/Terminals 32
176477	Plate 51	179703	Bracket 47	192484	Cable w/Terminals 27
176598	Bellcrank 52	179704	Shaft, Right 47	192487	Contact Assembly 14
176609	Spring, Contact 14	179708	Plate, Adjusting 47	192488	Contact Assembly 14
176642	Clip, Spring 38	179718	Cable 48	192491	Ring Assembly, Stop 24
176909	Frame, Left Side 3	179724	Modification Kit, 2,47,48,59	192492	Cable w/Terminals 36
176910	Frame, Right Side 3	179802	Cover 55	192493	Spring 25
178607	Stud, Cam Follower 11	179814	Box Assembly, TD Type 43	192495	Solenoid Assembly 2,28
179081	Pallet, Type 43	179999	Bail, Spring 33,34,47,48	192496	Cable w/Terminals 28
179082	Pallet, Type 43	180860	Spring 10,50	192513	Codebar, No.1, No.2, and No.7 37,61
179088	Pallet, Type 43,44	181284	Spring 15,16	192514	Codebar, No.3 37,61
179089	Pallet, Type 44	182909	Spring 25	192515	Codebar, No.5, No.4 and Common 37,61
179090	Pallet, Type 44	183086	Clip 67	192516	Codebar, No.6 37,61
179091	Pallet, Type 43,44	183104	Spring 17,18		
179194	Bracket 11,12,50	192007	Terminal, Tab Type 67		
179198	Lever 52	192013	Connector, 50 Pt Plug Type 27		
179199	Lever 54	192301	Clutch Assembly, Line Feed 16		
179216	Arm, Right Slide 22				
179217	Arm, Left Slide 22				



## NUMERICAL INDEX (Continued)

Part Number	Description and Page Number	Part Number	Description and Page Number	Part Number	Description and Page Number
192518	Codebar, Suppression 37,61	192997	Bracket 48	195071	Pallet, Type 44
192540	Lever w/Hub 37	193564	Spring, Contact 55	195072	Pallet, Type 44
192541	Lever w/Hub 37	193655	Lever, Function 40	195109	Plate, Stop 38
192542	Lever w/Hub 37	193858	Frame, Left Side 5 to 16, 18,28,31,32,33,45,49,50, 52,53,54,56,57,59,60,62, 65,66	195150	Lever, Reversing 48
192544	Plate w/Bearing 37	194019	Pallet, Type 44	195200	Pallet, Type 43,44
192545	Bracket 37	194037	Pallet, Type 44	195201	Pallet, Type 43
192546	Post 37	194039	Pallet, Type 44	195202	Pallet, Type 43
192547	Arm, Suppression 10	194052	Plate, Form Stop 12,46	195203	Pallet, Type 43
192548	Bail 37	194093	Modification Kit 5	195205	Pallet, Type 44
192549	Pin 37	194144	Clutch Assembly, Spacing 16	195206	Pallet, Type 44
192560	Slide 19	194148	Stud 53	195207	Pallet, Type 44
192561	Bar w/Hub 19,22	194153	Arm 10,65	195240	Post 27
192563	Bracket w/Stud 19,22	194154	Stud 10,65	195251	Armature, Selector 27
192566	Link, Left Drive 22,23	194155	Set of Parts 8	195634	Modification Kit 27
192567	Link, Right Drive 22,23	194208	Pallet, Type 44	195712	Plate, Identification 21
192575	Link, Right 21,22	194209	Pallet, Type 44	195836	Shaft 15
192576	Lini, Left 21,22	194324	Modification Kit 2,53	195855	Pin, Sprocket Feed 8,45, 57
192580	Cam 15	194325	Bracket w/Post 53	195996	Gear, 63T 16
192581	Lever, No.1 Transfer 29	194326	Bracket, Switch 53	196917	Pallet, Type 43
192582	Lever, No. 2 Transfer 29	194327	Lever 53	196921	Pallet, Type 43
192583	Lever, C Transfer 29	194335	Pallet, Type 44	196924	Pallet, Type 43
192584	Lever, No.4 Transfer 29	194336	Pallet, Type 44	197085	Cable w/Terminal 32
192585	Lever, No.5 Transfer 29	194371	Guide 53	197088	Cable w/Terminal 36
192586	Lever, No.6 Transfer 29	194414	Lever 40	197751	Modification Kit 5
192588	Bracket 27	194868	Gear, 48T 16	197752	Bracket, Support 5
192610	Arm, Slide 5,11	194870	Gear, 16T 9	197924	Arm, Left Follower 18
192611	Plate, Mounting 12,59	194871	Disc, 6 Stop 16	197957	Gear, 34T 54
192614	Lever w/Hub 12	194872	Disc, 6 Stop 16	197958	Gear w/Shaft, 37T 54
192616	Lever 12,14,59	194873	Disc, 6 Stop Adjusting 16	197996	Roller, Front 47,48
192617	Lever, Blocking 12,14,50,59	194884	Pallet, Type 44	197997	Box Assembly, TF Type 44
192618	Plate, Contact 12,14,59	194885	Pallet, Type 44	198019	Lamp, 6V 67
192619	Post, Eccentric 12	194886	Pallet, Type 44	198218	Arm 38
192620	Bracket, Contact 14	194956	Spring 16	198416	Stud, Shoulder 40
192621	Bracket, Contact 14	194982	Clip, Connector 27	198454	Arm, Power Drive 41
192622	Bracket, Detent 37	194998	Plate, Mounting 58	198455	Link 41
192627	Follower, Bellcrank 32	194999	Cable Assembly 58	198456	Link 41
192628	Bracket w/Stud 32	195000	Lever, Operating 58	198457	Bracket 41
192635	Plate w/Stud 28	195001	Insulator, .032" Thk 56,58	198463	Bar, Function 42
192639	Clutch Assembly, Selector 15	195056	Spring 29	198464	Bar, Function 42
192640	Cam, Selector 15	195057	Guard, Contact Spring 14	198465	Bar, Function 42
192641	Plate w/Posts 28	195064	thru	198466	Bar, Function 42
192643	Lever w/Hub 28	195067	Pallet, Type 44	198467	Bar, Function 42
192646	Bushing, Eccentric 28	195069	Pallet, Type 44	198468	Bar, Function 42
192647	Slide 28	195070	Pallet, Type 44	198469	Bar, Function 42
192648	Lever 28			198470	thru
192704	Disc, Retaining 46			198473	Bar, Function 42
192706	Modification Kit 46			198483	Solenoid 41
				198492	Stud 41

## NUMERICAL INDEX (Continued)

Part Number	Description and Page Number	Part Number	Description and Page Number	Part Number	Description and Page Number
198496	Solenoid 41	305023	Lock, Shaft 8,57	307065	Modification Kit 2,54
198497	Lever w/Hub 37	305024	Arm, Right 57	307076	Gear, 30T 16
198498	Bail 37	305025	Retainer, Platen Hub 8,57	307077	Clutch Assembly, Selector 15
198500	Modification Kit 41	305026	Hub, Right Platen 8,57	307078	Cam, Selector 15
198502	Pin, Solenoid Plunger 41	305027	Arm, Right 57	307083	Spring, Contact 36
198503	Bushing, Shoulder 41	305028	Guide, Paper 57	307085	Lever 40
198506	Spring 37	305029	Hub Assembly, Platen 57	307180	Box Assembly, TN Type 44
198507	Resistor, 100 Ohm 41	305031	Gear w/Shaft 28T 54	307255	Pallet, Type 43
199224	Bar, Function 42	305033	Handwheel 54	307256	Pallet, Type 43
199225	Bar, Function 42	305034	Arm w/Hub 54	307257	Pallet, Type 43
199408	Bracket 59	305035	Modification Kit 2,54	307289	Lever 54
199410	Arm 23	305036	Modification Kit 2,9,54	307299	Retainer 38
199437	Cam 16	305037	Modification Kit 2,57	307864	Box Assembly, TX Type 43
199438	Hub 16	305058	Guide, Form 57	309690	Bumper, Rubber 5
199439	Bearing 16	305080	Alarm Assembly, Low Paper 31	309692	Bracket w/Post 5,12,13
199440	Screw, 6-40 x 5/8 Fil 15,16	305082	Box Assembly, TK Type 43	310309	Box Assembly, TR Type 44
199457		305090	Box Assembly, TP Type 44	310657	
thru		305130	Bracket 52	thru	
199463	Pallet, Type 44	305465	Contact Assembly 14	310666	Pallet, Type 44
199773	Pallet, Type 43	305473	Bail 14	311071	Box Assembly, TS Type 43
199974	Box Assembly, TH Type 44	305474	Bracket 14	311407	Box Assembly, TV Type 43
199986	Box Assembly, TJ Type 44	305539	Modification Kit 2,63	311412	Post, Eccentric 26
199987	Pallet, Type 43,44	305540	Modification Kit 2,63	311413	Post, Eccentric Guide 30
199989	Pallet, Type 44	305541	Slide, Stripper 63	311414	Post, Spring 30
199990	Pallet, Type 44	305551		311415	Bracket, Stop 30
301761		thru		311416	Lever, Latch 30
thru		305556	Pallet, Type 43	311417	Arm 30
301764	Bar, Function 42	305558		311418	Arm 30
304395	Spring 22	thru		311419	Cover, Insulating 36
304396	Plate, Stop 54	305568	Pallet, Type 43	311420	Lever, Reset 26
304460	Spring 63	305584	Pallet, Type 44	311422	Bracket, Guide 30
304461	Bushing 63	305589	Pallet, Type 43,44	311423	Plate 26,27
304463	Slide, Stripper 63	305590	Pallet, Type 44	311424	Lever 30
304464	Blade w/Stud 63	305677	Cable w/Terminals 32,53	311425	Bail, Reset 30
304465	Blade, Stripper 63	305771	Bracket, Guide 51	311426	Bracket 30
304740	Head, Print Hammer 35	306098	Wire, Guide 58	311456	Modification Kit 2,58
304769	Plate w/Post 31	306646	Contact Assembly 36	311457	Bracket, Bail 58
304771	Lever w/Hub 31	306648	Spring, Contact 36	311458	Modification Kit 2,60
304772	Guide, Paper 45	306670		311459	Modification 2,60
304773	Guide, Paper 45	thru		311460	Modification Kit 2,60
304774	Guide, Paper 45	306685	Guide, Form 45	311461	Modification Kit 2,60
304775	Guide, Paper 45	306686		311462	Bracket 60
304776	Alarm Assembly 31	thru		311464	Slide 60
304778	Bail w/Wire 58	306702	Modification Kit 45	311465	Lever 60
304779	Bail w/Wire, 8-1/2" Wide 58	306704	Bar, Function 42	311466	Tray, Paper 60
		306705	Bar, Function 42	311467	Tray, Paper 60
304833	Box Assembly, TM Type 43	306706	Bar, Function 42	311468	Tray, Paper 60
305022	Shaft 8,57	306979	Box Assembly, TL Type 43	311469	Tray, Paper 60

## NUMERICAL INDEX (Continued)

Part Number	Description and Page Number	Part Number	Description and Page Number	Part Number	Description and Page Number
311471	Bracket, Left 60	323592	Contact Assembly 37	328979	Link 13
311730	Cable Assembly 60	323593	Lever w/Hub 37	328980	Link w/Post 13
312395	Bracket 41	323594	Lever w/Hub 37	328982	Lever 13
312552	Cable w/Terminals 32	323595	Plate, Contact 37	328983	Bracket 8
312571	Lever w/Hub 37	323599	Cover, Insulating 37	328984	Gear, 20T 13
312711	Modification Kit 2,59	323600	Box Assembly, DF Type 43	328985	Plate 13
312755	Post, Eccentric 59	323655	Cable w/Terminals 48	328986	Stop 13
312756	Bracket, Contact 59	324081	Lever 29	328987	Plate 8
312757	Plate 59	324095	Modification Kit 2,58	328988	Switch 8,67
312980	Bail, Right 58	324098	Bail 58	328989	Spacer 13
312981	Bail, Left 58	324465	Box Assembly, DG Type 44	328990	Bracket 8
315532	Bar, Function 42	324489	Plate 56	328991	Plate 13
315533	Bar, Function 42	324490	Modification Kit 2,56	328992	Plate 13
317218	Bar, Function 42	324491	Lever 56	328993	Plate, Switch 13
317353	Box Assembly, TY Type 43	324492	Bail 56	328994	Bushing 13
319936	Screw, 4-40 Shoulder 41	324494	Lever 56	328995	Lever, Shift 13
319937	Bracket 41	324495	Cable Assembly 56	328996	Plate 13
320408	Terminal, Spade Type 27	325936	Bushing, Insulating 14	328997	Plate w/Stud 13
320410	Terminal, Spade Type 27,53	325966	Insulator 14	328998	Lever, Blocking 13
320443	Lever w/Hub 37	325967	Modification Kit 2,66	328999	Chute, Paper 67
321095	Bracket, Tie 61	326007	Plate, Clamp 8	329002	Lever 54
321096	Bracket 61	326478	Spring, Torsion 58	329003	Sprocket, 20T 54
321097	Lever 61	326712	Spring, Torsion 56	329004	Sprocket, 10T 54
321098	Bar w/Post 61	326799	Spring, Torsion 60	329005	Arm 54
321099	Modification Kit 2,61	328110	Spring, Contact 36	329006	Shaft 54
321574	Bracket 31	328939	Screw, 6-40 Shoulder 8	329008	Gear w/Shaft 54
321681		328940	Lever 8	329010	Handwheel 54
thru		328942	Arm, Left 8	329011	Belt, 27T 54
321692	Pallet, Type 44	328943	Arm, Right 8	329012	Guide, Form 45
321694		328946	Lever w/Hub, Left 67	329013	Handwheel Assembly 2,54
thru		328947	Lever w/Shaft, Right 67	329014	Chute Assembly, Paper 2,67
321700	Pallet, Type 44	328950	Deflector, Paper 8	329015	Disc Assembly 13
321702	Pallet, Type 44	328951	Post 8	329016	Disc Assembly 13
321703	Pallet, Type 44	328953	Lens w/Plate 67	329017	Cable Assembly 8,67
321705	Box Assembly, DB Type 44	328954	Lever, Control 67	329019	Cable Assembly 67
321780	Pallet, Type 44	328955	Cam, Left 8	329020	Plate 8
321782	Cover, Contact 41	328956	Cam, Right 8	329021	Lever 31
321935	Arm, Left 8	328957	Plate, Front 67	329023	Pawl 13
321983	Box Assembly, DC Type 43	328958	Arm, Right 8	329024	Cable w/Terminals 67
323026	Cable w/Terminal 64	328959	Stop, Paper 67	329026	Label 67
323040	Cable w/Terminals 31	328960	Guide, Paper 8	330681	Modification Kit 51
323051	Plate w/Post 31	328964	Lever 54	330682	Tabulation Assembly, Vertical 2,13
323052	Guide, Paper 45	328967	Bushing 13	330684	Contact Assembly 14
323053	Alarm Assembly, Paper Out 31	328969	Spacer 13	330713	Guide, Paper 115
323070	Cam 64	328970	Gear w/Sleeve 13	330856	Alarm Assembly, Low Paper 31
323077	Spacer 31	328971	Gear, 84T 13	322258	Shaft 8
323078	Lever w/Hub 31	328972	Disc 13	332721	Carnshaft 15
323508	Box Assembly, DE Type 43	328973	Pointer 13		
		328974	Screw, 4-40 Spl 13		
		328975	Bushing 13		

## NUMERICAL INDEX (Continued)

Part Number	Description and Page Number	Part Number	Description and Page Number	Part Number	Description and Page Number
332722	Clutch Assembly, Codebar 15	332997	Spacer, Clutch 15	344958	Spring 35
332813	Plate 58	333478	Box Assembly, DY Type 43	344974	Modification Kit 47,48
332814	Cable Assembly 58	333520	Modification Kit 2,58	344975	Cable 48
332815	Lever 58	334440	Guide, Form 58	344993	Cover, Contact 14
332887	Plate 54	343938	Arm, Slide 36	345621	Switch 58
332888	Deflector 67	343939	Bracket, Spring 36	345510	Contact Assembly w/Cover 1
		344717	Switch 32	345511	Post 14

35 SEND - RECEIVE KEYBOARD (LK)  
AND  
35 RECEIVE - ONLY BASE (LB)  
PARTS

PAINT FINISH COLOR CODE CHART			
COLOR	Finish Suffix		
	Smooth Finish	Textured Vinyl	Smooth Vinyl
Charcoal Gray	BZ		HA
Dark Covert Gray	FC		
Light Gray			HB
Light Olive Gray	<u>EW</u>		HF
Gray Green	BK	GA	

The double asterisk(\*\*) denotes a painted part.  
Suffix to be applied following the part number.

NOTE: For a complete list of 35 Keytops refer to SECTION 570-020-800TC

## TABLE OF CONTENTS

FIGURE	CONTENTS	PAGE	FIGURE	CONTENTS	PAGE
1	Base	3	20	176352 and 197019 Contact Box Assemblies	18
2	Base (Continued)	4	21	Answer Back Mechanism	19
3	Gearsets	5	22	Base (Wall Mounted)	20
4	144770 and 192046 Intermediate Gear Assemblies	5	23	178500 Motor Assembly and Mounting Components (Wall Mounted)	21
5	Bracket Mechanism (RO)	6	24	Keyboard Cover	22
6	158254 Function Bail Assembly (RO)	6	25	315869 Modification Kit to Add Electrical Keyboard Lock to Wall Mounted Unit	23
7	194994 Paper Feed-Out Assembly (RO)	7	26	319385 Modification Kit to Add Two-Speed Gear Shift Assembly 73.3 and 110 Baud (Rear View)	24
8	170340, 192501, 197000 and 305469 Function Bail Assemblies	7	27	319385 Modification Kit to Add Two-Speed Gear Shift Assembly 73.3 and 110 Baud (Rear View) (Continued)	25
9	Keyboard Mechanism	8	28	Cable Components	26
10	Codebar Mechanism (Non Parity)	9	29	Keytops and Keylevers	27
11	Codebar Mechanism (Even Parity)	10	30	Keytops (Continued)	28
12	Codebars (Even Parity)	11	31	Keytops (Continued)	29
13	170332 Universal Bail Assembly	12	32	Keytops (Continued)	30
14	Ball Lock Mechanism	12	33	Keytops (Continued)	31
15	Signal Generator Frame Mechanism	13	34	Keytops (Continued)	32
16	Signal Generator Shaft Mechanism	14		Numerical Index	33
17	Signal Generator Front Plate Mechanism	15			
18	Signal Generator Rear Plate Mechanism	16			
19	Signal Generator Rear Plate Mechanism (Continued)	17			

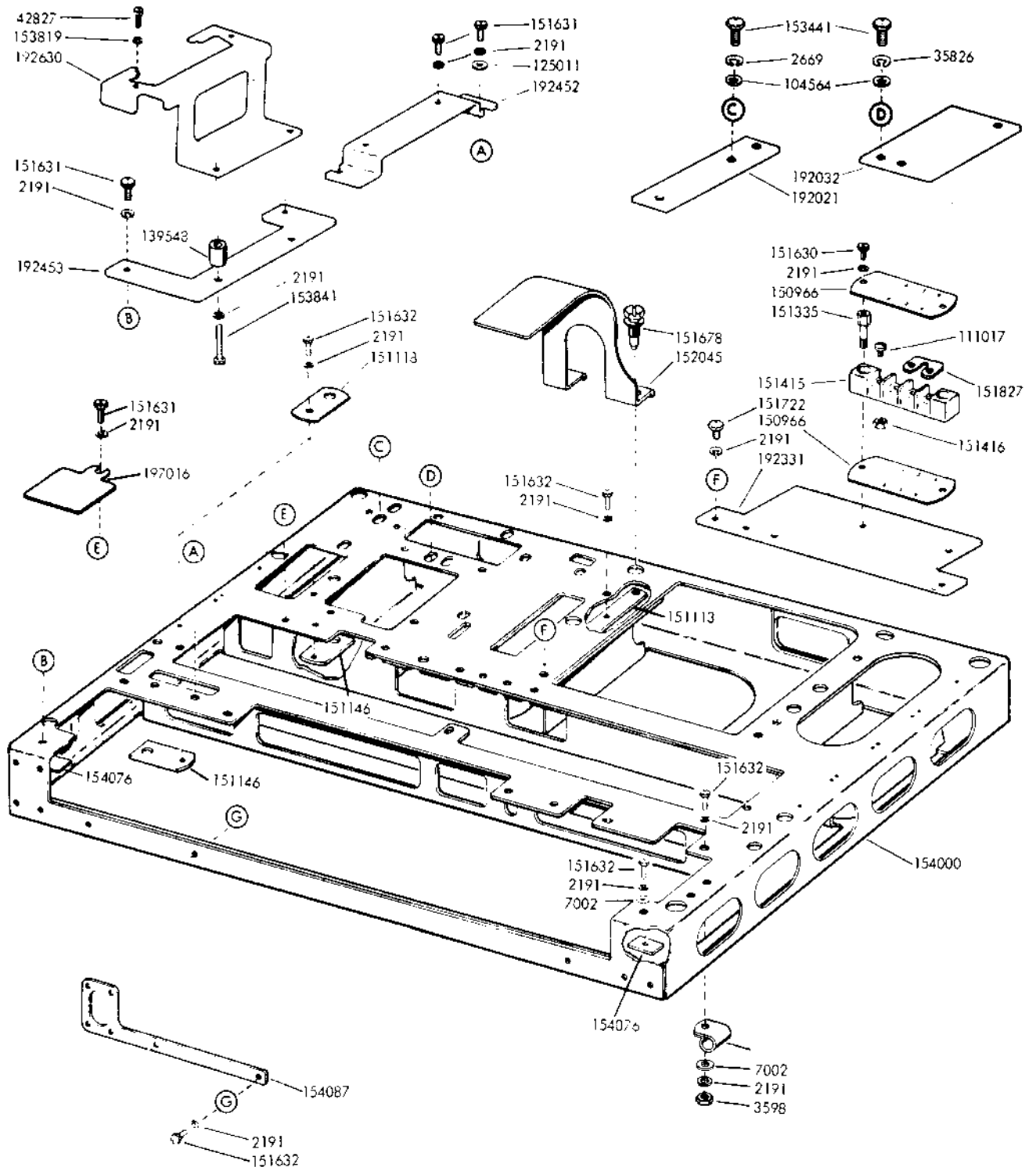

FIGURE 1. BASE

SECTION 574-221-800TC

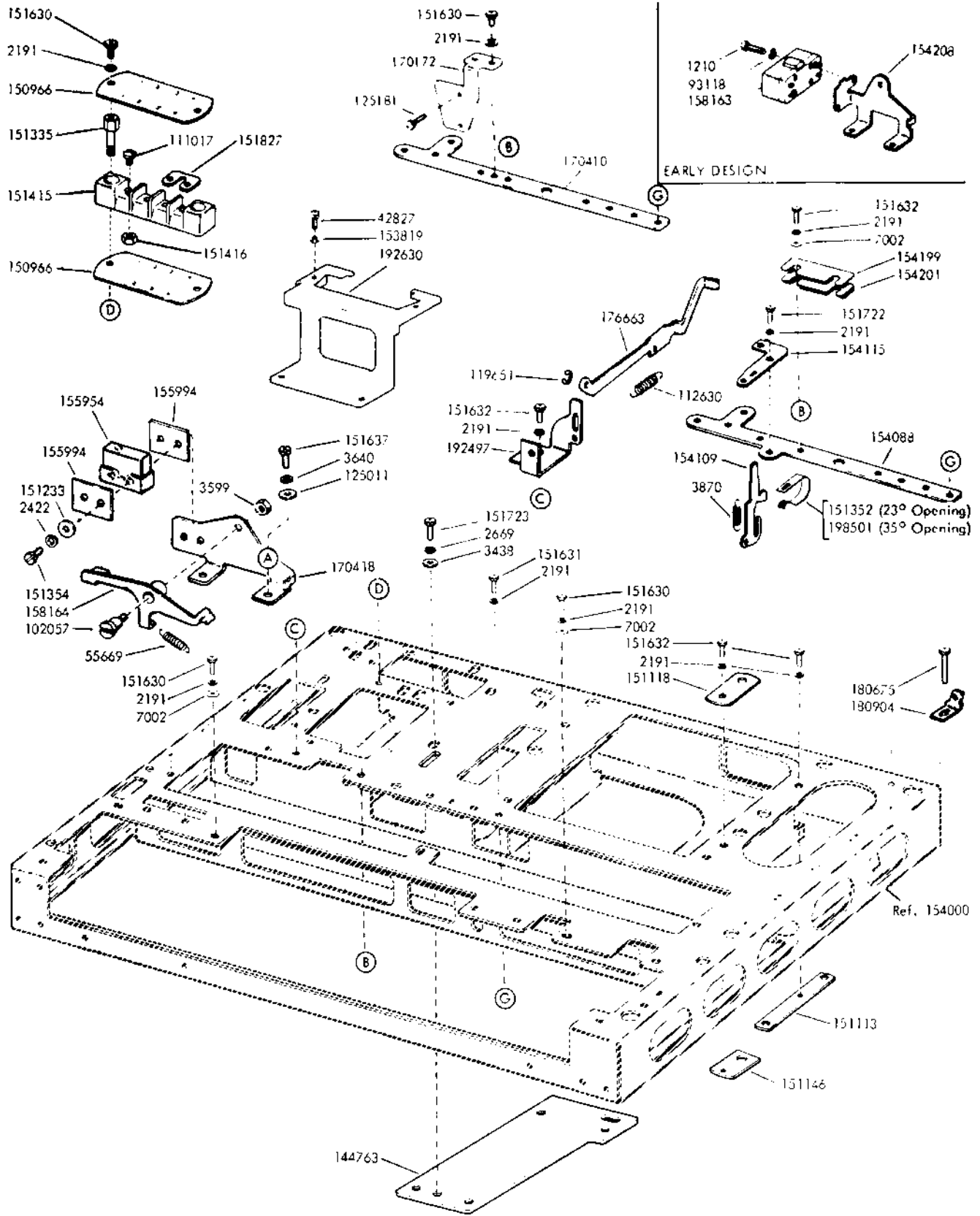
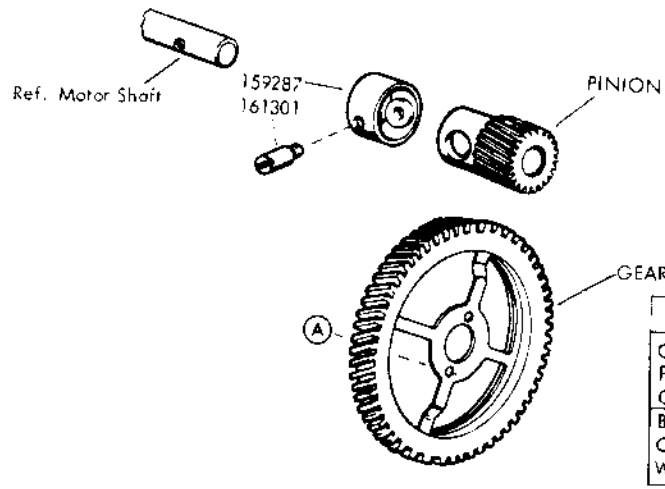

FIGURE 2. BASE (Continued)





GEAR CHART			
Gear Set	161295	311488	315865
Pinion	159284	311490	315861
Gear	159285	311491	315860
Baud	11.0	73.3	75
Code	11.0	11.0	11.0
WPM	100	67	100

FIGURE 3. GEARSETS

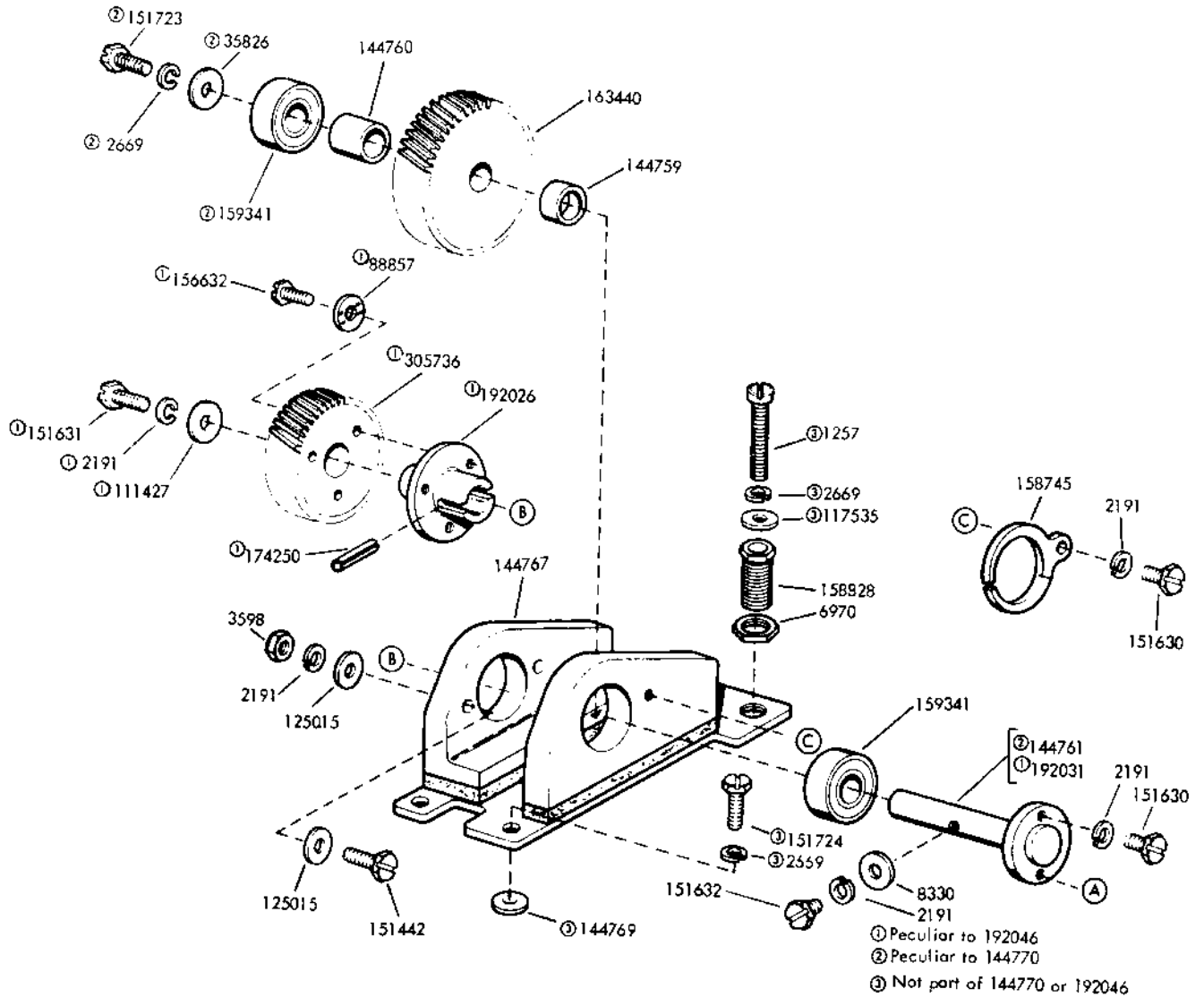

FIGURE 4. 144770 AND 192046 INTERMEDIATE GEAR ASSEMBLIES

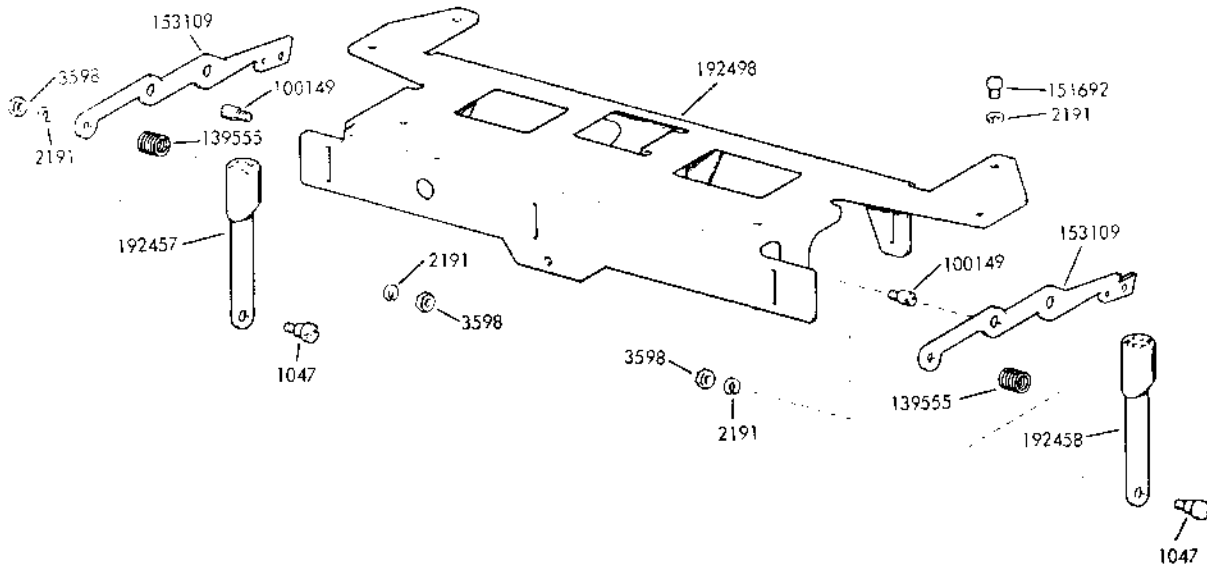

FIGURE 5. BRACKET MECHANISM (RO)

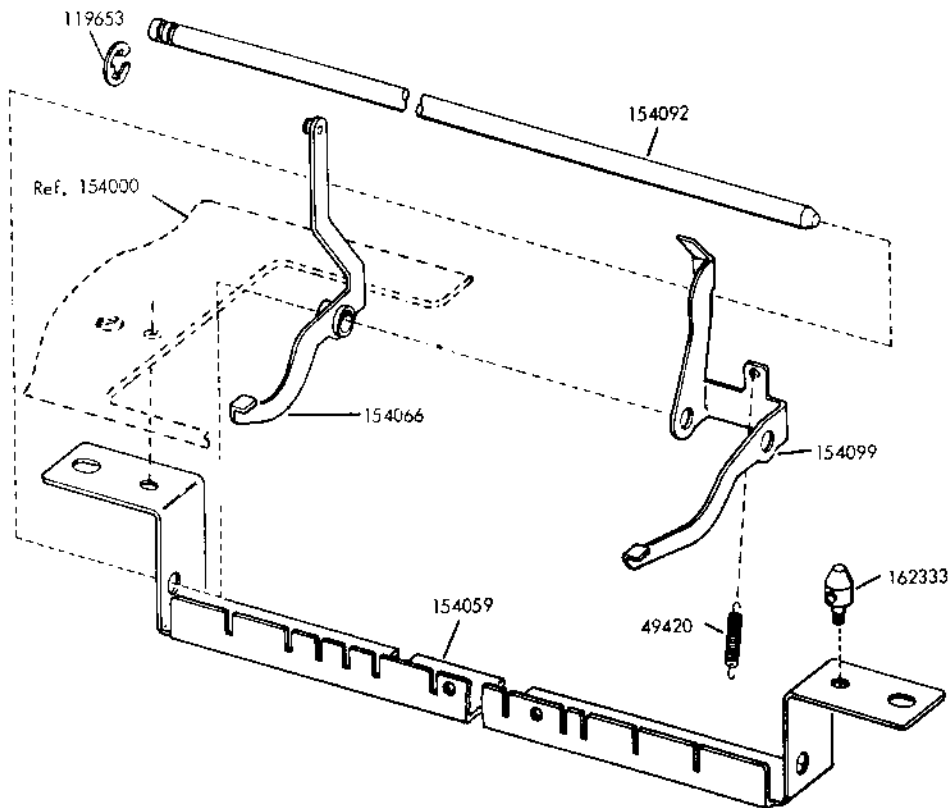

FIGURE 6. 158254 FUNCTION BAIL ASSEMBLY (RO)

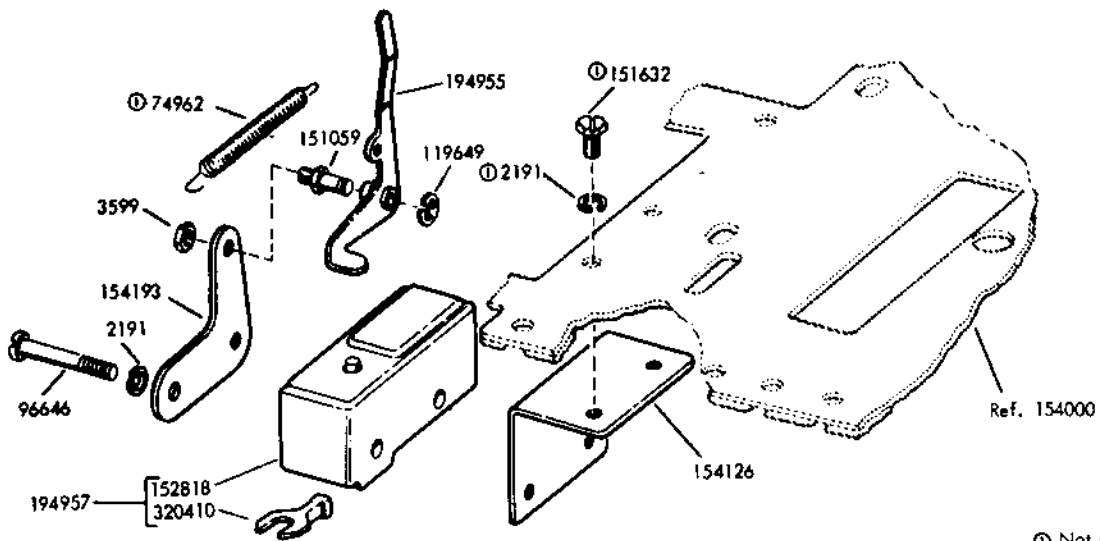
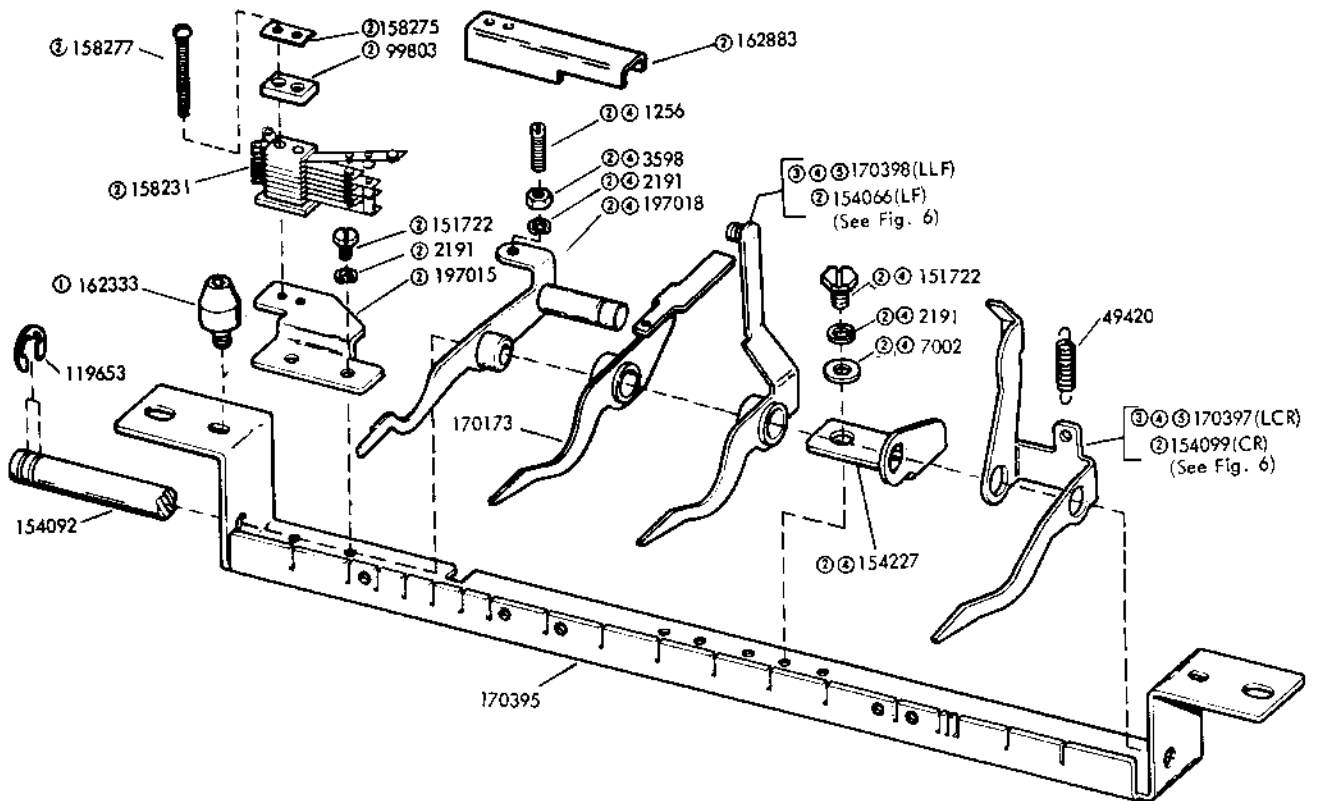

FIGURE 7. 194994 PAPER FEED-OUT ASSEMBLY (RO)

① Not part of 194994



- ① Not part of the Function Bail Assembly
- ② Peculiar to 305469 (RO)
- ③ Peculiar to 170340 (KSR)
- ④ Peculiar to 197000 (KSR)
- ⑤ Peculiar to 192501

FIGURE 8. 170340, 192501, 197000 AND 305469 FUNCTION BAIL ASSEMBLIES

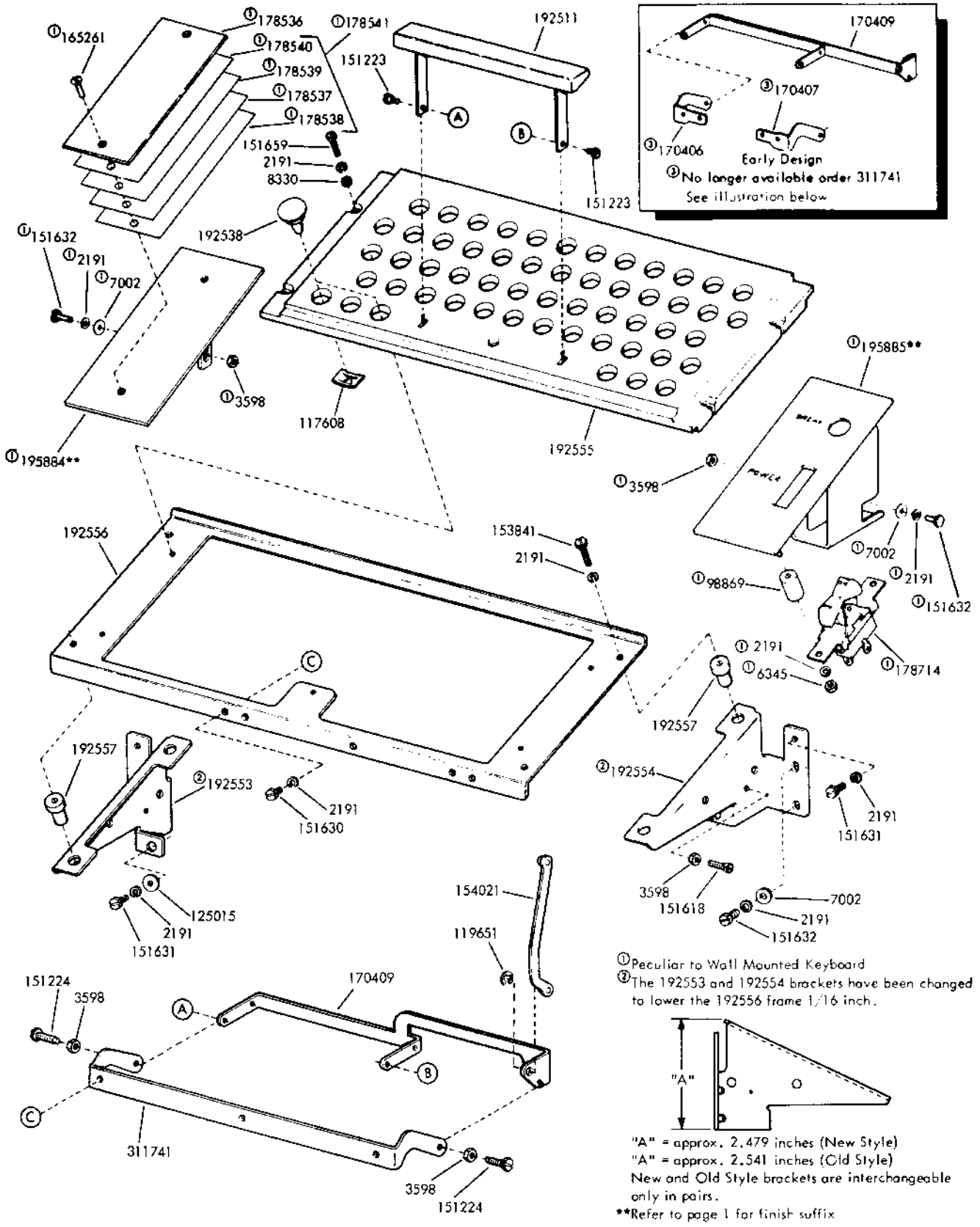

FIGURE 9. KEYBOARD MECHANISM

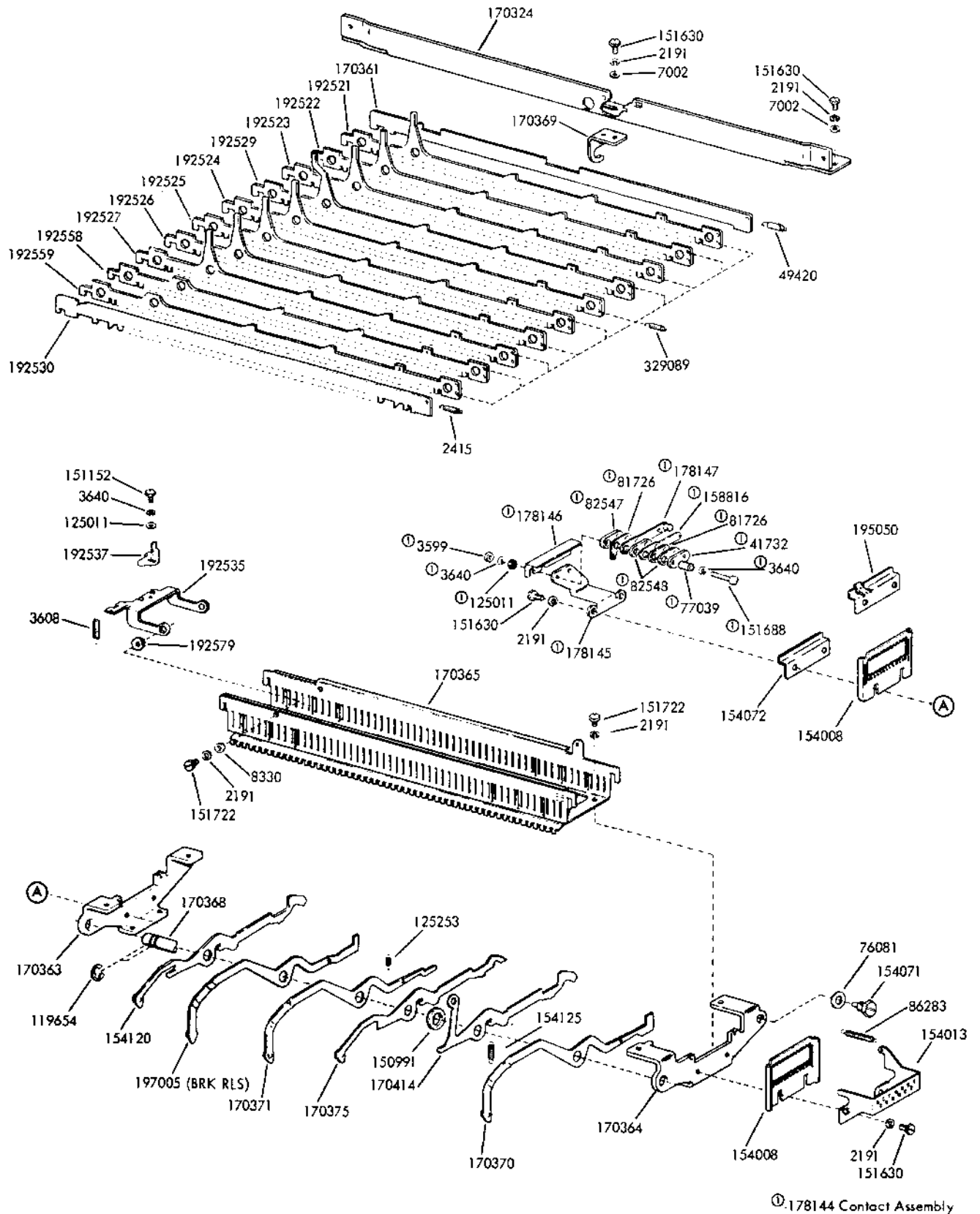
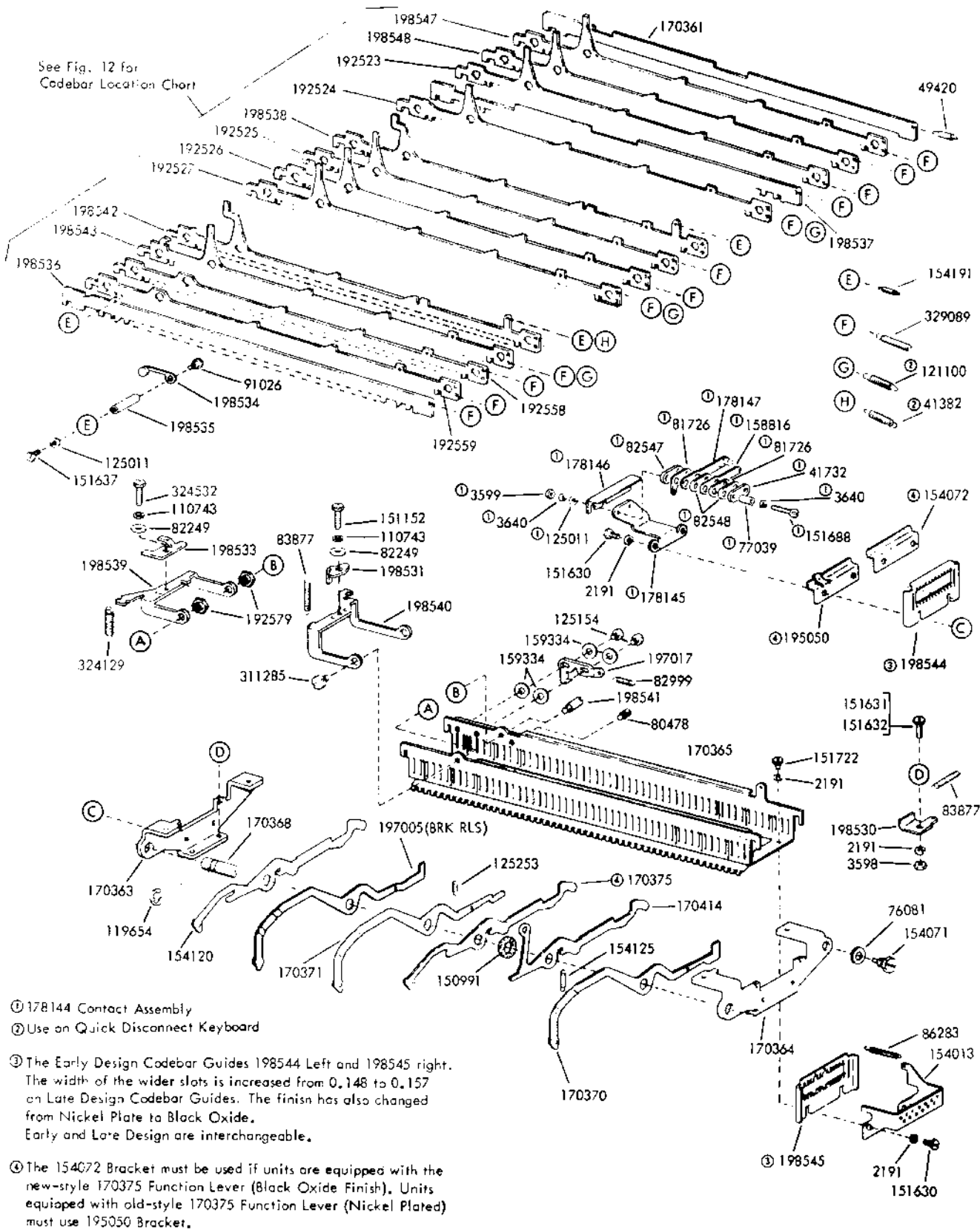

FIGURE 10. CODEBAR MECHANISM (Non Parity)



- ① 178144 Contact Assembly
- ② Use an Quick Disconnect Keyboard
- ③ The Early Design Codebar Guides 198544 Left and 198545 right. The width of the wider slots is increased from 0.148 to 0.157 on Late Design Codebar Guides. The finish has also changed from Nickel Plate to Black Oxide. Early and Late Design are interchangeable.
- ④ The 154072 Bracket must be used if units are equipped with the new-style 170375 Function Lever (Black Oxide Finish). Units equipped with old-style 170375 Function Lever (Nickel Plated) must use 195050 Bracket.

FIGURE 11. CODEBAR MECHANISM (Even Parity)

Location Chart for Even Parity - Codebars											
Codebar Location	Shift Lock	⑧	⑦	⑥	⑤	④	③	②	①	①	①
Common Code See Figure 8	198536 See Detail Below	198543 (8)	198542 (8I)	192527 (7)	192526 (6)	192525 (5)	198538 (5I)	192524 (4)	192523 (3)	198548 (2A)	198547 (1A)
Escape II ②	198536 See Detail Below	198543 (8I)	198542 (8I)	308431 (7A)	308430 (6A)	192525 (5)	198538 (5I)	192524 (4)	308429 (3A)	198548 (2A)	192521 (1)
Scientific Data System Auto - IDP ③	311211 See Detail Below	311208 (8S)	311533 (8U)	311531 (7R)	311201 (1S)	311205 (5S)	311209 (5T)	311202 (2S)	311204 (4S)	311203 (3S)	311206 (6S)
Scientific Data System - SIGMA Series ④	320480 See Detail Below	320478 (8D)	324580 (8L)	320476 (6D)	320477 (7D)	320475 (5D)	320479 (5E)	320474 (4D)	320473 (3D)	320472 (2D)	320471 (1D)

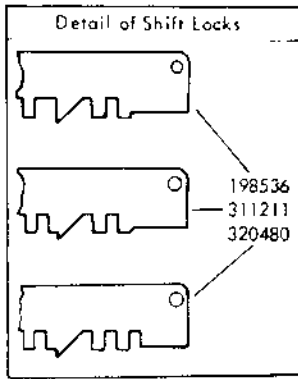

Codebars viewed at Right Hand Guide

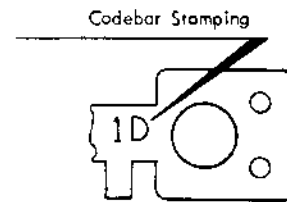
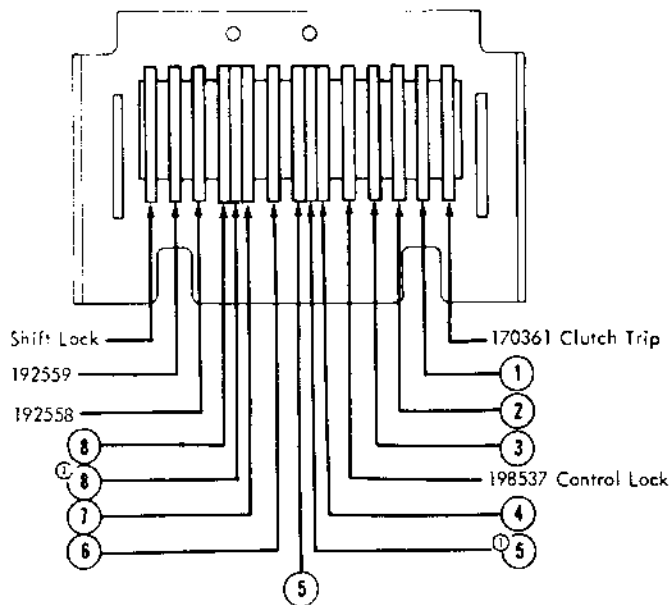

- ① Inversion
- ② Peculiar to Escape II
- ③ Used with Character Counter
- ④ Use on SDS SIGMA series

FIGURE 12. CODEBARS (Even Parity)

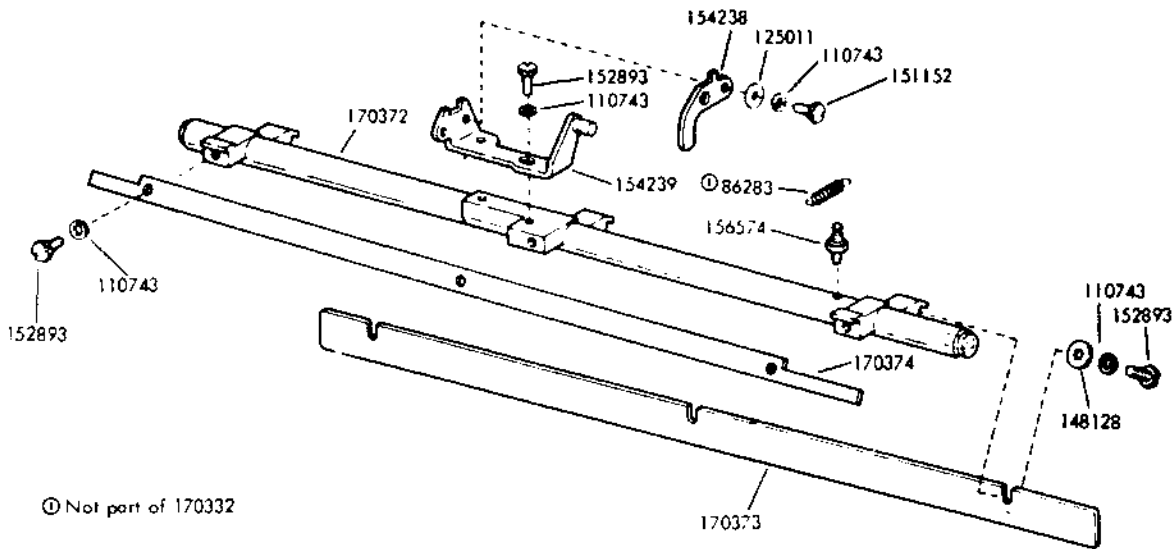

FIGURE 13. 170332 UNIVERSAL BAIL ASSEMBLY

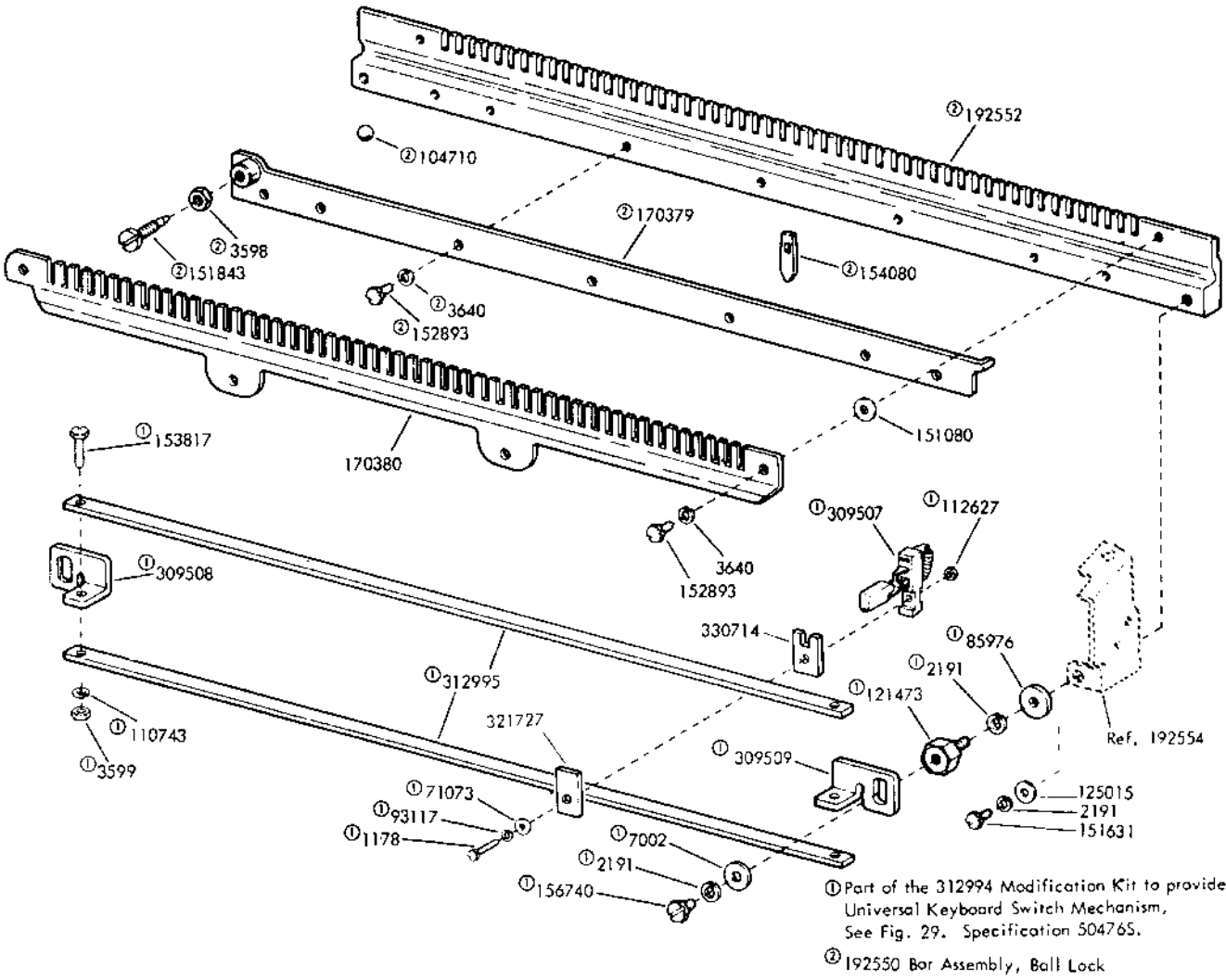
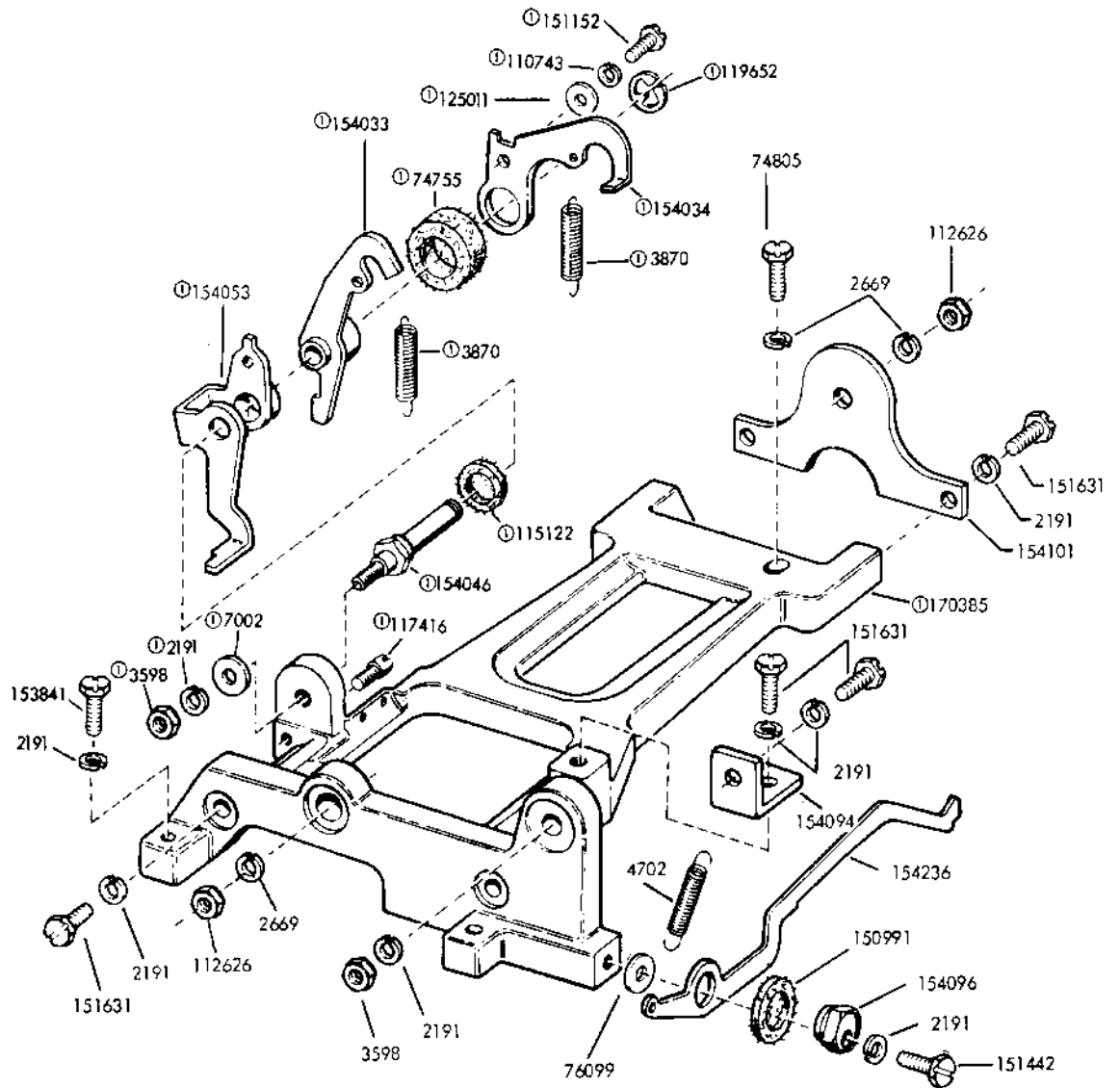

FIGURE 14. BALL LOCK MECHANISM





①154164 Frame Assembly

FIGURE 15. SIGNAL GENERATOR FRAME MECHANISM

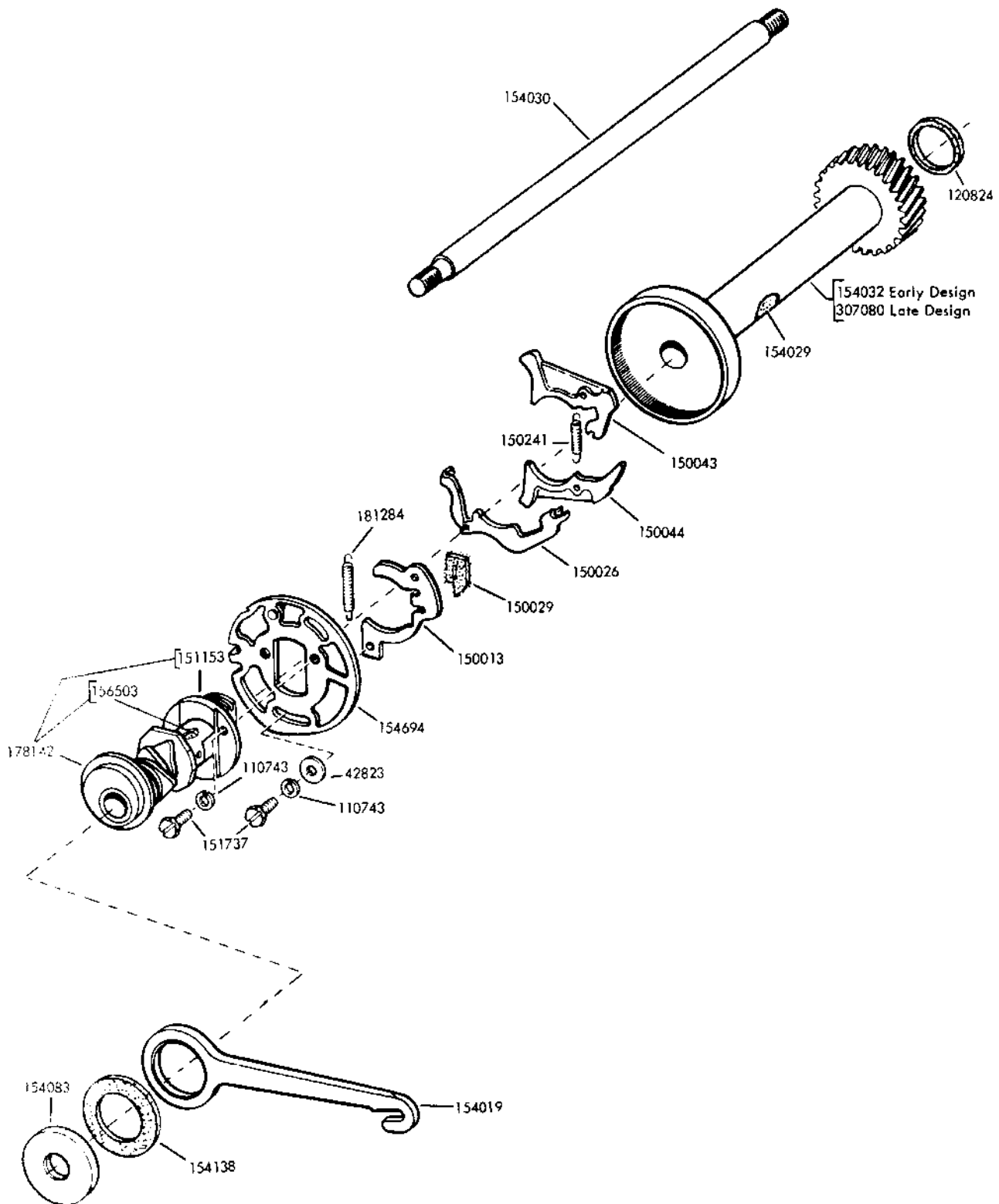

FIGURE 16. SIGNAL GENERATOR SHAFT MECHANISM

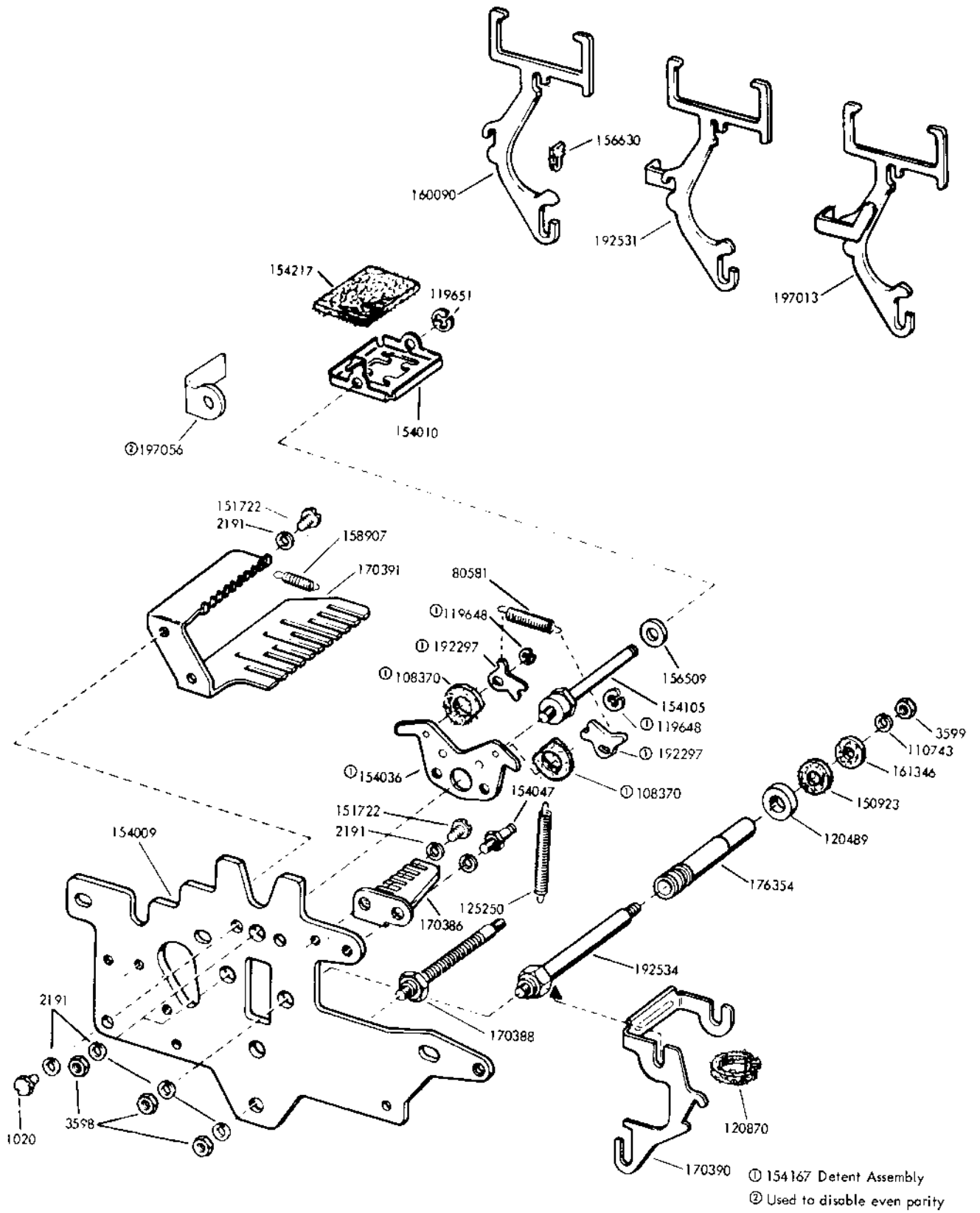

FIGURE 17. SIGNAL GENERATOR FRONT PLATE MECHANISM

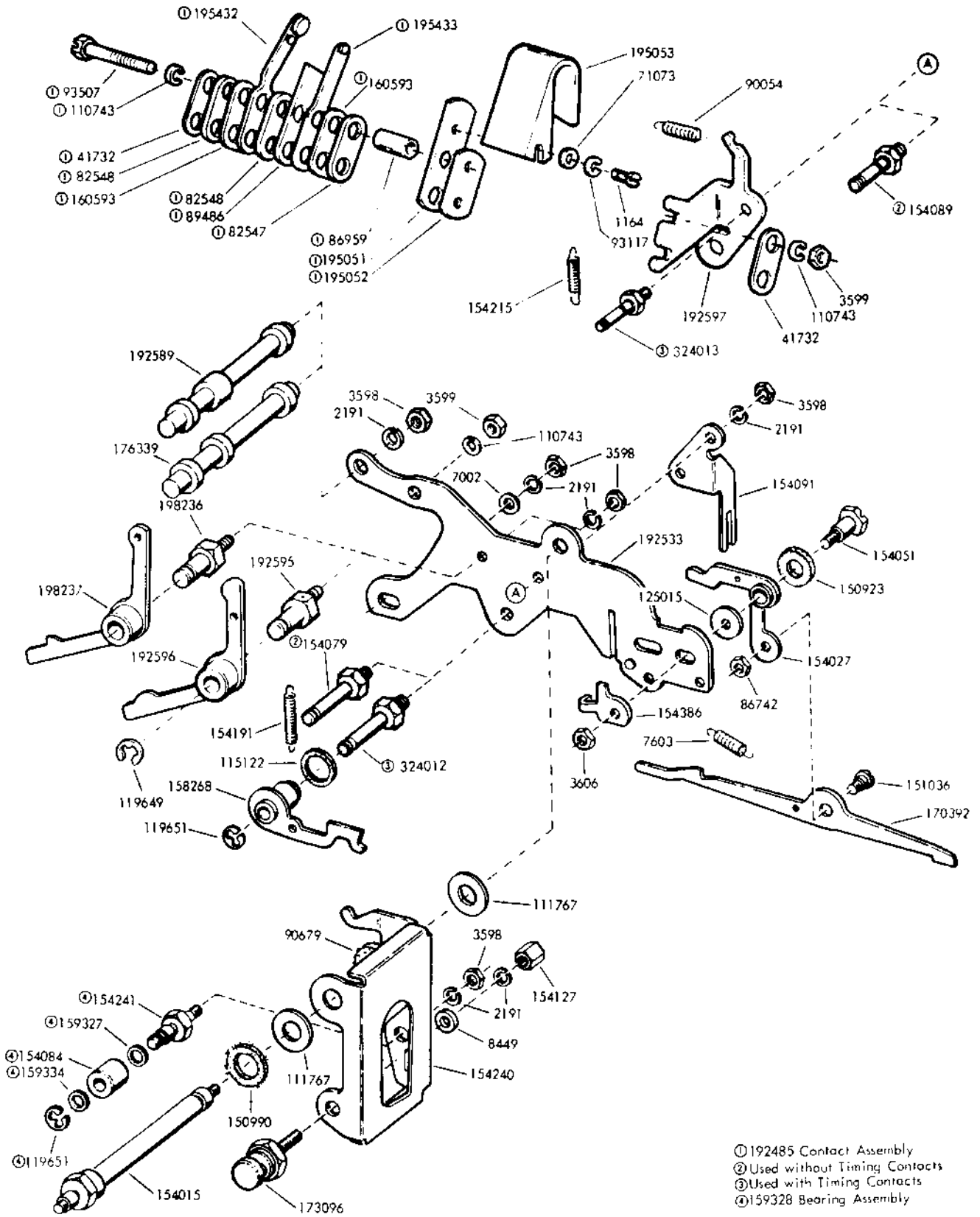
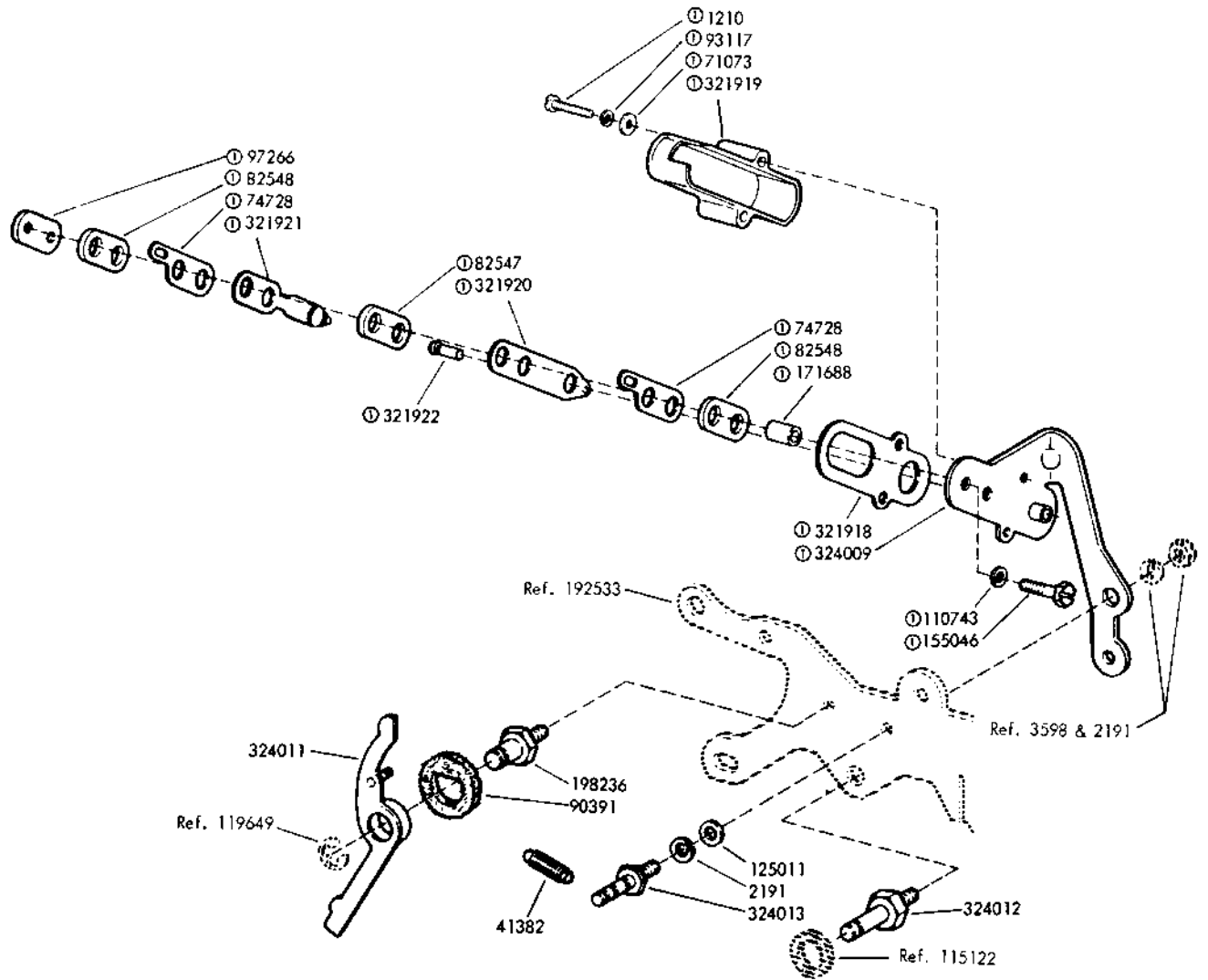

FIGURE 18. SIGNAL GENERATOR REAR PLATE MECHANISM



① 324010 Contact Assembly

FIGURE 19. SIGNAL GENERATOR REAR PLATE MECHANISM (Continued)

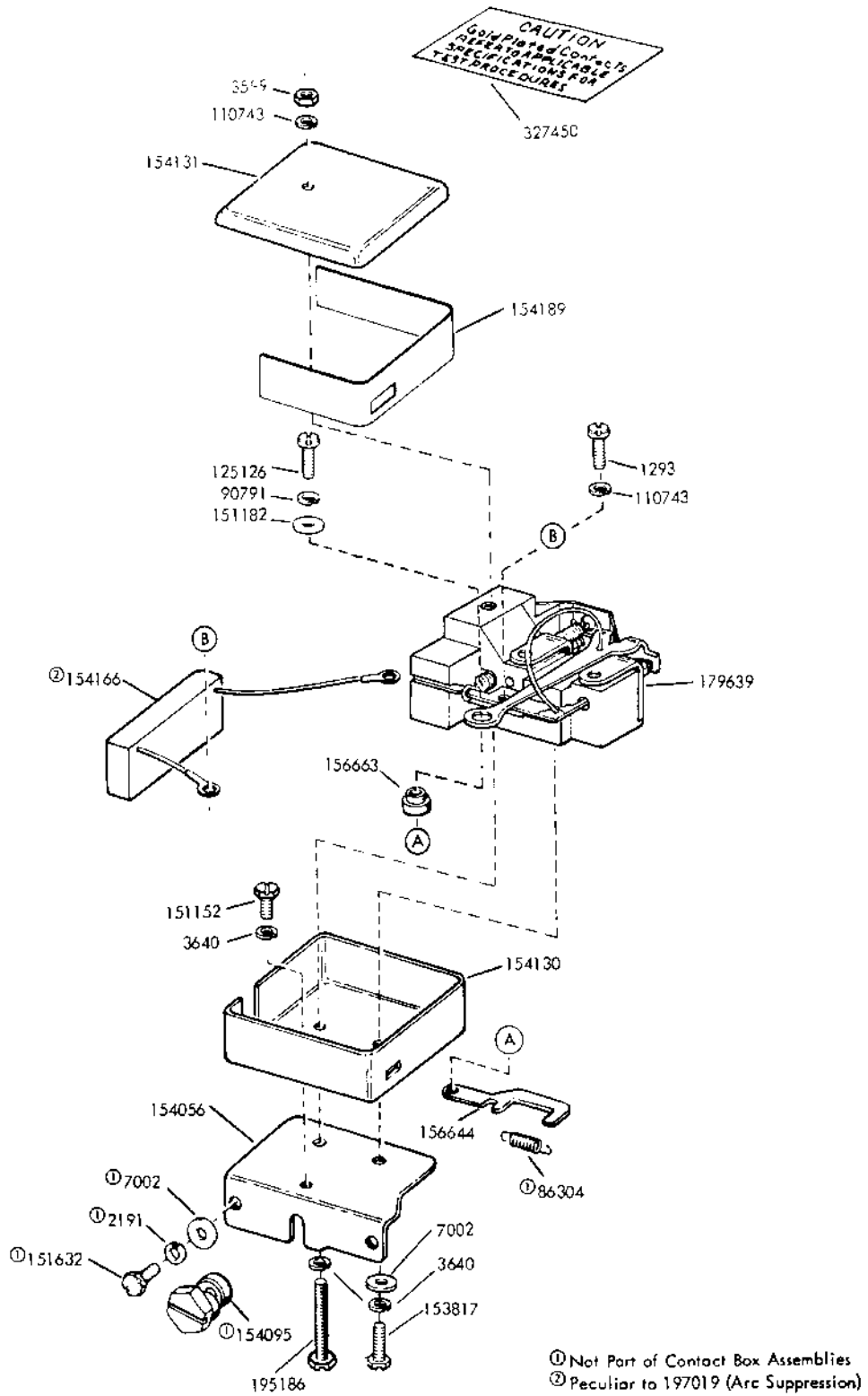

FIGURE 20. 176352 AND 197019 CONTACT BOX ASSEMBLIES

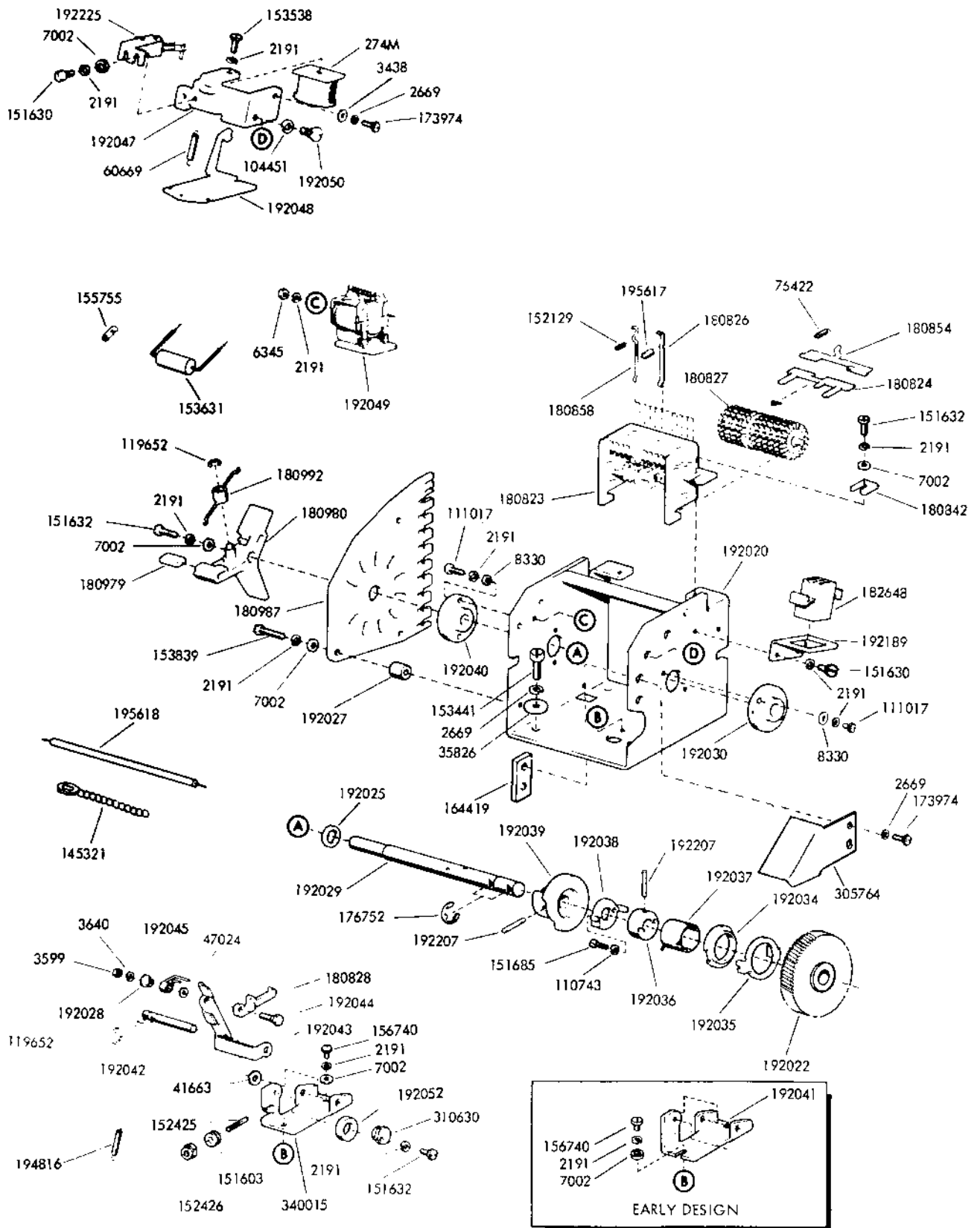

FIGURE 21. ANSWER BACK MECHANISM

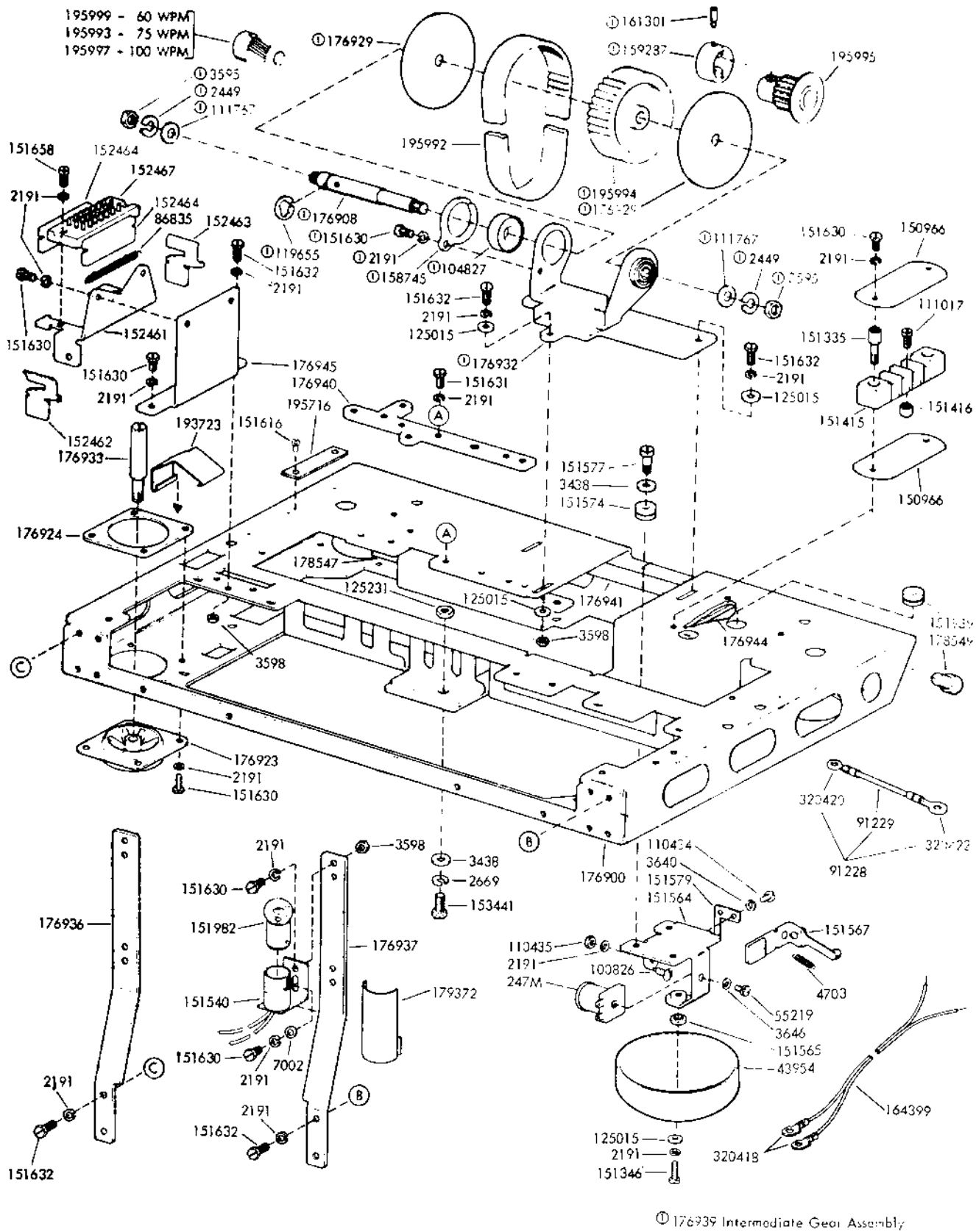
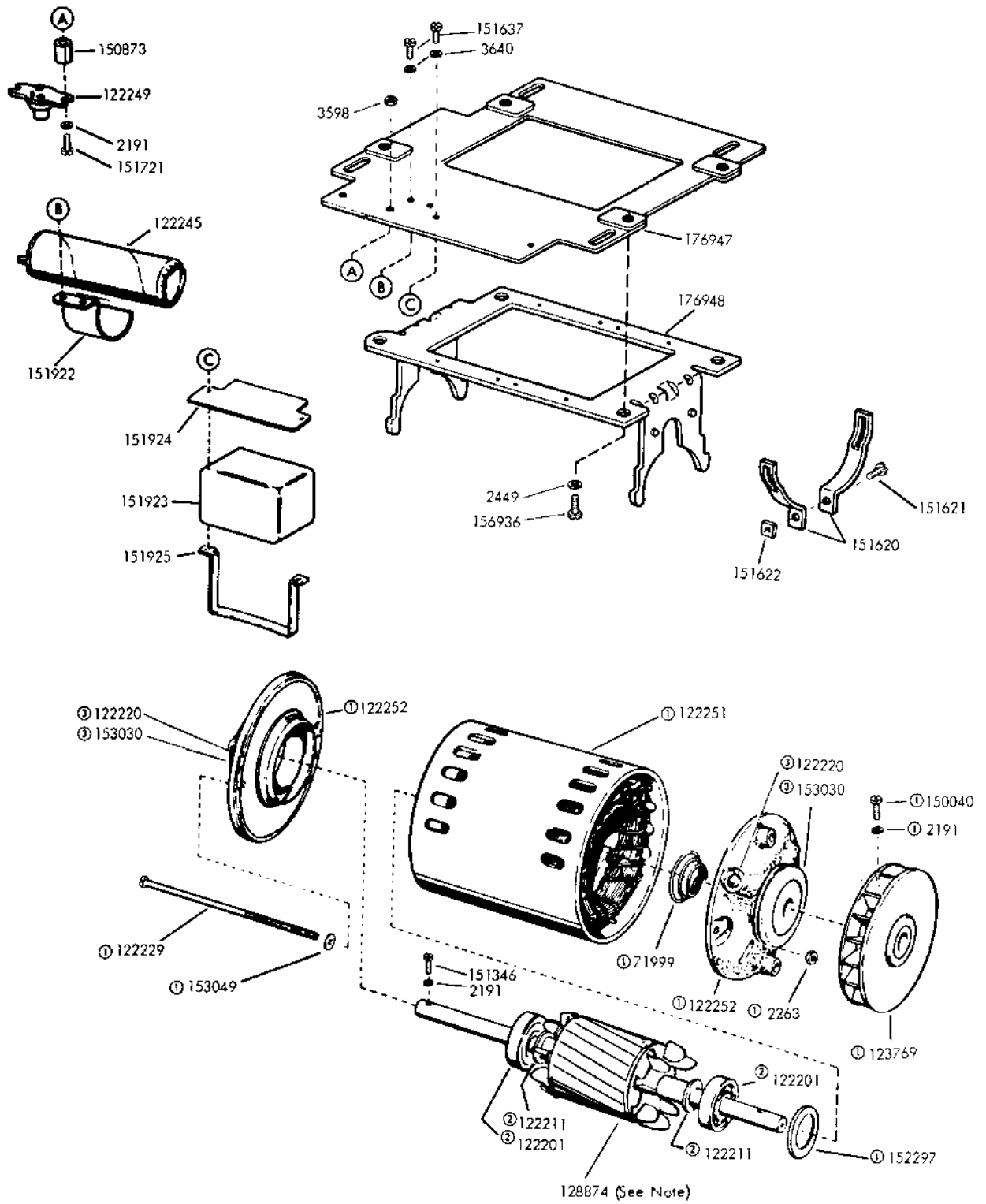

FIGURE 22. BASE (WALL MOUNTED)





**NOTE:** Early Design riveted Copper Bars.  
Late Design Die Cast Aluminum

- ① 178500 Motor Assembly
- ② Supplied w 128874 Rotor Assembly
- ③ Supplied w 122252 End Shield

FIGURE 23. 178500 MOTOR ASSEMBLY AND MOUNTING COMPONENTS (WALL MOUNTED)

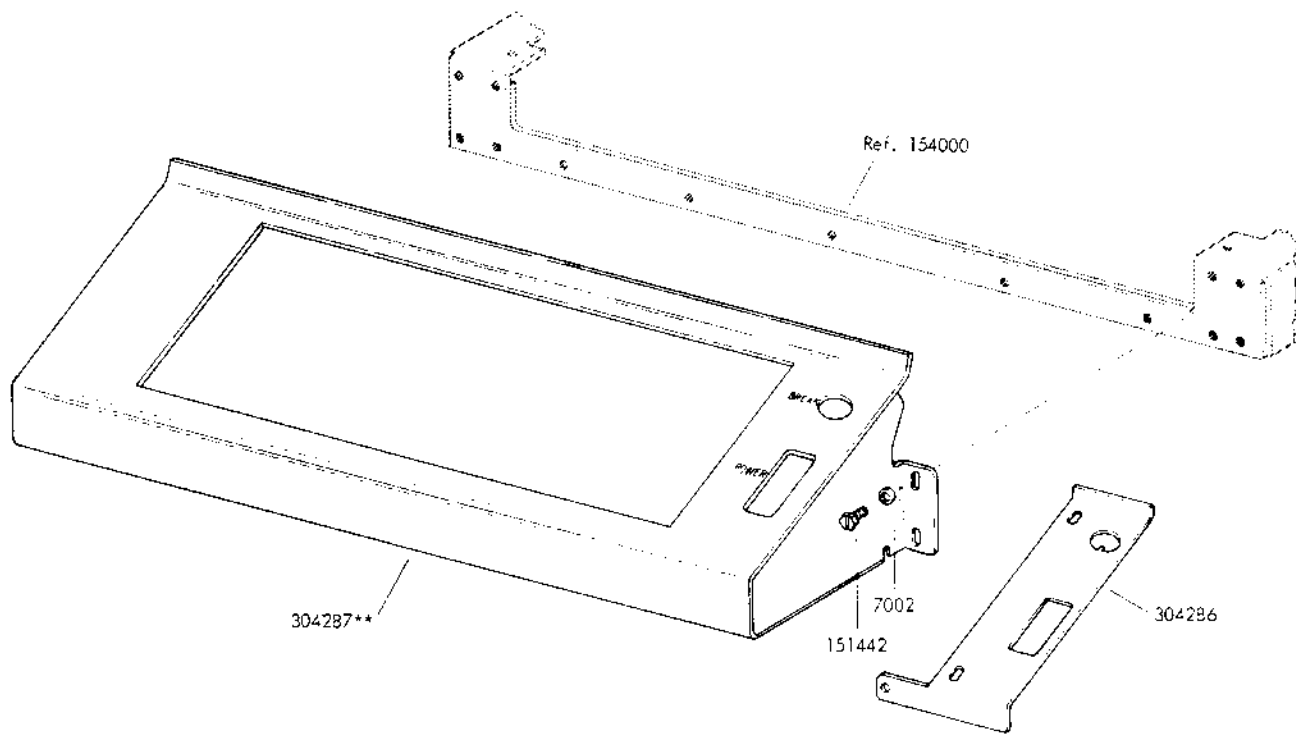

\*\* Refer to page 1 for finish suffix

FIGURE 24. KEYBOARD COVER

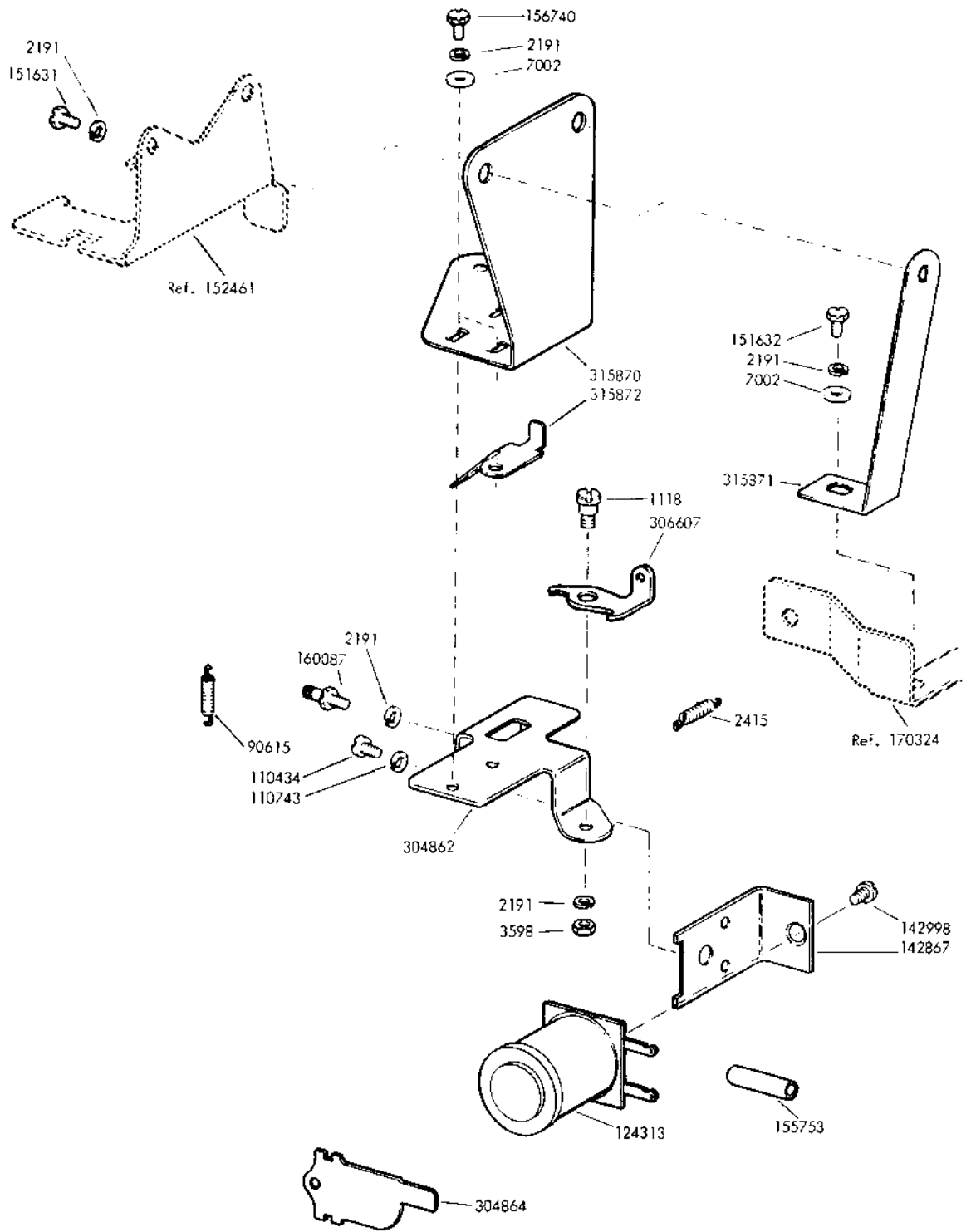

Specification 50491S

FIGURE 25. 315869 MODIFICATION KIT TO ADD ELECTRICAL KEYBOARD LOCK TO WALL MOUNTED UNIT

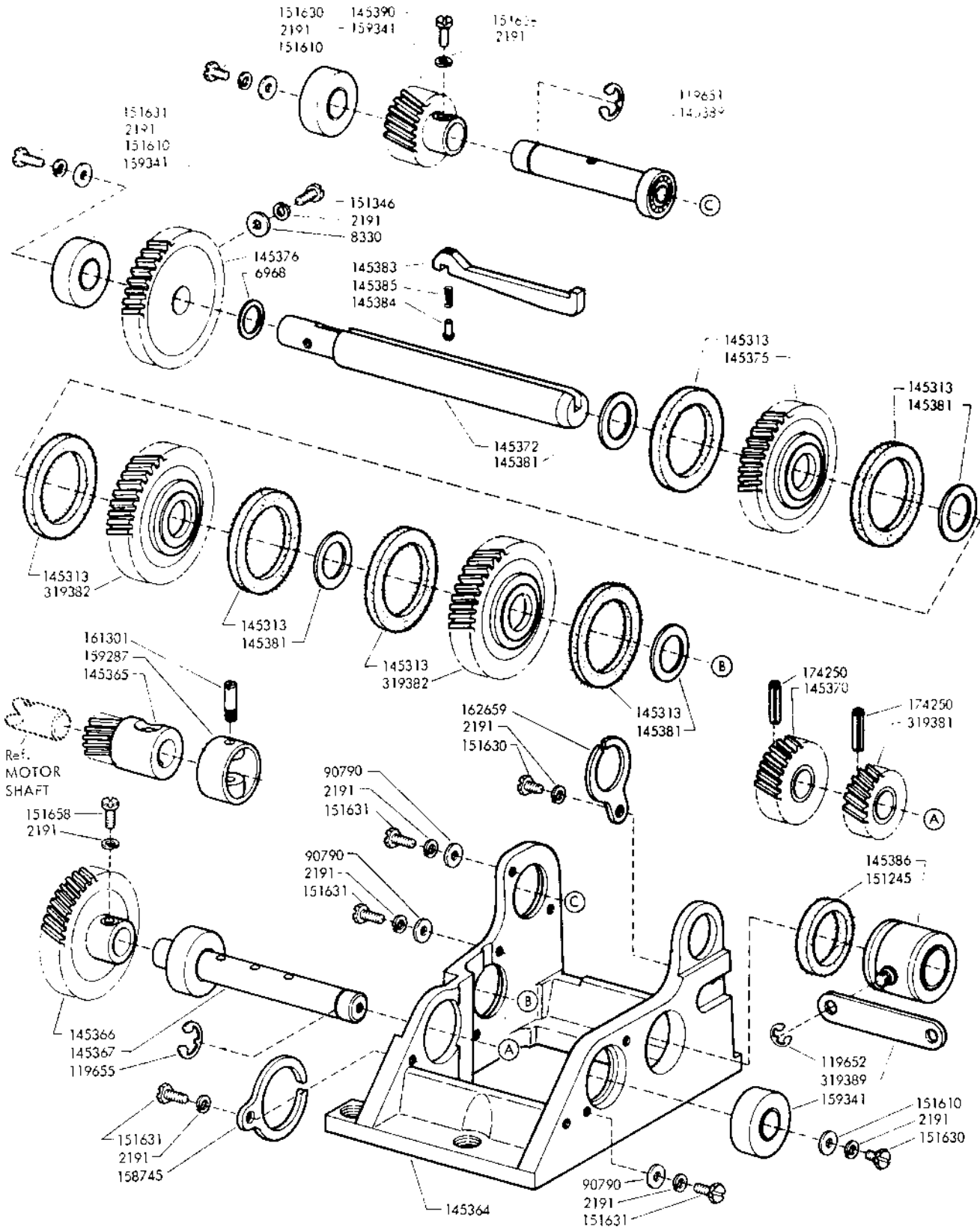

FIGURE 26. 319385 MODIFICATION KIT TO ADD TWO-SPEED GEAR SHIFT ASSEMBLY 73.3 and 110 BAUD (Rear View)

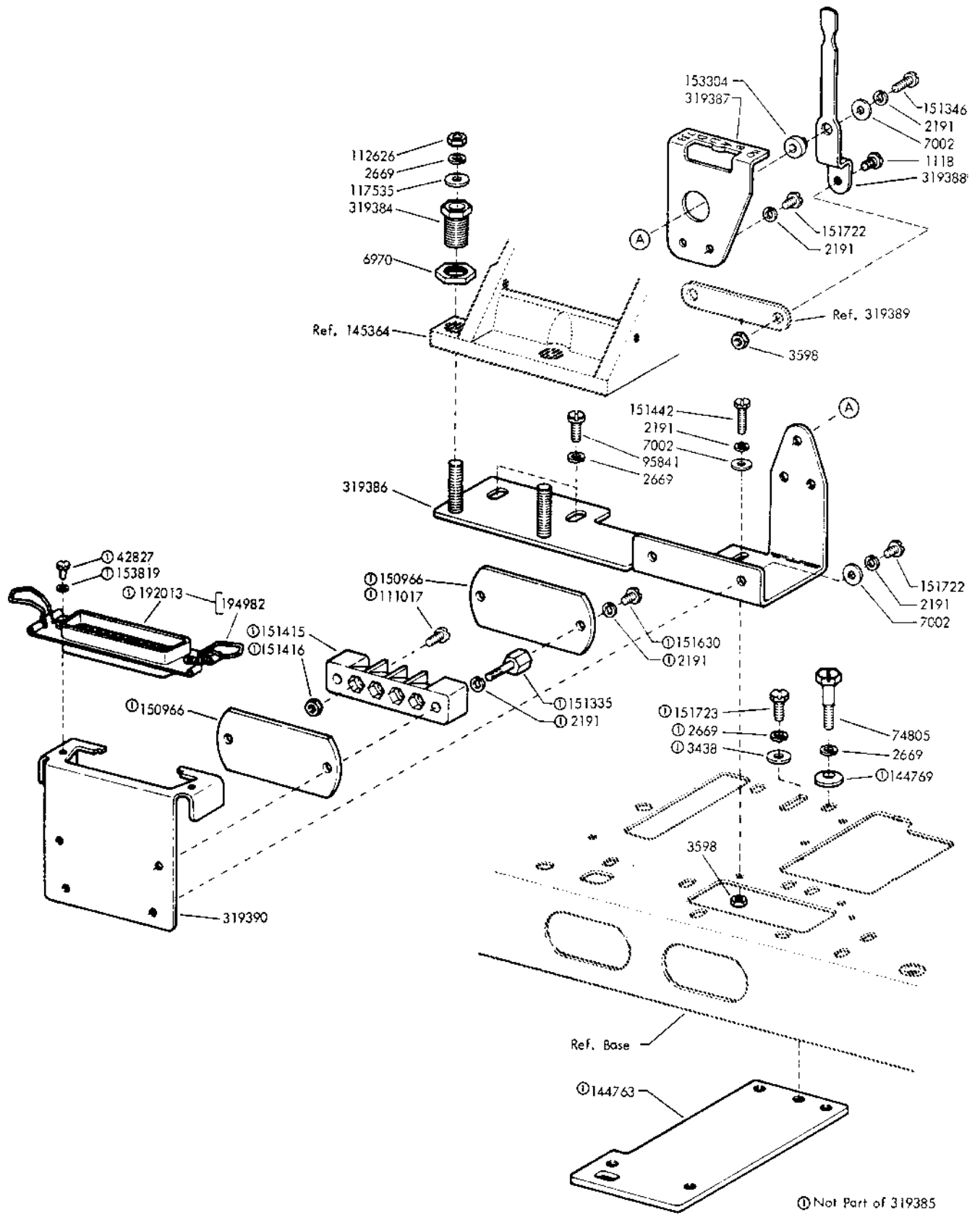

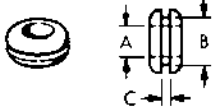

FIGURE 27. 319385 MODIFICATION KIT TO ADD TWO-SPEED GEAR SHIFT ASSEMBLY 73.3 and 110 BAUD (Rear View) - (Continued)

CABLE CLAMPS	
	
Part No.	I.D.
121242	1/8
121243	3/16
121244	1/4
121245	5/16
121246	3/8
121247	7/16
121248	1/2
121249	5/8
121250	3/4
121251	1

INSULATING SLEEVES		
		
Part No.	I.D.	Length
155750	3/32	1/2"
155751	1/8	1"
155752	5/64	1/2"
155753	1/8	1/2"
155754	1/16	1/2"
155755	11/64	5/8"

GROMMETS			
			
Part No.	A	B	C
154156	3/16	5/16	1/32

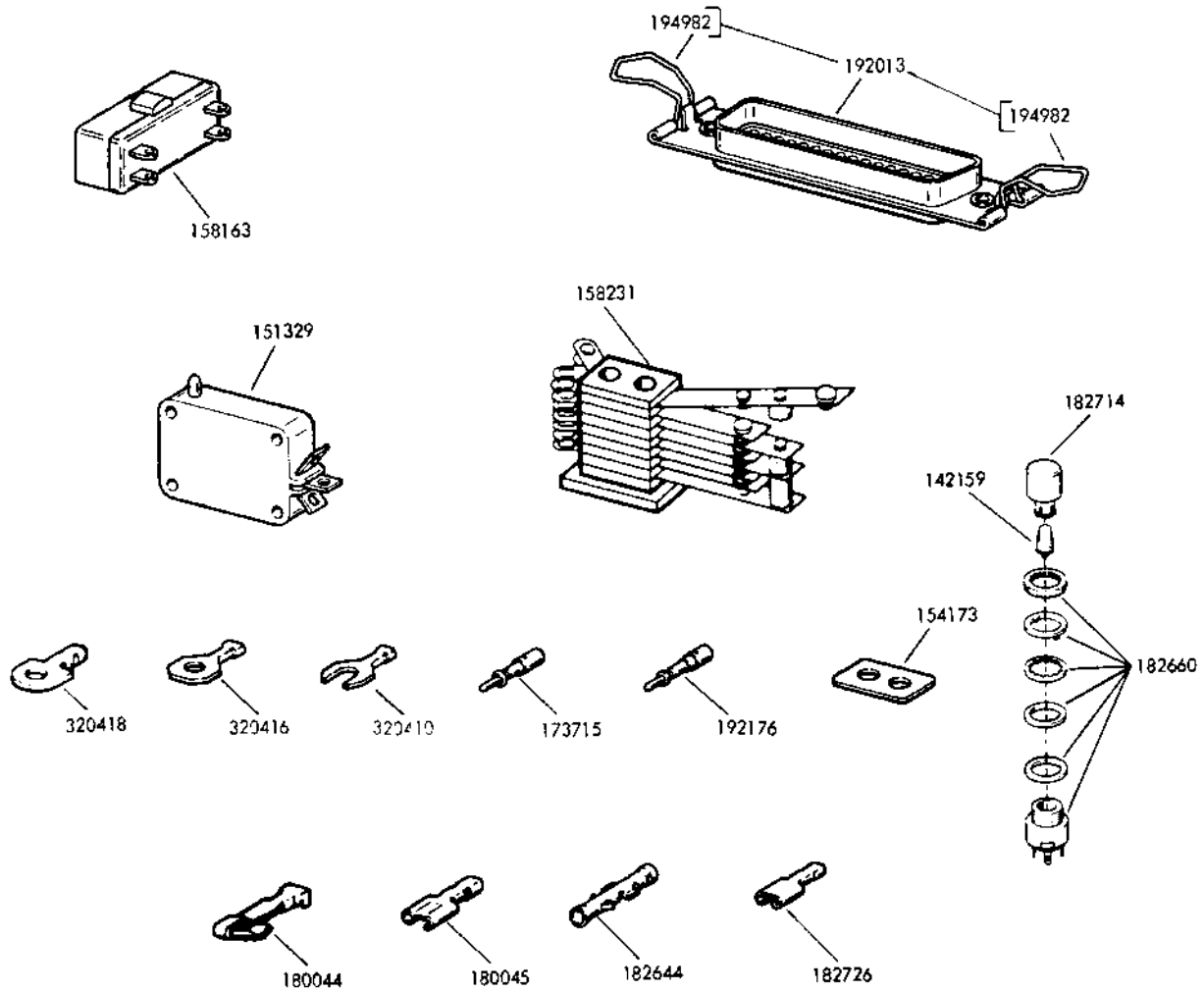

FIGURE 28. CABLE COMPONENTS



KEYTOP DESCRIPTION	PART NO.	KEYTOP DESCRIPTION	PART NO.	KEYTOP DESCRIPTION	PART NO.	KEYTOP DESCRIPTION	PART NO.
① LOC LF	151249	BELL	180341	KBD UNLK	184715	TAB TX	185091
① LOC CR	151250	TAB	180373	ERROR	184719	⑤ CTRL	185159
① REPT	151254	CAR RET	180380	CLR KYBD	184734	C R EOB ⑤	185190
① LOC BSP	153280	ESC	180382	BLK	184748	⑤ TAB	185194
RUB OUT	180201	BACK SPACE	180402	FORM OUT	184819	⑤ MTAB	185195
RE TURN	180202	EOT	180440	DE LETE	184842	RUN OUT	185211
LINE FEED	180203	DIV	180441	THIN ADD	184846	BLANK FIGS	185222
HERE IS	180206	STORE	180442	SPACE EM	184847	SPACE	185223
BREAK	180207	TYPE ORD	180443	THIN SPACE	184848	NEW LINE	185227
REPT	180208	SECT	180444	SPACE EN	184849	EOM	185228
FIGS	180210	① CTRL	161253	ELEV	184858	TAPE FEED	185268
LTRS	180211	③ CTRL	181971	TAPE	184859	CNFM	194226
ALT MODE	180257	C R EOB	183920	INT	184862	BRK-RLS	197040
No Characters	180299	④ No Characters	184347	SKIP	184871		

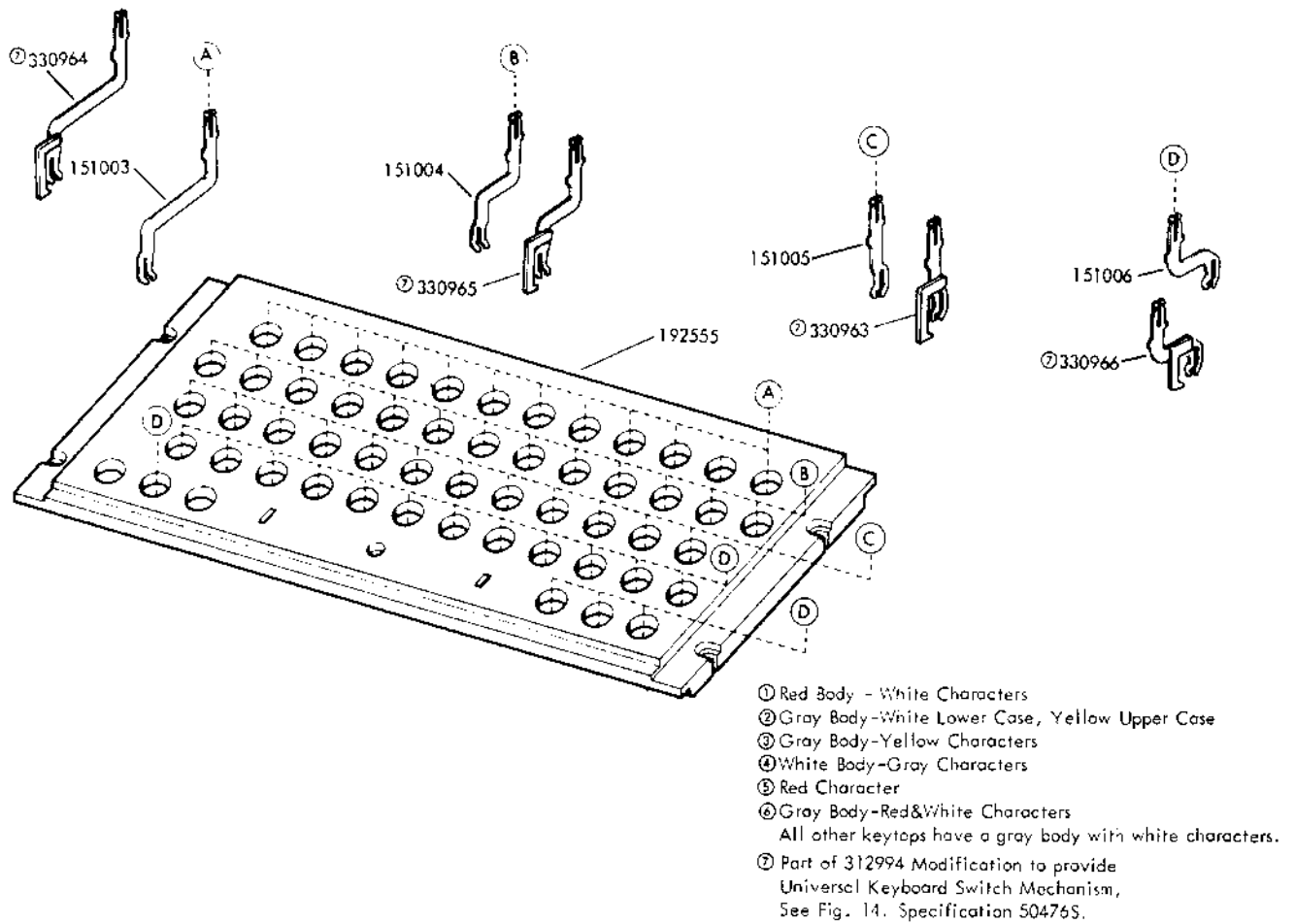

FIGURE 29. KEYTOPS AND KEYLEVERS

KEYTOP DESCRIPTION	PART NO.	KEYTOP DESCRIPTION	PART NO.	KEYTOP DESCRIPTION	PART NO.	KEYTOP DESCRIPTION	PART NO.
A	180181	C O	185238	F %	180386	I TRAN ③	185205
A -	180223	C ENX	185243	F <	180410	I TAB ③	185271
A I	180391	④ C EOM	185286	F PRINT	180429		
A SOM	180427	C 48	185293	F S	180447		
A SOA	180435			f RU	184679	J	180187
② A SOM	183891			F +	184730	J BELL	180229
④ A	184343	D EOT	180183	F ENT	184801	J	180243
o	184675	D +	180255	F →	185232	J	180390
o B	185059	D S	180240	F DR	185295	J	184660
(A) IO	185143	D WRU	180277			J =	185213
④ A SOH ④	185148	D	180278			J /	185235
A SOH	185169	D EOT	180370	G BELL	180185		
A ↑	185230	D )	180409	G &L	180227		
A PA	185291	④ D	184346	G &	180242	K VT	180188
		d EOT	184678	G	180274	K (	180230
		D ←	184729	G BELL	180372	K 1/2	180244
B	180194	D <	184823	G ⊙	180387	K	180280
B ?	180236	D EOT ③	185170	G ▼	180394	K VLS	180361
B 5 B	180249	D /	185231	G ¶	180411	K VJL	180430
B EOA	180381			② G BELL	183890	K BP	180449
B ▼▼	180392			g BELL	184681	K [	184664
B SOT	180434	E WRU	180173	G [	184727	K I	184731
B BELL	180455	E J	180215	G I	184824	K (VT	184803
④ B	184344	E	180259	④ G BEL ③	185173	K (VT	184870
b	184683	E c	180333	G ↘	185233	K ↗	184888
B c	184827	E WRU	180369	G BELL ③	185273	k	185080
B STX	184868	E [	180404			k <sup>l</sup>	185090
b +	185078	E PRINT	180424			K	185106
(B) YES	185144	② E WRU	183889	H	180186	K ]	185126
④ B STX ④	185166	e WRU	184663	H #L	180228	K <	185142
B ⊕	185240	E (	184725	H STOP	180378	K (VT ③	185171
B SOM	185242	E &	184745	H Ⓔ	180388	K -	185214
B RESET	185292	E ENQ	185146	H (	180396	K ←	185236
		E WRU ③	185175	H FE	180437		
		E COND ③	185200	H #	180448		
C	180192	E ENQ ③	185283	h	184682	L FORM	180189
C :	180234	E 4A	185294	H BS ③	185163	L )	180231
C WRU	180247			H ↓	185234	L 3/4	180245
C 1/8	180377					L	180281
C EOM	180432	F RU	180184			L FFC] =	180362
④ C	184345	F 5L	180226	I TAB	180178	L ↘	180385
c	184677	F 1/4	180241	I 8	180220	L FF \	180431
C ETX	184867	F ¶	180258	I	180262	L EA	180450
(C) NO	185145	F	180273	i TAB	184672	i -	184668
C ETX ④	185165	F I	180343	i	185065	L FMI ⊥	184710
C *	185212	F RU	180371	i G	185188	L DEL	184713

- ① Red Body - White Characters  
 ② Gray Body-White Lower Case, Yellow Upper Case  
 ③ Gray Body-Yellow Characters  
 ④ White Body-Gray Characters  
 ⑤ Red Character  
 ⑥ Gray Body-Red&White Characters  
 All other keytops have a gray body with white characters.

FIGURE 30. KEYTOPS (Continued)



KEYTOP DESCRIPTION	PART NO.	KEYTOP DESCRIPTION	PART NO.	KEYTOP DESCRIPTION	PART NO.	KEYTOP DESCRIPTION	PART NO.
L S	184732	N IV	184708	P ↖	184821	S X-OFF	180182
L '	184744	N )	184711	P →	184834	S ▽	180224
L I I FO	184802	N ⑆	184738	P ↗	184865	S BELL	180235
L I	184804	N	184866	P ↘	184872	S	185282
L V	184806	N :	184891	P ⋮	184887	S R-C	180360
I ~	184835	N BLK	185092	P )	185125	S STOP	180423
L ⑆	184873	N ^	185132	P ←	185140	S RM	180446
L &	184889	N CALL	185296	P ⑆	185265	S DC-2	180458
I	185064			P DLE	180282	② S X-OFF	183892
L ≠	185127			P PL-2	185298	S X-OFF	184676
L \ FF	185149	O	180169			S e	185086
L FORM ③	185164	O ←	180179			S X-OFF ③	185174
L ~ FF ③	185172	O 9	180221	Q	180171	S DC-3	185276
L FF S4 ③	185176	O ▽	180313	Q I	180213	S RPR	185301
L M J ③	185191	O →	180326	Q BR	180355	④ S	185394
L ~	185219	O <	180358	Q START	180422		
L ↘	185237	O :	180406	Q DC-1	180456		
L \ FF ③	185270	O ←	184673	② Q X-ON	183888	T TAPE	180175
L ≤ FFO	185272	O 7	184706	9	184659	T 5	180217
L \	194227	O ^	184735	Q (	184741	T	180261
		O %	184746	Q X-ON	184869	T P-O	180357
		O @	184814	Q RLF ③	185160	T PUNCH	180426
M	180196	Ø ←	184860	Q X-ON ③	185197	T TAPE	184667
M .	180238	O -	184864	C ADM ③	185198	T ?	184743
M <	180316	O +	184886	Q >	185215	T f	185087
M ◇	180330	O ⊐	185089	Q DC-1	185274	T PR ③	185162
M ?	180365	O S7 ③	185177	Q 7A	185299	T TAPE ③	185168
M J	180384	O Δ ③	185189			T BR ③	185202
M *	180417	O TRAN ③	185206			T NAL	185210
m J	184665	O PL-1	185257	R TAPE	180174	T →	185217
M ↗	184836			R 4	180216	T DC-4	185277
m	185079	P @	180180	R	180260	T T-FWD	185032
M I	185093	P O	180222	R P-OFF	180356	④ T	185395
M S	185099	P	180263	R PUNCH	180425		
M ,	185105	P I	180314	R SEP	180454		
		P ..	180327	R DC-2	180457	U	180177
		P >	180359	r TAPE	184666	U 7	180219
N ↓	180195	P 8	180389	R )	184742	U ERROR	180312
N ,	180237	P Δ	180407	R FS ③	185161	U C	180405
N >	180250	P -	180439	R TAPE ③	185167	u .	184670
N ?	180315	P DCO	180459	R EXPR ③	185201	U %	184726
N X	180340	P 10	184658	R ≥	185216	U NA	185147
N ▽	180364	P Σ	184707	R DC-2 ③	185275	U RPT	185204
N 7 8	180379	P √	184714	R 8A	185300	U T-REV	185303
N J	180416	P J	184728				
n ↑	184661	P ^	184805				

- ① Red Body - White Characters  
 ② Gray Body-White Lower Case, Yellow Upper Case  
 ③ Gray Body-Yellow Characters  
 ④ White Body-Gray Characters  
 ⑤ Red Character  
 ⑥ Gray Body-Red&White Characters  
 All other keytops have a gray body with white characters.

FIGURE 31. KEYTOPS (Continued)

KEYTOP DESCRIPTION	PART NO.	KEYTOP DESCRIPTION	PART NO.	KEYTOP DESCRIPTION	PART NO.	KEYTOP DESCRIPTION	PART NO.
V	180193	Y	180176	1	180160	④ 3	184336
V ;L	180235	Y 6	180218	1	180264	3	184653
V 3:8	180248	Y	184669	1	180264	3	184702
V	180276	Y DIAG	185203	1	180301	3	184737
V ;	180342	Y EM ③	185285	1	180320	3	184829
V ~	180415	Y T.STP	185307	1	180337	3 1/2	184874
V PRINT	180433			④ 1	184334	3 2	184877
V NT	180452			1	184651	3 3	185053
V	184680	Z	180190	1	184700	3	185081
V "	184712	Z °L+	180232	1	184875	3	185095
V —	184826	Z "	180246	1	184828	3	185112
V Φ	185239	Z +	180275	1	185051	3	185160
V SYN ③	185281	Z PR	180451	1	185069		
V 8B	185304	z	184671	1	185100		
		Z §	184800	1	185110	4	180163
		Z SUB ③	185279	1	185120	4	180267
W	180172	Z EOR ③	185288	1	185141	4 1/2	180287
W 2	180214	Z 1B	185308	1	185178	4	180322
W \	180403					4	180348
W LEM	180423					4	180393
w	184662	FS	184815			4	180398
W /	184740	GS	184816	2	180161	④ 4	184337
W >	184861	RS	184817	2	180265	4	184654
W DSCH	185199	US	184818	2	180285	4	184703
W ETB	185278	PF	184844	2	180302	4	184721
W SOR	185287	LD EM	184850	2	180321	4	184807
W ETB	185289	LR	184851	2	180344	4	184830
W EC7	185290	VR	184852	2	180346	4	184838
W 2A	185305	QR	184853	④ 2	184335	4	184878
		UR	184854	2	184652	4	185054
		QL	184855	2	184701	4	185071
X	180191	QC	184856	2	184720	4	185113
X /	180233	LD EN	184857	2	184876		
X ++	180414	ENDE	185134	2	185052		
X SEP	180453	FEHLER	185135	2	185082	5	180164
x	184674	ANRUF	185136	2	185094	5	180268
X ↑	184733	④ YES	185392	2	185111	5	180288
X ③	184747	④ NO	185393			5	180304
X ?	184825					5	180323
X Ø	185218			3	180162	5	180338
X X	185224			3	180266	5	180349
X CAN ③	185280			3	180286	5	180399
X 2B	185306			3	180303	④ 5	184338
④ X	185396			3	180334	5	184655
				3	180347	5	184722
				3	180397	5	184808

- ① Red Body - White Characters  
 ② Gray Body-White Lower Case, Yellow Upper Case  
 ③ Gray Body-Yellow Characters  
 ④ White Body-Gray Characters  
 ⑤ Red Character  
 ⑥ Gray Body-Red&White Characters  
 All other keytops have a gray body with white characters.

FIGURE 32. KEYTOPS (Continued)

KEYTOP DESCRIPTION	PART NO.	KEYTOP DESCRIPTION	PART NO.	KEYTOP DESCRIPTION	PART NO.	KEYTOP DESCRIPTION	PART NO.
5 ~	184831	7 7	185116	10	185075	,	180418
5 —	184879	7 &	185122	④ 10	185391	.	180419
5 5.	185055	7 ∇	185138	11	185076	/	180420
5	185088			12	185077	— @	180421
5 v	185096			13	185084	*	180436
5 \$	185114	8 (	180167	14 q	185083	+	180438
		8	180271	15 r	185067	X :	184656
		8 -	180291	16 <u>θ</u>	185068	= =	184657
6 &	180165	8 ]	180307	17	185061	/ 10	184709
6	180269	8 ~	180352	18	185063	&	184716
6 3/4	180289	④ 8	184341	19	185070	>	184717
6 ←	180305	8 ⊕	184811			<	184718
6 FORM	180345	8 (	184882			r E	184736
6 ^	180350	8 5/8	184897	— =	180170	- ^	184739
6 <	180400	8 ←	185057	. <	180197	=	184749
④ 6	184339	8	185074	. >	180198	↓ +	184813
6 ÷	184705	8 8	185117	; +	180199	^	184822
6 =	184723	8 x	185123	/ ?	180200	/ ↓	184837
6 !	184809	8	185185	: *	180205	~	184841
6 ≥	184832			\$ !	180283	- +	184843
6 {	184880			; :	180294	: :	184845
6 6.	185056	9 )	180168	) (	180295	. /	184884
6	185072	9	180272	. ,	180296	÷ /	184885
6 ≥	185097	9 &	180292	. .	180297	≠ →	184890
6 6	185115	9 (	180308	. .	180298	— <	184892
6 ?	185121	9 ∇	180375	. s	180300	∩ >	184893
6 Δ	185139	④ 9	184342	^ v	180310	[ =	184894
		9 →	184812	— *	180311	/ ■	184895
		9 )	184883	. ↑	180317	— 7/8	184899
7 /	180166	9 3/4	184898	. ↓	180318	& (oversize)	184900
7	180270	9 A	185058	* :	180324	— d	185060
7 7/8	180290	9	185066	— ☆	180325	g	185062
7 [	180306	9 9	185118	~ ^	180328	○ c	185085
/ ≥	180339	90	185186	// ,	180331	≡ ?	185098
7 v	180351			/ .	180332	&	185101
7 BELL	180395			*	180335	%	185102
7 ✓	180401	0 ?	180293	—	180336	- -	185103
④ 7	184340	0 >	180309	( [	180353	/ :	185104
7 \	184724	∅	180374	) ]	180354	5 =	185108
7 P	184810	∅ <	180376	+ -	180363	& *	185109
7 "	184820	∅ 0	185119	. ;	180366	/ x	185124
7 ≡	184833	0	185187	. :	180367	. >	185128
7 /	184863	○ ←	184839	* /	180368	. <	185129
7 ]	184881	□	184840	∕	180408	≥ ≤	185130
7 1 2	184896	10 /	180319	+	180412	[	185131
z	185073			\$	180413	....	185133

- ① Red Body - White Characters  
 ② Gray Body-White Lower Case, Yellow Upper Case  
 ③ Gray Body-Yellow Characters  
 ④ White Body-Gray Characters  
 ⑤ Red Character  
 ⑥ Gray Body-Red&White Characters  
 All other keytops have a gray body with white characters.

FIGURE 33. KEYTOPS (Continued)

KEYTOP DESCRIPTION	PART NO.	KEYTOP DESCRIPTION	PART NO.
<E	185137		
" 2 ①	185179		
S 4 ②	185181		
? 5 ③	185182		
= 6 ④	185183		
v 7 ⑤	185184		
⑥	185192		
⑦	185193		
⑧	185196		
(	185220		
)	185221		
⊖	185225		
;	185226		
-	185229		
+	185244		
--	185245		
∩	185246		
△	185247		
⊞	185248		
⊞	185249		
?	185260		
□	185261		
:	185262		
: □	185263		
· §	185264		
/ *	185266		
% +	185267		
■	185269		

- ① Red Body - White Characters
  - ② Gray Body-White Lower Case, Yellow Upper Case
  - ③ Gray Body-Yellow Characters
  - ④ White Body-Gray Characters
  - ⑤ Red Character
  - ⑥ Gray Body-Red&White Characters
- All other keytops have a gray body with white characters.

FIGURE 34. KEYTOPS (Continued)

## NUMERICAL INDEX

Part Number	Description and Page Number	Part Number	Description and Page Number	Part Number	Description and Page Number
247M	Coil, Magnet 20	41663	Washer, Flat 19	93118	Lockwasher 4
274M	Coil, Magnet 19	41732	Plate, Clamp 9,10,16	93507	Screw, 4-40 x 3/4 Hex 16
1020	Screw, 6-40 x 1/4 Hex 15	42823	Washer, Flat 14	95841	Screw, 10-32 x 3/8 Fil 25
1047	Screw, 6-40 Shoulder 6	42827	Screw, 3-48 x 1/4 Fil 3, 4,25	96646	Screw, 6-40 x 1-3/64 Hex 7
1118	Screw, 6-40 Shoulder 23, 25	43954	Bell 20	97266	Plate, Clamp 17
1164	Screw, 2-56 x 3/56 Fil 16	47024	Washer, Flat 19	98869	Spacer 8
1178	Screw, 2-56 x 7/16 Fil 12	49420	Spring 6,7,9,10	99803	Insulator, .094" Thk 7
1210	Screw, 2-56 x 5/8 Fil 4, 17	55219	Screw, 8-32 x 3/8 Fil 20	100149	Stud 6
1256	Setscrew, 6-40 7	55669	Spring 4	100826	Screw, 4-40 x 3/16 Rd 20
1257	Screw, 10-32 x 1-1/8 Fil 5	60669	Spring 19	102057	Screw, 4-40 Shoulder 4
1293	Screw, 4-40 x 1/8 Fil 18	71073	Washer, Flat 12,16,17	104451	Lockwasher 19
2191	Lockwasher 3,4,5,6,7,8,9, 10,12,13,15,16,17,18,19, 20,21,23,24,25	71999	Spring, Motor Thrust 21	104564	Washer, Flat 3
2263	Nut, 8-32 Hex 21	74728	Terminal, Contact 17	104710	Ball, Bearing 12
2415	Spring 9,23	74755	Washer, Felt 13	104827	Bearing, Ball 20
2422	Lockwasher 4	74805	Screw, 10-32 x 3/4 Hex 13,25	108370	Washer, Felt 15
2449	Lockwasher 20,21	74962	Spring 7	110434	Screw, 4-40 x 3/16 Fil 20,23
2669	Lockwasher 3,4,5,13,19, 20,25	76081	Washer, Flat 9,10	110435	Nut, 4-40 Hex 20
3438	Washer, Flat 4,19,20, 25	76099	Washer, Flat 13	110743	Lockwasher 10,12 to 19, 23
3595	Nut, 1/4-32 Hex 20	76422	Spring 19	111017	Screw, 6-40 x 5/16 Fil 3, 4,19,20,25
3598	Nut, 6-40 Hex 3,5,6,7,8, 10,12,13,15,16,17,20,21, 23,25	77039	Bushing, Insulating 9,10	111427	Washer, Flat 5
3599	Nut, 4-40 Hex 4,7,9,10 12,15,16,18,19	80478	Post, Spring 10	111767	Washer, Flat 16,20
3606	Nut, 6-40 Hex 16	80581	Spring 15	112626	Nut, 10-32 Hex 13,25
3608	Spring 9	81726	Terminal 9,10	112627	Nut, 2-56 Hex 12
3640	Lockwasher 4,9,10,12,18, 19,20,21	82249	Washer, Flat 10	112630	Spring 4
3646	Lockwasher 20	82547	Insulator, .094" Thk 9, 10,16,17	115122	Washer, Felt 13,16,17
3870	Spring 4,13	82548	Insulator, .062" Thk 9, 10,16,17	117416	Post 13
4702	Spring 13	82999	Spring 10	117535	Washer, Flat 5,25
4703	Spring 20	83877	Spring 10	117608	Nut, Speed 8
6345	Nut, 6-32 Hex 8,19	85976	Washer, Flat 12	119648	Ring, Retaining 15
6968	Washer, Flat 24	86283	Spring 9,10,12	119649	Ring, Retaining 7,16,17
6970	Nut, 3/8-32 Hex 5,25	86304	Spring 18	119651	Ring, Retaining 4,8,15, 16,24
7002	Washer, Flat 3,4,7,8,9, 12,13,16,18,19,20,22,23, 25	86742	Nut, 4-40 Hex 16	119652	Ring, Retaining 13,19,24
7603	Spring 16	86835	Spring 20	119653	Ring, Retaining 6,7
8330	Washer, Flat 5,8,9,19,24	86959	Bushing, Insulating 16	119654	Ring, Retaining 9,10
8449	Spacer, .094" Thk 16	88857	Washer, Spring 5	119655	Ring, Retaining 20,24
35826	Washer, Flat 3,5,19	89486	Stiffener 16	120489	Spacer, .052" Thk 15
41382	Spring 10,17	90054	Spring 16	120824	Washer, Felt 14
		90391	Washer, Felt 17	120870	Wick, Felt 15
		90615	Spring 23	121100	Spring 10
		90679	Washer, Felt 16	121242	Clamp, 1/8 ID Cable 26
		90790	Washer, Flat 24	121243	Clamp, 3/26 ID Cable 26
		90791	Lockwasher 18	121244	Clamp, 1/4 ID Cable 26
		91026	Screw, 4-40 Shoulder 10	121245	Clamp, 5/16 ID Cable 26
		91228	Strap, 2-1/2" Braided 20	121246	Clamp, 3/8 ID Cable 26
		91229	Strap, 2" Braided 20		
		93117	Lockwasher 12,16,17		

## NUMERICAL INDEX (Continued)

Part Number	Description and Page Number	Part Number	Description and Page Number	Part Number	Description and Page Number
121247	Clamp, 7/16 ID Cable 26	145367	Shaft, Drive 24	151346	Screw, 6-40 x 3/8 Fil 20, 21,24,25
121248	Clamp, 1/2 ID Cable 26	145370	Gear, 42T 24	151352	Spring, Flat 4
121249	Clamp, 5/8 ID Cable 26	145372	Shaft 24	151354	Screw, 2-56 x 15/32 Fil 4
121250	Clamp, 3/4 ID Cable 26	145375	Gear, 63T 24	151415	Block, Terminal 3,4,20, 25
121251	Clamp, 1 ID Cable 26	145376	Gear, 48T 24	151416	Nut, 6-40 Hex 3,4,20,25
121473	Post 12	145381	Washer, Thrust 24	151442	Screw, 6-40 x 1/2 Hex 5, 13,22,25
122201	Bearing, Ball 21	145383	Key 24	151540	Lampholder 20
122211	Washer, Pull 21	145384	Pin, Guide 24	151564	Bracket 20
122220	Oiler, Ball 21	145385	Spring, Compression 24	151565	Bushing, Shoulder 20
122229	Bolt, 8-32 x 4-11/16 Fil 21	145386	Sleeve 24	151567	Armature w/Clapper 20
122245	Capacitor, 43 to 48 MFD 21	145389	Shaft, Idler 24	151574	Grommet, Rubber 20
122249	Switch, Thermostatic 21	145390	Pinion, 25T 24	151577	Screw, 6-40 Shoulder 20
122251	Stator, Motor 21	148128	Washer, Flat 12	151579	Plate, Retaining 20
122252	Shield Assembly, End 21	150013	Disc, Adjusting 14	151603	Spacer 19
123769	Fan, Motor 21	150026	Lever, Shoe Release 14	151610	Washer, Flat 24
124313	Magnet Assembly 23	150029	Wick, Felt 14	151616	Screw, No. 2 Self-Tapping 20
125011	Washer, Flat 3,4,9,10, 12,13,17	150040	Screw, 6-40 x 5/8 Fil 21	151618	Screw, 6-40 x 7/16 Fil 8
125015	Washer, Flat 5,8,12,16, 20	150043	Shoe, Secondary Clutch 14	151620	Strap, Motor Mounting 21
125126	Screw, 2-56 x 9/32 Fil 18	150044	Shoe, Primary Clutch 14	151621	Screw, 6-32 x 3/4 Rd 21
125154	Screw, 3-48 Shoulder 10	150241	Spring 14	151622	Screw, 6-32 x Sq 21
125181	Screw, 2-56 x 3/8 Fil 4	150873	Collar 21	151630	Screw, 6-40 x 1/4 Hex 3, 4,5,8,9,10,19,20,24,25
125231	Nut, 10-32 Hex 20	150923	Washer, Felt 15,16	151631	Screw, 6-40 x 5/16 Hex 3 4,5,8,10,12,13,20,23,24
125250	Spring 15	150966	Insulator, Terminal Block 3,4,20,25	151632	Screw, 6-40 x 3/8 Hex 3, 4,5,7,8,10,18,19,20,23
125253	Spring 9,10	150990	Washer, Felt 16	151637	Screw, 4-40 x 1/4 Fil 4, 10,21
128874	Rotor, Motor 21	150991	Washer, Felt 9,10,13	151658	Screw, 6-40 x 5/16 Fil 20,24
139548	Bushing 3	151003	Keylever 27	151659	Screw, 6-40 x 1/2 Fil 8
139555	Spring 6	151004	Keylever 27	151678	Screw, 1/4-32 Pilot 3
142159	Bulb, 6 V Lamp 26	151005	Keylever 27	151685	Screw, 4-40 x 5/16 Fil 19
142867	Yoke 23	151006	Keylever 27	151688	Screw, 4-40 x 5/8 Fil 9, 10
142998	Screw, 6-40 x 3/8 Flat 23	151036	Screw, 4-40 Shoulder 16	151692	Screw, 6-40 x 3/16 Fil 6
144759	Spacer, .187" Thk 5	151059	Stud 7	151721	Screw, 6-40 x 3/4 Hex 21
144760	Spacer, .400" Thk 5	151080	Washer, Flat 12	151722	Screw, 6-40 x 3/16 Hex 3, 4,7,9,10,15,25
144761	Shaft 5	151113	Strip, Mounting 3,4	151723	Screw, 10-32 x 3/8 Hex 4,5,25
144763	Plate, Nut 4,25	151118	Plate, Spacing 3,4	151724	Screw, 10-32 x 5/8 Hex 5
144767	Plate w/Bracket, Bearing 5	151146	Strap, Mounting 3,4	151737	Screw, 4-40 x 11/64 Hex 14
144769	Button, Pivot 5,25	151152	Screw, 4-40 x 3/16 Hex 9, 10,12,13,18	151827	Strap, Terminal 3,4
144770	Gear Assembly, Intermediate 2,5	151153	Bearing, Sleeve 14	151843	Screw, 6-40 Adjusting 12
145313	Washer, Felt 24	151182	Washer, Insulating 18		
145321	Tie, Cable 19	151223	Screw, 4-40 Spl 8		
145364	Bracket w/Bearing 24,25	151224	Screw, 6-40 Pilot 8		
145365	Pinion, 20T 24	151233	Spacer, .065" Thk 4		
145366	Gear, 56T 24	151245	Washer, Felt 24		
		151249	Keytop 27		
		151250	Keytop 27		
		151254	Keytop 27		
		151329	Switch, Sensitive 26		
		151335	Stud 3,4,20,25		

## NUMERICAL INDEX (Continued)

Part Number	Description and Page Number	Part Number	Description and Page Number	Part Number	Description and Page Number
151922	Clamp 21	154046	Stud 13	154227	Bracket, Support 7
151923	Relay, Motor Starting 21	154047	Post, Spring 15	154236	Lever, Latch 13
151924	Insulator, .031" Thk 21	154051	Screw, 6-40 Shoulder 16	154238	Extension 12
151925	Clamp 21	154053	Bail, Clutch Trip 13	154239	Extension w/Post 12
151939	Grommet, Rubber 20	154056	Bracket, Contact Box 18	154240	Bail, Codebar 16
151982	Lamp, 6V Incandescent 20	154059	Bracket, Function Bail 6	154241	Stud 16
152045	Guard, Gear 3	154066	Lever, LOC-LF 6,7	154386	Plate, Adjusting 16
152129	Spring 19	154071	Screw, 1/4-32 Pilot 9,10	154694	Disc, Clutch Cam 14
152297	Washer, Bearing 21	154072	Bracket, Stop 9,10	155046	Screw, 4-40 x 15/32 Hex 17
152425	Post, Spring 19	154076	Plate, Nut 3	155750	Sleeve, 3/32 ID x 1/2" Lg Insulating 26
152426	Nut, 6-40 Self-Locking 19	154079	Stud 16	155751	Sleeve, 1/8 ID x 1" Lg Insulating 26
152461	Bracket 20,23	154080	Lock, Wedge 12	155752	Sleeve 5/64 ID x 1/2" Lg Insulating 26
152462	Latch, Right 20	154083	Spacer, Cam 14	155753	Sleeve, 1/8 ID x 1/2" Lg Insulating 23,26
152463	Latch, Left 20	154084	Bearing, Needle 16	155754	Sleeve, 1/16 ID x 1/2" Lg Insulating 26
152464	Insulator, .062" Thk 20	154087	Plate, Nut 3	155755	Sleeve, 11/64 ID x 5/8" Lg Insulating 19,26
152467	Connector, 20 Pt Plug 20	154088	Plate, Nut 4	155954	Switch, Sensitive 4
152818	Lever, Left Detent 7	154089	Post, Spring 16	155994	Insulator, .015" Thk 4
152893	Screw, 4-40 x 1/4 Hex 12	154091	Guide, Non Repeat Lever 16	156503	Wick, Felt 14
153030	Mount, Vibration 21	154092	Shaft 6,7	156509	Washer, Flat 15
153049	Washer, Insulating 21	154094	Clamp 13	156574	Post, Spring 12
153109	Lever, Function 6	154095	Eccentric, Contact Box 18	156630	Washer, Felt 15
153280	Keytop 27	154096	Bushing, Eccentric 13	156632	Screw, 6-40 x 13/32 Hex 5
153304	Bushing, Shoulder 25	154099	Bail, LOC-CR Function 6,7	156644	Link, Drive 18
153441	Screw, 10-32 x 7/16 Hex 3,19,20	154101	Plate, Rear 13	156663	Bushing, Insulating 18
153538	Screw, 6-40 x 6/16 Hex 19	154105	Post, Transfer Bail 15	156740	Screw, 6-40 x 7/32 Hex 12,19,23
153631	Network, Spark Suppression 19	154109	Plunger 4	156936	Screw, 1/4-32 x 5/16 Hex 21
153817	Screw, 4-40 x 3/8 Hex 12,18	154115	Plate, Guide 4	158163	Switch, Sensitive 4,26
153819	Lockwasher, 3,4,25	154120	Lever, Codebar 9,10	158164	Lever w/Hub 4
153839	Screw, 6-40 x 5/8 Hex 19	154125	Spring 9,10	158231	Contact Assembly 7,26
153841	Screw, 6-40 x 9/16 Hex 3, 8,13	154126	Bracket 7	158254	Bail Assembly, Function 2,6
154000	Base 3,4,6,7,22	154127	Nut, 6-40 Hex 16	158268	Latch w/Hub 16
154008	Guide, Codebar 9	154130	Box, Contact 18	158275	Plate, Clamp 7
154009	Plate, Front 15	154131	Cover, Contact 18	158277	Screw, 3-48 x 1 Rd 7
154010	Bail, Transfer 15	154138	Washer, Felt 14	158745	Clamp, Bearing 5,20,24
154013	Bracket, Spring 9,10	154156	Grommet, Rubber 26	158816	Spring, Contact 9,10
154015	Post 16	154164	Frame Assembly 13	158828	Bushing, Mounting 5
154019	Follower, Eccentric 14	154166	Suppressor, Arc 18	158907	Spring 15
154021	Link 8	154167	Detent Assembly 15	159284	Pinion, 20T 5
154027	Bellcrank 16	154173	Plate 26	159285	Gear, 84T 5
154029	Wick, Felt 14	154189	Insulator 18	159287	Retainer, Pinion 5,20,24
154030	Shaft, Signal Generator 14	154191	Spring 10,16		
154032	Sleeve, Gear 14	154193	Plate 7		
154033	Lever, Clutch Latch 13	154199	Shim, .005" Thk 4		
154034	Lever, Clutch Stop 13	154201	Shim, .014" Thk 4		
154036	Plate, Detent 15	154208	Bracket, Switch 4		
		154215	Spring 16		
		154217	Wick, Feather 15		

## NUMERICAL INDEX (Continued)

Part Number	Description and Page Number	Part Number	Description and Page Number	Part Number	Description and Page Number
159327	Washer, Flat 16	170409	Bail, Spacebar 8	179372	Shield, Light 20
159328	Bearing Assembly 16	170410	Plate, Nut 4	179639	Contact Assembly 18
159334	Washer, Insulating 10,16	170414	Lever, Function 9,10	180044	Terminal, Tab Type 26
159341	Bearing, Ball 5,24	170418	Bracket 4	180045	Terminal, Tab Type 26
160087	Post, Spring 23	171688	Bushing, .265" Thk 17	180160	Keytop 30
160090	Lever, Transfer 15	173096	Stud, Eccentric 16	180161	Keytop 30
160593	Terminal 16	173715	Terminal, Plug Type 26	180162	Keytop 30
161295	Gearset, 100 WPM 5	173974	Screw, 10-32 x 5/16 Hex 19	180163	Keytop 30
161301	Post 5,20,24	174250	Pin, Roll 5,24	180164	Keytop 30
161346	Washer, Felt 15	176339	Post, Stop 16	180165	Keytop 31
162333	Stud, Locating 6,7	176352	Box Assembly, Contact 2, 18	180166	Keytop 31
162659	Retainer 24	176354	Sleeve 15	180167	Keytop 31
162883	Cover, Insulating 7	176663	Link 4	180168	Keytop 31
163440	Gear, 48T 5	176752	Ring, Retaining 19	180169	Keytop 29
164399	Cable w/Terminals 20	176900	Base 20	180170	Keytop 31
164419	Plate, Nut 19	176908	Shaft 20	180171	Keytop 29
165261	Screw, 4-40 x 3/8 Oval 8	176923	Plate, Vibration 20	180172	Keytop 30
170172	Bracket 4	176924	Plate, Nut 20	180173	Keytop 28
170173	Lever w/Hub 7	176929	Retainer, Belt 20	180174	Keytop 29
170324	Bracket, Front 9,23	176932	Plate, Upper Bearing 20	180175	Keytop 29
170332	Bail Assembly, Universal 2,12	176933	Stud 20	180176	Keytop 30
170340	Bail Assembly, Function 2,7	176936	Bracket, Left 20	180177	Keytop 29
170361	Bar, Clutch Trip 9,10,11	176937	Bracket, Right 20	180178	Keytop 28
170363	Bracket, Left 9,10	176939	Gear Assembly, Intermediate 20	180179	Keytop 29
170364	Bracket, Right 9,10	176940	Plate, Nut 20	180180	Keytop 29
170365	Guide, Codelever 9,10	176941	Plate, Nut 20	180181	Keytop 28
170368	Shaft 9,10	176944	Plate, Nut 20	180182	Keytop 29
170369	Bracket, Support 9	176945	Bracket, Connector 20	180183	Keytop 28
170370	Lever, Function 9,10	176947	Plate w/Pads 21	180184	Keytop 28
170371	Lever, Function 9,10	176948	Bracket w/Cradle, Motor 21	180185	Keytop 28
170372	Bail, Universal 12	178142	Camsleeve 14	180186	Keytop 28
170373	Blade, Rear 12	178144	Contact Assembly 9,10	180187	Keytop 28
170374	Blade, Front 12	178145	Bracket, Switch 9,10	180188	Keytop 28
170375	Lever, Auxiliary 9,10	178146	Guard 9,10	180189	Keytop 28
170379	Retainer, Ball 12	178147	Spring, Contact 9,10	180190	Keytop 30
170380	Retainer, Wedge 12	178500	Motor, 115V AC Synchronous 2,21	180191	Keytop 30
170385	Frame w/Bushing 13	178536	Window, Plastic 8	180192	Keytop 28
170386	Guide, Transfer Lever 15	178537	Tissue 8	180193	Keytop 30
170388	Guidepost 15	178538	Label, Blank 8	180194	Keytop 28
170390	Bail, Locking 15	178539	Paper, White Carbon 8	180195	Keytop 29
170391	Guide, Transfer Lever 15	178540	Label, Instruction 8	180196	Keytop 29
170392	Lever, Non-Repeat 16	178541	Label Set 8	180197	Keytop 31
170395	Bracket, Function Bail 7	178547	Plate, 10-32 Nut 20	180198	Keytop 31
170397	Bail, L.C.R. 7	178549	Bumper, Rubber 20	180199	Keytop 31
170398	Lever, L.L.F. 7	178714	Switch, Rocker Type 8	180200	Keytop 31
170406	Bracket, Left Space Bar 8			180201	Keytop 27
170407	Bracket, Right Space Bar 8			180202	Keytop 27
				180203	Keytop 27
				180205	Keytop 31
				180206	Keytop 27



## NUMERICAL INDEX (Continued)

Part Number	Description and Page Number	Part Number	Description and Page Number	Part Number	Description and Page Number
180207	Keytop 27	180268	Keytop 30	180338	Keytop 30
180208	Keytop 27	180269		180339	Keytop 31
180210	Keytop 27	thru		180340	Keytop 29
180211	Keytop 27	180272	Keytop 31	180341	Keytop 27
180213	Keytop 29	180273	Keytop 28	180342	Keytop 30
180214	Keytop 30	180274	Keytop 28	180343	Keytop 28
180215	Keytop 28	180275	Keytop 30	180344	Keytop 30
180216	Keytop 29	180276	Keytop 30	180345	Keytop 31
180217	Keytop 29	180277	Keytop 28	180346	
180218	Keytop 30	180278	Keytop 28	thru	
180219	Keytop 29	180280	Keytop 28	180349	Keytop 30
180220	Keytop 28	180281	Keytop 28	180350	
180221	Keytop 29	180282	Keytop 29	thru	
180222	Keytop 29	180283	Keytop 31	180354	Keytop 31
180223	Keytop 28	180284		180355	
180224	Keytop 29	thru		thru	
180226	Keytop 28	180288	Keytop 30	180359	Keytop 29
180227	Keytop 28	180289		180360	Keytop 29
180228	Keytop 28	thru		180361	Keytop 28
180229	Keytop 28	180298	Keytop 31	180362	Keytop 28
180230	Keytop 28	180299	Keytop 27	180363	Keytop 31
180231	Keytop 28	180300	Keytop 31	180364	Keytop 29
180232	Keytop 30	180301		180365	Keytop 29
180233	Keytop 30	thru		180366	Keytop 31
180234	Keytop 28	180304	Keytop 30	180367	Keytop 31
180235	Keytop 30	180305		180368	Keytop 31
180236	Keytop 28	thru		180369	
180237	Keytop 29	180311	Keytop 31	thru	
180238	Keytop 29	180312		180372	Keytop 28
180239	Keytop 29	thru		180373	Keytop 27
180240		180316	Keytop 29	180374	Keytop 31
thru		180317		180375	Keytop 31
180245	Keytop 28	thru		180376	Keytop 31
180246	Keytop 30	180319	Keytop 31	180377	Keytop 28
180247	Keytop 28	180320		180378	Keytop 28
180248	Keytop 30	thru		180379	Keytop 29
180249	Keytop 28	180323	Keytop 30	180380	Keytop 27
180250	Keytop 29	180324	Keytop 31	180381	Keytop 28
180255	Keytop 28	180325	Keytop 31	180382	Keytop 27
180257	Keytop 27	180326	Keytop 29	180384	Keytop 29
180258	Keytop 28	180327	Keytop 29	180385	
180259	Keytop 28	180328	Keytop 31	thru	
180260	Keytop 29	180330	Keytop 29	180388	Keytop 28
180261	Keytop 29	180331	Keytop 31	180389	Keytop 29
180262	Keytop 28	180332	Keytop 31	180390	
180263	Keytop 29	180333	Keytop 28	thru	
180264	Keytop 30	180334	Keytop 30	180392	Keytop 28
180265	Keytop 30	180335	Keytop 31	180393	Keytop 30
180266	Keytop 30	180336	Keytop 31	180394	Keytop 28
180267	Keytop 30	180337	Keytop 30	180395	Keytop 31

## NUMERICAL INDEX (Continued)

Part Number	Description and Page Number	Part Number	Description and Page Number	Part Number	Description and Page Number
180396	Keytop 28	180451	Keytop 30	184347	Keytop 27
180397	Keytop 30	180452	Keytop 30	184651	
180398	Keytop 30	180453	Keytop 30	thru	
180399	Keytop 30	180454	Keytop 29	184655	Keytop 30
180400	Keytop 31	180455	Keytop 28	184656	Keytop 31
180401	Keytop 31	180456		184657	Keytop 31
180402	Keytop 27	thru		184658	Keytop 29
180403	Keytop 30	180459	Keytop 29	184659	Keytop 29
180404	Keytop 28	180675	Screw, No. 6 Self-Tapping 4	184660	Keytop 28
180405	Keytop 29	180823	Block, Contact 19	184661	Keytop 29
180406	Keytop 29	180824	Contact, Common 19	184662	Keytop 30
180407	Keytop 29	180826	Lever, Detent 19	184663	Keytop 28
180408	Keytop 31	180827	Drum, Answer Back 19	184664	Keytop 28
180409	Keytop 28	180828	Pawl, Feed 19	185665	Keytop 29
180410	Keytop 28	180842	Spacer, .050" Thk 19	184666	Keytop 29
180411	Keytop 28	180854	Brace 19	184667	Keytop 29
180412	Keytop 31	180858	Contact, Wire 19	184668	Keytop 28
180413	Keytop 31	180904	Tab, Terminal 4	184669	Keytop 30
180414	Keytop 30	180979	Brush, Carbon 19	184670	Keytop 29
180415	Keytop 30	180980	Holder, Brush 19	184671	Keytop 30
180416	Keytop 29	180987	Disc, 8 Lever 19	184672	Keytop 28
180417	Keytop 29	180992	Spring, Torsion 19	184673	Keytop 29
180418		181253	Keytop 27	184674	Keytop 30
thru		181284	Spring 14	184675	Keytop 28
180421	Keytop 31	181971	Keytop 27	184676	Keytop 29
180422	Keytop 29	182644	Terminal, Receptacle Type 26	184677	Keytop 28
180423	Keytop 30	182648	Connector, 12 Pt Receptacle Type 19	184678	Keytop 28
180424	Keytop 28	182660	Switch, Pushbutton 26	184679	Keytop 28
180425	Keytop 29	182714	Cap, White Lens 26	184680	Keytop 30
180426	Keytop 29	182726	Terminal, Receptacle Type 26	184681	Keytop 28
180427	Keytop 28	183888	Keytop 29	184682	Keytop 28
180428	Keytop 29	183889	Keytop 28	184683	Keytop 28
180429		183890	Keytop 28	184700	
thru		183891	Keytop 28	thru	
180432	Keytop 28	183892	Keytop 29	184703	Keytop 30
180433	Keytop 30	183920	Keytop 27	184705	Keytop 31
180434	Keytop 28	184334		184706	Keytop 29
180435	Keytop 28	thru		184707	Keytop 29
180436	Keytop 31	184338	Keytop 30	184708	Keytop 29
180437	Keytop 28	184339		184709	Keytop 31
180438	Keytop 31	thru		184710	Keytop 28
180439	Keytop 29	184342	Keytop 31	184711	Keytop 29
180440		184343	Keytop 28	184712	Keytop 30
thru		184344	Keytop 28	184713	Keytop 28
180444	Keytop 27	184345	Keytop 28	184714	Keytop 29
180446	Keytop 29	184346	Keytop 28	184715	Keytop 27
180447	Keytop 28			184716	
180448	Keytop 28			thru	
180449	Keytop 28			184718	Keytop 31
180450	Keytop 28			184719	Keytop 27

## NUMERICAL INDEX (Continued)

Part Number	Description and Page Number	Part Number	Description and Page Number	Part Number	Description and Page Number
184720	Keytop 30	184823	Keytop 28	184886	Keytop 29
184721	Keytop 30	184824	Keytop 28	184887	Keytop 29
184722	Keytop 30	184825	Keytop 30	184888	Keytop 28
184723	Keytop 31	184826	Keytop 30	184889	Keytop 29
184724	Keytop 31	184827	Keytop 28	184890	Keytop 31
184725	Keytop 28	184828	Keytop 30	184891	Keytop 29
184726	Keytop 29	184829	Keytop 30	184892	
184727	Keytop 28	184830	Keytop 30	thru	
184728	Keytop 29	184831		184900	Keytop 31
184729	Keytop 28	thru		185051	
184730	Keytop 28	184833	Keytop 31	thru	
184731	Keytop 28	184834	Keytop 29	185054	Keytop 30
184732	Keytop 29	184835	Keytop 29	185055	
184733	Keytop 30	184836	Keytop 29	thru	
184734	Keytop 27	184837	Keytop 31	185058	Keytop 31
184735	Keytop 29	184838	Keytop 30	185059	Keytop 28
184736	Keytop 31	184839		185060	
184737	Keytop 30	thru		thru	
184738	Keytop 29	184841	Keytop 31	185063	Keytop 31
184739	Keytop 31	184842	Keytop 27	185064	Keytop 29
184740	Keytop 30	184843	Keytop 31	185065	Keytop 28
184741		184844	Keytop 30	185066	
thru		184845	Keytop 31	thru	
184744	Keytop 29	184846		185068	Keytop 31
184745	Keytop 28	thru		185069	Keytop 30
184746	Keytop 29	184849	Keytop 27	185070	Keytop 31
184747	Keytop 30	184850		185071	Keytop 30
184748	Keytop 27	thru		185072	
184749	Keytop 31	184857	Keytop 30	thru	
184800	Keytop 30	184858	Keytop 27	185077	Keytop 31
184801	Keytop 28	184859	Keytop 27	185078	Keytop 28
184802	Keytop 29	184860	Keytop 29	185079	Keytop 29
184803	Keytop 28	184861	Keytop 30	185080	Keytop 28
184804	Keytop 29	184862	Keytop 27	185081	Keytop 30
184805	Keytop 29	184863	Keytop 31	185082	Keytop 30
184806	Keytop 29	184864	Keytop 29	185083	
184807	Keytop 30	184865	Keytop 29	thru	
184808	Keytop 30	184866	Keytop 29	185085	Keytop 31
184809	Keytop 31	184867	Keytop 28	185086	Keytop 29
184810		184868	Keytop 28	185087	Keytop 29
thru		184869	Keytop 29	185088	Keytop 31
184813	Keytop 31	184870	Keytop 28	185089	Keytop 29
184814	Keytop 29	184871	Keytop 27	185090	Keytop 28
184815		184872	Keytop 29	185091	Keytop 27
thru		184873	Keytop 29	185092	Keytop 29
184818	Keytop 30	184874		185093	Keytop 29
184819	Keytop 27	thru		185094	Keytop 30
184820	Keytop 31	184878	Keytop 30	185095	Keytop 30
184821	Keytop 29	184879		185096	
184822	Keytop 31	thru		thru	
		184885	Keytop 31	185098	Keytop 31

## NUMERICAL INDEX (Continued)

Part Number	Description and Page Number	Part Number	Description and Page Number	Part Number	Description and Page Number
185099	Keytop 29	185168	Keytop 29	185222	Keytop 27
185100	Keytop 30	185169	Keytop 28	185223	Keytop 27
185101		185170	Keytop 28	185224	Keytop 30
thru		185171	Keytop 28	185225	Keytop 32
185104	Keytop 31	185172	Keytop 29	185226	Keytop 32
185105	Keytop 29	185173	Keytop 28	185227	Keytop 27
185106	Keytop 28	185174	Keytop 29	185228	Keytop 27
185108	Keytop 31	185175	Keytop 28	185229	Keytop 32
185109	Keytop 31	185176	Keytop 29	185230	
185110		185177	Keytop 29	thru	
thru		185178	Keytop 30	185236	Keytop 28
185113	Keytop 30	185179	Keytop 32	185237	Keytop 29
185114		185180	Keytop 30	185238	Keytop 28
thru		185181		185239	Keytop 30
185119	Keytop 31	thru		185240	Keytop 28
185120	Keytop 30	185184	Keytop 32	185242	Keytop 28
185121		185185		185243	Keytop 28
thru		thru		185244	
185124	Keytop 31	185187	Keytop 31	thru	
185125	Keytop 29	185188	Keytop 28	185249	Keytop 32
185126	Keytop 28	185189	Keytop 29	185260	
185127	Keytop 29	185190	Keytop 27	thru	
185128		185191	Keytop 29	185264	Keytop 32
thru		185192	Keytop 32	185265	Keytop 29
185131	Keytop 31	185193	Keytop 32	185266	Keytop 32
185132	Keytop 29	185194	Keytop 27	185267	Keytop 32
185133	Keytop 31	185195	Keytop 27	185268	Keytop 27
185134	Keytop 30	185196	Keytop 32	185269	Keytop 32
185135	Keytop 30	185197	Keytop 29	185270	Keytop 29
185136	Keytop 30	185198	Keytop 29	185271	Keytop 28
185137	Keytop 32	185199	Keytop 30	185272	Keytop 29
185138	Keytop 31	185200	Keytop 28	185273	Keytop 28
185139	Keytop 31	185201	Keytop 29	185274	
185140	Keytop 29	185202	Keytop 29	thru	
185141	Keytop 30	185203	Keytop 30	185277	Keytop 29
185142		185204	Keytop 29	185278	
thru		185205	Keytop 28	thru	
185146	Keytop 28	185206	Keytop 29	185281	Keytop 30
185147	Keytop 29	185210	Keytop 29	185282	Keytop 29
185148	Keytop 28	185211	Keytop 27	185283	Keytop 28
185149	Keytop 29	185212	Keytop 28	185285	Keytop 30
185159	Keytop 27	185213	Keytop 28	185286	Keytop 28
185160	Keytop 29	185214	Keytop 28	185287	
185161	Keytop 29	185215	Keytop 29	thru	
185162	Keytop 29	185216	Keytop 29	185290	Keytop 30
185163	Keytop 28	185217	Keytop 29	185291	
185164	Keytop 29	185218	Keytop 30	thru	
185165	Keytop 28	185219	Keytop 29	185295	Keytop 28
185166	Keytop 28	185220	Keytop 32	185296	
185167	Keytop 29	185221	Keytop 32	thru	
				185303	Keytop 29

## NUMERICAL INDEX (Continued)

Part Number	Description and Page Number	Part Number	Description and Page Number	Part Number	Description and Page Number
185304		192458	Keylever Assembly 6	195053	Cover, Insulating 16
thru		192485	Contact Assembly 16	195186	Screw, 4-40 x 7/8 Hex 18
185308	Keytop 30	192497	Bracket 4	195432	Spring, Contact 16
185391	Keytop 31	192498	Bracket 6	195433	Spring, Contact 16
185392	Keytop 30	192501	Bail Assembly, Function 2,7	195617	Spring 19
185393	Keytop 30			195618	Jumper, 5-1/4" White-Purple 19
185394	Keytop 29	192511	Spacebar 8		
185395	Keytop 29	192521	Codebar, No. 1 9,11	195716	Plate, Identification 20
185396	Keytop 30	192522	Codebar, No. 2 9	195884**	Plate, Left 8
192013	Connector, 50 Pt Plug Type 25,26	192523	Codebar, No. 3 9,10,11	195885**	Plate, Right 8
192020	Bracket, Mounting 19	192524	Codebar, No. 4 9,10,11	195992	Belt, 83T 20
192021	Plate, Left Nut 3	192525	Codebar, No. 5 9,10,11	195993	Gear, 26T 20
192022	Gear, 90T 19	192526	Codebar, No. 6 9,10,11	195994	Pulley, 34T 20
192025	Washer, Flat 19	192527	Codebar, No. 7 9,10,11	195995	Pulley, 12T 20
192026	Hub, Gear 5	192529	Codebar, Shift 9	195997	Gear, 34T 20
192027	Spacer, Disc 19	192530	Bar, Shift Lock 9	195999	Gear, 21T 20
192028	Bushing, Shoulder 19	192531	Lever, Transfer 15	197000	Bail Assembly, Function 2,7
192029	Shaft, Main 19	192533	Plate, Rear 16,17		
192030	Bearing 19	192534	Post, Locking Bail 15	197005	Lever, Function 9,10
192031	Shaft 5	192535	Bail w/Post 9	197013	Lever, Transfer 15
192032	Plate, Right Nut 3	192537	Plate, Adjustment 9	197015	Bracket, Mounting 7
192034	Bearing, Clutch 19	192538	Plug, Button 8	197016	Insulator, .020" Thk 3
192035	Lever, Clutch Release 19	192550	Bar Assembly, Ball Lock 12	197017	Latch, Lock 10
192036	Drum, Shaft 19	192552	Channel, Bail 12	197018	Lever, Keyboard Lock 7
192037	Spring, Right Clutch 19	192553	Bracket, Left Mounting 8	197019	Box Assembly, Contact 2, 18
192038	Lever, Stop 19	192554	Bracket, Right Mounting 8,12	197040	Keytop 27
192039	Cam, Feed 19	192555	Plate, Keytop Guide 8,27	197056	Clip 15
192040	Bearing 19	192556	Frame 8	198236	Post 16,17
192041	Bracket, Feed Lever 19	192557	Grommet, Rubber 8	198237	Follower, Cam 16
192042	Shaft 19	192558	Codebar, CR 9,10,11	198501	Spring, Lock 4
192043	Bail, Feed 19	192559	Codebar, Counter 9,10,11	198530	Plate, Spring 10
192044	Screw, 4-40 Shoulder 19	192579	Bushing, Shoulder 9,10	198531	Plate, Blocking 10
192045	Spring, Feed Pawl 19	192589	Post, Stop 16	198533	Plate, Blocking 10
192046	Gear Assembly, Intermediate 2,5	192595	Post, Eccentric 16	198534	Arm w/Roller 10
192047	Bracket, Yoke 19	192596	Follower, Cam 16	198535	Post 10
192048	Armature, Clutch Trip 19	192597	Bracket 16	198536	Lockbar, Shift 10,11
192049	Relay 19	192630	Bracket 3,4	198537	Lockbar, Control 10,11
192050	Screw, 10-32 Shoulder 19	193723	Clip, Spring 20	198538	Codebar, No. 51 10,11
192052	Ring 19	194226	Keytop 27	198539	Bail, Blocking 10
192176	Terminal, Plug Type 26	194227	Keytop 29	198540	Bail, Blocking 10
192189	Bracket, Connector 19	194816	Spring 19	198541	Screw, 6-40 Shoulder 10
192207	Pin, Roll 19	194955	Lever w/Hub 7	198542	Codebar, No. 81 10,11
192225	Contact Assembly 19	194957	Cable Assembly 7	198543	Codebar, No. 8 10,11
192297	Latch 15	194982	Clip, Connector 25,26	198544	Guide, Left Codebar 10
192331	Plate 3	194994	Feed-Out Assembly 2,7	198545	Guide, Right Codebar 10
192452	Bracket 3	195050	Bracket 9,10	198547	Codebar, No. 1A 10,11
192453	Plate, Connector 3	195051	Plate 16	198548	Codebar, No. 2A 10,11
192457	Keylever Assembly 6	195052	Plate, Nut 16	304286	Bracket, Switch 22
				304287**	Cover, Keyboard 22

\*\*Refer to page 1 for finish suffix

## NUMERICAL INDEX (Continued)

Part Number	Description and Page Number	Part Number	Description and Page Number	Part Number	Description and Page Number
304862	Bracket 23	312994	Modification Kit 12,27	320476	Codebar 11
304864	Armature 23	312995	Bar, Retainer 12	320477	Codebar 11
305469	Bail Assembly, Function 2,7	315860	Gear, 117T 5	320478	Codebar 11
305736	Gear, 63T 5	315861	Pinion, 19T 5	320479	Codebar 11
305764	Guard, Gear 19	315865	Gearset, 100 WPM 5	320480	Codebar 11
306607	Pawl, Latch 23	315869	Modification Kit 2,23	321727	Guide 12
307080	Sleeve 14	315870	Plate, Mounting 23	321918	Gasket 17
308429	Codebar, No. 3A 11	315871	Bracket, Mounting 23	321919	Cover 17
308430	Codebar, No. 6A 11	315872	Plate, Adjusting 23	321920	Spring, Contact 17
308431	Codebar, No. 7A 11	319381	Gear, 32T 24	321921	Spring, Contact 17
309507	Contact 12	319382	Gear, 72T 24	321922	Plunger 17
309508	Bracket, Left 12	319384	Bushing 25	324009	Bracket 17
309509	Bracket, Right 12	319385	Modification Kit 2,24,25	324010	Contact Assembly 17
310630	Bushing, Eccentric 19	319386	Bracket 25	324011	Follower, Cam 17
311201		319387	Bracket 25	324012	Stud 16,17
thru		319388	Lever 25	324013	Post 16,17
311206	Codebar 11	319389	Link, Gear Shift 24,25	324129	Spring 10
311208	Codebar 11	319390	Bracket, Connector 25	324532	Screw, 4-40 x 3/16 Hex 10
311209	Codebar 11	320410	Terminal, Spade Type 7,26	324580	Codebar 11
311211	Codebar 11	320416	Terminal, Ring Type 26	327450	Label 18
311285	Screw, 6-40 Shoulder 10	320418	Terminal, Ring Type 20,26	329089	Spring 9,10
311488	Gearset 5	320420	Terminal, Ring Type 20	330714	Insulator 12
311490	Pinion, 20T 5	320422	Terminal, Ring Type 20	330963	Keylever 27
311491	Gear, 126T 5	320471	Codebar 11	330964	Keylever 27
311531	Codebar 11	320472	Codebar 11	330965	Keylever 27
311533	Codebar 11	320473	Codebar 11	330966	Keylever 27
311741	Bracket, Spacebar 8	320474	Codebar 11	340015	Bracket, Feed Lever 19
		320475	Codebar 11		

35 ELECTRICAL SERVICE UNIT (LESU)  
FOR KSR AND RO SETS

PARTS

FIGURE	CONTENTS	PAGE
1	Container and Associated Parts	2
2	193410, 193437, and 305406 Mounting Plate Assemblies	3
3	305417 Main Terminal Board Assembly	4
4	305440 and 323088 Relay Plate Assemblies	5
5	344252 Relay Plate Assembly	6
6	336103 Buzzer Alarm Assembly	6
7	199360 and 304922 Power Distribution Assemblies	7
8	311076 Power Distribution Assembly	8
9	319257 and 336108 Power Distribution Assemblies	9
10	323056 Power Distribution Assembly	10
11	165699 Power Distribution Assembly	11
12	165708 Motor Control Relay Assembly	11
13	323580 Interface Logic Assembly	12
14	197041 and 323013 (ROTR) Power Distribution Assemblies	13
15	199350, 311484, and 320452 Copylight Transformer Assemblies	14
16	193451 Signal Bell Assembly	15
17	165736 and 198209 Signal Regenerator Assemblies	15
18	305446 Signal Regenerator Assembly	16
19	193485, 197053, and 312351 Constant Current Selector Magnet Driver Assemblies	17
20	305447 Selector Magnet Driver Assembly With Break Detector	18
21	197035 Electrical Motor Control Assembly	19
22	305061 (60 Hertz), 310707 (50/60 Hertz) Rectifier and Cable Assemblies	20
23	323050 Rectifier Assembly	21
24	305093 Terminal Plate Assembly	22
25	304673 and 305421 Relay Rack Assemblies and Terminal Strips	22
26	Cable Components	23
	Numerical Index	24

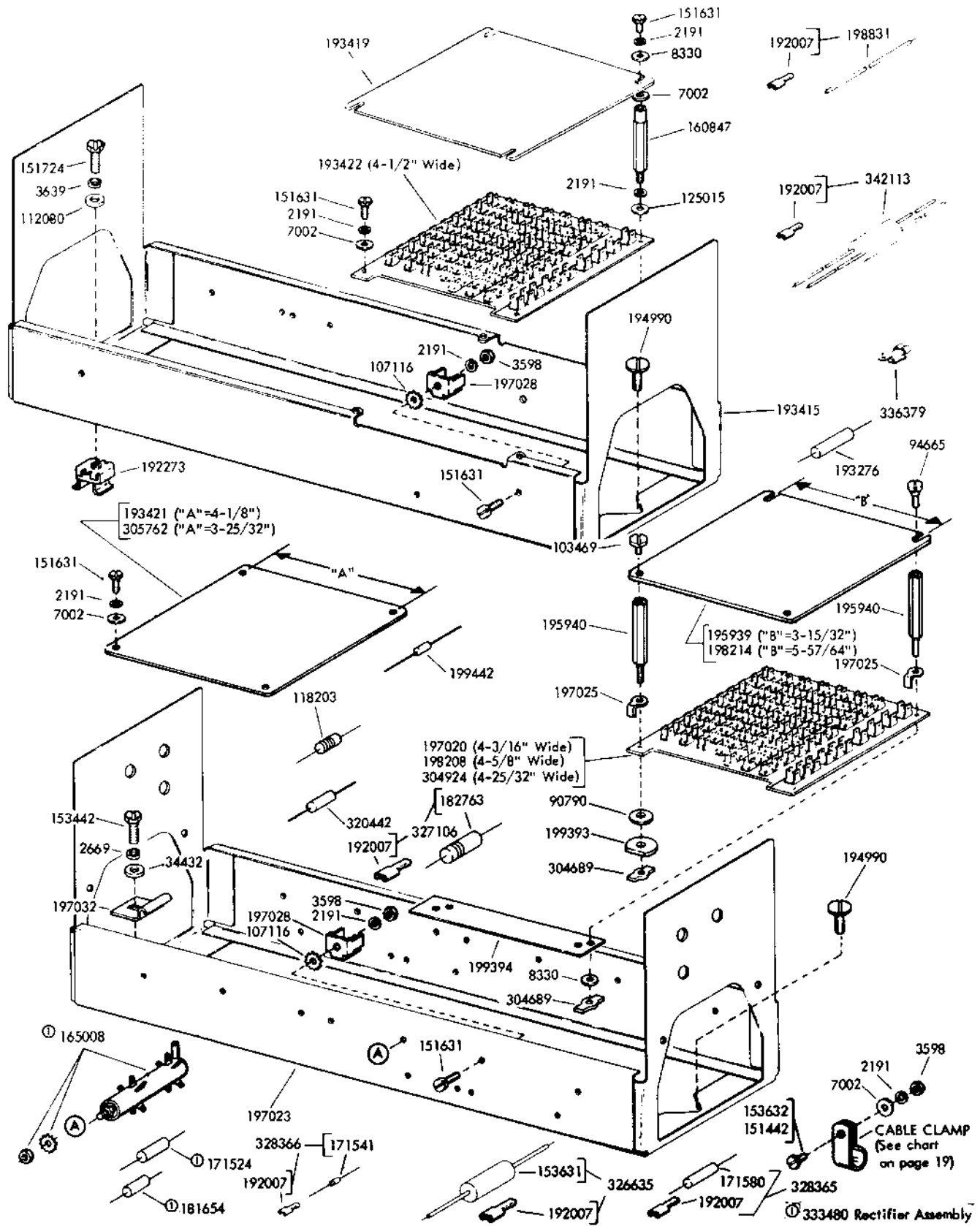

FIGURE 1. CONTAINER AND ASSOCIATED PARTS



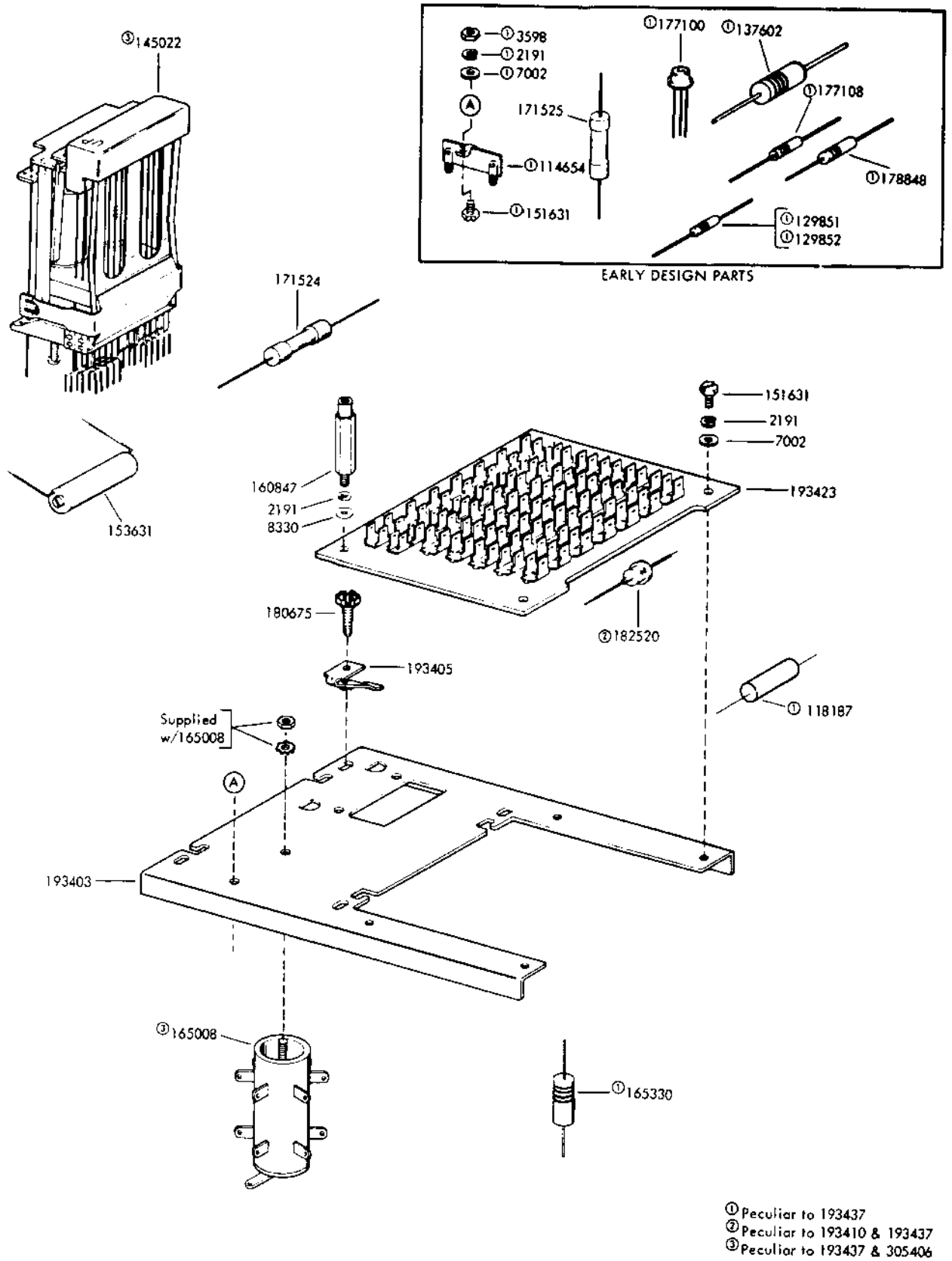
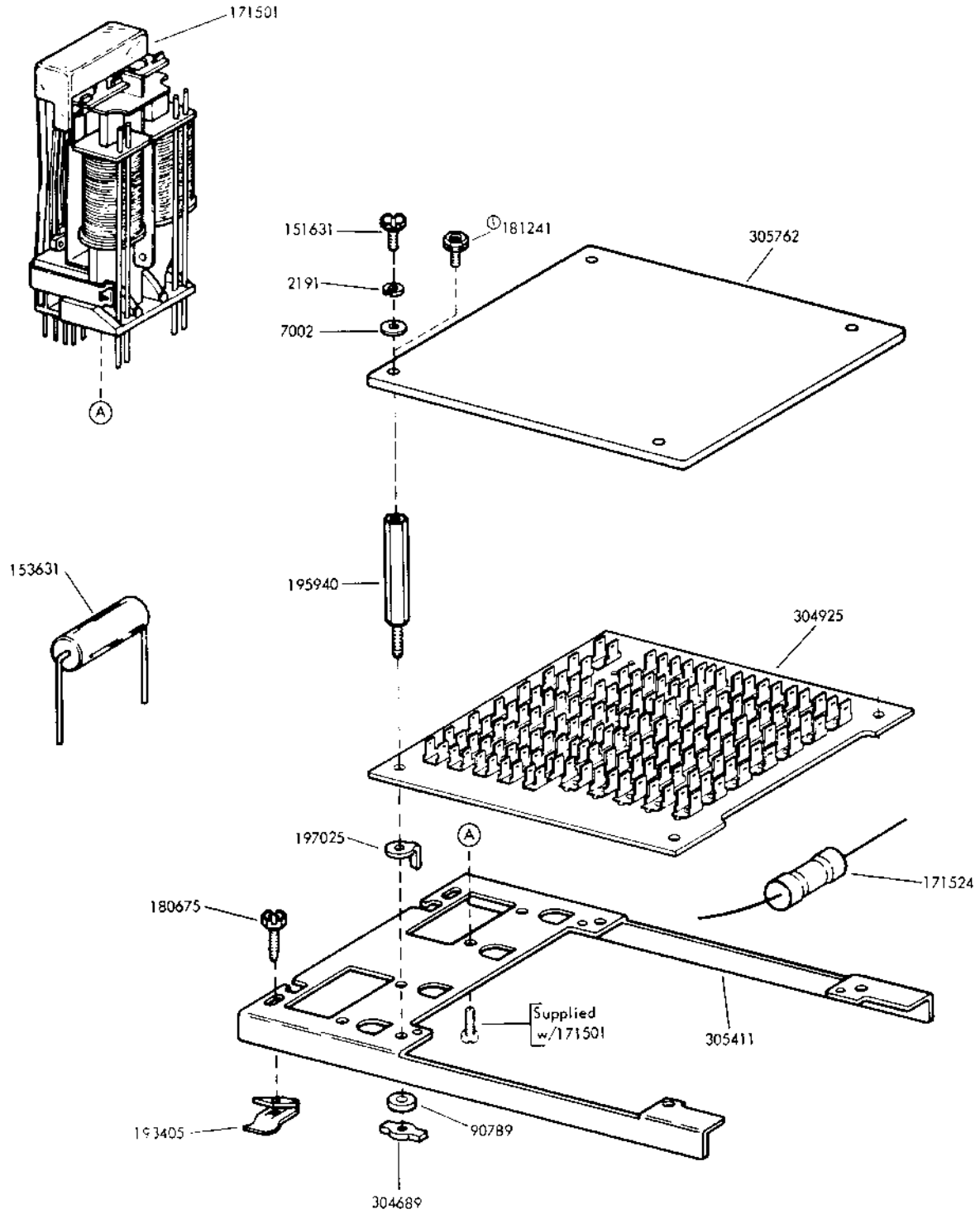

FIGURE 2. 193410, 193437, AND 305406 MOUNTING PLATE ASSEMBLIES



ⓐ Not part of 305417

FIGURE 3. 305417 MAIN TERMINAL BOARD ASSEMBLY

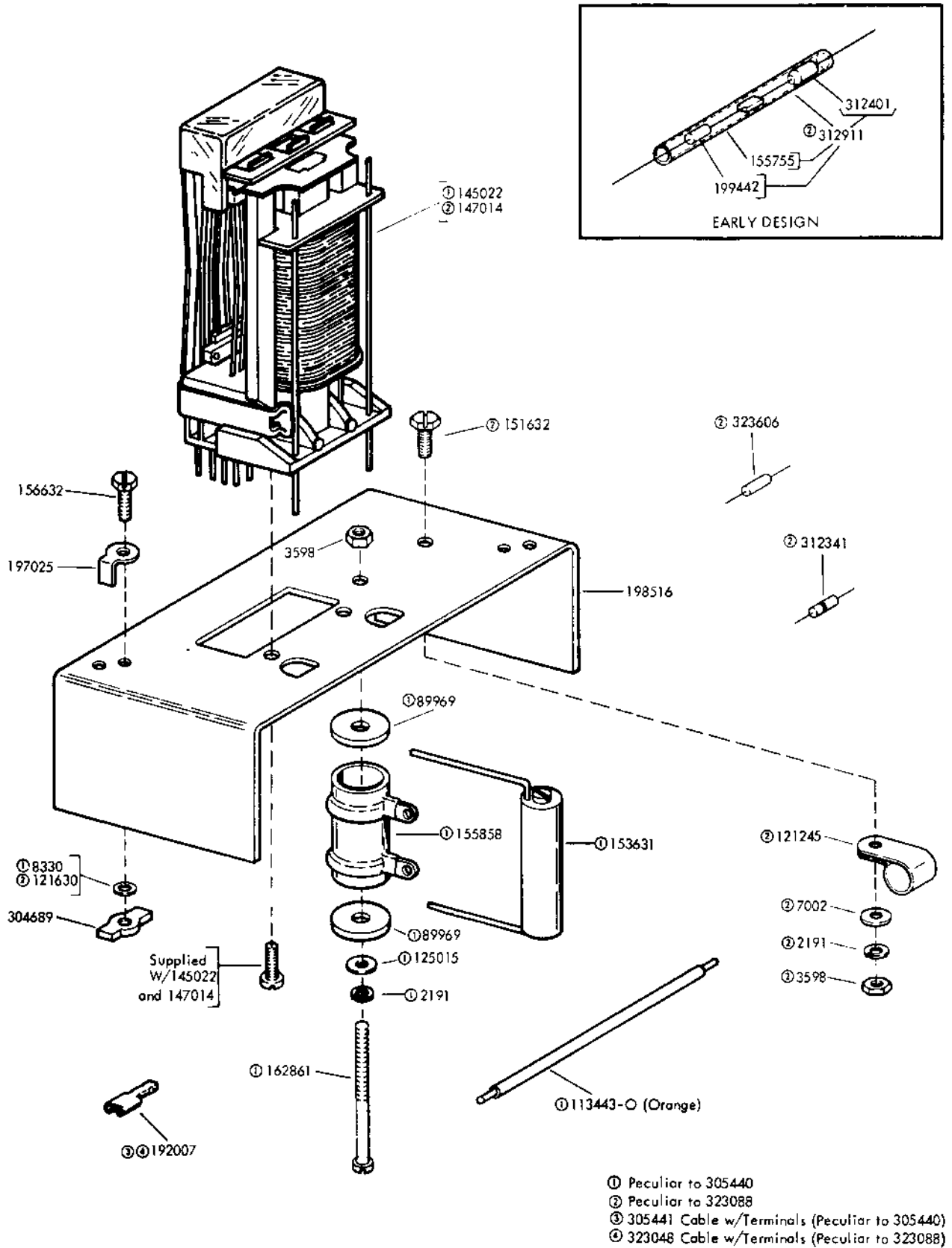

FIGURE 4. 305440 AND 323088 RELAY PLATE ASSEMBLIES

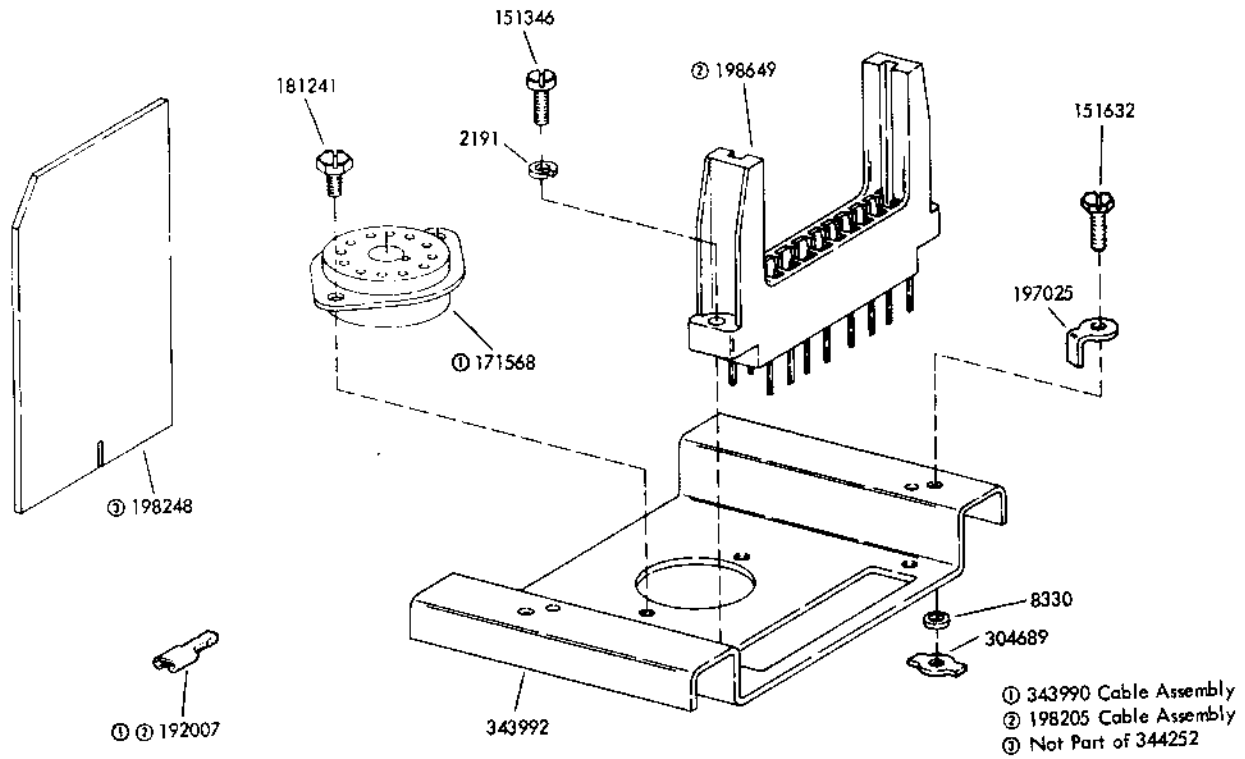

FIGURE 5. 344252 RELAY PLATE ASSEMBLY

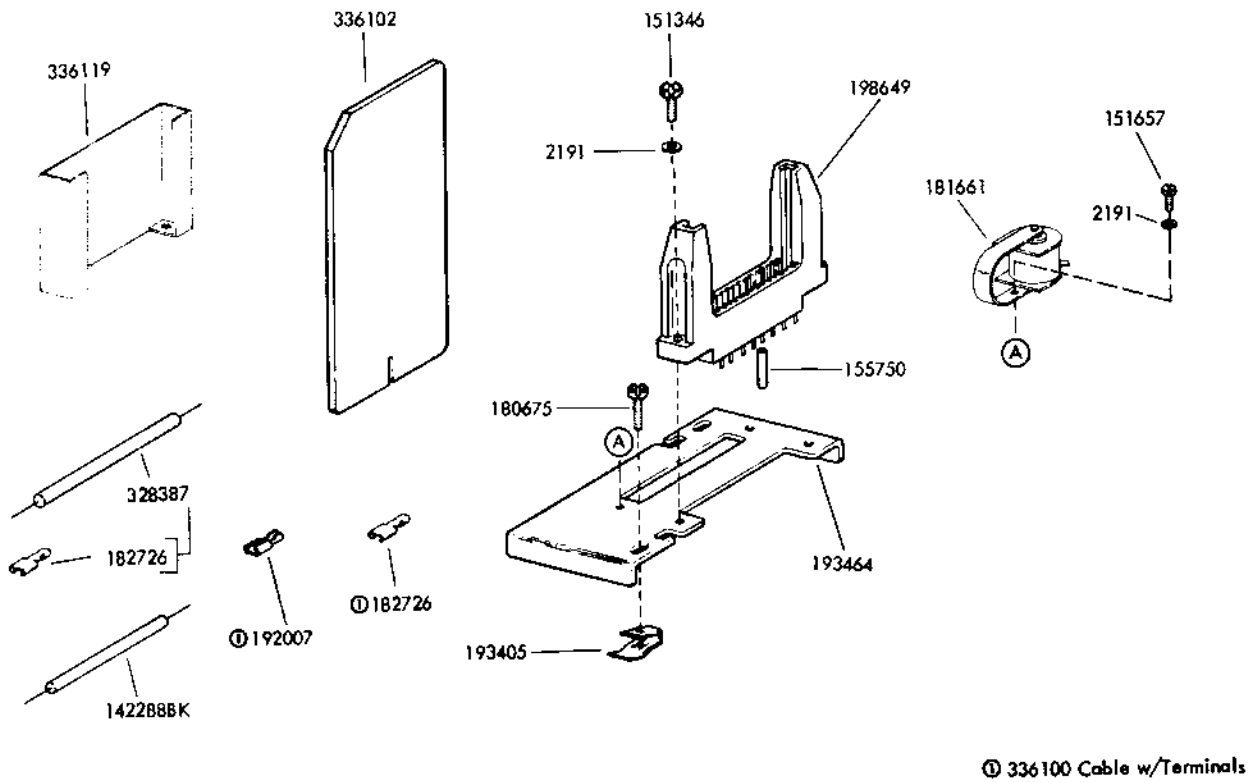

FIGURE 6. 336103 BUZZER ALARM ASSEMBLY

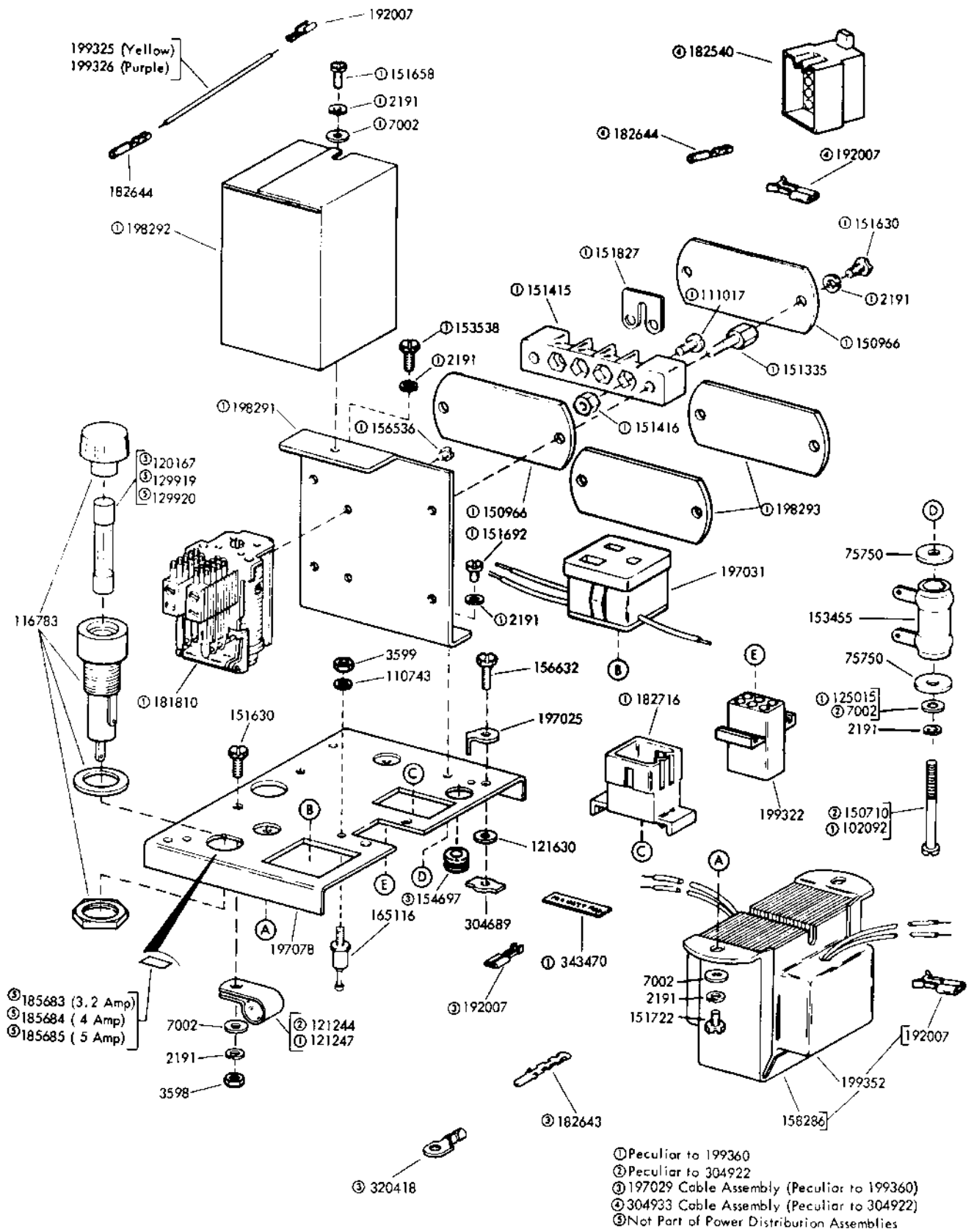

FIGURE 7. 199360 AND 304922 POWER DISTRIBUTION ASSEMBLIES

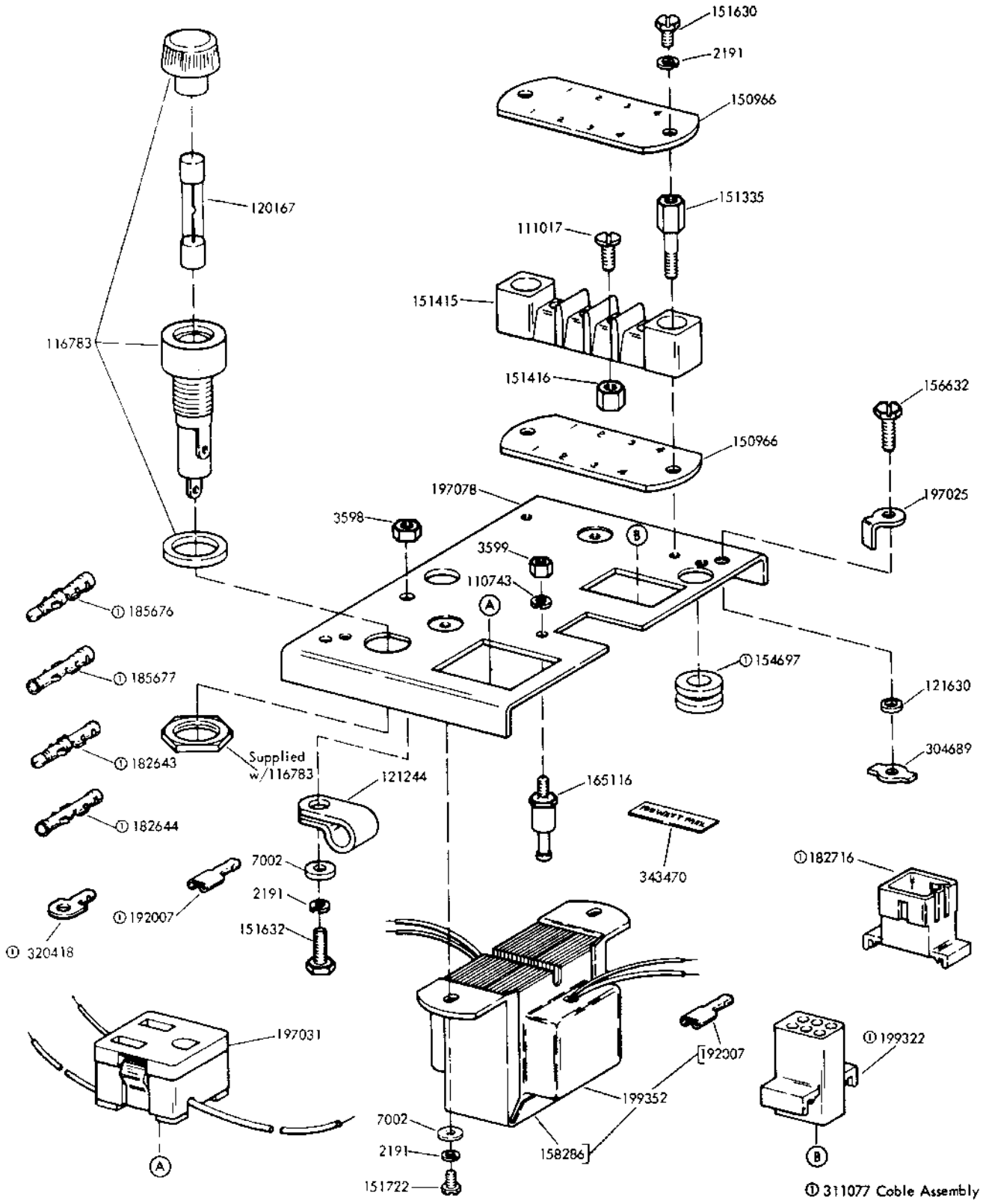

FIGURE 8. 311076 POWER DISTRIBUTION ASSEMBLY

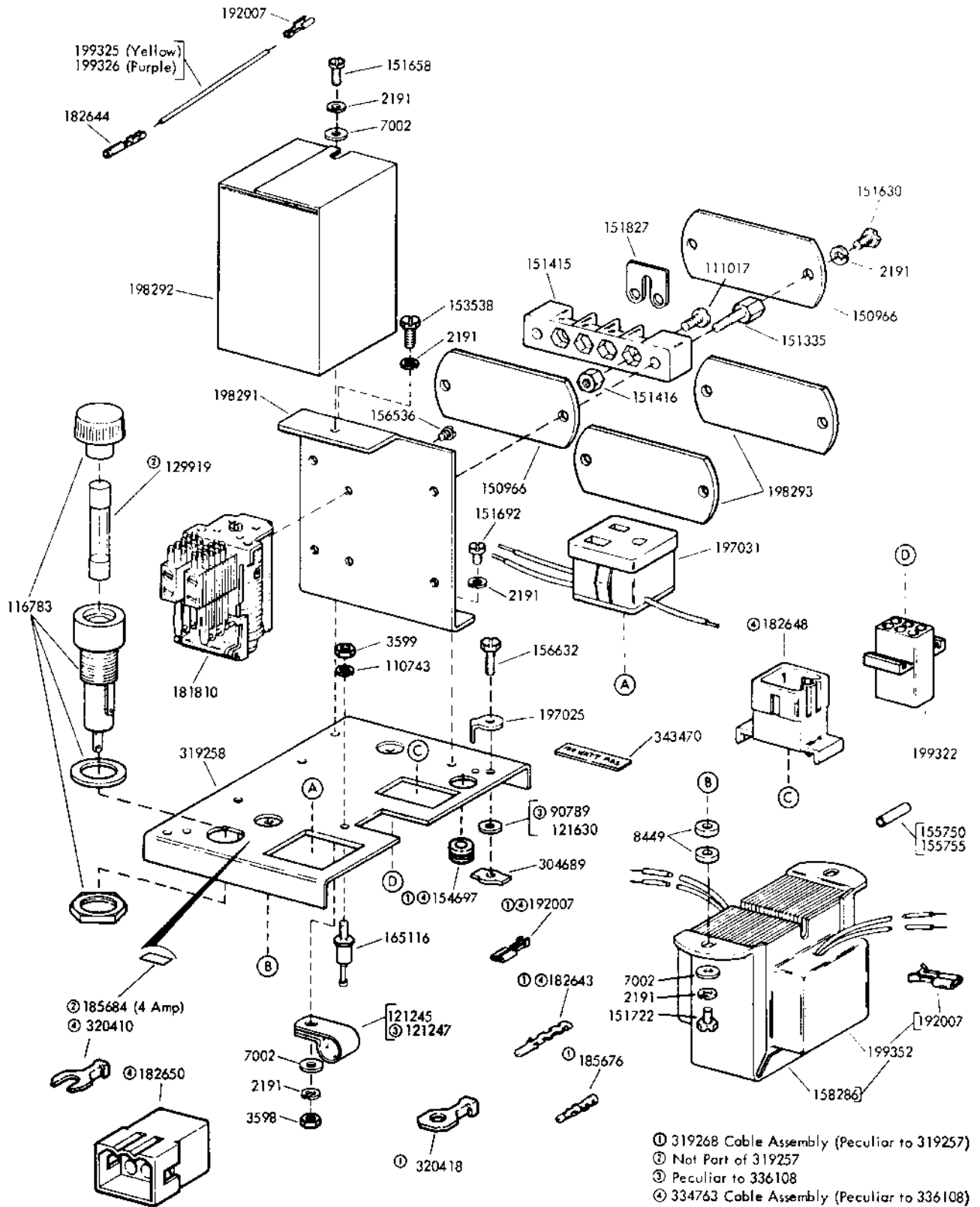

FIGURE 9. 319257 AND 336108 POWER DISTRIBUTION ASSEMBLIES

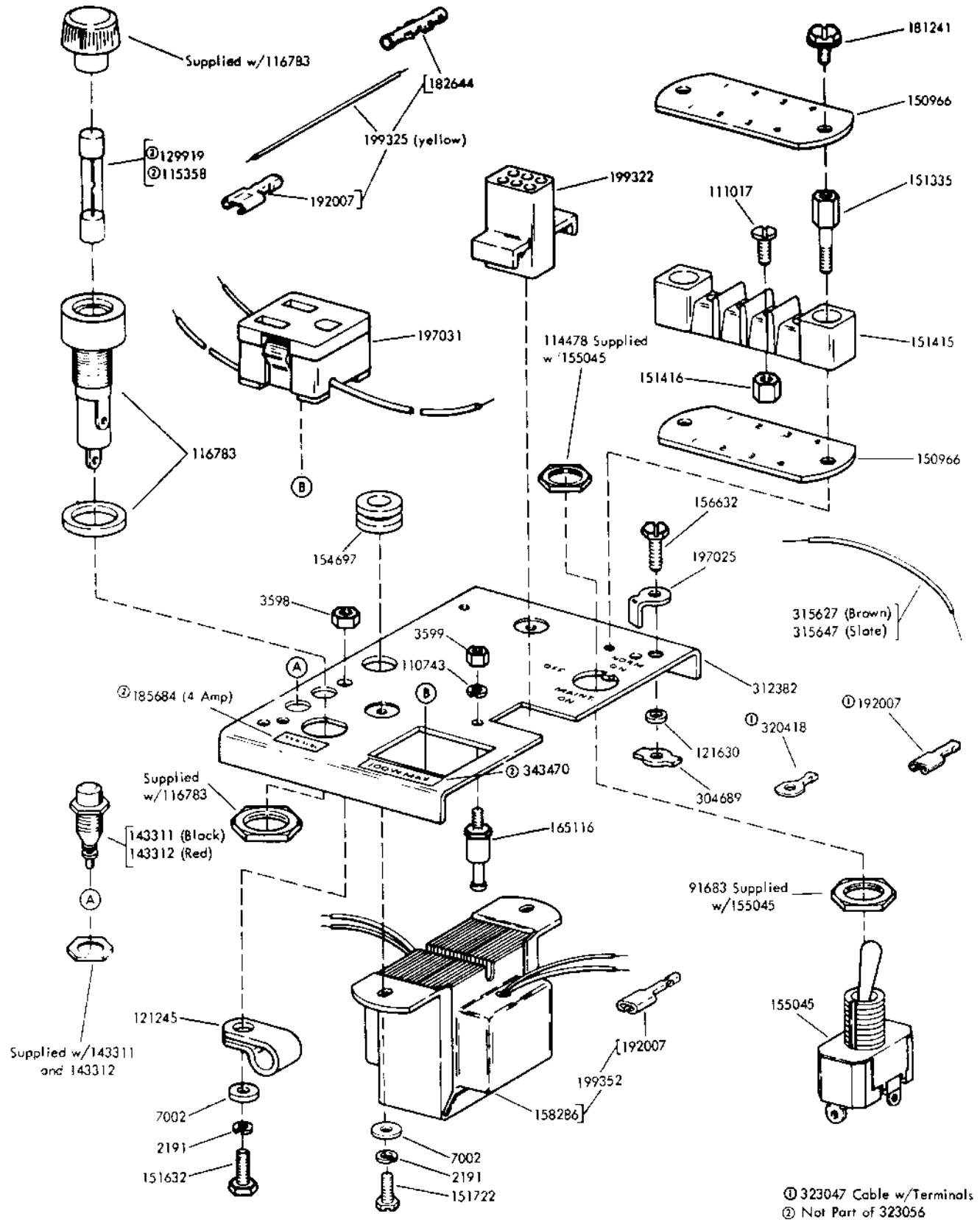

FIGURE 10. 323056 POWER DISTRIBUTION ASSEMBLY



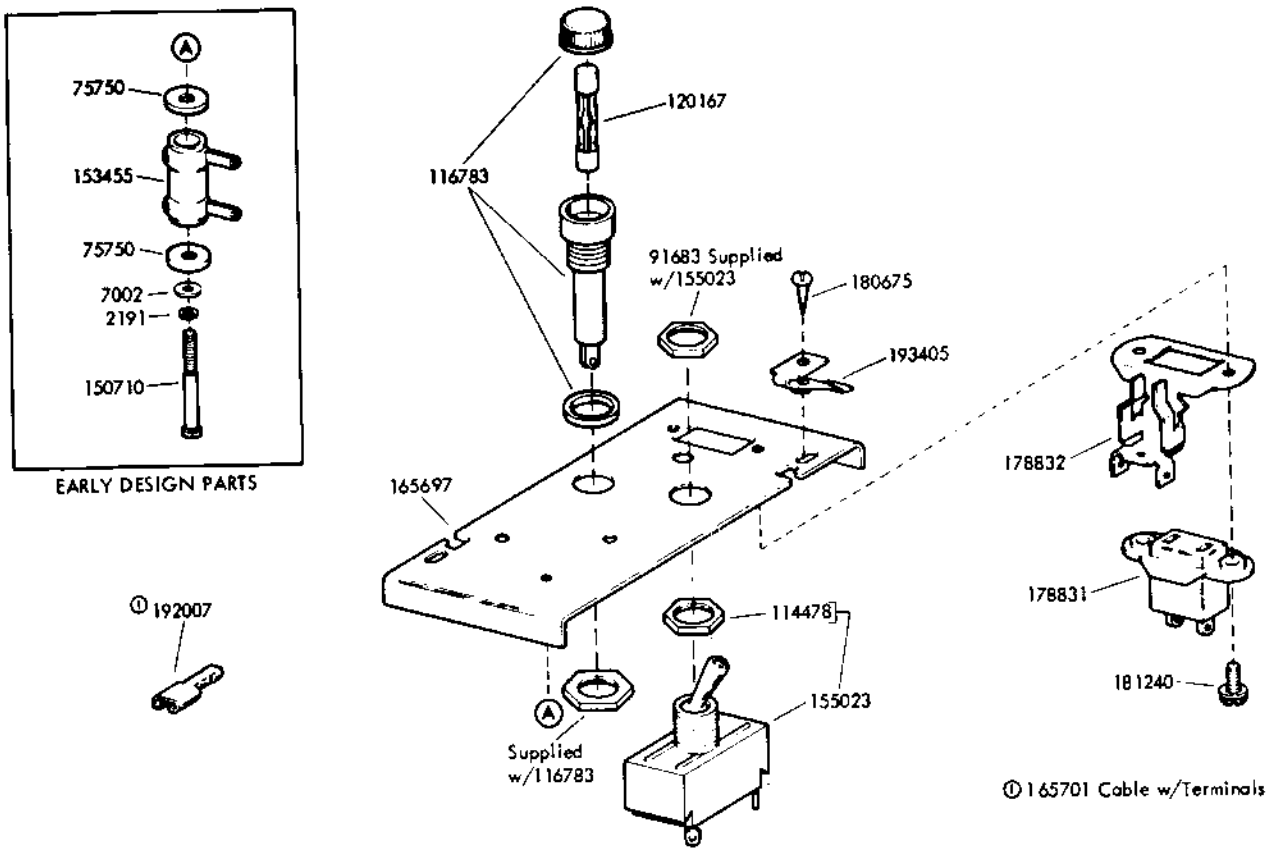

FIGURE 11. 165699 POWER DISTRIBUTION ASSEMBLY

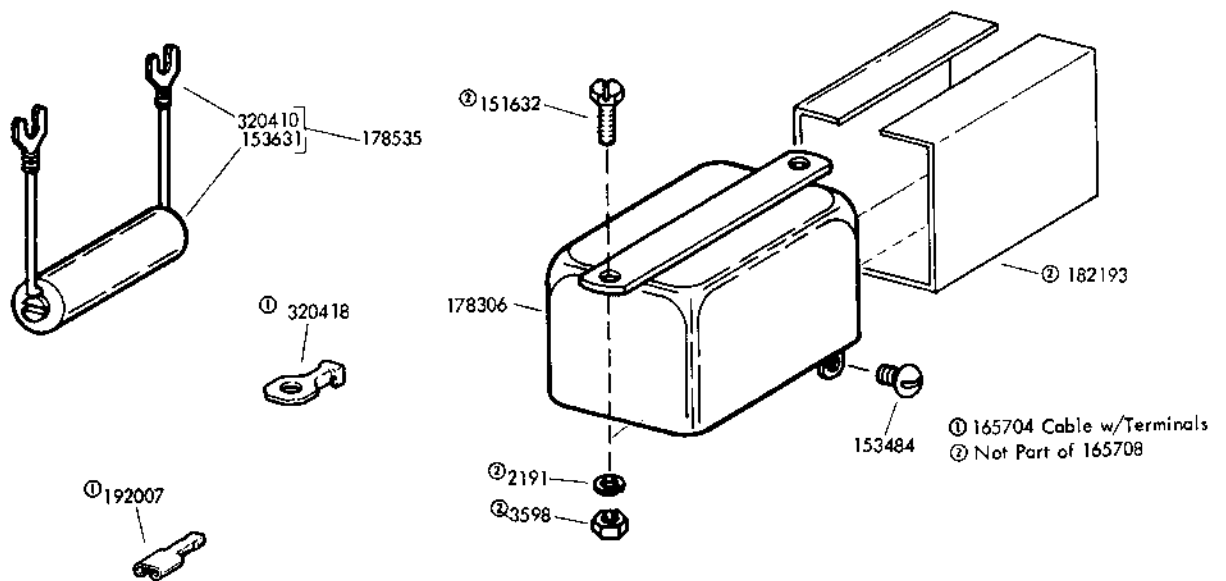

FIGURE 12. 165708 MOTOR CONTROL RELAY ASSEMBLY

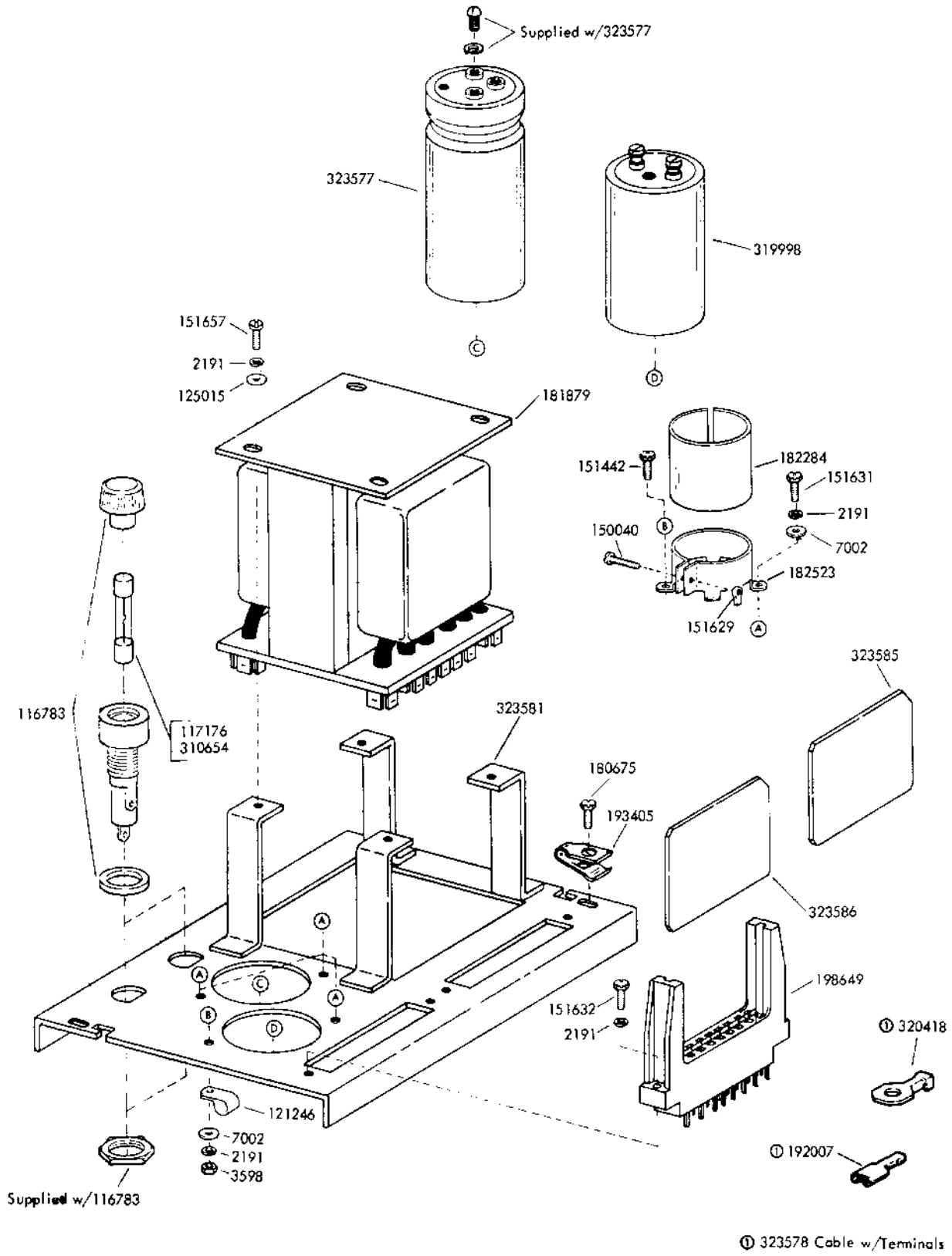

FIGURE 13. 323580 INTERFACE LOGIC ASSEMBLY

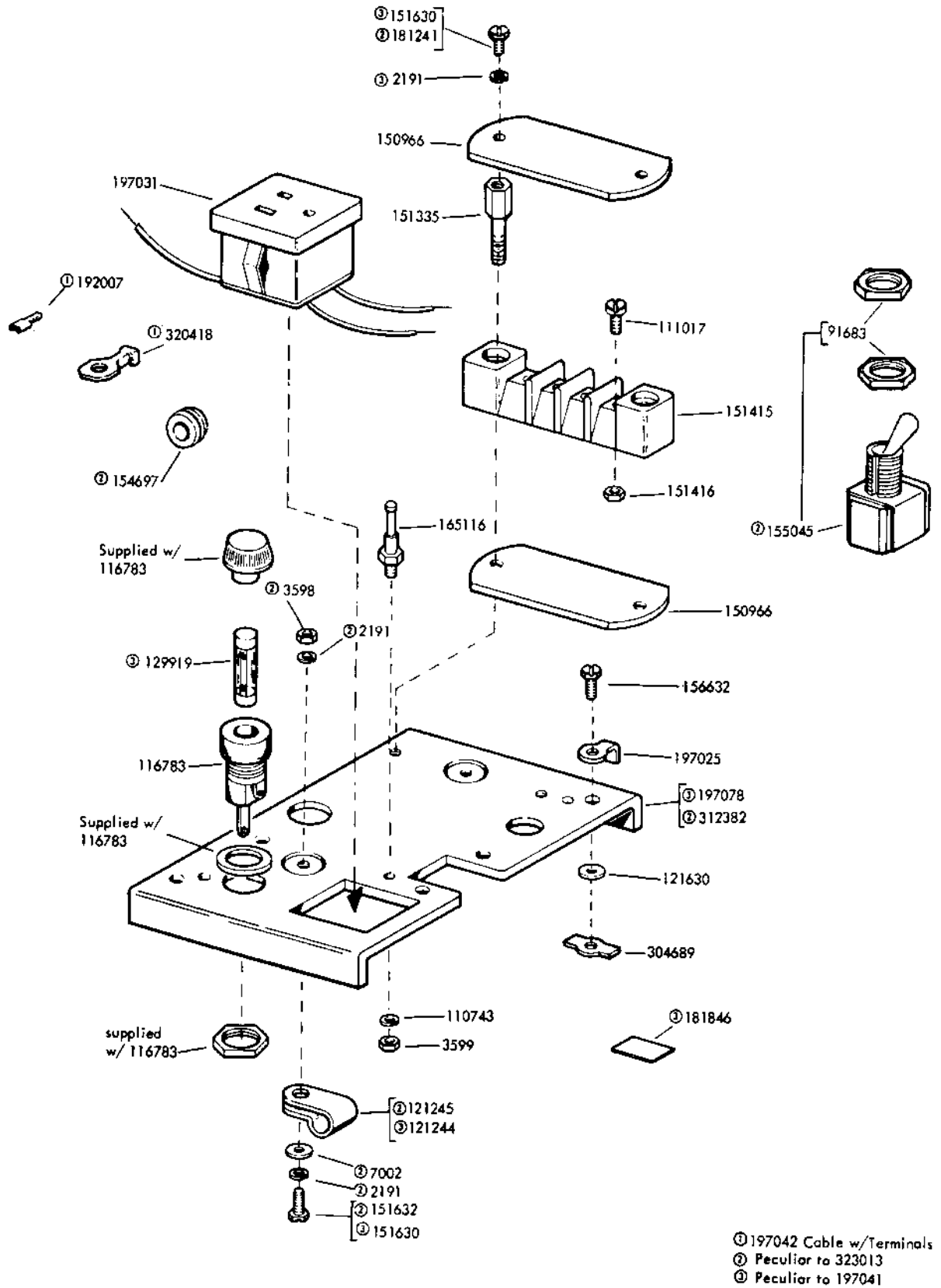

FIGURE 14. 197041 AND 323013 (ROTR) POWER DISTRIBUTION ASSEMBLIES

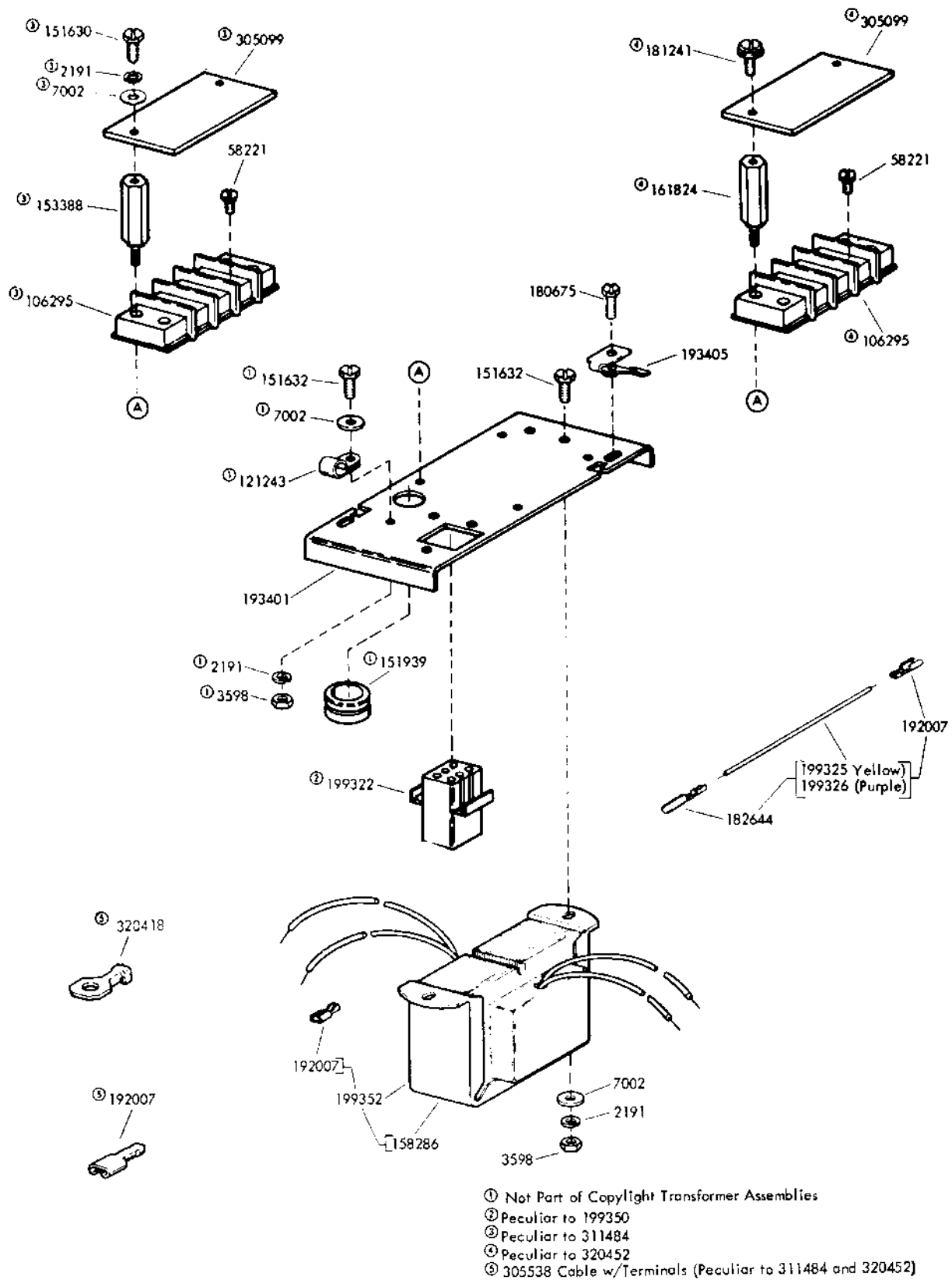

FIGURE 15. 199350, 311484 and 320452 COPYLIGT TRANSFORMER ASSEMBLIES

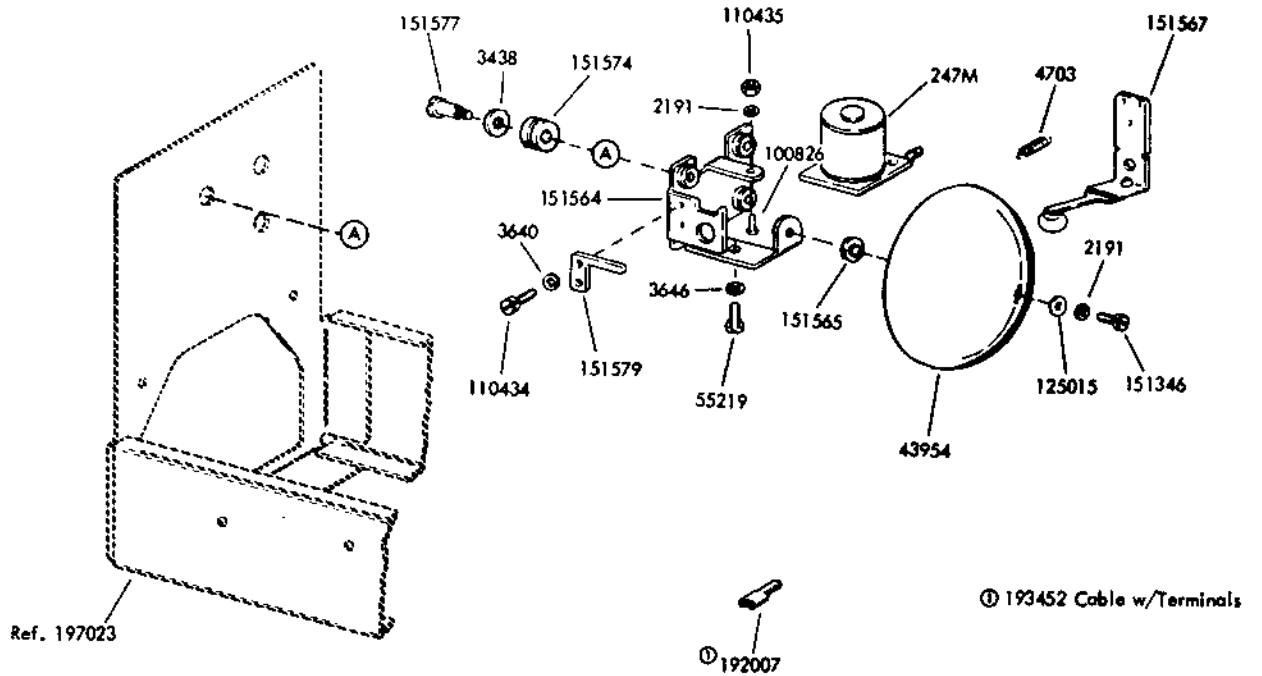

FIGURE 16. 193451 SIGNAL BELL ASSEMBLY

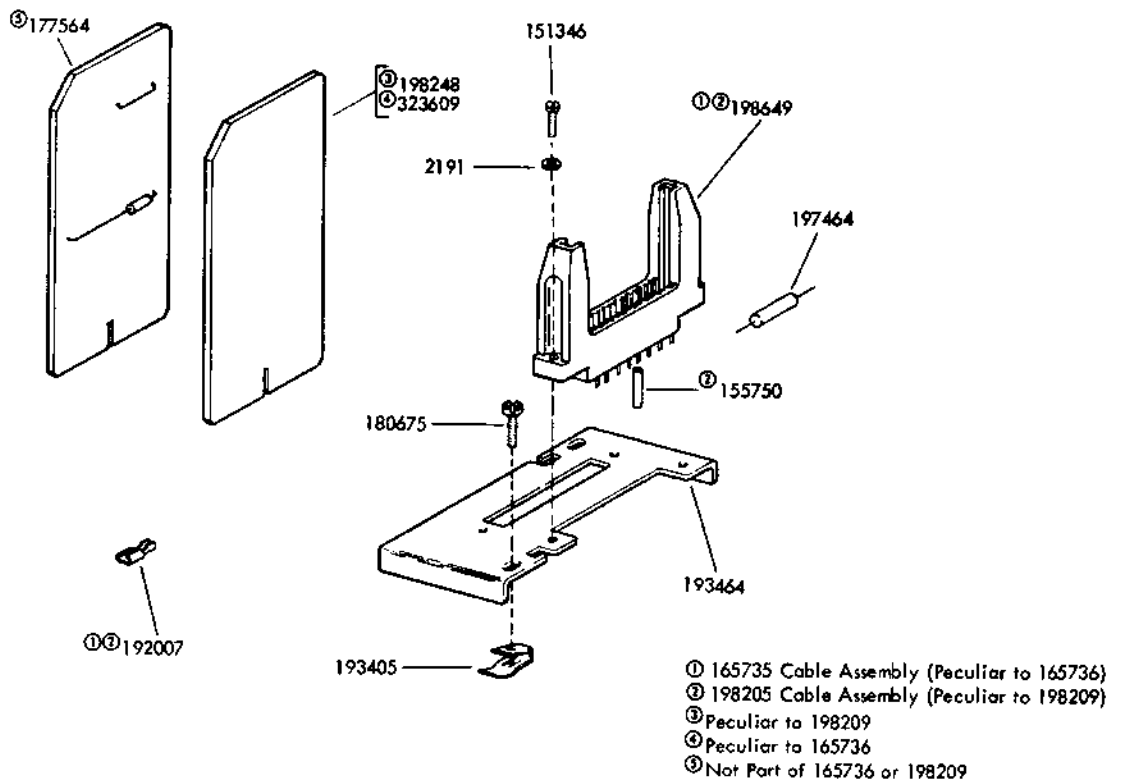

FIGURE 17. 165736 AND 198209 SIGNAL REGENERATOR ASSEMBLIES

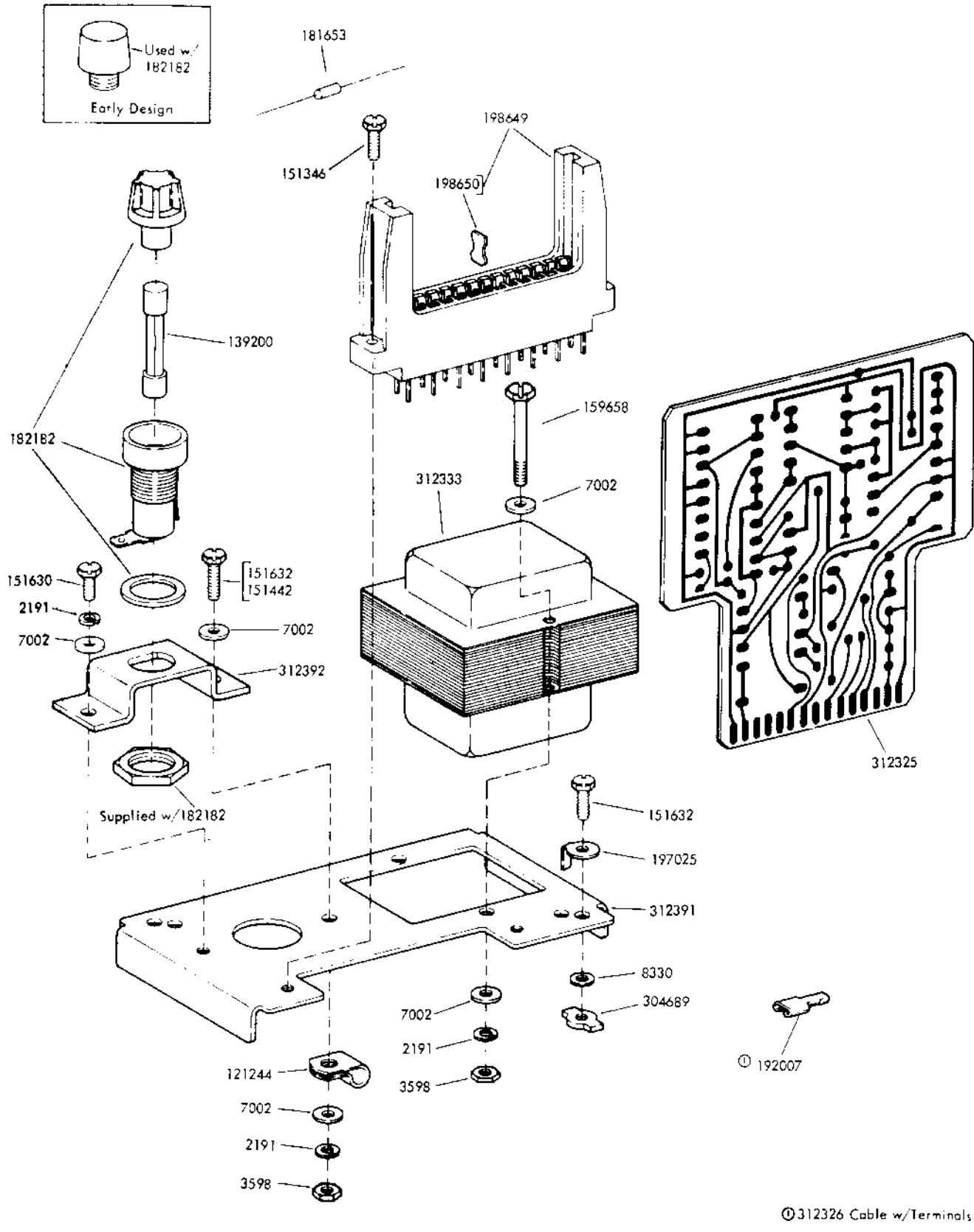

FIGURE 18. 305446 SIGNAL REGENERATOR ASSEMBLY

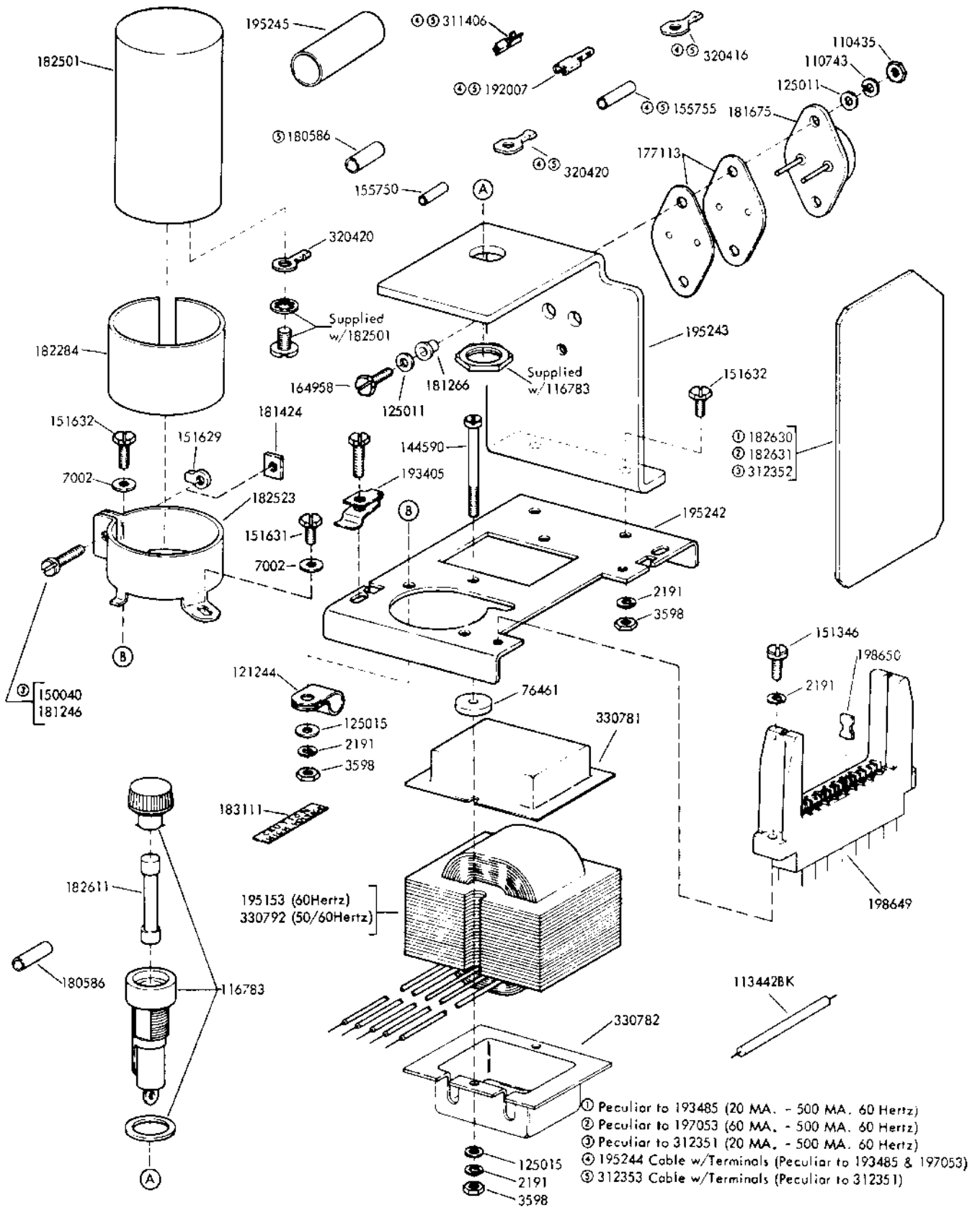

FIGURE 19. 193485, 197053, AND 312351 CONSTANT CURRENT SELECTOR MAGNET DRIVER ASSEMBLIES

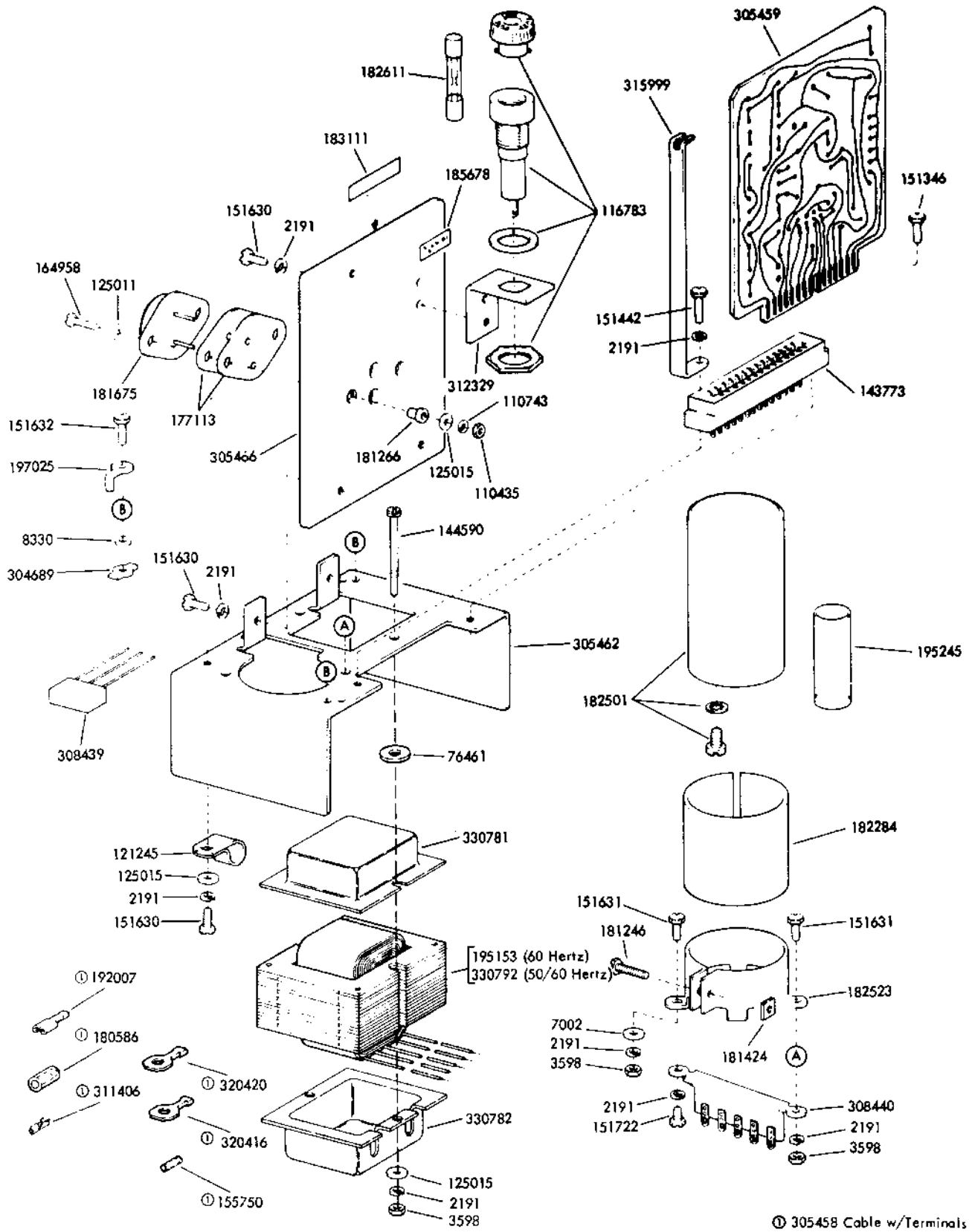
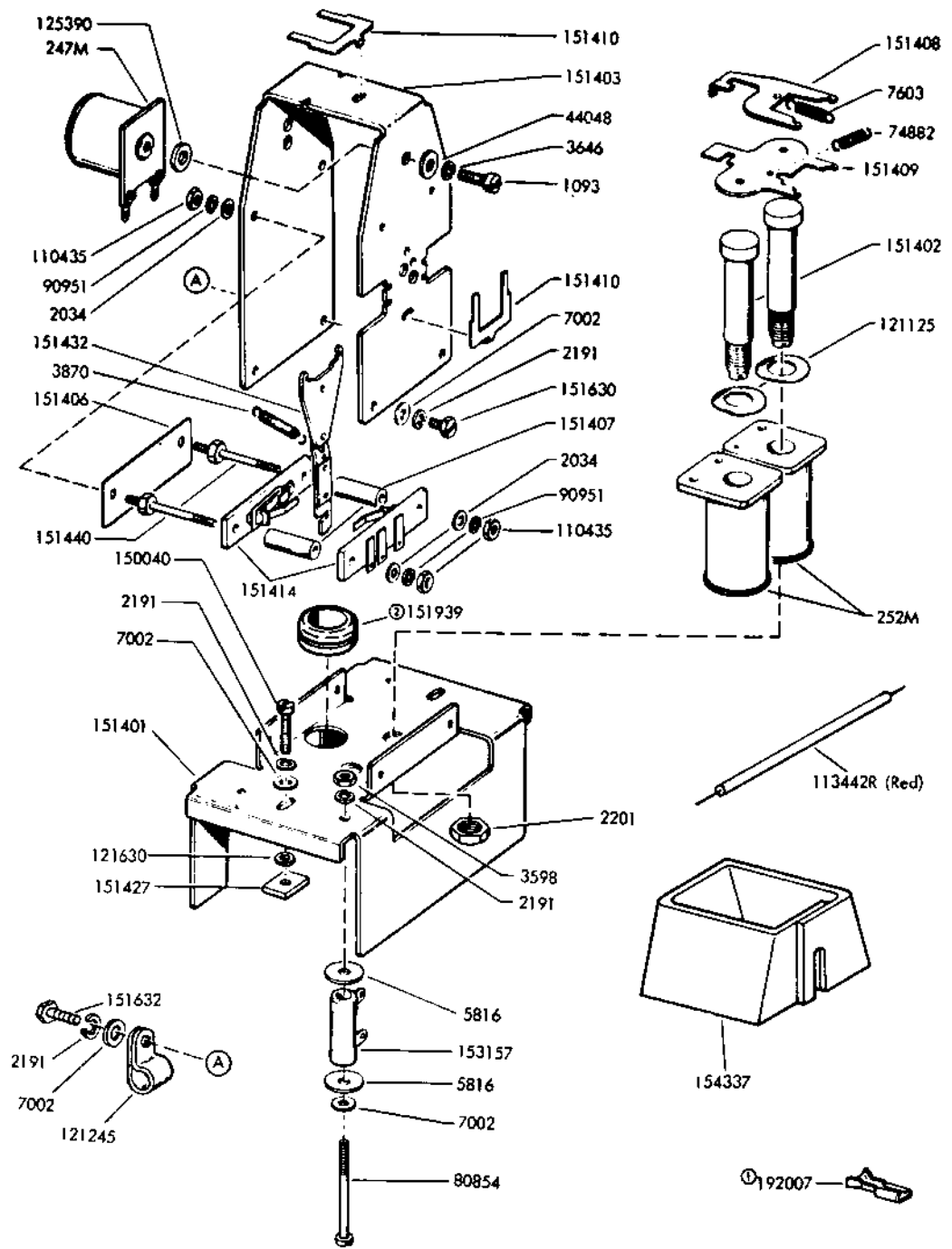

FIGURE 20. 305447 SELECTOR MAGNET DRIVER ASSEMBLY WITH BREAK DETECTOR





① 197057 Cable w/Terminals  
 ② Not Part of 197035

FIGURE 21. 197035 ELECTRICAL MOTOR CONTROL ASSEMBLY

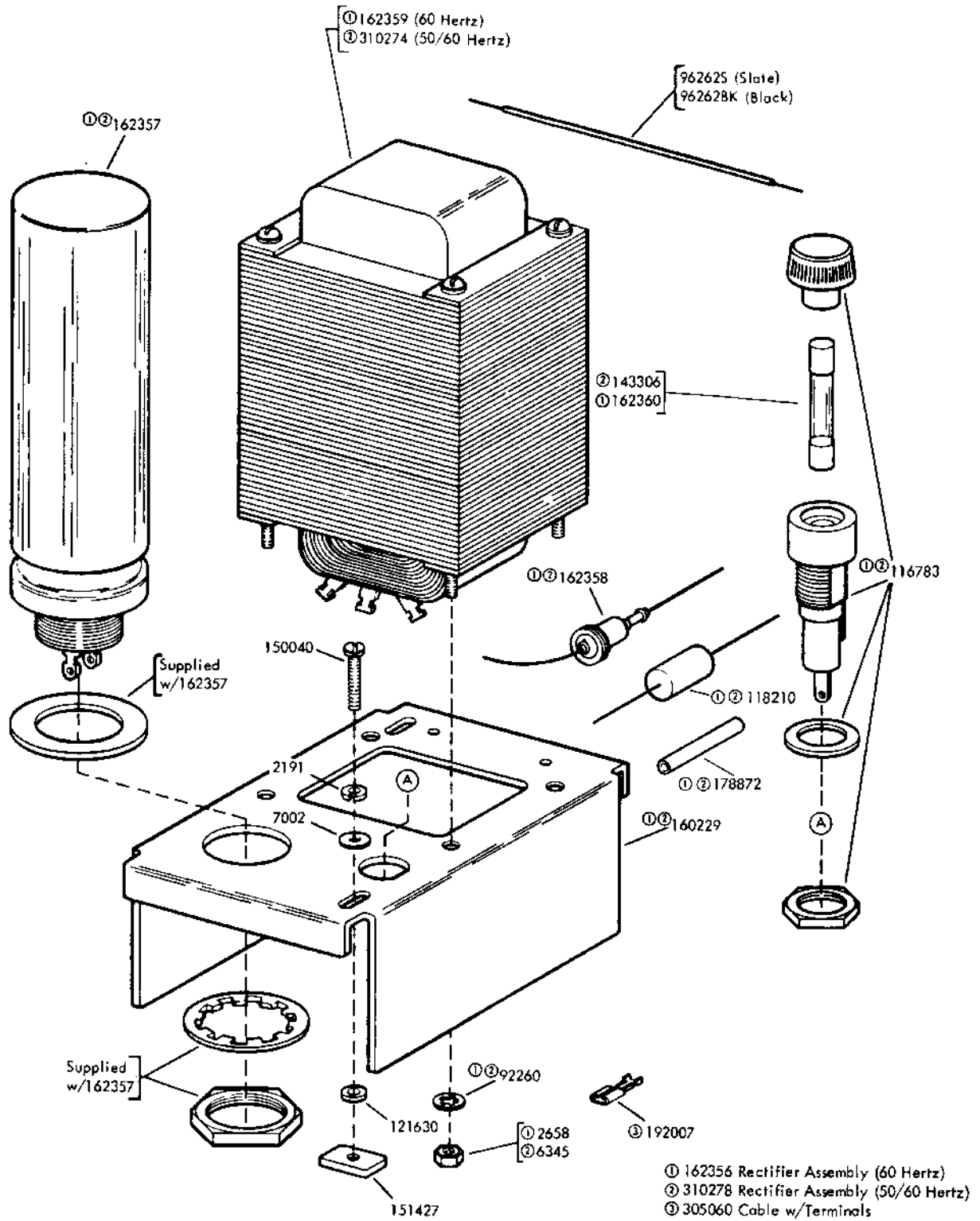

FIGURE 22. 305061 (60 HERTZ), 310707 (50/60 HERTZ), RECTIFIER AND CABLE ASSEMBLIES

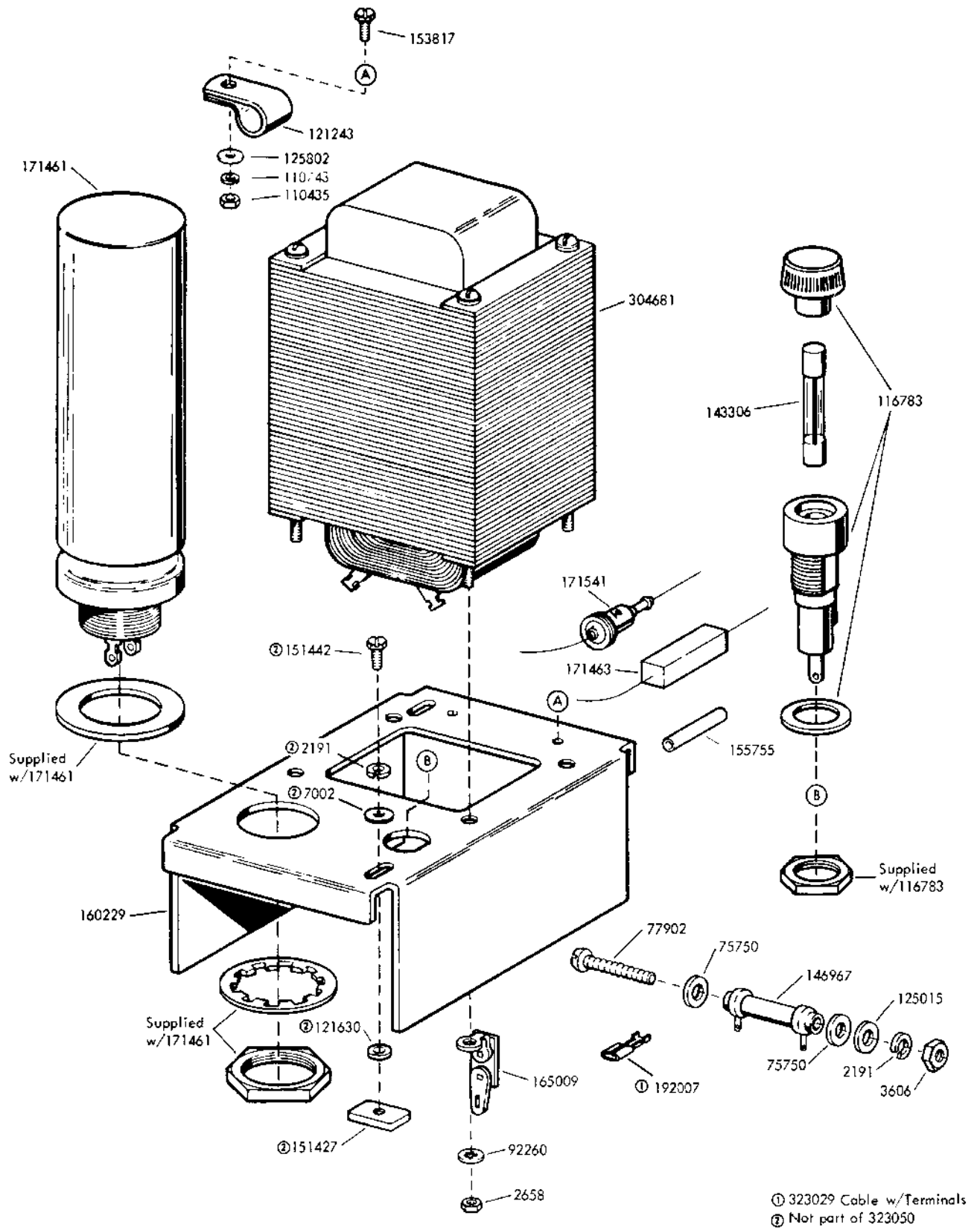

FIGURE 23. 323050 RECTIFIER ASSEMBLY

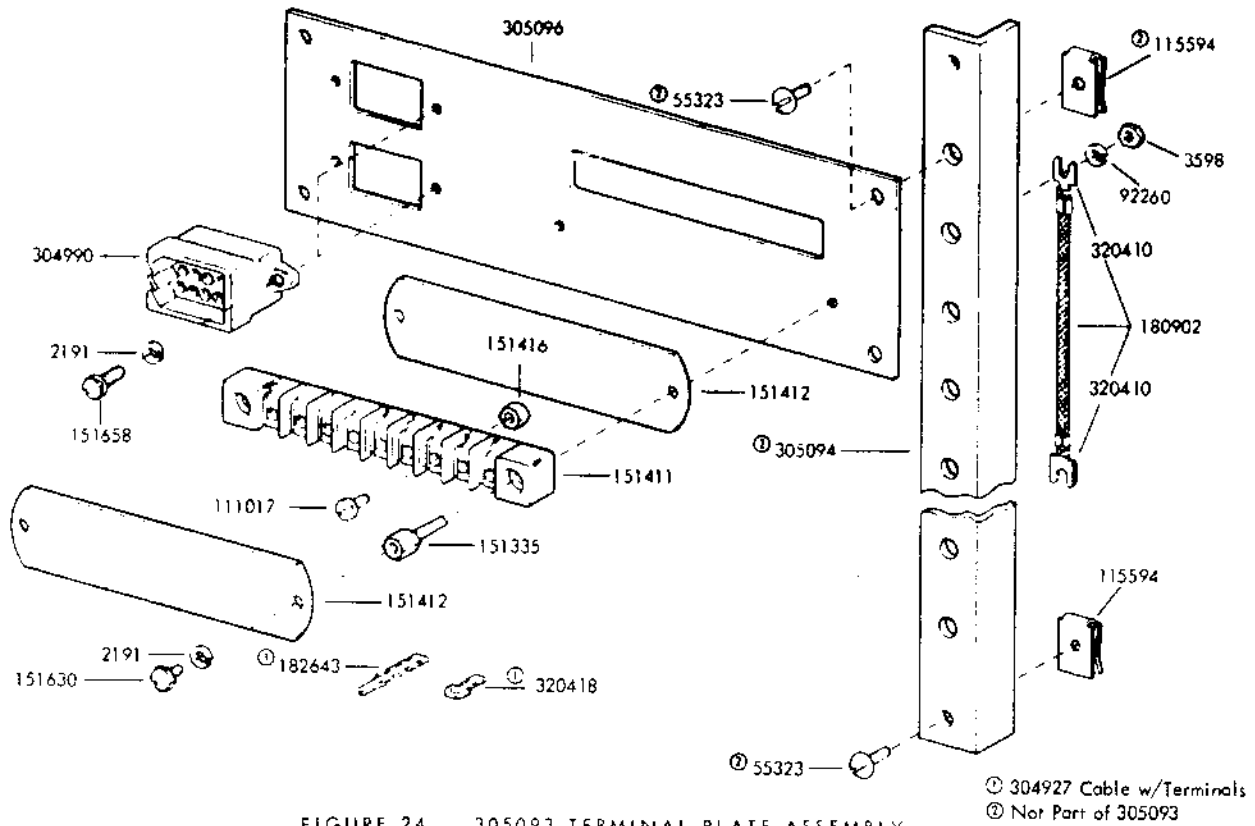

FIGURE 24. 305093 TERMINAL PLATE ASSEMBLY

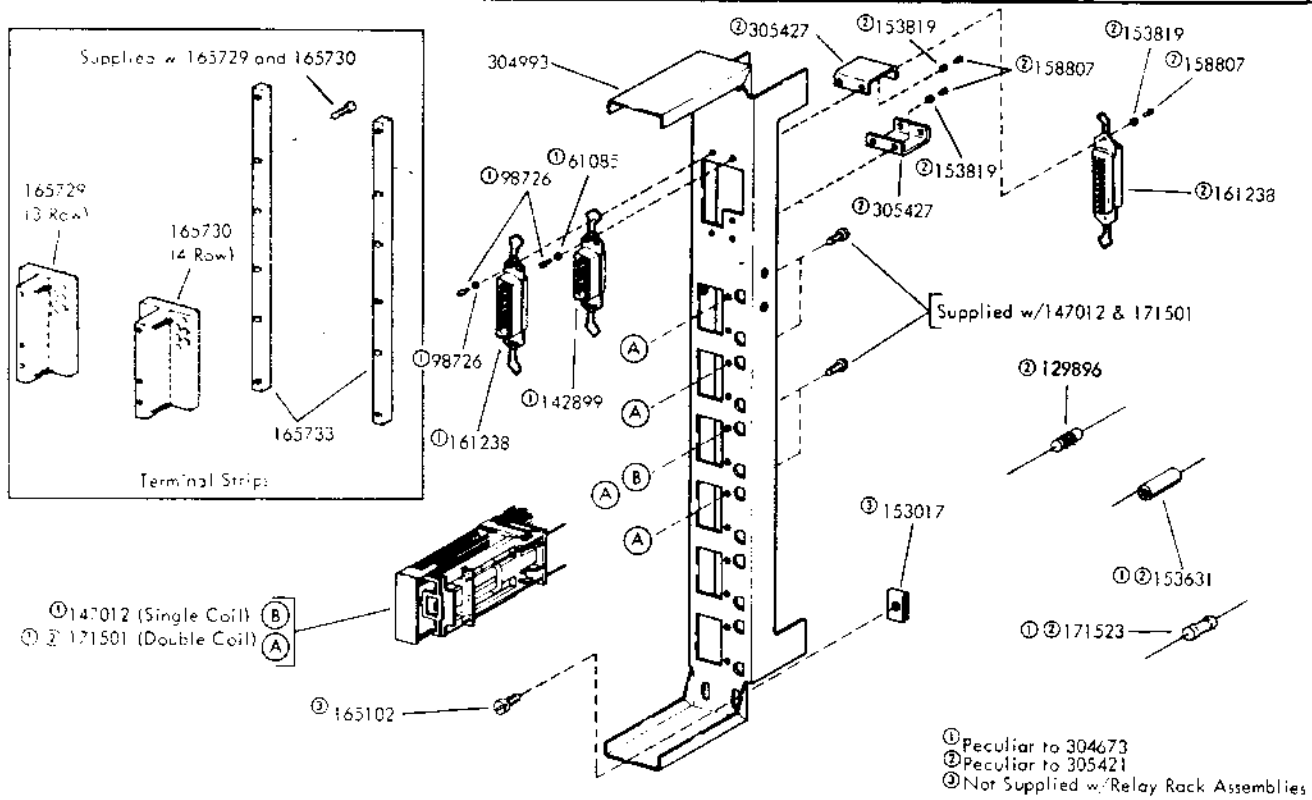

FIGURE 25. 304673 AND 305421 RELAY RACK ASSEMBLIES AND TERMINAL STRIPS

CABLE CLAMP		
Part Number	Width	I. D.
121242	3/8"	1/8"
121243	3/8"	3/16"
121244	3/8"	1/4"
121245	3/8"	5/16"
121246	3/8"	3/8"
121247	3/8"	7/16"
121248	3/8"	1/2"
121249	1/2"	5/8"
121250	1/2"	3/4"
121251	1/2"	1"
138999	1/2"	1-1/8"
162864	1/2"	7/8"

INSULATING SLEEVE		
Part Number	Length	I. D.
155751	1/2"	3/32"
155750	1"	1/8"
155751	1/2"	5/64"
155753	1/2"	1/8"
155754	1/2"	1/16"
155755	5/8"	11/64"
178871	1-1/8"	1/2"
181892	1"	9/64"

JUMPER		
Part Number	Length	Terminals
165710	8-1/2"	192007(1)
165726	10"	192007(1) 320420 (1)
193465	2-3/4"	173716(2)
193466	13"	192007(1)
193479	12"	320410 (2)
194989	9"	181392(1) 320418 (1)
197027	9"	181392(1)
197054	2-1/2"	192007(2)
198259	3"	192007(3)
198831	8"	192007(2)
199396	9"	192007(1) 181392(1)
307219	6"	192007(2)
311995	9 1/2"	192007(1) 320418(1)
320265	24"	192007(1)

Number in parentheses indicates quantity

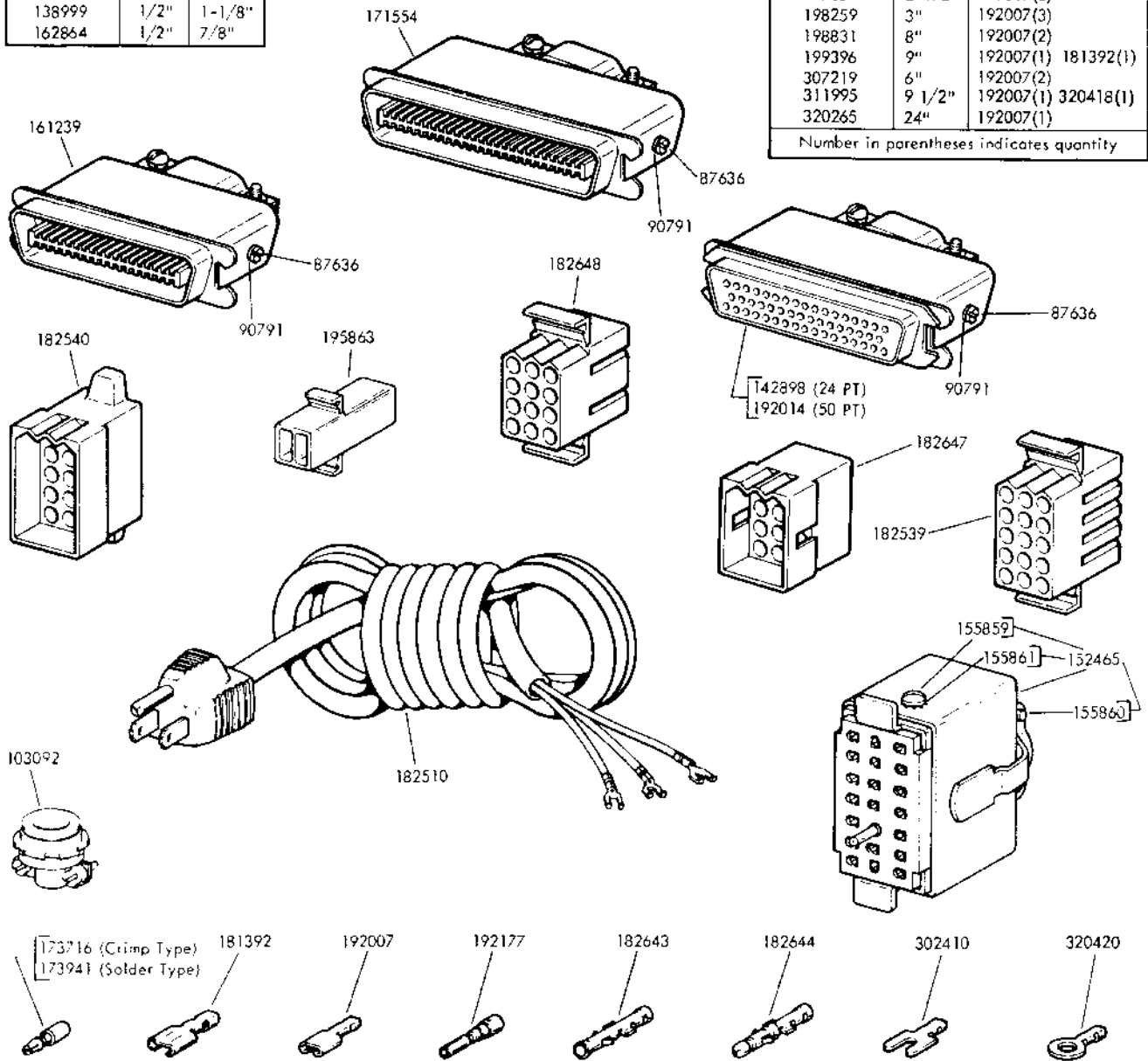

FIGURE 26. CABLE COMPONENTS

## NUMERICAL INDEX

Part Number	Description and Page Number	Part Number	Description and Page Number	Part Number	Description and Page Number
247M	Coil Magnet 15,19	98726	Screw, 3-48 x 1/4 Fil 22	125390	Washer, Flat 19
252M	Coil Magnet 19	100826	Screw, 4-40 x 3/16 Rd 15	125802	Washer, Flat 21
1098	Screw, 8-32 x 7/16 Fil 19	102092	Screw, 6-40 x 1-17/32 Rd 7	129851	Resistor, 3300 Ohm 3
2034	Washer, Flat 19	103092	Connector, Cord 23	129852	Resistor, 2200 Ohm 3
2191	Lockwasher 2 to 22	103469	Screw, 4-40 Spl 2	129896	Resistor, 1000 Ohm 22
2201	Nut, 5-16-32 Hex 19	106295	Block, Terminal 14	129919	Fuse, SL-BL 4 Amp 7,9,10,13
2658	Nut, 6-32 Hex 20,21	107116	Lockwasher 2	129920	Fuse, SL-BL 5 Amp 7
2669	Lockwasher 2	110434	Screw, 4-40 x 3/16 Fil 15	137602	Resistor, 470 Ohm 3
3438	Washer, Flat 15	110435	Nut, 4-40 Hex 15,17,18,19,21	138999	Clamp, 1-1/8 ID Cable 23
3598	Nut, 6-40 Hex 2,3,5,7 to 14,16 to 19,22	110743	Lockwasher 7,8,9,10,13,17,18,21	139200	Fuse, 1/8 Amp 16
3599	Nut, 4-40 Hex 7,8,9,10,13	111017	Screw, 6-40 x 5/16 Fil 7,8,9,10,13,22	142288BK	Jumper, 2" BK 6
3606	Nut, 6-40 Hex 21	112080	Washer, Flat 2	142898	Connector, 24 Pt Plug 23
3639	Lockwasher 2	113442BK	Jumper, 2-1/2" Black 17	142899	Connector, 24 Pt Receptacle 22
3640	Lockwasher 15	113442R	Jumper, 2-1/2" Red 19	143306	Fuse, SL-BL 1 Amp 20,21
3646	Lockwasher 15,19	113443O	Jumper, 3-1/2" Orange 5	143311	Jack, Black 10
3870	Spring 19	114478	Nut, 15/32-32 Hex 10,11	143312	Jack, Red 10
4703	Spring 15	114654	Strip, Terminal 3	143773	Connector, 15 Pt Circuit Card 18
5816	Washer, Insulating 19	115358	Fuse, 1 Amp 10	144590	Screw, 6-40 x 1-3/8 Fil 17,18
6345	Nut, 6-32 Hex 20	115594	Nut, Speed 2	145022	Relay 3,5
7002	Washer, Flat 2 to 5 7 to 14,16 to 21	116783	Holder, Fuse 7 to 13,17,18,20,21	146967	Resistor, 750 Ohm 21
7603	Spring 19	117176	Fuse, SL-BL .5 Amp 12	147012	Relay, 500 Ohm 22
8330	Washer, Flat 2,3,5,6,16,18	118187	Resistor, 27,000 Ohm 3	147014	Relay 5
8449	Spacer, .094" Thk 9	118203	Resistor, 4700 Ohm 2	150040	Screw, 6-40 x 5/8 Fil 12,17,19,20
34432	Washer, Flat 2	118210	Resistor, 22,000 Ohm 20	150710	Screw, 6-40 x 1-1/4 Fil 7,11
43954	Bell 15	120167	Fuse, SL-BL 3.2 Amp 7,8,11	150966	Insulator, Terminal Block 7,8,9,10,13
44048	Washer, Flat 19	121125	Washer, Spring 19	151335	Stud 7,8,9,10,13,22
55219	Screw, 8-32 x 3/8 Fil 15	121242	Clamp, 1/8 ID Cable 23	151346	Screw, 6-40 x 3/8 Fil 6,15 to 18
55323	Screw, 8-32 x 1/2 Rd 22	121243	Clamp, 3/16 ID Cable 14,21,23	151401	Base 19
58221	Screw 6-32 x 1/4 Fil 14	121244	Clamp, 1/4 ID Cable 7,8,13,16,17,23	151402	Core 19
61085	Lockwasher 22	121245	Clamp, 5/16 ID Cable 5,9,10,13,18,19,23	151403	Frame 19
74882	Spring 19	121246	Clamp, 3/8 ID Cable 12,23	151406	Plate, Insulating 19
75750	Washer, Insulating 7,11,21	121247	Clamp, 7/16 ID Cable 7,9,23	151407	Collar, Spacing 19
76461	Washer, Flat 17,18	121248	Clamp, 1/2 ID Cable 23	151408	Lever 19
77902	Screw, 6-40 x 2-3/8 Rd 21	121249	Clamp, 5/8 ID Cable 23	151409	Armature 19
80854	Screw, 6-40 x 1-7/16 Fil 19	121250	Clamp, 3/3 ID Cable 23	151410	Clip, Retaining 19
87636	Screw, 2-56 x 3/16 Rd 23	121251	Clamp, 1ID Cable 23	151411	Block, Terminal 22
89969	Washer, Insulating 5	121630	Washer, Flat 5,7 to 10,13,19,20,21	151412	Insulator, Terminal Block 22
90789	Washer, Flat 4,9	125011	Washer, Flat 17,18	151414	Switch, Sensitive 19
90790	Washer, Flat 2	125015	Washer, Flat 2,5,7,12,15,17,18,21	151415	Block, Terminal 7 to 10,13
90791	Lockwasher 23				
90951	Lockwasher 19				
91683	Nut, 15/32 Hex 10,11,13				
92250	Lockwasher 20,21,22				
94665	Screw, 6-40 Shoulder 2				
96262BK	Jumper, 4" Black 20				
96262S	Jumper, 4" Slate 20				

## NUMERICAL INDEX (Continued)

Part Number	Description and Page Number	Part Number	Description and Page Number	Part Number	Description and Page Number
151416	Nut, 6-40 Hex 7 to 10, 13, 22	155750	Sleeve, 3/32 ID x 1/2" Lg Insulating 6,9,15,17,18, 23	165710	Jumper, 8-1/2" Green 23
151427	Plate, Clamp 19,20,21	155751	Sleeve, 1/8 ID x 1" Lg Insulating 23	165726	Jumper, 10" Black 23
151432	Armature 19	155753	Sleeve, 1/8 ID x 1/2" Lg Insulating 23	165729	Block, 3 Row Terminal 22
151440	Stud 19	155754	Sleeve, 1/16 ID x 1/2" Lg Insulating 23	165730	Block, 4 Row Terminal 22
151442	Screw, 6-40 x 1/2 Hex 2, 12,16,18,21	155755	Sleeve, 11/64 ID x 5/8" Lg Insulating 5,9,17,21, 23	165733	Bar, Mounting 22
151564	Bracket 15	155858	Resistor, 700 Ohm 5	165735	Cable Assembly 15
151565	Bushing, Shoulder 15	155859	Screw, 4-40 Spl 23	165736	Regenerator Assembly, Signal 1,15
151567	Armature w/Clapper 15	155860	Screw, 4-40 x 3/8 Rd 23	171461	Capacitor, 900 MFD 21
151574	Grommet, Rubber 15	155861	Lockwasher 23	171463	Resistor, 1 Ohm 21
151577	Screw, 6-40 Shoulder 15	156536	Screw, 4-40 x 1/8 Fil 7,9	171501	Relay 4,22
151579	Plate, Retaining 15	156632	Screw, 6-40 x 13/32 Hex 5,7,8,9,10,13	171523	Resistor, 500 Ohm 22
151629	Nut, 6-40 Lug 12,17	158286	Transformer 7,8,9,10,14	171524	Resistor, 700 Ohm 2 to 4
151630	Screw, 6-40 x 1/4 Hex 7, 8,9,13,14,16,18,19,22	158807	Screw, 3-48 x 11/64 Fil 22	171525	Resistor, 1000 Ohm 3
151631	Screw, 6-40 x 5/16 Hex 2, 3,4,12,17,18	159658	Screw, 6-40 x 1-3/32 Hex 16	171541	Diode 2,21
151632	Screw, 6-40 x 3/8 Hex 5, 6,8,10 to 14, 16 to 19	160229	Plate, Mounting 20,21	171554	Connector, 50 Pt Plug 23
151657	Screw, 6-40 x 1/4 Fil 6,12	160847	Stud 2,3	171568	Socket, 11 Pt 6
151658	Screw, 6-40 x 5/16 Fil 7, 9,22	161238	Connector 36 Pt Receptacle 22	171580	Resistor, 470 Ohm 2
151692	Screw, 6-40 x 3/16 Fil 7,9	161239	Connector, 36 Pt Plug 23	173716	Terminal, Receptacle 23
151722	Screw, 6-40 x 3/16 Hex 7 to 10, 18	161824	Stud 14	173941	Terminal Receptacle Type 23
151724	Screw, 10-32 x 5/8 Hex 2	162356	Rectifier Assembly 20	177100	Rectifier 3
151827	Strap, Terminal 7,9	162357	Capacitor, 500 MFD 20	177108	Diode 3
151939	Grommet, Rubber 14,19	162358	Diode 20	177113	Insulator 17,18
152465	Connector, 20 PT Receptacle 23	162359	Transformer, Power 20	177564	Card, EC564 Circuit 15
153017	Nut, Speed 22	162360	Fuse, SL-BL .8 Amp 20	178306	Relay, Power 11
153157	Resistor, 400 Ohm 19	162861	Screw, 6-40 x 1-7/16 5	178535	Suppressor, Spark 11
153388	Stud 14	162864	Clamp, 7/8 ID Cable 23	178831	Connector, 2 Pt Receptacle 11
153442	Screw, 10-32 x 1/2 Hex 2	164958	Screw, 4-40 x 1/2 Hex 17, 18	178832	Plate, Adapter 11
153455	Resistor, 600 Ohm 7,11	165008	Turret, Terminal 2,3	178848	Diode 3
153484	Screw, 6-32 Spl 11	165009	Terminal 21	178871	Sleeve, 1/2 ID x 1-1/2" Lg Insulating 23
153538	Screw, 6-40 x 7/16 Hex 7,9	165102	Screw, 12-24 x 3/8 Rd 22	178872	Sleeve, 1/16 ID x 1-1/4" Lg Insulating 20
153631	Network, Spark Suppression 2 to 5, 11,22	165116	Terminal 7 to 10,13	180586	Sleeve, 5/32 ID x 21/32" Lg Insulating 17,18
153632	Cable Assembly 2	165330	Resistor, 1000 Ohm 3	180675	Screw, No. 6 Self-Tapping 3,4,6,11,12,14,15
153817	Screw, 4-40 x 3/8 Hex 21	165697	Plate, Mounting 11	180902	Jumper, 3-1/2" Braided 22
153819	Lockwasher 22	165699	Distribution Assembly, Power 1,11	181240	Screw w/Lockwasher, 6-40 x 3/16 Hex 11
154337	Cover 19	165701	Cable w/Terminals 11	181241	Screw w/Lockwasher, 6-40 x 1/4 Hex 4,6,10,13,14
154697	Grommet, Rubber 7,8,9,10,13	165704	Cable w/Terminals 11	181246	Screw w/Lockwasher 6-40 x 5/8 Hex 17,18
155023	Switch, DP-DT Toggle 11	165708	Relay Assembly 1,11	181266	Bushing, Insulating 17,18
155045	Switch, SP-DT Toggle 10, 13			181392	Terminal, Tab Type 23
				181424	Nut, 6-40 Sq 17,18
				181653	Diode 16

## NUMERICAL INDEX (Continued)

Part Number	Description and Page Number	Part Number	Description and Page Number	Part Number	Description and Page Number
181654	Diode 2	192014	Connector, 50 Pt Receptacle Type 23	197041	Distribution Assembly, Power 1,13
181661	Buzzer, 115v AC 6	192177	Terminal, Receptacle Type 23	197042	Cable Assembly 13
181675	Transistor, Power 17,18	192273	Nut, Speed 2	197053	Driver Assembly, Selector Magnet 1,17
181810	Relay 7,9	193276	Resistor, 750 Ohm 2	197054	Jumper, 3" Black 23
181846	Nameplate 13	193401	Plate, Mounting 14	197057	Cable w/Terminals 19
181879	Transformer, Power 12	193403	Plate, Mounting 3	197078	Plate, Mounting 7,8,13
181892	Sleeve, 9/64 ID x 1" Lg Insulating 23	193405	Nut, Speed 3,4,6,11,12,14, 15,17	197464	Diode 15
182182	Holder, Fuse 16	193410	Plate Assembly 1,3	198205	Cable w/Terminals 6,15
182193	Insulator 11	193415	Container, Electrical Service 2	198208	Board, Terminal 2
182284	Insulator, .015" Thk 12,17,18	193419	Cover 2	198209	Regenerator Assembly Signal 1,15
182501	Capacitor, 1500 MFD 17,18	193421	Cover 2	198214	Cover 2
182510	Cord, Power 23	193422	Board, Terminal 2	198248	Card, Circuit 6,15
182520	Rectifier 3	193423	Board, Terminal 3	198259	Jumper, 3" Black 23
182523	Clamp, 1-3/8" ID Mounting 12,17,18	193437	Plate, Assembly 1,3	198291	Bracket, Relay 7,9
182539	Connector, 15 Pt Receptacle Type 23	193451	Bell Assembly, Signal 1,15	198292	Cover, Relay 7,9
182540	Connector, 15 Pt Plug Type 7,23	193452	Cable w/Terminals 15	198293	Insulator, Terminal 7,9
182611	Fuse, 3/8 Amp SL-BL 17,18	193464	Plate, Mounting 6,15	198516	Plate, Mounting 5
182630	Card, Circuit 17	193465	Jumper, 3/4" Black 23	198649	Connector, 15 Pt Circuit Card 6,12,15,16,17
182631	Card, Circuit 17	193466	Jumper, 13" Green 23	198650	Key, Polarizing 16,17
182643	Terminal, Plug Type 7,8,9,22, 23	193479	Jumper, 12" Black 23	198831	Jumper, 8" Black 2,23
182644	Terminal, Receptacle Type 7,8,9,10,14,23	193485	Driver Assembly, Selector Magnet 1,17	199322	Connector, 6 Pt Receptacle Type 7,8,9,10,14
182647	Connector, 12 Pt Plug Type 23	194989	Jumper, 9" Black 23	199325	Jumper, 16" Yellow 7,9, 10,14
182648	Connector, 12 Pt Receptacle Type 9,23	194990	Screw, 10-32 Shoulder 2	199326	Jumper, 16" Purple 7,9, 14
182650	Connector, 6 Pt Plug Type 9	195153	Transformer 17,18	199350	Transformer Assembly, Copylight 1,14
182716	Connector, 9 Pt Plug Type 7,8	195242	Plate, Mounting 17	199352	Transformer 7,8,9,10,14
182726	Terminal, Receptacle Type 6	195243	Plate, Heat Sink 17	199360	Distribution Assembly, Power 1,7
182763	Resistor 2	195244	Cable w/Terminals 17	199393	Washer, Insulating 2
183111	Label 17,18	195245	Sleeve, 1/2 ID x 1-1/2" Lg Insulating 17,18	199394	Insulator 2
185676	Terminal, Plug Type 8,9	195863	Connector, 2 Pt Receptacle 23	199396	Jumper, 9" Black 23
185677	Terminal, Receptacle Type 8	195939	Cover 2	199442	Diode 2,5
185678	Plate, Identification 18	195940	Stud 2,4	302410	Knob 22,23
185683	Plate, Identification 7	197020	Board, Terminal 2	304673	Rack Assembly, Relay 1,22
185684	Plate, Identification 7,9, 10	197023	Container, Electrical Service 2,15	304681	Transformer 21
185685	Plate, Identification 7	197025	Stop 2, 4 to 10,13,16,18	304689	Plate, Clamp 2,4 to 10, 13,16,18
192007	Terminal, Tab Type 2.5 to 21,23	197027	Jumper, 9" Black 23	304922	Distribution Assembly, Power 1,7
		197028	Terminal 2	304924	Board, Terminal 2
		197029	Cable w/Terminals 7	304925	Board, Terminal 4
		197031	Connector, 3 Pt Receptacle 7,8,9,10,13	304927	Cable w/Terminals 22
		197032	Plate 2		
		197035	Control Assembly, Motor 1,19		



## NUMERICAL INDEX (Continued)

Part Number	Description and Page Number	Part Number	Description and Page Number	Part Number	Description and Page Number
304933	Cable Assembly 7	311484	Transformer Assembly, Copylight 1,14	323048	Cable w/Terminals 5
304990	Connector, 15 Pt Plug 22			323050	Rectifier Assembly 1,21
304993	Plate, Mounting 22	311995	Jumper, 9-1/2" Red 23	323056	Distributor Assembly, Power 1,10
305060	Cable w/Terminals 20	312325	Card, Circuit 16	323088	Plate Assembly, Relay 1,5
305061	Rectifier Assembly 1,20	312326	Cable w/Terminals 16	323577	Capacitor 12
305093	Plate Assembly, Terminal 1,22	312329	Bracket, Fuse 18	323578	Cable w/Terminals 12
305094	Bracket, Mounting 22	312333	Transformer 16	323580	Logic Assembly, Interface 1,12
305096	Plate, Terminal 22	312341	Diode 5		
305099	Cover, Insulating 14	312351	Driver Assembly, Selector Magnet 1,17	323581	Plate 12
305406	Plate Assembly 1,3	312352	Card, Circuit 17	323585	Card, Circuit 12
305411	Mounting Plate, Relay 4	312353	Cable w/Terminals 17	323586	Card, Circuit 12
305417	Board Assembly, Terminal 1,4	312382	Chassis 10,13	323606	Diode 5
		312391	Plate, Mounting 16	323609	Card, EC609 Circuit 15
305421	Rack Assembly, Relay 1,22	312392	Bracket 16	326635	Network, Spark Suppression 2
305427	Bracket, Connector Mounting 22	312401	Diode 5		
		312911	Diode 5	327106	Resistor w/Terminals 2
305440	Plate Assembly, Relay 1,5	315627	Cable w/Terminals 10	328365	Resistor w/Terminals 470 Ohm 2
305441	Cable w/Terminals 5	315647	Cable w/Terminals 10		
305446	Regenerator Assembly, Signal 1,16	315999	Bracket 18	328366	Diode w/Terminals 2
305447	Magnet Driver, Selector 1, 18	319257	Distributor Assembly, Power 1,9	328387	Jumper, 3" Black 6
		319258	Plate, Mounting 9	330781	Shield, Transformer 17,18
305458	Cable w/Terminals 18	319268	Cable w/Terminals 9	330782	Shield, Transformer 17,18
305459	Card, Circuit 18	319998	Capacitor 12	330792	Transformer 17,18
305462	Plate, Mounting 18	320265	Jumper, 24" Green 23	333480	Rectifier Assembly 2
305466	Plate 18	320410	Terminal, Spade Type 9,11, 22,23	334763	Cable Assembly 9
305538	Cable w/Terminals 14			336100	Cable w/Terminals 6
305762	Cover 2,4	320416	Terminal, Ring Type 17,18	336102	Card, Circuit 6
307219	Jumper, 6" Black 23	320418	Terminal, Ring Type 7 to 14,22,23	336103	Alarm Assembly, Buzzer 1, 6
308439	Rectifier 18			336108	Distribution Assembly, Power 1,9
308440	Strip, Terminal 18	320420	Terminal, Ring Type 17,18, 23	336119	Insulator 6
310274	Transformer 20			336379	Adapter 2
310278	Rectifier Assembly 20	320442	Resistor, 240 Ohm 2	342113	Relay 2
310654	Fuse, .15 AMP 12	320452	Transformer Assembly, Copylight 1,14	343470	Label 7,8,9,10
310707	Rectifier Assembly 1,20			343990	Cable Assembly 6
311076	Distributor Assembly, Power 1,8	323013	Distribution Assembly, Power 1,13	343992	Plate 6
				344252	Plate Assembly, Relay 1,6
311077	Cable Assembly 8	323029	Cable w/Terminals 21		
311406	Terminal, Receptacle Type 17,18	323047	Cable w/Terminals 10		

35 ELECTRICAL SERVICE UNIT (LESU)

WALL MOUNTED KSR/RO

PARTS

FIGURE	CONTENTS	PAGE
1	Container and Components	2
2	178518 Motor Control Assembly	3
3	195784 Constant Current Selector Magnet Driver Assembly	4
4	199982 Line Shunt Relay Assembly with Auxiliary Power Supply and the 321880 Line Shunt Relay Assembly	5
5	182630 Circuit Card	6
6	199878 Circuit Card	6
	Numerical Index	7

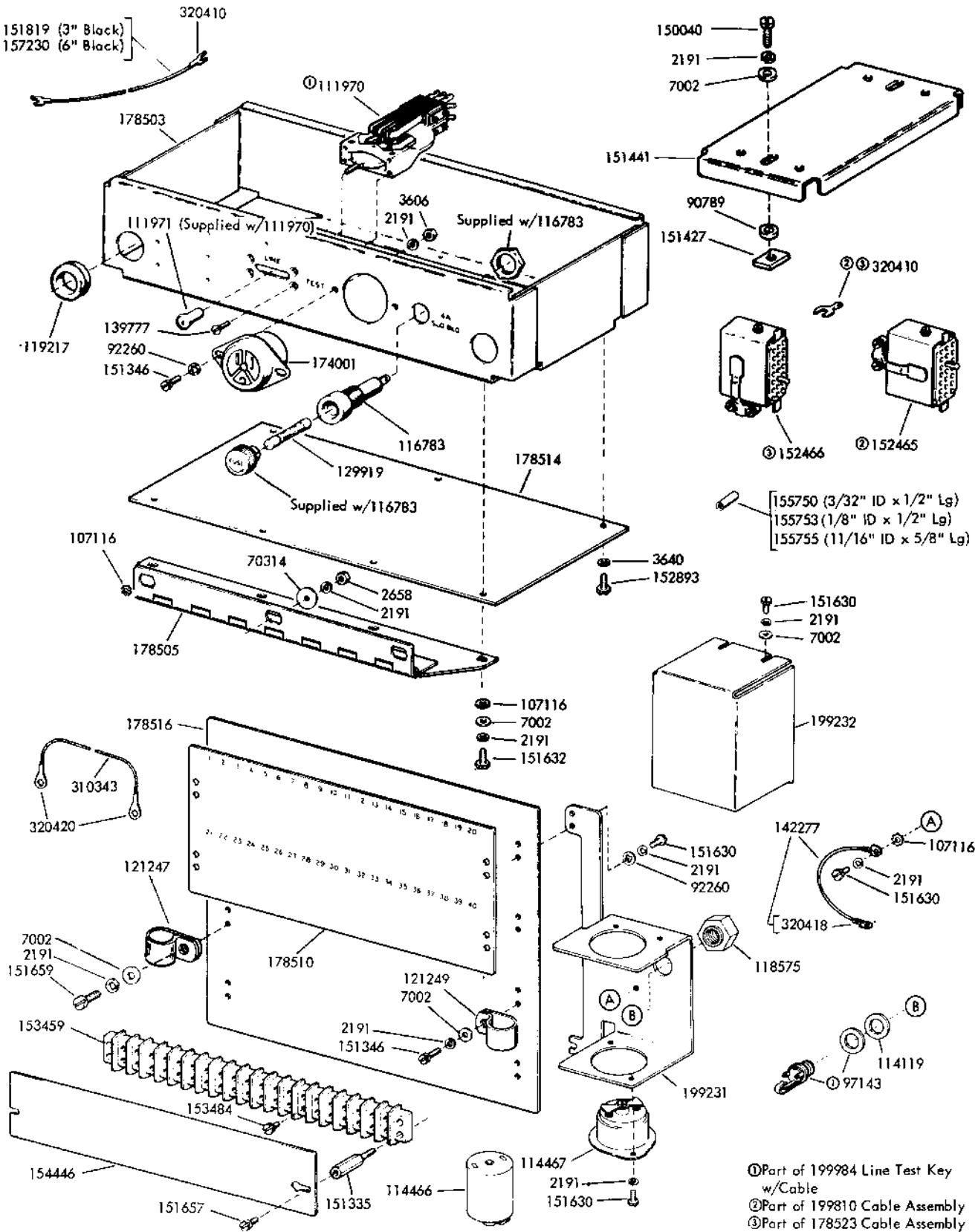
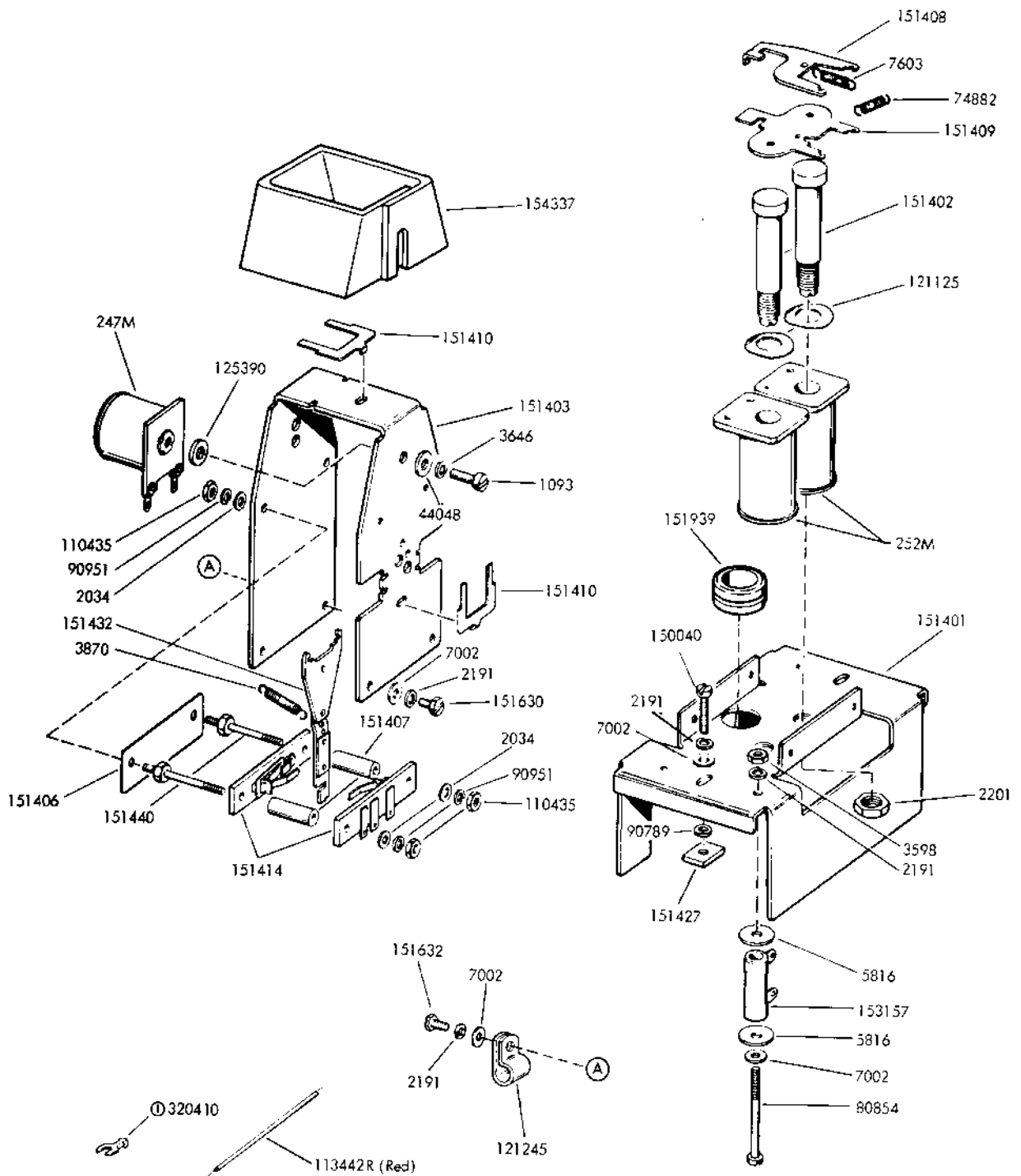

FIGURE 1. CONTAINER AND COMPONENTS



Ⓢ 178519 Cable

FIGURE 2. 178518 MOTOR CONTROL ASSEMBLY

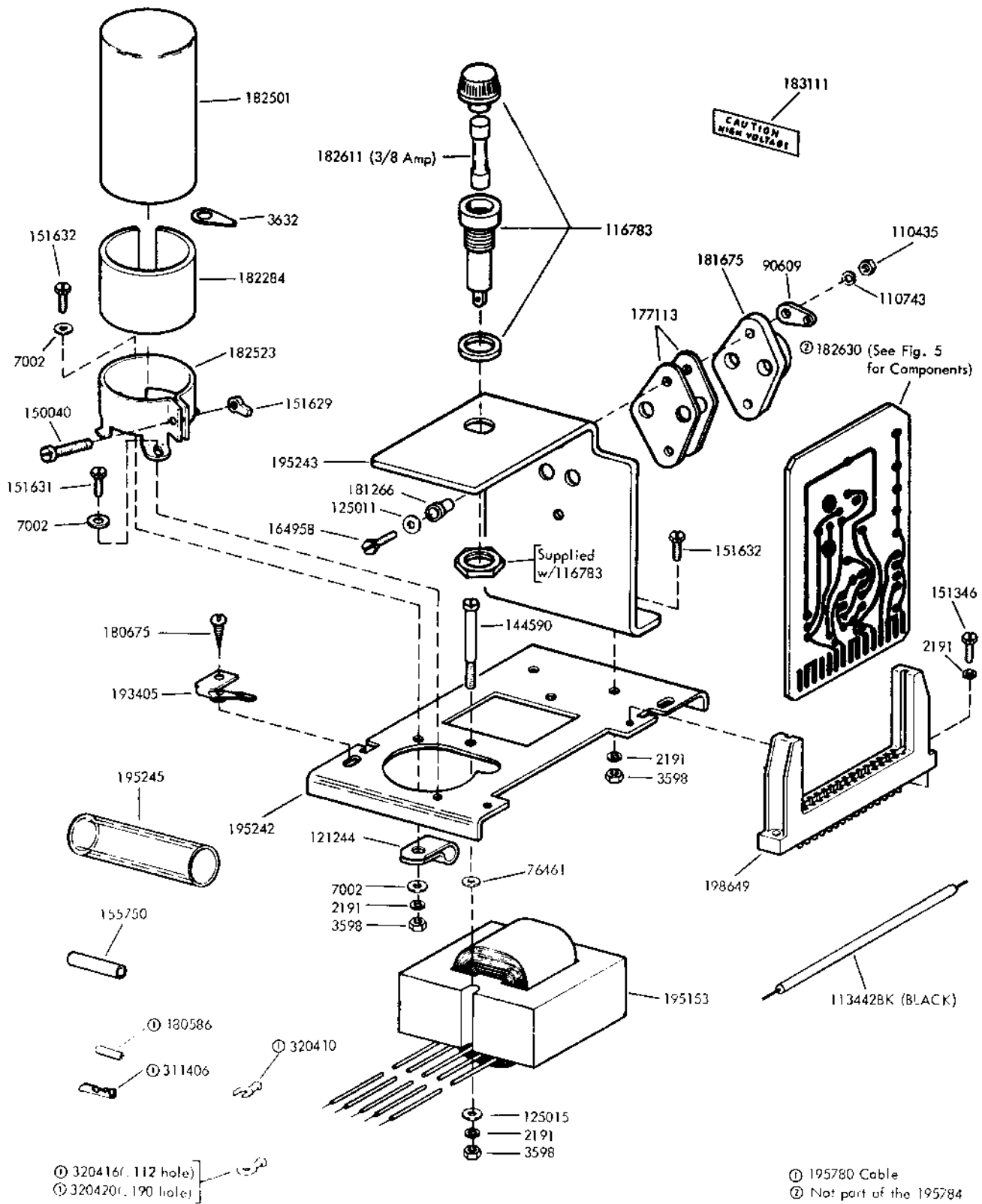

FIGURE 3. 195784 CONSTANT CURRENT SELECTOR MAGNET DRIVER ASSEMBLY

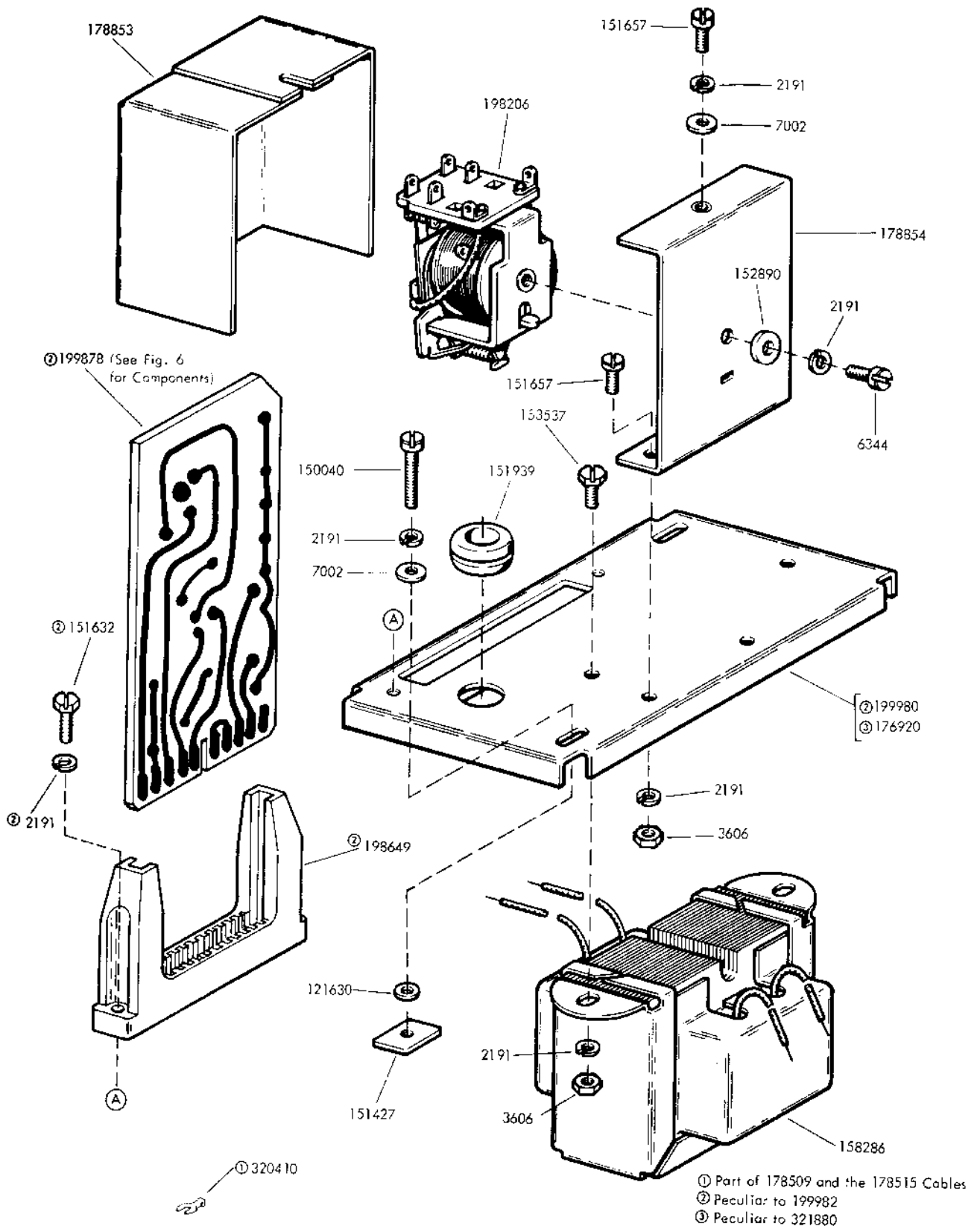
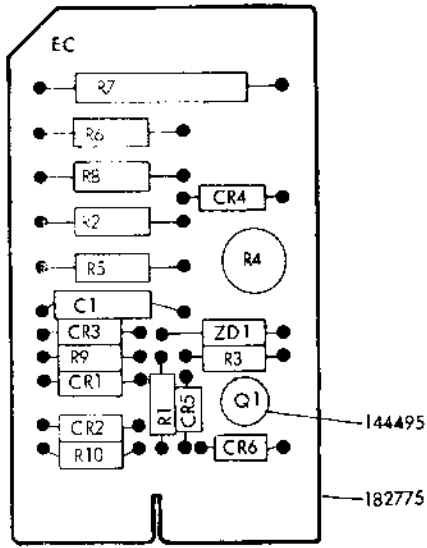
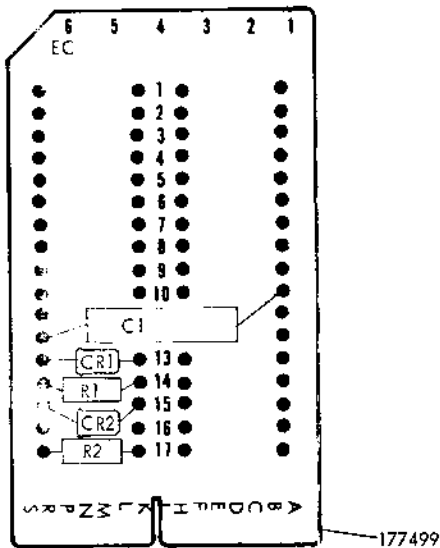

FIGURE 4. 199982 LINE SHUNT RELAY ASSEMBLY WITH AUXILIARY POWER SUPPLY AND THE 321880 LINE SHUNT RELAY ASSEMBLY



Reference Designation	Part Number	Total Qty.	Description
R1	182779	1	Resistor 420 Ohms
R2	181669	1	Resistor 330 Ohms
R3	182778	1	Resistor .82 Ohms
R4	182773	1	Potentiometer
R5	181717	1	Resistor 8 Ohms
R6	182770	1	Resistor 270 Ohms
R7	182772	1	Resistor 14 Ohms
R8	182627	1	Resistor 390 Ohms
R9	182776	1	Resistor 150 Ohms
R10	182777	1	Resistor 680 Ohms
CR1 & 2	182520	2	Rectifier
CR3 & 4	181619	2	Diode 1N482
CR5	178844	1	Varistor 100A
CR6	199442	1	Diode 1N270
ZD1	182774	1	Diode, Zener 4.7V
C1	182628	1	Capacitor 10 MFD
Q1	181671	1	Transistor
TP	144495	1	Pad, Transistor

FIGURE 5. 182630 CIRCUIT CARD



Reference Designation	Part Number	Total Qty.	Description
R1	198264	1	Resistor 910 Ohm
R2	181669	1	Resistor 330 Ohm
C1	198266	1	Capacitor 150 MFD
CR1 & 2	182520	2	Diode 1N2611

FIGURE 6. 199878 CIRCUIT CARD

## NUMERICAL INDEX

Part Number	Description and Page Number	Part Number	Description and Page Number	Part Number	Description and Page Number
247M	Coil, Magnet 3	151402	Core 3	178854	Bracket, Relay 5
252M	Coil, Magnet 3	151403	Frame 3	180586	Sleeve, 5/32 ID x 21/32" Lg Insulating 4
1093	Screw, 8-32 x 7/16 Fil 3	151406	Plate, Insulating 3	180675	Screw, #6 Self-Tapping 4
2034	Washer, Flat 3	151407	Collar, Spacing 3	181266	Bushing, Insulating 4
2191	Washer, Lock 2,3,4,5	151408	Lever 3	181619	Diode 6
2201	Nut, 5/16-32 Hex 3	151409	Armature 3	181669	Resistor, 330 Ohm 6
2658	Nut, 6-32 Hex 2	151410	Clip, Retaining 3	181671	Transistor 6
3598	Nut, 6-40 Hex 3,4	151414	Switch, Sensitive 3	181675	Transistor, Power 4
3606	Nut, 6-40 Hex 2,5	151427	Plate, Clamp 2,3,5	181717	Resistor, 8 Ohm 6
3632	Terminal 4	151432	Armature 3	182284	Insulator, .015" Thk 4
3640	Washer, Lock 2	151440	Stud 3	182501	Capacitor, 1,500 MFD 4
3646	Washer, Lock 3	151441	Plate, 2-3/4 Blank 2	182520	Rectifier 6
3870	Spring 3	151629	Nut, 6-40 Lug 4	182523	Clamp, 1-3/8" ID Mounting 4
5816	Washer, Insulating 3	151630	Screw, 6-40 x 1/4 Hex 2,3	182611	Fuse 4
6344	Screw, 6-32 x 11/32 Hex 5	151631	Screw, 6-40 x 5/16 Hex 4	182627	Resistor, 390 Ohm 6
7002	Washer, Flat 2,3,4,5	151632	Screw, 6-40 x 3/8 Hex 2,3,4,5	182628	Capacitor, 10 MFD 6
7603	Spring 3	151657	Screw, 6-40 x 1/4 Fil 2,5	182630	Card, Circuit 1,4,6
44048	Washer, Flat 3	151659	Screw, 6-40 x 1/2 Fil 2	182770	Resistor, 270 Ohm 6
70314	Washer, Flat 2	151819	Jumper, 3" Black 2	182772	Resistor, 14 Ohm 6
74882	Spring 3	151939	Grammet, Rubber 3,5	182773	Potentiometer 6
76461	Washer, Flat 4	152465	Connector, 20 Pt Receptacle 2	182774	Diode 6
80854	Screw, 6-40 x 1-7/16 Fil 3	152466	Connector, 21 Pt Receptacle 2	182775	Card, Circuit 6
90609	Terminal 4	152890	Washer, Flat 5	182776	Resistor, 150 Ohm 6
90789	Washer, Flat 2,3	152893	Screw, 4-40 x 1/4 Hex 2	182777	Resistor, 680 Ohm 6
90951	Washer, Lock 3	152899	Screw, 4-40 x 1/4 Hex 2	182778	Resistor, .82 Ohm 6
92260	Washer, Lock 2	153157	Resistor, 400 Ohm 3	182779	Resistor, 420 Ohm 6
97143	Jack 2	153459	Block, Terminal 2	183111	Shim, .004" Thk 4
107116	Washer, Lock 2	153484	Screw, 6-32 Spl 2	193405	Nut, Speed 4
110435	Nut, 4-40 Hex 3,4	153537	Screw, 6-40 x 9/32 Hex 5	195153	Transformer 4
110743	Washer, Lock 4	154337	Cover 3	195242	Plate, Mounting 4
111970	Key, Line Test 2	154446	Cover 2	195243	Plate, Heat Sink 4
111971	Knob 2	155750	Sleeve, 3/32 ID x 1/2" Lg Insulating 2,4	195245	Sleeve, 1/2 ID x 1-1/2" Lg Insulating 4
113442BK	Jumper, 2-1/2" Black 4	155753	Sleeve, 1/8 ID x 1/2" Lg Insulating 2	195780	Cable w/Terminals 4
113442R	Jumper, 2-1/2" Red 3	155755	Sleeve, 11/64 ID x 5/8" Lg Insulating 2	195784	Driver Assembly 1,4
114119	Washer, Insulating 2	157230	Jumper, 6" Black 2	198206	Relay 5
114466	Connector, 3 Pt Receptacle 2	158286	Transformer 5	198264	Resistor, 910 Ohm 6
114467	Connector, 3 Pt Plug 2	164958	Screw, 4-40 x 1/2 Hex 4	198266	Capacitor, 150 MFD 6
116783	Holder, Fuse 2,4	174001	Connector, 3 Pt Receptacle 2	198649	Connector, 15 Pt Circuit Card 4,5
118575	Nut, 3/8-32 Insulating 2	176920	Plate, Mounting 5	199231	Bracket, Connector Mounting 2
119217	Grammet, Rubber 2	177113	Insulator 4	199232	Cover 2
121125	Washer, Spring 3	177499	Card, Circuit 6	199442	Diode 6
121244	Clamp, 1/4 ID Cable 4	178503	Base 2	199810	Cable Assembly 2
121245	Clamp, 5/16 ID Cable 3	178505	Hinge 2	199878	Card, Circuit 1,5,6
121247	Clamp, 7/16 ID Cable 2	178509	Cable w/Terminals 5	199980	Plate, Mounting 5
121249	Clamp, 5/8 ID Cable 2	178510	Insulator, Terminal 2	199982	Relay Assembly, Line Shunt 1,5
121630	Washer, Flat 5	178514	Plate, Bottom 2	199984	Key, Line Test 2
125011	Washer, Flat 4	178515	Cable w/Terminals 5	310343	Jumper, 8-1/2" Green 2
125015	Washer, Flat 4	178516	Plate w/Studs 2	311406	Terminal, Receptacle Type 4
125390	Washer, Flat 3	178518	Control Assembly, Motor 1,3	320410	Terminal, Space Type 2,3,4,5
129919	Fuse, 5L-BL 4 Amp 2	178519	Cable w/Terminals 3	320416	Terminal, Ring Type 4
139777	Screw, 3-56 x 1/4 Flat 2	178523	Cable Assembly 2	320418	Terminal, Ring Type 2
142277	Cable w/Terminals 2	178844	Varistor 6	320420	Terminal, Ring Type 2,4
144495	Pad, Transistor Mounting 6	178853	Cover, Relay 5	321880	Relay Assembly 1,5
144590	Screw, 6-40 x 1-3/8 Fil 4				
150040	Screw, 6-40 x 5/8 Fil 2,3,4,5				
151335	Stud 2				
151346	Screw, 6-40 x 3/8 Fil 2,4				
151401	Base 3				



35 CALL CONTROL UNIT (LCCU)

PARTS

FIGURE	CONTENTS	PAGE	FIGURE	CONTENTS	PAGE
1	Basic Components	2	15	193489 and 195926 Modification Kits to Provide Rotary Dial	14
2	Basic Components (Continued)	3	16	186602, 186603, 193488 and 195927 Dial Modifications	15
3	Basic Components (Continued)	4	17	193486 and 195924 Dial Modifications	16
4	Basic Components (Continued)	5	18	199409 Modification Kit to Provide Fusing in the Primary of the Call Control Low Voltage Transformer	17
5	Basic Components (Continued)	6	19	319274 and 320489 Modification Kits to Add Alarm Lamps With Release Switches	18
6	182090 and 182092 Dial Assemblies	7	20	Signal Line Break Detection and Indication Features	19
7	182091 and 182093 Dial Assemblies	8	21	186627 Set Interface Logic Assembly	20
8	Receive-Only Lamp and Key Bracket	9		Numerical Index	21
9	Pilot Plate Assemblies	9			
10	182695 Selector Magnet Driver Assembly	10			
11	304995 Line Relay Mounting Assembly	11			
12	Cable Components	12			
13	Key Assemblies	13			
14	186601 Modification Kit to Provide a Twelve (12) Button Touch-Tone Dialer	14			

PAINT FINISH COLOR CODE CHART			
COLOR	Finish Suffix		
	Smooth Finish	Textured Vinyl	Smooth Vinyl
Charcoal Gray	BZ		HA
Dark Covert Gray	FC		
Light Gray			HB
Light Olive Gray	EW		HF
Gray Green	BK	GA	

The double asterisk(\*\*) denotes a painted part.  
 Suffix to be applied following the part number.

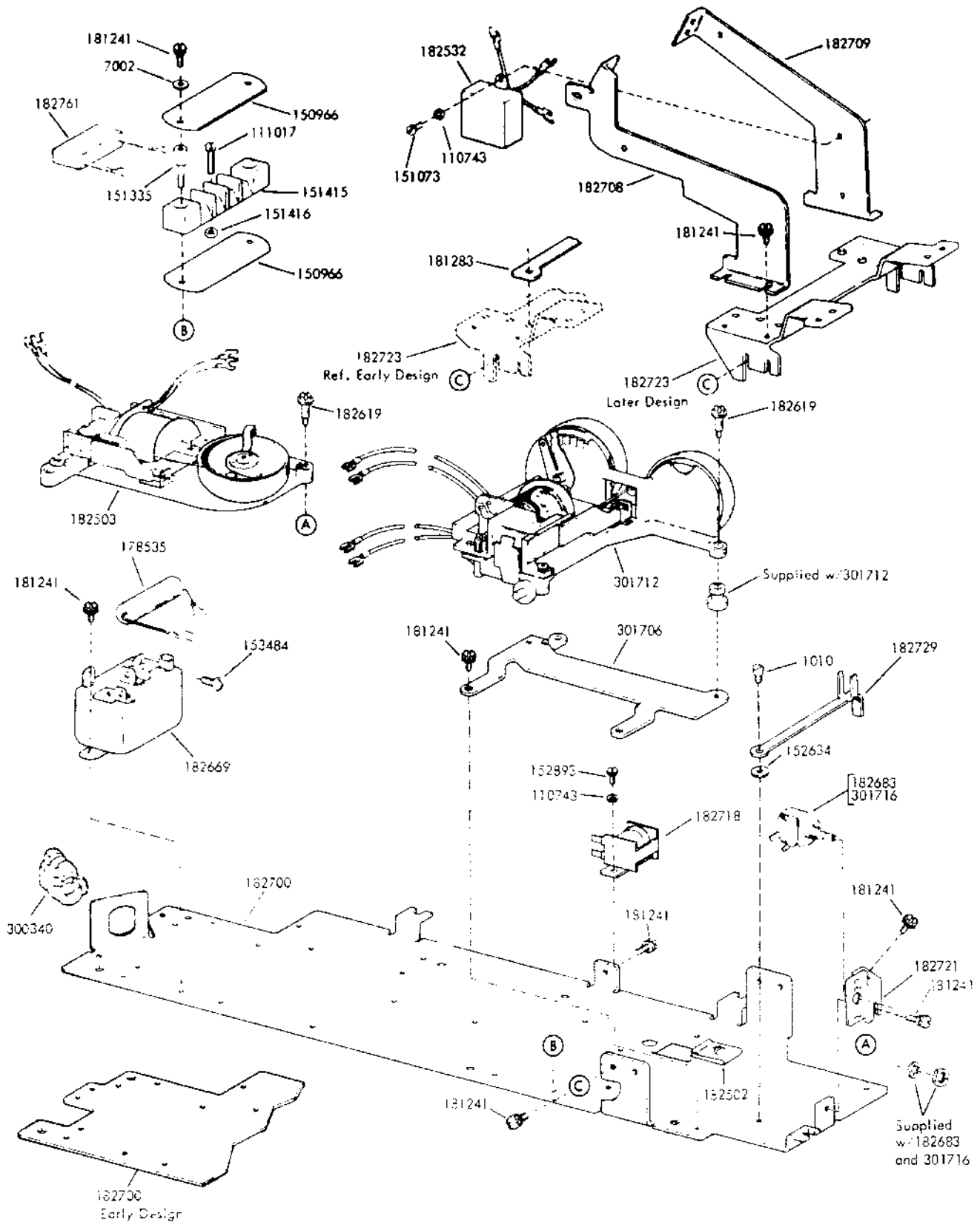

FIGURE 1 BASIC COMPONENTS

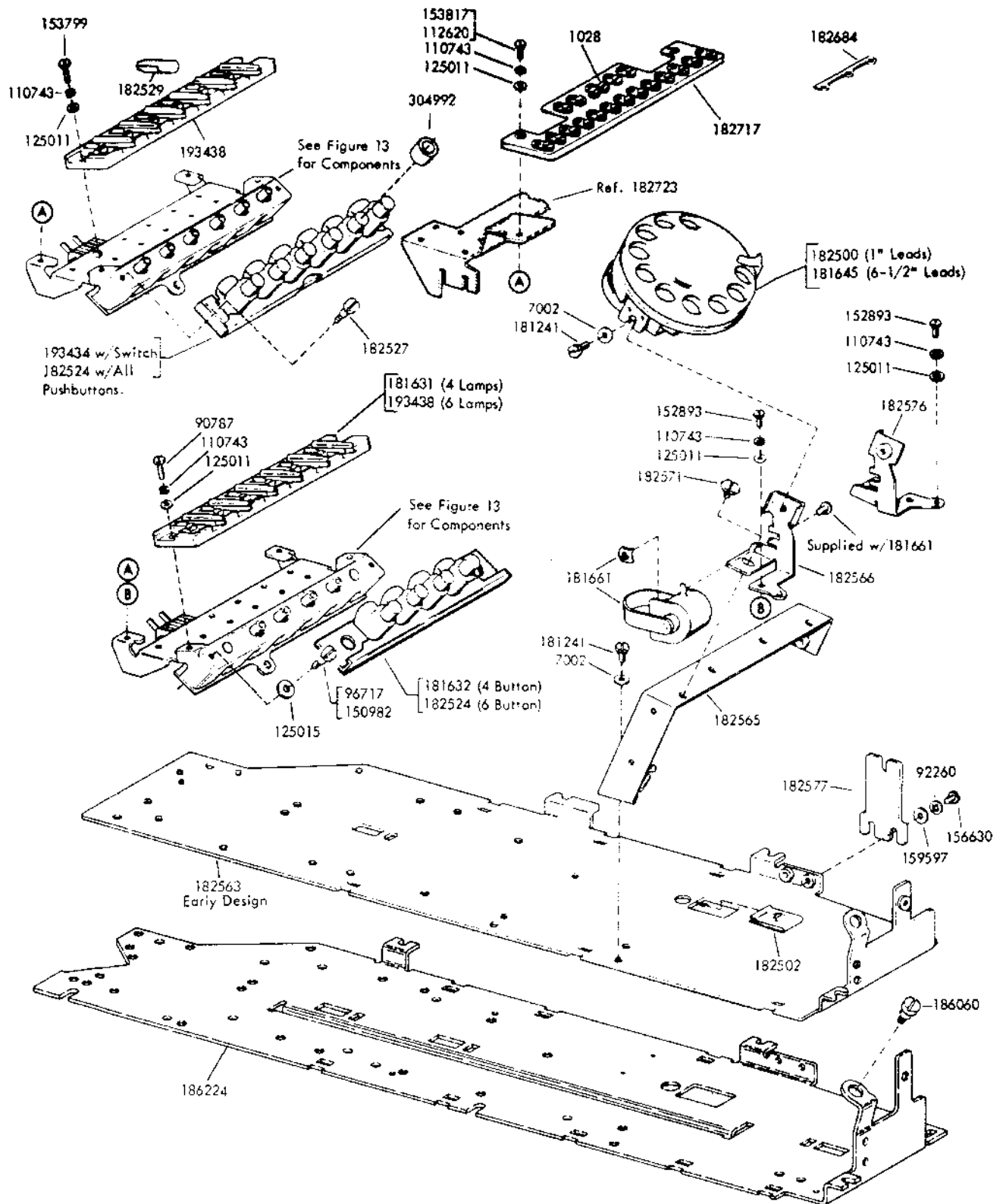

FIGURE 2. BASIC COMPONENTS (Continued)

FUSE CHART				
Location	Fuse	Nameplate	Description	Notes
A	162360	185688	.8A SL-BL	
	117176	185679	.5A SL-BL	Used w/181879 Trnsf.
B	117176	185679	.5A SL-BL	w/Data Set
C	161136	185686	6.25A SL-BL	
	129919	185684	4A SL-BL	RO Sets Only

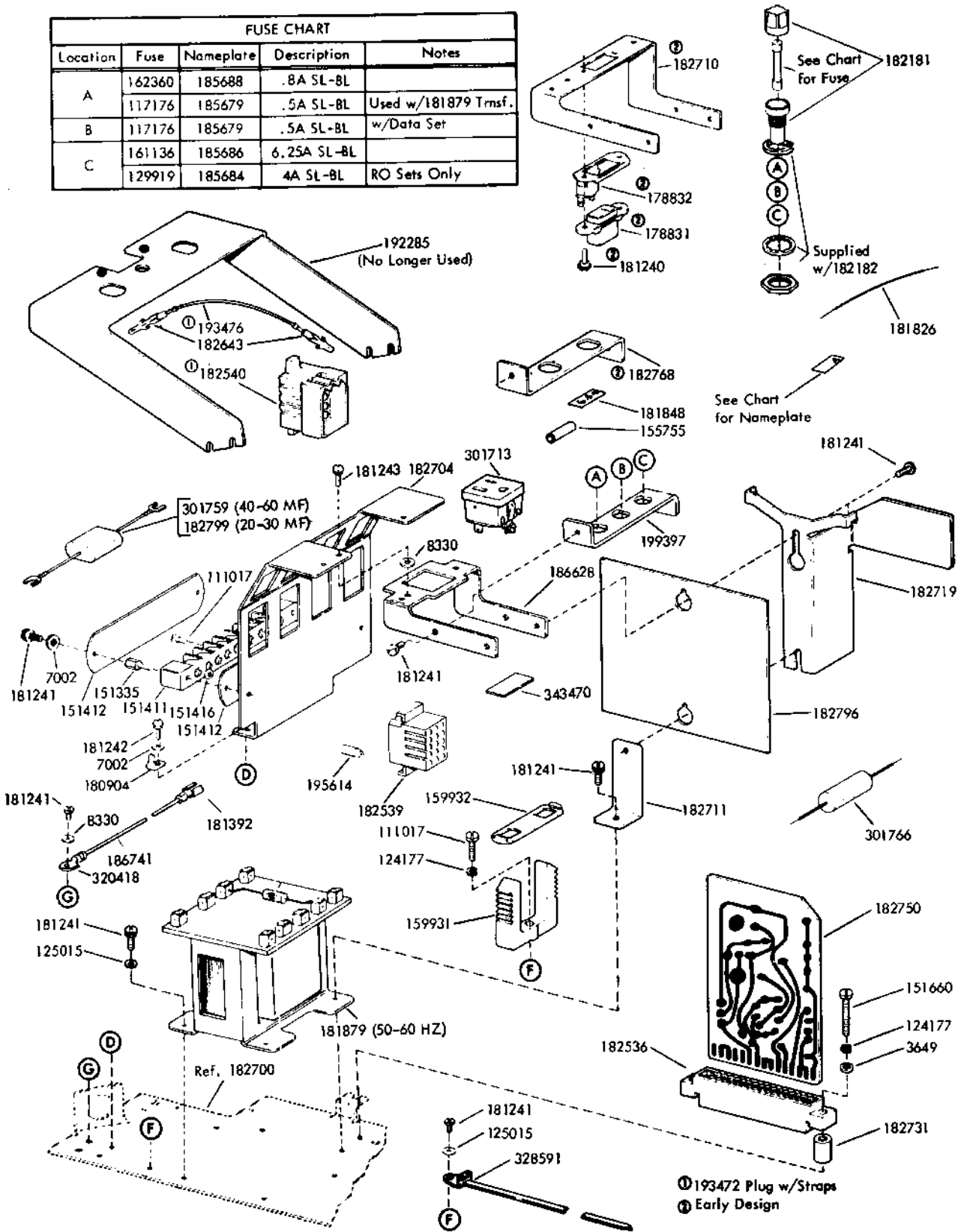

FIGURE 3. BASIC COMPONENTS (Continued)

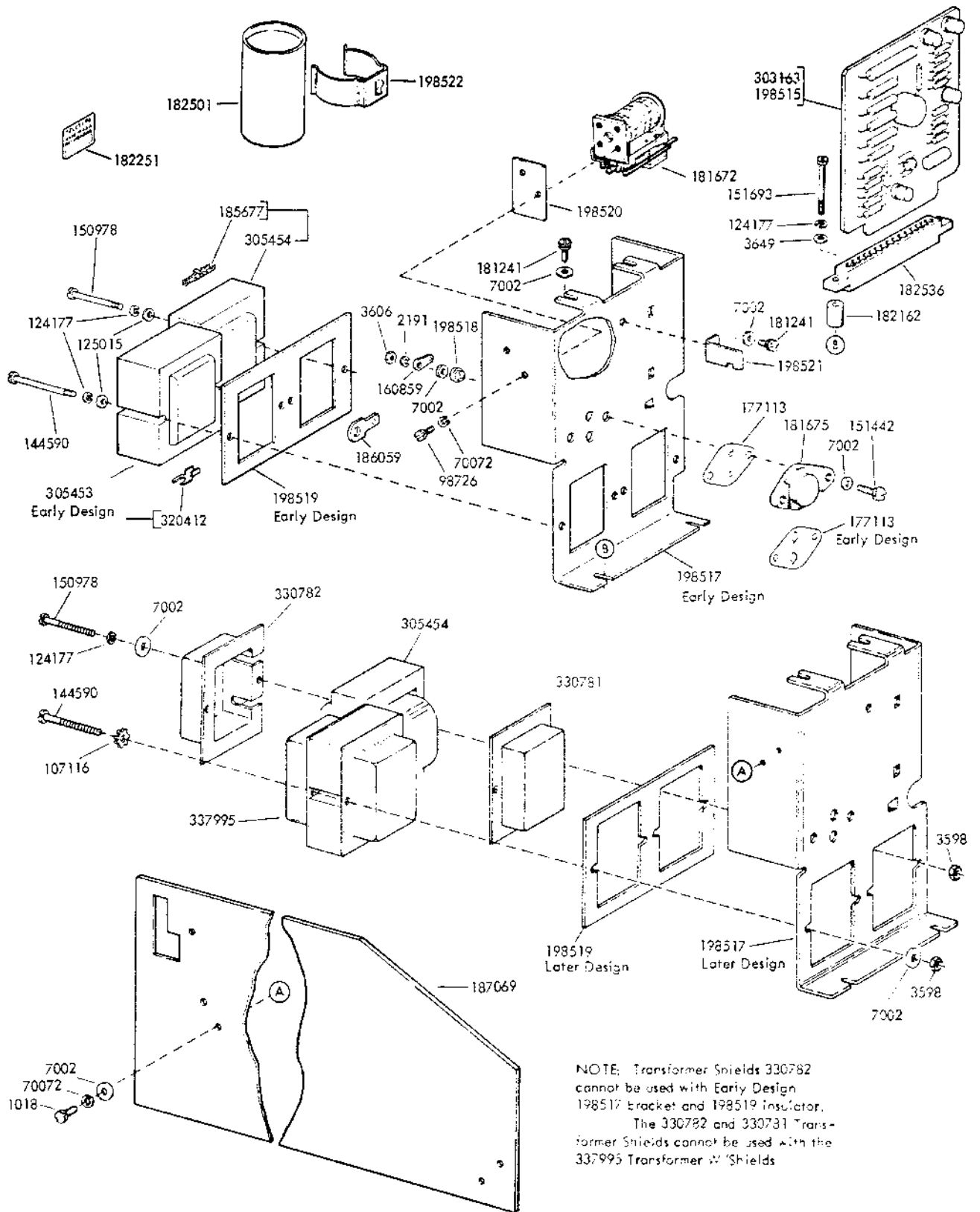

FIGURE 4. BASIC COMPONENTS (Continued)

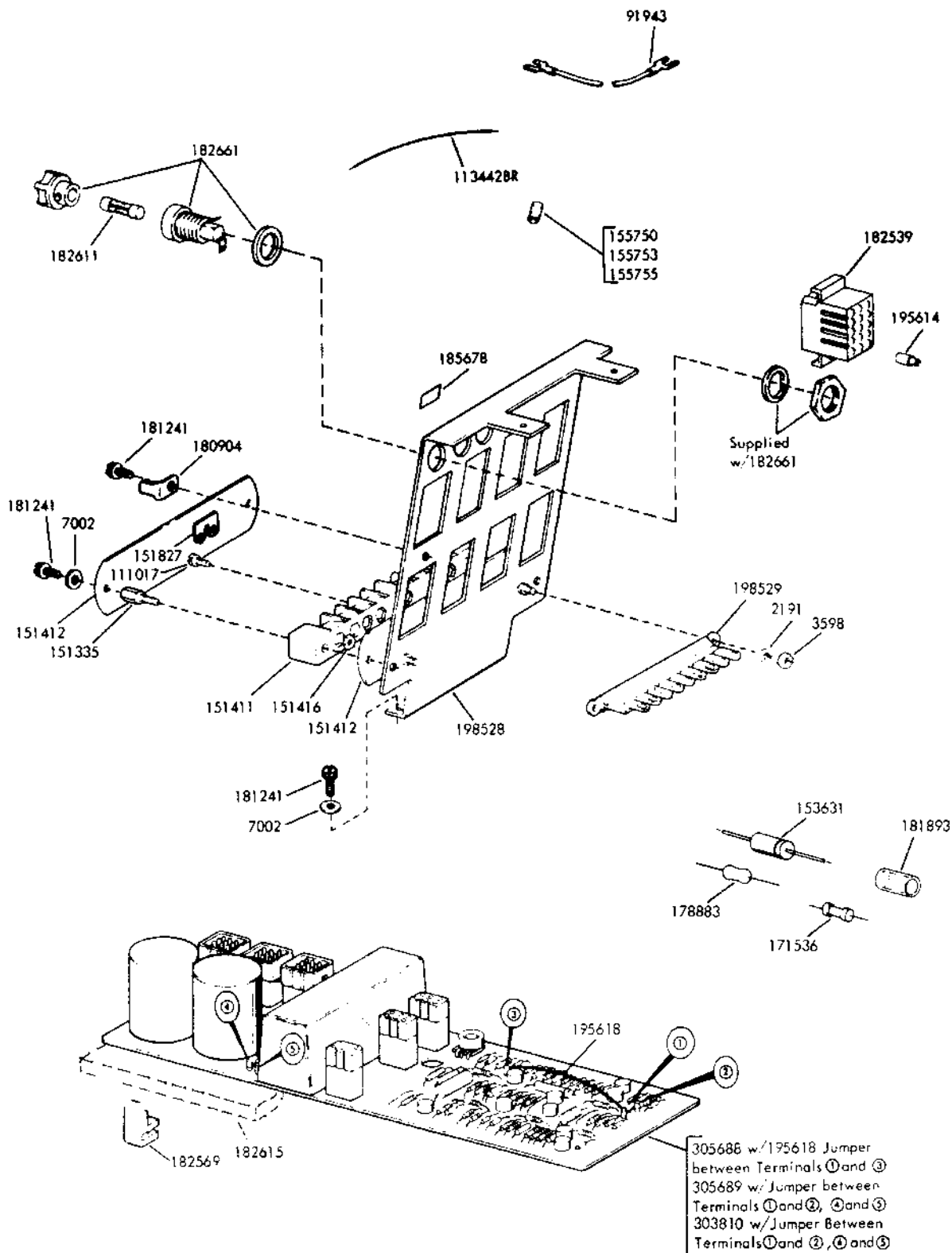
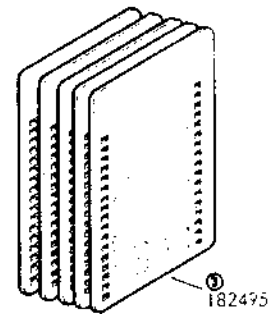
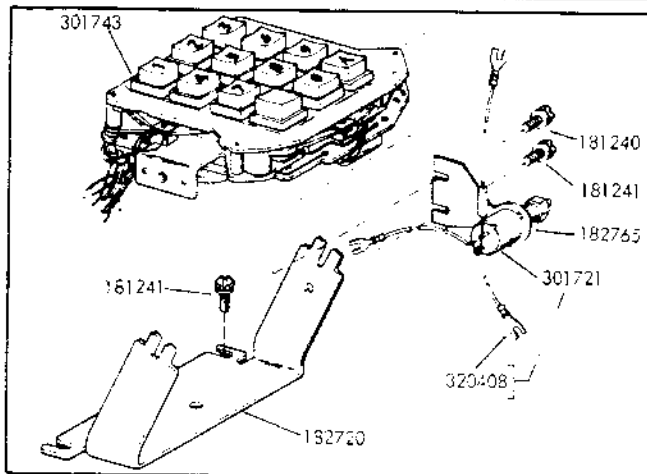
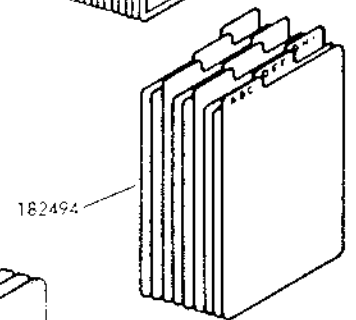
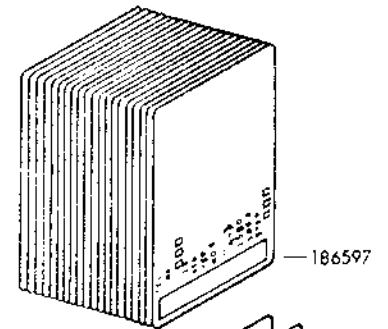
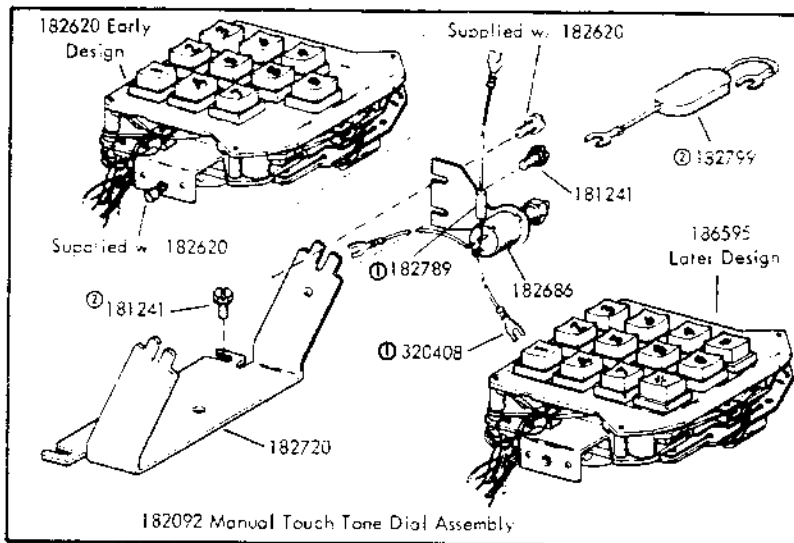
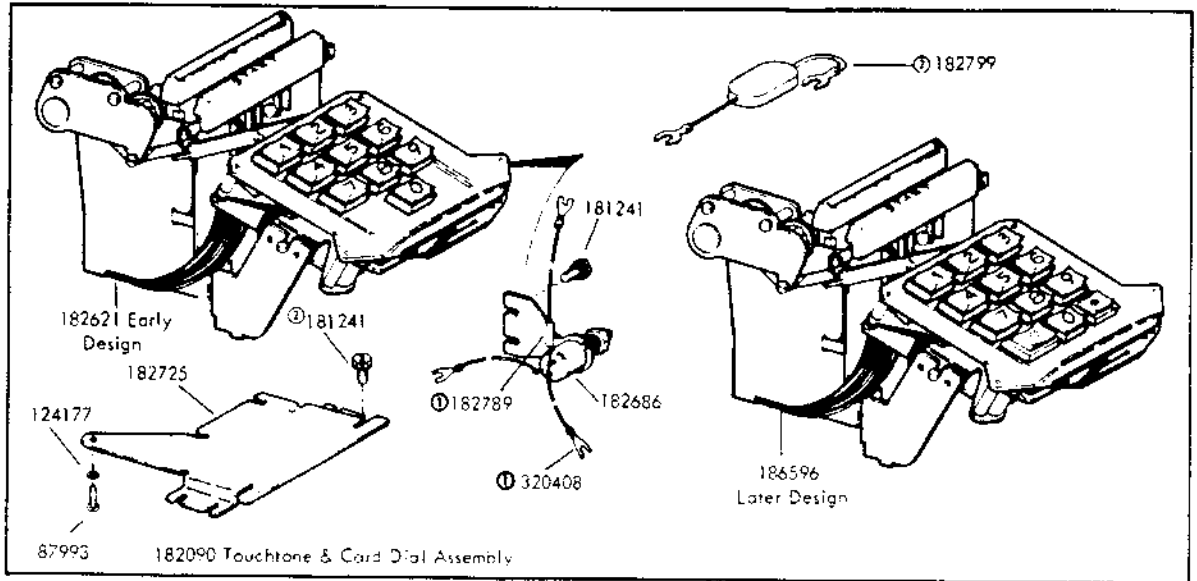

FIGURE 5. BASIC COMPONENTS (Continued)



- ① Supplied w/182686
- ② Not Part of Dial Assembly
- ③ Replaced by 186597

FIGURE 6. 182090 AND 182092 DIAL ASSEMBLIES

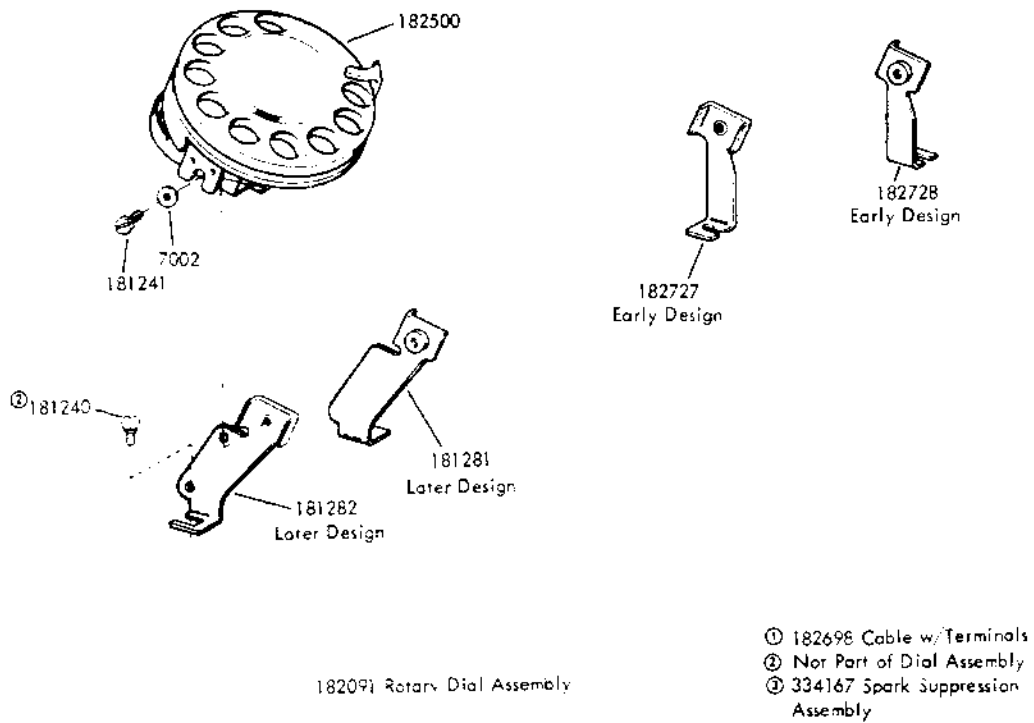
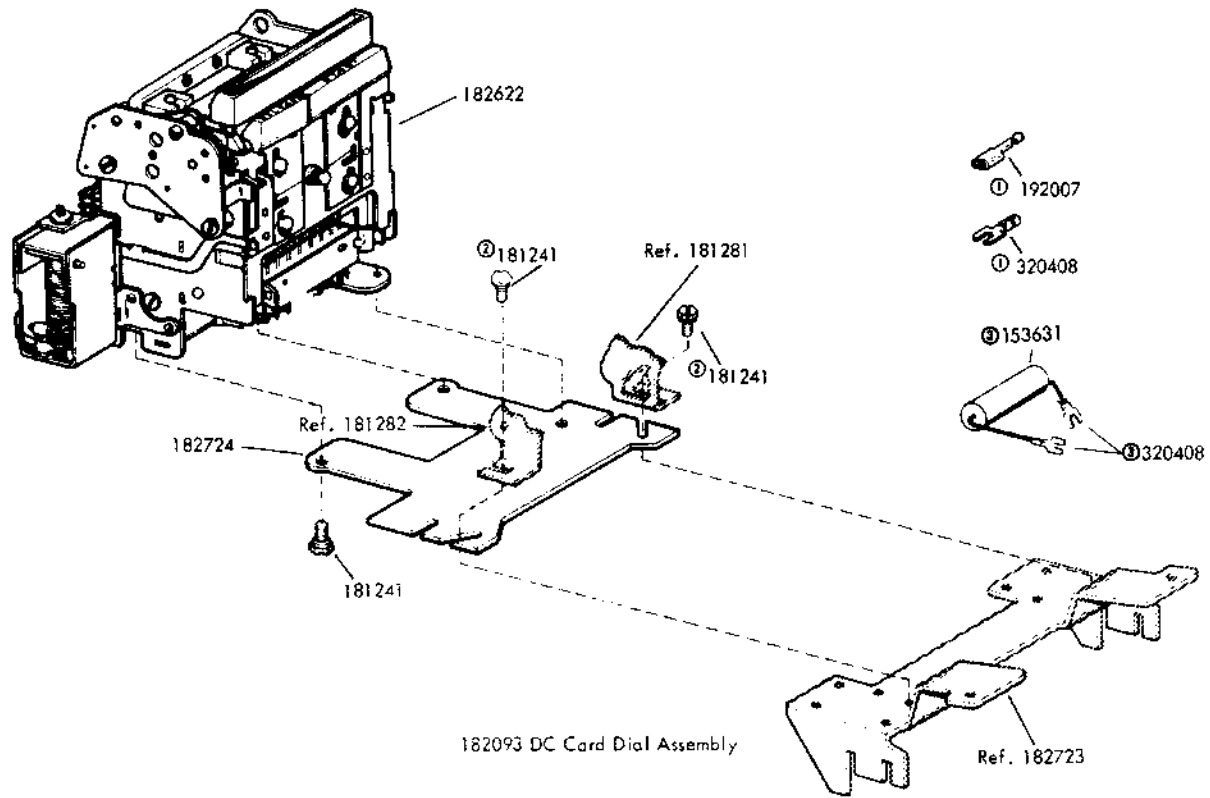

FIGURE 7. 182091 AND 182093 DIAL ASSEMBLIES



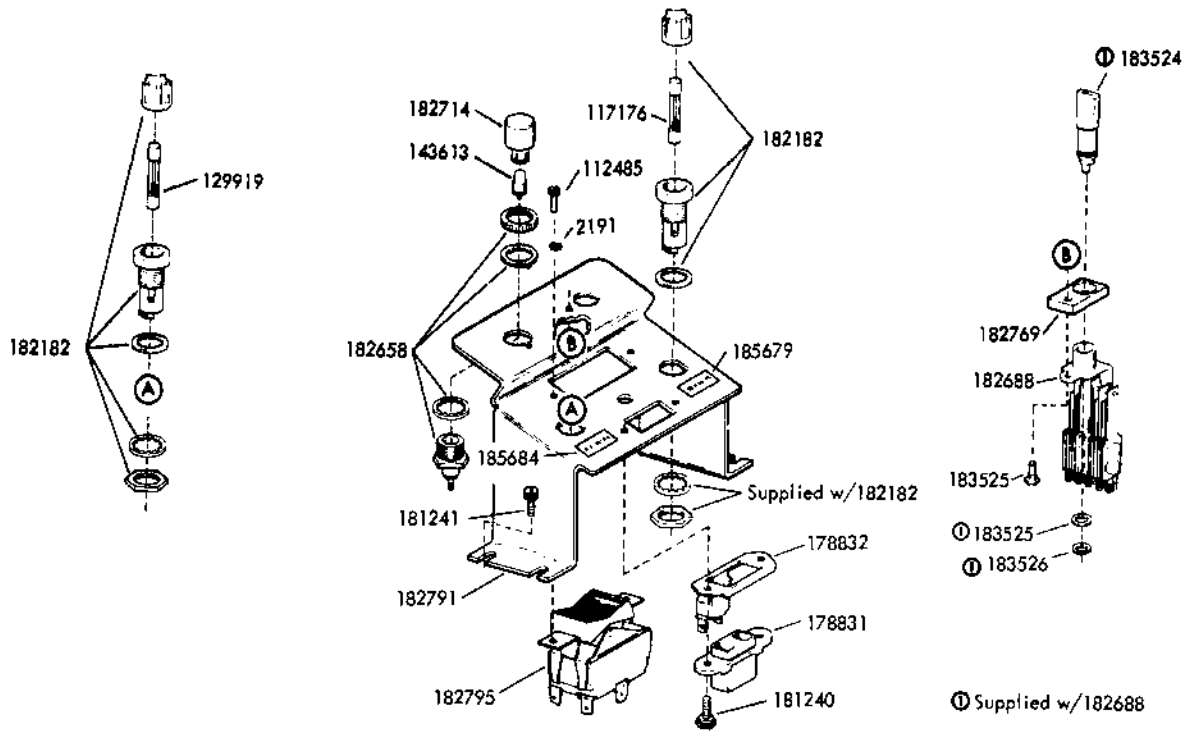

FIGURE 8. RECEIVE-ONLY LAMP AND KEY BRACKET

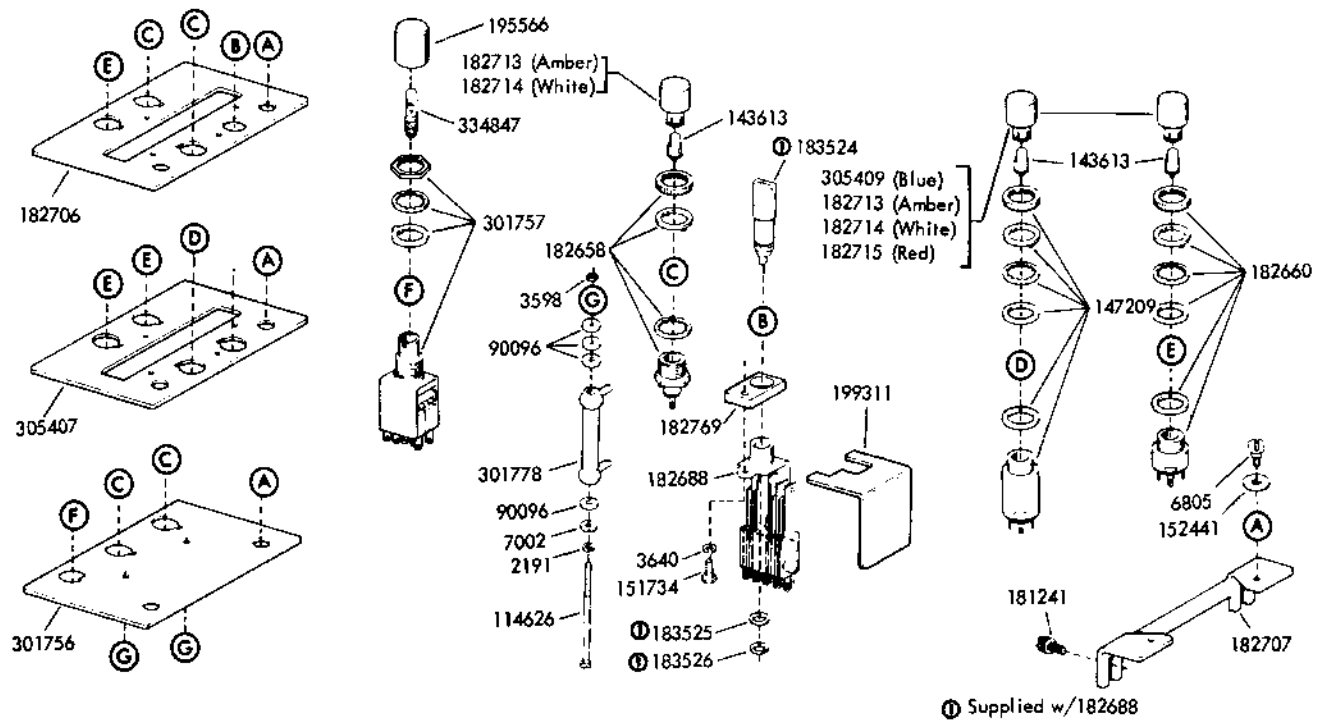

FIGURE 9. PILOT PLATE ASSEMBLIES

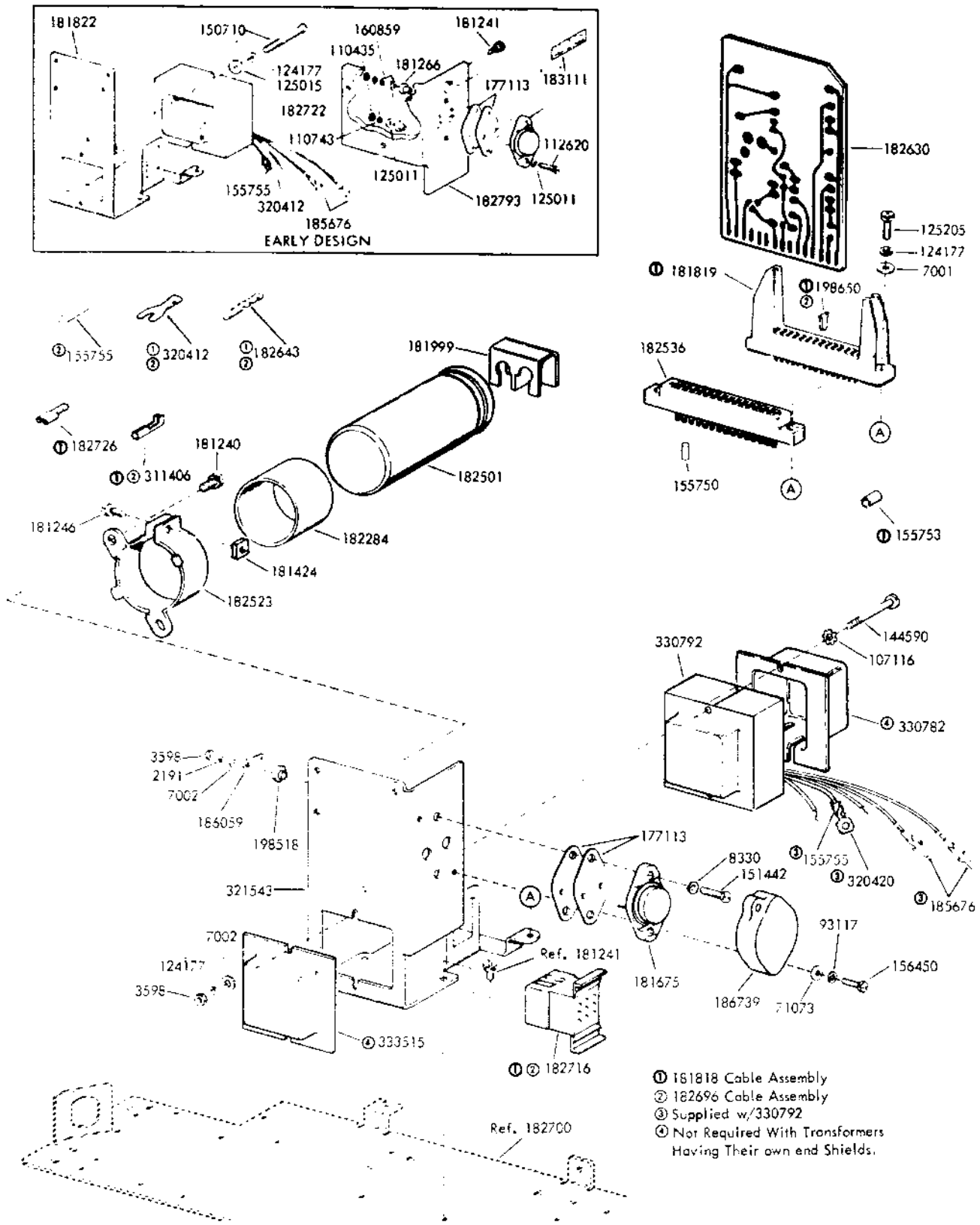

FIGURE 10. 182695 SELECTOR MAGNET DRIVER ASSEMBLY

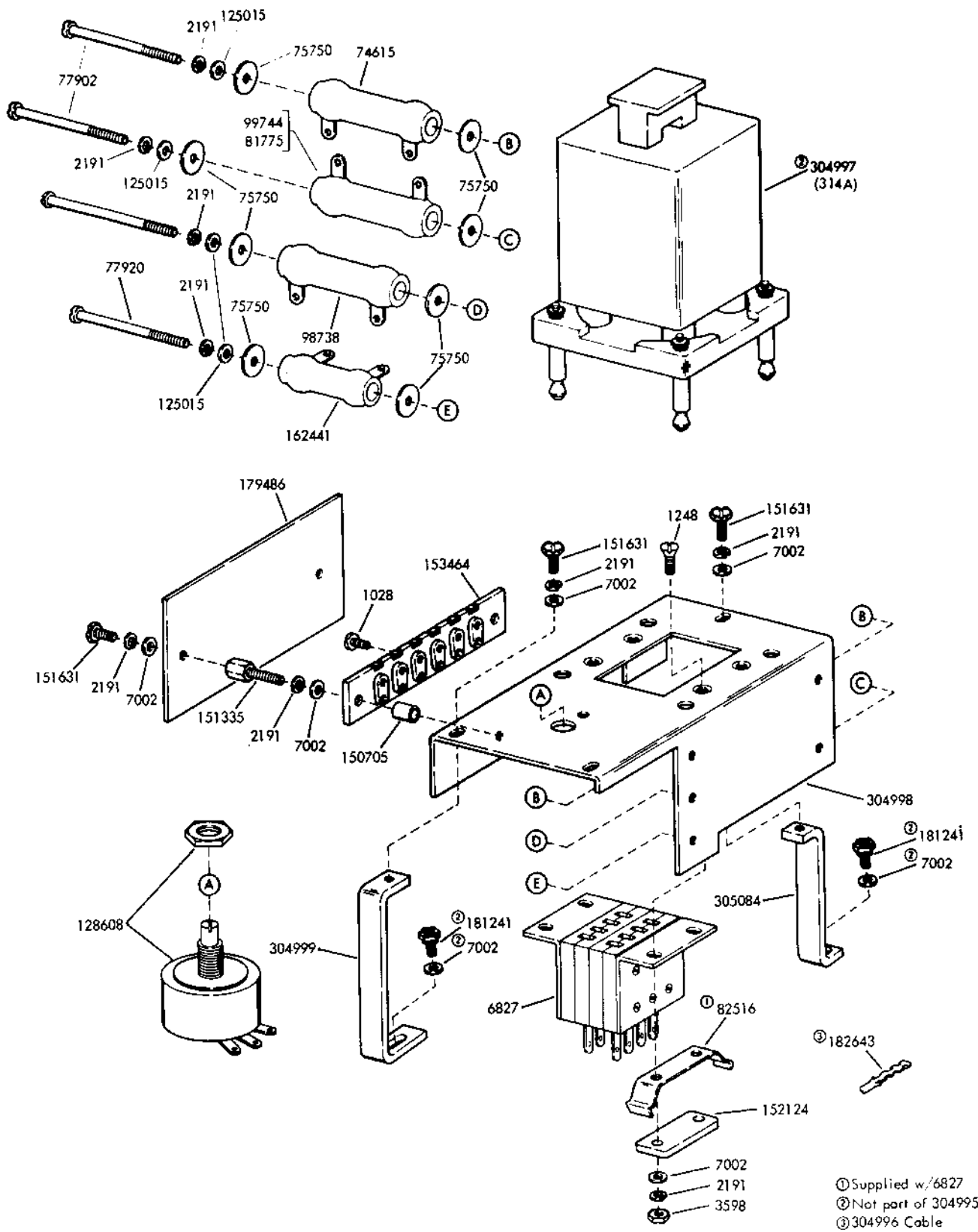
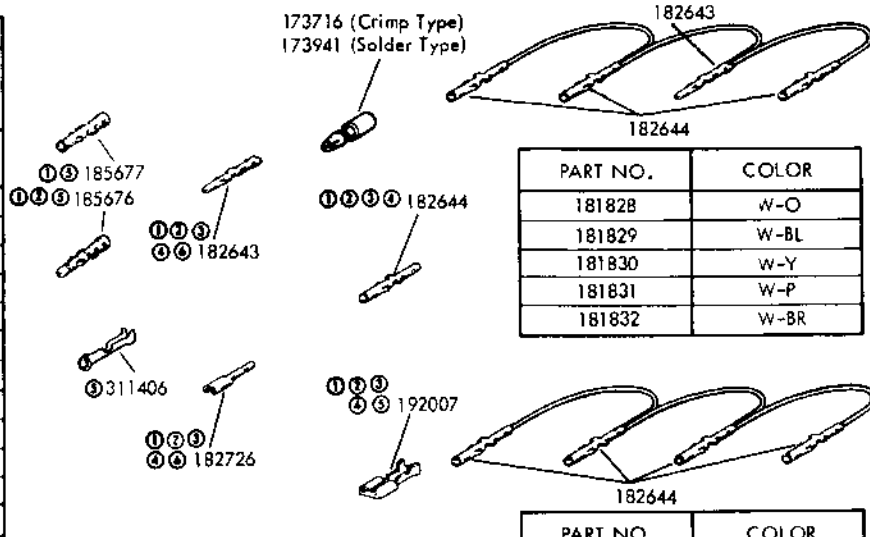

FIGURE 11. 304995 LINE RELAY MOUNTING ASSEMBLY

INSULATING SLEEVES		
PART NO.	Length	Inside Diameter
155750	1/2"	3/32"
155751	1"	1/8"
155752	1/2"	5/64"
155753	1/2"	1/8"
155754	1/2"	1/16"
155755	5/8"	11/64"
181890	1"	1/16"
181891	2 1/2"	3/16"
181892	1"	9/64"
181893	1 1/2"	3/64"
181894	2"	3/64"
181895	3/8"	9/64"

JUMPERS			
Part No.	Length	Color	Terminal
151819	3"	Black	320410
193476	2-3/4"	Black	182643

173716 (Crimp Type)  
173941 (Solder Type)



PART NO.	COLOR
181828	W-O
181829	W-BL
181830	W-Y
181831	W-P
181832	W-BR

PART NO.	COLOR
180877	W-R
180880	W-G
180884	W-S

Supplied w/ 182732 and 182733

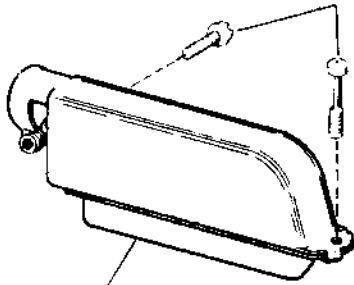

①②④ 182732 (Plug)  
①②③ 182733 (Receptacle)

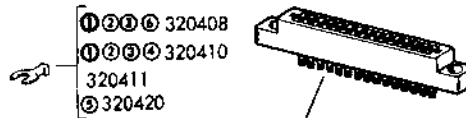

PART NO.	COLOR
182781	W-R

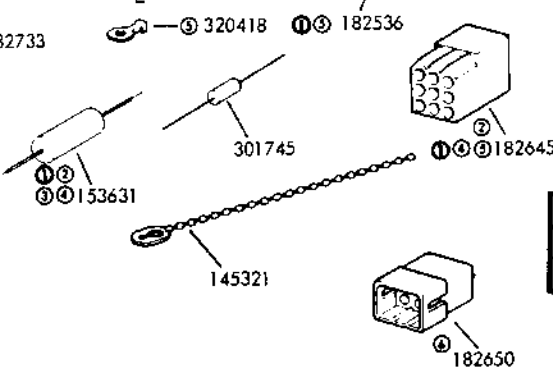

PART NO.	COLOR
182693	O
181836	BL

PART NO.	COLOR
181837	BK

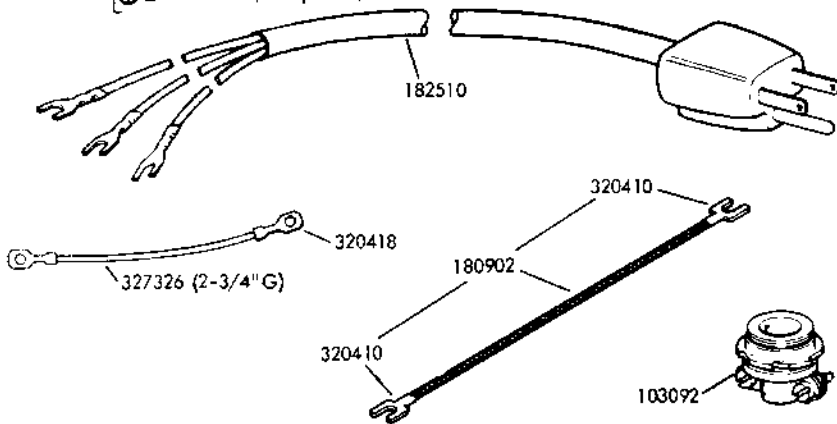

- ① 193470 Cable Assembly
- ② 193473 Cable Assembly
- ③ 301758 Cable Assembly
- ④ 305410 Cable Assembly
- ⑤ 330791 Cable Assembly
- ⑥ 305431 Cable Assembly

FIGURE 12. CABLE COMPONENTS

KEY ASSEMBLY PART LOCATION TABLE											
ASSEMBLY NO.			182580	182581	182582	182583	182584	182586	182587	182588	182589
P O S I T I O N	A	Plunger Switch	182559 182561		182559 182562	182667 182664	182667 182562	182667 182562	182667 182664	182667 182562	182559 182562
	B	Plunger Switch	182559 182560	182667 182562	182559 182562	182667 182562	182667 182562	182663 182664	182667 182562	182667 182562	182559
	C	Plunger Switch	182559 182561	182667	182559 182562	182667 182664	182559 182562	182667 182562	182667 182664	182667 182559	182559
	D	Plunger Switch	182559 182562	182667 181638	182559 182562	182667 182664	182559 182562	182667 182664	182667 182562	182667 182559	182559 182562
	E	Plunger Switch	182559 182562	182667 182562	182559 182561	182667 182562	182559 182562	182667 182664	182667 182664	182667 182559	182559 182562
	F	Plunger Switch	182559 182561		182559 182562	182663 182561	182559 182562	182663 182561	182663 182561	182663 182559	182559 182562
Plunger Spring			182554	182554	182554	182554	182554	182554	182554	182554	182554
Lockout			182556		182556					182556	182556
Latch Bar			182555		182666		308536			301769	182666
Latch Spring			182535		182535		182535			182535	182535
Bracket			182557	181637	182557	182557	182557	182557	182557	182557	182557

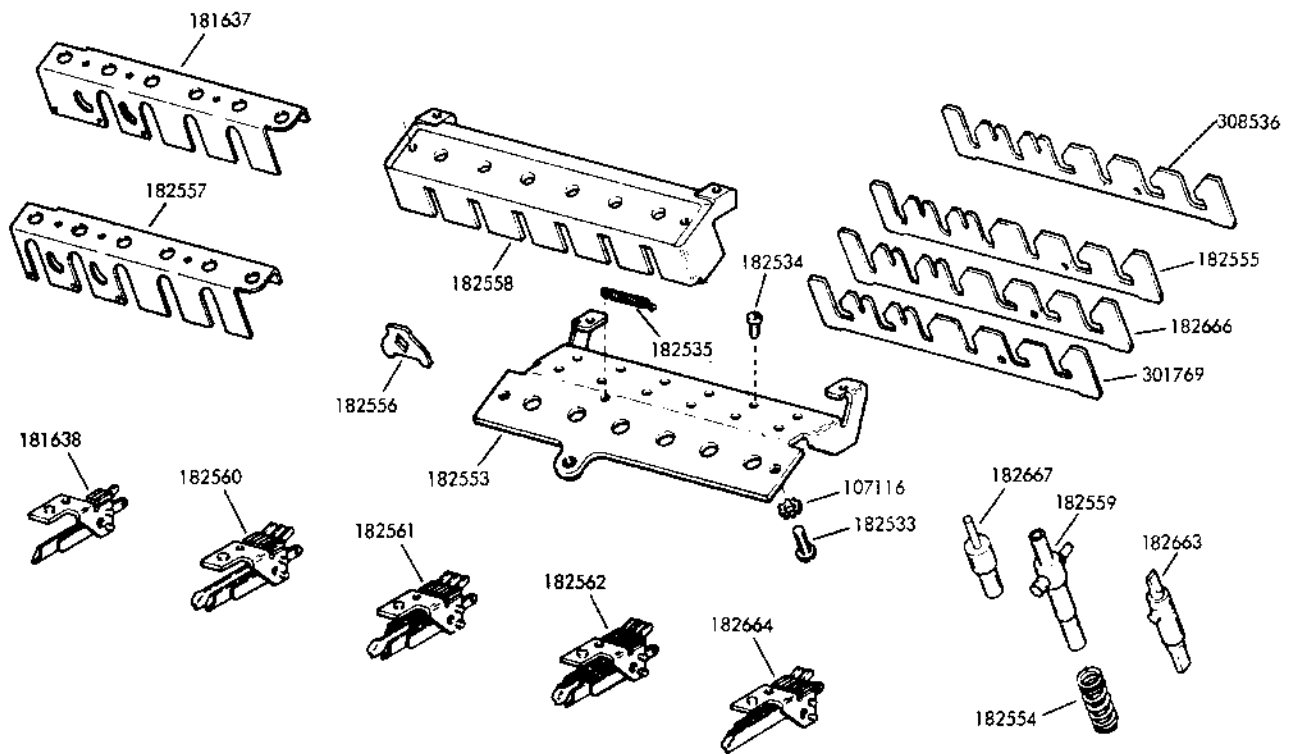

FIGURE 13. KEY ASSEMBLIES

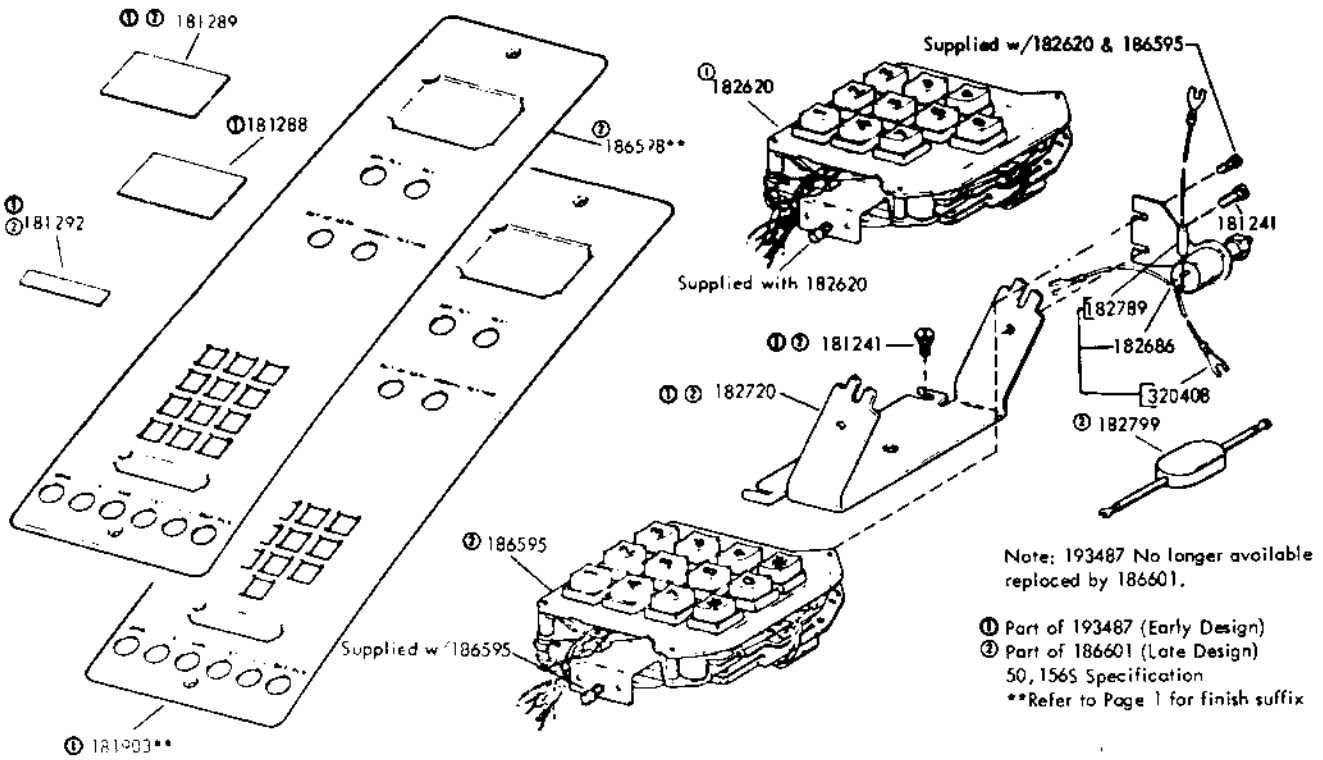
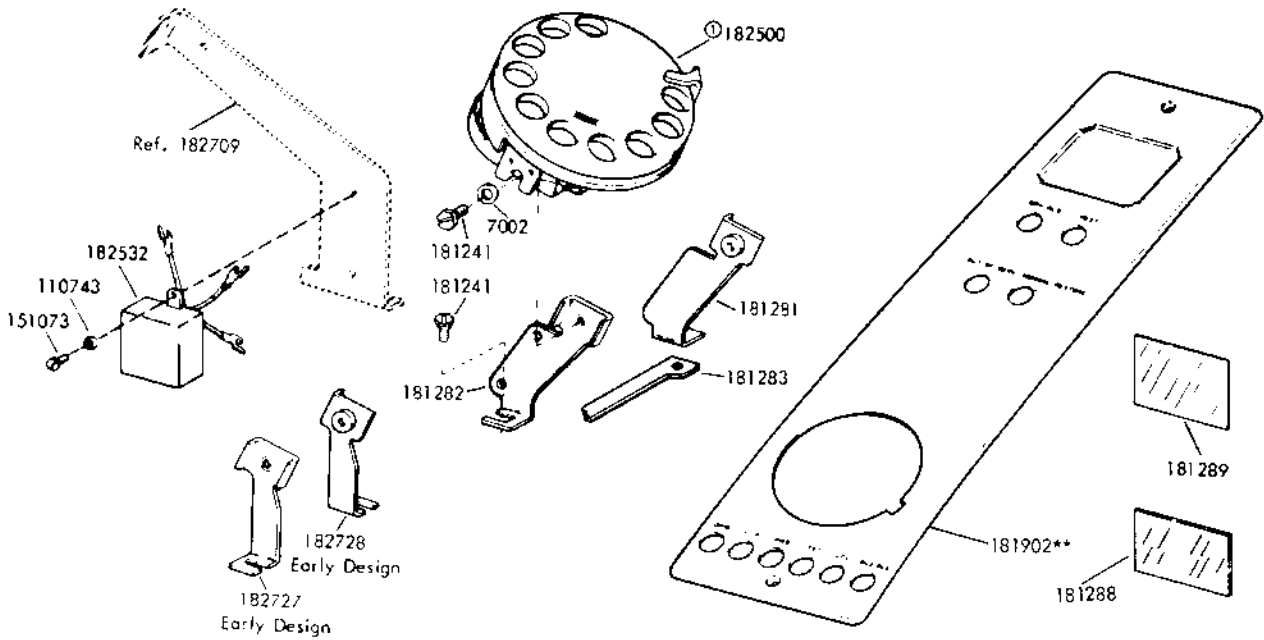

FIGURE 14. 186601 MODIFICATION KIT TO PROVIDE A TWELVE (12) BUTTON TOUCH-TONE DIALER



Note: 193489 (with Dialer) and 195926 (less Dialer) Modification Kits (Specification 501565)

\*\*Refer to Page 1 for finish suffix

① Peculiar to 193489

FIGURE 15. 193489 AND 195926 MODIFICATION KITS TO PROVIDE ROTARY DIAL

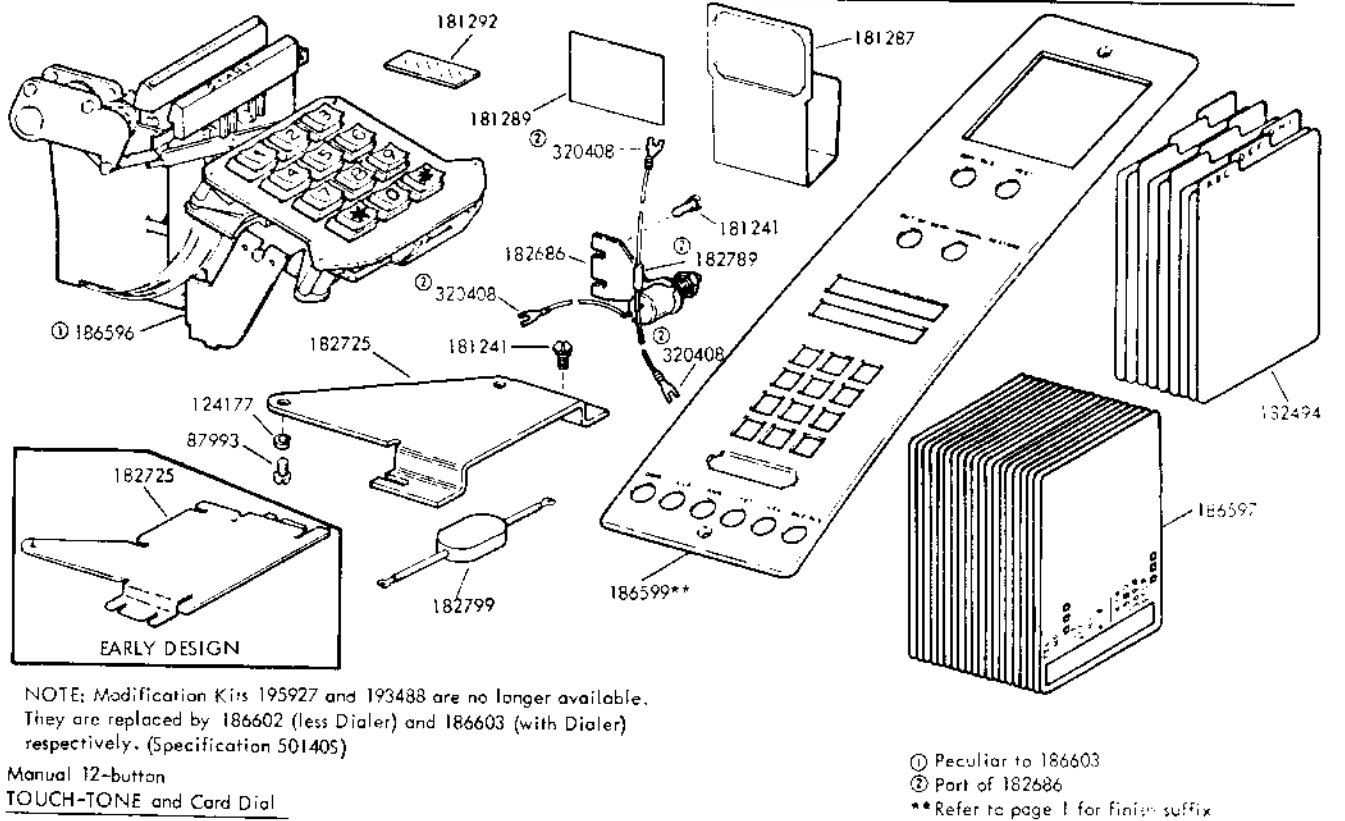
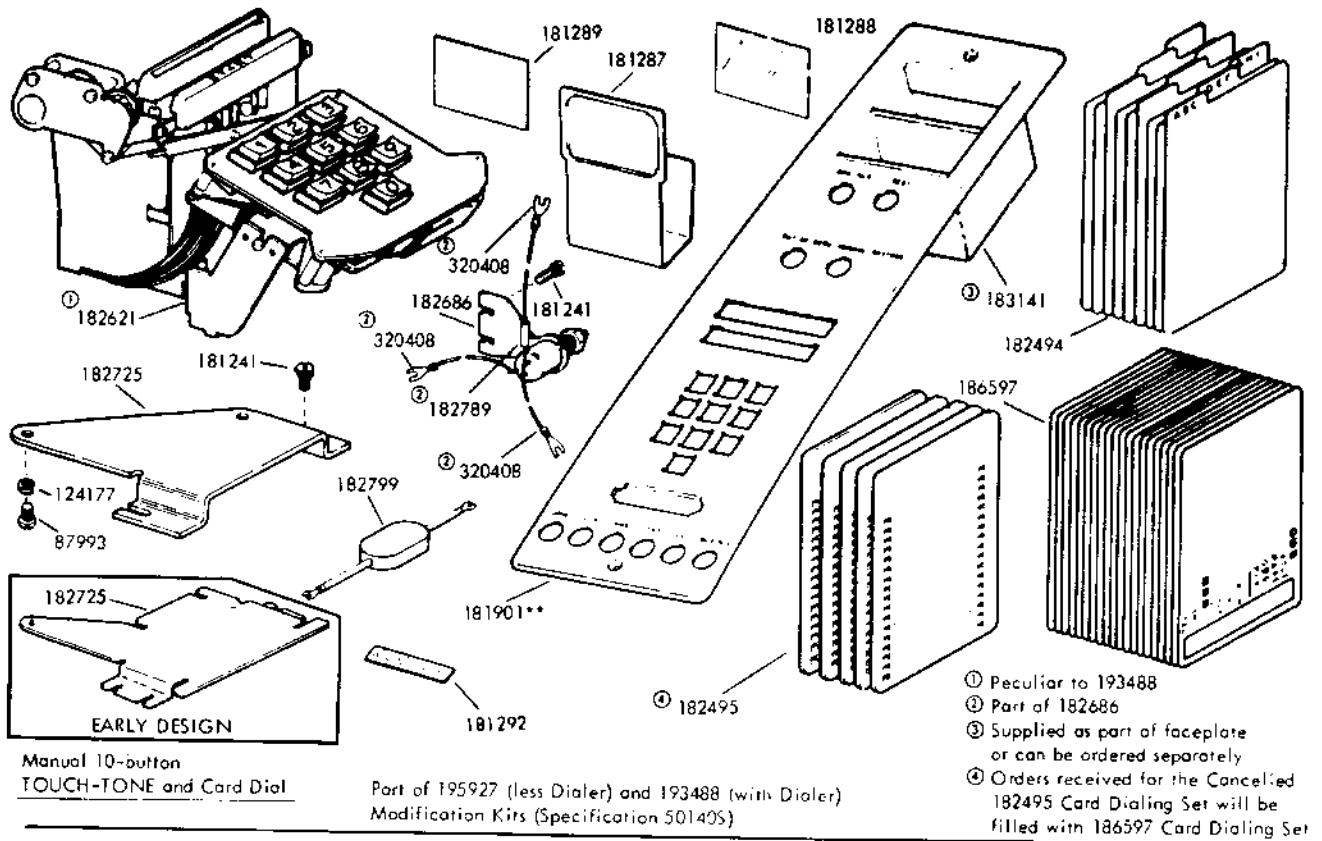
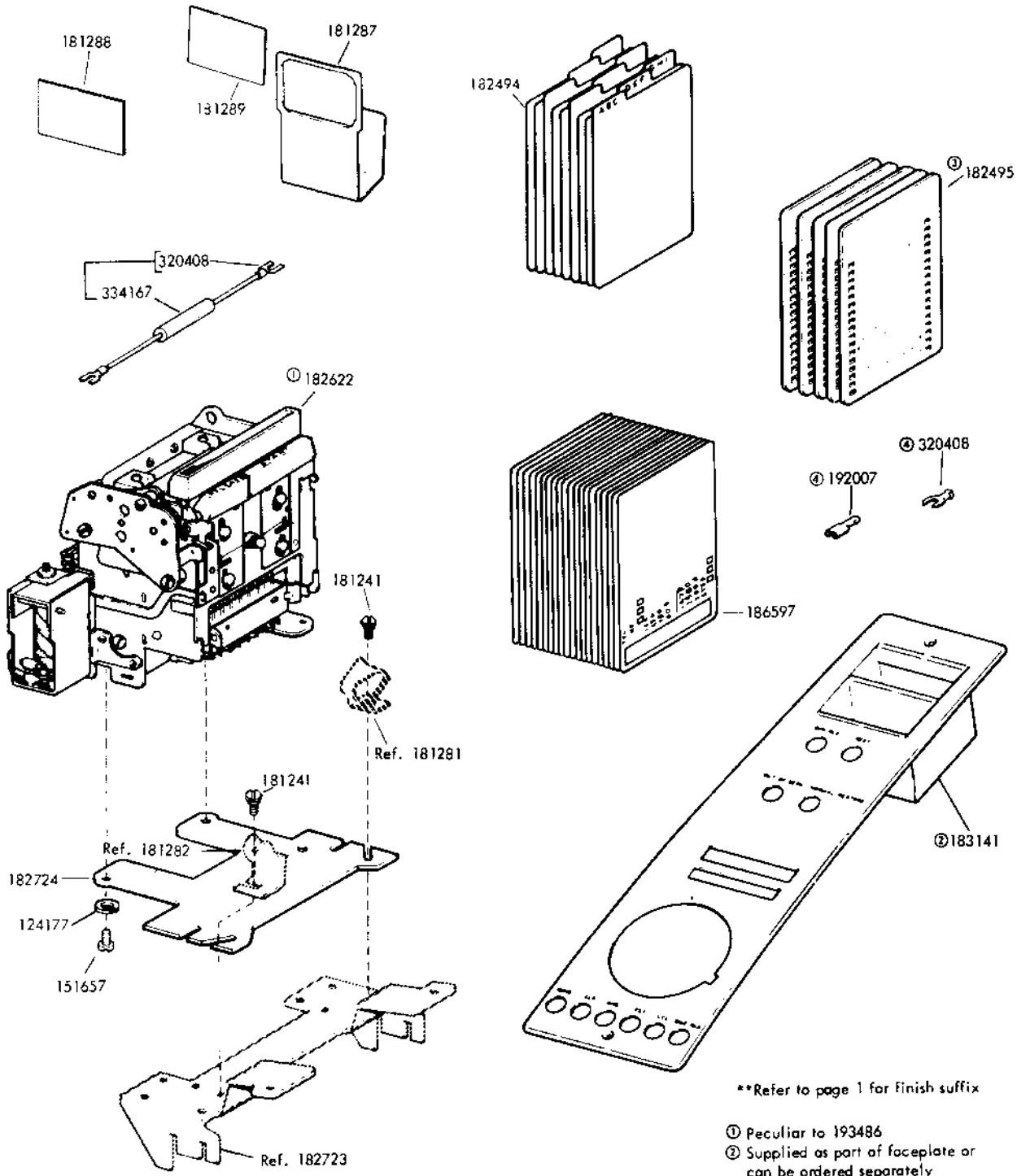

FIGURE 16. 186602, 186603, 193488 AND 195927 DIAL MODIFICATIONS



DC Cord Dial

193486 (with Dial) and 195924 (less Dial)  
(Specification 50164S)

\*\*Refer to page 1 for Finish suffix

- ① Peculiar to 193486
- ② Supplied as part of faceplate or can be ordered separately
- ③ Orders received for the cancelled 182495 Card Dialing Set will be filled with 186597 Card Dialing Set
- ④ 182698 Cable w/ Terminals

FIGURE 17. 193486 AND 195924 DIAL MODIFICATIONS



Fuse and Nameplate Chart				
Location	Fuse	Nameplate	Description	Notes
A	162360	185688	8/10 A SL-BL	Used w/ 181879 Trnsf.
B	117176	185679	1.2A SL-BL	Used w/ 181879 Trnsf.
C		185678	3/8 A SL-BL	

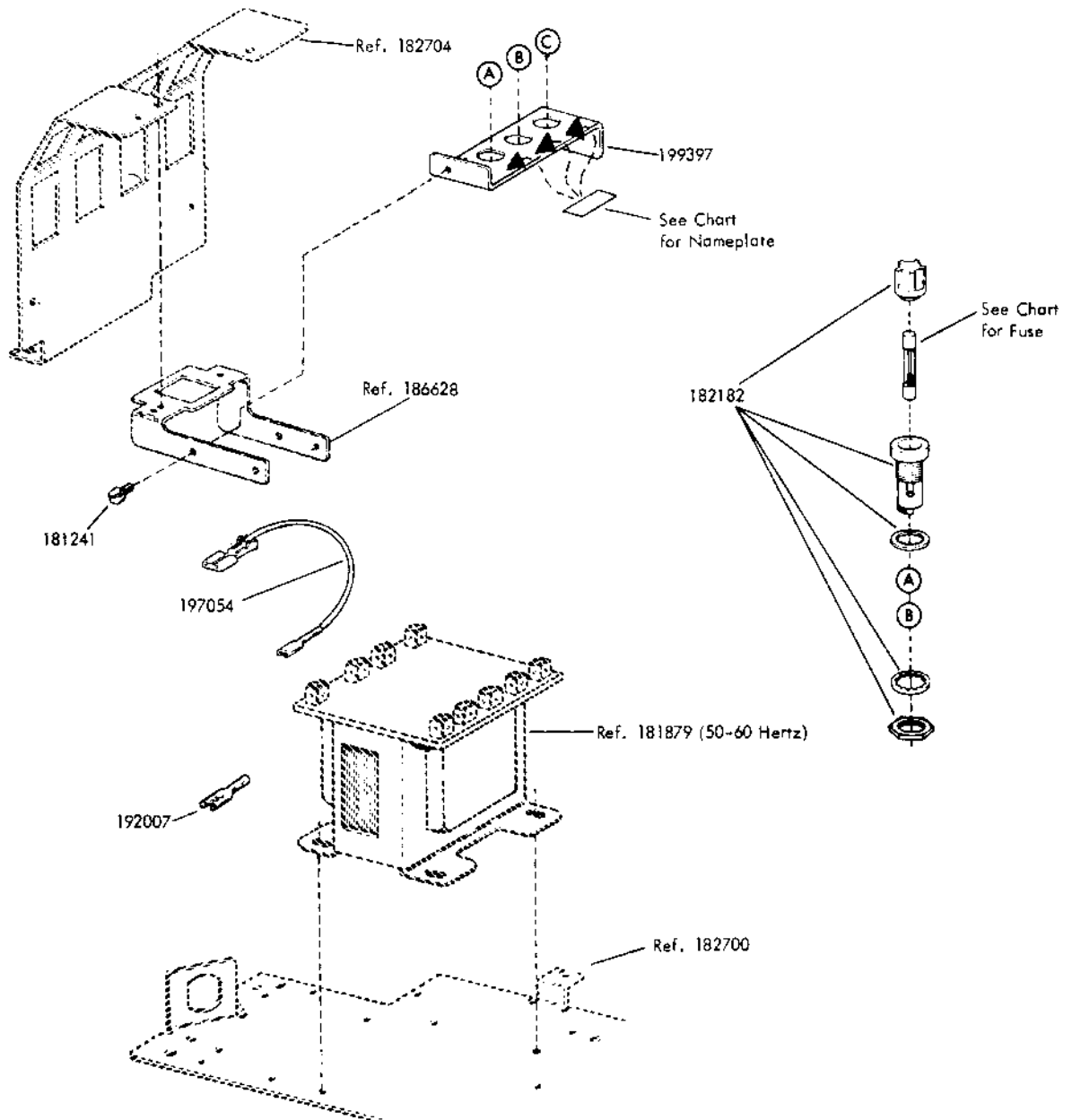

Specification 504235

FIGURE 18. 199409 MODIFICATION KIT TO PROVIDE FUSING IN THE PRIMARY OF THE CALL CONTROL LOW VOLTAGE TRANSFORMER

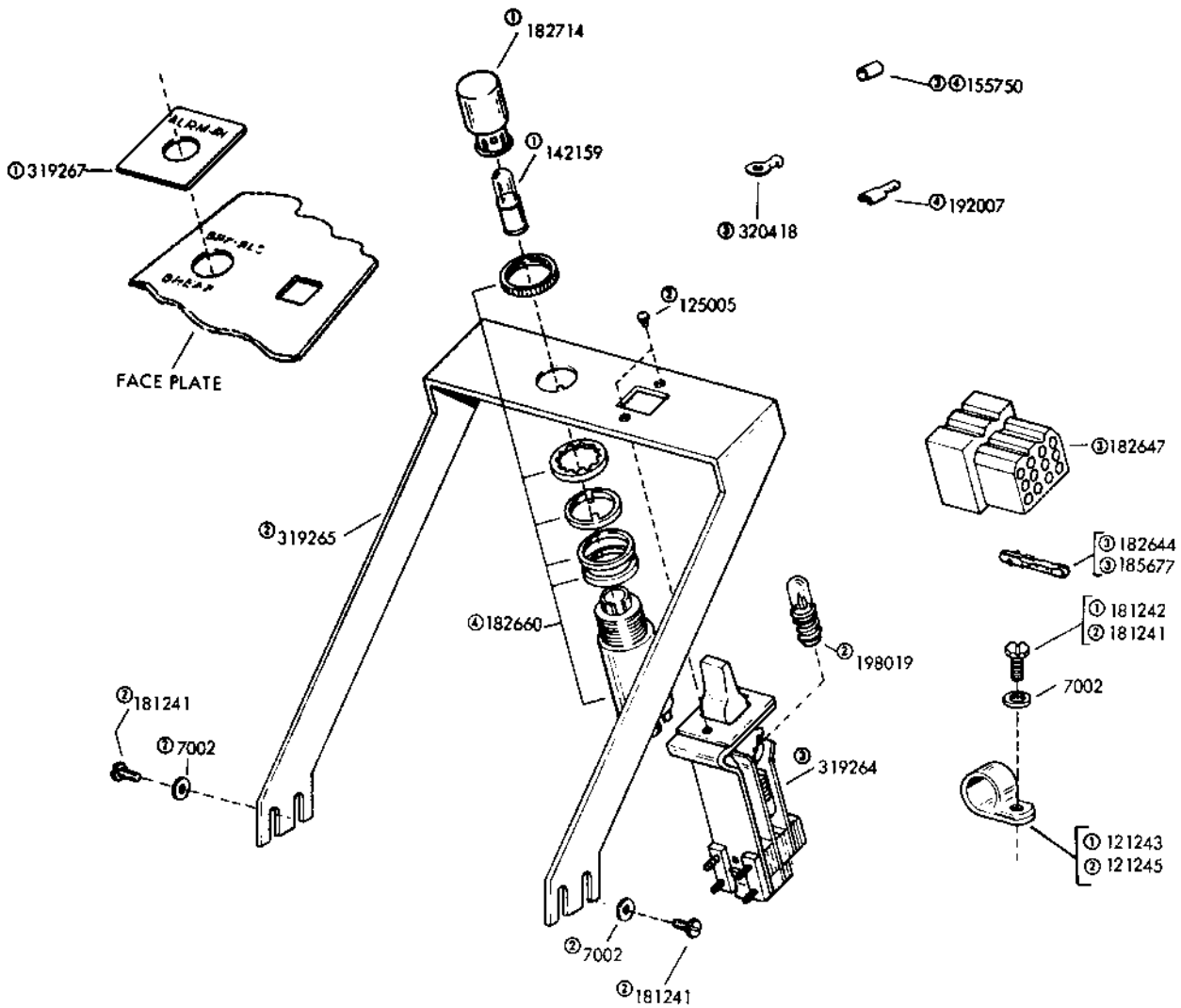

Specification 50,4665

- ① Peculiar to 319274
- ② Peculiar to 320489
- ③ 319263 Cable Assembly, Peculiar to 320489
- ④ 319269 Cable Assembly, Peculiar to 319274

FIGURE 19. 319274 AND 320489 MODIFICATION KITS TO ADD ALARM LAMPS WITH RELEASE SWITCHES

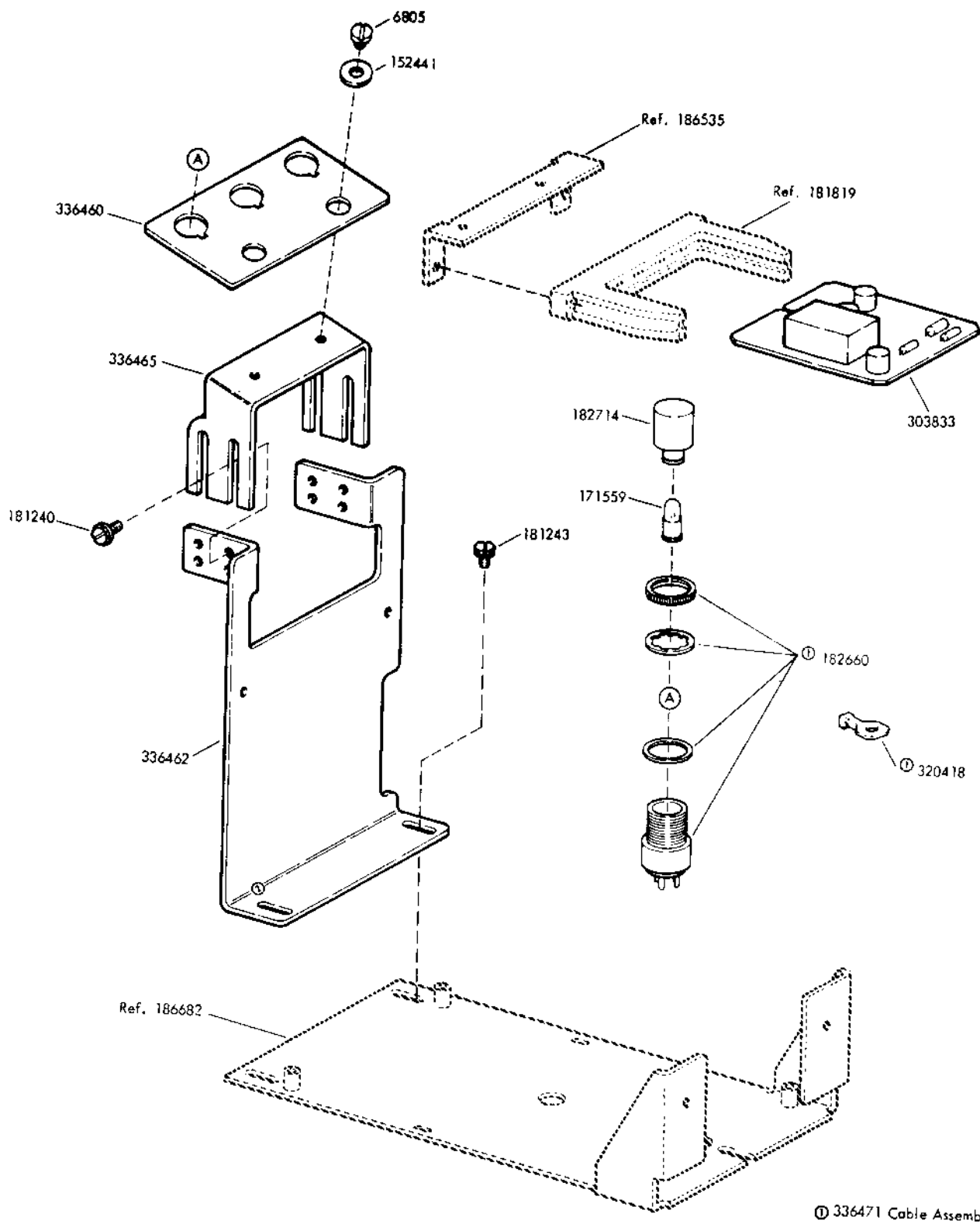

FIGURE 20. SIGNAL LINE BREAK DETECTION AND INDICATION FEATURES

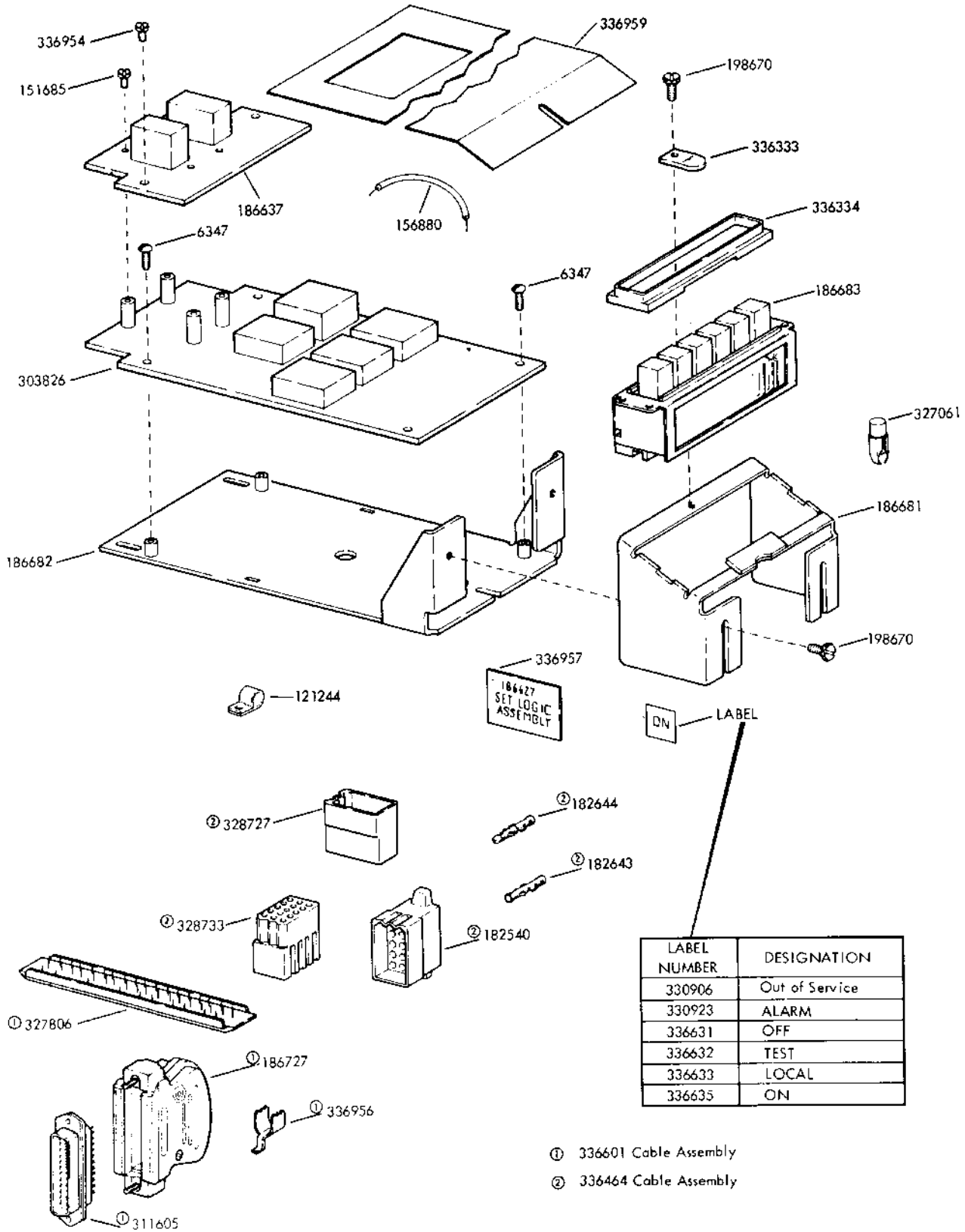

FIGURE 21. 186627 SET INTERFACE LOGIC ASSEMBLY

## NUMERICAL INDEX

Part Number	Description and Page Number	Part Number	Description and Page Number	Part Number	Description and Page Number
1010	Screw, 6-40 Shoulder 2	117176	Fuse, SL-BL 0.5 Amp 4, 9,17	153631	Network, Spark Suppression 6,8,12
1018	Screw, 3-48 x 5/16 Fil 5	121243	Clamp, 3/16 ID Cable 18	153799	Screw, 4-40 x 21/64 Hex 3
1028	Screw, 4-40 x 1/4 Fil 3, 11	121244	Clamp, 1/4 ID Cable 20	153817	Screw, 4-40 x 3/8 Hex 3
1248	Screw, 6-40 x 1/2 Flat 11	121245	Clamp, 5/16 ID Cable 18	155750	Sleeve, 3/32 ID x 1/2" Lg Insulating 6,10,12,18
2191	Lockwasher 5,6,9 to 11	124177	Lockwasher 4,5,7,10,15,16	155751	Sleeve, 1/8 ID x 1" Lg Insulating 12
3598	Nut, 6-40 Hex 5,6,9 to 11	125005	Screw, 2-56 x 3/16 RD 18	155752	Sleeve, 5/64 ID x 1/2" Lg Insulating 12
3606	Nut, 6-40 Hex 5	125011	Washer, Flat 3,10	155753	Sleeve, 1/8 ID x 1/2" Lg Insulating 6,10,12
3640	Lockwasher 9	125015	Washer, Flat 3,4,5,10,11	155754	Sleeve, 1/16 ID x 1/2" Lg Insulating 12
3649	Washer, Flat 4,5	125205	Screw, 6-40 x 7/16 Fil 10	155755	Sleeve, 11/64 ID x 5/8" Lg Insulating 4,6,10,12
6347	Screw, 6-32 x 3/8 RD 20	128608	Rheostat, 3,500 Ohm 11	156450	Screw, 2-56 x 1/2 Fil 10
6805	Screw, 6-40 Shoulder 9, 19	129919	Fuse, SL-BL 4 Amp 4,9	156630	Washer, Felt 3
6827	Block 11	142159	Bulb, 6V Lamp 18	156880	Jumper, 2-3/8" Black 20
7001	Washer, Flat 10	143613	Lamp, 14V Incandescent 9	159597	Washer, Flat 3
7002	Washer, Flat 2 to 6, 8 to 11,14,18	144590	Screw, 6-40 x 1-3/8 Fil 5,10	159931	Clamp 4
8330	Washer, Flat 4,10	145321	Tie, Cable 12	159932	Keeper 4
70072	Lockwasher 5	147209	Switch, SP-ST Pushbutton 9	160859	Terminal 5
71073	Washer, Flat 10	150705	Bushing 11	161136	Fuse, SL-BL 6-1/4 Amp 4
74615	Resistor, 2,000 Ohm 11	150710	Screw, 6-40 x 1-1/4 Fil 10	162360	Fuse, SL-BL .8 Amp 4,17
75750	Washer, Insulating 11	150966	Insulator, Terminal Block 2	162441	Resistor, 3,750 Ohm 11
77902	Screw, 6-40 x 2-3/8 RD 11	150978	Screw, 6-40 x 1-1/8 Fil 5	171536	Resistor, 2,250 Ohm 6
77920	Screw, 6-40 x 1-15/16 Fil 11	150982	Screw, 4-40 x 7/16 Fil 3	171559	Lamp, 28V Incandescent 19
81775	Resistor, 8,000 Ohm 11	151073	Screw, 4-40 x 5/32 Fil 2, 14	173716	Terminal, Receptacle Type 12
82516	Spring, Retaining 11	151335	Stud 2,4,6,11	173941	Terminal, Receptacle Type 12
87993	Screw, 6-40 x 5/32 Fil 7,15	151411	Block, Terminal 4,6	177113	Insulator 5,10
90096	Washer, Insulating 9	151412	Insulator, Terminal Block 4,6	178535	Suppression, Spark 2
90787	Screw, 4-40 x 3/8 Hex 3	151415	Block, Terminal 2	178831	Connector, 2 Pt Receptacle 4,9
91943	Jumper, 2-1/4" Black 6	151416	Nut, 6-40 Hex 2,4,6	178832	Plate, Adapter 4,9
92260	Lockwasher 3	151442	Screw, 6-40 x 1/2 Hex 5, 10	178883	Resistor, 1,500 Ohm 6
93117	Lockwasher 10	151631	Screw, 6-40 x 5/16 Hex 11	179486	Cover, Insulator 11
96717	Screw, 4-40 Shoulder 3	151657	Screw, 6-40 x 1/4 Fil 16	180586	Sleeve, 5/32 ID x 21/32" Lg Insulating 12
98726	Screw, 3-48 x 1/4 Fil 5	151660	Screw, 6-40 x 7/8 Fil 4	180877	Jumper, 2-3/4" White-Red 12
98738	Resistor, 1,000 Ohm 11	151685	Screw, 4-40 x 5/16 Fil 20	180880	Jumper, 2-3/4" White-Green 12
99744	Resistor, 8,000 Ohm 11	151693	Screw, 6-40 x 9/16 Fil 5	180884	Jumper, 2-3/4" White-Slate 12
103092	Connector, Card 12	151734	Screw, 4-40 x 3/8 Hex 9	180902	Jumper, 3-1/2" Braided 12
107116	Lockwasher 5,10,13	151819	Jumper, 3" Black 12	180904	Tab, Terminal 4,6
110435	Nut, 4-40 Hex 10	151827	Strap, Terminal 6		
110743	Lockwasher 2,3,10,14	152124	Spacer 11		
111017	Screw, 6-40 x 5/16 Fil 2, 4,6	152441	Washer, Flat 9,19		
112485	Screw, 6-32 x 1/4 Fil 9	152634	Washer, Flat 2		
112620	Screw, 4-40 x 1/2 Hex 3, 10	152893	Screw, 4-40 x 1/4 Hex 2,3		
113442BR	Jumper, 2-1/2" Brown 6	153464	Block, Terminal 11		
114626	Screw, 6-40 x 2-1/16 Fil 9	153484	Screw, 6-32 Spl 2		

## NUMERICAL INDEX (Continued)

Part Number	Description and Page Number	Part Number	Description and Page Number	Part Number	Description and Page Number
181240	Screw w/Lockwasher, 6-40 x 3/16 Hex 4,7 to 10,19	181891	Sleeve, 3/16 ID x 2-1/2" Lg Insulating 12	182554	Spring, Compression 13
181241	Screw w/Lockwasher, 6-40 x 1/4 Hex 2 to 11,14 to 18	181892	Sleeve, 9/64 ID x 1" Lg Insulating 12	182555	Bar, Latch 13
181242	Screw w/Lockwasher, 6-40 x 5/16 Hex 4,18	181893	Sleeve, 3/64 ID x 1-1/2" Lg Insulating 6,12	182556	Lockout 13
181243	Screw w/Lockwasher, 6-40 x 3/8 Hex 4,19	181894	Sleeve, 3/64 ID x 2" Lg Insulating 12	182557	Bracket 13
181246	Screw w/Lockwasher, 6-40 x 5/8 Hex 10	181895	Sleeve, 9/64 ID x 3/8" Lg Insulating 12	182558	Frame 13
181266	Bushing, Insulating 10	181901**	Faceplate 15	182559	Plunger 13
181281	Bracket, Right 8,14,16	181902**	Faceplate 14	182560	thru
181282	Bracket, Left 8,14,16	181903**	Faceplate 14	182562	Contact Assembly 13
181283	Spacer, .065" Thk 2,14	181999	Insulator 10	182563	Plate w/Bracket 3
181287	Holder, Card 15,16	182090	Dial Assembly, Touch Tone & Card 1,7	182565	Bracket 3
181288	Label, White 14 to 16	182091	Dial Assembly, Rotary 1,8	182566	Bracket, Left 3
181289	Window, Plastic 14 to 16	182092	Dial Assembly, Manual Touch Tone 1,7	182569	Clamp 6
181292	Window, Plastic 14,15	182093	Dial Assembly, DC Card 1,8	182571	Screw, 6-40 Shoulder 3
181392	Terminal, Tab Type 4	182162	Post 5	182576	Bracket, Right 3
181424	Nut, 6-40 Sq 10	182181	Fan 4	182577	Bracket 3
181631	Strip Assembly, Lamp 3	182182	Holder, Fuse 4,9,17	182580	thru
181632	Button Assembly 3	182251	Plate, Identification 5	182584	Key Assembly 13
181637	Bracket 13	182284	Insulator, .015" Thk 10	182586	thru
181638	Contact Assembly 13	182494	Card Set, Index 7,15,16	182589	Key Assembly 13
181645	Dial, Rotary 3	182495	Card Set, Dialing 7,15,16	182611	Fuse, SL-BL 3/8 Amp 6
181661	Buzzer, 115V AC 3	182500	Dial, Rotary 3,8,14	182615	Pad 6
181672	Relay, Power 5	182501	Capacitor, 1,500 MFD 5,10	182619	Screw, 6-40 Shoulder 2
181675	Transistor, Power 5,10	182502	Nut, No.14 Speed 2,3	182620	Dial, Touch Tone 7,14
181818	Cable Assembly 10	182503	Ringer w/Terminals 2	182621	Dial, Touch Tone & Card 7,15
181819	Connector, 15 Pt Circuit Card 10,19	182510	Card, Power 12	182622	Dial, DC Card 8,16
181822	Bracket 10	182523	Clamp, 1-3/8" ID Mounting 10	182630	Card, Circuit 10
181826	Jumper, 2" Black 4	182524	Button Assembly 3	182643	Terminal, Plug Type 4,10 to 12,20
181828	Jumper, 2-3/4" White-Orange 12	182527	Screw, 4-40 Shoulder 3	182644	Terminal, Receptacle Type 12,18,20
181829	Jumper, 2-3/4" White-Blue 12	182529	Lamp, 10V 3	182645	Connector, 9 Pt Receptacle Type 12
181830	Jumper, 2-3/4" White-Yellow 12	182532	Filter 2,14	182647	Connector, 12 Pt Plug Type 18
181831	Jumper, 2-3/4" White-Purple 12	182533	Screw, 6-32 x 5/16 RD 13	182650	Connector, 6 Pt Plug Type 12
181832	Jumper, 2-3/4" White-Brown 12	182534	Screw, 4-40 Spl 13	182658	Socket, Lamp 9
181836	Jumper, 4-1/2" Black 12	182535	Spring 13	182660	Switch, Pushbutton 9,18,19
181837	Jumper, 4-1/2" Black 12	182536	Connector, 15 Pt Circuit Card 4,5,10,12	182661	Holder, Fuse 6
181848	Nameplate 4	182539	Connector, 15 Pt Receptacle Type 4,6	182663	Plunger 13
181879	Transformer, Power 4,17	182540	Connector, 15 Pt Plug Type 4,20	182664	Contact Assembly 13
181890	Sleeve, 1/16 ID x 1" Lg Insulating 12	182553	Baseplate 13	182666	Bar, Latch 13

\*\*Refer to page 1 for finish suffix

## NUMERICAL INDEX (Continued)

Part Number	Description and Page Number	Part Number	Description and Page Number	Part Number	Description and Page Number
182684	Strap 3	182795	Switch, DP-DT 9	193476	Jumper, 2-3/4" Black 4,12
182686	Resistor Assembly, 50,000 Ohm 7,14,15	182796	Insulator, .032" Thk 4	193486	Modification Kit 1,16
182688	Switch, Turn Button 9	182799	Capacitor, .20 -.30 MFD 4,7,14,15	193487	Modification Kit 14
182693	Jumper, 2-1/4" Orange 12	183111	Label 10	193488	Modification Kit 1,15
182695	Driver Assembly, Selector Magnet 1,10	183141	Holder, Card 15,16	193489	Modification Kit 1,14
182696	Cable Assembly 10	183524	Button, Turn 9	195566	Cap, Blue Lens 9
182698	Cable w/Terminals 8,16	183525	Washer, Flat 9	195614	Pin, Key 4,6
182700	Baseplate 2,4,10,17	183526	Ring, Retaining 9	195618	Jumper, 5-1/4" White-Purple 6
182704	Bracket 4,17	185676	Terminal, Plug Type 10, 12	195924	Modification Kit 1,16
182706	Plate, Pilot 9	185677	Terminal, Receptacle Type 5,12,18	195926	Modification Kit 1,14
182707	Bracket, Pilot 9	185678	Plate, Identification 6,17	195927	Modification Kit 1,15
182708	Bracket, Left 2	185679	Plate, Identification 4,9, 17	197054	Jumper, 3" Black 17
182709	Bracket, Right 2,14	185684	Plate, Identification 4,9	198019	Lamp, 6V 18
182710	Bracket, Upper 4	185686	Plate, Identification 4	198515	Card, Circuit 5
182711	Bracket, Lower 4	185688	Plate, Identification 4, 17	198517	Bracket 5
182713	Cap, Amber Lens 9	186059	Terminal 5,10	198518	Bushing, Insulating 5,10
182714	Cap, White Lens 9,18,19	186060	Screw, 6-40 Shoulder 3	198519	Insulator 5
182715	Cap, Red Lens 9	186224	Plate 3	198520	Insulator, .062" Thk 5
182716	Connector, 9 Pt Plug Type 10	186535	Bracket 19	198521	Bracket 5
182717	Board, Terminal 3	186595	Dial, Touch-Tone 7,14	198522	Clip, Spring 5
182718	Buzzer, 10V AC 2	186596	Dial, Touch-Tone 7,15	198528	Bracket 6
182719	Bracket, Guide 4	186597	Card Set Dialing 7,15,16	198529	Strip, Terminal 6
182720	Bracket, Dial 7,14	186598**	Faceplate 14	198650	Key, Polarizing 10
182721	Bracket 2	186599**	Faceplate 15	198670	Screw w/Lockwasher, 6-40 x 5/16 Hex 20
182722	Transformer w/Terminals 10	186601	Modification Kit 1,14	199311	Insulator 9
182723	Bracket 2,3,8,16	186602	Modification Kit 1,15	199397	Bracket, Fuse 4,17
182724	Plate, Dial 8,16	186603	Modification Kit 1,15	199409	Modification Kit 1,17
182725	Plate, Tone Dialer 7,15	186627	Logic Assembly 1,20	300340	Bushing 2
182726	Terminal, Receptacle Type 10,12	186628	Bracket 4,17	301706	Plate, Mounting 2
182727	Bracket, Left 8,14	186637	Card, Circuit 20	301712	Ringer 2
182728	Bracket, Right 8,14	186681	Bracket 20	301713	Connector, 2 Pt Receptacle 4
182729	Link, Ringer 2	186682	Bracket 19,20	301716	Resistor, 5,000 Ohm 2
182731	Post 4	186683	Key Assembly 20	301721	Resistor, 5,000 Ohm 7
182732	Connector, 50 Pt Plug 12	186727	Clamp 20	301743	Dial, Touch-Tone 7
182733	Connector, 50 Pt Receptacle 12	186739	Cover 10	301745	Diode 12
182750	Card, Amplifier Circuit 4	186741	Jumper, 9" Green 4	301756	Plate, Pilot 9
182761	Capacitor, 0.5 MFD 2	187069	Barrier 5	301757	Switch, Illuminated Pushbutton 9
182765	Plate, Volume Control 7	192007	Terminal, Tab Type 8, 12, 16 to 18	301758	Cable Assembly 12
182768	Bracket, Fuse 4	192285	Bracket, Receptacle 4	301759	Capacitor, .40-.60 MFD 4
182769	Block 9	193434	Button Assembly 3	301766	Resistor, 270 Ohm 4
182781	Jumper, 2-3/4" White-Red 12	193438	Strip, Lamp 3	301769	Bar, Latch 13
182789	Resistor, 200 Ohm 7,14,15	193470	Cable Assembly 12	301778	Resistor, 75 Ohm 9
182791	Bracket 9	193472	Plug w/Straps 4	303163	Card, Circuit 5
182793	Plate, Heat Sink 10	193473	Cable Assembly 12	303810	Card, Circuit 6
				303826	Card, Circuit 20

\*\*Refer to page 1 for finish suffix

## NUMERICAL INDEX (Continued)

Part Number	Description and Page Number	Part Number	Description and Page Number	Part Number	Description and Page Number
303833	Card, Circuit 19	319274	Modification Kit 1,18	330906	Label, Out of Service 20
304992	Bushing, Block 3	320408	Terminal, Spade Type 7, 8,12,14,15,16	330923	Label, Alarm 20
304995	Mounting Assembly, Line Relay 1,11	320410	Terminal, Spade Type 12	333515	Shield, Transformer 10
304996	Cable 11	320411	Terminal, Spade Type 12	334167	Network, Spark Suppression 8,16
304997	Relay, Line Mercury 11	320412	Terminal, Spade Type 5,10	334847	Lamp, 14V 9
304998	Plate, Relay Mounting 11	320418	Terminal, Ring Type 4, 12,18,19	336333	Plate, Nut 20
304999	Bracket 11	320420	Terminal, Ring Type 10, 12	336334	Collar 20
305084	Bracket 11	320489	Modification Kit 1,18	336460	Plate 19
305407	Plate, Pilot 9	321543	Bracket 10	336462	Bracket 19
305409	Cap, Blue Lens 9	327061	Lamp, 24 V 20	336464	Cable Assembly 20
305410	Cable Assembly 12	327326	Jumper, 2-3/4" Green 12	336465	Bracket 19
305431	Cable Assembly 12	327806	Plug 20	336471	Cable Assembly 19
305453	Transformer w/terminals 5	328591	Strap, Cable 4	336601	Cable Assembly 20
305454	Transformer 5	328727	Connector, 15 Pt Plug Type 20	336631	Label 20
305688	Card, Circuit 6	328733	Connector, 15 Pt Receptacle Type 20	336632	Label 20
305689	Card, Circuit 6	330781	Shield, Transformer 5	336633	Label 20
308536	Bar, Latch 13	330782	Shield, Transformer 5, 10	336635	Label 20
311406	Terminal, Receptacle Type 10,12	330791	Cable Assembly 12	336954	Screw, 4-40 x 13/64 Fil 20
311605	Connector, 25 Pt Plug 20	330792	Transformer 10	336956	Stayband 20
319263	Cable Assembly 18			336957	Label 20
319264	Switch 18			336959	Cover 20
319265	Bracket 18			337995	Transformer 5
319267	Plate, Identification 18			343470	Label 4
319269	Cable Assembly 18				



35 CONSOLE AND TABLE MODEL CABINET (LAC) KSR/RO

PARTS

FIGURE	CONTENTS	PAGE	FIGURE	CONTENTS	PAGE
1	Upper and Lower Covers	2	14	Lamp Brackets and Line Guides	13
2	Pedestal	3	15	Paper Handling and Directory Holder	
3	Mounting Frame	4		Modification Kits	14
4	Pans - Table Model	4	16	Hand Held Receiver, Speaker and Signal Bell	15
5	Pedestal and Lower Cover	5	17	307228** Modification Kit to add Offset Copyholder	16
6	Pedestal	6	18	333456 Modification Kit to Provide Mobility for Cabinet	17
7	Upper and Lower Cover	7	19	336932 Modification Kit to Provide Audible and Visible Alarm on low Paper Numerical Index	18
8	Faceplates	8			19
9	Control Panels	9			
10	Control Panels	10			
11	Control Panel Components	11			
12	Control Panel Components (Continued)	12			
13	178387 Modification Kit to Provide High Voltage Static Eliminator to Neutralize Electrostatic Charge on Page Copy	12			

PAINT FINISH COLOR CODE CHART			
COLOR	Finish Suffix		
	Smooth Finish	Textured Vinyl	Smooth Vinyl
Charcoal Gray	BZ		HA
Dark Covert Gray	FC		
Light Gray			HB
Light Olive Gray	EW		HF
Gray Green	BK	GA	

The double asterisk(\*\*) denotes a painted part.  
 Suffix to be applied following the part number.

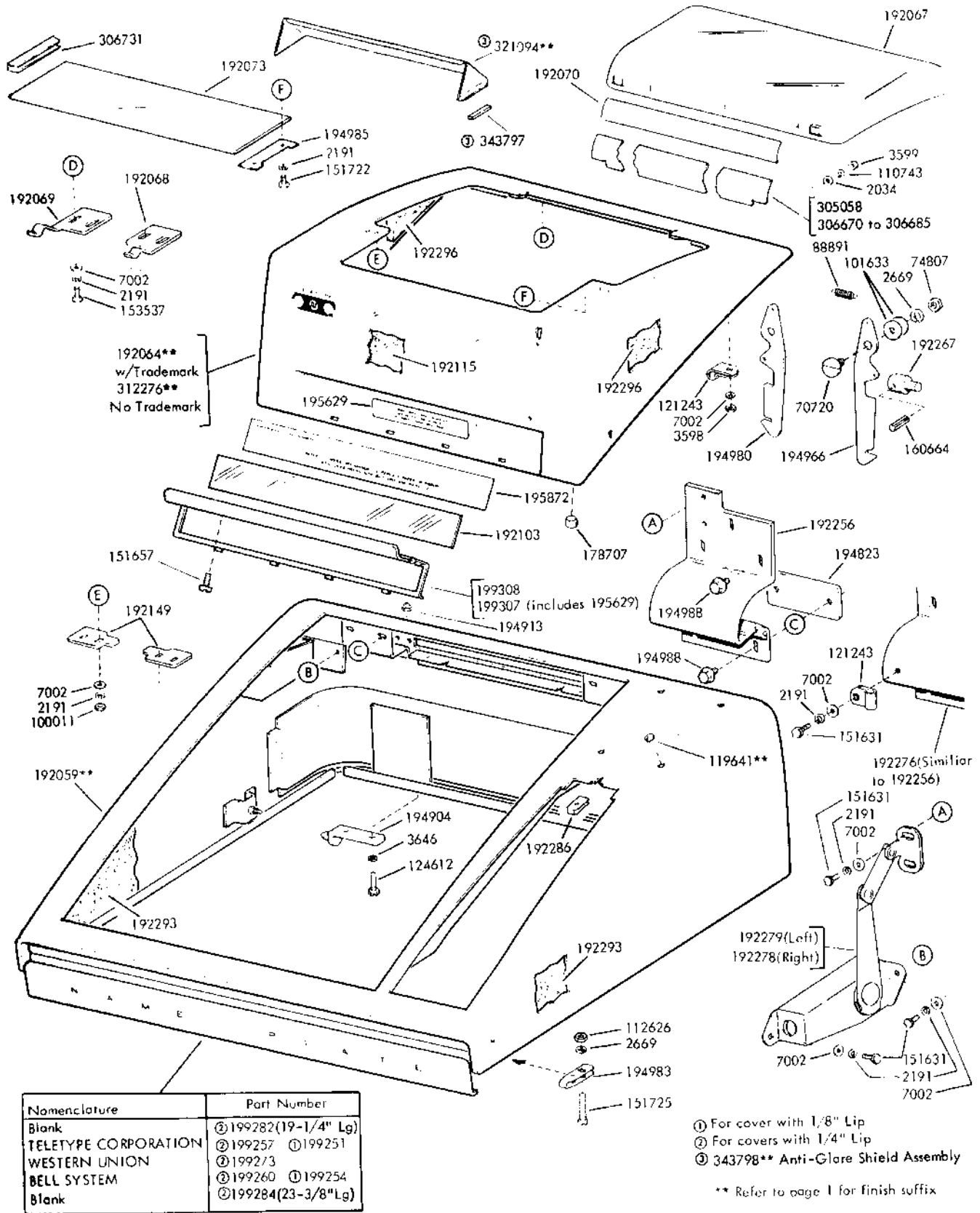
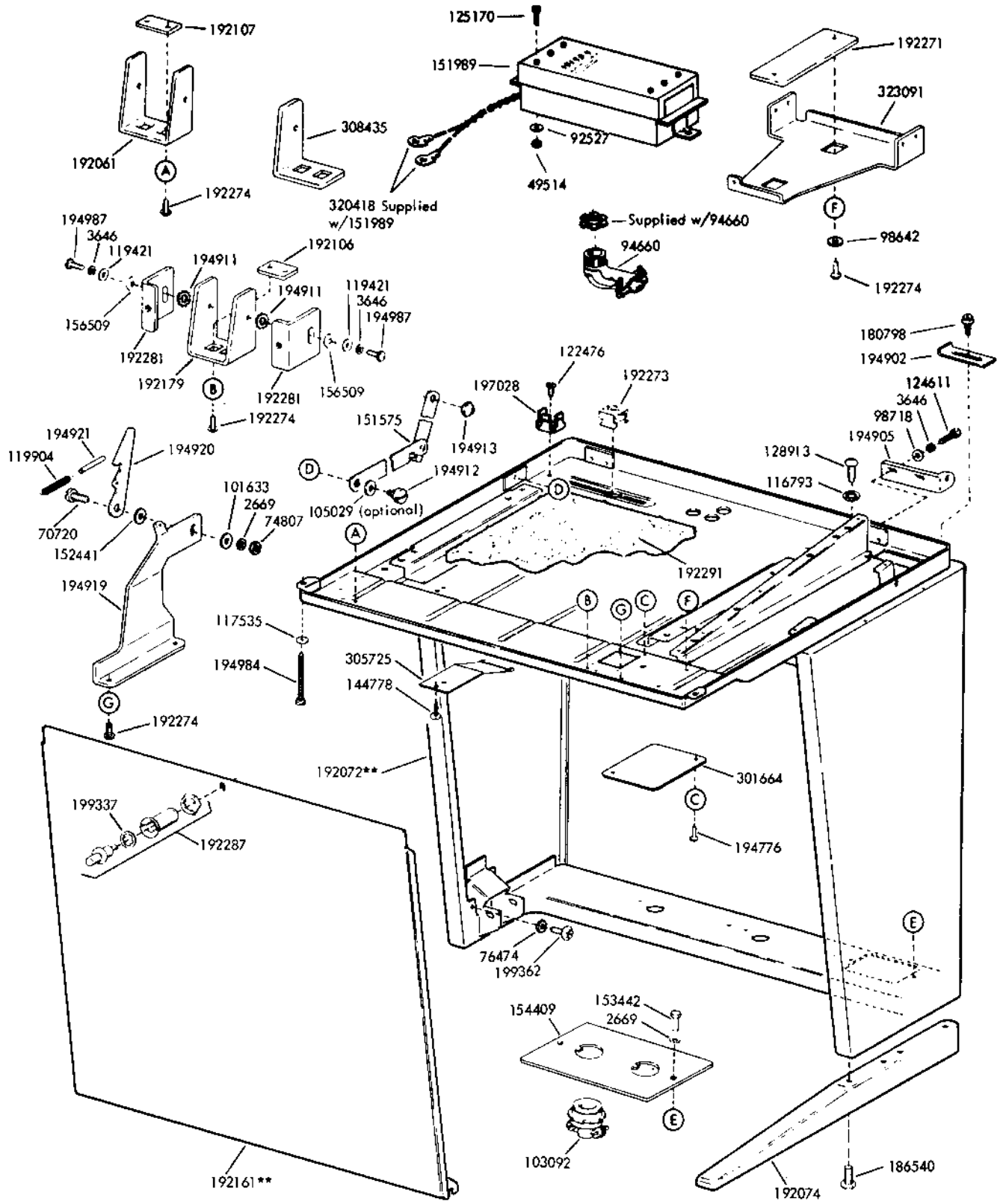

FIGURE 1. UPPER AND LOWER COVERS



\*\* Refer to page 1 for finish suffix

FIGURE 2. PEDESTAL

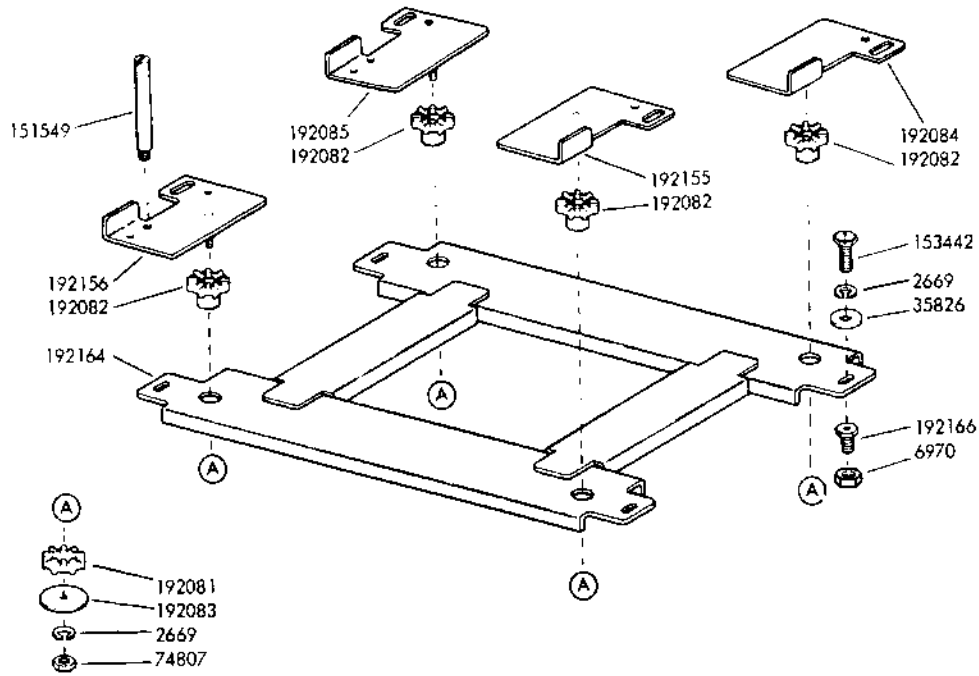

FIGURE 3. MOUNTING FRAME

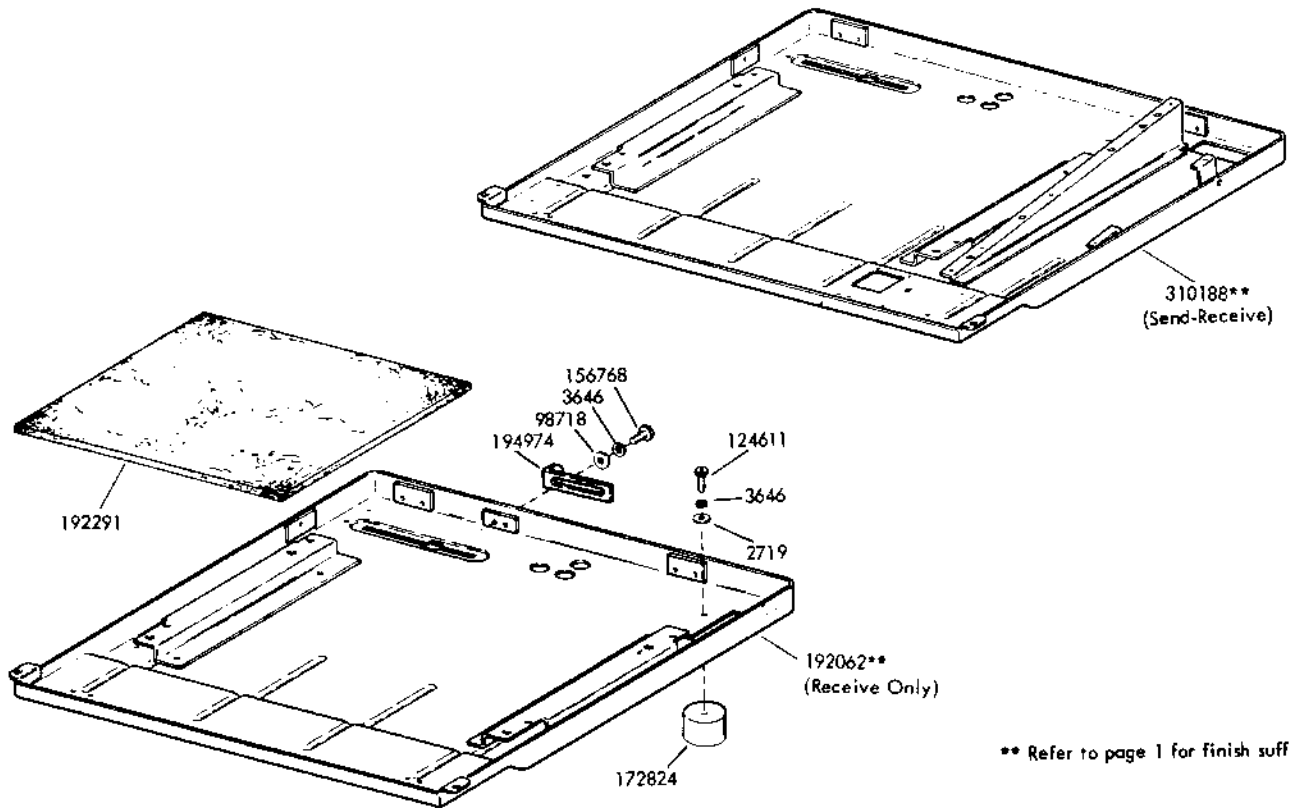

FIGURE 4. PANS - TABLE MODEL

\*\* Refer to page 1 for finish suffix

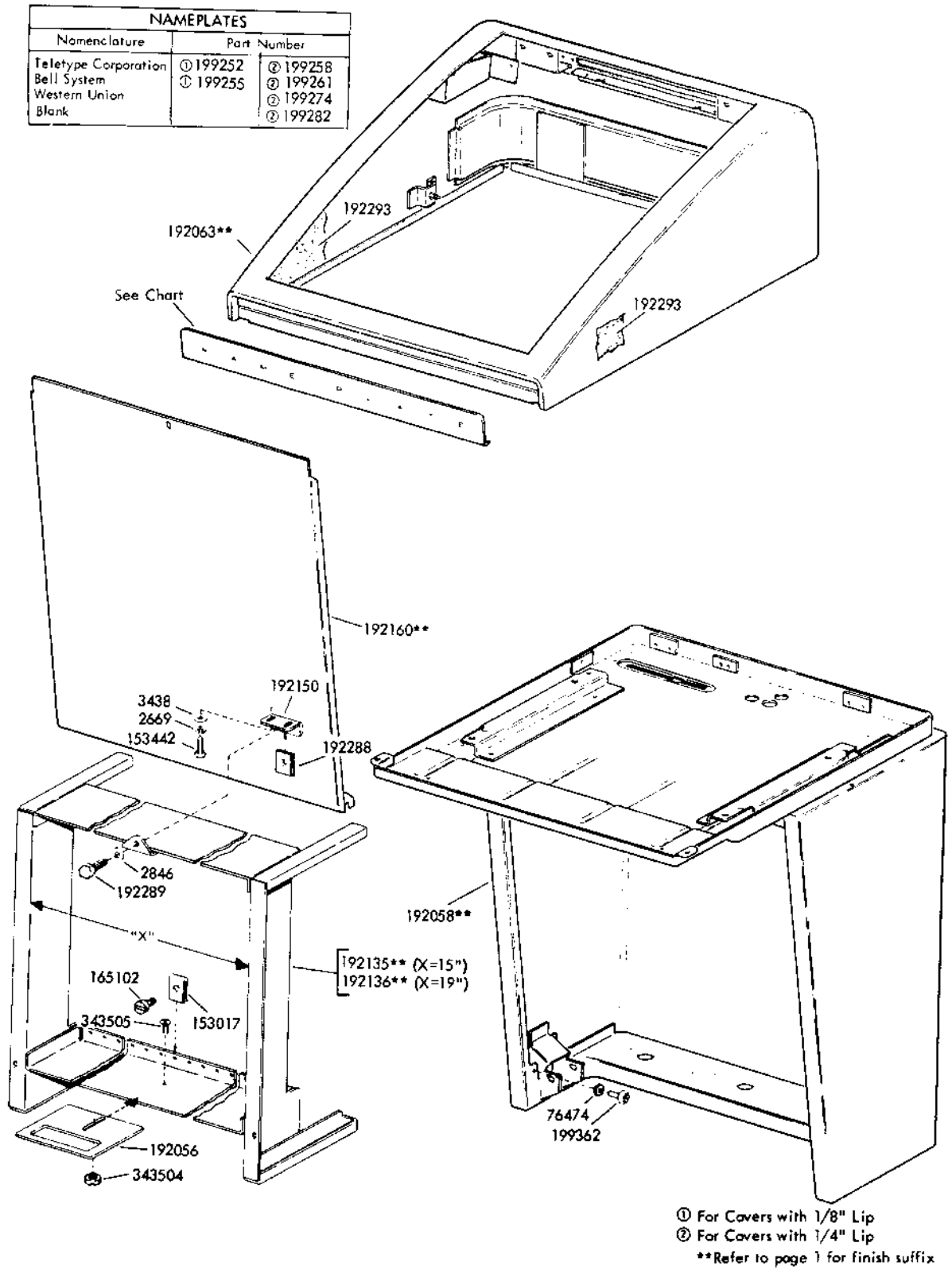
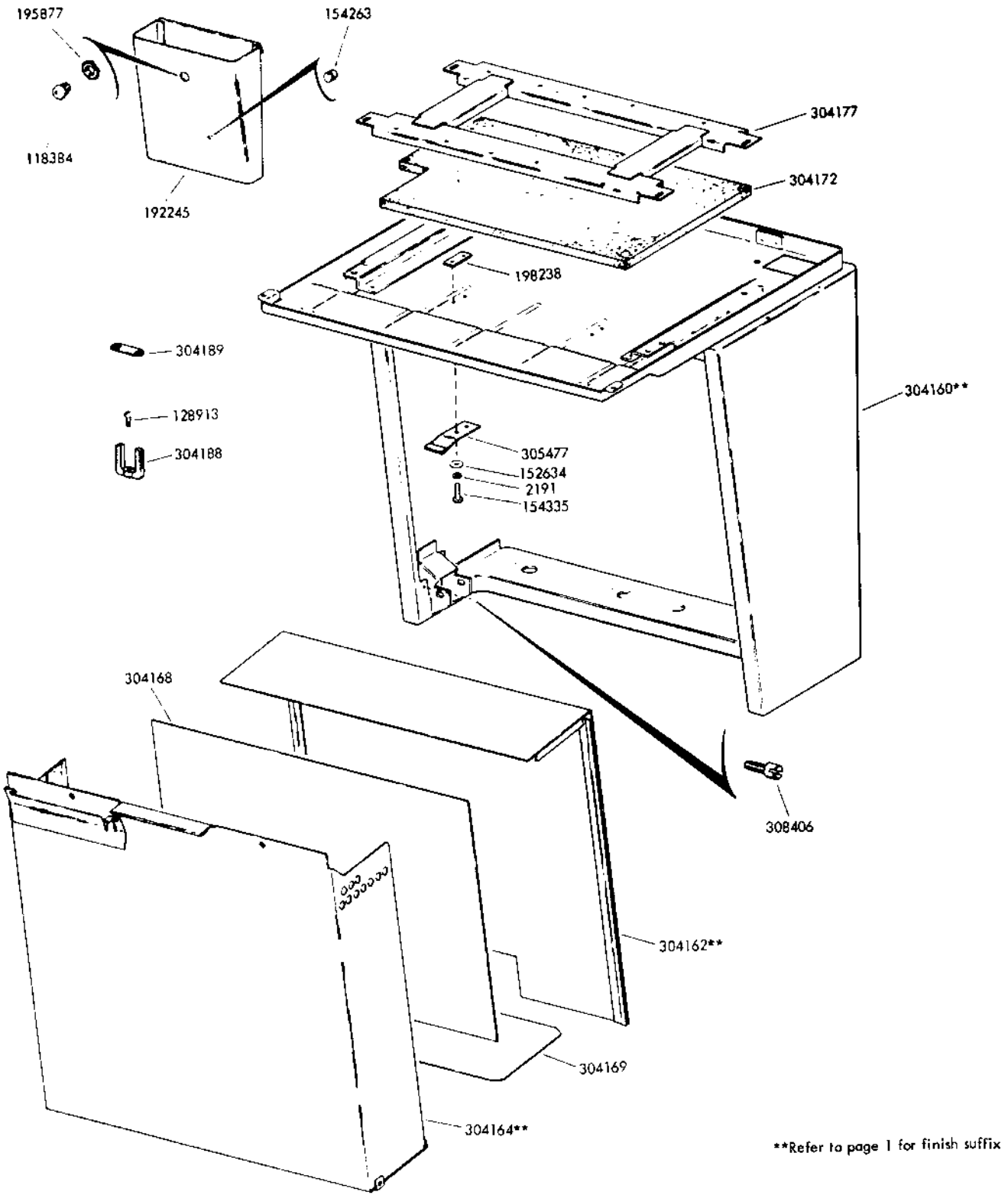
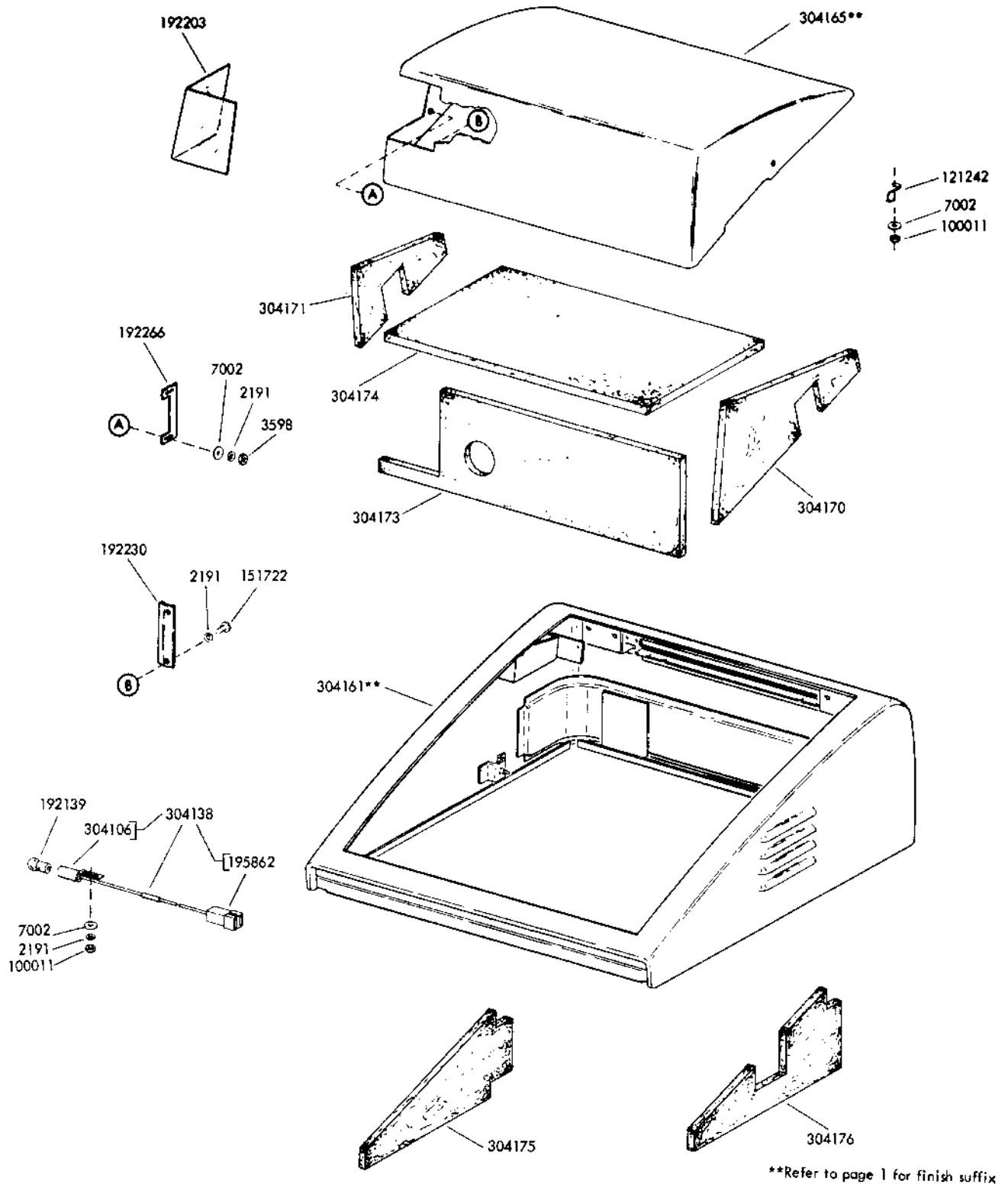

FIGURE 5. PEDESTAL AND LOWER COVER



\*\*Refer to page 1 for finish suffix

FIGURE 6. PEDESTAL



\*\*Refer to page 1 for finish suffix

FIGURE 7. UPPER AND LOWER COVER

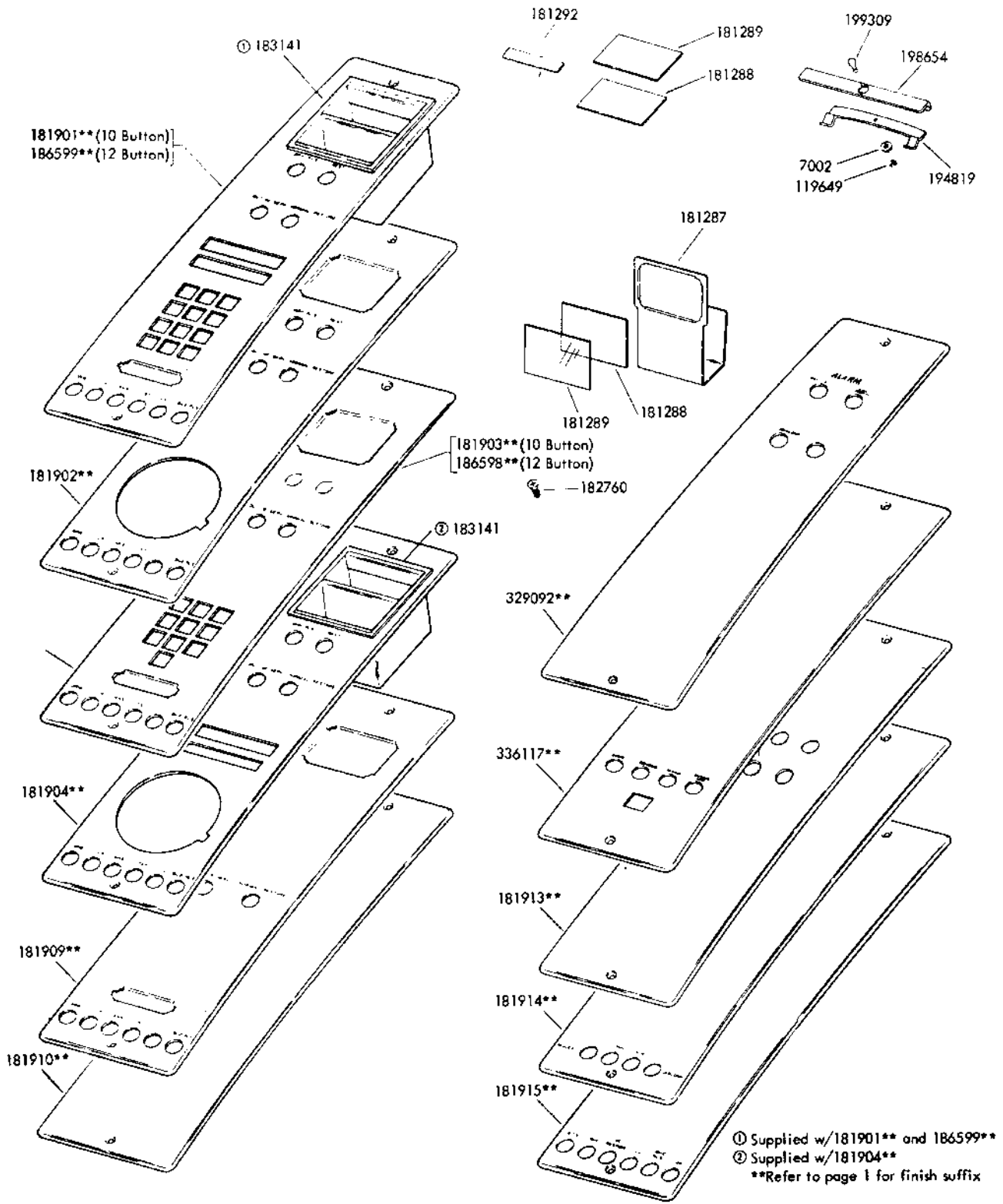
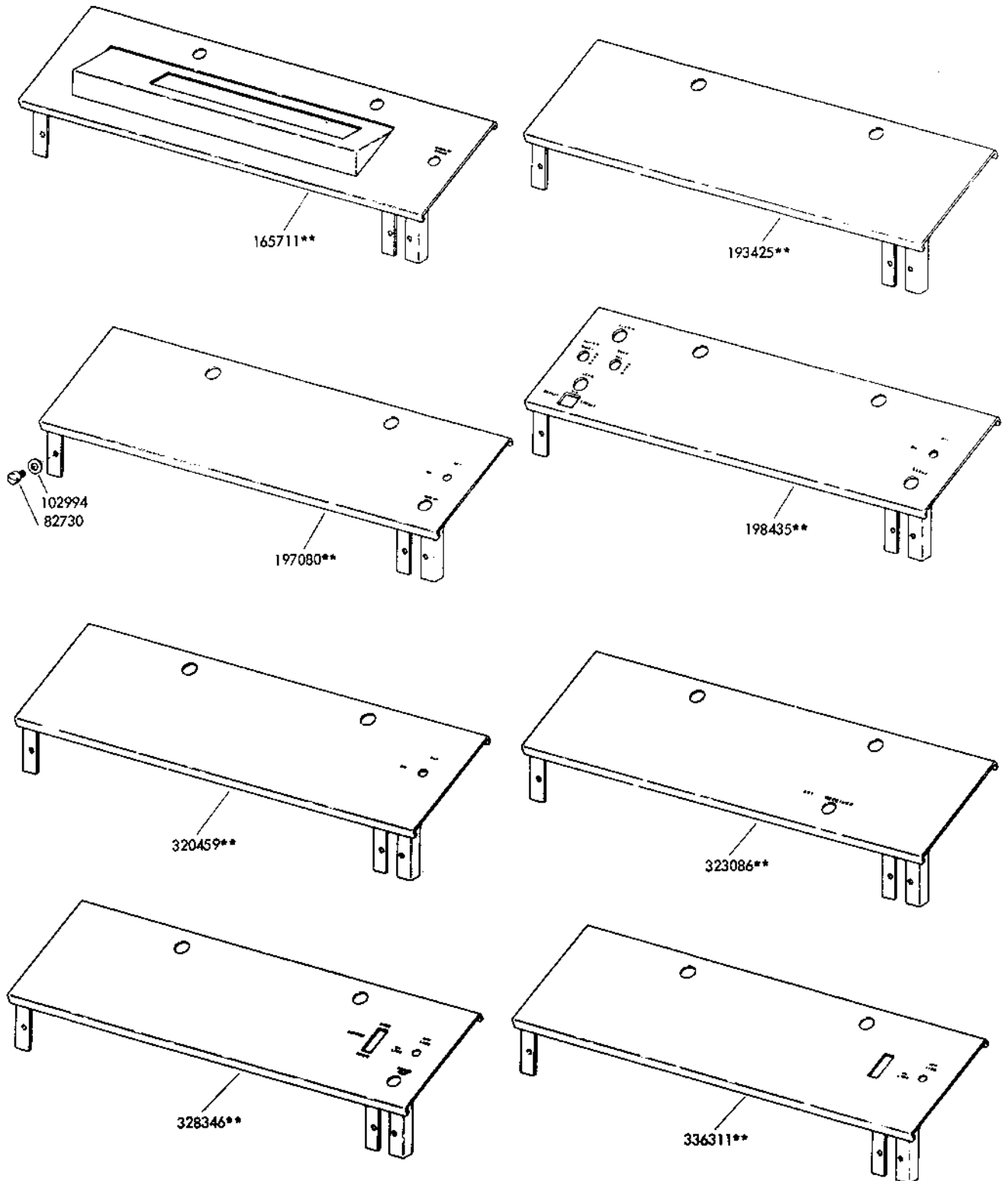

FIGURE 8. FACEPLATES





\*\*Refer to page 1 for finish suffix

FIGURE 9. CONTROL PANELS

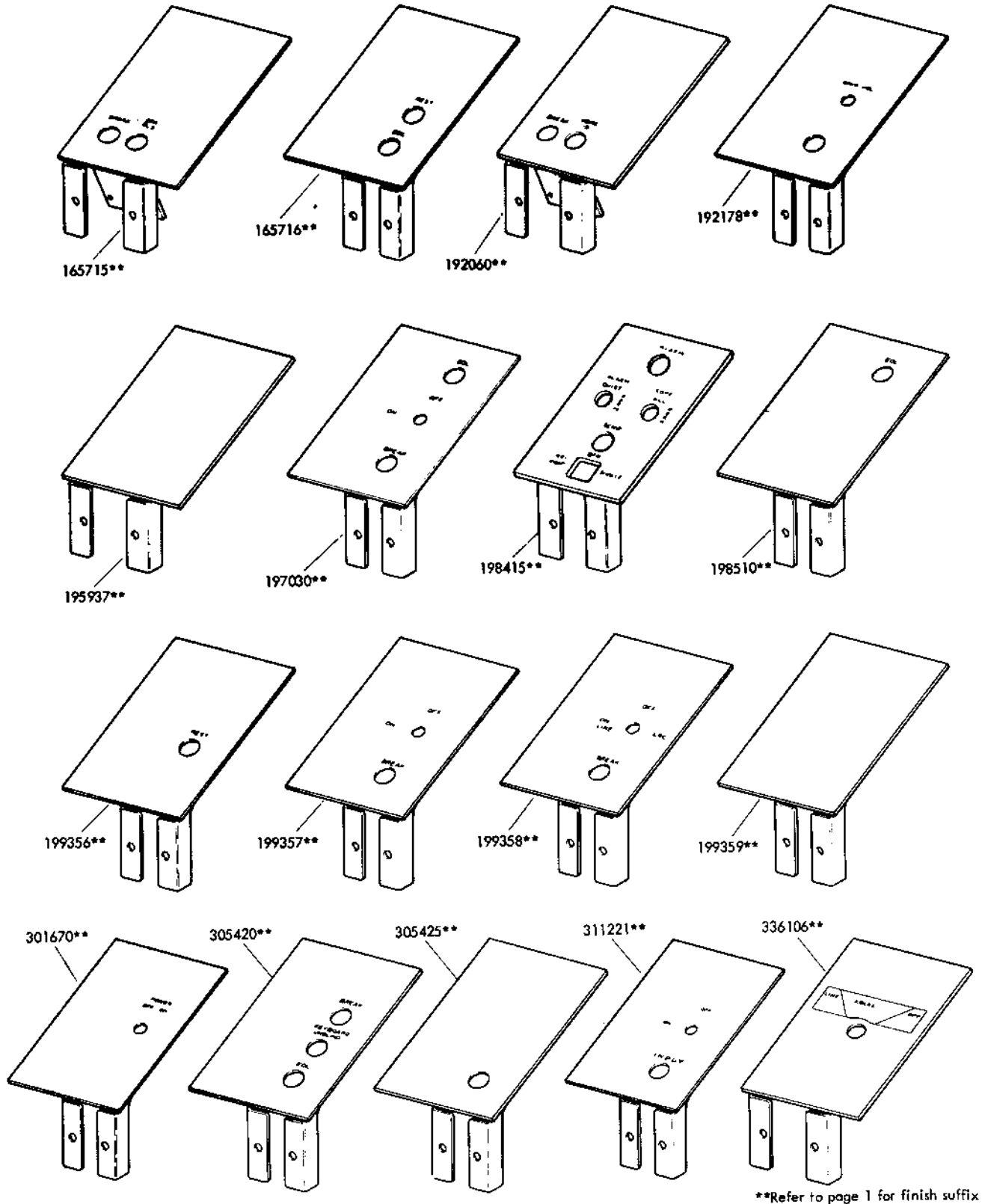

\*\*Refer to page 1 for finish suffix

FIGURE 10. CONTROL PANELS

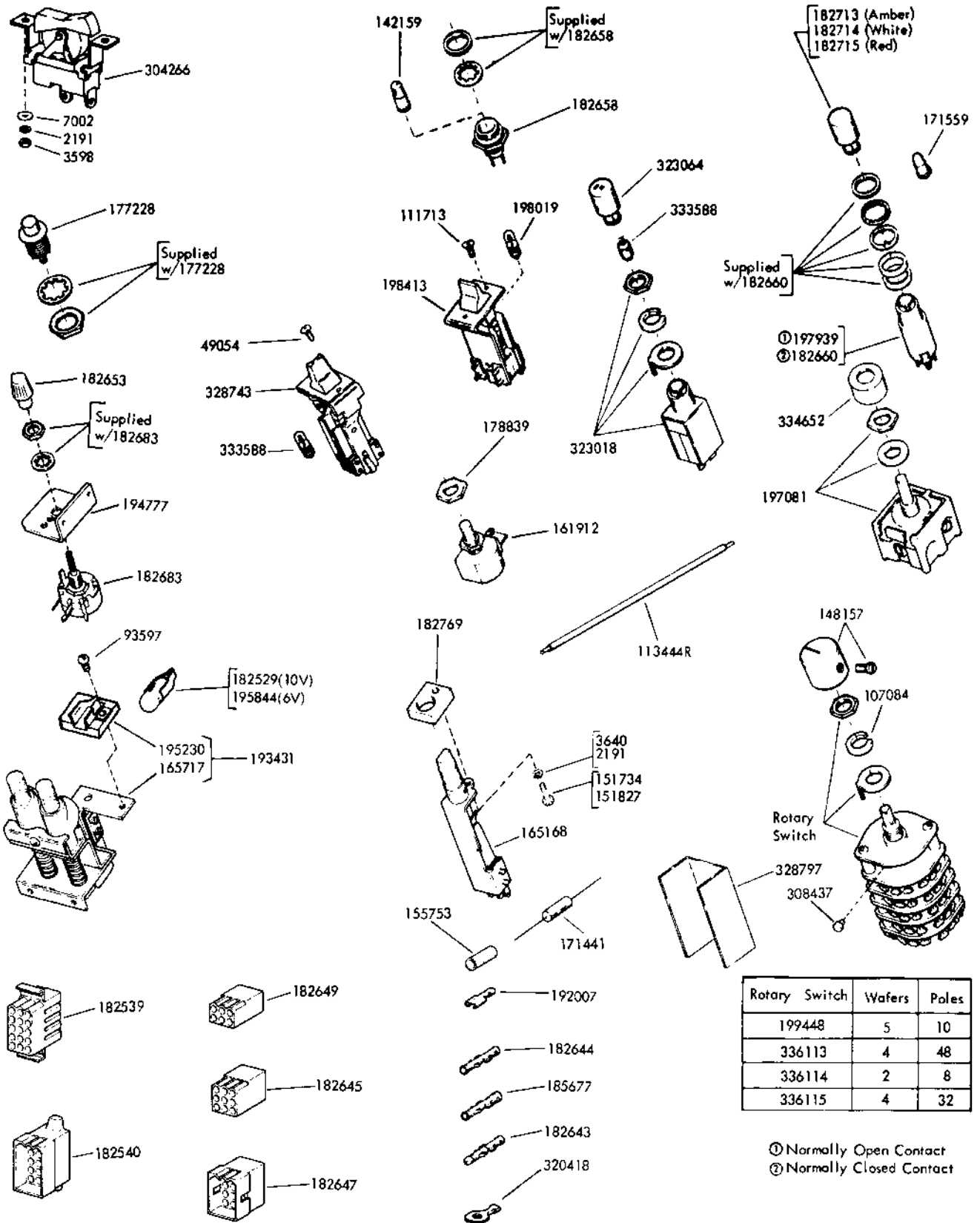

Rotary Switch	Wafers	Poles
199448	5	10
336113	4	48
336114	2	8
336115	4	32

① Normally Open Contact  
 ② Normally Closed Contact

FIGURE 11. CONTROL PANEL COMPONENTS

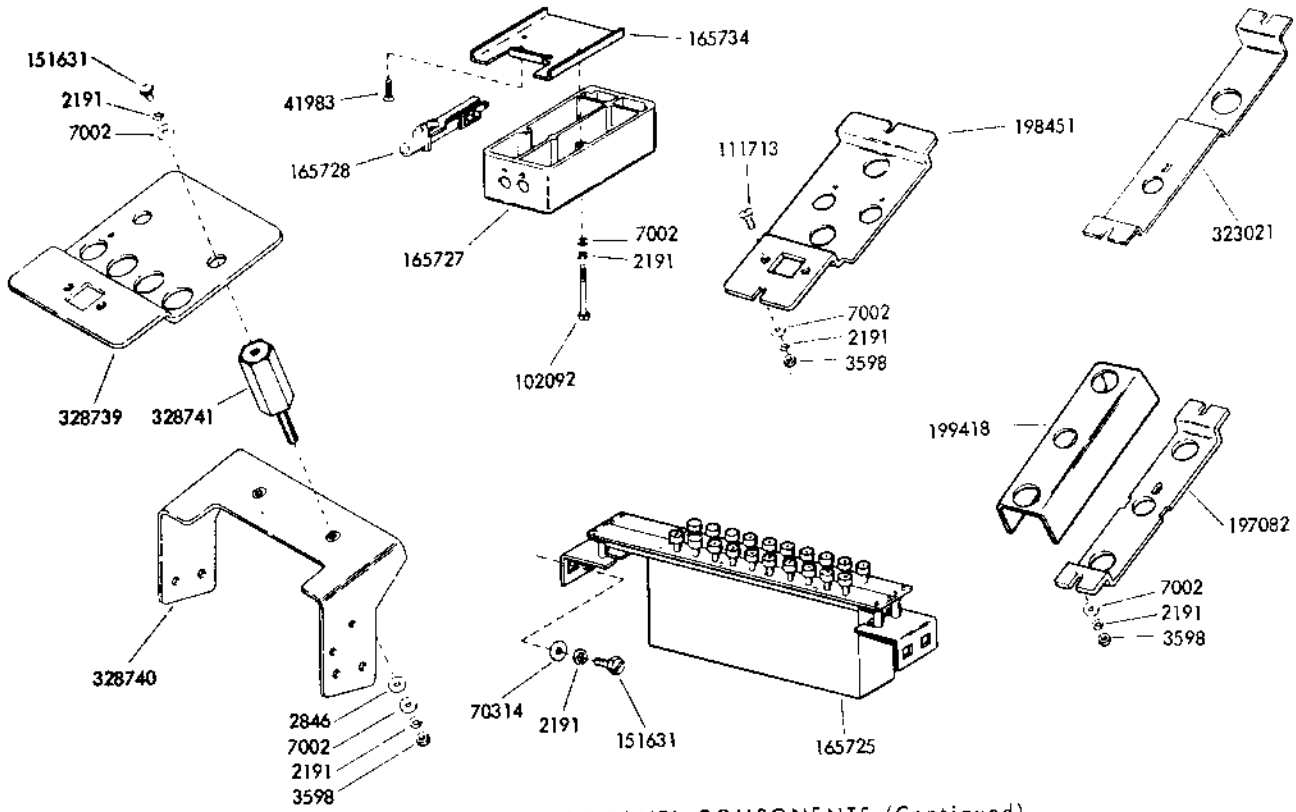
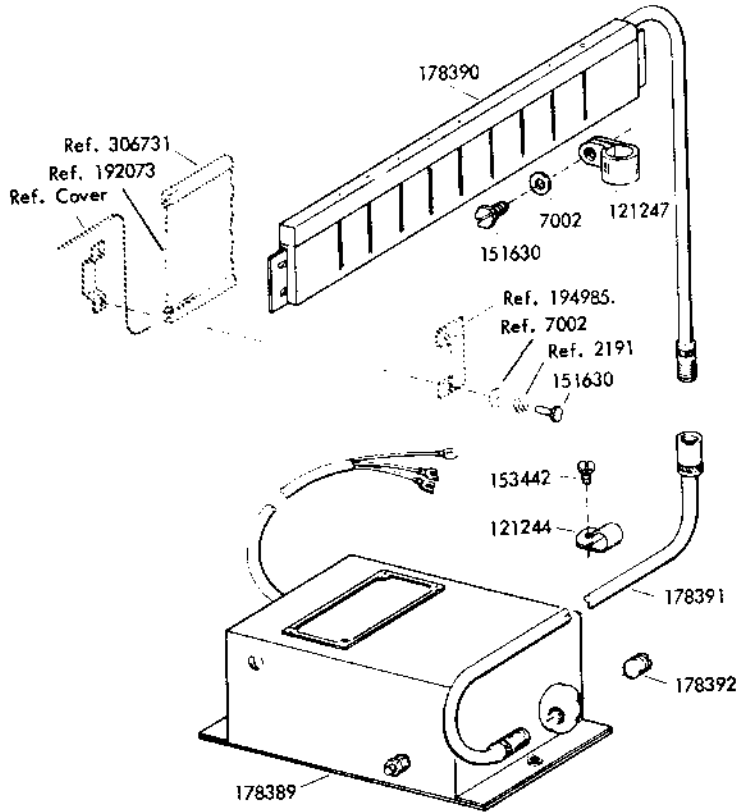

FIGURE 12. CONTROL PANEL COMPONENTS (Continued)



Specification 500515  
 \*\*Refer to page 1 for finish suffix

FIGURE 13. 178387 MODIFICATION KIT TO PROVIDE HIGH VOLTAGE STATIC ELIMINATOR TO NEUTRALIZE ELECTROSTATIC CHARGE ON PAGE COPY

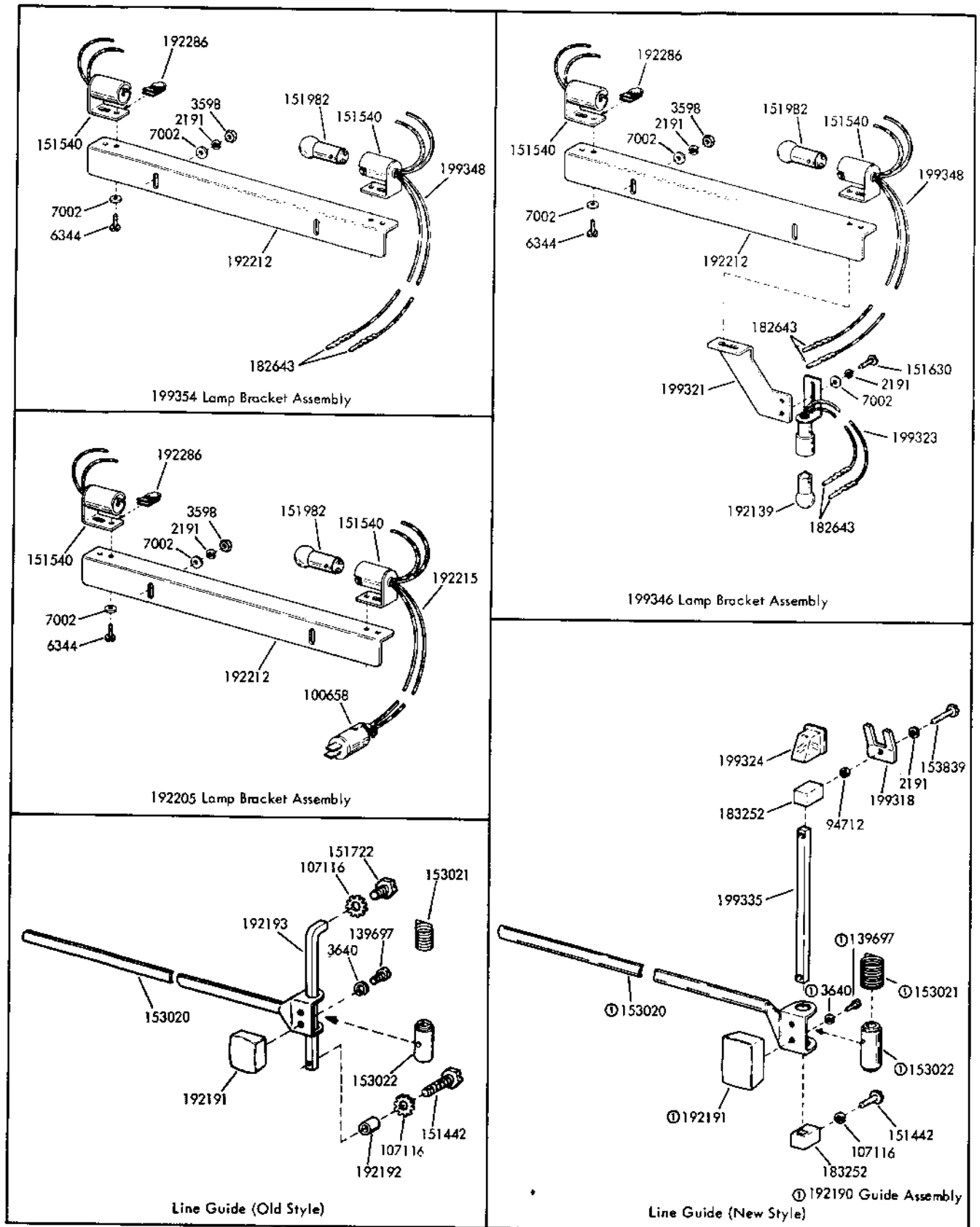

FIGURE 14. LAMP BRACKETS AND LINE GUIDES

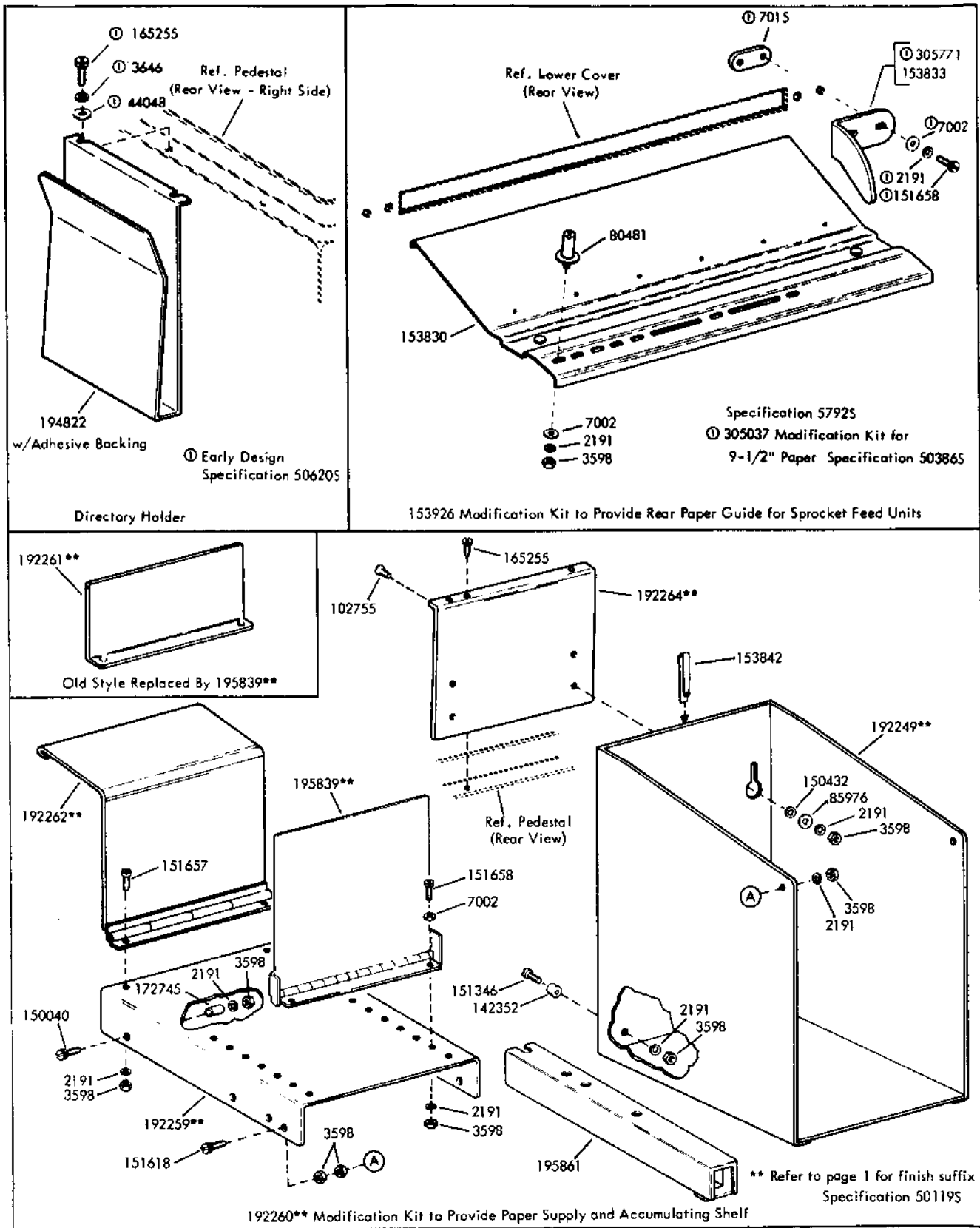

FIGURE 15. PAPER HANDLING AND DIRECTORY HOLDER MODIFICATION KITS

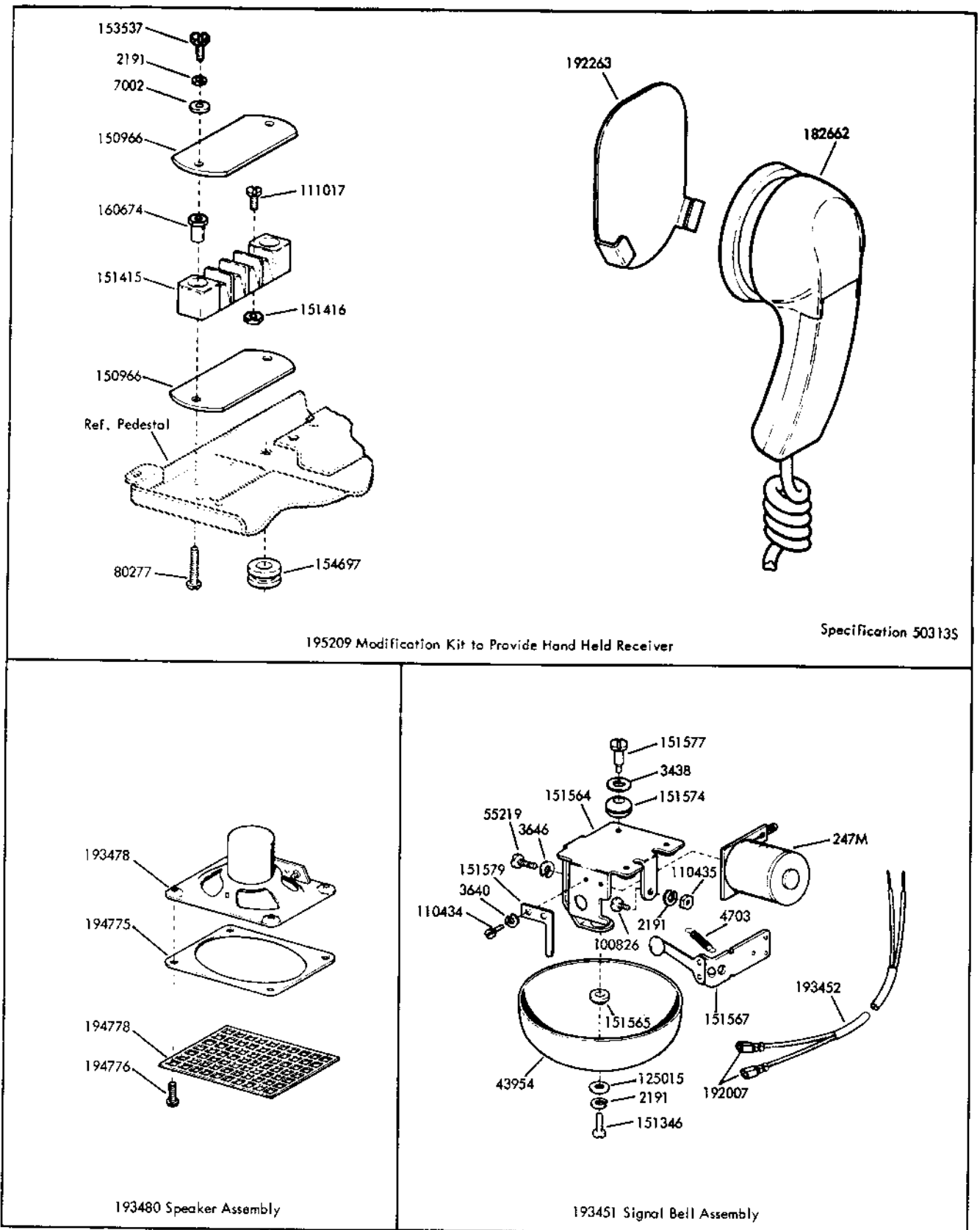
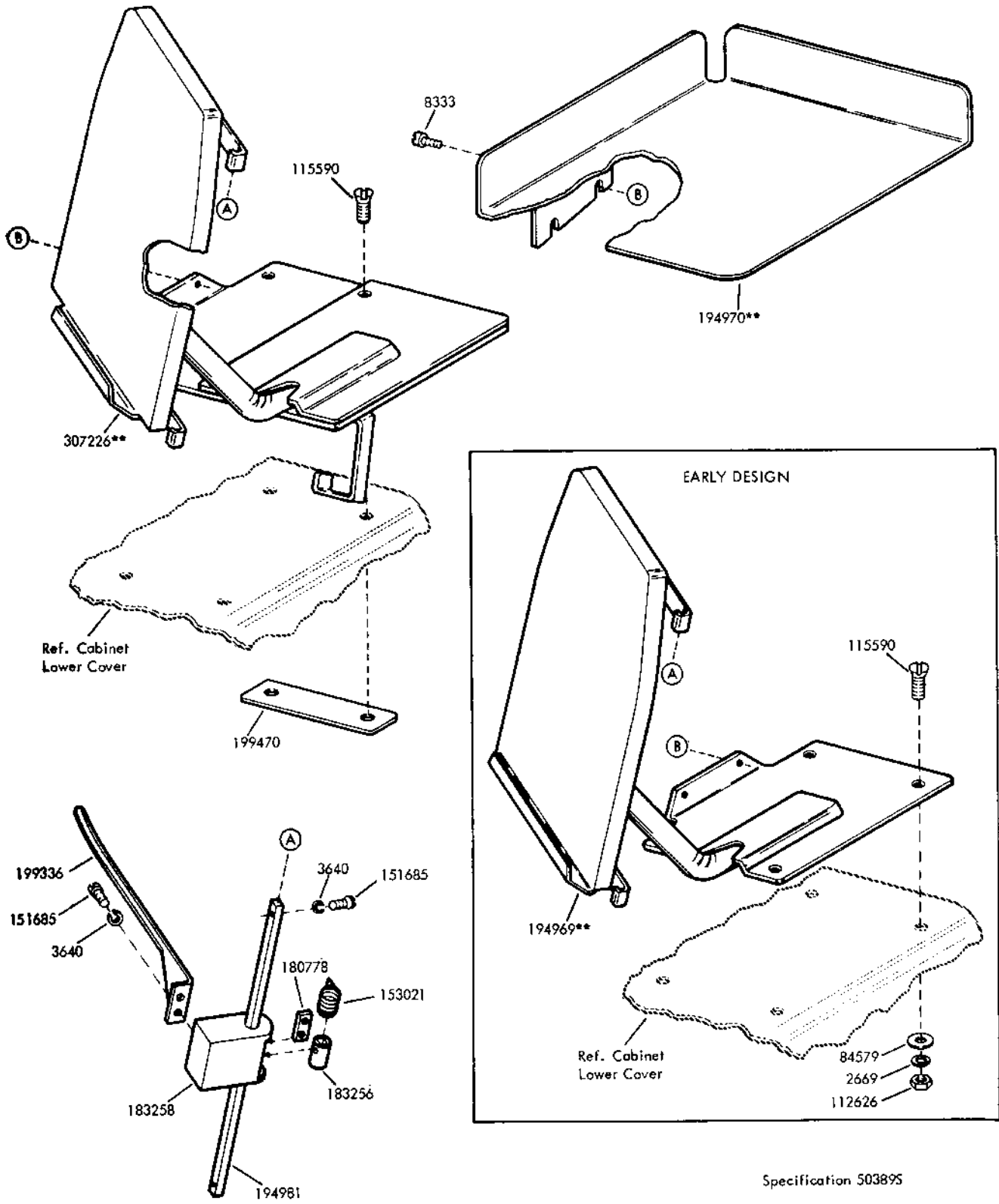

FIGURE 16. HAND HELD RECEIVER, SPEAKER AND SIGNAL BELL



\*\* Refer to page 1 for finish suffix

FIGURE 11. 307228\*\* MODIFICATION KIT TO ADD OFFSET COPYHOLDER



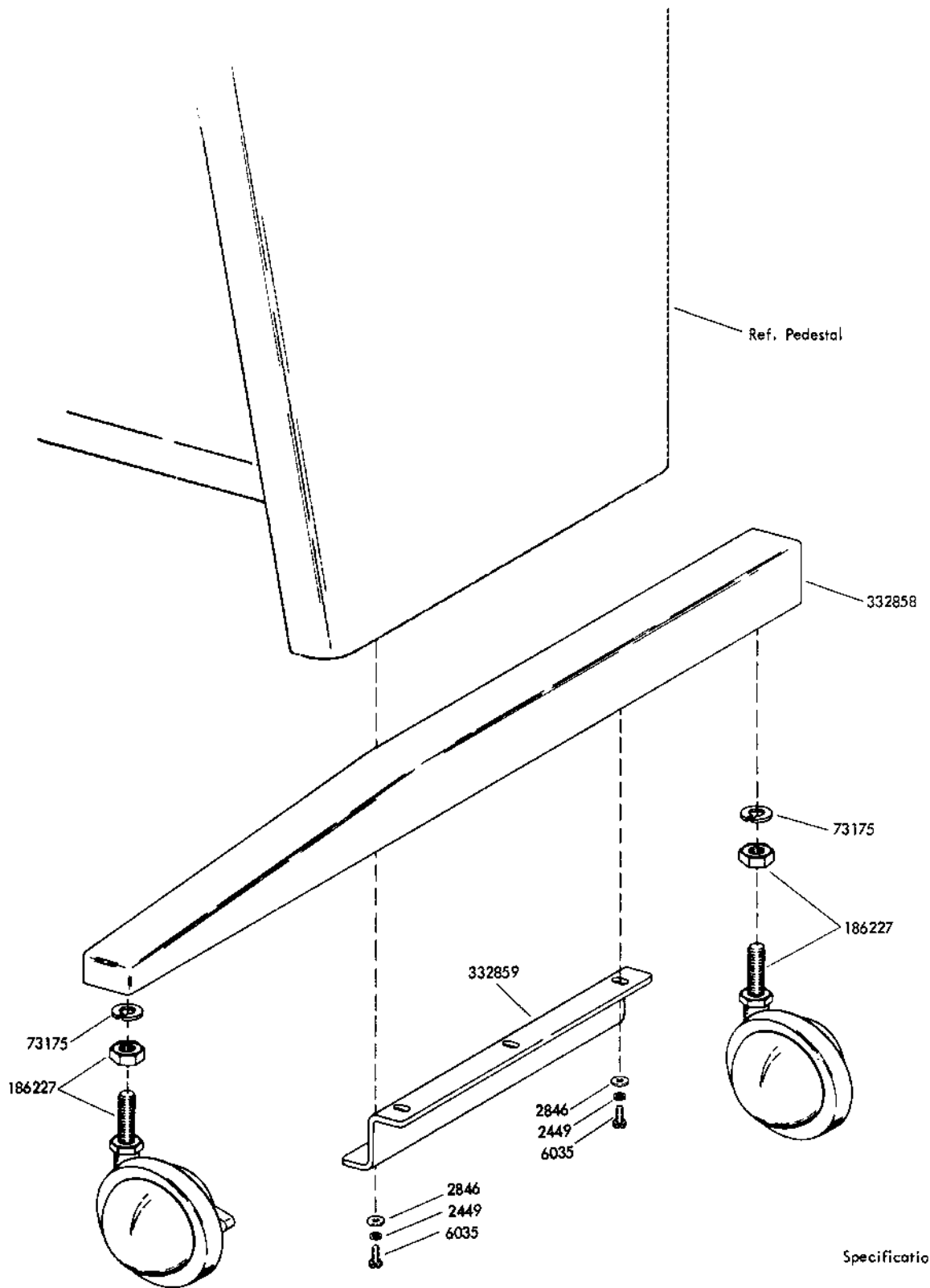

FIGURE 18. 333456 MODIFICATION KIT TO PROVIDE MOBILITY FOR CABINET

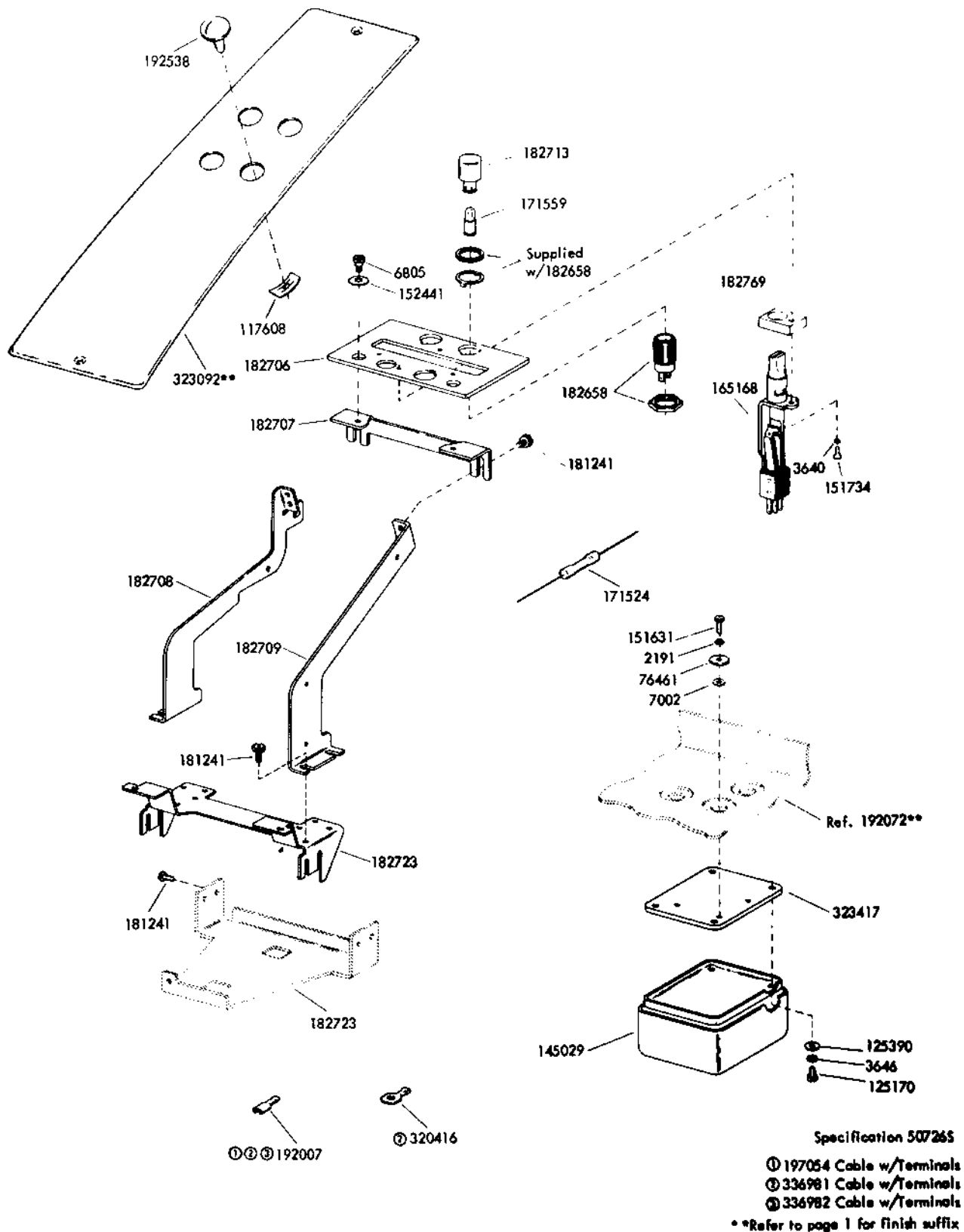

FIGURE 19. 336932 MODIFICATION KIT TO PROVIDE AUDIBLE AND VISIBLE ALARM ON LOW PAPER

## NUMERICAL INDEX

Part Number	Description and Page Number	Part Number	Description and Page Number	Part Number	Description and Page Number
247M	Coil, Magnet 15	98718	Washer, Flat 3,4	144778	Screw, No. 6 Self-Tapping 3
2034	Washer, Flat 2	100011	Nut, 6-40 Hex 2,7	145029	Buzzer 18
2191	Lockwasher 2,6,7,11,12, 13,14,15,18	100658	Connector, 2 Pt Plug 13	148157	Knob, Gray 11
2449	Lockwasher 17	100826	Screw, 4-40 x 3/16 Rd 15	150040	Screw, 6-40 x 5/8 Fil 14
2669	Lockwasher 2,3,4,5,16	101633	Washer, Flat 2,3	150432	Washer, Flat 14
2719	Washer, Flat 4	102092	Screw, 6-40 x 1-17/32 Rd 12	150966	Insulator, Terminal Block 15
2846	Washer, Flat 5,12,17	102755	Screw, 6-40 x 7/16 Flat 14	151346	Screw, 6-40 x 3/8 Fil 14, 15
3438	Washer, Flat 5,15	102994	Washer, Flat 9	151415	Block, Terminal 15
3598	Nut, 6-40 Hex 2,7,11,12, 13,14	103092	Connector, Cord 3	151416	Nut, 6-40 Hex 15
3599	Nut, 4-40 Hex 2	105029	Washer, Flat 3	151442	Screw, 6-40 x 1/2 Hex 13
3640	Lockwasher 11,13,15,16, 18,	107084	Lockwasher 11	151540	Lampholder 13
3646	Lockwasher 2,3,4,15,18	107116	Lockwasher 13	151549	Post 4
4703	Spring 15	110434	Screw, 4-40 x 3/16 Fil 15	151564	Bracket 15
6035	Screw, 1/4-20 x 5/8 Hex 17	110435	Nut, 4-40 Hex 15	151565	Bushing, Shoulder 15
6344	Screw, 6-32 x 11/32 Hex 13	110743	Lockwasher 2	151567	Armature w/Clapper 15
6805	Screw, 6-40 Shoulder 18	111017	Screw, 6-40 x 5/16 Fil 15	151574	Grommet, Rubber 15
6970	Nut, 3/8-32 Hex 4	111713	Screw, 2-56 x 5/32 Flat 11,12	151575	Arm, Stop 3
7002	Washer, Flat 2,7,8,11,12, 13,14,15,18	112626	Nut, 10-32 Hex 2,16	151577	Screw, 6-40 Shoulder 15
7015	Plate, Nut 14	113444R	Jumper, 5-1/2" Red 11	151579	Plate, Retaining 15
8333	Screw, 10-32 x 3/8 Rd 16	115590	Screw, 10-32 x 1/2 Oval 16	151618	Screw, 6-40 x 7/16 Fil 14
35826	Washer, Flat 4	116793	Lockwasher 3	151630	Screw, 6-40 x 1/4 Hex 12, 13
41983	Screw, 8-32 x 5/8 Flat 12	117535	Washer, Flat 3	151631	Screw, 6-40 x 5/16 Hex 2,12,18
43954	Bell 15	117608	Nut, Speed 18	151657	Screw, 6-40 x 1/4 Fil 2, 14
44048	Washer, Flat 14	118384	Lens, Clear Indicator Light 6	151658	Screw, 6-40 x 5/16 Fil 14
49054	Screw, 2-56 x 3/16 Flat 11	119421	Washer, Flat 3	151685	Screw, 4-40 x 5/16 Fil 16
49514	Nut, 8-32 Hex 3	119641**	Button, Plug 2	151722	Screw, 6-40 x 3/16 Hex 2, 7,13
55219	Screw, 8-32 x 3/8 Fil 15	119649	Ring, Retaining 8	151725	Screw, 10-32 x 3/4 Fil 2
70314	Washer, Flat 12	119904	Spring 3	151734	Screw, 4-40 x 3/8 Hex 11, 18
70720	Screw, 10-32 Shoulder 2,3	121242	Clamp, 1/8 ID Cable 7	151827	Strap, Terminal 11
73175	Lockwasher 17	121243	Clamp, 3/16 ID Cable 2	151982	Lamp, 6V Incandescent 13
74807	Nut, 10-32 Shoulder Hex 2,3,4	121244	Clamp, 1/4 ID Cable 12	151989	Suppressor, Electrical Noise 3
76461	Washer, Flat 18	121247	Clamp, 7/16 ID Cable 12	152441	Washer, Flat 3,18
76474	Nut, 10-32 Hex 3,5	122476	Screw, No. 6 Self-Tapping 3	152634	Washer, Flat 6
80277	Screw, 6-40 x 9/16 Rd 15	124611	Screw, 8-32 x 3/8 Hex 3,4	153017	Nut, Speed 5
80481	Screw, 6-40 Spl 14	124612	Screw, 8032 x 1/2 Hex 2	153020	Guide, Line 13
82730	Screw, 10-32 Shoulder 9	125015	Washer, Flat 15	153021	Spring, Torsion 13,16
84579	Washer, Flat 16	125170	Screw, 8-32 x 3/8 Fil 3,18	153022	Bushing 13
85976	Washer, Flat 14	125390	Washer, Flat 18	153442	Screw, 10-32 x 1/2 Hex 3,4,5,12
88891	Spring 2	128913	Screw, 8-32 Self-Tapping 3,6	153537	Screw, 6-40 x 9/32 Hex 2, 15
92527	Lockwasher 3	139697	Screw, 4-40 x 9/32 Fil 13		
93597	Screw, 4-40 x 3/16 Rd 11	142159	Bulb, 6V Lamp 11		
94660	Connector 3	142352	Foot, Mounting 14		
94712	Washer, Flat 13				
98642	Lockwasher 3				

\*\*Refer to page 1 for finish suffix

## NUMERICAL INDEX (Continued)

Part Number	Description and Page Number	Part Number	Description and Page Number	Part Number	Description and Page Number
153830	Guide, Rear 14	181289	Window, Plastic 8	186598**	Faceplate 8
153833	Bracket, Guide 14	181292	Window, Plastic 8	186599**	Faceplate 8
153839	Screw, 6-40 x 5/8 Hex 13	181901**	Faceplate 8	192007	Terminal, Tab Type 11, 15,18
153842	Clip, Paper Holder 14	181902**	Faceplate 8	192056	Handle 5
153926	Modification Kit 14	181903**	Faceplate 8	192058**	Pedestal w/Pan 5
154263	Bumper, Rubber 6	181904**	Faceplate 8	192059**	Cover, Lower 2
154335	Screw, 6-40 x 9/32 Fil 6	181909**	Faceplate 8	192060**	Plate, Key 10
154409	Plate 3	181910**	Faceplate 8	192061	Bracket, Mounting 3
154697	Grommet, Rubber 15	181913**	Faceplate 8	192062**	Pan w/Nut 4
155753	Sleeve, 1/8 ID x 1/2" Lg Insulating 11	181914**	Faceplate 8	192063**	Cover, Lower 5
156509	Washer, Flat 3	181915**	Faceplate 8	192064**	Cover, Upper 2
156768	Screw, 8-32 x 9/32 Hex 4	182529	Lamp, 10V 11	192067	Bubble 2
160664	Pin, Roll 2	182539	Connector, 15 Pt Receptacle Type 11	192068	Bracket, Right Pivot 2
160674	Nut, 6-40 Shoulder 15	182529	Lamp, 10V 11	192069	Bracket, Left Pivot 2
161912	Switch, SP-ST 11	182540	Connector, 15 Pt Plug Type 11	192070	Guide, Form 2
165102	Screw, 12-24 x 3/8 Rd 5	182643	Terminal, Plug Type 11,13	192072**	Pedestal w/Pan 3,18
165168	Key 11,18	182644	Terminal, Receptacle Type 11	192073	Window, Glass 2,12
165255	Screw, No. 8 Spl 14	182645	Connector, 9 Pt Receptacle Type 11	192074	Foot w/Nut 3
165711**	Plate, Mounting 9	182647	Connector, 12 Pt Plug Type 11	192081	Ring 4
165715**	Plate, Key 10	182649	Connector, 6 Pt Receptacle Type 11	192082	Bushing 4
165716**	Plate, Lamp 10	182653	Knob 11	192083	Washer, Flat 4
165717	Key Assembly 11	182658	Socket, Lamp 11,18	192084	Bracket, Right Rear 4
165725	Key, Locking 12	182660	Switch, Pushbutton 11	192085	Bracket, Left Rear 4
165727	Mounting, Jack 12	182662	Receiver 15	192103	Window, Plastic 2
165728	Jack 12	182683	Resistor, 50 Ohm 11	192106	Plate, Nut 3
165734	Bracket, Jack Mounting 12	182706	Plate, Pilot 18	192107	Plate, Nut 3
171441	Resistor, 560 Ohm 11	182707	Bracket, Pilot 18	192115	Pad, Upper Cover Front 2
171524	Resistor, 700 Ohm 18	182708	Bracket, Left 18	192135**	Rack, Mounting 5
171559	Lamp, 28V Incandescent 11,18	182709	Bracket, Right 18	192136**	Rack, Mounting 5
172745	Bushing, .406 Lg 14	182713	Cap, Amber Lens 11,18	192139	Lamp, 6V 7,13
172824	Foot, Rubber 4	182714	Cap, White Lens 11	192149	Plate, Latch 2
177228	Switch, Black Pushbutton 11	182715	Cap, Red Lens 11	192150	Bracket 5
178387	Modification Kit 1,12	182723	Bracket 18	192155	Bracket, Right Front 4
178389	Power Unit 12	182760	Screw, 6-32 Spl 8	192156	Bracket, Left Front 4
178390	Bar, Static Eliminator 12	182769	Block 11,18	192160**	Panel 5
178391	Cable, Inductor 12	183141	Holder, Card 8	192161**	Panel 3
178392	Plug, Outlet 12	183252	Post 13	192164	Frame 4
178707	Bumper, Rubber 2	183256	Bushing 16	192166	Plate 4
178839	Nut, 11/32-32 Hex 11	183258	Handle, Copyholder 16	192178**	Plate 10
180778	Plate 16	185677	Terminal, Receptacle Type 11	192179	Bracket, Mounting 3
180798	Screw, 8-32 Self-Tapping 3	186227	Caster 17	192190	Guide Assembly, Line 13
181241	Screw w/Lockwasher, 6-40 x 1/4 Hex 18	186540	Screw, 1/4-20 Spl 3	192191	Knob 13
181287	Holder, Card 8			192192	Bushing 13
181288	Label, White 8			192193	Shaft 13
				192203	Window, Plastic 7
				192205	Bracket Assembly, Lamp 13
				192212	Bracket, Lamp 13
				192215	Cable Assembly 13

\*\*Refer to page 1 for finish suffix

## NUMERICAL INDEX (Continued)

Part Number	Description and Page Number	Part Number	Description and Page Number	Part Number	Description and Page Number
192230	Plate, Clamp 7	194920	Latch, Lower Cover 3	199282	Nameplate 2,5
192245	Container, Chad 6	194921	Pin, Stop 3	199284	Nameplate 2
192249**	Shelf, Paper Box 14	194966	Latch, Right Dome 2	199307	Guide 2
192256	Hinge, Left 2	194969**	Copyholder 16	199308	Guide 2
192259**	Shelf, Paper 14	194970**	Tray 16	199309	Stud 8
192261**	Bracket, Backstop 14	194974	Bracket, Stop 4	199318	Clamp 13
192262**	Plate, Deflector 14	194980	Latch, Left Dome 2	199321	Bracket 13
192263	Holder, Handset 15	194981	Shaft, Line Guide 16	199323	Cable Assembly 13
192264**	Plate, Mounting 14	194983	Retainer 2	199324	Cover, Lamp 13
192266	Plate 7	194984	Screw, No. 6 x 1-1/2 Spl 3	199335	Shaft 13
192267	Button 2	194985	Clamp 2,12	199336	Guide, Line 16
192271	Plate, Nut 3	194987	Screw, 8-32 x 3/8 Hex 3	199337	Retainer 3
192273	Nut, Speed 3	194988	Screw, 10-32 Spl 2	199346	Bracket Assembly, Lamp 13
192274	Screw, 8-32 Spl 3	195209	Modification Kit 15	199348	Cable Assembly 13
192276	Hinge, Right 2	195230	Strip, Lamp 11	199354	Bracket Assembly, Lamp 13
192278	Arm, Right Counter Balance 2	195629	Plate 2	199356**	Plate, Lamp 10
192279	Arm, Left Counter Balance 2	195839**	Bracket, Backstop 14	199357**	Plate w/Studs 10
192281	Bracket 3	195844	Lamp, 6V 11	199358**	Plate w/Studs 10
192286	Nut, Speed 2,13	195861	Extension, Foot 14	199359**	Plate w/Studs 10
192287	Fastener, Pushbutton 3	195862	Connector, 2 Pt Plug 7	199362	Post, Pivot 3,5
192288	Nut, No. 14 Speed 5	195872	Label 2	199418	Insulator 12
192289	Screw, 1/4-14 Self-Tapping 5	195877	Nut, 9/16-27 Hex 6	199448	Switch, Rotary 11
192291	Pad, Base 3,4	195937**	Plate 10	199470	Plate, Nut 16
192293	Pad, Lower Cover Side 2,5	197028	Terminal 3	301664	Coverplate 3
192296	Pad, Upper Cover Side 2	197030**	Plate w/Studs 10	301670**	Plate 10
192538	Plug, Button 18	197054	Jumper, 3" Black 18	304106	Socket, Lamp 7
193425**	Plate 9	197080**	Plate 9	304138	Cable Assembly 7
193431	Key Assembly 11	197081	Switch, 3 Position 11	304160**	Pedestal w/Pan 6
193451	Bell Assembly, Signal 15	197082	Bracket, Switch 12	304161**	Cover, Lower 7
193452	Cable w/Terminals 15	197939	Switch, Pushbutton 11	304162**	Panel 6
193478	Speaker 15	198019	Lamp, 6V 11	304164**	Panel 6
193480	Speaker Assembly 15	198238	Plate, Nut 6	304165	Cover, Upper 7
194775	Spacer, .050" Thk 15	198413	Switch, Lever 11	304168	Insulator 6
194776	Screw, 6-32 Spl 3,15	198415**	Plate w/Studs 10	304169	Insulator 6
194777	Bracket, Switch 11	198435**	Plate 9	304170	Pad, Right Cover 7
194778	Grille, Speaker 15	198451	Bracket, Switch 12	304171	Pad, Left Cover 7
194819	Clip, Spring 8	198510**	Plate w/Studs 10	304172	Pad, lower 6
194822	Holder, Directory 14	198654	Bracket, Locating 8	304173	Pad, Front Cover 7
194823	Plate, Nut 2	199251	Nameplate 2	304174	Pad, Top Cover 7
194902	Bracket, Stop 3	199252	Nameplate 5	304175	Pad, Left Cover 7
194904	Hinge w/Pin 2	199254	Nameplate 2	304176	Pad, Right Cover 7
194905	Bracket, Hinge 3	199255	Nameplate 5	304177	Frame 6
194911	Lockwasher 3	199257	Nameplate 2	304188	Clamp 6
194912	Screw, 10-32 Shoulder 3	199258	Nameplate 5	304189	Keeper 6
194913	Nut, 10-32 Acorn 2,3	199260	Nameplate 2	304266	Switch, Rocket 11
194919	Bracket, Latch 3	199261	Nameplate 5	305037	Modification Kit 14
		199273	Nameplate 2	305058	Guide, 10" Form 2
		199274	Nameplate 5	305420**	Plate, Lamp 10
				305425**	Plate, Lamp 10

\*\*Refer to page 1 for finish suffix

## NUMERICAL INDEX (Continued)

Part Number	Description and Page Number	Part Number	Description and Page Number	Part Number	Description and Page Number
305477	Latch 6	321094**	Shield, Anti-Glare 2	333456	Modification Kit 1,17
305725	Spring, Stop 3	323018	Switch, Pushbutton 11	333588	Lamp, 28V Miniature 11
305771	Bracket, Guide 14	323021	Bracket 12	334652	Insulator, Switch 11
306670	Guide, 3-5/8" Form 2	323064	Pushbutton 11	336106**	Plate w/Studs 10
306685	Guide, 9" Form 2	323086**	Plate 9	336113	Switch, Rotary 11
306731	Gasket 2,12	323091	Bracket 3	336114	Switch, Rotary 11
307226**	Copyholder 16	323092	Plate 18	336115	Switch, Rotary 11
307228**	Modification Kit 1,16	323417	Plate 18	336117**	Faceplate 8
308406	Armature w/Disk 6	328346**	Plate 9	336311**	Plate 9
308435	Bracket, Mounting 3	328739	Plate, Switch 12	336932	Modification Kit 1,18
308437	Pin, Shoulder 11	328740	Bracket, Mounting 12	336981	Cable w/Terminals 18
310188**	Pan 4	328741	Post 12	336982	Cable w/Terminals 18
311221**	Plate w/Studs 10	328743	Switch, Lever 11	343504	Bushing, Shoulder 5
312276**	Cover, Upper 2	328797	Insulator 11	343505	Rivet 5
320416	Terminal, Ring Type 18	329092**	Faceplate 8	343797	Pad 2
320418	Terminal, Ring Type 3,11	332858	Foot 17	343798**	Shield Assembly, Anti-Glare 2
320459**	Plate 9	332859	Bracket 17		

\*\*Refer to page 1 for finish suffix

35 WALL MOUNTED CABINET (LPC)  
KSR/RO  
PARTS

FIGURE	CONTENTS	PAGE
1	Cover	2
2	178543** Copyholder Tray Assembly	3
3	195782** Hood Assembly	3
4	176950 Back Plate Assembly	4
	Numerical Index	5

PAINT FINISH COLOR CODE CHART (for parts and assemblies requiring a paint finish)									
Color	Finish Suffixes				Color	Finish Suffixes			
	Wrinkle Finish	Smooth Finish	Textured Vinyl	Smooth Vinyl		Wrinkle Finish	Smooth Finish	Textured Vinyl	Smooth Vinyl
Beige		ET			Gray, Federal		BV	GG	
Beige, Light		EL		HC	Gray, Green	AB	BK	GA	
Beige, Rose		ER			Gray, Light		EJ		HB
Black	AA				Gray, Covert				HE
Black, High Gloss		BA			Gray, Olive		EW	GE	HF
Black, Semi Gloss		BB			Gray, Maritime Deck	AJ	BJ		
Blue, Aqua		EK			Gray, Oxford		EP		
Blue, Brussels Light		EC			Green, Gray	AB	BK	GA	
Blue, Medium		ES			Green, Moss		EN		HD
Brown, Dark	AD				Ivory		EM		
Brown, Light	AC				Pink, Rose		EU		
Fawn				HG	Turquoise		EV		
Gray, Beige			GC		White		EH		
Gray, Charcoal	AL	BZ	GF	HA	Yellow, Pastel		EG		
Gray, Dark			GB						

The double asterisk (\*\*) denotes a painted part. Suffix to be applied following the part number.

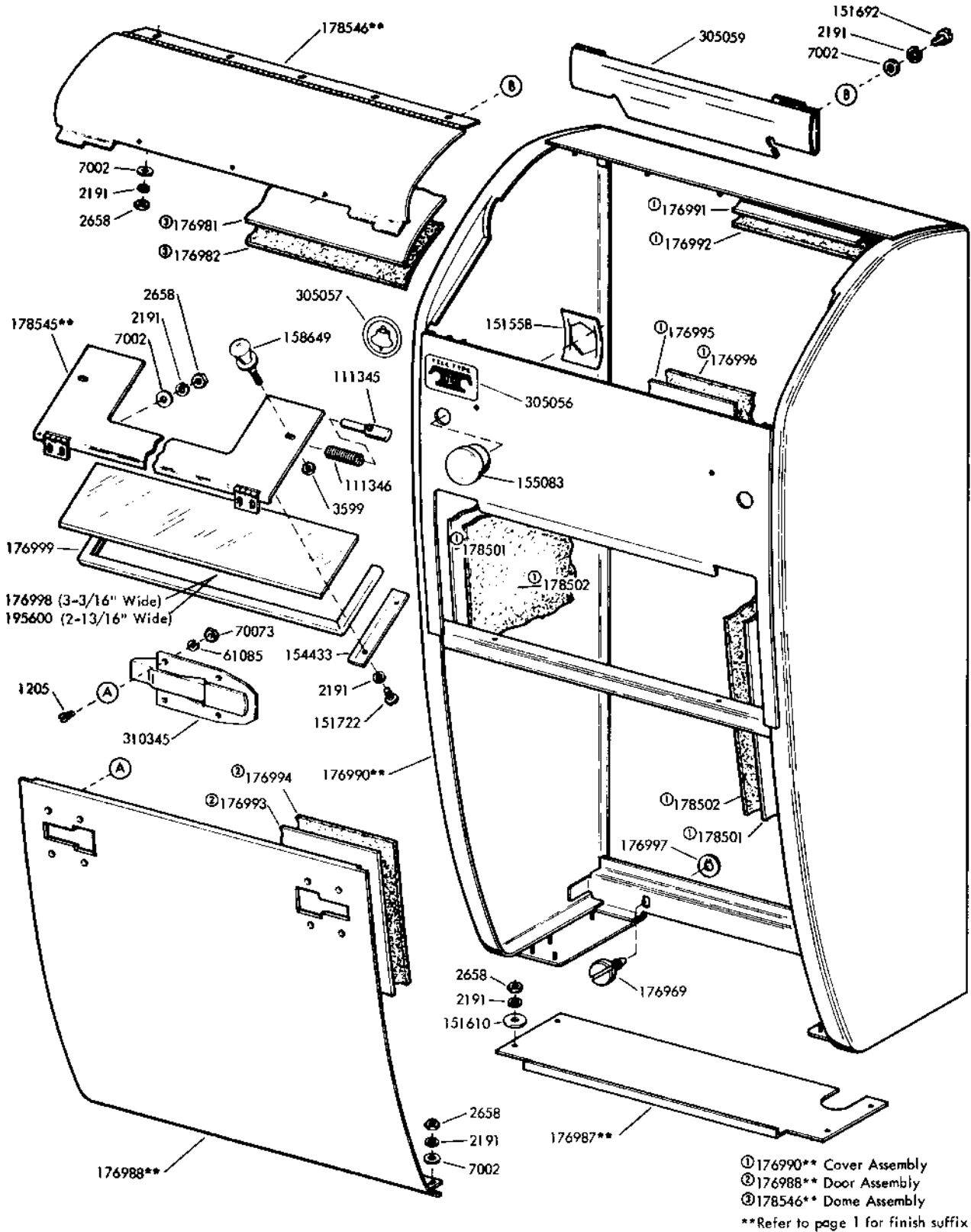

FIGURE 1. COVER



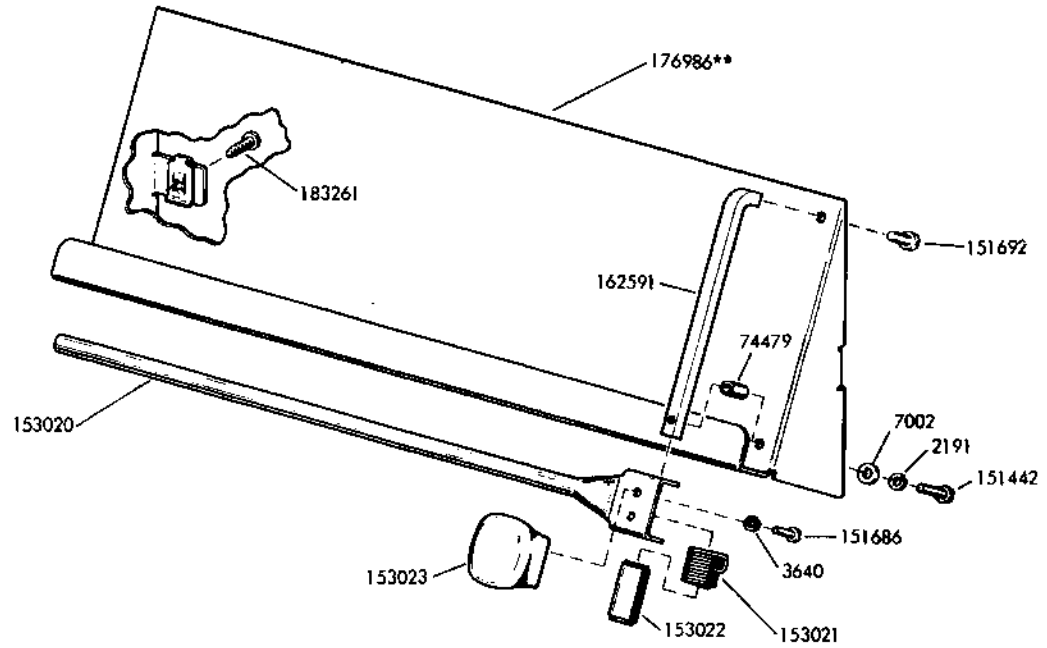
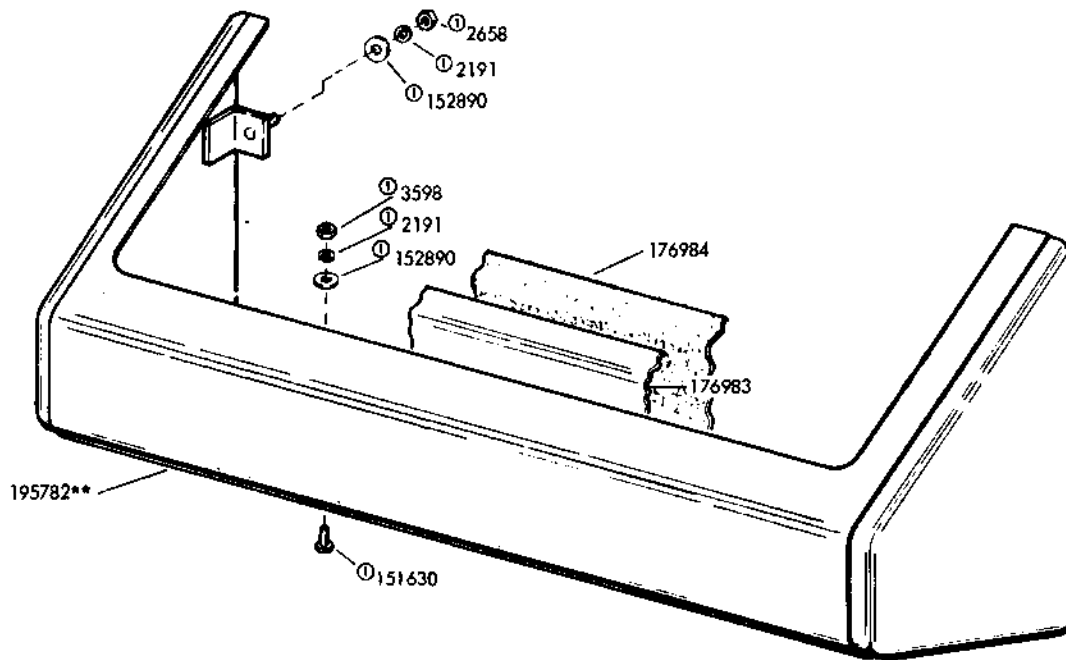

FIGURE 2. 178543\*\* COPYHOLDER TRAY ASSEMBLY



Ⓞ Not Part of 195782\*\* Hood Assembly  
 \*\*Refer to page 1 for finish suffix

FIGURE 3. 195782\*\* HOOD ASSEMBLY

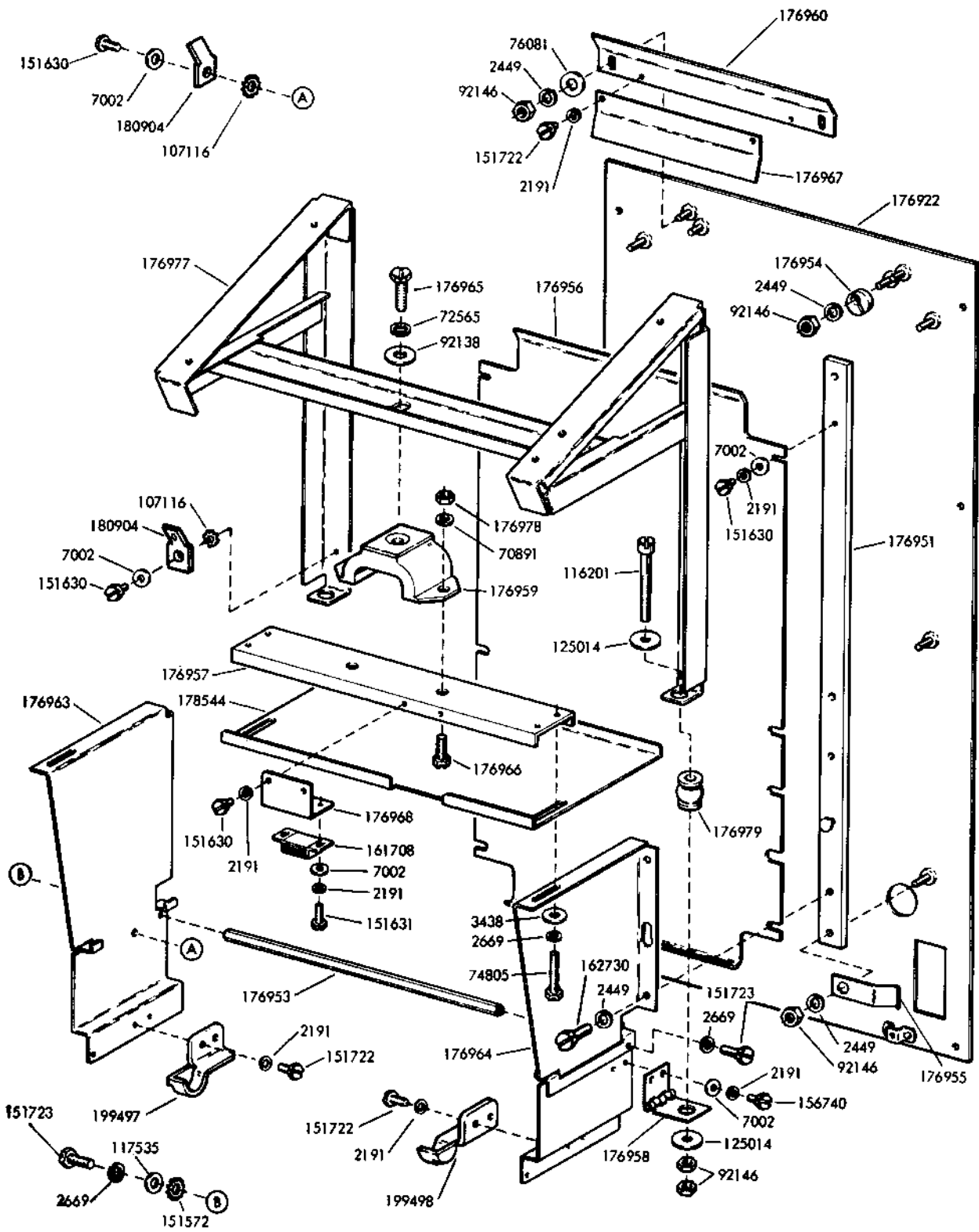

FIGURE 4. 176950 BACK PLATE ASSEMBLY

## NUMERICAL INDEX

Part Number	Description and Page Number	Part Number	Description and Page Number	Part Number	Description and Page Number
1205	Screw, 3-48 x 19/64 Flat 2	152890	Washer, Flat 3	176981	Pad, Dome 2
2191	Washer, Lock 2, 3, 4	153020	Guide, Line 3	176982	Pad, Dome 2
2449	Washer, Lock 4	153021	Spring, Torsion 3	176983	Pad, Hood 3
2658	Nut, 6-32 Hex 2, 3	153022	Bushing 3	176984	Pad, Hood 3
2669	Washer, Lock 4	153023	Handle 3	176986**	Tray, Copyholder 3
3438	Washer, Flat 4	154433	Clamp 2	176987**	Plate, Bottom 2
3598	Nut, 6-40 Hex 3	155083	Lens, Red Indicator Light 2	176988**	Door 2
3599	Nut, 4-40 Hex 2	156740	Screw, 6-40 x 7/32 Hex 4	176990**	Cover, Wall Mount
3640	Washer, Lock 3	158649	Screw, 4-40 Thumb 2	176991	Pad, Dome 2
7002	Washer, Flat 2, 3, 4	161708	Latch, Magnetic 4	176992	Pad, Dome 2
61085	Washer, Lock 2	162591	Shaft 3	176993	Pad, Door 2
70073	Nut, 3-48 Hex 2	162730	Screw, 1/4-20 x 7/16 Hex 4	176994	Pad, Door 2
70891	Washer, Lock 4	176922	Plate, Back 4	176995	Pad, Front 2
72565	Washer, Lock 4	176950	Plate Assembly, Back 1, 4	176996	Pad, Front 2
74479	Bushing 3	176951	Bar, Vertical Mounting 4	176997	Retainer 2
74805	Screw, 10-32 x 3/4 Hex 4	176953	Bar 4	176998	Window, Glass 2
76081	Washer, Flat 4	176954	Eccentric 4	176999	Gasket, Window 2
92138	Washer, Flat 4	176955	Clip, Spring 4	178501	Pad, Side 2
92146	Nut, 1/4-20 Hex 4	176956	Chute, Paper 4	178502	Pad, Side 2
107116	Washer, Lock 4	176957	Bar, Lower Support 4	178543**	Tray Assembly, Copyholder 1, 3
111345	Bolt 2	176958	Hinge 4	178544	Tray, Oil 4
111346	Spring, Compression 2	176959	Isolator 4	178545**	Door 2
116201	Screw, 1/4-20 x 1-1/2 Fil 4	176960	Bar, Cover Mounting 4	178546**	Dome, Front 2
117535	Washer, Flat 4	176963	Plate, Left Side 4	180904	Tab, Terminal 4
125014	Washer, Flat 4	176964	Plate, Right Side 4	183261	Screw, #8 Self-Tapping 3
151442	Screw, 6-40 x 1/2 Hex 3	176965	Screw, 1/2-13 x 1 Hex 4	195600	Window 2
151558	Nut, Speed 2	176966	Screw, 3/8-24 x 3/4 Hex 4	195782**	Hood w/Studs 1, 3
151572	Washer, Lock 4	176967	Deflector, Paper 4	199497	Block, Left 4
151610	Washer, Flat 2	176968	Bracket 4	199498	Block, Right 4
151630	Screw, 6-40 x 1/4 Hex 3, 4	176969	Screw, Fastener 2	305056	Plate, Identification 2
151631	Screw, 6-40 x 5/16 Hex 4	176977	Frame 4	305057	Plate, Identification 2
151686	Screw, 4-40 x 3/8 Fil 3	176978	Nut, 3/8-24 Hex 4	305059	Guide, 9-1/2" Form 2
151692	Screw, 6-40 x 3/16 Fil 2, 3	176979	Mount, Vibration 4	310345	Latch, Flush 2
151722	Screw, 6-40 x 3/16 Hex 2, 4				
151723	Screw, 10-32 x 3/8 Hex 4				

\*\*Refer to page 1 for finish suffix