

**BULLETIN 310B
VOL 1**

**TECHNICAL MANUAL
33 TELETYPEWRITER SETS
RECEIVE-ONLY (RO)
KEYBOARD SEND-RECEIVE (KSR)
AUTOMATIC SEND-RECEIVE (ASR)**



**TELETYPE®
CORPORATION**

5555 TOUHY AVENUE, SKOKIE, ILLINOIS

310B
VOLUME 1



INTRODUCTION

Bulletin 310B is a technical manual that provides general and specific information about the 33 Receive-Only (RO), Keyboard Send-Receive (KSR), and Automatic Send-Receive (ASR) Teletypewriter Sets and their component units. Change 3 is issued to provide consolidated information, reflect the latest engineering changes, and include a new optional features section.

Volume 1 contains a description of the 33 Teletypewriter Sets and gives installation instructions. Also included in Volume 1 is information on the disassembly and reassembly, lubrication, and principles of operation of the component units of the Teletypewriter Sets. Volume 2 includes adjustment information on all component units of 33 Teletypewriter Sets.

Each volume is made up of a group of appropriate, independent sections. They are separately identified by title and section number, and the pages of each section are numbered consecutively, independent of other sections. The identifying number of a section, a 9-digit number, appears on each page of the section, in the upper left corner of left-hand pages and the upper right corner of right-hand pages.

To locate specific information, refer to the table of contents. Find the name of the involved component in column one and the title of the section in column two. The correct 9-digit section will then be found in column three. The sections are arranged in the order shown in the table of contents. Turn to page one of the section indicated where the contents of that section will be found (except where a section is small and does not require a listing of contents).

The sections comprising this bulletin are now stocked separately and may be individually ordered if the entire bulletin is not required.

HP Computer Museum
www.hpmuseum.net

For research and education purposes only.

TABLE OF CONTENTS

FILING INSTRUCTIONS

1. The following filing instructions apply to changes sent to the field.
2. Asterisks (*) in the table of contents indicate changes.
3. When the issue of a section changes, replace the old issue with the attached new one.
4. In the case of addendums, turn to the affected section and follow the instructions on the first page of the attached addendum.
5. Replace the old table of contents with the new one.

<u>Equipment</u>	<u>Content</u>	<u>Section</u>	<u>Issue</u>
Teletypewriter Set	General Description and Operation	574-100-101TC	3*
Teletypewriter Set	Optional Features	574-100-104TC	1*
Teletypewriter Set	Circuit Description	574-100-103TC	1
Teletypewriter Set	Installation	574-100-201TC	6*
Teletypewriter Set	Removal and Replacement of Components	574-100-702TC	3*
Keyboard	General Description and Principles of Operation	574-121-100TC	4*
Keyboard	Lubrication	574-121-701TC	4*
Keyboard	Disassembly and Reassembly	574-121-702TC	4*
Typing Unit	General Description and Principles of Operation	574-122-100TC	3
Typing Unit	Lubrication	574-122-701TC	4*
Typing Unit	Disassembly and Reassembly	574-122-702TC	3
Call Control Unit	General Description and Operation	574-123-100TC	3*
UCC39 Call Control Unit	General Information	574-123-103TC	1
Tape Reader	General Description and Principles of Operation	574-124-100TC	4*
Tape Reader	Lubrication	574-124-701TC	3*
Tape Reader	Disassembly and Reassembly	574-124-702TC	2
Tape Punch	General Description and Principles of Operation	574-125-100TC	4*
Tape Punch	Lubrication	574-125-701TC	4*
Tape Punch	Disassembly and Reassembly	574-125-702TC	2
Cover	General Description	574-126-100TC	2
Cover	Lubrication	574-126-701TC	1

33 TELETYPEWRITER SETS
 GENERAL DESCRIPTION AND OPERATION

CONTENTS	PAGE
1. GENERAL	1
2. TELETYPEWRITER SETS	2
RECEIVE-ONLY (RO) TELETYPEWRITER SET	2
KEYBOARD SEND-RECEIVE (KSR) TELETYPEWRITER SET	2
AUTOMATIC SEND-RECEIVE (ASR) TELETYPEWRITER SET	2
CUSTOMER OPTIONS	3
3. COMPONENTS	3
A. Typing Unit	3
B. Call Control Unit	6
C. Keyboard	6
D. Tape Punch	7
E. Tape Reader	7
4. SET FEATURES	7
5. TYPICAL OPERATION AND APPLICATION	9
6. TECHNICAL DATA	10

1. GENERAL

1.01 This section provides the general description and operation for 33 Teletypewriter Sets. It is reissued to consolidate 33 Teletypewriter Set coverage and to delete coverage of variable features and accessories. Description of the features and accessories can now be found in Section 574-100-104TC. Since this is a general revision, marginal arrows used to indicate changes and additions have been omitted.

1.02 The 33 Teletypewriter Sets described in this section are electromechanical apparatus that provide terminal facilities for exchanging recorded communication via appropriate transmission facilities, including telegraph lines, telephone networks, and radio channels.

1.03 Terminals in the 33 line are available with either 50 or 60 Hz motors and can use either teletypewriter paper (friction feed) or accommodate multiple-copy business forms (sprocket feed). They operate at 10 characters per second (110 baud), feature four-row keyboards, and utilize ASCII (American National Standard Code for Information Interchange). The sets offer a choice of type wheel/keytop combinations and generate alphas, numerics, and many special control codes in even parity. They also provide answer-back on most configurations. Transmission mode may be half or full duplex. Current interface is standard with Electronic Industries Association (EIA) RS-232-C available as a modification kit.

1.04 Some of the equipment available for use with the 33 Terminal (refer to Section 574-100-104TC for a description of optional features) includes various paper and tape handling devices and the magnetic tape terminal which may be added for on-line data transmission and reception up to 2400 words per minute. Model 33 Sets, with the addition of 9100 Series TELETYPE® Station Controllers, can be used in selective calling systems.

1.05 References to left, right, up, down, front, rear, etc, consider the teletypewriter set as viewed by the teletypewriter operator.

1.06 This section covers the following 33 Teletypewriter Sets:

- (a) Receive-Only (RO) Teletypewriter Set
- (b) Keyboard Send-Receive (KSR) Teletypewriter Set
- (c) Automatic Send-Receive (ASR) Teletypewriter Set.

1.07 For schematic and actual wiring diagrams with circuit description, refer to the Wiring Diagram Package (WDP) shipped with the equipment.

2. TELETYPEWRITER SETS

RECEIVE-ONLY (RO) TELETYPEWRITER SET (Figures 1 and 4)

2.01 The RO set receives and prints messages on a paper copy. It consists of the following components:

- Typing unit
- Call control unit
- Cover
- Stand (if so equipped)

2.02 The RO set can only be used to receive and print messages from other connected sets. Sending is limited to the answer-back mechanism.

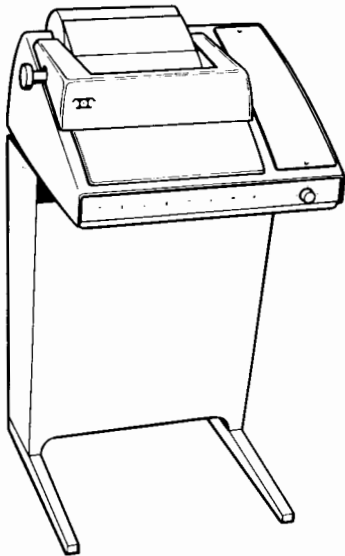

Figure 1 - Typical Model 33 Receive-Only (RO) Teletypewriter Set

KEYBOARD SEND-RECEIVE (KSR) TELETYPEWRITER SET (Figures 2 and 4)

2.03 The KSR set receives and prints messages on a paper copy. It can generate messages from its keyboard and answer-back mechanism. The KSR set consists of the following components:

- Keyboard
- Typing unit
- Call control unit
- Cover
- Stand (if so equipped)

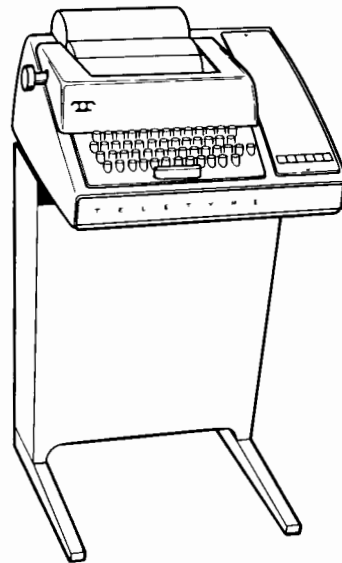

Figure 2 - Typical Model 33 Keyboard Send-Receive (KSR) Teletypewriter Set

2.04 The KSR set can be used in the following ways:

- (a) To generate and send messages from its keyboard
- (b) To receive and print messages from other connected sets and its own keyboard.

AUTOMATIC SEND-RECEIVE (ASR) TELETYPEWRITER SET (Figures 3 and 4)

2.05 The ASR set receives and records messages on paper tape and/or page copy. It can generate messages from its keyboard,

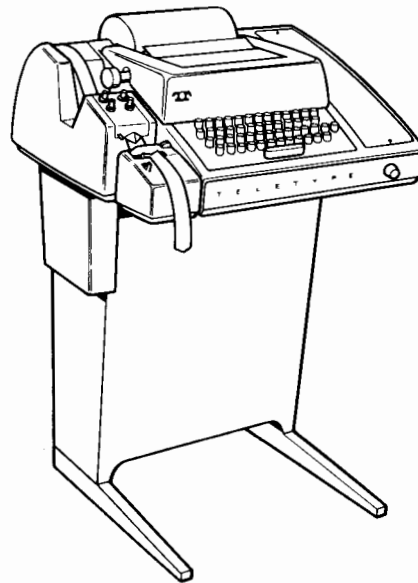

Figure 3 - Typical Model 33 Automatic Send-Receive (ASR) Teletypewriter Set

tape reader, and answer-back mechanism. The ASR set (Figure 5) consists of the following components:

- Keyboard
- Typing unit
- Call control
- Paper tape reader
- Paper tape punch
- Cover
- Stand (if so equipped)

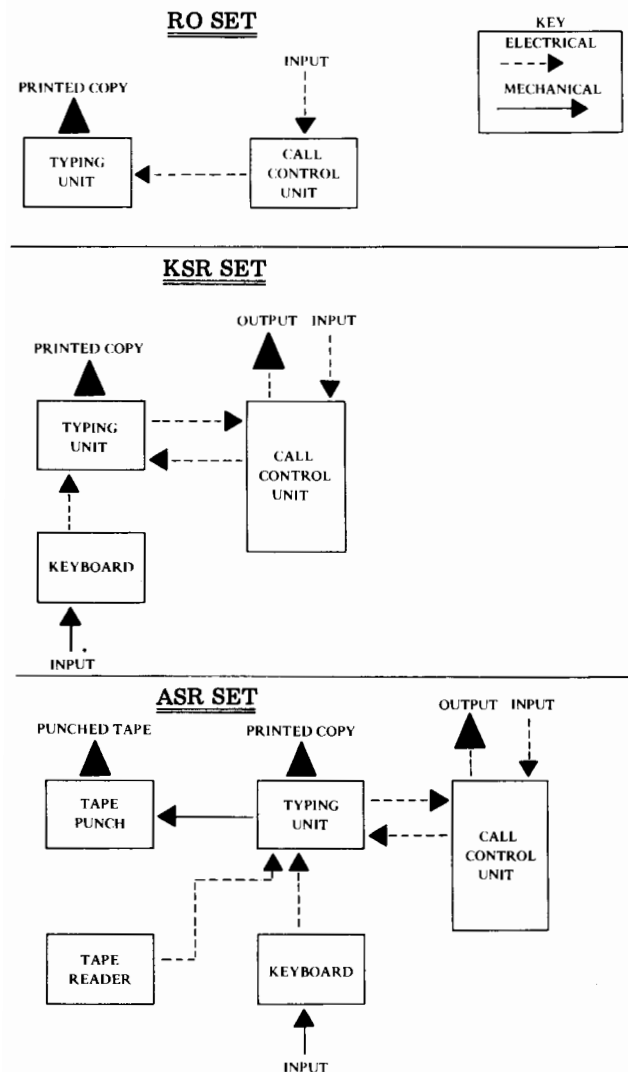

Figure 4 - Block Diagram of 33 Sets

2.06 The ASR set can be used in the following ways:

- (a) To send messages from the keyboard while making a printed page copy with or without punching tape

- (b) To receive messages from line and print them on page copy with or without punching tape
- (c) To prepare tape locally from keyboard for later sending while making a printed page copy
- (d) To send messages from tape while making a page copy with or without punching tape.

CUSTOMER OPTIONS

2.07 The following customer options are available:

- (a) Automatic/manual (AUTO/MAN) tape punch (customer activated)
- (b) Automatic carriage return and line feed (CR/LF) function (customer activated)
- (c) Choice of either automatic/manual (AUTO/MAN) or manual tape readers
- (d) Wiring options on the keyboard to retain even parity or to have the eighth bit always marking or spacing
- (e) Distributor trip mechanism for reader and answer-back magnet options.

3. COMPONENTS

33 Sets

3.01 In this section, only a brief outline of component operation will be presented. Individual components are described in detail each in a separate section. Refer to the following sections for a general description and principles of operation of the components:

Typing Unit	574-122-100TC
Call Control Unit	574-123-100TC
Keyboard	574-121-100TC
Tape Punch	574-125-100TC
Tape Reader	574-124-100TC

A. Typing Unit

3.02 The typing unit is the receiving component of the set. A signal coming into the typing unit is translated into a mechanical arrangement of codebars. The position of these codebars determines two things: the position of a type wheel upon which characters are embossed,

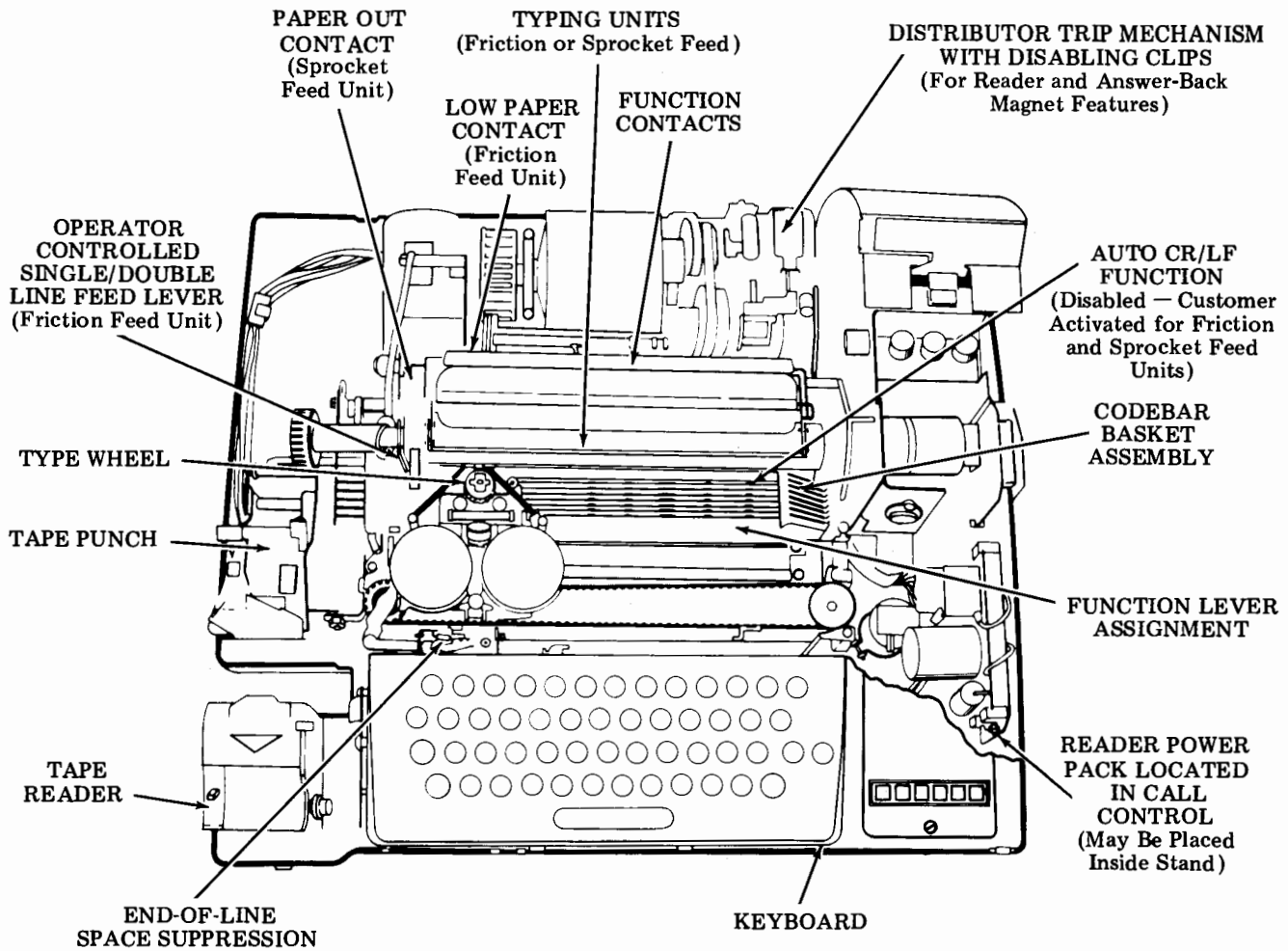

Figure 5 - Typical Model 33 Automatic Send-Receive (ASR) Teletypewriter Set With Cover Removed

and the selection of functions such as carriage return and line feed. A motor, by means of a main shaft, supplies all the motive force to effect the printing and perform the functions. The friction feed set may be considered the standard type of set. It handles 8-1/2 inch paper, and will accommodate 72 characters per line, 10 characters per inch. Vertically the friction feed set will print three or six lines per inch and will normally print one original and one copy.

3.03 A TP183498 "A" codebar, TP186783 extension clip for friction feed printers, and a TP186803 extension clip for sprocket feed printers provide the end-of-line (EOL) bell on the 71st character and the automatic carriage return (ACR) line feed on the 72nd character (Figure 6). Refer to appropriate related sections for detailed descriptions, installation and adjustments.

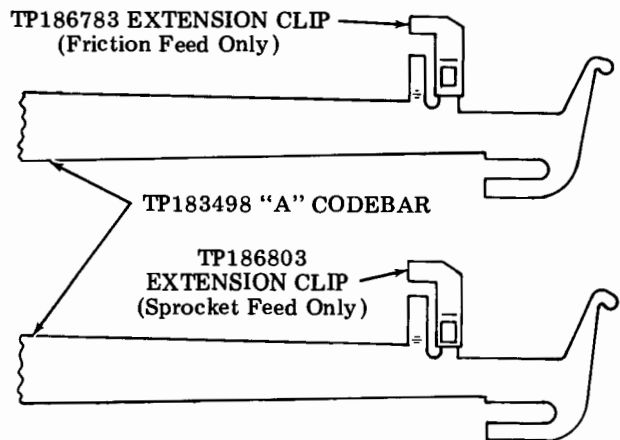

Figure 6 - Codebar With End-of-Line (EOL) Bell and Automatic Carriage Return (ACR) Line Feed Extension Clips

3.04 The TP186781 and TP186782 stop clips were designed to block the function levers of unwanted functions from sensing their printer codebars (Figure 7). The installation of the TP186781 and TP186782 stop clips is as follows:

(1) The TP186781 function lever stop clip is a short clip and is used in the related function box numbered slot. That is, the clip is placed over the slot of the codebar basket tie bar which is in direct line with the numbered function box slot. The TP186782 function lever stop clip is a long clip and is placed over the related letter slots of the codebar basket (Figure 7).

(2) To enable automatic carriage return-line feed in a friction feed type unit, a stop clip is not provided over slot "A". When the function is to be disabled, the stop clip is placed over slot "A" of the codebar basket.

(3) To inactivate the automatic carriage return-line feed functions in a sprocket feed typing unit, a TP186872 stop clip is placed over the related slot "A" and also slot "L" of the codebar basket tie bar. The function lever in slot "A" performs the automatic carriage return function and the function lever in slot "L" performs the automatic line feed function.

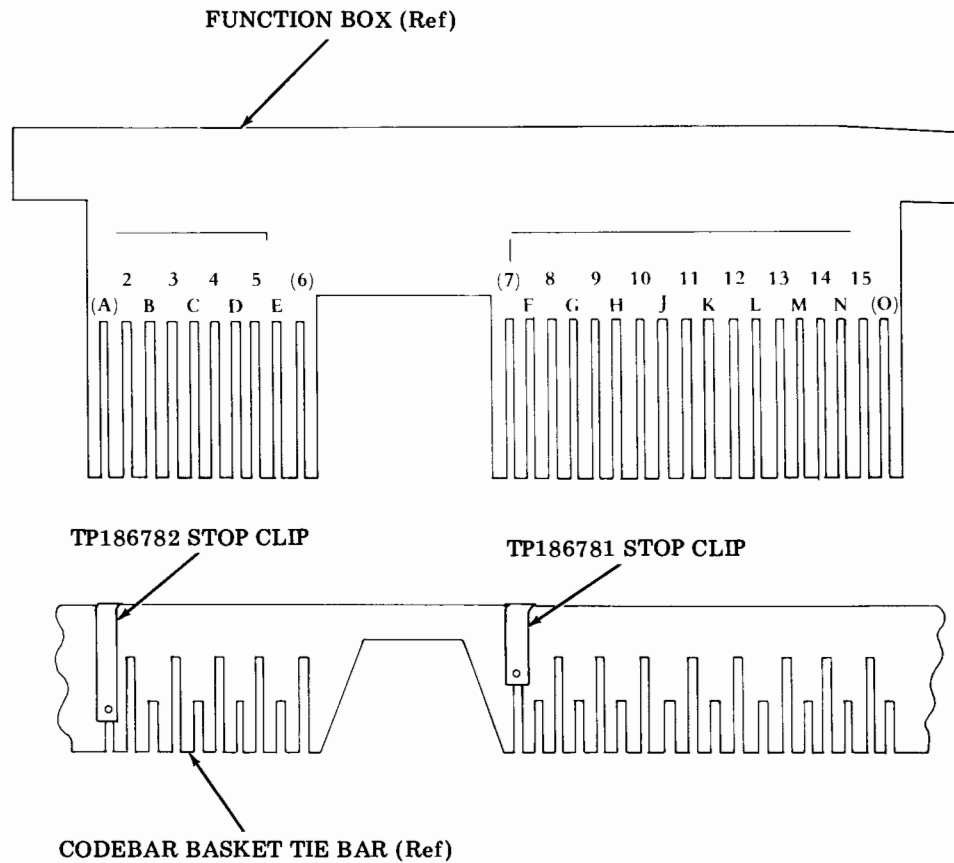

Note: Characters and numbers in () are not moulded in function box casting.

INSTALLATION OF FUNCTION LEVER STOP CLIPS

Figure 7 - Stop Clips to Block Unwanted Functions

- (4) To activate the two functions for ACR-LF in sprocket feed units, the stop clips are removed.

Note: The TP186781 or TP186782 stop clips cannot be used on typing units incorporating the print-nonprint feature using the TP183565, TP183566, and TP183567 blocking bars in their codebar baskets.

- (5) To enable the margin bell and end-of-line bell, a function lever stop clip is not provided in slot "F" of the codebar basket.
- (6) To disable the margin bell and end-of-line bell, a function lever stop clip is placed over slot "F" of the codebar basket.
- (7) If margin bell is required and no automatic carriage return-line feed and end-of-line bell is required, the TP186783 "A" codebar extension for friction feed units or TP186803 extension clip for sprocket feed units is removed. When end-of-line bell is a requirement, the margin bell is also a requirement. Both functions are operated from the same function lever.

Note: The stop clips may be used to block other function levers located in the right side of the codebar basket. The stop clips, if removed, should not be reused. A new clip should be installed.

3.05 The TP186873 stop plate is for ASR sets without tape reader trip magnet option, and for KSR and ASR sets without answer-back trip magnet option (Figure 8). Following are the installation procedures for the stop plate:

- (1) The stop plate prevents the TP183098 tape reader clutch trip lever or the TP180843 answer-back trip lever from operating when either the reader trip or answer-back magnets and associated armature parts are absent.
- (2) The stop plate is present only when there is no magnet with associated parts and may be replaced by one of three different voltage type magnets for reader or answer-back operation. The voltages of the magnets are 24 volts dc, 48 volts ac or dc, or 115 volts ac.

- (3) The TP186873 stop plate is installed in either the reader trip lever magnet position or answer-back position or both (Figure 8).

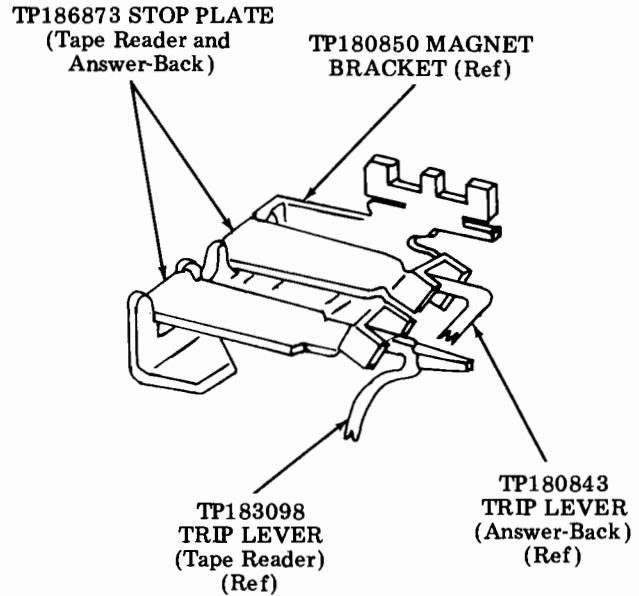

Figure 8 - Stop Plate for Tape Reader and Answer-Back Trip Levers

B. Call Control Unit

3.06 The call control unit serves as a bridge to electrically join the set to the communication networks. In some applications the call control unit serves to initiate, accept, control, and complete the incoming calls. A power supply, local-remote control circuits, and a selector magnet driver circuit are some of its basic elements.

C. Keyboard

3.07 The keyboard is the sending component of the set. Each of its keys control an arrangement of levers which, in turn, position electrical contacts to represent ASCII characters with or without even parity. The keyboard output is a parallel output to the distributor of the typing unit. In half-duplex, the distributor senses the keyboard output and sends it in a serial form to the selector magnet driver. From the selector magnet driver it then goes to the typing unit selector. In full duplex the output is sent by the distributor to the distant station.

D. Tape Punch

3.08 The input to the tape punch is strictly mechanical. The tape punch is a slave of the typing unit; extensions on the typing unit codebars position themselves in the tape punch to set up a similar coded arrangement of punch pins. With drive motion from the typing unit main shaft, the tape punch drives the punch pins to perforate holes in paper tape.

3.09 Some of the tape punches incorporate the customer activated option of automatic operation. The automatic option is activated by removal of the two factory installed disabling clips. The manual controls are not disabled and may still be used for operation or to override the automatic functions if desired. The automatic functions may be disabled by reinstalling the clips. Refer to Section 574-125-100TC for more detailed description and to Section 574-100-201TC for installation instructions.

E. Tape Reader

3.10 Sensing pins in the tape reader are driven upward for every cycle. Where holes are present in the tape, the sensing pins close a set of contacts. Where no holes are present in the tape, the sensing pins are blocked and make no contact. These current, no-current conditions are duplicated at the distributor in parallel form. The distributor then sends the code serially to the selector magnet driver in the call control unit. From the call control unit the pulses go to the typing unit to print the character.

3.11 In some sets, the tape reader power pack is located in the call control unit and enclosed in the right side of the set cover. Optionally, the power pack may be mounted in the stand.

3.12 There is a choice of either manual or an automatic/manual tape reader in the 33 line (Figure 5). Refer to Section 574-124-100TC for the detailed description of the readers.

Note: When preparing tape, all functions (except information separators), such as form-out, carriage return, line feed, etc, must be followed by two fill characters such as delete. These fill characters are required to provide time for the desired function to occur.

4. SET FEATURES

4.01 Functions — Functions refer to non-printing operations performed by the set which are supplementary to its purpose of printing characters. All sets are equipped for the following functions:

CARRIAGE RETURN — Upon command to carriage return, the movable printing mechanism returns to the left margin.

LINE FEED — Advances the paper or sprocket form one or two lines.

SPACE — Every character printed is spaced a certain distance from the previous one automatically. However, the set can accept a separate command to space in which case it will move the printing mechanism one character space to the right.

SPACE SUPPRESSION — In some instances, such as when commands to carriage return or line feed are given, the set spacing mechanism is suppressed and no spacing occurs. Spacing is suppressed at end-of-line and on all functions except the space function.

PRINT SUPPRESSION — The printing mechanism is suppressed so that no printing occurs when the set receives commands to perform any of the functions.

NULL — The null function serves to suppress printing.

4.02 Even Parity Keyboard — The 33 Sets use seven intelligence pulses to accommodate the code combinations of ASCII. The remaining eighth pulse may be used as an error detection device. In sets so equipped, the even parity keyboard adds an eighth marking pulse whenever the number of marking pulses in an ASCII code combination is odd. If the number of marking pulses in a code combination is even, the eighth pulse is transmitted as a spacing pulse. This means that every code combination transmitted by the even parity keyboard has an even number of marking pulses.

Note: Keyboards not equipped with the even parity feature always transmit the eighth pulse as a marking pulse. The even parity feature may be disabled by the customer to present an always marking or always spacing condition in the 8th level.

SECTION 574-100-101TC

4.03 **Numeric Keyboard** — As the name implies, this optional feature consists of a keyboard with a numeric arrangement. This restricts the set for specialized applications where the exchange of data is mainly of a numeric nature. The keyboard can, if necessary, accommodate a limited number of alpha characters and nonprinting functions such as carriage return, line feed, etc.

4.04 **Answer-Back** — In sets equipped with this feature, a mechanism coded with a predetermined sequence of maximum twenty characters is used for identification purposes. The mechanism may be actuated locally or remotely.

4.05 **Automatic Carriage Return-Line Feed** — In sets so equipped, as printing approaches the end of the line, the printing mechanism is returned to the left margin and the paper is advanced one line vertically.

4.06 **Sprocket-Feed** — Sprocket feed sets print characters on a sprocket fed form. The forms are 8-1/2 inches wide and feed out in half- or full-page segments (5-1/2 and 11 inches). Additional options for form lengths are available. A total of 72 characters may be printed in a line on the form with 10 characters per inch. The set will accommodate three or six lines of printed characters per inch. Varying with the weight of the carbon, the set will normally print one original and two copies. When the set has used all the forms available, an alarm will disable the set from accepting incoming calls (with data set only).

4.07 **Form-Out (Sprocket Feed Only)** — In sets so equipped, the form-out mechanism advances the forms to a predetermined length upon command. The mechanism is adjustable to various fixed form lengths.

4.08 **Paper-Out Alarm (Sprocket Feed Only)** — A set equipped with this feature and a data set will activate an alarm when the supply of forms is exhausted. The set will also refuse to accept any other incoming calls.

4.09 **Low Paper Alarm (Friction Feed Only)** — When the amount of paper on the roll reaches a certain amount, a switch activates an alarm (customer provided) which indicates to the operator that the paper supply is low.

4.10 **Automatic Punch Controls** — This feature allows a number of operating modes for turning the tape punch ON and OFF. The tape punch can be turned ON and OFF manually or automatically.

4.11 **End-of-Line Bell** — Sets with this feature alert the operator that the printing mechanism is approaching the end of the line at the right margin.

4.12 **Line Break** — This feature places the set, so equipped, in an open line condition. A BREAK key on the keyboard effects the operation.

4.13 **Repeat** — Sets equipped with this feature can print a character or perform a nonprinting function continuously when the REPEAT key is depressed on the keyboard together with another key.

4.14 **Automatic Reader Control** — An ASR station equipped with automatic reader control may have its reader activated from a distant station upon receipt of DC1 (formerly X-ON) and off on DC3 (formerly X-OFF).

4.15 **Copyholder** — The feature consists of a metal frame equipped with a line indicator. The frame mounts on the back of the set, facing the operator. Messages to be transmitted may be placed on the copyholder for convenience during transmission.

4.16 **End-of-Transmission (EOT)** — When equipped with this feature (data set or station controller required), the sending set can indicate to the receiving set that the entire message has been sent out and transmission is terminated. The keyboard has an EOT key which will activate the mechanism.

4.17 **Accessories** — A number of accessories are available with the set, including the following:

(a) A sheet metal stand which supports the subbase and components at a convenient operating level. It consists of feet, equipped with leveling screws or roller casters (optional modification kit), and an enclosure to house auxiliary apparatus, such as a data set and the tape reader power pack.

(b) Call control facilities, including buttons, indicator lamps, speaker, ringer, buzzer, and rotary, TOUCH-TONE* or card dialers.

*Registered Trademark of AT&TCo.

5. TYPICAL OPERATION AND APPLICATION

Telephone or Telegraph Network System Operation

5.01 The following is a brief description of how 33 Teletypewriter Sets, equipped with call control and answer-back features, may be used in a typical telephone or telegraph network communication system (Figure 9). When a call is to be made, an operator uses the controls on the teletypewriter set to gain access to the system switching and transmission facilities, which may be dial telephone or telegraph networks. The operator then dials the number of the called station.

5.02 The switching center selects the proper station and signals the receiving station — indicated by visual and/or audible indicators. Using the controls on the teletypewriter set, the operator at the called station completes the connection and conditions the equipment so that

communication can proceed in either direction. This is indicated visually and/or audibly at the calling station.

Note: Variations of call control features provide unattended reception of calls.

5.03 Ordinarily, the stations then identify themselves by the answer-back feature. The operator at the calling station can then type the message on the keyboard, or if it is an ASR set, can send it by perforated tape. In either case the teletypewriter set at the calling station translates the message to dc sequential start-stop signals which are applied to the transmission facilities. The teletypewriter sets at both the sending and receiving stations receive the signals and translate them to mechanical motions which print the message on continuous page copy or forms, and/or in the case of the ASR, perforate it in tape. If telephone networks are used, the dc start-stop signals are converted to tone frequencies for transmission and reconverted to dc start-stop signals for reception.

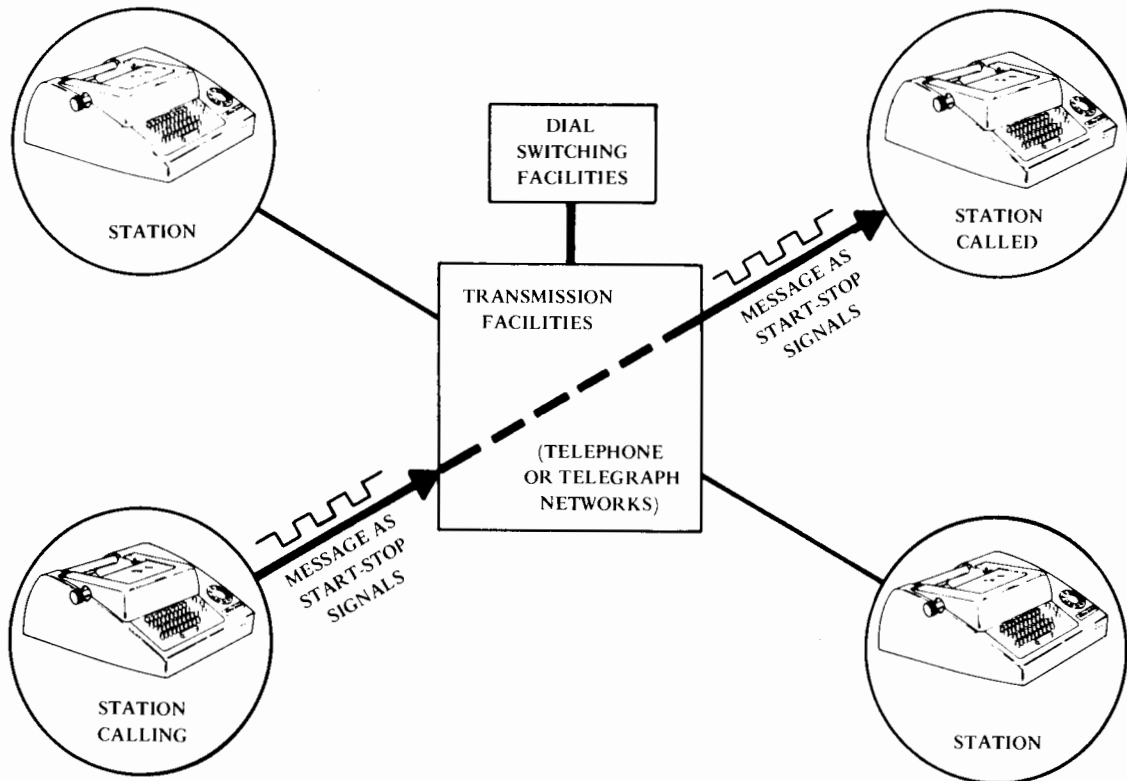

Figure 9 - Typical Applications

5.04 Finally, the operator at either station can terminate the call and return the set to its idle condition by operating the OFF control. There are a variety of OFF controls, including the EOT key, in conjunction with a data set, on the keyboard, a control knob, or a pushbutton on the call control unit. A set may be equipped with one or two of these controls. In the case of an RO set, only one OFF control is necessary. In the case of a KSR and ASR set, the EOT control on the keyboard, in conjunction with a data set, or the pushbutton on the call control unit may be used.

6. TECHNICAL DATA

CAUTION: THIS EQUIPMENT IS INTENDED TO BE OPERATED IN A ROOM ENVIRONMENT WITHIN THE TEMPERATURE RANGE OF 40°F TO 110°F. SERIOUS DAMAGE TO IT COULD RESULT IF THIS RANGE IS EXCEEDED. IN THIS CONNECTION, PARTICULAR CAUTION SHOULD BE EXERCISED IN USING ACOUSTICAL OR OTHER ENCLOSURES.

6.01 Speed 100 words per minute
600 operations per minute

6.02 Transmission Code — 8 Level Start-Stop Signals With 11 Unit Transmission Pattern:

Start pulse 1 unit of time
Intelligence pulses 8 units of time
Stop pulses 2 units of time
11-unit code

6.03 Dimensions and Weights (Approximate):

(a) RO Set

Width 18-5/8 inches
Depth 18-1/2 inches
Height 8-3/8 inches
Weight 39 pounds

(b) KSR Set

Width 18-5/8 inches
Depth 18-1/2 inches
Height 8-3/8 inches
Weight 40 pounds

(c) ASR Set

Width 22 inches
Depth 18-1/2 inches
Height 8-3/8 inches
Weight 44 pounds

(d) Stand

Width 17-3/4 inches
Height 24-1/2 inches
Depth
(at top of enclosure) . . . 6-1/2 inches
Length of Feet 17-3/4 inches
Weight 12 pounds

6.04 Electrical Requirements:

Power Requirements . . 115 volts ac $\pm 10\%$
either 60 or 50 hertz
 ± 0.45 hertz, single phase

Signal Line Current 0.020 or 0.060
ampere

Nominal Input
to Selector 0.500 ampere at
20 volts dc

Operating Margins — All Signal Contacts and Distributor:

Long Telegraph Loops 0.015 to
0.070 ampere at 48 to
240 volts dc inductive

Short Telegraph Loops 0.058 to
0.072 ampere at 16 to
22 volts dc resistive

6.05 Environmental Tolerances:

(a) The teletypewriter will operate under worst-case conditions within a temperature range of 40°F and 110°F; a relative humidity of 2 percent to 95 percent with the room air velocity between 5 and 55 feet per minute. Altitudes may vary from sea level to 10,000 feet.

(b) Storage temperatures may range from minus (-) 40°F to 150°F with altitudes up to 50,000 feet.

MODEL 33 ASR, KSR, AND RO

OPTIONAL FEATURES

CONTENTS	PAGE	CONTENTS	PAGE
1. GENERAL	2	I. 185983 Modification Kit — To Equip Model 33 Friction Feed Typing Unit With Carriage Return on Line Feed	9
2. OPTIONAL FEATURES	2	J. 186136 Modification Kit — To Operate Model 33 Private Line Sets With DATA-PHONE* and Private Line Data Sets	9
A. 180801 Universal Function Lever	2	K. 186185 Modification Kit — To Convert Model 33 Sprocket Feed Typing Unit Form-Feed Rate From Six Lines Per Main Shaft Rotation to Three Lines	10
B. 182056 Modification Kit — Provides Model 33 Typing Units With 12 Character-Per-Inch Spacing	2	L. 186226 Modification Kit — To Provide Model 33 Sets With Mobility	12
C. 183859 Modification Kit — Equips Model 33 Cabinet With a Paper Supply Bin and Accumulating Shelf	3	M. 186241 Modification Kit — To Convert Model 33 Private Line ASR Sets to Automatic Reader Control	13
D. 183877 Through 183883 Modi- fication Kits — To Equip Sprocket Feed Typing Unit With Form Out for Various Lengths of Forms	4	N. 186776 Modification Kit — To Provide a Handle for Model 33 Typing Unit	13
E. 183986 A Through D Modi- fication Kit — To Provide Print-Nonprint on ASR Typing Sets	4	O. 187125 Modification Kit — To Provide 48 V AC 24 V DC Magnet Controlled Answer- Back Trip Mechanism for Model 33 Typing Unit	14
F. 184157 Modification Kit — To Equip Friction Feed Typing Unit to Provide Automatic Line Feed When Carriage Return Key is Depressed	5	P. 194822 Directory Holder for Model 33 KSR and ASR Cabinets	15
G. 185703 Modification Kit — To Add Punch Interlock to an ASR Set Equipped With Automatic Punch and the 183986 Print-Nonprint Modi- fication Kit	6	Q. 198420 Modification Kit — To Connect TELETYPE® Terminal Apparatus to 103 Series Data Sets, or Equivalent	15
H. 185705 Modification Kit — To Provide a Tape Guide for Folded Tape on ASR Sets	8		

*Registered Service Mark of AT&TCo.

CONTENTS	PAGE
R. 199931 Modification Kit — To Provide Model 33 ASR Sets With An Intermediate Tape Storage Bin	16
S. 333521 AC Series Motor Assembly for Model 33 Sets	17
T. 343691EW Modification Kit — To Provide a Shelf for Attendant Set on Model 33 KSR or ASR Set	18

1. GENERAL

1.01 This section provides information on optional features for the Model 33 ASR, KSR, and RO Sets. The information includes a description of the option and necessary references to adjustments, lubrication, and disassembly and reassembly. Parts and installation are not included but reference is made to the appropriate component section and installation specification.

1.02 Copies of the sections and specifications referred to in this section may be obtained from Teletype Corporation. Every modification kit comes from the factory with the necessary installation specification.

2. OPTIONAL FEATURES

A. 180801 Universal Function Lever

2.01 The 180801 universal function lever has no marking or spacing tines removed. This allows the customer to optionally remove tines and code the function lever to respond to "nonstandard" code combinations, or replace damaged function levers. Necessary contact assemblies must be ordered separately. See the function box mechanism in Section 574-122-800TC.

2.02 The 180801 universal function lever is to be installed only in the numbered slots of the function casting, such as 4, 5, 6, etc. Do not install the universal function lever in the lettered slots of the function casting, such as B, C, D, E, F, etc.

2.03 The tines on the universal function lever are easily broken off with long-nose pliers.

2.04 The tines of the 180801 function lever are numbered from right to left in (Figure 1) as follows: PS, 1, 2, 3, 4, 5, 7, 6, 8.

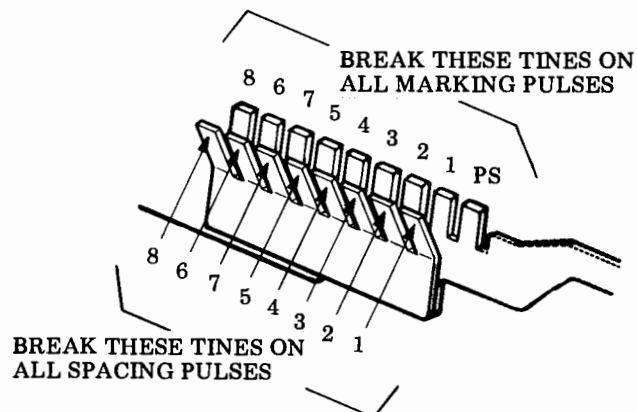

Figure 1 - 180801 Universal Function Lever

2.05 There are two rows of tines on the universal function lever. The straight row of tines corresponds to the marking pulses of a given code combination; the slanted row of tines corresponds to the spacing pulses of a given code combination.

2.06 Break both the marking and spacing no. 8 tines on units without parity. On units with parity do not break off the marking and spacing no. 8 tines. Break the PS (Print Suppression) tines when printing is desired.

2.07 Instructions for coding the universal function lever are in Section 574-122-700TC. Specification 50370S has both the coding and installation into unit information.

B. 182056 Modification Kit — Provides Model 33 Typing Units With 12 Characters-Per-Inch Spacing

2.08 The 182056 modification kit converts the Model 33 typing unit from the standard 10 characters to 12 characters-per-inch horizontal spacing (Figure 2).

2.09 Typing units modified with the 182056 modification kit offer a choice of 83, 86, or 89 characters per line.

2.10 Parts ordering information is in Section 574-122-800TC. Installation, lubrication, and adjusting procedures are in Specification 50448S. Section 574-122-700TC is required for standard adjustments.

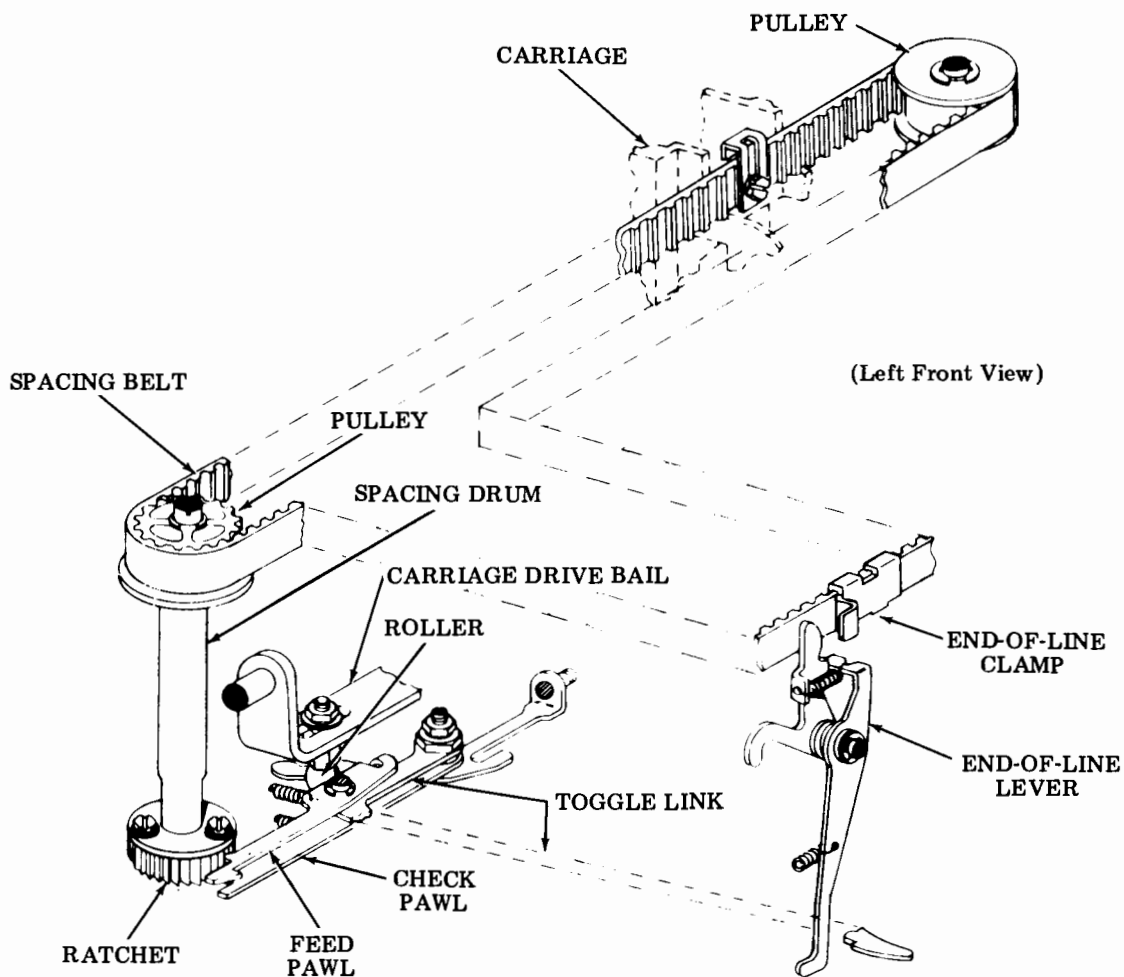

Figure 2 - 182056 Modification Kit for 12 Character-Per-Inch Spacing

C. 183859 Modification Kit — Equips Model 33 Cabinet With a Paper Supply Bin and Accumulation Shelf

2.11 The 183859 modification kit will accumulate forms 8-1/2 inches wide varying in length from 6 to 12 inches. Forms are stored in the bin. They feed from inside the bin, under the shelf, under the plate, and under the platen mechanism. (See Figure 3.) Printed forms are accumulated on the 183857 shelf.

2.12 The vertical loading capacity of the bin is approximately 14 inches. The width of the bin is 10 inches.

2.13 In order to accommodate the various lengths of forms, the 184159 bracket may be positioned at various points on the 183857 shelf (Figure 3). Operator assistance may be required so the forms accumulate properly.

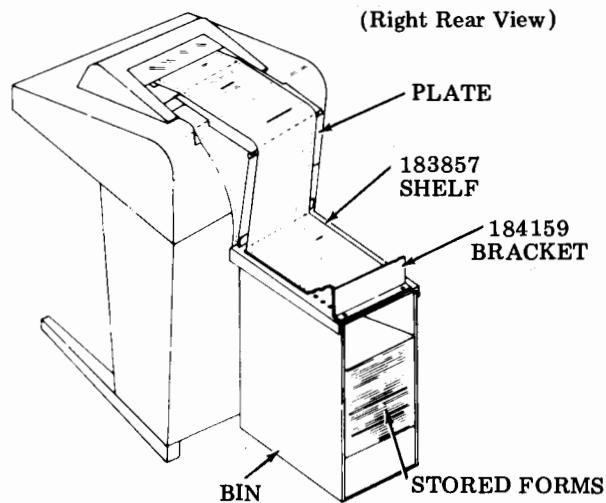

Figure 3 - 183859 Modification Kit to Provide Model 33 Cabinet With a Paper Supply Bin and Accumulation Shelf

SECTION 574-100-104TC

Improperly released forms, or forms that have been kept in the platen mechanism for some time will not position themselves neatly on the shelf.

2.14 The bin and accumulating shelf are positioned at the rear of the set, as close as possible to the rear panel.

2.15 Specification 50433S has the installation and adjusting information. Parts information is in Section 574-126-800TC.

D. 183877 Through 183883 Modification Kit — To Equip Sprocket Feed Typing Unit With Form Out for Various Lengths of Forms

2.16 Various form lengths can be accommodated on the sprocket feed typing units by changing the cam lobes, the spur gear, and the gear w/gear on the form-out mechanism (Figure 4). In addition to the cam lobes and gears, the 183877 through 183883 kits include two washers and one screw.

2.17 The modification kits and the form lengths they will handle are shown in the following chart. The chart also shows how many cam lobes are included in each kit with the resulting length of form out when these cam lobes are installed.

Modification Kit	No. of Cam Lobes Used		
	1	2	3
	Form Length (In Inches)		
183877	11	5-1/2	3-2/3
183878	9	4-1/2	3
183879	7	3-1/2	2-1/3
183880	8	4	2-2/3
183881	8-1/2	Not Used	2-5/6
183882	10	5	3-1/3
183883	6	Not Used	Not Used

2.18 Parts ordering information for the kits is in Section 574-122-800TC.

2.19 Installation, adjusting, and lubrication procedures are in Specification 50410S. For related adjustments, refer to Section 574-122-700TC.

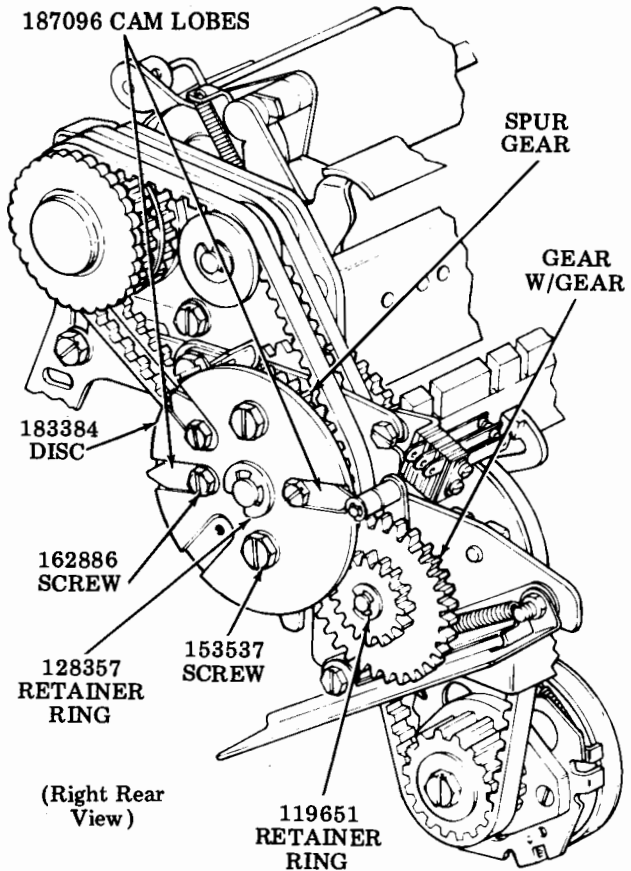

Figure 4 - 183877 Through 183883 Modification Kits for Various Lengths of Form Out

E. 183986 A Through D Modification Kit — To Provide Print-Nonprint on ASR Typing Sets

2.20 The 183986 print-nonprint modification kit cannot be installed if the set is equipped with the 182290, 182291, and 183128 modification kits. These kits provide Automatic Reader Control, Originate Automatic Transmitter Start (OATS) and Remote Transmitter Call In (RTCI).

2.21 The 183986 print-nonprint modification kit may be installed on any ASR catalog set. Part of the installation procedures for these sets will include some modification of the call control unit panels to accommodate the toggle switch associated with the kit.

2.22 If the kit is to be installed on sets which have a dial in the call control unit, a specific kit must be ordered. The various print-nonprint kits are:

- 183986A — Call control units with rotary dial
- 183986B — Call control units with TOUCH-TONE* dial
- 183986C — Call control units with TOUCH-TONE and card dial
- 183986D — Call control units with rotary and card dial

2.23 The print-nonprint modification allows the set to send or receive data without producing page copy. With the print-nonprint mechanism turned on, data may be transmitted from the keyboard or the reader without page copy. Data may be received and punched in tape without page copy. In the local mode, punched tape may be prepared without page copy.

2.24 The print-nonprint modification consists basically of a solenoid which operates a nonprint codebar (Figure 5). A toggle switch and an indicator lamp activate the mechanism. When turned on, the solenoid energizes moving the nonprint codebar to the right. In this position, the nonprint codebar blocks all the function levers from rising during the function cycle except the print suppression function lever. The print suppression function lever rises every cycle to suppress printing.

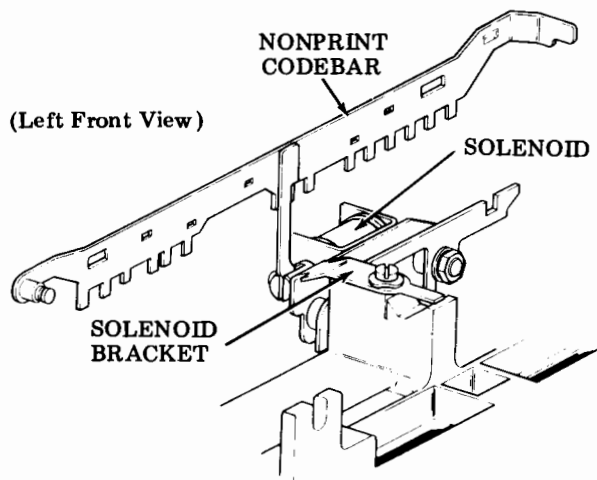

Figure 5 - 183986 A Through D Solenoid Operated Print-Nonprint Kits

2.25 Operation of the 183986 modification kit affects operation of the optional 185703 interlock mechanism. The 185703 interlock mechanism locks the automatic punch in the "on" mode and prevents it from being turned off

electrically. Once turned on, the punch must be turned off manually. Further details on the 185703 punch interlock option are included in this section. (See 2G.)

2.26 The 185703 punch interlock utilizes the position of the print-nonprint codebar to lock the punch in the "on" mode. Thus, the punch interlock operates only when the printer is in the nonprint mode. In the print mode (ie, print-nonprint mechanism not operating) the punch interlock does not operate.

2.27 Installation, adjusting, and lubrication procedures and parts ordering information are in Specification 50460S.

F. 184157 Modification Kit — To Equip Friction Feed Typing Unit to Provide Automatic Line Feed When Carriage Return Key is Depressed

2.28 The 184157 modification kit is applicable only to friction feed typing units. The printer will automatically line feed when the carriage return key is depressed. Note that line feeding will vary depending upon the end-of-line sequence used. If the end-of-line sequence is carriage return/line feed, the set will double line feed because of the line feed function associated with the carriage return. If the end-of-line sequence is carriage return, carriage return/line feed, the set will triple line feed.

2.29 Operation of the line feed mechanism relies upon the operation of the carriage return function lever. The blocking lever included in the kit is carried upward to engage the line feed drive link when the carriage return function lever rises upward during the first part of the cycle (Figure 6). During the middle portion of the cycle, both the carriage return function pawl and the line feed drive link are driven downward to effect carriage return and line feed.

2.30 Parts identification for this kit is included in Section 574-122-800TC.

2.31 Two adjustments are necessary with the 184157 modification: Line Feed Drive Arm Clearance — F (PLA-5) and Line Feed Upstop Bracket Position — F (PLA-6). For these and related adjustments, see 574-122-700TC.

2.32 If it becomes necessary to disassemble the kit, reverse the installation procedures given in Specification 50413S. The kit should be lubricated per Section 574-122-701TC.

*Registered Service Mark of AT&TCo.

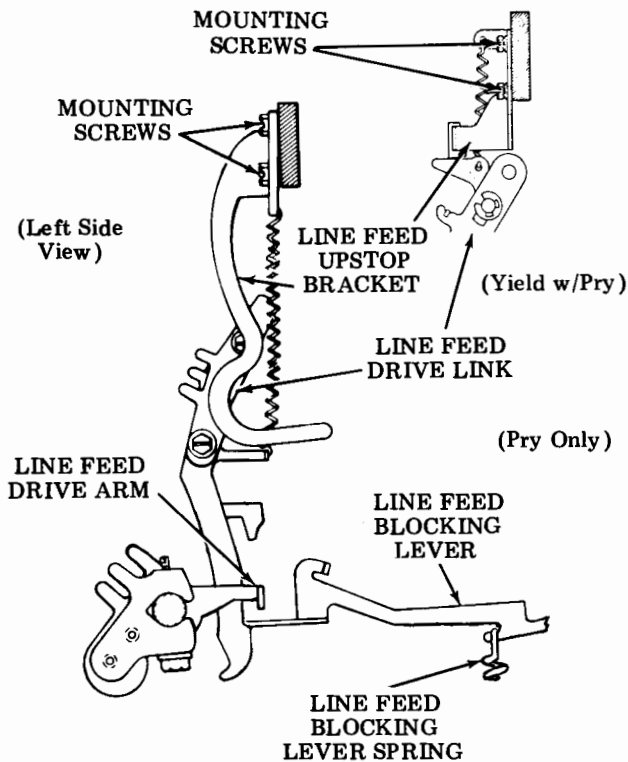

Figure 6 - 184157 Kit for Automatic Line Feed or Carriage Return

G. 185703 Modification Kit — To Add Punch Interlock to an ASR Set Equipped With Automatic Punch and the 183986 Print-Nonprint Modification Kit

2.33 The function of the 185703 kit is to lock the punch in the "on" mode and prevent it from being automatically turned off. This modification requires that the set is equipped with an automatic punch and the 183986 print-nonprint modification. The punch interlock feature is particularly useful in transmission involving foreign or computer data. When receiving such data, the punch could be prematurely turned off by a code combination resembling the ASCII (American National Standard Code for Information Interchange) DC4 code. (See Figure 7.)

2.34 There are no operator controls associated with this kit. The punch interlock operates in conjunction with the print-nonprint kit.

2.35 Operation of the interlock mechanism is briefly as follows: When the print-nonprint mechanism is turned on, the nonprint

codebar is pulled to the right. An extension on the nonprint codebar moves a bellcrank upward, which in turn pivots the latch bail counterclockwise. The counterclockwise motion of the latch bail releases the on-off bail and prevents it from latching up, thus keeping the punch in the "on" mode.

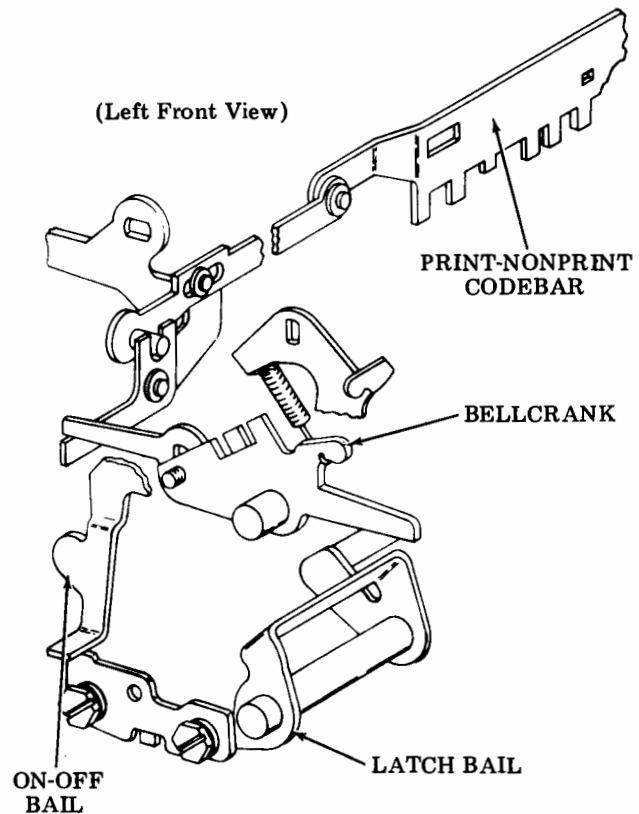

Figure 7 - 185703 Punch Interlock Mechanism

2.36 If the punch is off when the nonprint mechanism is activated, the latch bail unlatches the on-off bail and prevents it from being relatched either by the manual OFF pushbutton or automatically.

2.37 If the punch is on when the nonprint mechanism is activated, the latch bail is already unlatched and is prevented from relatching. The punch may be momentarily turned off by depressing the OFF pushbutton. The punch will turn on again when the pushbutton is released.

2.38 When the nonprint mechanism is turned off, the punch remains on until turned off either by depression of the OFF pushbutton or automatically.

2.39 Adjustments and spring tension peculiar to the 185703 modification kit are shown in Figures 8 and 9.

2.40 Lubricate all sliding surfaces, pivot points, and spring ends with a drop of KS7470 oil.

LEVER AND LATCH BAIL GAP

To Check

Typing unit in stop condition.
Print-nonprint solenoid energized.

Requirement

Min 0.015 inch -- Max 0.030 inch
between on-off bail and latch bail.

To Adjust

Remove interlock spring.
Loosen screw.
Position lever.
Tighten screw and reinstall spring.

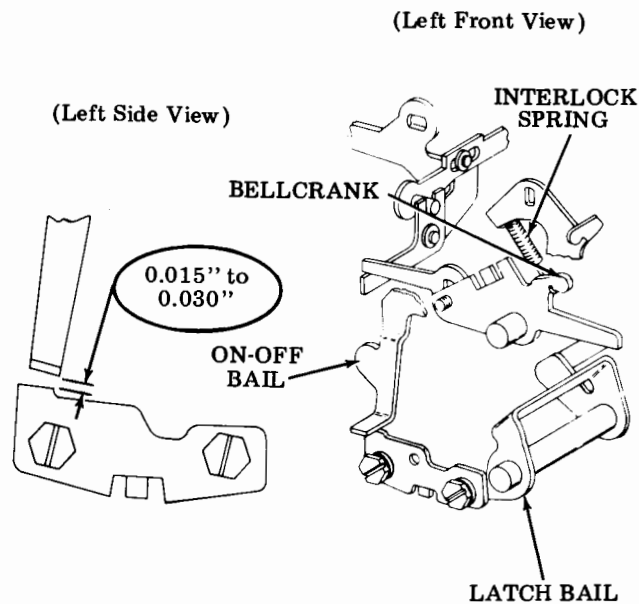

Figure 8 - Lever and Latch Bail Gap Adjustment (185703 Modification Kit)

2.41 Installation instructions for the kit are in Specification 50473S. Should it become necessary to remove the kit, reverse the installation procedure in Specification 50473S packed with the kit.

PUNCH INTERLOCK SPRING

To Check

Energize the print-nonprint solenoid.

Requirement

Min 4 oz -- Max 6 oz
to pull spring to installed length.

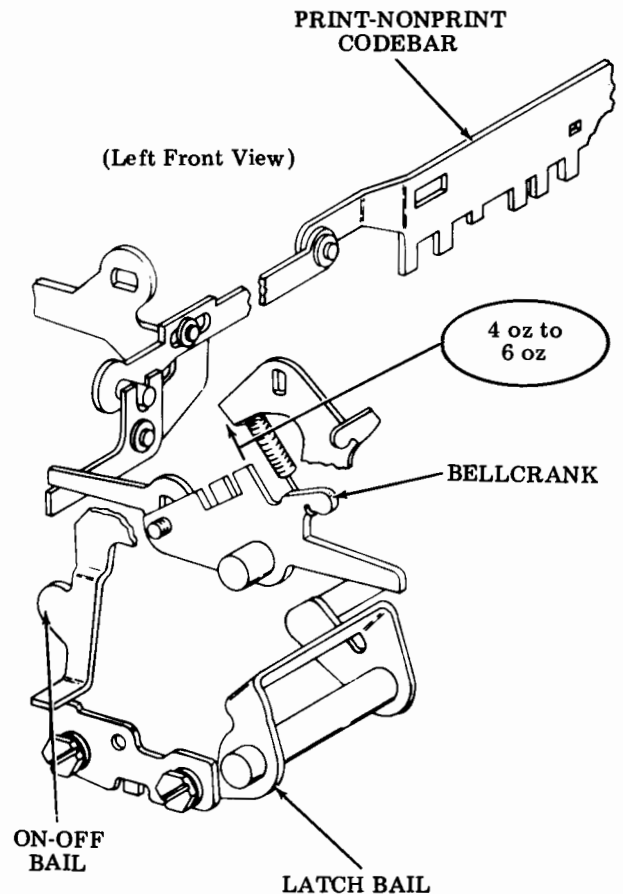

Figure 9 - Punch Interlock Spring (185703 Modification Kit)

H. 185705 Modification Kit — To Provide a Tape Guide for Folded Tape on ASR Sets

2.42 The 185705 modification kit provides a tape guide when using folded tape on the punch of a Model 33 ASR Set. This kit prevents tape from buckling upward or downward when using folded tape. The customer must provide external tape handling facilities.

2.43 Adjustment and lubrication procedures are in Figure 10. Parts ordering information is in Section 574-125-800TC.

2.44 Installation instructions are in Specification 50438S. Reverse the instructions in the specification for removal of the kit.

TAPE DEPRESSOR GAP

To Check

Loosen 151152 screw. Press 185706 bracket down so it rests on top surface of punch block casting. Tighten 151152 screw. Place a piece of tape through punch, as shown. Apply light finger pressure downward to the tape depressor.

To Adjust

Pivot the tab on the side of tape depressor up or down, as required.

Note: After doing this adjustment check the TEN CHARACTERS PER INCH adjustment (see Section 574-125-700TC).

Requirement

Min some --- Max 0.015 inch between tab of tape depressor and underside of chad chute.

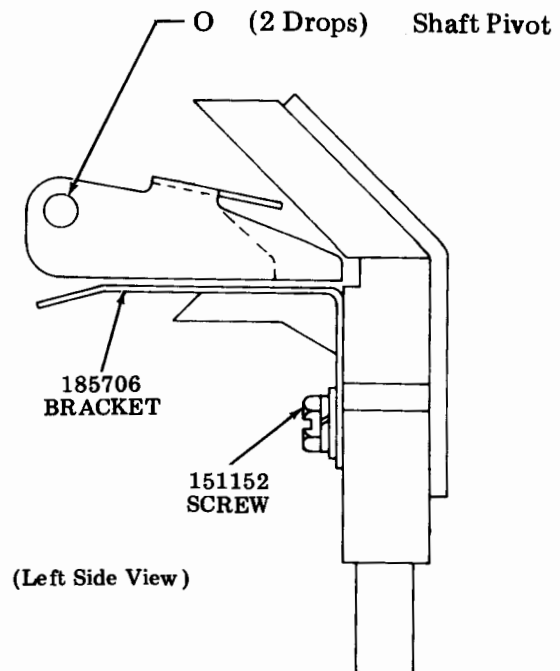
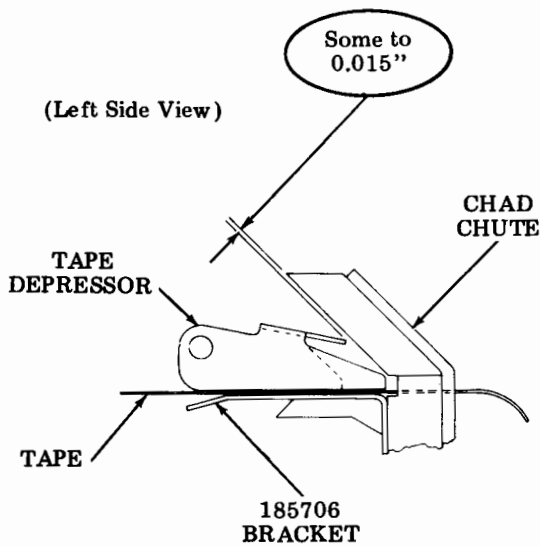

Figure 10 - 185705 Tape Guide Kit

I. 185983 Modification Kit — To Equip Model 33 Friction Feed Typing Units With Carriage Return on Line Feed

2.45 The 185983 modification kit will cause the typing unit to line feed and return the carriage to the left margin whenever the line feed code is received. The line feed code may be generated from the local line feed key or come from a distant station. The kit saves generating the carriage return code after line feed and may be activated at any character position.

2.46 In operation, the modified unit performs the standard line feed function, only, the line feed lever now activates the carriage return and line feed functions simultaneously (see Figure 11).

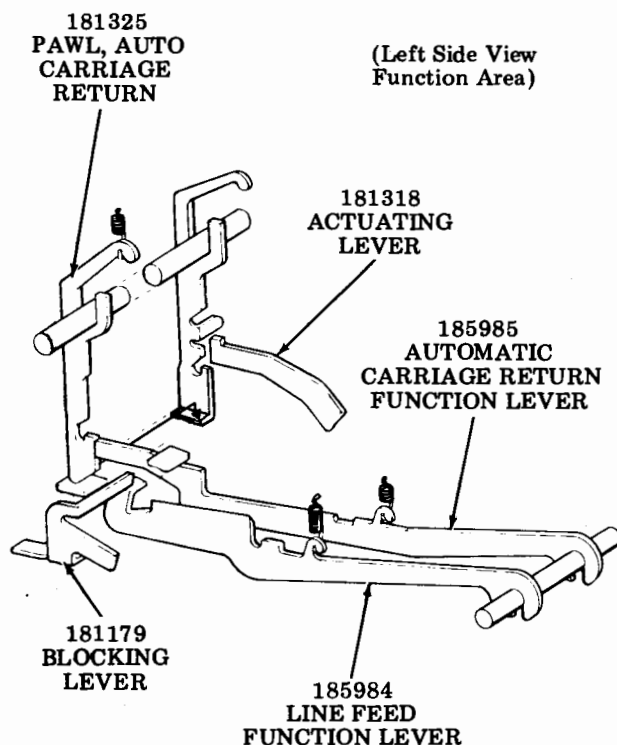

Figure 11 - 185983 Modification Kit to Provide Carriage Return on Line Feed

2.47 Instructions for installing the 185983 kit are included in Specification 50495S. Reverse the instructions in the specification for removal of the kit. Parts information for the kit is also in the specification. Adjustment of

the line feed drive arm and line feed upstop is required after installation of the kit. Refer to Section 574-122-700TC. The lubrication interval of the kit is the same as the typing unit. Refer to the appropriate section.

Note: Typing units equipped with the 185983 kit cannot have the automatic carriage return/line feed feature.

J. 186136 Modification Kit — To Operate Model 33 Private Line Sets With DATA-PHONE and Private Line Data Sets

2.48 The 186136 modification kit provides a means for the interconnection of Model 33 Terminals and data sets which conform to the EIA Standard RS-232-C (Electronic Industries Association). The terminals to be modified must have the answer-back feature and a UCC6 Call Control Unit (or equivalent).

2.49 A terminal modified with the 186136 kit accepts current-no current data and control signals from the teletypewriter and converts them into suitable polar signals for use by the data set. In addition, it accepts polar data and control signals from the data set and converts them into current-no current signals for use by the teletypewriter.

2.50 This kit permits the terminal to operate in either the manual or automatic-answer mode. The kit is intended for use with Bell System 103A, E, and F Data Sets, or equivalent.

2.51 The 198420 modification is similar to the 186136 kit. The basic difference between the kits is that the 198420 kit does not have the possibility of automatic answer.

2.52 The 312418 data set coupler is the basic unit of the modification kit (Figure 12). This basic unit has the power supply, printed circuit board, and a housing. Additionally there is a relay assembly that includes a motor control relay and line local relay, a cable assembly, and some mounting hardware.

2.53 Wiring information for the 186136 kit is in 7454WD, 7455WD, and 8021WD. Parts information and the instructions for installing the kit are in Specification 50630S.

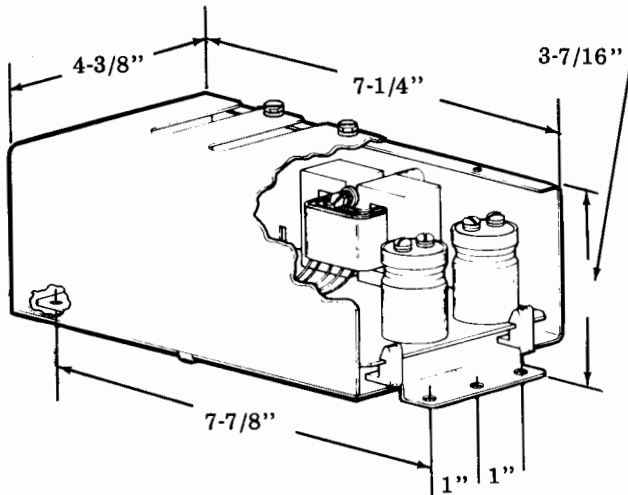
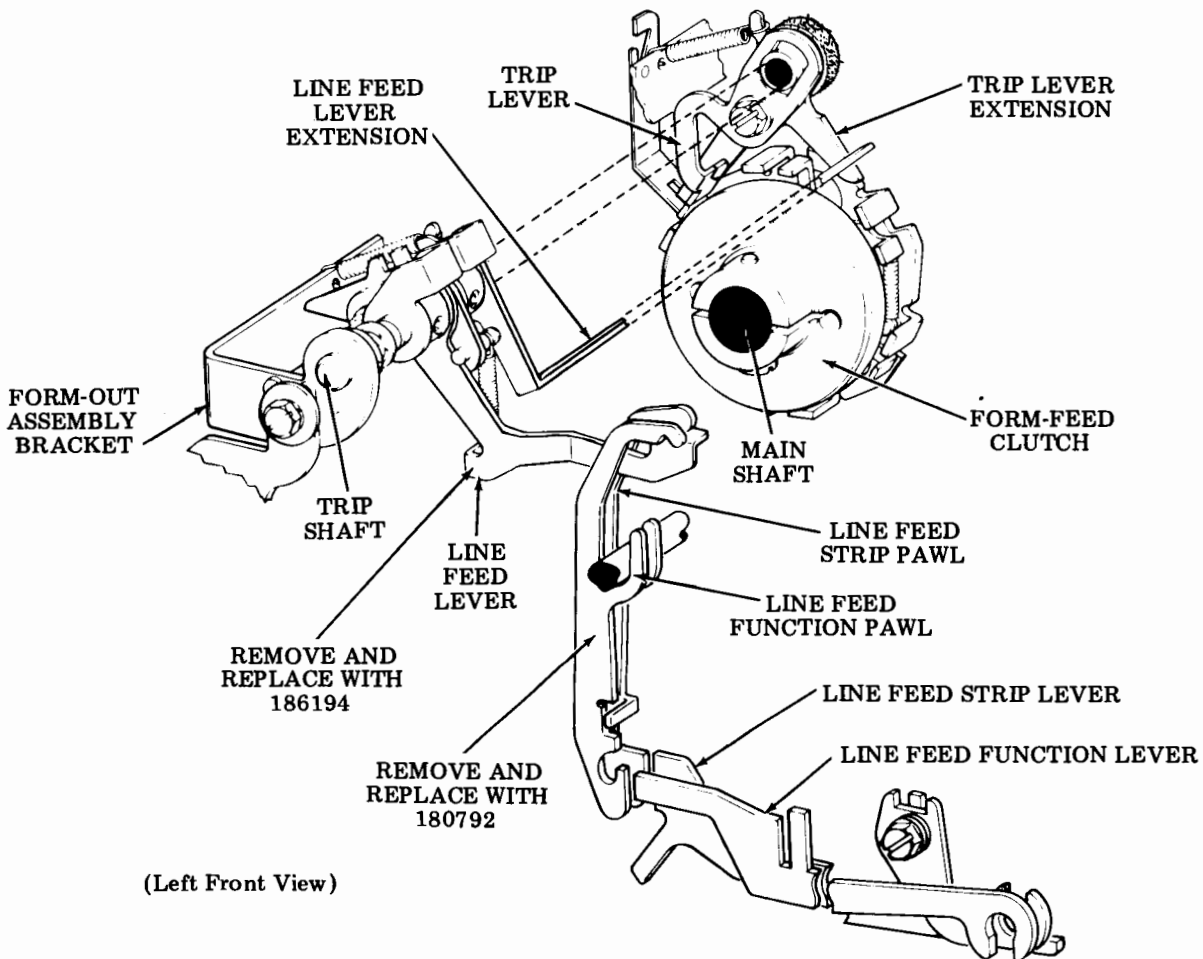

Figure 12 - 312418 Data Set Coupler
(Part of 186136 Kit)

K. 186185 Modification Kit — To Convert Model 33 Sprocket Feed Typing Unit Form-Feed Rate From Six Lines Per Main Shaft Rotation to Three Lines

2.54 The 186185 modification kit is applicable only to sprocket feed typing units. A typing unit equipped with the 186185 kit has a form-feed rate of three lines per main shaft rotation instead of the standard Model 33 six lines per main shaft rotation. A modified typing unit may be used in a systems network having three lines per main shaft rotation.

2.55 Operation of the modified form-feed mechanism is the same as described in Section 574-122-100TC except that the 6-stop clutch is replaced with a 3-stop clutch and an appropriate pair of gears is replaced in the sprocket feed mechanism (Figures 13 and 14).



(Left Front View)

Figure 13 - Form-Feed Mechanism (Sprocket Feed) (186136 Modification Kit)

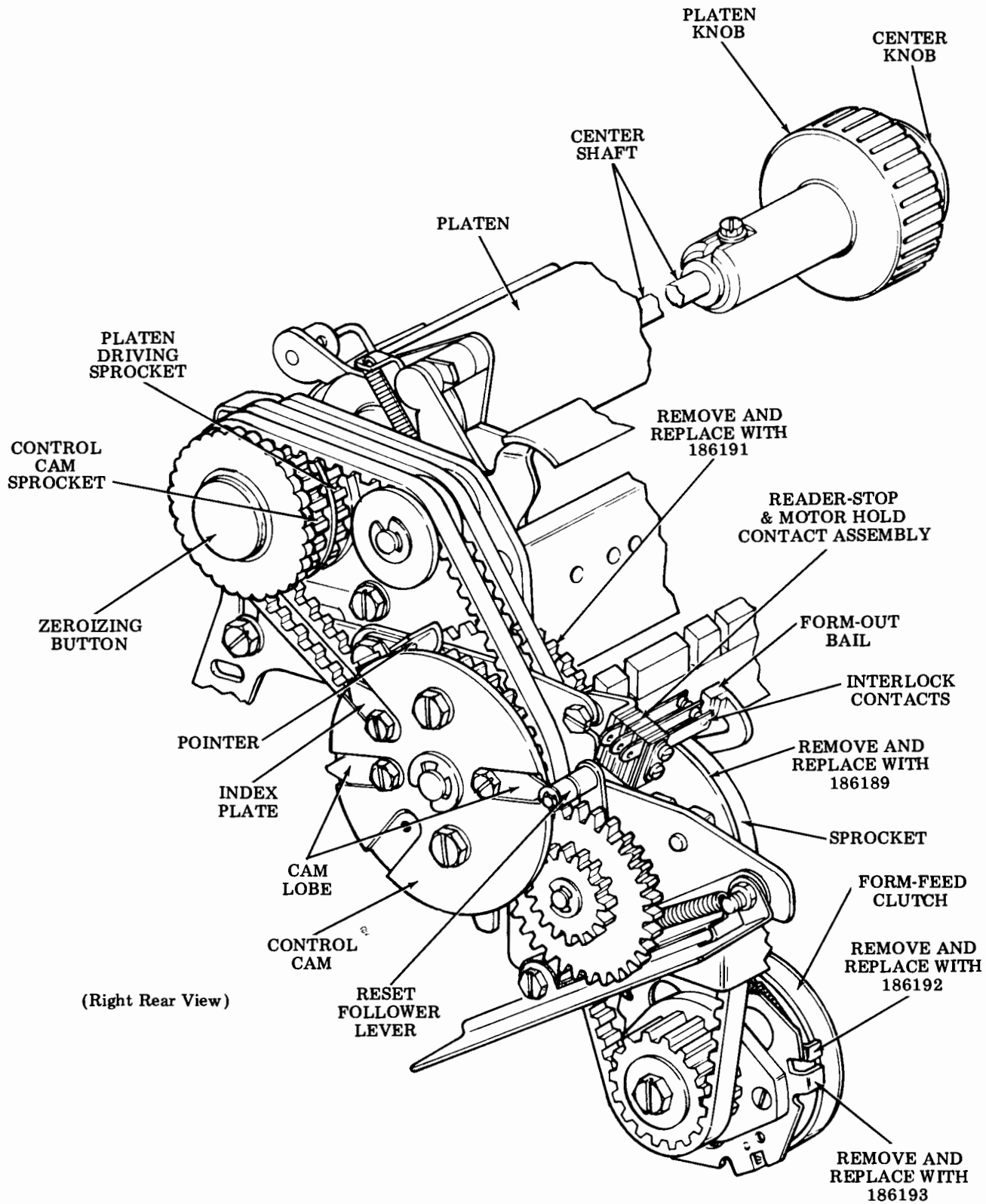

Figure 14 - Platen Drive Mechanism (Sprocket Feed) (186136 Modification Kit)

SECTION 574-100-104TC

2.56 Parts information and installation instructions are in Specification 50656S. This kit is not included in Section 574-122-800TC; however, the standard form-feed mechanism is shown.

Note: Do not make the Armature Bracket Position or Line Feed Pawl Stripping - S adjustments given in Section 574-122-700TC on units modified with this kit.

2.57 The following adjustments, given in Section 574-122-700TC, are to be made after installation of the kit:

Gear Backlash
Belt Tension
Brush Holder Gap
Shaft Left Bearing Gap
Trip Shaft Position
Clutch Shoe Lever Gap
Brush Holder Position
Left Bearing Position
Selector Cam Endplay
Function Clutch Position
Function Clutch Endplay
Codebar Clutch Endplay
Clutch Shoe Lever Gap - S
Trip Shaft Endplay - S
Line Feed Lever Line-Up and Endplay - S
Form-Out Lever Overtravel - S
Cam Lobe Position - S
Driven Gear Line-Up
Codebar Clutch Trip Lever Line-Up
Trip Shaft Latch Lever Endplay
Codebar Clutch Trip Lever Engagement
Function Clutch Trip Lever Engagement
Codebar and Function Clutch Shoe Lever Gaps
Shoe Lever Gap and Trip Lever Engagement
Rocker Shaft Position and Endplay
Bearing Alignment
Main Shaft Rotation
Cam Zero Position - S
Reset Follower Lever Reset Position - S
Trip Lever Engagement - Form-Out - S
Form-Out Lever-Reset Clearance - S
Trip Lever Engagement - Line Feed - S
Trip Lever Upstop Position - S
Line Feed Selection - S

Note: Make the Line Feed Selection - S adjustment, only, use the following requirements in place of those given in Section 574-122-700TC:

0.145 inch to 0.160 inch for single line feed,
0.010 inch to 0.090 inch for double line feed.

2.58 Lubricate the typing unit main shaft, distributor shaft area, and form-out mechanism as given in Section 574-122-701TC.

2.59 If it becomes necessary to disassemble the kit, reverse the installation procedure given in the Specification 50656S packed with the kit.

L. 186226 Modification Kit - To Provide Model 33 Set With Mobility

2.60 The 186226 modification kit provides a set of casters for a Model 33 Set when it is necessary that the set be easily moved between operating locations (Figure 15).

2.61 This kit may be installed on any standard Model 33 Set using only a screwdriver and wrench; the kit does not require any cabinet workover, and retains about the normal keyboard height.

2.62 There is a brake on the two front casters of the kit for use during unit operation. (See Figure 15.)

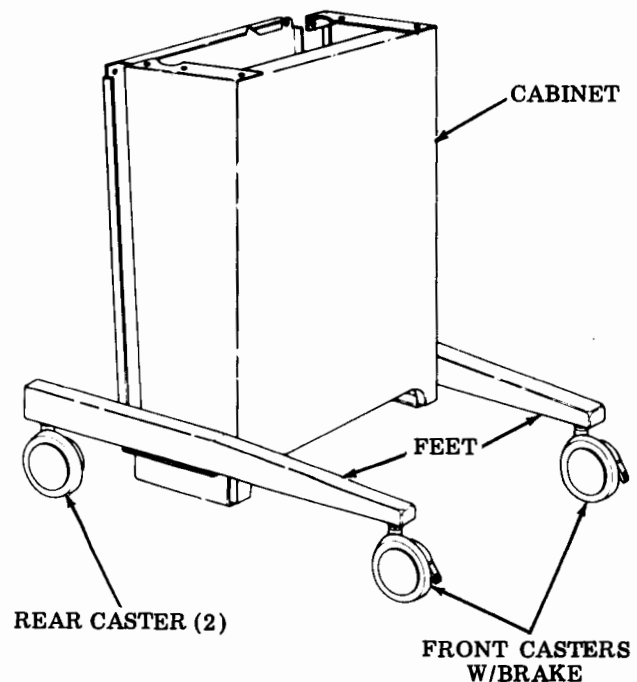

Figure 15 - 186226 Modification to Provide Mobility

2.63 There are no adjustments required after installation of the kit. During installation of the kit, make certain the 186238 foot fits closely against the side of the cabinet (see Section 574-126-800TC). This modification requires no lubrication.

2.64 Specification 50626S has the installation instructions for the kit and if it should become necessary to remove the kit, reverse the installation procedures.

M. 186241 Modification Kit — To Convert Model 33 Private Line ASR Sets to Automatic Reader Control

2.65 The 186241 modification kit converts the Model 33 Private Line ASR Sets to Automatic Reader Control. The automatic control features allow the tape reader to be stopped or started either manually or automatically, locally, or from a distant station.

2.66 There are four control positions on the tape reader with the 186241 kit installed. The positions are explained in 2.67 through 2.70. (See Figure 16.)

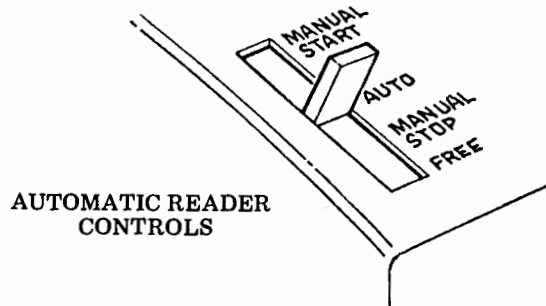

Figure 16 - 186241 Kit Controls

2.67 In the automatic mode the spring biased handle is normally in the automatic position (AUTO) and automatic operation occurs. The reader responds to ASCII control codes as follows:

- DC1 or X-ON — Automatically turns reader on.
- DC3 or X-OFF — Automatically turns reader off.
- ENQ or WRU — Stops reader and calls in remote answer-back. If DC1 is received at the end of the answer-back transmission, the interrupted reader will automatically restart.

2.68 To activate the reader without receiving the signal code DC1 (MANUAL START), the handle is moved to the MANUAL START position. The reader will then operate, with switch returning to AUTO position when released.

2.69 To manually stop the reader, the handle is moved to the MANUAL STOP position. Handle will return to AUTO when released.

2.70 The FREE position allows the tape to be moved manually, for repositioning. The switch must be returned manually from the FREE position to AUTO.

2.71 When preparing a tape, any control function, except information separators, should be followed by two delete characters (may also be "rubout").

2.72 Description and operation of a tape reader with automatic control is given in Section 574-124-100TC.

2.73 There are no adjustments or lubrications peculiar to the 186241 kit. The tape reader adjustments in Section 574-124-700TC should be made after installation of the kit. The newly installed function levers of the kit should be lubricated in accordance with Section 574-124-701TC.

2.74 This modification consists mainly of the installation of function levers, pawls, and a switch in the typing unit function area; a circuit card in the call control unit; a contact block assembly in the reader; and a new reader cover.

2.75 Instructions for installing the 186241 kit are in Specification 50634S; in case it becomes necessary to remove the kit, reverse the installation procedures.

N. 186776 Modification Kit — To Provide a Handle for Model 33 Typing Unit

2.76 The 186776 modification kit provides a handle that attaches to the left-rear corner of the typing unit casting to assist in the installation or removal of the unit only (Figure 17).

2.77 With the carriage to the left, the right side of the carriage rail may be used as a lifting point.

Note: Take care not to distort the belt.

2.78 Installation information is in Specification 50714S. Reverse the installation instructions to remove the kit.

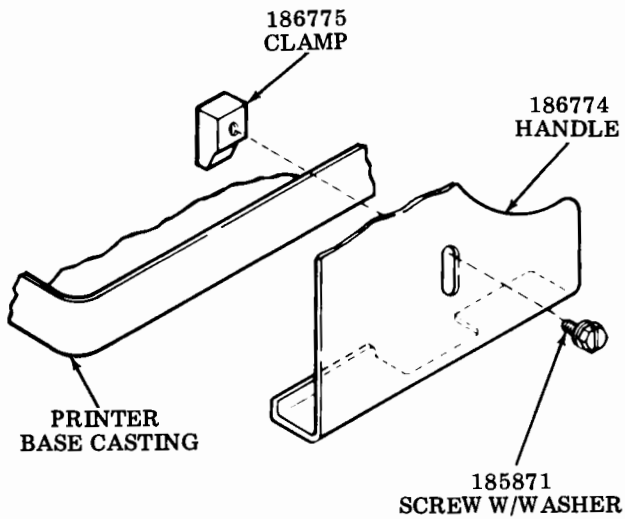

Figure 17 - 186776 Handle Modification Kit

O. 187125 Modification Kit — To Provide 48 V AC 24 V DC Magnet Controlled Answer-Back Trip Mechanism for Model 33 Typing Unit

2.79 The 187125 modification kit provides a magnetic answer-back trip coil for "standardized" Model 33 KSR or ASR Sets that did not come from the factory so equipped. The customer must provide a means of energizing the coil. (See Figure 18.)

2.80 The dc coil requires external arc suppression. Since coil drop-out time is not critical, a diode is recommended.

2.81 In order to provide reliable operation of the mechanism, the operating voltage should not vary more than +10 percent from the nominal specified, and the minimum duration of the operating pulse should be 30 milliseconds. A mechanical latch-interlock system allows the answer-back mechanism to reset at the end of answer-back transmission even though the

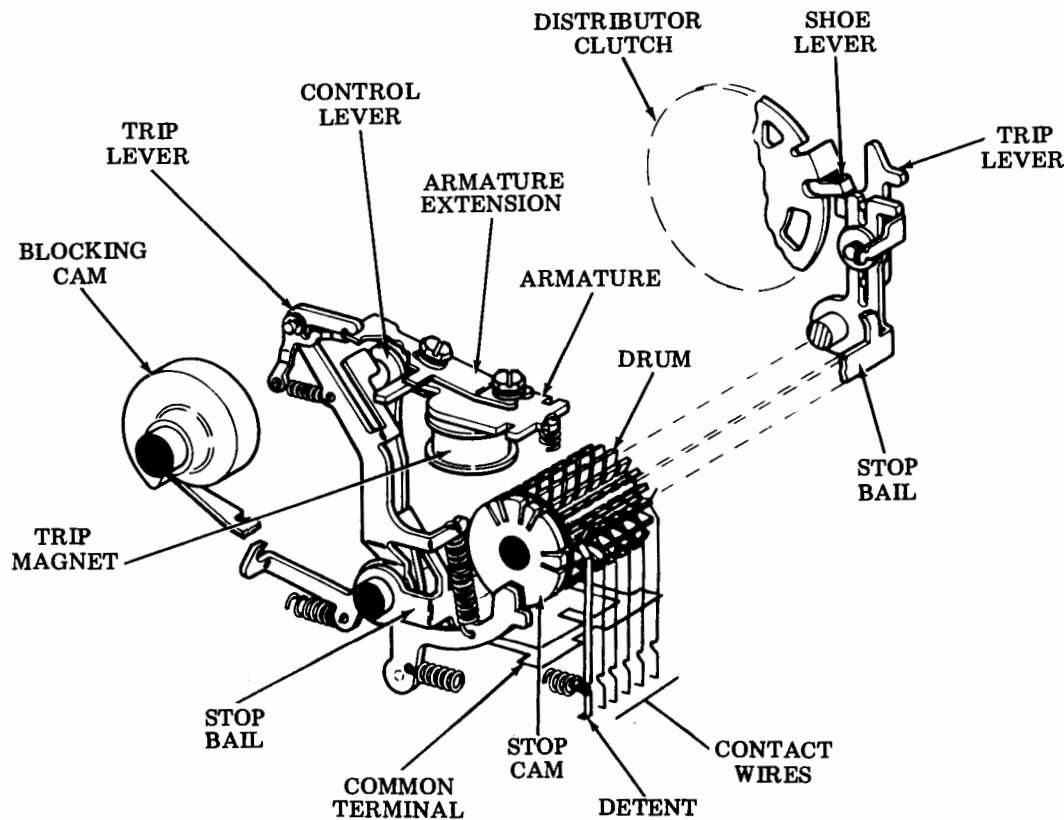

Figure 18 - 187125 Answer-Back Trip Modification Kit

magnet armature remains attracted, therefore, there is no maximum pulse length requirement. However, the coil must be de-energized before retripping the mechanism.

2.82 Specification 50746S contains part information, installation instructions, adjustments, and lubrication procedure. Reverse installation instructions for removal of the kit.

P. 194822 Directory Holder for Model 33 KSR and ASR Cabinets

2.83 The 194822 directory holder provides convenient storage for directories and like materials on KSR and ASR cabinets.

2.84 The holder attaches to the right side of the cabinet by removing backing from a double-sided adhesive tape and pressing into position. See Figure 19 and refer to Specification 50602S.

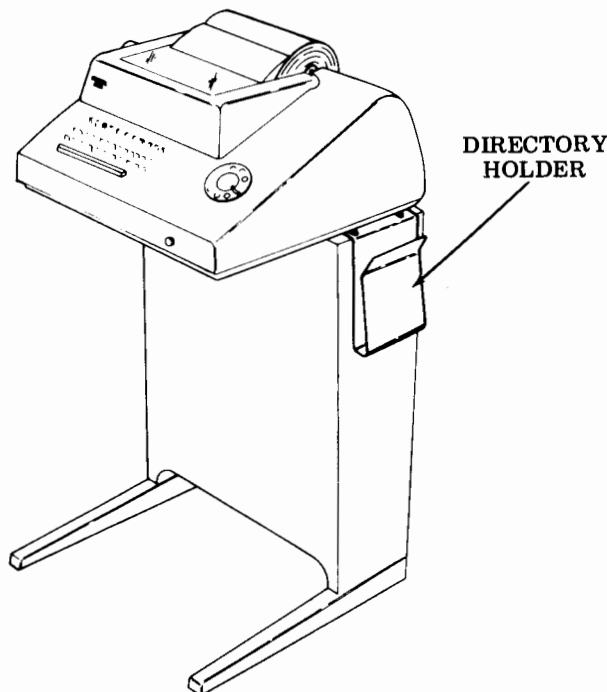

Figure 19 - Cabinet With 194822 Directory Holder

Q. 198420 Modification Kit — To Connect TELETYPE Terminal Apparatus to 103 Series Data Sets, or Equivalent

2.85 The 198420 modification kit provides facilities for the interconnection of TELETYPE terminal equipment and data sets which conform to the standard of the Electronics Industries Association. In accordance with these standards, all data and control leads of the data set carry bi-polar voltage signals. See Figure 20 for a pictorial view of a typical installation.

2.86 The 198420 kit accepts current-no current data and control signals from the teletypewriter and converts them into suitable bi-polar signals for use by the data set. In addition, it accepts polar data and control signals from the data set and converts them into current-no current signals for use by the teletypewriter.

2.87 The 198420 kit provides for the manual answer mode of operation. The basic unit in the kit is the 312418 data set coupler (see Figure 12). There are also two connectors and some terminals in the 198420 kit. The principle difference between the 198420 kit and the 186136 kit described in 2J. of this section is that the 186136 kit has both manual and automatic answering mode while 198420 kit provides only the manual answer mode.

2.88 It is recommended that signal generators equipped with gold-plated contacts be used in conjunction with this coupler. Although the circuit is designed to accommodate a relatively high voltage drop in the BA circuit, tests have shown that tungsten contacts can exhibit complete nonconductivity under some operating conditions.

2.89 The 198420 kit is for use with Bell System 103 A, B, C, E, and F Data Sets, or their equivalent. All should have the EIA interface. A power cord is provided to connect ac power to the coupler.

2.90 Wiring information for the 198420 kit is in Wiring Diagram 6468WD. Instructions for installing the 198420 kit are in Specification 50248S. The installation of the kit is mainly electrical, a simple cable must be made up, and the cabling terminates in an EIA standard 25-pin connector. Should it be necessary to remove the kit, reverse the instructions in Specification 50248S and 6468WD.

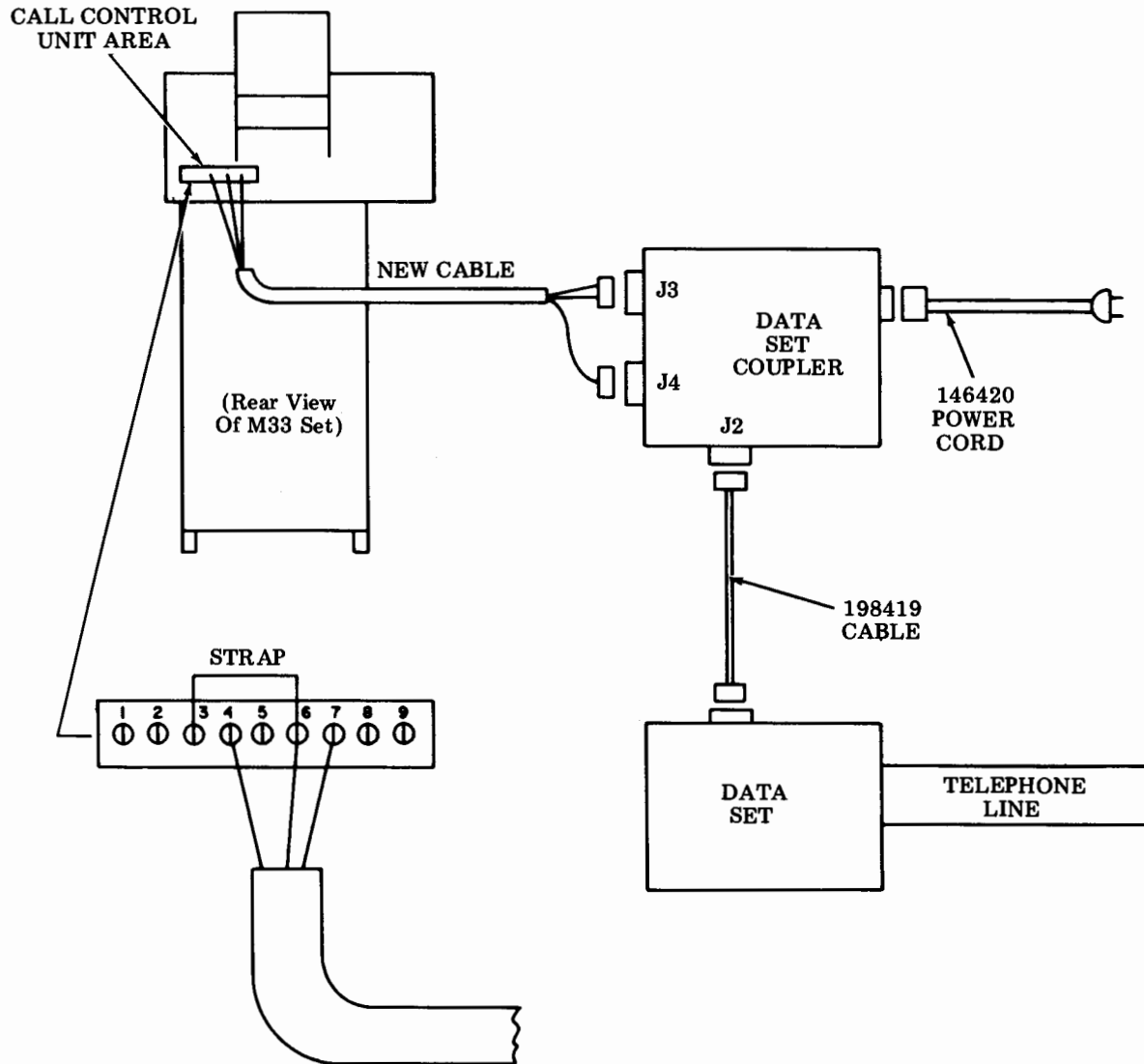

Figure 20 - Pictorial View of Installation of Kit 198420

R. 199931 Modification Kit — To Provide Model 33 ASR Sets With an Intermediate Tape Storage Bin

2.91 The 199931 modification kit provides an intermediate tape storage bin holding approximately 100 feet of perforated tape between the tape punch and the tape reader on the left side of a Model 33 ASR Set. See Figure 21.

2.92 There is a chad container in the rear of the tape bin.

2.93 The tape storage bin kit comes assembled from the factory and mounts on the ASR set by an upper and lower guide which slide into position.

2.94 The start of a tape message is clamped in the reader under the tape lid. After feeding out about one foot of tape, make certain that the tape goes into the bin.

2.95 The tape is stuffed into the bin by the feeding action of the tape punch.

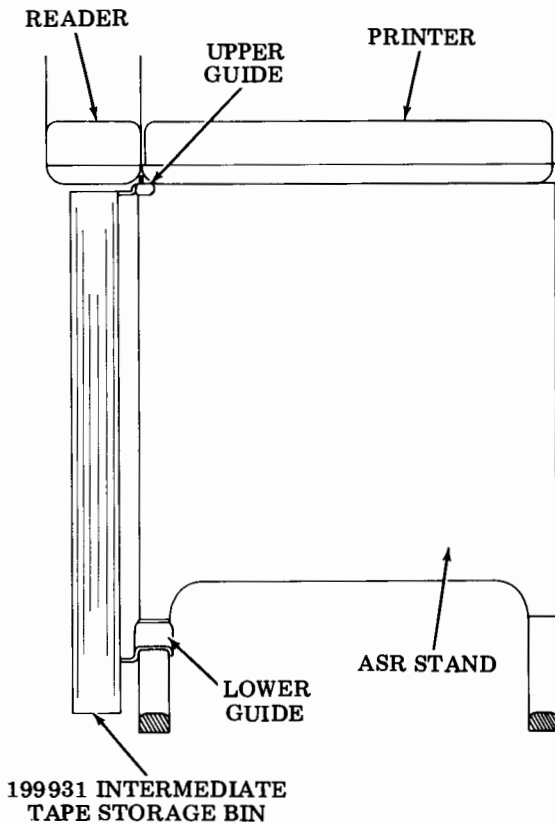

Figure 21 - 199931 Tape Storage Bin Modification

2.96 After the message is punched, it may be transmitted by starting the reader which will pull the tape out of the bin with the beginning of the message first.

2.97 The chad container at the upper rear of the tape storage bin should be emptied every time a new roll of tape is placed on the machine or any convenient time afterwards when the tape bin is empty.

2.98 Instructions for installing the 199931 kit are in Specification 50403S. Should it become necessary to remove the kit, reverse the installation procedure. Parts information is in Section 574-126-800TC.

S. 333521 AC Series Motor Assembly for Model 33 Sets

2.99 The 333521 motor assembly is for use in driving Model 33 Terminals where regulated 50/60 hertz alternating current is not available. If the frequency is not regulated when

synchronous motors are used, speed variations occur which result in printing errors.

2.100 The 333521 motor assembly does not provide radio frequency suppression filter or shielding.

2.101 The 183991 motor, of the motor assembly, is a 1/12 horse power single phase 115 volt ± 10 percent ac series type intended to operate at 3600 rpm using a speed regulator. The motor has ball bearings. The input current of the motor assembly is as follows:

	60 Hertz	50 Hertz
Starting Input	2.2 ampere	2.5 ampere
Running Input (full load)	1.0 ampere	1.1 ampere

2.102 This motor assembly uses a governor with a centrifugal switch, and if the speed exceeds 3600 rpm, contacts open until the motor slows (Figure 22). There is a stroboscopic target to assist in adjusting the speed to 3600 rpm.

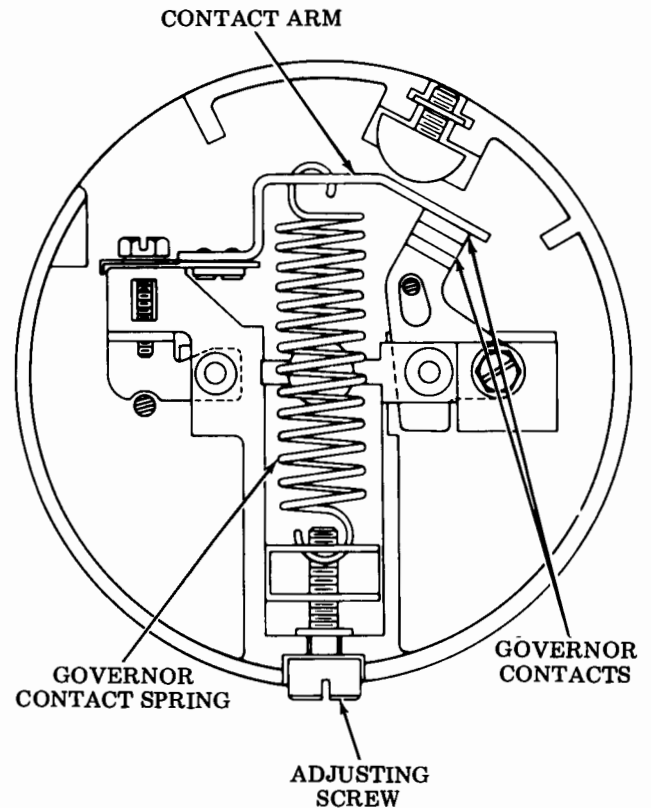

Figure 22 - 333521 Motor Assembly Governor

SECTION 574-100-104TC

2.103 The description and principles of operation of a series governed motor are in Section 570-220-100TC.

2.104 Adjustments required for the motor assembly are in Section 570-220-701TC. Lubrication procedures for the motor assembly are in Section 574-220-702TC.

2.105 The installation and wiring information for the 333521 motor assembly is in Specification 50702S. Each assembly comes from the factory with a specification. The specification also contains parts information.

T. 343691EW Modification Kit — To Provide a Shelf for Attendant Set on Model 33 KSR or ASR Set

2.106 The 343691EW modification kit will mount a telephone or other attendant set such as a Bell System 103G or 113A Data Set or an 804A Data Auxiliary Set, or equivalent, on Model 33 KSR or ASR Sets (Figure 23).

2.107 Instructions for installing and removing the 343691EW kit are in Specification 50768S. Parts information for the kit is in Section 574-126-800TC and Specification 50768S.

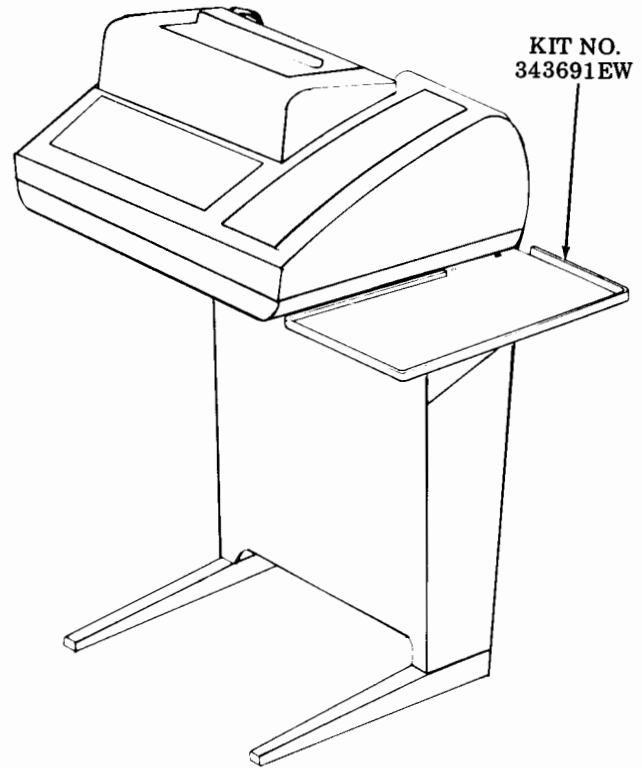

Figure 23 - 343691EW Modification Kit Mounted on a Model 33 KSR or ASR Set

33 TELETYPEWRITER SETS

CIRCUIT DESCRIPTIONS

CONTENTS	PAGE	CONTENTS	PAGE
1. GENERAL	2	EOT DISCONNECT CIRCUITS	11
2. SWITCHED NETWORK SERVICE	2	RINGER AND OFF-HOOK CIRCUITS	11
TEST CIRCUIT	2	OUT OF SERVICE CIRCUIT	12
BREAK RELEASE CIRCUIT	2	PAPER ALARM CIRCUIT	12
RESTRAIN CIRCUIT	3	POWER CIRCUITS	13
CLEAR KEY CIRCUIT	3	3. CIRCUIT SWITCHING SERVICE	13
ANSWER CIRCUITS	3	POWER SUPPLY CIRCUIT	13
A. Automatic Answer	3	LOCAL-REMOTE CONTROL CIRCUITS	13
B. Manual Answer	3	A. Proceed-to-Dial Circuit	14
ORIGINATE CIRCUIT	4	B. Connect Circuit	15
ROTARY DIAL OR PULSING CARD		C. Local Circuit	17
DIALER CIRCUIT	4	MOTOR DELAY TIMER CIRCUIT	17
A. On-Hook	4	SELECTOR MAGNET DRIVER CIRCUIT	19
B. Originating a Call	4	NEUTRAL SIGNALING	20
C. Answering a Call	5	A. Circuit Interconnections	20
"TOUCH-TONE"* DIALER CIRCUIT	5	B. Idle Line Condition	21
SPEAKER AMPLIFIER CIRCUIT	5	C. Initiating a Call	22
SIGNAL GENERATOR CIRCUITS	6	D. Connection	23
A. Signal Line Circuit	6	E. Disconnect	24
B. Signal Generation Circuit	7	F. Local Off-Line Operation	24
C. Control and Shift	8	POLAR ADAPTER	24
SELECTOR MAGNET DRIVER CIRCUIT	8	A. General	24
LOCAL AND MOTOR CONTROL CIRCUITS	9	B. Receiving Polar Relay	25
READER CONTROL CIRCUITS	9	C. Sending Polar Relay	26
ANSWER-BACK CIRCUITS	11	D. Connect Control Timer	26
		E. Current Amplifier	27
		F. Circuit Interconnections	28
		G. Idle Line Conditions	28

*Service mark of AT&T Company

CONTENTS	PAGE
H. Initiating a Call	28
I. Proceed-to-Dial	28
J. Dialing	29
K. Call Connection	29
L. Remote Connection	30
M. Call Disconnect	31
N. Remote Disconnect	31
O. Local Off-Line Operation	31
4. PRIVATE WIRE SERVICE	31
INTRODUCTION	31
A. Power Switch and Local Power Supply Circuits	31
B. Mode Chart	31
OFF MODE	31
A. Power Circuit	31
B. Signal Circuit	33
LOCAL MODE	33
A. Power Circuit	33
B. Signal Circuit	33
LINE MODE	33
A. Power Circuit	33
B. Signal Circuit	33
1. GENERAL	
1.01 This section explains how various circuits are electrically coupled to a teletypewriter set, to a telegraph network or, through a data set to a telephone network.	
1.02 All circuit descriptions are made with respect to specific wiring diagrams. Alpha numeric references found in parentheses are used to locate major components or circuits on the wiring diagrams. An example of an alpha numeric reference is (3C4), and should be read as follows:	
(a) The number 3 designates the sheet on which the particular circuit or component is located.	
(b) The letter and number combination C4 indicates the horizontal and vertical coordinates where the component or circuit is located.	
2. SWITCHED NETWORK SERVICE	
2.01 The KSR, ASR, and RO Teletypewriter Sets used in switched network service operate in conjunction with either a 101C or 105A data set and a call control unit.	

General descriptions and operations of the call control unit or either data set can be found in the appropriate sections.

2.02 The following circuit descriptions should be used with reference to 7882WD for KSR and ASR sets and 7881WD for RO sets.

TEST CIRCUIT

2.03 Operating the TST (test) pushbutton while the set is connected to a test center permits the message sent by the test center to be recorded by the typing unit and, at the same time, turned around and sent back to the test center for analysis.

2.04 The TST pushbutton is a locking type and may be released by momentarily depressing any of the five other pushbuttons in the six pushbutton set. When operated, the normally open contacts 23 and 24 (1D4) close to complete the 10-volt circuit through the TST lamp (located under the pushbutton) to ground.

2.05 The normally closed contacts 22 and 23 open to remove the data set from ground and disable timed disconnect-on-spacing feature. This is necessary to prevent a disconnect, should a steady spacing signal be included in a test.

2.06 The normally closed contacts 19 and 20 open to remove the keyboard or transmitter signal output at the send break timer from the modulator in the data set. The normally open contacts 19 and 21 close a circuit from the demodulator to the modulator, so that demodulated signals from the test center are modulated and sent back to the test center.

BREAK-RELEASE CIRCUIT

2.07 Set connected to 101C data set: The BRK-RLS (break-release) lamp lights when the RB (receive-break) relay operates, closing the RB make contacts. This completes the circuit from 14 v ac through the BRK-RLS lamp, the RB make contacts, and the S break contacts to ground.

2.08 The RB and the S (send space) relay operate after the CLR (clear) pushbutton is depressed. The BRK-RLS lamp may flash momentarily at this time. The opening of the S break contacts will prevent the BRK-RLS lamp from remaining on during the clear sequence.

2.09 Set connected to 105A data set: The SO (send space - normally operated) relay operates when the set is turned on. The BRK-RLS lamp lights when the RR (receive break - normally released) relay operates. The RR relay closes its make contacts which complete the circuit through 14 v ac through the BRK-RLS lamp, the RR make contacts, and SO make contacts to ground.

2.10 The RR relay operates and the SO relay releases after the CLR pushbutton is depressed. The BRK-RLS lamp may flash momentarily at this time. The opening of the SO break contacts prevent the BRK-RLS lamp from remaining on during the clear sequence.

RESTRAIN CIRCUIT

2.11 The REST (restrain) lamp lights when the RS (restrain signal) relay in the data set is energized. On a "break," which originates in the data converter, the REST and BRK-RLS lamps are both lighted.

Note: This circuit is found in KSR and ASR sets only.

CLEAR KEY CIRCUIT

2.12 Set connected to 101C data set: Momentarily depressing the nonlocking CLR pushbutton closes contacts 11 and 12. This will complete the circuit to ground in the following ways:

- (a) **Answer Mode:** The circuit is completed through the AN (answer) make contacts.
- (b) **Originate Mode:** The circuit is completed through the AN break contacts and the OR (originate) make contacts.

2.13 The complete circuit path is through the contacts mentioned in 2.12 (a) or (b), CLR contacts 11 and 12, the RB (receive break) contacts, and the RB relay to -20 v dc.

2.14 When the RB relay operates, the RB make contacts provide a holding circuit for the relay to ground through the AN make or AN break contacts and the OR make contacts, depending on the mode of the set. Other RB make contacts close to complete the circuit from ground through the AN make or AN break contacts, the OR make contacts, CLR contacts 11 and 12, RB make contacts, and the S relay to -20 v dc. The S relay operates and remains energized through the holding path provided by the AN make or AN break contacts and the OR make contacts. The S make contacts close and the CLR lamp will light. A timer circuit de-energizes the S relay after 700 milliseconds, the S make contacts open, and the clear lamp will turn off.

2.15 Set connected to 105A data set: The RO (receive break) and SO (send break) relays are normally operated, as designated by the letter O in RO and O in SO. When the CLR pushbutton is momentarily depressed, contacts 11 and 12 complete the circuit from ground through the CLR contacts, the RO make contacts, and the RR relay to -20 v dc. The RR relay operates and remains energized through its holding contacts.

2.16 The RR break contacts open the circuit to the RO relay and release the relay. The RO break contacts close the circuit from ground through the CLR contacts 11

and 12, the RO break contacts, and the SR relay to -20 v dc. The SR relay operates and is held by the SR make contacts. The SR make contacts (in series with the OH make contacts) close and light the CLR lamp. A timer circuit causes the OH (off hook) relay to release and turn off the CLR lamp.

ANSWER CIRCUIT

2.17 When a set is called, an ac ringing current, sent from the central office, energizes the RU (ring up) relay. The set may then be put into the answer condition either automatically or manually.

A. Automatic Answer

2.18 With the RU relay energized, the ANS (answer) lamp is lighted by the closure of the RU make contacts, which completes the circuit from ground through the lamp to +20 v dc.

2.19 Set connected to 101C data set: With the set in the automatic answer condition, there is a circuit path from -20 v dc through the AN (answer) relay, the RU make contacts, the CY (copy) break contacts, and CP17 to ground. The AN relay is held energized by the ground applied to its make contacts. The ANS lamp remains on because of the ground applied through the series connected AN make contacts and S break contacts.

2.20 The ANS lamp goes off when the S relay operates after the CLR pushbutton is depressed, or on the end of transmission code. The opening of the S break contacts in series with the S make contacts will turn off the ANS lamp. When the S relay operates, the S break contacts place a resistor in the circuit; the S make contacts provide a path to ground through the timer. After the timing interval during the disconnect sequence, the timer causes the AN relay to release by completing the path to ground which short-circuits the relay.

2.21 Set connected to 105A data set: With the set in the automatic answer condition, there is a circuit path from +20 v dc through the OH relay, the OR break contacts, the RU make contacts, the CY break contacts, and through CP17 to ground. The OH relay operates and is held energized by the circuit path through its make contacts, the SO make contacts, and the TM (timer) break contacts to ground.

2.22 The ANS lamp turns off when the SR relay is operated by depressing the CLR pushbutton, or at the end of the transmission code. The SR break contacts in series with the OR break contacts open to turn the lamp off. The OH relay releases when the SO make contacts and the TM break contacts open during the clearing sequence.

B. Manual Answer

2.23 The automatic answer feature is disabled when any one of the following contacts in the circuit through the AN or OH relay and the RU make contacts to ground is opened.



<u>CONDITION OF SET</u>	<u>CONTACTS OPEN</u>
-------------------------	----------------------

Local, originate, or test modes	CY break
Low paper	Low paper switch
Out of service	Out of service
Feeding forms or tabulating	Vertical tabulation and form out

2.24 During the ringing interval, the RU relay operates causing the ANS lamp to flash and the ringer to sound. The RU relay releases during the silent interval. (If the set is out of service, no ringing will take place.)

2.25 The ANS pushbutton is depressed to answer a call. (If the set is feeding forms or tabulating at this time, the set will automatically answer after the operation is completed.) The ANS pushbutton is nonlocking, and its contacts 17 and 18 (1D7) close momentarily.

2.26 Set connected to 101C data set: Closure of the ANS pushbutton completes the circuit from ground through the S and OR break contacts, ANS contacts 17 and 18, and the AN relay to -20 v dc. The AN relay then operates and is held energized by the ground applied by the AN make contacts. Subsequent operation is the same as the automatic answer described in 2.19 and 2.20.

2.27 Set connected to 105A data set: Depressing the ANS pushbutton completes the circuit from ground through the SO make contacts, the ANS contacts 17 and 18, the OR break contacts, and the OH relay to +20 v dc. The OH relay operates and is held energized by the OH and SO make contacts to ground. Subsequent operation is the same as the automatic answer as described in 2.21 and 2.22.

ORIGINATE CIRCUIT

2.28 The RO set goes into the originate mode but has no amplifier.

2.29 Depressing the nonlocking ORIG (originate) pushbutton momentarily closes contacts 5 and 6 (1E7). This will start the following operations, provided the set is not in an answer condition.

2.30 Set connected to 101C data set: Depressing the ORIG pushbutton completes the circuit from ground through the S and AN break contacts, the ORIG contacts, and the OR relay to -20 v dc. The OR relay then operates and is held energized by the OR make contacts and AN break contacts to ground. The closure of the OR make contacts in series with the S break contacts turn on the ORIG lamp and makes the speaker amplifier operable by turning on output transistor Q2 (2E6).

2.31 After the CLR pushbutton is depressed, or upon receipt of the end of transmission code, the S relay operates and its break contacts (in series with the OR make contacts) open to turn off the ORIG lamp and disable the speaker amplifier. The OR relay releases during the disconnect sequence in the same manner as the AN relay releases as described in 2.20.

2.32 Set connected to 105A data set: Depressing the ORIG pushbutton completes the circuit from ground through the SO make contacts, the OH break contacts, the ORIG contacts 5 and 6, and the OR relay to +20 v dc. The OR relay then operates, its make contacts close and the OH relay will operate. The OR relay remains energized when the ORIG pushbutton contacts 5 and 6 open through the holding circuit composed of the OR, OH, and SO make contacts to ground.

2.33 The ORIG lamp lights with the closure of the OR and OH make contacts (in series with the SR break contacts). These contact closures also make the speaker amplifier operable by turning on output transistor Q2.

2.34 After the CLR pushbutton is depressed, or upon the receipt of the end of transmission code, the SR break contacts (in series with the OR and OH make contacts) open, turning off the ORIG lamp and disabling the speaker amplifier. Relays OR and OH release during the disconnect sequence in the same manner as the OH relay in 2.22.

ROTARY DIAL OR PULSING CARD DIALER CIRCUIT

2.35 The following circuit description applies to ASR and KSR sets only.

2.36 When originating or answering a call, the ringer is disconnected and the hybrid transformer is connected, between ring and tip, to present an off hook condition to the central office. Both the rotary dialer and pulsing card dialer have off-normal contacts which close and short circuit the speaker output during dialing. The operator, therefore, will not hear dialing clicks through the speaker.

A. On-Hook

2.37 When the set is in the on-hook condition, the ringer is connected between ring and tip through the AN break and OR break contacts (in the 101C data set) or, through the OH break contacts (in the 105A data set).

B. Originating a Call

2.38 Set connected to 101C data set: the OR relay operates, the OR break contacts open the ringer circuit, and the OR make contacts close the circuit from tip, through the pulsing contacts of the rotary dial (and the pulsing card dialer, if present), and through the hybrid transformer to the ring circuit.

2.39 Set connected to 105A data set: The OH relay operates and the OH break contacts open the ringer circuit. The OH make contacts close the circuit from tip, through the pulsing contacts of the rotary dial (and pulsing card dialer, if present), and through the hybrid transformer to the ring circuit. After the call connection is made, the CR (connect) make contacts or the CO (connect) break contacts close to short circuit the dialer pulsing contacts.

C. Answering a Call

2.40 Set connected to 101C data set: During an automatic answer, the RU (ring up) break contacts (2C2) open and prevent ringing current from reaching the hybrid transformer when the AN contacts close. The AN relay is operated and the AN break contacts open the ringer circuit. The AN make contacts close the circuit from tip, through the OR break contacts, the AN make contacts, the RU break contacts, and the hybrid transformer, to the ring circuit. Since the set is in an answer condition, the dialer pulsing contacts are not in the circuit.

2.41 Set connected to 105A data set: During an automatic answer, the RU (2B2) break contacts open and prevent ringing current from reaching the hybrid transformer when the OH make contacts close. The OH relay is operated and the OH break contacts open the ringer circuit. The OH make contacts close and the CR make or CO break contacts close, completing the circuit from tip through the OH make contacts, the CR make or CO break contacts, the RU break contacts, and through the hybrid transformer to the ring circuit. Since the set is in an answer condition, the dialer pulsing contacts are not in the circuit.

"TOUCH-TONE" DIALER CIRCUIT

2.42 The following circuit description applies to ASR and KSR sets only.

2.43 The tone dialer utilizes a transistor oscillator which generates two frequencies each time a pushbutton on the dialer is depressed. The frequencies of oscillation are determined by the values of inductance and capacitance in tank circuits T1-C1 and T2-C2 (3D4-3D6). Different values of L and C are placed into the tank circuits (by the closure of contacts in each circuit) when the pushbuttons are depressed.

2.44 The tone dialer is made operable only when the set is the originate mode and before the call connection between stations is made. The dialer is made operable by making the base of Q1 (3F5) negative with respect to the emitter, causing the transistor to conduct. The circuit path is from ground through the 200 ohm resistor (connected to the CAL rheostat), RV4, RV3, R1, and into the data set at CN41 to -20 v dc.

2.45 In the 101C data set, this path is provided by the CON make-break and M make-break contacts. In the 105A data set, the path is provided by the CO make-break and MO make-break contacts.

2.46 Once the stations are connected, the dialer is disabled to prevent interference caused by its accidental use. It is disabled by opening the circuit between -20 v dc and the collector of Q1. This turns off Q1 and stops the oscillations. The CON break contacts (in the 101C data set) or the CO make contacts (in the 105A data set) open to break the circuit when the stations connect.

2.47 When a tone dialer is used, the speaker amplifier receives two inputs: the normal telephone line input and a tone dialer input. The telephone line signal path is from the incoming amplifier in the data set through CN31 (in the 101C data set) or CN30 (in the 105A data set) through contacts CS (W2-V) to terminal 1 of speaker amplifier input transformer T1 (3F3). The signal from the secondary winding of T1 is fed through contacts CS (Z-Y) and capacitor C1 to the base of input transistor Q1.

2.48 The tone dialer multifrequency output is applied to the base of input transistor Q1 through capacitors C5 and C1. The speaker amplifier output (dial tone) is applied to both the speaker amplifier and the telephone line through the data set. The circuit path to the telephone line is from the emitter of output transistor Q2, through capacitor C3, contacts CS (T-S), and to the outgoing amplifier in the data set at CN47.

2.49 Depressing a pushbutton on the dialer causes common switch CS to operate and its YZ contacts (3D5) to open. This disconnects the signal input from the telephone line to the speaker amplifier. Common switch contacts ST (3D3) close to connect the amplifier output to the telephone line through the outgoing amplifier in the data set. Contacts W2-V open to prevent the dial tone from reaching the incoming amplifier which would cause a false connect. Contacts W1-U (3C6) open and interrupt the dc current in tank coils T1 and T2. Oscillations then start with a very short build-up time.

2.50 Potentiometer CAL (3E4) is used to adjust the level of multifrequency signals generated by the dialer. It must be adjusted each time the data set is changed.

2.51 Capacitor CAN (3E4) and C4 (3F5) suppress spurious signals in the range of 7 k hz to 14 k hz. These signals are generated during the short time interval when all sensing contacts and the E contacts (3B7) are open.

SPEAKER AMPLIFIER CIRCUIT

2.52 The following circuit description applies to ASR and KSR sets only.

SECTION 574-100-103TC

2.84 The path for the 8th pulse, through the keyboard contact block on a nonparity keyboard, are make contacts which close so that the 8th pulse is marking for all characters.

2.85 The path for the 8th pulse, through the contact block on parity keyboards, is from KP(2) to KS(1) as follows:

(a) The 8th pulse is spacing for all characters when the sum of the marking pulses in bits 1 through 7 is even. No path is provided between KP(2) and KS(1) since the 8th pulse make contacts connected to KP-J and the shift make contacts connected to KS-C are open.

(b) The 8th pulse is marking for all characters when the sum of the marking pulses in bits 1 through 7 is odd. A path is provided from KP(2) through the 8th pulse make contacts, KP-J, KP-L, KS-D, the shift break contacts, KS(2), KS-A, and the control break contacts to KS(1).

2.86 When the CTRL (control) key is depressed along with a key for a letter character, the control break contacts open so that the 7th pulse is now spacing. This action makes the 6th and 7th pulses alike resulting in a control or nonprint character.

2.87 On a parity keyboard, whenever the SHIFT key is depressed to invert the 5th pulse, or the CTRL key is depressed to change the 7th pulse from marking to spacing, the 8th pulse must be changed to keep the sum of the marking pulses even. This is accomplished in the following manner:

(a) When the SHIFT key is depressed and the 8th pulse is normally marking, the opening of the shift break contacts connected to KS-D changes the 8th pulse to spacing.

(b) When the SHIFT key is depressed and the 8th pulse is normally spacing, the closing of the shift make contacts connected to KS(2) change the 8th pulse to marking. The circuit path is traced from KP(2) through the break contacts KP-K, KP-R, KS-C, shift make contacts, KS(2), KS-A and the control break contacts to KS(1).

(c) When the CTRL (control) key is depressed and the 8th pulse is normally marking, the opening of the control break contacts change the 8th pulse to spacing.

(d) When the CTRL key is depressed and the 8th pulse is normally spacing, the closing of the control break contacts connected to KS(2) changes the 8th pulse to marking.

C. Control and Shift

2.88 To obtain certain code combinations, the CTRL (control) and shift keys are depressed in addition to some other key. When this is done, the 5th pulse is inverted and the 7th pulse is spacing, but the 8th pulse does not change.

2.89 With the 8th pulse normally marking, the circuit goes from KS(2) through the make contacts, KP-J, KP-L, the shift make contacts, KP(6), KS-B, and the control make contacts to KS(1).

2.90 With the 8th pulse normally spacing, the circuit will be broken since the shift break contacts connected to KP-R and the 8th pulse make contacts are open. The path through KP-R, KS-C, the shift make contacts, KS(2), and KS-A is broken since the control break contacts are open.

SELECTOR MAGNET DRIVER CIRCUIT

2.91 The selector magnet driver is a two-stage triggering regenerative amplifier or flip-flop, used to drive the selector magnets of the typing unit. The input, 0.020 or 0.060 ampere signal line current, is used to switch the selector magnets 0.500 ampere output current to full on or off, without intermediate levels. This provides a switching operation similar to that obtained with relays.

2.92 Zener diode ZD1 provides a reference voltage of 4.7 volts. This voltage is maintained regardless of varying values of current through ZD1 or with variations in external voltages. Therefore, the junction of CR4 and ZD1 is always -24.7 v dc. (Current flows from -20 v dc through ZD1, CR4 and R8, and through the parallel path of R2 to -40 v dc.)

2.93 The frequency modulated space and mark signals are demodulated and amplified in the data set. Refer to the appropriate sections for a description of the data set discriminator and dc amplifier circuits.

2.94 When spacing pulses are generated, no current flow through the emitter and collector of Q3A (in the 101C data set) or 6Q10 (in the 105A data set). A current of 10 ma flows from -20 v dc through resistor R3, varistor CR5 and the emitter-base path of Q1, and through R1 to -24.7 v dc at the junction of CR4 and ZD1. (When the signal line current is 0.060 ampere and switching at 0.030 ampere is desired, R1 is 135 ohms.) Transistor Q1 is on (base is more negative than emitter) and current flows through its emitter and collector. This puts the base of Q2 at about -20 v dc. The Q2 emitter, because of bias resistor R6, is at about -20.5 v dc. Because the base of Q2 is positive with respect to the emitter, Q2 is off and no current flows through the selector magnet coils.

2.95 When marking pulses are generated, a 0.020 ampere signal current flows from ground at the emitter of transistor Q3A (in the 101C data set) or 6Q10 (in the 105A data set) through the emitter-collector path, resistor R30N or 6R44 in the data set and through resistor R10. (Resistor R10 is strapped out for operation with 0.060 ampere signal current.

2.96 The current through R10 then divides with 0.010 ampere going through resistor R1, diode CR4 and resistor R8, and through the parallel path of resistor R2 to -40 v dc. The base of Q1 is at a potential of about -19.5 v dc while the emitter is at -20 v dc. With the base more positive than its emitter, Q1 is off and has no collector current. The voltage drop across diode CR4 is about 0.5 volt, making the potential at the base of Q2 about -25.2 v dc. With the base more negative than its emitter, Q2 turns on, and its emitter-collector current flows through the selector magnet coils.

2.97 When Q2 conducts, its base is held at about -25.2 v dc by ZD1 and CR4. The current through R3, R4, and R5 is about 0.5 ampere, most of which flows through the selector magnet coils and the collector. Rheostat R3, is adjusted for a selector magnet current of 0.5 ampere. This current is constant because reference diode ZD1 is not affected by voltage variations.

2.98 Feedback in the emitter circuits of Q1 and Q2 is used to provide the circuit transitions with a "snap action." When Q2 turns on, the current through feedback resistor R3 rises rapidly and the voltage across it increases. This drives the emitter of Q1 more negative. Therefore, when Q1 turns off it is because of the increasing collector current of Q2.

2.99 Similarly, when Q2 turns off, the current through R3 decreases and the voltage across it decreases, making the emitter of Q1 more positive. In this way Q1 is driven on when Q2 turns off.

2.100 The transient developed in the collector of Q2 when it is turned off is suppressed by the network consisting of CR3, R9, and C1. Diode CR6, added to recently manufactured circuits, prevents destruction of transistor Q1 by accidental shorting of the case (collector) of Q2 to frame ground.

LOCAL AND MOTOR CONTROL CIRCUITS

2.101 The CY (copy) relay (5F3), in the 101C data set, is operated by closure of the CON (connect) relay contacts when the set connects, or by closure of the LCL (local) key contacts 27 and 28. The CY relay releases when the set goes out of the local mode, or when the S (send space) contacts operate on a disconnect.

2.102 The CY relay (5F2), in the 105A data set, is operated by closure of the CR (connect - normally released) contacts when the set connects, or by closure

of the LCL (local) key contacts 27 and 28. The CY relay releases when the set goes out of the local mode or when the SR (send space - normally released) contacts operate on a disconnect.

2.103 In the local mode, the circuit through the CV relay is completed to ground by LCL contacts 25 and 26. Local contacts 29 and 30 close to light the LCL (local) lamp. Using a 101C data set in an originating station, the circuit is completed through the CV relay and OR6 make contacts to ground. If the 101C data set is used in an answering station, the circuit is completed through the AN11 make and OR6 break contacts to ground.

2.104 In a station that uses a 105A data set, the circuit is completed through the CV relay and OH make contacts to ground. This circuit is in effect when a station goes off-hook in either the originate or the answer mode.

READER CONTROL CIRCUITS

2.105 The following circuits are applicable to ASR sets only.

2.106 Using a manual reader, the circuit path goes from 48 v ac through the TD trip magnet, RS break contacts, START switch make contacts, RB or RR break contacts, and TD stop break contacts (on sprocket feed printers) to ground.

Originate Mode

2.107 Using a 101C data set, the circuit goes through CN-32 and OR6 make contacts to ground. If a 105A data set is used, the circuit path goes through CN-32 and OH make contacts to ground.

Answer Mode

2.108 Using a 101C data set, the circuit path goes through CN-32, AN11 make contacts, and OR6 break contacts to ground. If a 105A set is used, the circuit goes through CN-32 and OH make contacts to ground.

Local Mode

2.109 In the local mode, the circuit path goes through LCL contacts 25 and 26 to ground using either a 101C or 105A data set.

2.110 With the switch on the reader in the START position, the start contacts close and the TD trip magnet is put into operation. If the reader runs out of tape or if the tape becomes tight, the start contacts will open. This will cause the trip magnet to release and stop the operation of the distributor and reader. When the tape slackens, the contacts will close and normal operation resumes.

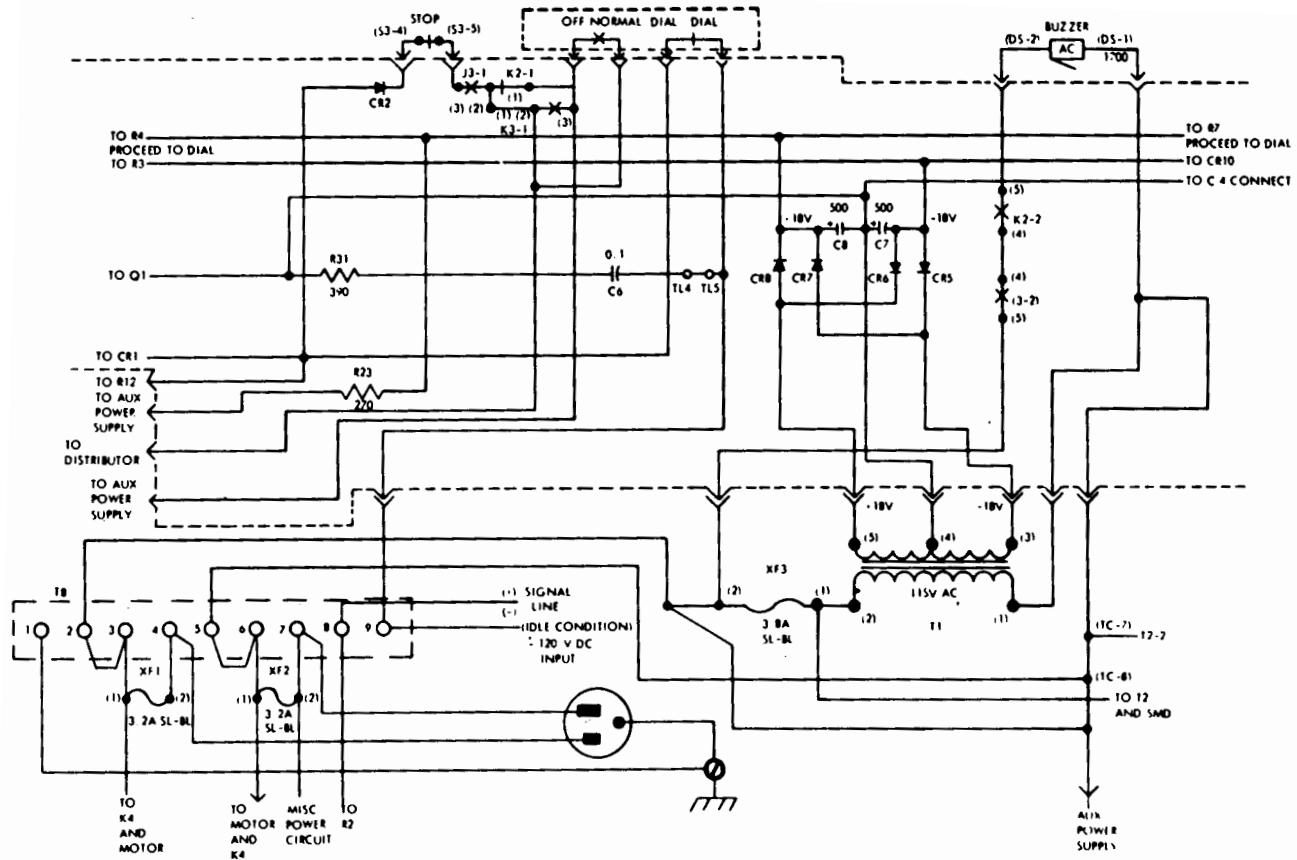

Figure 1 - Power Supply Circuit

0.02 second delay in the connect circuit. The network consisting of R31 and C6 found in the 240 volt signal line, acts as an arc suppressor to protect its associated contacts. This network may be removed from the signal line by removing the strap between terminals TL4 and TL5. Additional network components may be added to these terminals, if required.

A. Proceed-to-Dial Circuit

3.06 The proceed-to-dial circuit (Figure 2), consists of a binary with a line input amplifier. The amplifier consists of transistor Q1 and its associated components, and the binary consists of transistors Q2 and Q3 along with their associated components. The amplifier is connected to the binary through a low-pass filter delay network (R5 and C1) which suppresses signal line noise. The input to the binary, coming from the filter network and passing through R6, will turn on the proceed-to-dial circuit. Control inputs through R15 and the stop pushbutton contacts 1 and 2, are used to turn off the circuit. Operation of the transistors in the proceed-to-dial circuit is as follows:

- (a) When transistor Q2 is in conduction, its collector is very near a neutral potential. Current will flow through Q2, R11, stop pushbutton contacts 1 and 2, and R27. Current will also flow from +18 volts through R8 and CR9 to the collector of Q2. The base of Q3 will be held at +0.8 volts with respect to the collector of Q2 due to the current flow of CR9. The base of Q3 will therefore, be slightly positive with respect to neutral, and Q3 will be turned off. With Q3 off, its collector will be negative and Q2 will be held in conduction. This is accomplished by applying current to the base of Q2 supplied through the low-pass filter made up of R9, R10, and C3.
- (b) When transistor Q3 is in conduction, the proceed-to-dial circuit will be on and the collector of Q3 will be very near neutral. Current will flow through Q3, K1, the dial lamp, and R27. Since the collector of Q3 is near neutral, current flow through R7, R9, and R10 will produce a positive potential at the base of Q2. This positive potential will hold Q2 off. With Q2 held off, base current for Q3 will flow through CR9, R11, stop pushbutton contacts 1 and 2, and R27. This flow of current will hold Q3 in conduction.

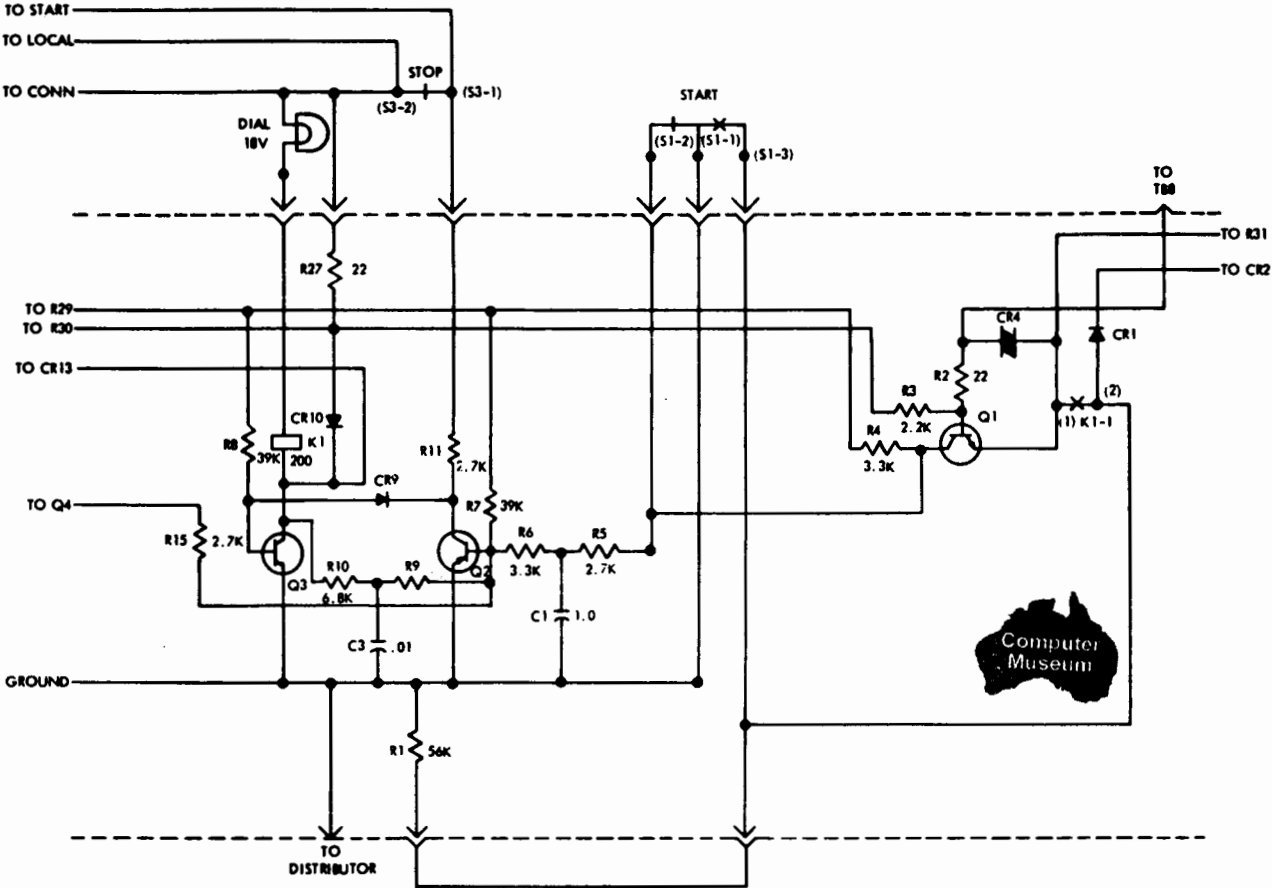

Figure 2 - Proceed-to-Dial Circuit

(c) If an input current in excess of 0.009 ampere flows from TB-8 across CR4 to neutral, a positive potential of 0.8 volts will be developed across CR4. This positive potential will hold Q1 in conduction and its collector near neutral. The neutral condition has no effect upon the base of Q2 because of the isolation provided by R5 and R6. If the input current falls below 0.009 ampere, a negative potential of 0.8 volts is developed across CR4 due to current flow through R3, R2, and CR4. This potential will turn off Q1 and its collector becomes positive. Current now flows through R4 and R5 to charge C1 towards a +18 volts. When a sufficient voltage is developed across C1, the base of Q2 will be back-biased through R6. Transistor Q2 turns off and Q3 turns on placing the proceed-to-dial circuit in the on condition. Back-bias to the base of Q2 is supplied by the voltage divider R7, R9, and R10 so that the positive potential across R6 is no longer required to hold Q2 off. If more than 0.009 ampere begins to flow across CR4 again, Q1 will turn on, and its collector will go to neutral, but this will have no effect on the base of Q2.

(d) If a negative signal is applied to the side of R15 opposite the base of Q2, enough current will flow to forward-bias the base of Q2 and cause it to conduct. Q3 will turn off and supply sufficient base current through R9 and R10 to hold Q2 in conduction. The negative signal on R15 can now be removed, and Q2 will remain in conduction.

(e) With the proceed-to-dial circuit on, Q3 will be in conduction. Base current for Q3 will flow through R11 and CR9. Depressing the STOP pushbutton causes contacts 1 and 2 to open breaking the current path. Transistor Q3 will then turn off and Q2 will turn on. There will be no collector current flowing in Q2; therefore, the collector will be near neutral holding Q3 off. When the STOP pushbutton is released, collector will flow in Q2 and the proceed-to-dial circuit will turn off.

B. Connect Circuit

3.07 The connect circuit (Figure 3) consists of a binary (Q4 and Q6) of which one side is driven by emitter follower Q5. The only control input to this circuit is by the

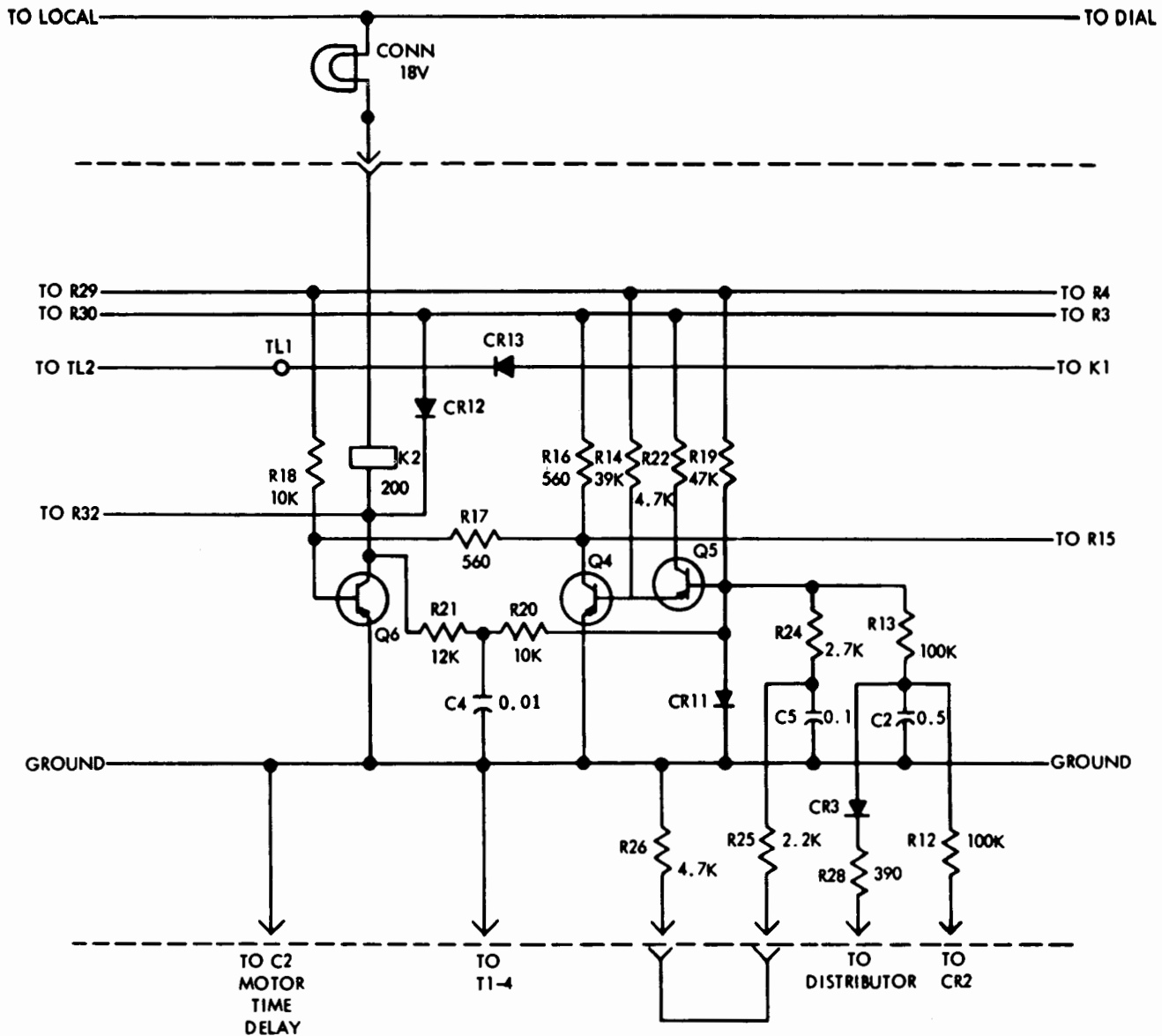

Figure 3 - Connect Circuit

signal line through R12 and R13. A signal delay of approximately 0.02 seconds is provided by the low-pass filter network consisting of C2 and R12. A single passive control, consisting of R28 and CR3, is used for low-paper conditions.

(a) Transistor Q5 controls the base of Q4. When transistor Q4 is in conduction, its collector is very near a neutral potential. A voltage divider consisting of R17 and R18 hold the base of Q6 positive so that Q6 is off. This will make the collector of Q6 go negative and also make the base of Q5 go negative by the current path through R20 and R21. Since Q5 is an emitter follower, its emitter will be held at the same potential as its base. With its emitter at a negative potential, Q4 will be held on.

(b) When the connect circuit is on, Q6 will be in conduction and its collector will be near a neutral potential. The voltage divider R19, R20, and R21 holds the base of Q5 and therefore the emitter, at a positive potential. With the emitter of Q5 at a positive potential, the base of Q4 will be reverse-biased, the transistor will be off, and its collector will go negative. The connect circuit will be held on by the base for Q6 that flows through R16 and R17.

(c) To control the connect circuit a high voltage must be developed at the junction of CR1 and CR2 (circuit card TP305689). This voltage will be approximately +200 volts. If a +200 volt signal is applied at this point, the base of Q5 will be biased positive. Q4 will

turn off and Q6 will turn on. If a -200 volt signal is applied, the base of Q5 will be biased negative, Q4 will turn on and Q6 will turn off. An input signal at or near a neutral potential will have no effect upon the connect circuit, and it will remain in its prior state.

(d) The base of Q5 is protected against excessively high voltages by transistor operation or by CR11. If a -200 volt signal is present, the voltage on the base of Q5 will go in a negative direction and force its emitter to follow. When the emitter of Q5 becomes negative with respect to ground, Q4 will turn on. With Q4 in conduction, the potential on its base will be close to the emitter. Therefore, the base cannot go more negative than -0.4 volts. This action will hold the base voltage of Q4 to within -0.4 volts of its emitter. Therefore, the base voltage of Q5 cannot become more negative than -0.8 volts. If a +200 volt signal is present at the input, the base of Q5 will start to become positive. The diode CR11 is forward-biased to positive base voltages. It will, therefore, limit the base voltage of Q5 to +0.8 volts. Therefore, under the severest input conditions, a voltage swing of more than +0.8 volts is not expected.

(e) Resistors R24, R25, R26 and capacitor C5 are used where a polar converter is employed. They are shown all connected together and have no effect upon the operation of this circuit.

C. Local Circuit

3.08 The local circuit (Figure 4), consists of a binary and a unijunction transistor timer. The binary operation of Q8 and Q9 is the same as that described in the proceed-to-dial circuit. Four input controls are available for use with the local circuit.

(a) Operation of the LOCAL pushbutton allows transistor Q9 to go into conduction and also turn the local circuit on. When contacts 1 and 2 are closed, base current will be supplied to Q9 through R37 and R38 causing Q9 to turn on and Q8 to turn off. If the anode of either CR13 and CR14 is neutral, the current flowing through R38 will flow through one of these diodes and not reach the base of Q9. These two diodes allow the local circuit to be turned on only when the proceed-to-dial and the connect circuits are off.

(b) The local circuit can be turned off by depressing either the START or the STOP pushbutton. When the local circuit is on, the base current of Q9 flows through start contacts 4 and 5 and stop contacts 1 and 2. Since the contacts of the two pushbuttons are in series, operating either of them will turn Q9 off. The output of unijunction transistor Q7, will also turn off the local circuit as it is basically a breakdown device.

(c) If the voltage on C9 is more negative than approximately -8 volts, the resistance of the junction between the lead connected to C9 and the lead connected to R35 is high. When the voltage on C9 becomes more positive than -8 volts, the resistance of this junction will become very low, and C9 will recharge through R35. The increase in current flowing through R35, while recharging C9, will cause an increase in the voltage drop R35. The positive pulse is coupled through C10 and CR17 to the base of Q9 and causes it to turn off and Q8 to turn on. The local circuit is then off. As capacitor C9 is recharged, the resistance of the junction again becomes high.

(d) Capacitor C9 is discharged toward neutral or held at about -18 volts through R32 and R33. If the input to R32 is negative (connect circuit off), C9 will be held at -18 volts. If the input to R32 is near neutral (connect circuit on), capacitor C9 will discharge through R32 and R33 toward neutral. At the end of a 2.3 second interval, the voltage on C9 will be approximately -8 volts and the unijunction will break down and turn the local circuit off as described above.

MOTOR DELAY TIMER CIRCUIT

3.09 The motor delay timer circuit (Figure 5), provides the means to delay motor turn-off in the teletypewriter. This allows the teletypewriter to complete its printing cycle and come to rest before the motor begins to stop. This circuit, along with the selector magnet driver circuit, are mounted on the same circuit card but are electronically independent of each other. The circuit is designed to drive a motor control relay connected between points 3 and 5 and is operated when either the connect or local circuit is on.

3.10 The motor delay timer consists of a regenerative switch (Q3 and Q4) and an output driver (Q2). The input to the motor delay timer is from the collector of Q9 through diode CR16 or from the collector of Q6 through diode CR15 in the local and connect circuits of the local-remote control circuit. The diodes provide insulation between the input of the motor delay timer and the transistors of the local-remote control for negative signals. When the input of the motor delay timer at point 2 is grounded, the output driver will turn on immediately. When the input signal is removed, the output driver will remain in conduction for 0.55 seconds while holding the motor relay operated long enough to allow the teletypewriter to complete its printer cycle before turning off the motor.

3.11 When a negative input signal is applied to point 2, base current to Q3 will flow through R13, R15, and R14. Q4 will be held in conduction by the base current flowing through R12 and R16. The collector of Q3 will be close to -1.6 volts. The voltage divider R12 and R16, will hold the base of Q2 positive and therefore Q2 will be cut off.

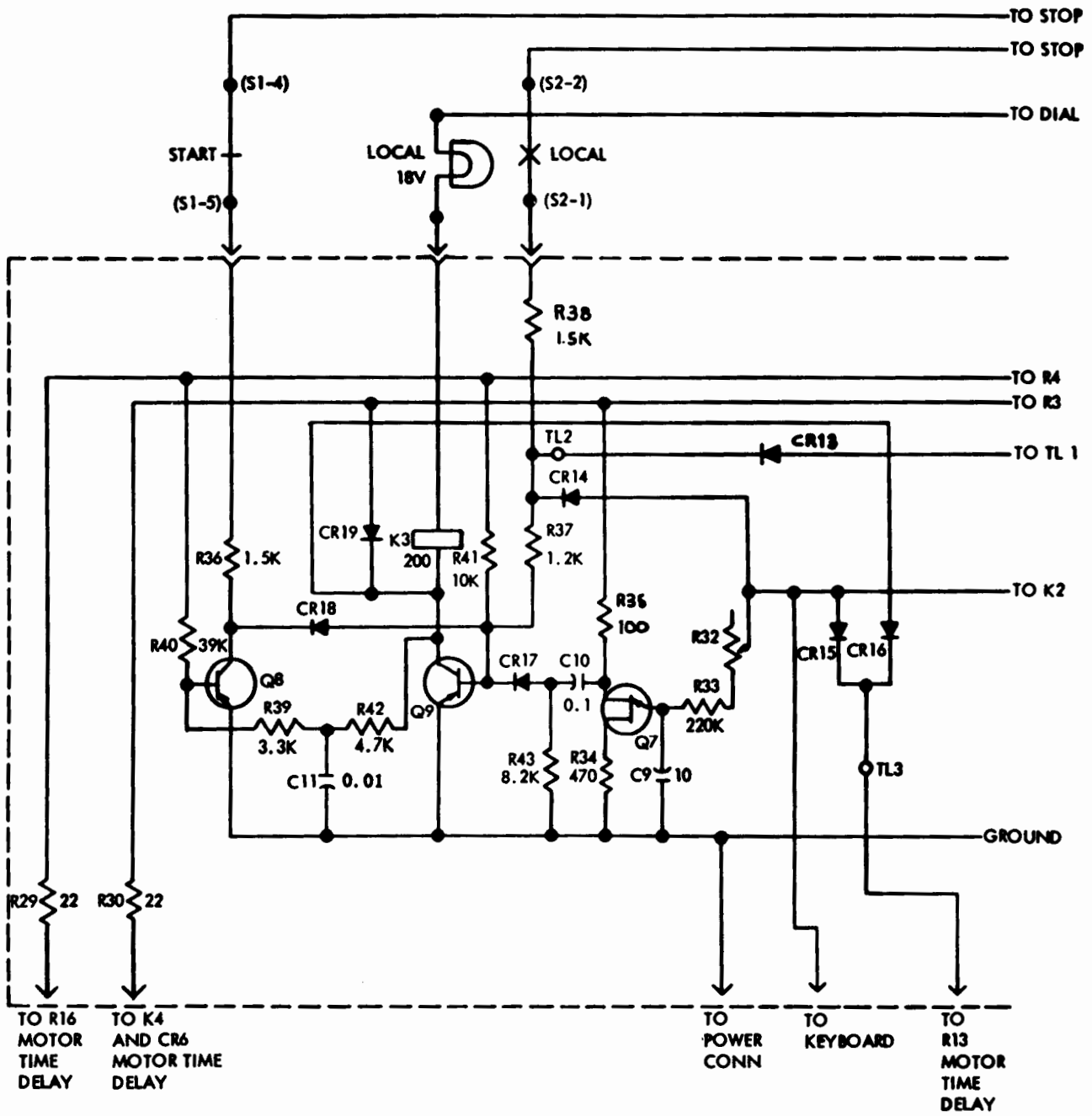

Figure 4 - Local Circuit

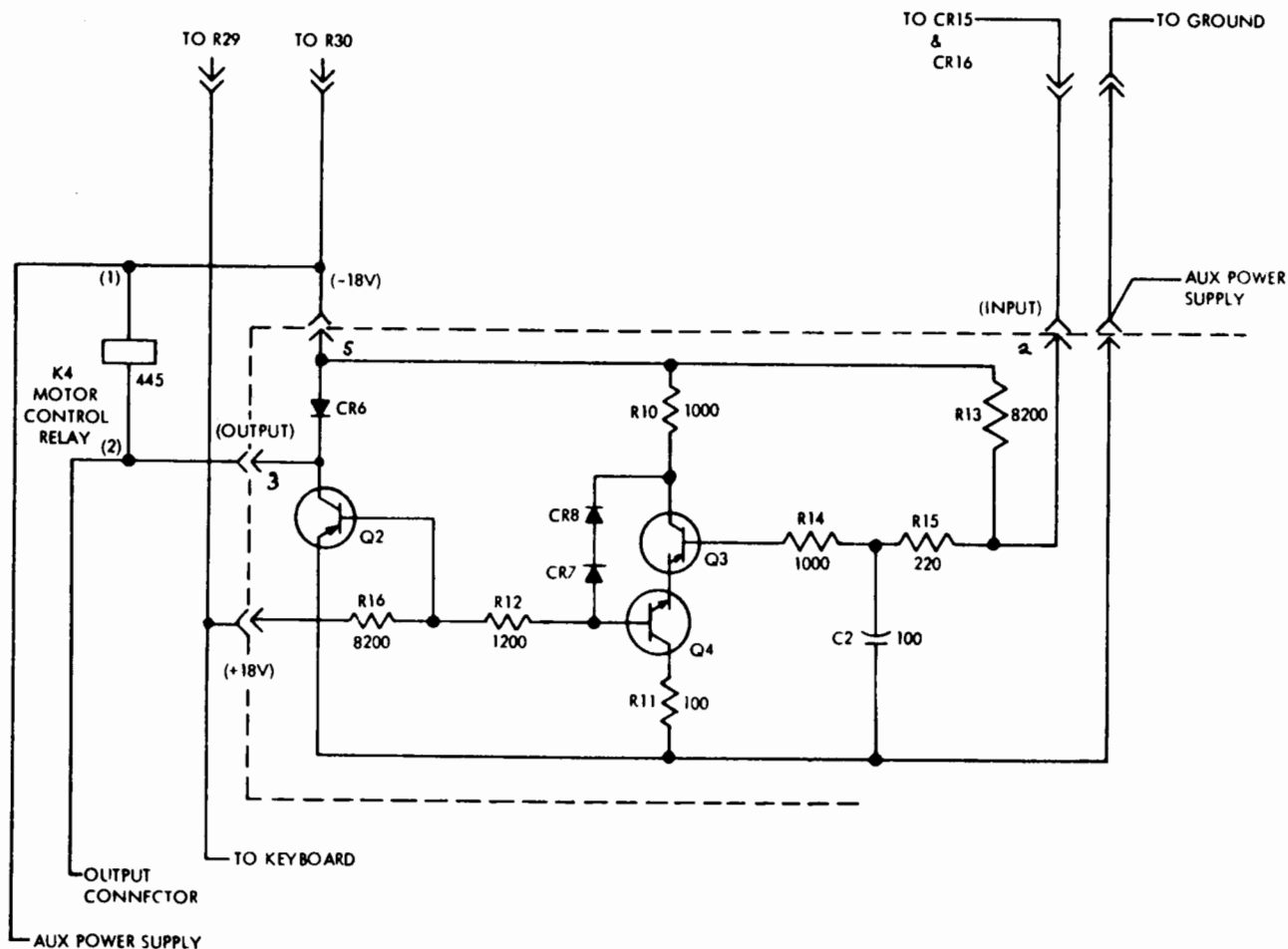

Figure 5 - Motor Delay Timer Circuit

3.12 If ground is now applied to the input, the base of Q3 will approach ground and become reverse-biased. This will turn Q3 off. The collector of Q3 will now be at a potential of -10 volts. This voltage will cause the voltage at the base and emitter of Q4 to be at a potential of -8.5 volts. The emitter of Q3 will be held at -8.5 volts by the emitter of Q4. This will hold Q3 off. The -10 volt potential at the collector of Q3 will cause base current to flow to Q2 through CR7, CR8, and R12. Q2 will then go into conduction, and operate the external motor control relay.

3.13 If the ground input is now removed, current will flow through R13 and R15 and charge C2 toward -18 volts. After about 0.55 seconds the voltage on C2 will reach -8.5 volts and Q3 will go into conduction with its collector going less negative. This causes the base of Q4 and, therefore, the emitter of Q3 and Q4, to become less negative. This process will continue until both Q3 and Q4 are saturated. C2 will then discharge through R11 and the base of Q3 to ground. Base current to hold Q3 in conduction is supplied through R13, R15, and R14.

3.14 At 25 degrees C, with a 390 load, the delay of the motor timer is from 0.475 second to 0.675 second when the supply voltages are within 3 percent of their nominal values.

SELECTOR MAGNET DRIVER CIRCUIT

3.15 The selector magnet driver circuit (Figure 6), combined with an external power transformer, and a filter capacitor, provides 0.500 ampere current for driving the selector magnet from a telegraph signal source of appropriate input line current. The input signals are applied through terminals 6 and 11, with R1 determining the switching level.

3.16 For a mark input, a positive current is applied to terminal 11. This will provide a positive bias to the base of transistor Q1 that overcomes the normal negative bias supplied through R1 and stabilized by zener diode ZD1. Q1 will turn off as the increasing positive current reaches one-half of its final value. The collector of Q1 then goes

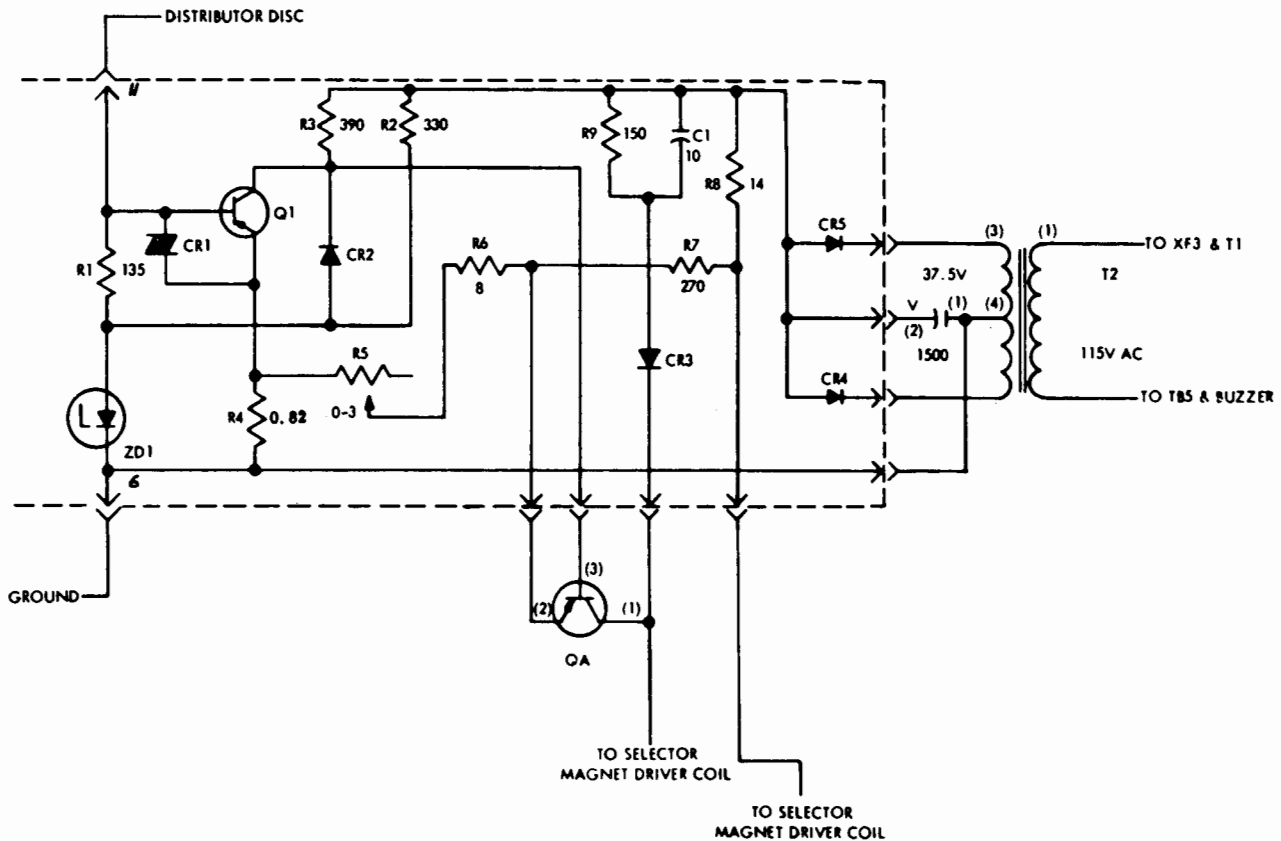

Figure 6 - Selector Magnet Driver Circuit

negative and this negative potential is applied to the base of QA and turns QA on. R4 will provide emitter bias to Q1, and supplies a regenerative action to the transistor.

3.17 The selector magnet is connected between the collector of QA and the junction of R7 and R8, and supplies the load for QA. On marks, the current rises to 0.500 ampere and energizes the selector magnet. On spaces, the positive input bias decreases, and Q1 is turned on at the half-line current point by negative bias through R1. The collector of Q1 rises towards a zero potential, applying reverse-bias to QA, turning off QA, and de-energizing the selector magnet. The selector magnet opposes the change in current, and it applies a transient potential to the collector of QA. CR3 will now conduct and pass the transient potential to C1 and R5 which limits the potential to a value well under the breakdown voltage QA while selector magnet energy is being dissipated.

NEUTRAL SIGNALING

A. Circuit Interconnections

3.18 The block diagram for the circuit interconnections is shown in Figure 7.

Proceed-to-Dial

3.19 In order to turn on the proceed-to-dial circuit, two conditions must be satisfied: The START push-button must be depressed and the proper line signal must be received from the exchange. The START pushbutton presents the proper signal to the exchange so that the request to dial is recognized. It also protects the circuit from an open line and long line breaks such as those generated when dialing.

3.20 The proceed-to-dial circuit can be turned off in two ways: By the depression of the STOP push-button or by the operation of the connect circuit. Local control is provided by the STOP pushbutton while the connect circuit provides automatic control initiated by the exchange.

3.21 The connect circuit is controlled only by the line and, therefore, has only one input which comes from line sensing and control.

Local Circuit

3.22 To turn on the local circuit, the following conditions must be satisfied:

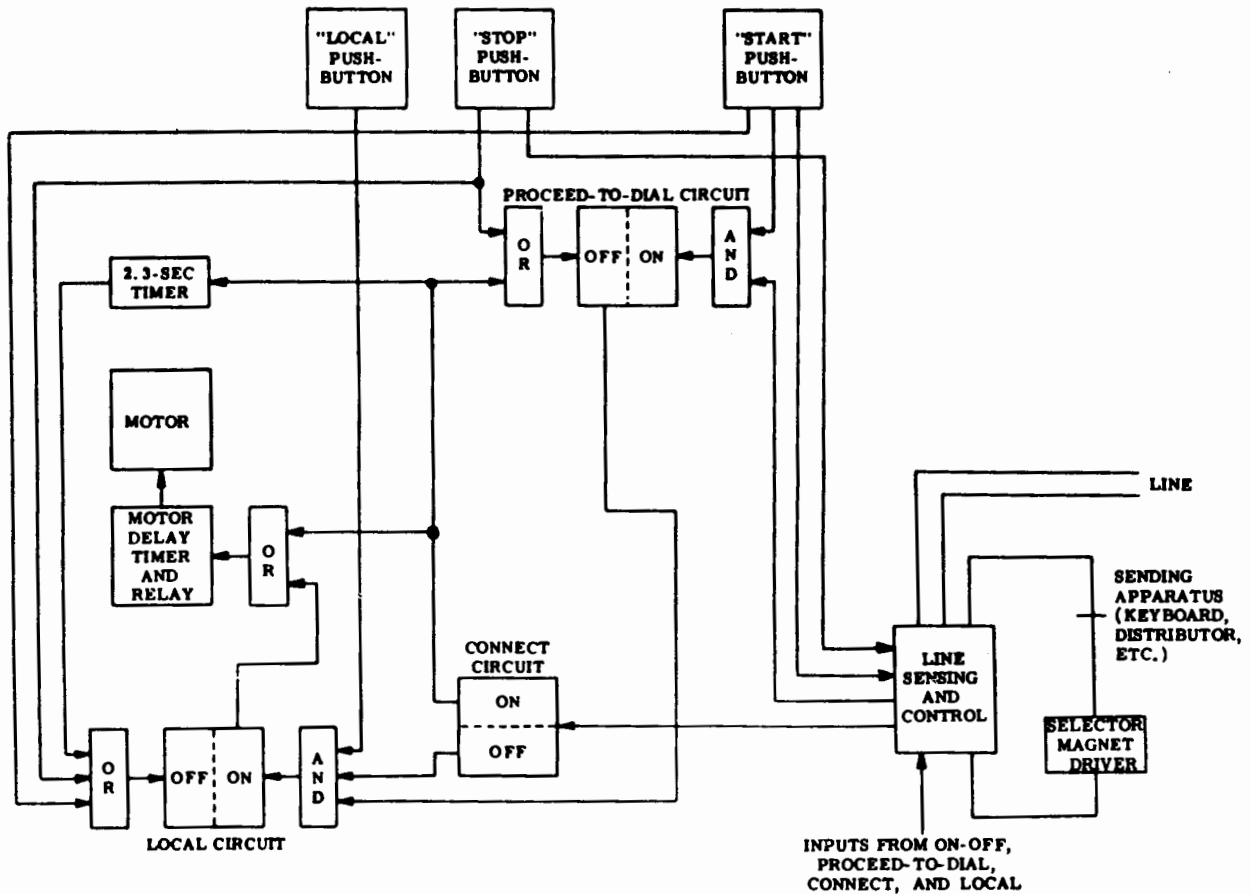

Figure 7 - Circuit Interconnections

(a) The proceed-to-dial and the connect circuits must be off, and the LOCAL pushbutton must be depressed.

(b) The input of both the proceed-to-dial and the connect circuit protect against the accidental operation of the local circuit which would otherwise cause an automatic disconnect.

3.23 The local circuit is turned off by depressing the STOP pushbutton, the START pushbutton, or the 2.3-second timer. The START and STOP pushbuttons provide local control of the circuit, while the 2.3-second timer provides the automatic control. The timer is controlled by the connect circuit which is, in turn, controlled by the line. The timer will continue to oscillate as long as the connect circuit is on although only the first timing pulse is required to turn off the local circuit.

3.24 Each of the circuits mentioned has an input to the line sensing and control. The inputs are in the form of relay contacts which switch the line through the proper internal path in the local and remote control assembly. When

either the connect or local circuit is on, a motor control relay is operated. The contacts of the relay are used to turn on the motor of the associated typing unit.

B. Idle Line Conditions

3.25 The schematic diagram of the local-remote control circuit (Figure 8) shows the current flow during the idle line condition. In this state, all relays and lamps are off. This requires that transistors Q3, Q6, and Q9 be off and that Q2, Q4, and Q8 be in conduction. The output transistor of the motor delay timer is off, and the selector magnet driver is marking.

3.26 The signal loop is a 240-volt source with 4000 ohms in series. In the idle condition the local-remote control offers 43,800 ohms of local resistance to the signal loop. The flow of loop current in this condition is shown in Figure 8. Current flows from TB8, the positive idle terminal, across CR4, through R1 and CR1 in parallel with the base emitter junction of Q4 and Q5, R13 and R12. From this point, current flows through the dial pulse contacts to terminal TB9.

R38 is held near neutral from the collector of Q6 through CR14. This will prevent operation of the local circuit.

3.33 Remote Connection: On an incoming call, the teletypewriter may be connected remotely while in the idle line or local conditions. The loop path is shown in Figure 8 for both of these conditions. The incoming call causes the exchange to reverse the loop polarity. This causes the potential at the junction of CR1 and CR2 to change from -200 volts to approximately +200 volts. The potential causes the connect circuit to operate as described in 3.32

3.34 Low-Paper Circuit: If the paper in a teletypewriter has become low and the low-paper contacts operate, the junction of R12 and R13 will not be allowed to become positive. Q4 cannot be turned off, and a connection cannot be made. If low paper occurs during a call, the teletypewriter will remain in the connected state, since zero potential at the junction of R12 and R13 will not effect the connect circuit. A disconnect will occur in the normal manner, since CR3 will be reverse-biased to a negative potential at the junction of R12 and R13. If a call is initiated locally with a low-paper condition, the normal sequence of events will occur until a connection is attempted. When the exchange cannot connect, it will reverse the loop polarity, and the teletypewriter will return to the idle state.

E. Disconnect

3.35 Local Disconnect: Operation of the STOP pushbutton while in the connect condition opens contacts 4 and 5 which are in series with the loop, and breaks the loop. When the exchange recognizes the break, it reverses the loop polarity. The reverse polarity is blocked by CR2, and current flows through CR1 along the path shown in Figure 8. At point A a -200 volt potential is developed due to the current flow described in 3.26 through 3.28. This potential causes the connect circuit to turn off and the teletypewriter stops running open. The input to the motor delay timer becomes negative, and the timer will time out. After 0.55 second the motor control relay releases, and the motor will turn off.

3.36 Remote Disconnect: The operation of the circuits and the loop paths are the same as those described in 3.33. The STOP pushbutton is not operated locally, but the signal conditions appear identical to the local-remote control.

F. Local Off-Line Operation

3.37 When the teletypewriter is in the idle line condition, depressing the LOCAL pushbutton will cause the local circuit to turn on. If the control is in the proceed-to-dial or connect conditions, either CR13 or CR14 will prevent operation of the local circuit. When the local circuit does operate, the LOCAL lamp will light. K3 relay

located in the keyboard selector magnet driver loop. Current in this loop will then flow through R23, K3 relay contacts 2 and 3, the keyboard, and the selector magnet driver to neutral. CR16 will be forward-biased causing the output transistor of the motor delay timer to turn on. The motor control relay will operate and the motor will start. The teletypewriter is now ready for off line operation. To return to the idle position, the STOP pushbutton should be depressed. STOP pushbutton contacts 1 and 2 open and turn off the local circuit. A call may be initiated in the usual manner. When the START pushbutton is depressed, its contacts 4 and 5 open and turn off the local circuit the same way as if the STOP pushbutton were used.

(a) If an incoming call is received while the teletypewriter is in the local condition, the action of the circuit is the same as that described in 3.30 through 3.32. The K2 relay operates to shunt the line through the keyboard distributor and selector magnet driver, but this operation cannot be accomplished since the K3 relay contacts 2 and 3 have shorted the K2 relay contacts 1 and 2 out of the circuit. Operation of the K3 relay contacts 4 and 5 will complete the 115 v ac circuit to the buzzer causing it to sound.

(b) With the connect circuit on, the collector of Q6 will be near neutral. This causes the timer to start. At the end of a 2.3 second period, a positive pulse from the timer is coupled to the base of Q9 through C10 and CR17. This pulse will cause the local circuit to turn off. The LOCAL lamp will go out and K3 will release. The K3 contacts 1 and 2 will short the signal loop through the keyboard distributor and selector. The K3 relay contacts 4 and 5 will open and the buzzer will turn off. The teletypewriter is now in the connect condition.

POLAR ADAPTER

A. General

3.38 The following description is based upon schematic wiring diagram 5923WD.

3.39 The polar adapter converts the types of signals received from the receiving leg and the teletypewriter into those usable by the circuitry and the sending leg. Some of the functions of the relay contacts are modified by the polar adapter, but they serve the same general purpose. The outward operations of the call control unit, with the polar adapter attached, are identical to those of the call control unit alone.

3.40 The polar adapter consists electrically of four basic parts. These parts are:

(a) Receiving polar relay: This relay converts the received signals into those usable by the circuitry of the adapter and the call control unit.

(b) **Sending polar relay:** This relay converts the make-break signals generated by the distributor into transmitted line signals.

(c) **Connect control timer:** This circuit is made up of four basic parts and differentiates between control and information signals.

(d) **Current amplifier:** This circuit amplifies the signals of the receiving polar relay to control the selector magnet driver.

3.41 The polar adapter operates on a 3-wire basis. Two of these wires are the sending and receiving legs. The third wire is an earth return for these two legs. The polar adapter will, therefore, not operate unless earth ground is supplied. The chassis of the polar adapter is grounded to the power supply. When installed in the call control unit, electrical connection is made through the chassis contact to the third wire in the power plug. This third wire in the power cord must be connected to a suitable earth ground.

3.42 The sending and receiving polar relays are of the nonbridging mercury-wetted contact type. They are housed in metal cylinders with an 11-pin tube socket at their base. Because of the mercury in the relay capsule, they must be operated within 30 degrees of vertical to prevent shorting of the contacts.

(a) The coils of the polar relay are as follows:

Pins no. 2 and 11 - Drive coil
 Pins no. 3 and 10 - Drive coil
 Pins no. 5 and 9 - Bias coil
 Pins no. 6 and 8 - Bias coil
 Pins no. 1 and 7 - Contacts
 Pin no. 4 - Tongue

(b) In the polar adapter, contact no. 7 has been chosen as the spacing contact and contact no. 1 as the marking contact. To close contact no. 1 and the tongue, current must flow from either pins no. 2 to 11, 3 to 10, 9 to 5, or 8 to 6.

3.43 All polar relay contacts are protected by arc suppressors. These arc suppressors slow the rate of change of voltage across the mercury-wetted contacts of the polar relays. On the receiving polar relay the arc suppressors are made up of R32, R33, C5, and C6. On the sending polar relay they are made up of R43, R44, C7, and C8.

3.44 All voltage sources are isolated by at least 120 ohms. In the event of a momentary short, current through the polar relay contacts or the connectors is limited to 1 ampere or less. If a short is of long duration, the resistor will act like a fuse and open the shorted circuit. These resistors are R34, R36, R38, R41, and R42.

3.45 When polar signals are being transmitted by the sending polar relay, a noise suppressor is used in the sending leg. This suppressor consists of a "pi" filter and is made up of C11A, C11B, and R45. The filter rejects all high frequency components of the transmitted signal. It is not used when neutral signals are transmitted.

B. Receiving Polar Relay

3.46 This polar relay and its associated components convert incoming signals into those usable by the circuitry of the polar adapter and the call control unit.

3.47 Several types of input signals to this polar relay are possible. These modes of operation may be selected by appropriate strapping of the binding posts on the TP181607 printed card assembly. The various modes of operation are:

(a) Polar signals, battery supplied remotely. This is the normal mode of operation, and all polar adapters are supplied with strapping for this type of operation.

(b) Neutral signals, battery supplied by the polar adapter. In this condition, posts no. 3 and 4, 5 and 7, and 12 and 13 are strapped together.

(c) Neutral signals, battery supplied remotely (battery negative). In this condition, posts no. 5 and 12, 6 and 13, and 3 and 4 are strapped together.

(d) Neutral signals, battery supplied remotely (battery positive). In this condition, posts no. 3 and 4, 12 and 13, and 5 and 6 are strapped together.

3.48 With the wiring as described in 3.47, a spacing signal will cause the tongue (4) of the polar relay to rest on the space contact (7). With a marking signal, the tongue will rest on the mark contact (1). The tongue (4) of the polar relay is supplied with +120 volts through R34. It supplies this voltage to the selected contact, while the other contact has no potential applied. Both contacts have two outputs. One of these is a voltage or direct output, while the other is current output. The current output is through a diode and a resistor and will supply approximately 0.010 ampere to ground. The diode prevents reversed currents from flowing when the contact is not supplied with +120 volts from the tongue. The output diodes and resistors are CR11, CR12, R30, and R31.

3.49 The bias for this relay, when used in neutral operation, is 0.030 ampere and is supplied through R37 and strapped terminals no. 3 and 4. Operating current for neutral operation, when supplied locally, is supplied from -120 volts and is limited to 0.060 ampere by R46 and the signal line resistance.

C. Sending Polar Relay

3.50 This polar relay converts the neutral make-break signal generated by the distributor and the dial into those required on the sending leg. There are a variety of possible signal types that can be transmitted. These are:

- (a) Polar signals, battery supplied by the polar adapter. This is the normal mode of operation and all polar adapters are supplied with strapping for this type of operation.
- (b) Neutral signals, battery supplied by the polar adapter. In this condition, posts no. 10 and 11 are strapped together, and the straps between posts no. 8 and 9, 14 and 15, and 16 and 17 are cut.
- (c) Neutral signals, battery supplied remotely. In this condition posts no. 6 and 10 are strapped together, and straps between posts no. 8 and 9, 10 and 11, 14 and 15, and 16 and 17 are cut.
- (d) Since both the drive and bias windings are wired in series, both windings are supplied with the same amount of current. The input current of 0.021 ampere to the drive windings is supplied through R40 from +120 volts. The 0.021 ampere to the bias is supplied through R39 from +120 volts.

D. Connect Control Timer

3.51 This circuit consists of four basic parts on the TP181606 assembly. These are: a strobe pulse generator, two timing transmission gates, and binary.

3.52 The strobe pulse generator generates a 120 Hz square wave. This square wave and the outputs from the receiving polar relay are used as inputs to the two timing transmission gates. The outputs of these two gates are used to control the binary. The output of the binary, in turn, is used to control the connect circuit in the call control unit.

3.53 The strobe pulse generator is made up of Q1 and Q2 and associated components. It is controlled and caused to oscillate by alternating current from the power transformer of the call control unit. This 12.5-volt ac (18-volt peak) sine wave is rectified by CR1 and CR2 to form a negative 120 Hz wave. The base of Q1 is biased by R2 and R3 such that -3.9 volts is necessary at the junction of CR1 and CR2 to turn on Q1. When base current does flow to Q1, it will turn on, and its collector will become nearly ground. R4 and R5 form a voltage divider which back-biases the base of Q2 and holds it off. The voltage at the collector of Q2 will be set by a voltage divider made up of R8 and R9. This voltage is -9.1 volts. Feedback, through R6 from the collector of Q2 to the base of Q1, will help provide snap-action.

3.54 When the 120 Hz sine wave becomes more positive than -3.9 volts, base current to Q1 will cease to flow. The collector of Q1 will now have a potential of -5.7 volts. Current will now flow through R5 to the base of Q2 and cause the transistor to turn on. The collector of Q2 will now be very close to a neutral potential. This circuit will continue to oscillate as long as power is applied to the control unit transformer.

3.55 Two, 1-percent tolerance resistors (R8 and R9) in the collector of Q2, set the voltage at that point at -9.1 volts. This voltage level is important in controlling the binary and setting the proper time delay intervals in the timing gates. The square wave generated at the collector of Q2 will be ground for approximately 0.0013 second and -9.1 volts for approximately 0.007 second.

3.56 When spacing signal is present on the receiving leg, +120 volts is applied to contact no. 7 and no voltage is applied to contact no. 1 of the receiving polar relay. No voltage will appear across R28, and the voltage at the junction of R28 and R26 is set by current flow through CR10 and R26. This voltage will be approximately -60 volts. CR8 will conduct and the voltage across C3 and at the anode of CR5 will be held at -60 volts. If Q4 is in conduction, its base will be nearly ground, and CR5 will be back-biased by 60 volts.

3.57 The 9.1 volt strobe pulse introduced at C1 will cause the voltage at the anode of CR5 to rise to -50.9 volts. The negative pulse, that follows in 0.0013 second will lower it to -60 volts. The net result of these strobe pulses upon the voltage on C3 is, therefore, zero, and CR5 is not forward-biased at this time.

3.58 When a marking signal appears on the receiving leg, a positive potential of 120 is applied to one side of R28 through the marking contacts of the receiving polar relay. The voltage divider of R26 and R28 will have a +22 volt potential at its junction and reverse-bias CR8. This action will isolate C3 from R26 and R28 and it will begin to discharge through R20 from a -60 volt potential toward ground. The anode voltage of CR5 will respond to the discharging, reducing its reverse-bias condition. After approximately 0.08 second the voltage on C3, and therefore the anode of CR5, will have risen to -9.1 volts. The next strobe pulse to appear at C1 will cause CR5 to become forward-biased, and part of the pulse will appear at the base of Q4.

3.59 The gate just described is the connect timing gate and produces a signal delay of approximately 0.08 second. The disconnect timing gate operates in a similar manner. The input to R27 is from the spacing contact. When mark appears on the receiving leg, R25 and CR9 hold the voltage on C4 at -60 volts. When a spacing signal appears, CR7 will be back-biased, and C4 will discharge through R19

from -60 volts toward ground. In approximately 1.3 seconds the voltage across C4, and therefore at the anode of CR4, will become more positive than -9.1 volts. The next strobe pulse introduced across C2 will cause CR4 to be forward-biased, and part of the strobe pulse will appear at the base of Q3.

3.60 C3 will recharge to -60 volts from -9.1 volts in 0.004 second. C4 will recharge in 0.01 second. Both of these recharge times are less than one code element length and can be considered instantaneous.

3.61 The outputs of the transmission gates control the binary which is made up of Q3 and Q4 and associated components. The operation of this binary is similar to that of the binaries in the call control unit. The control of the binary by the transmission gates is the same as that of the 2.3-second timer controlling the local circuit in the call control unit. A positive pulse at the base of Q4, through CR5, will turn off Q4 and turn on Q3. The collector of Q3 will then be near ground. Current will flow through R35 and through ZD1 to the collector of Q3. The cathode of

ZD1 will be +9.1 volts with respect to its anode, so that the voltage at the cathode will be +9.1 volts. This point is the output to the connect circuit of the call control unit.

3.62 A positive pulse at the base of Q3 through CR4 will turn off Q3 and turn on Q4. The collector of Q3 will go negative. Current flow through CR6 and R23 will hold this voltage to -18 volts. Current flow through R35 and ZD1 will hold the voltage at the cathode of ZD1 to +9.1 volts of -18 volts. The output will then be -8.9 volts. A negative output (Q3 off) will hold the connect circuit of the call control unit off, and a positive output (Q3 on) will hold the connect circuit on.

E. Current Amplifier

3.63 This circuit is made up of Q5 and associated components on the TP181606 assembly. Base current to this amplifier is supplied through CR12 and R31 from the marking contact of the receiving polar relay.

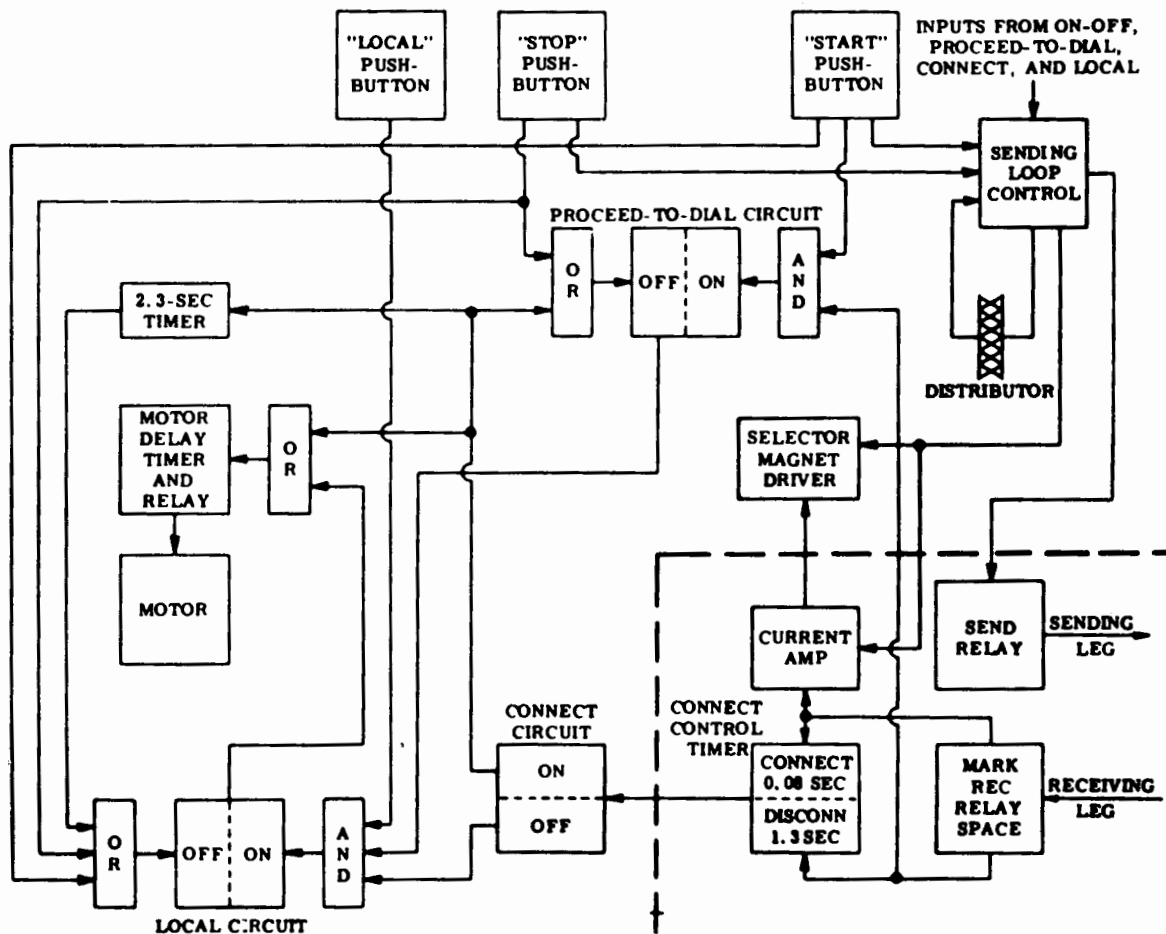

Figure 10 - Polar Adapter Circuit

3.64 If ground is applied to the emitter of Q5 through CR3 or by strapping binding posts no. 1 and 2, the base is reverse-biased by the voltage divider made up of R13 and R14. If base current is now supplied, the transistor will turn on. With the collector load as shown in Figure 12, 0.060 ampere of collector current will flow.

3.65 If the ground to the emitter of Q5 through CR3 is switched to +120 volts, CR3 will become back-biased. The emitter is biased to near +18 volts through R12. Since both the emitter and collector are biased to +18 volts, no current will flow between them. Base current supplied to the transistor will flow into both the collector and emitter. The current in the collector will flow from the base, through the collector, the selector magnet driver, and R23 to +18 volts. This current flow is in the reverse direction of the normal control current for the selector magnet drive, and it will be held spacing.

3.66 The amplifier will supply marking current only when ground is applied to the emitter, and the base current is supplied. If either of these conditions is not fulfilled, the selector magnet driver will not be supplied input current, and its output will be spacing.

3.67 Strapping posts no. 1 and 2 will permanently apply ground to the emitter and allow duplex operation of the teletypewriter.

F. Circuit Interconnections

3.68 Figure 10 is a block diagram showing the polar adapter connected to the call control unit. The call control unit portion of the block diagram is the same as that shown in Figure 7 with one exception. The line sensing and control block of the call control unit is now called the sending loop control. All of the components are identical in these two blocks, but rewiring allows the block to control the sending leg rather than the signal loop. This block also has outputs to the current amplifier and the selector magnet driver. The input to the current amplifier allows the teletypewriter to read its own copy. The input directly to the selector magnet driver is for teletypewriter blinding.

3.69 The receiving polar relay marking contact supplies inputs to both the connect control timer and the current amplifier. The input to the current amplifier allows the teletypewriter to read incoming copy. The input to the connect control timer allows the polar adapter to recognize a connect signal. The spacing contact supplies inputs to both the connect control timer and the proceed-to-dial circuit of the call control unit. The input to the connect control timer allows the polar adapter to recognize a disconnect signal. The input to the proceed-to-dial circuit supplies current for spacing signals and no current for mark. This allows this circuit to operate in the normal manner.

G. Idle Line Condition

3.70 In this condition both the sending and receiving legs are spacing. All the circuits in the call control unit are off. The spacing contact of the receiving polar relay is +120 volts and allows C4 to be discharged. CR4 will then allow strobe pulses to pass to the base of Q3 and hold it off. The output of the connect control timer is then negative and holds the connect circuit in the call control unit off.

3.71 Figure 11 is a schematic wiring diagram of the sending loop control circuit with the current amplifier and the sending polar relay. Blinding current to the selector magnet driver flows from +18 volts through R23, J5-2, the selector magnet driver, J4-3, and "hl" contact, the "wl" contact, J4-9, and the distributor to ground. No current flows in the drive coils of the sending polar relay, since neither the start contact, the "a" contact, nor the "hl" contact are operated to supply ground.

3.72 The marking contact of the receiving polar relay has no voltage applied. No base current will then flow from this contact to Q5. The emitter of Q5 is biased to +18 volts through R12. The cathode of CR3 is at +120 volts which is supplied through R39 and the sending relay coils, and CR3 is back-biased.

H. Initiating a Call

3.73 A call may be initiated when the call control unit is in either the idle line or local conditions as described earlier. Depressing the START pushbutton will allow current to flow through the drive coils of the sending polar relay. This sending polar relay will then transmit a marking signal on the sending leg. The current path through the coils is shown by the dotted line in Figure 11.

3.74 Operating the START pushbutton will also remove ground from the collector of Q1 in the call control unit. Current to the input of the proceed-to-dial circuit (base of Q1) is supplied from the spacing contact of the receiving polar relay. This is not shown in Figure 11. The proceed-to-dial circuit will not operate until this current is interrupted.

I. Proceed-to-Dial

3.75 The exchange will recognize the marking signal transmitted as a request to dial. When the exchange has selected the proper equipment, it will transmit a 0.025 second marking signal on the receiving leg. The receiving polar relay will respond to this signal by interrupting the current flow to the input of the proceed-to-dial circuit. This circuit will then turn on, and energize the (K1) relay and the proceed-to-dial lamp. The "a" contact will operate and shunt out the START pushbutton contact. The START pushbutton may now be released.

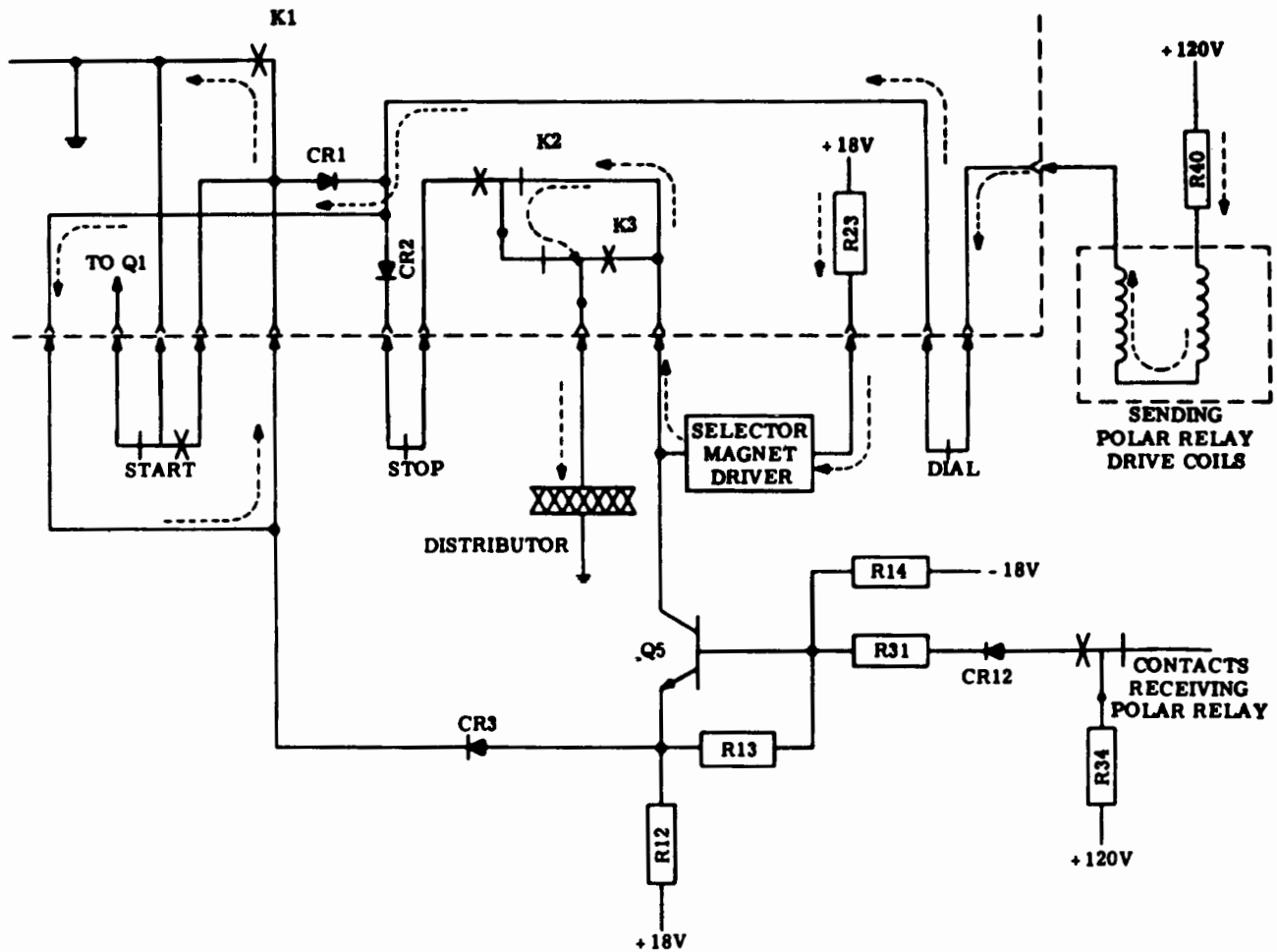

Figure 11 - Sending Loop Control Circuit With Sending Polar Relay

3.76 When the receiving polar relay responds to the 0.025 second pulse, C3 in the connect control timer will start to discharge. After 0.025 second the receiving leg returns to spacing and causes C3 to be recharged to -60 volts. In the 0.025 second interval, the voltage across C3 will not rise to -9.1 volts, and no strobe pulse will be passed by CR5. The connect control timer, therefore, will not respond to a proceed-to-dial pulse.

J. Dialing

3.77 The dial signaling contacts are in series with the drive coils of the sending polar relay as shown in Figure 11. The dial contacts will thus energize and de-energize this relay whenever current is flowing through them. The make-break signal generated by the dial contacts will be transmitted as mark-space signals by the sending polar relay. These mark-space signals are used by the exchange to make the necessary connection.

K. Call Connection

3.78 With the call control unit in the proceed-to-dial condition, the sending leg is marking, and the receiving leg is spacing. When dialing is completed, the exchange will switch the receiving leg to marking. This signal causes the tongue of the receiving polar relay to transfer and apply +120 volts to R28. CR8 will become reverse-biased, and C3 will begin to discharge toward ground. After 0.080 second, the voltage across C3 will be approximately -9.1 volts. The next strobe pulse to appear will pass through CR5 to the base of Q4. The output of the connect control timer will then become positive and cause the connect circuit to turn on. As described earlier, the proceed-to-dial circuit will turn off. As the connect circuit turns on, the (K2) relay will operate, the "hl" contacts will transfer, the CONN lamp will light, and the motor will turn on.

3.79 Current flow to the drive coils of the sending polar relay is now through R40, the drive coils, the dial contacts, CR2, the stop contacts, K1, K2, and the keyboard

contacts to ground as shown in Figure 12. Base current to Q5 is now supplied from the marking contact of the receiving polar relay through CR12 and R31. Input current to the selector magnet driver will flow from +18 volts through R23, the selector magnet driver, Q5, CR3, CR2, the stop contacts, K1, K2, and the distributor contacts to ground.

3.80 Both the current paths for the drive coils of the sending polar relay and the selector magnet driver are through the distributor contacts. If the distributor is operated, the signal will be transmitted on the sending leg and cause the selector magnet of the teletypewriter to operate. When information is received from the distant station, the receiving polar relay will operate and make or break base current to Q5. This will cause Q5 to make or break current flow to the selector magnet driver without affecting the sending circuit.

3.81 The longest possible normal spacing signal generated by the distant teletypewriter will be less than 1.3 seconds. This is the length of spacing signal required

to cause the connect control timer to disconnect. Therefore, under normal signaling, the connect control timer will not be affected by information signals.

L. Remote Connection

3.82 The call control unit may be connected remotely from either the idle line or local condition. An incoming call is indicated by the exchange by its transmission of a marking signal on the receiving leg. The connect control timer after 0.080 second, will turn on the connect circuit in the control unit. A current path to ground is set up through the drive coils of the sending polar relay. It will then transmit a marking signal on the sending leg to signify that the unit has connected. The remainder of the operations are the same as described in 3.78 through 3.81.

3.83 If the paper in the teletypewriter has become low and the low-paper contacts operate, the voltage across C3 will be held at -60 volts through R29. This will stop any connections from occurring. If the call control unit is

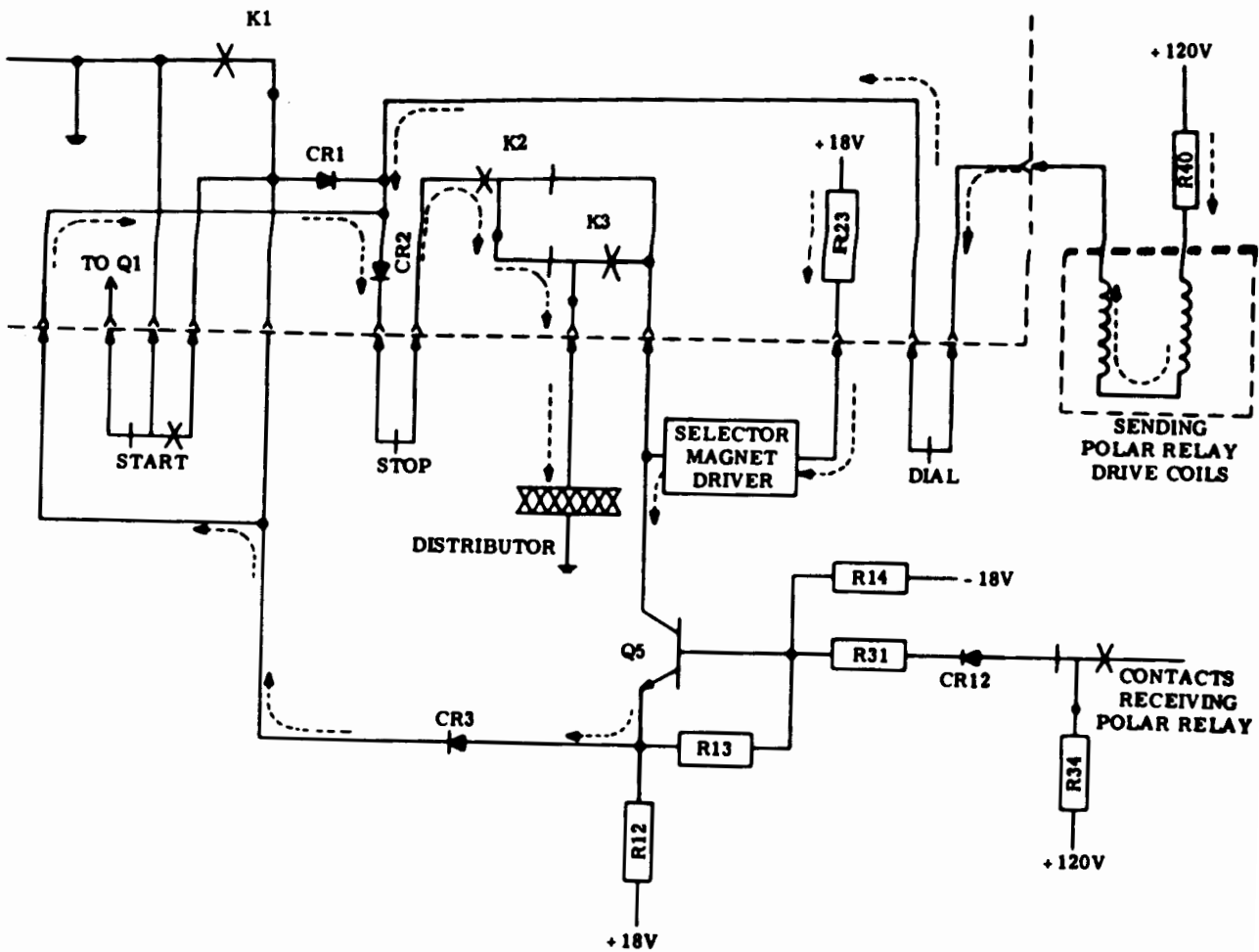

Figure 12 - Receiving Loop Control Circuit With Receiving Polar Relay

already in the connect condition, when the low-paper contacts close the call may be completed, but subsequent connections will be blocked.

3.84 If a call is originated locally with a low-paper condition, the normal sequence of events will occur until the connection is attempted. When the exchange does not receive a marking signal on the sending leg, it will turn the receiving leg to spacing (idle line condition).

M. Call Disconnect

3.85 If the STOP pushbutton is depressed while the teletypewriter is in the connect condition, the stop contacts in series with the drive coils of the sending polar relay will open. The relay output will then be spacing. The exchange will recognize this long spacing signal as a request to disconnect and will send a spacing signal on the receiving leg. The receiving polar relay contacts will transfer and allow C4 to discharge toward ground. After 1.3 seconds, the voltage across C4 will be -9.1 volts, and the next strobe pulse will pass through CR4 to the base of Q3. The output of the timer will become negative and turn off the connect circuit in the call control unit. Current to the drive coil of the sending polar relay will be held off so that the STOP pushbutton may be released. The K2 contacts will now also supply blinding current to the selector magnet driver. The control unit is now in the idle line condition.

N. Remote Disconnect

3.86 When the remote unit generates the spacing signal to disconnect, the receiving polar relay will allow C4 to discharge and after 1.3 seconds the timer will turn off the connect circuit. The K2 contacts will transfer, stopping current flow to the drive coils of the sending polar relay and blinding the selector magnet driver. The call control unit is now in the idle line condition.

O. Local Off-Line Operation

3.87 This operation is identical to that of the call control unit without polar adapter except for the current path to the selector magnet driver. This path is shown in Figure 11.

4. PRIVATE WIRE SERVICE

INTRODUCTION

4.01 Power for the motor, selector magnet driver, local power supply, and tape reader power pack, when provided, is supplied from fused 115-volt ac, 60 Hz power. Direct current of either 0.020 or 0.060 ampere is required for the signal line(s) and for operation in the local mode. Battery for the signal line(s) is supplied by the customer's facilities, while local battery for operation in the local mode is

furnished through the operation of the local power supply circuit in the call control unit. At the rear of the call control unit is a terminal strip which provides the point of entry for the ac power and the signal line(s) into the teletypewriter.

4.02 The purpose of the selector magnet driver is to amplify received dc marking and spacing intelligence pulses. Received dc intelligence pulses are directed to the input of the selector magnet driver circuit in the call control unit where they are amplified and returned as 0.500 ampere dc intelligence pulses to operate the typing unit selector. A detailed description of the operation of a selector magnet driver is given in 2.92 through 2.102. The selector magnet driver described there is similar to the ones used in private wire service.

A. Power Switch and Local Power Supply Circuits

4.03 The 3-position rotary switch (electronically shown in Figure 13) is the only manual control on the call control unit. Through its operation the teletypewriter can be (1) placed in the external signal line loop for communication with other teletypewriters, (2) removed from the external signal line loop for local operation, or (3) placed in the off condition.

B. Mode Chart

4.04 The following chart indicates the condition of the rotary power switch contacts – either open or closed – when the control knob is turned to one of its positions:

KNOB POSITION	LINE SEGMENT		CONTACTS CONDITION
	FROM	TO	
LINE	L1	2	Closed
	L1	1	Closed
	L2	2	Open
LOCAL	L1	2	Closed
	L1	1	Open
	L2	2	Closed
OFF			All Open

OFF MODE



A. Power Circuit

4.05 All power in the call control unit, except that applied to the selector magnet driver is off.

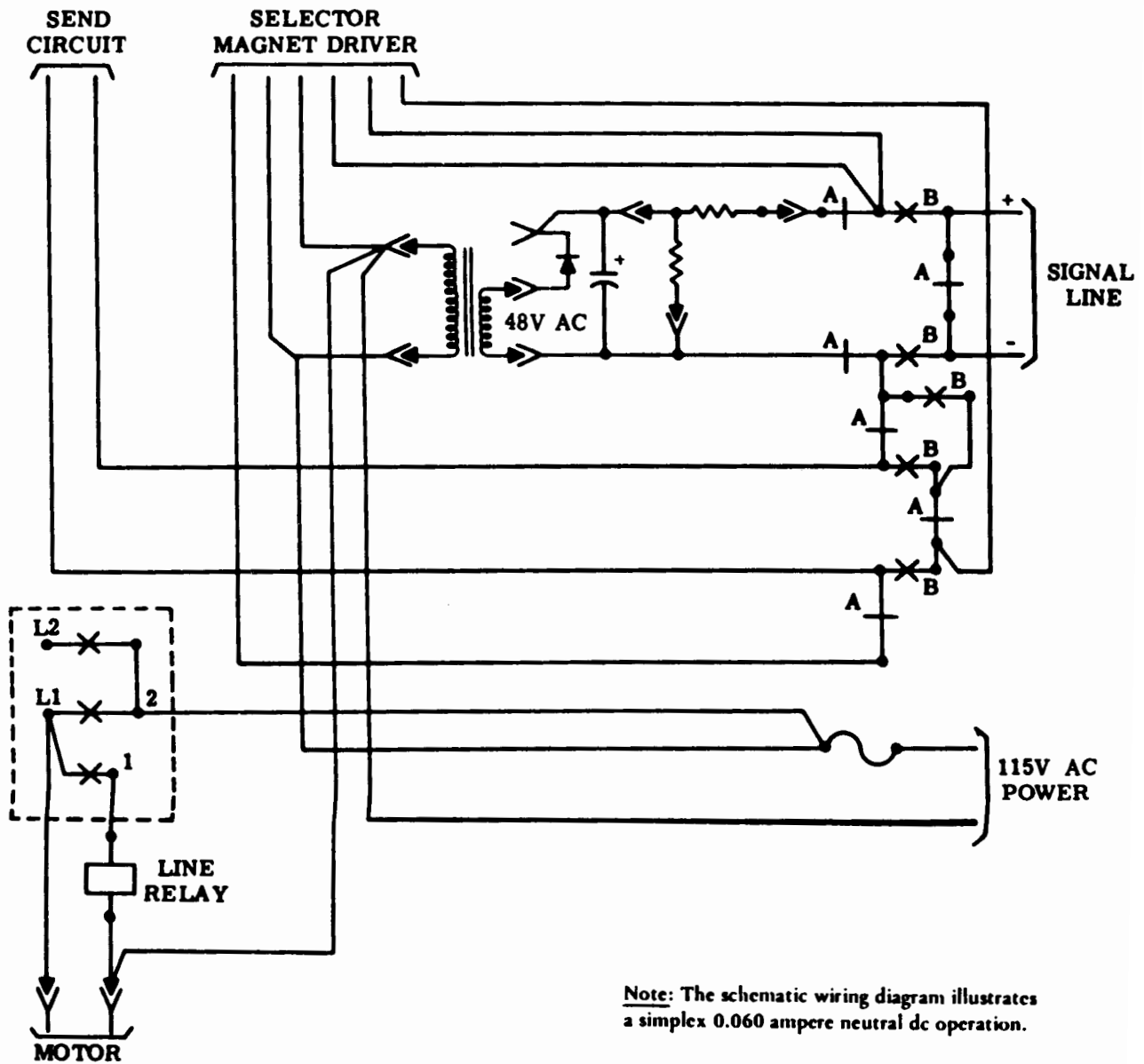

Figure 13 - Rotary Power Switch and Local Power Supply Circuit

B. Signal Circuit

4.06 The signal line is diverted around the local teletypewriter so other teletypewriters in the external signal line loop can communicate without interference.

LOCAL MODE**A. Power Circuit**

4.07 The line relay is not energized and the local battery is supplied to the selector magnet driver and the send circuit.

B. Signal Circuit

4.08 The normally closed contacts A remain closed, and the normally open contacts B remain open. The external signal line loop is divorced from the selector magnet driver, and shunted so that other teletypewriters in that loop can communicate without being affected by the operation of the local teletypewriter.

LINE MODE**A. Power Circuit**

4.09 The line relay is energized and the battery is on the signal line.

B. Signal Circuit

4.10 The normally closed contacts A will open and the normally open contacts B will close. The external signal line loop is united with the selector magnet driver and the local teletypewriter can now communicate any other teletypewriters in that loop.

4.11 Any transmission from the keyboard or tape reader, if provided, will cause the typing unit distributor to send start-stop signals to other teletypewriters in the external signal line loop. Also, the local teletypewriter is able to receive the start-stop signals transmitted from other teletypewriters in the same external line loop.

33 TELETYPEWRITER SET
INSTALLATION

CONTENTS	PAGE	
1. GENERAL	1	1. GENERAL
UNPACKING	1	1.01 This section provides installation instructions for the 33 Teletypewriter Set. It is reissued to consolidate information and make some minor changes throughout the section. Marginal arrows have been used to indicate the changes.
PREPARATION FOR INSTALLATION	2	
2. INSTALLATION	3	1.02 References to left, right, front, or rear, etc, consider the teletypewriter set to be viewed from a position where the typing unit carriage faces up and the typing unit selector mechanism is located to the viewer's left.
MOUNTING TYPING UNIT ON STAND	3	
CODING ANSWER-BACK DRUM	3	
ELECTRICAL CONNECTIONS AND PRE-SERVICE PROCEDURES	8	1.03 Tools and materials used for teletypewriter set installation are shown in Section 570-005-800TC.
PLACEMENT	12	
A. Without Stand	12	
B. With Stand	12	<u>Note:</u> To avoid injury, take special care when working with a teletypewriter set connected to its power supply.
3. FINAL ASSEMBLY	12	1.04 Leads for the signal line must be furnished by the customer.
GENERAL	12	
RIBBON INSTALLATION	12	UNPACKING
PAPER OR FORM INSTALLATION	12	1.05 The teletypewriter set is packed in one carton. Observe all caution and instruction labels on the carton before breaking the seals.
A. Friction Feed	12	
B. Sprocket Feed	14	
4. TAPE READER	15	1.06 Cut tape at center and end seams. Open carton and remove the upper filler pads. Remove typing unit carefully to avoid damaging the plastic cover. Take out the remaining carton fillers and the stand (if used).
5. POWER PACK ASSEMBLY	15	
6. TAPE PUNCH	17	
7. RESHIPMENT	18	
8. OPTIONAL FEATURES	20	1.07 The typing unit and subbase are mounted on a shipping pallet by six screws. Remove the six screws, being careful that the typing unit does not fall off the pallet. Once the shipping screws are removed, the typing unit is retained only by the cover.
A. Copyholder	20	
B. Busy Circuit	20	
C. Hand Receiver	20	

Note: Retain the forward mounting screw and associated flat washer. This screw is used to secure the typing unit when shipped to another location without its cover fastened in place. The screw and washer may be stored in the TP181104 cable clip (included in bag of hardware with pedestal mounted units) to be mounted on the typing unit frame between the two dashpot mounting screws (Figure 1).

1.08 Remove typing unit from the shipping pallet.

CAUTION: DO NOT TILT THE TYPING UNIT AFTER IT HAS BEEN REMOVED FROM THE PALLET. THE TYPING UNIT FLOATS ON RUBBER ISOLATORS AND MAY PULL LOOSE IF IT IS TILTED.

PREPARATION FOR INSTALLATION

1.09 Remove the tape from across the top of the cover and take out the cables, platen knob, and paper spindle from the paper recess. Unwrap the parts.

1.10 Remove the call control bezel, if used, after removing its two mounting screws. Remove volume control knob or power switch rotary knob, if used, by pulling knob forward. Detach the nameplate (Figure 2) by pulling it down and out. Remove the four front and three rear cover mounting screws.

Note: On Automatic Send-Receive (ASR) Sets, remove the screw from the left rear corner of the tape reader cover.

Gently lift the cover from the subbase.

1.11 Remove the twist tie holding the carriage to the left side frame of the typing unit.

1.12 If a stand is used, remove its two rear panel mounting screws and take panel off. Remove the copyholder, if used, from inside the stand. Remove the bag tied to the stand and place its hardware contents on the bench.

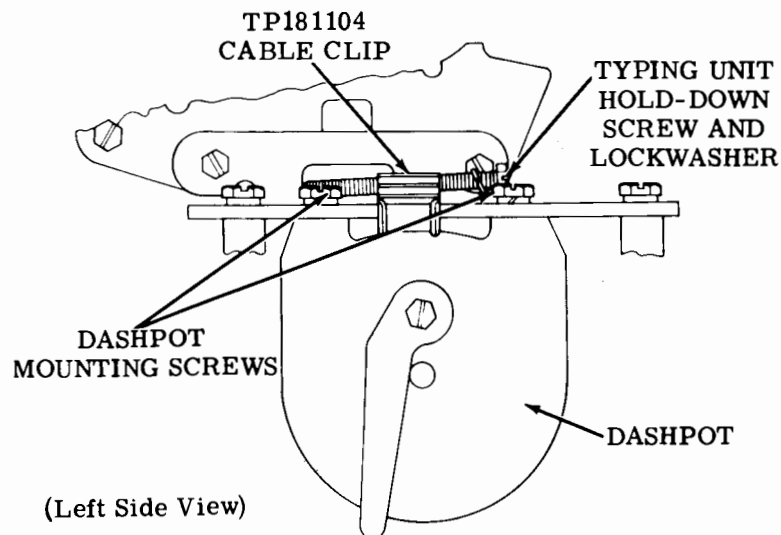

Figure 1 - Typing Unit Hold-Down Screw Storage

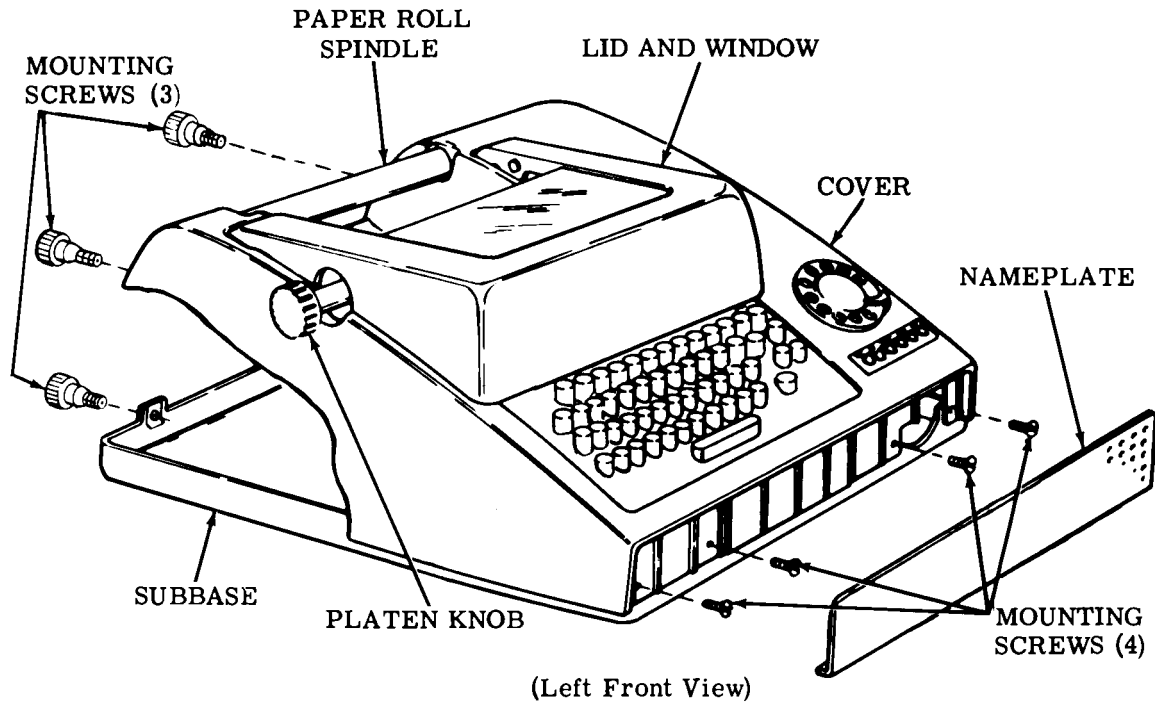

Figure 2 - Cover Mounting

1.13 Use the supplied screws to fasten the data set, if used, to the relay rack.

1.14 The teletypewriter set should be thoroughly lubricated before placing it into service and relubricated after the short period of service specified in the lubrication sections. Thereafter, maintain the regular lubrication intervals as required in the appropriate lubrication sections.

2. INSTALLATION

MOUNTING TYPING UNIT ON STAND

2.01 If the teletypewriter set is to be bolted to the floor, remove the front screw in each leg of the stand (Figure 3).

2.02 Install the plug button, included in the bag of hardware, in the forward hole in the bottom of the subbase.

2.03 Place the subbase and typing unit on top of the stand so that its back edges and sides line up with the back edges and sides of the stand. Install the two retaining clips, included in the hardware bag, on the base at the rear (one each end) and snap them in place on the stand. Refer to Figure 4.

2.04 Mount the base to the stand from the bottom with four no. 14Z screws and associated flat washers.

CODING THE ANSWER-BACK DRUM

2.05 To remove answer-back drum for coding, press back and down on the tab portion of the TP180854 brace until it becomes detented in its open position. Lift feed pawl slightly (do not overextend its spring) and remove drum.

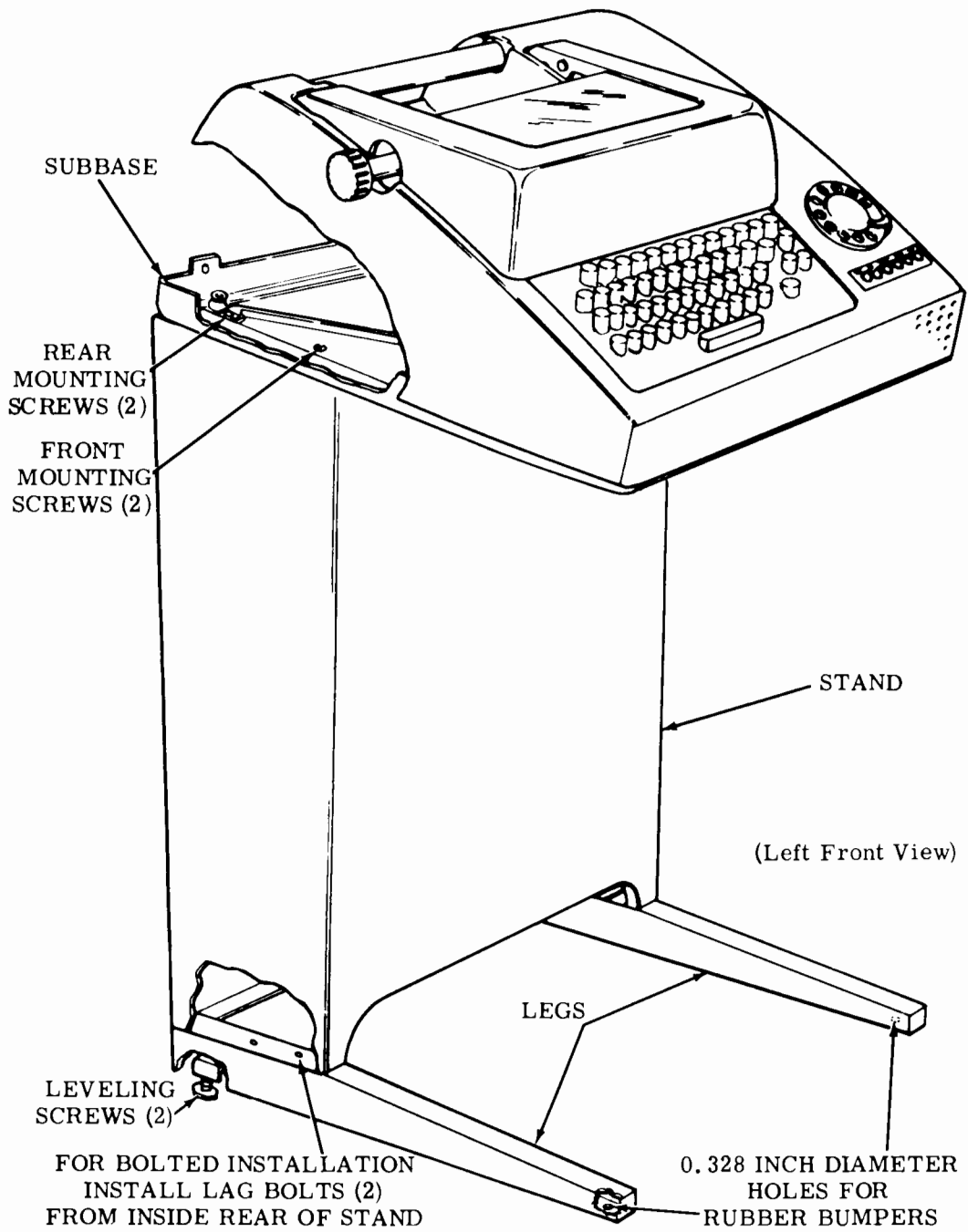

Figure 3 - Stand Leveling and Anchoring and Assembly of Subbase with Typing Unit to Stand

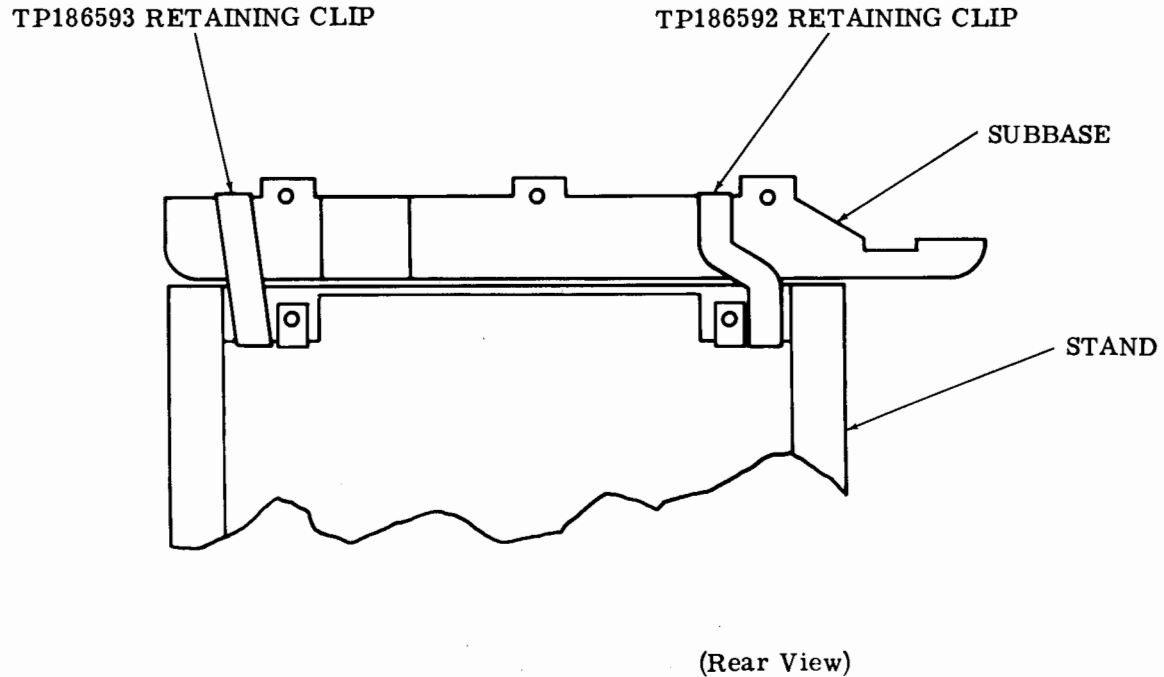

Figure 4 - Installation of Retaining Clips to Subbase and Stand

2.06 Code the answer-back drum in a counter-clockwise direction (Figures 5 and 6), starting with row no. 1.

Note: The ST row is the first row sensed at the beginning of an answer-back cycle. It is coded at the factory for character suppression and must not be recoded.

2.07 A particular character is coded by either retaining or removing tines within a row, as illustrated in Figure 5. A tine may be removed by either of the two following methods:

(a) Method 1: Place the end of a screw-driver blade at the base of a tine in the row previously coded. Press the side of the

blade against the top of the unwanted tine until the tine breaks off. Figure 5 illustrates this method — pressure applied to base of row no. 18 and against top of adjacent tine being removed from row no. 19.

(b) Method 2: Place the unwanted tine in the slot of a TP161686 tine tool, or grasp the tine firmly with long-nose pliers. With the tool or pliers held stationary, rotate the answer-back drum back and forth until the unwanted tine breaks off near its base. Do not damage adjacent tines.

Note: If a coding error is made, or for some other reason it is necessary to suppress (erase) characters from the answer-back drum, remove the character suppression tine from the row(s) affected.

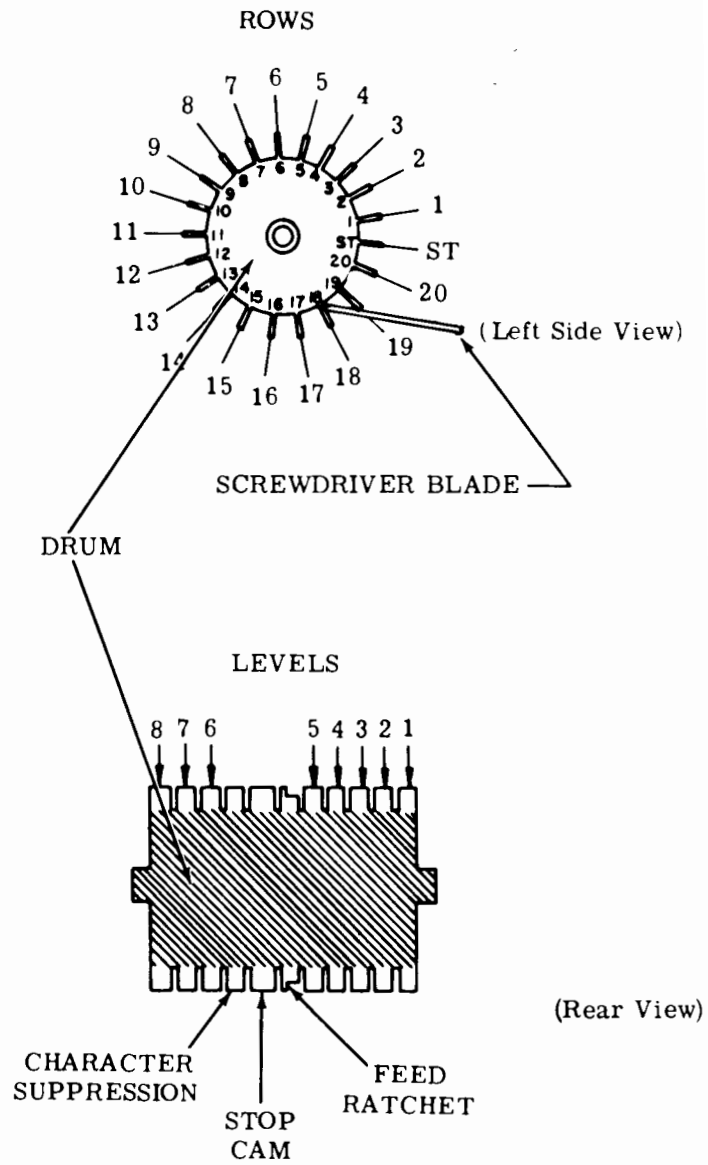

Figure 5 - Answer-Back Drum

2.08 The length of an answer-back sequence can be varied either by removing the stop cam tine(s) and/or the character suppression tine(s).

(a) For short sequences, code the drum for either 2- or 3-cycle operation by removing the appropriate tine(s) as indicated in Figure 6.

(b) Removal of the character suppression tine from any row prevents transmission from the answer-back mechanism. To shorten the answer-back sequence, remove the suppression tine from any unused row(s) after the end of a message.

Note: Do not remove the character suppression tine from the last row of each segment of the answer-back drum — row no. 20 for answer-back drums coded for 1-cycle operation — on sets used in systems where a response to each answer-back activation signal must be obtained. The last row can be coded with any other character that is compatible with the particular system.

2.09 The number of rows available for message coding is shown below for 1-, 2-, or 3-cycle operation.

CYCLE OPERATION	TOTAL ROWS	AVAILABLE ROWS
1	21	20
2	10 (11)*	9 (10)*
3	7	6

*Alternately one, then the other.

2.10 The number of rows available for actual station identification is less than shown above, because each coded message should begin and end with CARRIAGE RETURN and LINE FEED (this may be altered in specific applications). This assures that the transmitted message will appear at the beginning of a line of the receiving teletypewriter set and eliminates overprinting.

2.11 In switched network service, the station identification for 1-cycle operation may not exceed 14 characters, including spaces. The answer-back drum should be coded as follows.

ABBREVIATION

KEY TO ABBREVIATION

ACK	Acknowledge
CR	Carriage Return
LF	Line Feed
RO	Rub Out
SP	Space
SUP	Character Suppression

(a) Example 1:

```
SUP CR LF RO
TELETYPE SP NILES CR LF ACK

Company           City
```

Station Identification
(Maximum-14 characters)

Note: In this system, the ACK character code combination must be the final significant character code combination in the coded answer-back message.

(b) Example 2:

```
SUP CR LF RO
ERIE SP BOST CR LF ACK SUP
                SUP SUP SUP SUP
Company           City
```

Station Identification
(Less than maximum number of characters)

Note: If the station identification is less than the maximum of 14 characters in length, then the remaining rows on the answer-back drum must be coded with the character suppression code according to Example 2 above.

2.12 To replace the answer-back drum, place the TP180854 brace in its detented open position, and lift feed pawl (do not overextend its spring). Replace drum with its shaft firmly seated in the contact block slots. Release feed pawl and TP180854 brace. Rotate answer-back drum to assure proper seating of its associated parts. Check that the contact wires are located in their proper slots.

ELECTRICAL CONNECTIONS AND PRE-SERVICE PROCEDURES

CAUTION: MAKE SURE POWER CORD IS NOT CONNECTED.

2.13 Refer to the appropriate wiring diagrams packed with the teletypewriter set.

2.14 Connect the signal line leads (supplied by customer) to the terminals on the terminal board at the rear of the call control unit as indicated in the wiring diagram.

2.15 Connect power cord to an ac source, 115 volt 60 Hz.

2.16 Check DASHPOT ORIFICE (Spacing Area) adjustment, since altitude may have some effect on dashpot operation. See Section 574-122-700TC.

2.17 Sets equipped with an answer-back mechanism must be tested for proper response to a predetermined call character such as WRU. The following procedure is recommended for performing this test.

- (a) Use a predetermined call character such as WRU, to call in the newly installed set.
- (b) The set should establish the connection and automatically transmit the answer-back message.

Note: Set will not respond if the suppression time has been removed from the last row. See 2.07 (b).

- (c) If proper response is not obtained, check and correct the answer-back area adjustments (Section 574-122-700TC), beginning with those of the following list.

DRUM POSITION
TRIP LEVER CLEARANCE
FEED PAWL POSITION
FEED LEVER POSITION
"HERE-IS" BELLCRANK POSITIONING
TRIP BAIL POSITIONING
CHARACTER SUPPRESSION CONTACT
WIRE GAP

2.18 The 33 Teletypewriter Sets are shipped from the factory with the automatic carriage return-line feed feature in the typing unit

disabled by means of clips. The clips mount over slots in the TP180950 front tie bar. To enable this feature on friction feed sets remove the clip over slot A. To enable this feature on sprocket feed sets remove the two clips, in slot A and slot L.

Note: Slot A is not stamped on the function casting. Refer to 574-122-700TC for orientation.

2.19 Connect the signal line leads (supplied by customer) to the terminals on the terminal board at the rear of the call control unit as indicated in the wiring diagram.

2.20 The 33 Teletypewriter Sets are shipped from the factory with the even parity option installed in the keyboard. The customer may:

- (a) Retain even parity, or
- (b) Wire the keyboard for the 8th bit always marking, or
- (c) Wire the keyboard for the 8th bit always spacing.

The wiring options are installed by connecting wires to terminals at the right front of the keyboard and at the left contact block (see Figure 7). The options are shown in the Keyboard Wiring Options Table.

2.21 Low Tape Contact Adjustments (for units ←
so equipped): ←

- (a) Operating Arm Adjustment (Figure 8): Replace cover. With tape spindle in place, there should be 5/16 inch to 7/16 inch clearance between operating arm and tape spindle. To adjust, bend operating arm.

- (b) Operating Arm Clearance (Figure 9): Remove cover. The operating arm should have a minimum of 1/8 inch clearance

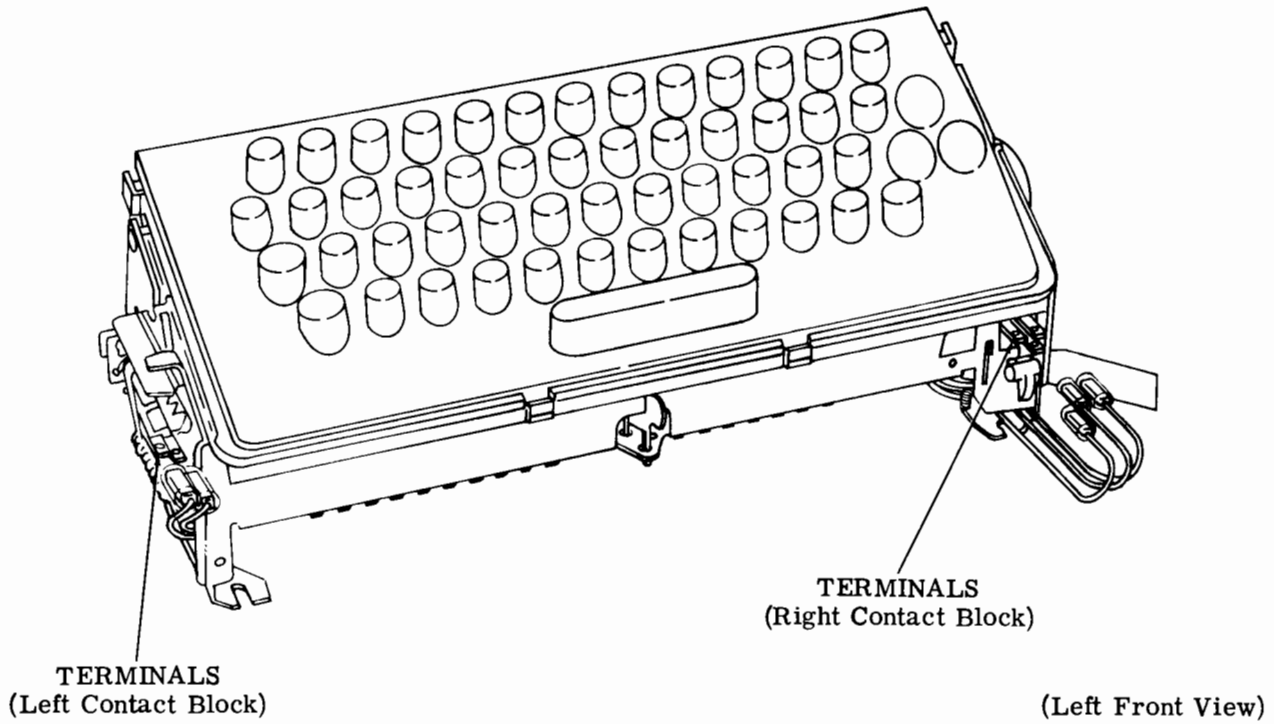

Note: Push the terminals on the contacts with long-nose pliers. It should be possible to install the parity options without removing the keyboard.

Figure 7 - Location of Terminals on Keyboard for Parity Options

KEYBOARD WIRING OPTIONS TABLE

OPTION	LEAD 1 Left Contact Block Color: Red-Green	LEAD 2 Left Contact Block Color: Green	LEAD 3 Right Contact Block Color: Green	LEAD 4 Right Contact Block Color: White-Slate
Even parity	ON	OFF	OFF	ON
8th bit Always mark	OFF	ON	ON	ON
8th bit Always space	Either Lead 1 or Lead 2 ON or both OFF		ON or OFF	OFF

Note 1: Tape and store unused leads.

Note 2: Reference: 9334WD

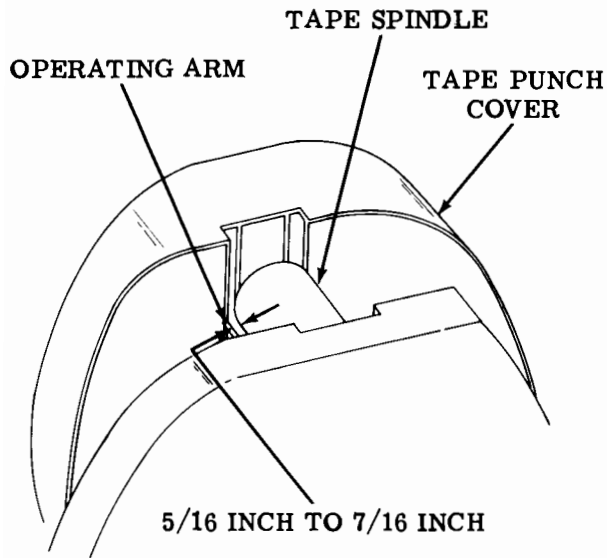

(Left Rear View)

Figure 8 - Operating Arm Adjustment

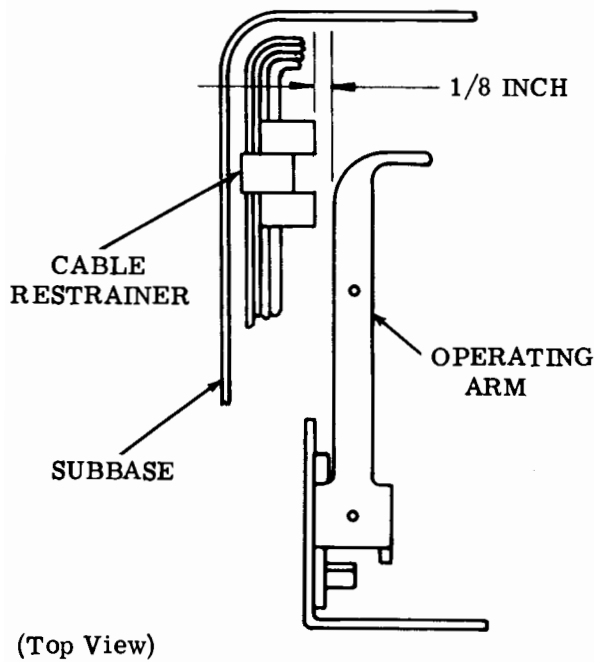

(Top View)

Figure 9 - Operating Arm Clearance

between the left edge of the operating arm at the closest point and the cables and cable restrainer at the left rear corner of the set. Gauge by eye. To adjust, bend switch bracket and/or reposition cables and reform cable restrainer.

(c) Operating Arm Clearance (Figure 10): Install cover. The tape roll should not touch the operating arm at any point other than the activating portion of the arm. To adjust, bend switch bracket and/or reposition cables and reform cable restrainer.

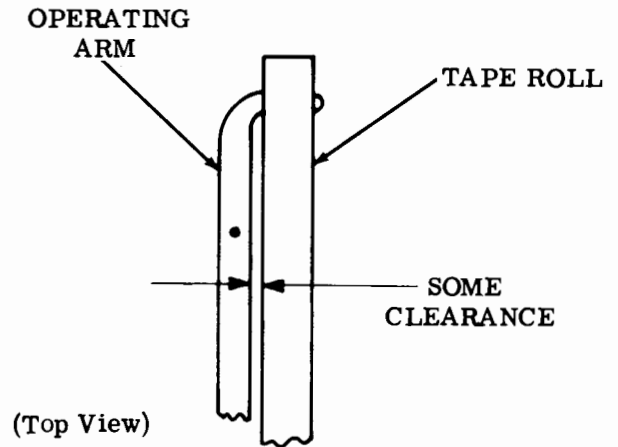

(Top View)

Figure 10 - Operating Arm Clearance

2.22 Air Deflector (Motor Area) Adjustment:

Note: This adjustment applies to 50 Hz sets only (so equipped).

(a) There should be at least 1/8 inch clearance at closest point between air deflector and motor fan. To adjust, position and/or bend air deflector.

(b) There should be some clearance between air deflector and the low paper alarm sensing rod so that the air deflector does not interfere or restrict the total travel of the sensing rod. To adjust, position and/or bend air deflector.

- 2.23 Connect power cord to ac source, 115 volt, 60 Hz or 50 Hz.

PLACEMENT

A. Without Stand

- 2.24 If a stand is not included, place the teletypewriter set on the surface where it is to be used.

B. With Stand

- 2.25 Figure 3 illustrates the facilities for leveling and anchoring the stand.

- 2.26 Place the partially assembled set where it is to be used. If the set rocks to one side or another, tip it slightly and reposition the leveling screws.

Note: Reaction to the carriage returning to its left position may cause early design teletypewriter sets to move across the floor toward the left. To correct this, either add weight to the stand, arrange to have it bolted to the floor, or drill one 0.328 inch diameter hole into each leg and install TP182285 rubber bumper in each leg.

- 2.27 If the teletypewriter set is to be bolted to the floor, place stand at the desired location and drive lag bolts into the floor through the front holes in the legs.

- 2.28 Place the relay rack inside the stand.

3. FINAL ASSEMBLY

GENERAL

- 3.01 Replace the back panel onto the stand, if used, using the removed screws.

Note: Before replacing an ASR cover, remove the retaining clip (early design units only) from the tape reader upstop screw (Figure 15). Also, prepare the punch for manual or automatic operation as described in 6.01.

- 3.02 Replace the cover over the typing unit and onto the subbase (Figure 2). Take care that all seams are tight and that keyboard push-buttons, dial, etc, are properly aligned. Insert and tighten the cover mounting screws removed during PREPARATION FOR INSTALLATION.

Note: On an ASR Set, insert and tighten screw at left rear corner of tape reader cover.

- 3.03 Replace the nameplate making sure that the formed lip fits around the bottom of the flange on the cover, that the top edge is behind the small lip on the cover, and that the bottom of the nameplate rests on top of the two small projections on the subbase.

- 3.04 Replace the volume control knob or the power switch rotary knob, if either is used, by positioning and pushing it rearward.

- 3.05 Position the bezel, if used, on the cover over the call control unit. Insert and tighten its two mounting screws.

- 3.06 On friction feed typing units, align the platen knob with the flat on the left side of the platen. Push knob in place. On sprocket feed typing units, install platen knob on left side of platen. Fully seat knob to the right and secure it with the screw provided.

RIBBON INSTALLATION

- 3.07 Figure 11 illustrates ribbon threading.

- 3.08 Raise the cover lid. Pull both spools off the friction spindles.

- 3.09 Engage the hook at the end of the ribbon in the hub of the empty spool; if there is no hook, pierce the end of the ribbon over the point of the arrow in the hub of the empty spool. Wind a few turns of ribbon onto the empty spool in the direction indicated by the arrow, and make sure that the reversing eyelet has been wound upon the spool.

- 3.10 Place the spools on the shafts in such a manner that the ribbon feeds to the rear from the right side of the right spool and from the left side of the left spool. Turn each spool slightly until the spool driving pin engages the hole in the spool. Guide the ribbon around the right vertical post and through the slot in the reverse arm. Place the ribbon in the ribbon guide behind the typewheel. Guide the ribbon through the left side of the reverse arm and around the vertical post. Rotate the spool to take up any slack.

PAPER OR FORM INSTALLATION

A. Friction Feed

- 3.11 A friction feed teletypewriter set accommodates a standard roll of paper 8-1/2 inches wide and 5 inches in diameter. Figure 12 illustrates paper threading for a friction feed typing unit.

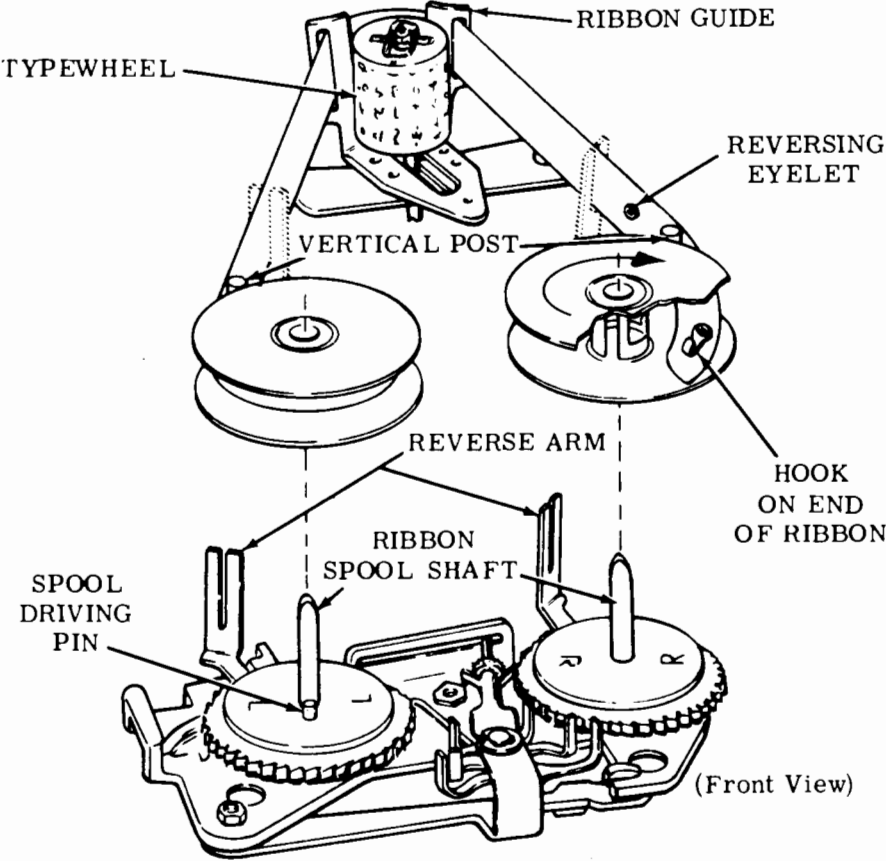

Figure 11 - Ribbon Threading

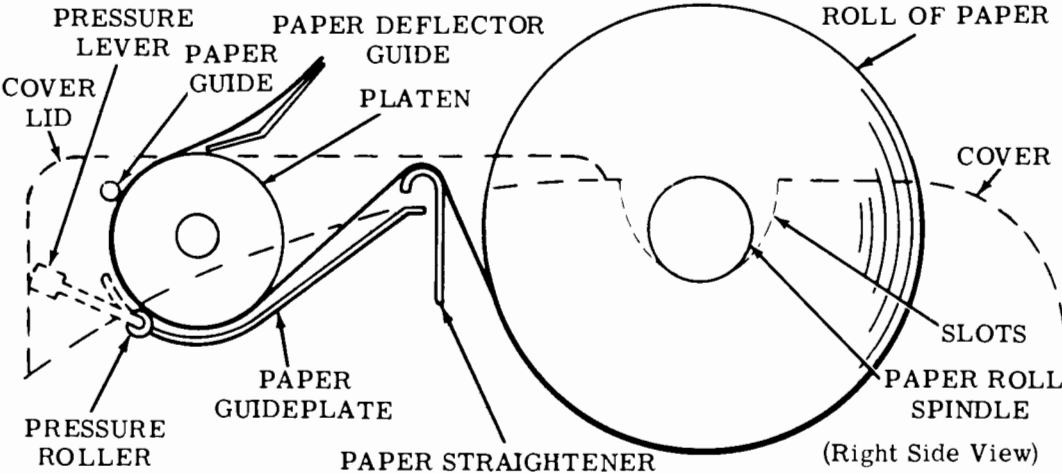

Figure 12 - Paper Threading — Friction Feed

3.12 Insert the paper roll spindle into the roll of paper so that an equal length of spindle is exposed at either end of the roll. Place roll into the cover recess with the ends of the spindle resting in the slots so that the paper will unroll from the bottom.

3.13 Raise the cover lid. Release pressure roller tension by moving the pressure lever forward. Prepare a smooth leading edge of paper. Pass paper over paper straightener, under platen, and under paper guide. Straighten paper and reapply the pressure roller tension. Close the cover lid.

Note: When typing units are stored or out of service for an extended period of time, release the pressure roller tension.

B. Sprocket Feed

3.14 A sprocket feed teletypewriter set accommodates forms 8-1/2 inches wide and of various lengths. The forms are normally passed to the typing unit from a conveniently located supply at the rear of the set.

3.15 Place the paper roll spindle into the paper recess of the cover so that it rests in the slots provided.

3.16 Figure 13 illustrates form threading for a sprocket feed typing unit.

3.17 **Form Threading:** Raise the cover lid. Pass the leading edge of the first form under the paper roll spindle. Thread the form under the low-paper and paper-out arms, if used, and between the platen and paper guideplate. Guide the form squarely into the platen and rotate the platen until the form is advanced by the sprocket pins. Lift up the wire guide and continue to rotate the platen until the form is under the wire guide and positioned for the first typing line. Lower wire guide and cover lid. After the first form is fed out, lift the form over the paper roll spindle to separate the incoming forms from the outgoing forms.

3.18 Figure 14 illustrates the zeroizing position of the platen drive mechanism for one cam lobe operation. For platen drive mechanisms using more than one cam lobe, see the CAM ZERO POSITION (Platen Drive Area, Sprocket Feed Mechanism) adjustment in Section 574-122-700TC.

3.19 **Zeroized Position:** Position a form at its first printing line in the typing unit. Depress the zeroizing button and rotate the pulley until the index plate is lined up with the pointer. Release the zeroizing button.

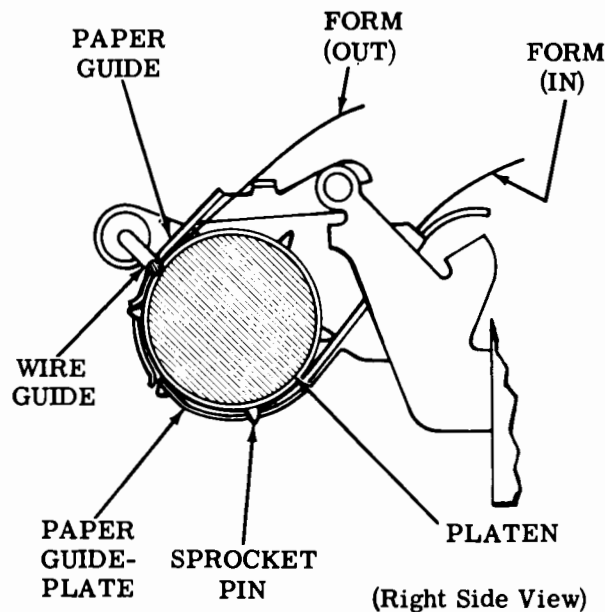

Figure 13 - Form Threading — Sprocket Feed

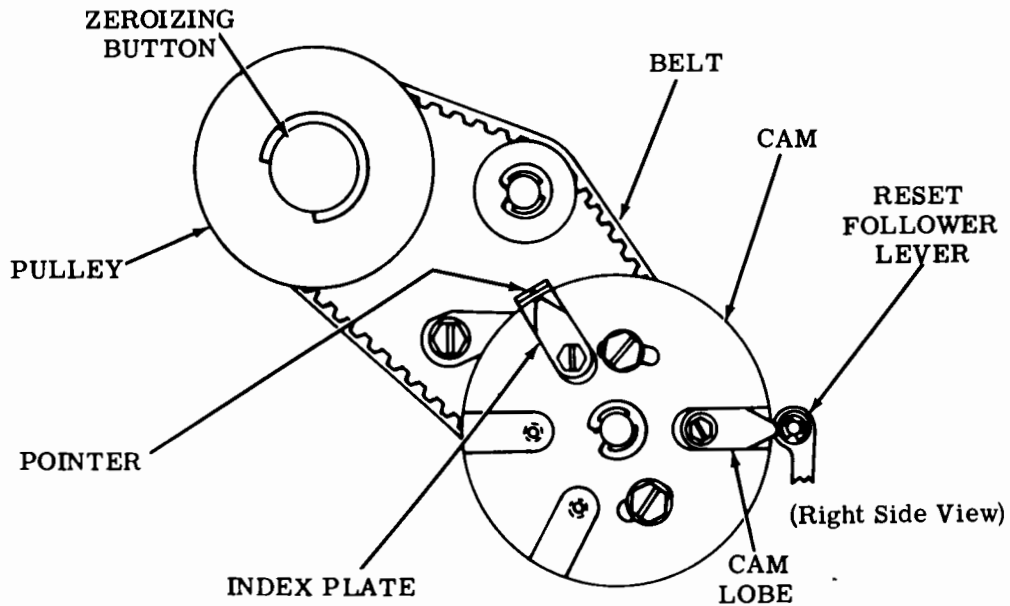

Figure 14 - Zeroizing Position of Platen Drive Mechanism — One Cam Lobe Operation

Note 1: To initiate the action to feed out a form, depress the CTRL and FORM keytops. The form-out mechanism will not respond to successive commands to feed out a form. At the end of a form feed-out, advance the form at least one line before issuing a second form-out command.

Note 2: The typing unit, in an ASR Set, operates one cycle behind the tape reader. Thus, a nonprint fill in code selection is required immediately after each form-out selection for proper set operation.

4. TAPE READER

4.01 A retaining ring or clip (Figure 15) is assembled (on early design units) to the upstop screw to prevent the sensing pins from being dislodged during shipment. This retaining clip must be removed before placing the tape reader in operation.

4.02 When inserting tape into the tape reader prior to operation, allow enough slack in the tape between the tape punch and the reader so that the reader lid can be easily closed.

CAUTION: THE TAPE READER OPERATES UNDER HIGH VOLTAGE. PRECAUTIONARY MEASURES SHOULD BE TAKEN WHENEVER POWER TO THE TAPE READER IS TURNED ON. HIGH VOLTAGE FROM THE POWER PACK WILL CONTINUE UNTIL APPROXIMATELY 10 SECONDS AFTER THE TAPE READER HAS BEEN DISCONNECTED.

4.03 Do not place the control lever beyond the STOP position while the tape reader is operating under power. The reader must come to a complete stop before placing the control lever in the FREE position.

5. POWER PACK ASSEMBLY

5.01 The sets have the power pack for the tape reader mounted in the call control unit; therefore, no installation is required. Should it be desirable to place other equipment in the call control unit, the reader power pack may be mounted inside the stand, underneath the base. Two clips attach the power pack to the stand at the left front corner when the set is viewed from the rear. See Figure 16.

5.02 The auxiliary ASR power supply is mounted in the enclosure of the stand. It is used in the off-line mode to provide 115 volts

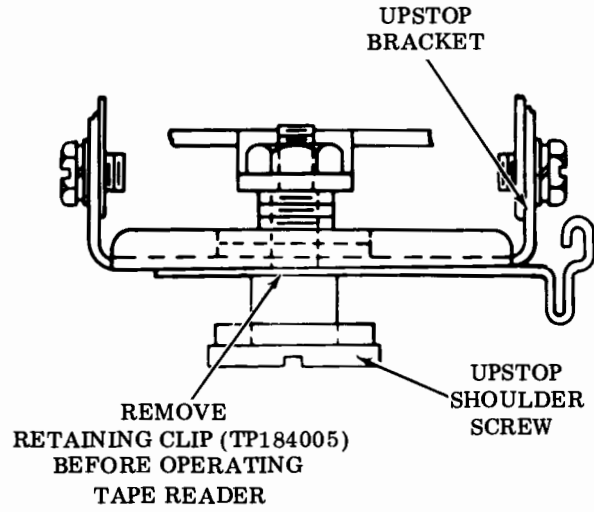

Figure 15 - Tape Reader Upstop Bracket Retaining Clip

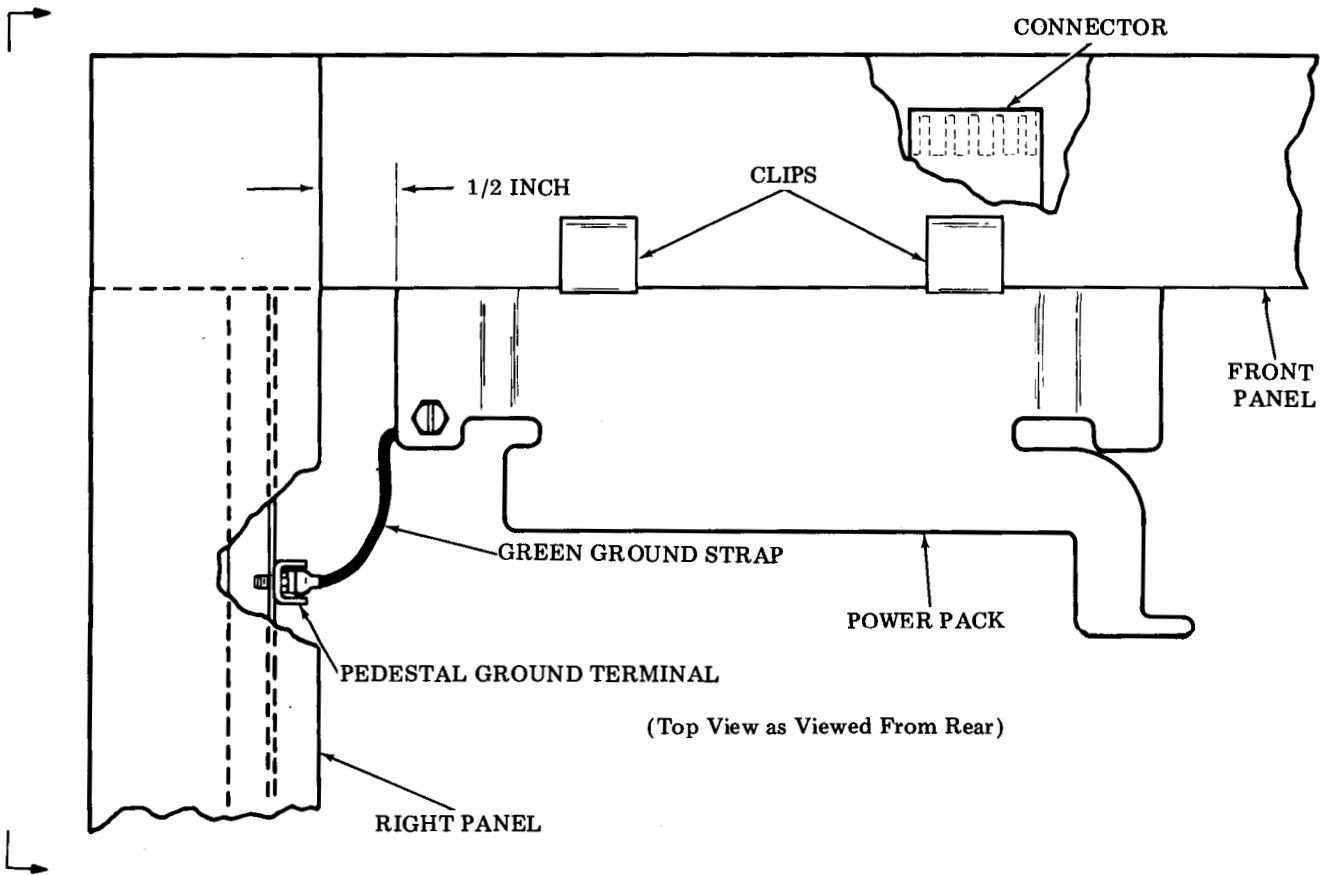

Figure 16 - Power Pack Assembly

on the tape reader, answer-back, and distributor contacts when a tape reader is used. When the tape reader is not used, a plug with a jumper wire is inserted in position R2 at the rear of the call control unit.

6. TAPE PUNCH

6.01 The 33 Teletypewriter Sets are shipped with the tape punch having two disabling clips installed in slots A-O and A-8. If manual operation of the tape punch is desired, retain the two clips; if automatic operation is desired, remove the two clips. See Figure 17.

6.02 Figure 18 illustrates the installation of a tape spool in a tape roll.

- (a) For 2-inch inside diameter tape rolls, use the tube-type spool.
- (b) For 1-inch inside diameter tape rolls, use the 2-piece spool.
- (c) Place the tape and spool into the tape punch cover so that the leading edge of the tape is at the top of the roll.

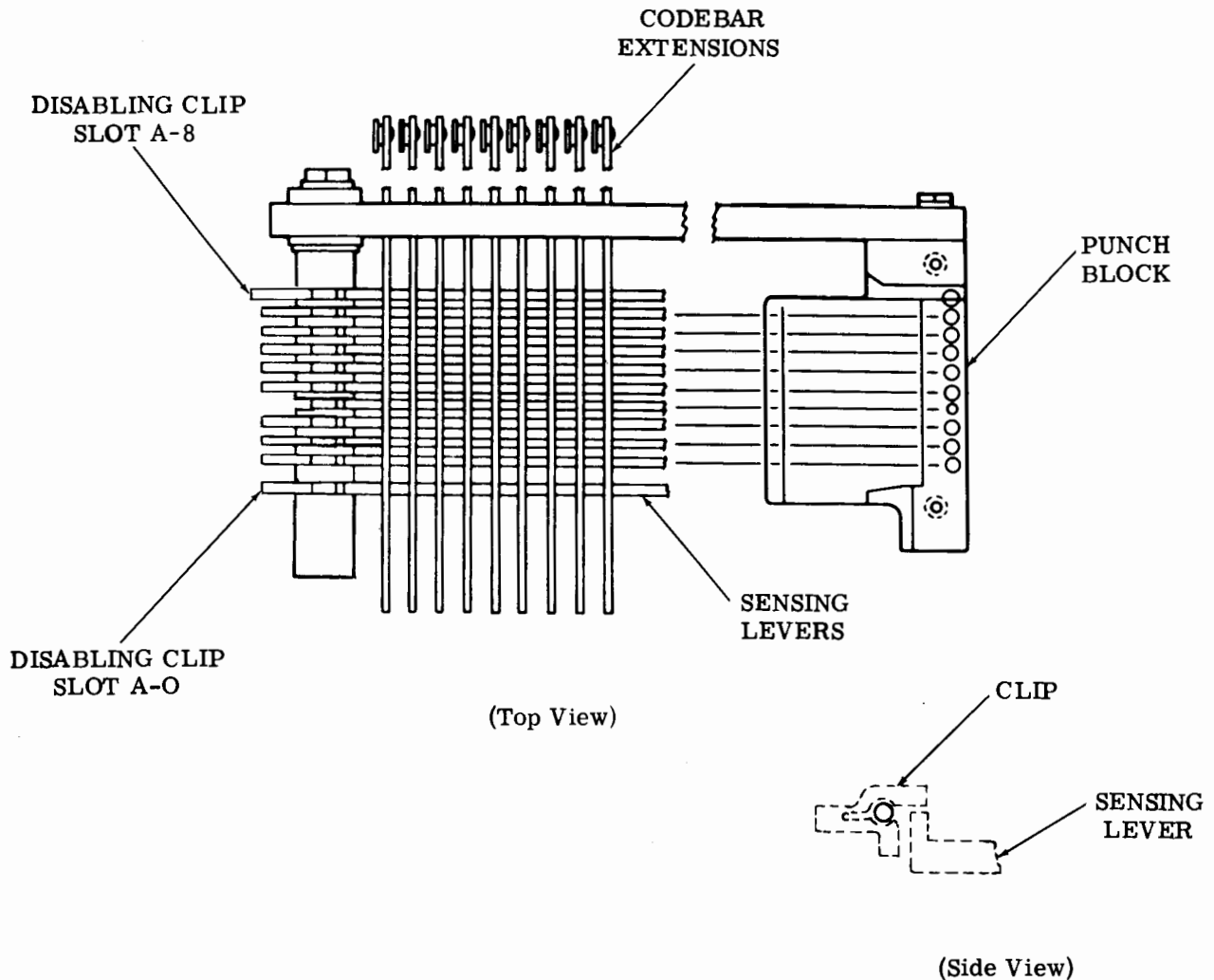

Figure 17 - Tape Punch Disabling Clips

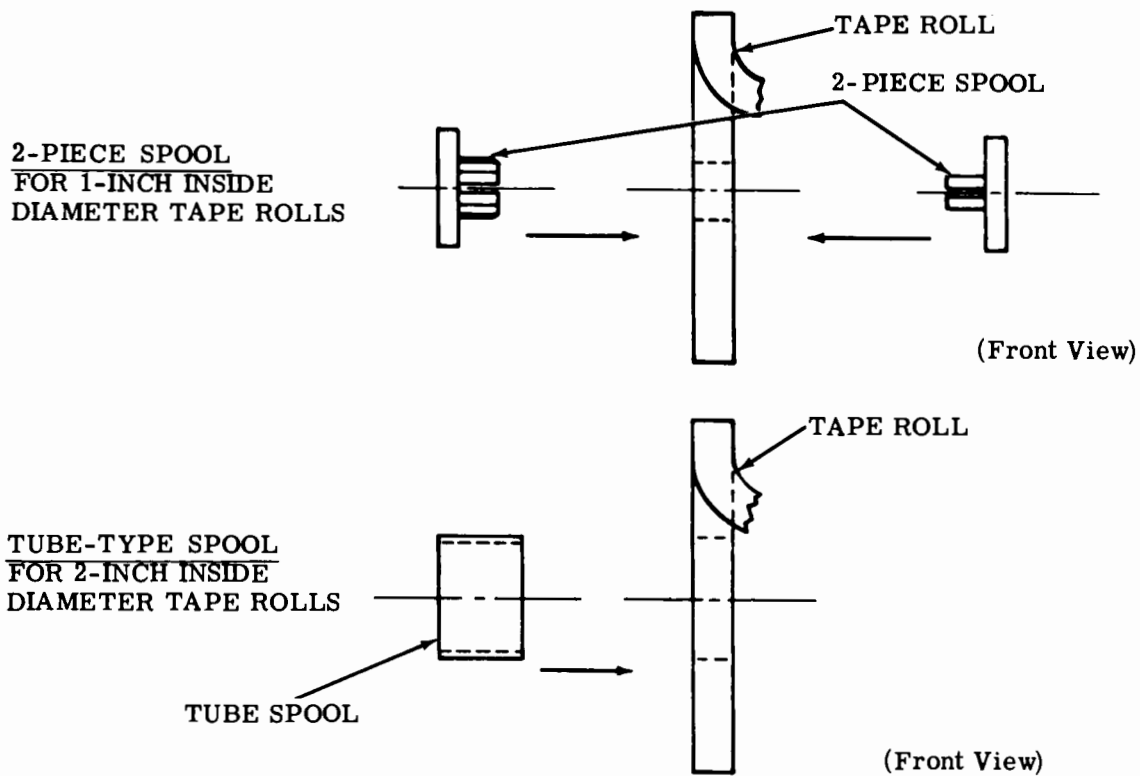

Figure 18 - Tape Roll and Tape Spool Assembly

6.03 Figure 19 illustrates the chad box installation.

- (a) Assemble the chad box under the tape punch pan by inserting the back of the flanged surface between the stand and the typing unit subbase.
- (b) Push the chad box toward the rear until the bent surface located at the front of the chad box engages the stand. An embossing located on the front bottom surface of the flanged surface engages an oblong hole in the stand and holds the chad box in place.
- (c) To empty the chad box, lift the front slightly and pull the chad box toward the front until it becomes disengaged.

7. RESHIPMENT

7.01 If the teletypewriter set is to be shipped to another location without its cover, the following must be done to avoid damage to the typing unit.

- (a) Remove subbase and typing unit from the stand.
- (b) Remove the plug button from the forward mounting hole in the bottom of the subbase.
- (c) Secure typing unit to the base by inserting and tightening the screw and washer previously stored in the TP181104 cable clip (1.09). Do not damage the typing unit by overtightening the screw.
- (d) Store the removed plug button in the TP181104 cable clip.

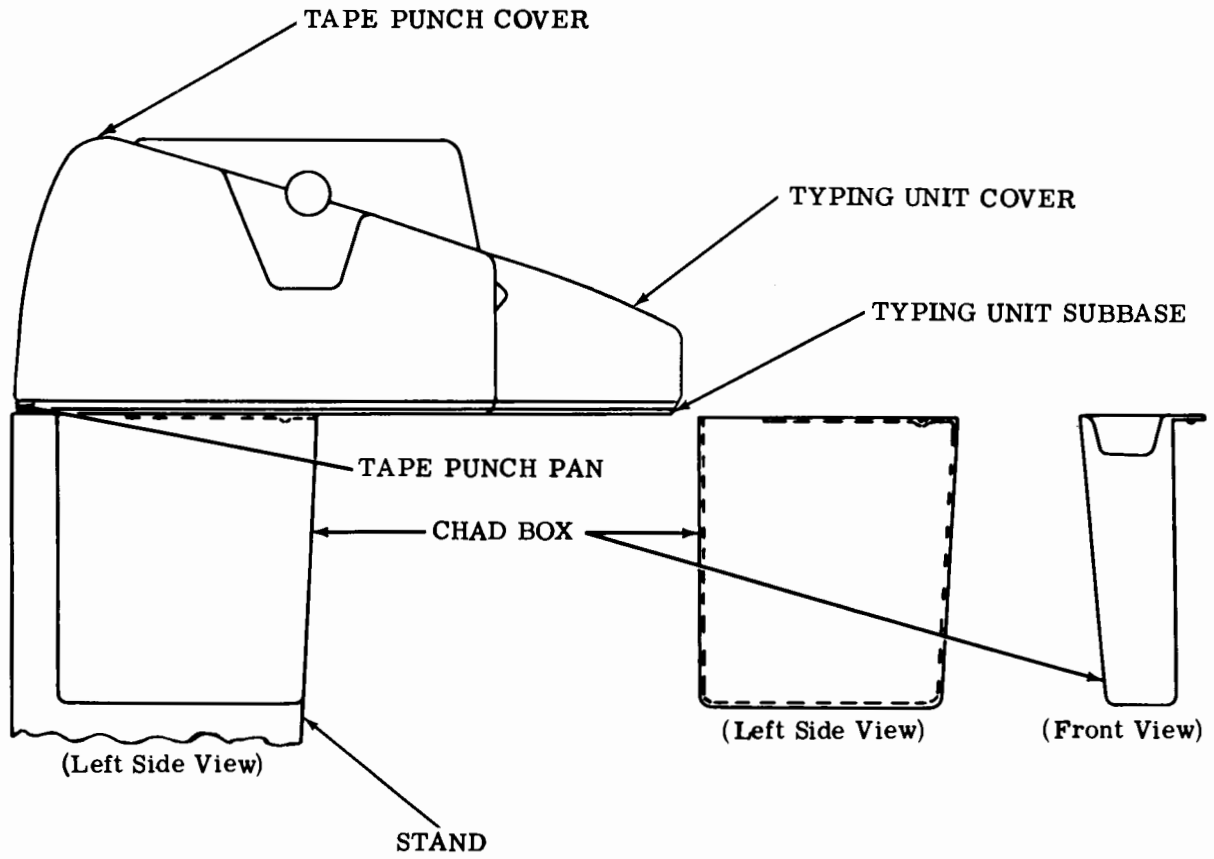

Figure 19 - Tape Punch Chad Chute Assembly

8. OPTIONAL FEATURES

A. Copyholder

8.01 With the line guide facing forward (Figure 20), insert the rear mounting tabs in the lower mounting slots. Pivot the copyholder to align the front mounting tabs above their mounting slots. Push copyholder downward until the tabs are fully seated.

B. Busy Circuit

8.02 The teletypewriter set is normally wired in a "don't answer" mode of operation for low-paper alarms and out-of-service. In this

mode, the set will not answer an incoming call. To wire the teletypewriter set to indicate "busy" instead of not answering, move the black-slate wire from terminal no. 2 to terminal no. 4 on the ringer terminal strip.

C. Hand Receiver

8.03 To install the hand receiver, connect the two white wires to terminals no. 5 and no. 6 on the 9-point terminal board.

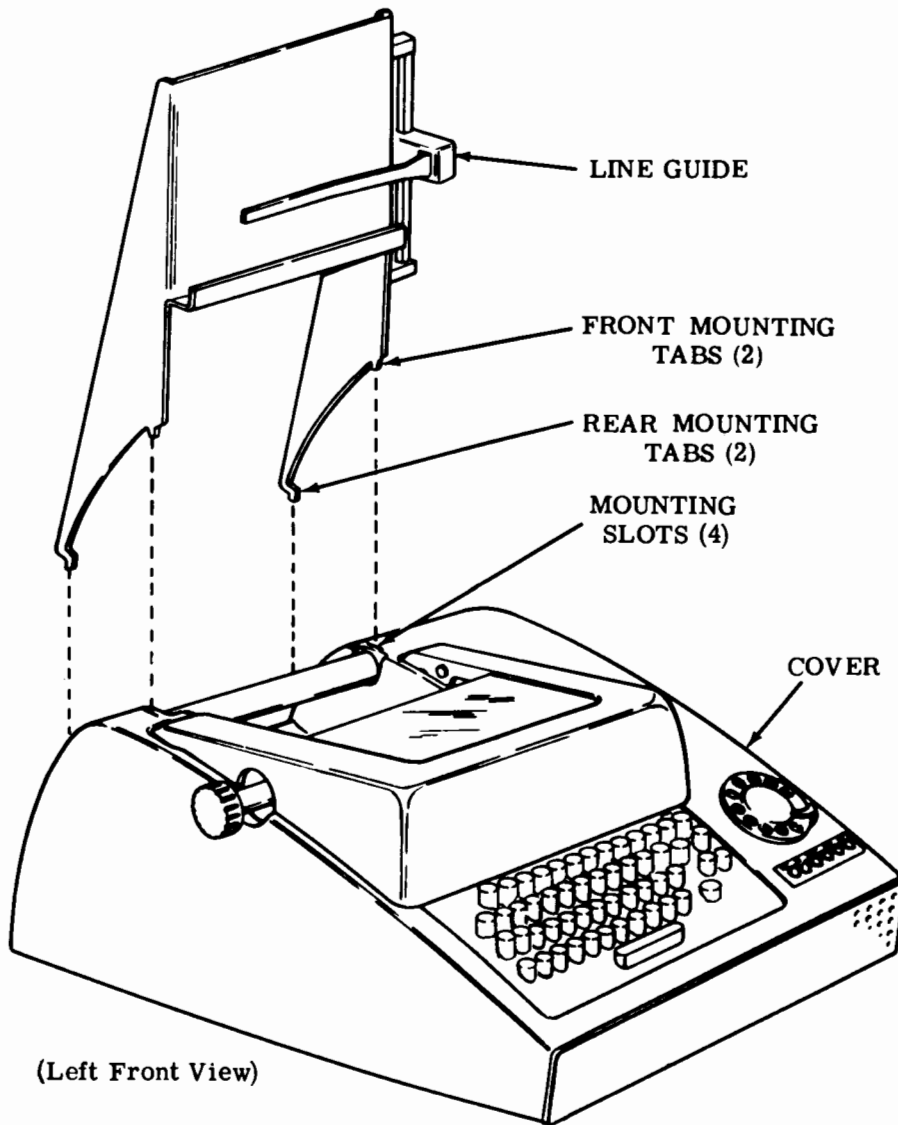

Figure 20 - Copyholder

33 TELETYPEWRITER SET

REMOVAL AND REPLACEMENT OF COMPONENTS

CONTENTS	PAGE
1. GENERAL	1
2. REMOVAL AND REPLACEMENT . . .	1
COVER	1
TYPING UNIT	2
KEYBOARD	4
CALL CONTROL UNIT	4
TAPE READER	5
PUNCH	5

1. GENERAL

1.01 This section provides removal and replacement of components for the 33 Teletypewriter Set. It is reissued to consolidate set information. Marginal arrows have not been used to indicate the change.

1.02 References to left, right, front, rear, etc, consider the set as viewed from the normal operating position.

1.03 The removal procedure given in this section subdivides the set into its major components. Each removal procedure is written assuming the set to be completely assembled, that is, no components previously removed. If further disassembly of the component is required, refer to the appropriate disassembly and reassembly section or the illustrated parts section which gives detailed arrangements of all parts. Where it will help in determining their location, the numbers of the parts are given in the instructions.

1.04 All tools used to remove the major components referred to in this section can be found in the 570-005-800TC standard tool section.

1.05 Any damaged, worn, or distorted parts should be replaced if encountered in the removal and replacement procedure.

CAUTION: BEFORE REMOVING COMPONENTS, REMOVE CONNECTORS FROM EXTERNAL RECEPTACLES (POWER SOURCE, DATA SET, ETC).

2. REMOVAL AND REPLACEMENT

COVER

2.01 To remove the set cover (Figure 1), proceed as follows.

(a) Remove paper and paper roll spindle. Remove bezel, if used, on call control unit by removing screws. Remove the volume control knob, if used, or the power switch rotary knob, if used, by pulling forward. Remove the nameplate by pulling it down and out. Remove the platen knob used on friction feed typing units by pulling it to the left. On sprocket feed typing units, remove a platen knob screw first, then remove the platen knob by pulling it to the left.

(b) Remove the four TP181141 screws from front and the three TP184085 screws from rear of typing unit cover.

Note: On Automatic Send-Receive (ASR) Teletypewriter Sets, remove the TP183112 screw from left rear corner of the tape reader cover.

(c) Gently lift the cover from the subbase and set it aside.

Note: On Automatic Send-Receive (ASR) Teletypewriter Sets, the typing unit cover, tape punch cover, and reader cover are all interconnected and they remove as one unit. If desired the three covers can then be separated from each other.

(d) To replace the cover on sets with low paper alarm switch, first replace the paper and paper roll spindle. Then reverse the procedure used to remove it. Make sure all protrusions are aligned in the holes provided.

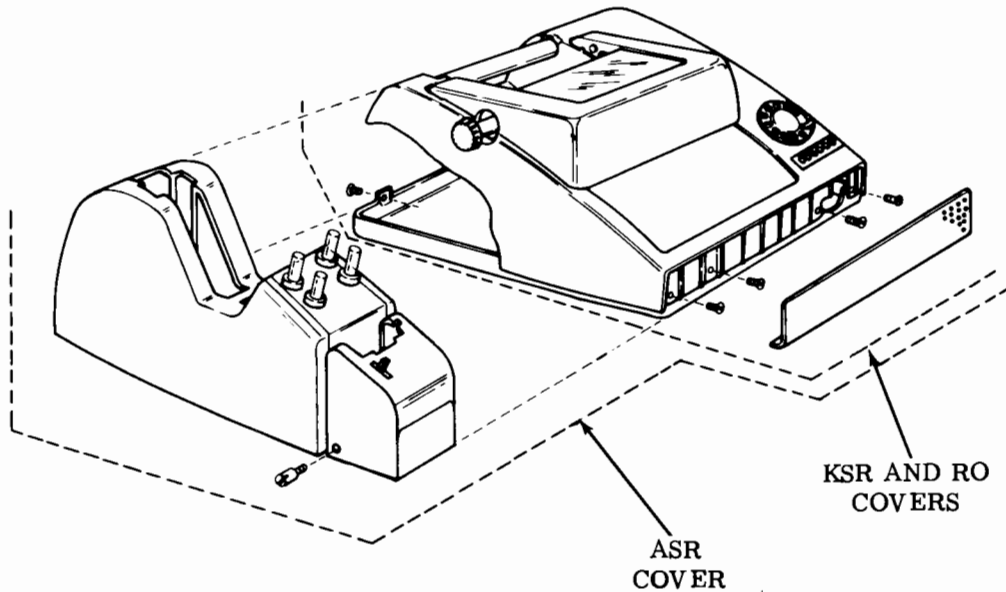

Figure 1 - Set Covers

TYPING UNIT

Note: Sets equipped with the keyboard lock modification kit must have the keyboard removed from the base before the typing unit can be disassembled.

2.02 To remove typing unit (Figure 2), proceed as follows.

- (a) Remove cover assembly as described in 2.01.
- (b) Remove all plugs which connect the typing unit to the call control unit. Remove ground strap from ground tab on call control unit.

Note: On ASR Sets, remove the two leads that connect to the reader cable from the contact assembly.

- (c) Insert screwdriver in slot of TP180977 H-plate and push to left against pressure of spring until plate is disengaged from universal lever. Remove H-plate. (See Figure 2)

- (d) Lift typing unit from subbase using the following procedure.

- (1) Insert a screwdriver between the typing unit base casting and the subbase in the left rear of the typing unit.
- (2) Using the screwdriver as a lever, lift the left rear section of the typing unit until the left hand can be placed under the unit.
- (3) Grasp the extreme right side of the front carriage shaft and lift the typing unit from the subbase.

- (e) To replace typing unit, reverse procedure used to remove it. Make sure typing unit is properly seated on rubber isolators and TP180831 answer-back bellcrank is under and aligned with HERE IS key. Replace plugs in proper receptacles on call control unit. Replace H-plate.

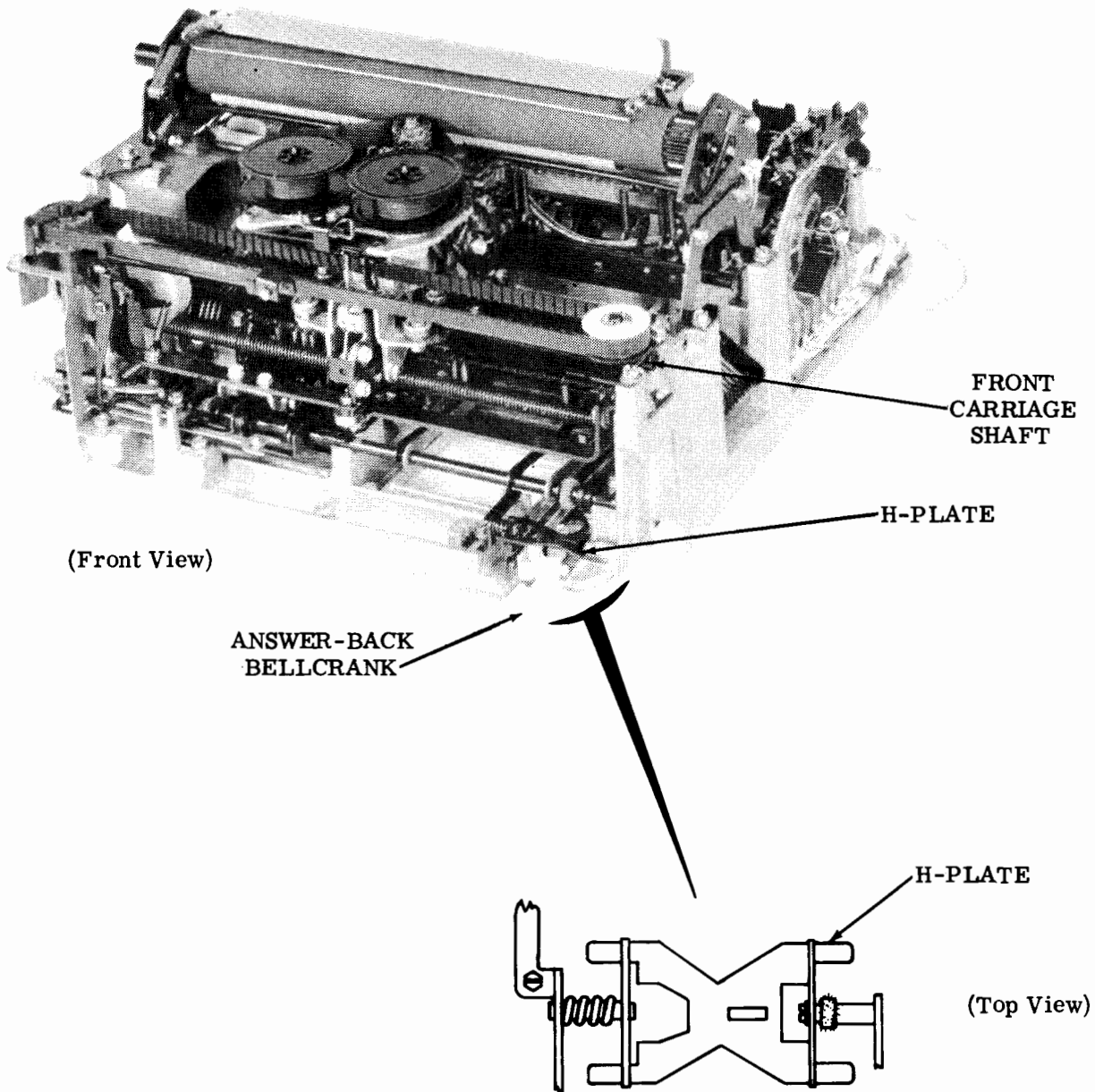

Figure 2 - Typing Unit

KEYBOARD

2.03 To remove the keyboard (Figure 3), proceed as follows.

- (a) Remove cover assembly as described in 2.01.
- (b) Remove the keyboard plug from its receptacle on the call control unit.
- (c) Move the call control unit aside after removing the four TP121551 mounting screws.
- (d) Disengage the keyboard cable from the TP182531 cable clips on subbase.
- (e) Insert a screwdriver in slot of TP180977 H-plate and push to left against pressure of spring until H-plate is disengaged from the universal lever. Remove the H-plate.
- (f) Loosen the two TP180798 keyboard mounting screws. Slide keyboard assembly toward the rear and lift it from subbase.

(g) To replace keyboard, reverse procedure used to remove it.

CALL CONTROL UNIT

2.04 To remove the call control unit (Figure 3), proceed as follows.

- (a) Remove cover assembly as described in 2.01.
- Note: If a speaker is used in conjunction with the call control unit, lift it off the subbase and set it with the call control unit.
- (b) Remove all plugs from rear of call control unit.
- (c) Remove the four TP121551 mounting screws.
- (d) Remove ground strap.
- (e) Remove the call control unit.
- (f) To replace the call control unit, reverse the procedure used to remove it.

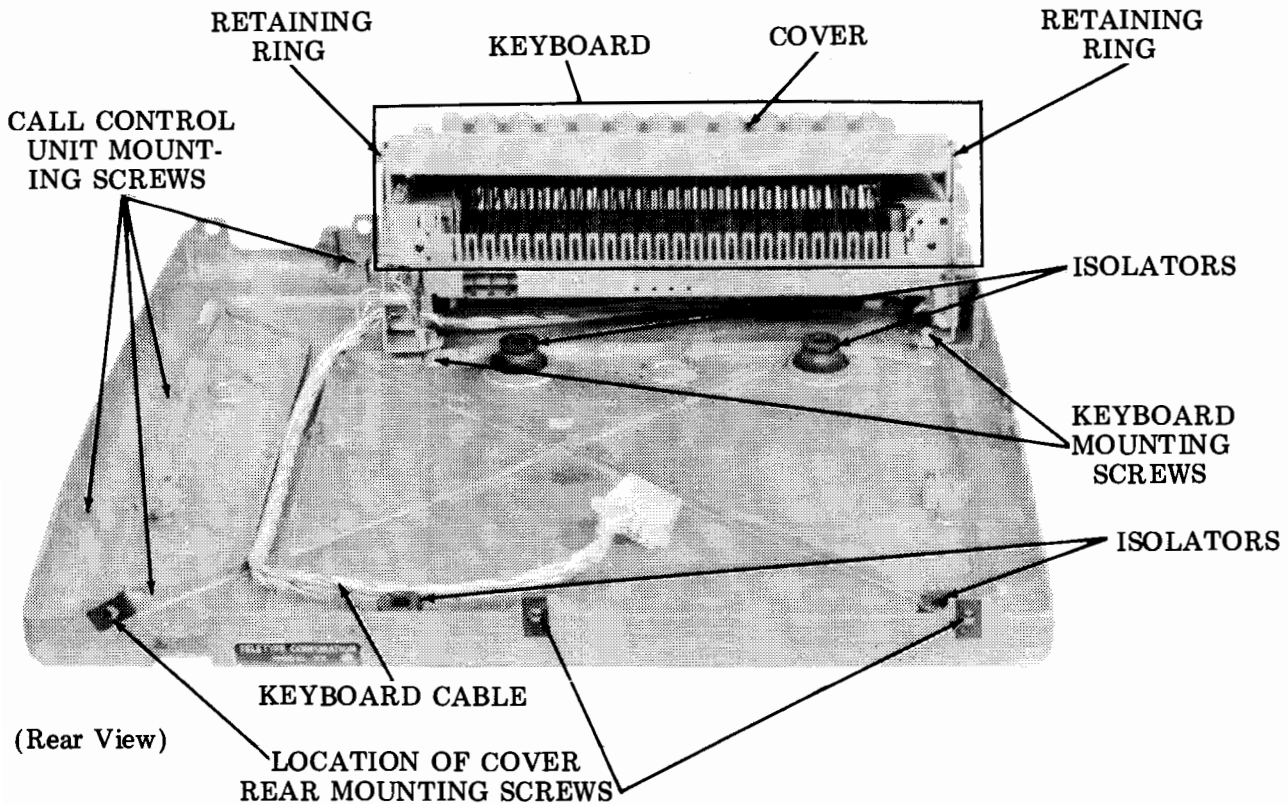

Figure 3 - Subbase With Keyboard

CAUTION: BE SURE THAT THE SPEAKER WIRES DO NOT BECOME ENTANGLED WITH THE BELL RINGER ADJUSTMENT LEVER.

TAPE READER

2.05 To remove the tape reader and attached cable assembly, proceed as follows.

- (a) Remove cover assembly as described in 2.01.
- (b) Remove tape reader plug marked "6" from receptacle in back of call control unit.

Note: On units with automatic reader control, also remove plug marked "5".
- (c) Remove plug from power pack.
- (d) Remove the two TP182726 push-on terminals from the tabs of the tape reader feed magnet contact assembly.
- (e) Remove any necessary cable clamps.
- (f) Remove the four TP121551 call control bracket mounting screws.
- (g) Lift call control unit and remove tape reader cable which is located under the call control unit.
- (h) Replace call control unit.

Note 1: Early Design Tape Readers: Remove the three TP181244 mounting screws, TP7002 flat washers, and TP124177 lock-washers from tape reader mounting bracket.

Note 2: Late Design Tape Readers: First remove the TP119651 retaining ring from the TP183117 locking screw on tape readers so equipped. Then, remove the TP183117 locking screw from tape reader mounting bracket.

PUNCH

2.06 Early Design (Aluminum Casting): To remove the tape punch from the typing unit base casting (Figure 4), proceed as follows.

- (a) Remove cover assembly as described in 2.01.

- (b) Unhook the TP3864 spring from the TP182894 drive link and rotate drive link out of the way.

- (c) Remove the three screws which secure the tape punch base casting to the typing unit base casting in the following order:

First, the TP181246 screw.

Second, the rear TP182891.

Finally, the most forward TP182891 screw.

- (d) Remove the TP182805 nut plate from the inside surface of the front wall of the typing unit base casting.

- (e) Remove the codebar extensions from their respective codebar slots while removing the tape punch base casting from the carriage shaft.

- (f) To replace the tape punch to the typing unit base casting, reverse the procedure used to remove it. Prior to replacing the tape punch to the left side of the typing unit base casting, manually set up the typing unit so that all codebars are in the marking position.

2.07 Late Design (Sheet Steel Frame): To remove the tape punch from the typing unit base casting (Figure 5), proceed as follows.

- (a) Remove cover assembly as described in 2.01.

- (b) Unhook the spring from the drive link and rotate drive link out of the way.

- (c) Remove two bracket connecting screws.

- (d) Remove the mounting screw that holds the platen mounting post to the plate.

- (e) Remove the codebar extensions from their respective codebar slots while also removing the tape punch from the typing unit.

- (f) To replace the tape punch to the typing unit base casting, reverse the procedure used to remove it. Prior to replacing the tape punch to the left side of the typing unit base casting, manually set up the typing unit so that all codebars are in the marking position. Make sure the top surfaces of the mounting brackets are parallel to each other.

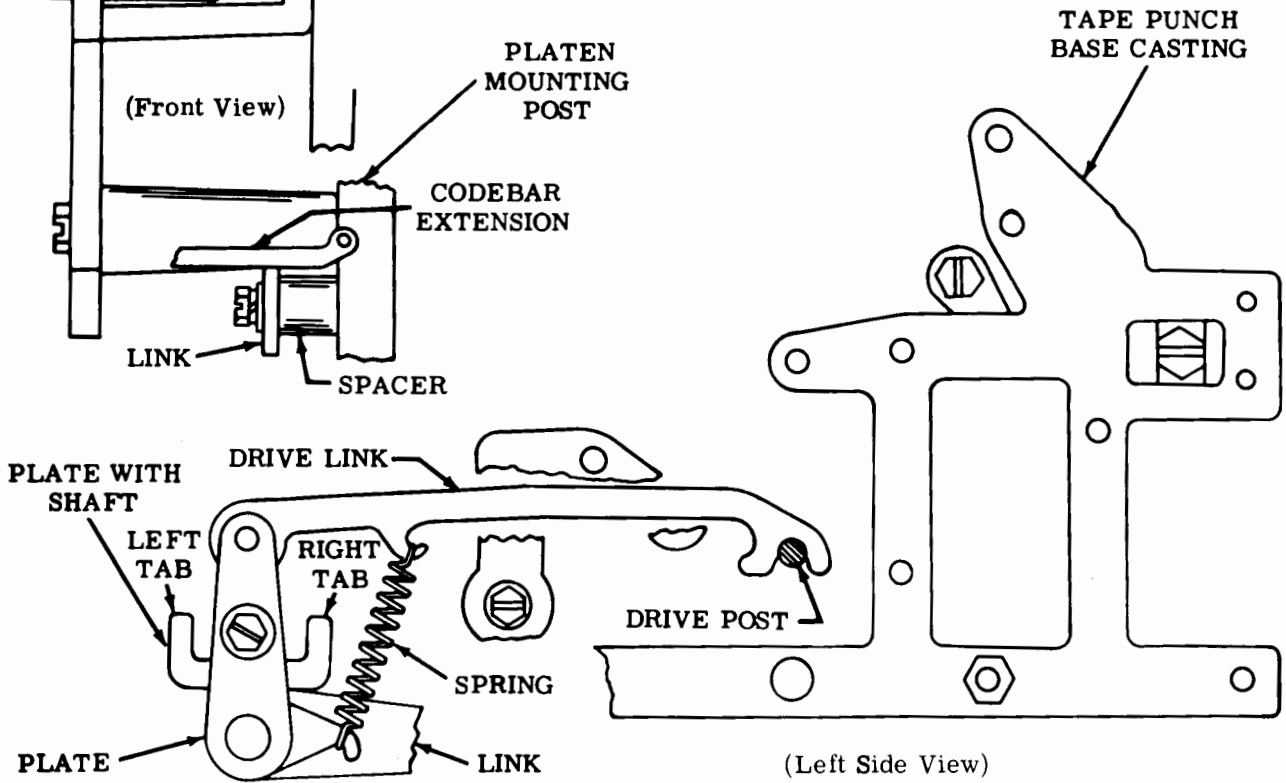
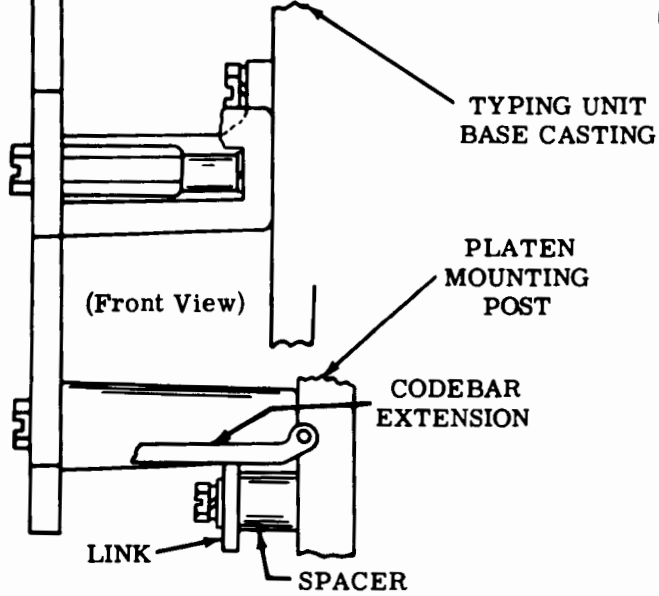
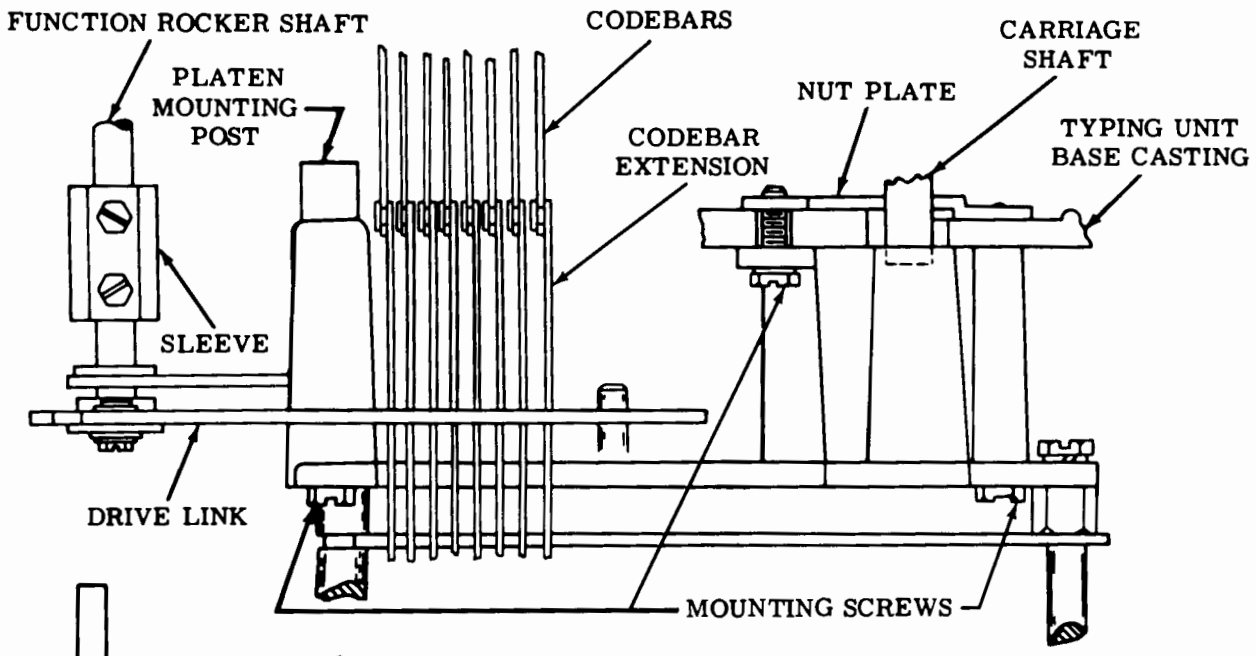

Figure 4 - Tape Punch (Early Design)

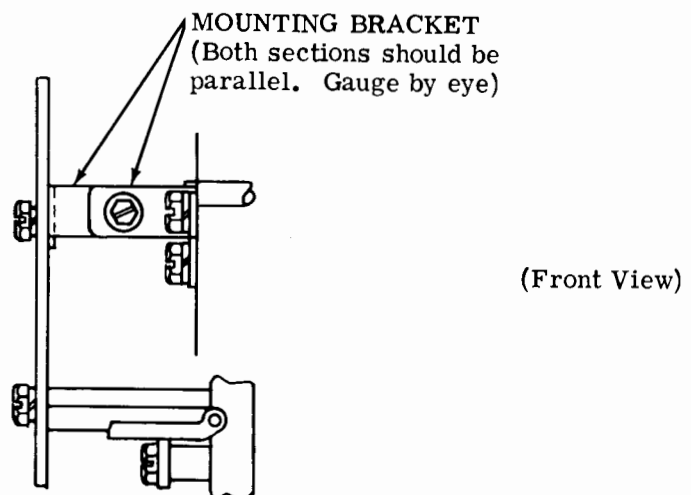
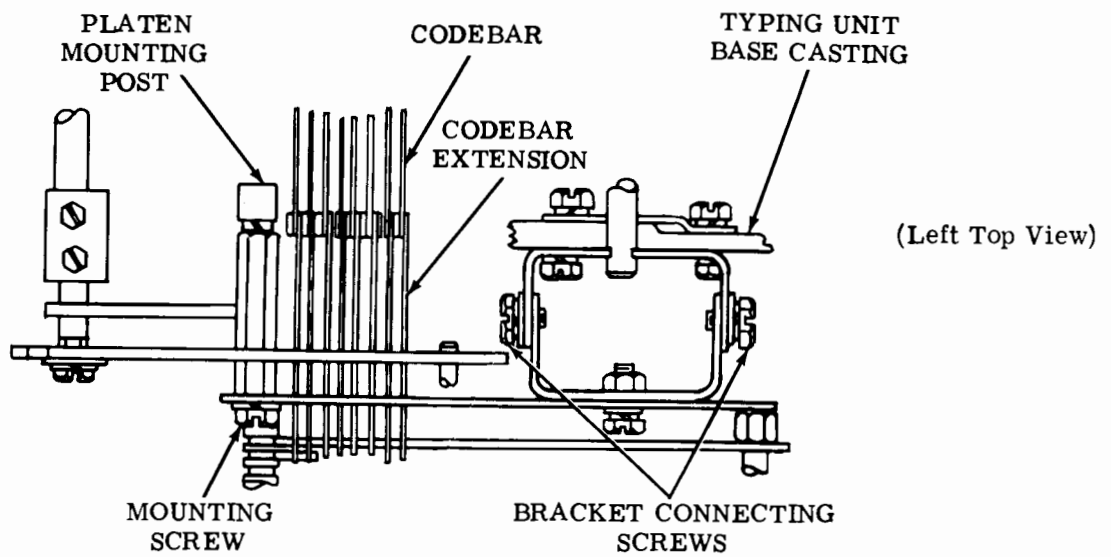
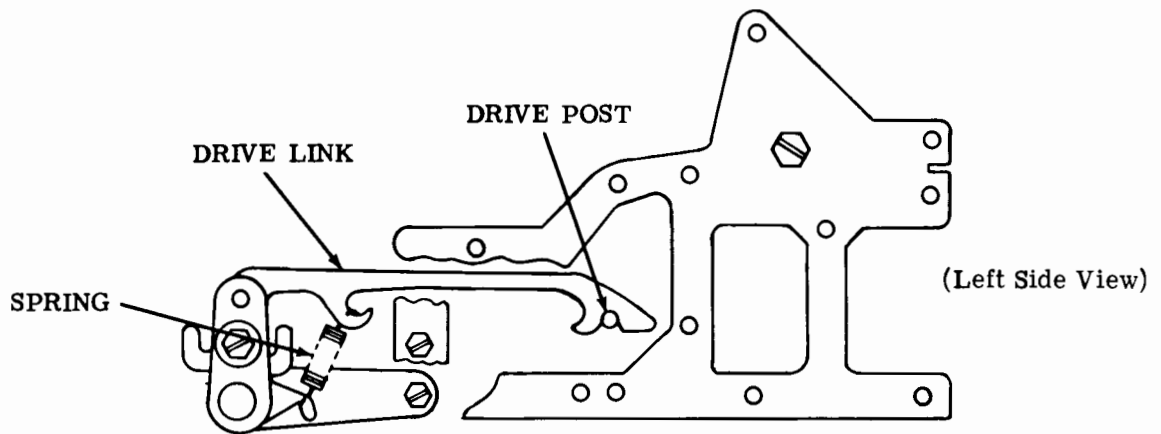

Figure 5 - Tape Punch (Late Design)

33 KEYBOARD

GENERAL DESCRIPTION AND PRINCIPLES OF OPERATION

CONTENTS	PAGE
1. GENERAL	1
2. TECHNICAL DATA	1
3. ASCII	4
4. OUTLINE OF OPERATION	4
5. DETAILED OPERATION	4
A. Codebar Mechanism	4
B. Universal Codebar Mechanism	5
C. Keyboard Contact Mechanism	6
D. Line Break	7
E. Repeat	7
F. HERE IS	7
G. Keyboard — Typing Unit Interface	7
H. Nonparity Operation	7
I. Parity Operation	9
6. KEYBOARDS	12
ALPHANUMERIC KEYBOARD	12
NUMERIC KEYBOARD	12



1.04 The functional difference between the nonparity and parity keyboards is in the control of the eighth level pulse:

- (a) With nonparity keyboards the eighth pulse is always marking.
- (b) With parity keyboards the eighth pulse changes so that an even number of marking pulses is transmitted for every character.

Note: For further details on ASCII and transmission principles, refer to Section 574-122-100TC covering the 33 Typing Unit.

1.05 References to left, right, front, rear, etc, consider the keyboard as viewed by the operator.

1.06 In the illustrations fixed pivots are solid black, and floating pivots — those mounted on parts that move — are crosshatched.

CAUTION: DISCONNECT ALL POWER FROM THE KEYBOARD PRIOR TO INSPECTION.

1. GENERAL

1.01 This section provides general description and principles of operation for the 33 keyboard. It is reissued to consolidate information and update the coding information. Marginal arrows indicate changes and additions.

1.02 Both the nonparity (Figure 1) and parity keyboards (Figure 2) are covered in this section.

1.03 The 33 nonparity and parity keyboards are electromechanical apparatus used to mechanically select and electrically transmit ASCII (American National Standard Code for Information Interchange).

2. TECHNICAL DATA

Note: This equipment is intended to be operated in a room environment within the temperature range of 40°F to 110°F. Serious damage to it could result if this range is exceeded. In this connection, particular caution should be exercised in using acoustical and other enclosures.

2.01 Dimensions and Weight (Approximate)

Height	5 inches
Width12-1/2 inches
Depth	5 inches
Weight4-1/2 pounds

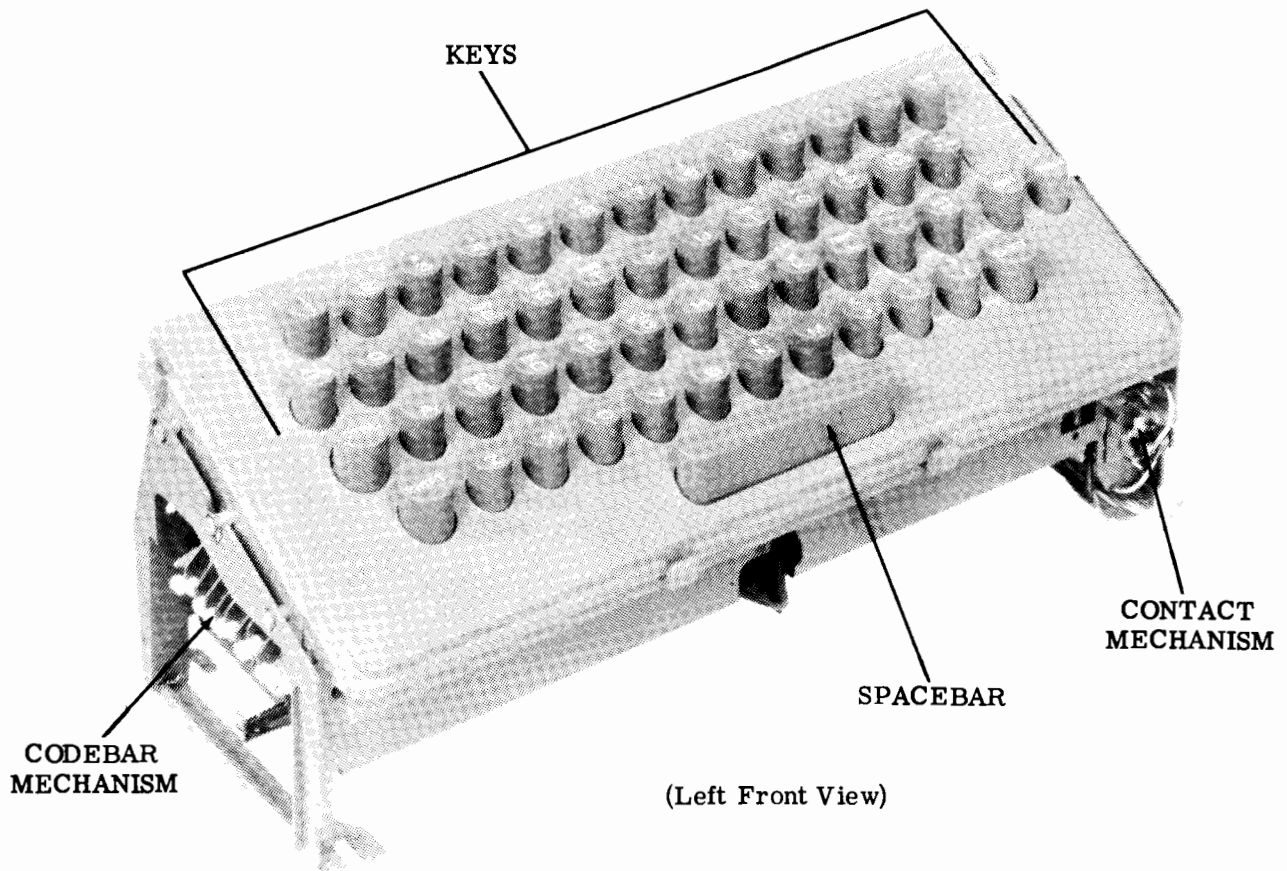

Figure 1 - Nonparity Keyboard

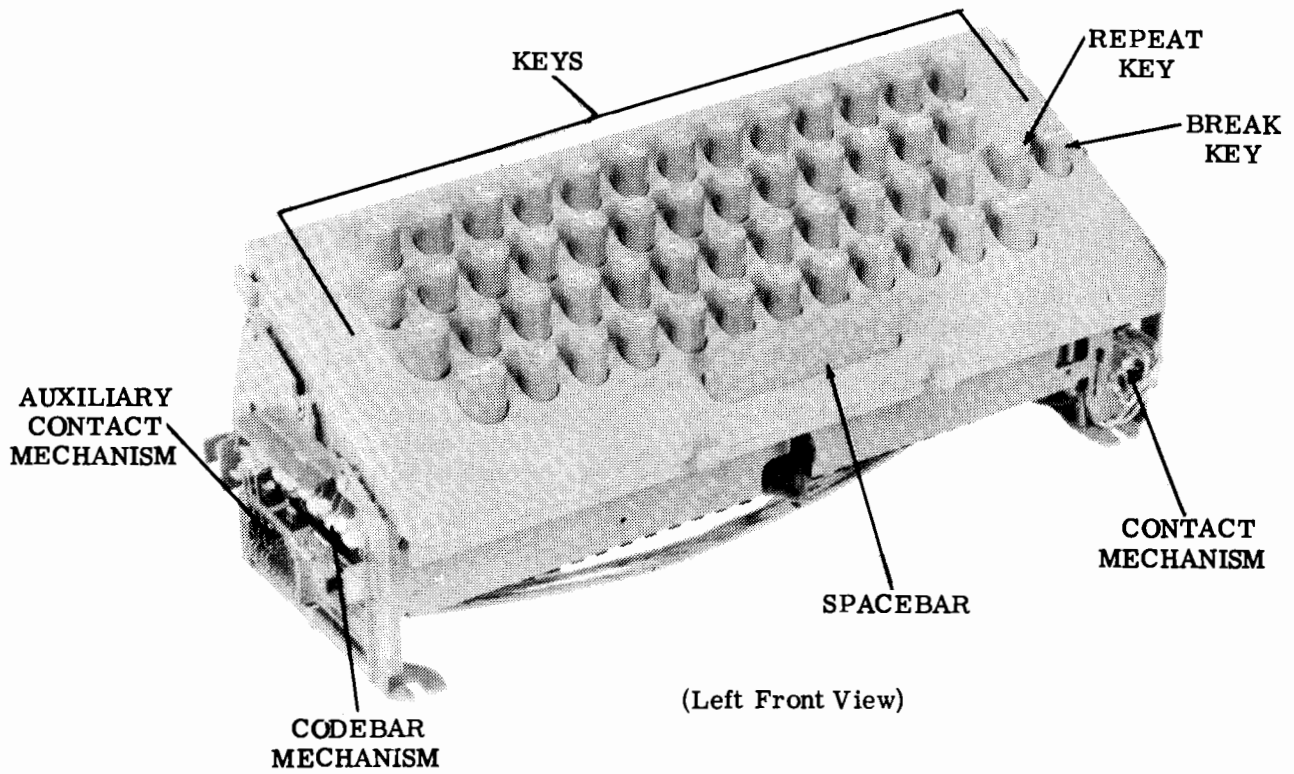
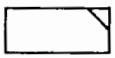
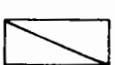

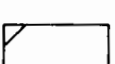



Figure 2 - Parity Keyboard

				b7	0	0	0	0	1	1	1	1		
				b6	0	0	1	1	0	0	1	1		
				b5	0	1	0	1	0	1	0	1		
b4	b3	b2	b1											
0	0	0	0	NUL	DLE	SP	0	@	P	/			Note 5	
0	0	0	1	SOH	DC1	!	1	A	Q					
0	0	1	0	STX	DC2	"	2	B	R	/			Note 5	
0	0	1	1	ETX	DC3	#	3	C	S					
0	1	0	0	EOT	DC4	\$	4	D	T	/			Note 5	
0	1	0	1	ENQ	NAK	%	5	E	U					
0	1	1	0	ACK	SYN	&	6	F	V	/			Note 5	
0	1	1	1	BEL	ETB	/	7	G	W					
1	0	0	0	BS	CAN	(8	H	X	/			Note 5	
1	0	0	1	HT	EM)	9	I	Y					
1	0	1	0	LF	SUB	*	:	J	Z	/			Note 5	
1	0	1	1	VT	ESC Note 6	+	;	K	[
1	1	0	0	FF	FS	,	<	L	\	/			Note 5	
1	1	0	1	CR	GS	-	=	M]					
1	1	1	0	SO	RS	.	>	N	^	/			Note 5	
1	1	1	1	SI	US	/	?	O	—					DEL

- NUL - Null
- SOH - Start of Heading
- STX - Start of Text
- ETX - End of Text
- EOT - End of Transmission
- ENQ - Enquiry
- ACK - Acknowledge
- BEL - Bell
- BS - Backspace
- HT - Horizontal Tabulation
- LF - Line Feed
- VT - Vertical Tabulation
- FF - Form Feed
- CR - Carriage Return
- SO - Shift Out
- SI - Shift In
- DLE - Data Link Escape
- DC - Device Control
- NAK - Negative Acknowledge
- SYN - Synchronous Idle
- ETB - End of Transmission Block
- CAN - Cancel
- EM - End of Medium
- SUB - Substitute
- ESC - Escape
- FS - File Separator
- GS - Group Separator
- RS - Record Separator
- US - Unit Separator
- SP - Space
- DEL - Delete

-  LOCKED OUT BY CONTROL
-  NOT APPLICABLE TO 33 EQUIPMENT
-  SHIFT CHARACTERS
-  CONTROL CHARACTERS
-  LOCKED OUT BY SHIFT

Note 1: 1 = Mark, 0 = Space.

Note 2: Cannot be generated from keyboard.

Note 3: Blocks not indicating SHIFT or CTRL characters contain primary key characters.

Note 4: Filled-in corners or blocks indicate 8th pulse marking (in nonparity units, 8th pulse is always marking).

Note 5: This code can be generated on model 33 nonparity keyboards by depressing the ALT MODE key.

Note 6: The ESC control function may be generated by depressing the ESC key or by simultaneously depressing the K, SHIFT, and CTRL keys.

Note 7: The following keyboard generated control characters are obtained by holding both the CTRL and SHIFT key depressed while operating the specified key once for each character desired:

NUL ... Shift, CTRL - P	GS ... Shift, CTRL - M
ESC ... Shift, CTRL - K	RS ... Shift, CTRL - N
FS ... Shift, CTRL - L	US ... Shift, CTRL - O

Figure 3 - 33 Application of ASCII

2.02 Electrical

Long loops 0.015 to 0.070 ampere,
48 to 240 volts dc inductive

Short loops 0.058 to 0.072 ampere,
(local operation) 16 to 22 volts dc resistive

2.03 Transmission Code

Level 8

3. ASCII

3.01 The 33 keyboard operates according to ASCII. Figure 3 shows the 1968 version of the code used in 33 keyboards. The SHIFT and CONTROL characters, their associated key-top operation lockouts, and parity operation are also illustrated.

4. OUTLINE OF OPERATION

4.01 Transmission of messages is accomplished by an operator selectively depressing the keys and spacebar of the keyboard

in the same manner as in typing. The downward movement of each key or the spacebar is translated by a codebar mechanism into a mechanical arrangement corresponding to the code combination representing the character on the keytop. The mechanical arrangements set up the code combinations in a set of keyboard contacts, and, by parallel output, the code combinations are transmitted to a distributor mechanism. A universal mechanism trips a distributor clutch, and a distributor mechanism then translates the parallel output from the keyboard contacts into corresponding start-stop signal for application to the transmission facilities.

5. DETAILED OPERATION

A. Codebar Mechanism

5.01 The codebar mechanism is illustrated in Figure 4.

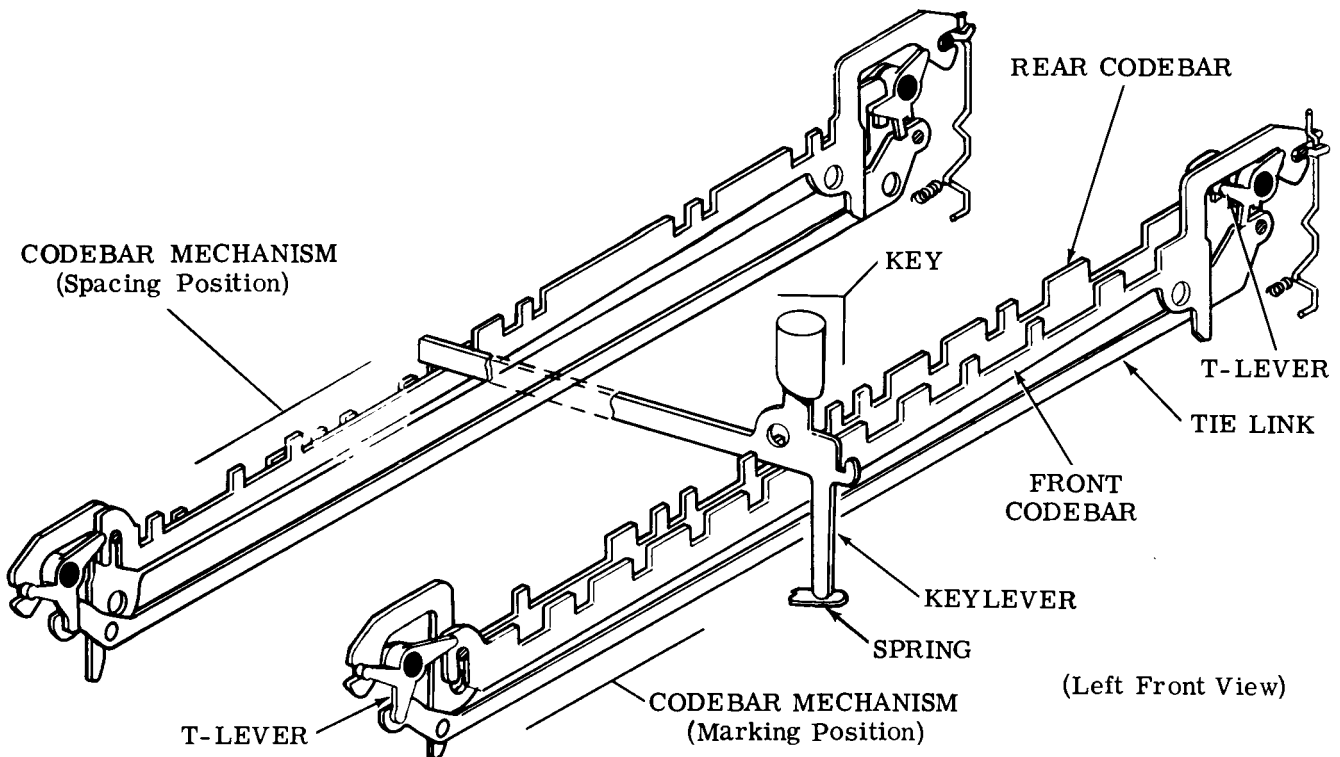

Figure 4 - Codebar Mechanism

5.02 For each level in the code there is a codebar mechanism which consists of a front codebar, a rear codebar, a tie link, and two T-levers. Thus in the 33 keyboard there are 8 pairs of codebars whose function is to set up 8 pairs of contacts in a coded arrangement representing the key depressed. The codebar mechanism also contains a shift mechanism (Figure 8) which consists of a front and rear codebar, a tie link, and two (three in parity keyboards) T-levers. Both the parity and nonparity keyboards contain a control blocking mechanism operated by the CTRL key. It consists of a tie link and two T-levers. The order in which the codebar mechanism is arranged varies, but the following may be considered typical. Thus from front to rear:

Nonparity Keyboard UNIV, 1, SHIFT, 2, 3, 4,
5, 6, 7, CTRL

Parity Keyboard UNIV, 1, 8, 2, 3, 4, 5, 6,
7, SHIFT, CTRL

5.03 The codebars have slots in their top edges which codes them so they are selectively depressed by the keys' keylevers. Each mechanism has a marking and a spacing position. In the marking position, the front codebar is down, the rear codebar is up, and the right T-lever is in the clockwise position. The spacing position is the opposite: front codebar up, rear codebar down, and right T-lever in counterclockwise position.

5.04 The two codebars in each mechanism are coded so that where one has a slot the other is solid. When a character key is depressed, it is returned to its up position by a leaf spring on the underside of the keyboard. However, the code combination set up in the codebars is retained until another key is depressed. When another key is depressed, only the mechanism whose code elements differ from those of the preceding combination are operated.

5.05 As an example assume that the letter E has been transmitted. The E code combination 1-3---78 remains in the codebar mechanisms. Now assume that the I (1--4--78) key is depressed. Its keylever encounters a slot in the rear codebar of the no. 1, 7, and 8 codebar mechanisms. Thus these mechanisms remain marking. In the case of the no. 2, 5, and 6 codebar mechanisms, the keylever encounters a slot in the front codebar, and they remain spacing. In the case of the no. 3 codebar mechanism, the keylever encounters the solid portion of the rear codebar and shifts it to its spacing position.

In a similar manner, the keylever encounters the solid portion of the front codebar of the no. 4 codebar mechanism and shifts it to the marking position.

5.06 Since each code combination is different and is locked in the codebar mechanisms, the complementary coding of the codebars serves as an interlock for the keylevers. When one keylever is depressed, another cannot be depressed because it will be blocked by the solid portion of one or more codebars.

B. Universal Codebar Mechanism

5.07 The universal codebar mechanism is illustrated in Figure 5.

5.08 As a keylever nears the bottom of its travel, it depresses a codebar which is part of the universal codebar mechanism. The codebar, in turn, causes associated T-levers to pivot and a tie link to move to the left. After some free movement, the tie link encounters a tab on a nonrepeat lever and pivots the latter to the left. The tab, in turn, pivots a latchlever which releases a universal lever. Under spring pressure, the universal lever moves up and lifts the nonrepeat lever so that its tab is moved from between the universal tie link and the latchlever. Under spring pressure, the latchlever and nonrepeat lever move back to the right to their unoperated position.

5.09 In its up position, the universal lever locks the right intelligence T-levers in the positions setup by the keylever, permits a contact bail to pivot to its down position and, through a trip linkage, trips the distributor clutch. Near the end of the distributor cycle, the trip linkage moves the universal lever back to its down position where it is latched by the latchlever.

5.10 Should the keylever remain depressed beyond the end of the distributor cycle, when the universal lever moves to its down position, the nonrepeat lever under spring tension moves down until it hangs up on the top of the universal tie link which is still in its left position. When the keylever is finally released, the tie link moves back to the right and permits the nonrepeat lever to move all the way down so that its tab is again between the tie link and the latchlever. The trip mechanism operates in this way to prevent the distributor clutch from being retripped when a keylever is held down.

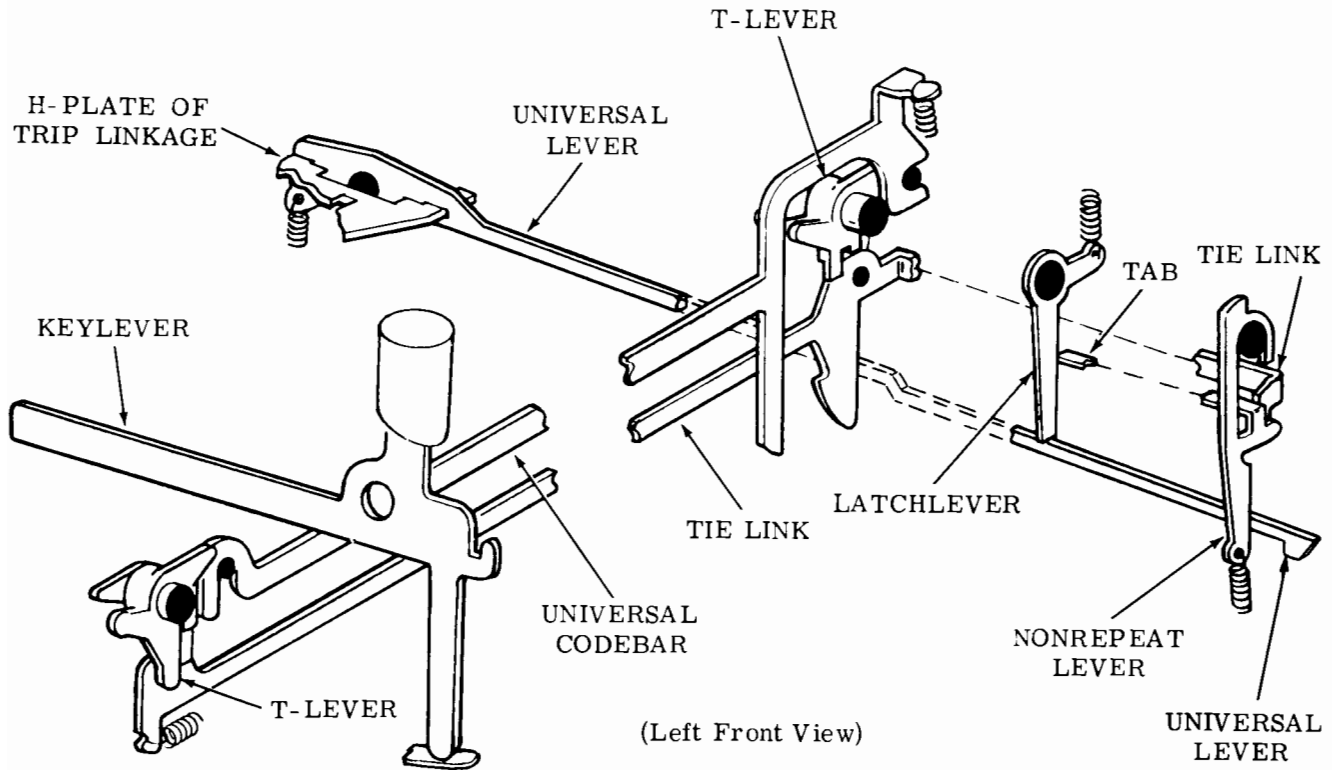

Figure 5 - Universal Codebar Mechanism

C. Keyboard Contact Mechanism

5.11 The keyboard contact mechanism is illustrated in Figure 6.

5.12 The codebar mechanisms set up the code combinations in a set of keyboard contacts. A contact wire is associated with each right T-lever, excluding the universal. In the stop condition of the keyboard, a contact bail is held in its up position by the universal lever. The contact bail holds the contact wires to the right, away from the T-levers.

5.13 When a keylever is depressed, a code combination is set up in the codebar mechanisms. The universal lever moves to its up position and permits the contact bail to pivot under spring tension to its down position. The contact wires associated with the T-levers that are in the marking (clockwise) position are permitted, under spring tension, to move to the left against a common terminal. Those associated with the T-levers that are in the spacing (counterclockwise) position are held to the right

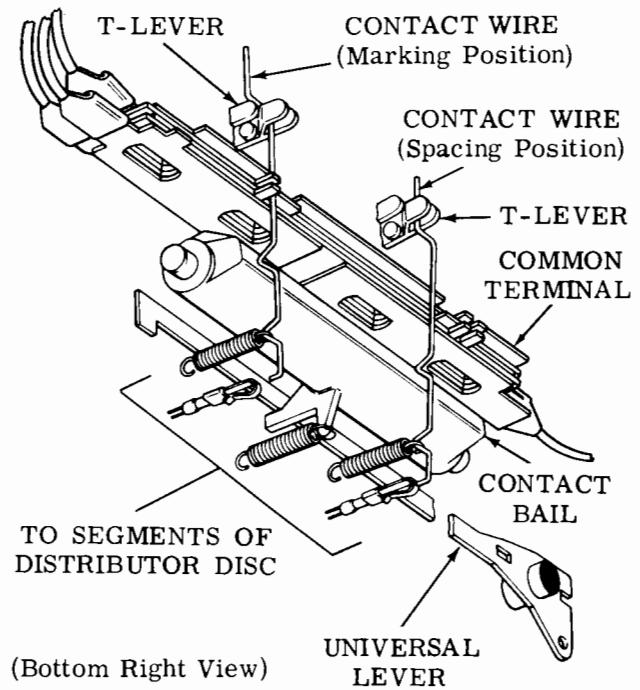

Figure 6 - Keyboard Contact Mechanism

away from the terminal. For example, if the I code combination (1--4--78) is setup in the code-bar mechanism, the no. 1, 4, 7, and 8 contact wires are against the common terminal. Similarly the no. 2, 3, 5, and 6 contact wires are away from the common terminal.

Note: When the universal lever is at the peak of its upward travel, it locks the T-levers in their assumed positions (Figure 7). This eliminates the possible loss of a marking or spacing pulse as a result of blocking T-levers repositioning during keyboard transmission.

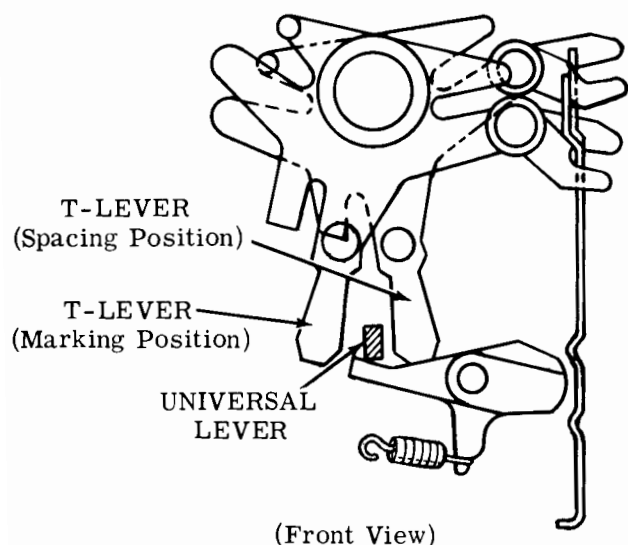

Figure 7 - T-Lever Positioning

5.14 The distributor mechanism converts these positions to start-stop signals. Near the end of the distributor cycle, the universal lever moves back to its down position and pivots the bail to its up position. The bail in turn cams the contact wires back to the right and holds them there in the stop position.

D. Line Break

5.15 When the BREAK key is depressed, it pivots a T-lever which opens the break contact. This action opens the signal line until the BREAK key is released.

E. Repeat

5.16 To repeat the transmission of a character, its keylever is held down along with the REPT keylever. The latter holds the nonrepeat

lever down where its tab remains between the tie link and the latchlever (Figure 5). The latchlever is held in its left position and does not latch the universal lever at the end of the cycle. The universal lever thus moves up and trips the distributor clutch causing the character to be retransmitted as long as the REPT key is depressed.

F. HERE IS

5.17 When the HERE IS key is depressed, its keylever pivots linkages in the typing unit which in turn activate the local answer-back.

G. Keyboard — Typing Unit Interface

5.18 The H-plate (Figure 5) serves as the mechanical interface between the keyboard and the typing unit.

5.19 After a key is depressed and the keyboard contacts are positioned, the universal lever moves to its up position. This upward movement is transferred by the H-plate to the distributor clutch linkage, to trip the distributor clutch. Near the end of the distributor cycle the trip linkage, through the H-plate, resets the universal lever back to its lower position.

H. Nonparity Operation

5.20 Figure 9 is a simplified schematic of the signal wiring for the nonparity keyboard.

5.21 Intelligence transmitted from the nonparity keyboard is that of the ASCII system. The keyboard contains two SHIFT keys and one CTRL (Control) key (Figure 8). The control key, utilizing a tie link and T-levers, operates a contact wire in the contact mechanism. The SHIFT key is used to generate the code combinations for printing characters appearing on the upper keytop (eg \$ above the 4). The CTRL key is used to generate the codes for the nonprinting control characters appearing on the upper keytops (eg EOT above the D). Simultaneous use of both CTRL and SHIFT keys allows access to special control functions, such as NULL. In every case, the SHIFT and/or CTRL keys must be held down while the appropriate character key is depressed.

5.22 The SHIFT key inverts the no. 5 code element on all 33 keyboards. If the element is normally marking, it makes it spacing; if the element is normally spacing, it makes it

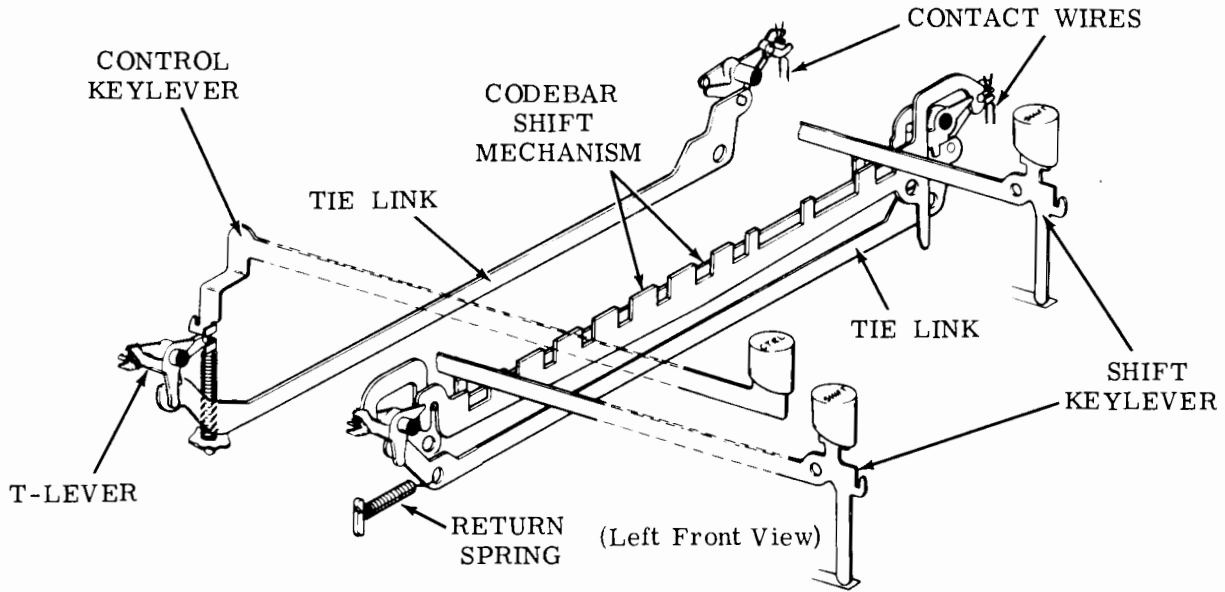
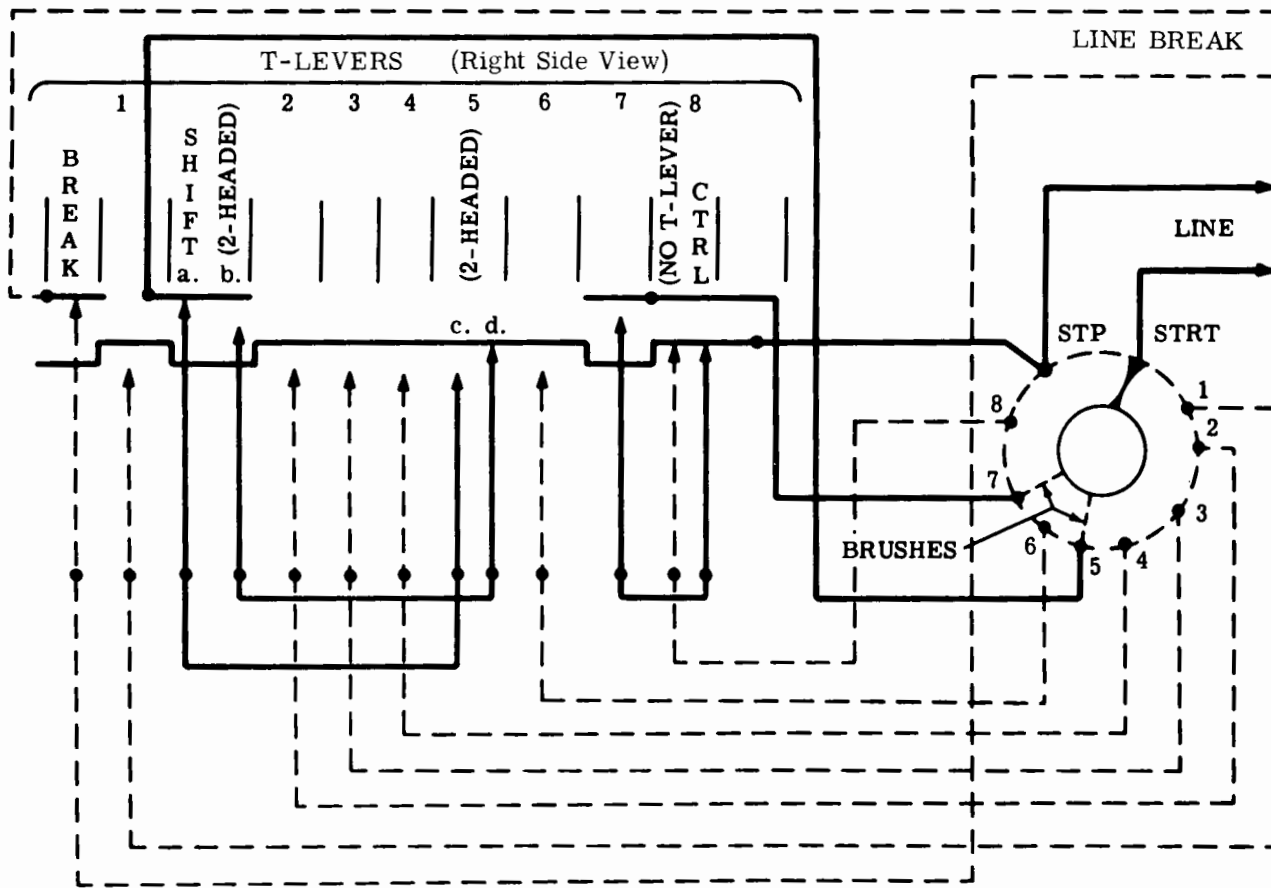

Figure 8 - SHIFT and CTRL Mechanisms — Nonparity Keyboard



Note: Intelligence contacts shown in spacing position.
Shift contacts shown in unoperated position.

Figure 9 - Contact Schematic — Nonparity Keyboard

marking. It does this by two 2-headed T-levers, one at the shift position, and one at the no. 5 position, each of which operates two contact wires, alternately opening one and closing the other. As shown in Figure 9, in the spacing condition, the "c" contact associated with the no. 5 T-lever is open, and the "d" contact is closed. In its unoperated position, the "a" contact associated with the SHIFT T-lever is closed, and the "b" contact is open. For example, if the "4" key alone is depressed, the code combination for "4" (--3-56-8) is set up in the keyboard contacts and subsequently transmitted. In this case, the 2-headed no. 5 T-lever holds the "c" contact closed and the "d" contact open, resulting in a marking no. 5 code element. (The signal path is through the stop distributor disc segment, the common terminal, the closed "c" contact, the closed "a" contact, the no. 5 distributor disc segment, the brushes, the inner distributor disc, and the start distributor disc segment, as shown in Figure 9.)

5.23 If the "4" key is depressed with the SHIFT key, the same condition is set up in the keyboard contacts, except that the 2-headed shift T-lever holds the "a" contact open and the "b" contact closed and thus opens the signal circuit. This results in the no. 5 code element being spacing rather than marking, and the code combination for "\$" (--3--6-8) being transmitted.

5.24 If the "N" key alone is depressed, the code combination for "N" (-234--78) is set by the codebars and subsequently transmitted to the line. In this case, the 2-headed no. 5 T-lever holds the "c" contact open and the "d" contact closed. On the other hand, if the "N" key is depressed with the SHIFT key, the same condition is set up in the keyboard contacts as before, except that the SHIFT key opens the "a" contact and closes the "b" contact and thus closes the signal circuit. This results in the no. 5 code element being marking rather than spacing and the code combination for ^ (-2345-78) being transmitted.

5.25 The CTRL key converts the no. 7 code element from marking to spacing. For example, if the "E" key alone is depressed, the "E" code combination (1-3--78) is set up in the keyboard contacts and subsequently transmitted. (The path of the current for the marking no. 7 code element is through the stop distributor disc segment, the common terminal, the closed control contact, the closed no. 7 contact, the no. 7

distributor disc segment, the brushes, the inner distributor disc, and the start distributor disc segment.) If the "E" key is held down with the CTRL key, the same condition as before is set up in the contacts, except that the control T-lever opens the control contact and thus breaks the signal circuit. This results in the no. 7 code element being spacing and the code combination for "ENQ" (1-3---8) being transmitted.

I. Parity Operation

5.26 The parity keyboard facilities are similar to those of the nonparity keyboard. The functional difference between parity and nonparity keyboards is in the control of the 8th level pulse.

5.27 These differences include the adding of a codebar mechanism to generate binary information for the eighth intelligence element. In addition, the SHIFT key operates an expanded shift codebar mechanism (Figure 10) which operates three 2-headed T-levers, two 2-headed T-levers control contact wires at the contact mechanism, and one 2-headed T-lever controls contact wires at an added auxiliary contact mechanism (Figure 10). Also, the CTRL key directly operates a 2-headed T-lever which controls contact wires at the auxiliary contact mechanism.

5.28 Figure 10 illustrates how the CTRL key acts to mechanically block all keys which normally have the no. 6 code element marking. When the CTRL key is depressed, a tab on the keylever engages the rear codebar of the no. 6 codebar mechanism and forces it into its spacing position. Simultaneously, the front codebar moves up, and the solid portions on it block the keylevers of all characters which normally have their no. 6 code element marking. This blocking action will prevent false characters from being transmitted.

Note: Keyboard lockout (keylever downward travel blocked by codebar mechanism) may occur if SHIFT or CTRL keytops are only partially depressed when the universal codebar mechanism is activated. To clear the lockout, again depress and release the SHIFT or CTRL keytops and, if necessary, also depress and release the specific primary keytop with which the lockout occurred.

5.29 The SHIFT key inverts the no. 5 and no. 8 code elements on the parity keyboard. If either element is normally marking, it makes it

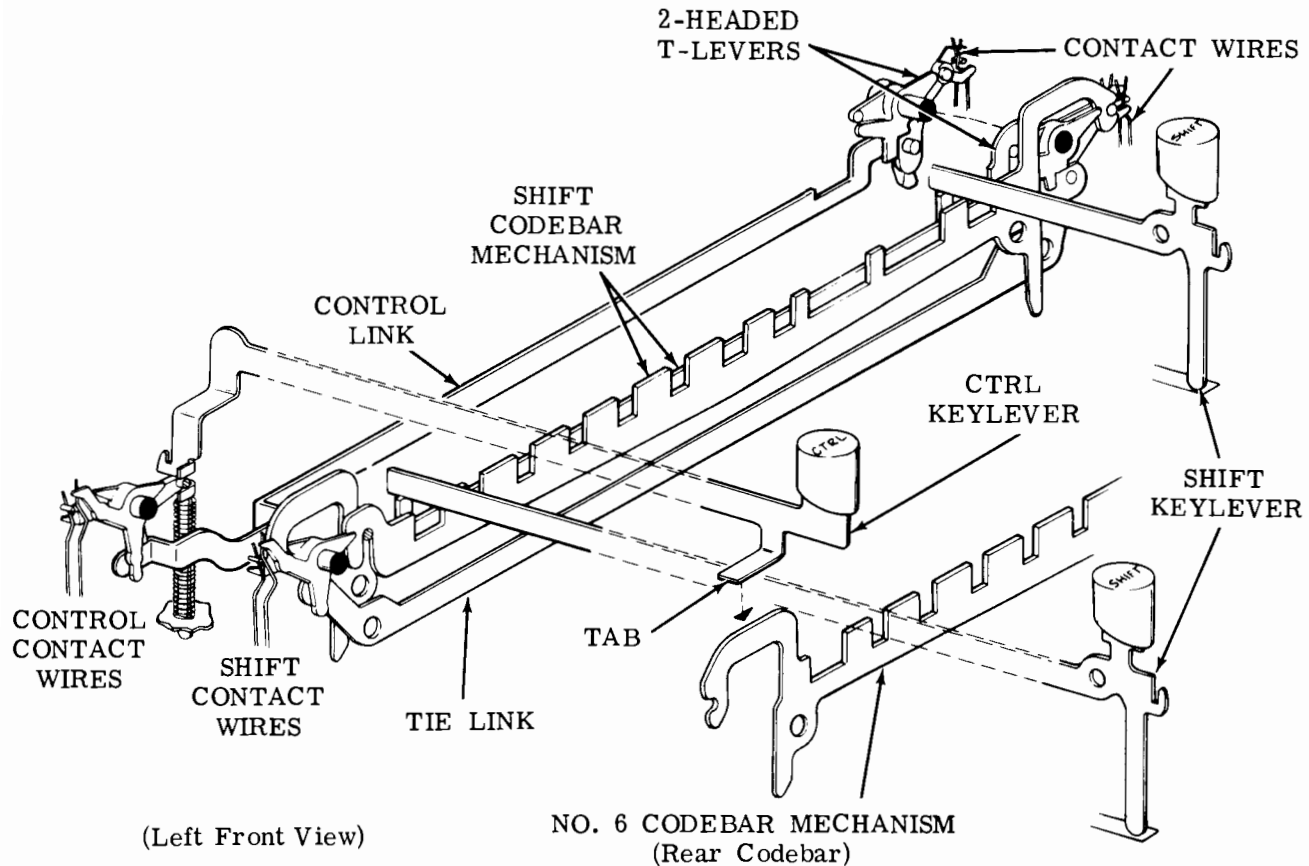
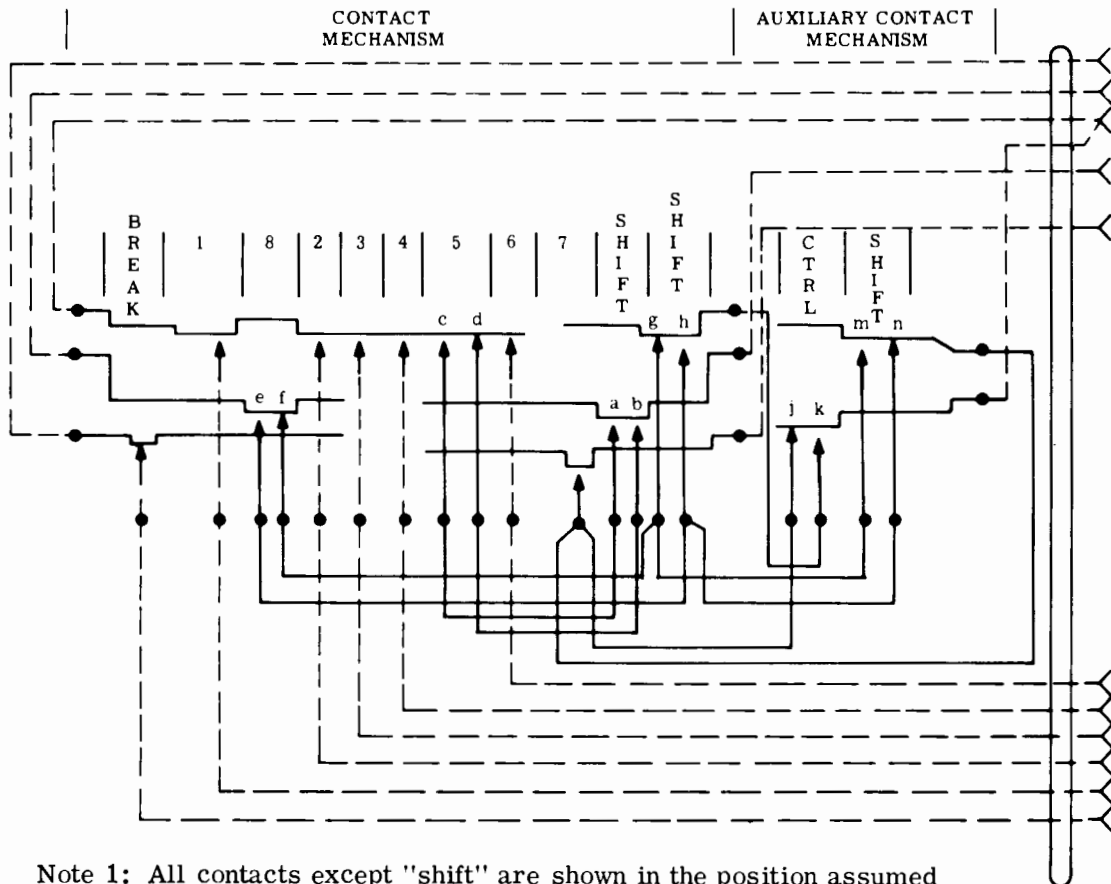

Figure 10 - SHIFT and CTRL Key Operation — Parity Keyboard

spacing; if either element is spacing, it makes it marking. This is accomplished by several 2-headed T-levers — one at the no. 5 position, two at the shift position on the contact mechanism, and one at the shift position on the auxiliary contact mechanism. Each 2-headed T-lever operates two contact wires, alternately opening one and closing the other. As shown in Figure 11 in the spacing condition, the "c" contact associated with the no. 5 T-lever and the "e" contact associated with the no. 8 T-lever are open, and the "d" and "f" contacts, respectively, are closed. In their unoperated positions, with the universal lever latched, the "b", "h", and "m" contacts associated with shift T-levers are open, while the "g" and "n" contacts are closed.

Note: The "a" contact is open on early design units equipped with the TP180043 shift marking contact wires and closed on late design units equipped with the TP186417 marking contact wires.

When the universal lever is tripped and the contact bail is pivoted, the "a" contact will be in the closed condition unless the SHIFT key is depressed, which will open the "a" contact and close the "b" contact. In addition, the "h" and "m" contacts will close and the "g" and "n" contacts will open. For example, if the "4" key alone is depressed, the code combination for "4" (--3-56-8) is set up in the keyboard contacts and subsequently transmitted. In this case, the 2-headed no. 5 T-lever holds the "c" contact closed and the "d" contact open, resulting in a marking no. 5 code element. The current path is from the connector, through the common terminal, the closed "c" contact, the closed "a" contact and terminal, and back to the connector. Since the no. 8 code element is to be marking, the 2-headed no. 8 T-lever holds the "e" contact closed and the "f" contact open. The current path is from the connector, through a terminal and the "e" contact, through the closed "n" contact and terminal, through the closed "j" contact and terminal, and back to the connector.



Note 1: All contacts except "shift" are shown in the position assumed when T-levers are in their counterclockwise position with universal lever latched.

Note 2: The "a" contact is open on early design units equipped with the TP180043 shift marking contact wires and closed on late design units equipped with the TP186417 marking contact wires.

Figure 11 - Contact Schematic — Parity Keyboard

5.30 If the "4" key is depressed with the SHIFT key, the same condition is set up in the keyboard contacts, except 2-headed T-levers hold the "a", "g", and "n" contacts open and the "b", "h", and "m" contacts closed. Thus, the current paths for the no. 5 and no. 8 code elements are open. This results in the no. 5 and no. 8 code elements being spacing rather than marking, and the code combination for \$ (--3--6--) is transmitted.

5.31 If the "N" key alone is depressed, the code combination for "N" (-234--7-) is set up by the codebars and subsequently transmitted to the line. In this case, 2-headed T-levers at the no. 5 and no. 8 positions,

respectively, hold the "c" and "e" contacts open and the "d" and "f" contacts closed. On the other hand, if the "N" key is depressed with the SHIFT key, the same condition is set up in the keyboard contacts as before, except that T-levers associated with the shift position open the "a", "g", and "n" contacts and close the "b", "h", and "m" contacts. Thus current paths for the no. 5 and no. 8 code elements are closed. This results in the no. 5 and no. 8 code elements being marking rather than spacing, and the code combination for ^ (-2345-78) is transmitted.

5.32 The CTRL key converts the no. 7 code elements from marking to spacing and inverts the no. 8 code element. When the CTRL

key is operated, the no. 7 code element will always be spacing. Also, the no. 8 code element will be made spacing if it is normally marking; it will be made marking if it is normally spacing. For example, if the "D" key alone is depressed, the code combination (--3--7-) is set up in the keyboard contacts and subsequently transmitted. The current path for the marking no. 7 code element is from the connector, through the terminal and the closed no. 7 contact, through the closed "j" contact and terminal, and to the connector. Since the no. 8 code element is to be spacing, the 2-headed no. 8 T-lever holds the "e" contact open and the "f" contact closed, and there is no current path. If the "D" key is held down with the CTRL key, the same condition as before is setup in the contacts, except the 2-headed control T-lever opens the "j" contact and closes the "k" contact. This breaks the current path through the no. 7 contact, but closes the path through the "f" contact of the 2-headed no. 8 T-lever. The current path for the no. 8 code element is from the connector, through the terminal and closed "f" contact, through the closed "g" contact and terminal, through the closed "k" contact and terminal, and to the connector. This operation results in the no. 7 code element spacing and the no. 8 code element being marking. Thus, the code combination for "EOT" (--3----8) is transmitted.

6. KEYBOARDS

→ ALPHANUMERIC KEYBOARD

→ 6.01 A typical alphanumeric keyboard arrangement is shown in Figure 12. Keyboards are shipped from the factory with even parity installed. The customer may:

- (a) Retain even parity, or
- (b) Wire the keyboard for the 8th bit always marking, or
- (c) Wire the keyboard for the 8th bit always spacing.

6.02 These wiring options are implemented by connecting wires to terminals at the right front of the keyboard, and at the left contact block. The options and the corresponding wiring are shown in Wiring Diagram 9334WD.

NUMERIC KEYBOARD

6.03 The numeric keyboard is shown in Figure 13. Like the alphanumeric keyboard, the numeric keyboard utilizes the eight level ASCII at 100 words per minute. In some applications the numeric keyboard, when used as

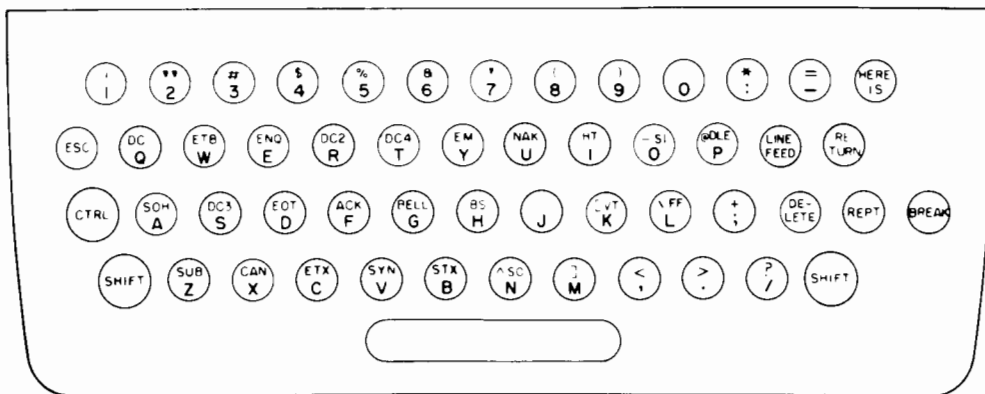

→ Figure 12 - Typical Alphanumeric Keyboard Arrangement

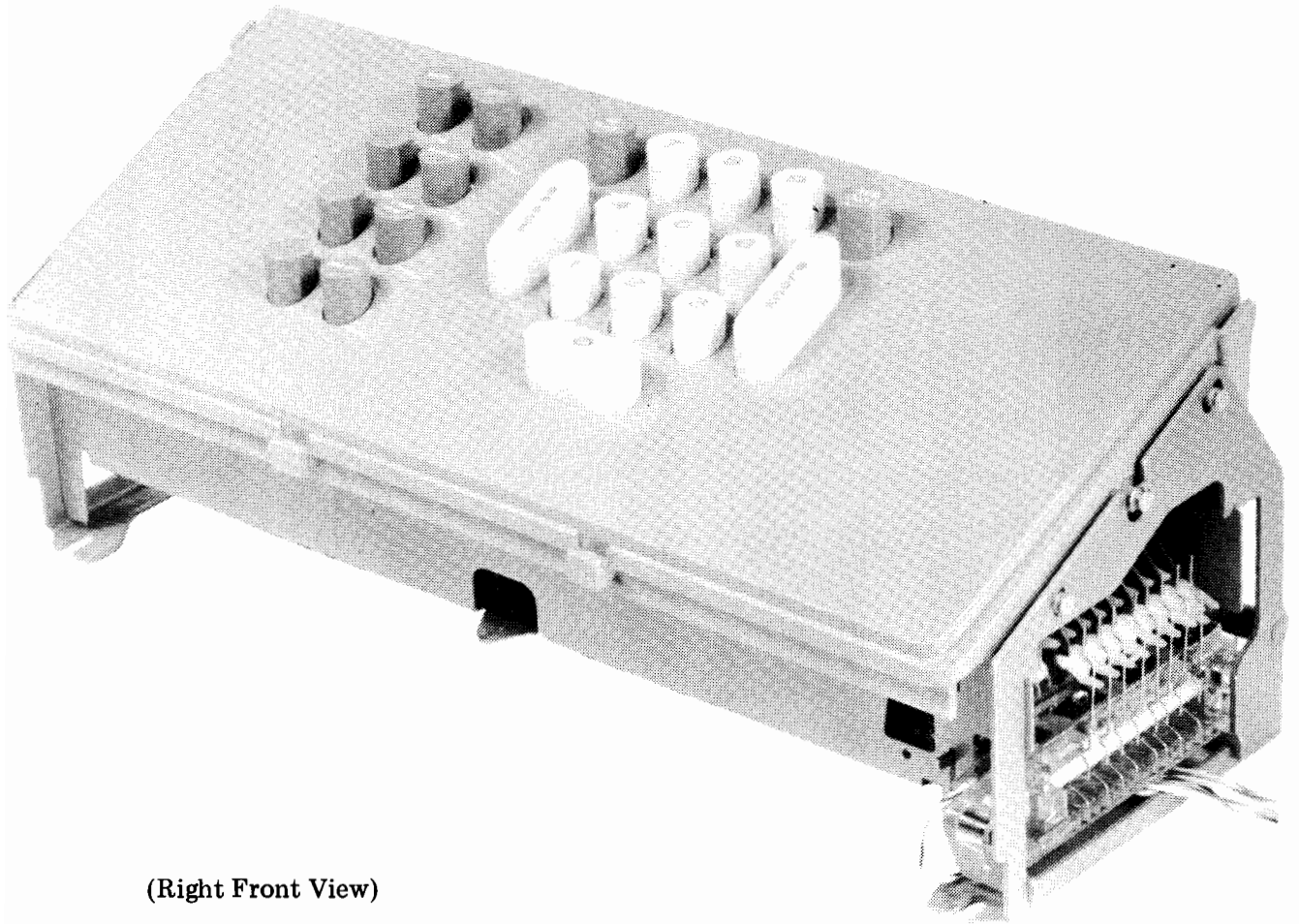

(Right Front View)

Figure 13 - Numeric Keyboard

part of an ASR set, is used for off-line tape perforations of basically numeric information, for use in later transmission.

6.04 Numerics transmitted are 0 through 9; nonprint functions utilized are EOT, SPACE, RUBOUT, RETURN, and LINE FEED. A repeat key is also located on the keyboard. The HERE IS keylever hole has been plugged for optional field installation. On some numeric

keyboards, there is a plugged keylever hole for optional installation of the FORM-FEED keylever; and the codebars are coded for FORM-FEED. Depending on the keyboard, it contains FS, GS, RS, and US keys or variations of these keys.

6.05 The operation of the numeric keyboard is similar to the alphanumeric keyboard as described in Part 5.

33 KEYBOARD
 LUBRICATION

CONTENTS	PAGE
1. GENERAL	1
2. BASIC UNIT	2
Auxiliary contact block	4
Codebar mechanism	5
Contact block	4
CTRL keylever	4
HERE IS, BREAK, and REPT keylevers	3
Keyboard	2
Keylevers	3
Latchlever hooks	5
Locking Mechanism	8
Numeric keyboard (cover removed)	6
Numeric keylevers	7
Reset bail	5
Spacebar	3
SPACE, BLOCK, and O keylevers	7
Universal lever	6

for the tape punch are similar to the lubrication intervals of the set. The lubrication intervals are dictated by the hours of use (including idle time) on a daily basis. The following charts and notes list the appropriate lubrication intervals.

LUBRICATION INTERVALS IN WEEKS
 BASED ON 5-DAY WEEK (Note 1)

NEWLY INSTALLED EQUIPMENT			
DAILY USE			
<u>SPEED</u>	<u>0 TO 8 HOURS</u>	<u>8 TO 16 HOURS</u>	<u>16 TO 24 HOURS</u>
All Speeds	3 Weeks	2 Weeks	1 Week

REGULAR LUBRICATION			
DAILY USE			
<u>SPEED</u>	<u>0 TO 8 HOURS</u>	<u>8 TO 16 HOURS</u>	<u>16 TO 24 HOURS</u>
60 WPM	39 Weeks	26 Weeks	13 Weeks
100 WPM	26 Weeks	13 Weeks	6 Weeks

1. GENERAL

1.01 This section provides lubrication requirements for the 33 keyboard. It is reissued to add new lubrication interval requirements for the keyboard. Marginal arrows indicate changes and additions.

1.02 The general lubrication areas are illustrated by photographs. The specific points to receive lubricant are indicated on line drawings with appropriate textual instructions. The line drawings and textual instructions follow a photograph and are keyed to the photograph by paragraph numbers.

1.03 Thoroughly lubricate the keyboard, but avoid overlubrication that might permit the lubricant to drip or be thrown onto adjacent parts.

1.04 Initial lubrication of the tape punch should be completed just prior to placing it into service. The lubrication intervals

Note 1: Reduce lubrication interval 15 percent when usage is 6 days per week and 30 percent when usage is 7 days per week.

Note 2: Sets operating at speeds between 60 and 100 wpm use lubrication requirements for the lower of the two speeds.

Note 3: The lubrication intervals are for the set as a whole — all components of the set should be lubricated.

Note 4: Just prior to storage all equipment should be thoroughly lubricated.

SECTION 574-121-701TC

1.05 The textual instructions that accompany each line drawing consist of abbreviated directions, specific lubrication points, and parts affected. The meanings of the abbreviated directions (symbols) are given below:

<u>Symbol</u>	<u>Meaning</u>
D	Keep dry — no lubricant permitted.
O	Oil (KS7470).
G	Apply thin coat of grease (KS7471).

1.06 References to left, right, front, or rear, etc, consider the keyboard to be viewed from a position where the spacebar faces up and the contact mechanism is located to the viewer's right.

CAUTION: DO NOT USE ALCOHOL, MINERAL SPIRITS, OR OTHER SOLVENTS TO CLEAN PLASTIC PARTS OR

PARTS WITH PROTECTIVE-DECORATIVE FINISHES. NORMALLY, A SOFT, DRY CLOTH SHOULD BE USED TO REMOVE DUST, OIL, GREASE, OR OTHERWISE CLEAN PARTS OR SUB-ASSEMBLIES. IF NECESSARY, A SOFT CLOTH DAMPENED WITH SOAP OR MILD DETERGENT MAY BE USED. RINSE WITH A SOFT, DAMP CLOTH AND BUFF WITH A SOFT, DRY CLOTH.

1.07 Materials needed for lubrication are listed in Section 570-005-800TC.

1.08 Disassembly and reassembly instructions are given in Section 574-121-702TC.

CAUTION: REMOVE ALL ELECTRICAL POWER FROM UNIT BEFORE LUBRICATION OR DISASSEMBLY.

2. BASIC UNIT

2.01 Keyboard

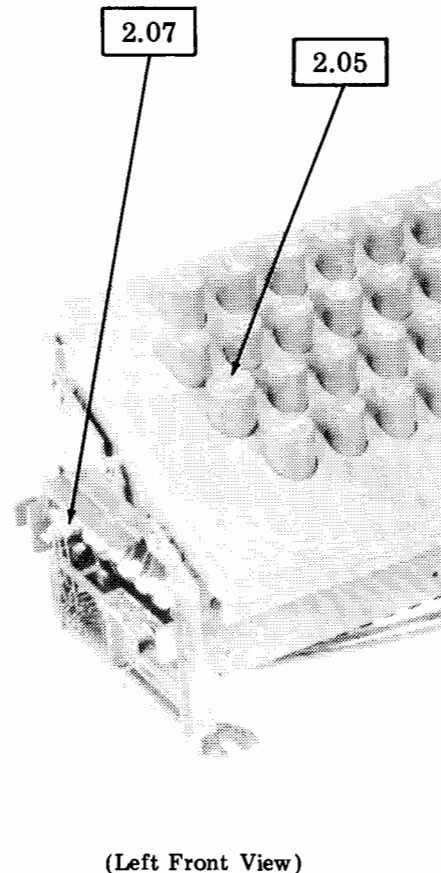
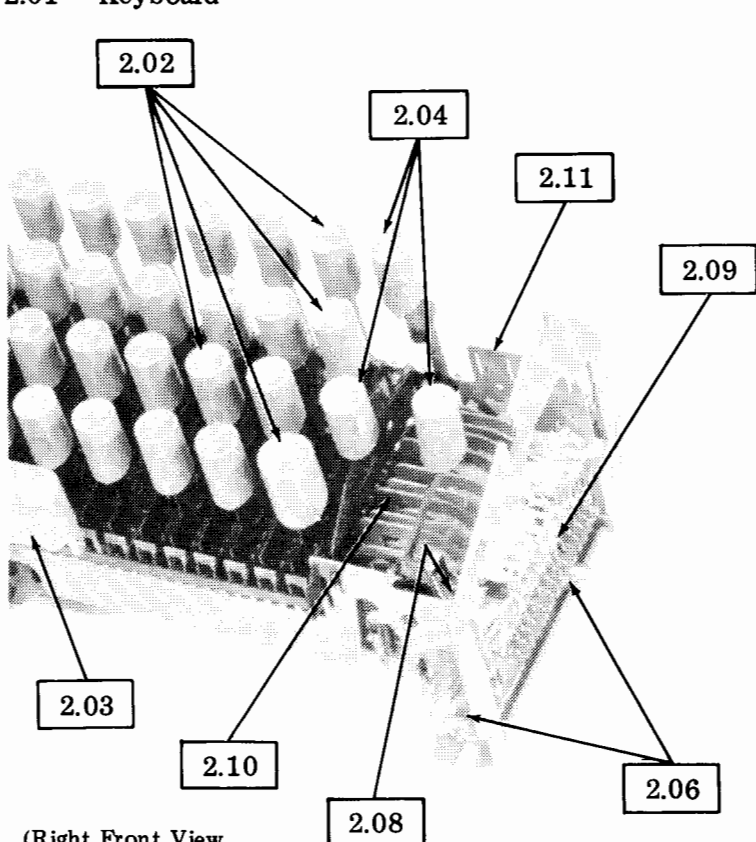

2.02 Keylevers

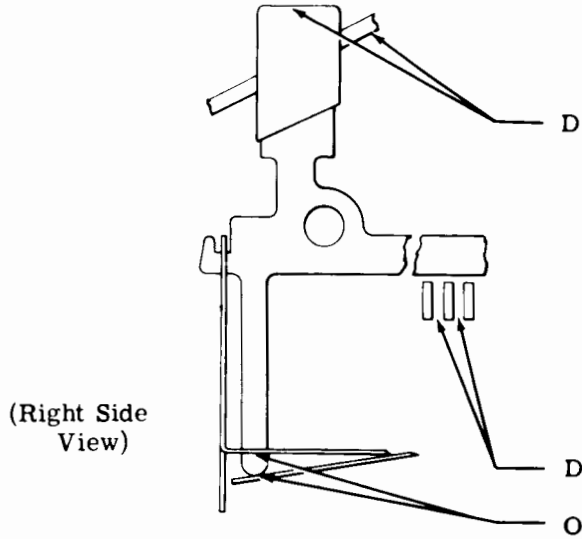

D Top Surface Keytops and Keyboard Cover

D Areas Between Bars Codebars

O Contact Surface Keylever Springs

2.03 Spacebar

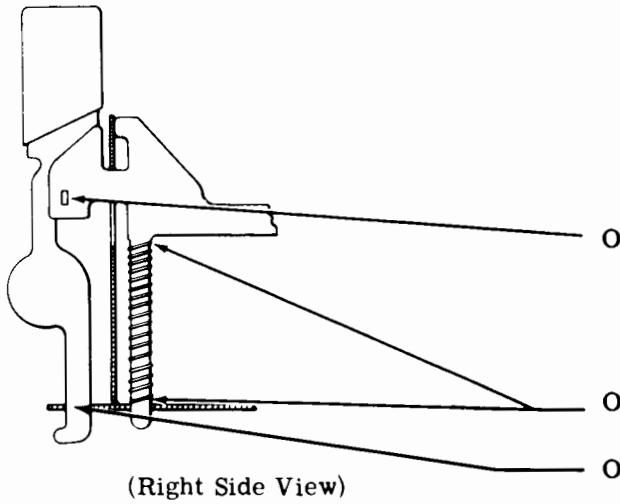

O Contact Surfaces (5) Space Lever

O Seat (Each End) Springs (2)

O Sliding Surfaces Space Lever

2.04 HERE IS, BREAK, and REPT Keylevers

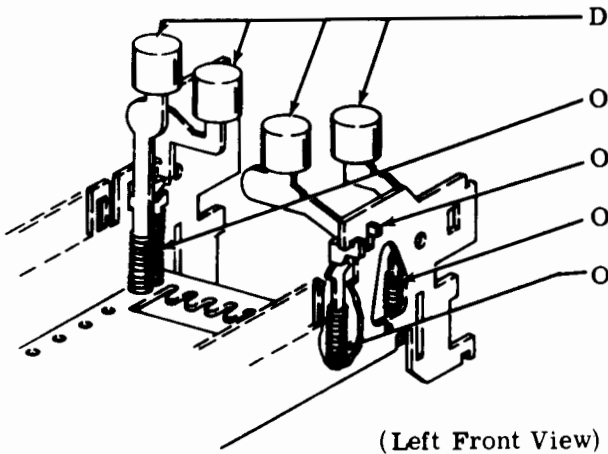

D Top Surface Keytops

O Seat (Each End) Springs

O Contact Surfaces Keylevers

O Seat (Each End) Spring

O Seat (Each End) Spring

2.05 CTRL Keylever

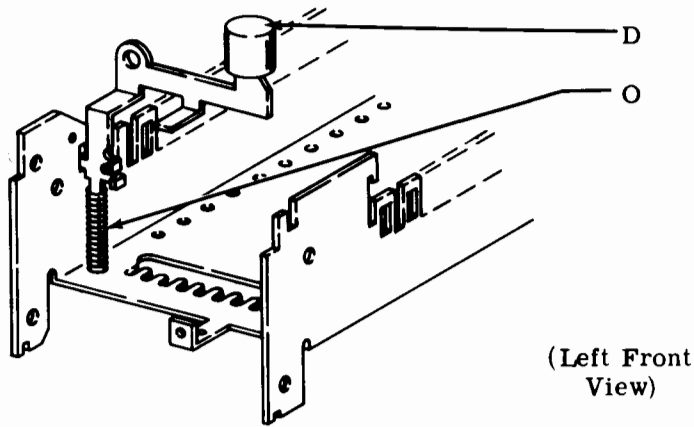

- D Top Surface Keytop
- O Seat (Each End) Spring

(Left Front View)

2.06 Contact Block

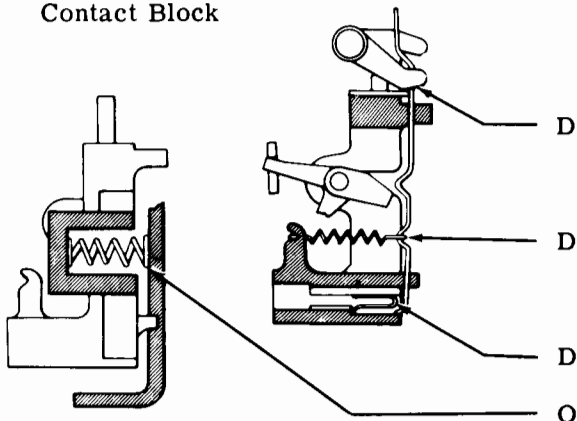

- D Contact Surface Contact Wires
- D Springs Contact Wires
- D Contact Surface Contact Wires
- O Seat Springs (2)

(Front Views)

CAUTION: DO NOT CLEAN THE KEYBOARD CONTACT BLOCK WITH ALCOHOL, MINERAL SPIRITS, OR OTHER SOLVENTS.

2.07 Auxiliary Contact Block

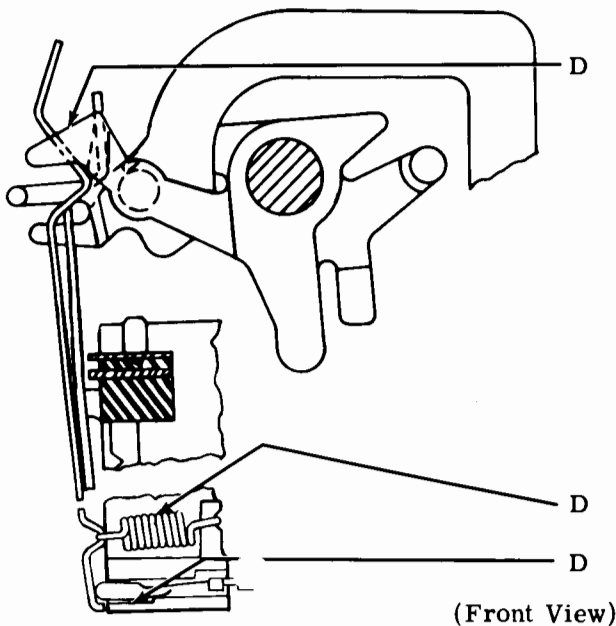

- D Contact Surfaces Contact Wires
- D Springs Contact Wires
- D Contact Surface Contact Wires

(Front View)

2.08 Latchlever Hooks

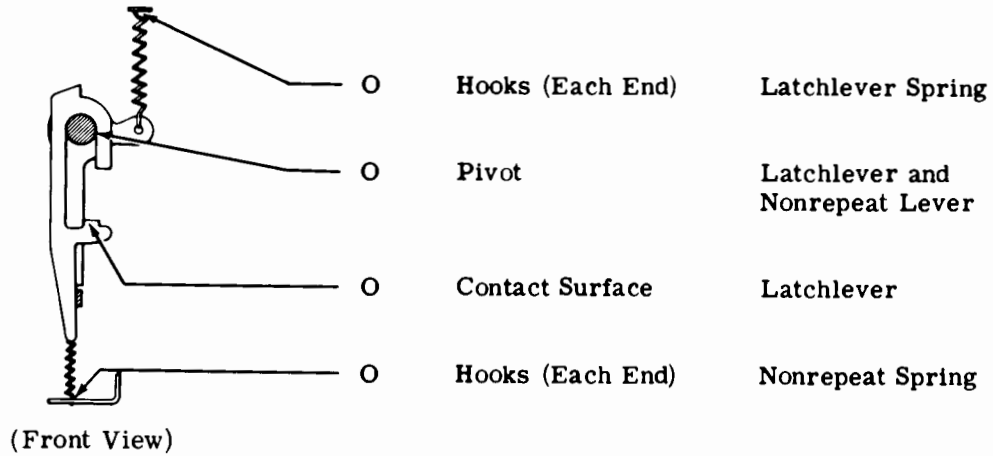

2.09 Reset Bail

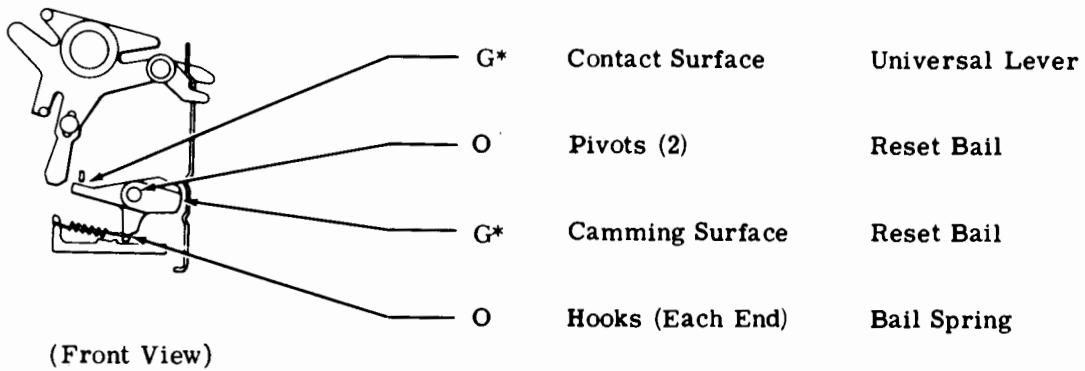

*At 1500 hour lubrication intervals, apply a coat of thoroughly mixed 50 percent KS7470 oil and 50 percent KS7471 grease.

2.10 Codebar Mechanism

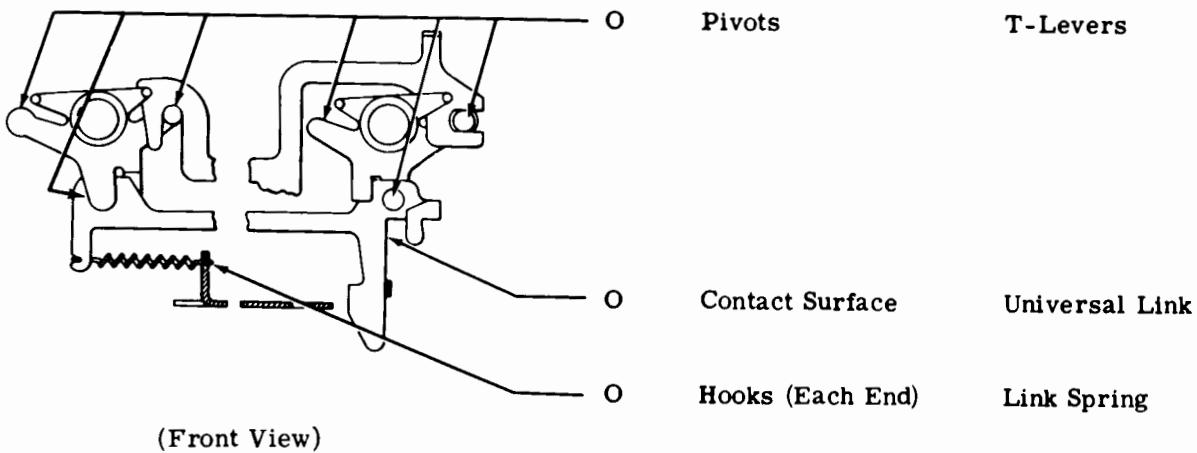

2.11 Universal Lever

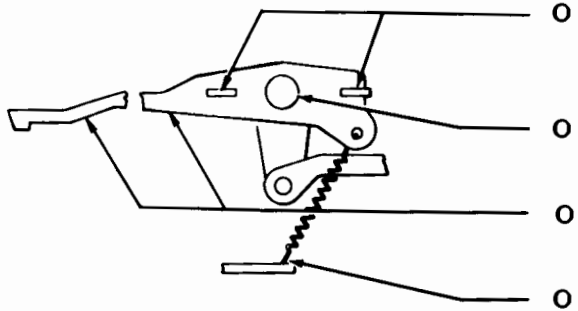

- O Engaging Tabs H-Lever
- O Pivot Universal Lever
- O Engaging Surfaces Universal Lever
- O Hooks (Each End) Spring

(Right Side View)

2.12 Numeric Keyboard (Cover Removed)

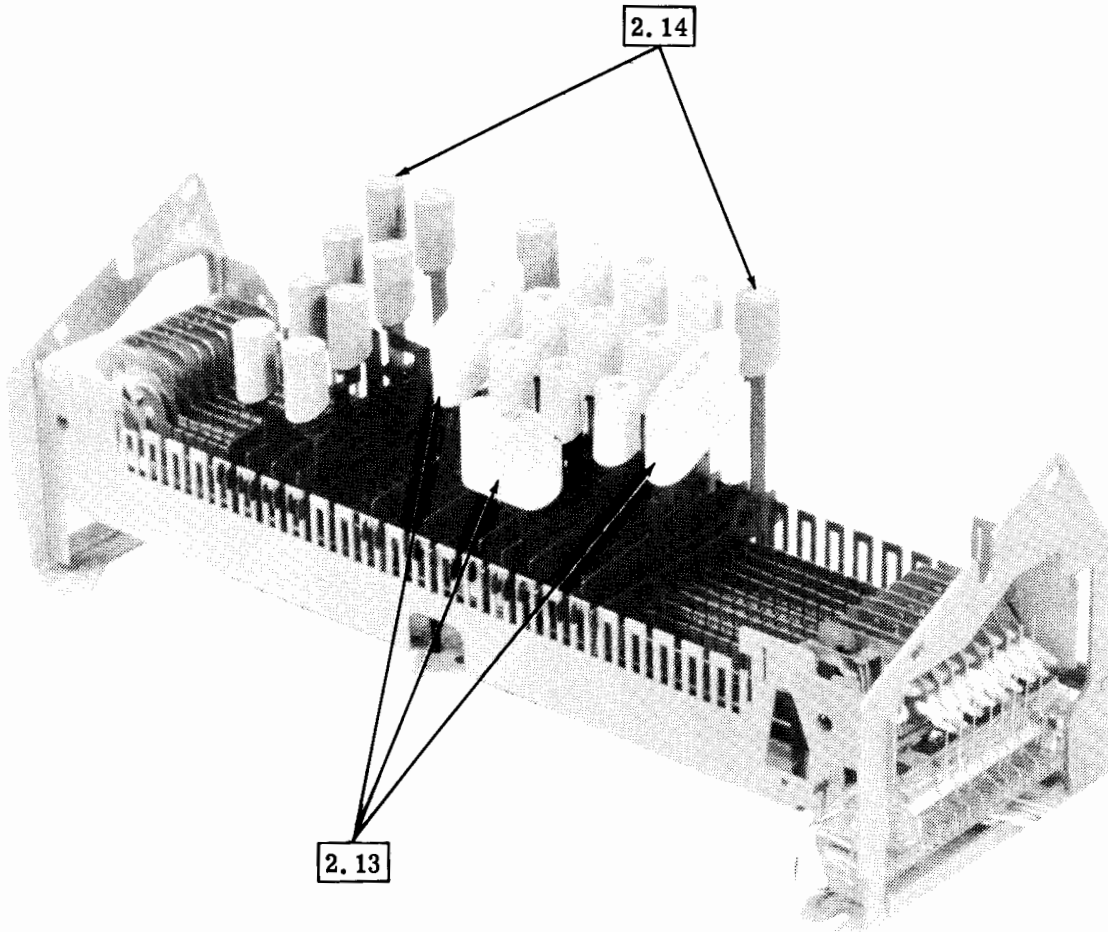

(Right Front View)

2.13 SPACE, BLOCK, and O Keylevers

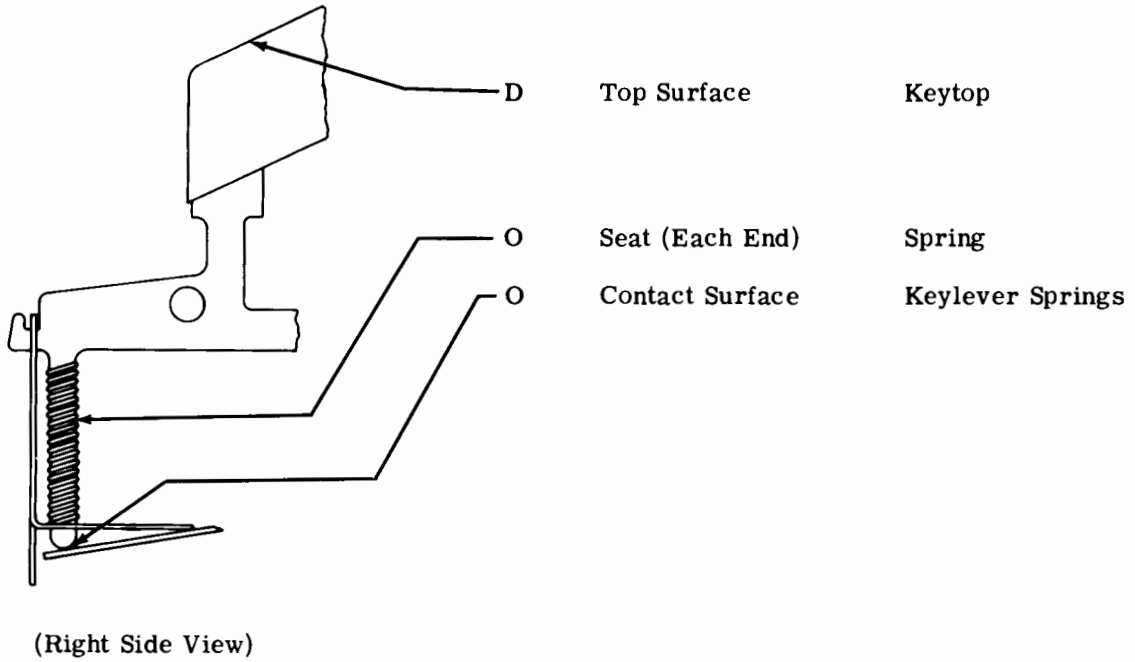

2.14 Numeric Keylevers

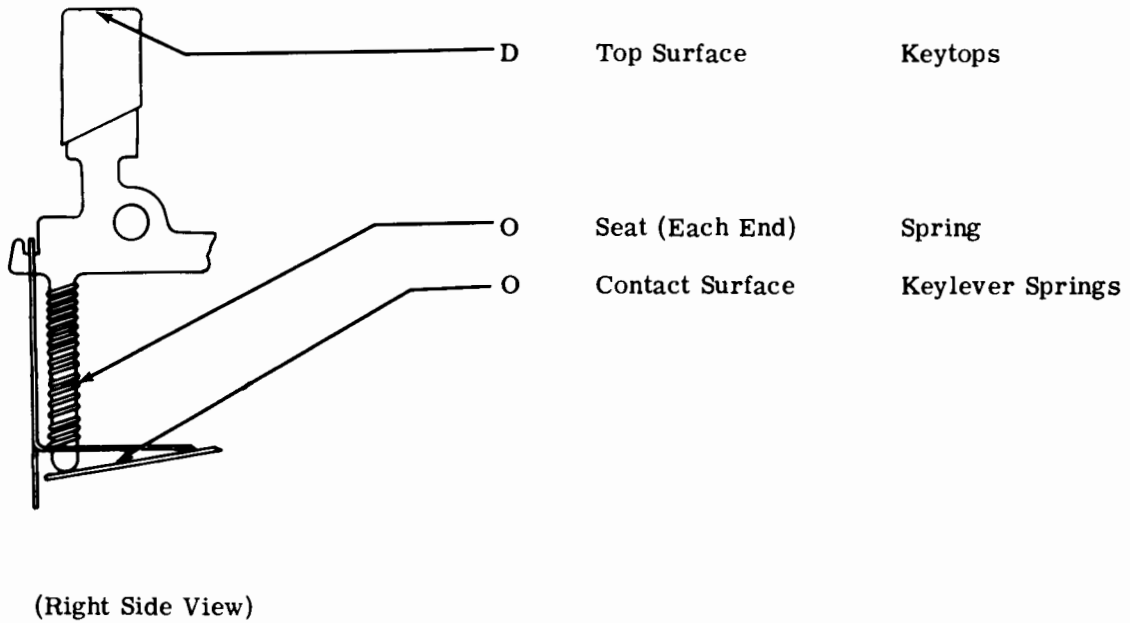

→ 2.15 Locking Mechanism (Units So Equipped)

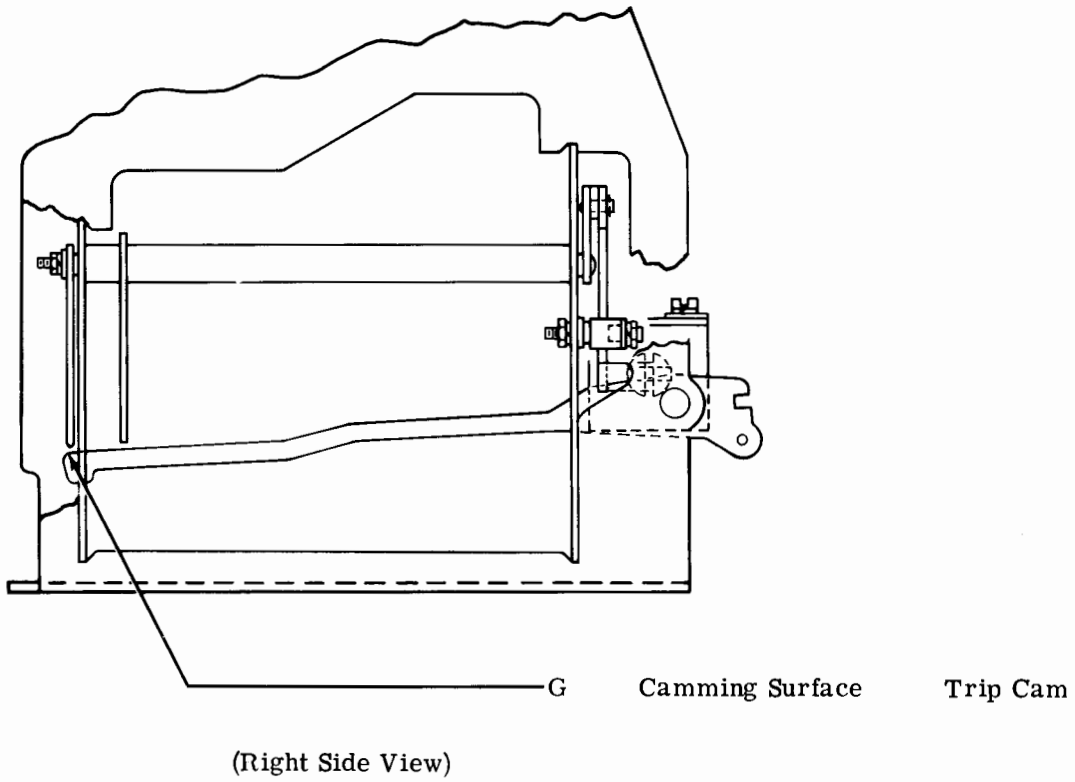
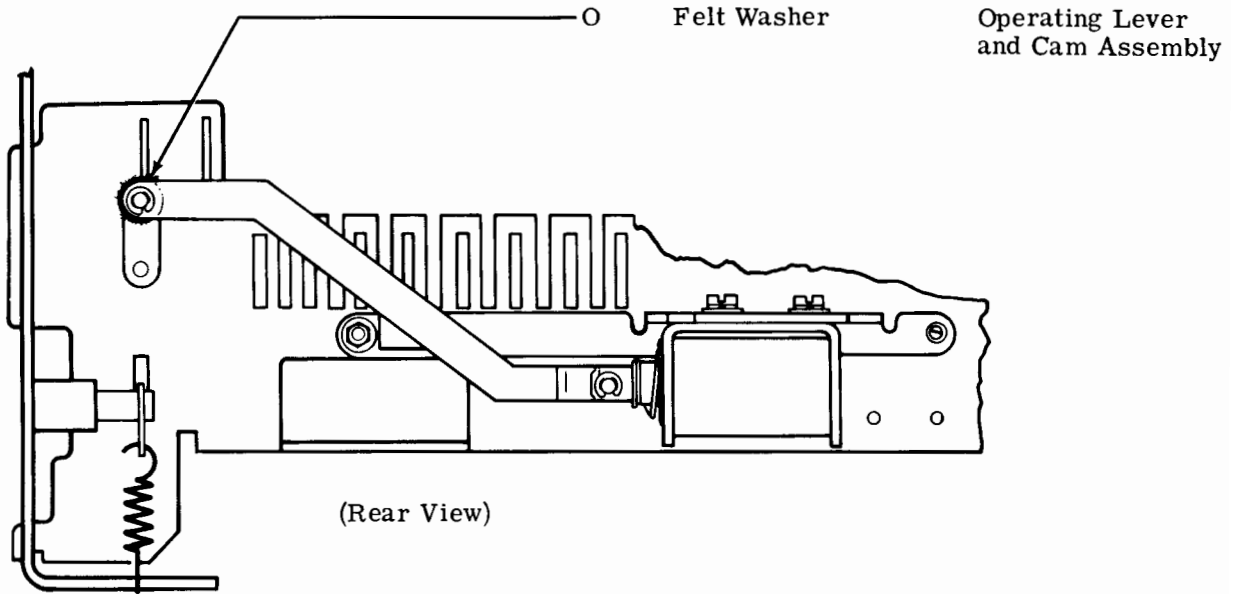

33 KEYBOARD

DISASSEMBLY AND REASSEMBLY

CONTENTS	PAGE
1. GENERAL.	1
2. DISASSEMBLY AND REASSEMBLY . .	1
KEYLEVER COVER	1
KEYLEVER.	2
SPACEBAR MECHANISM.	3
CODEBAR.	4
KEYBOARD CONTACT MECHANISM	4
AUXILIARY CONTACT MECHANISM	4
T-LEVER SHAFT.	4
3. DISASSEMBLY AND REASSEMBLY OF LOCKING MECHANISM IN KEYBOARDS SO EQUIPPED.	4 ←
1. GENERAL	
1.01 This section provides disassembly and reassembly for the 33 keyboard. It is reissued to make a few minor corrections. Mar- ginal arrows are used to indicate the changes.	←
1.02 References to left, right, front, rear, etc, consider the keyboard to be viewed from a position where the spacebar faces up and the contact mechanism is located to the viewer's right.	
1.03 Disassembly, as outlined in this section, covers the procedure for removing the principle subassemblies which make up the unit. If further disassembly is required, refer to the appropriate illustrated parts section which shows detailed arrangements of parts. Where it will	

help in determining their location, the numbers of the parts are given in the instructions.

CAUTION: BEFORE BEGINNING DISASSEMBLY, REMOVE CONNECTORS FROM EXTERNAL RECEPTACLES (POWER SOURCE, DATA SET, ETC).

1.04 When self-tapping screws are used to mount mechanisms onto castings, do not remove the self-tapping screws. Merely loosen them enough to remove the mechanisms unless specifically instructed otherwise.

1.05 Retaining rings are made of spring steel and have a tendency to release suddenly. To avoid loss of these rings when removing them, proceed as follows:

- (a) Hold retaining ring to prevent its rotating.
- (b) Place blade of screwdriver in one of ring's slots and rotate screwdriver to increase diameter.
- (c) Ring will come off easily in fingers without flying.

1.06 All tools used to remove the mechanisms referred to in this section can be found in the 570-005-800TC standard tool section.

1.07 All damaged, worn, or distorted parts should be replaced if encountered in the disassembly and reassembly procedures.

2. DISASSEMBLY AND REASSEMBLY

Note: For information concerning the proper procedure to remove the keyboard assemblies from the set, refer to appropriate disassembly and reassembly set section.

KEYBOARD COVER

2.01 To remove the keyboard cover (Figure 2), proceed as follows.

→ (a) Remove TP119652 retaining ring from the left side of the keyboard cover, and rotate the left side bracket and contact guard away from the unit.

(b) Hold the right side bracket firmly in place against the two TP180331 compression springs of keyboard contact mechanism, and remove the TP119652 retaining ring from the right side of the keyboard cover.

(c) Continue to hold the right side bracket firmly in place, and disengage the keyboard cover from the right side bracket by moving it up and to the left. Lift the keyboard cover off the keys.

Note: With the keyboard cover removed, the right side bracket may be pushed un-

expectedly from its assembled position, due to the spring load of two compression springs. If this happens, certain parts may prematurely fall off. To prevent this, always keep the right side bracket firmly against the two compression springs of the keyboard contact mechanism, i e, either hold the right side bracket in place by hand or place it firmly against a fixed vertical surface.

(d) To replace the keyboard cover, reverse the procedure used to remove it.

KEYLEVER

2.02 To remove any keylever (Figure 1), proceed as follows.

(a) Depress the front end of the TP182240 (early design) or TP185766 universal lever, or the TP186253 (late design) universal lever.

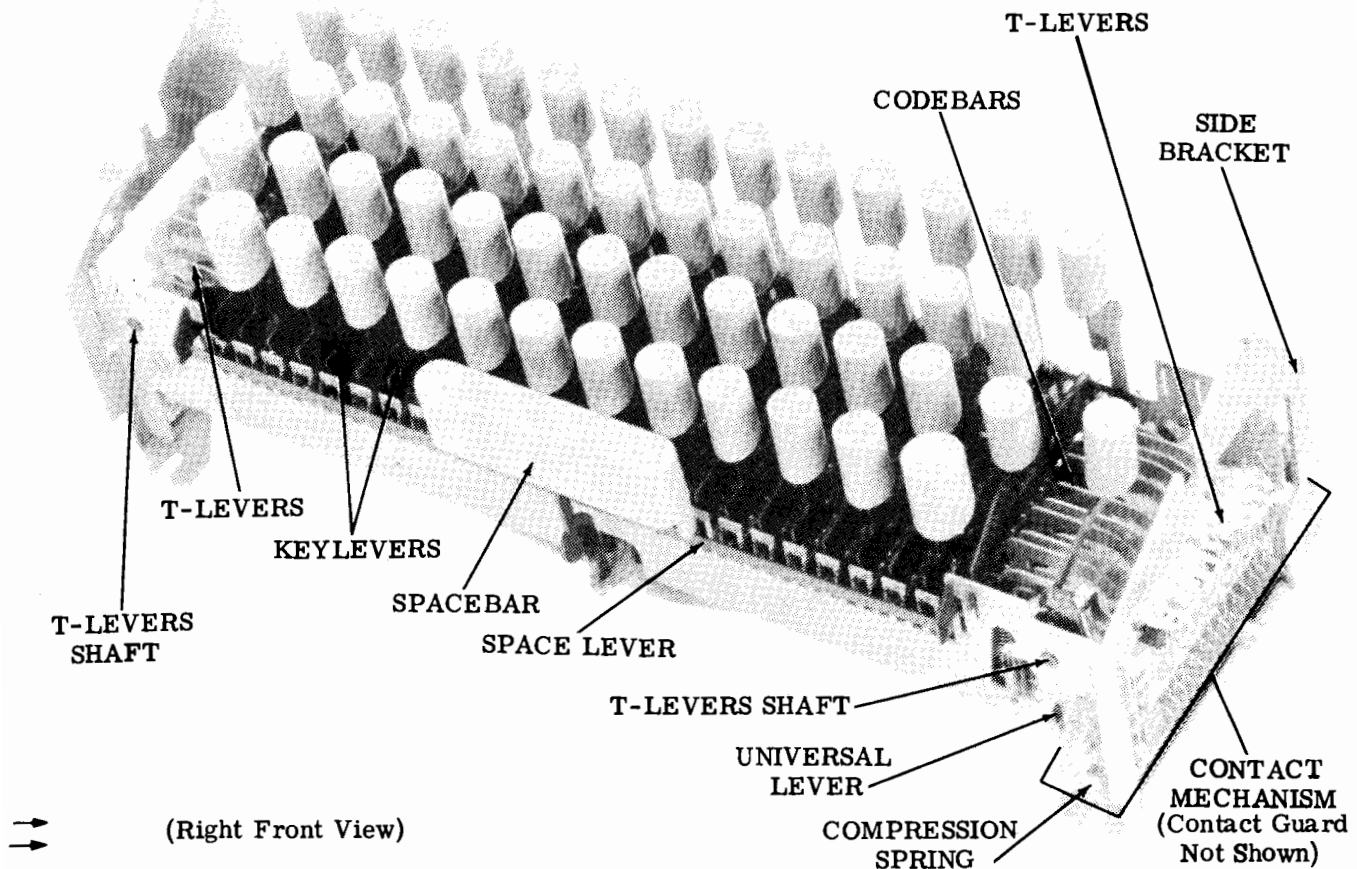

Figure 1 - Keyboard (Cover Removed)

- (b) Depress keylever and disengage it from front or rear guide slot.
- (c) Lift keylever out of keyboard frame.
- (d) To replace any keylever, reverse procedure used to remove it.

Note: Certain levers have compression springs on their lower stems. Make sure that the springs are properly replaced during reassembly.

SPACEBAR MECHANISM

2.03 To remove spacebar mechanism (Figure 1), proceed as follows.

- (a) Remove the TP180057 spacebar with the attached TP180054 keylever.
- (b) Bow the TP180056 space lever and disengage it from the two TP180055 space keylevers.

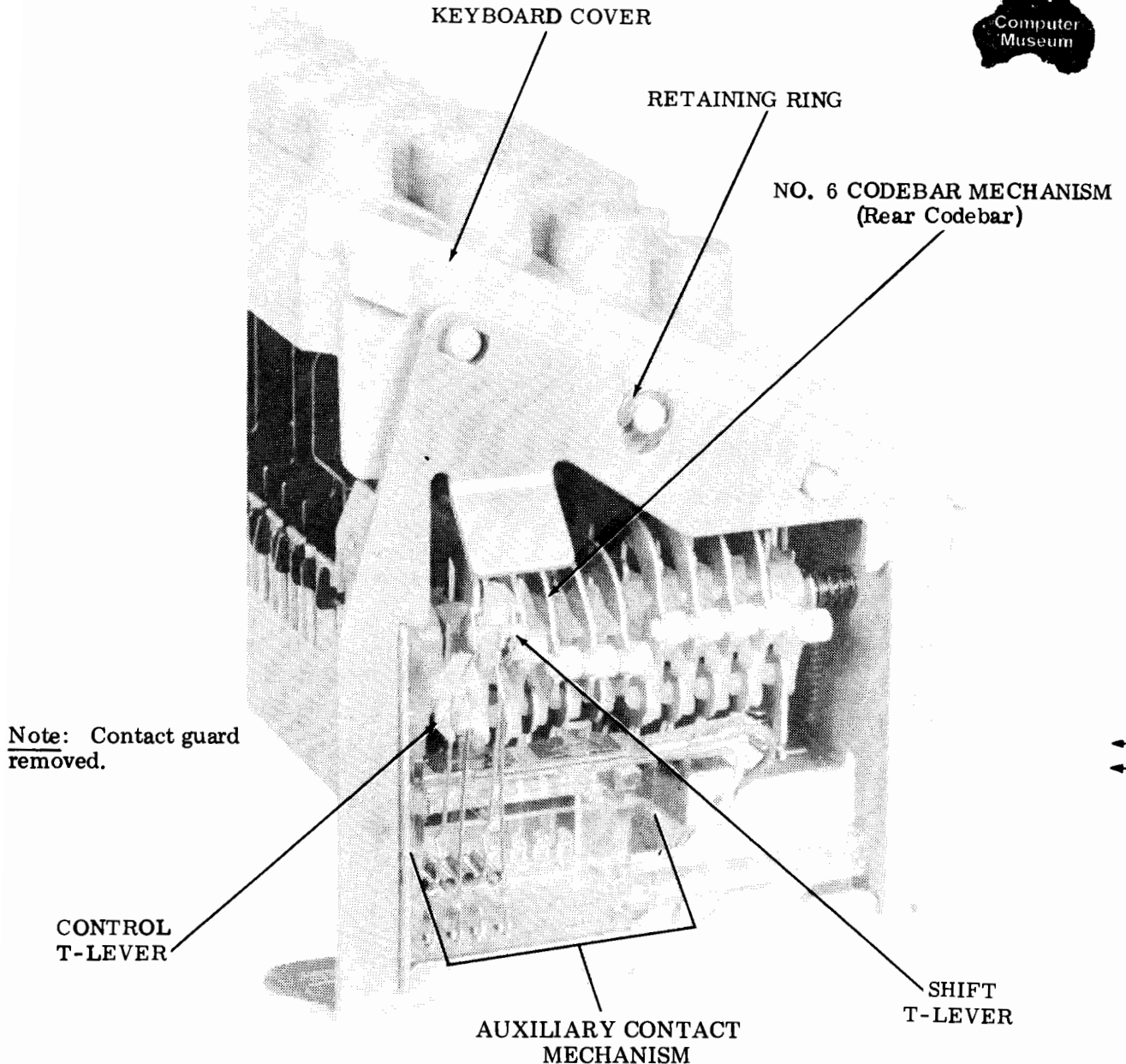

Figure 2 - Auxiliary Contact Mechanism

- (c) Disengage space keylevers from guide slots and remove them from frame.

Note: Careful attention should be given to the position of compression springs on keylever's lower stems so that they can be properly replaced during reassembly.

- (d) To replace spacebar, reverse procedure used to remove it.

CODEBAR

- 2.04 To remove any codebar (Figure 1), proceed as follows.

- (a) Remove all keylevers from typing unit.
- (b) Disengage codebars from left and right T-levers and remove them from keyboard frame.
- (c) To replace codebars, reverse procedure used to remove them.

KEYBOARD CONTACT MECHANISM

- 2.05 To remove keyboard contact mechanism (Figure 1), proceed as follows.

- (a) Disengage the TP185798 (early design) or TP186437 nonrepeat lever spring and the TP82442 (early design) or TP186435 universal lever spring.
- (b) Remove the right side bracket by snapping it off the frame.
- (c) Remove the contact mechanism.

Note: Careful attention should be given to the position of the TP180031 compression springs so that they may be properly replaced during reassembly.

- (d) To replace the keyboard contact mechanism, reverse the procedure used to remove it.

Note: Be sure that the TP180046 contact reset bail operating arm is located beneath the TP182240, TP185766 or TP186253 universal lever after reassembly.

AUXILIARY CONTACT MECHANISM

- 2.06 To remove auxiliary contact mechanism (Figure 2), proceed as follows.

Note: These instructions apply only to parity keyboards.

- (a) Remove left side bracket by snapping it off frame.
- (b) Disengage the TP42661 (early design) or the TP186339 (late design) shift codebar link spring.
- (c) Spread keyboard frame and remove the auxiliary contact.
- (d) To replace the auxiliary contact mechanism, reverse the procedure used to remove it.

T-LEVER SHAFTS

- 2.07 To remove the T-lever shafts (Figure 1), proceed as follows.

- (a) Disengage the TP84575 universal link spring.
- (b) Remove corresponding side bracket; spread the frame and lift out.

Note: If it is desired to remove T-levers, remove the TP119653 retaining rings and slide levers off their shafts.

- (c) To replace the T-lever shafts, reverse the procedure used to remove it.

3. DISASSEMBLY AND REASSEMBLY OF LOCKING MECHANISM IN KEYBOARDS SO EQUIPPED (Figure 3)

- 3.01 Remove TP119648 retaining ring. Remove TP186834 lever from post. Remove TP86079 felt washer.
- 3.02 Remove the solenoid plunger with the TP186834 lever attached to it.
 - (a) Remove TP119648 retaining ring from the TP183852 pin.
 - (b) Remove the TP183852 pin.

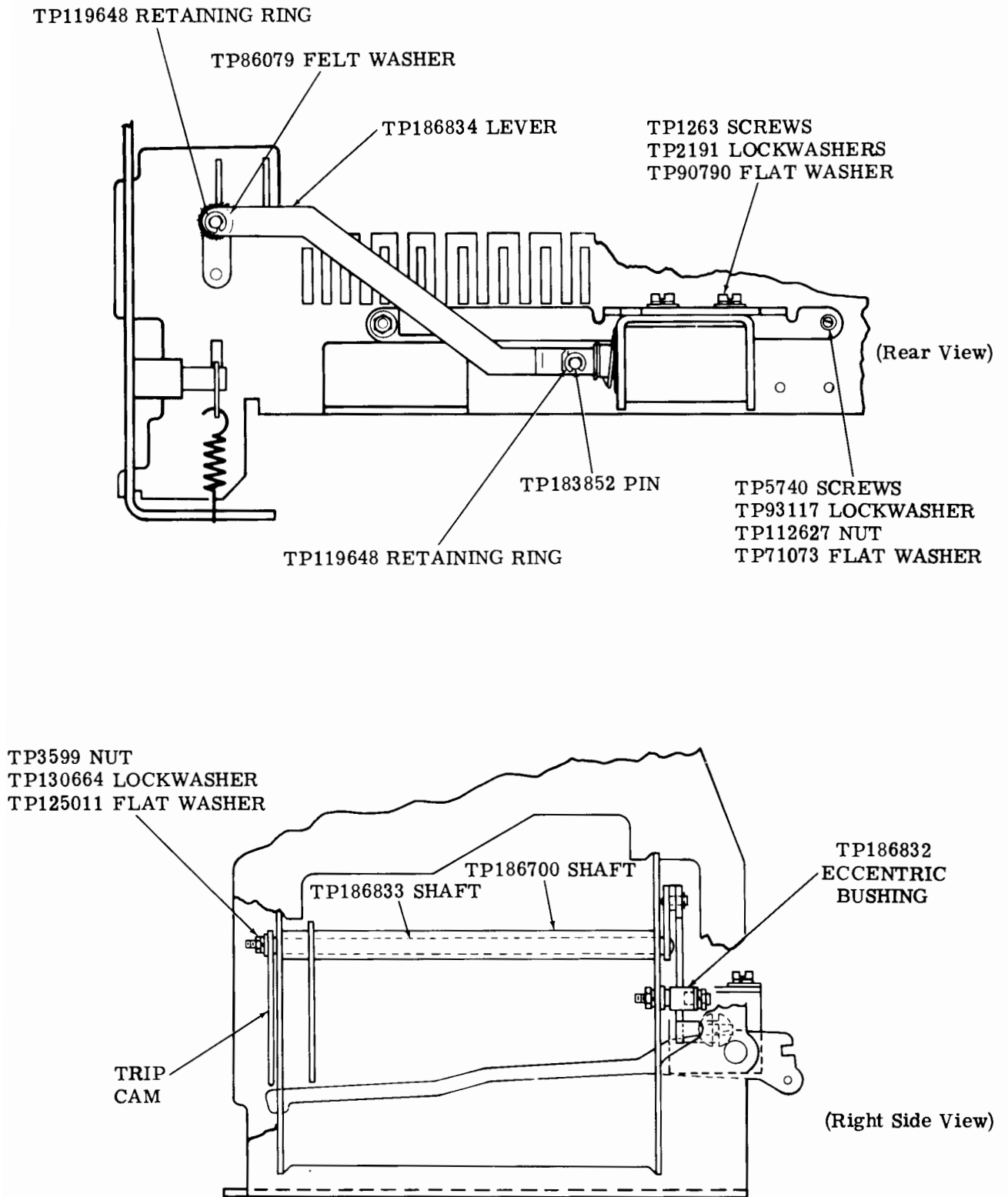

Figure 3 - Locking Mechanism on Keyboards So Equipped

SECTION 574-121-702TC

- (c) Remove the TP186834 lever from the slot in the solenoid plunger.
- 3.03 Remove TP186832 eccentric bushing from the stud on the TP186830 mounting bracket.
- 3.04 Disassemble trip cam by removing TP3599 nut, TP130664 lockwasher, and TP125011 flat washer.
- 3.05 Remove TP186833 shaft with lever from within the TP186700 shaft by pulling at the TP186833 from the rear of the keyboard.
- 3.06 Remove solenoid from its mounting bracket by removing two TP1263 screws, two TP2191 lockwashers, and two TP90790 flat washers.
- 3.07 Remove the solenoid mounting bracket with stud from the keyboard frame by removing the TP5740 screw, two TP93117 lockwashers, two TP112627 nuts, and TP71073 flat washer.
- 3.08 To reassemble the locking mechanism reverse the procedures used to remove it.

33 TYPING UNIT

GENERAL DESCRIPTION AND PRINCIPLES OF OPERATION

CONTENTS	PAGE	1. GENERAL
1. GENERAL	1	1.01 This section provides a general description and the principles of operation for the 33 typing unit. It is reissued to make a few minor corrections, to add a description of the automatic carriage return-line feed for sprocket feed typing units, and to add description of two print nonprint mechanisms. Marginal arrows indicate the changes and additions.
2. DESCRIPTION	1	
TECHNICAL DATA	1	
3. TELETYPEWRITER SIGNALING CODE	3	1.02 References to left, right, front, or rear consider the typing unit as viewed by the operator.
4. PRINCIPLES OF OPERATION	3	1.03 In the illustrations fixed pivots are solid black, and floating pivots — those mounted on parts that move, are crosshatched.
OUTLINE OF OPERATION	3	1.04 The 33 typing unit is an electromechanical receiving device which prints graphics on a paper copy according to a code, and performs nonprinting functions.
DETAILED OPERATION	8	
A. Motor	8	
B. Main Shaft	8	
C. Clutches	8	
D. Signal Reception	9	
E. Distributor Mechanism	9	
F. Selector Mechanism	11	
G. Range Finder	17	
H. Codebar Mechanism	17	
I. Function Mechanism	19	
J. Printing	21	
K. Printing Suppressed	27	
L. Ribbon Mechanism	29	
M. Spacing Mechanism	31	
N. Space Suppression Mechanism	32	
O. Carriage Return Mechanism	34	
P. Paper or Form Feeding	34	
Q. Sprocket Feed Typing Units	35	
R. Margin Bell and End of Line Bell	39	
S. Answer-Back Mechanism	40	
5. OPTIONAL FEATURES	47	2. DESCRIPTION
PRINT NONPRINT	47	TECHNICAL DATA
A. Magnet Operated	47	<u>Note:</u> This equipment is intended to be operated in a room environment within the temperature range of 40°F to 110°F. Serious damage to it could result if this range is exceeded. In this connection, particular caution should be exercised in using acoustical or other enclosures.
B. Solenoid Operated	48	2.01 Speed 100 words per minute
		2.02 Dimensions and Weight (Approximate)
		Width 13 inches
		Depth 14 inches
		Height 8 inches
		Weight 40 pounds

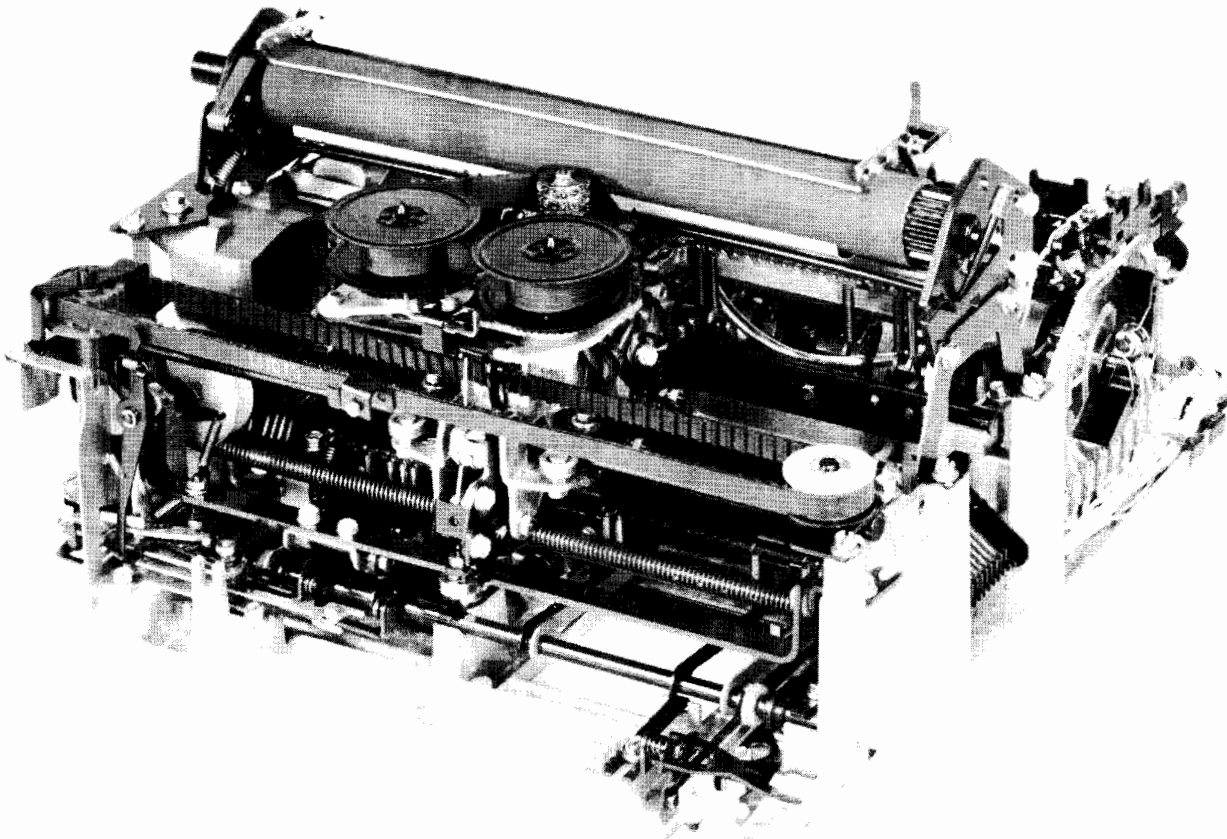

(Right Front View)

Figure 1 - 33 Typing Unit

2.03 Signal Code Characteristics

8-Level
11-Unit Transmission Pattern

2.04 Electrical

Power requirements 115 volts ac $\pm 10\%$
60 Hz ± 0.45 Hz, single phase
Signal line current . . 0.020 or 0.060 ampere
Nominal input to selector . . . 0.500 ampere
at 20 volts dc

Operating margins — all signal contacts
and distributor:

Long telegraph loops . . . 0.015 to 0.070
ampere at 48 to 240 volts dc
inductive
Short telegraph loops 0.58 to 0.72
ampere at 16 to 22 volts dc
resistive

2.05 Printing and Paper or Form Handling

Feed

Friction or Sprocket: Six lines per inch,
adjustable for single
or double line feed

Paper or Form

Friction Feed: 8-1/2 inches wide, max
5-inch diameter roll.

Sprocket Feed: 8-1/2 inches wide; 7-,
8-1/2-, 9-, 10-, 11-, and
12-inch form lengths
or multiples of 1/3 or
1/2 thereof.

Characters and Line

Friction Feed: 10 character per inch,
max 74 character line

Sprocket Feed: 10 characters per inch,
max 72 characters line

Legible Copies

Friction Feed: Original and one copy; when pressure sensitive paper is used, one original and two copies

Sprocket Feed: Original and two copies

2.06 Motor TP181870

Type Synchronous, capacitor start
 Input 115 v ac $\pm 10\%$, 60 Hz, single phase
 Input Current 2 amperes
 Output 33 millihorsepower
 Speed 3600 rpm
 Temperature Rating 130°C
 Power Factor 40%

2.07 Motor TP182241

Type Synchronous, capacitor start and run
 Input 115 v ac $\pm 10\%$, 60 Hz, single phase
 Input Current 1.6 ampere
 Output 33 millihorsepower
 Speed 3600 rpm
 Temperature Rating 130°C
 Power Factor 40%

2.08 Motor TP182267

Type Synchronous, capacitor start and run
 Input 115 v ac $\pm 10\%$, 50 Hz, single phase
 Input Current 1.7 ampere
 Output 35 millihorsepower
 Speed 3000 rpm
 Temperature Rating 130°C
 Power Factor 40%

3. TELETYPEWRITER SIGNALING CODE

3.01 The 33 Teletypewriter transmits and receives messages in the form of a start-stop signaling code. In this code each character or function is represented by current and no current time intervals. Current flowing in the signal line is referred to as marking; no current flowing in the signal line is referred to as spacing.

3.02 To represent a character or a function eleven pulses are used. The first pulse, which is always spacing, is the start pulse.

The next eight pulses are the intelligence pulses. The tenth and eleventh pulses, which are always marking, are the stop pulses. The start and stop pulses are used to synchronize sending and receiving equipment.

3.03 The code used by the 33 typing unit is known as ASCII (American National Standard Code for Information Interchange) and is illustrated in Figure 2. Since it has eight intelligence pulses and three synchronizing pulses it is an 8-level code with an 11-unit transmission pattern.

Start pulse	1 unit of time
Intelligence pulses	8 units of time
Stop pulses	2 units of time
	<u>11-unit code</u>

3.04 The ASCII utilizes only the first seven intelligence pulses, the eighth being used to provide an error detection feature called "even parity." When "even parity" is not provided, the eighth intelligence pulse is always transmitted as a marking pulse. With seven intelligence pulses available, ASCII can accommodate 2⁷ or 128 permutations. Of these 64 are assigned to printing characters. The rest are devoted to nonprinting characters, or are unassigned.

3.05 The character arrangement for ASCII is shown in Figure 2. The black circles represent marking pulses, the blank squares spacing pulses. The main block gives the arrangements of pulses 1 through 5. The four smaller blocks at the right give the arrangements of pulses 6 and 7 for the four rows of characters as indicated by the arrows. When "even parity" is provided, characters and functions which have white backgrounds in the character arrangement illustration have the eighth intelligence pulse spacing — dark backgrounds have the eighth intelligence pulse marking. For keyboard transmission, two SHIFT keys and a CTRL key are used as described in the keyboard section.

4. PRINCIPLES OF OPERATION

OUTLINE OF OPERATION (Figure 3)

Power Distribution

4.01 Operation of the motor switch supplies ac power to the motor. By means of intermediate drive parts the rotary motion of the

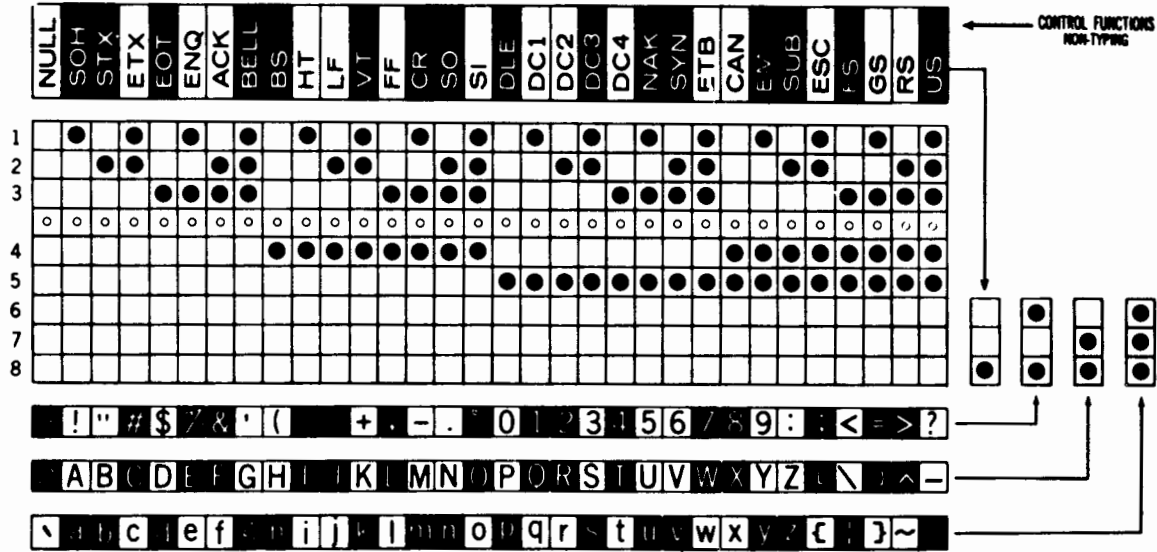

AMERICAN NATIONAL STANDARD CODE FOR INFORMATION INTERCHANGE (ASCII) X3.4-1968

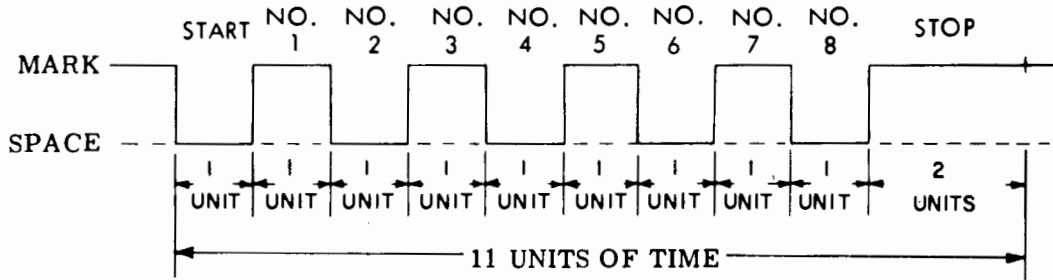

CURRENT WAVE FORM FOR LETTER "U" (WITH "EVEN PARITY")

Figure 2 - Teletypewriter Code (8-Level)

motor is transferred to a distributor shaft. The distributor shaft drives the main shaft and, by means of a clutch, provides motion for the distributor mechanism.

Transmission

4.02 The distributor receives a parallel output from the keyboard and converts it into a serial start-stop code combination. A selector magnet driver receives the distributor serial output and converts it into a form suitable to operate the selector mechanism. The selector mechanism in turn receives the signal and positions the codebar mechanism.

Function Mechanism

4.03 Controlled by the codebar mechanism, the function mechanism enables the typing unit to perform functions supplementary to printing. The standard functions are "space," "carriage return," "line feed," "blank," and "bell."

Spacing Mechanism

4.04 The spacing mechanism positions the carriage so that the characters are properly located horizontally on the paper. It spaces the carriage each time printing occurs and when

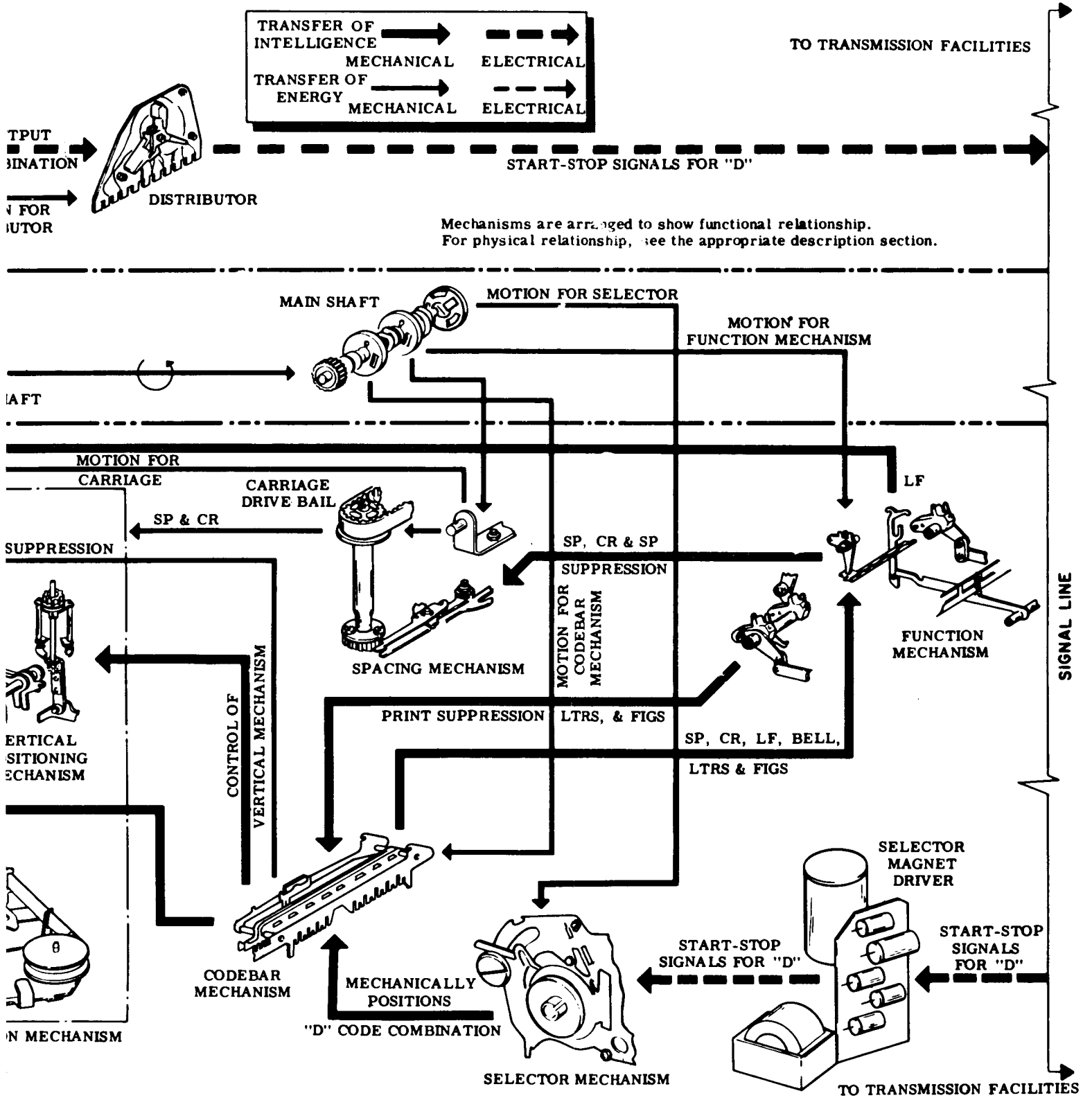
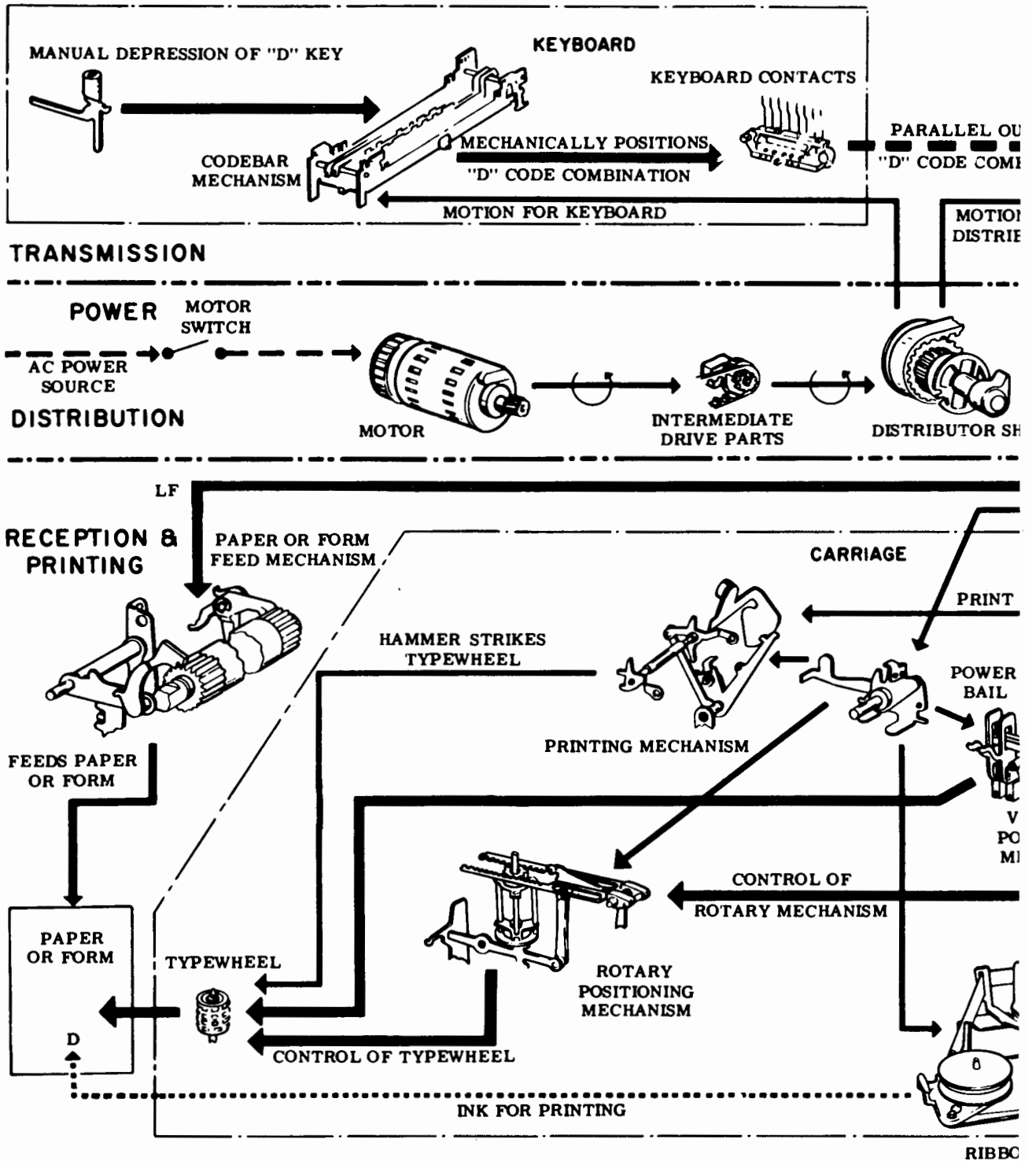

Figure 3 - Schematic Diagram - Typing Unit Operation



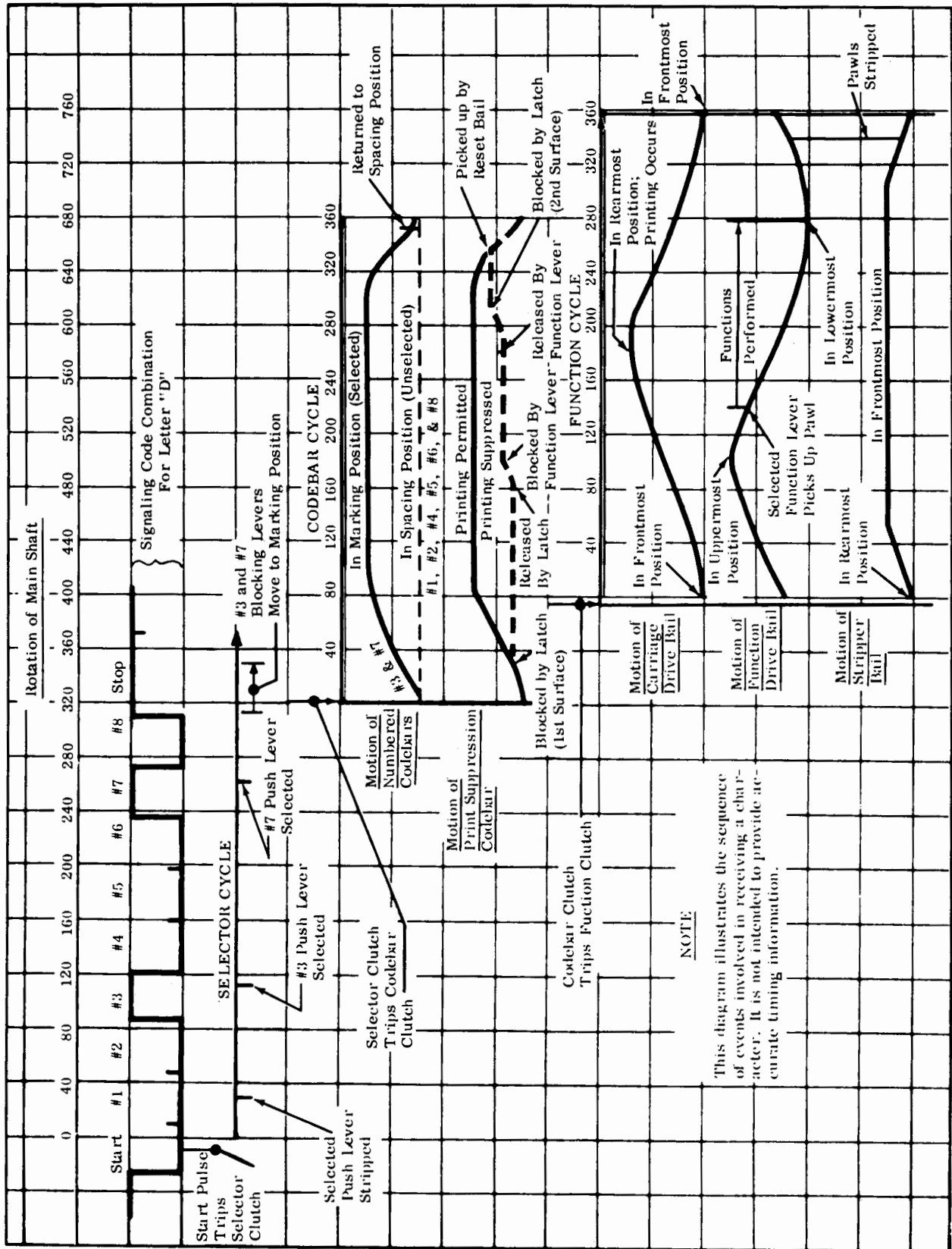

Figure 4 - Sequence Diagram — 33 Typing Unit Operation

the "space" code combination is received. The function mechanism suppresses spacing on the receipt of all functions except "space." At the receipt of "carriage return" code combination, the function mechanism causes the spacing mechanism to return the carriage to the left margin, so that a new printing line can be started.

Paper Feed Mechanism — Friction Feed Typing Units

4.05 The paper feed mechanism positions the paper vertically so that the characters are properly located in lines on the paper. At the receipt of the "line feed" code combination, the function mechanism causes the line feed mechanism to raise the paper to the next printing line.

Form-Feed Mechanism — Sprocket Feed Typing Units

4.06 The form-out mechanism positions the form vertically so that the characters are properly located in lines on the form. At the receipt of the "line feed" or "form out" code combination, the main shaft, through a line feed clutch, causes the platen to raise the form to either the next printing line or one form length, depending upon which function ("line feed" or "form out") is used.

DETAILED OPERATION

A. Motor

4.07 The motor used on the 33 typing unit has a run winding and a start winding connected in parallel. (See the appropriate schematic wiring diagram.) The start winding is in series with an electrolytic capacitor and the contacts of a current-sensitive start relay. The run winding is connected to a run capacitor. When the motor circuit is closed, the initial surge of current energizes the relay coil, closing the relay contacts. The magnetic flux produced by the operating and start windings starts the motor turning. As the rotor accelerates, the current, through the windings, capacitor, and relay decreases. When it drops to a predetermined level, the relay coil opens the contacts and removes the start coil from the circuit. Using the operating coil alone, the motor continues to accelerate until it reaches synchronous speed.

4.08 The rotary motion produced by the motor is transferred through a motor pinion, an intermediate gear pulley, and a motor belt to a distributor gear pulley. The latter drives a main shaft gear and also a distributor clutch, which provides motion for the keyboard and distributor mechanism (Figure 5).

B. Main Shaft

4.09 The main shaft illustrated in Figure 6 receives motion from the motor, and by means of clutches distributes it to drive all the mechanisms in the typing unit except the distributor mechanism. The distributor mechanism is driven by the motor directly as explained in 4.08. In friction feed typing units the main shaft drives three clutches: the selector clutch, the function clutch, and the codebar clutch. In sprocket feed typing units the main shaft drives an additional clutch — the form feed clutch.

C. Clutches

4.10 The clutches used on the 33 typing unit are all metal internal expansion clutches. A clutch is illustrated in Figure 7. This type of clutch functions like brakes. When the clutch is tripped (engaged) two shoes expand against a notched drum. The force of the expanded shoes against the clutch drum is enough to engage the drum. As the drum rotates, the whole clutch and any mechanism attached to it will rotate.

4.11 The clutch drum is attached to and rotates with a shaft. In the stop (or disengaged) position, a trip lever and a latch lever hold the shoe lever, two shoes, a cam disc, and a cam sleeve stationary. When the trip lever moves away from the shoe lever, the shoe lever, under spring tension, moves away from the stop lug on the cam disc. By means of two lugs, the shoe lever expands the shoes until they contact the notched surface of the drum. The drum causes the shoes to rotate. By means of a lug on the cam disc the shoes rotate the disc and the sleeve attached to it. The clutch is now engaged, and the cam sleeve rotates in unison with the shaft.

4.12 When the trip lever moves to its stop position, it is struck by the shoe lever. The cam disc continues to rotate until the latch lever seats in its notch, and the shoe lever and stop lug are pressed together by the trip lever and latch lever. A spring holds the shoes together, away from the drum. The clutch is now disengaged.

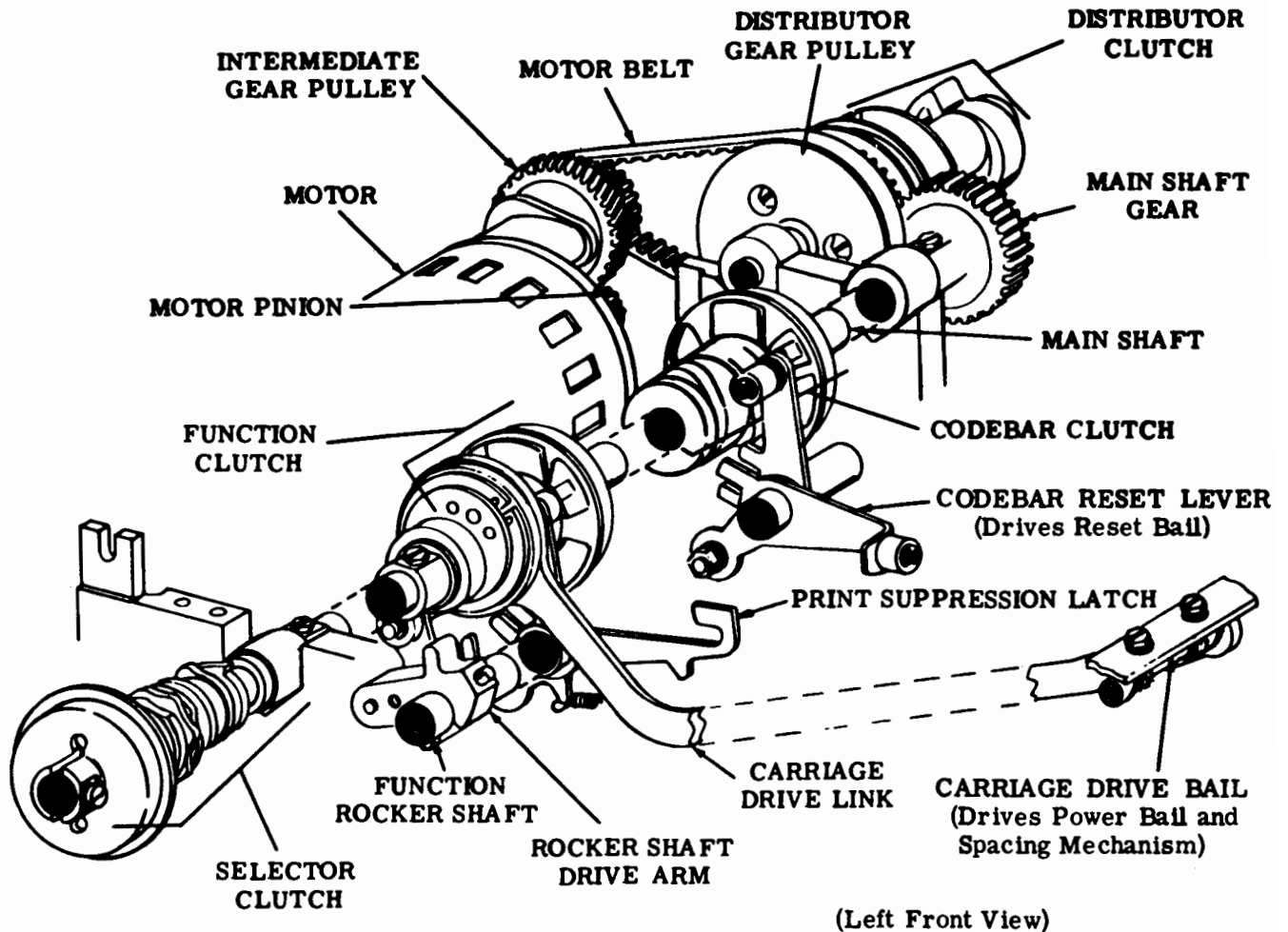

Figure 5 - Motor and Drive Mechanism

D. Signal Reception

4.13 The signal received by the typing unit may originate either remotely or locally. Locally the signal may originate either in the keyboard or the tape reader. In either case, the incoming signal is received as a parallel output to the distributor. The distributor changes the parallel signal into a serial start-stop output to the selector magnet driver for current rectification. The signal goes from the selector magnet driver to the selector. The following paragraphs will consider the signal as originating in the keyboard. Refer to Section 574-121-100TC for the description of keyboard operation.

E. Distributor Mechanism

4.14 The distributor mechanism is illustrated in Figures 8 and 9. When a keytop is depressed, the corresponding code combination is set up in the keyboard contacts. Simultaneously the universal lever moves up. An H-plate connects the universal lever of the keyboard to the distributor clutch trip linkage in the typing unit. As the universal lever moves up, the H-plate pivots the distributor trip linkage. The distributor trip linkage is connected to the clutch trip lever. As the linkage moves rearward the trip lever is moved away from the shoe lever and the distributor clutch engages.

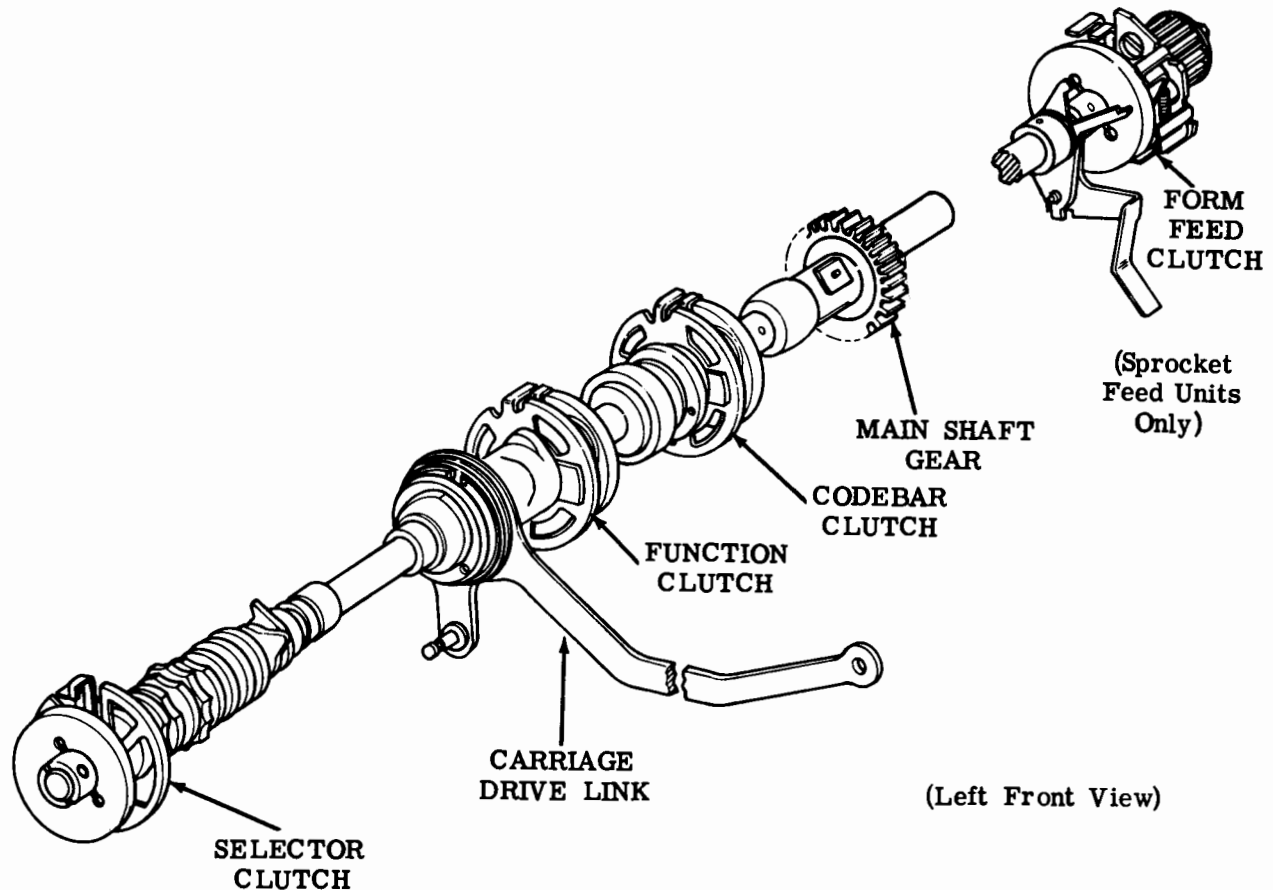

Figure 6 - Main Shaft

4.15 The clutch disc is attached to the distributor shaft. A brush holder mounted at the end of the distributor shaft rotates two carbon brushes over the segments of the distributor disc. A spring fastened to the brush holder serves two purposes: it holds the carbon brushes firmly against the segments, and serves to close the current loop between the outer and inner rings of the distributor disc.

4.16 The distributor disc has two rings. The inner ring is solid. The outer ring is broken into ten segments corresponding to the start, stop, and the eight intelligence pulses.

(a) In the stop position, the outer brush rests on the stop segment, and the current flows in the signal circuit which is closed. (The signal path is from one side of the line through the start segment, the inner ring, the brushes, the stop segment, the common terminal, and the break contact to the other side of the line.) Thus a marking condition exists. Assume that the D key is depressed. The (--3---7-) code combination is set up in the keyboard contacts.

(b) The distributor clutch is tripped, and the brush holder begins its revolution. While the brush is on the start segment, the

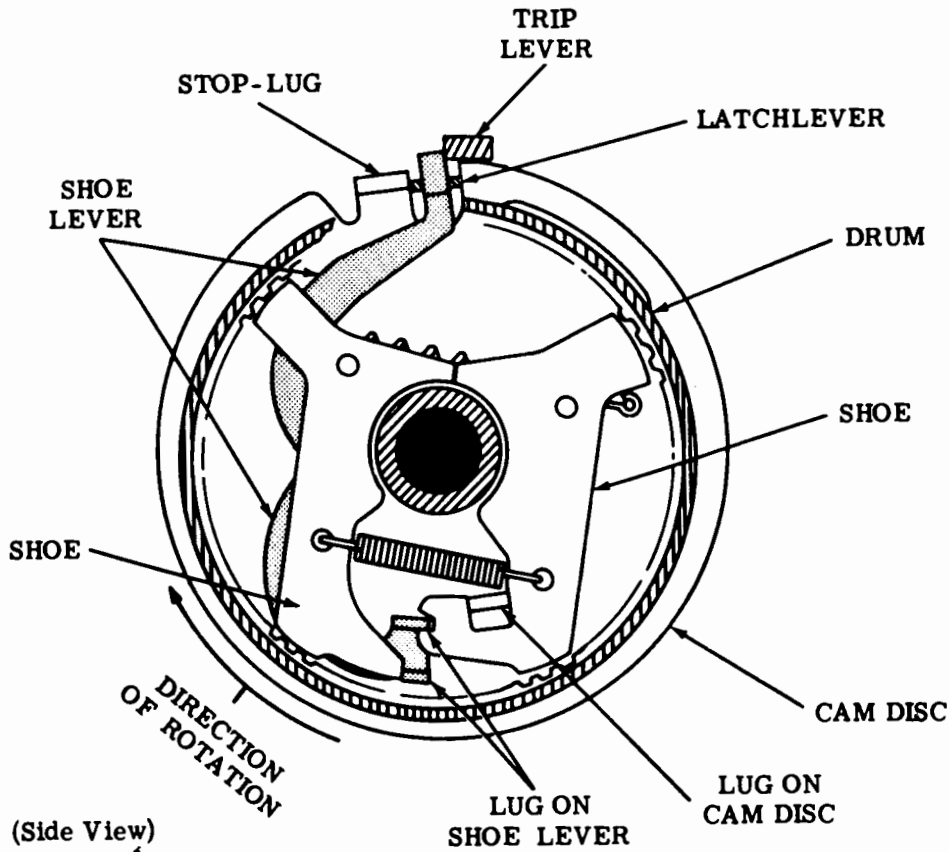

Figure 7 - Internal Expansion Clutch

circuit is open, no current flows, and a spacing element is transmitted. While it is on the no. 1 segment, the circuit is again open. Likewise the circuit is open for the no. 2 pulse. On the no. 3 segment the circuit is closed, current flows and a marking element is transmitted. For the nos. 4, 5, and 6 segments the circuit is open, transmitting spacing elements. The circuit closes for the no. 7 element and opens for the no. 8. When the brush reaches the stop segment, the distributor clutch is disengaged, and the line again becomes marking.

F. Selector Mechanism

4.17 The selector mechanism illustrated in Figures 10 and 13 receives the code combinations from the selector magnet driver and converts them to mechanical arrangements that control the codebar mechanism.

4.18 A magnet coil is wired by two leads to the output of the selector magnet driver. In the stop condition the output of the selector magnet driver is marking. This keeps the coil energized and the armature attracted to the magnet core. In this attracted position the armature blocks the start lever.

4.19 When a code combination is received the start pulse (spacing) de-energizes the coil, and the armature drops away from the magnet. No longer blocked, the spring biased start lever overtravels the armature, causing two things to happen:

- (a) The start cam follower associated with the start lever falls into the indent of the start cam.
- (b) As the start cam follower falls into the indent, the trip lever associated with it moves away from the clutch shoe lever, allowing the selector clutch to engage.

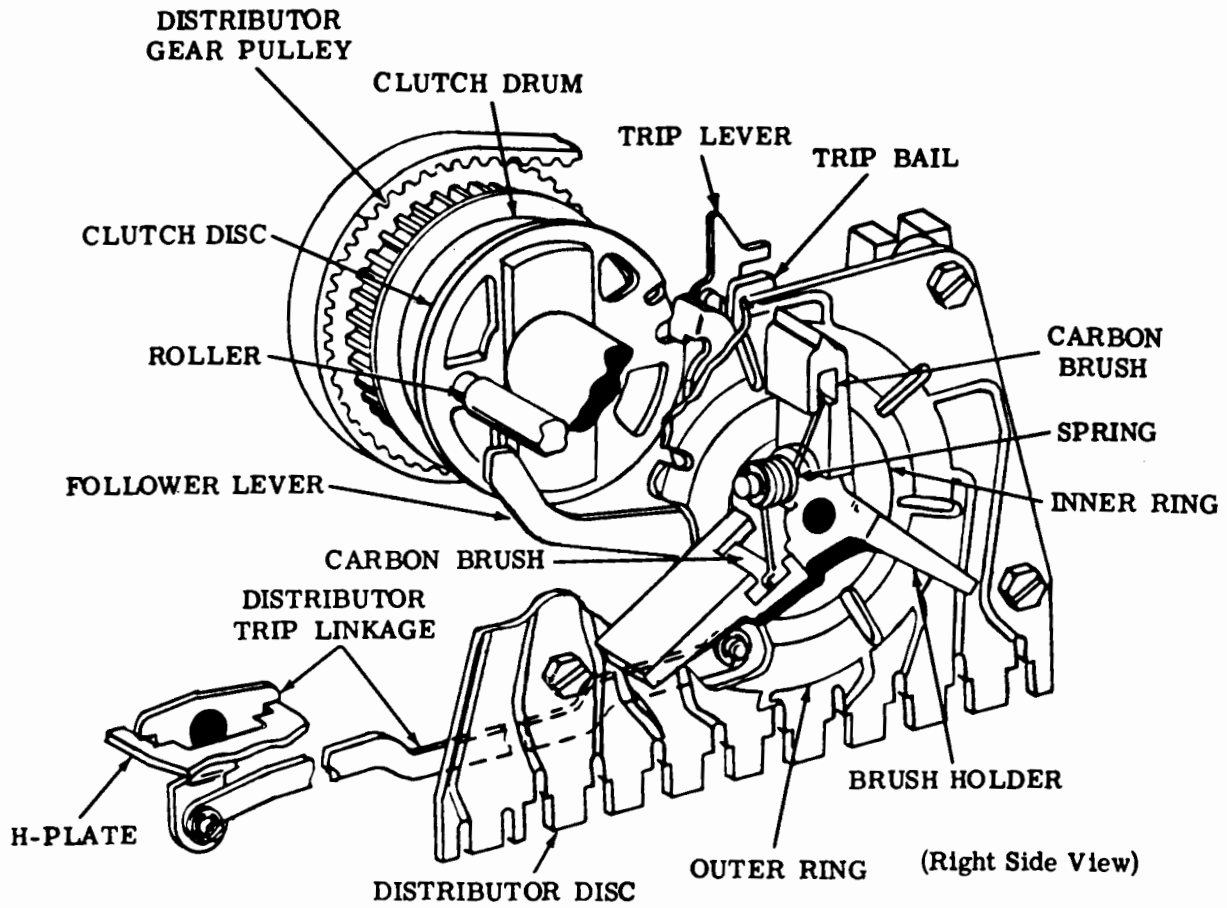

Figure 8 - Distributor Mechanism

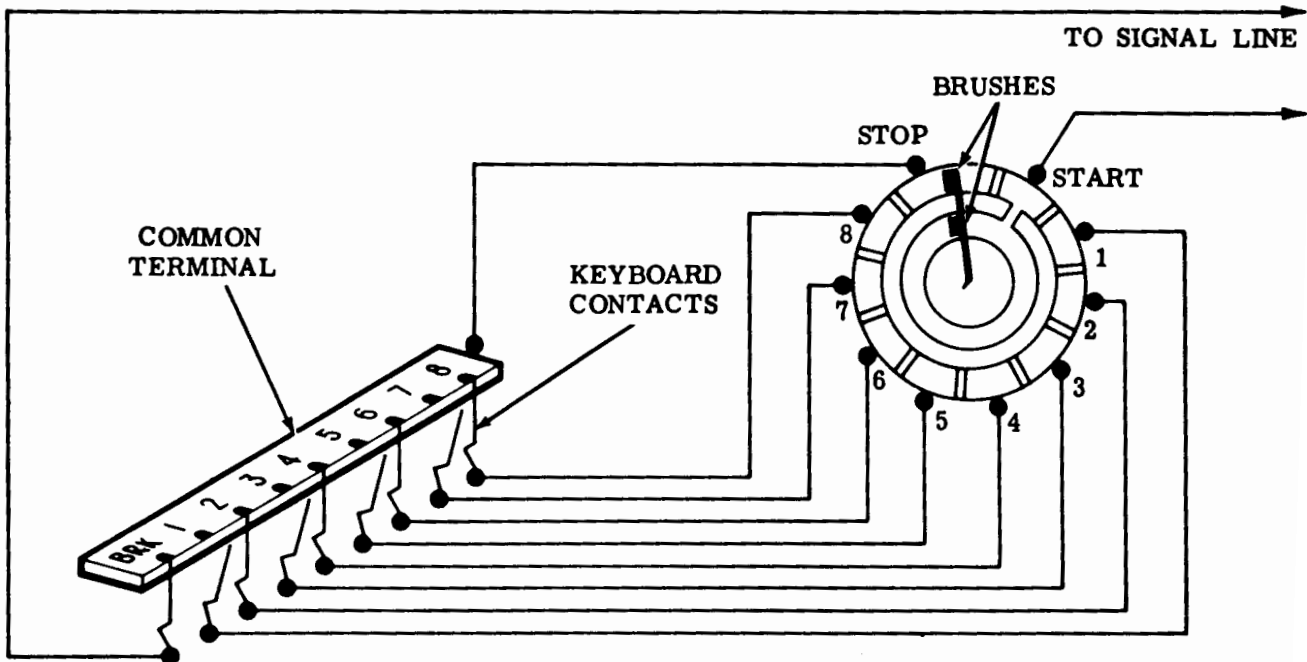

Figure 9 - Signal Wiring for 33 Typing Unit Distributor

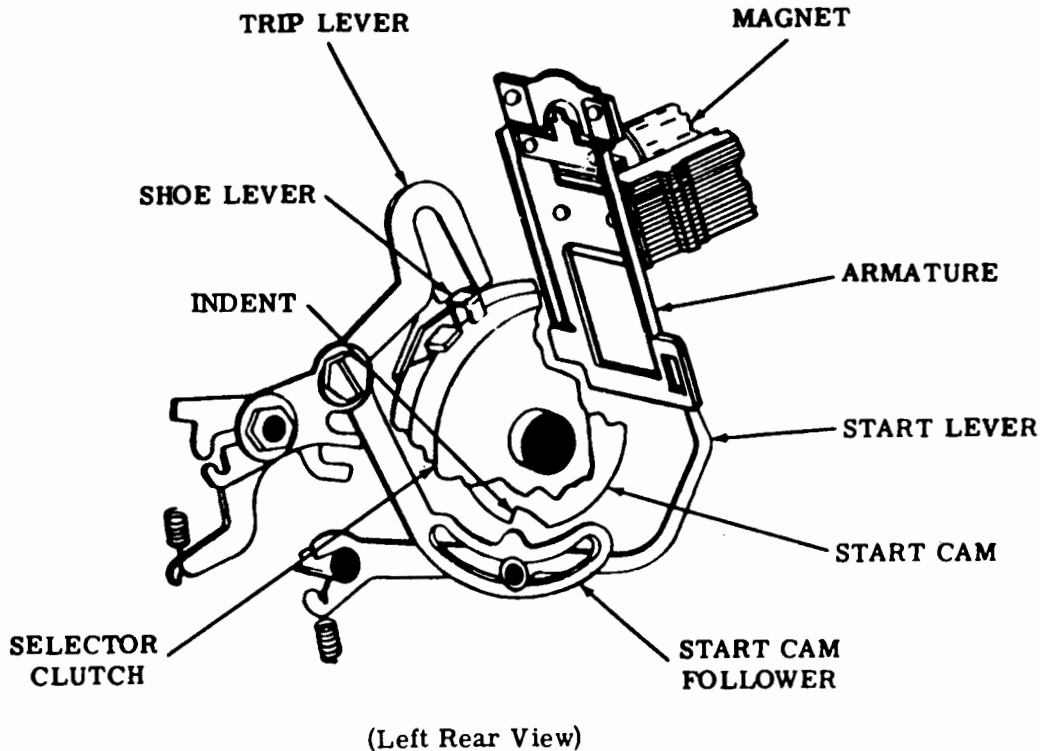

Figure 10 - Selector Trip Mechanism

4.20 Once engaged the selector clutch makes one complete revolution. The start cam follower remains in the indent of the start cam just enough to trip the clutch. It then comes out of the indent and rides the cam. This keeps the start lever away from the armature which will now be attracted if the incoming pulses are marking and unattracted if the pulses are spacing.

4.21 As the selector clutch rotates, the spacing locklever, the push lever reset bail, the codebar clutch trip follower arm, and eight selector levers ride individual cams under spring tension.

4.22 Early in the codebar cycle the high part of the push lever reset cam pivots the push lever reset bail. In its motion the bail

resets all the spring biased push levers selected in the previous cycle. Once reset the push levers can be positioned either marking or spacing as the intelligence pulses are received.

4.23 The selector cam sleeve illustrated in Figure 11 has twelve cam surfaces. The cam surfaces are positioned in a staggered fashion so that a sampling sequence can take place. As mentioned in 4.19 and 4.20, the start cam performs its function, and soon after the push lever reset cam is operated. Following these the spacing locklever cam and the eight intelligence cams operate in sequence.

Note: The sampling sequence for the intelligence cams is as follows: no. 1, 2, 3, 4, 5, 6, 7, and 8. However, the physical arrangement of the cams is: 1, 2, 3, 4, 5, 7, 6, and 8 as viewed from left to right.

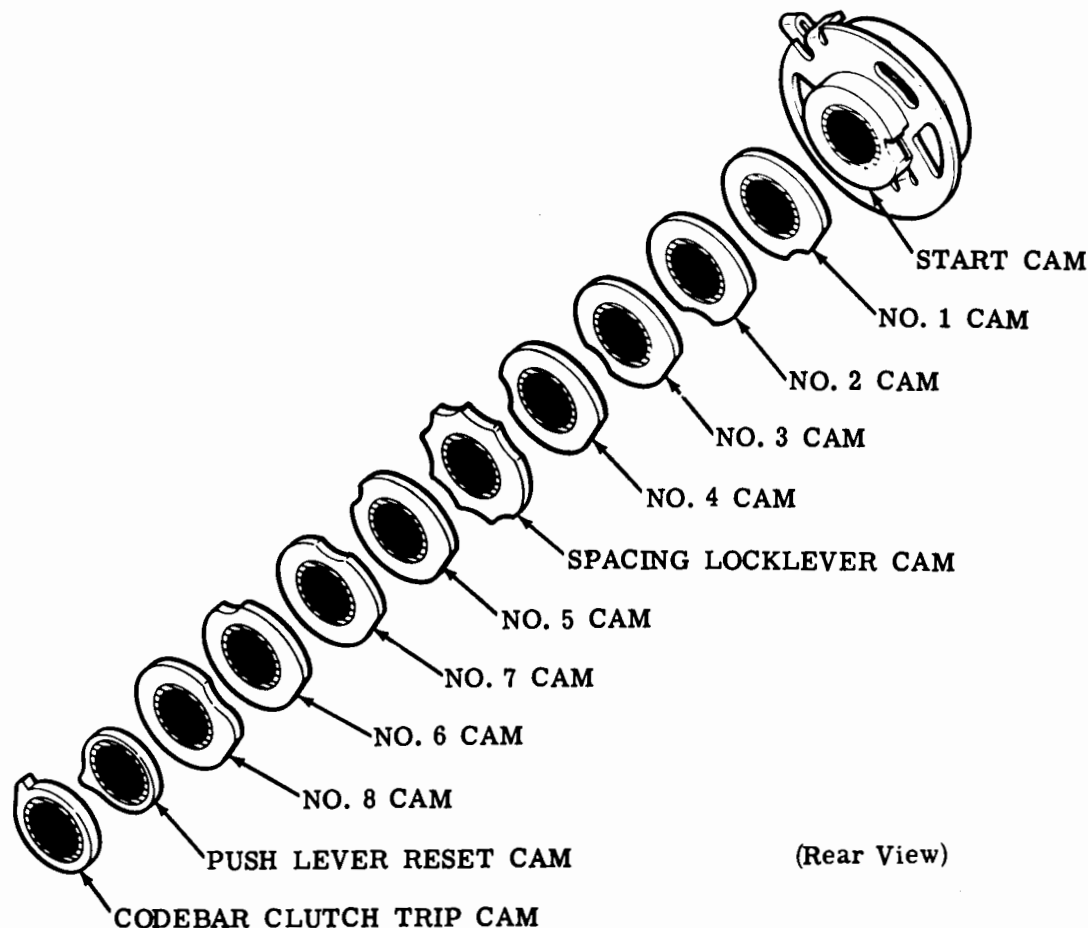

Figure 11 - Selector Cam Sleeve

4.24 If the intelligence pulse is spacing it de-energizes the magnet coil and the armature is in the unattracted position. The spacing lock lever moves up, holding the armature in this position during the sampling interval. The selector lever is prevented from moving up into the indent of its cam by the armature, and the push lever remains in its unselected (spacing) position in front of the selector lever (Figure 13).

4.25 If the intelligence pulse is marking the armature is attracted, moving out of the way of the selector lever, blocking the spacing locklever. The selector lever moves up into the indent of its cam, locking the armature in its marking position during the sampling interval. This permits the spring biased push lever to move rearward under the selector lever.

4.26 As the code combination is received, each intelligence pulse is sampled in turn, and the corresponding selector levers and push levers are positioned accordingly. The contours of the selector cams are such that near the end of the cycle they drive the selector levers and selected push levers towards the front of the typing unit to their marking position. In this position their slotted portions are up. The blocking levers associated with the unselected push levers remain in the spacing position in which their slotted portion is down (Figure 13).

4.27 Near the end of the cycle, the trip follower arm is moved rearward by its cam and trips the codebar clutch.

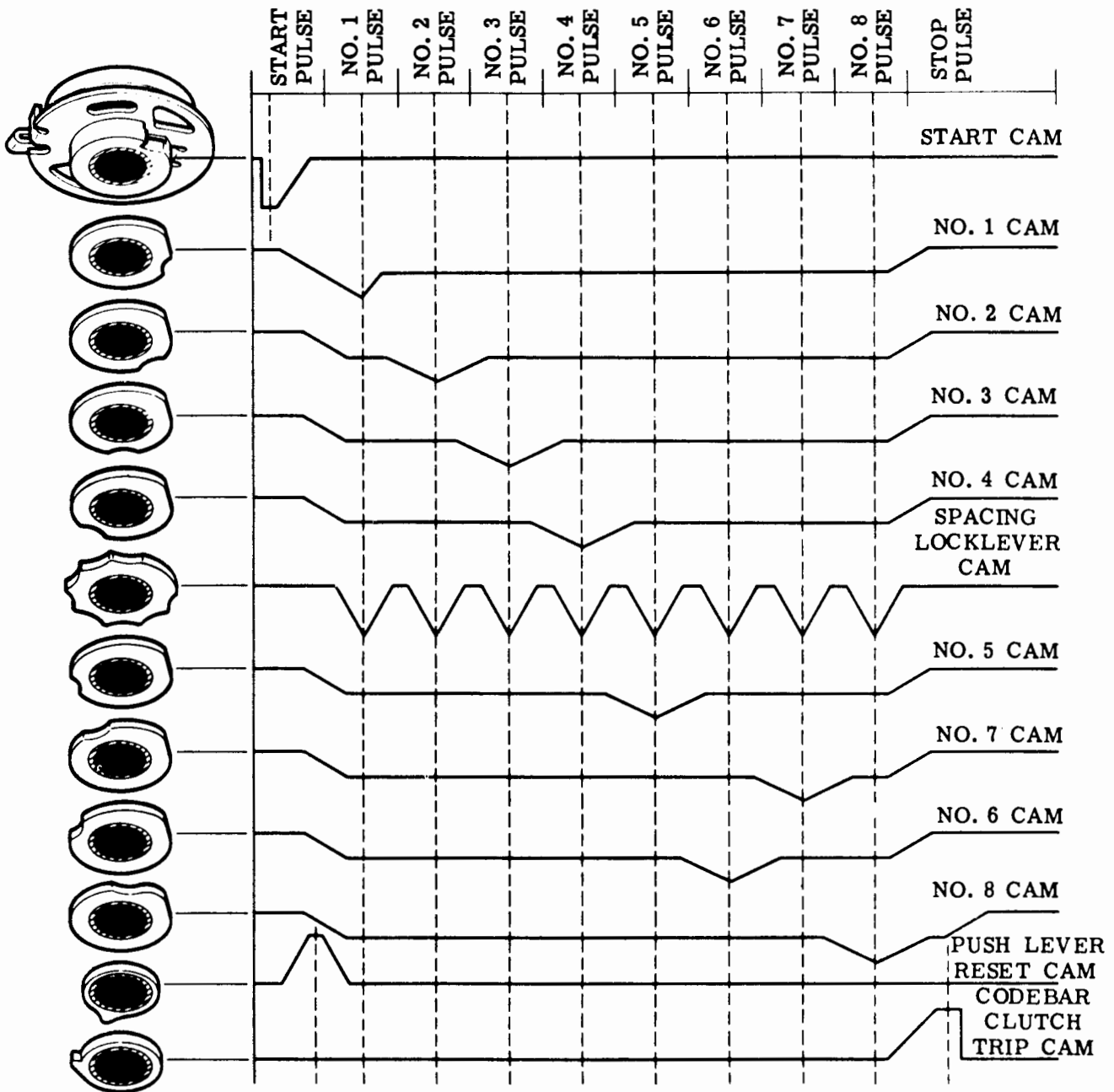

Note: This illustration is intended to show relationships of operations. It is not meant to be a timing chart.

Figure 12 - Sequence and Relationships of Selector Cams Operations

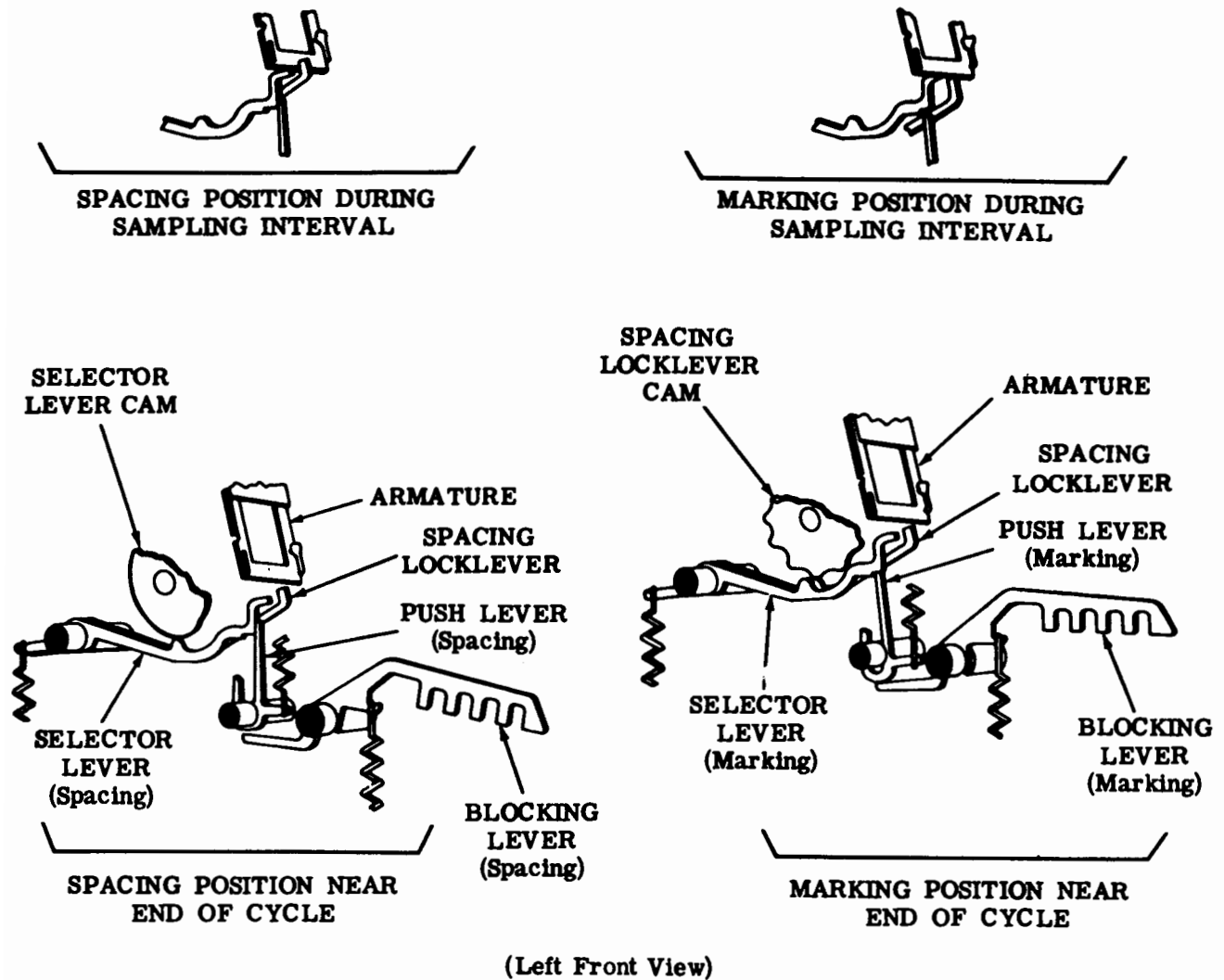

Figure 13 - Selector Mechanism

4.28 When the stop pulse (marking) is received at the end of the code combination, the armature moves to its marking position above the start lever, where it prevents the start cam follower from falling into the indent of its cam. In this position the follower holds the trip lever down so that, when the selector clutch completes its cycle, its shoe

lever strikes the trip lever, and the clutch is disengaged.

4.29 As an example, assume that the letter D (--3---7-) code combination is received by the typing unit. The start pulse (spacing) trips the selector clutch, which begins its cycle. The stripper bail strips all previ-

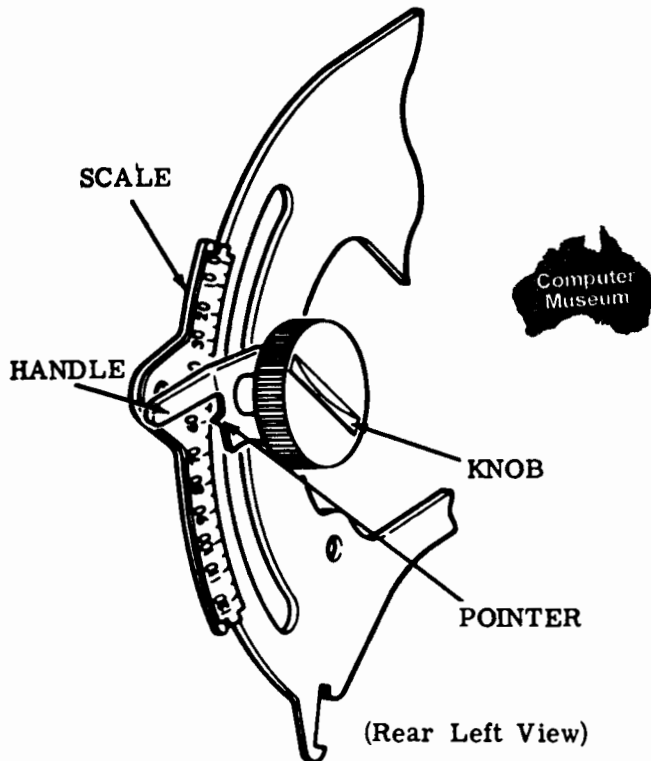

Figure 14 - Range Finder

ously selected push levers from the selector levers. The intelligence pulses are sampled in order, and the no. 3 and no. 7 push levers are selected. Near the end of the cycle the selector clutch cams the no. 3 and no. 7 push levers down, and they pivot the no. 3 and no. 7 blocking levers up to their marking position. The trip cam causes the trip follower arm to trip the codebar clutch. The stop pulse (marking) disengages the selector clutch, and the selector returns to its stop position.

G. Range Finder

4.30 For optimum operation of the typing unit, the selector must sample the code elements at the most favorable time. The range finder illustrated in Figure 14 provides a means of determining this time by establishing a range of operating margins.

4.31 When the range finder knob is loosened, a pointer may be moved along a range scale by a handle. This changes the angular position of the trip levers and latchlevers with respect to the main shaft, and thus changes the position where the selector clutch begins and

ends its cycle. The effect of this operation is to change the time in the cycle when the selector samples each code pulse.

4.32 Rotating the pointer counterclockwise from 60, the center of the scale, causes the selector to sample the trailing portion of the pulse. Rotating the pointer clockwise causes the selector to sample the leading edge. To establish the margins of the operating range, the pointer is moved first in one direction, then in the other, until errors in printing occur. The pointer is then set at the center of the range and the knob tightened.

H. Codebar Mechanism

4.33 As mentioned in 4.27, near the end of the selector cycle (towards the end of the eighth pulse) the codebar clutch trip cam pivots the codebar clutch trip follower arm. The arm, through a trip shaft, pivots the trip lever out of the way of the shoe lever. The codebar clutch engages and makes one revolution.

4.34 As the codebar clutch rotates, the codebar reset lever follows its camming surface under the pressure of the codebar reset bail spring. The rotary motion of the cam is applied as an oscillating motion to the codebar reset lever. The codebar reset lever in turn applies its motion to the codebar reset ball which oscillates from right to left when viewed from the front of the unit.

4.35 There are ten codebars in the codebar mechanism illustrated in Figure 15. The function of the codebars is to sense the marking and spacing positions of the blocking levers. As the reset bail pivots, the codebars move up and to the left to sense the positions of the blocking levers. If a blocking lever is down (spacing) a projection on the blocking lever comes in contact with a projection on the codebar, keeping it in a down position. The operation of individual codebars will be described in succeeding paragraphs in conjunction with other mechanisms. Function levers positioned under the codebars and stop slides riding the top of the codebars will be described later.

4.36 Early in the codebar cycle a trip cam pivots a follower arm which trips the function clutch. Near the end of the cycle the cam, through the reset lever, pivots the reset bail to the left. This allows the codebars to return to their stop (down and right) position.

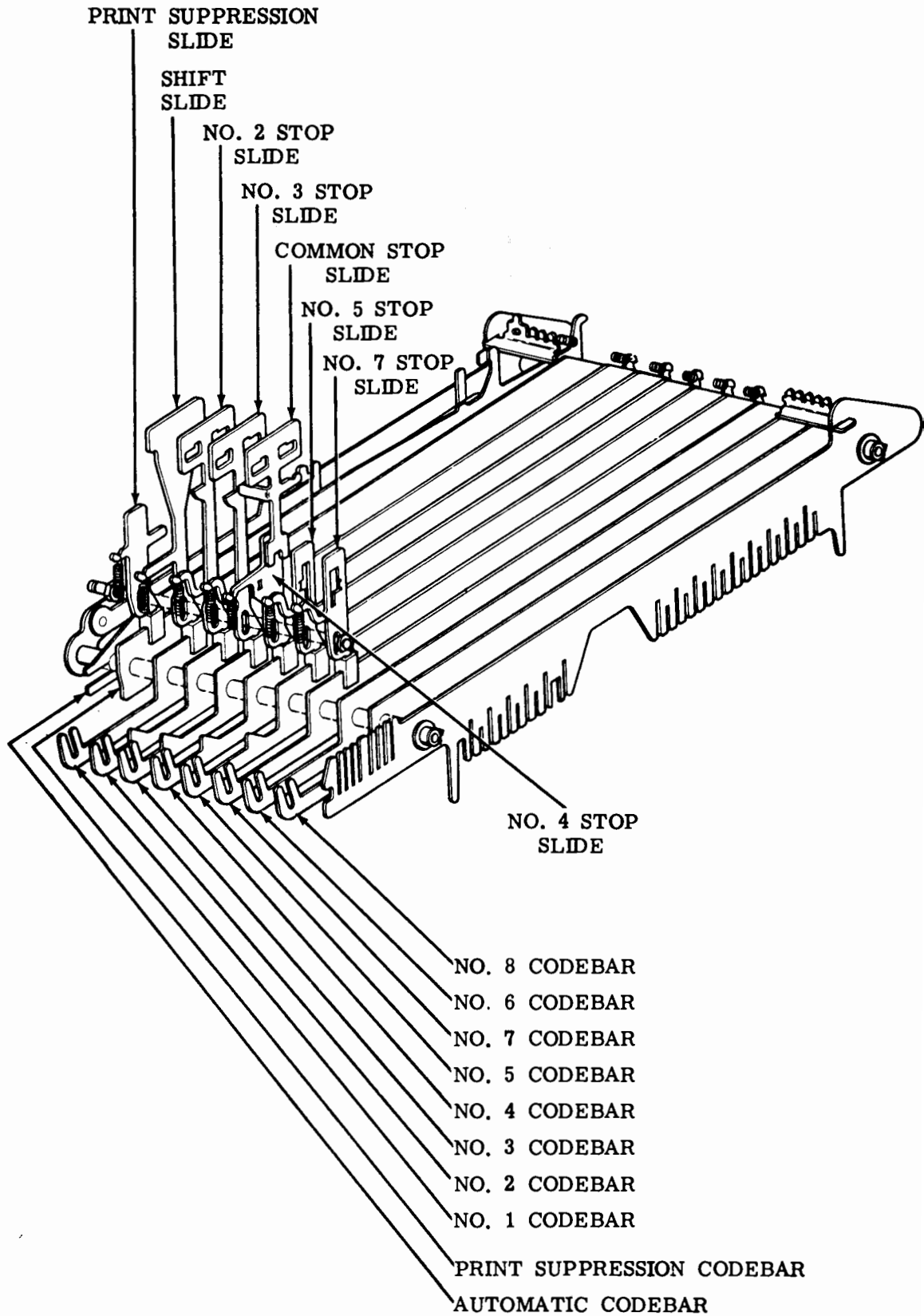

(Front Left View)

Figure 15 - Codebar Arrangement

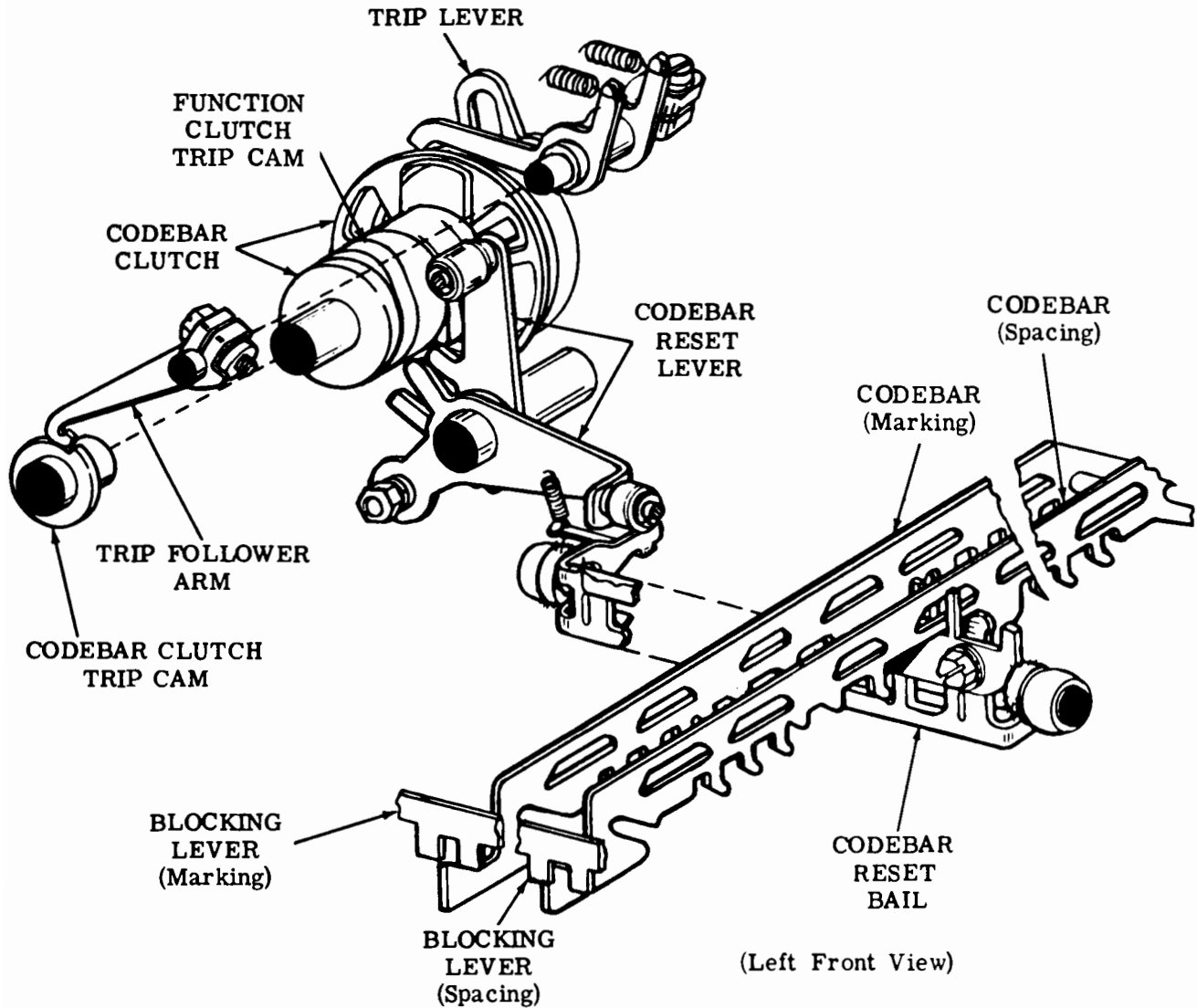

Figure 16 - Codebar Mechanism

I. Function Mechanism

4.37 The function mechanism illustrated in Figure 17 enables the typing unit to perform functions at the receipt of the proper code combinations. Functions are operations supplementary to printing the message, such as carriage return and line feed.

4.38 Early in the codebar cycle a cam pivots the function trip follower arm, which moves the function trip lever out of engagement with its shoe lever. The function clutch engages and makes one complete revolution. The function drive cam, through a follower arm and drive arm, causes the function rocker shaft to rock. The function rocker shaft, through two

drive linkages, moves a function drive bail up during the first part of the cycle and down during the middle portion.

4.39 The underside of the codebars are coded by a series of notches and projections. Under the codebars are a number of function levers which pivot on the same shaft as the function drive bail, and are connected to the bail by springs. As the bail moves up, the springs pull the function levers up so they sense the codebars. If a lever encounters one or more projections, it is retained in its down position against the tension of its spring. If the slots line up such that an opening is provided for a function lever, the lever moves all the way up to its selected position.

SECTION 574-122-100TC

4.40 In most cases, when a function lever moves up to a certain level, it is latched by an associated function pawl. Then, when the function drive bail pulls the lever and latched pawl down during the middle portion of the cycle, the pawl provides the motion to effect the function.

4.41 Near the beginning of the function cycle, a cam pivots a drive arm which moves the function stripper bail frontward. Near the

end of the cycle the cam permits the drive arm, under spring tension, to move the stripper bail rearward and strip any latched function pawls from their selected function levers.

4.42 The operation of the individual function levers and pawls is covered under the individual functions.

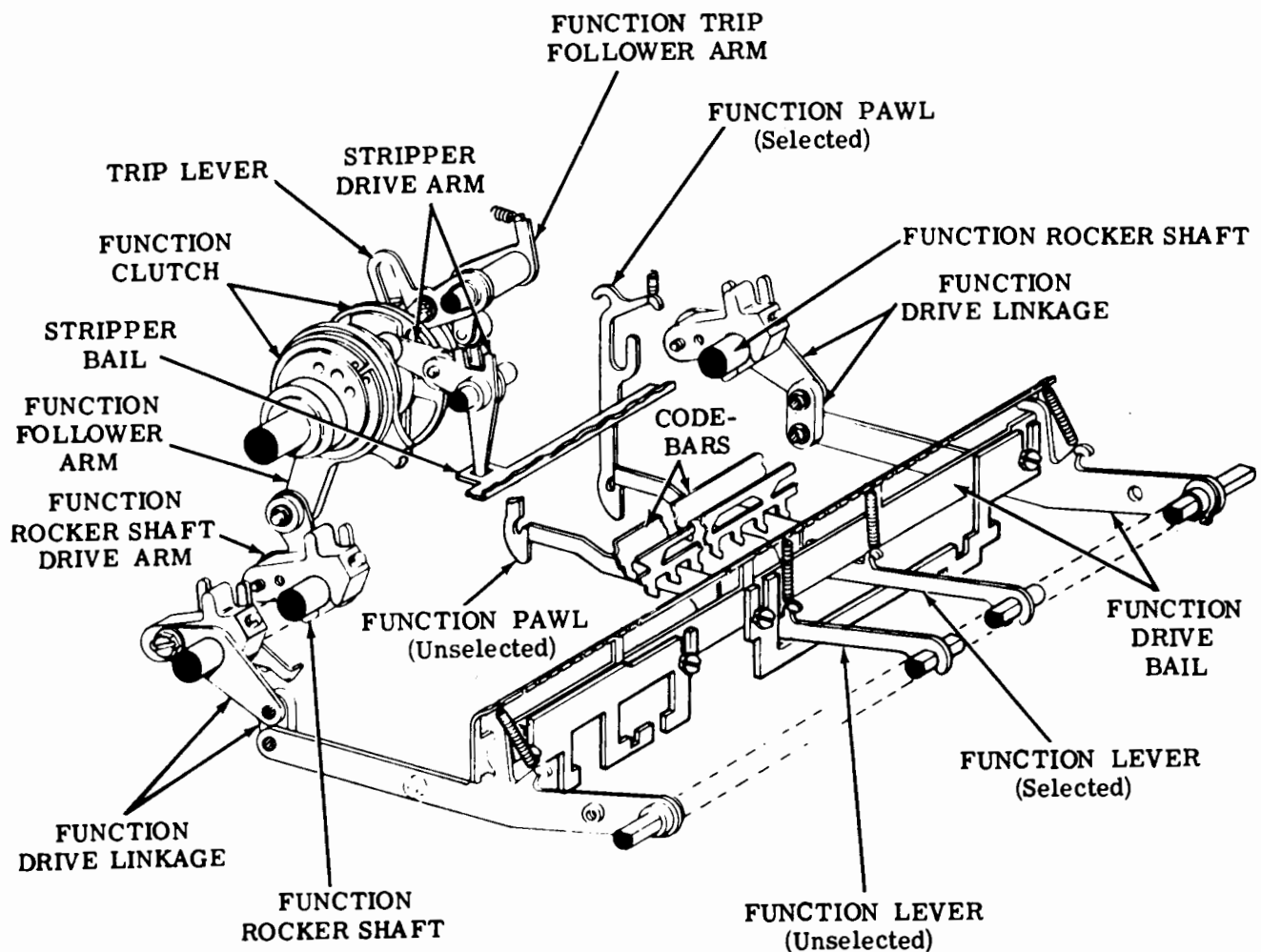

(Left Front View)

Figure 17 - Function Mechanism

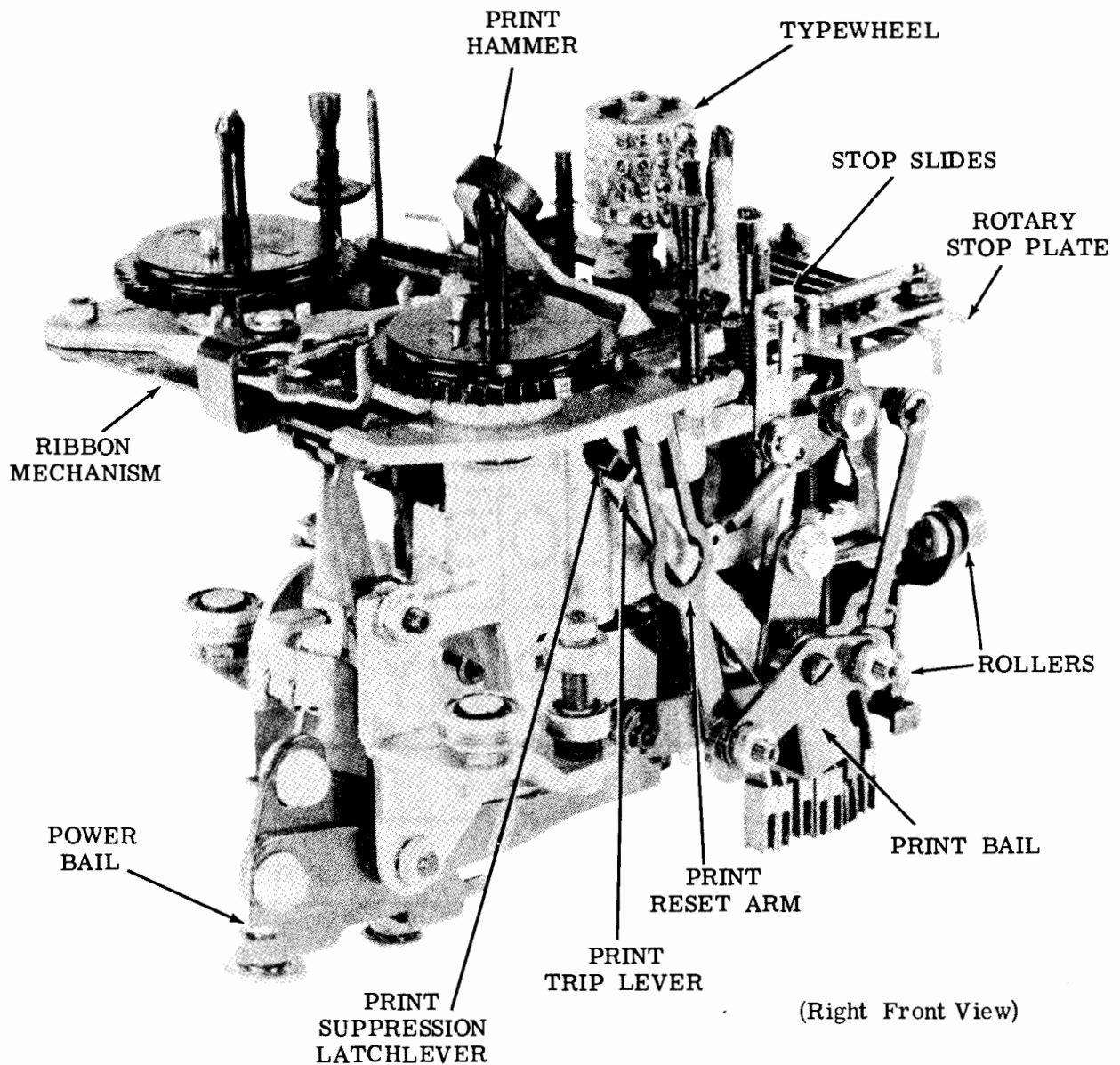

Figure 18 - Print Carriage

J. Printing

General

4.43 The printing of characters on paper is accomplished by the print carriage shown in Figure 18.

Typewheel

4.44 The characters used in printing are embossed on the cylindrical surface of a typewheel. A typewheel character arrangement

is shown in Figure 19, in which the cylindrical surface is rolled out flat. The characters are arranged in 16 vertical rows of 4 characters each. For the sake of explanation, the typewheel is divided into clockwise and counter-clockwise fields to indicate in which direction the typewheel is rotated to select the rows. The rows are then numbered 1 through 8 in each direction from the borderline between the fields. The characters in each row are designated the "1st" through the "4th" from top to bottom.

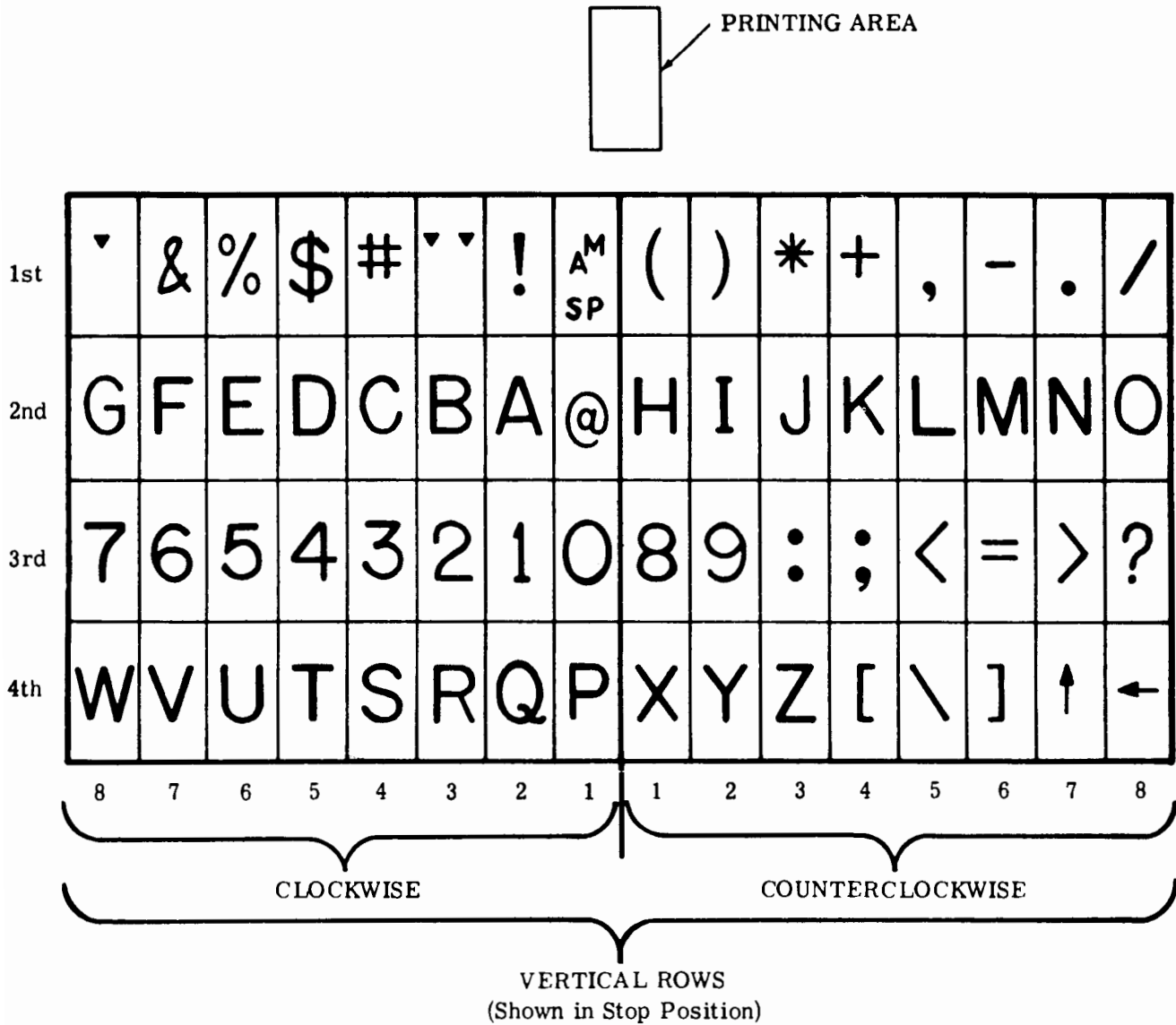

Figure 19 - Typical Typewheel Character Arrangement (As Printed)

4.45 Again for the sake of explanation, a printing area is indicated in Figure 19. This is the area the selected character must be in if it is to be printed when the print hammer strikes the typewheel against the platen. As shown in Figure 19 the borderline between the fields is under the printing area when the typing unit is in the stop condition. During the first part of each function cycle, vertical and rotary positioning mechanisms impart separate but simultaneous motions to the typewheel to select the proper character. The rotary mechanism rotates it either clockwise or counterclockwise to align the proper row with the printing area. The vertical mechanism raises it to place the proper character in the printing area. During

the latter part of the function cycle, the typewheel is returned to its stop position.

Power

4.46 As the function clutch rotates (4.36) an eccentric cam imparts oscillating motion through a carriage drive link to the carriage drive bail (Figure 5). The bail pivots rearward during the first part of the cycle and forward to its stop position during the latter part. In doing so, it causes a power bail on the carriage to pivot first clockwise (as viewed from the left), then counterclockwise (Figure 19). The power bail has two rollers that move along the drive bail and permit it to receive the motion regardless of the carriage position along the printing line.

Rotary Positioning

4.47 The rotary positioning mechanism is illustrated in Figure 20. The direction in which the typewheel rotates from the stop position is determined by the no. 4 codebar. If the no. 4 codebar is marking the typewheel rotates counterclockwise. If it is spacing the typewheel rotates clockwise.

4.48 When a code combination is received in which the no. 4 intelligence pulse is marking, the no. 4 codebar moves up and to the left. A slide mounted on the codebar, through a linkage, pivots the rotary drive arm down. The rotary drive arm has alternate tabs at the end. With the no. 4 codebar marking and the arm pivoted down, the upper left tab engages the left rotary rack. If the no. 4 intelligence pulse is spacing, the no. 4 codebar is down, the rotary drive arm is pivoted up, and the lower right tab engages the right rack.

4.49 A rotary drive bail is held against the power bail by a spring. As these bails rock clockwise (as viewed from the left) during the first part of the function cycle, the drive arm, which is attached to the rotary drive bail, moves toward the front. If the rotary drive arm is down (marking), it pulls the left rack with it, causing a rotary pinion, a cage, a spider, a shaft, and the typewheel to rotate counterclockwise (as viewed from the top). If the rotary drive arm is up (spacing), it pulls the right rack, rotating the pinion, cage, spider, shaft, and typewheel clockwise. As the power bail and rotary drive bail rock back to their stop position during the latter part of the function cycle, two reset blocks on the drive bail return the racks and the typewheel to their stop position.

Degree of Rotation

4.50 How far the typewheel rotates in either direction is determined by the no. 1, no. 2, and no. 3 codebars.

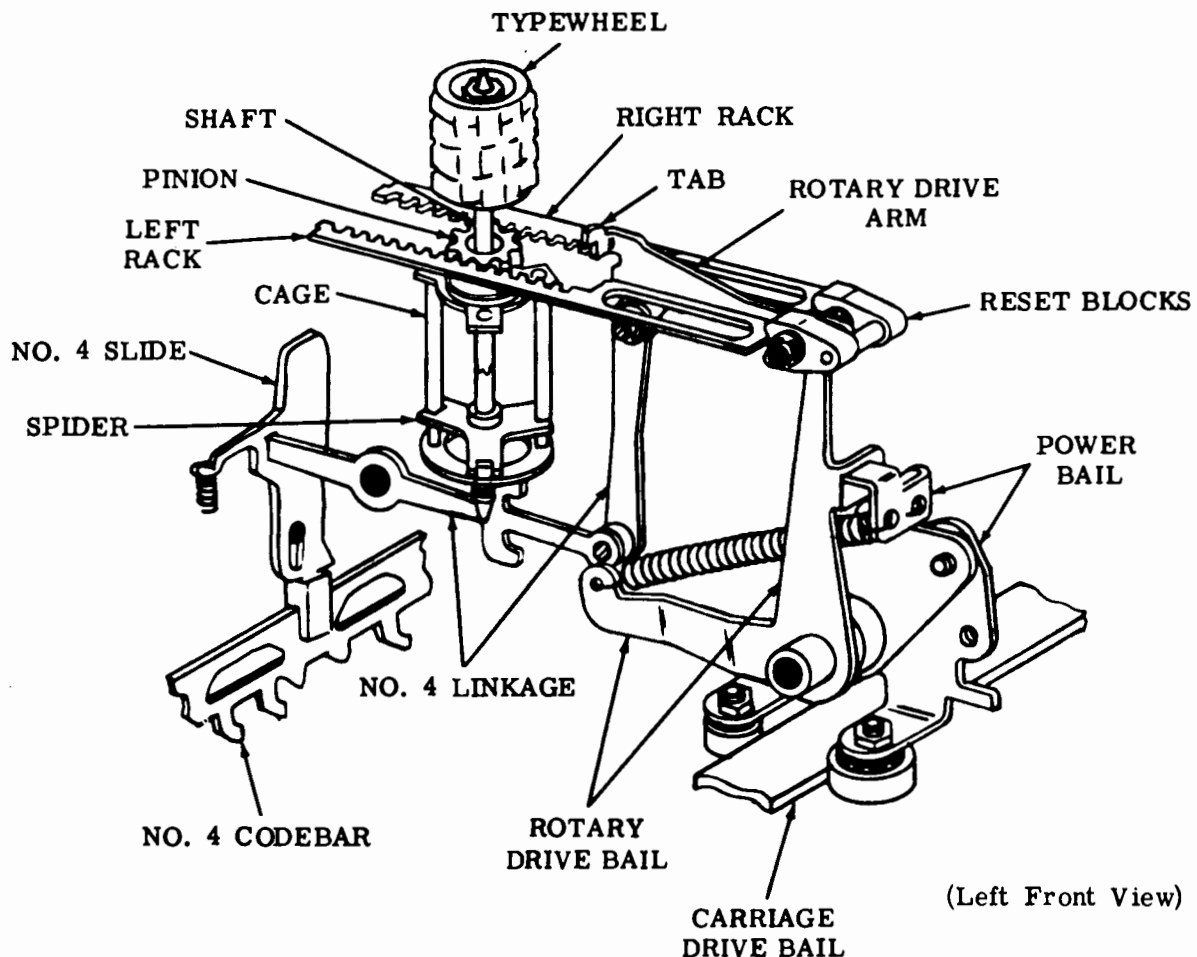

Figure 20 - Rotary Positioning Mechanism

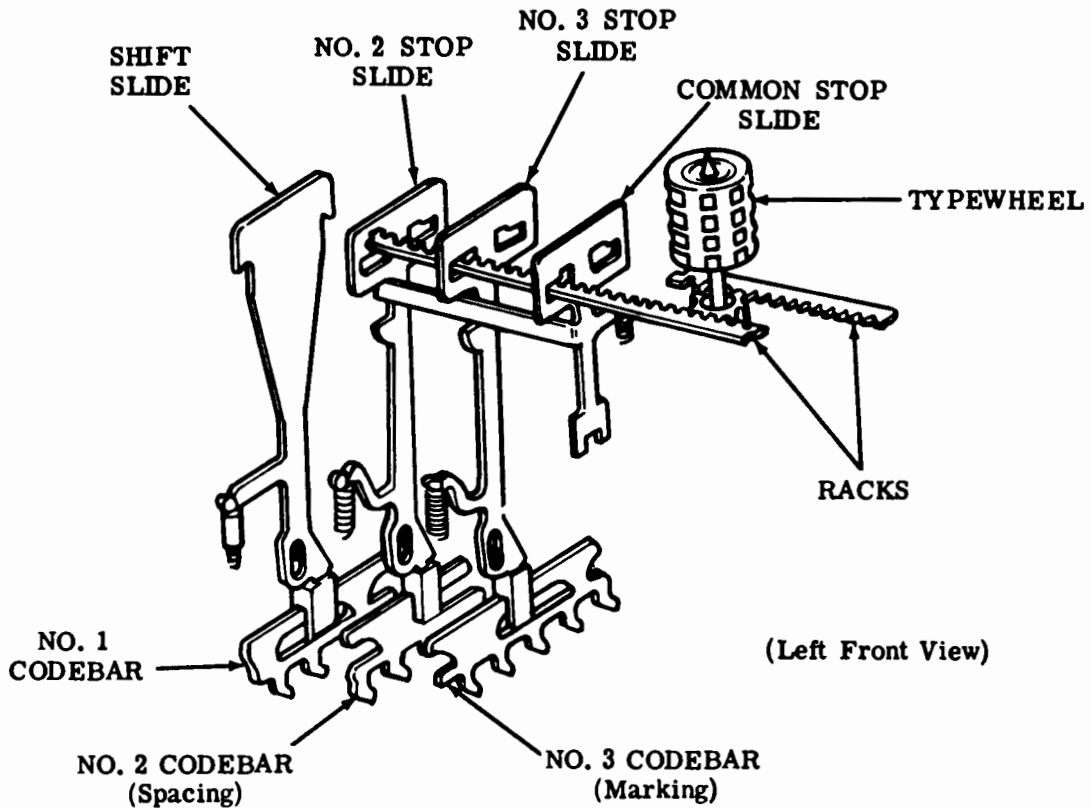

Figure 21 - Rotary Positioning Stop Slides

4.51 The no. 1 codebar controls the position of the shift slide. The no. 2 and no. 3 codebars control the positions of the no. 2, no. 3, and common stop slides. These stop slides ride the codebars and are up when the codebars are marking and down when the codebars are spacing (Figure 21).

4.52 The function of the stop slides is to stop either rack in its rearward travel. When a rack is stopped, the rotary drive bail stops, and the continuing motion of the power bail is dissipated by the spring.

4.53 The position of each stop slide determines how much the rack will travel before it is stopped. When a stop slide is down, it blocks the rack; when it is up, the rack will pass through a slot in the slide and continue to travel until blocked by another slide. The shift slide has no slot. It will block the rack whether it is up or down (Figure 21).

4.54 Depending on the position of the shift slide, the rack will travel to position either the odd or even rows of the typewheel. When the shift slide is up, the even rows are

selected; when it is down the odd rows are selected. As mentioned in 4.51, the shift slide is controlled by the no. 1 codebar.

4.55 When the no. 1 pulse is spacing, the no. 1 codebar and thus the shift slide are down. In this position the shift slide is blocked by the front stop surface of the rotary stop plate (Figure 22). The no. 2, no. 3, and common stop slides remain locked in the slots of the slide guideplate. The corresponding positions of the shift slide, the no. 2, no. 3, and common stop slide will effect 7, 5, 3, and 1 rows of typewheel rotation respectively.

4.56 When the no. 1 pulse is marking, the no. 1 codebar and thus the shift slide are up. In this position the shift slide is up, blocked by the rear stop surface of the rotary stop plate (Figure 22). The two slide guideplates, under spring tension, move to the rear. This positions all four stop slides to the rear enough to reflect one additional row of typewheel rotation. Thus the shift slide, the no. 2, no. 3, and common stop slides will effect 8, 6, 4, and 2 rows of typewheel rotation respectively.

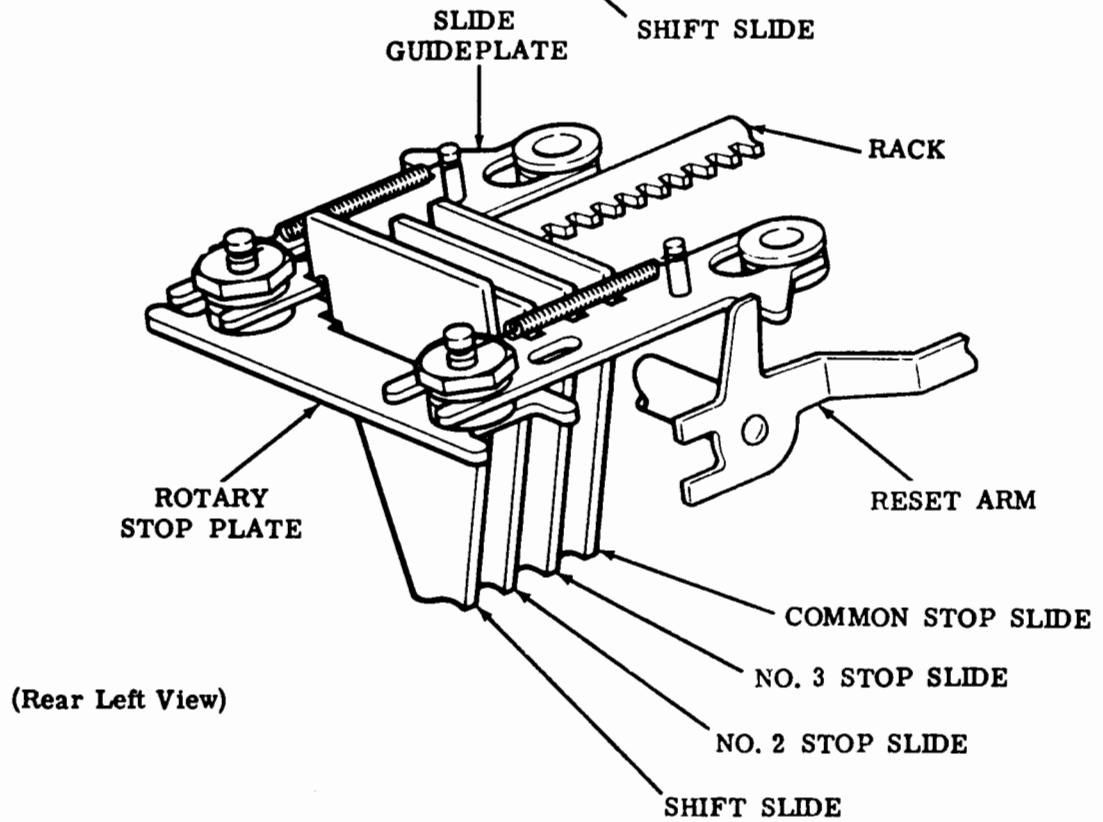
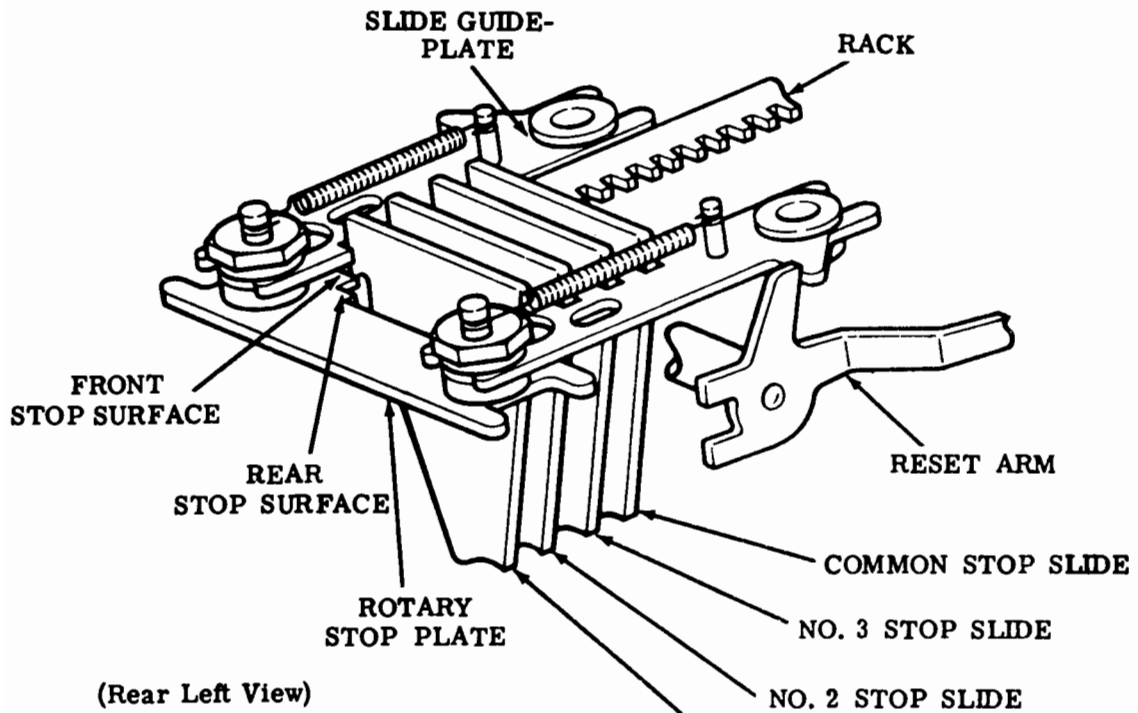

Figure 22 - Rotary Positioning Mechanism

4.57 Following is a summary of marking and spacing conditions for rotary positioning:

(a) Clockwise Field — No. 4 Pulse Spacing

Odd Rows - No. 1 Pulse Spacing

Row 1 — 2 spacing
 3 spacing
 common spacing } stop slides

Row 3 — 2 marking
 3 spacing
 common marking

Row 5 — 2 spacing
 3 marking
 common marking

Row 7 — 2 marking
 3 marking
 common marking

Even Rows - No. 1 Pulse Marking

Row 2 — 2 spacing
 3 spacing
 common spacing

Row 4 — 2 marking
 3 spacing
 common marking

Row 6 — 2 spacing
 3 marking
 common marking

Row 8 — 2 marking
 3 marking
 common marking

(b) Counterclockwise Field — No. 4 Pulse Marking

The marking and spacing conditions of the stop slides are the same as for the clockwise field.

Vertical Positioning

4.58 The vertical positioning mechanism illustrated in Figure 23 positions the typewheel so that the proper character in the selected row is in the printing area at the time of printing.

4.59 Vertical positioning is determined by the no. 5 and no. 7 codebars with their associated no. 5, no. 7, and common stop arms.

4.60 A vertical drive bail is held against the power bail by a spring. When these bails rock clockwise (as viewed from the left) during the first part of the function cycle, the vertical drive bail, through a drive arm, lifts the spider, typewheel shaft, and typewheel. How far the typewheel is raised is determined by three stop arms that are positioned in response to the no. 5 and no. 7 pulses. When the drive bail encounters an arm, it is stopped and its spring extends as the power bail continues to pivot. The spider moves up and down the bars of the cage, and thus permits rotary motion to be transferred to the typewheel regardless of its vertical position.

4.61 When a code combination is received in which the no. 5 and no. 7 pulses are spacing, the no. 5 and no. 7 codebars and their respective vertical slides remain down, spacing, and no motion is transferred to the stop arms. As the rear extension of the vertical drive bail rises, it strikes the common stop arm, which is the longest. This permits the typewheel to be raised to the point where the first character in the selected row is in the printing area at the time of printing.

4.62 When the no. 5 pulse is spacing and the no. 7 is marking, the no. 7 codebar moves its vertical slide up. The slide pivots the common and the no. 7 stop arm rearward, out of the way of the drive bail. The bail thus strikes the no. 5 arm (the second longest), and the second character in the selected row is placed in the printing area.

4.63 When the no. 5 pulse is marking and the no. 7 is spacing, the no. 5 slide pivots the no. 5 and common stop arms out of the way. The bail strikes the no. 7 stop arm (the shortest) and the third character is placed in the printing area.

4.64 When both the no. 5 and no. 7 pulses are marking, all three stop arms are pivoted out of the way. The bail moves up until it strikes the shoulder on the common stop arm, and the fourth character is placed in the printing area.

Printing Mechanism

4.65 After the typewheel has been positioned during the first half of the function cycle, the printing mechanism illustrated in Figure 24 supplies the impact which drives the selected character against the ribbon and paper. Provisions are included whereby printing is suppressed during functions.

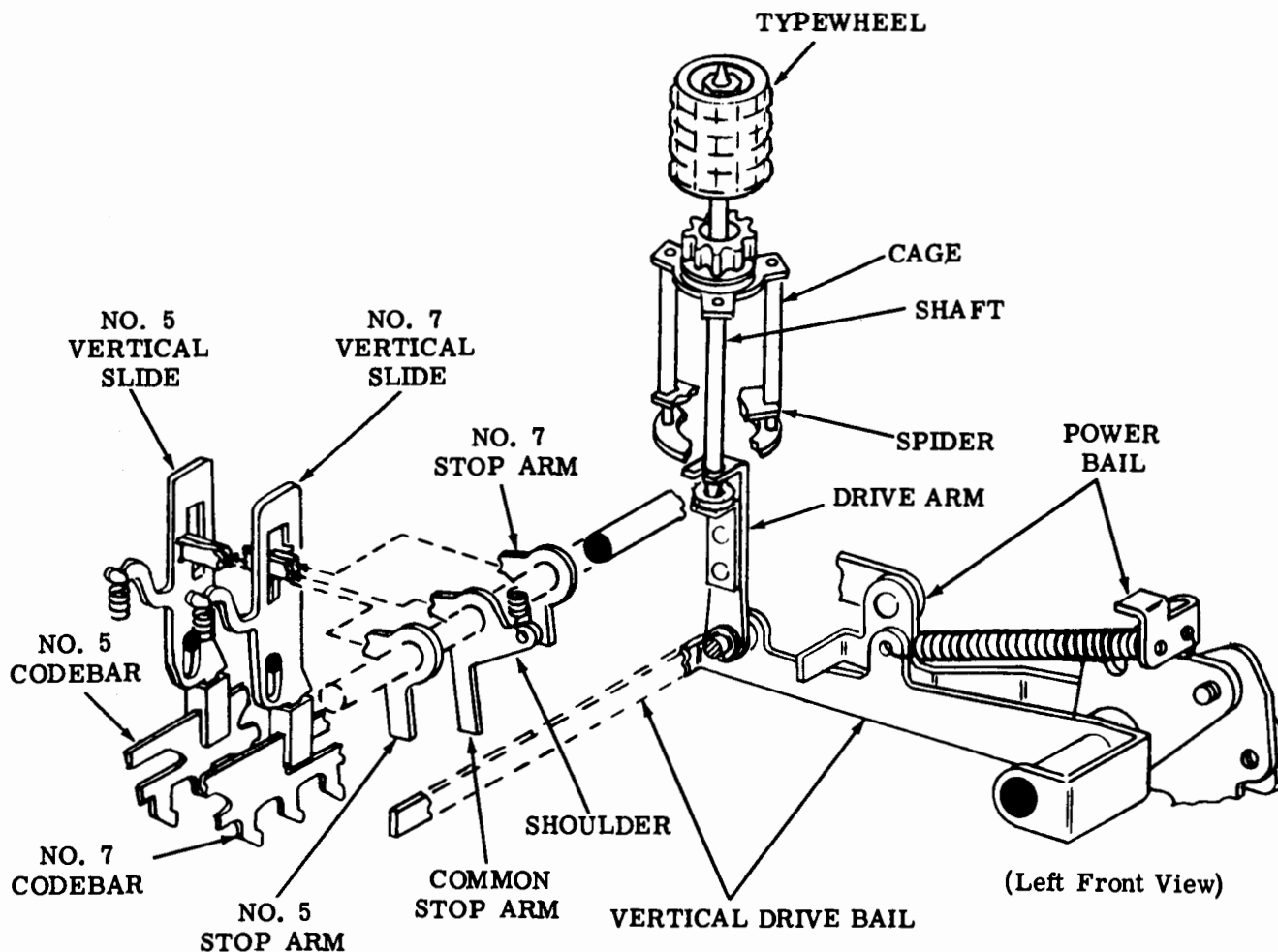

Figure 23 - Vertical Positioning Mechanism

4.66 As the power bail rocks during the first part of the function cycle, it imparts through a link clockwise motion (as viewed from the right) to a print bail. This bail, through a link and pivot shaft, pivots two reset arms. Midway in the cycle, the right arm moves a print trip lever out of engagement with a shoulder on the print hammer bail. A torsion spring snaps the hammer bail rearward, and the hammer drives the typewheel and ribbon against the paper. The lower end of the typewheel shaft pivots on the vertical drive arm and permits the wheel to be driven rearward. The hammer bail has a soft head which strikes the typewheel without damage.

4.67 During the last half of the cycle, the power bail returns the printing parts to their stop positions, and a print reset arm at-

tached to the print bail returns the print hammer bail to its stop position, where it is latched by the print trip lever.

K. Printing Suppressed

4.68 The print suppression mechanism (Figure 25) suppresses printing whenever a function code combination is received.

4.69 As the other codebars rise early in the codebar cycle, a print suppression codebar is held down by a print suppression latch. Early in the function cycle, after any of the function levers have been selected, the latch is pivoted away from the codebar by a print suppression cam on the function clutch.

4.70 If no function lever has been selected, the print suppression codebar moves up and to the left to its selected position. A print suppression slide follows the motion of this codebar and pivots a print suppression latch-lever out of the way of the shoulder on the print hammer bail. Thus, when the print trip lever releases the bail, its hammer is permitted to strike the typewheel and printing occurs.

4.71 If any function lever moves up to its selected position, it engages one of a series of notches in the print suppression codebar. When the latch releases the codebar, the selected function lever prevents it from moving all the way to its selected position. Thus, the print suppression latchlever is not pivoted and catches the shoulder when the hammer bail is

released by the trip lever. The hammer does not reach the typewheel, and printing is suppressed.

4.72 As the selected function lever moves down and withdraws from the notch in the print suppression codebar, the latch, which has been returned to its stop position, engages a second latching surface on the codebar. This prevents the codebar from rising when the function lever is withdrawn, thus causing printing to occur before the print hammer is completely reset in its stop position. The print suppression codebar is completely reset with the rest of the codebars at the end of the codebar cycle, and at that time the latch engages the first latching surface.

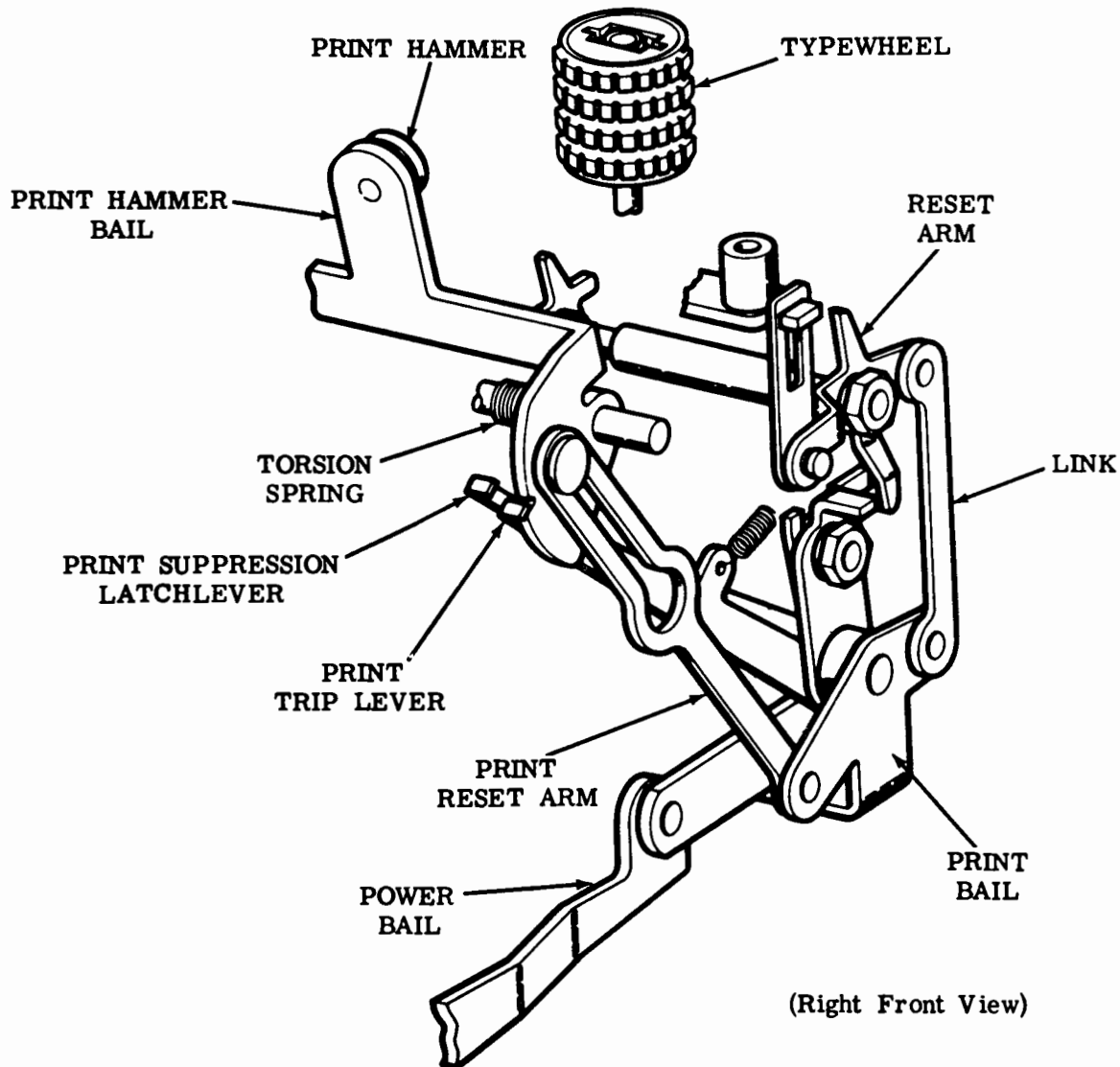

Figure 24 - Printing Mechanism

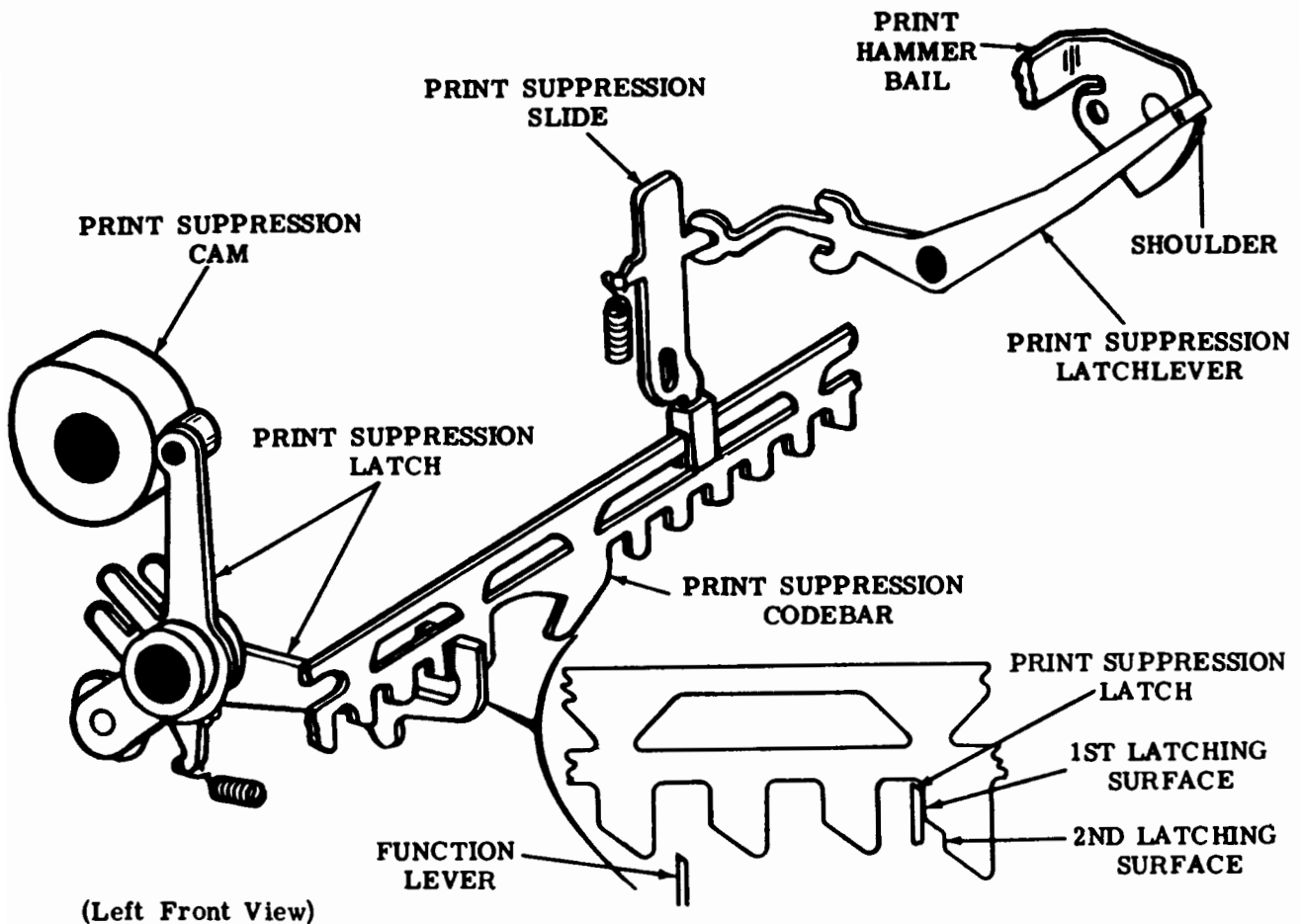

Figure 25 - Print Suppression Mechanism

L. Ribbon Mechanism

4.73 The ribbon mechanism (Figure 26) supplies the ink for printing. As the typing unit operates, the mechanism feeds the ribbon from one spool to the other, and reverses the direction of feed when the spool is nearly depleted.

4.74 As the power bail rocks during the first part of the function cycle, it pivots a ribbon power lever which moves a ribbon drive lever rearward. A feed pawl rides on the drive lever and acts on a ratchet to rotate a ribbon spool. A check pawl drops into the succeeding tooth and detents the ratchet until it is again rotated during the next operation.

4.75 The mechanism continues to rotate one spool until the other is nearly depleted. An eyelet in the ribbon then engages the ribbon reversing arm. As the eyelet is pulled against the arm, the latter moves to a point where a detent spring shifts it to its alternate position,

where one of its reversing extensions falls ahead of an extension on the feed pawl. As the pawl moves forward during the last half of the cycle, it strikes the arm extension and is pivoted to its alternate position against the other ratchet. In doing so, it strikes an extension on the check pawl and pivots it to its alternate position against the other ratchet. The depleted spool is now rotated to take up the ribbon until the other spool is nearly depleted, when reversal again takes place.

4.76 The ribbon guide, which is spring biased upward is mounted so that it will slide up and down on posts. As the print pivot shaft turns during the first half of the cycle, the two pivot arms permit the guide to rise so that it is between the selected character and the paper midway in the cycle. At this time the print hammer drives the typewheel and the ribbon against the paper. During the last half of the cycle, the pivot arms retract the guide and ribbon to their stop position so that the printed characters are visible.

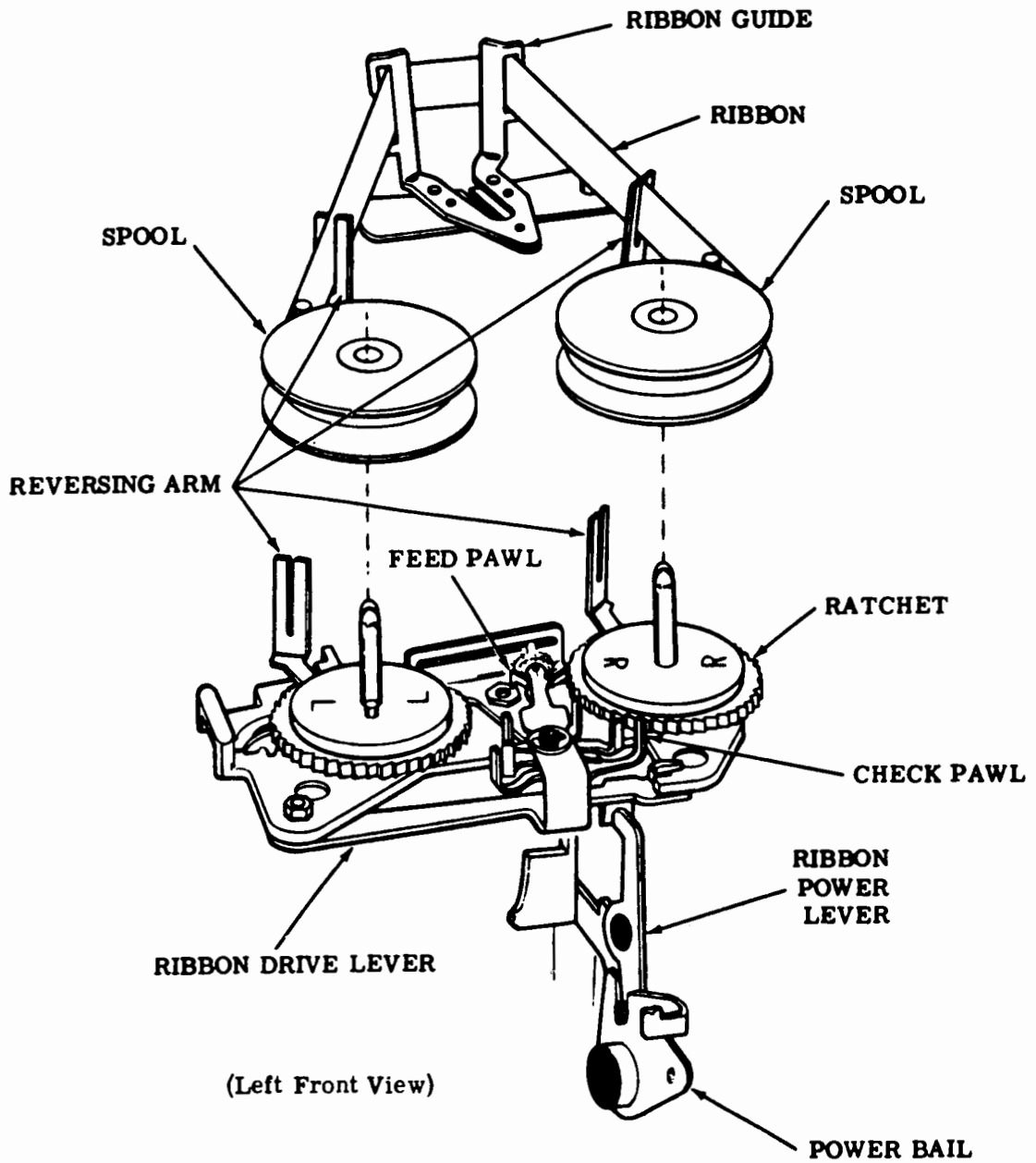

Figure 26 - Ribbon Mechanism

M. Spacing Mechanism

4.77 The spacing mechanism (Figure 27) positions the carriage so that the printed characters are horizontally in line on the paper. Each time a character is printed, the carriage is positioned one character to the right. Spacing is suppressed on all functions except "space" when spacing occurs and printing is suppressed. At the end of the printed line, spacing is sup-

pressed and the typing unit overprints. When the "carriage return" function is received, the carriage is returned to the left margin.

Note: With the automatic carriage return-line feed feature, spacing is not suppressed at the end of a line. Also, the typing unit does not overprint at the end of a line. The carriage is returned automatically to the left margin when it reaches a predetermined point.

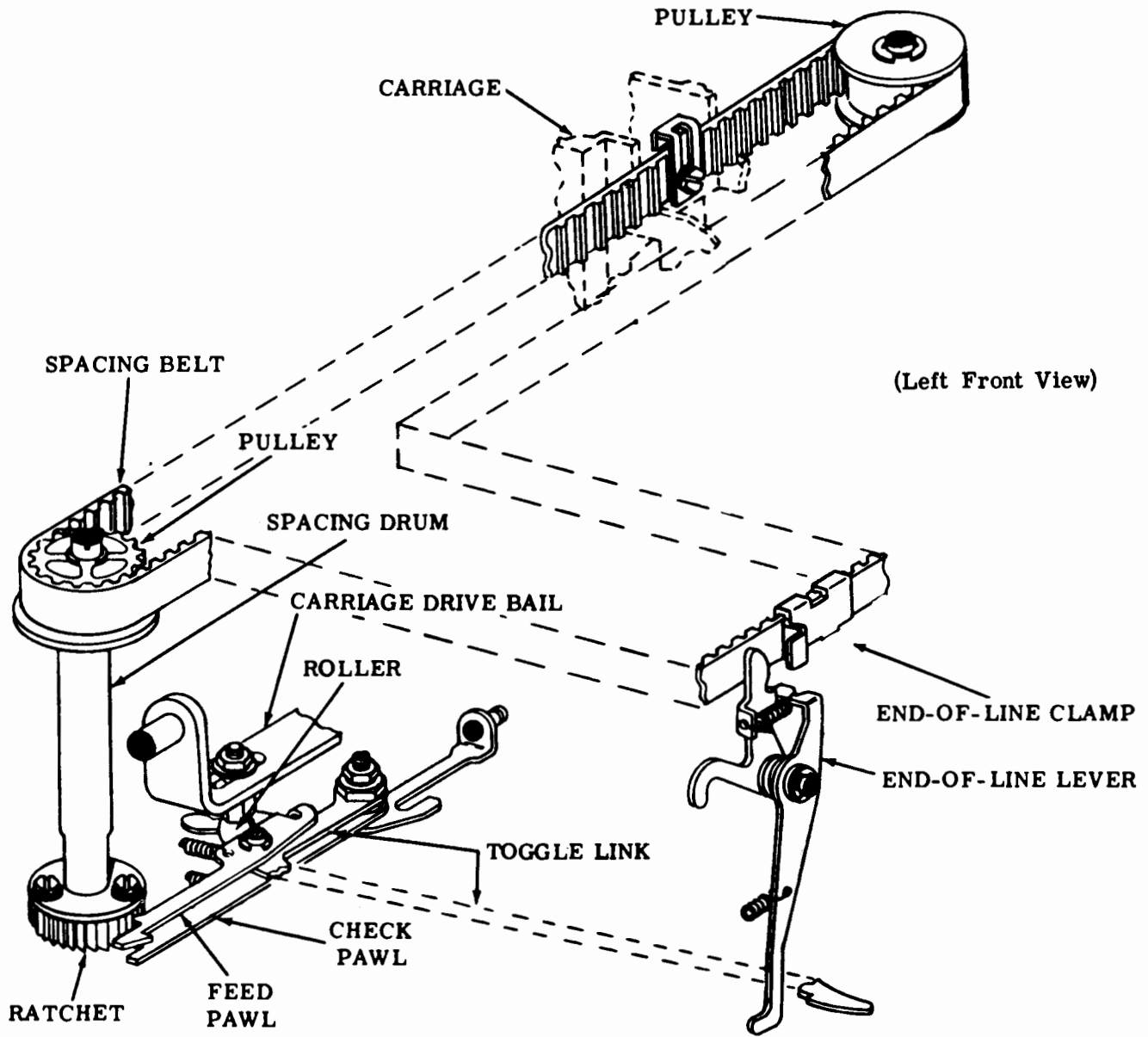

Figure 27 - Spacing Mechanism

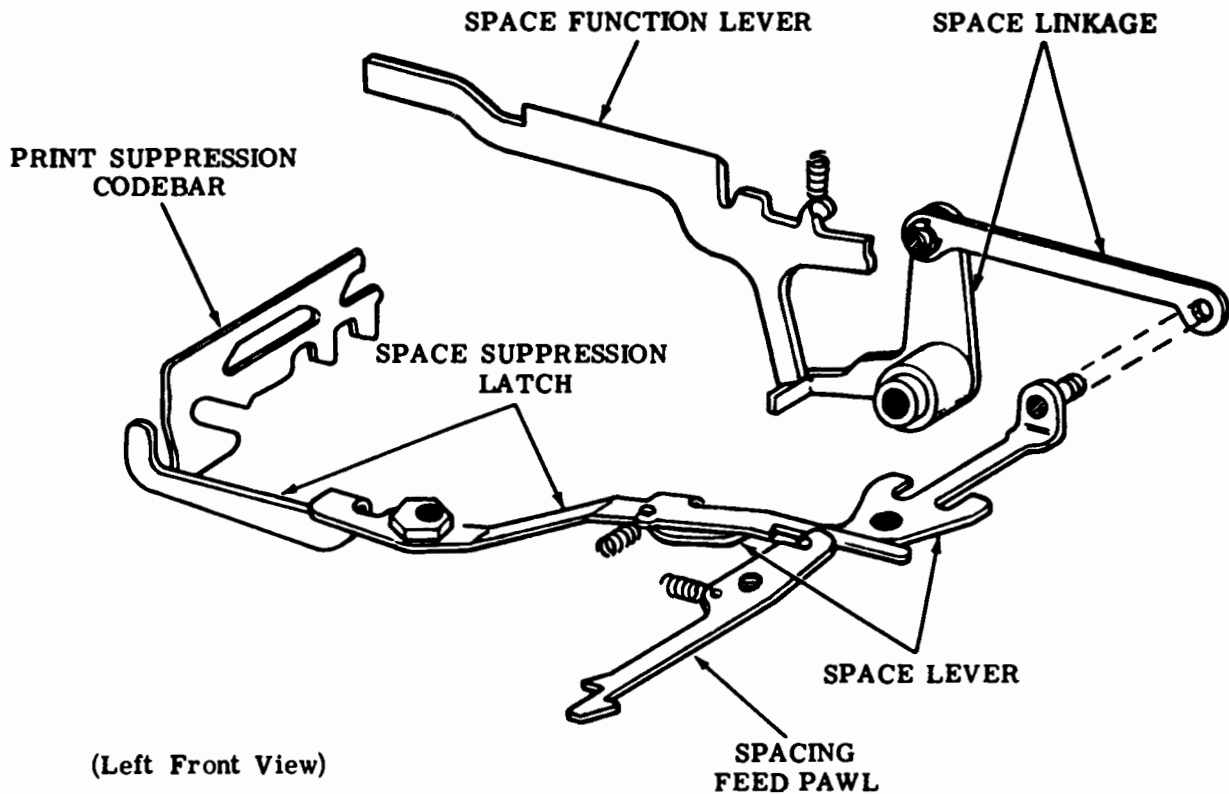

Figure 28 - Space Function and Space Suppression Mechanism

4.78 As the carriage drive ball moves rearward during the first part of the function cycle, a small roller mounted near the left end permits a toggle linkage consisting of a spacing feed pawl and toggle link to buckle rearward under spring tension. The feed pawl moves to the right and engages the next tooth on the ratchet. The ratchet is part of the spacing drum. When the roller moves towards the front during the other part of the cycle, it unbuckles the toggle linkage, and the pawl is moved to the left and rotates the drum one tooth. This motion is imparted by a pulley at the top of the drum to a spacing belt which is looped around a pulley on the right side of the typing unit. The spacing belt in turn moves the carriage to the right one space against the tension of a large carriage return spring. The carriage is held in this position by a check pawl, which engages the spacing drum ratchet.

4.79 When the "space" code combination is received, the codebars permit the space function lever to move up to its selected position early in the function cycle. This motion is transferred, through a space linkage, to a space lever which moves the print suppression latch

out of the way of the toggle linkage. The spacing linkage buckles completely and spacing takes place as described. Printing is suppressed as described in 4.68.

N. Space Suppression Mechanism

4.80 On Functions: On every function except "space," spacing as well as printing must be suppressed (Figure 28). When a character to be printed is received, the print suppression codebar moves up and to the left. In doing so it pivots a space suppression latch so that it is moved to the right, out of the way of the toggle linkage. This permits the linkage to buckle and effect spacing.

4.81 On the other hand, when a function is received, the print suppression codebar remains down and to the right, and does not pivot the space suppression latch. In this position, the space suppression latch engages the toggle linkage and prevents it from buckling all the way, and the feed pawl does not move far enough to engage the next tooth. Thus the spacing drum is not rotated, and the carriage is not spaced.

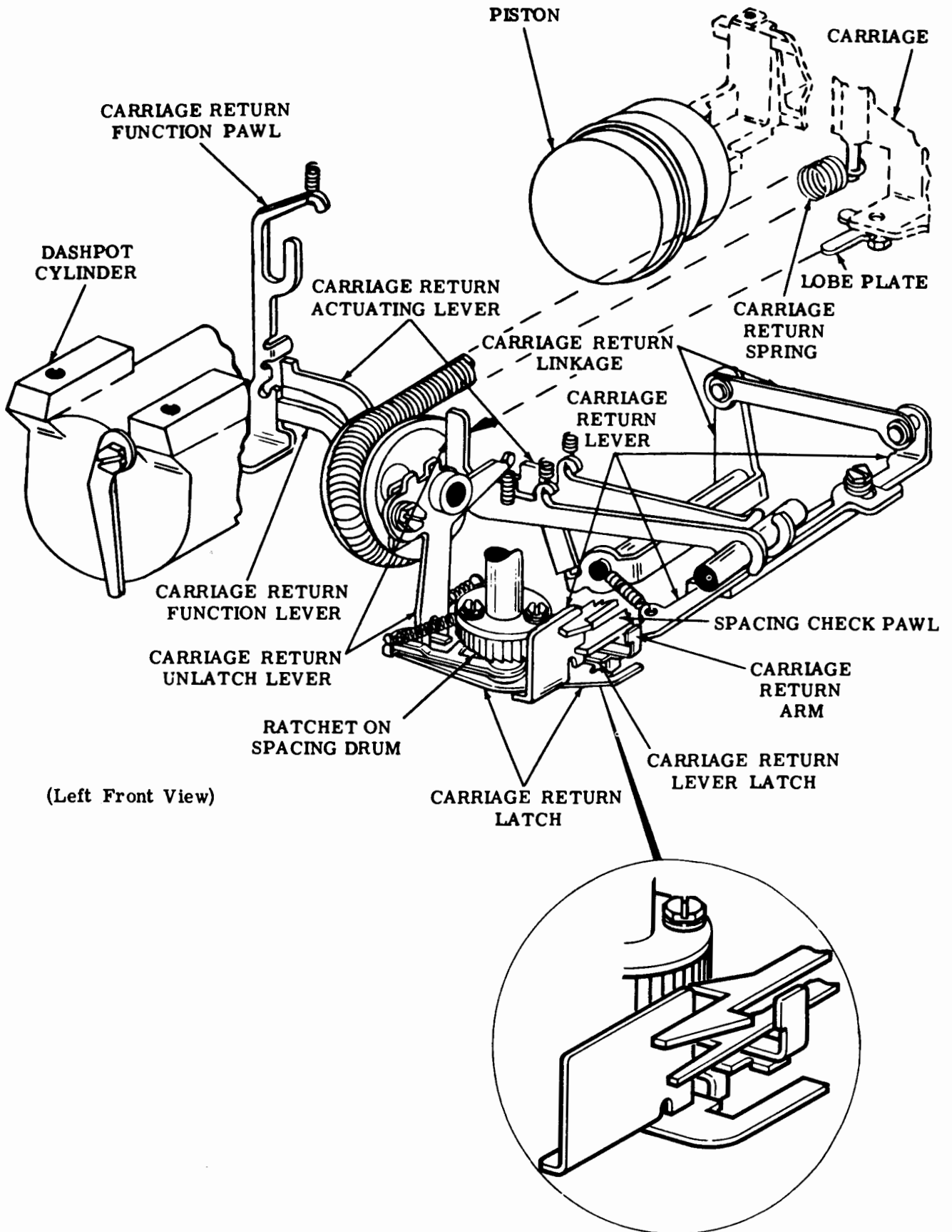

Figure 29 - Carriage Return Mechanism

4.82 **At End-of-Line:** When the carriage reaches the right margin, a clamp on the spacing belt pivots an end-of-line lever counterclockwise. In this position, a latching surface on the spacing toggle link engages the end-of-line lever and prevents the linkage from buckling and effecting spacing. Thus, spacing is suppressed, and the typing unit overprints at the right margin until the "carriage return" code combination is received.

Note: With the automatic carriage return-line feed feature, spacing is not suppressed at the end of a line. Also, the typing unit does not overprint at the end of a line. The carriage is returned automatically to the left margin when it reaches a predetermined point.

O. Carriage Return Mechanism

4.83 The carriage return mechanism is illustrated in Figure 29.

4.84 When the "carriage return" code combination is received, the carriage return function lever moves up to its selected position, and engages the carriage return function pawl. As the function bail moves the lever and pawl down during the middle portion of the cycle, an extension on the pawl drives the carriage return actuating lever down also. This motion is transferred by means of linkages to the carriage return lever. In moving forward the carriage return lever is latched by both the carriage return latchlever and carriage return latch.

4.85 In moving forward the carriage return lever also disengages the spacing pawl and check pawl from the spacing drum ratchet. The carriage return spring then pulls the carriage back to the left margin. As the carriage nears the left margin, a lobe plate on the carriage strikes the unlatch lever. This unlatches the carriage return lever and the carriage return latch. However the carriage return lever remains engaged by the latchlever and cannot move to the rear to allow the pawls to engage. When a code combination is received in which spacing is not suppressed, the carriage return lever allows the feed and check pawls to again engage the ratchet. This is accomplished by the feed pawl moving to the right and back to unlatch the carriage return arm and latchlever from the carriage return lever. The latter, under spring tension, moves toward the rear of

the unit allowing the pawls to engage the ratchet. Late in the function cycle the carriage return function pawl is stripped from its function lever by the stripper bail.

4.86 As the carriage approaches the left margin at relatively high speed, a piston on the carriage enters a dashpot cylinder and compresses the air ahead of it. The air forms a cushion which slows the carriage and then, as it escapes through a small, variable hole at the left end of the cylinder, permits the carriage to be stopped at the left margin without excessive shock.

P. Paper or Form Feeding

4.87 The paper feed mechanism used on friction feed typing units is illustrated in Figure 30.

4.88 The paper feed mechanism vertically positions the paper so that the printed characters are properly located in lines on the paper. It feeds the paper on receipt of the "line feed" code combination. It may be adjusted for either single or double line feed.

4.89 The paper feeds off a roll and is led around a platen that vertically positions it in front of the typewheel. A paper guideplate leads it down around the platen. A pressure roller, which sits in a cutout in the guide, holds the paper against the platen so that it feeds when the platen rotates. A curved wire shaft biases the pressure roller and the guideplate against the paper. The pressure is released by a lever on the right end of the shaft. The paper is held around the front of the platen by a wire guide and is led up out of the typing unit by a deflector guide. It can be manually fed by a knob on the left end of the platen.

4.90 When the "line feed" code combination is received, the codebars permit the line feed function lever to move up to its selected position early in the function cycle. The function lever, in turn, moves up a line feed blocking lever to engage the latching surface of a line feed drive link. As the left drive arm on the function rocker shaft moves down, a line feed arm engages the blocking lever and moves it down. This motion is transferred, through a line feed linkage, to a pawl which engages a ratchet on the left end of the platen. The pawl rotates the platen which feeds the paper up one or two lines depending on how the mechanism is adjusted.

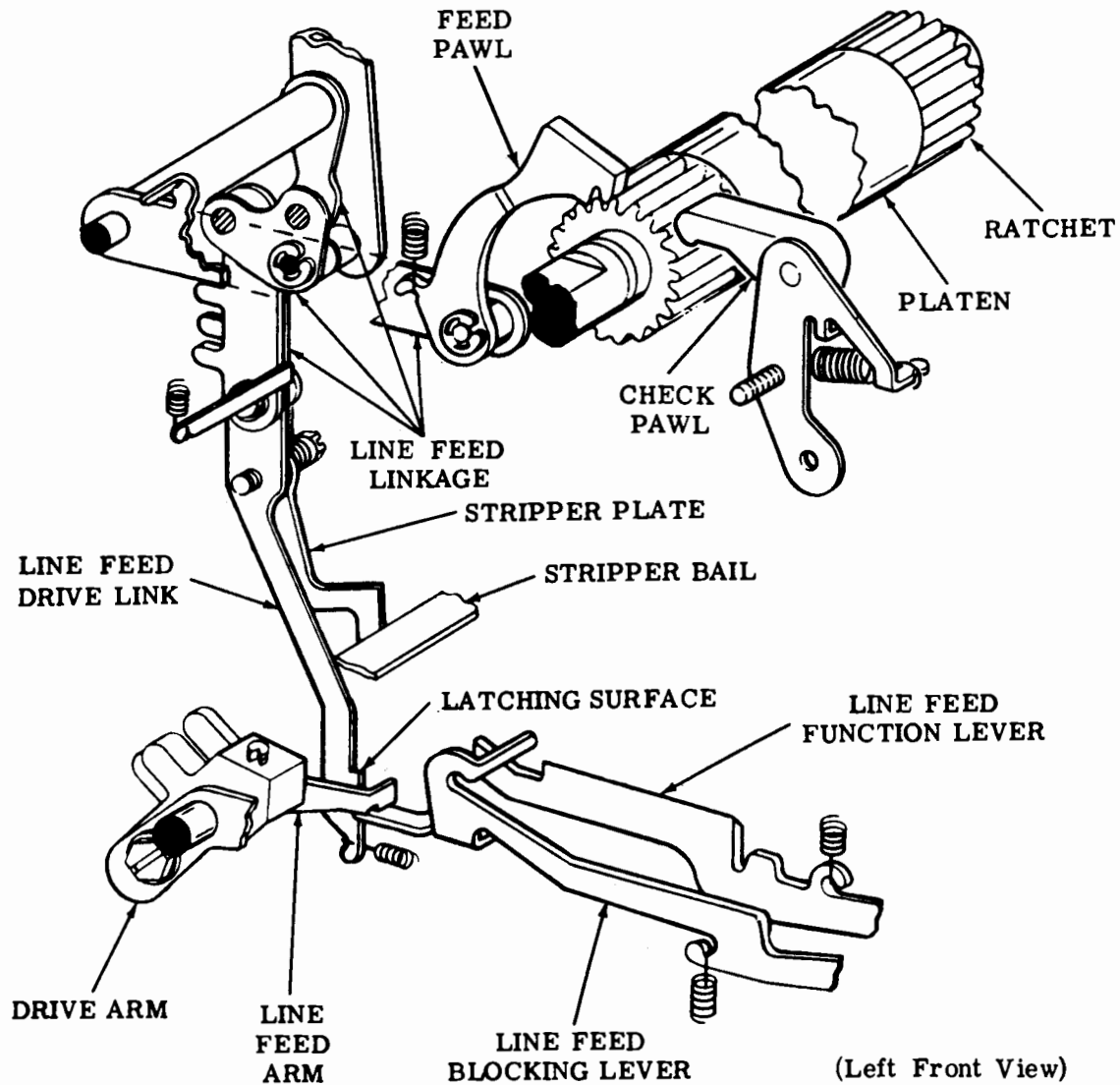

Figure 30 - Paper Feed Mechanism (Friction Feed)

4.91 The feed pawl is guided into the teeth of the platen ratchet by two posts. A check pawl riding on the ratchet at the left side of the platen holds the platen firmly until the platen is again rotated. At the end of the cycle, the function stripper bail contacts a stripper plate and strips the drive link from the blocking lever.

Q. Sprocket Feed Typing Units

4.92 The platen drive mechanism (Figure 32) rotates the platen for vertical positioning so that the printed characters are properly located in lines on the forms. The platen drive mechanism is activated through the form-out and form-feed mechanisms (Figures 31 and 33),

and controlled by the form-feed clutch. It feeds forms upon receipt of either the "line feed" or "form out" code combination and may be adjusted for single or double line feed.

4.93 Forms feed from a conveniently located stack of forms. They feed under a paper roll spindle and, if used, a low-paper arm and a paper-out arm. From here, the forms, led by a paper guideplate, engage sprocket pins and advance between the platen and two paper guides until vertically positioned in front of the type-wheel. The two paper guides and a wire guide hold the forms to the front of the platen and insure that the forms advance around the platen while moving up and out of the typing unit. As the forms move out of the typing unit, they go

over the paper roll spindle, which separates incoming from outgoing forms.

Note: Forms can be manually fed by depressing the center knob and rotating the platen knob located on the left end of the platen.

4.94 Form Feed: When the typing unit receives the "line feed" code combination, the line feed function lever (Figure 31) moves up to engage the line feed function pawl in slot

no. 13. The function pawl, by means of a lug, connects with the line feed strip pawl in the adjacent slot on the function casting (slot M). During the function cycle the function pawl engages and pulls down the strip pawl. The strip pawl pivots the line feed lever. An extension on the line feed lever contacts the trip lever extension which pivots the clutch trip lever away from the shoe lever on the form feed clutch. The clutch engages and the typing unit advances the form for single or double line feed by means of the platen drive mechanism.

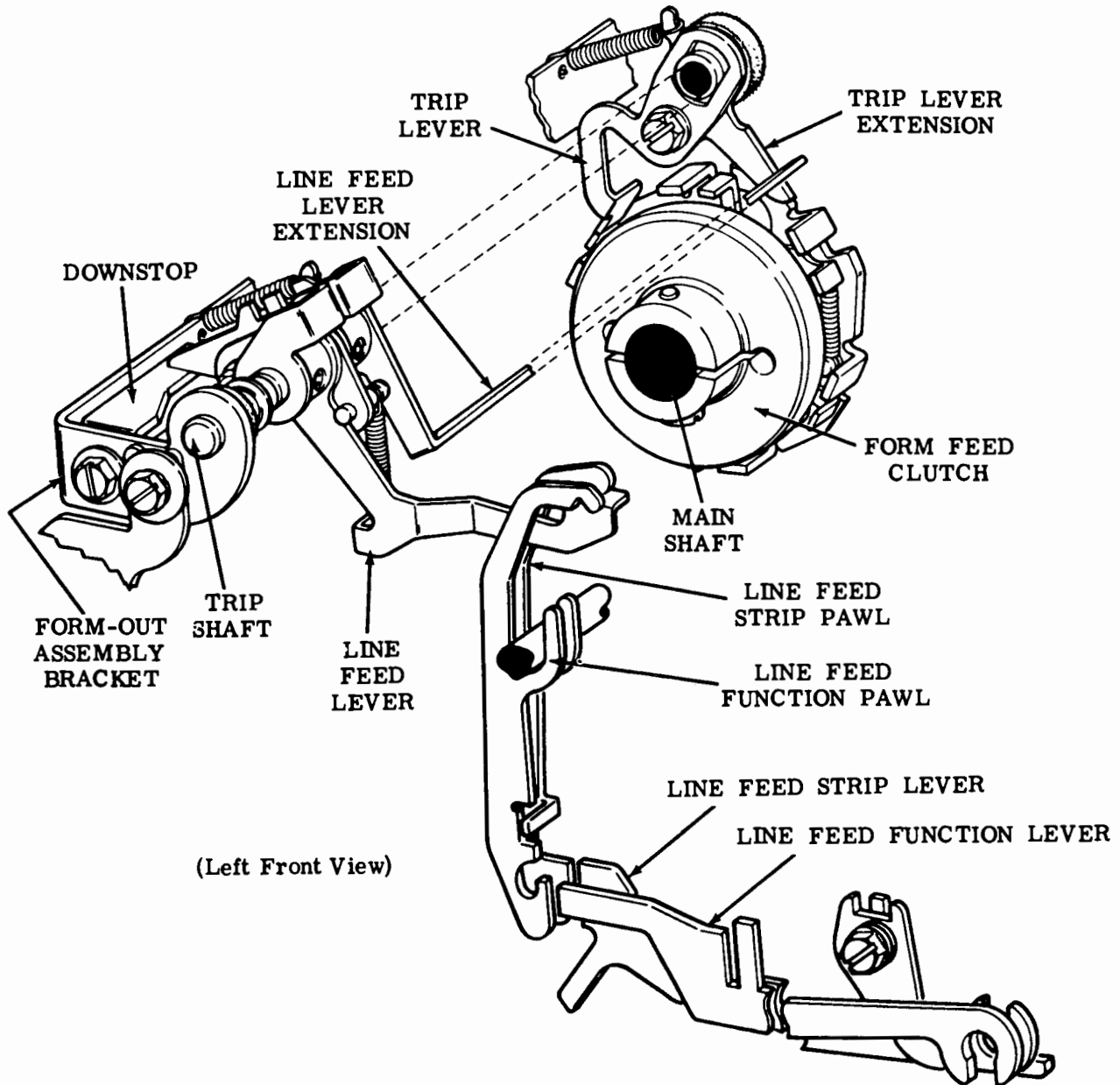
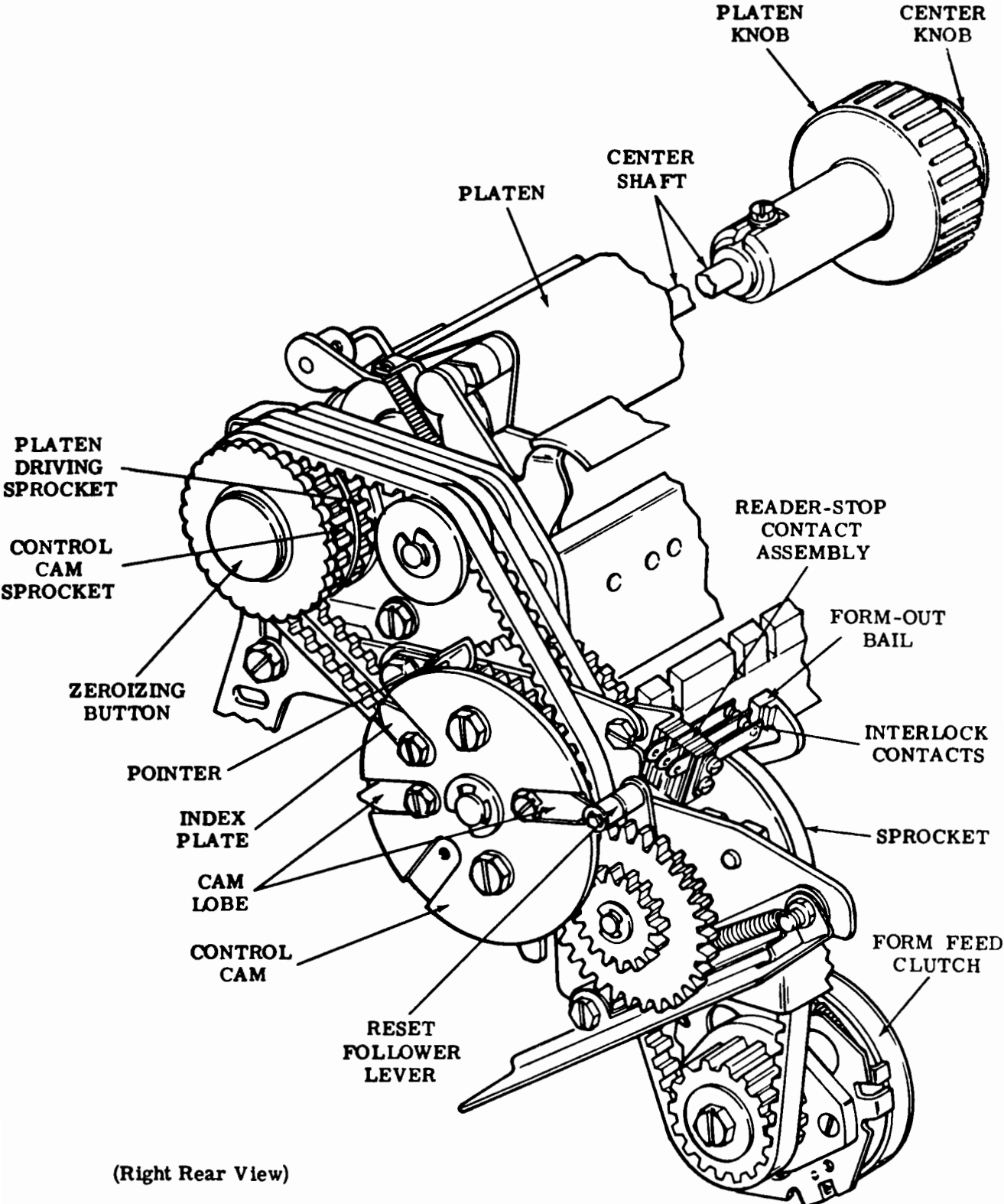

Figure 31 - Form-Feed Mechanism (Sprocket Feed)



(Right Rear View)

Figure 32 - Platen Drive Mechanism (Sprocket Feed)

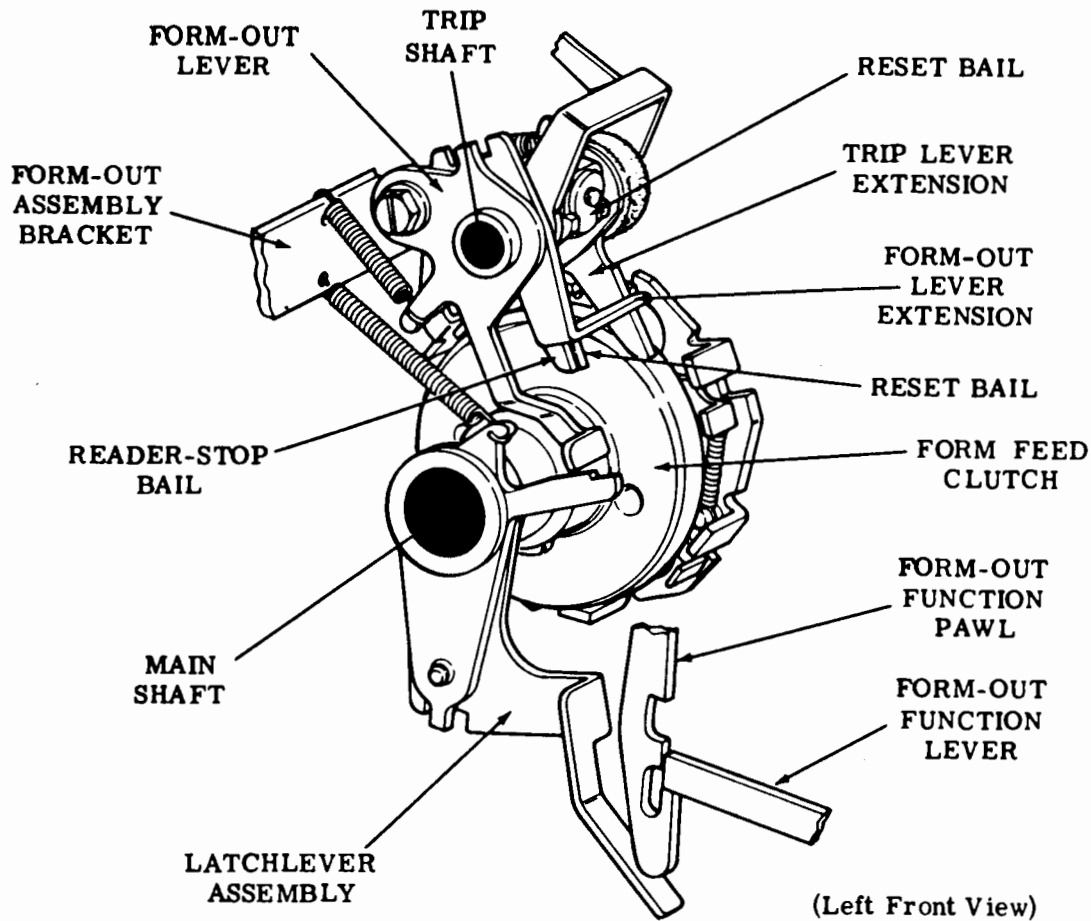

Figure 33 - Form-Out Mechanism (Sprocket Feed)

4.95 Late in the function cycle the strip pawl strikes the tail of the line feed strip lever and moves to the rear. The lug on the strip pawl moves the function pawl to the rear, disengaging it from the function lever. Due to spring tension the line feed lever and its extension return to their front position. The trip lever strikes the clutch shoe lever and the clutch is disengaged.

4.96 The number of lines the form advances depends on how much the clutch rotates before it is disengaged. If the clutch becomes disengaged at the first shoe lever, the form will advance one line; if the clutch becomes disengaged at the second shoe lever, the form will advance two lines; and so on. The amount of clutch rotation depends on how soon the strip pawl comes in contact with the line feed lever. This time will depend upon the distance between the strip pawl and the line feed lever. When the distance is small the clutch will trip and engage sooner, rotating a greater amount before it is disengaged. Double line feed will result. If the

distance is greater the clutch will trip and engage later, rotating a smaller amount before it is latched. Single line feed will result.

4.97 Form-Out: When the typing unit receives the "form out" code combination, the form-out function lever (Figure 33) moves up to engage the form out function pawl in slot no. 14. During the function cycle the pawl is pulled down. This action pivots the latchlever assembly which becomes disengaged from the form-out lever. Due to spring tension the form-out lever pivots to the rear. An extension on the form-out lever pivots the trip lever extension which in turn moves the clutch trip lever away from the clutch shoe lever. The form feed lever engages and remains engaged throughout the form-out cycle.

4.98 When engaged the clutch drives the platen drive mechanism which consists of belts, gears, and sprockets. The platen drive mechanism is illustrated in Figure 32.

4.99 As long as the form-out lever stays pulled to the rear by spring tension, the form will advance except as regulated by the control cam of the platen drive mechanism. Whenever the platen rotates, the control cam, being related to the platen by belts and gears, also rotates. The rotating cam, through cam lobes, a reset follower lever, and a reset bail initiates the action to terminate the advance of the platen and thus the form-out cycle.

4.100 When a cam lobe contacts the reset follower lever and rotates it toward the rear, a reset bail also rotates and pivots the form-out lever extension away from the trip lever extension. The trip lever engages a shoe lever and disengages the clutch, terminating form-out.

4.101 With the form-out just terminated the reset follower lever remains on the high part of a cam lobe, and the form-out lever is blocked by the reset bail from rotating to its latched position. When a "form feed" code combination is received, however, the control cam rotates and the reset follower lever moves from the high part of the cam lobe. This causes the reset bail to rotate downward and move away from the form-out lever extension. As a result, the form-out lever is permitted to latch. The typing unit can now receive another "form-out" command.

Note: It is in order to allow the cam lobe to clear the reset follower lever that a "form feed" command is given before another form-out cycle can begin.

4.102 The gearing on the platen drive mechanism varies to accommodate various size forms.

4.103 When the platen drive mechanism advances the form one or two lines during "form feed" the cam lobe rotates an equivalent distance. Then, when "form-out" is received the rest of the form will be advanced with the cam lobe merely rotating until it strikes the reset follower lever.

4.104 The control cam can have three lobes with the result that the form may be advanced one-third the distance for which the gears were installed. For example, if the gears on the platen drive mechanism were designed to advance a form of a certain length, by installing cam lobes, this length can be varied to smaller lengths.

4.105 When an Automatic Send-Receive Teletypewriter Set receives a "form-out" code combination, the form-out bail (Figure 32) is rotated toward the front by the form-out lever extension. This action causes the interlock contacts of the reader stop contact assembly to be operated with the following results:

(a) A pair of normally closed contacts are opened during the "form-out" function. This stops the tape reader from transmitting and prevents characters "on the fly" from being printed.

(b) A pair of normally open contacts are closed. This keeps the typing unit motor operating in case the typing unit is turned off before the form-out cycle is completed. Thus, synchronization of the forms is maintained.

4.106 The form can be manually advanced any length by pressing the zeroizing button on the platen (Figure 32). This will disengage the platen from the platen drive sprocket and allow it to rotate freely.

R. Margin Bell and End of Line Bell ←

4.107 Margin Bell: As the carriage moves to the right during printing, the carriage upper rear roller makes contact with and depresses a latch which is secured to a lever mounted on the rear rail. As the latch is depressed, the lever is rotated and moves the automatic carriage return-line feed codebar to the right a short distance, where a notch in the codebar permits the bell function lever to move up to its selected position, where it is latched by its function pawl. During the middle portion of the function cycle, the lever moves the pawl down against the pressure of the latter spring. When the stripper bail strips the pawl late in the function cycle, the pawl moves up and causes a clapper mounted on a wire spring to snap up and ring a gong.

4.108 End of Line Bell: End of line bell operation proceeds in the same manner as above, except that a projection on the carriage picks up the automatic carriage return-line feed codebar at a predetermined point and moves the codebar to the right a short distance until a notch in the codebar permits the bell function lever to move up to its selected position. ←

Automatic Carriage Return-Line Feed (Friction Feed)

4.109 As described for the end of line bell (4.108), the carriage picks up the automatic carriage return-line feed codebar at a predetermined point and moves it to the right. When the carriage reaches the right margin, a notch in the codebar permits an automatic carriage return-line feed function lever to move up to its selected position, where it is latched by its function pawl.

4.110 The automatic carriage return-line feed function lever, in turn, moves the line feed blocking lever up to where it is latched by the line feed link. Line feed then occurs as described in 4.87 through 4.91 and 4.94 through 4.96.

4.111 When the automatic carriage return-line feed function lever and its function pawl are pulled down during the middle portion of the cycle, the pawl encounters an extension on the carriage return function pawl and moves it down. Carriage return then occurs as described in 4.83 through 4.86.

Automatic Carriage Return-Line Feed (Sprocket Feed) (Figure 34)

4.112 Automatic carriage return-line feed in 3300 Series Coded Sets' sprocket feed typing units involves the action of the automatic codebar. The automatic codebar has projections on the right which can be removed to vary the line length and return the carriage on the 69th or 72nd character. The automatic codebar also has two slots on the underside, one associated with the automatic carriage return function lever and one towards the right associated with the automatic line feed function lever.

4.113 As the carriage approaches the right margin the carriage strikes the projection of the automatic codebar, moving it to the right. This allows both the automatic carriage return function lever and the automatic line feed function lever to move up.

4.114 As the automatic carriage return function lever moves up it engages its associated function pawl and carriage return proceeds as described in 4.84 thru 4.86. As the automatic line feed function lever moves up it engages its associated function pawl. As the automatic line feed function pawl moves downward it drives the

line feed strip pawl downward by means of the extension on the line feed strip pawl. An extension on the line feed lever controls the trip lever extension which pivots the clutch trip lever away from the shoe lever on the form feed clutch. The downward movement of the line feed strip pawl drives the line feed lever downward, tripping the form feed clutch. The clutch engages and the typing unit advances the form for single or double line feed. Near the end of the function cycle the line feed strip pawl strikes the projection of the line feed strip lever and moves towards the rear. Moving rearward the extension moves the automatic line feed function pawl to the rear which disengages it from its function lever.

S. Answer-Back Mechanism

4.115 The answer-back mechanism illustrated in Figures 36, 37, and 38 automatically transmits a predetermined sequence of characters for identification purposes.

4.116 A drum is coded with characters making up the answer-back sequence. When the answer-back mechanism is actuated, it rotates the drum, which sets up the code combinations in a set of answer-back contacts. The distributor converts the positions of the contacts to start-stop signals for transmission. After the answer-back sequence has been transmitted, the answer-back mechanism returns itself to its unoperated condition. For reasons that will be described, provisions are made for shunting the signal line during sensing of the first answer-back character of each cycle; and to prevent the answer-back from being actuated by the local generation of the answer-back call character.

4.117 The answer-back drum illustrated in Figure 35 has 11 levels as follows:

- (a) Five numbered levels
- (b) Feed ratchet
- (c) Stop cam
- (d) Character suppression
- (e) Three more numbered levels

4.118 Viewing it from the numbered end, the answer-back drum has 21 rows, ST (start) and 1 through 20. The feed ratchet serves to rotate the drum. The stop cam has tines

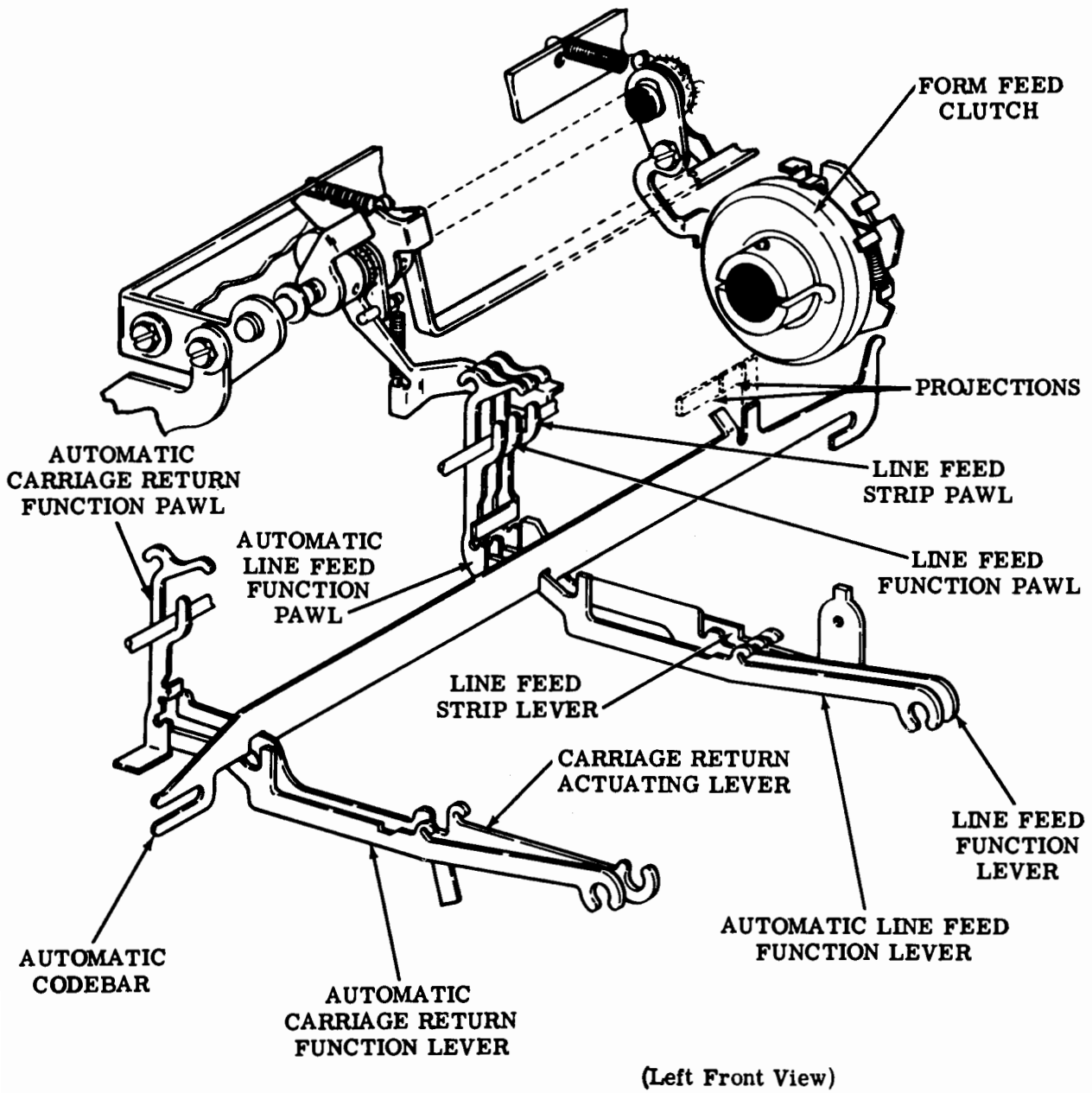

Figure 34 - Automatic Carriage Return-Line Feed Mechanism (Sprocket Feed)

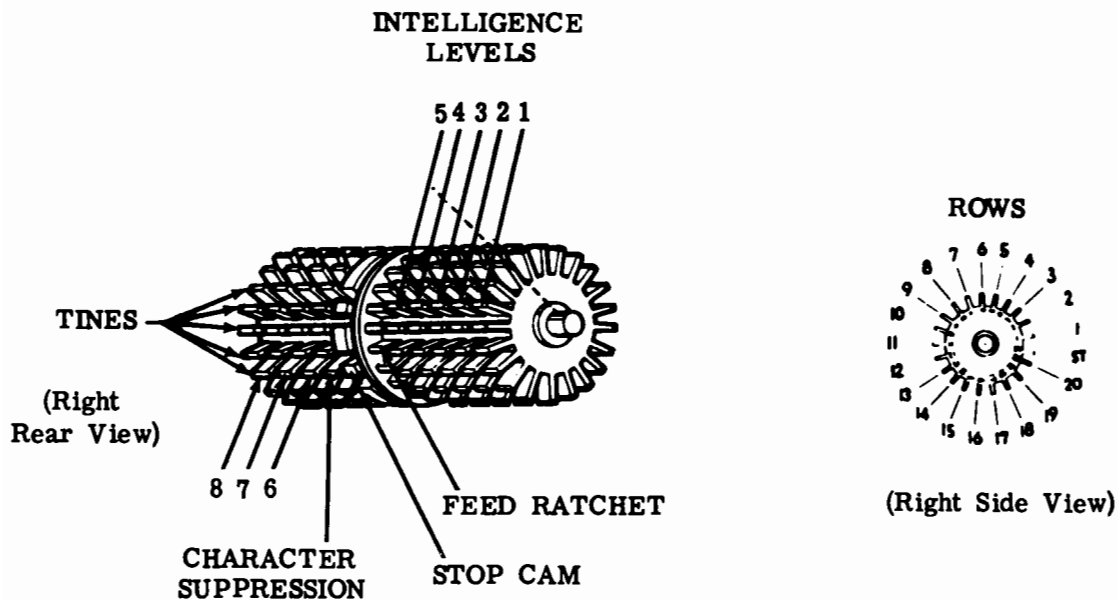

Figure 35 - Answer-Back Drum

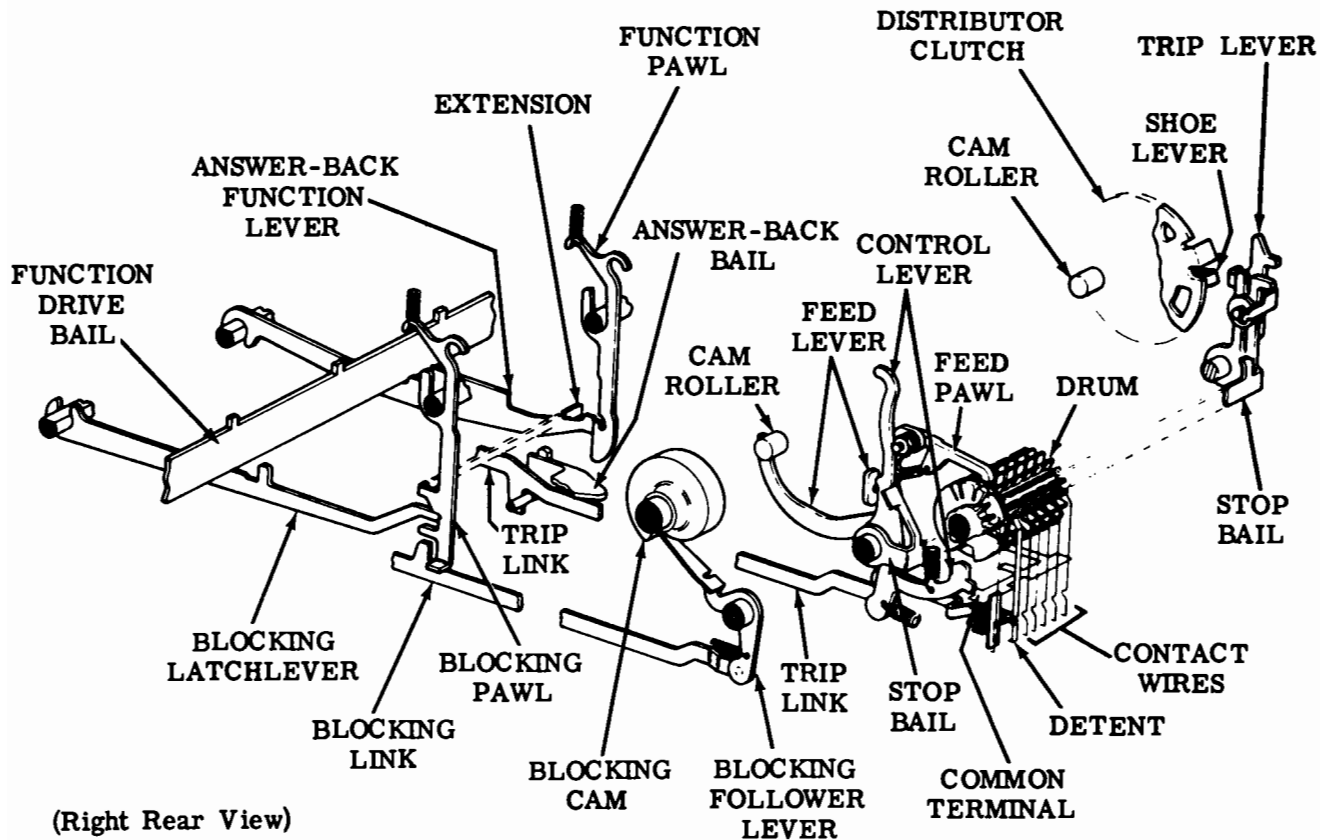

Figure 36 - Answer-Back Mechanism Remote Actuation

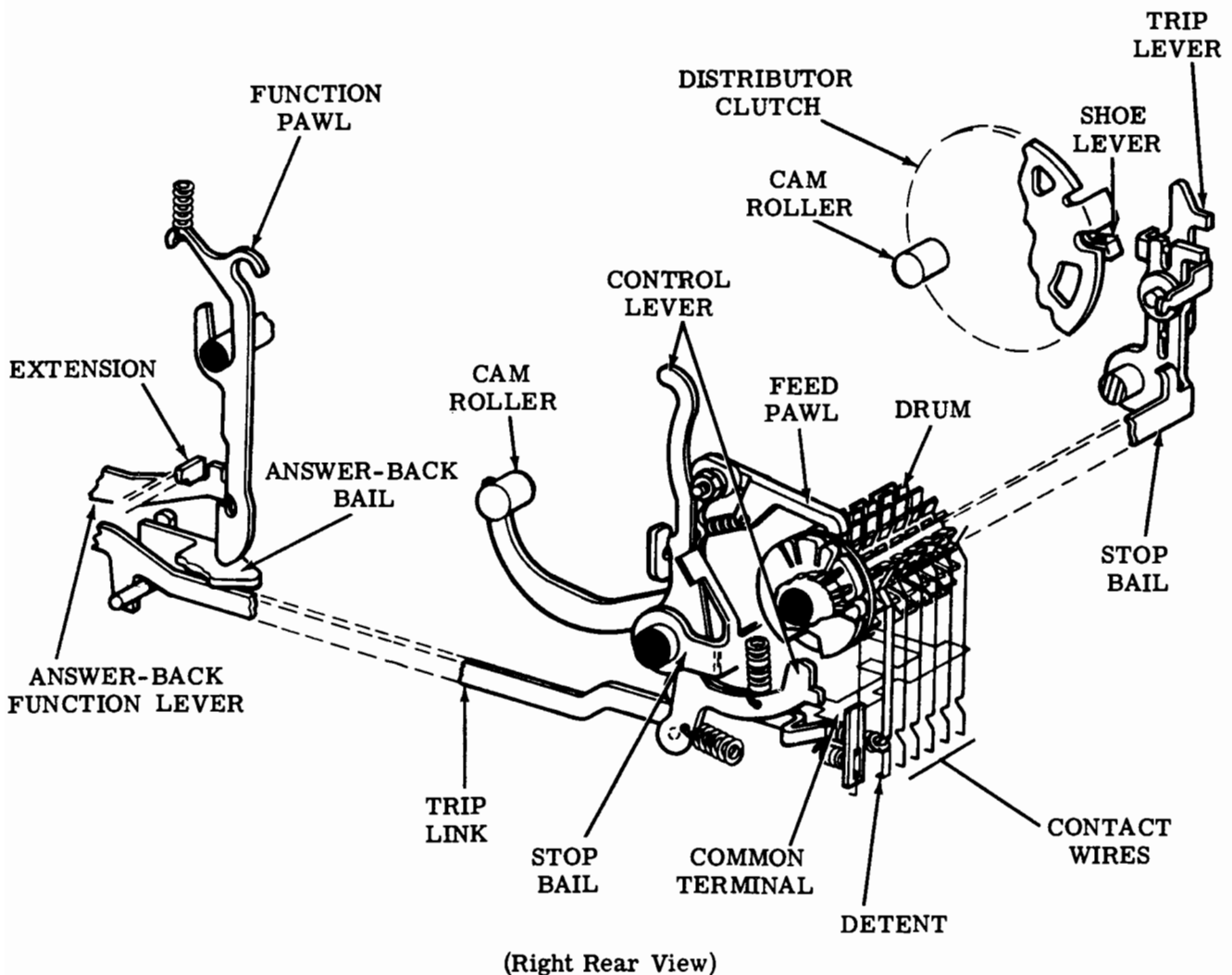

Figure 37 - Answer-Back Mechanism Local Actuation

which can be removed at various points so that the length of the answer-back message can be varied. The character suppression level is used to shunt the first answer-back character from the signal line. By breaking off tines in the various rows at the numbered intelligence levels, the drum may be coded to generate the proper answer-back characters. For example, if the first character of an answer-back message to be transmitted is the letter D code combination (--3---7-), tines at the no. 3 and no. 7 levels should be broken off in the appropriate row where the answer-back message is to start. The second character of the message would be coded into the next succeeding row.

Note 1: All answer-back messages should be preceded by the "carriage return," and "line feed" code combinations.

Note 2: For details on answer-back drum coding refer to the adjustment Section 574-122-700TC.

- 4.119 The answer-back mechanism can be actuated in three ways.
- (a) Remotely, by the reception of a pre-determined call character.
 - (b) Locally, by depressing the HERE IS key.

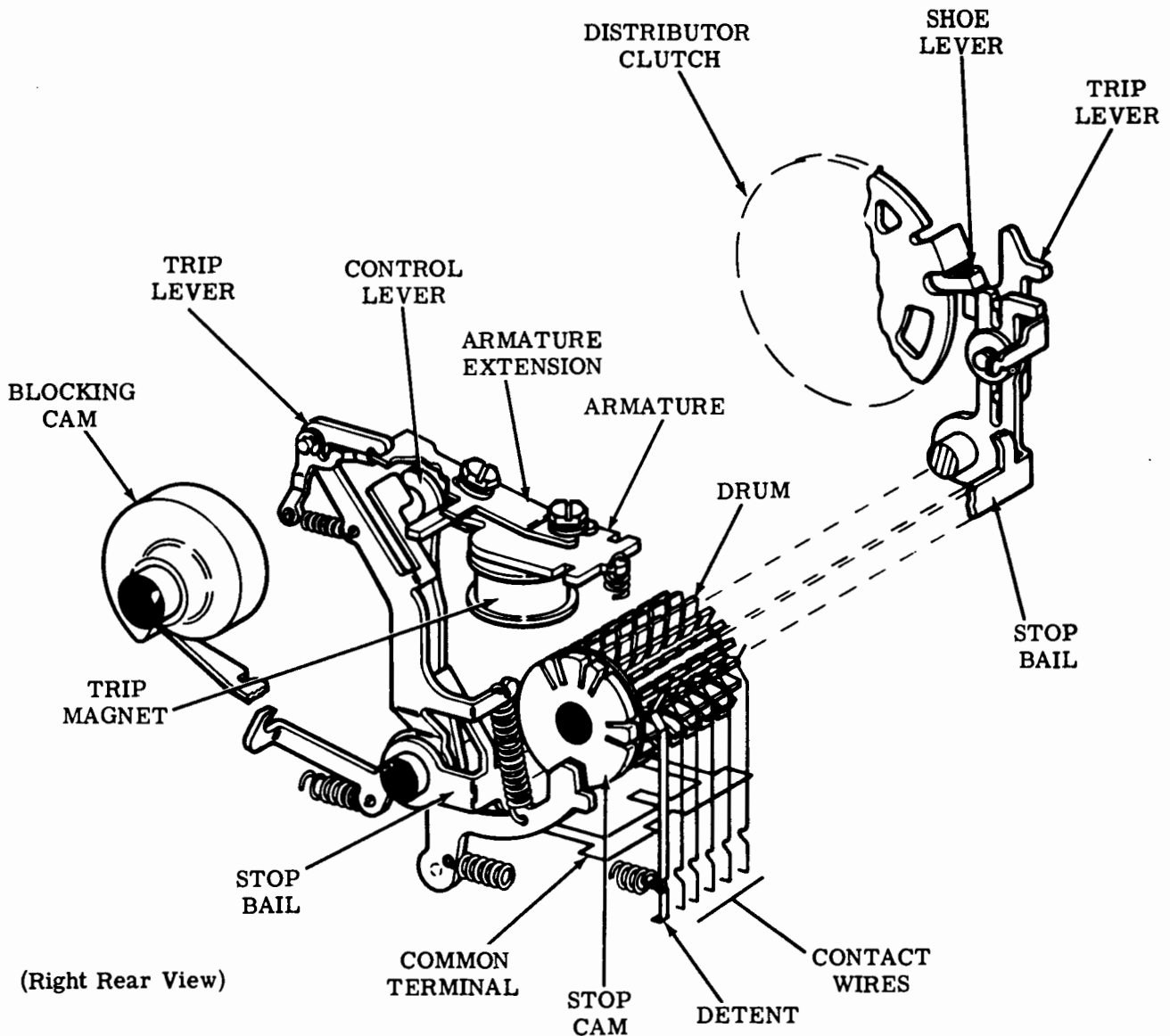

Figure 38 - Answer-Back Mechanism Automatic Actuation

(c) Automatically, by actuating the answer-back trip magnet mechanism from some external equipment, such as a data set.

4.120 Remote Actuation (Figure 36): When the answer-back call character is received by the typing unit, the answer-back function lever moves up to engage its function pawl. As the function lever and pawl are moved down by the function bail, the pawl pivots the answer-back bail. In pivoting, the answer-back bail moves a trip link frontward. The trip link pivots the control lever out of the indentation on

the stop cam. The control lever, through the stop bail, moves the trip lever rearward, out of engagement with the shoe lever, allowing the distributor clutch to engage.

4.121 When the distributor clutch begins to rotate, a cam roller moves up and permits the feed lever to pivot rearward against the control lever. The feed pawl attached to the feed lever moves rearward to engage the next tooth on the drum ratchet. Near the end of the function cycle the function pawl is stripped from its function lever by the stripper bail. The

control lever, under spring tension, tends to return to its unoperated position in the indentation of the stop cam. This would terminate the answer-back operation by disengaging the distributor clutch. However, since the feed pawl is engaged with the next tooth on the ratchet, the spring tension on the control lever is not enough to overcome the combined tension of the feed lever spring and the drum detent. Thus the mechanism remains in its operated condition throughout the distributor cycle.

4.122 Near the end of the distributor cycle, the cam roller on the distributor clutch moves the feed lever and feed pawl frontward, and the pawl acts on the ratchet to rotate the drum one tooth. The stop cam on the drum now prevents the control lever and trip lever from returning to their stop position. The distributor clutch thus continues to cycle and rotates the answer-back drum.

4.123 The answer-back contacts are wired in parallel with the keyboard contacts to the segments of the distributor disc. As the drum rotates during the answer-back operation, the contact wires, under spring tension, sense each row of tines. If a tine has been broken off at a given level in a row, the associated wire moves frontward to its marking position against a common terminal. On the other hand, if a tine is present, it holds the wire away from the terminal in its spacing position. As the distributor clutch cycles, the distributor converts the positions of the contacts to sequential start-stop signals for transmission.

4.124 The drum continues to rotate until the next indentation in the stop cam is presented to the control lever. The latter then moves into the indentation and returns the associated parts to their unoperated position. The shoe lever then strikes the trip lever and disengages the distributor clutch. The mechanism is thus returned to its unoperated condition.

4.125 Local Actuation: When the HERE IS keytop is depressed on the keyboard, it pivots a bellcrank which moves the trip link frontward. The trip link pivots the control lever to its operated position and the answer-back proceeds as described in remote actuation (4.120).

4.126 Automatic Actuation: The answer-back mechanism of a distant station may be actuated by completing a connection through the

local data set or some other equipment. The trip magnet on the distant station is energized. Being energized it attracts the trip magnet armature which allows the trip lever to move frontward. A tab on the trip lever pivots the control lever out of the indent of the stop cam allowing the clutch to engage. As the clutch rotates the blocking cam also rotates. A blocking follower rides the blocking cam and rotates clockwise. By means of a tab the blocking follower rotates the trip lever which latches against the de-energized armature extension. It remains in this position until the magnet is again energized.

4.127 Since the answer-back, keyboard, and tape reader (where used) contacts are wired in parallel with the distributor disc, the answer-back contacts must all be in their spacing position when the mechanism is unoperated, so that they do not interfere with keyboard or tape reader transmission. Therefore, because the answer-back feed mechanism does not feed the drum until near the end of the first cycle, the first character sensed should be all spacing to prevent garbling of the regular message sent from the keyboard and/or tape reader. However, an all "spacing" character is undesirable in some systems. Therefore, a way is provided for shunting transmission from the signal line during the sensing of the first answer-back character.

4.128 As mentioned, the trip link moves frontward when the answer-back sequence is initiated and remains there until it is terminated. In this position it permits a character suppression contact wire to sense the drum character suppression level. The character suppression contact is wired so that it shunts transmission from the outgoing signal line when it is closed. The tine at the character suppression level of the first character of each answer-back cycle must always be broken off in order to accomplish this. Thus the character suppression contact wire is selected and keeps the line marking until the second character is sensed. The tines are left in the character suppression level in other rows, except for certain conditions, such as to correct coding errors and to vary the message length. This allows, in effect, one character delay before the message coded into the answer-back drum is transmitted. At the end of the operation, the trip link again moves rearward and holds the contact wire unselected while the mechanism is unoperated.

4.129 Answer-back Suppression on Transmission: Since the typing unit receives every code combination that it transmits, the sending of the answer-back call character would actuate the local answer-back as well as the one at the distant station. To prevent this, a blocking mechanism prevents the function mechanism from operating in the answer-back area during transmission.

4.130 As the distributor clutch rotates, the blocking cam pivots the blocking follower lever which pulls a blocking link rearward. The link pivots the blocking pawl rearward until it releases a blocking latchlever which, under spring tension, moves up against the function drive bail. When the function drive bail and the blocking latchlever move up during the function cycle, the blocking latchlever cams the blocking pawl further rearward where an extension on the pawl is over an extension on the answer-back function lever. The function lever is thus prevented from moving up far enough to be latched by its pawl and initiate the answer-back sequence.

4.131 During the latter part of the distributor cycle, the blocking cam allows the blocking link to move frontward to its unoperated position. As the function drive bail moves down during the middle portion of the function cycle, it drives the blocking latchlever downward to the point where the blocking pawl is permitted to pivot frontward to its unoperated position. Thus every time a character is initiated locally, the distributor clutch cycles and operates the blocking mechanism which prevents the answer-back function lever from sensing the codebars and initiating the answer-back sequence regardless of what character is processed by the typing unit. On the other hand, when remotely initiated characters are received, the distributor clutch does not cycle, the blocking mechanism is not operated, and the function lever is permitted to sense the codebars and initiate the answer-back sequence upon receipt of the predetermined call-character signal.

4.132 The length of the answer-back sequence can be varied either by altering the stop-cam level or the character-suppression level.

(a) Stop Cam: The answer-back mechanism can be coded for either 1-, 2-, or 3-cycle operation by removing the appropriate tine(s) from the stop-cam level. In 1-cycle operation, the stop cam in row "6" is removed.

This coding yields a maximum of 20 rows which are available for coding different characters into the answer-back drum. There are actually 21 rows on the answer-back drum, but only 20 rows can be used for coding since one row is suppressed. The number of rows available for message coding is summarized below for 1-, 2-, or 3-cycle operation:

Cycle Operation	Actual Rows	Available Rows
1	21	20
2	10(11)*	9(10)*
3	7	6

* Alternately, one then the other.

When multiple-cycle operation is employed, the answer-back sequence must be coded in each segment of the answer-back drum so that the same message will be transmitted each time the answer-back mechanism is initiated.

(b) Character Suppression: Quite often, due to message length, messages coded into the answer-back drum do not require the use of every available row for coding. Unneeded rows are eliminated from the message transmission by removing the unneeded character suppression tine(s). The answer-back drum will stop through its complete cycle, but the transmission of the coded characters from the unneeded rows will be shunted from the signal line.

Note: The character-suppression tine in the last row of a cycle should not be removed on 33 typing units used in systems where a response to each answer-back actuation signal must always be obtained. If the tine is removed, the answer-back mechanism will not respond to consecutive answer-back actuation signals. This is due to the operating characteristics of the typing unit which, when the character-suppression tine in the last row of a cycle is removed, leaves the answer-back blocking panel blocking at the end of the answer-back drum cycle of operation. The answer-back blocking pawl will remain blocking until after another character is received through the selector mechanism. The subsequently received character causes the function mechanism to reset the answer-back blocking pawl to its unblocking position. After being reset and

upon receipt of an answer-back actuation signal, the answer-back mechanism will be triggered. Hence, with the character-suppression time removed from the last row of an answer-back cycle, typing unit answer-back mechanisms will only respond to every other answer-back actuation signal unless an intervening character is received through the selector mechanism.

5. OPTIONAL FEATURES

PRINT NONPRINT

5.01 The function of the print nonprint mechanism is to block all the function levers from rising (except the print suppression function lever) during the function cycle. There are

two types of print nonprint mechanisms, one magnet operated and one solenoid operated.

A. Magnet Operated

5.02 The magnet operated print nonprint mechanism shown in Figure 39 allows transmission or reception of tape messages without printed page copy. An on and off toggle switch and a red indicator lamp mount to the right of the platen on the call control unit panel. The switch controls a magnet attached to the typing unit casting. The red indicator lamp lights when the mechanism is activated and the typing unit placed in the nonprint mode. Operation of the magnet attracts an armature which pivots a bellcrank. Operation of the bellcrank moves a nonprint codebar which blocks all the function levers except a special function lever. This special function lever rises every cycle. In so doing, it blocks the print suppression

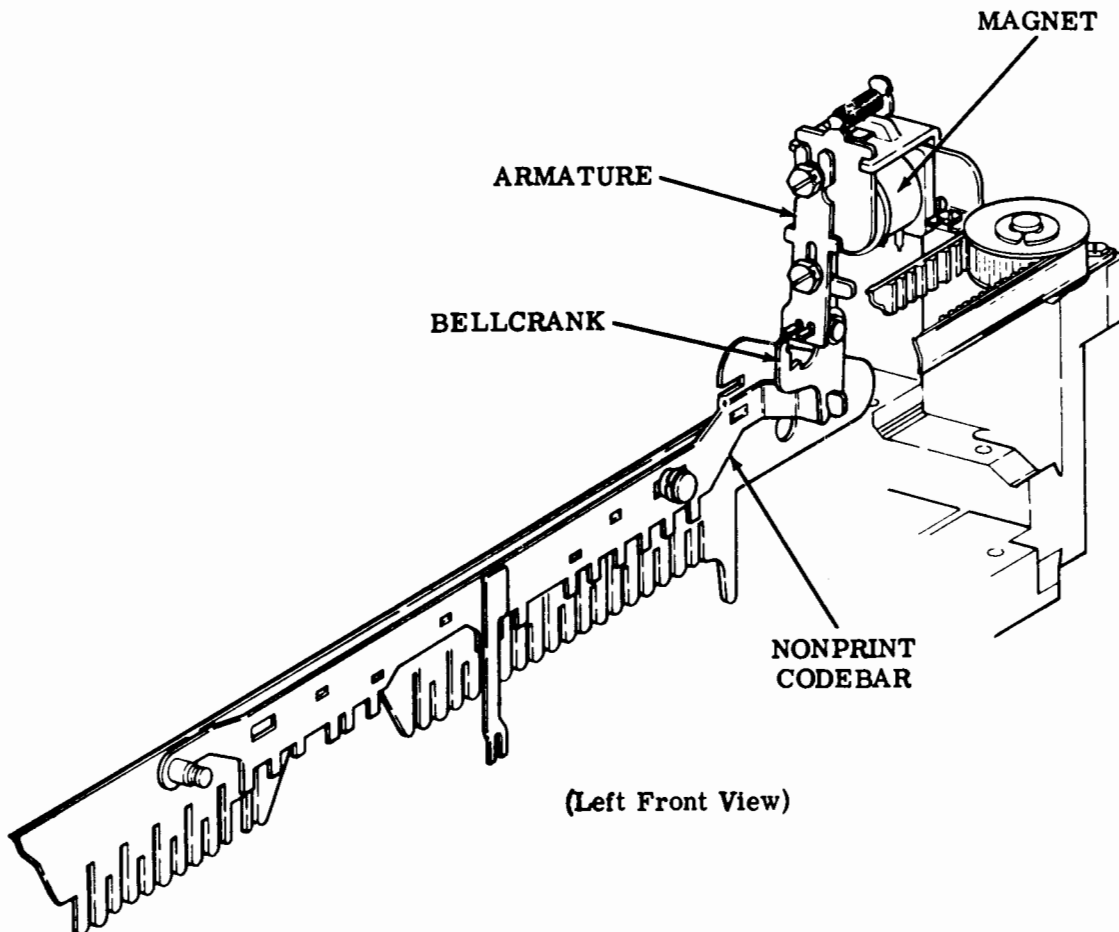

Figure 39 - Magnet Operated Print Nonprint Mechanism

codebar and thus printing is suppressed. Turning the mechanism off extinguishes the indicator light and the nonprint codebar returns to its unoperated position under spring tension.

B. Solenoid Operated

5.03 The solenoid operated print nonprint mechanism shown in Figure 40 is a remote-controlled device consisting of a bracket

which supports a solenoid. At the end of the solenoid plunger is attached a lever which is part of the nonprint codebar. Activation of the solenoid pulls the plunger and thus positions the nonprint codebar, blocking all the function levers except the print suppression function lever. Operation of the print suppression function lever suppresses printing. At the receipt of the off signal the nonprint codebar moves to its unoperated position under spring tension.

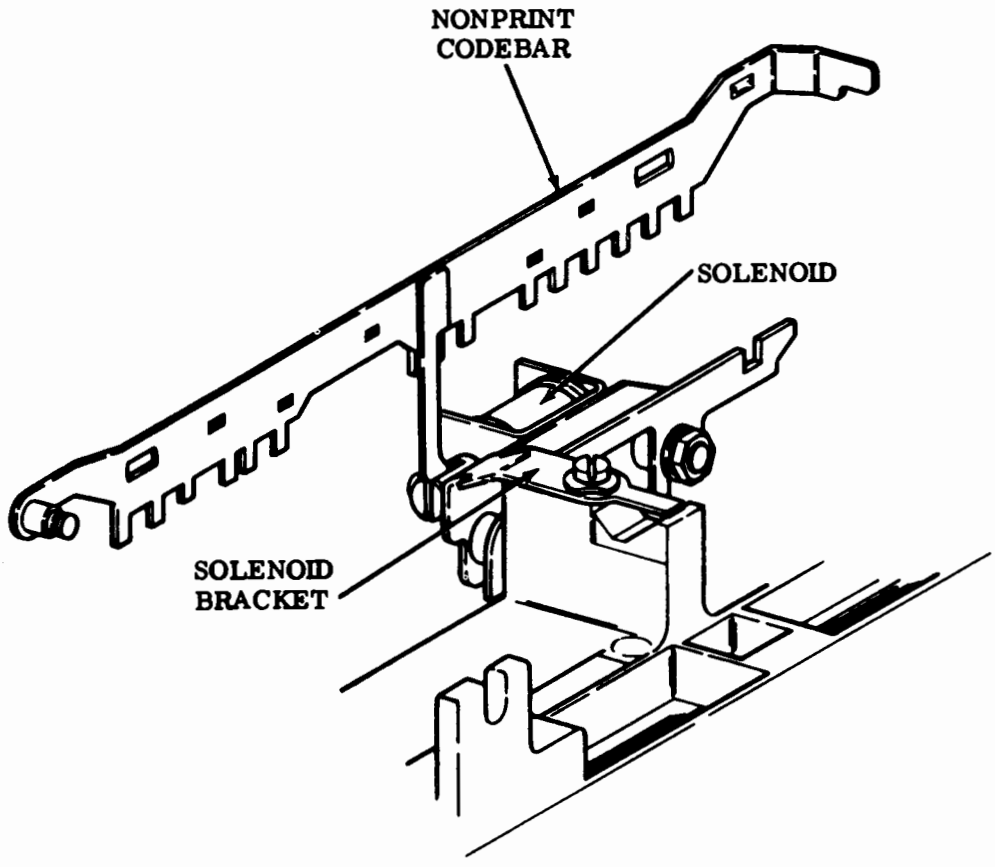

(Left Front View)

Figure 40 - Solenoid Operated Print Nonprint Mechanism

33 TYPING UNIT
 LUBRICATION



CONTENTS	PAGE	CONTENTS	PAGE
1. GENERAL	1	Trip lever	9
2. BASIC UNITS	3	Trip shaft	4
COMMON MECHANISMS	3	Typewheel mechanism	17
Armature	19	FRICITION FEED	
Automatic codebar	10	MECHANISMS	21
Blocking levers	19	Line feed mechanism	22
Carriage area	14	Paper feed area	21
Carriage rear rail	18	Platen	21
Carriage return and spacing levers	13	SPROCKET FEED	
Codebars	10	MECHANISMS	22
Codebar clutch	5	Cam, pulley, and gear	
Dashpot	15	combination	24
Disc and brushes	8	Form-out mechanism	25
Distributor area	7	Line feed clutch	26
Drive arm	16	Paper feed area	22
Drive mechanism	12	Platen mechanism	23
Function area	9	Platen drive area	24
Function clutch	4	3. VARIATIONS TO BASIC	
Function levers	10	UNITS	26
Function rocker shaft	7	Answer-back area	26
Function shaft area	6	Answer-back mechanism	27
Intermediate gears	6	Trip magnet	27
Latchlever	8	Print nonprint mechanism	28
Latchlever and trip lever	20	1. GENERAL	
Main shaft area	4	1.01 This section provides lubrication	
Motor area	5	instructions for the 33 typing unit. It is	
Print hammer	16	reissued to add new lubrication interval require- ments for the typing unit. Marginal arrows indi- cate changes and additions.	
Pushlevers and stripper bail	19	1.02 The general lubrication areas are illus- trated by photographs. The specific points to receive lubricant are indicated on line drawings with appropriate textual instructions. Line drawings and textual instructions follow each photograph and are keyed to the photograph by paragraph numbers.	
Reset arm	16		
Reset bail	11		
Ribbon guide spring	18		
Ribbon mechanism	17		
Rocker and pawls	11		
Selector area	18		
Selector clutch	20		
Selector levers	20		
Slides	15		
Slide guideplates	15		
Spacing area	12		
Space bellcrank	12		
Spacing mechanism — 1	13		
Spacing mechanism — 2	14		
Stop bail	8		
Stripper drive lever	10		

1.03 Thoroughly lubricate the typing unit, but avoid overlubrication that might permit the lubricant to drip or be thrown onto adjacent parts. Saturate all felt washers and oilers with oil, and apply oil to each end of all bearings.

1.04 Initial lubrication of the typing unit should be completed just prior to placing it into service. The lubrication intervals for the tape punch are similar to the lubrication intervals of the set. The lubrication intervals are dictated by the hours of use (including idle time) on a daily basis. The following charts and notes list the appropriate lubrication intervals.

LUBRICATION INTERVALS IN WEEKS
BASED ON 5-DAY WEEK (Note 1)

NEWLY INSTALLED EQUIPMENT			
SPEED	DAILY USE		
	0 TO 8 HOURS	8 TO 16 HOURS	16 TO 24 HOURS
All Speeds	3 Weeks	2 Weeks	1 Week

REGULAR LUBRICATION			
SPEED	DAILY USE		
	0 TO 8 HOURS	8 TO 16 HOURS	16 TO 24 HOURS
60 WPM	39 Weeks	26 Weeks	13 Weeks
100 WPM	26 Weeks	13 Weeks	6 Weeks

Note 1: Reduce lubrication interval 15 percent when usage is 6 days per week, and 30 percent when usage is 7 days per week.

Note 2: Sets operating at speeds between 60 and 100 wpm use lubrication requirements for the lower of the two speeds.

Note 3: The lubrication intervals are for the set as a whole — all components of the set should be lubricated.

Note 4: Just prior to storage all equipment should be thoroughly lubricated.

Note 5: Model 33 typing units having Serial Numbers 144,000 and above use the lubrication interval described in 1.04. Model 33 typing units having Serial Numbers below 144,000 should reduce the lubrication interval by 1/3 or 33 percent.

1.05 On occasion when the printer is disassembled, apply a coat of thoroughly mixed 50 percent KS7470 oil and 50 percent KS7471 grease at places indicated below.

- Selector Cam Surfaces (2.44)
- Spacing Gear Teeth (2.23)
- Codebar Pivot Shaft (2.17 and 2.18)
- Eccentric Cams (2.02 and 2.04)
- Stop Bail Adjusting Tab (2.11)
- Platen Shaft Bearings — Sprocket Feed Units only (2.49)
- Distributor Shaft Cam Roller (Early Design) or Stud (Late Design) (2.13)
- H-Lever (2.13)

Note 1: On occasion when the clutch is disassembled, lubricate the Internal Clutch Assemblies (2.02, 2.04, 2.44, and 2.53 on Form Feed Mechanisms only) as follows: Apply a thin coat of KS7471 grease at the loops of the clutch shoe lever spring, and lubricate the internal mechanism of the clutch with KS7470 oil.

Note 2: At regular lubrication intervals lubricate the clutch mechanism with KS7470 oil only.

1.06 The textual instructions that accompany the line drawings consist of abbreviated directions, specific lubrication points, and parts affected. The meanings of the abbreviated directions (symbols) follow:

<u>Symbol</u>	<u>Meaning</u>
D	Keep dry — no lubricant permitted.
G	Apply thin coat of grease (KS7471).
O	Oil (KS7470).

1.07 References to left, right, front, or rear, etc, consider the typing unit to be viewed from a position where the carriage area faces up and the selector area is located to the viewer's left.

CAUTION: DO NOT USE ALCOHOL, MINERAL SPIRITS, OR OTHER SOLVENTS TO CLEAN PLASTIC PARTS OR PARTS WITH PROTECTIVE-DECORATIVE FINISHES. NORMALLY, A SOFT, DRY CLOTH SHOULD BE USED TO REMOVE DUST, OIL, GREASE, OR OTHERWISE CLEAN PARTS OR SUBASSEMBLIES. IF NECESSARY, A SOFT CLOTH DAMPENED WITH SOAP OR MILD DETERGENT MAY BE USED.

AFTERWARDS, RINSE EACH CLEANED PART OR SUBASSEMBLY WITH SOFT, DAMP CLOTH AND BUFF WITH A SOFT, DRY CLOTH.

1.08 Tools and materials needed for teletypewriter lubrication are listed in Section 570-005-800TC.

1.09 For disassembly and reassembly information, refer to Section 574-122-702TC.

CAUTION: ALL ELECTRICAL POWER MUST BE REMOVED FROM UNIT BEFORE LUBRICATING OR REMOVING COMPONENTS FOR LUBRICATION.

2. BASIC UNITS

COMMON MECHANISMS

2.01 Main Shaft Area

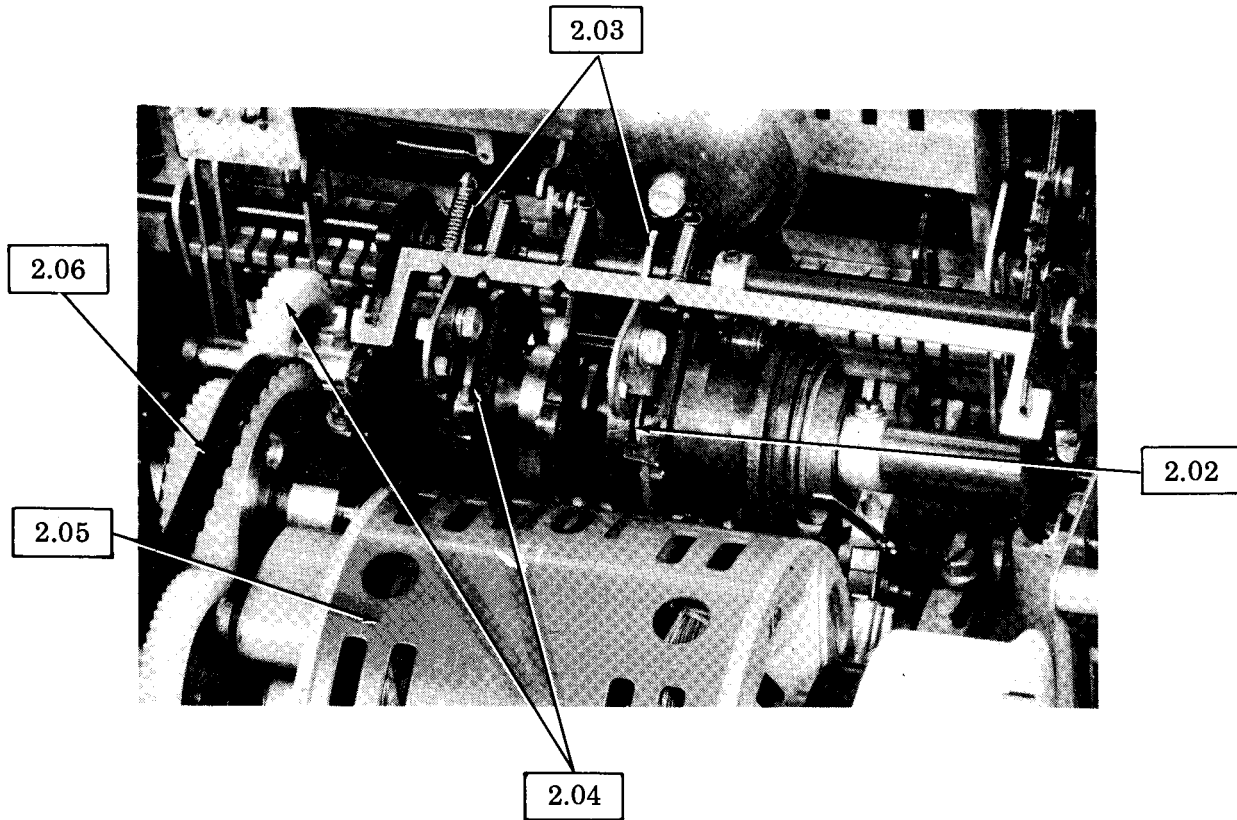

SECTION 574-122-701TC

2.02 Function Clutch

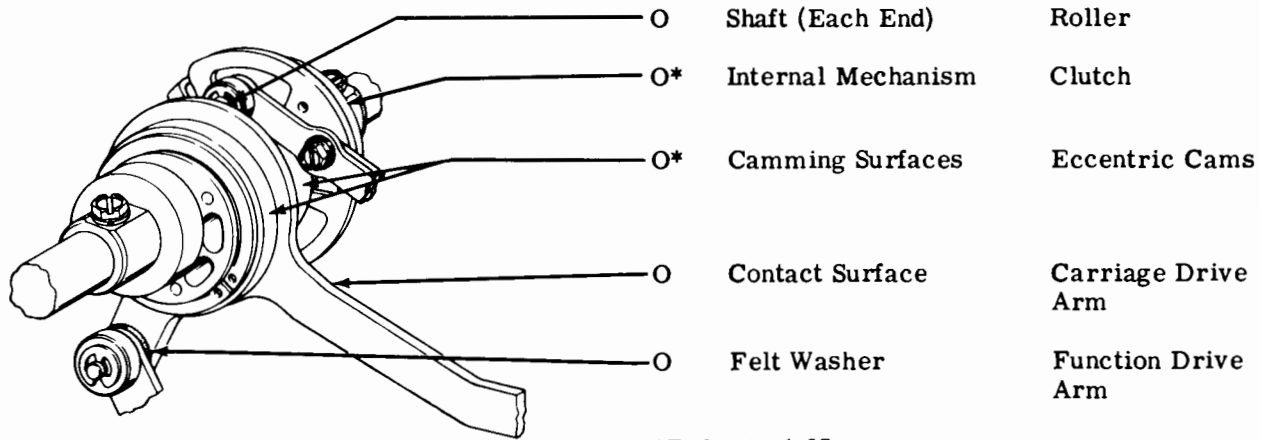

*Refer to 1.05.

(Left Front View)

2.03 Trip Shaft

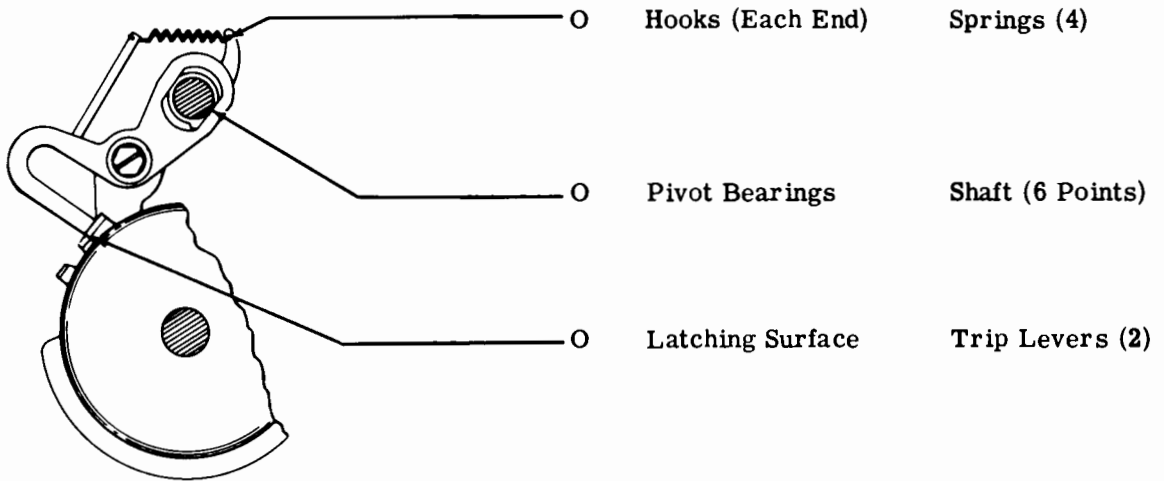

(Left Side View)

2.04 Codebar Clutch

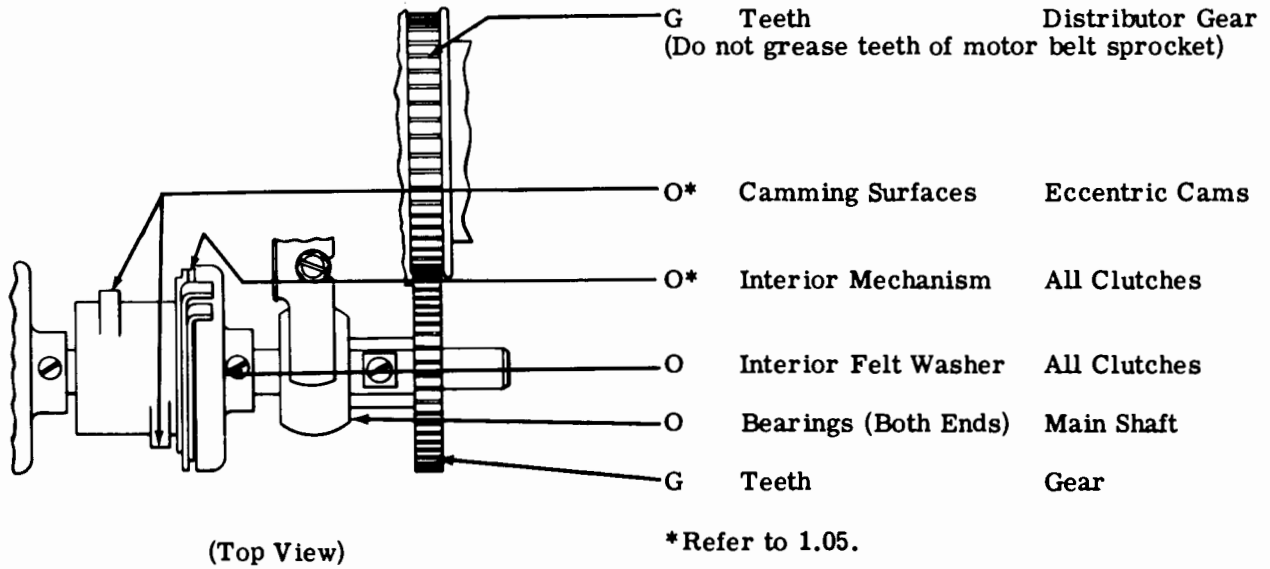

2.05 Motor Area

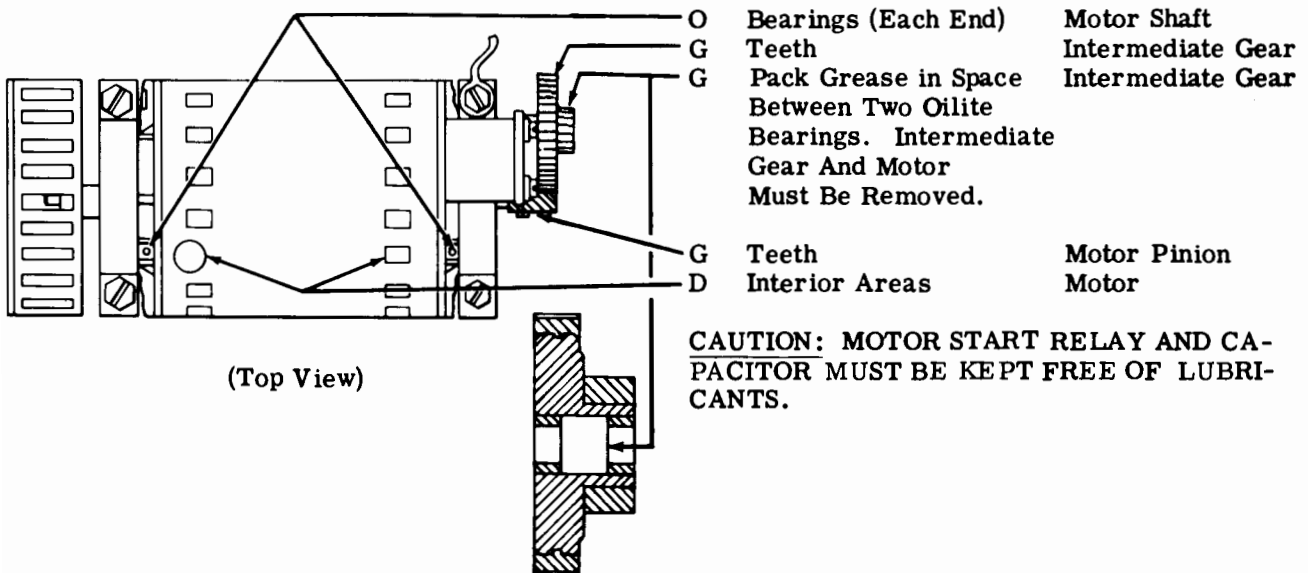

2.06 Intermediate Gears

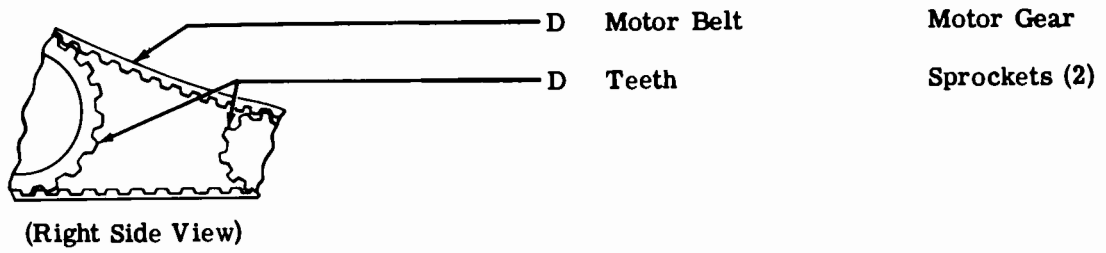

2.07 Function Shaft Area

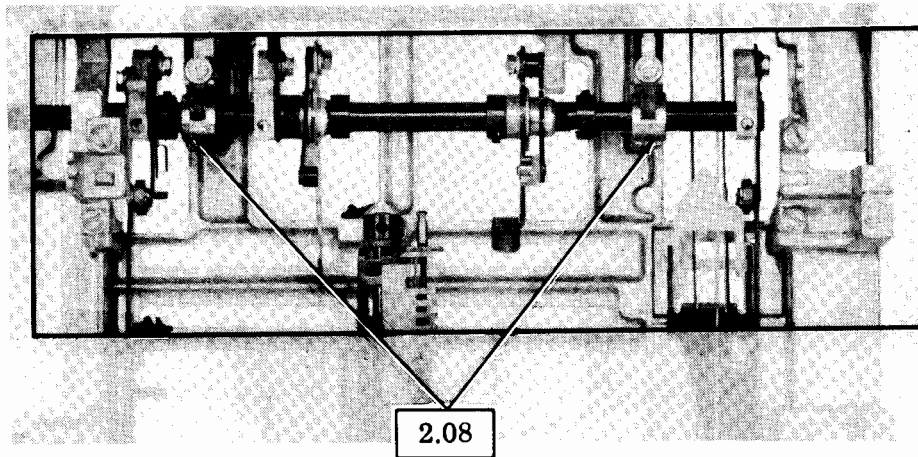

(Top View)

(Typing unit disassembled for illustration only.)

2.08 Function Rocker Shaft

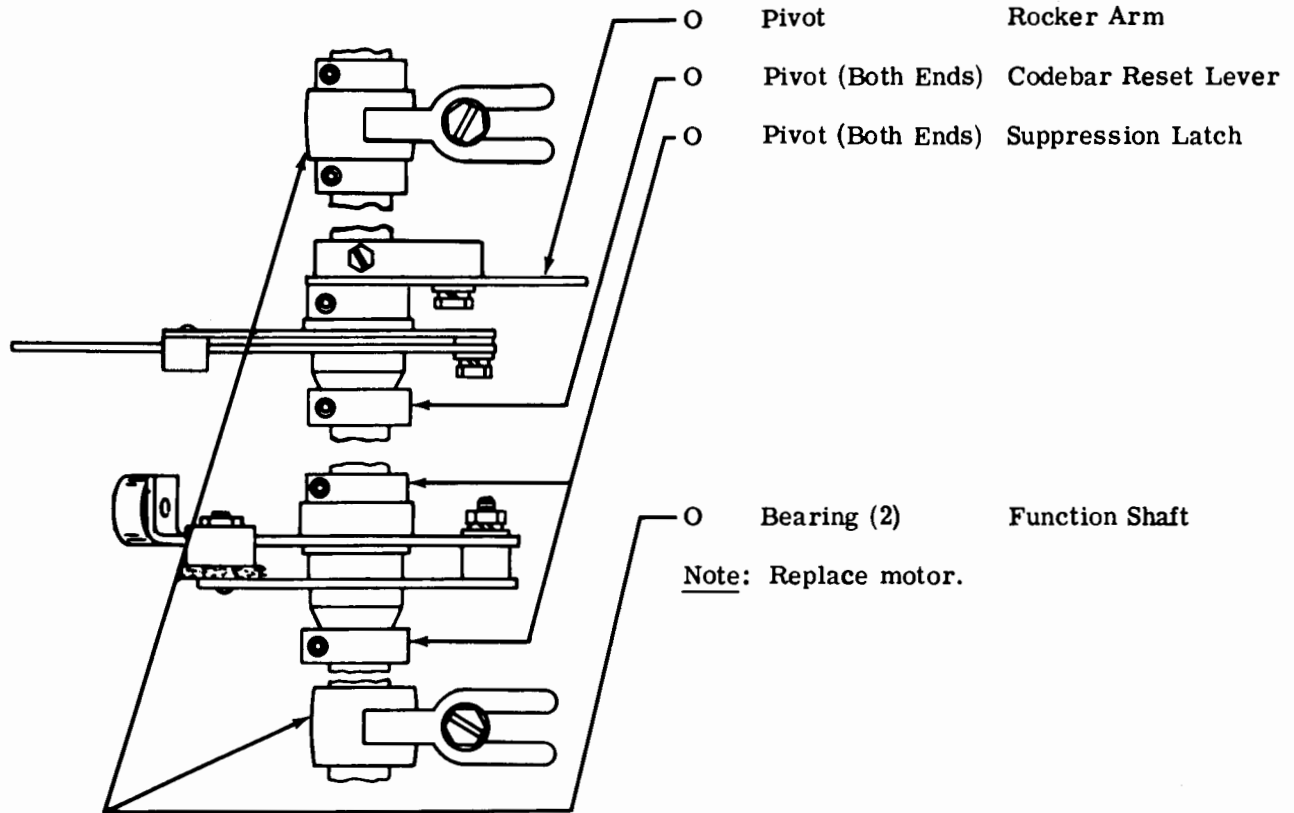

2.09 Distributor Area

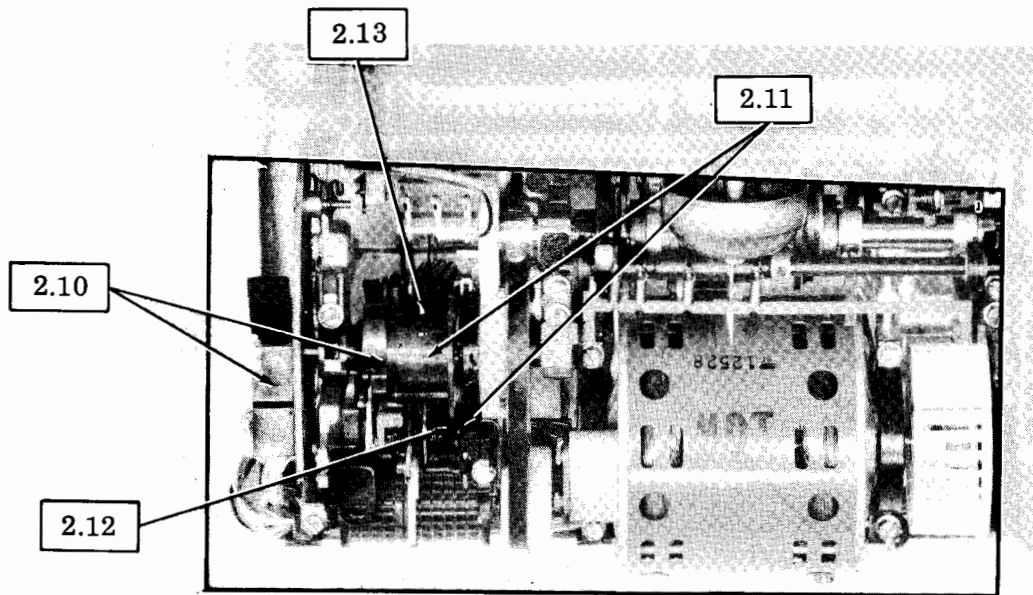

(Top View)

2.10 Disc and Brushes

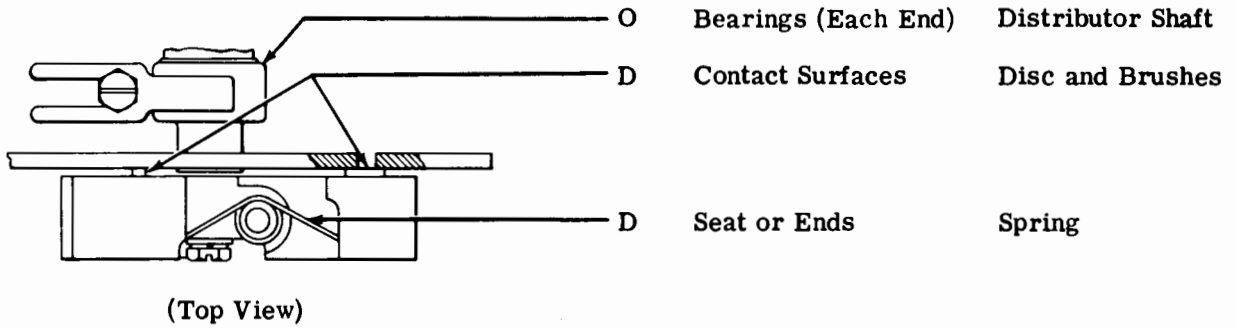

2.11 Stop Bail

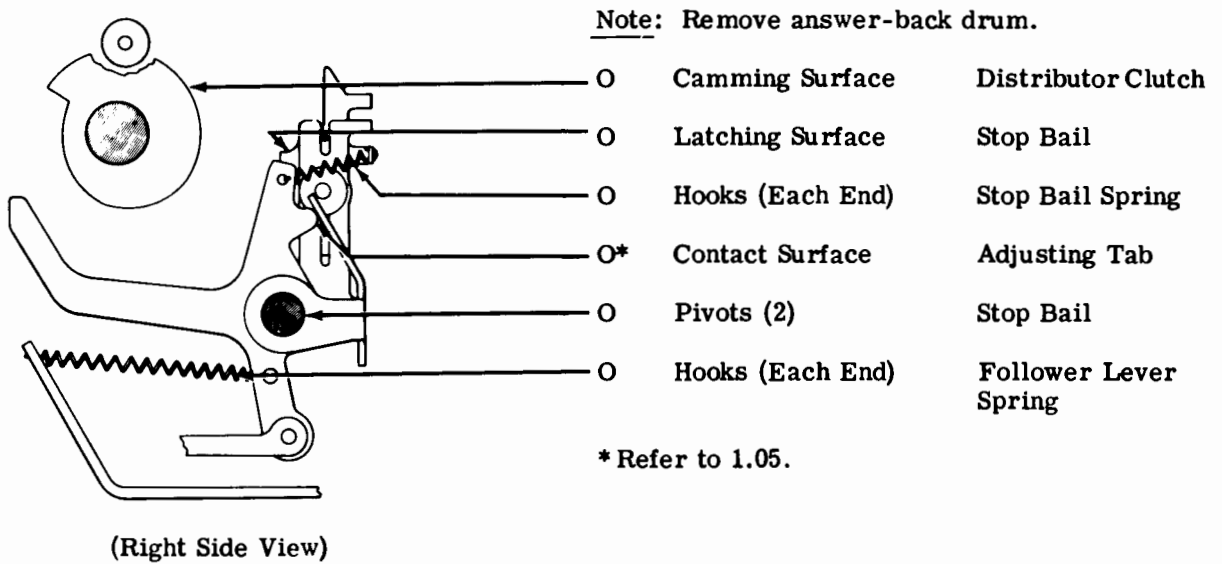

2.12 Latchlever

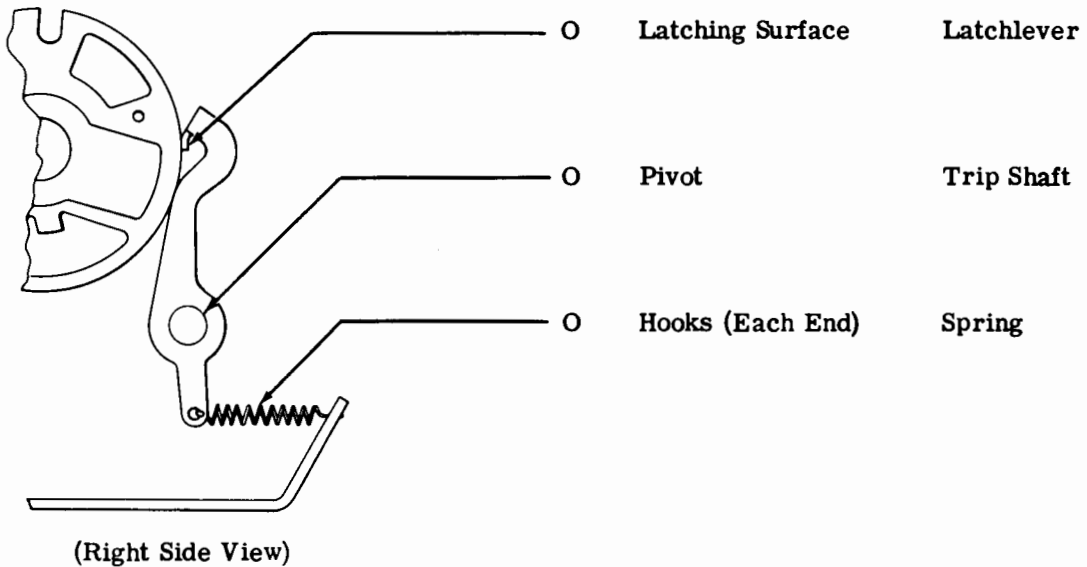

2.13 Trip Lever

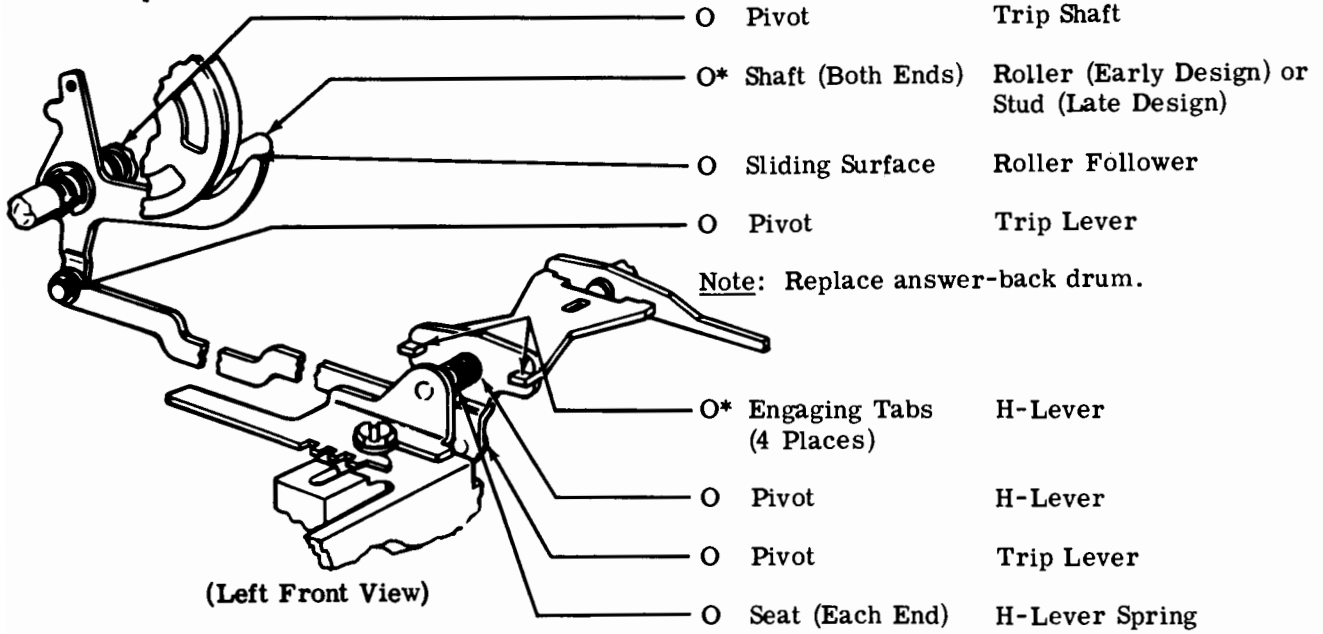

*Refer to 1.05.

2.14 Function Area

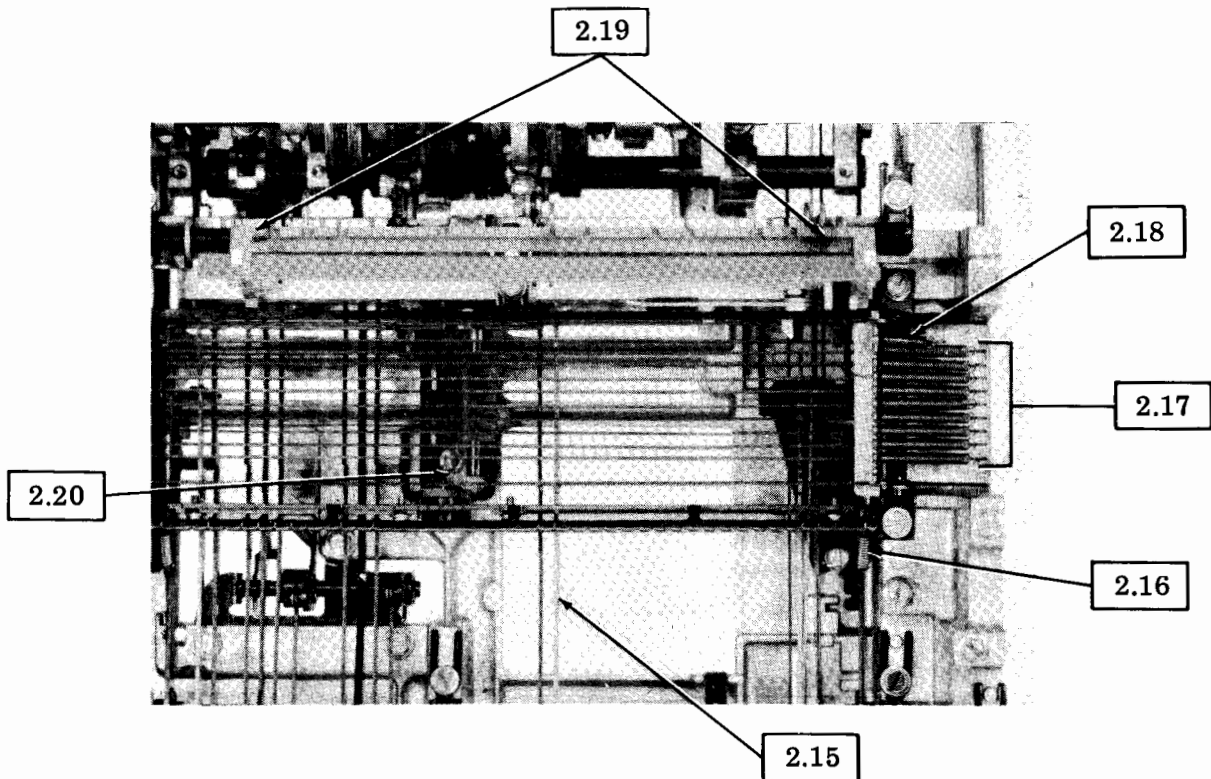

2.15 Function Levers

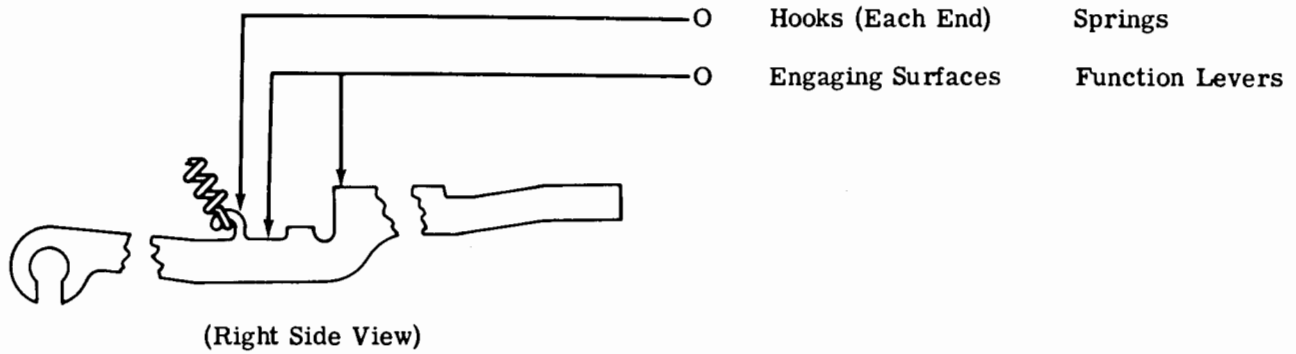

2.16 Stripper Drive Lever

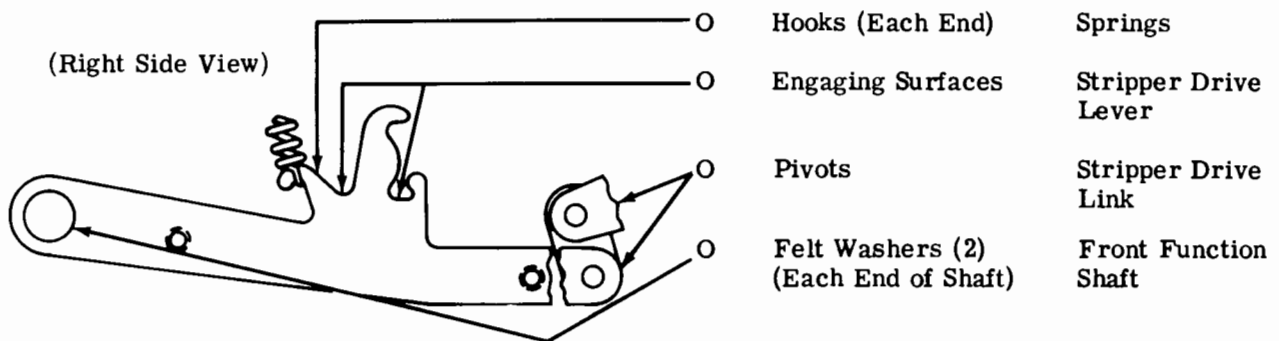

2.17 Codebars

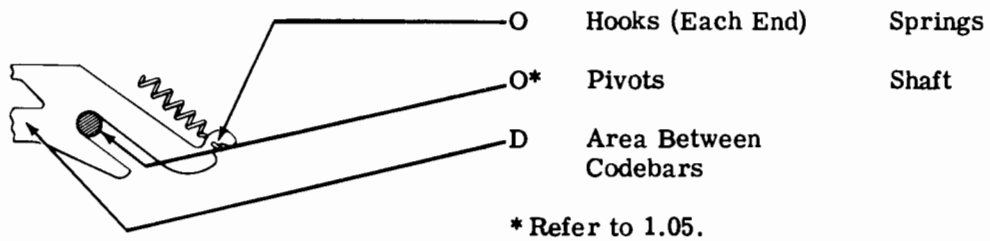

2.18 Automatic Codebar

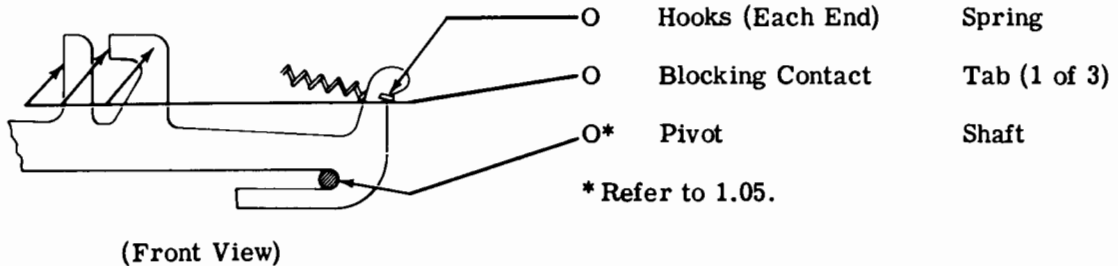

2.19 Rocker and Pawls

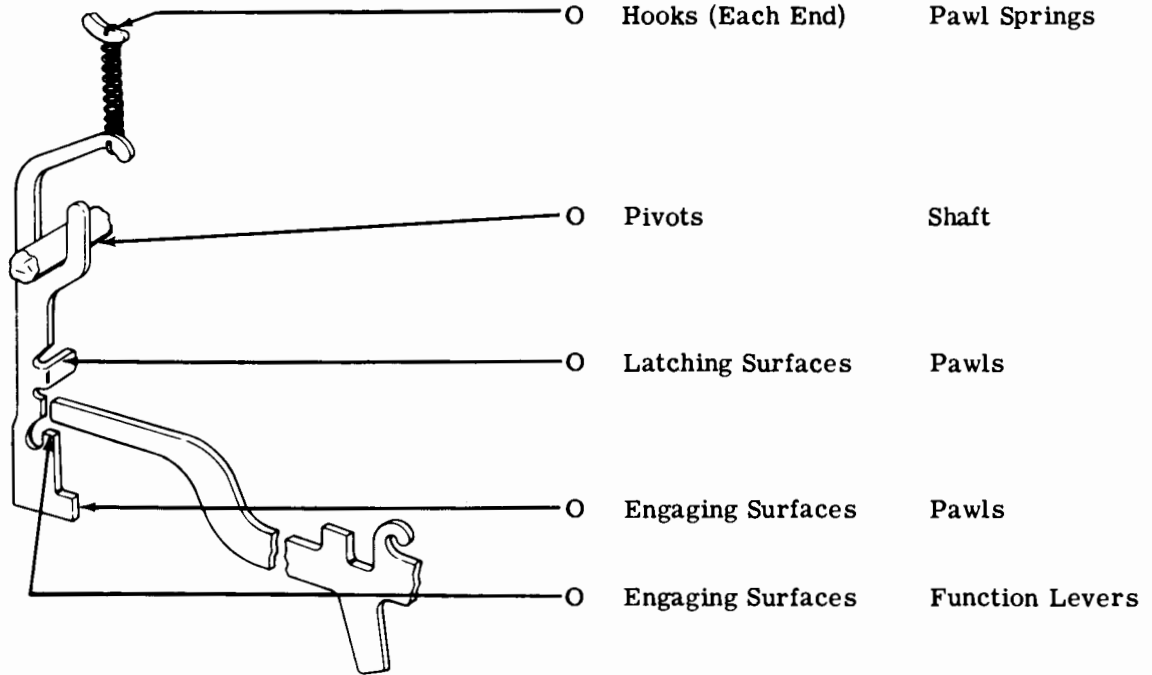

(Left Front View)

2.20 Reset Bail

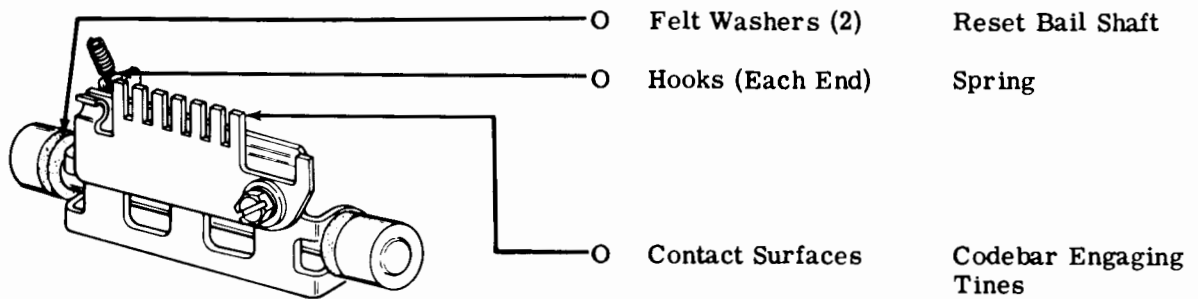

(Left Front View)

2.21 Spacing Area

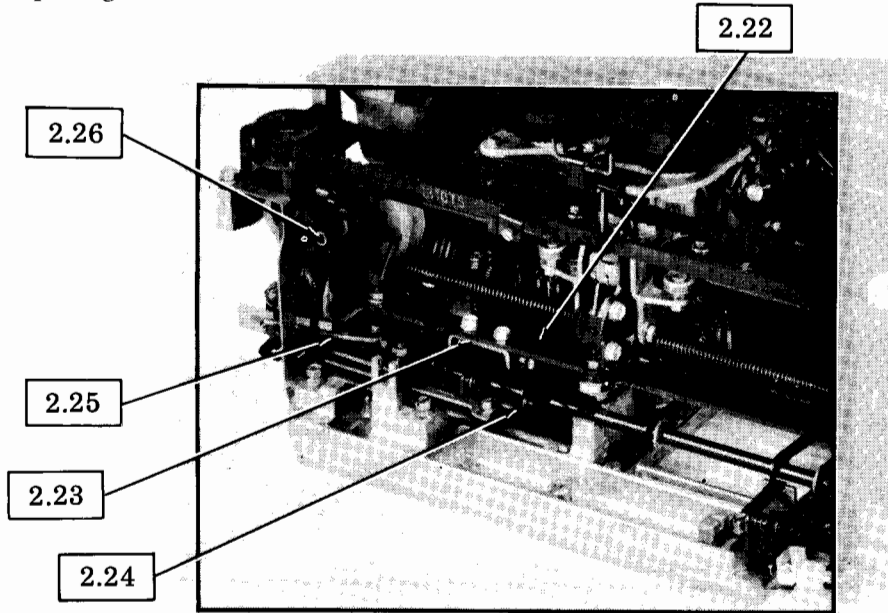

(Left Front View)

2.22 Space Bellcrank

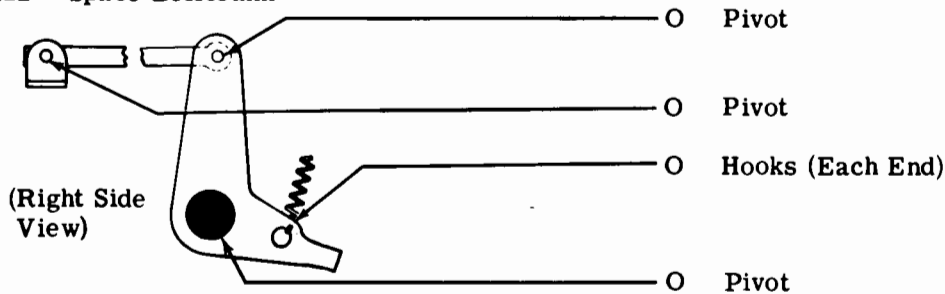

(Right Side View)

- O Pivot Bellcrank
- O Pivot Spacing Lever
- O Hooks (Each End) Spring
- O Pivot Bellcrank

2.23 Drive Mechanism

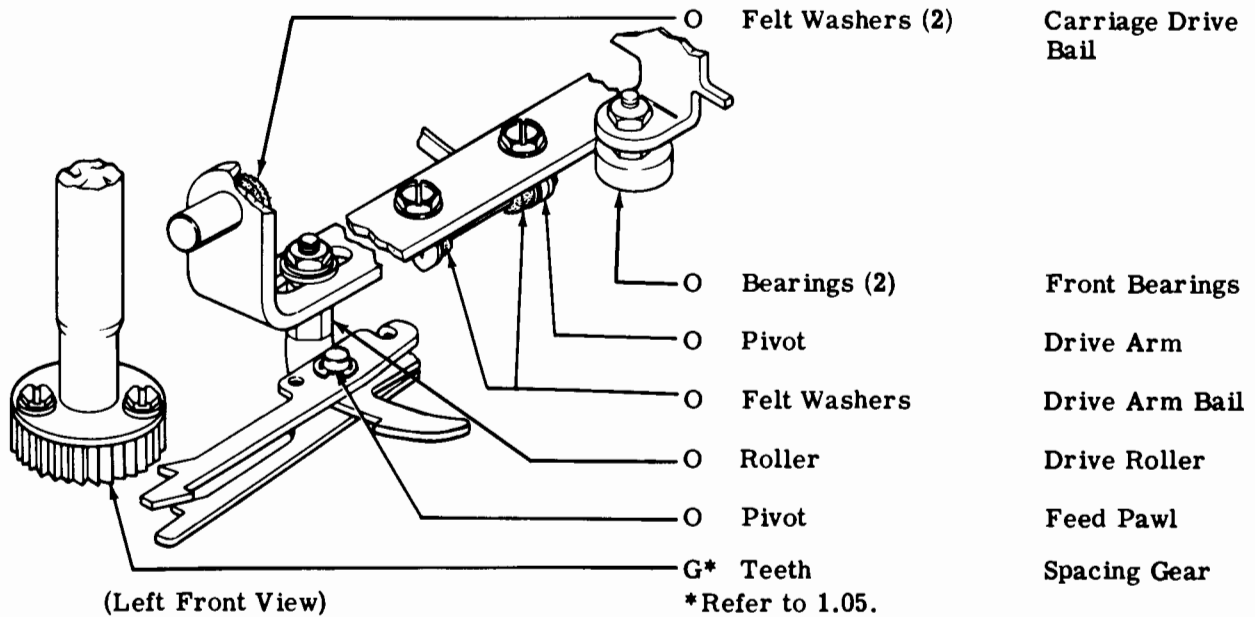

(Left Front View)

G* Teeth
*Refer to 1.05.

2.24 Carriage Return and Spacing Levers

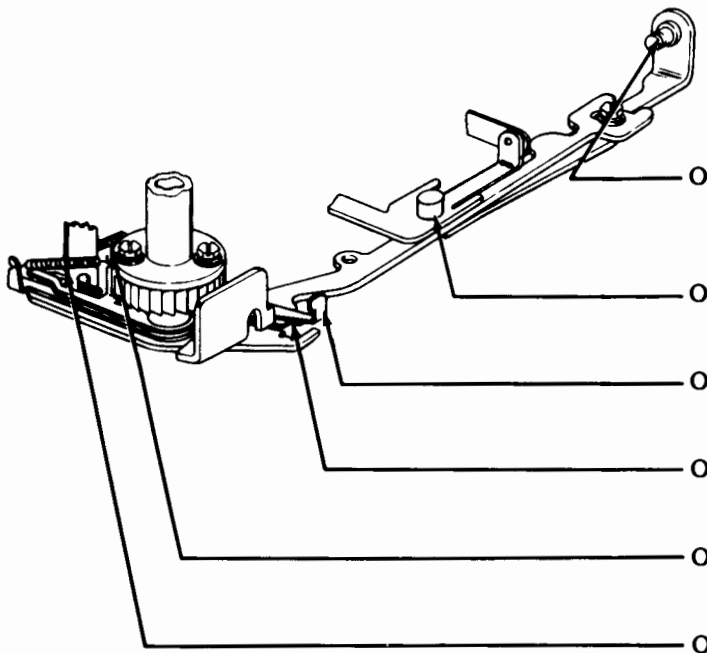

- Pivot Carriage Return Lever
- Pivot Spacing Mechanism
- Engaging Surface Latch
- Latching Surface Latch
- Hooks (Each End) Latch Spring
- Hooks (Each End) Latch Spring

(Left Front View)

2.25 Spacing Mechanism - 1

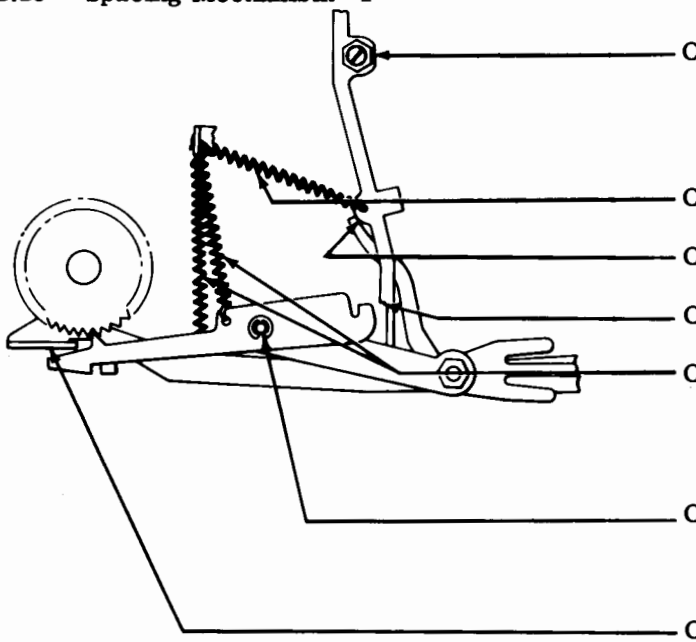

- Pivot Eccentric
- Hooks (Each End) Spring
- Engaging Surface Spacing Lever
- Latching Surface Suppression Lever
- Hooks (Each End) Springs (3)
- Pivot Feed Pawl
- Engaging Surfaces Feed and Check Pawns

(Top View)

2.26 Spacing Mechanism - 2

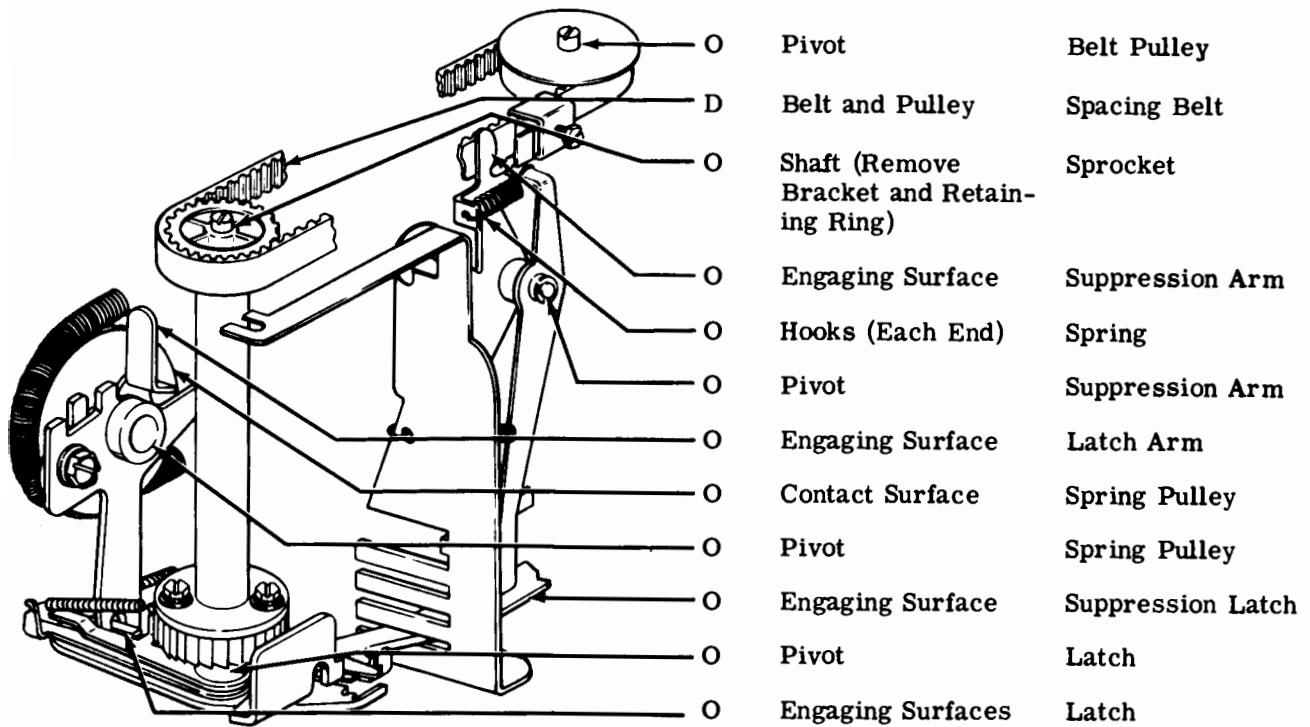

(Left Front View)

2.27 Carriage Area

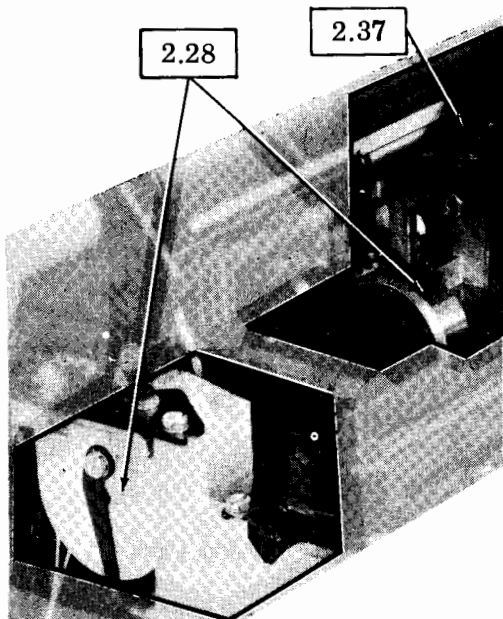

(Left Front View)

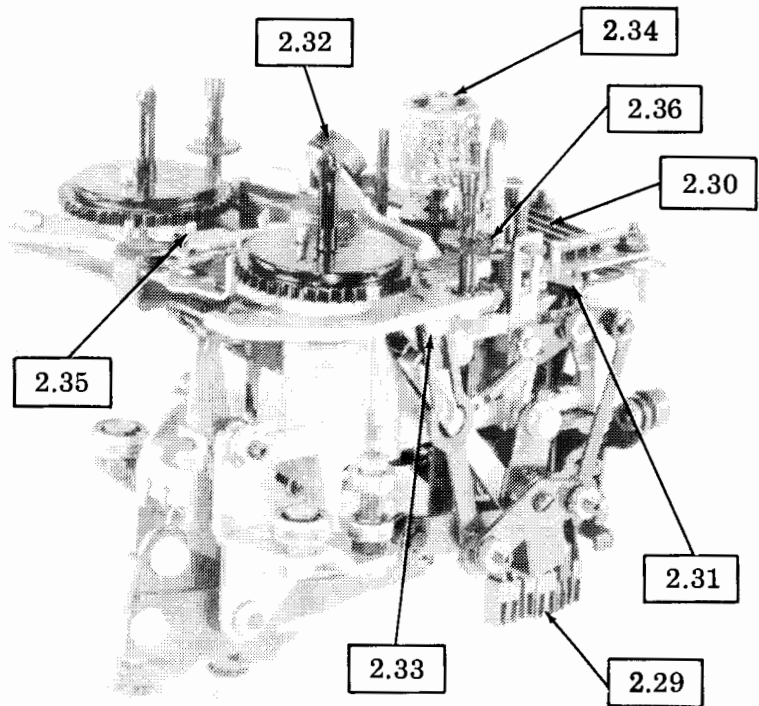

(Right Front View)

Note: Remove ribbon mechanism and carriage return spring before lubricating. For instructions, see the appropriate disassembly and reassembly section.

2.28 Dashpot

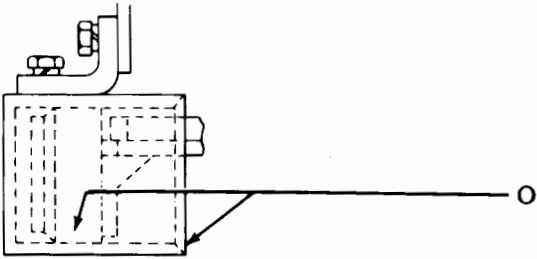

(Front View)

Sliding Surfaces Dashpot and Cylinder
 (Apply with oil dampened cloth. Too much lubricant will cause malfunction.)

2.29 Slides

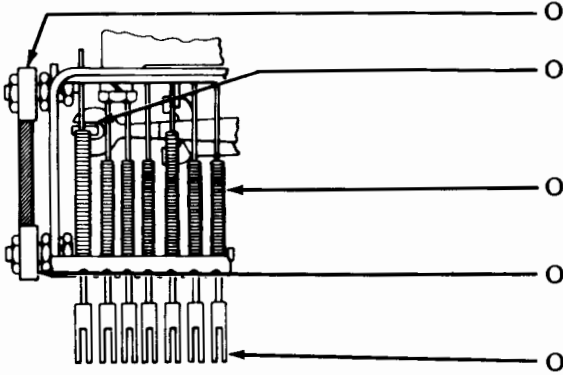

(Left Side View)

Bearing Rear Roller (Top)
 Engaging Surface Suppression Latch Fork
 Seats (Each End) Slide Guide Springs
 Bearing Rear Roller (Bottom)
 Codebar Contacts Slides

2.30 Slide Guideplates

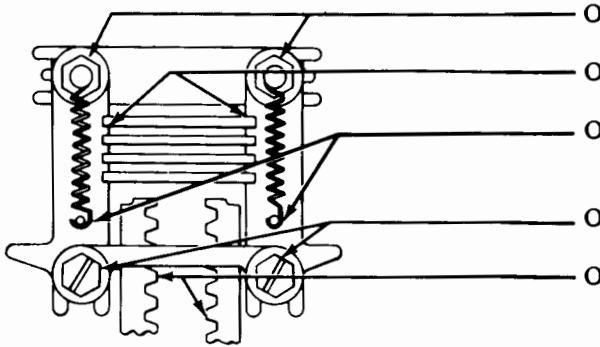

(Top View)

Sliding Contacts Stop Plate
 Engaging Surfaces Stop Slides
 Hooks (Each End) Springs
 Contact Points Slide Guides
 Teeth Pinion Racks

SECTION 574-122-701TC

2.31 Drive Arm

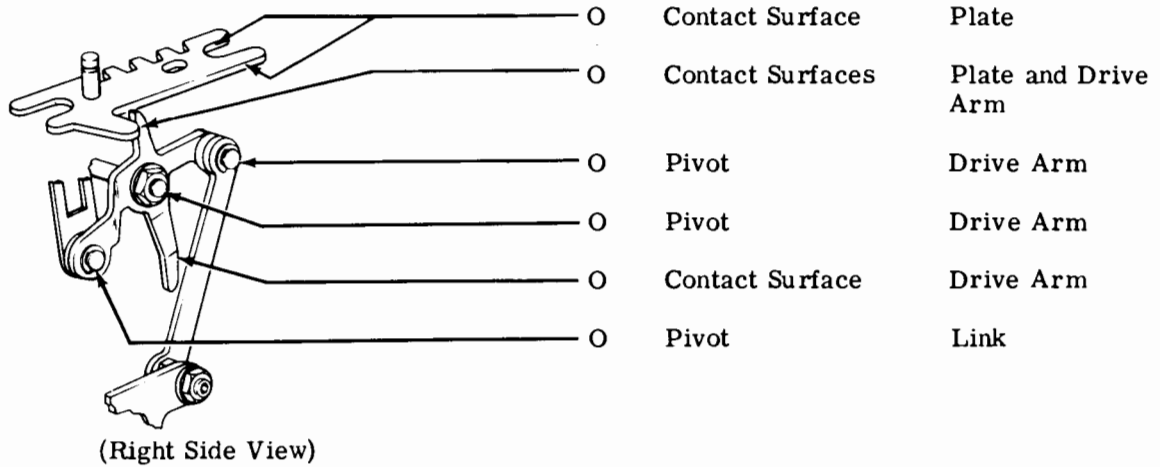

2.32 Print Hammer

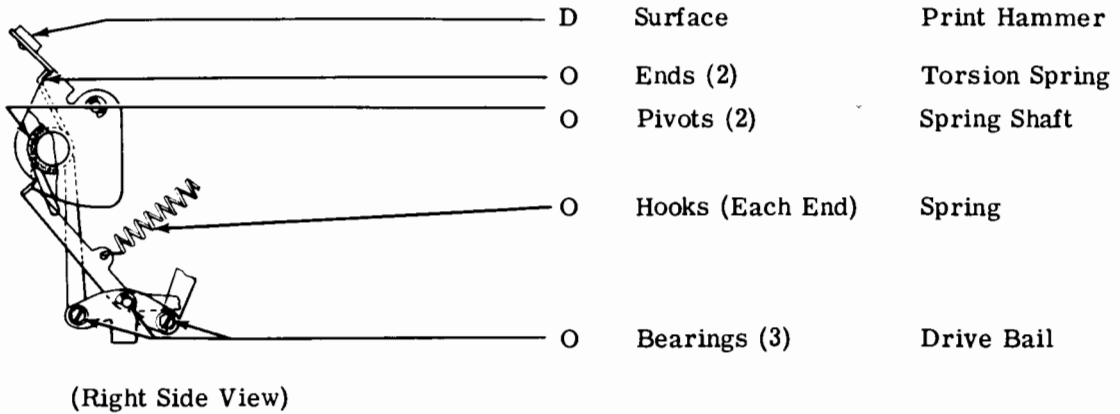

2.33 Reset Arm

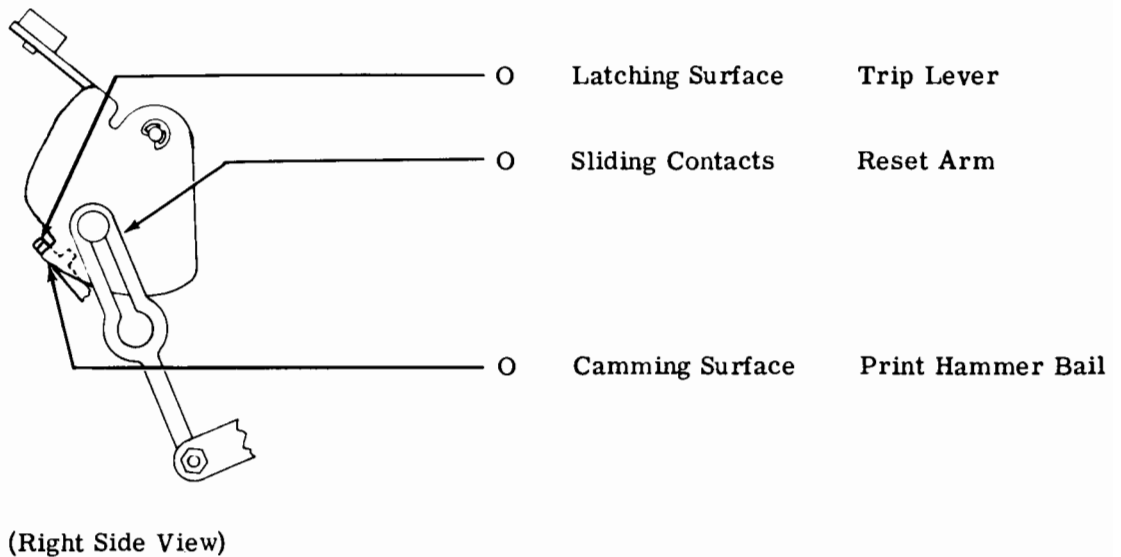

2.34 Typewheel Mechanism

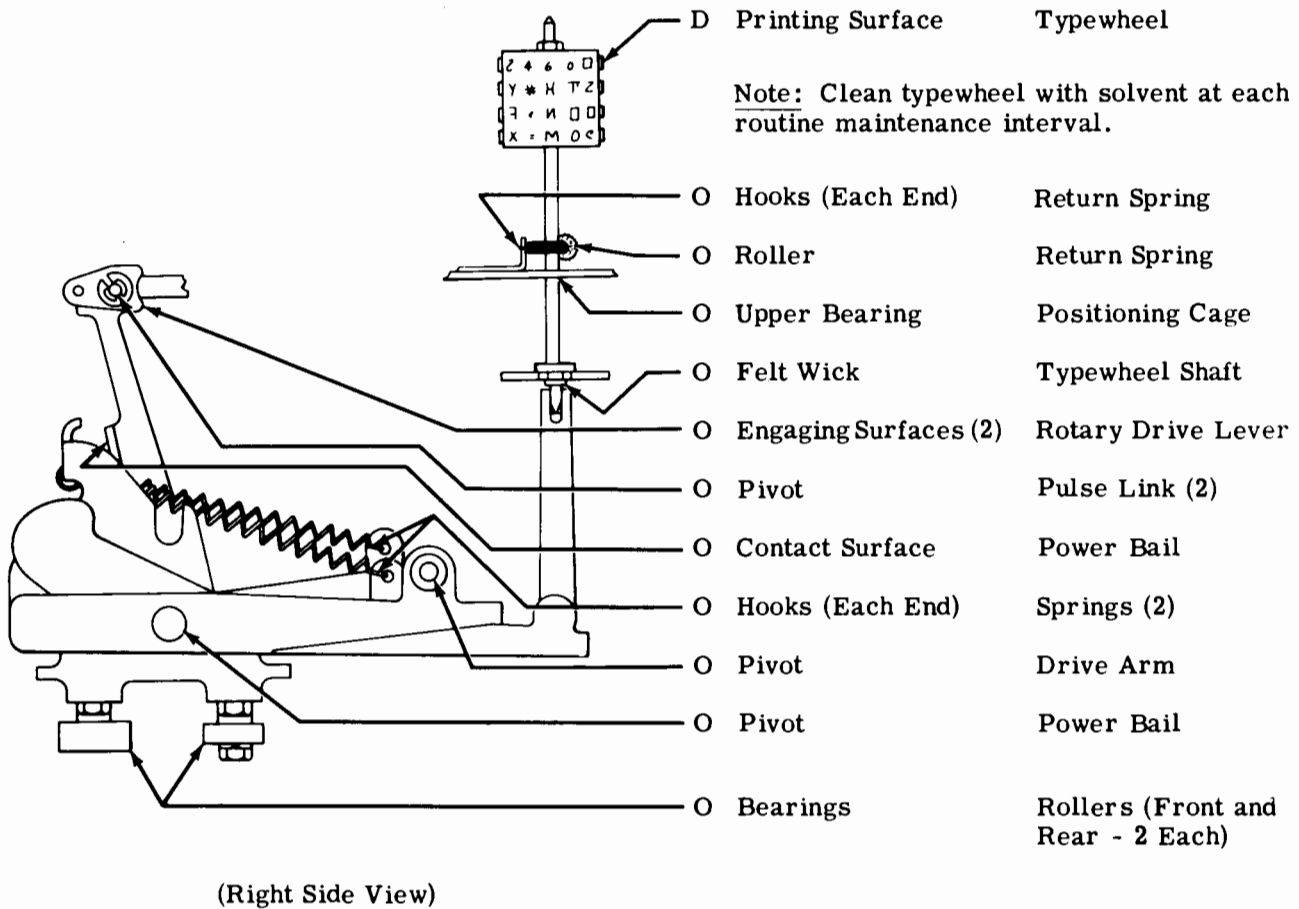

2.35 Ribbon Mechanism

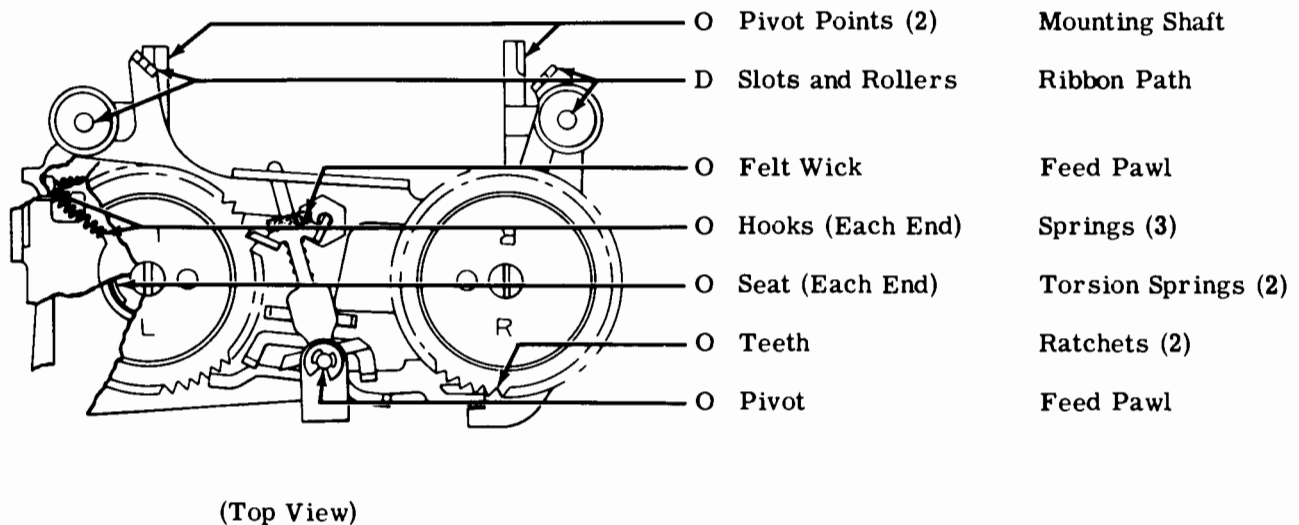

2.36 Ribbon Guide Spring

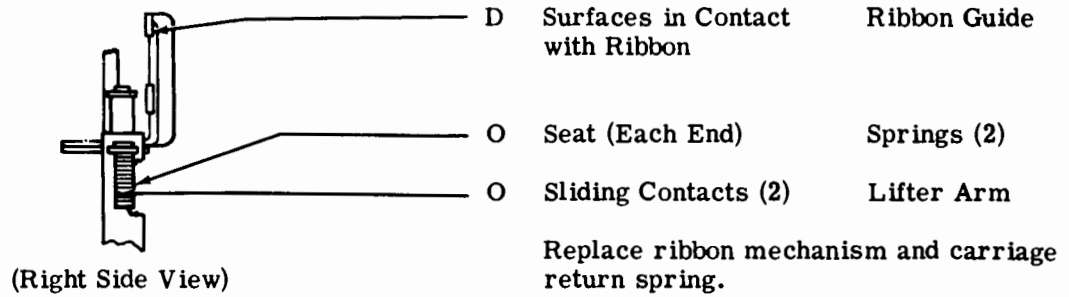

2.37 Carriage Rear Rail

Note: These lubrication instructions apply only to typing units equipped with a TP181304 latch.

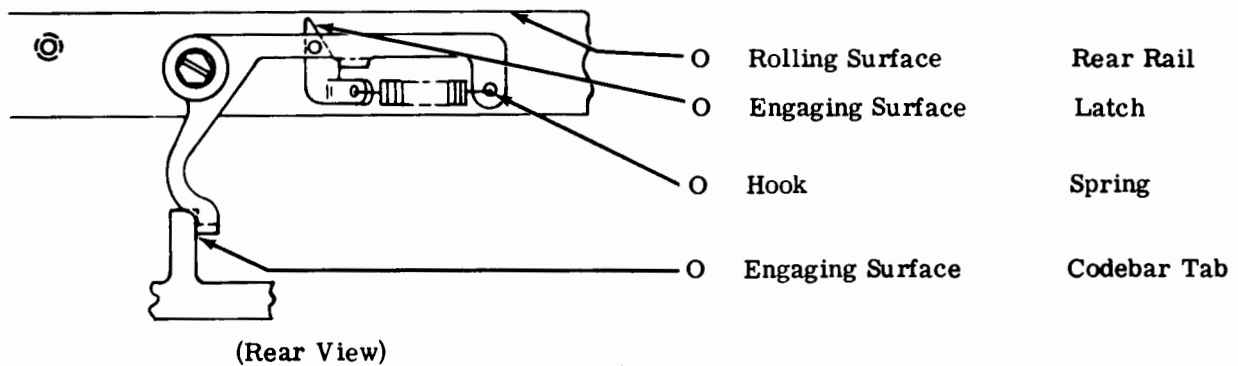

2.38 Selector Area

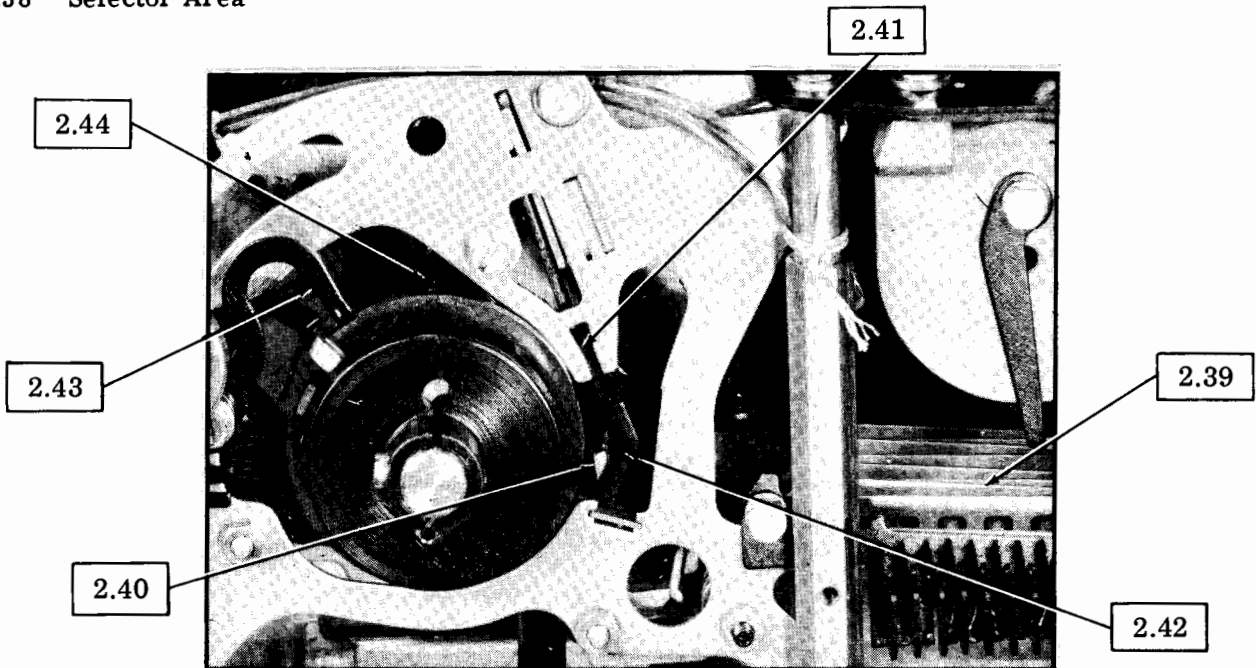

(Left Side View)

2.39 Blocking Levers

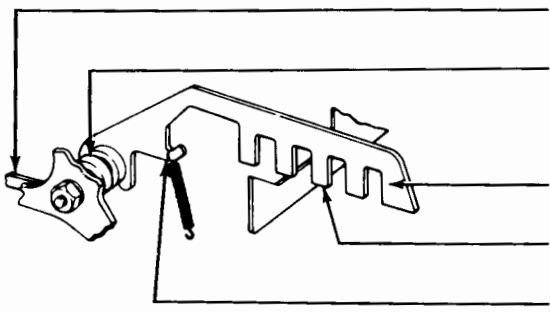

- O Contact Surfaces Blocking Levers
- O Pivots Shaft
- O Engaging Surfaces Codebar Slots
- O Contact Surfaces Tines
- O Hooks Springs

(Left Front View)

2.40 Pushlevers and Stripper Bail

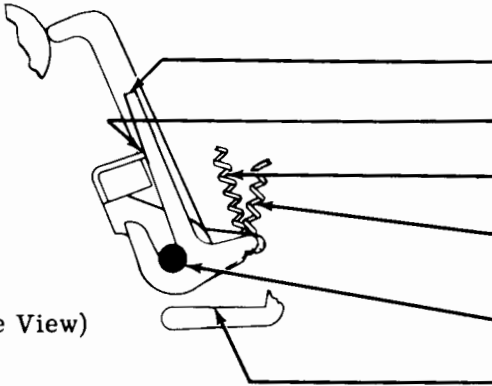

- O Latching Surface Pushlevers
- O Contact Surface Stripper Bail
- O Hooks (Each End) Bail Spring
- O Hooks (Each End) Pushlever Springs
- O Pivots Pushlevers
- O Contact Surfaces Blocking Levers

(Left Side View)

2.41 Armature

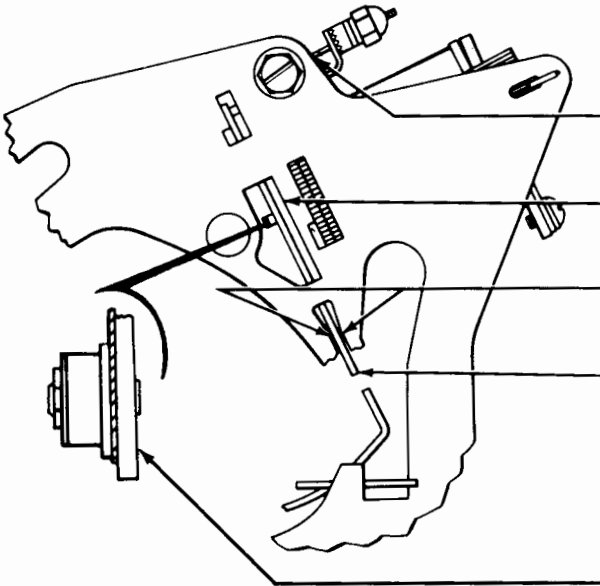

- D Hooks Armature Spring
- D Engaging Surfaces Armature
- O Engaging Surfaces Side Plates
- G Engaging Surface Armature
- D Engaging Surface Armature

(Left Side View)

2.42 Selector Levers

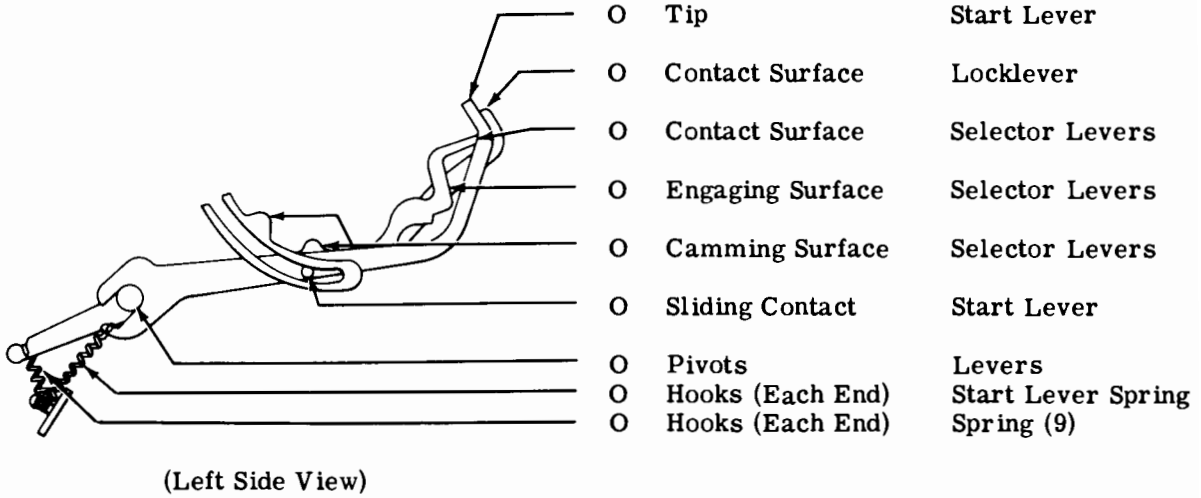

2.43 Latchlever and Trip Lever

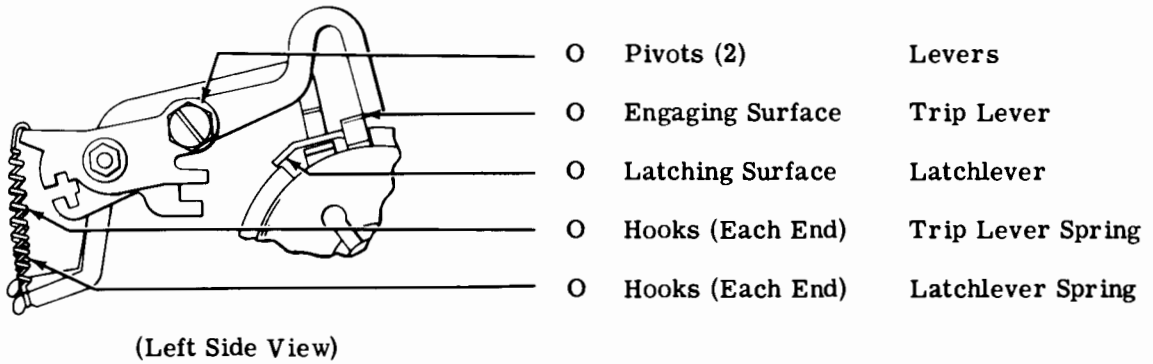

2.44 Selector Clutch

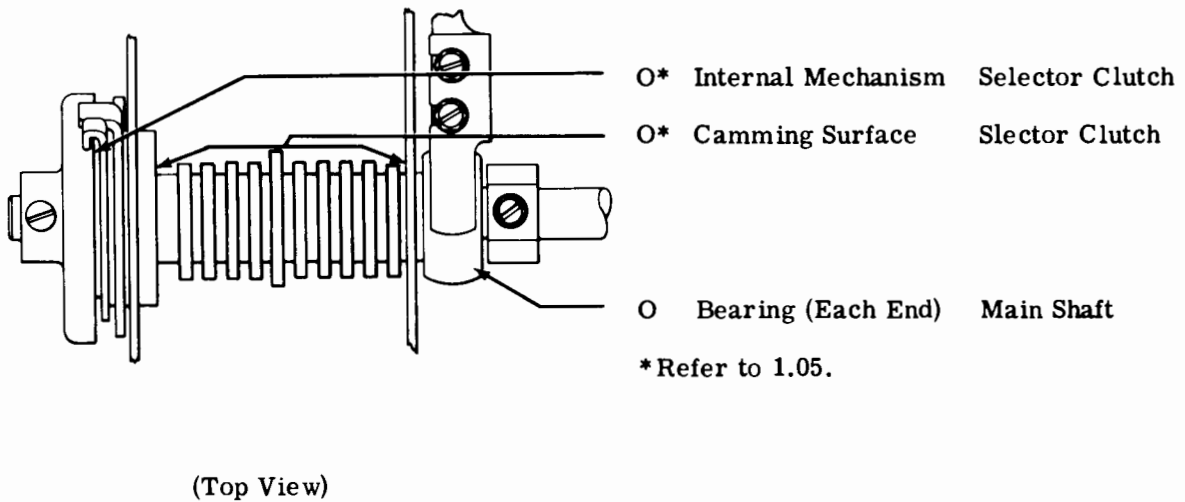

FRICION FEED MECHANISMS

2.45 Paper Feed Area

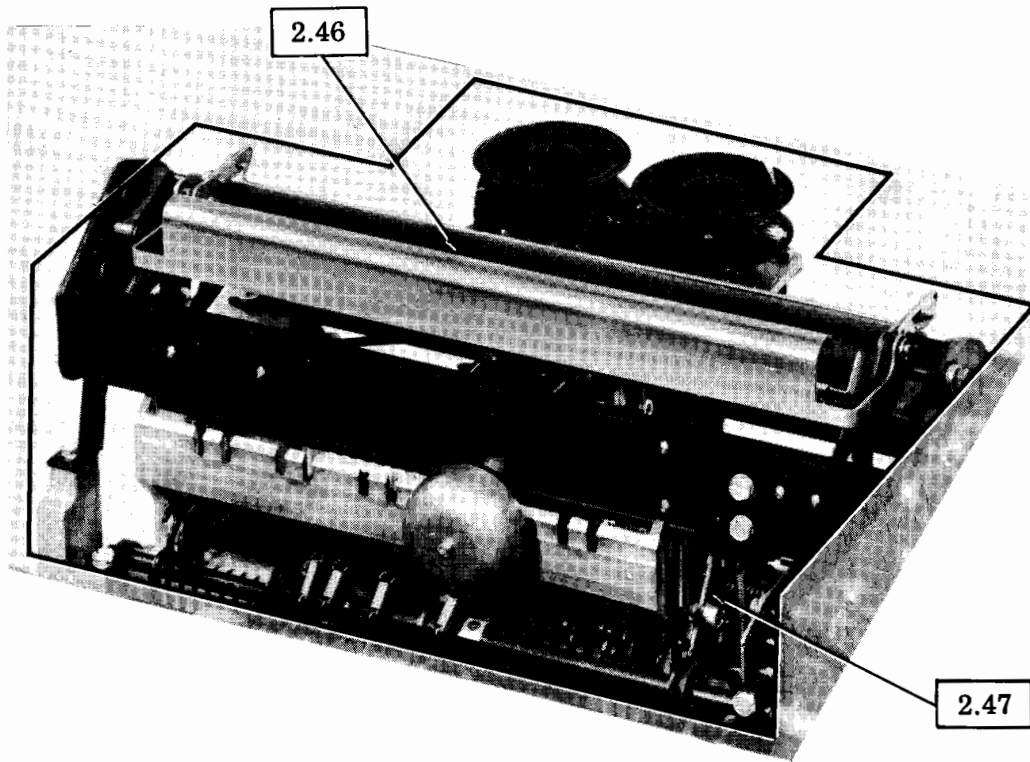

(Rear View)

2.46 Platen

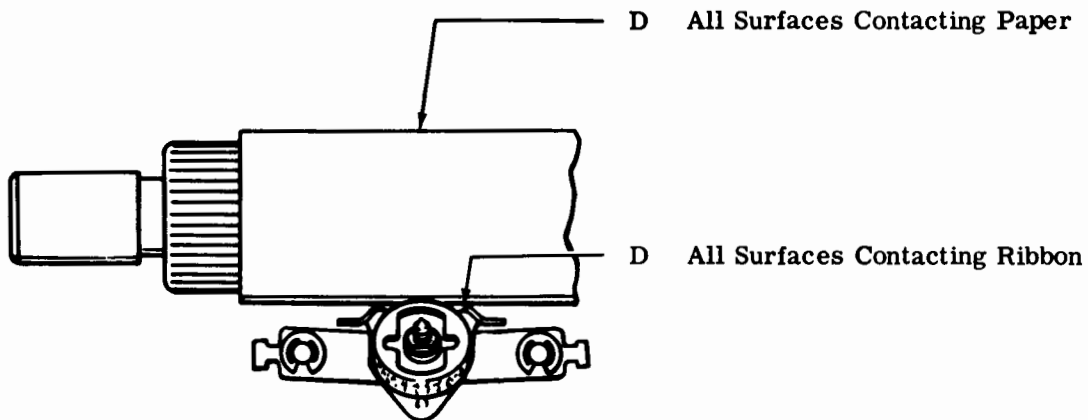

**CAUTION: DO NOT CLEAN PLATEN
WITH SOLVENTS.**

2.47 Line Feed Mechanism

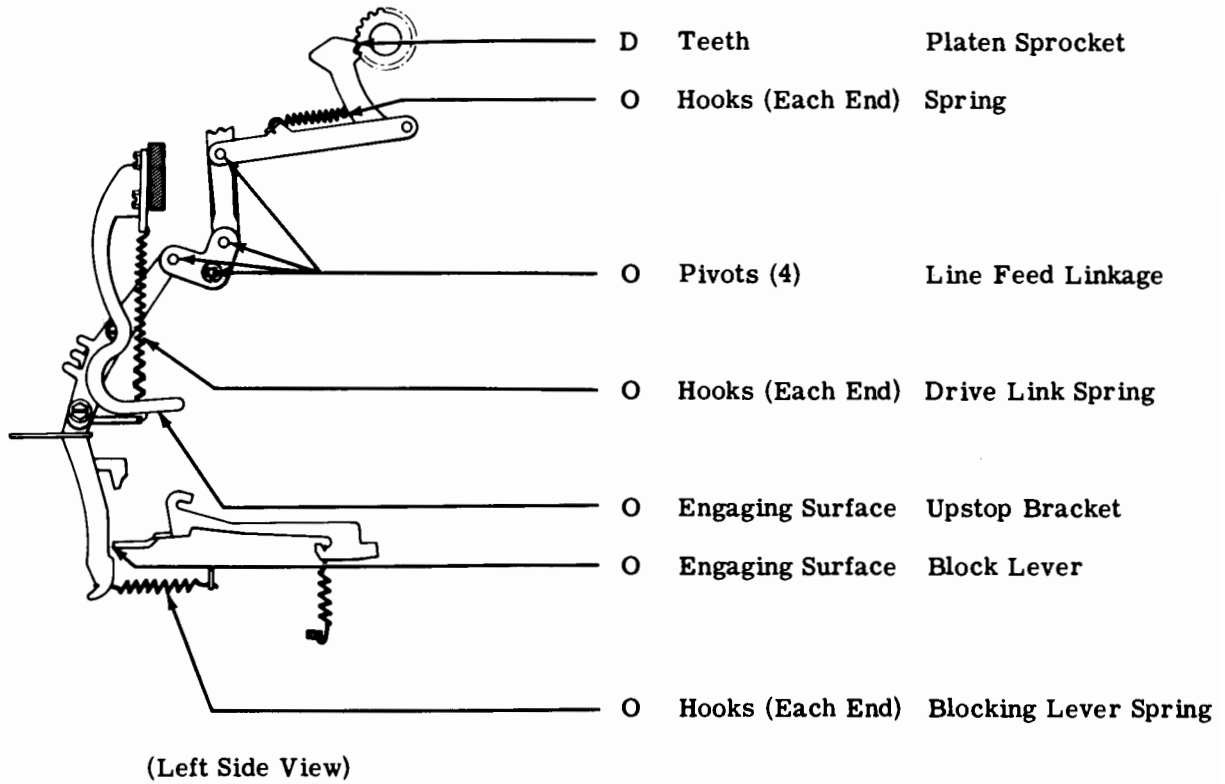

SPROCKET FEED MECHANISMS

2.48 Paper Feed Area

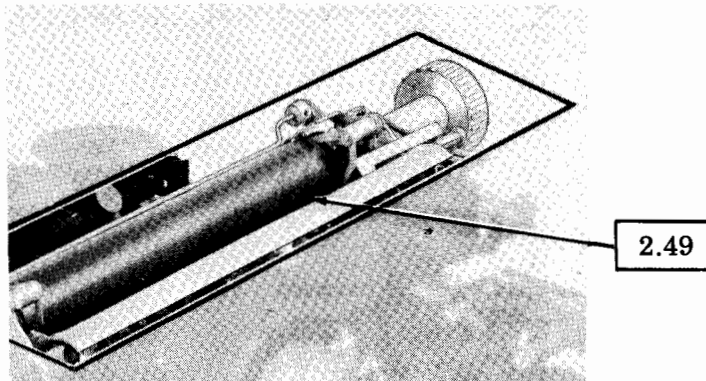

(Right Rear View)

2.49 Platen Mechanism

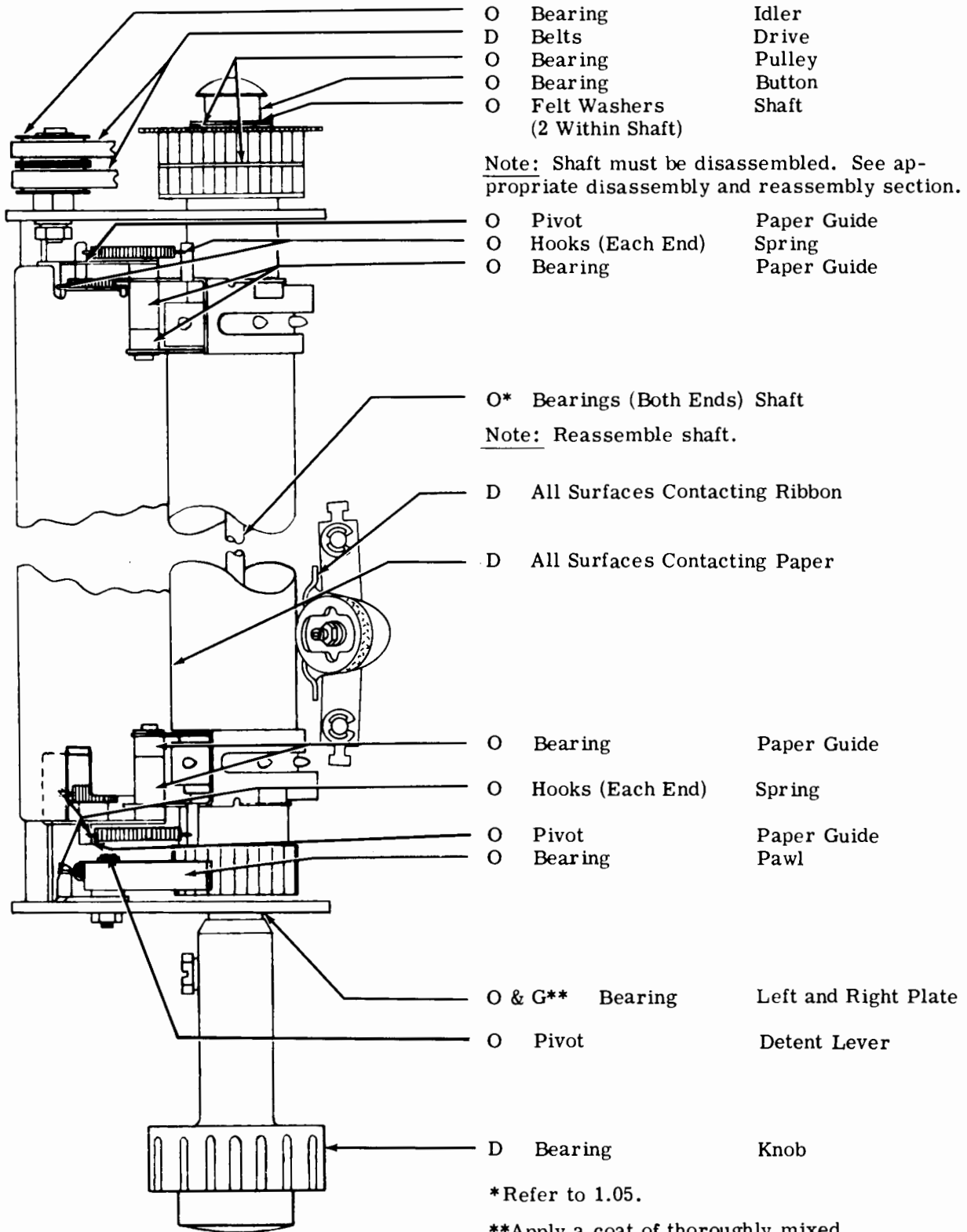

(Top View)

*Refer to 1.05.

**Apply a coat of thoroughly mixed 50 percent KS7470 oil and 50 percent KS7471 grease.

2.50 Platen Drive Area

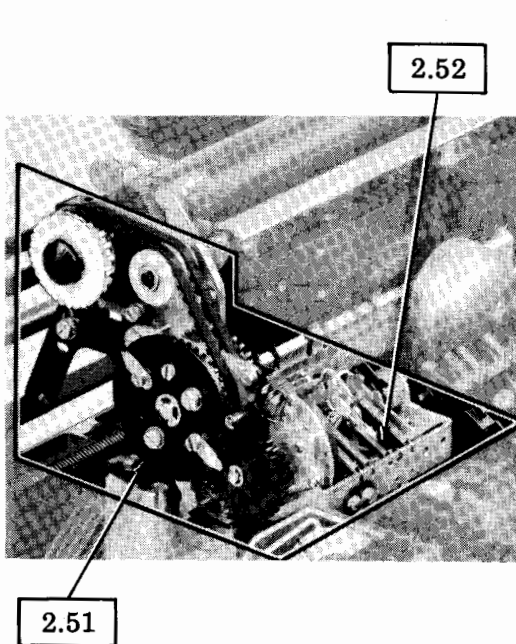

(Right Rear View)

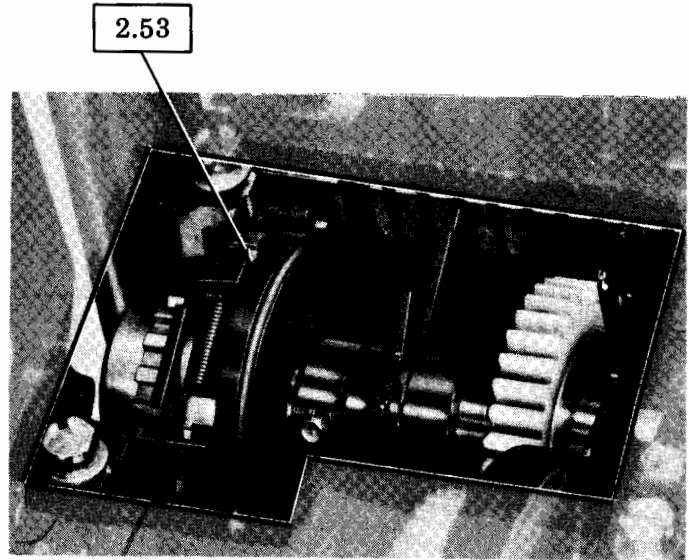

(Left Rear View)

(Form-out mechanism removed for illustration purposes. Removal for lubrication is not required.)

2.51 Cam, Pulley, and Gear Combination

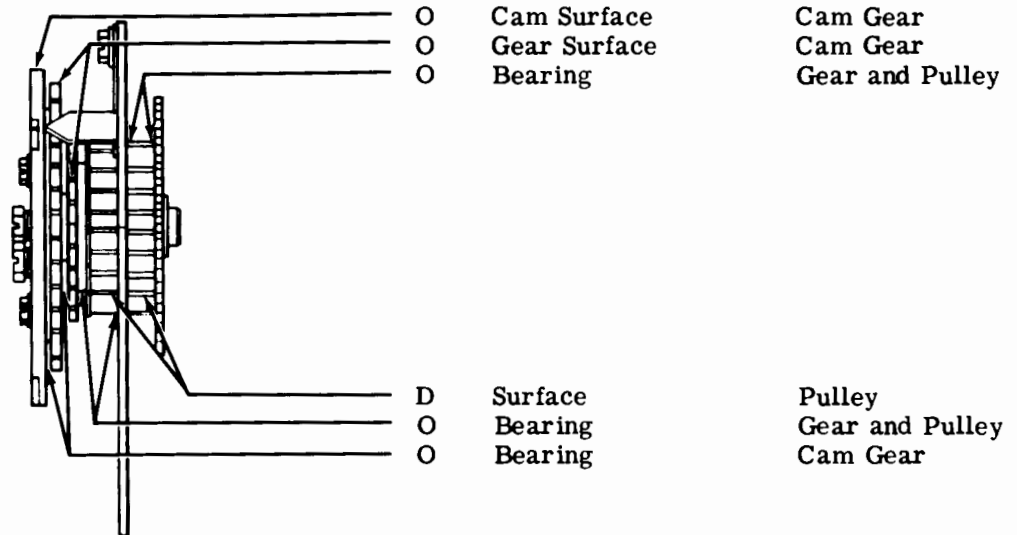

(Top View)

2.52 Form-Out Mechanism

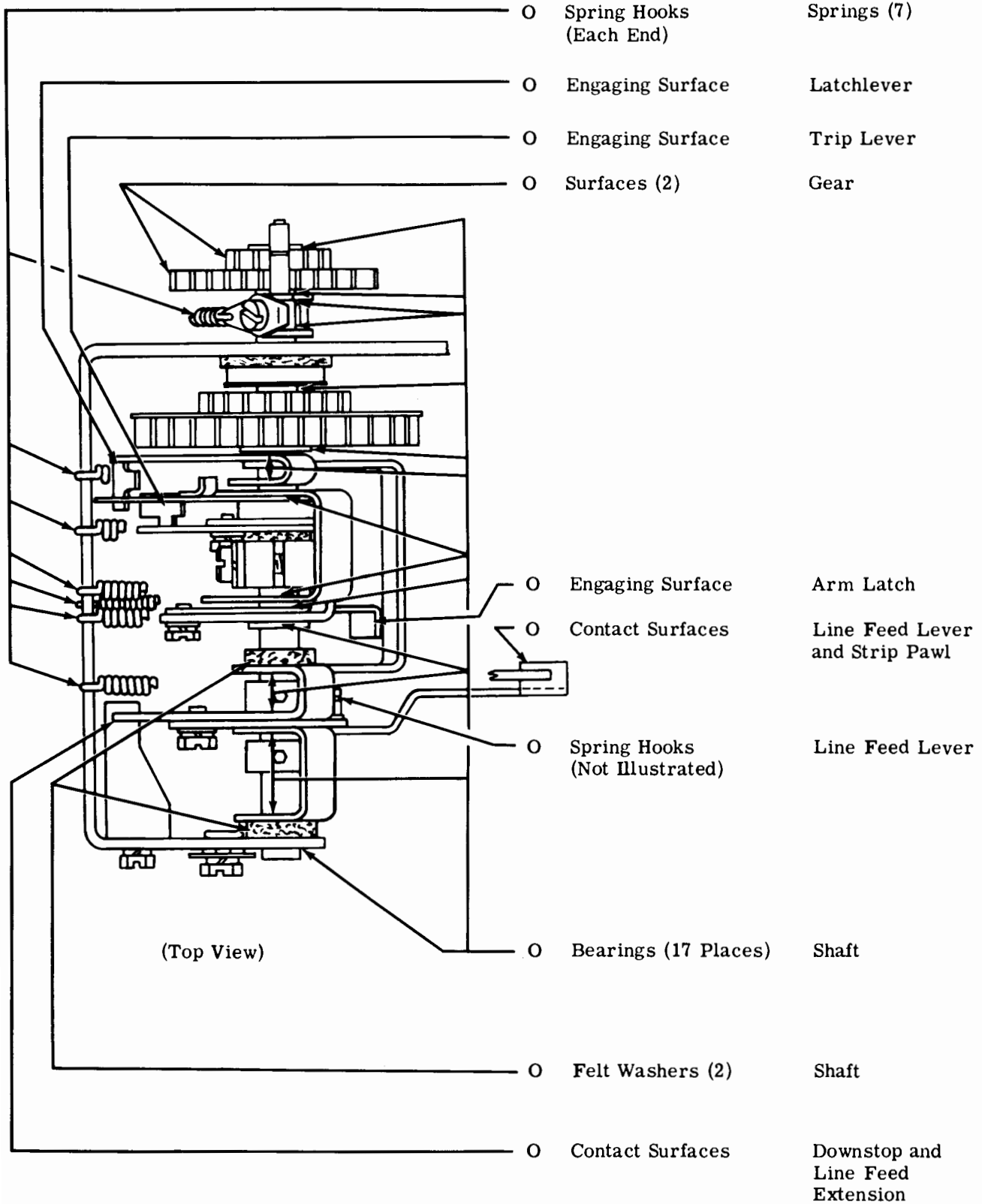

2.53 Line Feed Clutch

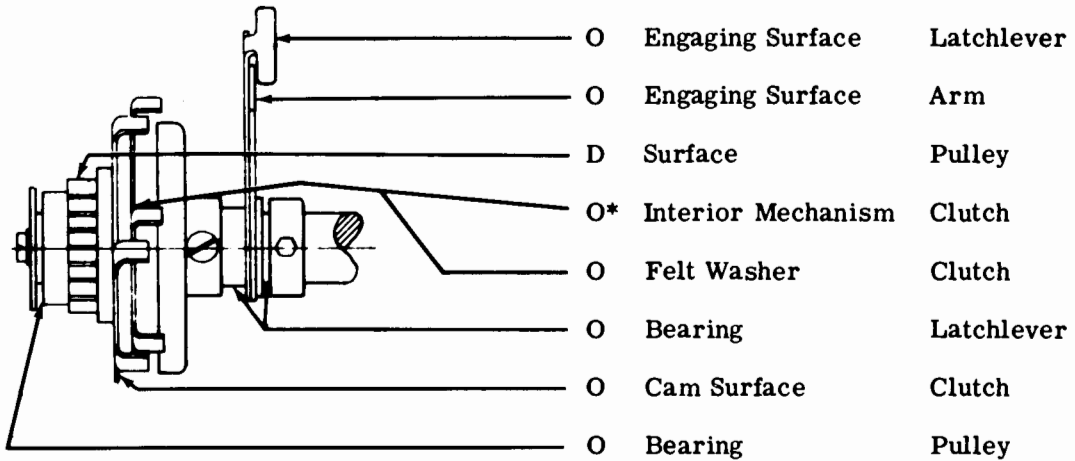

(Top View)

* Refer to 1.05.

3. VARIATIONS TO BASIC UNITS

3.01 Answer-Back Area

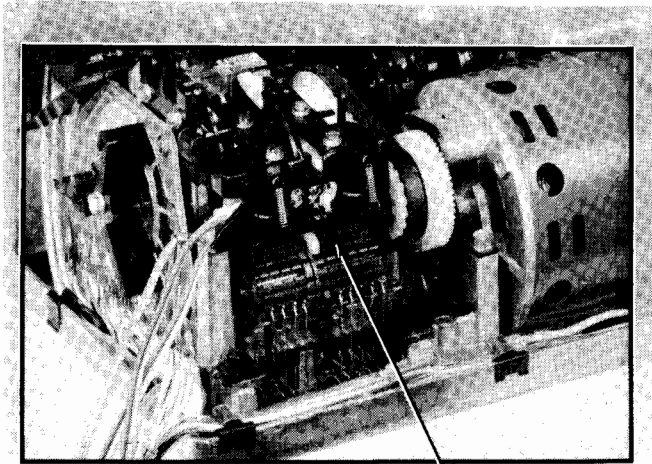

(Left Rear View)

3.03

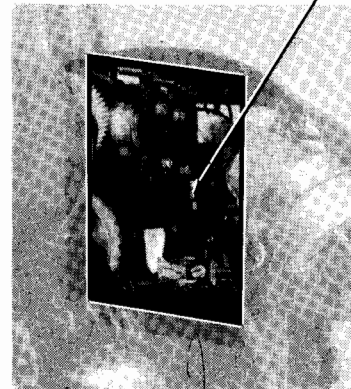

(Left Side View)

3.02

3.02 Trip Magnet

Note: Remove answer-back drum.

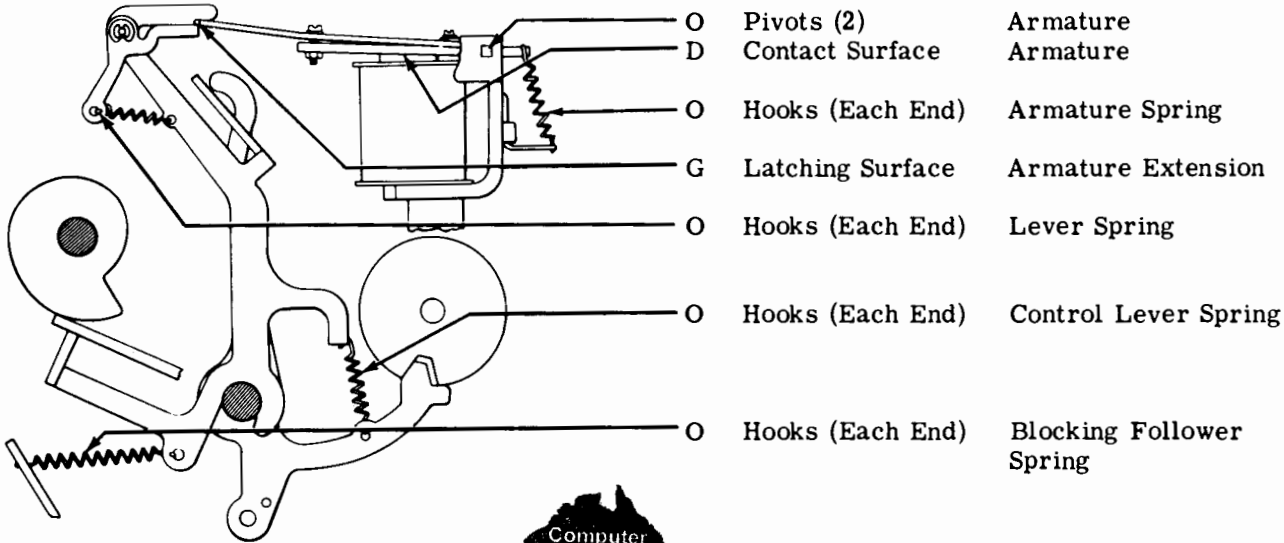

- O Pivots (2) Armature
- D Contact Surface Armature
- O Hooks (Each End) Armature Spring
- G Latching Surface Armature Extension
- O Hooks (Each End) Lever Spring
- O Hooks (Each End) Control Lever Spring
- O Hooks (Each End) Blocking Follower Spring



3.03 Answer-Back Mechanism

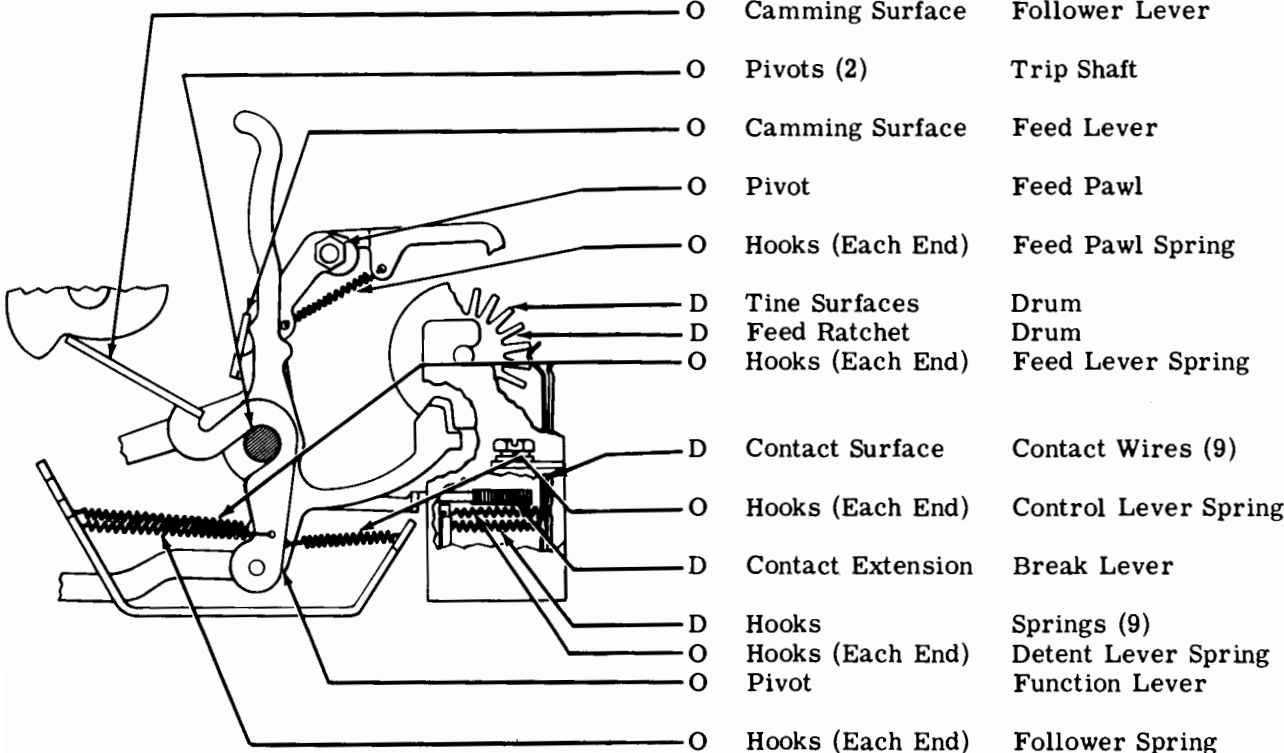

- O Camming Surface Follower Lever
- O Pivots (2) Trip Shaft
- O Camming Surface Feed Lever
- O Pivot Feed Pawl
- O Hooks (Each End) Feed Pawl Spring
- D Tine Surfaces Drum
- D Feed Ratchet Drum
- O Hooks (Each End) Feed Lever Spring
- D Contact Surface Contact Wires (9)
- O Hooks (Each End) Control Lever Spring
- D Contact Extension Break Lever
- D Hooks Springs (9)
- O Hooks (Each End) Detent Lever Spring
- O Pivot Function Lever
- O Hooks (Each End) Follower Spring

Note: Replace answer-back drum.

CAUTION: DO NOT CLEAN CONTACT BLOCK WITH SOLVENTS.

3.04 Print Nonprint Mechanism (Units So Equipped)

Note: These lubrication instructions apply to both the magnet operated and solenoid operated print nonprint mechanisms.

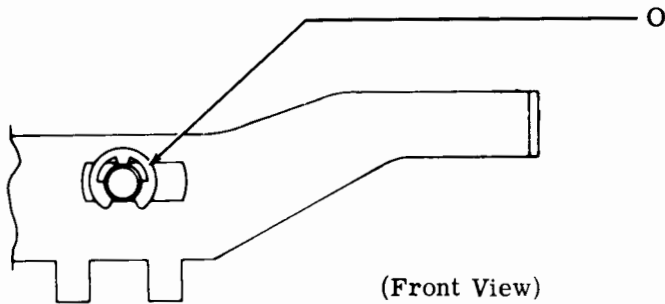

Contact Surface

Nonprint Codebar
Mounting Posts
(Each End of
Codebar)

(Front View)

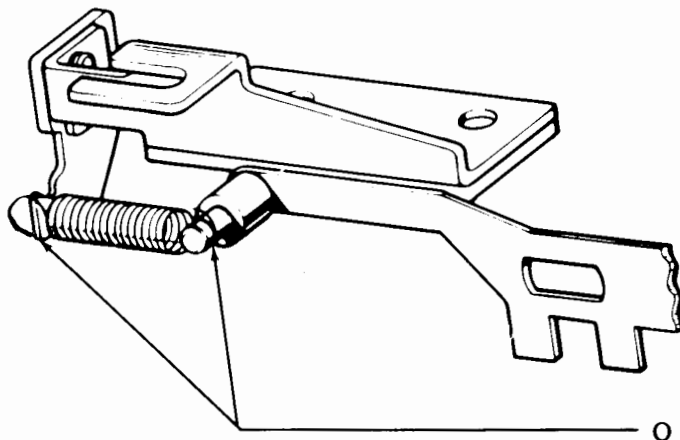

Hooks (Each End)

Nonprint Codebar
Return Spring

(Right Front View)

33 TYPING UNIT
DISASSEMBLY AND REASSEMBLY

CONTENTS	PAGE	
1. GENERAL	1	1. GENERAL
2. DISASSEMBLY AND REASSEMBLY ..	2	
RIBBON MECHANISM	2	1.01 This section provides disassembly and reassembly information for the 33 typing unit. It is reissued to include instructions concerning the downstop bracket for the form-out mechanism on sprocket feed units. Marginal arrows indicate additions and changes.
CARRIAGE MECHANISM	2	1.02 References to left, right, front, rear, etc, consider the typing unit to be viewed from a position where the ribbon mechanism faces up and the selector mechanism is located to the viewer's left.
CARRIAGE DRIVE BAIL	3	
CODEBAR MECHANISM	4	
CODEBAR RESET BAIL	4	1.03 The disassembly procedure given in this section divides the typing unit into its major assemblies and mechanisms. If further disassembly is required, refer to the appropriate illustrated parts section which shows detailed arrangements of parts. Where it will help in determining location, the numbers of the parts are given in the instructions.
SPACING PAWL MECHANISM	4	
FUNCTION LEVER MECHANISM ...	5	
SPACING DRUM MECHANISM	5	
DISTRIBUTOR TRIP SHAFT MECHANISM	5	CAUTION: BEFORE BEGINNING DISASSEMBLY, REMOVE CONNECTORS FROM EXTERNAL RECEPTACLES (POWER SOURCE, DATA SET, ETC).
DISTRIBUTOR MECHANISM	6	
FUNCTION ROCKER SHAFT MECHANISM	7	1.04 Most of the mechanisms are mounted on castings by self-tapping screws. Therefore, to remove the mechanisms, do not remove the screws, merely loosen them unless specifically instructed otherwise.
FUNCTION BOX MECHANISM	7	
PLATEN MECHANISM	7	
A. Friction Feed	7	
B. Sprocket Feed	7	1.05 Retaining rings are made of spring steel and have a tendency to release suddenly. To avoid loss of these rings when removing them, proceed as follows.
FORM-OUT MECHANISM	7	(a) Hold retaining ring to prevent it from rotating.
TRIP SHAFT MECHANISM	9	(b) Place blade of screwdriver in one of the ring's slots and rotate screwdriver to increase diameter.
SELECTOR MECHANISM	9	(c) Ring will come off easily in fingers without flying.
MAIN SHAFT MECHANISM	10	
MOTOR	11	

SECTION 574-122-702TC

1.06 All tools used to remove the mechanisms referred to in this section can be found in the 570-005-800TC standard tool section.

1.07 All damaged, worn, or distorted parts should be replaced if encountered in the disassembly and reassembly procedures.

2. DISASSEMBLY AND REASSEMBLY

→ Note: For information concerning the proper procedure to remove the typing unit from the set, refer to Section 574-100-702TC.

RIBBON MECHANISM

2.01 To remove ribbon mechanism (Figure 1), proceed as follows.

(a) Remove ribbon by removing the two ribbon spools and disengaging the ribbon from the ribbon guide and the TP183324 reverse arm.

(b) Loosen the two TP152893 mounting screws and lift ribbon mechanism from carriage.

(c) To replace ribbon mechanism, reverse procedure used to remove it.

CARRIAGE MECHANISM

2.02 To remove carriage mechanism (Figure 1), proceed as follows.

(a) Unhook carriage return spring from carriage.

(b) Loosen the two TP180798 mounting screws in spacing pulley mounting bracket. Rotate and remove bracket.

(c) Loosen the two TP180798 mounting screws in spacing drum mounting bracket. Remove mounting bracket.

(d) Disengage spacing belt from pulley on spacing drum.

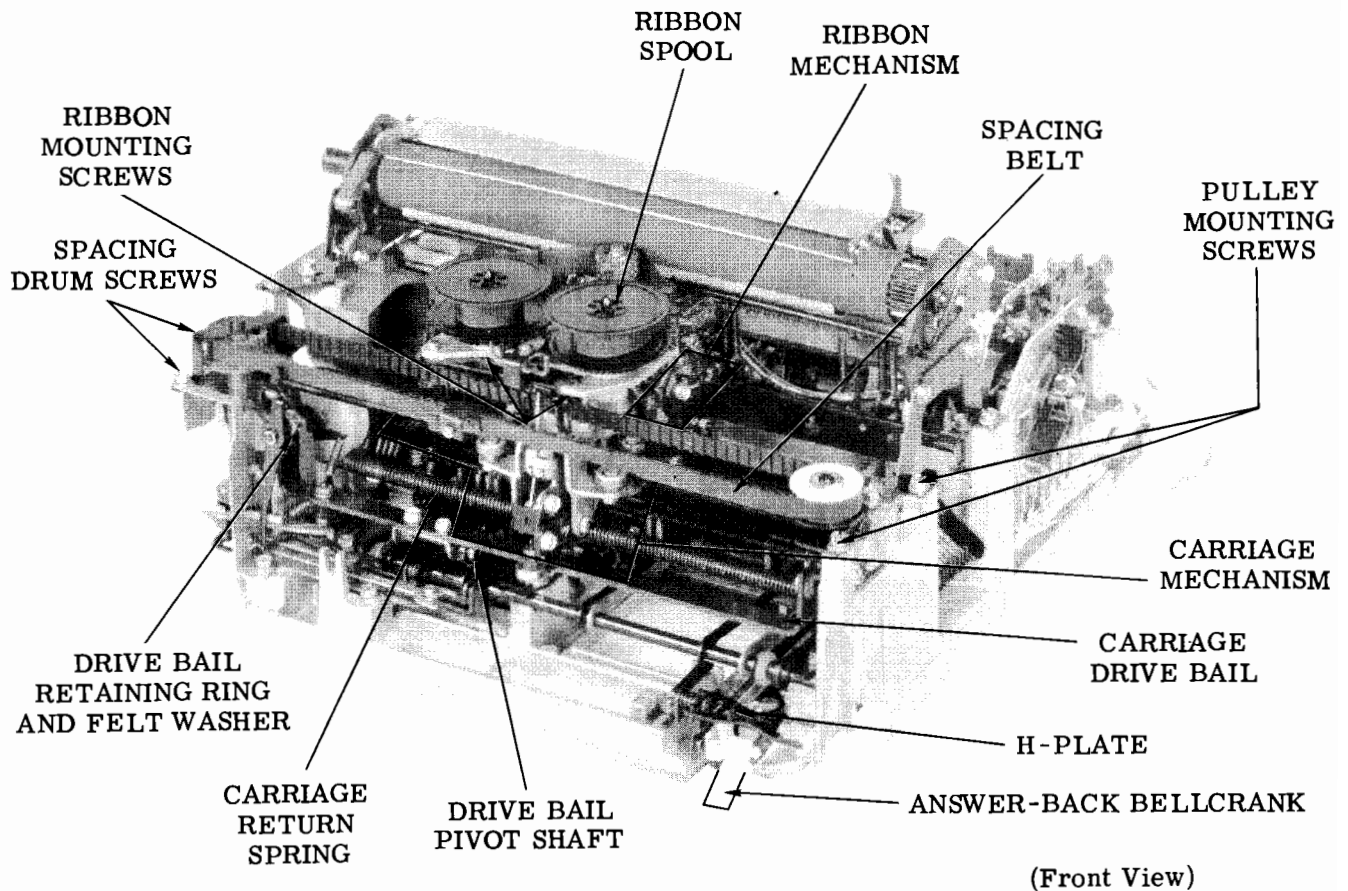

Figure 1 - Typing Unit

- (e) Remove front carriage shaft by sliding it to the right.
- (f) To disengage the rollers from the drive bail, slightly lift the front of the carriage. Rotate the carriage to the left and disengage the slide guides from the codebars.
- (g) Lift the carriage from the unit.
- (h) To replace the carriage mechanism, reverse the procedure used to remove it and observe the following precautions.

- (1) Make sure nylon slide guides engage proper associated codebars.
- (2) Make sure two rear rollers engage carriage rear plate.

CARRIAGE DRIVE BAIL

2.03 To remove carriage drive bail (Figures 1 and 2), proceed as follows.

- (a) Remove the carriage mechanism (2.02).

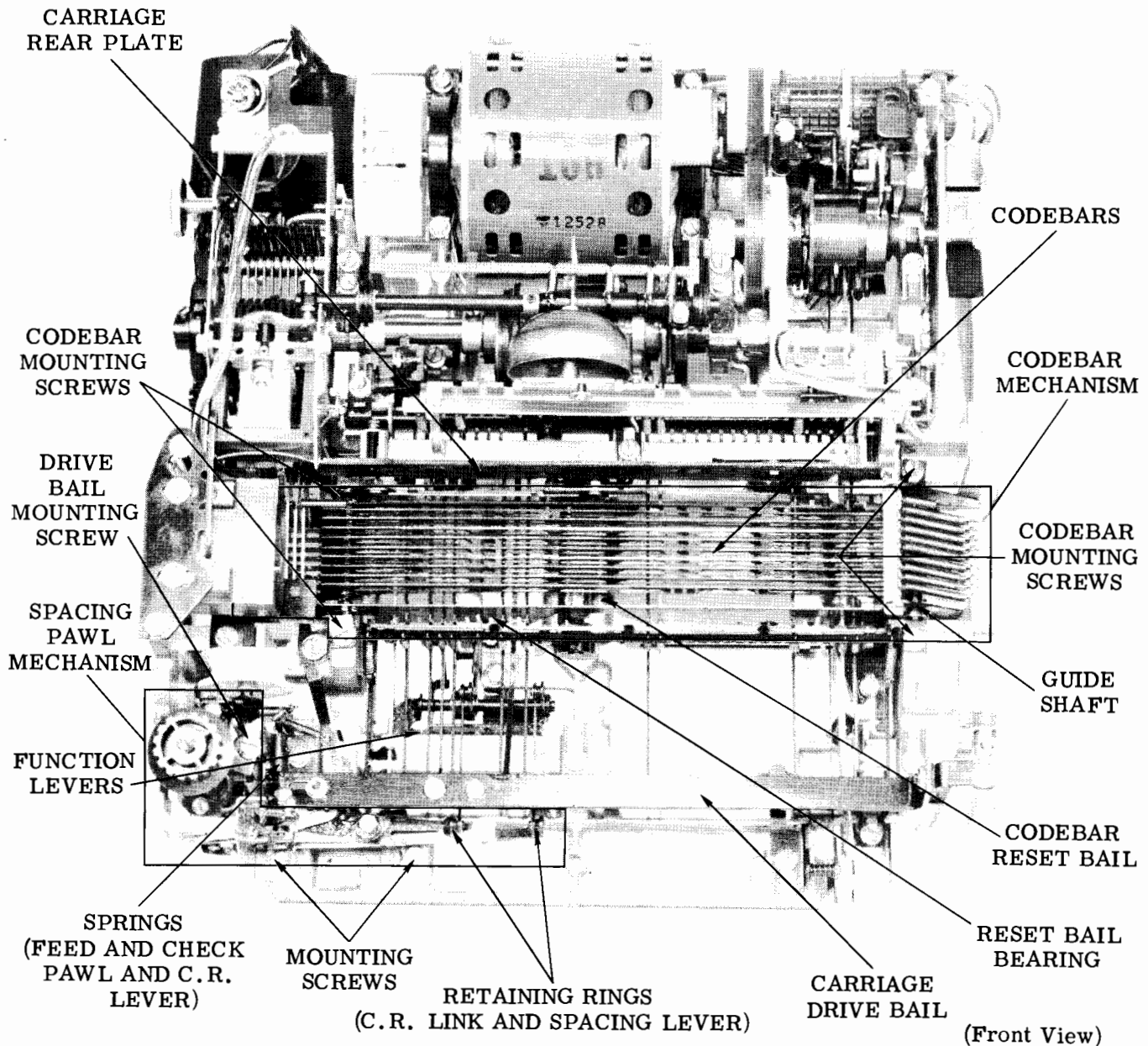

Figure 2 - Typing Unit (Carriage and Platen Removed)

SECTION 574-122-702TC

- (b) Remove the TP3598 nut from the TP180546 post.
- (c) Loosen the TP180798 mounting screw and remove the TP181230 clamp plate at left end of carriage drive bail.
- (d) Remove the TP119651 retaining ring and felt washer at right end of bail.
- (e) Remove drive bail by sliding it to left.
- (f) To replace drive bail assembly, reverse procedure used to remove it.

CODEBAR MECHANISM

2.04 To remove codebar mechanism (Figure 4), proceed as follows.

- (a) Remove the carriage mechanism (2.02).
- (b) Loosen the TP180798 mounting screw and remove the TP180682 upstop bracket. Tighten the TP180798 mounting screw to secure the TP181230 retaining plate to the base casting.
- (c) Remove the TP180788 carriage rear rail.
- (d) Remove the TP180959 bracket.
- (e) Rotate the main shaft so that the TP180751 lever is positioned on the low part of the codebar cam.
- (f) Loosen the four TP180798 mounting screws and remove the four TP180925 clamps.
- (g) Lift the blocking levers from the guide slots and lift the codebar mechanism from the frame.
- (h) To replace codebar mechanism, reverse procedure used to remove it and observe the following precautions.

- (1) Make sure function levers are in proper slots in codebars.
- (2) Make sure codebars reset extensions are to right of TP180928 codebar reset ball and in proper slots of guide.
- (3) Make sure both right and left TP180920 guide shafts are fully seated in their mountings.

(4) Make sure the TP181070 space suppression lever is to the left of the TP180947 print suppression codebar.

(5) Make sure the TP180752 print suppression latch lever fits into slot of the TP180923 bracket mounted on the rear tie bracket.

(6) Make sure that the left ends of the codebars fully engage their respective blocking lever tines.

CODEBAR RESET BAIL

2.05 To remove codebar reset bail (Figures 2 and 3), proceed as follows.

- (a) Remove the codebar spring.
- (b) Remove the TP125252 spring from the TP180773 plate.
- (c) From underside of base casting remove the two TP181245 screws from the two TP180930 bearings.
- (d) Lift the TP180928 codebar reset bail from base casting.
- (e) To replace codebar reset bail, reverse the procedure used to remove it. When replacing the TP181245 screws, make sure that one of them passes through the TP180776 spring bracket before it enters the bearing.

SPACING PAWL MECHANISM

2.06 To remove spacing pawl mechanism (Figure 2), proceed as follows.

- (a) Unhook the TP74701 spring from the TP181067 feed pawl, the TP70466 spring from the TP181065 check pawl, and the TP70388 spring from the TP181319 carriage return lever.
- (b) Remove the TP119649 retaining rings from the TP181314 carriage return link and the TP181068 spacing lever.
- (c) Remove carriage mechanism (2.02).
- (d) Remove spacing drum mechanism (2.08).
- (e) Loosen the two TP180798 mounting screws.

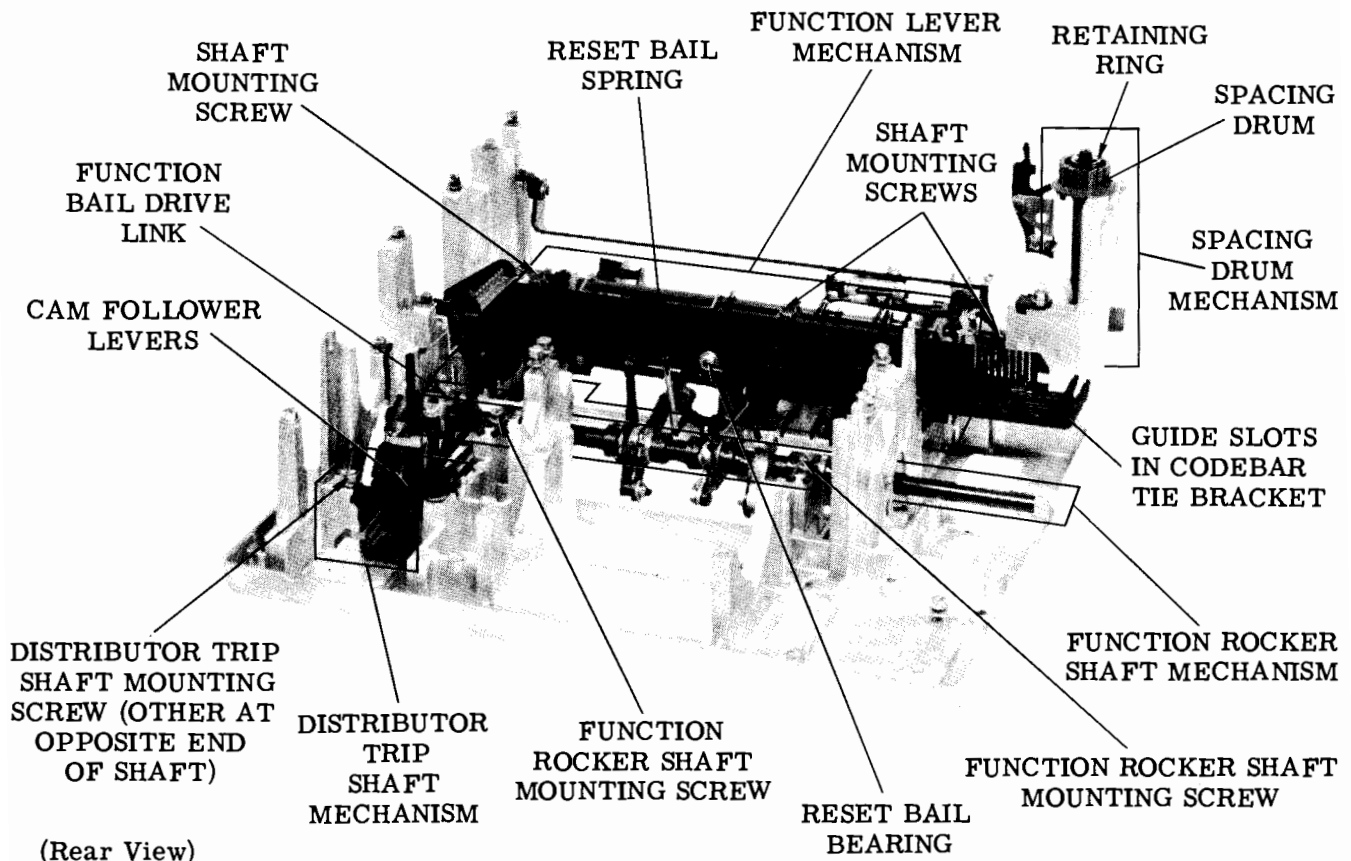

Figure 3 - Typing Unit (A Number of Mechanisms Removed)

- (f) Lift spacing pawl mechanism from base casting.
- (g) To replace spacing pawl mechanism, reverse the procedure used to remove it.

FUNCTION LEVER MECHANISM

- 2.07 To remove function lever mechanism (Figure 3), proceed as follows.
- (a) Loosen the three TP180798 mounting screws and rotate levers pivot shaft so flat side is vertical.
 - (b) To remove any function lever, unhook its spring and disengage lever from pivot shaft.
 - (c) To remove levers pivot shaft, remove the two TP180797 clamp plates and the TP180795 spring bracket. Lift out shaft with two drive links attached.
 - (d) To replace function lever mechanism, reverse the procedure used to remove it.

SPACING DRUM MECHANISM

- 2.08 To remove spacing drum mechanism (Figure 3), proceed as follows.
- (a) Remove the carriage mechanism (2.02).
 - (b) Remove the TP119653 retaining ring from top of spacing drum and remove drum.
 - (c) From underside of base casting, remove the TP112626 nut and lockwasher from lower end of spacing drum shaft.
 - (d) Lift spacing drum shaft from base casting.
 - (e) To replace spacing drum mechanism, reverse procedure used to remove it.

DISTRIBUTOR TRIP SHAFT MECHANISM

- 2.09 To remove distributor trip shaft mechanism (Figure 3), proceed as follows.

- (a) Remove the distributor mechanism (2. 10).
- (b) Remove the TP119649 retaining ring from post connecting links to each of following cam follower levers: TP180985, TP180820, and TP180821.
- (c) Unhook five springs from the TP180988 spring bracket.
- (d) Loosen the TP180798 screw and TP182264 post, and remove the two TP180972 buffer clamps.
- (e) Remove distributor trip shaft mechanism from base casting.
- (f) To replace distributor trip shaft mechanism, reverse procedure used to remove it.

DISTRIBUTOR MECHANISM

2.10 To remove distributor mechanism (Figure 4), proceed as follows.

- (a) Remove the TP181242 screw and TP180980 brush holder.
- (b) Loosen the three TP180989 distributor disc mounting screws.
- (c) Remove the TP180798 mounting screw and the TP180850 bracket and then remove the clutch trip mechanism.
- (d) Loosen the TP180798 screw and remove the TP180998 clamp.
- (e) Loosen the TP156740 screw and remove the TP182263 bracket.
- (f) Loosen the two screws that mount the TP181023 right bracket.

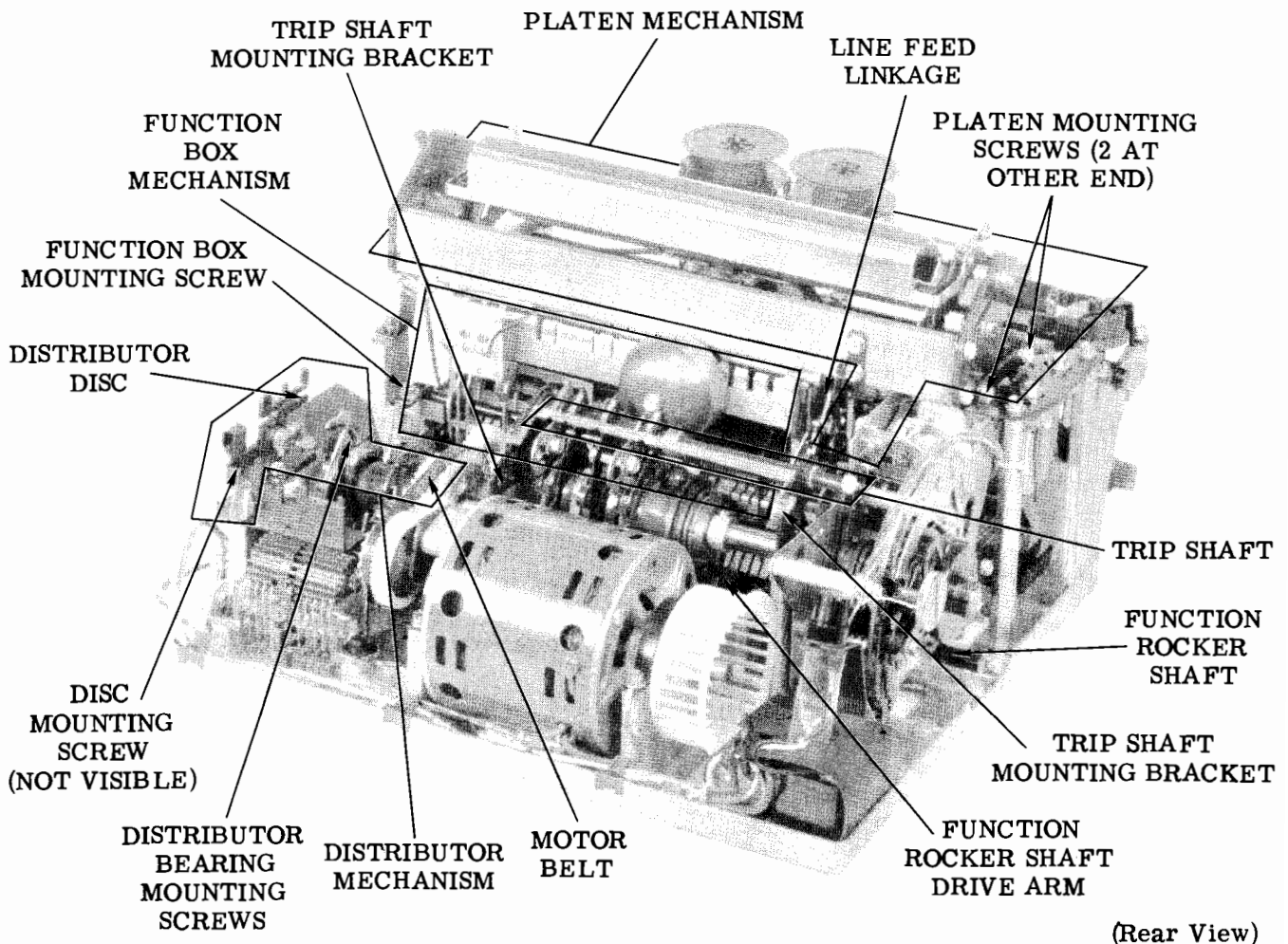

(Rear View)

Figure 4 - Typing Unit

- (g) Remove the belt from the motor.
- (h) Lift the distributor mechanism from the base.
- (i) To replace distributor mechanism, reverse procedure used to remove it. Make sure leads are inserted into proper connections on disc. (See the appropriate wiring diagram.)

FUNCTION ROCKER SHAFT MECHANISM

- 2.11 To remove function rocker shaft mechanism (Figure 3), proceed as follows.
- (a) Remove the trip shaft mechanism (2.16).
 - (b) Remove the form-out mechanism (2.15).
 - (c) Remove the main shaft mechanism (2.18).
 - (d) Remove the TP119651 retaining rings from posts at rear of the TP180769 left and TP180770 right function bail drive link.
 - (e) Loosen the two TP180798 mounting screws and remove the left and right function rocker shaft bearing clamp plates.
 - (f) Lift the function rocker shaft mechanism from the base casting.
 - (g) To replace the function rocker shaft mechanism, reverse the procedure used to remove it.

FUNCTION BOX MECHANISM

- 2.12 To remove function box mechanism (Figures 2, 4, and 7), proceed as follows.
- (a) Remove the carriage mechanism (2.02).
 - (b) Remove the platen mechanism (2.13).
 - (c) Unhook the TP125252 spring (connects to TP180928 codebar reset ball) from the TP180773 plate.
 - (d) Loosen the two TP180798 mounting screws and remove the two TP180796 clamp plates.
 - (e) Lift function box mechanism from base casting.

- (f) To replace function box mechanism, reverse procedure used to remove it. Make sure function levers are in their proper slots and aligned with their respective pawls.

PLATEN MECHANISM

A. Friction Feed

- 2.13 To remove platen mechanism (Figure 4), proceed as follows.
- (a) Remove the TP119651 retaining ring and the TP90615 spring from line feed linkage.
 - (b) Disengage the TP181176 link from the TP181168 bellcrank.
 - (c) Loosen the four TP181242 mounting screws in the two platen side plates.
 - (d) Lift platen mechanism from typing unit.
 - (e) To replace platen mechanism, reverse procedure used to follow it.

B. Sprocket Feed

- 2.14 To remove platen mechanism (Figures 4 and 5), proceed as follows.
- (a) Loosen the TP3598 nut on the TP183351 idler post. Back off the two TP183341 idlers and slip the two TP183379 belts off the sprockets.
 - (b) Loosen the four TP181242 mounting screws in the two platen side plates.
 - (c) Lift platen mechanism from typing unit.
 - (d) To replace platen mechanism, reverse the procedure used to remove it.

FORM-OUT MECHANISM

- 2.15 To remove form-out mechanism (Figures 4 and 5), proceed as follows.
- (a) With the typing unit removed from sub-base, remove the TP181242 mounting screw which secures the TP180980 brush holder.
 - (b) Remove brush holder and brush.

Note: Reader feed contact assembly and certain contact wiring removed.

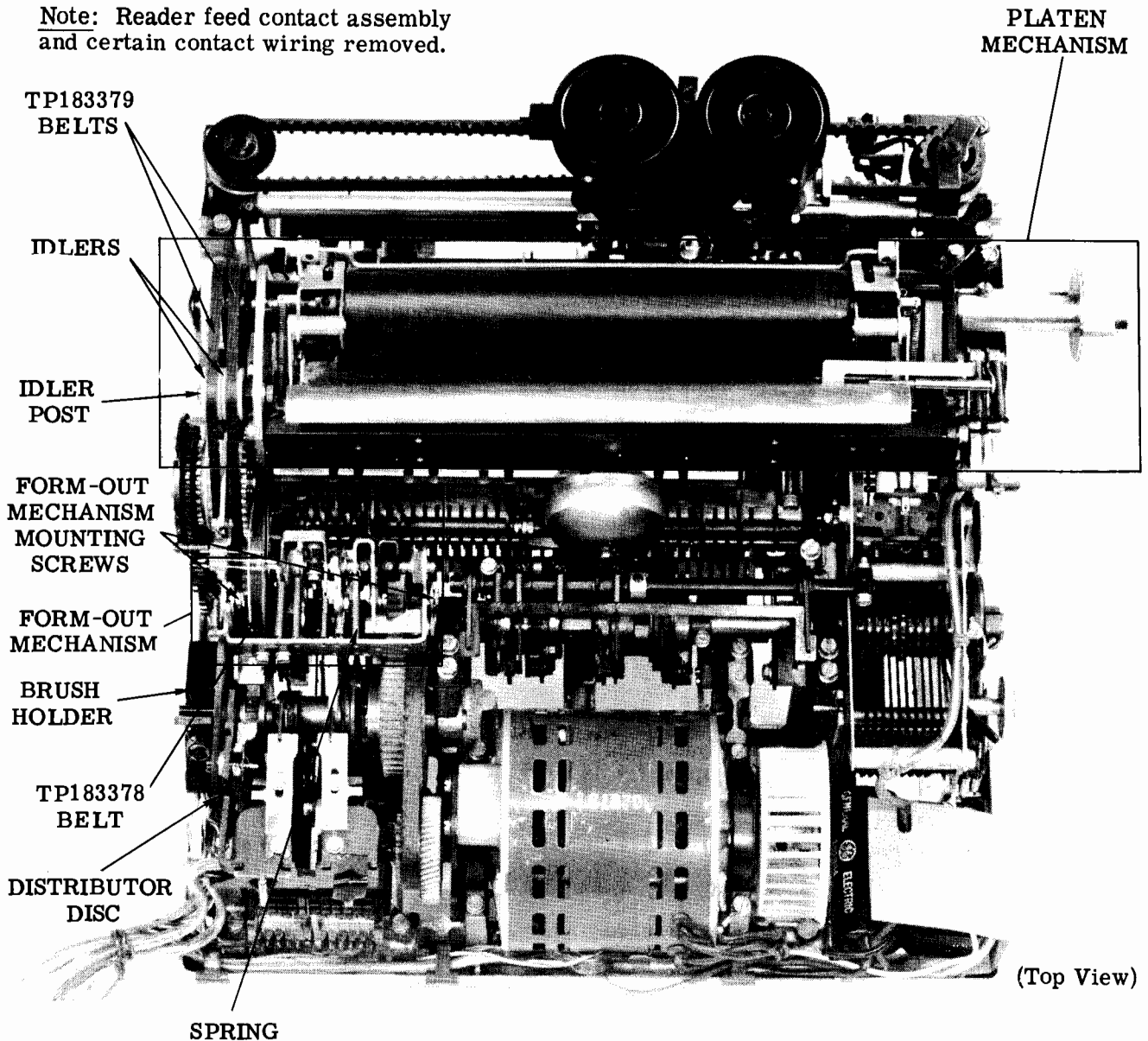

Figure 5 - Typing Unit

Note: On Automatic Send-Receive Teletypewriter Sets, remove the front TP152893 and loosen the rear TP152893 contact bracket mounting screws which secure the tape reader feed magnet contact assembly to the typing unit. Rotate the tape reader feed magnet contact assembly out of the way clockwise, as viewed from the right.

(c) Loosen the two TP180989 distributor disc mounting screws and pull the distributor disc out of the way.

Note: It is not necessary to remove wires from the distributor disc.

(d) Loosen the TP3598 nut on the TP183351 idler post. Back off the two TP183341 idlers.

(e) Slip the two TP183379 belts off the sprockets.

(f) Loosen the three TP151630 form-out mechanism mounting screws.

(g) Slip the TP183378 belt off main shaft sprocket.

(h) Disengage the TP90891 spring from form-out latchlever assembly.

- (i) Gently work form-out mechanism upward and remove it.
- (j) To replace the form-out mechanism, reverse the procedure used to remove it.

Note 1: When tightening the three distributor disc mounting screws, be sure that the longer edges of the TP180676 speed nuts are horizontal with the base casting.

Note 2: The TP186747 downstop bracket (Figure 6) is for factory use only. If the form-out mechanism is removed from the unit as an assembly and the TP186747 downstop bracket is not removed or its mounting screw loosened, the form-out mechanism may be reinstalled in the same unit, using the TP186747 downstop bracket as a stop against the TP183433 bracket. However, if the TP186747 downstop bracket is removed or its mounting screw loosened, it is recommended that the downstop bracket, mounting screw, and flat washer be discarded.

TRIP SHAFT MECHANISM

2. 16 To remove trip shaft mechanism (Figure 4), proceed as follows.

- (a) Loosen the four TP180798 mounting screws, two in the left and two in the right mounting bracket. Push inward on brackets and lift mechanism from base casting.

- (b) To replace trip shaft mechanism, reverse procedure used to remove it.

SELECTOR MECHANISM

2. 17 To remove selector mechanism (Figure 7), proceed as follows.

- (a) Install the TP184098 selector cam removal tool as described on instruction label.
- (b) Remove the TP150040 mounting screw with lockwasher from selector clutch.
- (c) Remove selector clutch from main shaft by pulling clutch to left and rotating it back and forth.
- (d) From underside of base casting, remove the TP180798 mounting screw from bottom of left platen support post. Loosen the TP180798 screw in top of post and remove it and dashpot cylinder.
- (e) Loosen the TP181246 mounting screw in the TP180648 follower arm. Slide arm off trip shaft.
- (f) Loosen the TP180798 mounting screw and remove the TP180682 upstop bracket. Tighten screw to secure the TP181230 retaining plate.
- (g) Remove the three TP180675 mounting screws with the TP180676 speed nuts from selector plate.

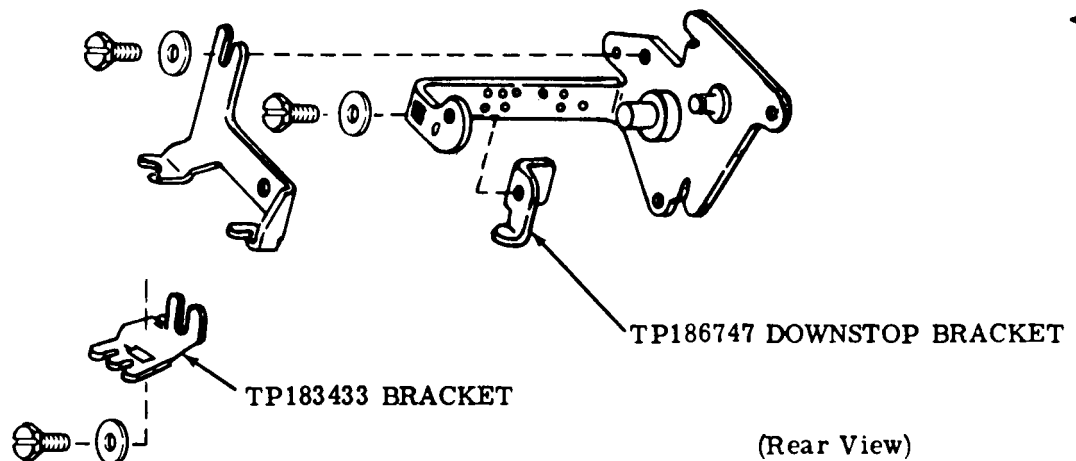
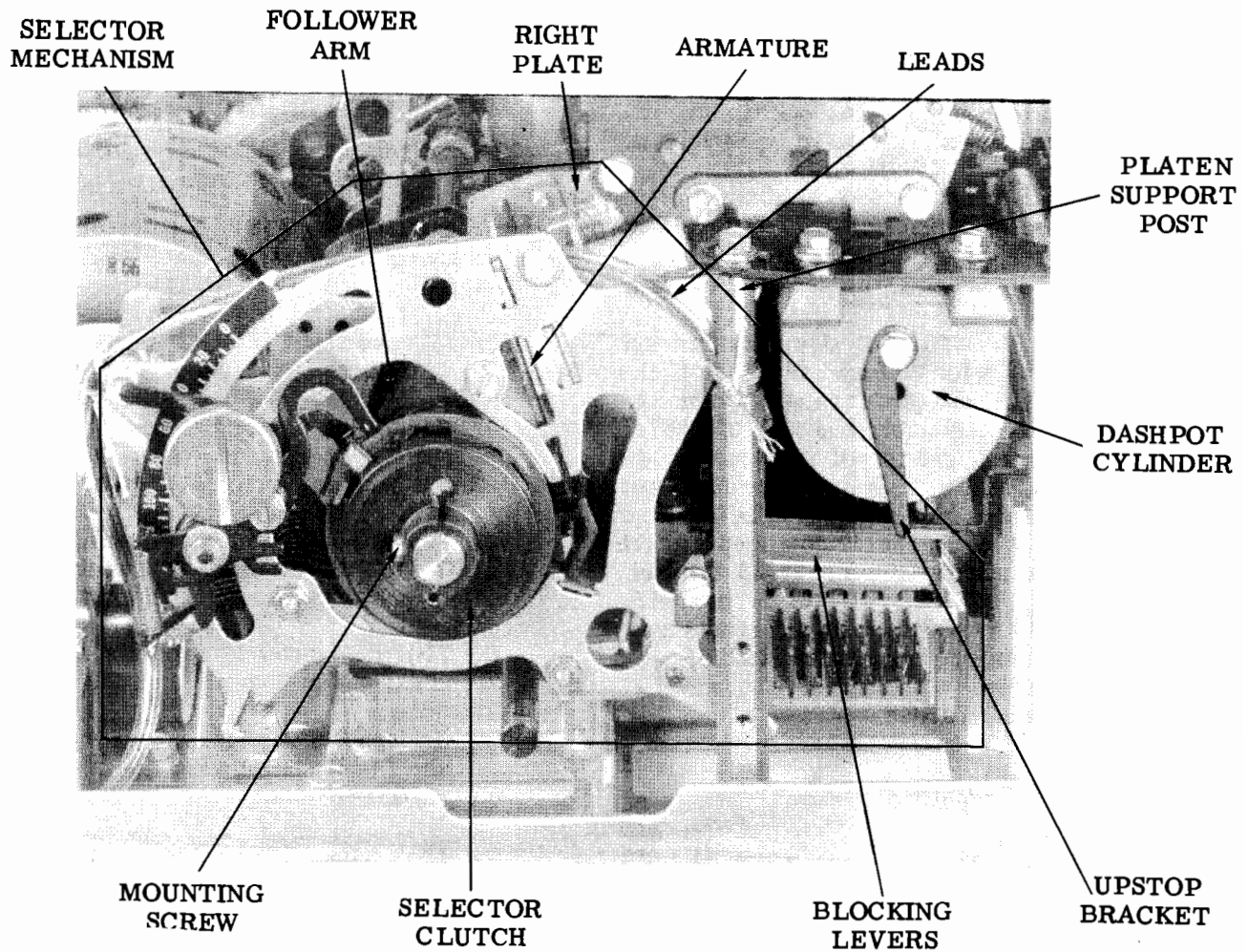

Figure 6 - Downstop Bracket on Form-Out Mechanism



(Left Side View)

Figure 7 - Selector Mechanism

- (h) Remove the two leads from the selector magnet.
- (i) Remove selector mechanism.
- (j) To replace selector mechanism, reverse the procedure used to remove it but with following precautions.
 - (1) Make sure blocking levers are properly seated to guide slots in the front TP180950 codebar tie bracket.
 - (2) To prevent right plate from bending, make sure it is properly fitted around the TP181006 bearing on main shaft.

MAIN SHAFT MECHANISM

- 2.18 To remove main shaft mechanism (Figure 8), proceed as follows.
 - (a) Remove trip shaft mechanism (2.16).
 - (b) Remove selector mechanism (2.17).
 - (c) Remove motor (2.19).
 - (d) Remove form-out mechanism (2.15).
 - (e) Remove the TP3598 nut and flat washer from the TP180546 pivot shaft on carriage drive bail. Disengage front end of the TP181005 drive link from pivot shaft.

- (f) Remove the TP119651 retaining ring from function rocker shaft TP180774 drive arm. Disengage the TP180746 arm on function rocker shaft from drive arm.
- (g) Position main shaft mechanism to the right and lift it from base casting.
- (h) To replace main shaft mechanism, reverse procedure used to remove it. Make sure distributor shaft is properly positioned to left against pressure of brush spring.

MOTOR

2.19 To remove motor (Figure 8), proceed as follows.

- (a) Remove the four TP180798 mounting screws and the two TP181383 motor clamps.
- (b) Disengage motor belt from gear pulley mounted on motor housing.
- (c) Loosen the TP180798 screw in motor start relay.
- (d) Remove motor, motor capacitor, start relay, and associated wiring.
- (e) To replace motor, reverse procedure used to remove it.

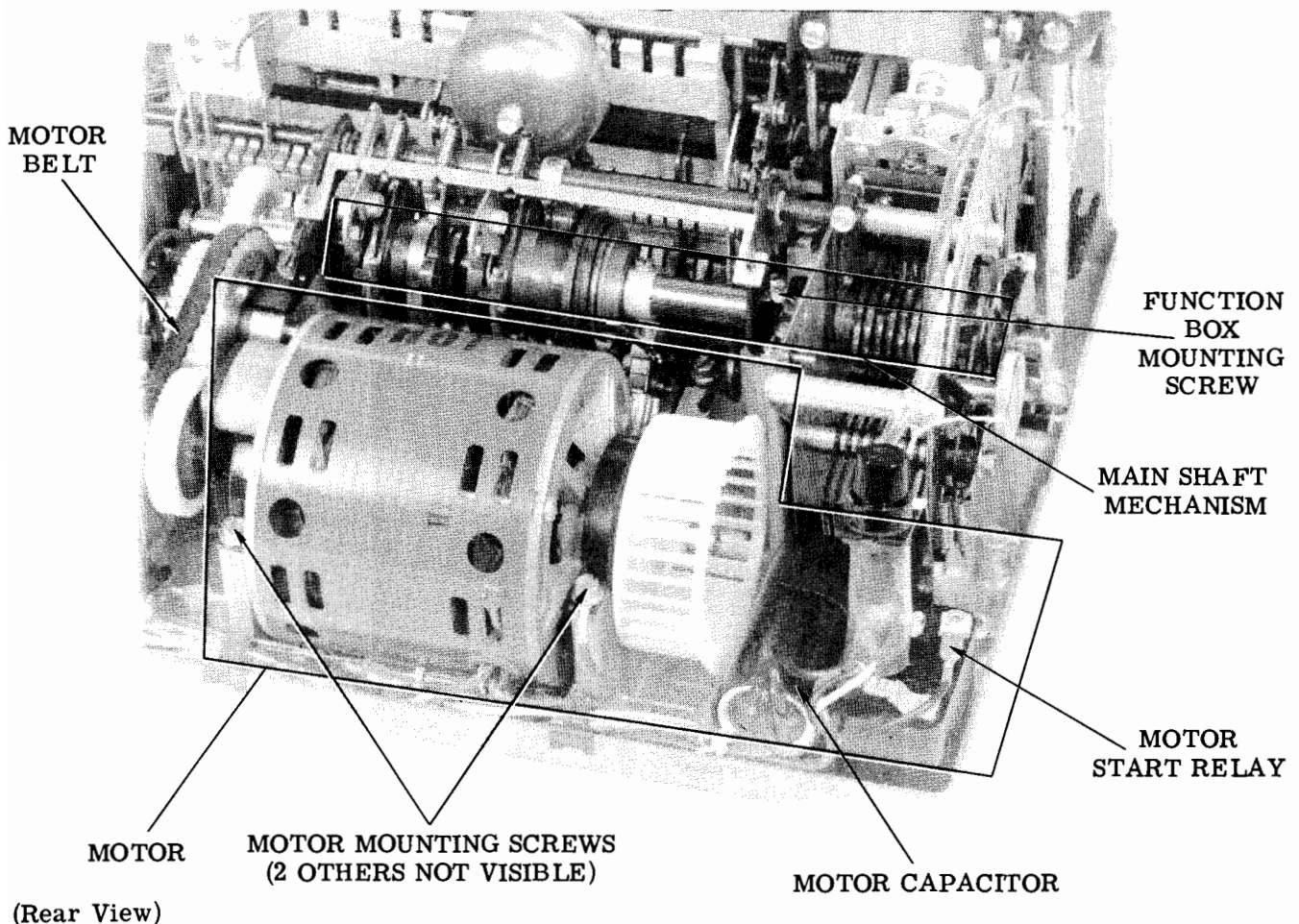

Figure 8 - Typing Unit

33 CALL CONTROL UNIT
 GENERAL DESCRIPTION
 AND OPERATION

CONTENTS	PAGE	2. DESCRIPTION AND OPERATION
1. GENERAL	1	CALL CONTROL UNIT FOR SWITCHED NETWORK SERVICE
2. DESCRIPTION AND OPERATION	1	2.01 The call control unit for Switched Network Service (Figure 1) supplies dc signals to a data set. The data set modulates these signals into tone frequencies which are transmitted over the telephone lines. A data set at the receiving station demodulates the tone frequencies back to dc signals which are then handled by the call control unit for operation of the teletypewriter set. For a better understanding of the call control unit, 2.02 briefly describes the data set.
CALL CONTROL UNIT FOR SWITCHED NETWORK SERVICE	1	
CALL CONTROL UNIT FOR PRIVATE WIRE SERVICE	8	
1. GENERAL		
1.01 This section provides a general description and operation of the 33 call control units. It is reissued to consolidate 33 information. Marginal arrows are not used to indicate changes.		2.02 Start-stop dc signal pulses form essentially a square wave which cannot readily be transmitted over telephone lines. The data set is basically a converter which changes the dc signals from the sending or calling station into frequency-shifted tones for transmission over the telephone network. A marking pulse from a sending station is converted to a 1270-hertz marking signal (F1 mark) and a spacing pulse becomes a 1070-hertz spacing signal (F1 space). The data set at the receiving or called station sends a 2225-hertz marking signal (F2 mark) and a 2025-hertz spacing signal (F2 space). During transmission of a message, the calling station sends a mark and space tones (F1 mark and space) while the called station sends a continuous mark tone (F2 mark). In this way the telephone facilities are operated on a full duplex basis. If the signal received at either station (F1 mark and space at the called station and F2 mark at the calling station) shifts to a space tone for more than one second, or if the received signal is lost for one second, the data set will cause the station to be disconnected. This provides assurance that the connection is maintained for the entire period of message transmission.
1.02 This section describes two call control units which may be considered basic units. They are:		
(1) Call Control Unit for Switched Network Service		
(2) Call Control Unit for Private Wire Service.		
1.03 The call control unit is the electrical link which joins the various components of the set to one another, and the set to the transmission facilities.		2.03 The call control unit used with the data set operates with conventional telephone central offices that have the necessary
1.04 References to left, right, front, or rear consider the call control unit as viewed by the operator.		
1.05 This equipment is intended to be operated in a room environment within the temperature range of 40° F to 110° F. Serious damage to it could result if this range is exceeded. In this connection, particular caution should be exercised in using acoustical or other enclosures.		

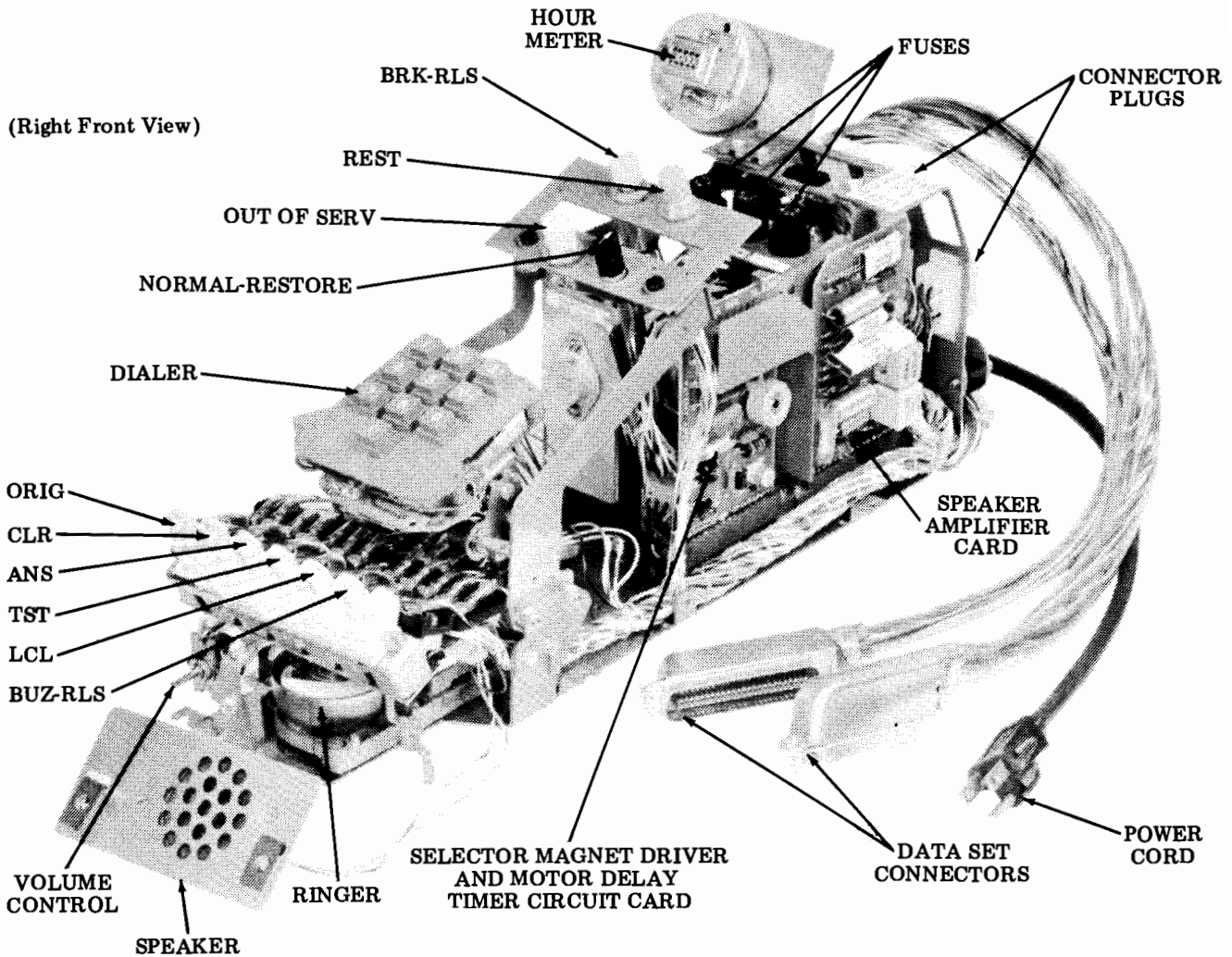
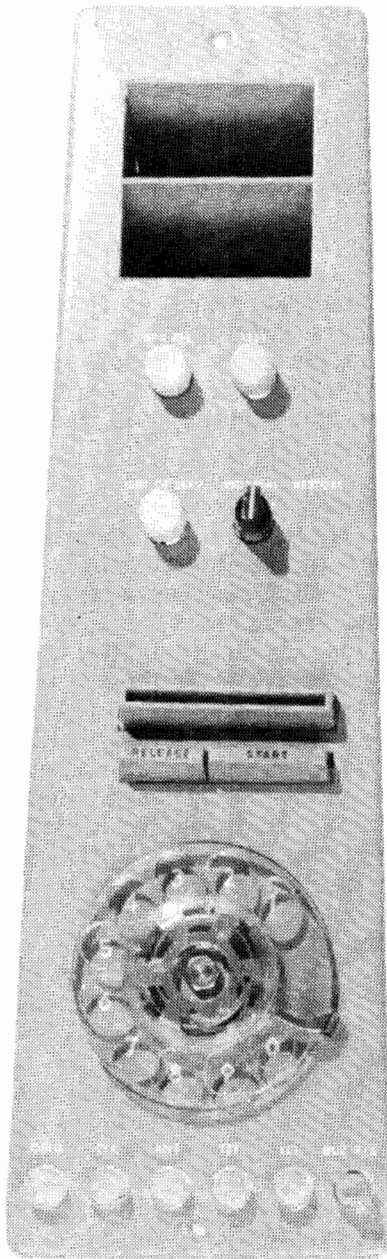

Figure 1 - Call Control Unit for Switched Network Service

routing and accounting facilities. In operation, a call is originated by depressing the ORIG pushbutton (Figure 2). A lamp illuminates the pushbutton, and the dial tone will be heard through a loudspeaker. If the line is busy, a busy signal will be heard and the clear (CLR) pushbutton (non-locking) should be depressed. If the line is not busy, the operator dials the number of desired station. This causes the called station to go into connect condition. If the teletypewriter is manually operated, the called station operator presses the answer (ANS) pushbutton (non-locking). Following a short interval, about 1-1/2 seconds, in which telephone facilities are connected, the called station transmits a mark tone (F2) and receives a mark tone (F1) from the calling station. Receiving the continuous F2 mark tone from the called station for 1 second causes the calling station to go into connect condition,

and its motor is turned on. Likewise, the continuous F1 mark tone from the calling station for 1 second causes the called station to go into connect condition, and its motor is turned on. Either station can now transmit.

2.04 At the end of the message, either station may originate a disconnect by depressing the CLR pushbutton, (Figure 2) at which time each station goes back to its idle condition, ready to receive or originate other calls. For keyboard practice, maintenance purposes, or preparation of copy, the local mode (LCL) pushbutton (locking) is depressed. This turns on the motor and disables automatic answering facilities, if present. In the event of an incoming call during local operation, the call control unit responds to ringing signals and the ANS pushbutton must be operated manually.



ROTARY CARD DIALER

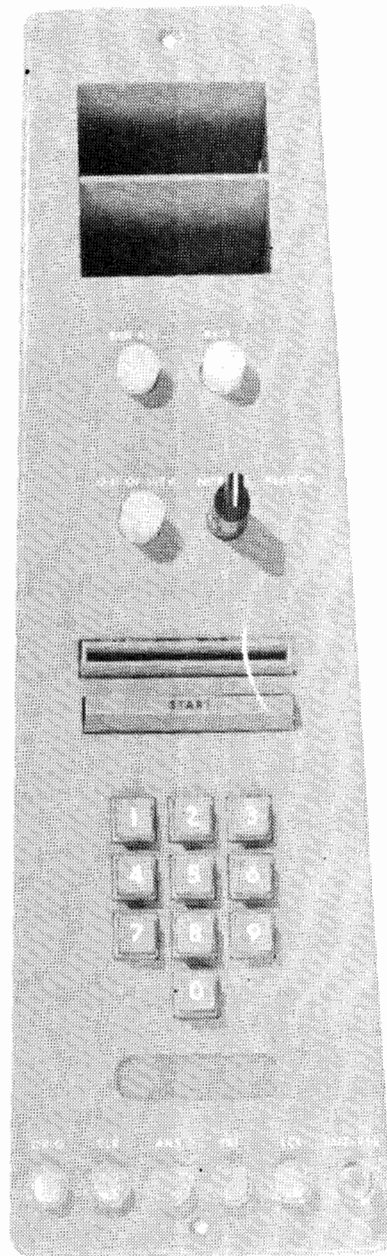

TOUCH-TONE* CARD DIALER

Figure 2 - Call Control Panels

*Registered Service Mark of AT&TCo.

Operation of the test (TST) pushbutton (locking) causes received signals to be retransmitted to the test center for maintenance purposes. A lamp, associated with each pushbutton, illuminates the pushbutton whenever that pushbutton has been operated and the operating condition exists. The ANS lamp is pulsed in response to ringing signals of an incoming call, and lights continuously when the call is answered. The CLR lamp is automatically extinguished 1.5 seconds after the pushbutton has been depressed, and disconnect is completed.

2.05 A steady mark signal blinds the associated teletypewriter during all intervals, except when in the connect condition. This prevents spurious characters from being printed except when due to loss of signals, circuit noise, or deliberate break or space-disconnect signals.

Progress of a Call

2.06 To originate a call, the ORIG pushbutton (Figure 2) is momentarily depressed. This connects the station to the line and lights the ORIG lamp. During the period of time in which connection is being made, the telephone central office makes no time measurements. When the ORIG pushbutton is closed, the call control unit is connected to the telephone line through the data set and an off-hook condition is set up. The amplifier is connected into the circuit so that the dial tone from the central office is heard. The called station is dialed while the amplifier monitors the progress.

2.07 At the called station audible and visible signaling devices are operated. The called station goes off hook and into the connect condition upon operation of the ANS pushbutton circuit, by manual or automatic means, at the distant point. At this time, there is a nonsignaling interval of 1.225 seconds during which accounting and toll recording facilities at the telephone exchange will be cleared. Following the nonsignaling interval, the called station transmits its F2 mark tone and sets its monitoring timer to respond to the F1 mark tone from the calling station. When the continuous F2 mark tone is received at the calling station for a period of 1 second, indicating that a station has answered, it will go into the connect condition and turn on its motor. When the continuous F1 mark tone is received at the called station for an interval of 1 second, it will go into the connect condition. The station may now acknowledge the call either by operator keyboarding, or by automatic answer-back message transmission. The monitoring timers

at both stations are set to respond to reception of a space tone from the distant station. Traffic can now be exchanged from either station on a half-duplex basis.

Disconnecting a Call

2.08 During the time the two stations are connected (traffic interval), either station can initiate a disconnect as follows:

(a) A call is normally terminated by the end-of-transmission (EOT) code combination which provides fast disconnect without introducing hit characters. This is accomplished by the data set in response to EOT contact closures in function boxes of both the sending and receiving teletypewriters.

(b) A call connection can also be cleared manually by momentarily depressing the CLR pushbutton (Figure 2). Operation of the CLR pushbutton at either station will cause transmission of a spacing signal of 1.5-seconds duration, after which the station originating the disconnect will discontinue its tone transmission and go back on hook. The other station, after receiving the spacing signal for 1 second, will automatically transmit its 1.5-second spacing signal and then go on hook. Both stations will then be back in their original idle condition in which calls can be either originated or accepted.

Answering a Call

2.09 To answer a call manually, momentarily depress the ANS pushbutton (Figure 2). This connects the station to the line and lights the ANS lamp. The lamp remains lighted until the answer mode is terminated. Manual answering is necessary only when the automatic answer-back circuit is disabled. The automatic answer-back circuit is disabled by low-paper contacts, data set relay contacts (when in local mode), and the OUT OF SERV. key.

2.10 Call control units equipped with automatic answering facilities will respond to received ringing signals, turning the teletypewriter on at the end of the ringing interval and proceeding through to the connect condition. Automatic message answer-back is a part of this feature. The presence of an operator is required in order to complete disconnect and return the teletypewriter to idle condition. For unattended service, an automatic disconnect timing device

(optional) actuated when a call is answered, will cause the teletypewriter to go through the connect condition, send the 1.5-second spacing tone, and go back on hook if the F1 mark tone is not received within 8 seconds after the called station answered. This is designed to prevent the unattended station from being made busy by (telephone) calls that fail to cause a full connection to be set up. This feature does not affect normal automatic disconnect upon receiving the 1-second spacing tone or loss of tones due to a dropoff.

Local Mode

2.11 The local mode (LCL) provides off-line operation of the teletypewriter. The operator selects the local mode by depressing the LCL pushbutton (Figure 2). This lights the LCL lamp and operates the motor control relay (MCR) to energize the motor. The data set connects the sending circuit to the receiving circuit and enables the keyboard and answer-back to transmit. In this condition the teletypewriter can be used for preparing copy, for operator practice, or for maintenance purposes. If an incoming signal is received during this time, ringing signals are received and manual operation of the ANS pushbutton is required in order to receive the message. If the teletypewriter is in a terminal hunting group, the operator must turn the out-of-service (OUT-OF-SERV.) knob to the RESTORE position momentarily and then to NORMAL.

OUT OF SERV. Switch

2.12 The OUT OF SERV. switch (Figure 2) prevents the automatic answering of incoming calls. In its NORMAL position (arrow on knob upright), it has no effect or function; in the OUT OF SERV. position (knob rotated counterclockwise and detented) it sets the following conditions:

- (a) A contact is closed that causes the OUT OF SERV. lamp to light.
- (b) A contact is closed that shorts the ringer coils. This makes the ringer inoperative. As an option the contact can be located to shunt both the ringer and series capacitor (ie, the telephone line). This makes the station appear to be in an off-hook condition or busy to the central office.
- (c) A contact is opened that breaks the automatic answer circuit to the answer relay. This prevents the relay from operating

in response to the ring-up relay and thus the teletypewriter will not answer.

2.13 For stations that are not in terminal hunting groups, the operator may return the teletypewriter to service by turning the OUT OF SERV. knob to the NORMAL position. For terminal hunting stations, however, the operator must turn the knob to the RESTORE position and hold it until a dial tone is heard. In this position:

- (a) A contact is closed that shorts the tip to ring (off-hook condition). This condition is detected by the central office which then releases the teletypewriter from lockout and applies the dial tone.
- (b) A contact is closed that completes a path from the speaker amplifier to ground. This permits the amplifier to pass the line signals (dial tone).

The OUT OF SERV. switch is then restored to NORMAL.

Low-Paper Alarm

2.14 A low-paper alarm is provided in the teletypewriter. When a low-paper condition occurs, make contacts in the low-paper switch provide ground to the low-paper buzzer, permitting it to operate. Depressing the buzzer-release (BUZ-RLS) pushbutton (locking) in the call control unit (Figure 2) silences the buzzer and causes the BUZ-RLS lamp to light. Attempting to release the pushbutton without replenishing the paper supply will result in the buzzer operating. When the paper has been replenished, the teletypewriter is returned to normal by releasing the BUZ-RLS pushbutton.

2.15 Break contacts on the low-paper switch disable the automatic answer-back circuit. The operator can override this condition by answering manually. If the low-paper alarm occurs during a call, the operator has the option of completing the call before changing the paper, or interrupting the call. To interrupt the call, the operator stops transmission by depressing the keyboard BREAK key, and then depressing the BRK-RLS pushbutton to notify the distant station of the problem. The connection is cleared by simultaneously operating the control (CTRL) and EOT keys on the keyboard. Turning the OUT OF SERV. knob to the detent position insures that the teletypewriter will not automatically answer a call while paper is being replenished.

2.16 To restore the teletypewriter to service after the paper has been inserted, depress the CLR pushbutton and return the OUT OF SERV. knob (Figure 2) to its NORMAL position. (For teletypewriters in terminal hunting groups, turn the knob to its RESTORE position and hold it there. When dial tone is heard, release the knob.) The teletypewriter is now in a normal idle operating position.

Restrain Lamp

2.17 This high intensity restrain (REST) lamp (Figure 2) lights when a restraining signal is received from an 8-level to a 5-level converter used in transmission to 5-level TWX stations on the DDD switching plan. The lamp remains lighted until the restraining signal is removed. The purpose of this feature is to limit the sending speed from 8-level teletypewriter transmitting at 100 wpm to 5-level teletypewriters receiving at 60 wpm.

Test Mode

2.18 If the TST pushbutton (Figure 2) is operated while the teletypewriter is connected to a test center, the message sent by the test center will be recorded on the teletypewriter and turned around and sent back for analysis. This is accomplished by connecting the teletypewriter to the data set through a set of transfer contacts and a break contact to ground. This type of operation can be terminated by momentarily operating any of the nonlocking pushbuttons which will then release the TST locking pushbutton.

Signal Generation

2.19 The teletypewriter can send by operating the keyboard, answer-back mechanism, or BREAK key (Figure 2). The keyboard signal generator contacts and answer-back contacts are in parallel with the signal generator (distributor) which is, in turn, connected to the data set. The BREAK key connects to the data set via separate leads.

Dialers

2.20 Pulsing Rotary Dialer: For rotary dialer applications, a pulsing contact of the rotary dialer is inserted into the telephone line. The rotary dialer (Figure 2) is equipped with a normally closed pulsing contact and a normally opened off-normal contact. The pulsing contact is inserted into the telephone line when the station

originates a call. When answering the call, a short circuit is applied across the pulsing contact. The off-normal contact is placed across the output of the amplifier and silences the speaker whenever the dialing disc is moved.

2.21 Pulsing Card Dialer (40A Dialer): The 40A dialer operates on direct current furnished from the central office. To use the card dialer, the ORIG pushbutton is depressed. After a dial tone has been received, a card with the telephone number punched in it is firmly inserted in the slot. This operation winds a spring which later pushes the card out of the slot as dialing proceeds.

2.22 The card dialer is started by momentarily depressing the START bar. This operates the card dialer start contact and establishes a path from the ring side to the tip side of the telephone line. Sending of the dial pulse means interruptions of the current in the telephone line.

2.23 A scanning drum makes sixteen revolutions: ten for transmitting the digits and six for interdigital time. At the completion of the revolutions, an escapement is tripped which permits the next row of holes on the card to be placed in position for sensing.

2.24 This sequence is repeated at each row as the card advances out of the card dialer. If no "stop" code is punched in the card, the card dialer will continue to advance the card (even if no number code is punched) until the card is released. If the "stop" code is sensed, the card dialer stop contacts operate. The card can be released by operating the RELEASE bar. No attempt should be made to release the card by reoperating the START bar, as this will trigger the card dialer mechanism and place a short circuit across the output of the data set. This shunt will prevent the station from receiving or sending until the card is disengaged. If this condition persists, the data set will disconnect.

2.25 Pulsing Card Dialer (41A Dialer): In locations with 60-hertz ac power, the 41A card dialer is used. In this dialer the power to operate the commutator disc is derived from a synchronous motor powered by the 14 v ac source in the teletypewriter. The power to advance the card in the dialer is derived from a spring wound by inserting the card in the slot. The switching functions and the motor control are independent of the signal path. These features result in a superior performance as compared with the 40A dialer.

2.26 To operate the dialer, the card is inserted and the START bar is momentarily operated. The commutator disc begins rotating, and the dial pulses are sent to the line.

2.27 When all the punched codes are sent, the disc stops. A mechanical linkage then permits the spring, wound by inserting the card, to advance the card for the next digit to be read and dialed. As the "stop" code is read, the dialing stops. The card can then (as also at any other time) be released by operating the RELEASE bar.

2.28 TOUCH-TONE Dialer: For multifrequency (MF) dialing applications, the dialing frequencies generated by the TOUCH-TONE dialer are fed through the loudspeaker amplifier and into the telephone line via the sending amplifier in the data set. As the station connects, the output of the TOUCH-TONE dialer is disconnected from the data set so that there is no hazard connected with improper operation of the TOUCH-TONE dialer at that time.

2.29 The TOUCH-TONE MF signal generated is a one-transistor oscillator generating two frequencies any time a single pushbutton is operated. Seven frequencies are provided, with each dial digit corresponding to two frequencies according to the table below:

TOUCH-TONE

Frequencies

cps →	1209	1336	1477	
↓				
697	1	2	3	Dial Digits
770	4	5	6	
851	7	8	9	
941		10		

2.30 The frequencies above 1000 hertz are generated at a somewhat higher level to compensate for greater line loss at those frequencies. There is also a variation or amplitude for various digits.

2.31 TOUCH-TONE and Card Dialer (Figure 2): To use the automatic card dialer, the ORIG pushbutton is depressed. After the dial tone has been received, a punched card is inserted into the slot and pushed down. The START bar is

then momentarily operated. The card dialer proceeds with dialing under power of a spring motor wound by insertion of the card. When a "stop" code is read, the dialing stops. The card should then be released by reoperating the START bar.

2.32 The sensing contacts in the card dialer are in parallel with the frequency-determining contacts in the associated TOUCH-TONE dialer. As the card advances out of the slot, the sensing contacts sense the holes punched in the card and thus determine the proper frequencies to be transmitted. This occurs for every row on the card.

2.33 Since the card advances out of the slot very rapidly, there is no need for a separate RELEASE bar. When the station connects, relay contacts in the data set disconnect the MF signal input and remove any hazard connected with false operation of the TOUCH-TONE dialer.

Fuse Protection

2.34 Three fuses protect the components in the call control unit from accidental shorts or overloads. They are the selector magnet driver fuse, the motor delay timer fuse, and the ac line fuse.

Electrical Interconnections

2.35 A number of nylon plugs and a terminal strip located at the rear serve to interconnect the set components to the call control unit. A six foot power cord connects the call control unit to the ac power source.

Circuits

2.36 Selector Magnet Driver Circuits: The data set supplies a 20-mA dc signal to the selector magnet driver associated with the teletypewriter. The selector magnet driver amplifies the signal to 500 mA to operate the selector on the teletypewriter. The selector magnet driver is a two-stage triggering regenerative amplifier (or flip-flop) capable of switching high output currents of 0.500 ampere at very closely controlled input current levels. The output of the selector magnet driver is automatically regulated and is essentially independent of normal variations in power supply voltage, and of selector-magnet and current-limiting resistance values.

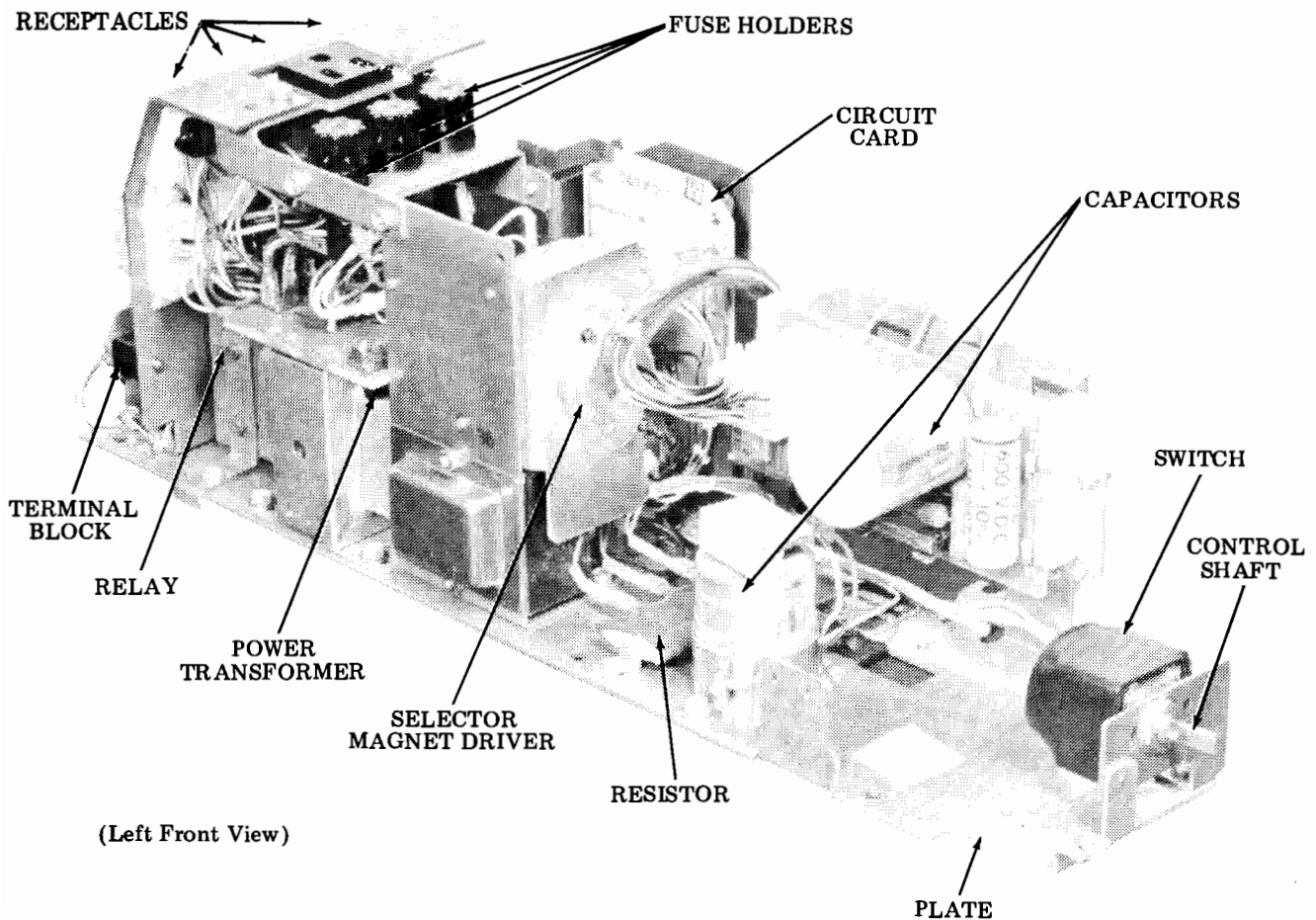

Figure 3 - Typical Call Control Unit for Private Wire Service

2.37 Speaker Amplifier Circuit: The speaker amplifier is powered only after the ORIG key is operated and is quieted when the station connects. It has two inputs, one from the telephone line via the buffer amplifier in the data set limiter and the other from the multifrequency (MF) tone dialer. Three outputs are provided: (1) into the speaker or optional hand-held receiver, (2) into the telephone line through the sending amplifier in the data set, and (3) an auxiliary output into the data set. The line-to-speaker connection permits monitoring of supervisory signals when originating a call. The TOUCH-TONE dial-to-line and TOUCH-TONE dial-to-speaker connection provides for amplification of the outgoing MF dialing signals and for monitoring them during outpulsing. The line-to-second-output connection is provided for the dial tone detector (when furnished). The various connections mentioned are established by switching in the data set and by the common switch in the TOUCH-TONE dialer.

2.38 Technical Data

Dimensions (Approximate)

Width 5 inches
 Length17 inches
 Height 6 inches

Input 115 v ac \pm 10%, 60 Hz
 Environmental conditions 40° F to 110° F ambient temperature

CALL CONTROL UNIT FOR PRIVATE WIRE SERVICE, (Figure 3)

2.39 Power for the motor, selector magnet driver, local power supply, and tape reader power pack, is supplied from fused 115 volt ac, 50 to 60 hertz power. Direct current of either 0.020 or 0.060 ampere is required for the signal line(s) and for operation in the local mode. The dc power for the signal line(s) is supplied by

external facilities, while local dc current for operation in the local mode is furnished through the operation of the local power supply circuit in the call control unit. At the rear of the call control unit is a terminal strip which provides the point of entry for the ac power and signal line(s) into the teletypewriter set.

Note: Normally the tape reader power pack comes from the factory installed in the call control unit; optionally the power pack may be mounted in the stand. See Section 574-100-201TC.

2.40 A 3-position rotary power switch is the only manual control on the call control unit. Its three positions are: OFF, LOCAL, and LINE.

Fuse Protection

2.41 Two fuses protect the components in the call control unit from accidental shorts and overloads. They are the selector magnet driver fuse and the ac power line fuse.

Electrical Interconnections

2.42 Connector plugs at the rear of the call control unit serve to interconnect the set components to the call control unit. A terminal strip, also located at the rear, serves to connect the ac power to the call control unit and offers a convenient terminating area for other accessories and external connections.

Line Mode

2.43 When the switch is in the LINE position, the teletypewriter is placed in the external signal line loop for communication with other teletypewriters. The external signal line

loop is united with the selector magnet driver. With dc power on the signal lines, transmission from the keyboard or tape reader will cause the typing distributor to send start-stop signals to other teletypewriters in the external signal loop. Also, the local teletypewriter is able to receive, through the typing unit selector, the start-stop signals transmitted from other teletypewriters in the signal line loop.

Local Mode

2.44 When the switch is in the LOCAL position, (1) the local battery is supplied to the selector magnet driver and the send circuit, (2) the external signal line loop is divorced from the selector magnet driver, and (3) the external signal line loop is shunted so that other teletypewriters in that loop can communicate without being affected by the operation of the local teletypewriter.

Off Mode

2.45 When the switch is in the OFF position, the signal line is diverted around the local teletypewriter. Other teletypewriters can communicate in the signal loop without interference. All power in the call control unit, except the ac power to the selector magnet driver, is off.

2.46 Technical Data

Dimensions (Approximate)

- Length 15 inches
- Width 4-1/2 inches
- Height 6 inches

- Input 115 v ac, 50-60 Hz
- Environmental conditions 40° F to 110° F ambient temperature

UCC39 CALL CONTROL UNIT
 GENERAL INFORMATION

CONTENTS	PAGE	CONTENTS	PAGE
1. GENERAL	1	4. INSTALLATION	18
2. OPERATION	3	INSTALLING THE CALL CONTROL UNIT	18
ORIGINATING A CALL	4	A. Assembling the UCC39 Into a 33 RO, KSR, or ASR	18
ANSWERING A CALL (MANUAL ANSWER)	4	B. Assembling the UCC39 Into a 35 RO or KSR	19
ANSWERING A CALL (AUTO ANSWER)	4	C. Assembling the UCC39 Into a 35 ASR	20
DISCONNECTING A CALL	4	CONNECTING THE INTERFACE CABLE	22
FULL DUPLEX OPERATION	4	OPTIONS	22
ECHO OPERATION	4	SIGNAL LEVEL ADJUSTMENT	22
LOCAL OPERATION	5	1. GENERAL	
OPTIONS	5	1.01 This section provides general informa- tion on the UCC39 call control unit. This unit permits local or on-line operation of a 33 or 35 teletypewriter and features a data modem (moe' - dem) which permits operation on the direct distance dialing network without the need for a data set.	
3. CIRCUIT DESCRIPTIONS	5	1.02 As shown in Figure 1, the basic call control unit consists of a circuit card assembly, a six-button keyswitch assembly, and a power supply, all mounted on a baseplate to form a self-contained unit. The complete unit mounts in the upper right side of the 33 teletypewriter. In a 35 teletypewriter the unit may be mounted in the upper right side (RO or KSR) or in the pedestal (ASR). In all installations it is connected to the adjunct units by cables.	
CONTROL LOGIC CARD (TP322491)	6	1.03 The pushbutton switches permit mode switching, and the lamps in the push- buttons indicate the operating modes. An alarm lamp provides an indication of low paper (friction feed sets) or paper out (sprocket feed sets).	
A. Send Data Circuits	6	1.04 Two circuit cards provide the control and signal conversion required for operation of the terminal. The TP322491 logic	
B. Selector Magnet Driver	7		
C. Originate/Answer Mode Control	7		
D. On-Line Control	8		
E. Motor Control	9		
F. Carrier Control, Originate/ Answer Lamps	9		
G. Answer-back Control	11		
H. Reset Circuits	11		
MODEM CARD (TP322490)	11		
A. Tone Input/Output Circuits	13		
B. Demodulator Amplifier/Limiter and Discriminator Driver	14		
C. Discriminator Circuits	14		
D. Carrier Detect Circuit	15		
E. Modulator Circuit	15		
POWER SUPPLY (TP188865)	17		

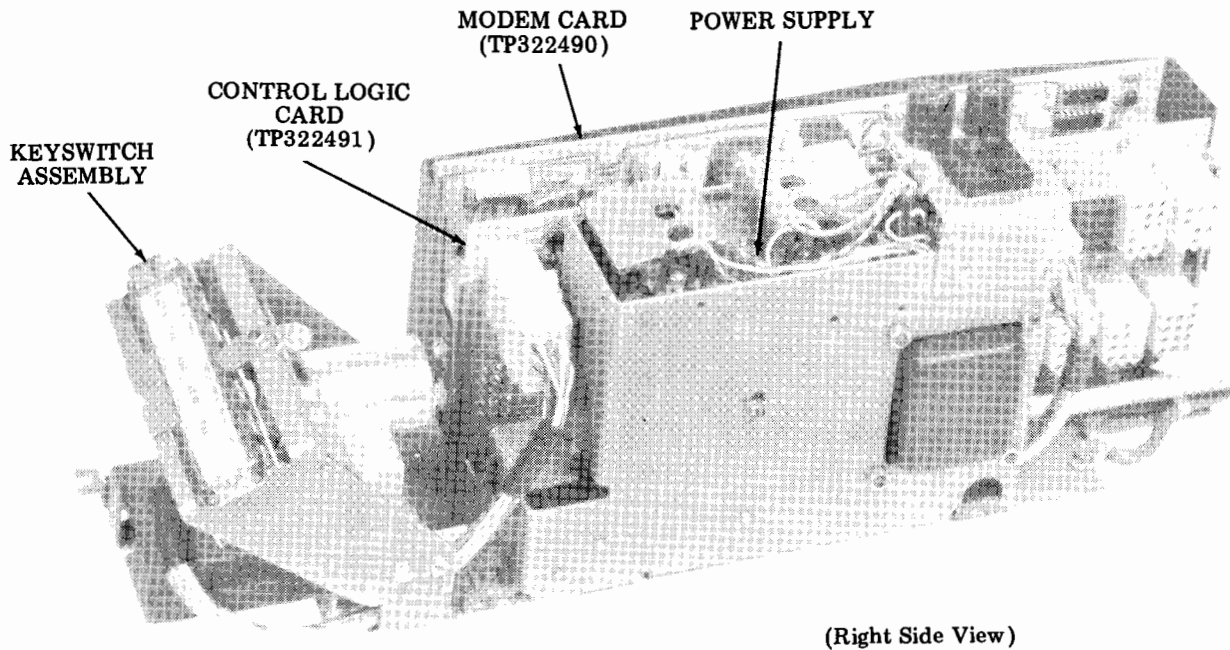

Figure 1 - UCC39 Call Control Unit

card controls the operating modes. The TP322490 modem (modulator/demodulator) card provides analog/digital conversions. The modulator part of this card converts the start-stop digital signals of the teletypewriter distributor to Frequency Shift Keyed (FSK) analog signals suitable for transmission on telephone lines. The demodulator converts FSK signals received from a remote terminal to dc signals suitable for the selector of the teletypewriter.

1.05 The power supply operates from the 115 volt, 50/60 Hz ac line. It provides fused ac and dc operating voltages for the call control unit and adjunct equipment.

1.06 When used with a Data Access Arrangement (DAA) and telephone handset, the call control unit provides all functions required to originate or answer calls and is completely compatible with 100 Series data sets (or equivalent). The system is shown in block diagram form in Figure 2. With a manual DAA (1000A or equivalent) the unit serves as a manual originate, manual answer data set. With an automatic DAA (1001B, 1001D, or equivalent) it serves as a manual originate, auto answer data set. The telephone is a 502A or equivalent with an exclusion key.

1.07 Basic operation of the call control unit is half-duplex. However, it features a full duplex mode selectable by the operator. An echoplex mode is also selectable, whereby the unit returns or "echoes" signals to the remote transmitter so the remote operator can check the accuracy of the data exchange.

1.08 The following operating characteristics apply to the UCC39 call control unit:

Input Voltage

115 volts ac, 50/60 Hz, $\pm 0.75\%$

Input Current

0.5 amp (nominal) to satisfy 6 v and 24 v load requirements (1 amp each); 2.50 amp (max) to satisfy 33 or 35 motor, plus 0.85 amp (max) for convenience receptacle

Time Base

Asynchronous, start-stop serial code

Modem FSK Carrier Frequencies

Originate

Transmit (F1) — 1070 Hz (space)
1270 Hz (mark)
Receive (F2) — 2025 Hz (space)
2225 Hz (mark)

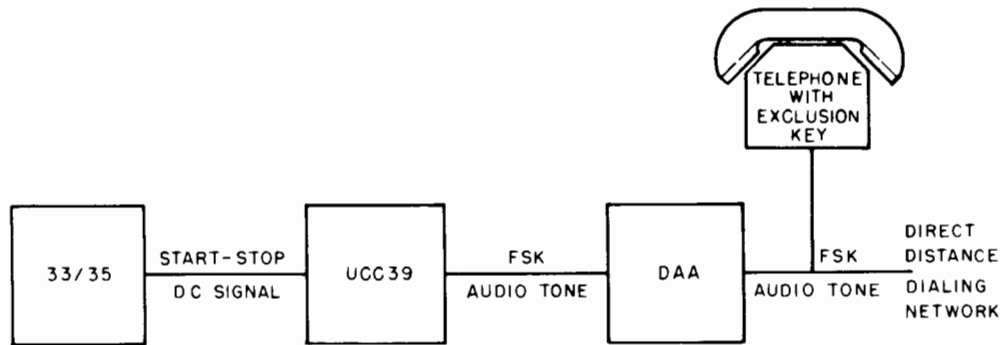

Figure 2 - Interconnection of Call Control Unit and Adjunct Units to Permit Operation on Direct Distance Dialing Network

Answer

Transmit (F2) — 2025 Hz (space)
2225 Hz (mark)
Receive (F1) — 1070 Hz (space)
1270 Hz (mark)

(All frequencies ± 1.5 Hz)

Power Supply Outputs

+24 v dc, -24 v dc, +6 v dc, 6 v ac, and 500 ma selector magnet drive

Relative Humidity

To 95%

Altitude

Sea level to 10,000 feet (operating)
Sea level to 50,000 feet (shipping)

Ambient Temperature

+40°F to +110°F (operating)
-40°F to +150°F (storage)

CAUTION: THIS EQUIPMENT IS INTENDED TO BE OPERATED WITHIN THE TEMPERATURE RANGE OF +40°F to +110°F. SERIOUS DAMAGE CAN RESULT IF THIS RANGE IS EXCEEDED. PARTICULAR CAUTION SHOULD BE EXERCISED IN USING ACOUSTICAL OR OTHER ENCLOSURES.

2. OPERATION

2.01 The operator activates the call control unit by means of the six pushbuttons illustrated in Figure 3. The functions of the pushbuttons and the indicator lamps within the buttons are as follows:

CLEAR/ALARM — A momentary pushbutton which lights (red) when depressed and clears the set of its operating mode. The lamp also lights to indicate a paper alarm condition.

LOCAL — A locking pushbutton which lights (green) when depressed and places the set in the local mode.

ORIG — A momentary pushbutton which lights (white) when depressed and conditions the set for on-line operation. The operator then establishes a connection with the remote station to exchange data.

ANS — A momentary pushbutton which lights (white) when depressed, and places the set in the receive mode after a connection is made with a remote station.

ECHO — A locking pushbutton which lights (white) when depressed and conditions the terminal for echoplex operation. Received signals are returned to the remote station to permit a check of transmission accuracy.

FDX — A push on, push off pushbutton which lights (white) when depressed and conditions the set for simultaneous transmission and reception of data (full duplex).

2.02 The UCC39 call control unit can be interfaced directly to a private telephone line or through a DAA to the direct distance dialing network. A manual DAA (1000A or equivalent) permits manual originate, manual answer service. An automatic DAA (1001B, 1001D or equivalent) permits manual originate, auto answer service. Calls are placed or answered through a telephone (502A or equivalent) adjunct to the DAA.

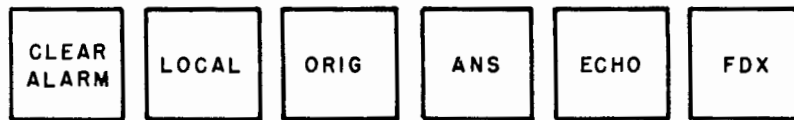

Figure 3 - Pushbutton Switches and Indicator Lamps

ORIGINATING A CALL

2.03 To originate a call, the operator lifts the telephone handset and dials the remote terminal. With an automatic DAA, the exclusion key must be lifted before dialing. If the remote terminal has auto answer capability, its f2 carrier will be heard in the handset. If the remote terminal is arranged for manual answer, it will not send the f2 carrier until the remote operator goes into the answer mode. When the f2 carrier is heard, the local operator depresses the ORIG button and goes on-line by hanging up the handset (auto DAA) or lifting the exclusion key (manual DAA). The teletypewriter motor turns on and the ORIG lamp lights. After a 400 ms delay (to disable the Telephone Company echo suppressors), the local terminal turns on its f1 carrier to complete the data connection.

ANSWERING A CALL (MANUAL ANSWER)

2.04 An incoming call causes ringing at the local terminal. The operator answers the call and agrees to go into the data mode, depresses the ANS button, and goes on-line by lifting the exclusion key on the telephone. The teletypewriter motor turns on and the local terminal sends its f2 carrier to the remote terminal. The remote terminal completes the data link by turning on its f1 carrier. Upon receipt of f1, the ANS lamp lights. If the local terminal is equipped for auto answer-back, it transmits its answer-back to the remote terminal.

ANSWERING A CALL (AUTO ANSWER)

2.05 The call control unit can provide auto answer operation when used with an auto answer DAA. With the call control unit in the clear mode, an incoming call turns on the teletypewriter motor and initiates the answer mode. The local terminal sends its f2 carrier to the remote terminal, which responds by turning on its f1 carrier to the local terminal. This completes the data link and lights the ANS lamp. If equipped for auto answer-back, the local terminal sends its answer-back to the remote terminal.

2.06 If an auto answer terminal is in the local mode, the auto answer operation is inhibited but an incoming call causes the ANS lamp to flash. The operator can then go into the answer mode by depressing the ANS button, or can remain in the local mode and answer the call by lifting the handset. If the ANS button is depressed, the local button unlocks and its lamp goes out, and the f2 carrier is sent to the remote terminal. The remote terminal responds with its f1 carrier. The ANS lamp lights, and if equipped for auto answer-back, the local terminal sends its answer-back to the remote terminal.

DISCONNECTING A CALL

2.07 Disconnect in the originate or answer mode occurs upon receipt of an EOT character, upon loss of carrier, or upon depression of the CLEAR button. With a manual DAA, the handset must be placed on-hook to complete the disconnect.

FULL DUPLEX OPERATION

2.08 The call control unit provides simultaneous transmission and reception of data (full duplex operation) when the FDX button is depressed in the originate or answer mode. The FDX lamp lights when the button is depressed. Received data is printed out by the teletypewriter, but transmitted data does not provide a printout. To restore half-duplex operation the FDX button is depressed a second time.

Note: Full duplex operation is not possible with an RO unit.

ECHO OPERATION

2.09 When the ECHO button is depressed, incoming data is returned to the remote sender for verification of accuracy. The sender must be operating full duplex to receive the echo. The ECHO button is a locking pushbutton which lights when depressed. To release the button, the operator depresses the CLEAR or LOCAL button.

LOCAL OPERATION

2.10 Local operation permits preparation of printed copy (33 or 35 KSR or ASR) and punched tape (33 or 35 ASR) without on-line operation. When the LOCAL button is depressed, the button locks and the lamp lights (green). All local functions can be performed, but on-line transmission or reception is inhibited. The operator can place or answer calls via the DAA, but must manually initiate on-line operation by depressing the ORIG or ANS button. This unlocks the LOCAL button and enables on-line operation.

OPTIONS

2.11 Option screws on the TP322491 logic card permit the following features in the operation of the call control unit:

Send Inhibit — When this option screw is installed, it prevents the keyboard (KSR or ASR) and reader (ASR) from transmitting to the remote terminal in the echo mode. With the screw omitted, the keyboard and reader transmit in the echo mode.

Paper Alarm — When the option screw is installed, a low paper (friction feed) or paper out (sprocket feed) condition, lights the ALARM lamp (red) but has no effect on the send and receive functions of the terminal. With the screw omitted, a paper alarm lights the lamp and also prevents call connection with a remote station. On TP322491 cards previous to Issue 4, disconnect also occurs on existing calls.

Answer-back Trip — With this screw installed, the answer-back is tripped automatically when the answer mode has been established. With the screw omitted, the answer-back is not automatically sent upon call connection.

3. CIRCUIT DESCRIPTIONS

3.01 The circuitry of the UCC39 call control unit is contained on two circuit cards: the TP322491 logic card and TP322490 modem card. Operating voltages and currents are provided by the TP188865 power supply. The functions of the circuits are outlined in the following circuit descriptions. Complete schematic diagrams and detailed circuit descriptions are contained in Wiring Diagram Package WDP0341.

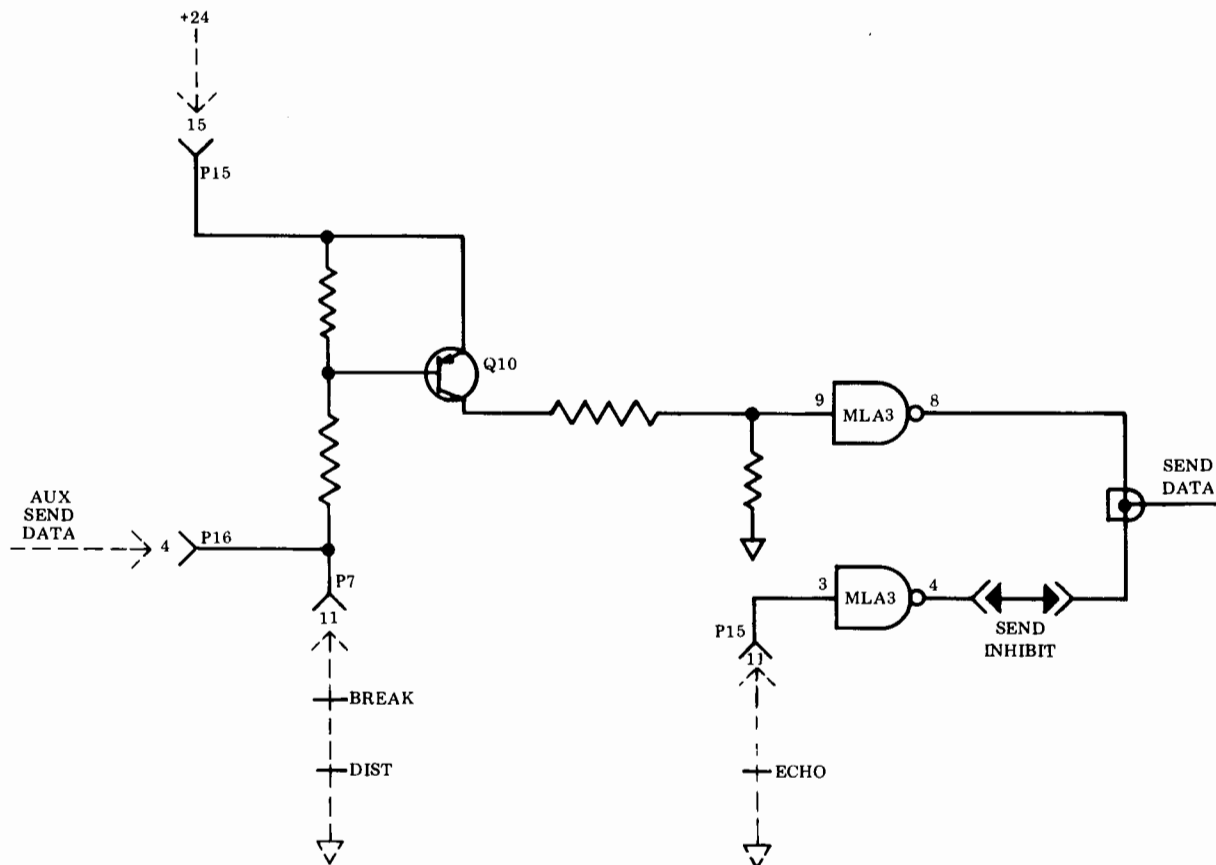

Figure 4 - Send Data Circuits

CONTROL LOGIC CARD (TP322491)

3.02 The TP322491 circuit card provides the control logic and interface between the teletypewriter and the telephone line. A Data Access Arrangement (DAA) with telephone set is required to place and answer calls on the direct distance dialing network.

A. Send Data Circuits

3.03 The send data circuits of the control logic card are shown schematically in Figure 4. The distributor contacts are connected through the normally closed Break contacts and P7-11 to the base of Q10. With a mark (closed contact) in the distributor, Q10 is on and produces a high at MLA3-9. This drives MLA3-8 low, producing a low on the Send Data lead. An Aux Send Data input is provided at P16-4, and a

mark (low) applied at this point will also produce a low on the Send Data lead.

3.04 A space (open distributor contact or +24 v on Aux Send Data lead) causes Q10 to turn off, producing a low at MLA3-9 and a high on the Send Data lead.

3.05 The Send Inhibit option screw prevents data from being sent on-line when the ECHO button is depressed. With this option enabled, the Send Data lead is blinded by a low at MLA3-4 when the ECHO button is depressed. With the option disabled, the ECHO contacts have no effect on the Send Data lead.

3.06 An open Break contact disconnects the distributor contacts from Q10, and thus prevents the Send Data lead from following the changes in the distributor.

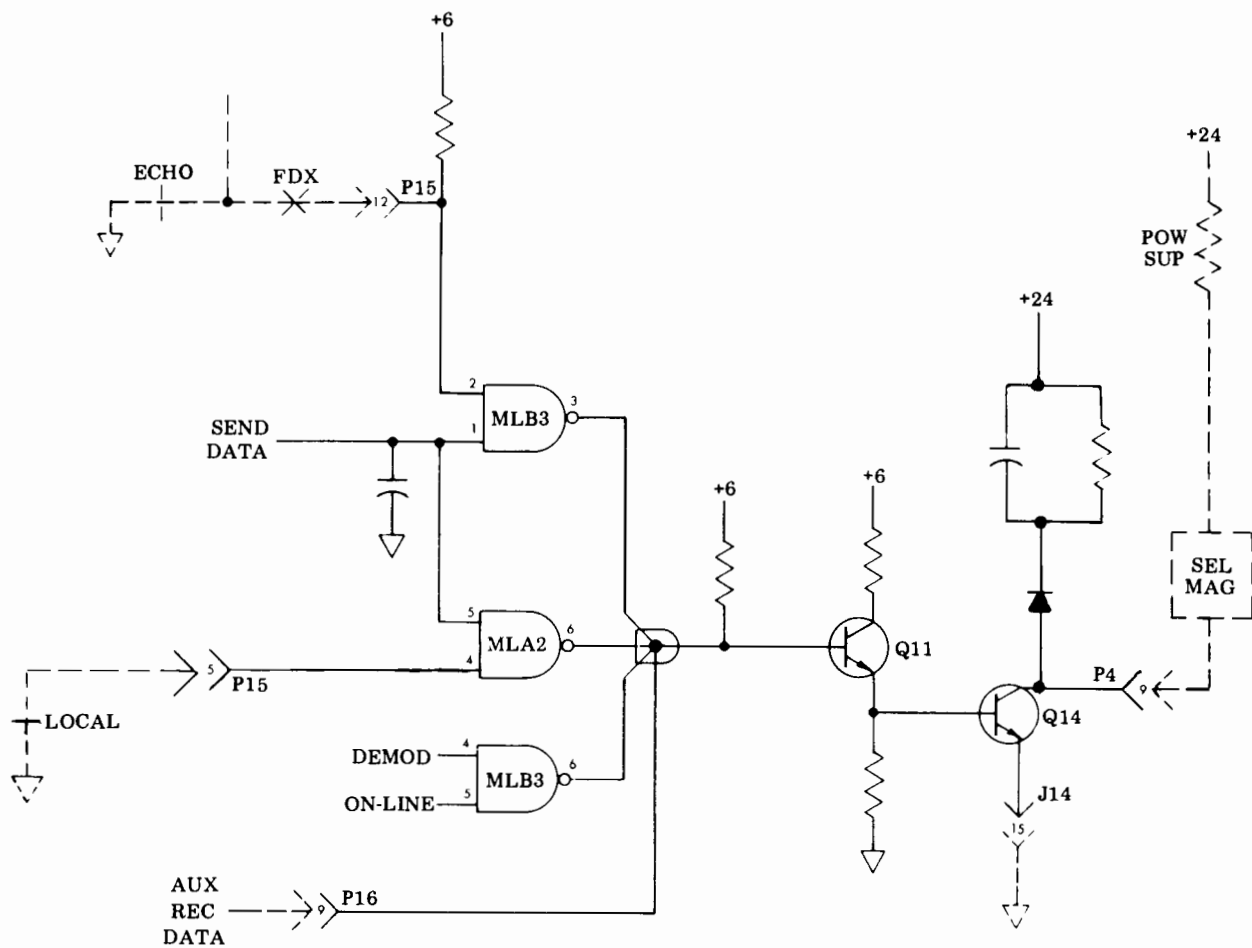

Figure 5 - Selector Magnet Driver Circuits

B. Selector Magnet Driver

3.07 The selector magnet driver is shown in Figure 5. Transistors Q11 and Q14, which drive the selector magnet, are controlled by a set of gates (and the Aux Rec Data input) wired-OR to the base of Q11. A high at MLB3-3, MLA2-6, MLB3-6, and the Aux Rec Data lead represents a mark, which turns on Q11 and Q14 and energizes the selector magnet. A low at any of the above points places a low (space) on Q11, turning Q11 and Q14 off to de-energize the selector magnet.

3.08 Gate MLA2-6 provides the selector drive signals in the local mode. With the LOCAL button depressed, a high applied through P15-5 to MLA2-4 enables this gate. Marks and spaces on the Send Data lead are applied to MLA2-5 to produce change at MLA2-6.

3.09 In the send mode, MLB3-3 provides the selector drive signals which provide local copy of the transmitted data. Assuming the FDX button is not depressed, a high at MLB3-2 enables this gate so it follows the signals on the Send Data lead (output of Figure 4). If the FDX

button is depressed, a low is applied to MLB3-2 and the gate is disabled. However, if the ECHO button is depressed, the low is blocked from MLB3-2 and the returned signals are printed out.

3.10 Local printout in the receive mode is controlled by MLB3-6. This gate is enabled by the On-Line signal at MLB3-5. The signals received from the demodulator (modem card TP322490) then provide variations at MLB3-4, resulting in mark and space variations at MLB3-6.

3.11 The Aux Rec Data lead permits operation from user-supplied equipment connected to P16-9.

C. Originate/Answer Mode Control

3.12 The originate or answer mode selection is provided by the circuitry of Figure 6. The state of dc flip-flop MLA2-8/MLA2-11 provides alternate highs or lows on the Ans Mode and Orig Mode leads. The reset state of this flip-flop is MLA2-8 high and MLA2-11 low (answer mode). Reset is provided by a low at MLA2-9.

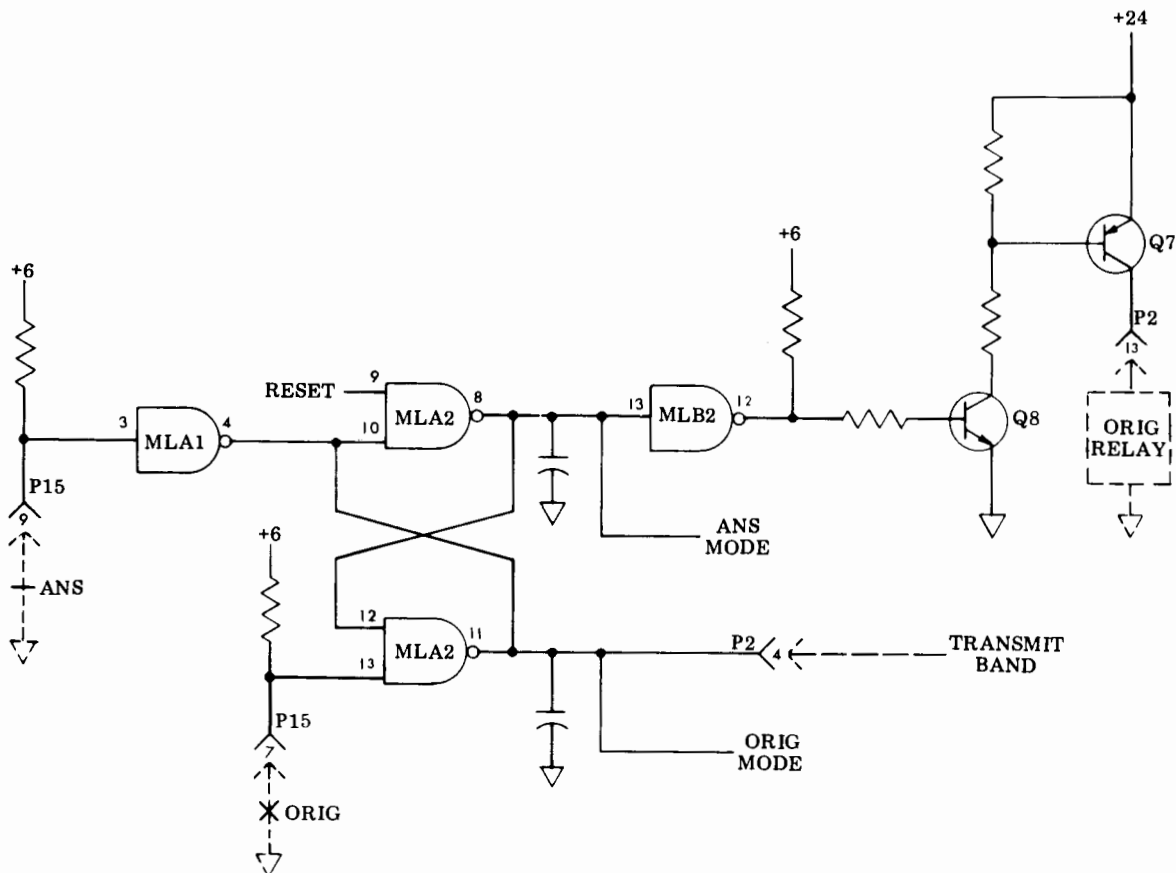

Figure 6 - Originate/Answer Mode Control Circuits

3.13 To place the circuit in the originate mode, the ORIG button is depressed. This places a low on MLA2-13, setting the flip-flop so that MLA2-11 is high and MLA2-8 is low. The low at MLA2-8, applied to MLB2-13, causes MLB2-12 to go high, turning on Q8 and Q7. This energizes the originate relay. The circuit remains in this state until a reset is applied to MLA2-9 or the ANS button is depressed to produce a high at MLA1-3. A high at MLA1-3 drives MLA1-4 and MLA2-10 low, resetting the flip-flop to the answer state and thus de-energizing the originate relay.

D. On-Line Control

3.14 The circuitry of Figure 7 initiates on-line operation in response to manual originate, manual answer, or auto answer control signals. In the off-line or reset state, this circuit provides a low at MLC3-3 and a high at MLC3-6.

3.15 Assuming the ANS button is not depressed, a low is applied through P15-9 to MLA1-13. This places a high at MLA1-12, and this high applied to MLC3-2 has

no effect on the on-line flip-flop. If the ANS button is depressed, MLA1-13 goes high. This forces MLA1-12 and MLC3-2 low, setting the flip-flop to the on-line state (MLC3-3 high and MLC3-6 low).

3.16 Auto answer is provided by the R.I. contacts of an automatic DAA. Incoming ring pulses on the R.I. lead are integrated by C8 and after approximately a 200 ms delay, present a low at MLC3-1. This low sets the flip-flop to the on-line state.

3.17 The Orig Mode lead from the originate/answer flip-flop is monitored by MLA1-2. When the ORIG button is depressed (Figure 6), the resulting high on the Orig Mode lead forces MLA1-2 low. This low, applied to MLC3-2, sets the on-line flip-flop to the on-line state.

3.18 A high on the On-Line output of the flip-flop serves as an enabling signal on MLB3-9. The signals at the Send Data lead (MLB3-10) produce variations at MLB3-8 which are inverted by MLA3-6 and applied to the modulator of modem card TP322490.

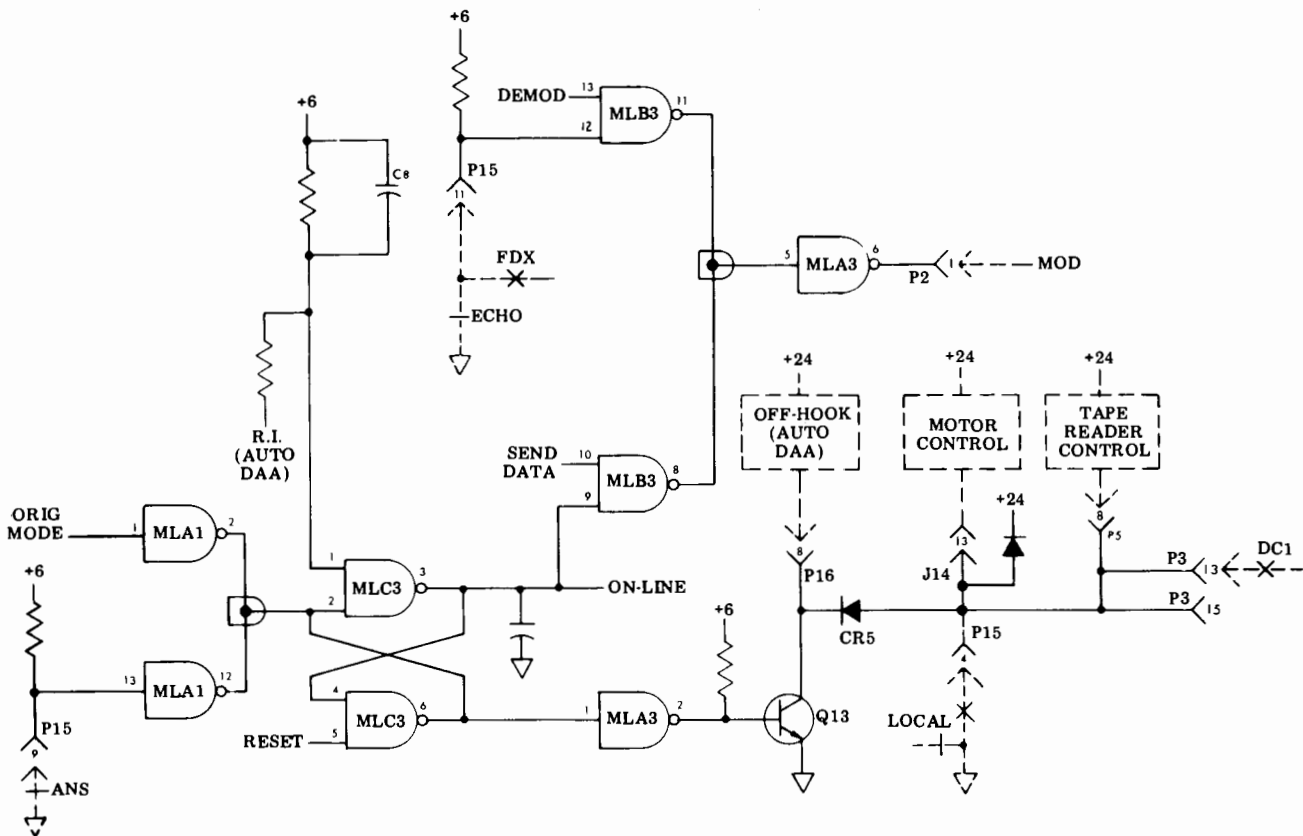

Figure 7 - On-Line and Motor Control Circuits

3.19 Gate MLB3-11 is used to couple the demodulator output to the modulator when the echo mode is selected. In their normal position the ECHO switch contacts disable this gate by applying a low to MLB3-12. When the ECHO button is depressed the contacts open and the gate is enabled. The demodulated signal at MLB3-13 is gated through MLB3-11 and MLA3-6 to the modulator, where it is transmitted to the remote terminal.



E. Motor Control

3.20 The circuits controlling the motor control relay and the off-hook and tape reader control relays are also shown in Figure 7. In the on-line mode, the low at MLC3-6 is inverted to produce a high at MLA3-2. This turns on Q13, energizing the off-hook, motor control, and tape reader control relays. In the clear mode MLC3-6 is high and MLA3-2 is low to turn off Q13. This de-energizes all three relays. In the local mode transistor Q13 is again turned off by a high at MLA3-2. However, the normally open contacts of the LOCAL switch close and energize the motor control and tape reader control relays. The off-hook relay is not energized in this mode because it is blocked from the local contacts by CR5.

3.21 A DC1 signal can be used to energize the tape reader relay. As shown in Figure 7, the DC1 provides a stunt box contact closure to ground which energizes the tape reader control relay. The off-hook relay is blocked by CR5 as explained for local operation.

F. Carrier Control, Originate/Answer Lamps

3.22 The circuit of Figure 8 monitors the carrier received by modem card TP322490 and the state of the originate/answer flip-flop (Figure 6) to light the ORIG or ANS lamp and to control the local carrier supplied to the remote terminal by the modem.

3.23 The Carrier Detect signal (high) from the modem is applied through P2-8 to MLB2-3, producing a low at MLB2-4. This low is inverted by MLB2-10 to produce a high at MLA2-2 and MLB1-2. Depending on the state of the originate/answer flip-flop, MLA2-3 or MLB1-3 will go low. If the ANS button is depressed the flip-flop will be in the answer mode

and a high at MLB1-1 will cause MLB1-3 to go low. This low, applied to MLB1-12, forces MLB1-11 high and turns on Q1 to energize the ANS lamp. The high on the Ans Mode lead is also applied to MLB1-10. With a high on the On-Line lead (MLB1-9), MLB1-8 goes low and forces MLB1-6 high to turn on the Carrier Control lead. The Carrier Control signal, fed to the modem, turns on the carrier to the remote terminal. In the answer mode, a low on the Orig Mode lead disables MLA2-3 to prevent the ORIG lamp from turning on.

3.24 If the auto answer option is enabled, R.I. signals from an auto DAA are applied through P16-11 to MLB1-13. Each ring pulse places a low on MLB1-13, forcing MLB1-11 high to turn on Q1 and energize the ANS lamp. Thus, the lamp flashes to indicate the call. The operator can answer the call or depress the ANS button to place the terminal in the answer mode.

3.25 If the ORIG button is depressed, the originate/answer flip-flop places a high on MLA2-1 to enable this gate. A Carrier Detect signal from the modem results in a high on MLA2-2, forcing MLA2-3 low. Transistor Q9 is normally on, and turns off when MLA2-3 goes low. Monostable multivibrator MLC1 times-out in approximately 450 ms, determined by the C5R6 charge time, and MLC1-6 then goes high to turn on Q2 and energize the ORIG lamp. MLC1-8 goes low when MLC1 times-out, and this low serves as a clock pulse to flip MLC2. The resulting low at MLC2-8 is applied to MLB1-4, forcing MLB1-6 high. This high is applied through P2-7 to the modem, where it is used to produce the carrier to the remote terminal.

3.26 If the terminal is switched out of the originate mode, or if the carrier is lost, the resulting low at MLA2-1 or MLA2-2 forces MLA2-3 high to turn on Q9. This causes MLC1 to revert to its initial state, and the low at MLC1-6 turns off Q2 to de-energize the ORIG lamp. However, the high at MLC1-8 has no effect on MLC2. This flip-flop does not reset and turn off the Carrier Control lead until the on-line flip-flop is reset to place a low on MLC2-10.

3.27 The Demod (P2-14) and Remote Carr Aux Control (P16-10) leads provide normal and inverted equivalents of the Carrier Detect signal for customer-provided equipment and for demodulator data receive circuits.

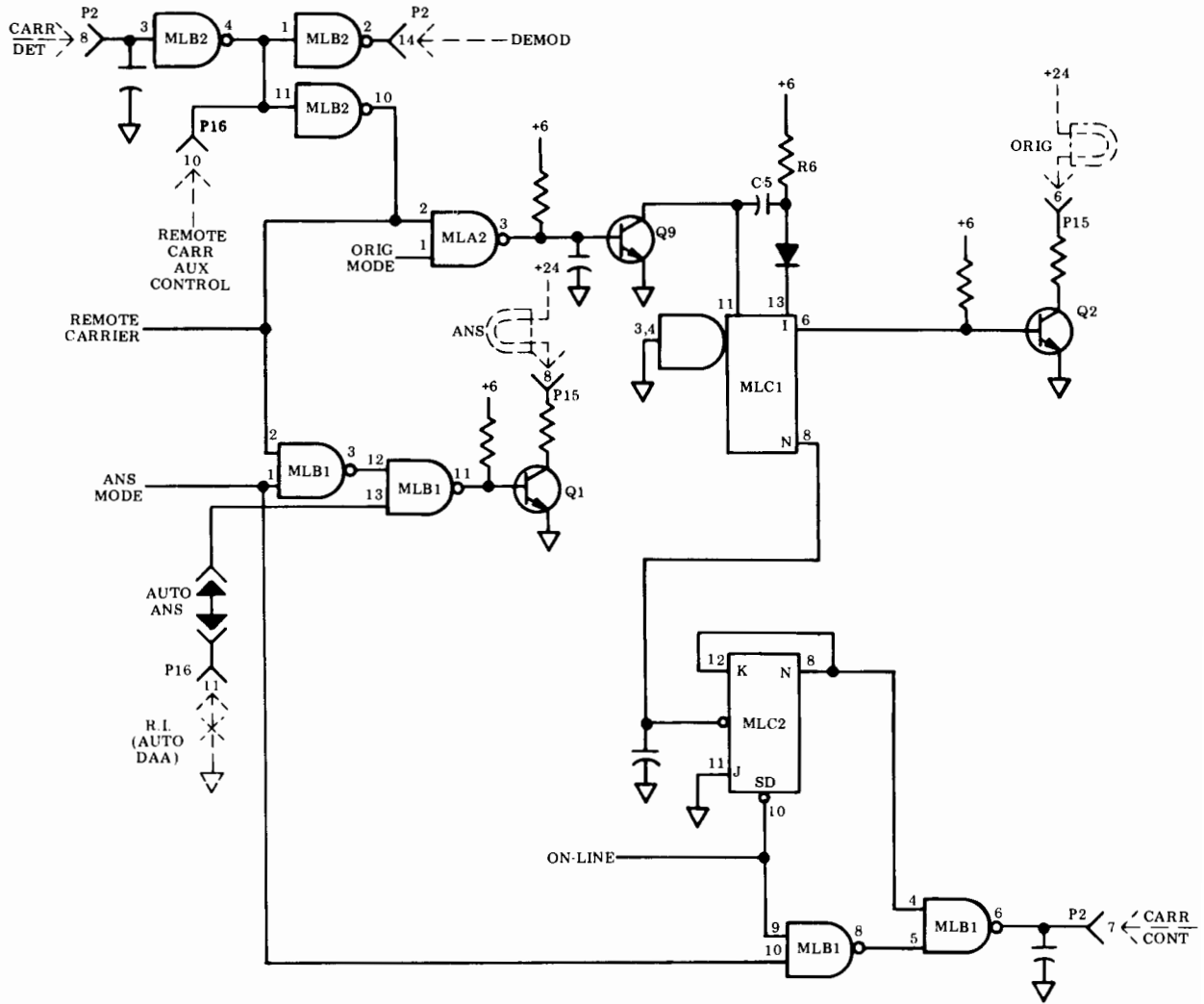

Figure 8 - Carrier Control and Originate/Answer Lamp Control Circuits

G. Answer-back Control

3.28 Figure 9 shows the circuits that control the answer-back. The inputs to this circuit are obtained from the carrier control, originate/answer circuits of Figure 8. The input at MLB2-9 is the gated Ans Mode and On-Line signal from MLB1-8 in Figure 8. The input at MLB2-5 is the inverted Carrier Detect signal from MLB2-4 in Figure 8. The outputs at MLB2-8 and MLB2-6 are wired-OR to control the state of the answer-back flip-flop.

3.29 With no carrier from the remote terminal, and with the local terminal in other than the answer mode, MLB2-9 and MLB2-5 are both high. This places a low on the K and SD inputs of the flip-flop, and at MLC3-10. The low on MLC3-10 holds MLC3-8 high, forcing MLC3-11 low to turn off Q12 and prevent the answer-back from being tripped. In this state the answer-back can be operated only by depressing the HERE IS key.

3.30 When the carrier is received from the remote terminal, MLB2-5 goes low and MLB2-6 attempts to go high. If the terminal is in the answer mode, (a low at MLB2-9), the wired-OR is permitted to go high because of the highs at both MLB2-8 and MLB2-6. This high is applied to MLC3-10. The flip-flop is initially in its set state, so MLC2-6 is high, placing a high on MLC3-9. Thus, the high on MLC3-10 forces MLC3-8 low. MLC3-11 goes high, turning on Q12 and energizing the answer-back trip magnet.

3.31 The Send Data lead is connected to the clock pulse input of the flip-flop. Once the answer-back cycle is initiated, the first space-to-mark transition of the answer-back message clocks the flip-flop and switches MLC2-6 low. This low, applied to MLC3-9, forces MLC3-8 high and MLC3-11 low to turn off Q12 and de-energize the trip magnet. The flip-flop remains in this state until MLB2-8 or MLB2-6 goes low to set it back to its initial state for the next call. Thus, a call in the answer mode triggers a cycle of the answer-back, and the answer-back message itself turns off the trigger circuit.

H. Reset Circuits

3.32 The manual and automatic reset circuits of Figure 10 are used to reset the various control circuits on the TP322491 logic card. A power-on reset is provided by capacitor C6 whenever the terminal is turned on. The initial low across C6 provides a high at

MLA1-10 and a low at MLA1-6 which serves as a reset pulse for the logic circuits. C6 charges in approximately 200 ms, effectively removing the reset pulse to permit circuit operation. Diode CR2 limits the voltage across C6 to about 6.5 v. Diode CR1 discharges C6 rapidly when the power is turned off.

3.33 Reset is also produced by closure of the EOT contacts or by depressing the CLEAR button, either of which places a low directly on the wired-OR which forms the Reset lead. Depressing the LOCAL button provides a reset by placing a high on MLA3-11 and thereby forcing MLA3-10 low.

3.34 If the Paper Alarm option screw is omitted, reset is also produced by a paper alarm condition. When the alarm occurs, the normally closed contacts open to place a high on MLA1-9. This forces MLA1-8 low, providing a reset which inhibits answering any further calls. The normally open contacts close to energize the ALARM lamp. If the paper alarm option screw is installed, a permanent low is placed on MLA1-9. The only effect of the alarm condition is then to light the ALARM lamp.

3.35 Absence of remote carrier also produces a reset. When the terminal goes on-line, the on-line flip-flop (Figure 7) places a high on MLA3-13. This forces MLA3-12 low, turning off Q4, Q6, and Q3. With Q3 off, C7 charges toward +6 v through R10. When the charge reaches about -0.5 v (nominally 25 seconds), Q5 turns on. If the remote carrier is not present at the drain when Q5 turns on, a low is coupled to the source to provide a reset. Loss of carrier during transmission has the same effect. The timer is disabled when the on-line flip-flop is reset.

MODEM CARD (TP322490)

3.36 The TP322490 circuit card operates as a modulator/demodulator (modem) to provide signal conversion between the teletypewriter and telephone line. The modulator receives start-stop dc signals from the teletypewriter distributor and produces Frequency Shift Keying (FSK) signals suitable for transmission on the telephone line. The demodulator receives FSK signals from a remote terminal and converts them to dc signals suitable for operation of the teletypewriter. When used with the TP322491 logic card and a Data Access Arrangement (DAA), the modem provides all functions of a low speed FSK data set.

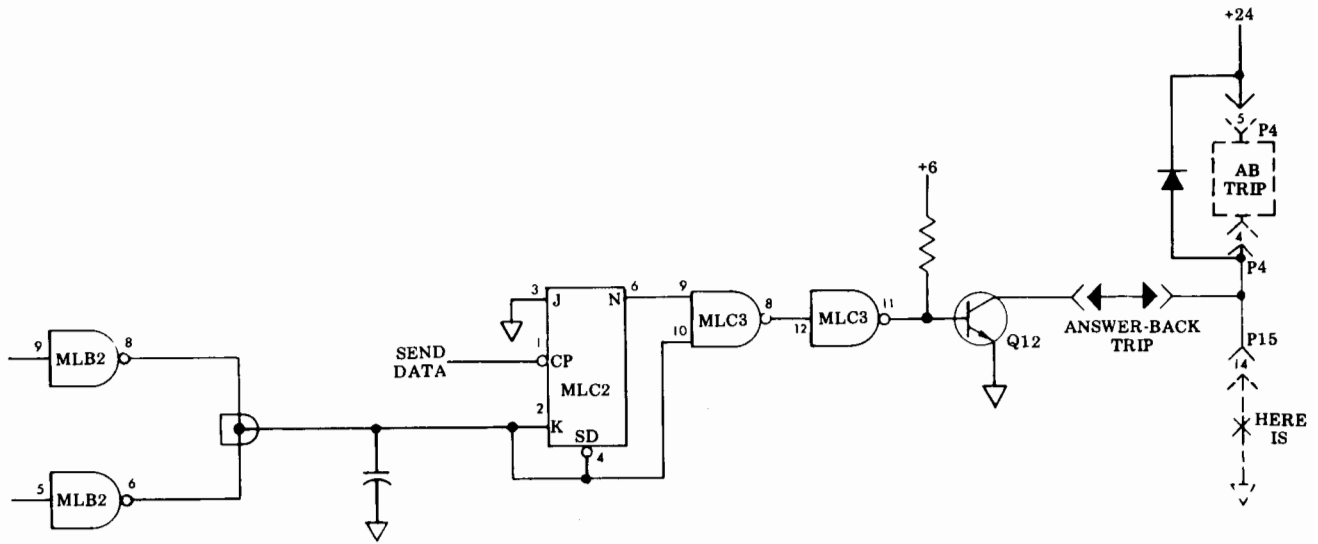

Figure 9 - Answer-back Control Circuits

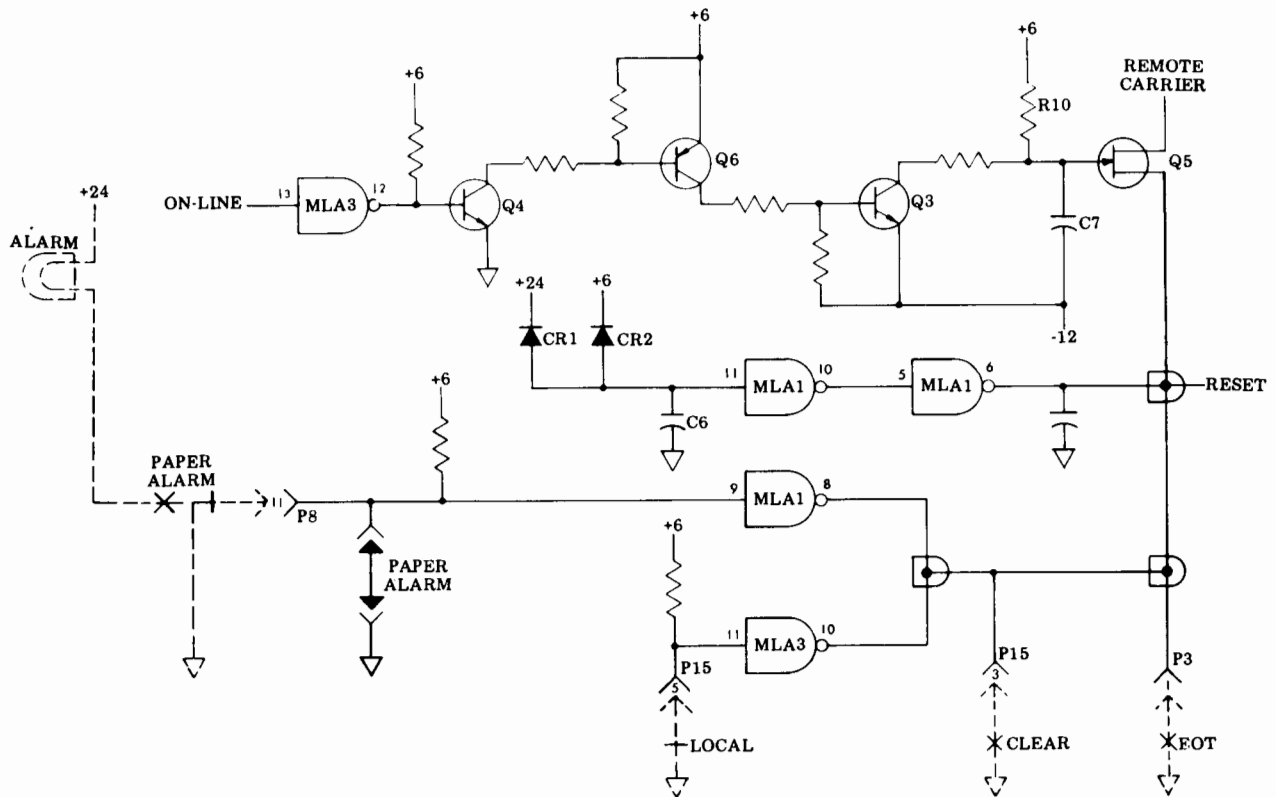

Figure 10 - Reset Circuits

3.37 The circuits on the modem card are illustrated in Figures 11 through 15. These circuits are shown in their entirety in wiring diagram 1216SD. They are broken-up and simplified in this section to emphasize the basic elements of the modem, which are described in the following paragraphs.

A. Tone Input/Output Circuits

3.38 The circuits of Figure 11 select and filter the marking and spacing tones fed from the modulator to the DAA and from the DAA to the demodulator. Switching is provided by relay K1, which responds to the Transmit Band signal from the originate/answer flip-flop on logic card TP322491. Filtering is provided by a low-pass filter (Z3, Z4, C19, C22, and C23) and a high-pass filter (Z1, Z2, C17, C20, and C21). Transformer T1 provides impedance matching between the DAA or telephone line and the filter circuits.

3.39 In the answer mode, the Transmit Band signal applied through J2-13 is low and relay K1 is de-energized. The K1 contacts are in the normal states shown in Figure 11. Incoming carrier signals applied between J2-12 and J2-15 are stepped up by T1 and applied to the filters. Low frequency tones (1070 Hz = F1 space; 1270 Hz = F1 mark) are passed through the low-pass filter and contacts 8, 9 of K1 to the demodulator

amplifier. High frequency tones (2025 Hz = F2 space; 2225 Hz = F2 mark) are passed from the modulator through contacts 5, 6 of K1 and through the high-pass filter to T1, where they are coupled to the DAA or telephone line for transmission to the remote terminal.

3.40 In the originate mode, the originate/answer flip-flop applies a +24 v Transmit Band signal to J2-13, energizing relay K1. The K1 contacts change states, so the output of the high-pass filter is connected through contacts 10, 9 to the demodulator, and the modulator is connected through contacts 6, 7 to the input of the low-pass filter. Thus, low frequency tones from the modulator (1070 Hz = F1 space; 1270 Hz = F1 mark) are passed through the low-pass filter to T1, and are coupled to the DAA or telephone line. High frequency tones from the remote terminal (2025 Hz = F2 space; 2225 Hz = F2 mark) are passed through the filter to the demodulator.

3.41 As a result of this switching action, the demodulator receives high band signals (F2s and F2m) in the originate mode and low band signals (F1s and F1m) in the answer mode, and the modulator supplies low band signals (F1s and F1m) in the originate mode and high band signals (F2s and F2m) in the answer mode. The filters prevent unwanted frequency components from interfering with the operation of the circuits.

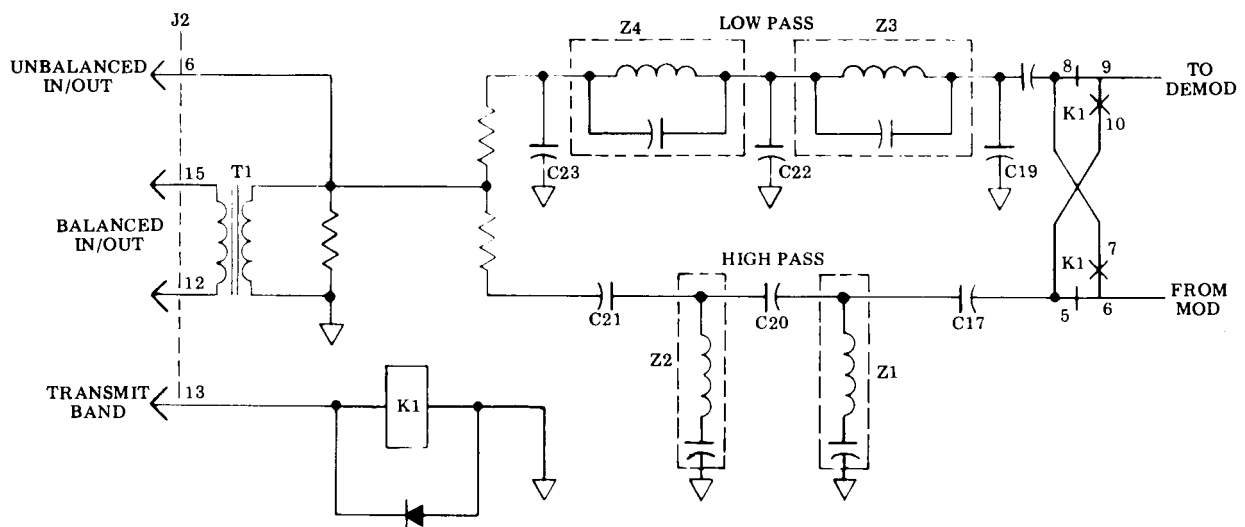

Figure 11 - Tone Input/Output Circuits

B. Demodulator Amplifier/Limiter and Discriminator Driver

3.42 Received tones are fed from the filter circuit through the K1 relay contacts to linear operational amplifier and limiter (OP1) as shown in Figure 12. The output of amplifier/limiter OP1 is applied to phase inverter Q4 and push-pull output transistors Q2 and Q3, which drive the primaries of discriminator transformers T2 and T3.

3.43 Transformer T2 is tuned to a frequency above the marking tone frequency (1270 or 2225 Hz), and T3 is tuned to a frequency below the spacing tone frequency (1070 or 2025 Hz). Thus, the voltage across T2 is high for marking tones and the voltage across T3 is high for spacing tones, and because of the push-pull operation the two voltages are out of phase. This results in the conventional S-shaped response curve for discriminator operation.

C. Discriminator Circuits

3.44 The discriminator circuits are shown in Figure 13. The tapped secondaries of T2 and T3 provide full-wave detection. The secondaries are tuned by capacitors C11 and C1

(plus C12 and C13 through the normally closed K1 contacts) in the answer mode. This provides detection of the 1070 Hz spacing tones (F1s) and 1270 Hz marking tones (F1m) received in the answer mode. In the originate mode the K1 contacts open to remove C12 and C13 from the secondary circuits. This reduces the capacitance and thereby raises the resonant frequencies of the T2 and T3 secondaries to detect the 2025 Hz spacing tones (F2s) and 2225 Hz marking tones (F2m) in the originate mode.

3.45 The mark and space outputs appear across R1C2 and R4C3, respectively. These dc voltages are series opposing so the spacing tones produce a negative output (the negative voltage across R4C3 exceeds the positive voltage across R1C2) and the marking tones produce a positive output (the positive voltage across R1C2 exceeds the negative voltage across R4C3).

3.46 The output of the discriminator is fed through low-pass filter R2C4, which attenuates any remaining carrier frequencies, to the gate of buffer amplifier Q1. This FET saturates when the carrier is marking (positive voltage on the gate), producing a low Receive Data Out at J2-14. The FET cuts off when the

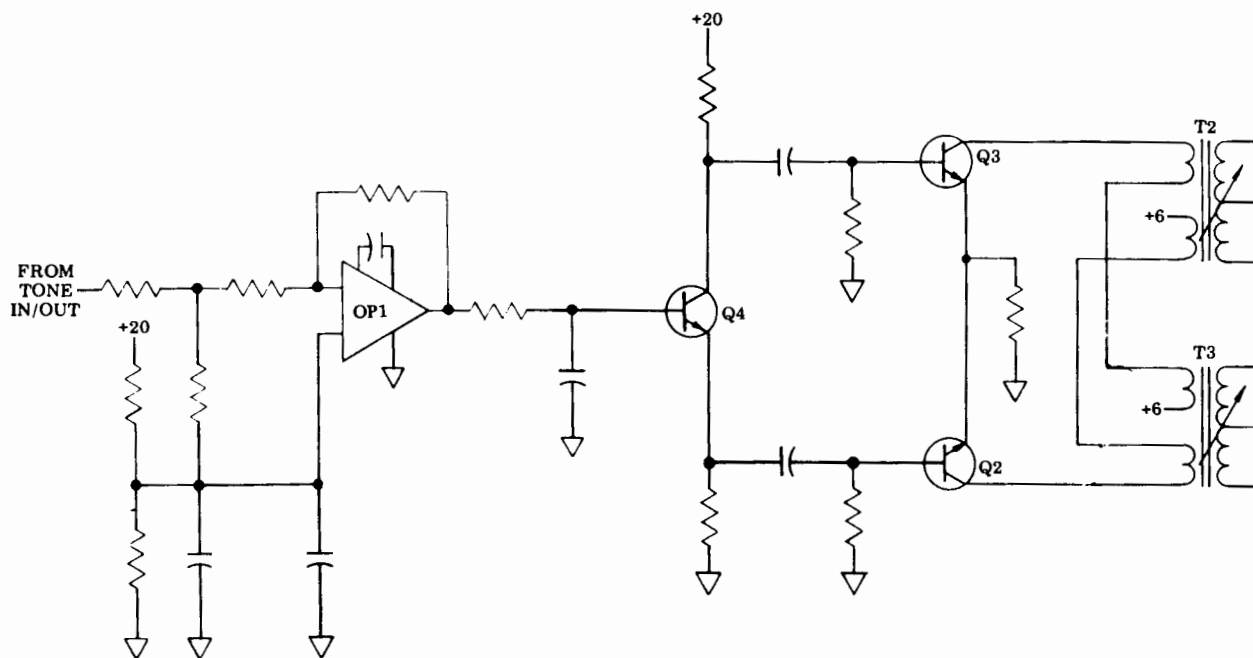

Figure 12 - Demodulator Amplifier/Limiter and Discriminator Driver Circuits

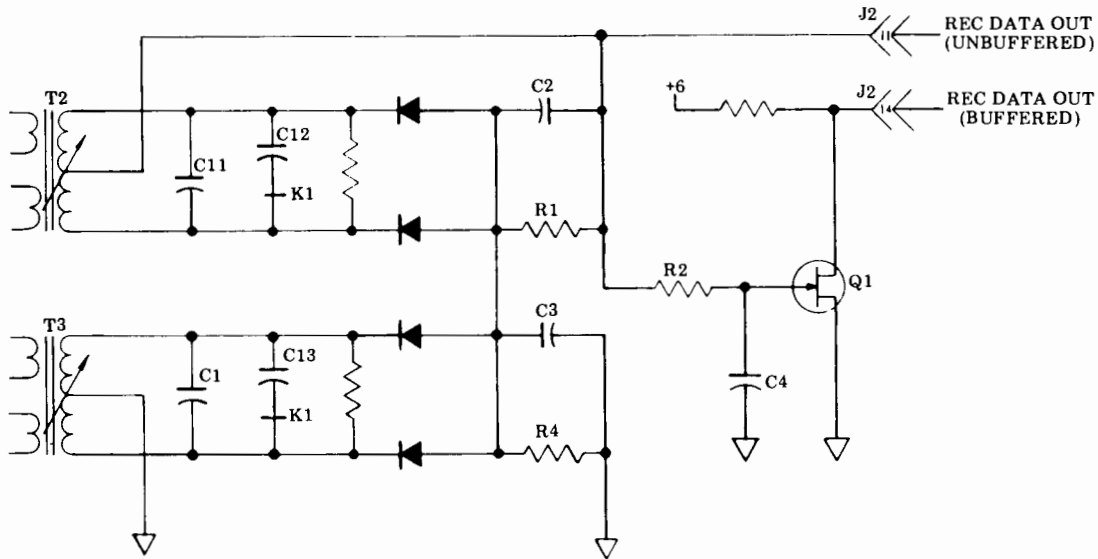

Figure 13 - Discriminator Circuits

carrier is spacing (negative voltage on the gate), producing a high Receive Data Out. An unbuffered Receive Data Out signal is applied directly from the discriminator output to J2-11 for customer use.

D. Carrier Detect Circuit

3.47 The Carrier Detect signal is produced by the circuit of Figure 14. This circuit samples the signal voltages across discriminator transformers T2 and T3 and produces an output only if adequate carrier is received. The carrier signals are coupled through C36 or C35 to C6. The pulses are rectified by CR7 in the base circuit of Q5. The output of Q5 is amplified and inverted by Q6 to produce a high at J2-8 when carrier is present and a low when no carrier or insufficient carrier is present. Capacitor C16 introduces a delay of approximately 0.2 second between the time carrier is present and the time the Carrier Detect signal appears at J2-8.

E. Modulator Circuit

3.48 The modulator produces the marking and spacing tones to be transmitted to the remote terminal. As shown in Figure 15, the clock pulses provided by a crystal-controlled oscillator are used to drive a nine-stage binary counter. The outputs of the counter stages are connected to four decoders which establish the high and low frequency marking and spacing tones.

3.49 The oscillator supplies a 1.00064 MHz clock signal to the first stage of the counter, which serves as a frequency divider. Each decoder receives inputs from all nine counter stages. The normal or inverted leads from the counter are selected so that all nine inputs to a given decoder are high on the following counts:

F1s - 467	F2s - 247
F1m - 394	F2m - 225

3.50 The clock pulse (CK) is also applied to each decoder. This negative pulse inhibits the decoders so the outputs cannot change until the clock pulse ends. This gives the counter stages time to switch to their new states and insures that the correct count will be decoded.

3.51 The Transmit Band and D.C. Data signals are also used to control the decoders. The Transmit Band signal is an indication of whether the terminal is in the originate or answer mode, and therefore selects either the low band (F1) or high band (F2) decoders. In the originate mode this signal is high to enable the two F1 decoders, and is inverted by MLA4-3 to disable the two F2 decoders. In the answer mode it is low to disable the F1 decoders and enable the F2 decoders.

3.52 The remaining control signal, D.C. Data, enables or disables spacing decoders F1s and F2s. As indicated in Figure 15, this signal is high for a space (enable) and low for a mark (disable).

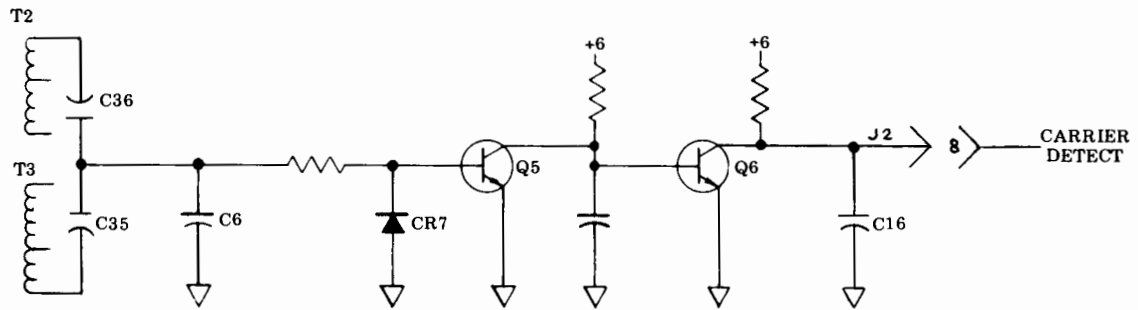

Figure 14 - Carrier Detect Circuits

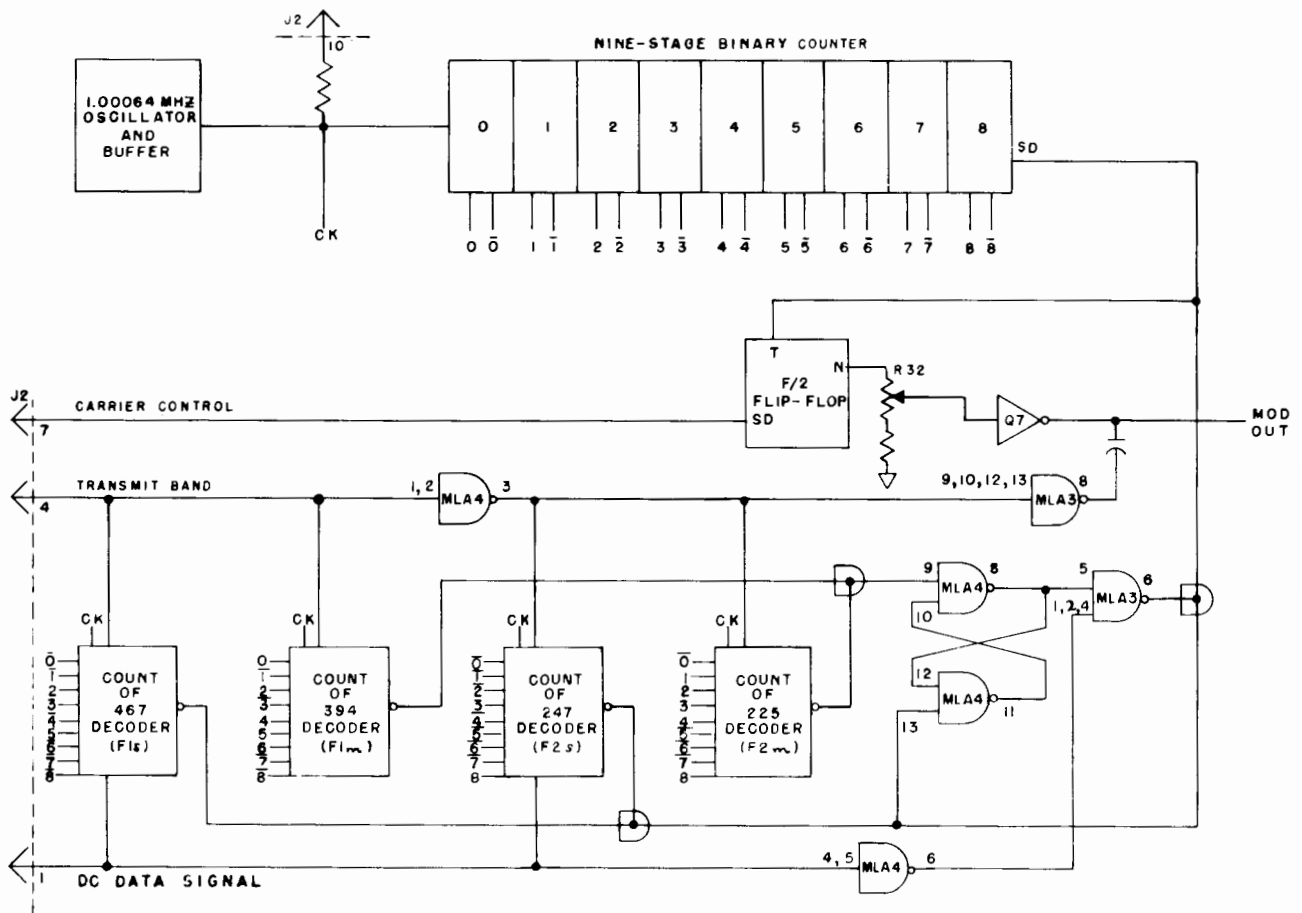

Figure 15 - Modulator Circuits

3.53 To see how the modulator generates the desired tone frequencies, assume the terminal is in the originate mode. The high Transmit Band signal enables F1s and F1m and disables F2s and F2m. The F1s and F1m carriers will therefore be produced by marking and spacing signals on the D.C. Data lead.

3.54 A mark (low) on the D.C. Data lead disables the F1s decoder, and is also inverted by MLA4-6 to place an enabling signal (high) on MLA3-1, 2, 4. When the count reaches 394, the output of the F1m decoder goes low. This low, applied to MLA4-9, sets MLA4-8 high to place a high on MLA3-5. Since MLA3-1, 2, 4 is held high by the marking signal, the high at MLA3-5 forces MLA3-6 low. This low is applied to the set direct leads of all counter stages, resetting the counter. It is also applied to the trigger input of a divide-by-2 flip-flop to toggle the flip-flop, and it is applied to MLA4-13 to reset the dc flip-flop and remove the high from MLA3-5. The reset on the counter clears the counter stages and thereby removes the reset pulse. The duration of the reset pulse is less than 100 ns, the nominal switching time of the logic.

3.55 The counter continues to cycle to the count of 394 as long as the mark is present on the D.C. Data lead. Each reset pulse at MLA3-6 is used to trigger the divide-by-2 flip-flop, and the output of the flip-flop changes for every reset pulse at its trigger input. The result is a square wave applied through R32 to amplifier Q7, which inverts the signal and applies it to the Mod Output lead.

3.56 At the clock frequency of 1.00064 MHz, the count of 394 produces a pulse frequency of approximately 2540 Hz at the output of the F1m decoder. Since the flip-flop toggles on every input pulse, the frequency of the rectangular wave at the modulator output is 1270 Hz, which is the desired marking tone frequency in the originate mode.

3.57 A space (high) on the D.C. Signal lead enables the F1s decoder and, inverted by MLA4-6, places a disabling signal (low) on MLA3-1, 2, 4. Although the output of F1m goes low at a count of 394, this change cannot be transferred to MLA3-6 as it was in 3.54. The count therefore continues to 467, which forces the F1s output low to provide counter reset and toggle the divide-by-2 flip-flop. The next count of 467 toggles the flip-flop as explained in 3.54, and the Mod Output is a rectangular wave at the desired spacing tone frequency (1070 Hz) as long as the spacing signal is present on the D.C. Data lead.

3.58 Notice that flip-flop MLA4-8, MLA4-11 is set by a low from the output of the F1m decoder every count of 394, even though this action has no effect on the output when a space is present. If a space-to-mark transition occurs between the count of 394 and 467, MLA3-6 goes low to produce a reset and trigger the divide-by-2 flip-flop.

POWER SUPPLY (TP188865)

3.59 The TP188865 power supply provides the dc operating voltages for the control and modem circuits of the call control unit. It also provides fused and switched ac operating voltages for the related equipment. The power supply circuitry is represented in the simplified diagram of Figure 16. More detailed circuitry is presented in wiring diagram 1195SD.

3.60 The 115 v ac obtained through the power cord is applied through power on/off switch S1 to the convenience outlet. This voltage can be used to operate equipment with a maximum power rating of 100 watts.

3.61 The Line Side (LS) of the line voltage is fused by F1 and applied to one of the normally open contacts of the motor control relay (K1). The LS line is connected through fuse F2 to one end of the power transformer primary. The Ground Side (GS) of the line is connected to the convenience outlet, to P14-11, and to the other side of the power transformer primary.

3.62 The secondary of power transformer T1 is tapped to provide the various operating voltages required by the call control unit. The full secondary voltage is applied to two full-wave rectifiers and filters which provide +24 v and -24 v dc outputs at P14-6 and P14-9, respectively. A portion of the secondary voltage is applied to a full wave rectifier and filter to provide +6 v dc which is fused and regulated to provide a regulated +6 v dc output at P14-10. A 6 v ac is applied from the secondary of T1 to P14-3. The common lead for each of these voltages terminates at P14-14 and P14-15.

3.63 The +24 v output is applied through current-limiting resistor R3 to P14-2. This output provides current for the selector magnet of the teletypewriter (Figure 5). The +24 v output is also applied to motor control relay K1, which connects through P14-13 to the motor control circuitry (Figure 7).

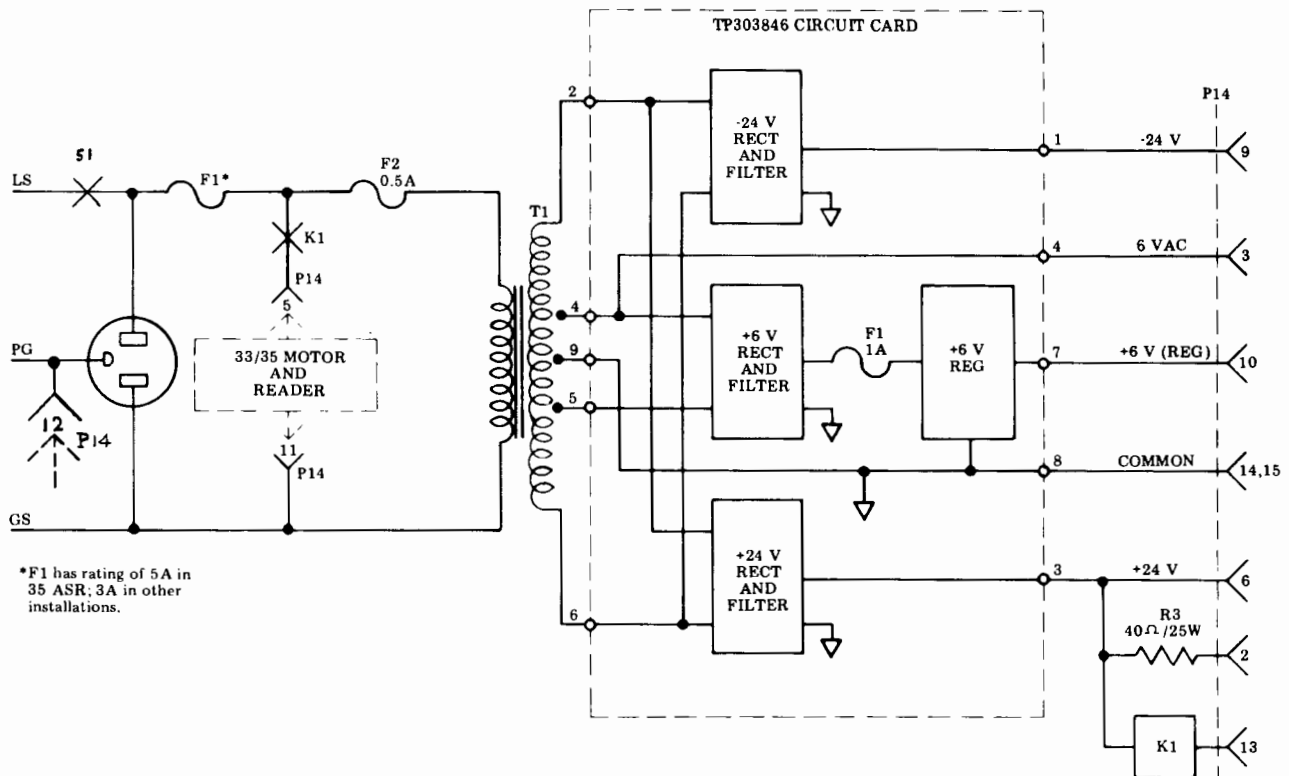

Figure 16 - Power Supply Circuits

3.64 As indicated by the broken line in Figure 16, the rectifier, filter, and regulator circuits are a part of circuit card TP303846. The card connector terminals are indicated by the numbered circles in the diagram.

4. INSTALLATION

4.01 The UCC39 call control unit is usually shipped assembled in the cabinet and connected to the teletypewriter. In this case the installer is required only to provide the signal and ac power connections and to check for any options or adjustments that may be necessary. If the call control unit is supplied separately, the installer must mount it in the cabinet and provide the necessary connections.

INSTALLING THE CALL CONTROL UNIT

4.02 The following instructions cover the various types of installation. Select the appropriate set of instructions and disregard those that do not apply.

A. Assembling the UCC39 Into a 33 RO, KSR, or ASR

4.03 With the cover of the teletypewriter open, position the call control unit so its mounting tabs align with the mounting holes on the right side of the teletypewriter base pan. Secure the unit to the base pan with the four mounting screws supplied with the unit. When the unit is properly mounted and adjusted, the pushbuttons on the keyswitch assembly will extend through the opening when the cover is closed.

4.04 Connect the cables from the teletypewriter to connectors 3 through 8 at the rear of the call control unit. (The connectors are numbered for identification.) Attach the ground lead at the rear of the UCC39 base to the corresponding tab on the 33 base pan.

4.05 Proceed with the interface cable connections, option check, and signal level adjustment in 4.30 through 4.33.

B. Assembling the UCC39 Into a 35 RO or KSR

4.06 With the cover of the teletypewriter open, position the call control circuit so its mounting tabs align with the mounting holes on the right side of the teletypewriter cabinet base. Secure the unit to the base pan with the four mounting screws supplied with the unit.

4.07 Remove the keyswitch assembly from its mounting bracket by loosening the four mounting screws and lockwashers (two each side; Figure 17). Remount the keyswitch assembly on adjustable bracket TP192270 of the teletypewriter cabinet base (front of call control unit) using the four TP181242 screws and TP125015 lockwashers supplied in the TP344395 set of parts.

Note: The answer-back relay and mounting hardware referred to in the following instructions are supplied with the TP344395 set of parts.

4.08 Assemble the TP178306 answer-back relay to the TP344353 bracket with two TP181242 screws inserted from the underside of the relay (Figure 18).

4.09 Connect the TP344355 cable leads to the relay terminals as indicated in Table A.

4.10 Mount the TP344354 insulator over the relay and bracket as shown in Figure 18. Secure the assembly with two TP7002 flat washers and TP3598 nuts on the TP181242 screws installed previously (Figure 18).

4.11 Mount the relay on the brackets from which the keyswitch assembly was removed. Secure the relay assembly by tightening the four mounting screws.

4.12 Connect the TP344355 cable leads to the terminals of the "T" power terminal block at the rear of the electrical service assembly as indicated in Table A.

4.13 Connect the cables from the electrical service assembly to connectors 3 through 8 at the rear of the call control unit. The connectors are numbered for identification.

4.14 Place a TP121249 cable clamp (TP344395 set of parts) on the TP344355 cable and secure the clamp to the LESU frame with a TP153841 screw, TP7002 flat washer, and TP3598 nut.

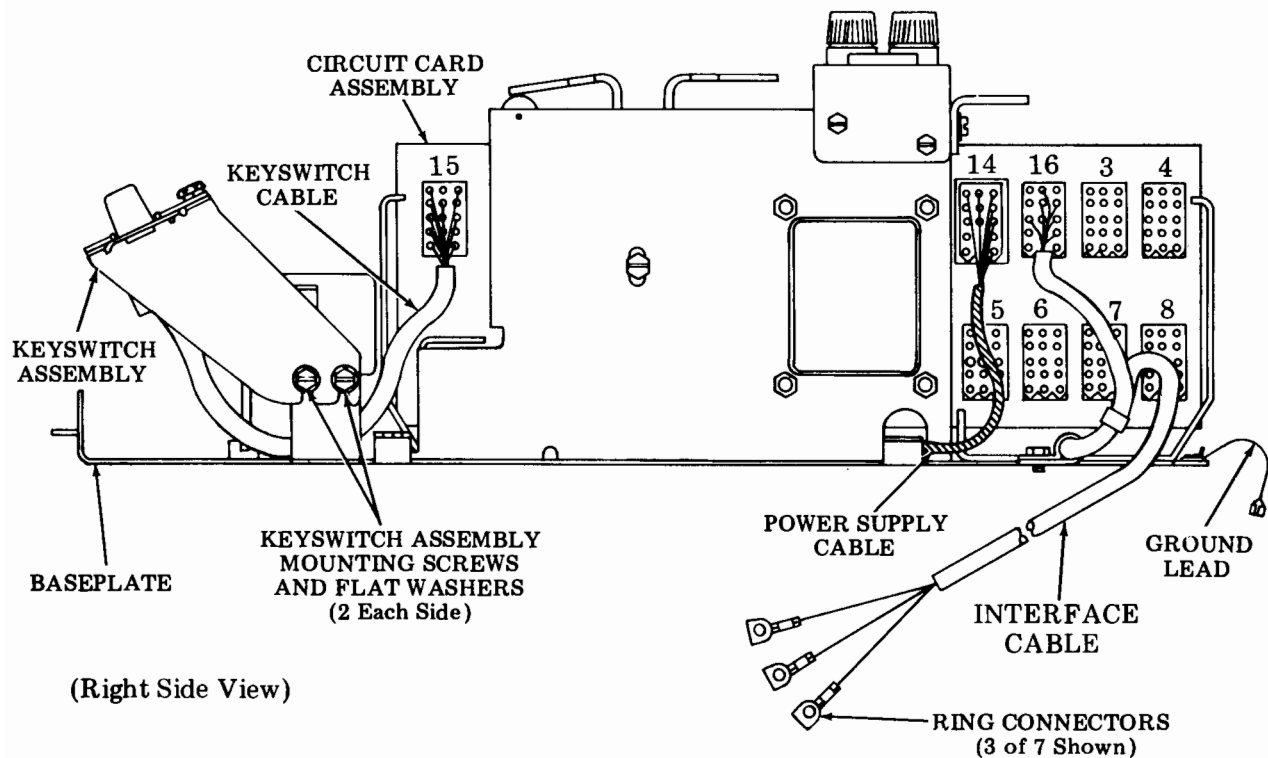

Figure 17 - UCC39 Call Control Unit Assembly

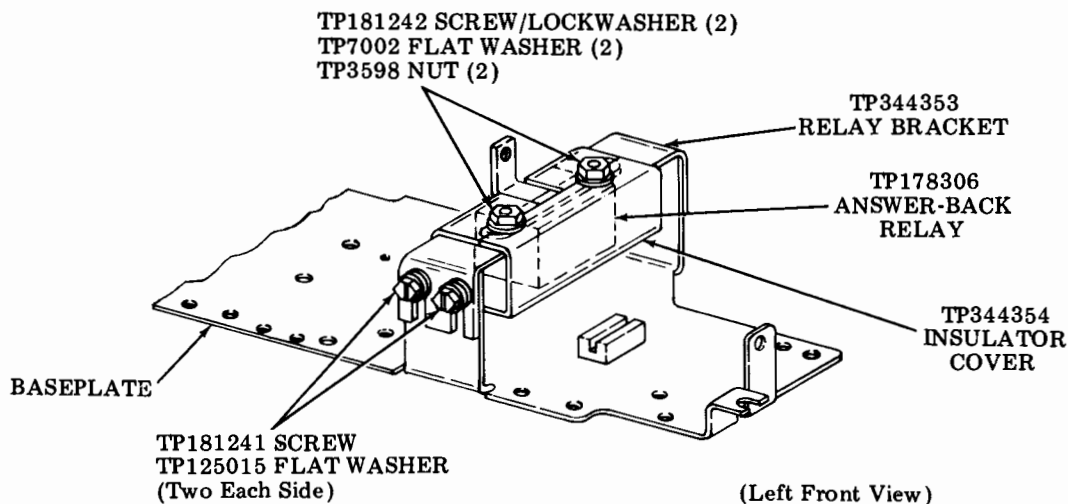

Figure 18 - Answer-back Relay Assembled to UCC39 Baseplate

4.15 Insert the TP186164 strap (TP344395 set of parts) in holes 8 and 9 of the "E" connector of the LESU.

4.16 Proceed with the interface cable connections, option check, and signal level adjustment in 4.30 through 4.33.

C. Assembling the UCC39 Into a 35 ASR

4.17 Remove cable connector 15 from its connector on the UCC39.

4.18 Remove the keyswitch assembly from its mounting bracket by loosening the four mounting screws and lockwashers (two each side; Figure 17). Remount the keyswitch assembly on adjustable bracket TP192270 of the cabinet base using the four TP181242 screws and TP125015 lockwashers supplied in the TP344395 set of parts.

Note: The answer-back relay and mounting hardware referred to in the following instructions are supplied with the TP344395 set of parts.

4.19 Assemble the TP178306 answer-back relay to the TP344353 bracket with two TP181242 screws inserted from the underside of the relay (Figure 18).

4.20 Connect the TP344603 cable leads to the relay terminals as indicated in Table A.

4.21 Mount the TP344354 insulator over the relay and bracket as shown in Figure 18. Secure the assembly with two TP7002 flat

washers and TP3598 nuts on the TP181242 screws installed previously (Figure 18).

4.22 Mount the relay on the brackets from which the keyswitch assembly was removed. Secure the relay assembly by tightening the four mounting screws.

4.23 Mount the call control unit near the right end of the lower shelf on the pedestal of the teletypewriter. Use the two TP153441 mounting screws, TP3639 lockwashers, and TP125231 nuts supplied with the call control unit. Insert the screws, with lockwashers, through the UCC39 baseplate into the pedestal shelf, and mount the nuts from the underside of the shelf.

4.24 Connect the TP344603 cable leads to the terminal of the "T" power terminal block at the rear of the electrical service assembly as indicated in Table A.

4.25 Connect the cables from the electrical service assembly to connectors 3 through 8 at the rear of the call control unit. The connectors are numbered for identification.

4.26 Connect the male plug end of the TP344602 extension cable to connector 15 of the cable from the keyswitch assembly. Connect the other end of the extension cable to connector 15 of the call control unit.

4.27 Place a TP121249 cable clamp (TP344395 set of parts) on the TP344603 cable and secure the clamp to the LESU frame with a TP153841 screw, TP7002 flat washer, and TP3598 nut.

TABLE A

TP344355 OR TP344603 CABLE CONNECTIONS

CABLE LEAD	TP178306 RELAY TERMINAL	"T" POWER TERMINAL BLOCK	"C" WIRING FIELD	
			LESU381 (35 ASR)	LESU382 (35 RO/KSR)
Black	1			
Red	3			
Slate*	4		C6K	C1F
Brown*	5		C5D	C2C
Blue		5		
Green		6		
White		7		
White/Brown		8		
White*			C3N	C4G
Yellow*			C3M	C3G
Orange			C8A	C5F
White/Black			C3A	C5D
White/Red			C6G	C5E
White/Green			C4A	C2D
Black/Yellow			C7A	C4F

*Wires so indicated are 18 AWG. All others are 24 AWG.

4.28 Insert the TP186164 strap (TP344395 set of parts) in holes 6 and 8 of the "E" connector of the LESU.

4.29 Proceed with the interface cable connections, option check, and signal level adjustments in 4.30 through 4.33.

CONNECTING THE INTERFACE CABLE

4.30 The interface cable (connector 16) must be connected to the DAA. The cable leads are connected by ring terminals to the corresponding DAA connection points as indicated in Table B. All leads are used for an auto DAA. Only the DT (orange) and DR (red) leads are used for a manual DAA, and the remaining leads may be cut or taped.

TABLE B

INTERFACE CABLE CONNECTIONS

COLOR OF WIRE	CONNECTION	
	AUTO DAA	MANUAL DAA
White	+24 v	NR
Blue	Common	NR
Black	Data Transmission (DA)	NR
Green	Off-Hook (OH)	NR
Yellow	Ring Indicator (RI)	NR
Orange	Data Tip (DT)	Data Tip (DT)
Red	Data Ring (DR)	Data Ring (DR)

NR = Not required. Lead may be cut or taped.

OPTIONS

4.31 Three screw options are provided on the TP322491 logic card. Sets are usually shipped with the options preprogrammed to the customer's order. The installer should check and, if necessary, program the options as shown in Table C. The screws are labeled on the circuit card.

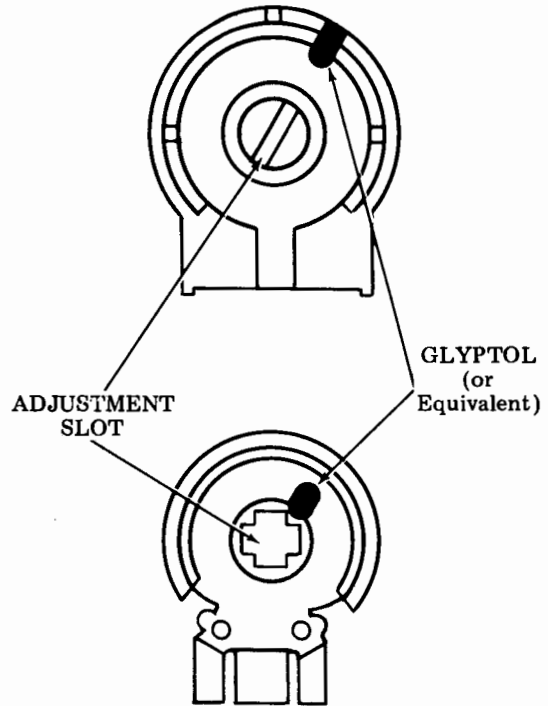

Figure 19 - Application of Glyptol to Secure Potentiometer Adjustment (Two Types of Potentiometers Shown)

SIGNAL LEVEL ADJUSTMENT

4.32 The level of the modulator output signal is set by potentiometer R32 on the TP322490 card. This level is preset before the call control circuit is shipped, but may require some adjustment at the time of installation.

4.33 The output level is factory adjusted to $-6 \pm 1/2$ dBm. If the specified input to the DAA is -6 dBm, as determined by the installer of the DAA, no further adjustment is required. If the specified maximum level to the DAA is other than -6 dBm, the level should be adjusted accordingly. This is done by connecting a 600 ohm noninductive resistor across the DT and DR leads of the interface cable and, with a voltmeter across the resistor, adjusting R32 to the following voltage level:

0 dBm - 0.8 v	- 8 dBm - 0.3 v
-2 dBm - 0.6 v	-10 dBm - 0.25 v
-4 dBm - 0.5 v	-12 dBm - 0.2 v
-6 dBm - 0.4 v	

After the adjustment is complete, cement R32 with a drop of glyptol as shown in Figure 19.

TABLE C

OPTION SCREWS ON TP322491 CONTROL LOGIC CARD

OPTION SCREW	OPTION	EFFECT ON OPERATION	
		SCREW IN	SCREW OUT
OPT 1	Send Inhibit	Keyboard and tape reader do not transmit to remote terminal in echo mode.	Keyboard and tape reader can transmit to remote terminal in echo mode.
OPT 2	Low Paper (Friction Feed) Paper Out (Sprocket Feed)	Low paper or paper out lights alarm lamp, but does not affect operation of terminal.	Low paper or paper out lights alarm lamp and prevents subsequent call connection with remote station. If TP322491 logic card has issue number 3 or lower, disconnect will occur during existing call.
OPT 4	Answer-back Trip	Answer-back is tripped upon call connection when remote carrier is received in answer mode.	Answer-back is not tripped by completion of call in answer mode.

Note: There is no option screw OPT 3 on the circuit card.

33 TAPE READER
 GENERAL DESCRIPTION AND
 PRINCIPLES OF OPERATION



CONTENTS	PAGE
1. GENERAL	1
2. DESCRIPTION	1
TECHNICAL DATA	1
3. PRINCIPLES OF OPERATION	2
OUTLINE OF OPERATION	2
DETAILED OPERATION	3
A. Tape Lid Mechanism	3
B. Control Mechanism	3
C. Distributor Trip Mechanism	5
D. Feed Magnet Mechanism	6
E. Sensing Pin Guide Mechanism	6
F. Contact Block Mechanism	7
G. Tape Feed Mechanism	9
H. Upstop Mechanism	10
4. FEATURES	10
MANUAL READER	10
A. Freewheeling Mechanism	10
B. Tight-Tape Mechanism	10
C. Tape-Out Mechanism	10
AUTOMATIC CONTROL FEATURES	12
A. Local Start	12
B. Remote Start	12
C. Reader Stop	12
D. FREE Position	15

1. GENERAL

1.01 This section provides the general description and principles of operation for the 33 tape reader. It is reissued to consolidate information and make a few minor corrections. Marginal arrows are used to indicate the changes.

1.02 The 33 tape reader is an 8-level electro-mechanical device which senses and transmits coded intelligence perforated in tape (Figure 1).

1.03 References to left, right, front, rear, consider the tape reader as viewed by the operator.

1.04 In the illustrations, fixed pivots are solid black, and floating points — those mounted on parts that move — are crosshatched.

2. DESCRIPTION

TECHNICAL DATA

Note: This equipment is intended to be operated in a room environment within the temperature range of 40°F to 110°F. Serious damage to it could result if this range is exceeded. In this connection, particular caution should be exercised in using acoustical or other enclosures.

2.01 Dimensions and Weight (Approximate)

Feeding and Sensing Component

Width	3-1/2 inches
Depth	4 inches
Height	3-1/2 inches
Weight	2 pounds

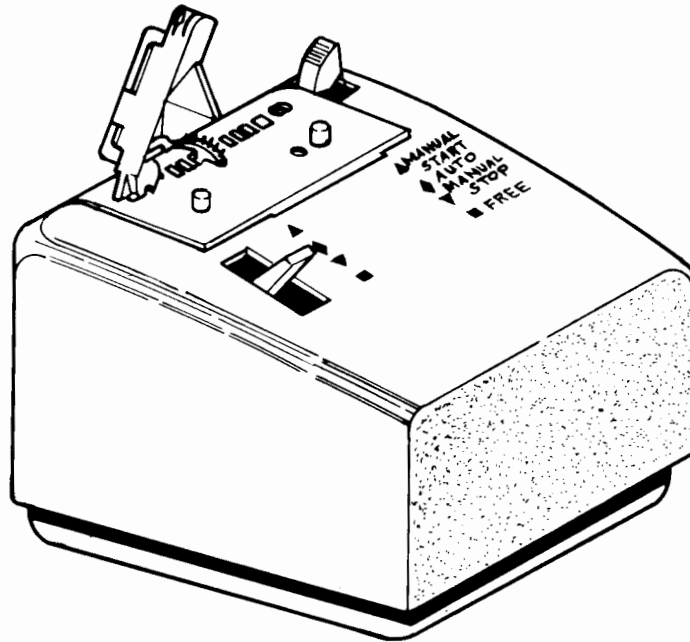

(Left Front View)

Figure 1 - 33 Automatic Tape Reader

Power Pack Component

Width	5-5/16 inches
Depth	2-7/8 inches
Height	3-3/4 inches
Weight	3/4 pound

2.02 Electrical — Power Pack

High Voltage:

Input	115 volts ac
Output	Min 137 volts dc @ 0.160 ampere

2.03 Feed Magnet

Power dissipation	2-1/4 watts
Nominal attraction time	8 to 11 milli-seconds at a nominal peak transient current of 0.220 ampere
Nominal release time	7 to 10 milli-seconds

CAUTION: HIGH VOLTAGE PERSISTS 10 SECONDS AFTER POWER IS REMOVED.

2.04 Speed 100 words per minute

2.05 Tape Specifications

Level	8-level
Width	1 inch
Code combinations per inch	10
Feed hole diameter	0.0465 inch

2.06 Signal Characteristics

Long telegraph loops	0.015 to 0.070 ampere at 48 to 240 volts dc inductive
Short telegraph loops	0.058 to 0.072 ampere at 16 to 22 volts dc resistive

3. PRINCIPLES OF OPERATION

OUTLINE OF OPERATION

3.01 The tape reader senses coded intelligence perforated in tape and transmits this intelligence as a parallel output.

3.02 The tape reader package consists of three mechanisms; the reader mechanism, the power pack, and the distributor trip mechanism (Figure 2).

3.03 The reader mechanism senses and feeds the tape. Other submechanisms within the reader mechanism transmit the intelligence as a parallel output. The reader mechanism mounts on the left side of the typing unit.

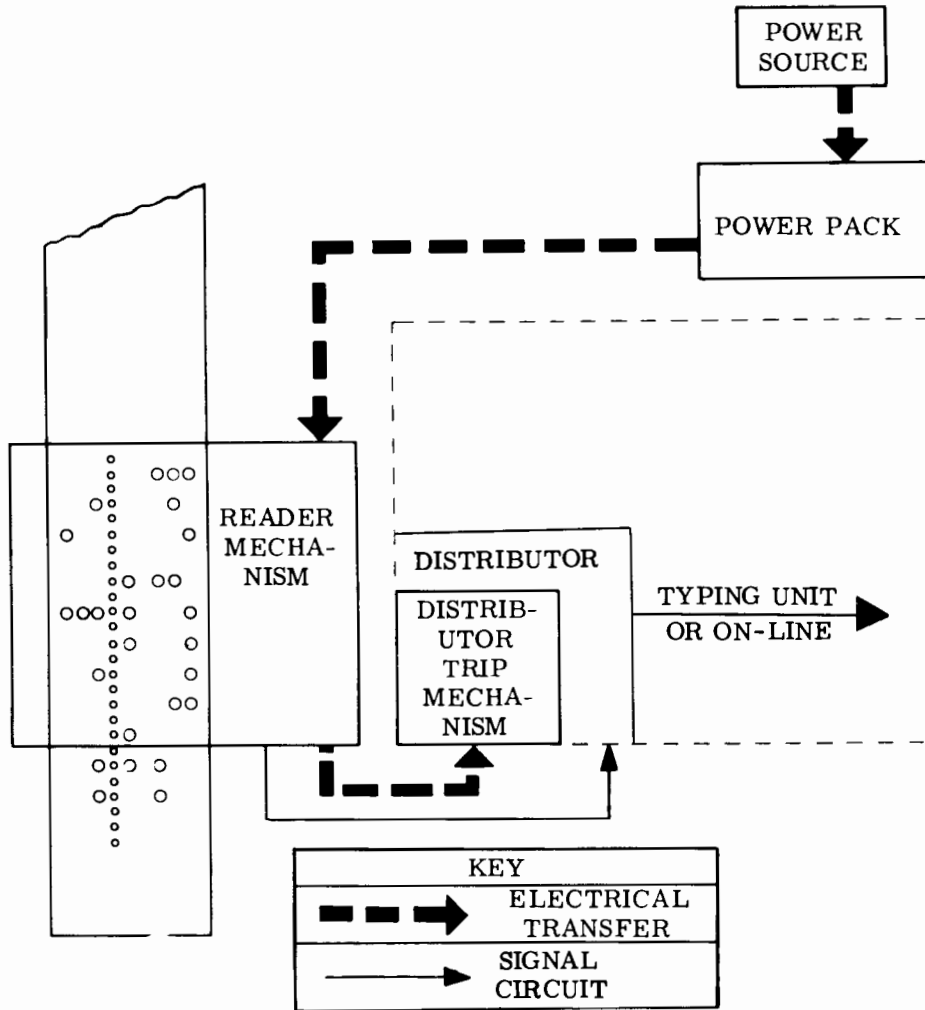

Figure 2 - Tape Reader Package with Major Mechanisms

3.04 The power pack provides direct current for the reader mechanism. The power pack is normally a part of the call control unit. Optionally, the power pack may be mounted in the stand.

3.05 The distributor mechanism receives the reader mechanism output and converts it into serial start-stop signals.

DETAILED OPERATION

A. Tape Lid Mechanism

3.06 When the tape lid latch handle is moved to the right, the spring biased tape lid swings open. Two locating pins guide the tape as it travels above the top of the plate (Figure 3).

B. Control Mechanism

3.07 In the manual reader there are three positions for the control lever: START, STOP, and FREE. In the automatic reader there are four positions for the control lever: MANUAL START, AUTO, MANUAL STOP, and FREE. When the control lever is moved to the START position (MANUAL START position for the automatic reader — Figure 4) the spring biased start contact wires are positioned on the start contact. Since the start contact wires and the start contact are wired in series with the distributor clutch trip coil in the typing unit, the coil energizes and releases the tape reader trip lever (Figure 5).

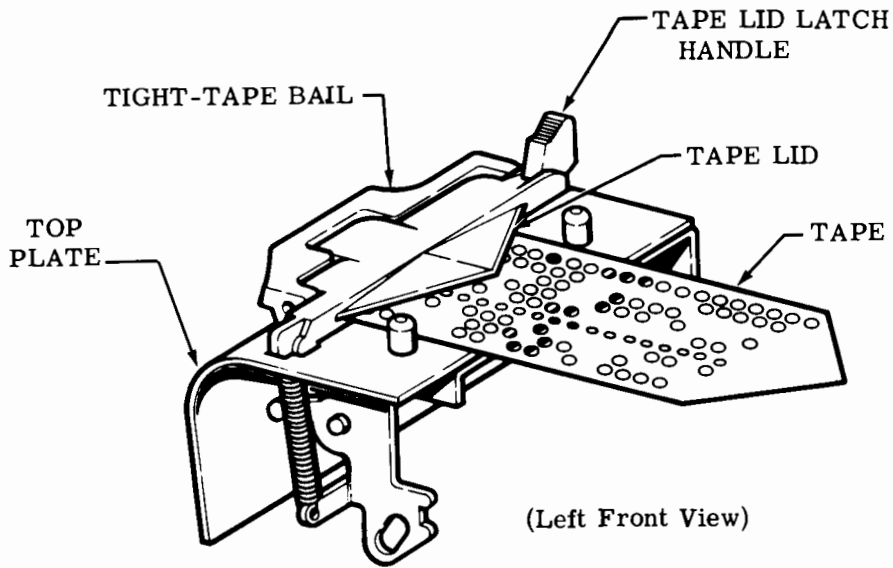

Figure 3 - Tape Lid Mechanism

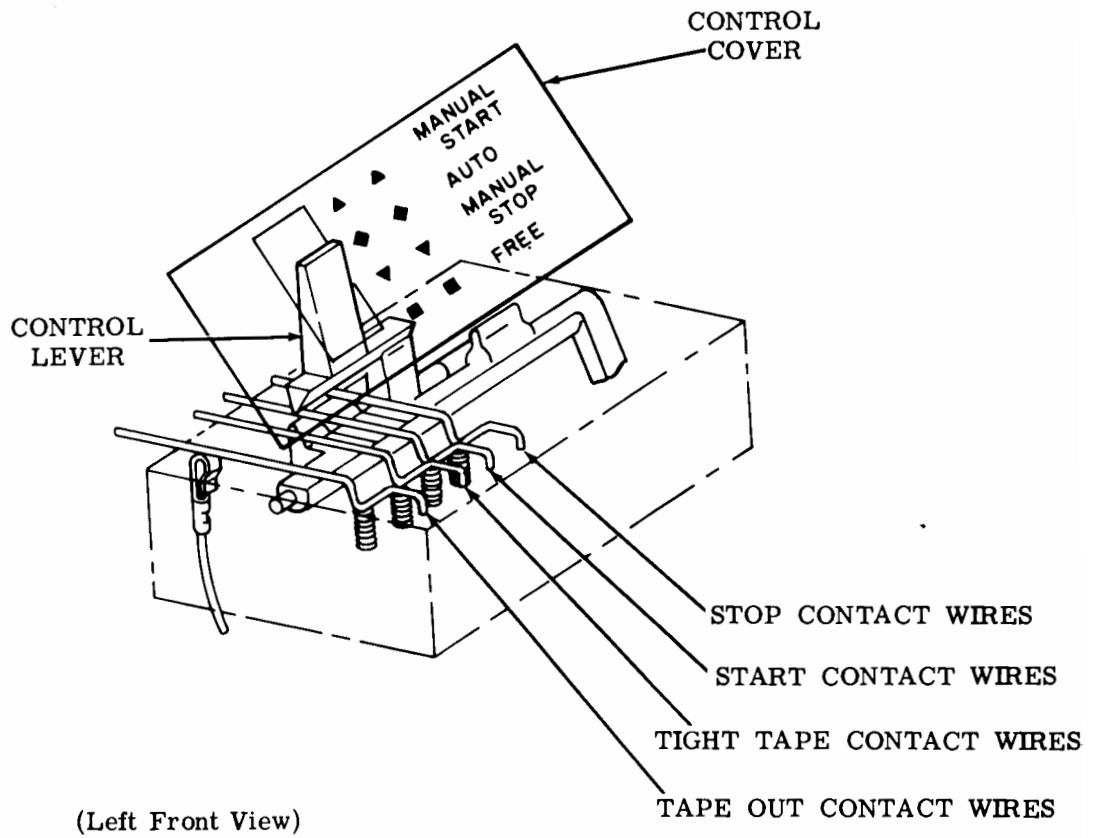

Figure 4 - Control Mechanism

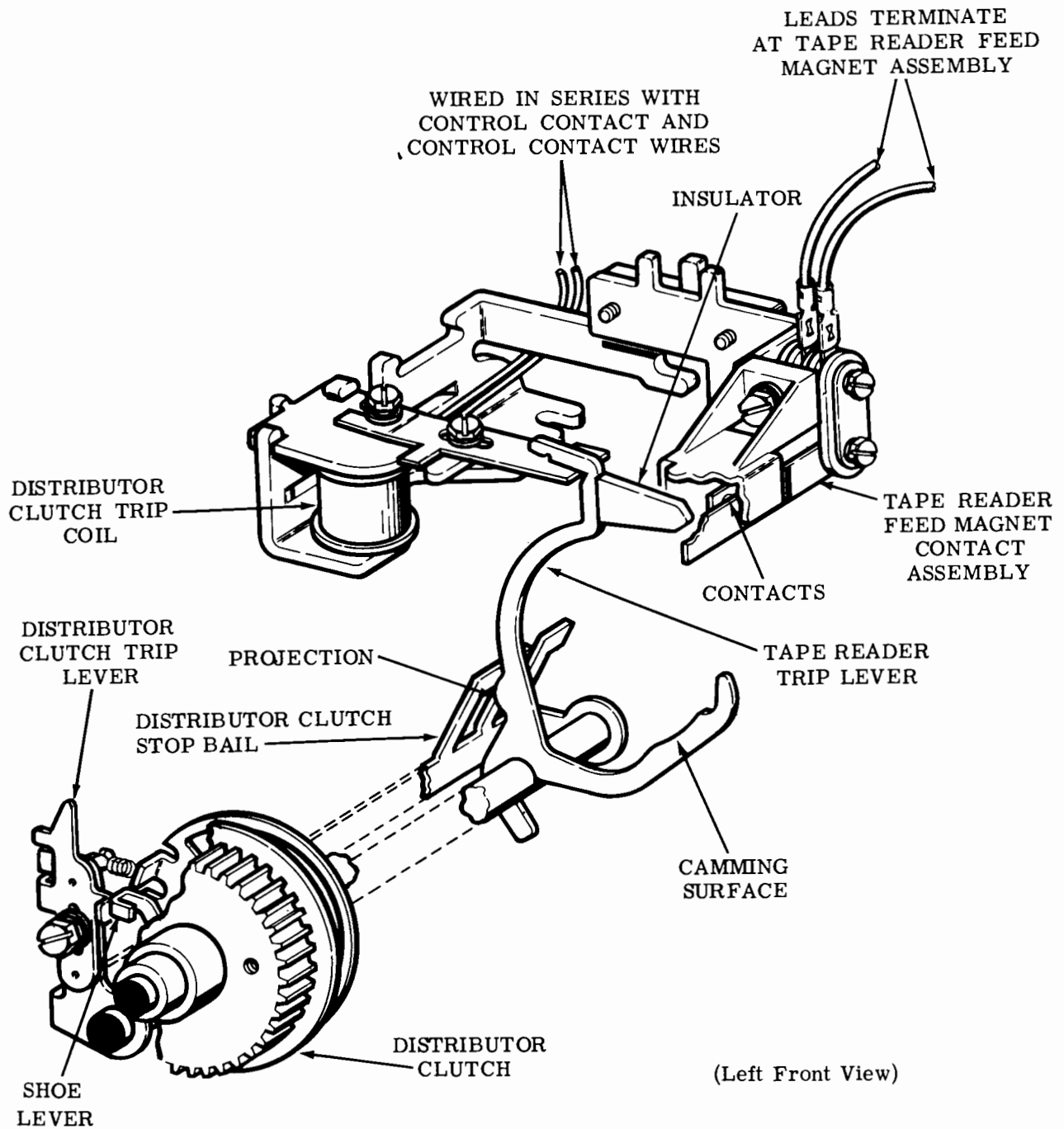

Figure 5 - Distributor Trip Mechanism

C. Distributor Trip Mechanism

3.08 When released the tape reader trip lever performs two functions; it closes the tape reader feed magnet contact assembly and trips the distributor clutch (Figure 5). The reader feed magnet contact assembly is closed by an

insulator on the back of the tape reader trip lever. In its travel, the tape reader trip lever rotates the distributor clutch stop bail by means of a projection. This motion is transferred to the distributor clutch trip lever which moves away from the shoe lever. The distributor clutch engages and the distributor cycle begins.

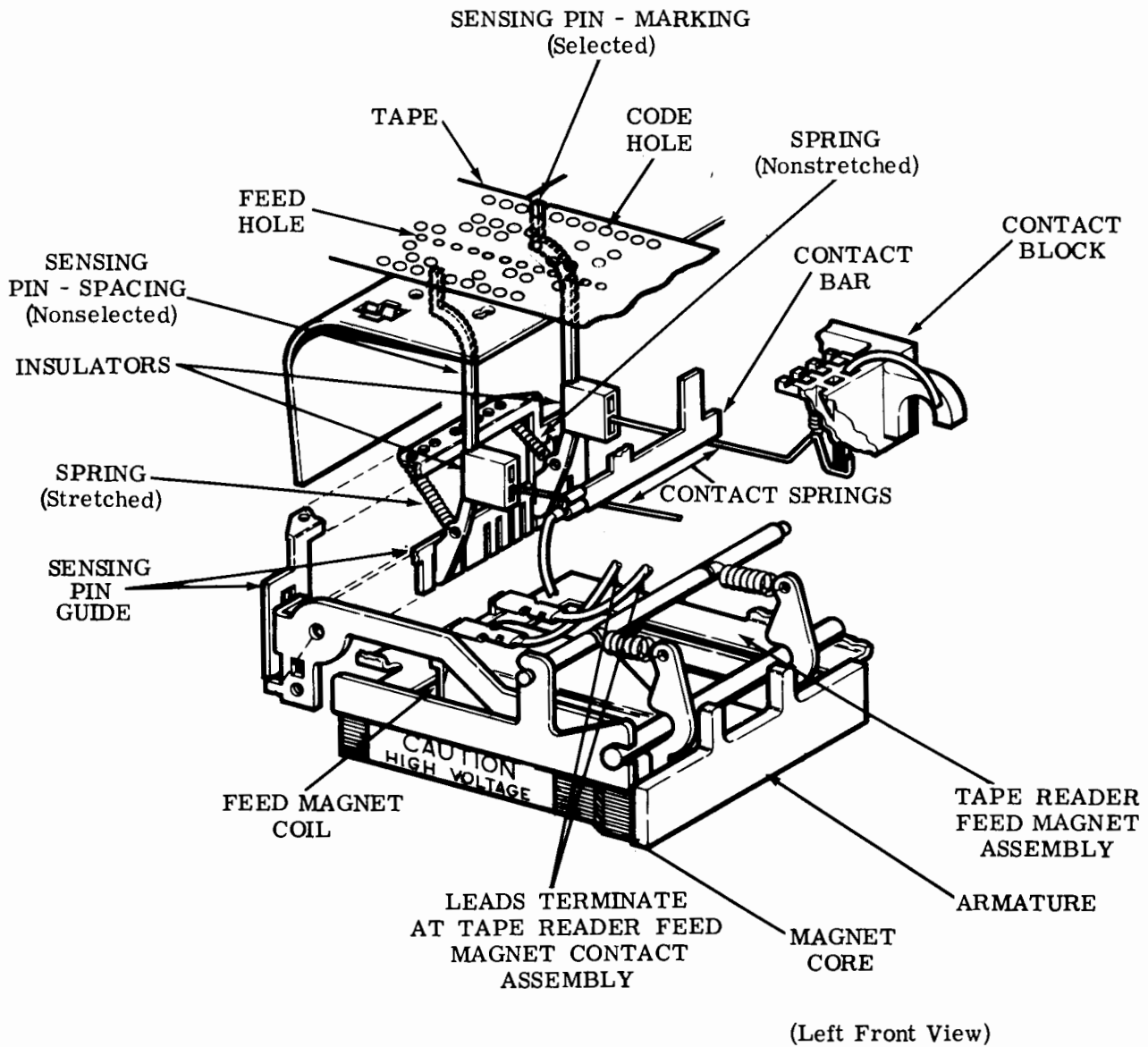

Figure 6 - Feed Magnet and Sensing Mechanism

D. Feed Magnet Mechanism

3.09 With the feed magnet contacts closed (Figure 5) the feed magnet in the reader mechanism is activated. The energized feed magnet coil attracts the armature (Figure 6). Rotating about its pivot the armature raises the armature extensions. Fastened to the ends of the armature extensions is a sensing pin guide.

E. Sensing Pin Guide Mechanism

3.10 In its upward travel the sensing pin guide carries with it eight spring-biased pins which sense the tape. Where a hole exists in the tape (marking) the sensing pin continues its upward travel and its associated spring remains unstretched. Where no hole exists in the tape (spacing) the sensing pin travel is blocked and its associated spring becomes stretched (Figure 6).

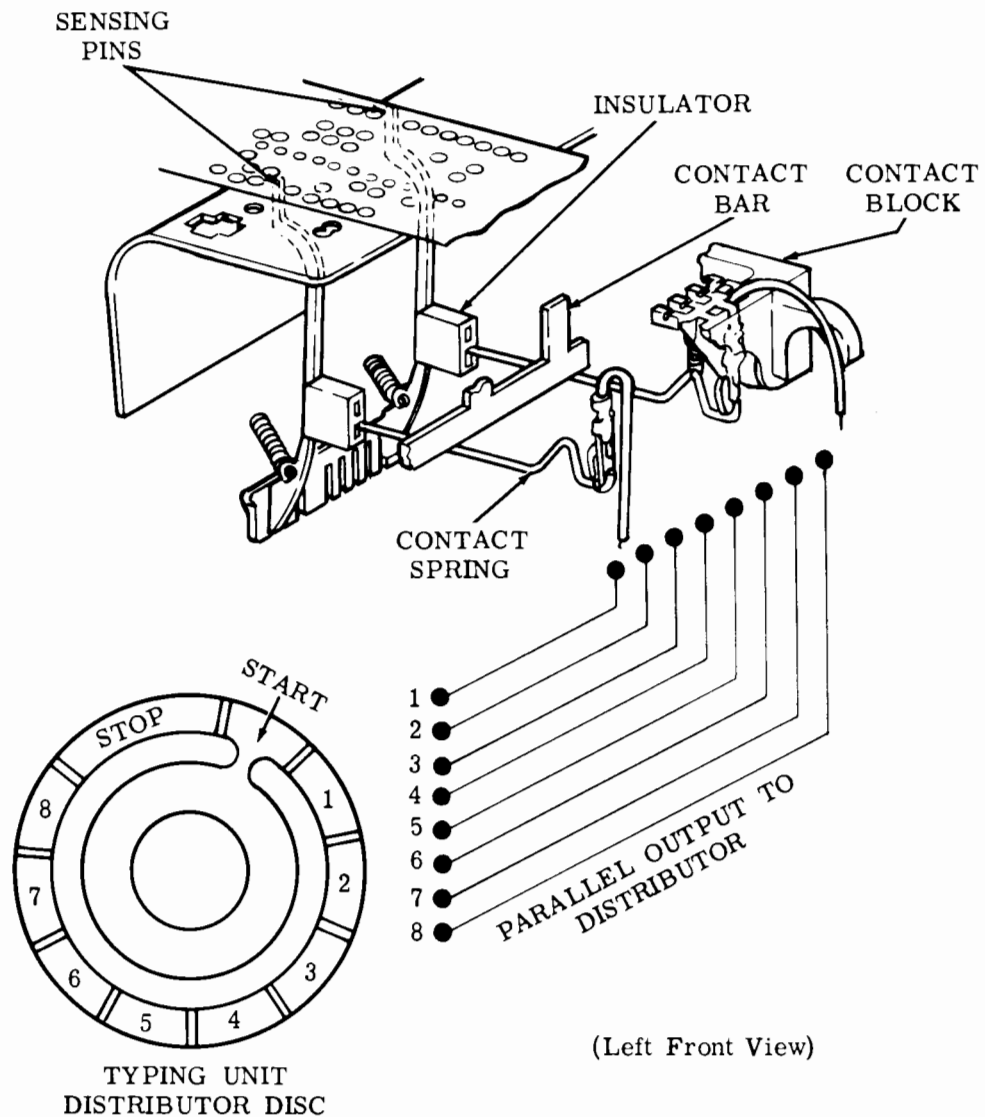
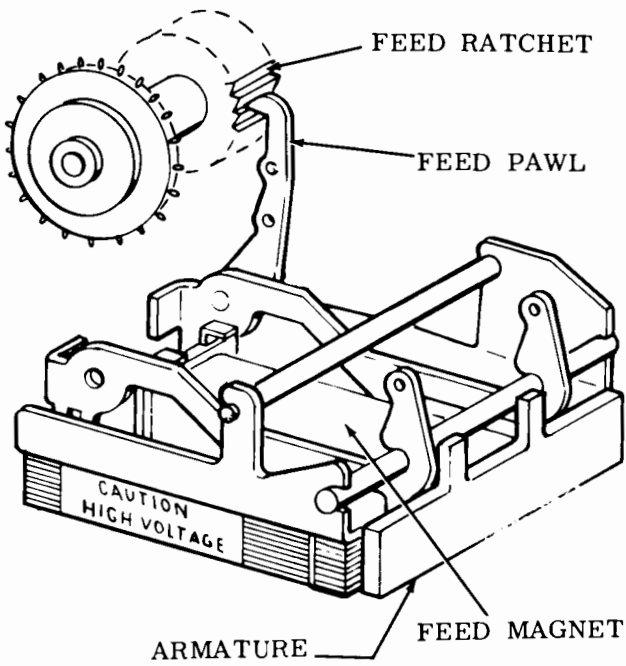

Figure 7 - Contact Block Mechanism

F. Contact Block Mechanism

3.11 There is an insulator attached to each sensing pin. The insulators hold eight contact springs in a down position, away from the contact bar (Figure 7). The eight contact springs are connected in parallel to corresponding segments on the distributor disc in the typing unit. If a sensing pin finds a hole in the tape (marking) it continues its upward travel. The

insulator attached to it also rises, allowing the contact spring to make contact with the contact bar (Figure 7). If a sensing pin does not find a hole in the tape (spacing) it remains in the down position, keeping the insulator down. This prevents the contact spring from making contact with the contact bar. Since all eight pins rise up simultaneously, the output going from the contact block to the distributor disc will be a parallel output.



(Left Front View)

Figure 8 - Feed Pawl Engagement

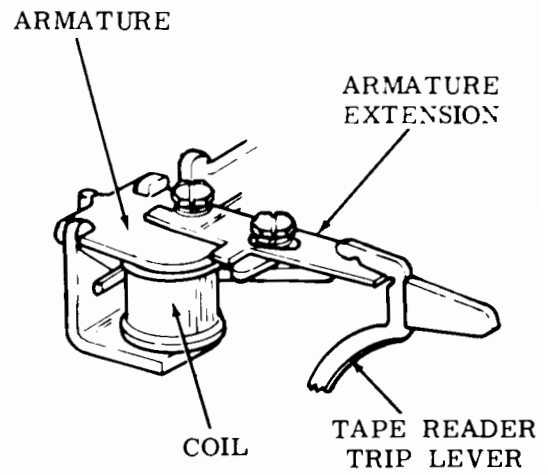

(Left Front View)

Figure 9 - Distributor Clutch Trip Coil

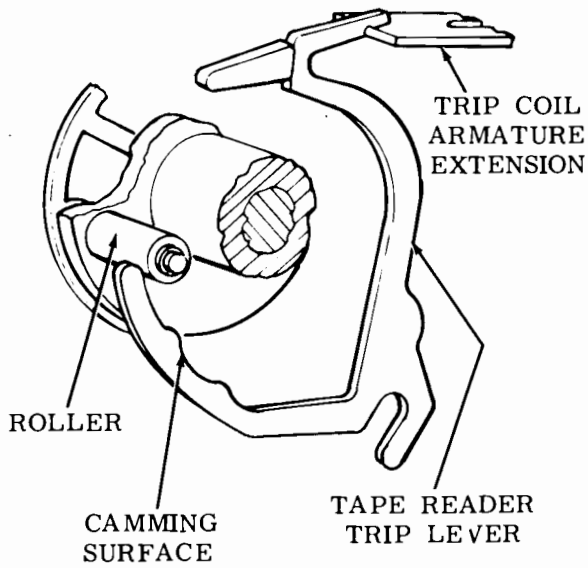

(Right Side View)

Figure 10 - Tape Reader Trip Lever

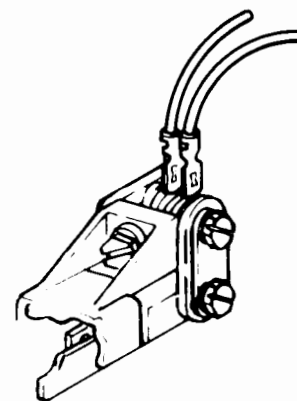

Figure 11 - Feed Magnet Contacts

G. Tape Feed Mechanism

3.12 The tape feeding cycle begins when the feed magnet attracts the armature as described in 3.09. The right armature extension has a feed pawl attached to it which engages a tooth on the feed ratchet when the armature extensions rise (Figure 8). Before the feed pawl can be pulled down to advance the feed wheel one character a series of steps take place as follows.

3.13 If the control lever is held in the START position, the distributor clutch trip coil will remain energized (Figure 9).

3.14 Near the beginning of the stop pulse the camming surface on the reader trip lever rides the camming roller on the distributor shaft and overtravels the trip coil armature (Figure 10).

3.15 The feed magnet contacts open momentarily causing the feed magnet in the reader mechanism to be de-energized (Figure 11).

3.16 With the feed magnet de-energized the armature extensions drop, withdrawing the sensing pin guide and the sensing pins (Figure 12).

3.17 The tape reader trip lever is not latched due to the energized trip coil, and therefore, the distributor clutch does not disengage. The tape reader trip lever, once again, closes the feed magnet contacts by means of the insulator. The projection moves the distributor clutch stop bail which in turn keeps the distributor clutch trip lever away from the shoe lever, allowing the clutch to continue its rotation.

3.18 Tape feeding will occur at the same time that the sensing pins are withdrawn. As the armature extensions drop the pawl advances the feed ratchet one tooth (Figure 13). Associated with the feed ratchet are also a detent lever and a blocking pawl.

3.19 The detent lever, with its circular surface engaging the feed ratchet teeth, holds the feed ratchet and the feed wheel in its correct position during sensing (Figure 13).

3.20 The blocking pawl, which rides a post on the feed pawl, is lowered into engagement with a feed ratchet tooth during the feed stroke. This is to prevent excessive overthrow of the feed wheel during feeding, without the use of a

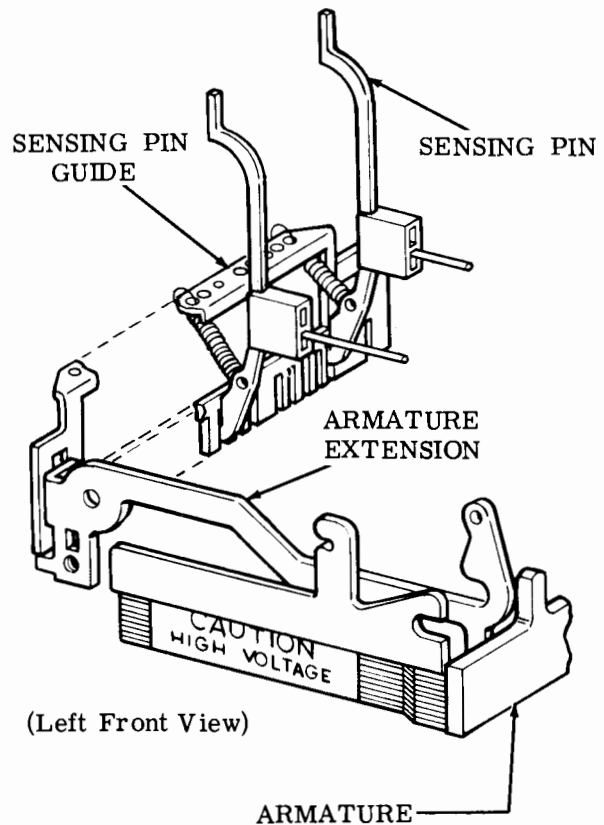

Figure 12 - Sensing Pin Guide

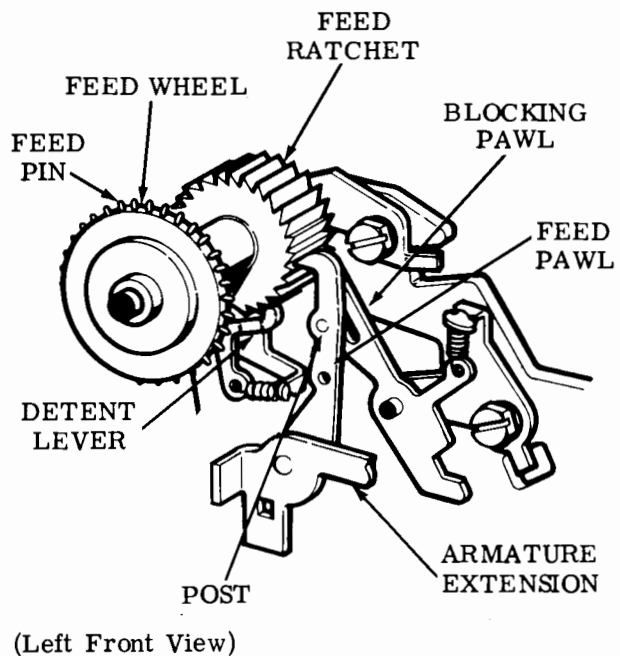

Figure 13 - Tape Feed Mechanism

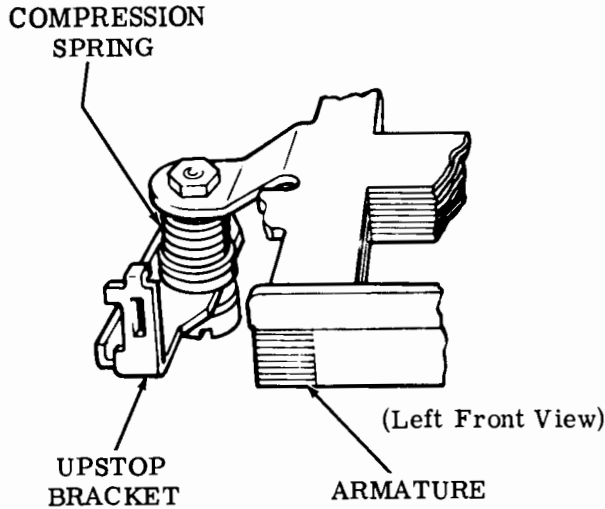

Figure 14 - Upstop Mechanism

heavy detent spring. It also prevents the pulling ahead of the tape, during sensing, by a tape winder, without the use of a heavy detent spring. During the upstroke of the armature extensions, the blocking pawl is rotated out of engagement with the tooth by the post on the feed pawl (Figure 13).

H. Upstop Mechanism

3.21 The armature is provided with a spring biased upstop which serves two purposes.

- (a) A portion of the energy during the end of the stroke is stored in a spring and returned to the armature on the downstroke to give a rapid release and acceleration.
- (b) A portion of the energy is dissipated through a resilient buffer to minimize noise and metallic clatter (Figure 14).

4. FEATURES

MANUAL READER

A. Freewheeling Mechanism (Figure 15)

4.01 The 33 tape reader is provided with a freewheeling feature which allows the feed wheel to rotate freely. When the control lever is moved to the FREE position, the extension on the control lever engages the blocking pawl and pivots it clockwise. Riding in a slot on the underside of the blocking pawl is a stud which connects to the feed pawl. As the blocking pawl

is pivoted clockwise by the control lever extension, the blocking pawl moves the feed pawl away from the feed ratchet. With the feed ratchet free, the feed wheel will also rotate freely.

B. Tight-Tape Mechanism (Figure 16)

4.02 This feature consists of a plastic tight-tape bail which snaps into the tape lid. The tight-tape bail serves to turn the tape reader OFF when the moving tape becomes taut. The tight-tape bail has an extension on it which projects through the top plate. This extension rides on a spring biased tight-tape lever. If the tape in the tape reader becomes taut, the bail will be lifted. The bail extension will rotate, causing the tight-tape lever to rotate also. In its pivoting motion the tight-tape lever will lift the tight-tape contact wires away from the contact terminal, breaking the current path. With the circuit broken the tape reader stops.

C. Tape-Out Mechanism (Figure 17)

4.03 The tape reader is equipped with a tape-out feature which will stop the tape reader when the tape runs out. A tape-out pin protrudes above the surface of the top plate. During tape sensing the tape-out pin is kept depressed by the moving tape. When the tape runs out, the spring biased tape-out pin moves fully up. An

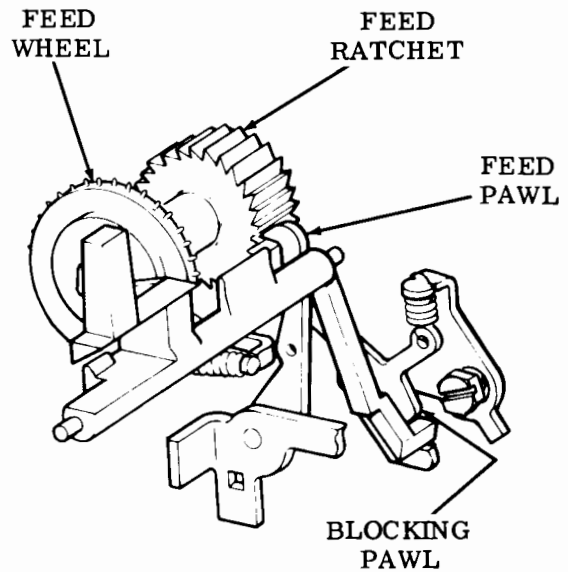

(Left Front View)

Figure 15 - Freewheeling Mechanism

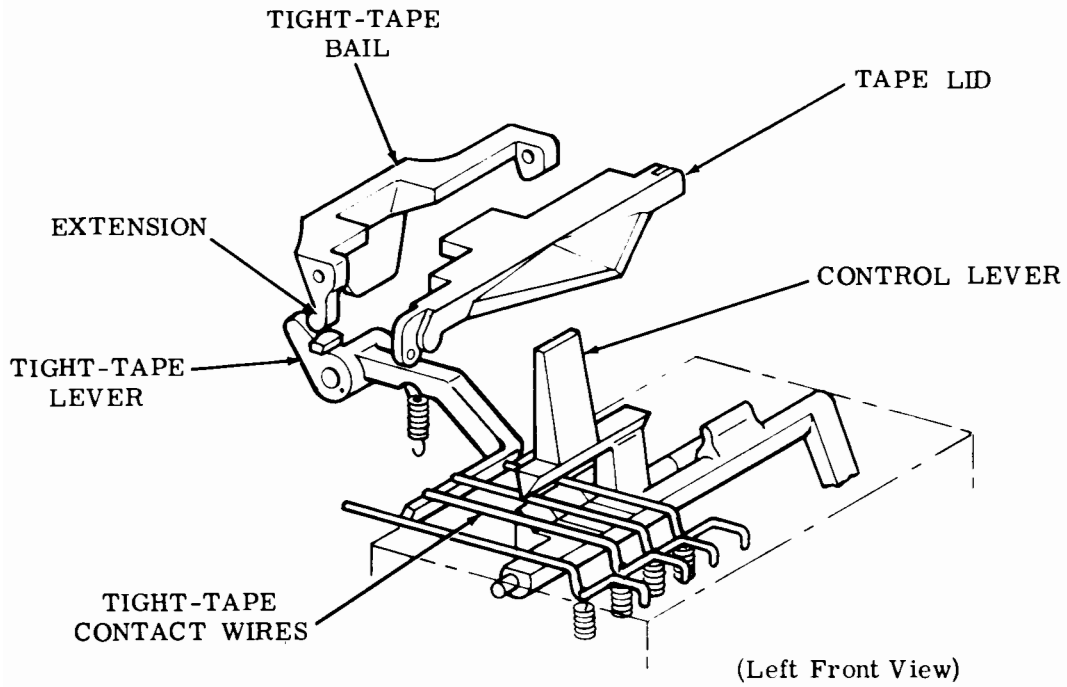

Figure 16 - Tight-Tape Mechanism

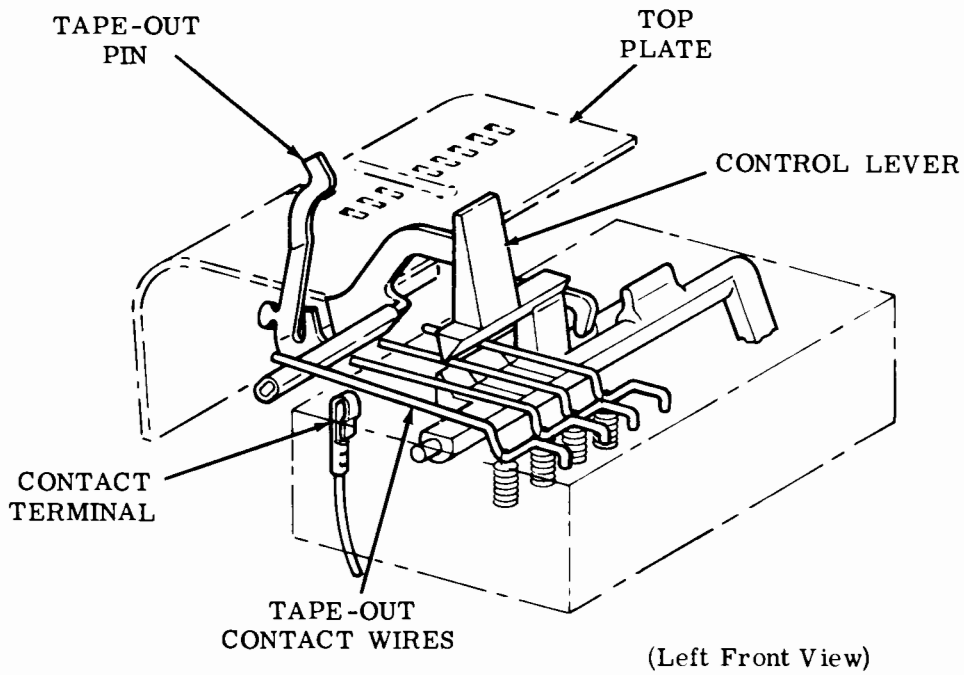

Figure 17 - Tape-Out Mechanism

insulated extension on the tape-out pin lifts the tape-out contact wires away from the contact terminal. This breaks the current path and the tape reader stops.

AUTOMATIC CONTROL FEATURES

4.04 The automatic control features allow the tape reader to be started or stopped either manually or automatically. This is accomplished by means of additional contacts, a relay, and wiring. There are other contacts in the typing unit function area and, for sprocket feed typing units, in the form out mechanism, which are related with the tape reader automatic features.

A. Local Start (Figure 18)

4.05 When the control lever is placed in the MANUAL START position the following events take place:

- (a) The start contact wires close momentarily.
- (b) After closing momentarily the start contact wires are opened due to the detent action of the control lever.

- (c) The momentary closing of the start contact wires energizes the relay and two normally open contacts associated with the relay.
- (d) The first relay contact closes a holding circuit.
- (e) The second relay contact — if there is tape in the tape reader and the tape-out contact is closed — closes the circuit to the distributor clutch. The distributor clutch will then be tripped as explained in 3.08.

B. Remote Start (Figure 19)

4.06 When the control lever is placed in the AUTO position, the start contact is open and the stop contact is closed. The tape reader will respond to a remote reader start signal and turn ON automatically. The remote signal will close a contact in the typing unit function area and complete an electrical path to the distributor area.

C. Reader Stop

4.07 When the control lever is placed in the MANUAL STOP position, the stop contact wires are momentarily opened, de-energizing

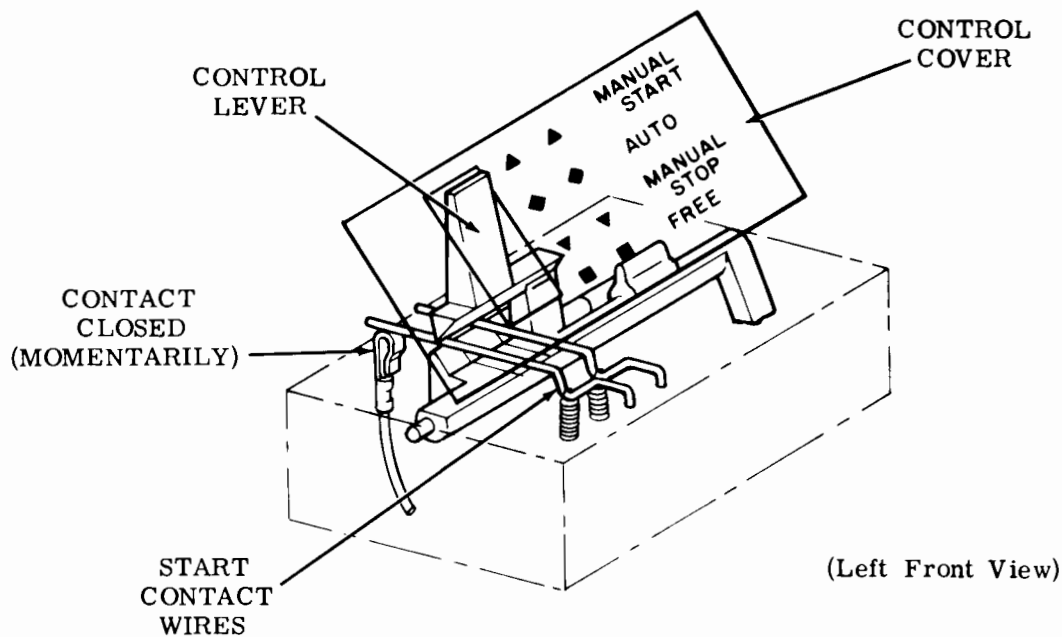

Figure 18 - MANUAL START Position

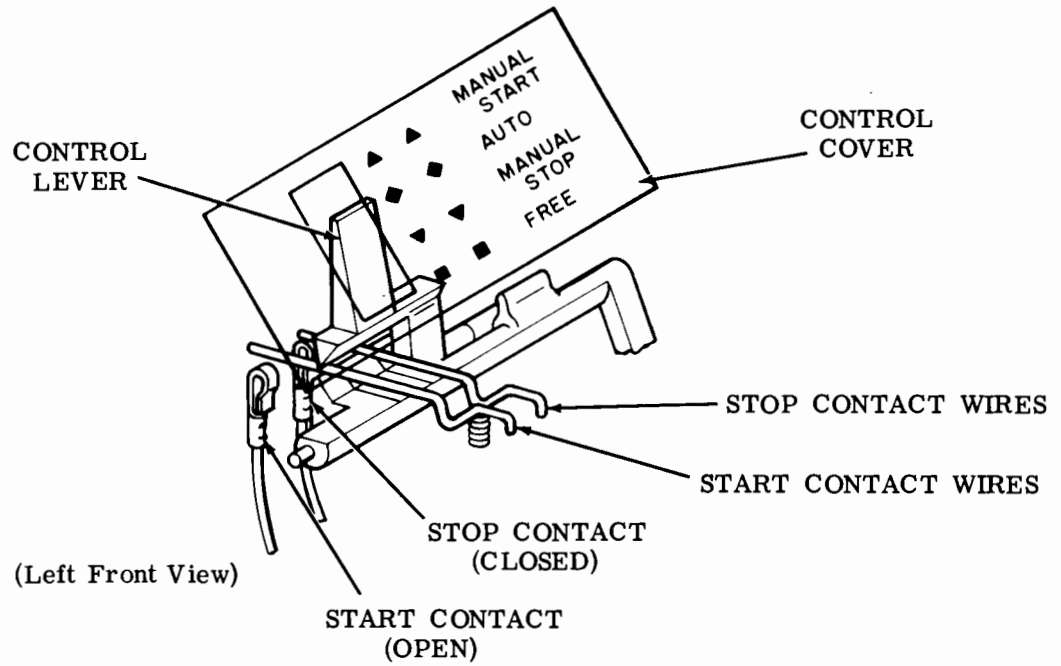

Figure 19 - Automatic Start Position

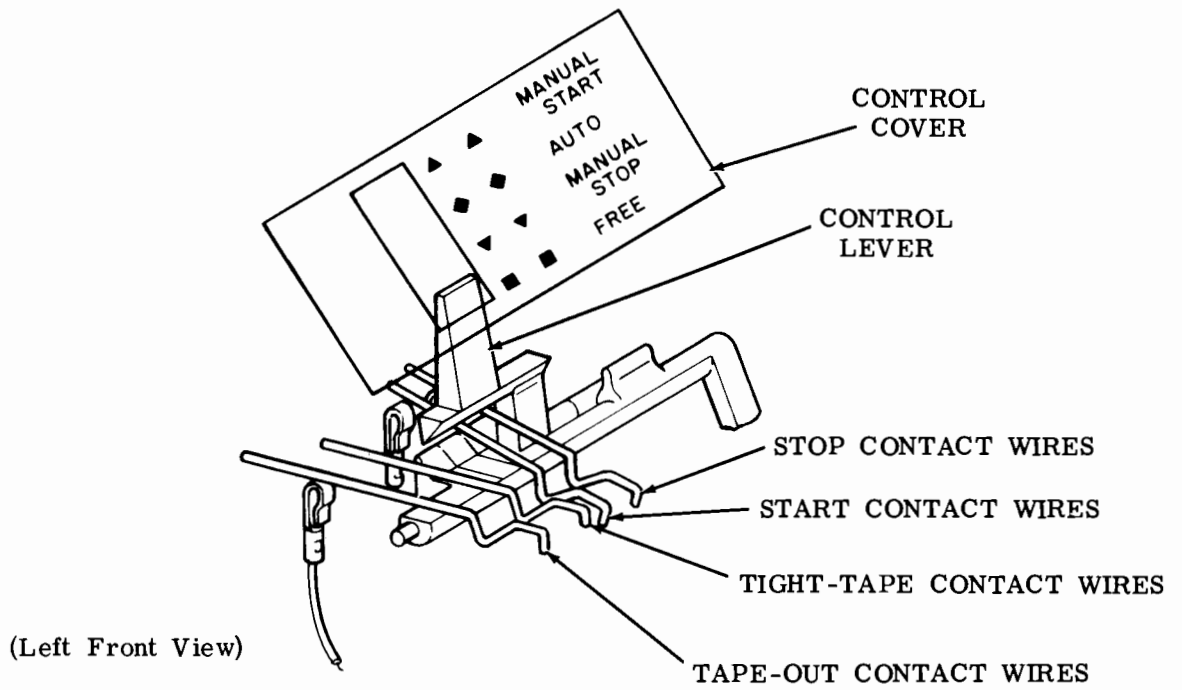

Figure 20 - Control Lever in FREE Position

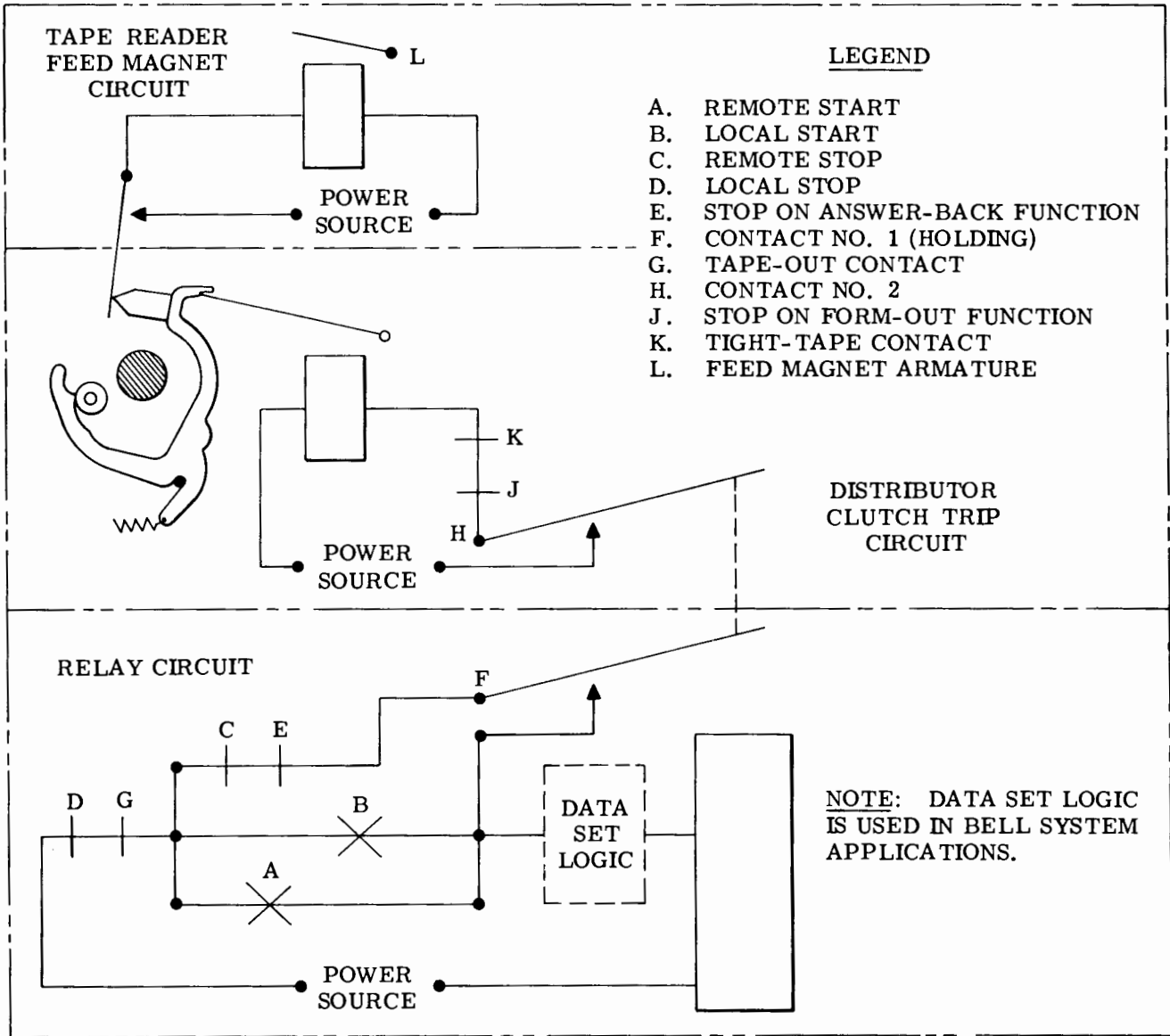

Figure 21 - Automatic Reader Control Schematic

the relay and opening two relay contacts. One of these contacts opens the reader trip magnet circuit. The trip magnet de-energizes causing the tape reader to stop.

Alternate Reader Stop

4.08 The automatic tape reader can be stopped either permanently or temporarily. When the reader is stopped permanently it cannot be started again automatically but must be started manually. When temporarily stopped, the reader can be started again either automatically or manually.

Permanent Stop

4.09 Besides the stop contact wires mentioned in 4.07, the following are normally closed contacts wired in series with the relay in the power pack:

- (a) Tape-out contact wires
- (b) Tape reader OFF function box contact
- (c) WRU function box contact

When one of these contacts is momentarily opened, the relay is de-energized, opening two relay contacts. One of these relay contacts

opens the reader trip magnet circuit. The trip magnet de-energizes causing the reader to stop permanently.

Temporary Stop

4.10 The following normally closed contact wires are wired in series with the reader trip magnet:

- (a) Form-out function box contact
- (b) Tight-tape contact wires

When one of these contacts is opened the trip magnet is de-energized stopping the tape reader temporarily.

D. FREE Position (Figure 20)

4.11 When the control lever is placed in the FREE position the start and stop contacts are open. The tape reader will not respond to a remote reader start signal.

33 TAPE READER

LUBRICATION

CONTENTS	PAGE
1. GENERAL	1
2. BASIC UNIT	2
Armature shaft	4
Clutch trip area	6
Control mechanism	5
Distributor clutch trip magnet	7
Feed pawl mechanism	5
Feed wheel	4
Reader feed magnet contact	7
Reader trip lever	8
Tape lid mechanism	6
Tape reader	2
Tape reader mechanism	3
Tight tape mechanism	4

LUBRICATION INTERVALS IN WEEKS
 BASED ON 5-DAY WEEK (Note 1)

NEWLY INSTALLED EQUIPMENT			
	DAILY USE		
SPEED	0 to 8 Hours	8 to 16 Hours	16 to 24 Hours
All Speeds	3 Weeks	2 Weeks	1 Week

REGULAR LUBRICATION			
	DAILY USE		
SPEED	0 to 8 Hours	8 to 16 Hours	16 to 24 Hours
60 WPM	39 Weeks	26 Weeks	13 Weeks
100 WPM	26 Weeks	13 Weeks	6 Weeks

1. GENERAL

1.01 This section provides lubrication requirements for the 33 tape reader. It is reissued to add new lubrication interval requirements for the tape reader. Marginal arrows indicate changes and additions.

1.02 The general lubrication areas are illustrated by photographs. The specific points to receive lubricant are indicated on line drawings with appropriate textual instructions. Line drawings and textual instructions follow each photograph and are keyed to the photograph by paragraph numbers.

1.03 Thoroughly lubricate the tape reader, but avoid over lubrication that might permit the lubricant to drip or be thrown onto adjacent parts. Saturate all felt washers.

1.04 Initial lubrication of the tape reader should be completed just prior to placing it into service. The lubrication intervals for the tape reader are similar to the lubrication intervals of the set. The lubrication intervals are dictated by the hours of use (including idle time) on a daily basis. The following charts and notes list the appropriate lubrication intervals.

Note 1: Reduce lubrication interval 15 percent when usage is 6 days per week, 30 percent when usage is 7 days per week.

Note 2: Sets operating at speeds between 60 and 100 wpm use lubrication requirements for the lower of the two speeds.

Note 3: The lubrication intervals are for the set as a whole — all components of the set should be lubricated.

Note 4: Just prior to storage, all equipment should be thoroughly lubricated.

1.05 The textual instructions that accompany the line drawings consist of abbreviated directions, specific lubrication points,

SECTION 574-124-701TC

and parts affected. The meanings of the abbreviated directions (symbols) are given below:

<u>Symbol</u>	<u>Meaning</u>
D	Keep dry — no lubricant permitted.
G	Apply thin coat of KS7471 grease.
L	Apply thin coat of Lubriplate 105 (2 oz tube TP108805).
O	Oil (KS7470 oil).

1.06 References to left, right, front, or rear, etc, consider the tape reader to be viewed from a position where the feed wheel faces up and the lid latch is to the viewer's right. Orientation references in the clutch trip area consider the armature extension to be facing up with the contact bracket pry points located to the viewer's right.

2. BASIC UNIT

2.01 Tape Reader

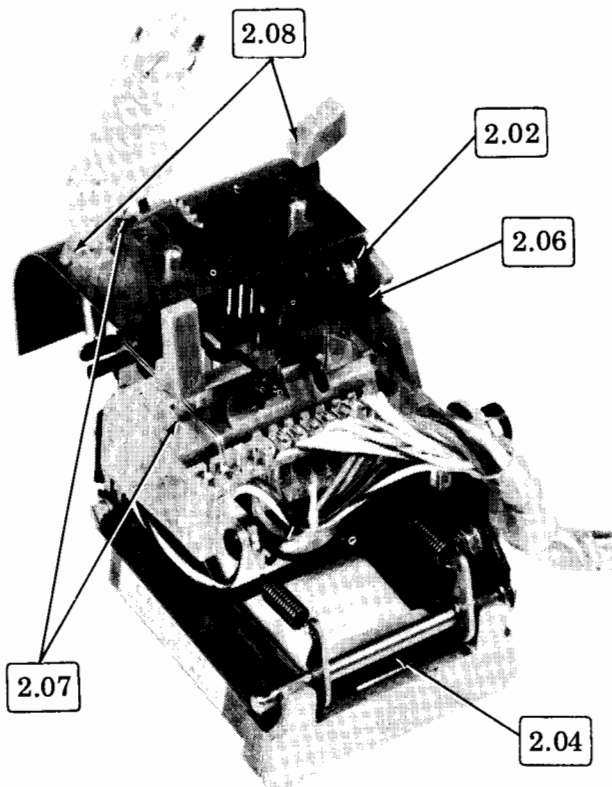

(Left Front View)

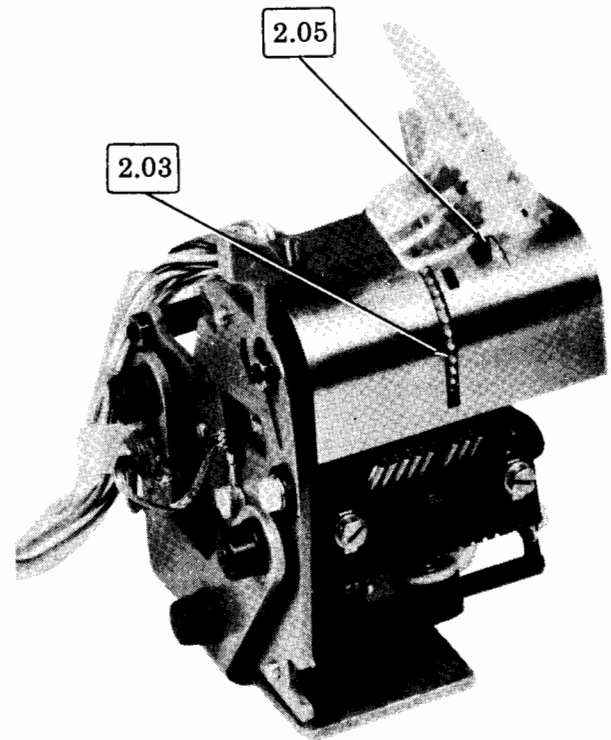

(Right Rear View)

CAUTION: DO NOT USE ALCOHOL, MINERAL SPIRITS, OR OTHER SOLVENTS TO CLEAN PLASTIC PARTS OR PARTS WITH PROTECTIVE, DECORATIVE FINISHES. NORMALLY, A SOFT, DRY CLOTH SHOULD BE USED TO REMOVE DUST, OIL, GREASE OR OTHERWISE CLEAN PARTS OR SUB-ASSEMBLIES. A SOFT CLOTH DAMPENED WITH SOAP OR MILD DETERGENT MAY BE USED. RINSE WITH A SOFT, DAMP CLOTH AND BUFF WITH A SOFT, DRY CLOTH.

1.07 Materials needed for lubrication are listed in Section 570-005-800TC.

1.08 For disassembly and reassembly information, refer to Section 574-124-702TC.

CAUTION: REMOVE ALL ELECTRICAL POWER FROM UNIT BEFORE LUBRICATING OR DISASSEMBLING COMPONENTS.

2.02 Tape Reader Mechanism

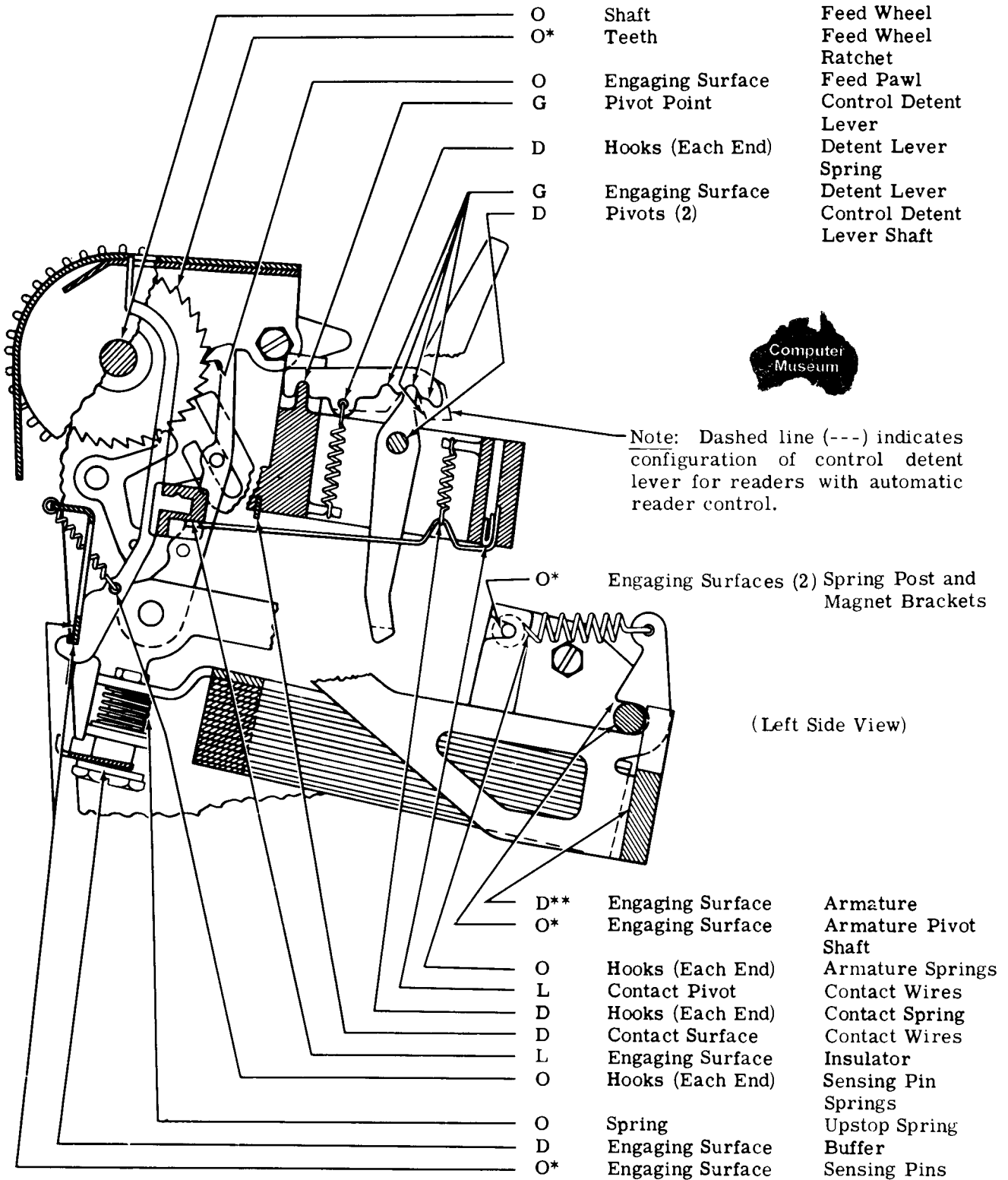

*At 1500 hour lubrication intervals, apply with a coat of thoroughly mixed 50 percent KS7470 oil and 50 percent KS7471 grease.

**Some oil leakage on this surface is permissible.

SECTION 574-124-701TC

2.03 Feed Wheel

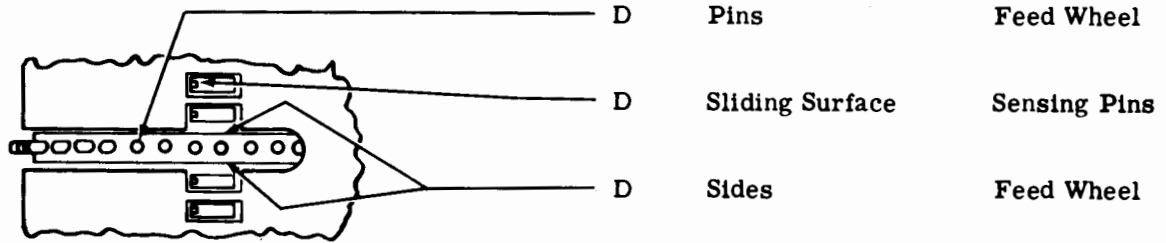

(Top View)

2.04 Armature Shaft

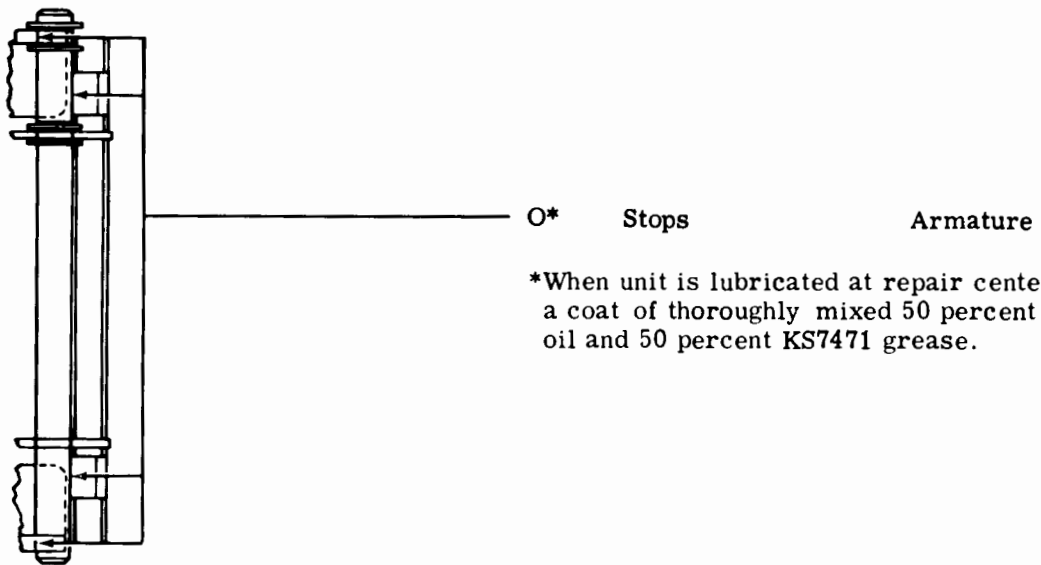

*When unit is lubricated at repair center, apply a coat of thoroughly mixed 50 percent KS7470 oil and 50 percent KS7471 grease.

(Top View)

2.05 Tight Tape Mechanism

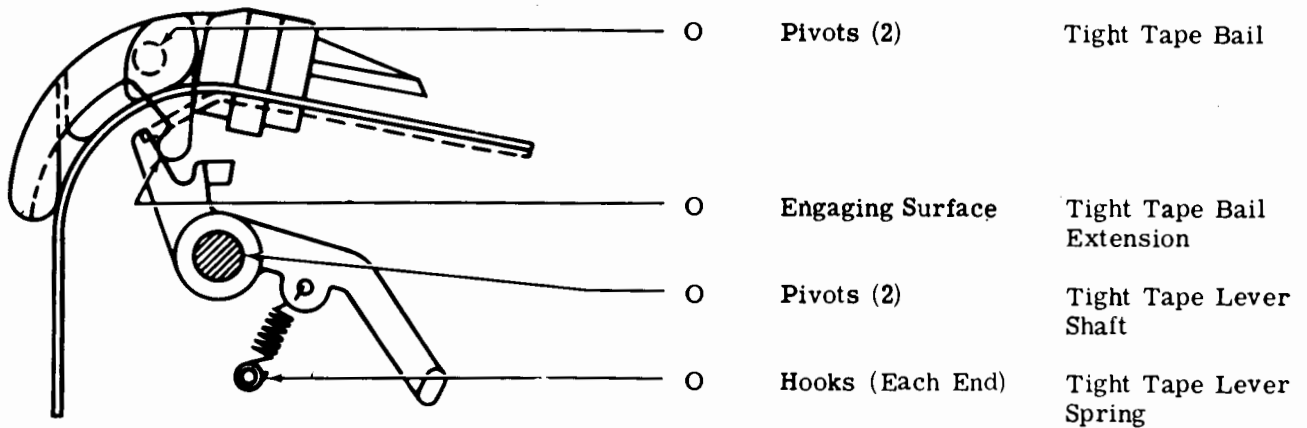

(Left Side View)

2.06 Feed Pawl Mechanism

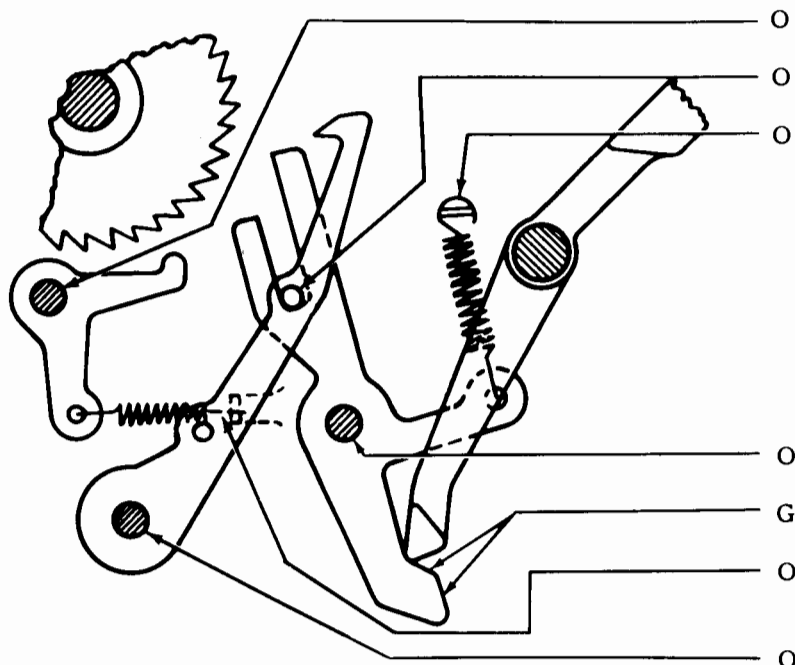

(Left Side View)

- | | | |
|---|------------------|----------------------|
| O | Pivot | Detent Lever Shaft |
| O | Pivot | Feed Pawl Stud |
| O | Hooks (Each End) | Blocking Pawl Spring |
| O | Pivot | Blocking Pawl |
| G | Engaging Surface | Blocking Pawl |
| O | Hooks (Each End) | Detent Lever Spring |
| O | Pivot | Feed Pawl |

2.07 Control Mechanism

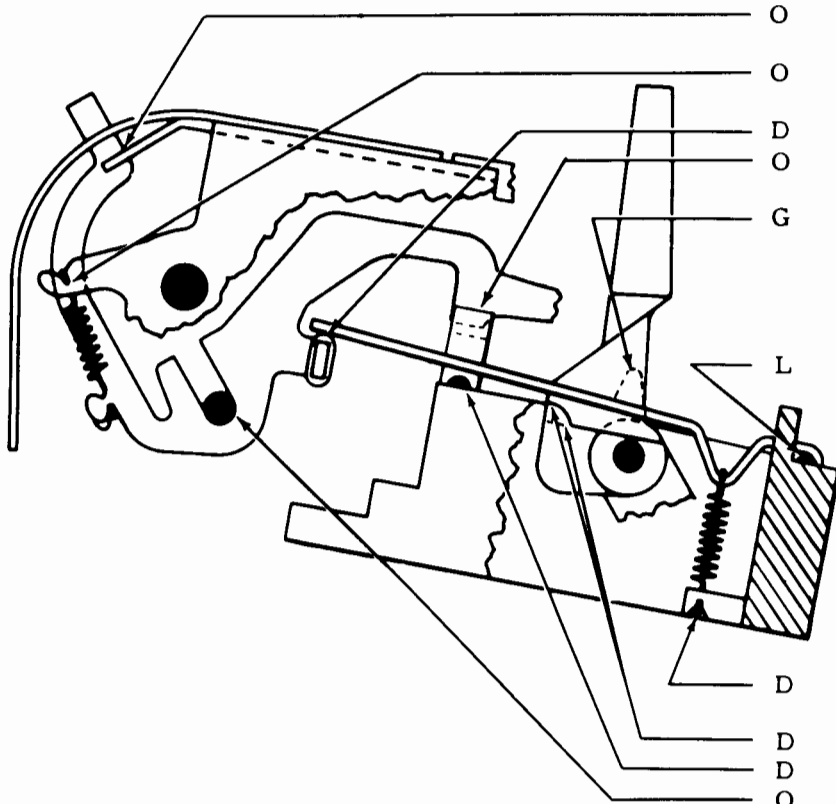

(Left Side View)

- | | | |
|---|------------------|------------------------|
| O | Sliding Surface | Tape-Out Pin Guide |
| O | Hooks (Each End) | Tape-Out Pin Spring |
| D | Engaging Surface | Insulator |
| O | Sliding Surface | Tape-Out Lever Guide |
| G | Camming Surface | Tape-Out Lever Cam |
| L | Pivot | Contact Wire |
| D | Hooks (Each End) | Contact Wire Springs |
| D | Camming Surface | Control Lever Terminal |
| D | Contact Surface | Tape-Out Lever |
| O | Pivot | |

2.08 Tape Lid Mechanism

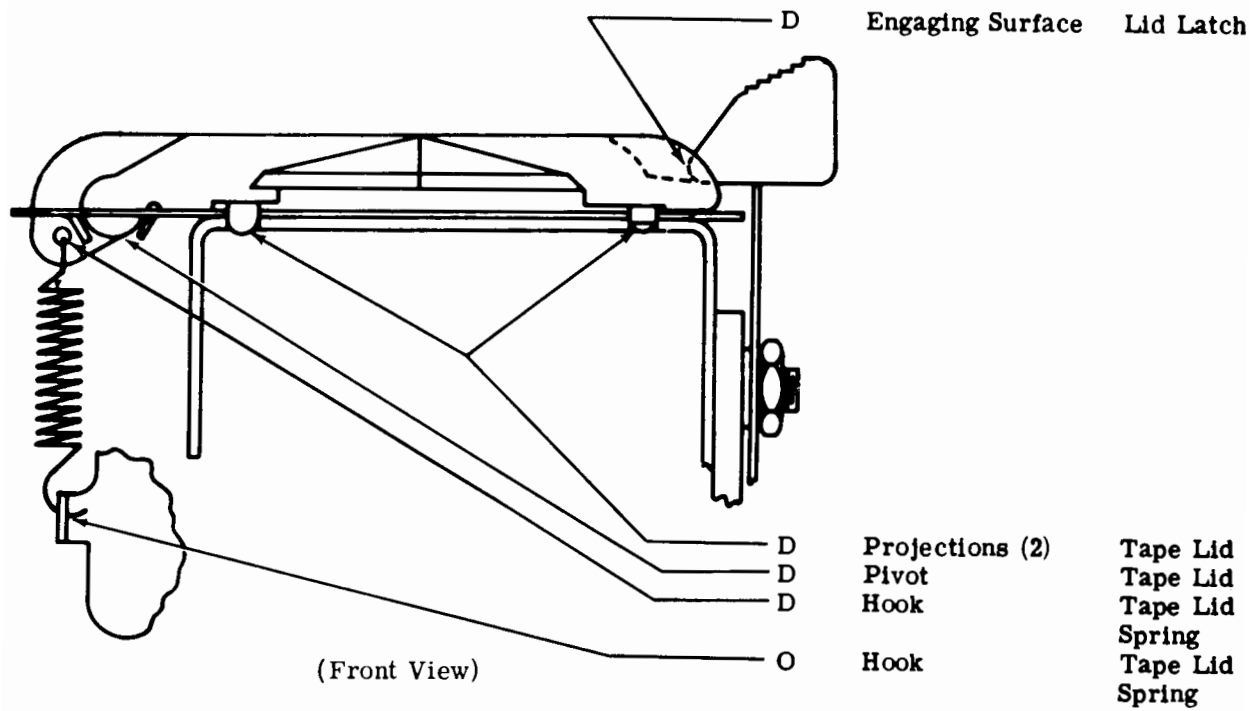

2.09 Clutch Trip Area

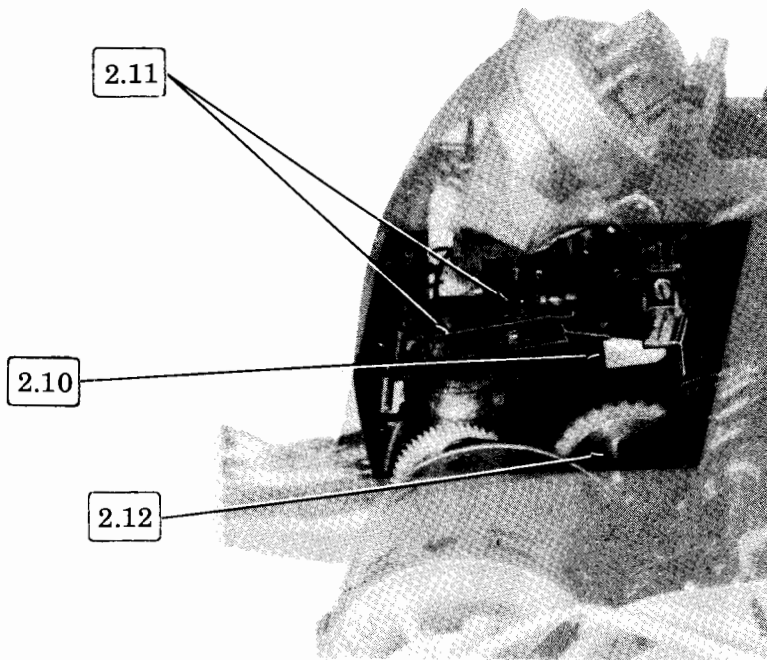

(Left Side View)

2.10 Reader Feed Magnet Contact

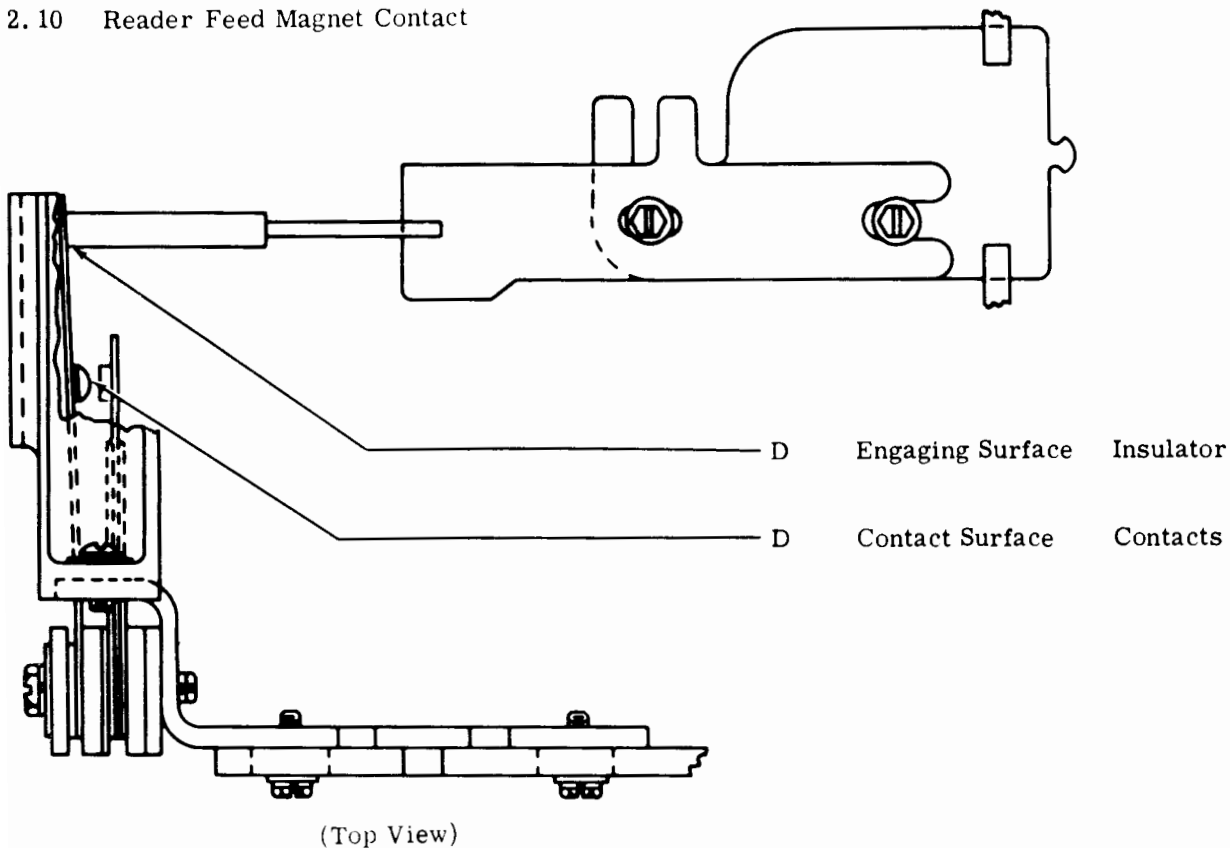

2.11 Distributor Clutch Trip Magnet

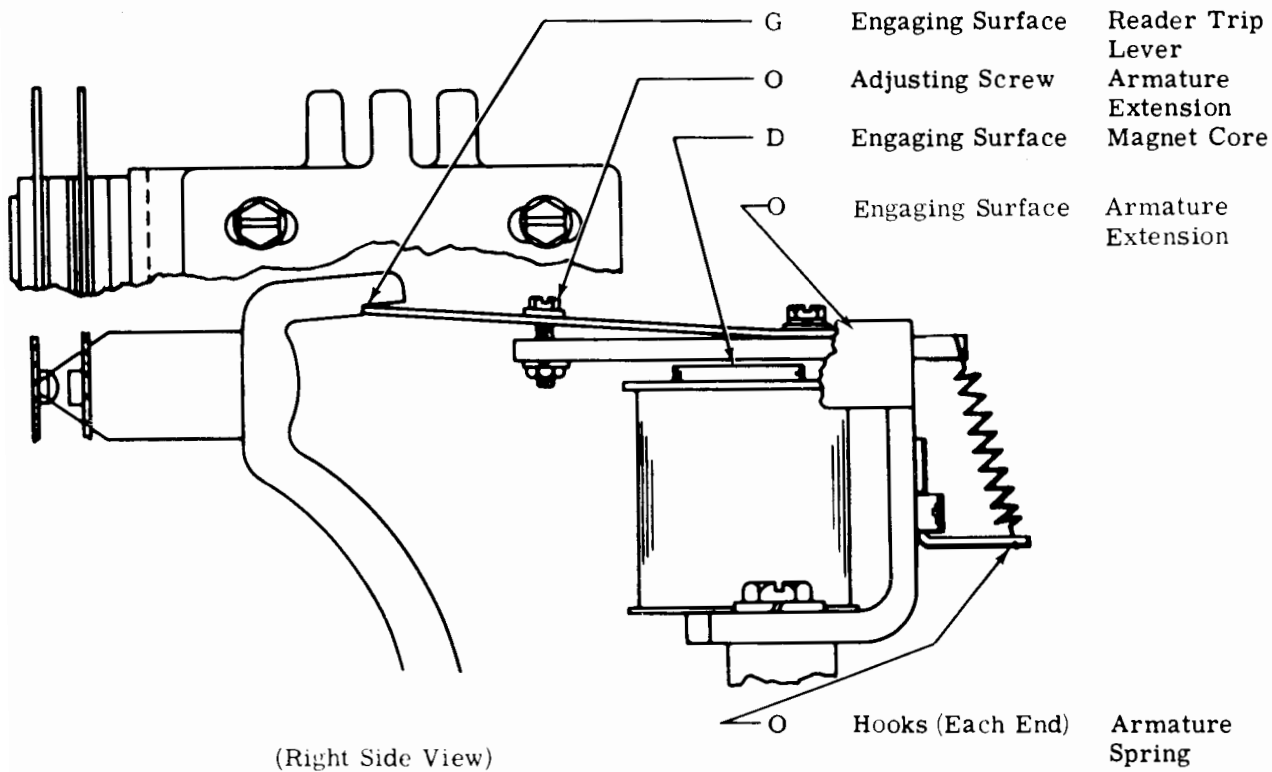

2.12 Reader Trip Lever

(Remove answer-back drum.)

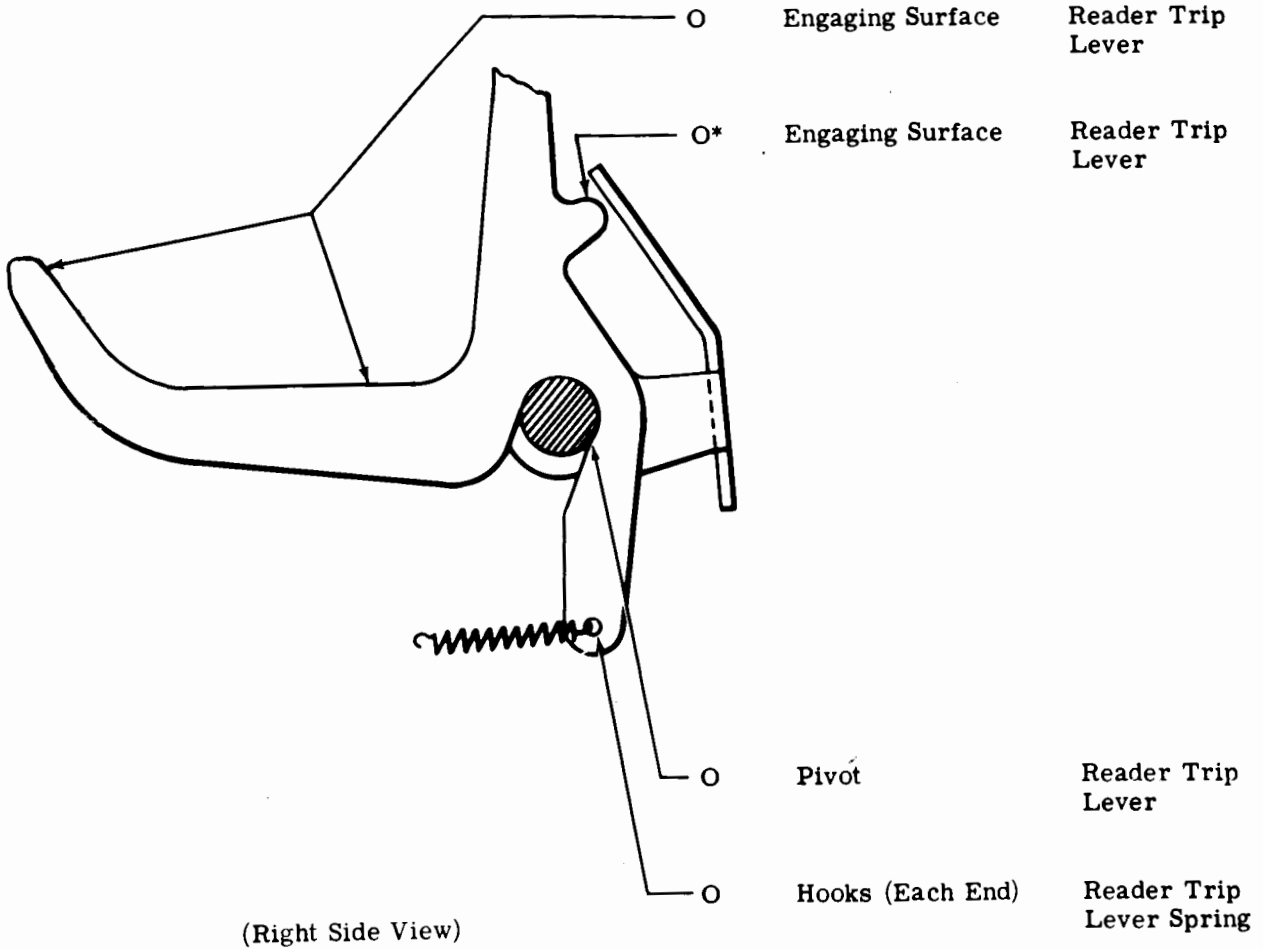

(Replace answer-back drum.)

*At 1500 hour lubrication intervals, apply a coat of thoroughly mixed 50 percent KS7470 oil and 50 percent KS7471 grease.

33 TAPE READER

DISASSEMBLY AND REASSEMBLY

CONTENTS	PAGE
1. GENERAL	1
2. DISASSEMBLY AND REASSEMBLY . .	1
SENSING PIN ASSEMBLY	1
FEED MAGNET ASSEMBLY	1
FEED WHEEL AND TOP PLATE ASSEMBLY	2
TAPE READER FEED MAGNET CONTACT	2
TAPE READER CLUTCH TRIP MAGNET ASSEMBLY	3

1. GENERAL

1.01 This section is reissued to incorporate recent engineering changes and to present disassembly and reassembly information exclusively for 33 tape readers. Since this is a general revision, marginal arrows, used to indicate changes, have been omitted.

1.02 References to left, right, front, rear, etc, consider the tape reader to be viewed from a position where the feed wheel faces up and the lid latch is to the viewer's right.

1.03 Disassembly, as outlined in this section, covers the procedure for removing the principle subassemblies which make up the unit. If further disassembly is required, refer to the appropriate illustrated parts section which shows detailed arrangements of parts. Where it will help in determining location, the numbers of the parts are given in the instructions.

1.04 All tools used to remove the various assemblies referred to in this section can be found in the standard tool section 570-005-800TC.

1.05 All damaged, worn, or distorted parts should be replaced if encountered in the disassembly and reassembly procedures.

2. DISASSEMBLY AND REASSEMBLY

Note: For information concerning the proper procedure to remove the tape reader and associated cable assemblies from the set, refer to appropriate set disassembly and reassembly section.

SENSING PIN ASSEMBLY

2.01 To remove the sensing pin assembly (Figure 2), proceed as follows.

(a) Remove the two TP151152 mounting screws, TP110743 lockwashers, and TP104807 flat washers which mount the TP183035 sensing pin guide.

(b) Remove sensing pin assembly.

(c) To replace sensing pin assembly, reverse procedure used to remove it.

FEED MAGNET ASSEMBLY

2.02 To remove the feed magnet assembly (Figure 1), proceed as follows.

(a) Remove contact block assembly.

(b) Remove sensing pin assembly.

(c) Unhook the TP90517 detent lever spring from the TP183023 detent bracket.

(d) Unhook the TP114107 blocking pawl spring from the TP183020 blocking pawl bracket.

(e) Remove the TP151152 magnet bracket mounting screw, the TP110743 lockwasher, and the TP104807 washer. Then, remove the two TP181241 magnet bracket mounting screws.

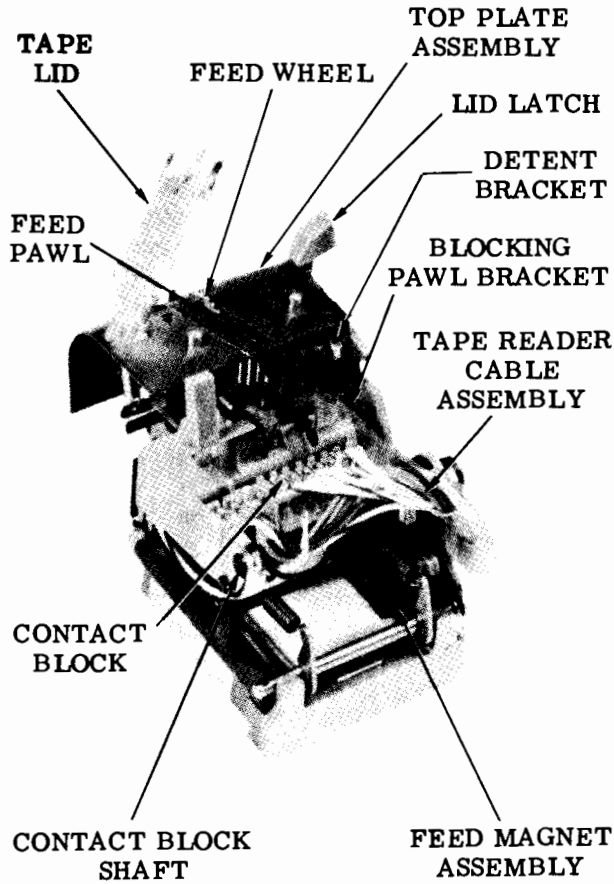

(Left Front View)

Figure 1 - Tape Reader (Without Cover)

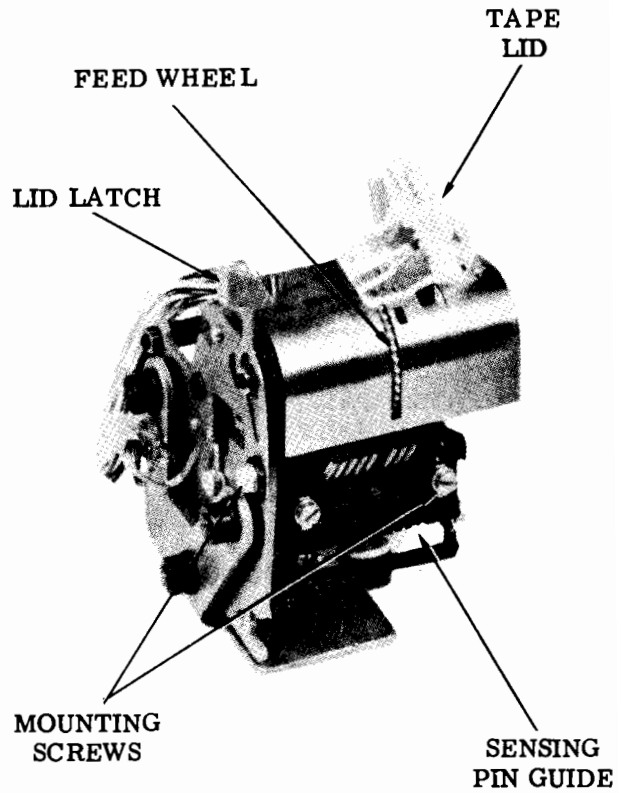

(Right Rear View)

Figure 2 - Tape Reader (Without Cover)

- (f) Slide the TP183011 feed pawl stud out of engagement with the TP183016 blocking pawl.
- (g) Remove feed magnet assembly.
- (h) To replace feed magnet assembly, reverse procedure used to remove it.

FEED WHEEL AND TOP PLATE ASSEMBLY

2.03 To remove feed wheel and top plate assembly (Figure 1), proceed as follows.

- (a) Remove contact block and cable assembly.
- (b) Remove sensing pin assembly.

- (c) Remove the TP182139 feed magnet assembly.
- (d) Unlatch the TP183032 tape lid.
- (e) Remove the TP181241 detent bracket mounting screw and TP3598 feed wheel shaft nut and TP124177 lockwasher.
- (f) Remove feed wheel and top plate assembly.
- (g) To replace feed wheel and top plate assembly, reverse procedure used to remove it.

TAPE READER FEED MAGNET CONTACT

2.04 To remove the tape reader feed magnet contact (Figure 3), proceed as follows.

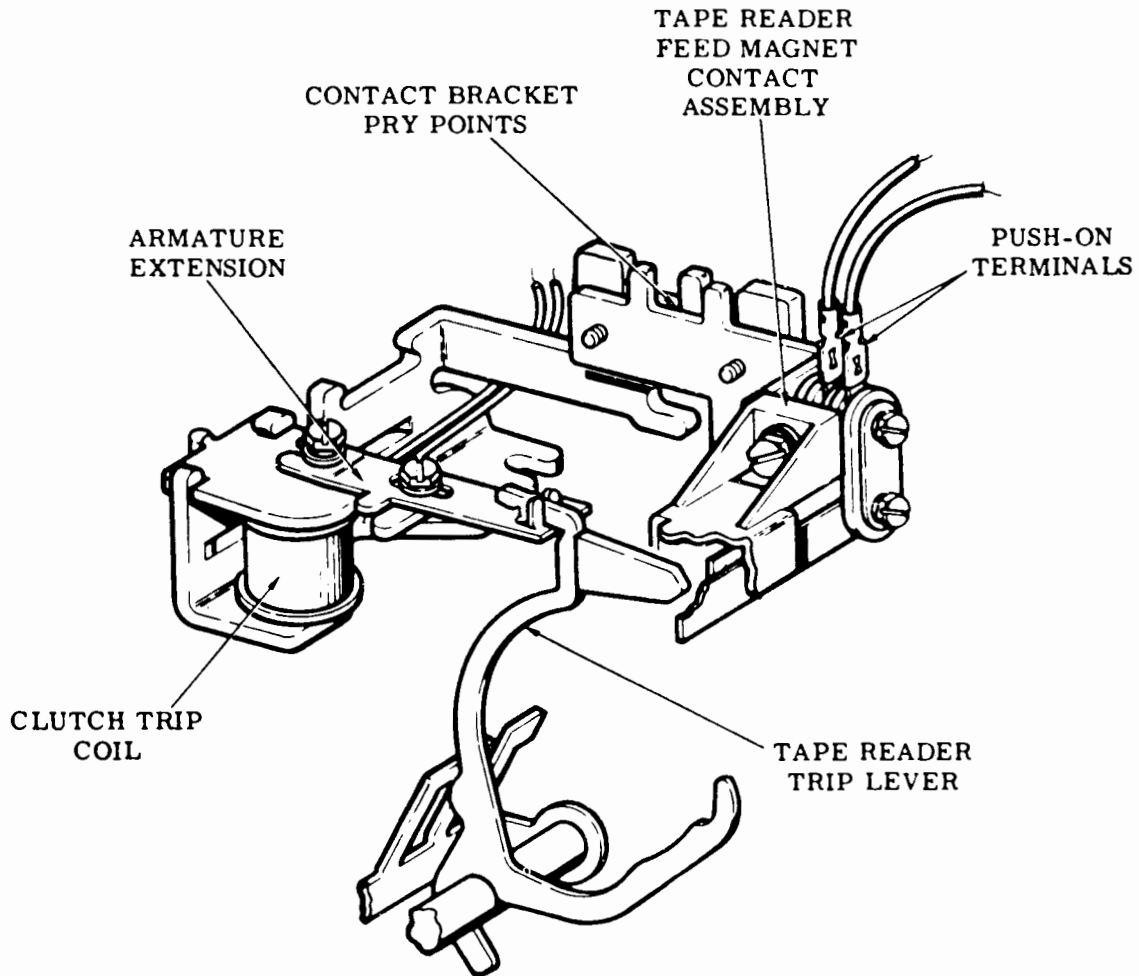

Figure 3 - Clutch Trip Magnet Assembly

- (a) Remove the two push-on TP182726 terminals of the tape reader cable.
- (b) Remove the two TP152893 tape reader feed magnet mounting screws, two TP104807 flat washers, and two TP110743 lockwashers.
- (c) Remove the tape reader feed magnet contact assembly.
- (d) To replace the tape reader feed magnet contact assembly, reverse procedure used to remove it.

TAPE READER CLUTCH TRIP MAGNET ASSEMBLY

- 2.05 To remove tape reader clutch trip magnet assembly (Figure 3), proceed as follows.

- (a) Remove the tape reader feed magnet contact assembly.
- (b) Remove plug no. 4 and, with extractor tool TP182697, remove terminals no. 11 and 12.
- (c) Loosen the two TP180989 distributor disc mounting screws and the TP180798 magnet bracket mounting screw.
- (d) Remove tape reader clutch trip magnet assembly.
- (e) To replace tape reader clutch trip magnet assembly, reverse procedure used to remove it.

33 TAPE PUNCH

GENERAL DESCRIPTION AND PRINCIPLES OF OPERATION

CONTENTS	PAGE
1. GENERAL	1
2. TECHNICAL DATA	2
3. DETAILED OPERATION	2
DRIVE MECHANISM	4
INTELLIGENCE TRANSFER MECHANISM	4
TAPE FEED MECHANISM	6
TAPE GUIDE MECHANISM	7
PUNCH BLOCK MECHANISM	7
BACKSPACE MECHANISM	8
4. CONTROL FEATURES	8
MANUAL PUNCH	8
AUTOMATIC PUNCH	10

1.03 The manual punch is turned on or off manually. It has four pushbuttons: ON, OFF, B.SP. (Backspace), and REL. (Release).

1.04 The automatic punch can be turned on or off both manually and automatically. For manual operation these pushbuttons are present on the lid: ON, OFF, B.SP., REL. In automatic operation the tape punch will turn on upon receipt of the DC2 code and turn off upon receipt of the DC4 code.

1.05 There also are 33 Sets equipped with a manual/automatic punch, that is, the punch may be operated as a manual punch or as an automatic punch. The punch, as shipped from the factory, has two clips installed in slots A-0 and A-8 which enable the punch for manual operation. Removing the clips enables the punch for automatic operation. Refer to Figure 2 for positions of the A-0 and A-8 slots.

1. GENERAL

1.01 This section provides a general description and principles of operation for the 33 tape punch (see Figure 1). It is reissued to consolidate information and make some corrections in the section. Marginal arrows have been used to indicate the changes.

1.02 The 33 tape punch is an 8-level device which perforates paper tape according to ASCII (American National Standard Code for Information Interchange). The tape punch does not receive signals from a transmitting set directly but uses the coded arrangement of the typing unit codebars. The 33 tape punch is a generic title referring to two basic types of punches, a manual and an automatic punch.

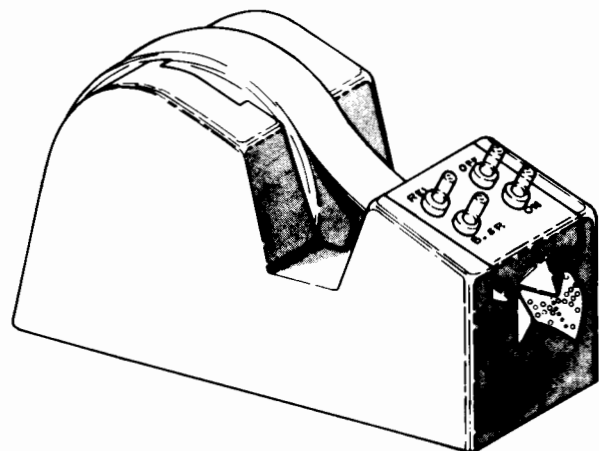

Figure 1 - 33 Tape Punch

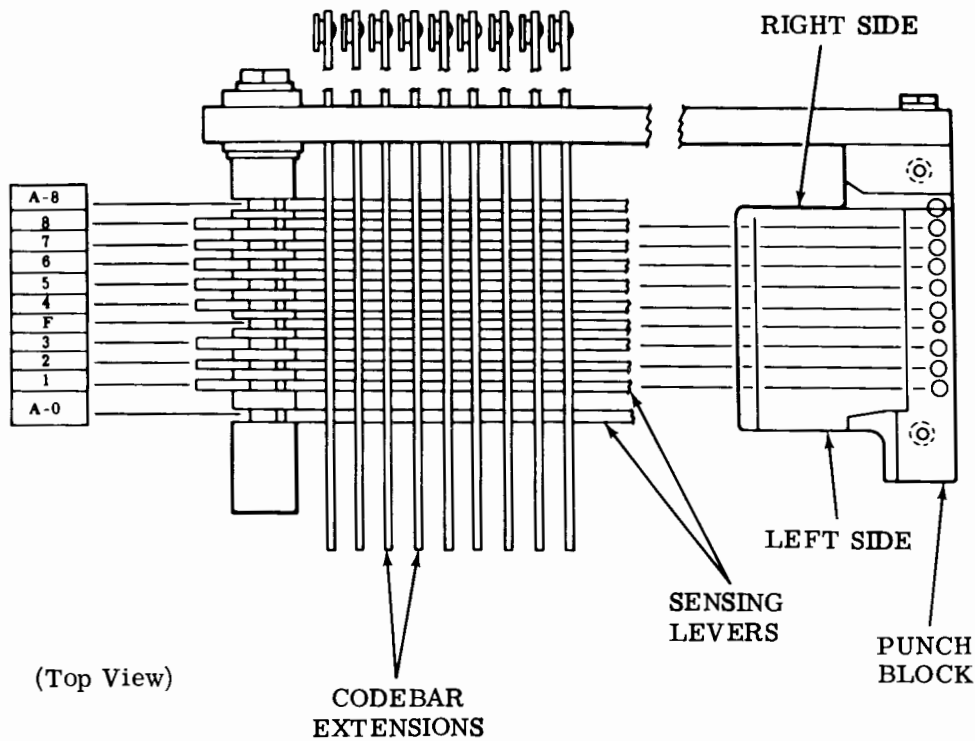

Figure 2 - Sensing Levers Slot Assignment

1.06 References to left, right, front, or rear, etc, consider the tape punch as viewed by the teletypewriter operator.

1.07 In the illustrations fixed pivots are solid black and floating points, those mounted on parts that move, are cross-hatched.

2. TECHNICAL DATA

Note: This equipment is intended to be operated in a room environment within the temperature range of 40°F to 110°F. Serious damage to it could result if this range is exceeded. In this connection, particular caution should be exercised in using acoustical or other enclosures.

2.01 Dimensions and Weight

Width 4 inches
 Height 6 inches
 Depth 6 inches
 Weight 21 ounces

2.02 Tape Specifications

Level 8 level
 Width 1 inch
 Code combination per inch 10
 Feed hole diameter 0.046 inch

2.03 Chad Box

Width 2 inches
 Length 6.5 inches
 Height 7.5 inches

2.04 The 33 tape punch is capable of operating at 60, 66, 75, or 100 words per minute.

3. DETAILED OPERATION

Note: The following paragraphs give a detailed description of the major mechanisms (Figure 3) in the punch. This description applies to the two punches mentioned in 1.02 thru 1.05. Control features peculiar to each punch will be discussed in Part 4.

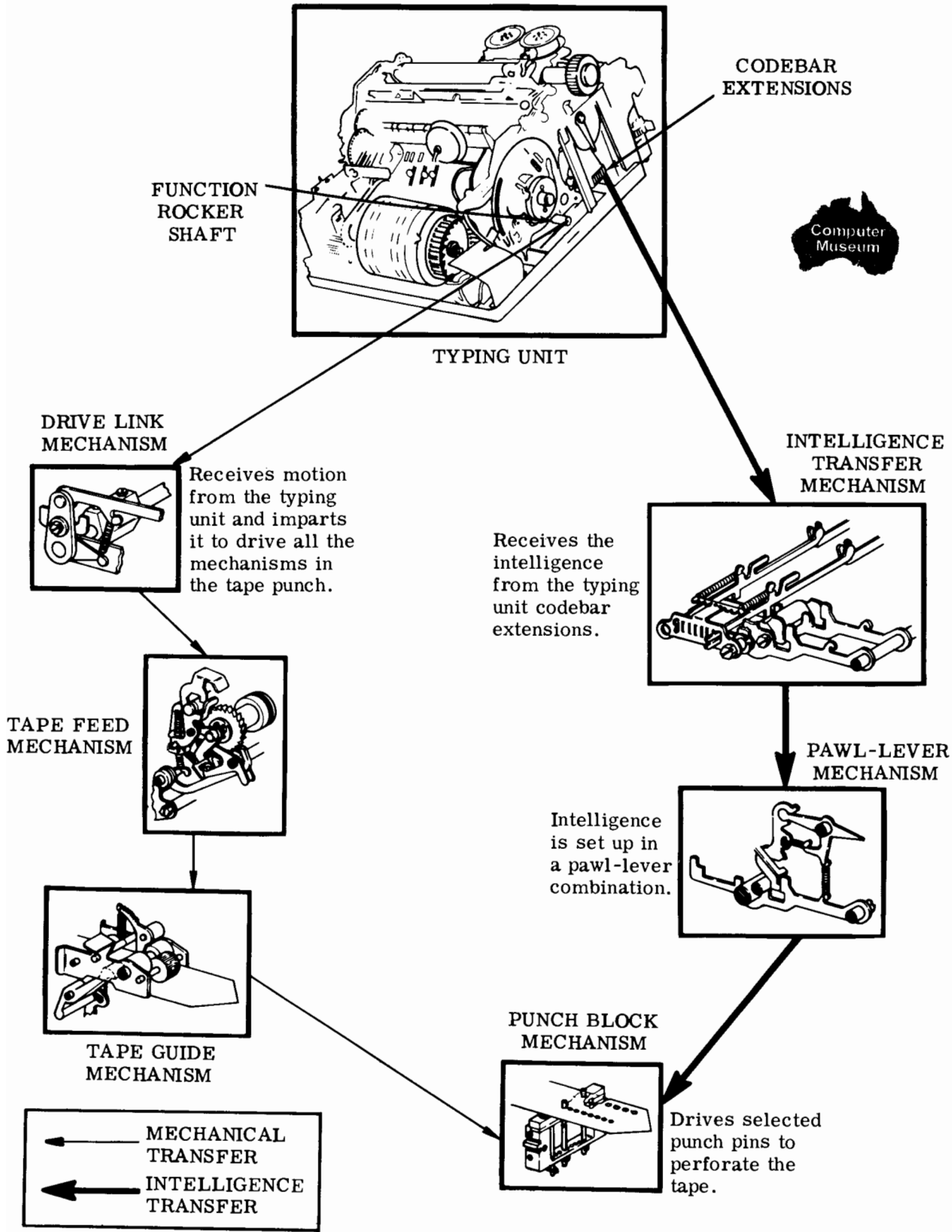

Figure 3 - Functional Diagram of the Tape Punch and Major Mechanisms

DRIVE MECHANISM

3.01 The rocking motion of the typing unit function rocker shaft is imparted to the tape punch by means of a sleeve which connects to a plate with shaft (Figure 4). A drive link, attached to the plate with shaft, connects to a drive post which simultaneously drives the nudger, feed pawl, and stripper bail, and supplies the downward force to pull the selected pawls by means of the sensing lever bail.

INTELLIGENCE TRANSFER MECHANISM

3.02 There is a codebar extension (Figure 5) for each typing unit codebar. Motion is imparted to the codebar extensions by the codebars through the typing unit reset bail. A plate mounted to the tape punch side frame guides the codebar extensions.

3.03 The typing unit selector blocking levers control the mark or space position of the codebars which, in turn, transfer this position to the codebar extensions. A blocked codebar represents a space; an unblocked codebar represents a mark.

3.04 Each codebar extension has a tab on its underside which lines up with its respective sensing lever, pawl, lever, and punch-pin combination.

3.05 During the drive mechanism's counter-clockwise travel, the sensing levers, under spring tension, move up and sense the codebar extensions. Each sensing lever, except the feed lever, has a tab on its top side which lines up with its respective codebar extension.

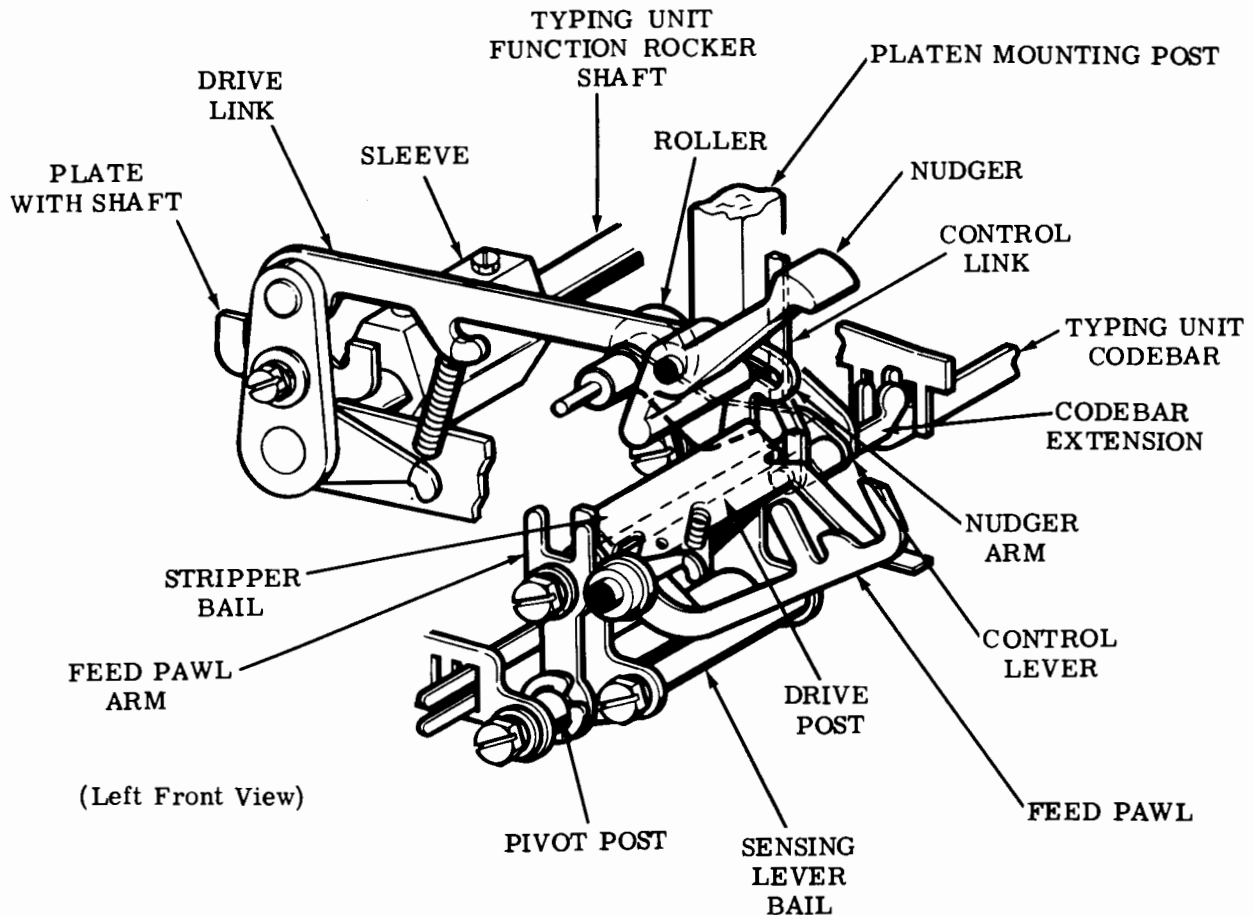

Figure 4 - Drive Link Mechanism and Drive Mechanism

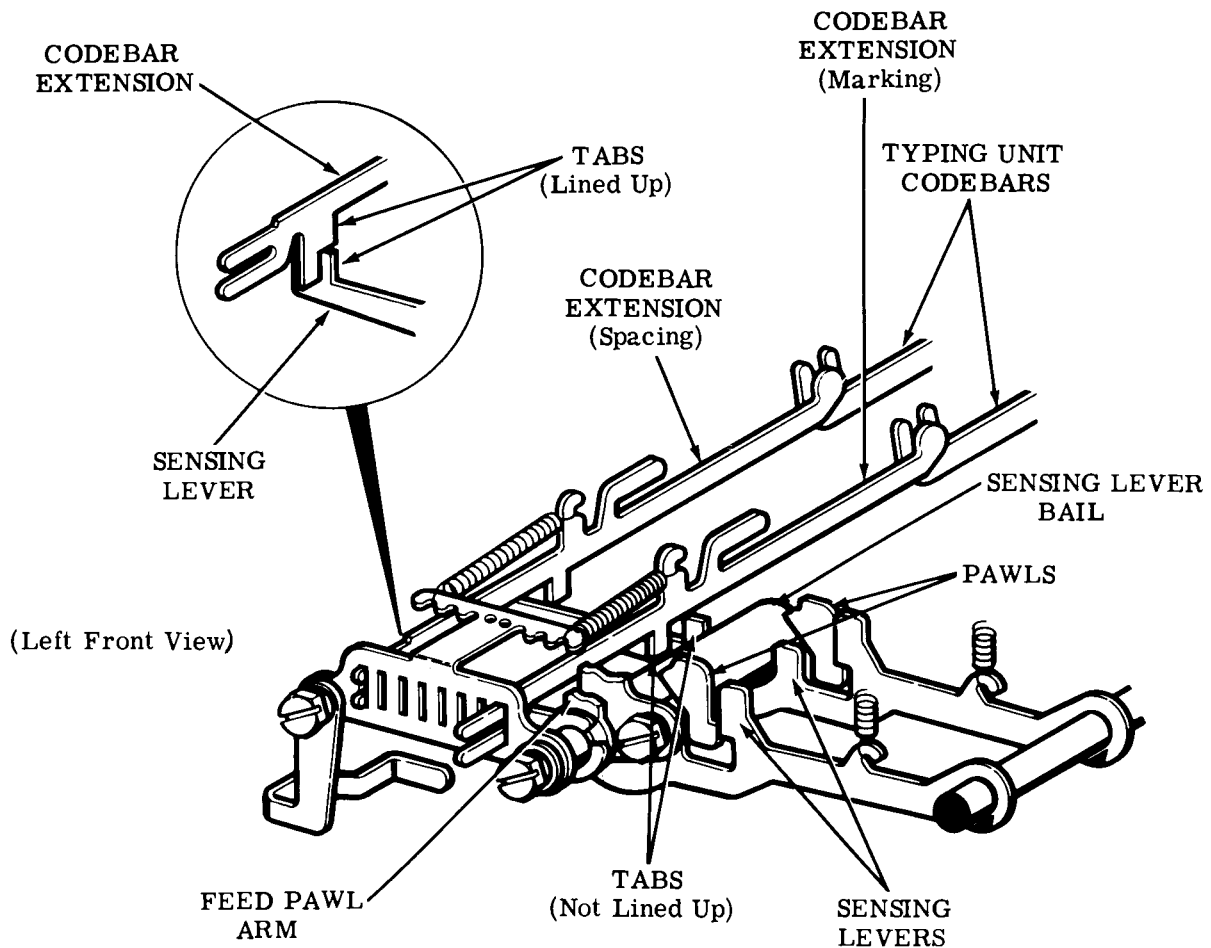

Figure 5 - Intelligence Transfer Mechanism

3.06 When a codebar extension is spacing, the tab, located on its underside, lines up with the tab on the sensing lever. The tabs engage each other, and the sensing lever is blocked from pivoting to its most clockwise position. ←

3.07 When a codebar extension is marking, its tab is not in line with the sensing lever tab. As a result the sensing lever pivots to its most clockwise position.

3.08 The feed sensing lever always travels to its most clockwise position, since it has no tabs. This motion is presented to the pawl, lever, and feed-punch pin combination through a latching surface on the pawl.

3.09 When the tape punch is off, each pawl is in its highest vertical position, each lever in its most counterclockwise position, and ← each code-punch pin in its most downward position — below the surface of the tape.

3.10 When a sensing lever is in the spacing position, its latching surface is prevented from engaging with its associated pawl latching surface. As a result the pawl is not selected.

3.11 When a sensing lever is in the marking position, its latching surface engages the latching surface on its associated pawl. When the two latching surfaces engage, the pawl is in the selected position.

3.12 As the drive mechanism (Figure 4) rotates clockwise, the feed pawl slides along the inclined surface of the adjacent ratchet tooth, drops behind it, and is cammed away from the feed wheel ratchet. Occurring simultaneously, the sensing levers rotate counterclockwise and those which are marking transfer their ← motion to the selected pawl, lever, and code-punch pin combination (see Figure 8). At the same time, the sensing levers which are spacing are in the nonselected position, and no motion is transferred to them. This results in no per-

foration of the tape, since the code-punch pins remain in their most downward position below the tape's surface. As the drive mechanism continues and reaches its most clockwise position, the code-punch pin of a selected pawl, lever, and code-punch pin combination travels upwards, perforates a hole in the tape, and continues to its most vertical position. The feed hole is always perforated in the tape since its pawl and lever are always selected.

3.13 Just prior to the end of the drive mechanism's most clockwise travel, the stripper bail, through its bias spring, engages a latching surface located under the spring hook(s) of the selected pawl(s). As the drive mechanism rotates counterclockwise to its stop position, the stripper bail strips the selected pawls from their sensing levers. The selected pawl, lever, and code-punch pin combinations return to their stop positions through their bias springs and the retractor mechanism. The lever bail of the drive mechanism also acts as a part of the retractor mechanism. As the stripper bail strips the pawls, a cam surface on the pawl, which acts as the other member of the retractor mechanism, engages the sensing

lever bail post and cams the pawl upwards to the stop position. During this portion of the drive mechanism's travel, the codebar extensions are reset by the codebar reset bail.

3.14 During the drive mechanism's clockwise motion, the nudger (Figure 4) performs its function. Motion is transferred from a cam profile, located on the nudger arm, through a post molded as an integral part of the nudger. The nudger rotates counterclockwise, engages, and nudges the tape gently when the selected code-punch pins are engaged with the tape. This enables the tape to be advanced a small amount without affecting tape feed spacing, since only the weight of the paper between the tape roll is reflected to the feed wheel when the tape is being advanced.

TAPE FEED MECHANISM

3.15 As the stripper bail moves to the rear, the feed pawl engages a tooth on the feed wheel ratchet (Figure 6). When the stripper bail completes its travel to the rear, the feed wheel ratchet has indexed one full tooth and the tape is advanced 0.100 inch by the feed wheel.

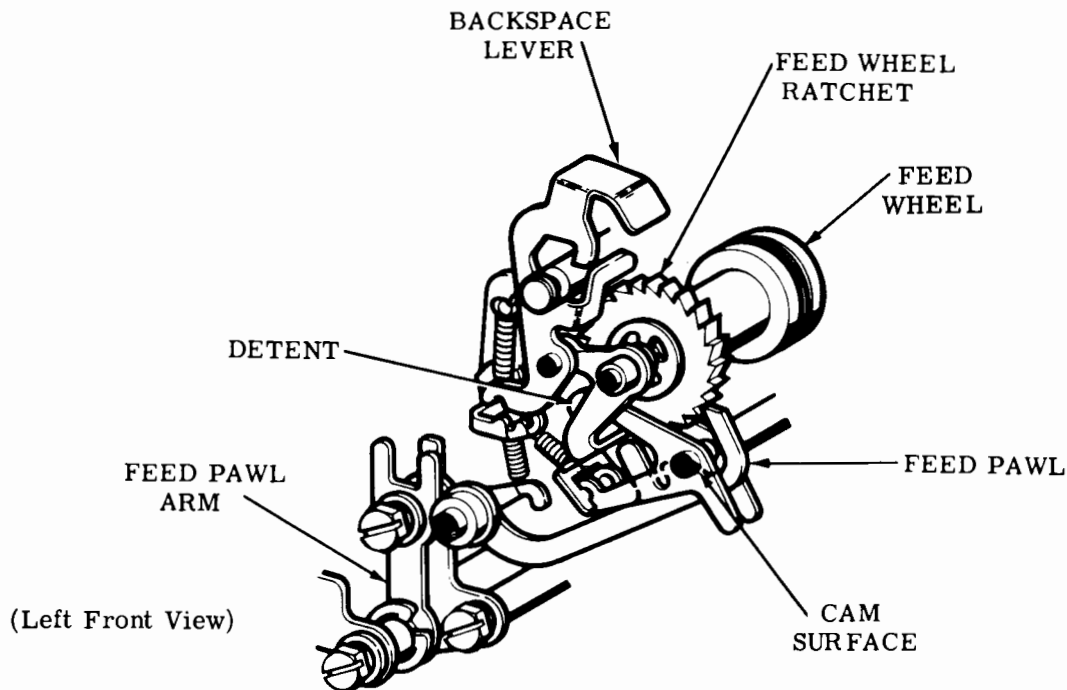

Figure 6 - Feed Wheel Mechanism (Tape Feed Mechanism)

TAPE GUIDE MECHANISM

3.16 The tape guide mechanism (Figure 7), consists of a bracket, two rollers, three posts, a sleeve, and a compression spring held together by retainers. A tension spring biases the tape guide mechanism in a clockwise direction. The knurled roller settles against the knurled feed wheel with a predetermined force. It is the combination of force and the knurled wheels that provides adequate tape spacing. The tape guide assembly is shaped in the form of a funnel to provide easy tape threading. A push-button (Figure 9), located in the cover lid, when manually pushed down against a tab located on

the REL. bracket, disengages the tape guide assembly from the feed wheel, thereby providing easy tape removal from the tape punch.

PUNCH BLOCK MECHANISM

3.17 The punch block mechanism consists of code-punch pins, a feed-punch pin, holder, die plate, and a tape bias spring (Figure 8). The code-punch pin and feed-punch pin are oriented to the die plate through slots which engage levers for their respective code level. The tape bias spring always biases the tape against one edge of the holder. This results in the code hole and feed hole relation to the tape edge to be held constant.

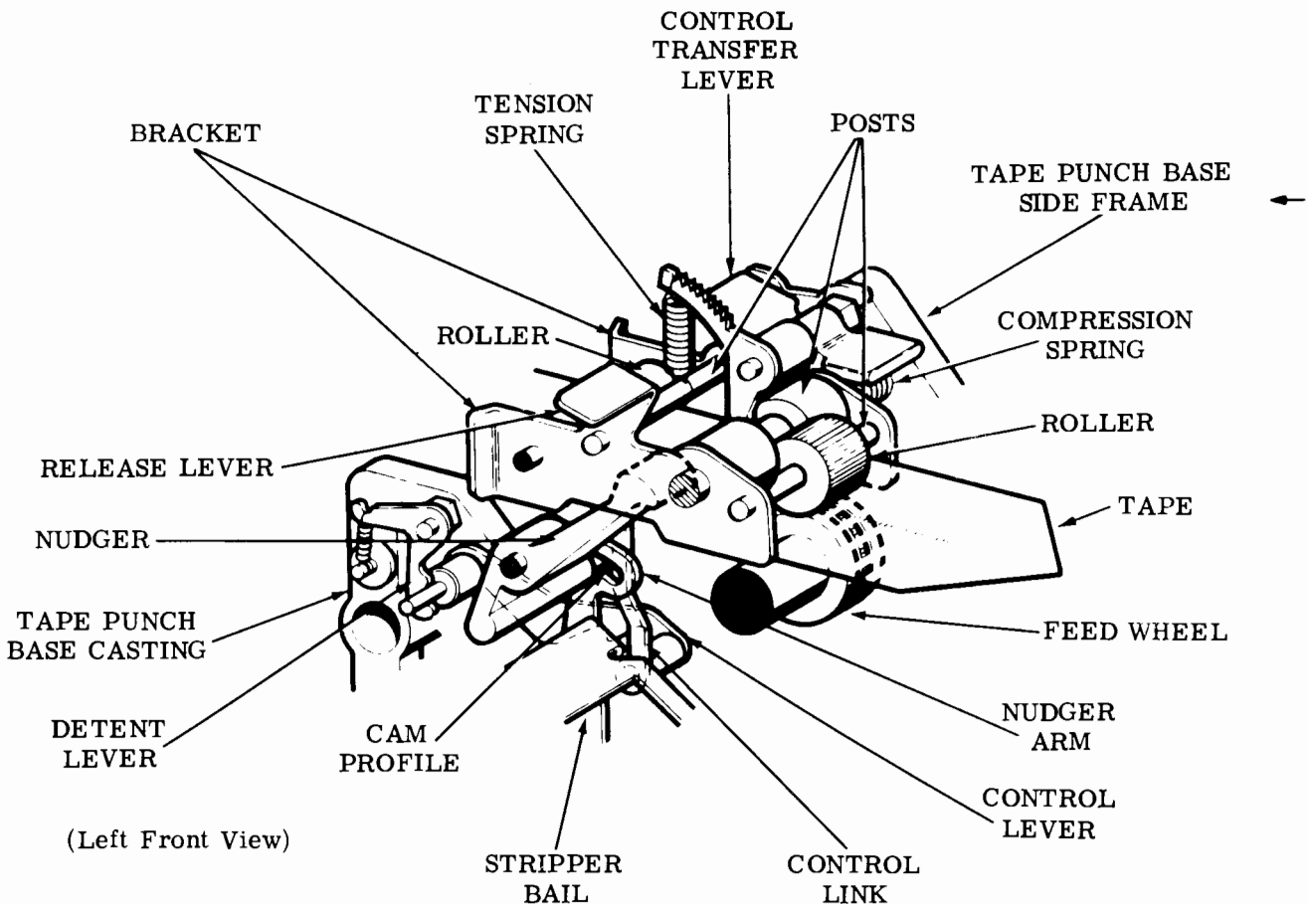

Figure 7 - Tape Guide Assembly (Tape Feed Mechanism)

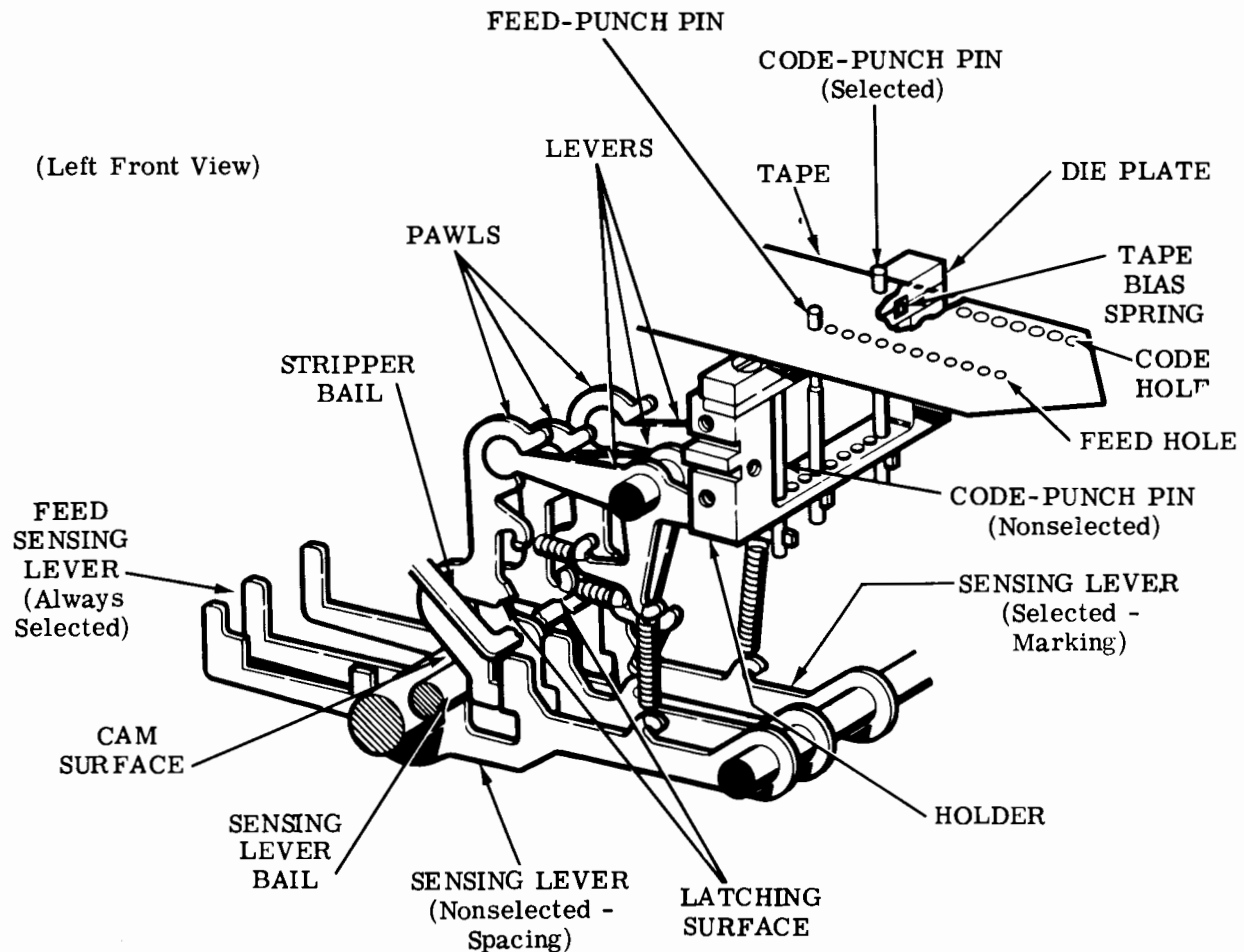

Figure 8 - Tape Punch Mechanism

BACKSPACE MECHANISM

3.18 The backspace lever (Figure 6), when depressed manually to its most downward position, backspaces the feed wheel ratchet one tooth space. This results in the tape being backspaced one full character. The backspace lever, through another lever, cams out the feed pawl during the backspace operation. This is a safety feature to prevent a jam if the operator accidentally operates the backspace mechanism while the tape punch is running.

4. CONTROL FEATURES

MANUAL PUNCH

4.01 The manual punch has four pushbuttons: ON, OFF, B.SP., and REL. (Figure 9), whose functions are:

ON — When the ON pushbutton on the cover is depressed, (Figure 10) the control transfer lever operates a

control link which, in turn, rotates the control lever. The control lever has a roller on one end and a detent on the other. The detent engages a drive post while the roller guides the drive link. When the control lever is rotated in the ON mode, the detent disengages from the drive post while the roller pivots downward. The drive link, under spring tension, is pulled downward to engage the drive post.

OFF — When the OFF pushbutton on the cover is depressed, the control transfer lever operates the control link and then the control lever is operated. The detent on the control lever travels downward to engage the drive post while the roller pivots upward, disengaging the drive link from the drive post.

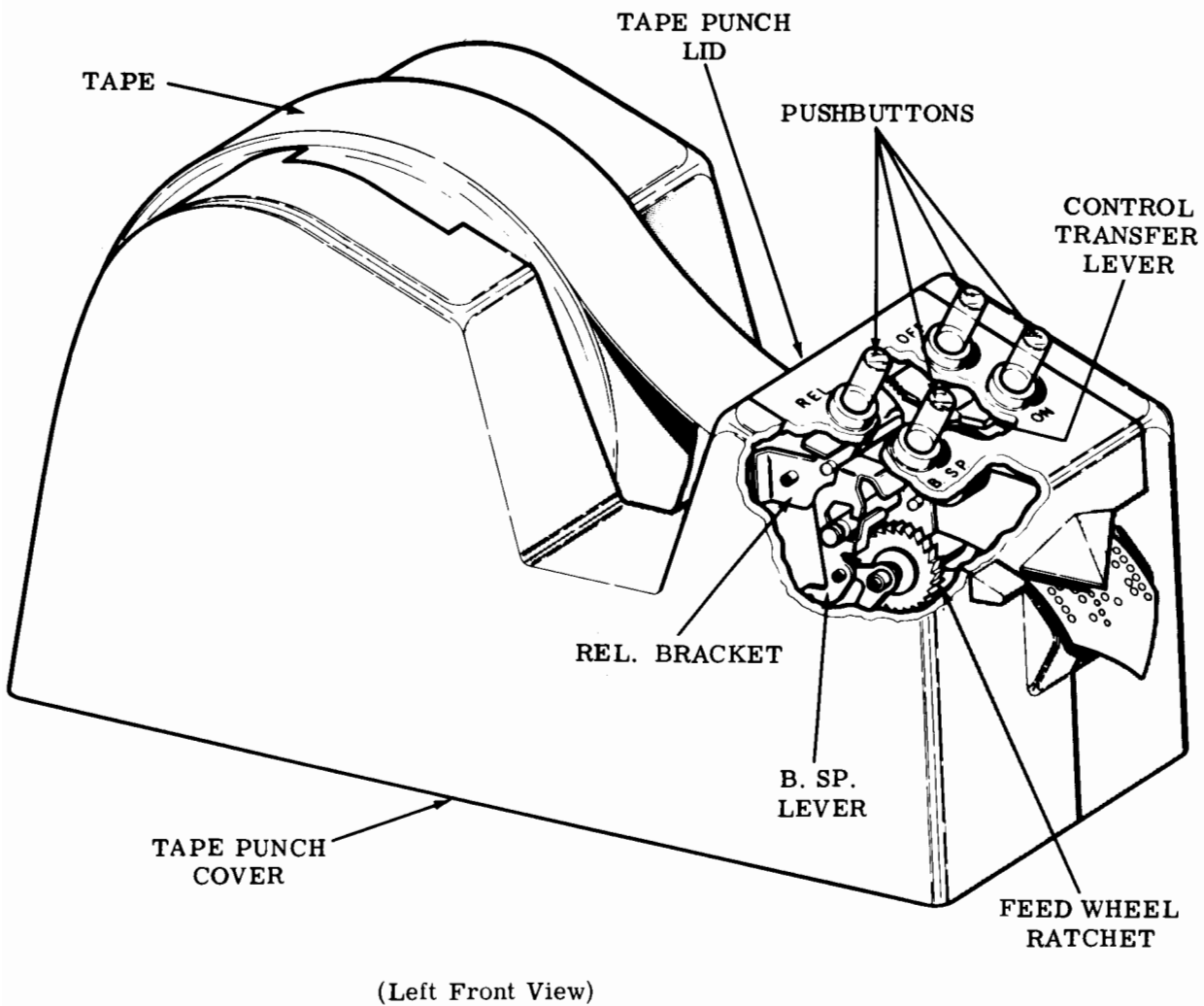

Figure 9 - Control Mechanism

B.SP. — When the B.SP. pushbutton on the cover is depressed, the backspace mechanism, described in 3.18, is operated. The backspace lever, when depressed, moves down to engage a tooth on the back side of the feed wheel ratchet (Figure 11). Simultaneously, a lever pivots the feed pawl away from the feed wheel ratchet which then turns counterclockwise, backspacing one tooth. The feed wheel is mounted on the same shaft as the ratchet. When the ratchet backspaces, the feed wheel also backspaces.

REL. — When the REL. pushbutton on the cover is depressed, the entire backspace mechanism (Figure 7) pivots counterclockwise raising the roller away from the feed wheel. The tape can thus be pulled out freely.

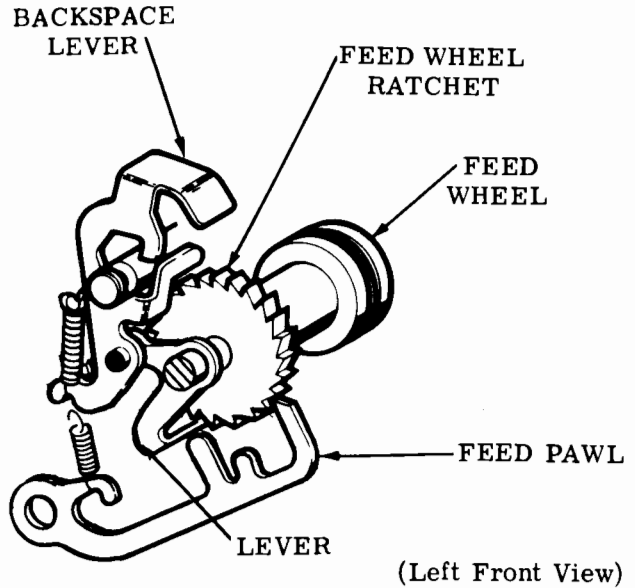

Figure 11 - Feed Wheel Mechanism (Tape Feed Mechanism)

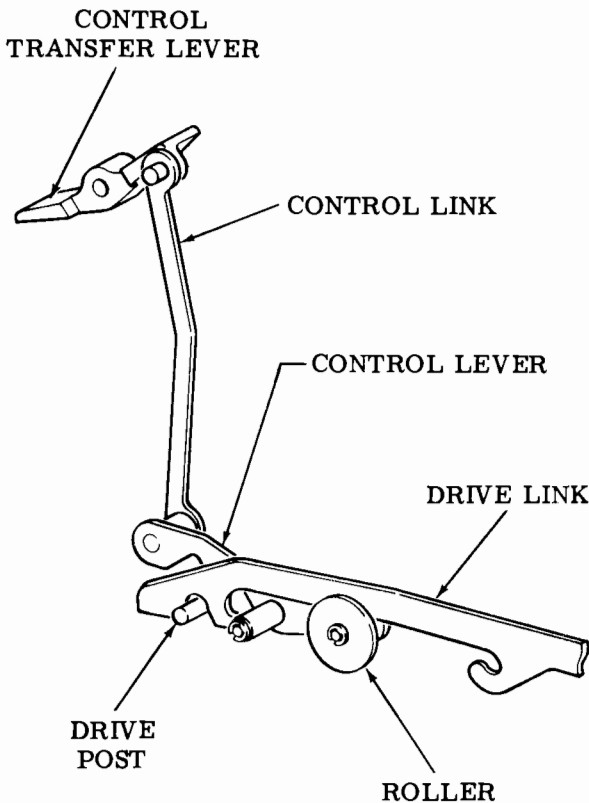

Figure 10 - Manual ON and OFF Mechanism

AUTOMATIC PUNCH

4.02 The automatic punch has four pushbuttons, similar to the manual punch. The pushbuttons are: ON, OFF, B.SP., and REL.

ON — Depressing the ON pushbutton (Figure 12) on the cover lid causes a lever, link, the lever assembly, and the link with stud to pivot. In its pivoting motion, the stud causes the latch bail to pivot counterclockwise disengaging the ON-OFF bail lever, allowing it to move towards the rear. In this rearward travel the stud, which in the OFF condition holds the feed pawl down away from the feed wheel ratchet, also moves towards the rear allowing the feed pawl to reach up and engage a tooth on the feed wheel ratchet.

OFF — When the OFF pushbutton (Figure 12) is depressed, its lever is pivoted away from the engaging surface of the ON lever allowing the spring-biased levers to return to their OFF position. The latch bail pivots upward to engage the ON-OFF bail lever and the stud moves the feed pawl downward away from the feed wheel ratchet teeth.

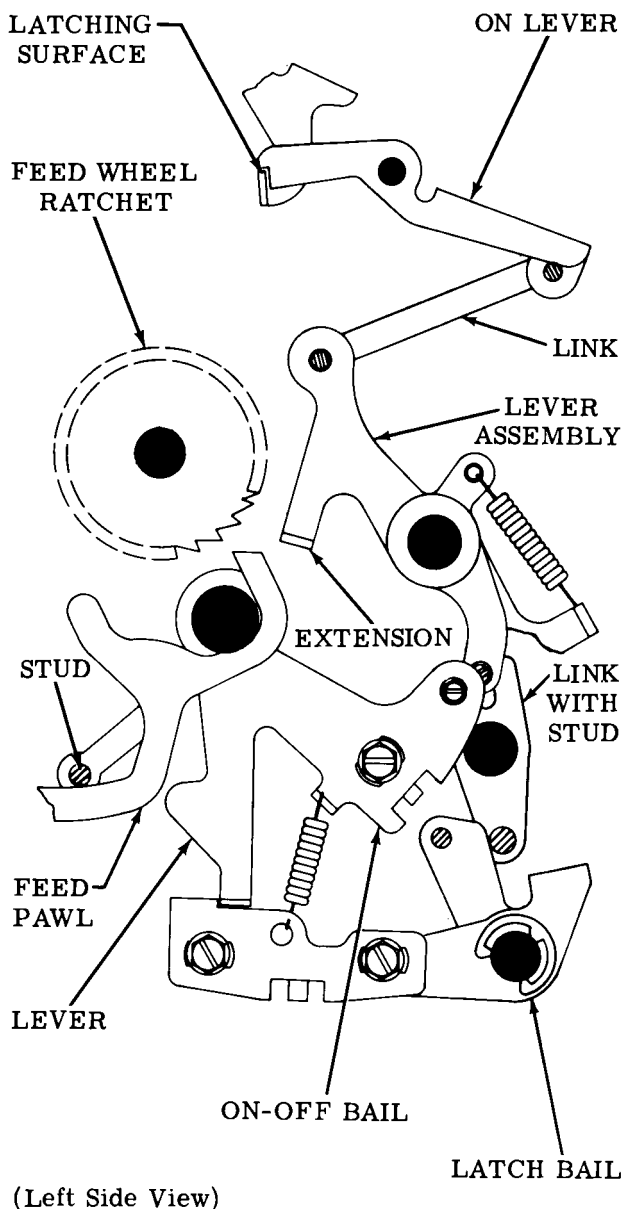

(Left Side View)

Figure 12 - Automatic ON and OFF Mechanism

B.SP. — Same as the manual punch back-space operation described in 4.01

REL. — Same as the manual punch release operation described in 4.01

4.03 Automatic ON (Figure 13) — For turning the tape punch ON automatically the same mechanism that turns it ON manually is used. When the "R" and "Control" keytops of the local

set or the distant set are depressed, a code combination is set up in the typing unit codebars and codebar extensions. The A-8 sensing lever senses the codebar extensions and travels upwards, positioning a pawl and lever. In its pivoting motion the lever engages an extension of the lever assembly causing it to pivot as described in 4.02. The pivoting action of the lever assembly causes the link with stud to pivot. Subsequently, the latch bail moves downward disengaging the ON-OFF bail whose stud moves away from the feed pawl. The feed pawl then reaches up to engage a tooth on the feed wheel ratchet.

4.04 Automatic OFF (Figure 14) — When the "T" and the "Control" keytops are depressed on the keyboard, the tape punch OFF code combination is set up in the typing unit codebars and codebar extensions. The A-0 sensing lever senses the codebar extensions and positions a pawl and lever. The lever has an extension which causes the post of the ON-OFF bail to move upward. Simultaneously, the stud engages the feed pawl and pulls it down disengaging it

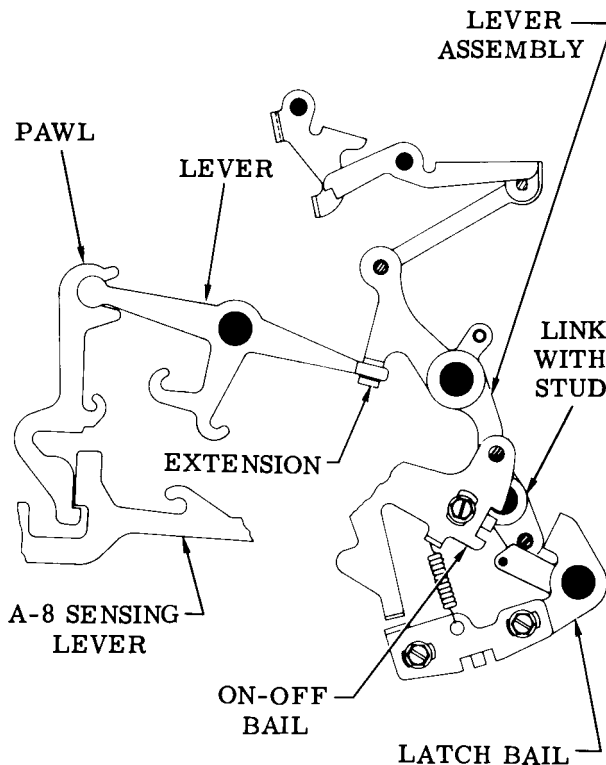

(Left Side View)

Figure 13 - Automatic ON Mechanism

from the feed wheel ratchet. The ON-OFF bail lever drops in the engaging surface of the spring biased latch bail. During subsequent cycles, the sensing levers will sense incoming code

combinations but the selected pawls will be stripped each time. Likewise, there will be no action of the feed pawl and the tape will not be advanced.

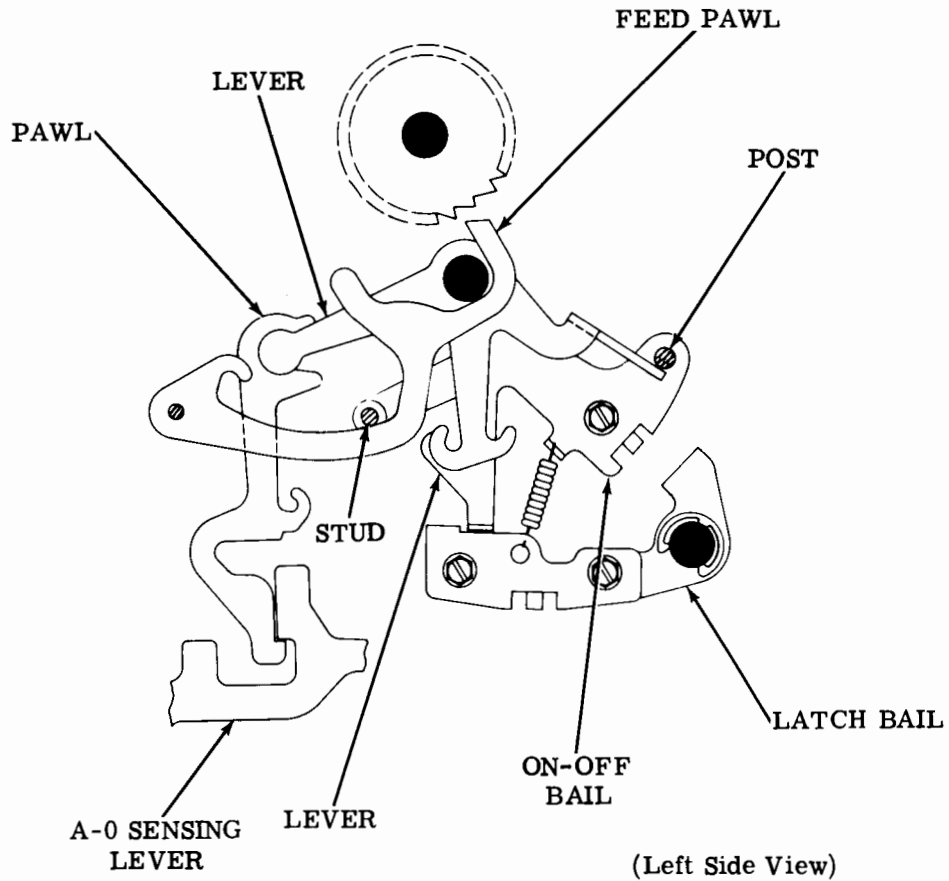

Figure 14 - Automatic OFF Mechanism

33 TAPE PUNCH
 LUBRICATION

CONTENTS	PAGE
1. GENERAL	1
2. BASIC UNIT	2
Backspace lever	8
Codebar levers	5
Control mechanism	5
Detent lever	8
Drive link mechanism area	2
Drive link mechanism (early design)	3
Drive link mechanism (late design)	3
Feed mechanism	7
Feed pawl	7
Pawls and levers	6
Punch block assembly	9
Sensing levers	6
Stripper bail	6
Support link (late design)	3
Tape guide assembly	8
Tape guide roller	9
Tape punch	4
3. VARIATIONS TO THE BASIC UNIT	10
Automatic on-off bail drive lever	11
Automatic on-off control bail	11
Automatic on-off control levers	12
Automatic on-off control mechanisms	13
Automatic tape punch	10
Lock "ON" mechanism	14
Punch interlock mechanism	14
Sense suppression mechanism	15
4. VARIABLE FEATURE	16
Tape guide for folded tape	16

ments for the tape punch. Marginal arrows indicate changes and additions.

1.02 The general lubrication areas are illustrated by photographs. The specific points to receive lubricant are indicated on line drawings with appropriate textual instructions. Line drawings and textual instructions follow each photograph and are keyed to the photograph by paragraph numbers.

1.03 Thoroughly lubricate the tape punch, but avoid overlubrication that might permit the lubricant to drip or be thrown onto adjacent parts. Saturate all felt washers and oilers with oil.

1.04 Initial lubrication of the tape punch should be completed just prior to placing it into service. The lubrication intervals for the tape punch are similar to the lubrication intervals of the set. The lubrication intervals are dictated by the hours of use (including idle time) on a daily basis. The following charts and notes list the appropriate lubrication intervals.

LUBRICATION INTERVALS IN WEEKS
 BASED ON 5-DAY WEEK (Note 1)

NEWLY INSTALLED EQUIPMENT			
DAILY USE			
SPEED	0 TO 8 HOURS	8 TO 16 HOURS	16 TO 24 HOURS
All Speeds	3 Weeks	2 Weeks	1 Week

REGULAR LUBRICATION			
DAILY USE			
SPEED	0 TO 8 HOURS	8 TO 16 HOURS	16 TO 24 HOURS
60 WPM	39 Weeks	26 Weeks	13 Weeks
100 WPM	26 Weeks	13 Weeks	6 Weeks

1. GENERAL
 1.01 This section provides lubrication requirements for the 33 tape punch. It is reissued to add new lubrication interval require-

Note 1: Reduce lubrication interval 15 percent when usage is 6 days per week, 30 percent when usage is 7 days per week.

Note 2: Sets operating at speeds between 60 and 100 wpm use lubrication requirements for the lower of the two speeds.

Note 3: The lubrication intervals are for the set as a whole — all components of the set should be lubricated.

Note 4: Just prior to storage, all equipment should be thoroughly lubricated.

1.05 The textual instructions that accompany the line drawings consist of abbreviated directions, specific lubrication points, and parts affected. The meanings of the abbreviated directions (symbols) are given below.

Symbol	Meaning
D	Keep dry — no lubricant permitted
O	Oil (TKS7470)

1.06 References to left, right, front, or rear, etc, consider the tape punch to be viewed from a position where the tape guide

2. BASIC UNIT

2.01 Drive Link Mechanism Area

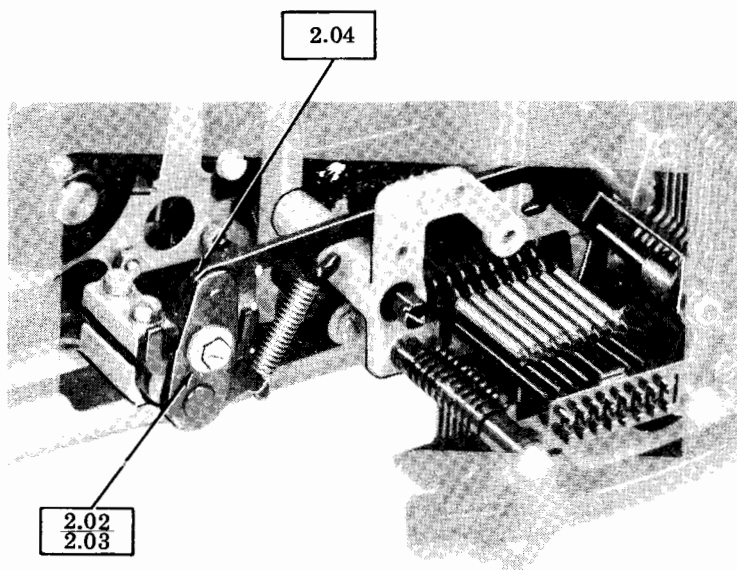

(Left Side View)

assembly faces up and the backspace lever is to the viewers's left. Orientation references in the drive link mechanism area consider the drive link to be up and located to the viewer's left.

CAUTION: DO NOT USE ALCOHOL, MINERAL SPIRITS, OR OTHER SOLVENTS TO CLEAN PLASTIC PARTS OR PARTS WITH PROTECTIVE-DECORATIVE FINISHES. NORMALLY, A SOFT, DRY CLOTH SHOULD BE USED TO REMOVE DUST, OIL, GREASE, OR OTHERWISE CLEAN PARTS OR SUBASSEMBLIES. IF NECESSARY, A SOFT CLOTH DAMPENED WITH SOAP OR MILD DETERGENT MAY BE USED. AFTERWARDS, RINSE EACH CLEANED PART OF SUBASSEMBLY WITH A SOFT, DAMP CLOTH AND BUFF WITH A SOFT, DRY CLOTH.

1.07 Tools and materials needed for teletypewriter lubrication are listed in Section 570-005-800TC.

1.08 For disassembly and reassembly information refer to Section 574-125-702TC.

2.02 Drive Link Mechanism (Early Design)

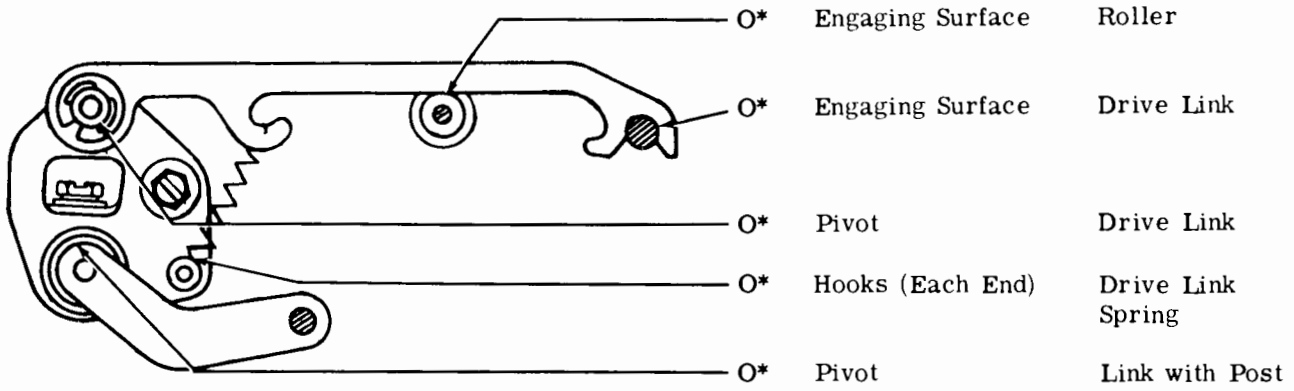

(Left Side View)

2.03 Drive Link Mechanism (Late Design)

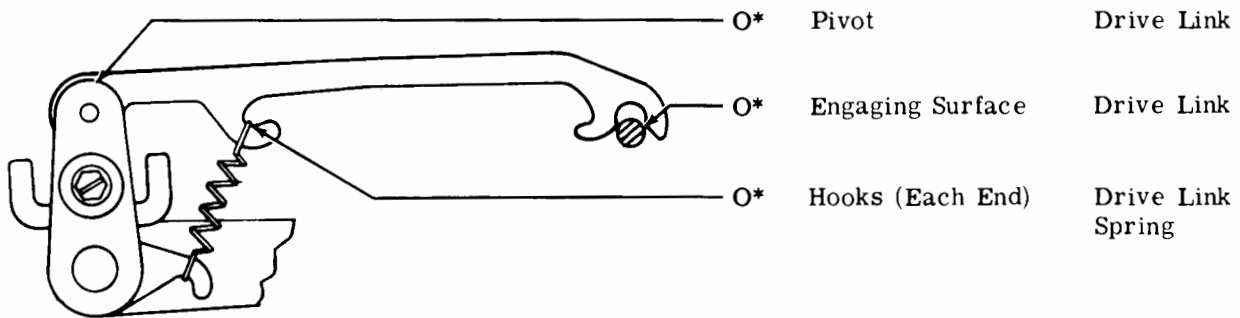

(Left Side View)

2.04 Support Link (Late Design)

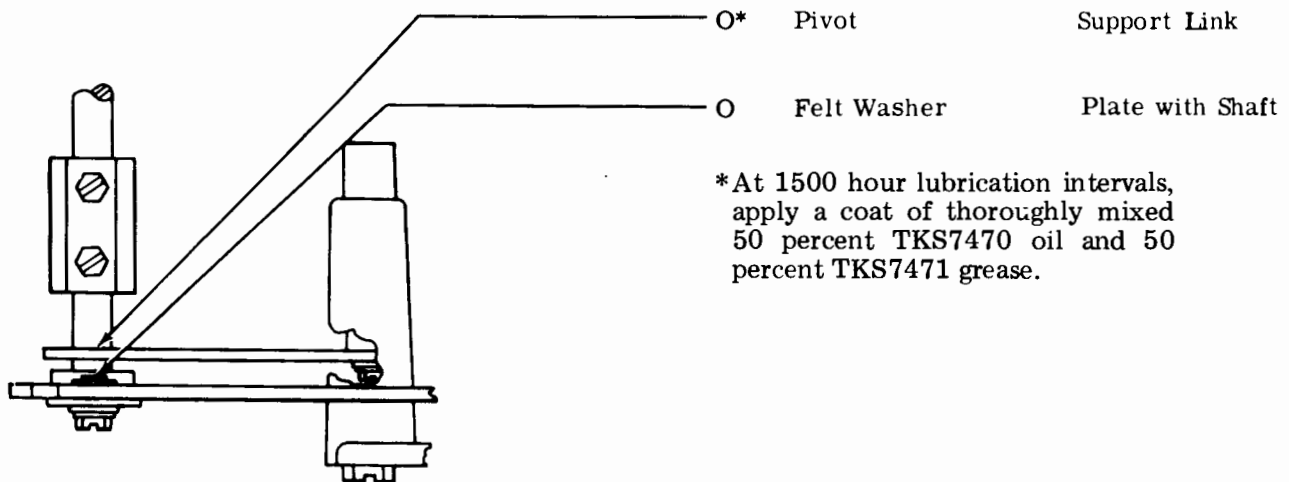

(Top View)

*At 1500 hour lubrication intervals, apply a coat of thoroughly mixed 50 percent TKS7470 oil and 50 percent TKS7471 grease.

2.05 Tape Punch

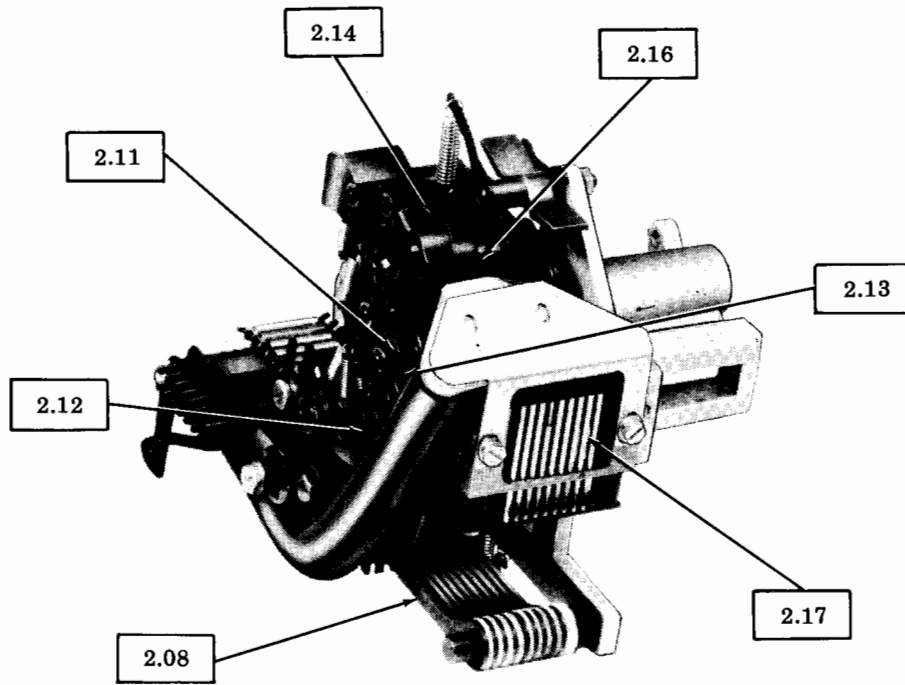

(Left Front View)

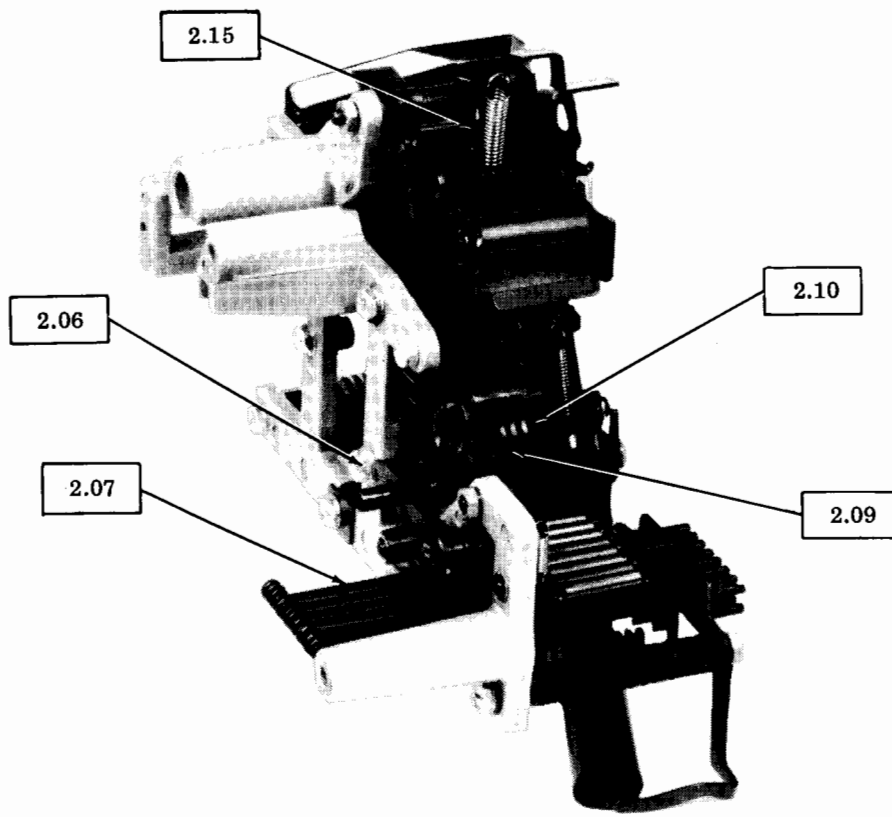

(Right Rear View)

2.06 Control Mechanism

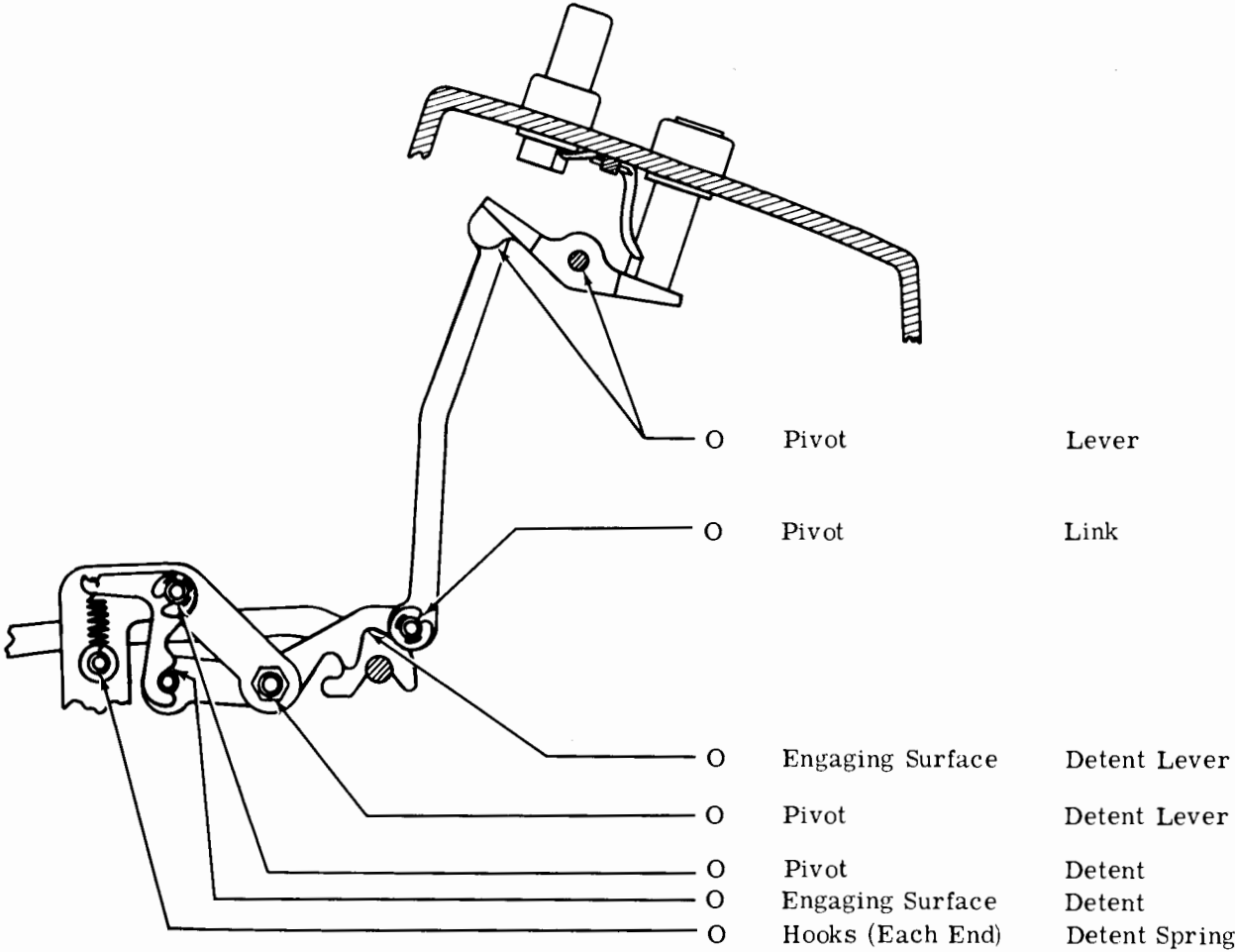

(Left Side View)

2.07 Codebar Levers

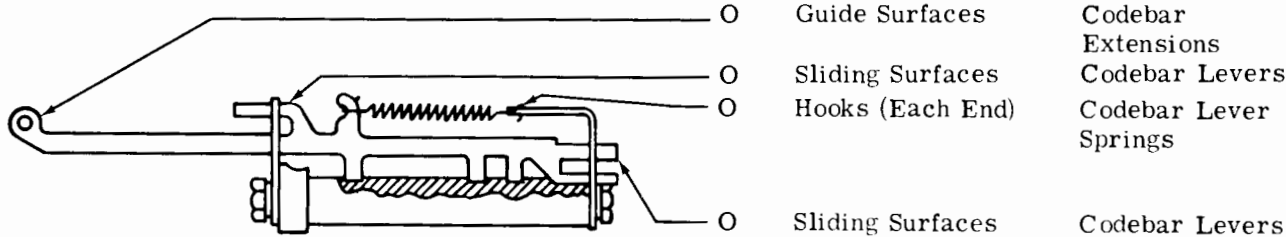

(Rear View)

SECTION 574-125-701TC

2.08 Sensing Levers

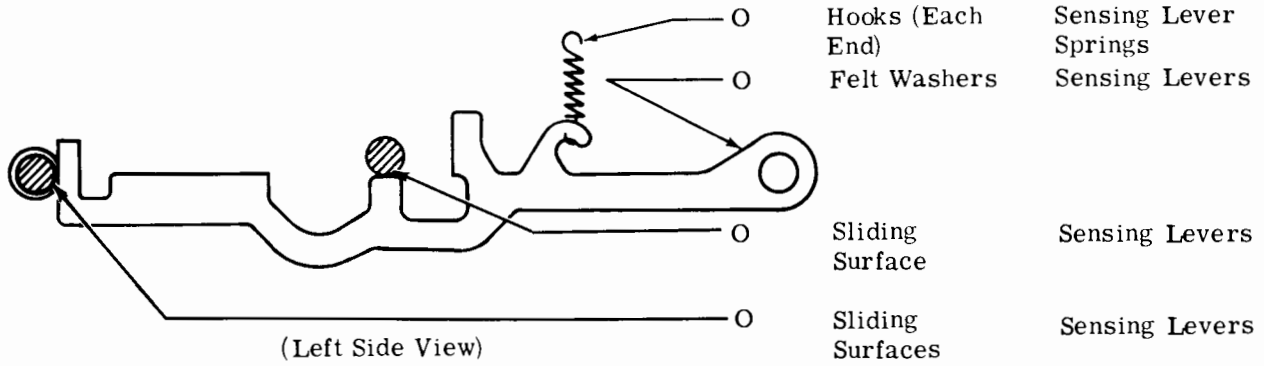

2.09 Stripper Bail

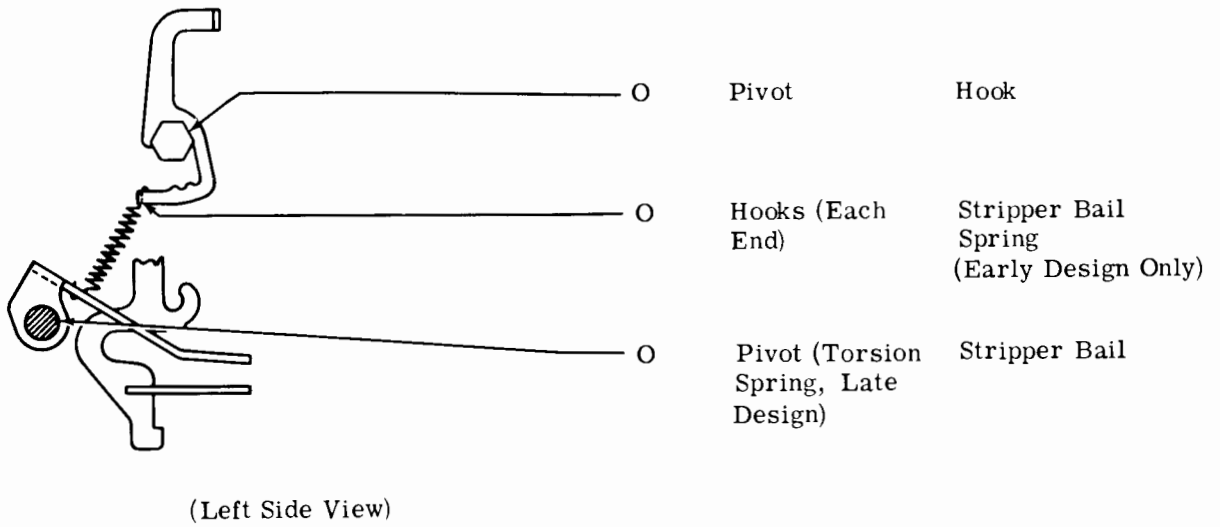

2.10 Pawls and Levers

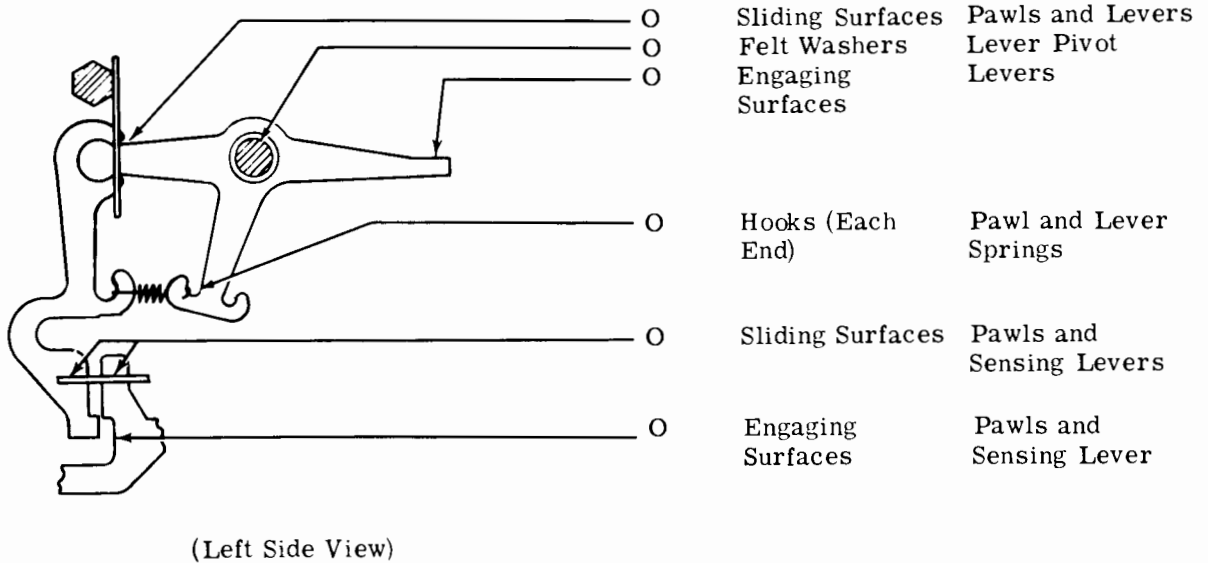

2.11 Feed Mechanism

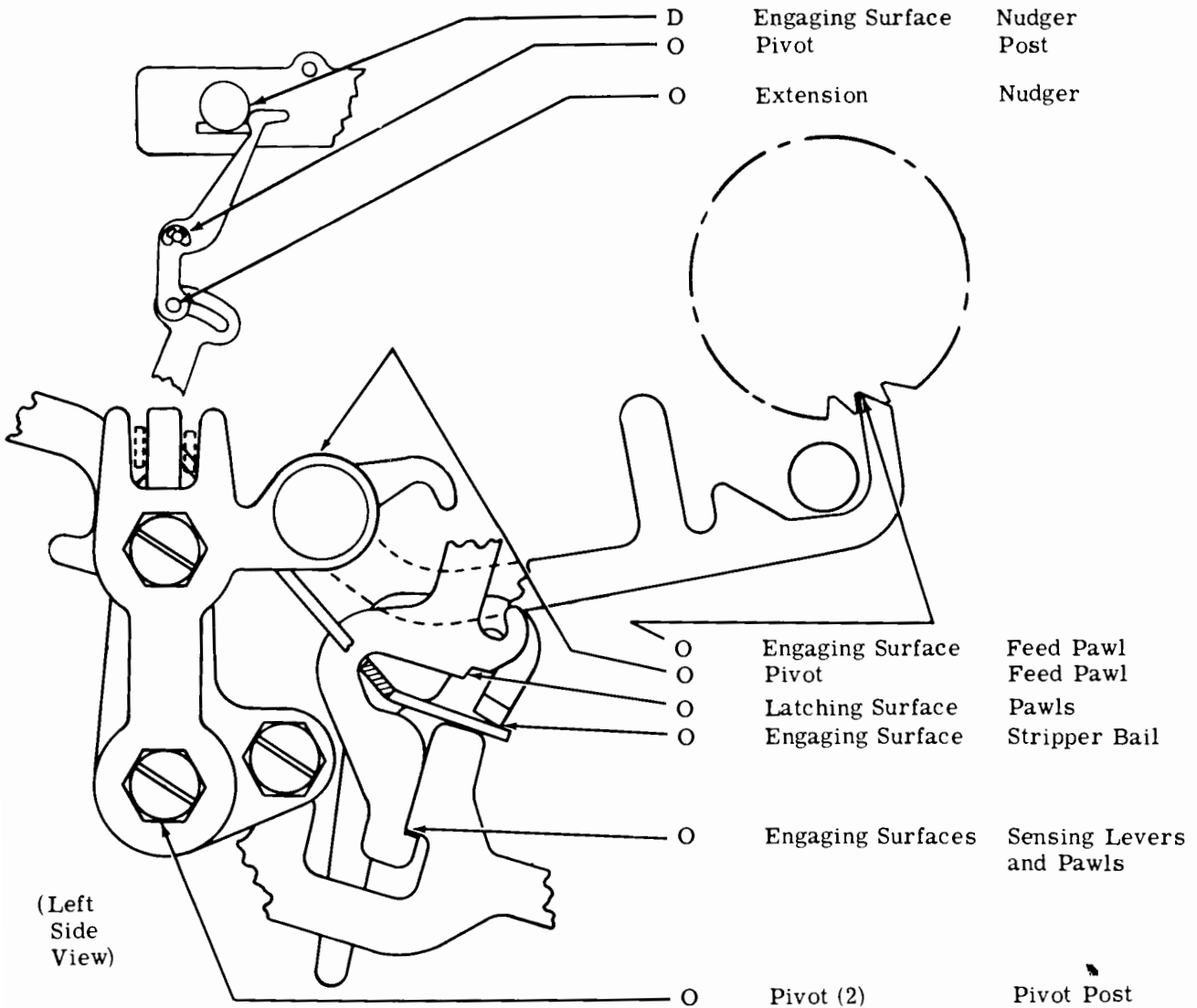

2.12 Feed Pawl

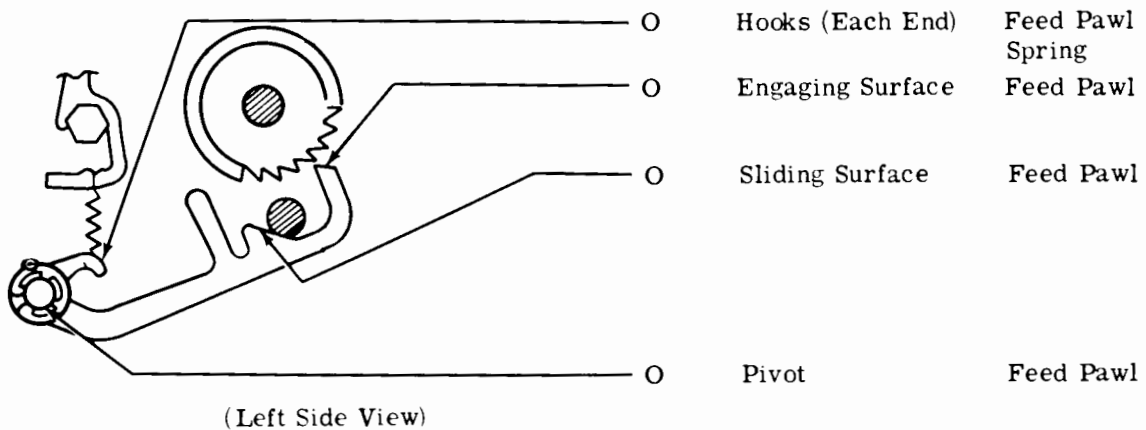

SECTION 574-125-701TC

2.13 Detent Lever

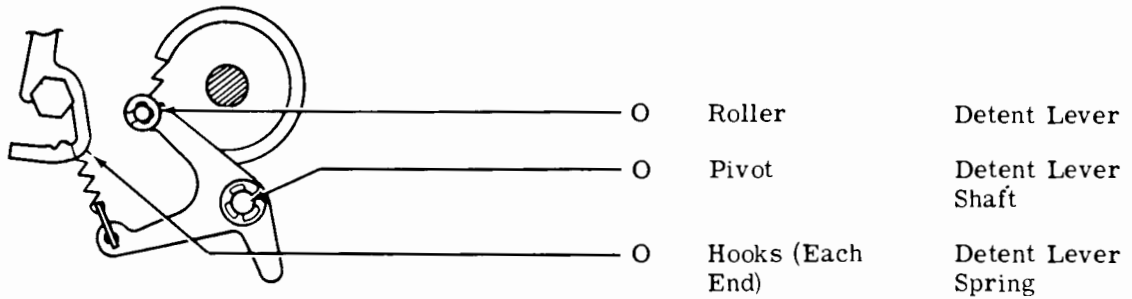

(Left Side View)

2.14 Backspace Lever

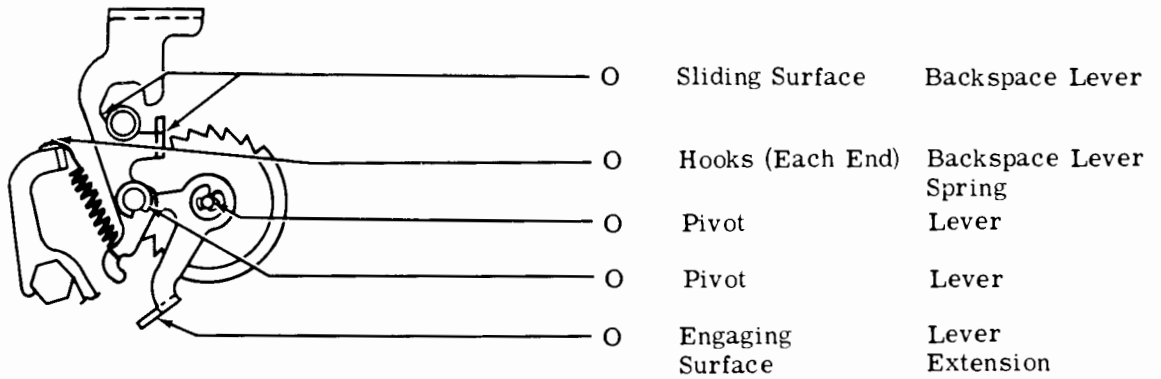

(Left Side View)

2.15 Tape Guide Assembly

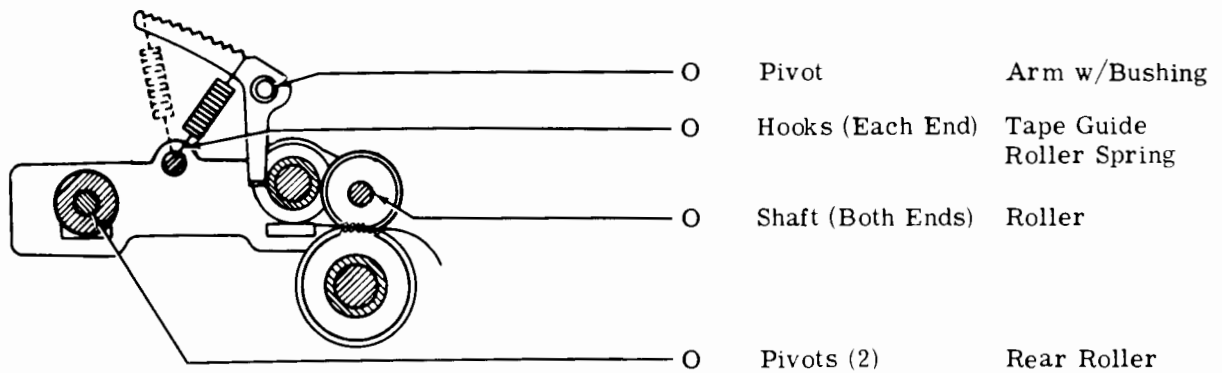

(Left Side View)

2.16 Tape Guide Roller

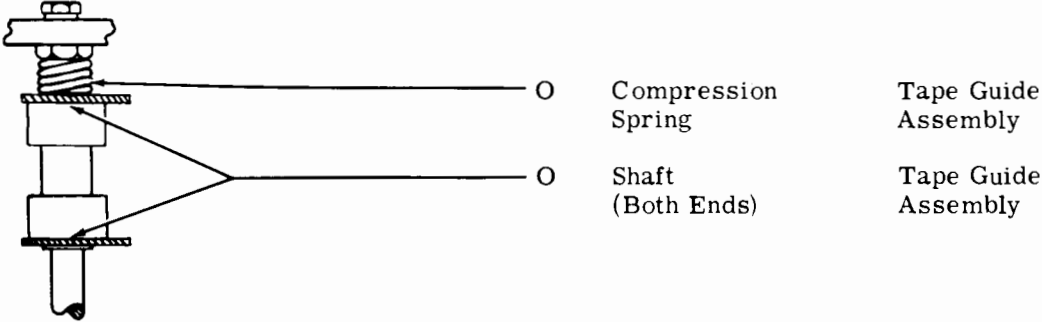

(Top View)

2.17 Punch Block Assembly

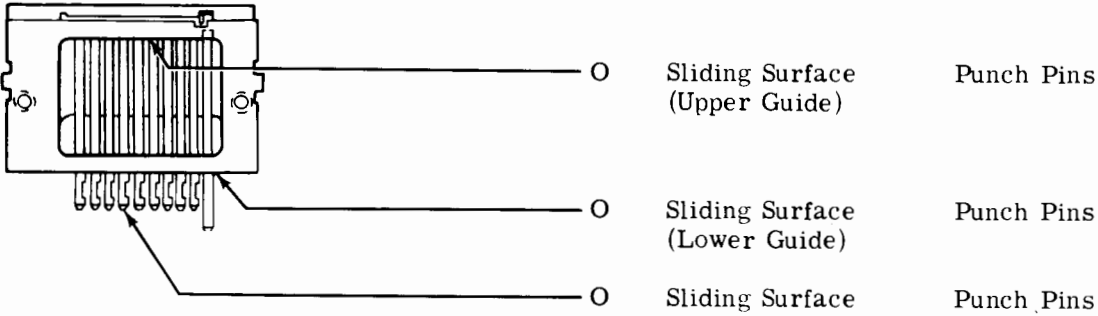

(Front View)

3. VARIATIONS TO THE BASIC UNIT

3.01 Automatic Tape Punch

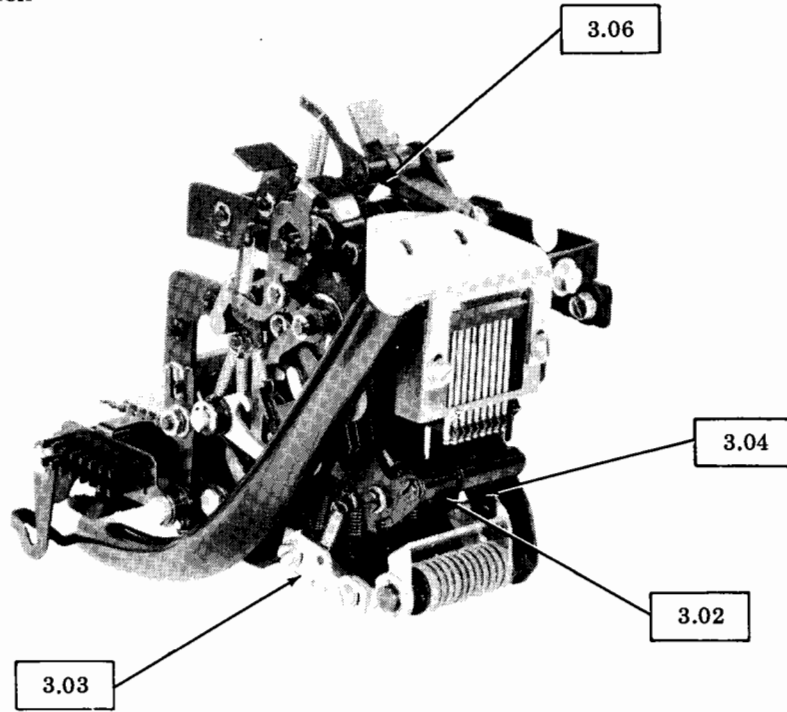

(Left Front View)

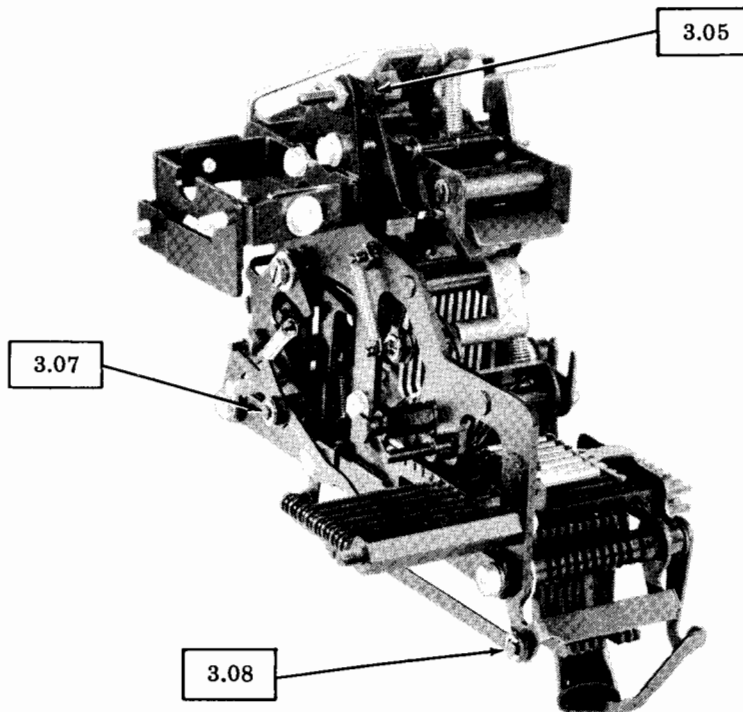

(Right Front View)

3.02 Automatic On-Off Bail Drive Lever

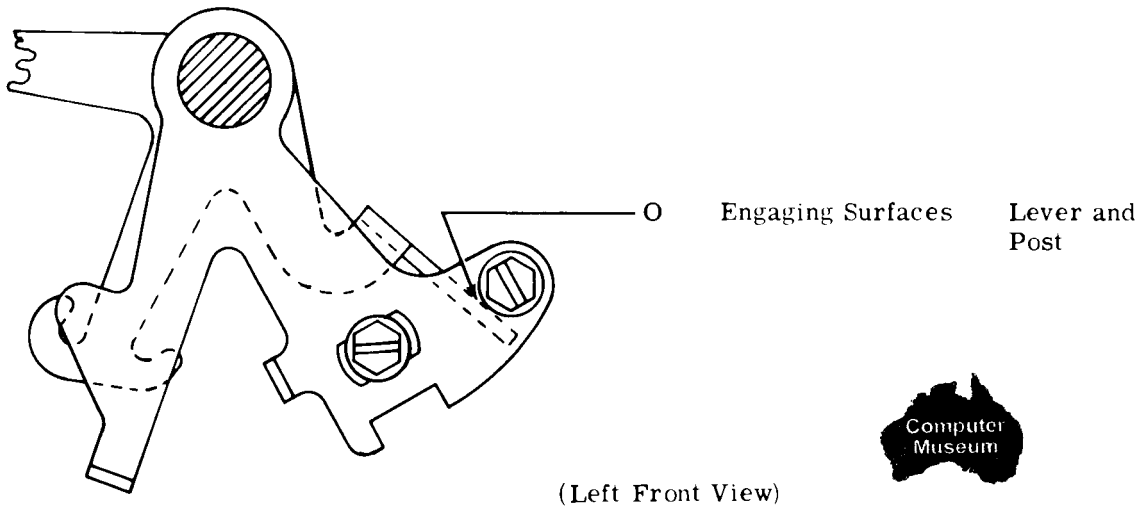

3.03 Automatic On-Off Control Bail

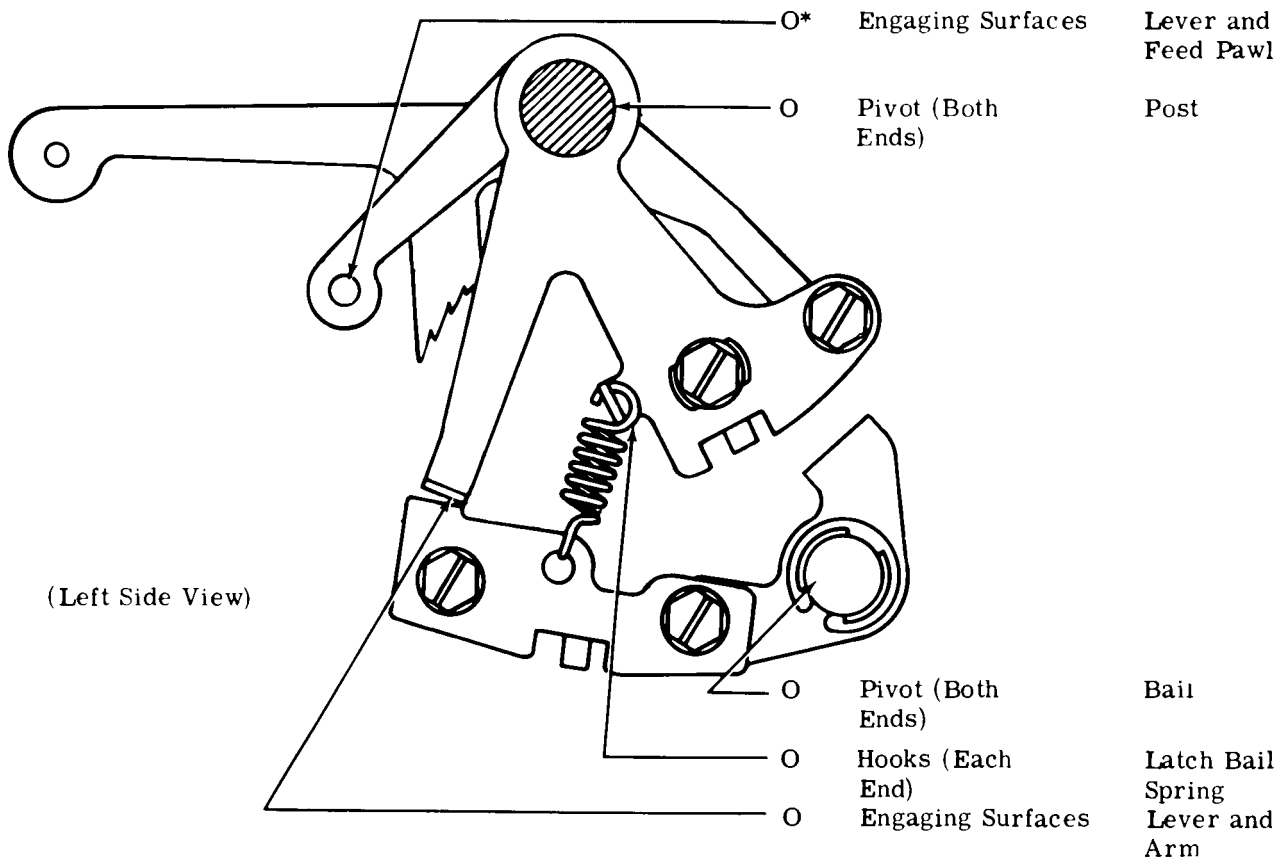

* At 1500 hour lubrication intervals, apply a coat of thoroughly mixed 50 percent TKS7470 oil and 50 percent TKS7471 grease.

3.04 Automatic On-Off Control Levers

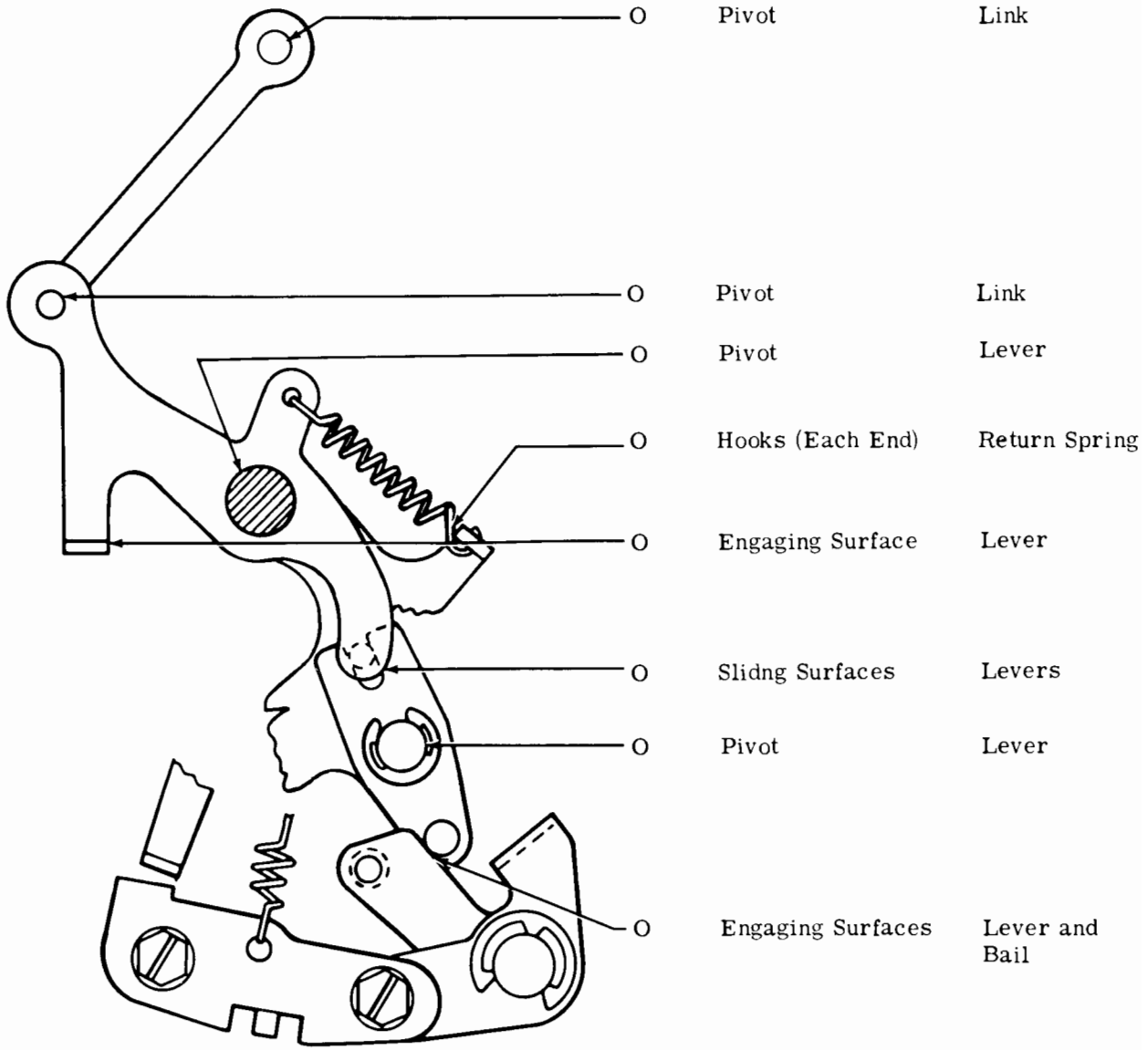

(Left Side View)

3.05 Automatic On-Off Control Mechanisms

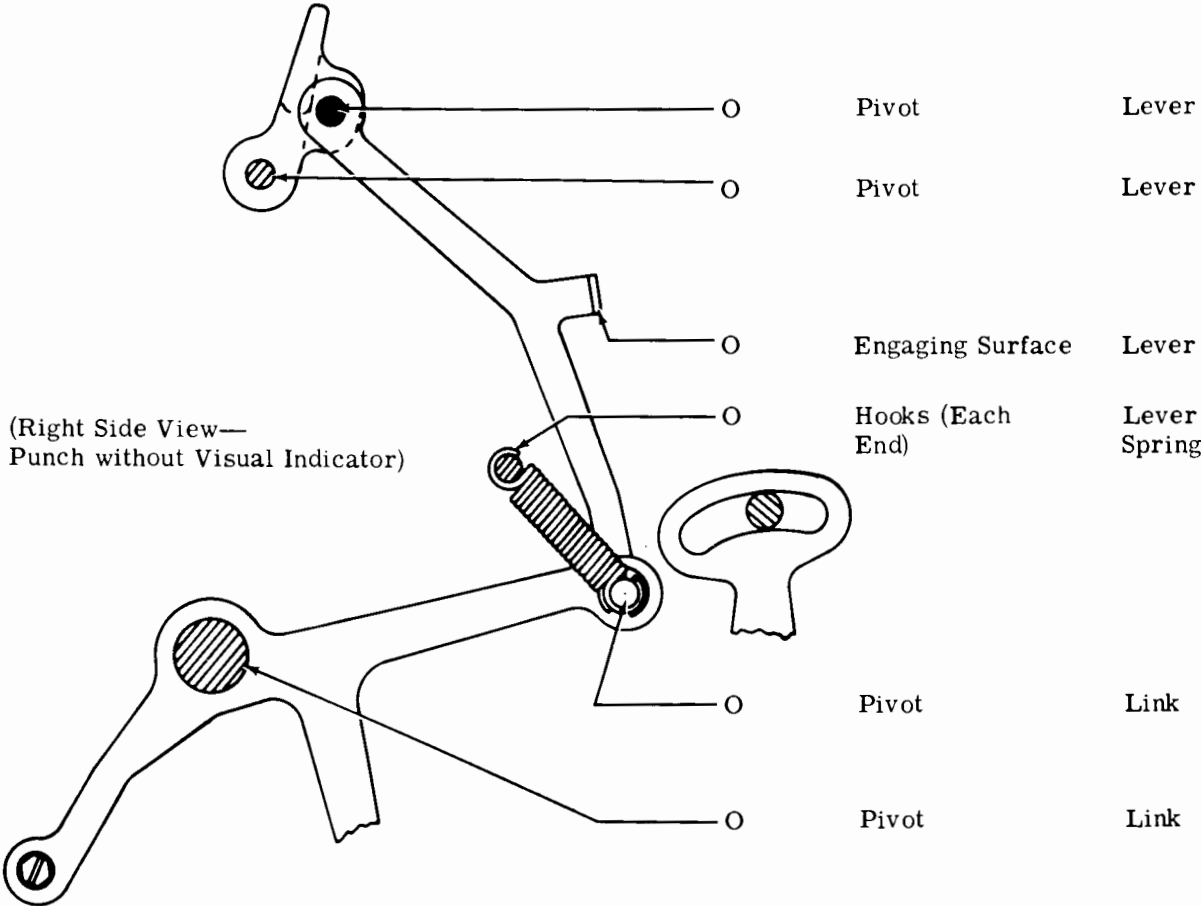

3.06 Lock "ON" Mechanism

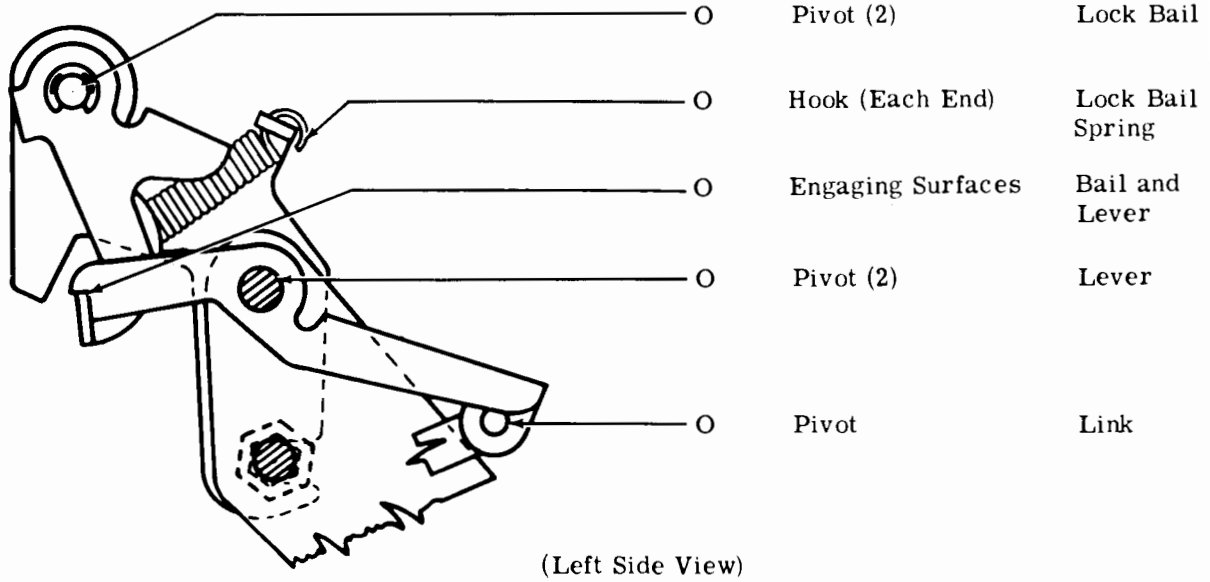

3.07 Punch Interlock Mechanism

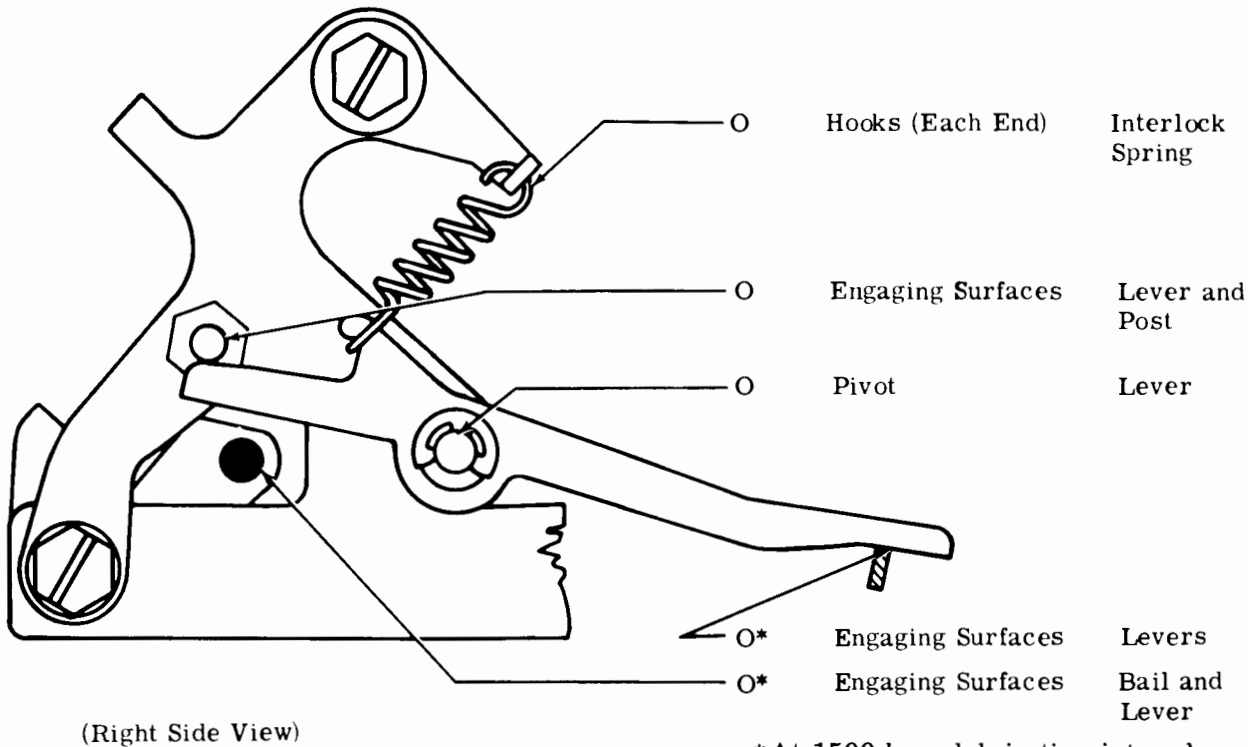

*At 1500 hour lubrication intervals, apply a coat of thoroughly mixed 50 percent TKS7470 oil and 50 percent TKS7471 grease.

3.08 Sense Suppression Mechanism

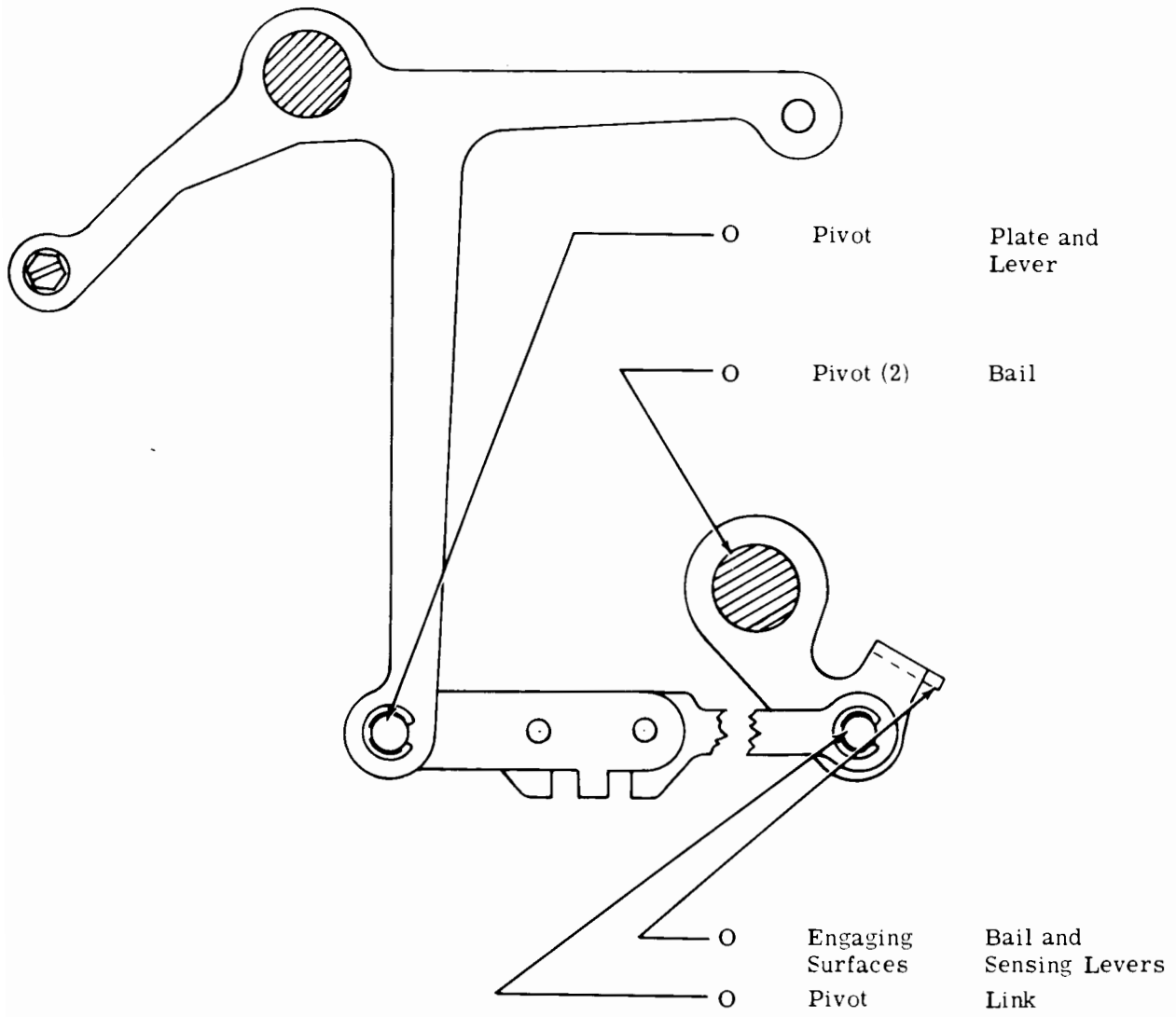

(Right Side View)

4. VARIABLE FEATURE

4.01 Tape Guide for Folded Tape

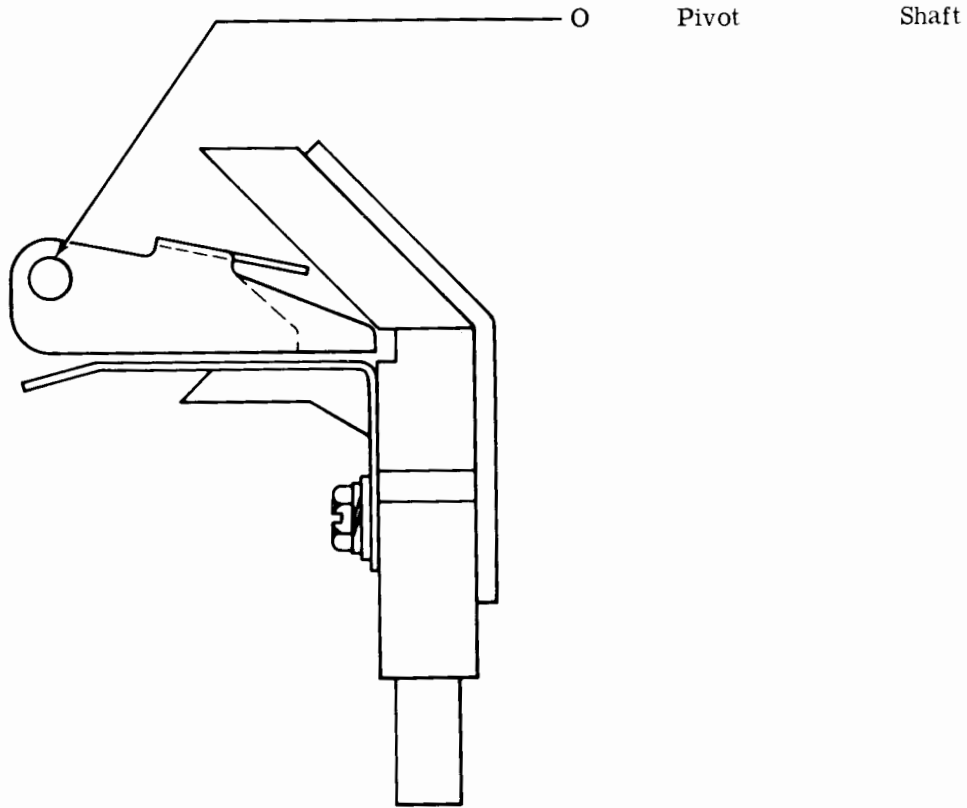

(Left Side View)

33 TAPE PUNCH

DISASSEMBLY AND REASSEMBLY

CONTENTS	PAGE
1. GENERAL	1
2. DISASSEMBLY AND REASSEMBLY	1
CHAD CHUTE ASSEMBLY	1
PUNCH BLOCK ASSEMBLY	2
A. Early Design	2
B. Late Design	2
TAPE GUIDE ASSEMBLY	3
PAWL UPSTOP ASSEMBLY	3
SENSING LEVERS AND GUIDEPLATE ASSEMBLY	4
PAWL, LEVER, AND SPRING COMBINATIONS	4

1. GENERAL

1.01 This section is reissued to incorporate all recent engineering changes and to present disassembly and reassembly information exclusively for the 33 tape punch. Since this is a general revision, marginal arrows, used to indicate changes, have been omitted.

1.02 References to left, right, front, rear, etc, consider the tape punch to be viewed from a position where tape guide assembly faces up and the backspace lever is to the viewer's left. Orientation references in the drive link mechanism area consider the drive link to be up and located to the viewer's right.

1.03 Disassembly, as outlined in this section, covers the procedure for removing the principle subassemblies which make up the unit. If further disassembly is required, refer to Section 574-125-800TC, which shows detailed arrangement of parts. Where it will help in deter-

mining their location, the numbers of the parts are given in the instructions.

1.04 When self-tapping screws are used to mount mechanisms onto castings, do not remove the self-tapping screws. Merely loosen them enough to remove the mechanisms unless specifically instructed otherwise.

1.05 Retaining rings are made of spring steel and have a tendency to release suddenly. To avoid loss of these rings when removing them, proceed as follows.

- (a) Hold retaining ring to prevent its rotating.
- (b) Place blade of screwdriver in one of ring's slots and rotate screwdriver to increase diameter.
- (c) Ring will come off easily in fingers without flying.

1.06 All tools used to remove the mechanisms referred to in this section can be found in the 570-005-800TC standard tool section. No additional special tools are required.

1.07 All damaged, worn, or distorted parts should be replaced if encountered in the disassembly and reassembly procedures.

2. DISASSEMBLY AND REASSEMBLY

Note: For information concerning the proper procedure to remove the tape punch from the set, refer to the set disassembly and reassembly section, 574-100-702TC.

CAUTION: BEFORE BEGINNING DISASSEMBLY, REMOVE CONNECTORS FROM EXTERNAL RECEPTACLES (POWER SOURCE, DATA SET, ETC).

CHAD CHUTE ASSEMBLY

2.01 To remove the chad chute assembly (Figures 1 and 3), proceed as follows.

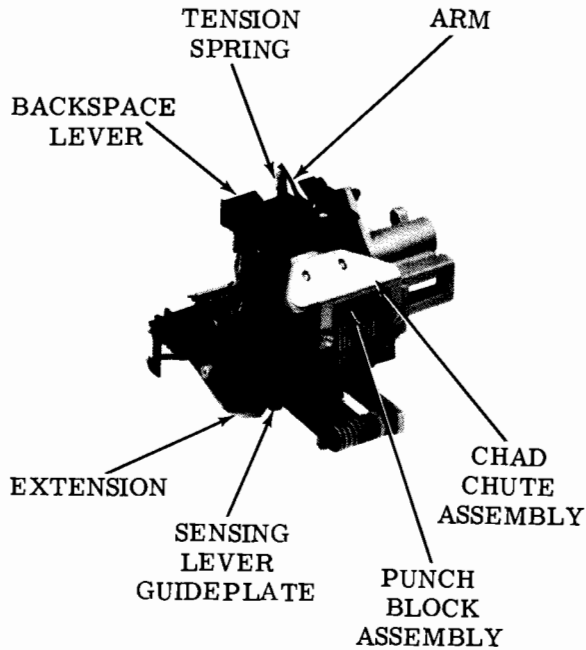

(Left Front View)

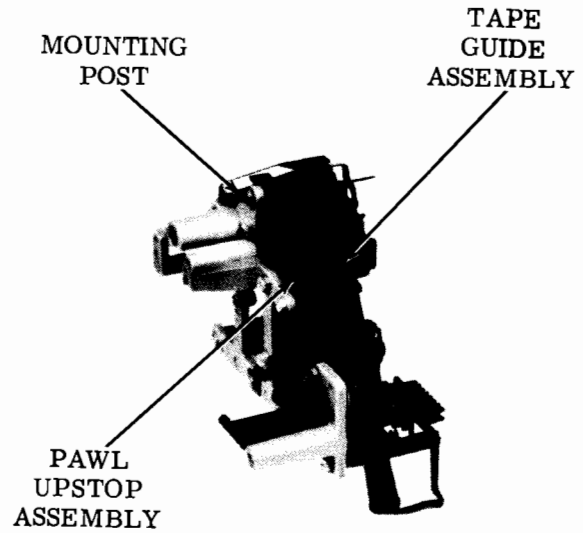

(Right Rear View)

Figure 1 - Tape Punch (Cover Removed, Early Design)

Figure 2 - Tape Punch (Cover Removed, Early Design)

- (a) Remove the TP182915 extension.
- (b) Remove two TP152893 screws, TP110743 lockwashers, and TP2034 flat washers.
- (c) Remove the TP182908 chad chute assembly.
- (d) To replace the chad chute assembly, reverse the procedure used to remove it. Line up the oblong holes of the plate with the holes in the punch block holder. Apply finger pressure on top of the chad chute assembly towards punch block holder when replacing and tightening the two screws.

- (b) Slide the punch block assembly forward until the tongue in the punch block holder and the punch pins disengage the groove in the TP182903 tape punch casting and the TP182813 levers respectively.
- (c) To replace the punch block assembly, position the slots in the punch pins so that they face the guide pin. The bottom of the punch pins should be in line and in a position that approximates their position when on the tape punch. Line up the punch pin slots with their levers and reverse the procedure used to remove the punch block assembly.

Note: Late design units have a TP185891 plastic chad chute assembly that should not be removed.

PUNCH BLOCK ASSEMBLY

A. Early Design

2.02 To remove the punch block assembly (Figure 1), proceed as follows.

- (a) Remove the two TP153817 mounting screws, TP110743 lockwashers, and TP2034 flat washers.

B. Late Design

2.03 To remove punch block assembly (Figures 3 and 4), proceed as follows.

- (a) Remove the three TP153817 screws, TP110743 lockwashers, and TP2034 flat washers.
- (b) Slide the punch block assembly forward until the tongue in the punch block holder and the punch pins disengage the groove in the TP182903 tape punch casting and the TP182813 levers respectively.

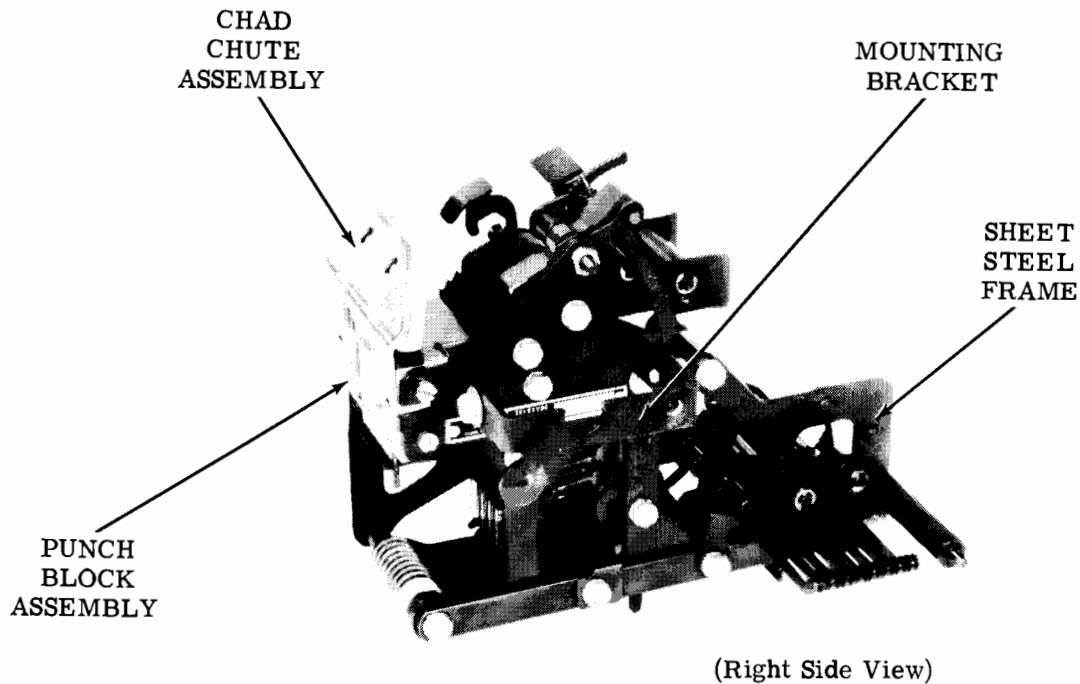

Figure 3 - Tape Punch (Cover Removed, Late Design)

(c) To replace the punch block assembly, position the slots in the punch pins so that they face the guide pin. The bottom of the punch pins should be in line and in a position that approximates their position when on the tape punch. Line up the punch pin slots with their levers and reverse the procedure used to remove the punch block assembly.

TAPE GUIDE ASSEMBLY

2.04 To remove the tape guide assembly (Figures 2 and 4), proceed as follows.

- (a) With a pencil or suitable marking instrument, mark the notch where the TP184095 tension spring end is positioned.
- (b) Unhook the TP184095 tension spring and remove the TP182936 arm from the TP182845 post.
- (c) Remove the TP181244 mounting screw from the tape guide assembly.

(d) Remove the tape guide assembly.

(e) To replace the tape guide assembly, reverse the above procedure making sure that the tension spring is positioned in the marked notch of the arm.

PAWL UPSTOP ASSEMBLY

2.05 To remove the pawl upstop assembly (Figures 2 and 4), proceed as follows.

Note: Never disassemble the pawl upstop assembly prior to removing the pawl, lever, and spring combinations. The slotted TP182822 plate keeps the "ball" and "socket" of the lever and pawl in full engagement.

- (a) Remove the TP181244 screw.
- (b) Remove the TP182821 post, TP182893 bracket, and TP182822 plate.
- (c) To replace the pawl upstop assembly, reverse the procedure used to remove it.

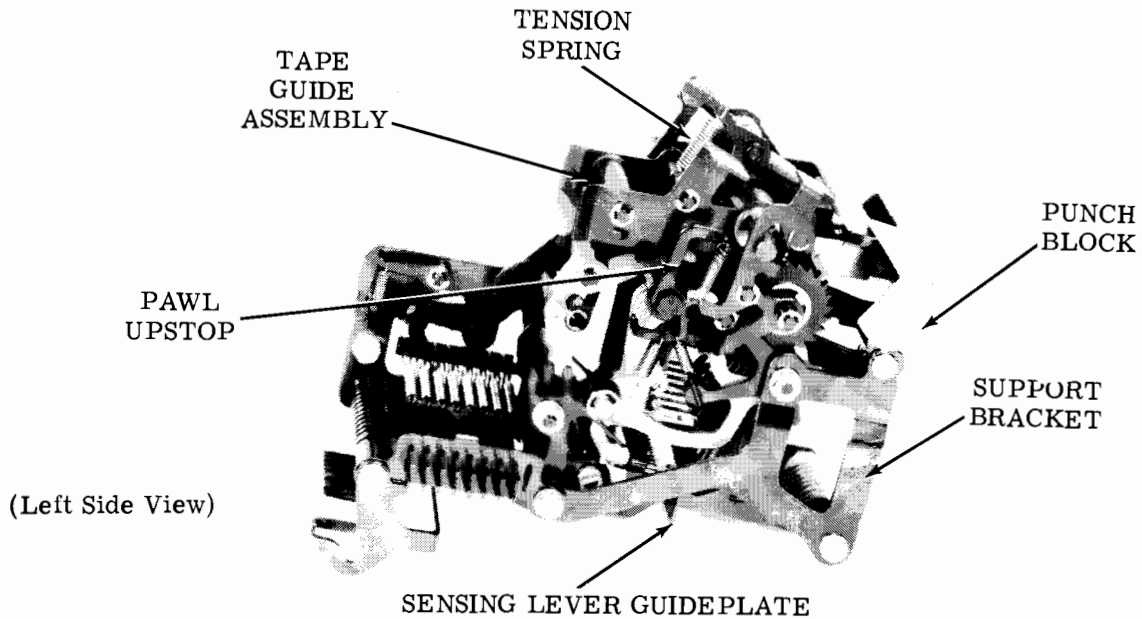

Figure 4 - Tape Punch (Cover Removed, Late Design)

SENSING LEVERS AND GUIDEPLATE ASSEMBLY

2.06 To remove the sensing levers and guideplate assembly (Figures 1 and 4), proceed as follows.

- (a) Unhook each TP182909 sensing lever spring and rotate each sensing lever away from the guideplate.
- (b) Remove the two TP181244 screws from the TP185847 post and remove the post and the attached sensing levers.
- (c) Remove the TP181242 screw and TP3598 nut from the TP182815 guideplate. Remove the guideplate.
- (d) To replace the sensing levers and guideplate, reverse the procedure used to remove them. However, before tightening the TP181242 screw and TP3598 nut, push the guideplate downward to take up all play. Viewing the tape punch from the left, position the guideplate in a horizontal to a slightly counterclockwise from horizontal position as gauged by eye. Then, tighten the TP181242 screw and TP3598 nut.

PAWL, LEVER, AND SPRING COMBINATIONS

2.07 To remove the pawl, lever, and spring combinations (Figure 4), proceed as follows.

- (a) Remove chad chute assembly.
- (b) Remove punch block assembly.
- (c) Remove tape guide assembly.
- (d) Remove pawl upstop assembly.
- (e) Remove sensing levers and guideplate assembly.
- (f) Remove the two TP181244 screws that hold the power bail mechanism in place.
- (g) Remove the TP119652 retaining ring that holds the TP182377 pawl to the power bail assembly.
- (h) Remove the TP7002 flat washer, the TP124177 lockwasher, and the TP3598 nut from the TP185846 post that supplies the pivot point for the levers.
- (i) The pawl, lever, and spring combination and the attached power bail assembly can now be removed from the tape punch.
- (j) To replace the pawl, lever, and spring combination, reverse the procedure used to remove it.

33 COVER

GENERAL DESCRIPTION

CONTENTS	PAGE
1. GENERAL	1
2. DESCRIPTION	1
A. Receive-Only (RO) Cover	1
B. Keyboard Send-Receive (KSR) Cover	1
C. Automatic Send-Receive (ASR) Cover	1

1. GENERAL

1.01 This section is reissued to provide a general description of the 33 cover. Information on the 32 cover presented in Issue 1 has been omitted and is covered in Section 574-176-100TC. Also omitted is information on adjustments, disassembly and reassembly, and lubrication which appeared in Issue 1. This information is now covered in the following sections:

- Disassembly and Reassembly - 574-100-702TC
- Adjustments - 574-126-700TC
- Lubrication - 574-126-701TC

Since this is a general revision marginal arrows have been omitted.

1.02 The main function of the cover is to protect the interior components of the set and serve as a decorative finish to the set. The cover also serves as the frame for the dial, lamps, volume control knob, and the paper supply.

1.03 References to left, right, front, or rear consider the cover as viewed by the operator.

2. DESCRIPTION

A. Receive-Only (RO) Cover

2.01 The RO cover houses the receiving component of the set. The cover is made entirely of plastic.

2.02 A spring detented lid, when raised, provides access to the ribbon. It also allows the operator to easily insert the paper around the platen. A window permits viewing the copy and provides a cutting edge for tearing paper or forms. The entire cover mounts to the set sub-base.

B. Keyboard Send-Receive (KSR) Cover

2.03 The KSR cover illustrated in Figure 1 houses the typing unit, the keyboard, and the call control unit. Like the RO cover, the KSR cover is gray and made of plastic.

2.04 The cover has a raisable lid to provide access to the paper and the ribbon as described in 2.02. In the call control area, the cover has slots for the various lamps, as shown in Figure 1, and an opening for the dial. The nameplate attaches to the front of the cover.

C. Automatic Send-Receive (ASR) Cover

2.05 The ASR cover illustrated in Figure 2 is essentially the same as the KSR except that covers for the tape punch and the tape reader are attached.

2.06 When mounted on the set the cover is one integral whole. The tape punch and the tape reader covers are attached to the main cover and remain as part of the main cover when it is removed. In the particular cover shown in Figure 2, a paper alarm is mounted to the rear of the cover beyond where the paper roll would be mounted. Like the RO and KSR covers, the ASR cover is also gray and plastic.

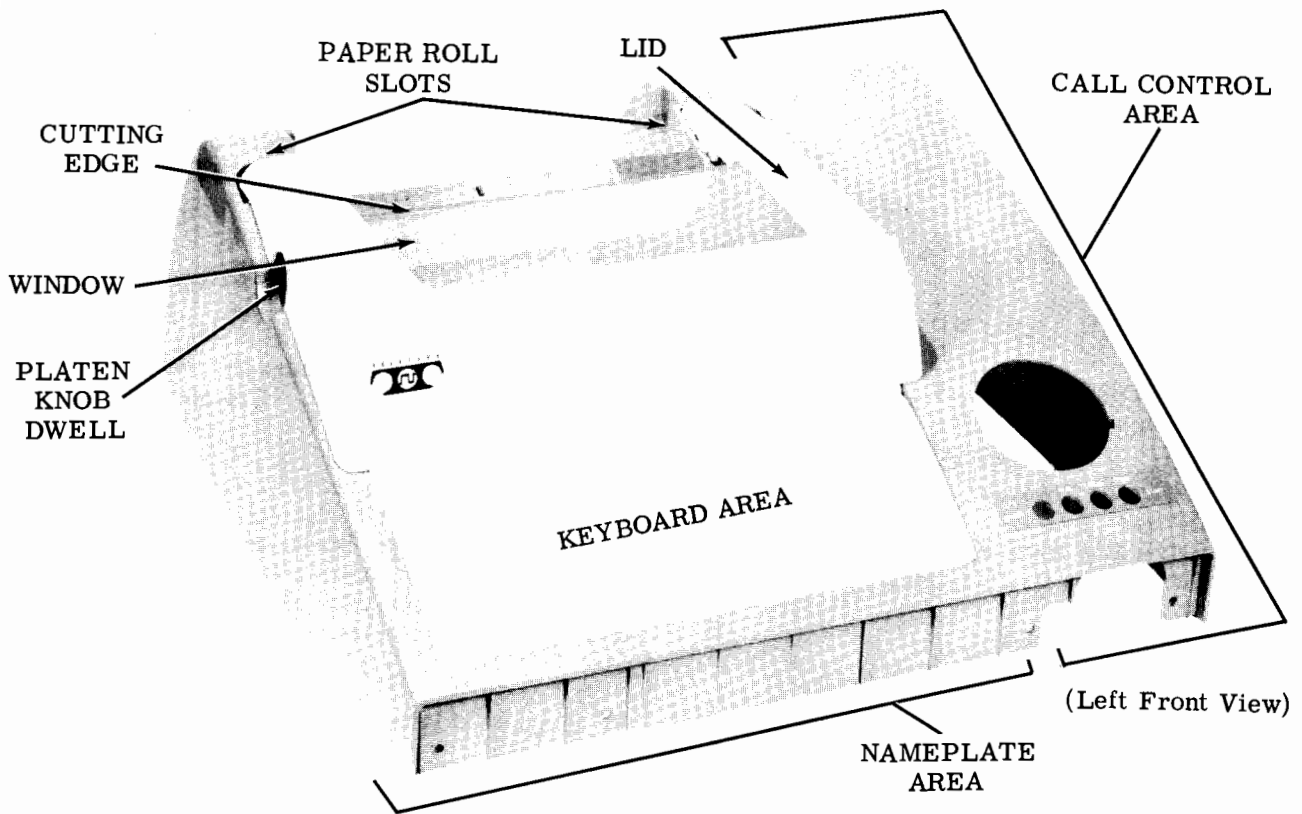

Figure 1 - Keyboard Send-Receive (KSR) Cover

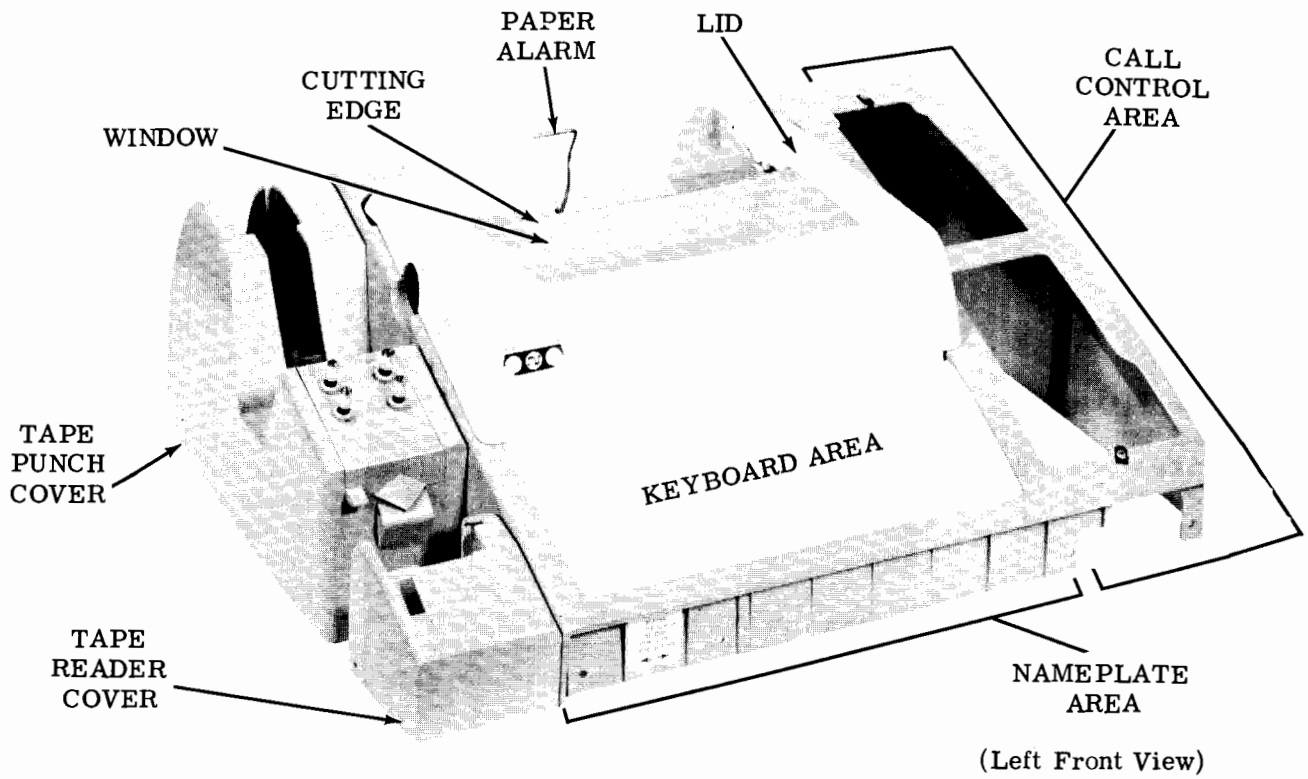

Figure 2 - Automatic Send-Receive (ASR) Cover

33 COVER

LUBRICATION

CONTENTS	PAGE
1. GENERAL.....	1
2. COVER.....	2
ASR Cover.....	2
Lid.....	2

lubricate the cover at regular unit lubrication intervals.

1.05 The textual instructions that accompany the line drawing consist of abbreviated directions, specific lubrication points, and parts affected. The meanings of the abbreviated directions (symbols) are given below:

<u>Symbol</u>	<u>Meaning</u>
D	Keep dry — no lubricant permitted.
O	Oil (KS7470)

1. GENERAL

1.01 This section provides lubrication information for the 33 cover formerly covered in Section 574-126-100TC.

1.02 The general lubrication area is shown in the automatic send-receive (ASR) cover photograph. Lubrication requirements are the same for both the keyboard send-receive (KSR) (not illustrated) and the ASR covers. The specific lubrication points are indicated on a line drawing with appropriate textual instructions keyed to the photograph by paragraph number.

1.03 Provide a thorough coat of lubricant at each designated area. Do not overlubricate to the point where lubricant drops onto adjacent parts.

1.04 Lubricate the cover before placing it into service or prior to storage. After a short period of service, relubricate it to make sure that no areas have been missed. Thereafter,

CAUTION: DO NOT USE ALCOHOL, MINERAL SPIRITS, OR OTHER SOLVENTS TO CLEAN ANY PLASTIC PARTS OR PARTS WITH PROTECTIVE DECORATIVE FINISHES. NORMALLY, A SOFT, DRY CLOTH SHOULD BE USED TO REMOVE DUST, OIL, GREASE, OR OTHERWISE CLEAN PARTS OR SUBASSEMBLIES. IF NECESSARY, A SOFT DAMP CLOTH WITH SOAP OR A MILD DETERGENT MAY BE USED. AFTERWARDS, RINSE EACH CLEANED PART OR SUBASSEMBLY WITH A SOFT, DAMP CLOTH, AND BUFF WITH A SOFT, DRY CLOTH.

1.06 Tools and materials needed for lubrication are listed in Section 570-005-800TC.

1.07 For disassembly and reassembly information, refer to Section 574-126-702TC.

2. COVER

2.01 ASR Cover

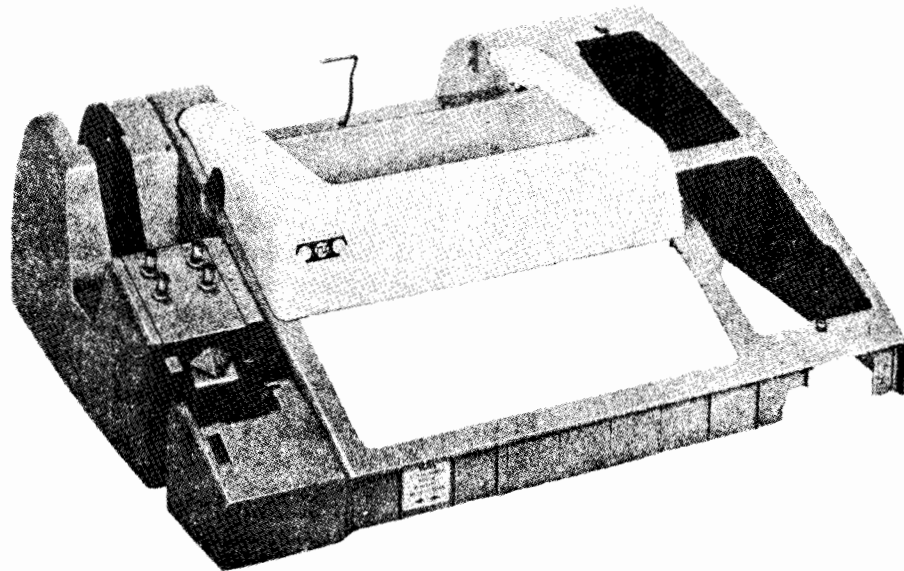

2.02 Lid

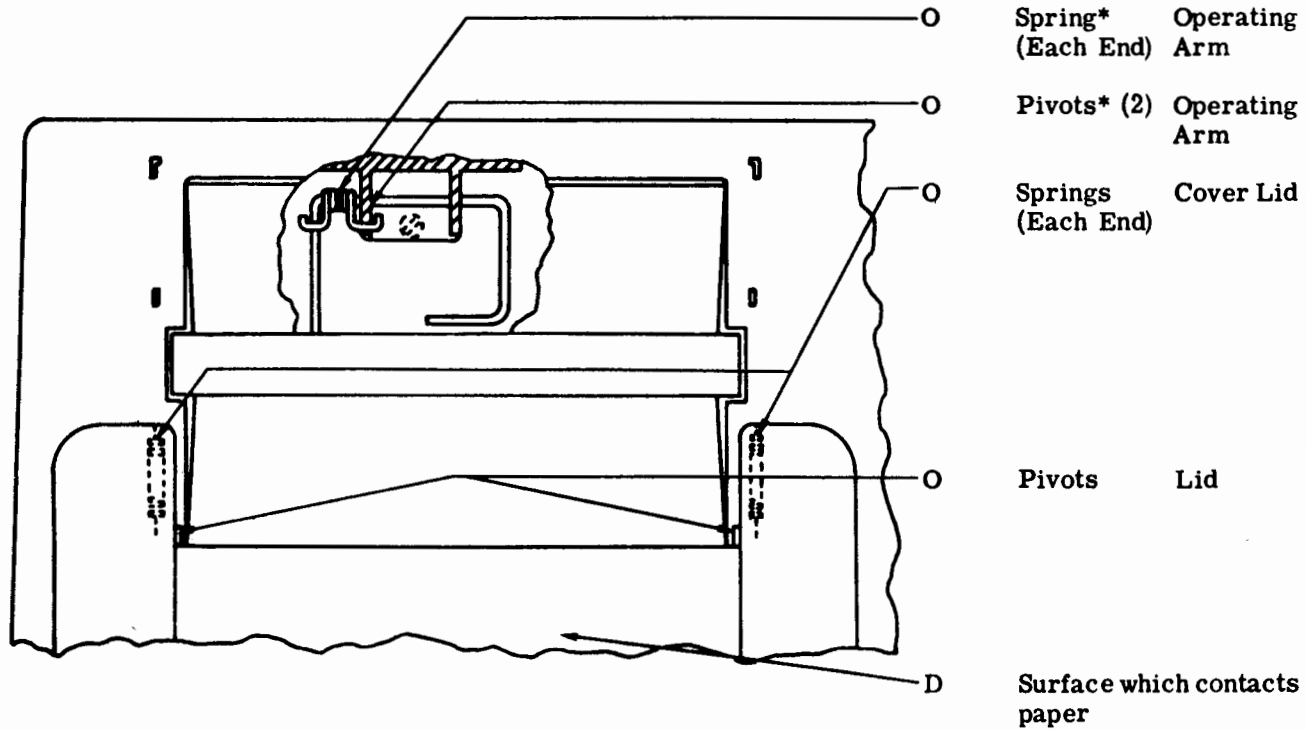

(Top View)

*For covers equipped with TP181441 switch only.