

OPERATING AND SERVICE MANUAL

2752A

TELEPRINTER

Serial Numbers Prefixed: 630-, 1302-



Note

This manual is available separately as HP part no. 02752-9004 or with the Teletype Corporation ASR 33 manual as HP part no. 02752-9002.

HP Computer Museum
www.hpmuseum.net

For research and education purposes only.

TABLE OF CONTENTS

Section	Page	Section	Page
I			
GENERAL INFORMATION		3-15.	Punch Tape from Typewriter 3-1
1-1.	Introduction 1-1	3-17.	Read Punched Tape 3-1
1-3.	General Description 1-1	3-19.	Duplicate Punched Tape 3-1
1-7.	Identification 1-1		
1-11.	Equipment Supplied 1-1	IV	THEORY OF OPERATION
1-13.	Options 1-1	4-1.	Introduction 4-1
1-15.	Specifications 1-1	4-3.	ASCII Data Code 4-1
II		4-6.	Functional Description 4-1
INSTALLATION		4-8.	Keyboard 4-1
2-1.	Introduction 2-1	4-11.	Printer 4-1
2-3.	Unpacking and Inspection 2-1	4-14.	Tape Reader 4-1
2-5.	Preparation for Use 2-1	4-16.	Tape Punch 4-1
2-7.	Assembly Procedure 2-1	4-18.	Detailed Circuit Description 4-1
2-9.	Teleprinter Ribbon, Paper and Tape Loading 2-2	4-21.	Power Supply and Motor Control Circuit 4-2
2-11.	Power and Signal Cable Connections 2-2	4-24.	Selector Magnet Driver Circuit 4-2
2-14.	Installation Checkout 2-3	4-27.	Distributor Circuit 4-2
2-16.	Shipping and Storage Instructions 2-3	4-29.	Reader Control Circuit 4-2
III		V	MAINTENANCE
OPERATION		5-1.	Introduction 5-1
3-1.	Introduction 3-1	5-3.	Preventive Maintenance 5-1
3-3.	Operating Controls 3-1	5-7.	Adjustments 5-1
3-5.	Operating Instructions 3-1	5-9.	Troubleshooting 5-1
3-7.	Print from Computer 3-1		
3-9.	Print and Punch from Computer 3-1	VI	REPLACEABLE PARTS
3-11.	Type Into Computer 3-1	6-1.	Introduction 6-1
3-13.	Read Tape Into Computer 3-1	6-3.	Ordering Information 6-1

LIST OF ILLUSTRATIONS

Figure	Title	Page	Figure	Title	Page
1-1.	Hewlett-Packard 2752A Teleprinter	1-0	2-2.	Power Pack Installation	2-2
2-1.	Carriage and H-Plate Tiedown Points	2-1	3-1.	Operating Controls	3-2

LIST OF ILLUSTRATIONS (Continued)

Figure	Title	Page	Figure	Title	Page
4-1.	Distributor Simplified Schematic Diagram	4-2	5-11.	Troubleshooting Flowchart, Runs Open (LOCAL Position) with Selector Open	5-13
5-1.	Troubleshooting Flowchart, Unit Dead with Switch Set to LOCAL	5-5	5-12.	Troubleshooting Flowchart, Runs Open (LOCAL Position) with Selector Closed	5-15
5-2.	Troubleshooting Flowchart, Key Will Not Return	5-6	5-13.	Troubleshooting Flowchart, Runs Open (LOCAL Position) with Reader On	5-15
5-3.	Troubleshooting Flowchart, Double Line Spacing	5-6	5-14.	Tape Reader Advances Tape Incorrectly	5-16
5-4.	Troubleshooting Flowchart, Unit Will Not Produce Any Functions	5-6	5-15.	Troubleshooting Flowchart, Prints when Function Is Selected	5-16
5-5.	Troubleshooting Flowchart, No Carriage Return	5-7	5-16.	Troubleshooting Flowchart, Tape Reader Reading Improperly	5-17
5-6.	Troubleshooting Flowchart, Noisy Motor	5-8	5-17.	Troubleshooting Flowchart, No Spacing at Left Margin	5-17
5-7.	Troubleshooting Flowchart, Double Printing	5-9	5-18.	Troubleshooting Flowchart, No Spacing	5-18
5-8.	Troubleshooting Flowchart, No Line Feed	5-9	5-19.	Troubleshooting Flowchart, Tape Reader Will Not Read	5-19
5-9.	Troubleshooting Flowchart, Cannot Print or Punch from Keyboard	5-10	5-20.	Reader Control Card, Parts Location Diagram	5-20
5-10.	Troubleshooting Flowchart, Prints Improper Symbols	5-11	5-21.	Teletypewriter Schematic Diagram	5-21

LIST OF TABLES

Table	Page	Table	Page		
1-1.	Teletypewriter Specifications	1-2	6-1.	Replaceable Parts Cross Reference	6-2
5-1.	Preventive Maintenance Procedures	5-2	6-2.	Reference Designations and Abbreviations	6-6
5-2.	Troubleshooting Flowchart Selection	5-4	6-3.	Code List of Manufacturers	6-7
5-3.	Reader Control Card Replaceable Parts	5-20			

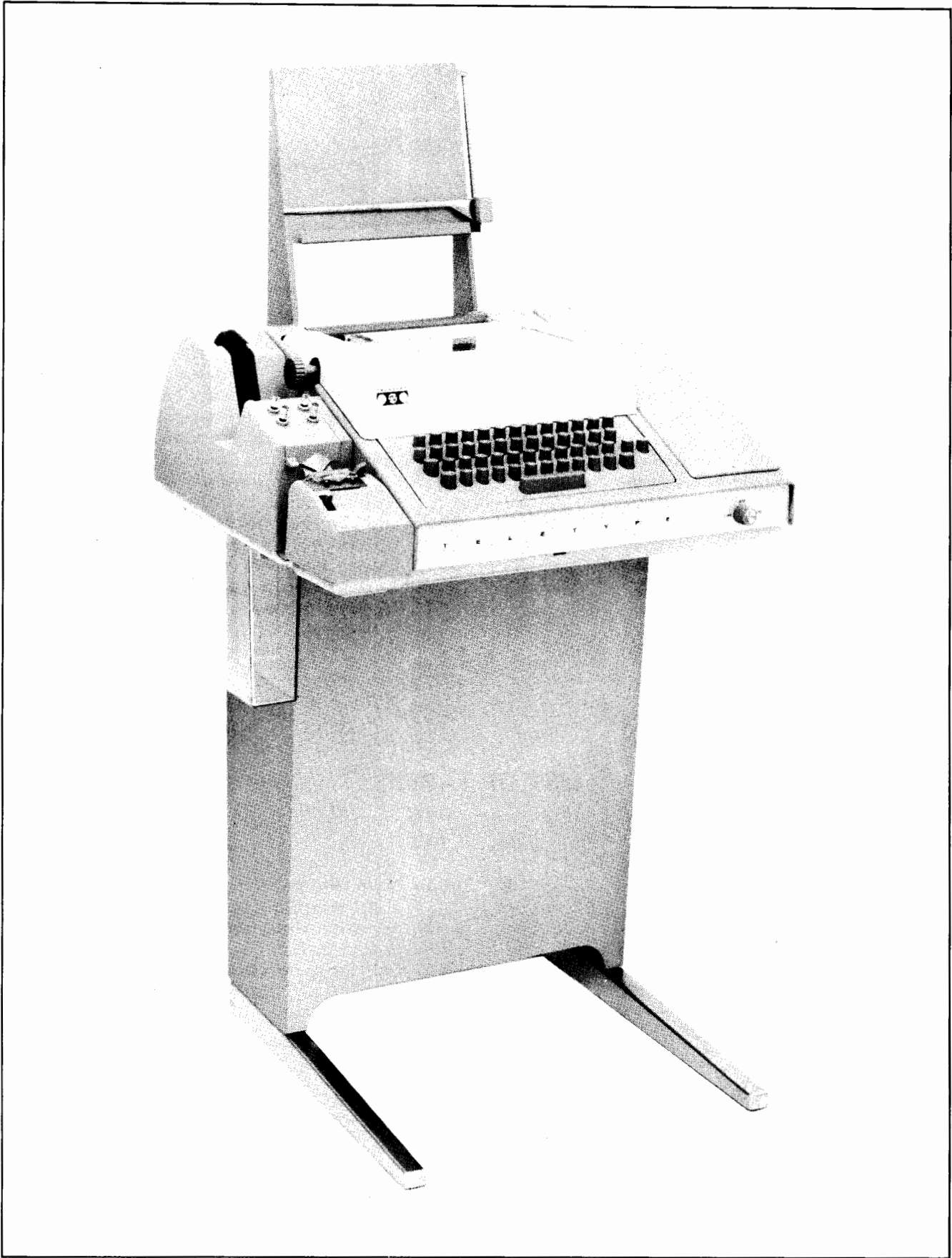

2089-23

Figure 1-1. Hewlett-Packard 2752A Teleprinter

SECTION I

GENERAL INFORMATION

1-1. INTRODUCTION.

1-2. This operating and service manual contains general information, installation and operating procedures, theory of operation, maintenance instructions, and replaceable parts lists for the Hewlett-Packard 2752A Teleprinter.

1-3. GENERAL DESCRIPTION.

1-4. The HP 2752A Teleprinter is a modified Teletype ASR33-3320/3JC** Teletypewriter Set. The teleprinter is made up of a typewriter, a paper tape punch, and a paper tape reader. The unit provides a means for loading data into a computer or other remote device by either manually operating the typewriter keyboard or by reading a punched paper tape in the teleprinter tape reader. The unit can also record received data by punching the data on a paper tape and/or typing the data on paper.

1-5. The modifications to the Teletype ASR33-3320/3JC** Teletypewriter Set make the basic unit compatible with Hewlett-Packard computers. The changes include the addition of a printed-circuit card assembly, an elapsed time indicator, a computer interface cable, and associated wiring changes.

1-6. Detailed information for the basic unit is given in the three-volume Teletype manual, which is available either separately or as a part of this manual. In cases where information in this manual differs from the information in the Teletype manual, follow this manual. Differences occur in unpacking and installation instructions and in specified maintenance intervals.

1-7. IDENTIFICATION.

1-8. Hewlett-Packard uses four digits and a letter (0000A) for standard unit model designations. Options installed as factory modifications to a standard unit are identified by a three digit suffix following the model designation (0000A-000). If the model number on your unit does not agree with that on the title page of this manual, there are differences between your unit and the unit described in this manual. These differences are described in manual supplements available at the nearest HP Sales and Service Office.

1-9. A two-section eight-digit serial number (000-00000) identifies each unit. The first three digits are a prefix number used to identify a particular unit configuration. This prefix does not change unless unit changes are made. The last five digits identify each specific unit. If the serial number prefix on your unit does not agree with that shown on the title page of this manual, there are differences between your unit and the unit described in this manual. These differences are described in manual supplements available at the nearest HP Sales and Service Office.

1-10. Printed-circuit card revisions are identified by a letter, a date code, and a division code stamped on the board (e.g., A-1055-22). The letter code identifies the version of the etched trace pattern on the unloaded board. The date code (middle digits) refers to the electrical characteristics of the loaded board. The division code (last two digits) identifies the Hewlett-Packard division that manufactured the board. If the date codes stamped on the printed-circuit boards do not agree with the date code shown on the schematic diagrams in this manual, there are differences between your boards and the boards described in this manual. These differences are described in manual supplements available at the nearest HP Sales and Service Office.

1-11. EQUIPMENT SUPPLIED.

1-12. Equipment supplied with each teleprinter includes one roll of teleprinter paper (part number 9280-0292), one roll of paper tape (part number 9280-0063), and a lubrication kit (part number 5080-6610).

1-13. OPTIONS.

1-14. The teleprinter may include option 001 or option 003 to allow operation from 230-volt, 50-hertz power or 115-volt, 50-hertz power, respectively. Both options include a Teletype ASR33-3320/3WE* instead of a standard ASR33-3320/3JC Teletypewriter Set, and option 001 includes a separate power transformer.

1-15. SPECIFICATIONS.

1-16. Table 1-1 lists technical specifications for the teleprinter.

* ASR33-TAC for teleprinter serial nos. prefixed 630
 ** ASR33-TZ for teleprinter serial nos. prefixed 630.

Table 1-1. Teleprinter Specifications

<p>Tape Punching and Reading Speed: 10 characters per second.</p> <p>Typing Speed: 100 words per minute (maximum).</p> <p>Tape Code: Eight-channel on one-inch paper tape.</p> <p>Data Transfer: Bit serial, eight-bit code.</p> <p>Platen: Friction feed.</p> <p>Power Required: 115 volts \pm 10%, 60 \pm 0.5 Hz, single-phase, 230 watts. Option 001: 230 volts \pm 10%, 50 \pm 0.5 Hz, 230 watts.</p>	<p>Power Supplied by Computer: +12 volts and -12 volts dc.</p> <p>Operating Conditions (limits imposed by paper tape): Ambient Temperature: 10° to 40° C (50° to 104° F). Relative Humidity: 20 to 80% within temperature range above.</p> <p>Dimensions: 33 inches (838 mm) high, 25-1/2 inches (648 mm) wide, 18-1/2 inches (470 mm) deep.</p> <p>Weight (with stand): Net: 77 lb (34,7 kg). Shipping: 92 lb (41, 8 kg).</p>
---	--

SECTION II

INSTALLATION



2-1. INTRODUCTION.

2-2. This section provides information on unpacking, inspection, shipping, and installation for the teleprinter.

2-3. UNPACKING AND INSPECTION.

2-4. If the shipping carton is damaged upon receipt, request that the carrier's agent be present when the unit is unpacked. Inspect the unit for damage (scratches, dents, broken parts, etc.). If the unit is damaged and fails to meet specifications, notify the carrier and the nearest Hewlett-Packard Sales and Service Office immediately. (Sales and Service Offices are listed at the back of this manual.) Retain the shipping container and the padding material for the carrier's inspection. The Hewlett-Packard Sales and Service Office will arrange for the repair or replacement of the damaged unit without waiting for any claims against the carrier to be settled.

2-5. PREPARATION FOR USE.

2-6. Since the teleprinter is shipped partially disassembled, the unit must be assembled before use. The following paragraphs contain an assembly procedure and

procedures for loading tape, typewriter ribbon, and paper in the teleprinter.

2-7. ASSEMBLY PROCEDURE.

2-8. To assemble the teleprinter, proceed as follows:

a. Place the teleprinter, with shipping pallet attached, on a workbench. Remove the seven screws on underside of pallet and lift unit from pallet. Remove tape that holds teleprinter cover in place.

b. Remove knob from front-panel LINE/OFF/LOCAL switch by pulling knob straight out. Remove nameplate containing LINE/OFF/LOCAL nomenclature by pulling nameplate down and out.

c. Unfasten teleprinter cover by removing the four screws that were uncovered when nameplate was removed, the three screws on rear of unit, and the small screw on the lower rear edge of the tape reader cover. Carefully remove teleprinter cover.

d. Remove and discard the material that is used to tie the printing carriage to the left side of the typing unit and the H-plate to the right side of the typing unit. (See figure 2-1.)

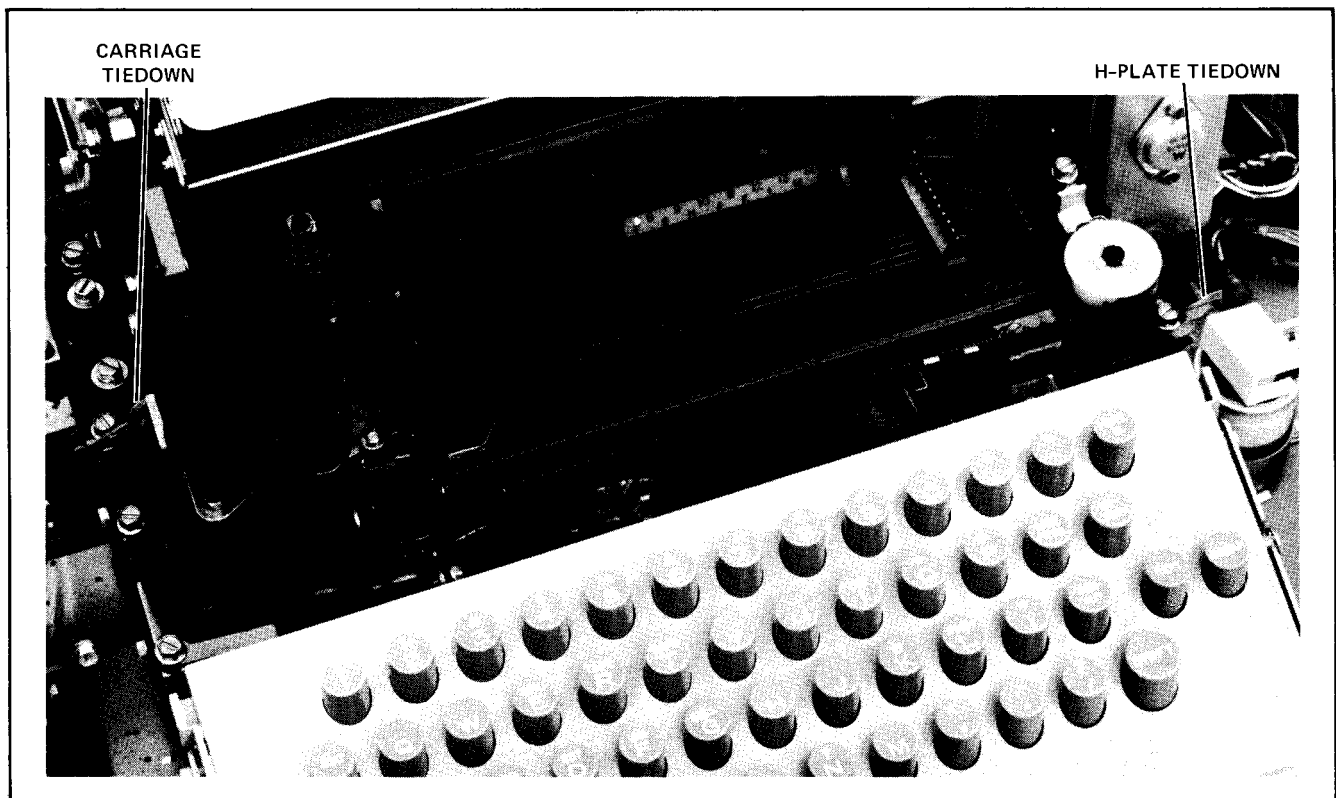
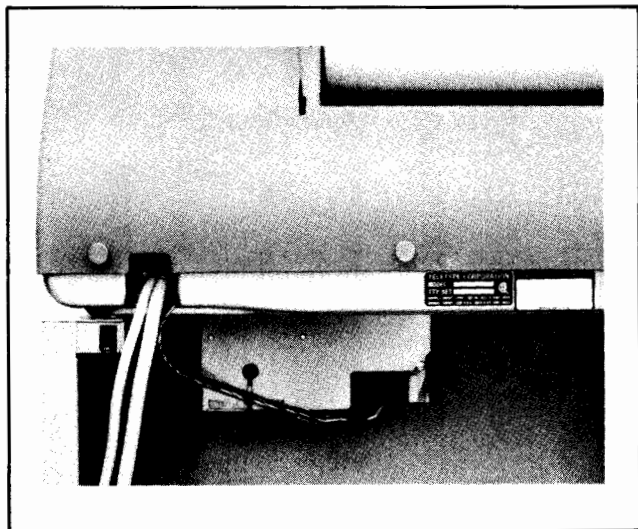

Figure 2-1. Carriage and H-Plate Tiedown Points

- e. Visually inspect the teleprinter for obvious defects.
- f. Remove the two screws at top of teleprinter stand rear panel. Remove panel by lifting panel up and out. Remove the four screws and washers from bag attached to the teleprinter stand.
- g. Support front of teleprinter and position unit on stand so teleprinter and stand rear panels are vertically aligned. Attach teleprinter to stand by inserting the four screws into teleprinter base through the holes in stand. Use a single washer for each screw. Level stand by adjusting leveling screws under rear corners of stand.
- h. Clip tape reader power pack to the inside top-front flange of stand as shown in figure 2-2. Connect short cable with transparent covering to power pack connector. (Teleprinters with serial numbers prefixed 630 and below only.)
- i. Mount step-down transformer (option 001 instruments only) to inside bottom of stand with suitable hardware. Insert teleprinter power plug in receptacle on transformer.
- j. Replace stand rear panel and secure in place with screws previously removed. Replace teleprinter cover and secure in place with screws removed in step "c".
- k. Place the long paper-roll spindle in the slots behind typewriter platen and place the small paper-roll spindle in holder directly behind tape punch. Replace platen knob.
- l. Mount copy holder on back of teleprinter by inserting copy holder tabs into matching slots on teleprinter. Push down on holder until tabs are fully seated.



2089-26

Figure 2-2. Power Pack Installation (serial prefixed numbers 630 and below only)

m. Mount chad box under tape punch by inserting back of chad box flange between stand and teleprinter base. Push chad box to rear of stand until lip on front of box touches stand.

n. Replace nameplate on front of teleprinter. Make certain that top edge of nameplate is behind the small lip on cover and that bottom of nameplate rests on top of the two projections on the teleprinter base. Push knob onto shaft of LINE/OFF/LOCAL switch and set switch to OFF position.

2-9. TELEPRINTER RIBBON, PAPER, AND TAPE LOADING.

2-10. Install teleprinter ribbon (part no. 9282-0079) according to instructions given in paragraphs 3.07 thru 3.10 of section 574-100-201 in volume 1 of the Teletype manual. Install paper (part no. 9280-0292) according to instructions given in paragraphs 3.11 thru 3.15 of section 574-100-201 in volume 1 of the Teletype manual. Install paper tape (part no. 9280-0063) as follows:

- a. Connect teleprinter power cable to appropriate power source.
- b. Press tape punch ON pushbutton.
- c. Drop new tape reel into tape punch with end of tape coming up from the rear and extending over the top of roll.
- d. Thread beginning of tape as far as possible into tape punch head.
- e. Set LINE/OFF/LOCAL switch to LOCAL and press HERE IS key several times until tape feeds through tape punch.

2-11. POWER AND SIGNAL CABLE CONNECTIONS.

2-12. The standard teleprinter plugs directly into a 115-volt 60-hertz power outlet. The teleprinter equipped with option 001 includes a step-down transformer to convert 230-volts to 115-volts. The step-down transformer power cord plugs directly into the 230-volt 50-hertz outlet, and the teleprinter power cord plugs into the transformer.

2-13. A single signal cable is provided with the teleprinter for interfacing the teleprinter to the computer. The free end of the signal cable is equipped with a hooded connector. When installing the teleprinter, pass the hooded connector through the opening in the back of the computer and plug onto the interface card for the teleprinter.

d. Thread beginning of tape as far as possible into tape punch head.

e. Set LINE/OFF/LOCAL switch to LOCAL and press HERE IS key several times until tape feeds through tape punch.

2-11. POWER AND SIGNAL CABLE CONNECTIONS.

2-12. The standard teleprinter plugs directly into a 115-volt 60-hertz power outlet. The teleprinter equipped with option 001 includes a step-down transformer to convert 230-volts to 115-volts. The step-down transformer power cord plugs directly into the 230-volt 50-hertz outlet, and the teleprinter power cord plugs into the transformer.

2-13. A single signal cable is provided with the teleprinter for interfacing the teleprinter to the computer. The free end of the signal cable is equipped with a hooded connector. When installing the teleprinter, pass the hooded connector through the opening in the back of the computer and plug onto the interface card for the teleprinter.

2-14. INSTALLATION CHECKOUT.

2-15. The following paragraphs provide a quick check of the teleprinter's basic operating functions. The checkout consists of a sample message that is typed and simultaneously punched on paper tape. The paper tape is then placed in the tape reader, and the message is printed again from the tape. Both printed messages must be exactly alike. Perform the checkout as follows:

a. Verify that teleprinter power cable is connected to power outlet (115-volt 60-Hz for standard unit; 230-volt 50-Hz for option 001).

b. Turn LINE/OFF/LOCAL switch to LOCAL and press tape punch ON pushbutton.

c. Using the typewriter keyboard, type the following message:

THE QUICK BROWN FOX JUMPED OVER THE
LAZY DOG'S BACK 1234567890.

Press RETURN key, press LINE FEED key, and then type the message again. The tape punch should simultaneously punch the message into the tape.

d. The printed message should be exactly as typed. If it is not, the typing unit is malfunctioning. Refer to Teletype manual and repair unit before proceeding to step "e".

e. Press HERE IS key to generate about six inches of blank tape. Remove the newly punched tape and insert tape into tape reader.

f. Set tape reader control lever to START. The tape reader should read the tape, and the typewriter unit should print the message exactly as it was originally typed; if not, the tape punch or tape reader is malfunctioning. Refer to Teletype manual and repair the unit.

g. If any repairs were required, repeat all steps of this checkout procedure to ensure proper operation.

2-16. SHIPPING AND STORAGE INSTRUCTIONS.

2-17. If the unit is to be shipped to Hewlett-Packard for service or repair, attach a tag to the unit identifying the owner and indicating the service or repair to be accomplished. Include the model number and full serial number of the unit.

2-18. Place the unit in the original container if available. If the original container is not available, a suitable container and packing material can be purchased from a local Hewlett-Packard Field Office.

2-19. If the original container is not used, wrap the unit in heavy paper and place it in an inner container. Place adequate packing material around all sides of the unit and place a cardboard strip over the front panel and keyboard. Place the unit and inner container in a heavy carton or wooden box and bind with strong tape or metal bands. Mark the shipping container "FRAGILE."

Note

In any correspondence, identify the unit by model number and serial number prefix. Refer any questions to the nearest Hewlett-Packard Field Office.

2-20. If the teleprinter is to be stored for any length of time, pack the unit as described above to protect it against accidental damage.

SECTION III

OPERATION



3-1. INTRODUCTION.

3-2. This section contains a description of the teleprinter operating controls and instructions for operating the teleprinter in various modes.

CAUTION

The teleprinter must not be used for more than five hours a day or thirty hours a week. Damage to equipment may result if limits are exceeded.

3-3. OPERATING CONTROLS.

3-4. Figure 3-1 shows the teleprinter operating controls. Numbers preceding control descriptions correspond to index numbers of the various controls.

3-5. OPERATING INSTRUCTIONS.

3-6. The following paragraphs contain instructions for operating the teleprinter in various modes. For each of these procedures, it is assumed that the teleprinter has been installed and prepared for use in accordance with section II of this manual.

3-7. PRINT FROM COMPUTER.

3-8. To print data that is output by the computer, set the LINE/OFF/LOCAL switch to LINE. The computer now has direct control of the teleprinter printing function.

3-9. PRINT AND PUNCH FROM COMPUTER.

3-10. To print and punch data from the computer, press tape punch ON pushbutton, and set LINE/OFF/LOCAL switch to LINE. The computer now has direct control over printing and tape punching functions. After use, press tape punch OFF pushbutton.

3-11. TYPE INTO COMPUTER.

3-12. To type data into the computer from the teleprinter, an indication that the computer is ready to receive data is required. When the computer indicates it is ready for data (by causing teleprinter to type READY, RUN, etc. depending on software in use), enter data directly from typewriter keyboard. If an error is made, sequentially press ESC or RUB OUT (depending on software in use), RETURN, and LINE FEED keys; the computer will disregard all data on the line containing the error.

Note

A non-printing key such as LINE FEED must follow the pressing of the RETURN key. This prevents possible printing of a character at random.

3-13. READ TAPE INTO COMPUTER.

3-14. To read punched tape into the computer, open tape lid on tape reader and insert tape. Verify that feed holes on tape match with pins on feed wheel, and close tape reader lid. Set LINE/OFF/LOCAL switch to LINE and tape reader control lever to START. After tape has been read, set control lever to STOP.

3-15. PUNCH TAPE FROM TYPEWRITER.

3-16. To punch tape from the typewriter without affecting computer memory, set LINE/OFF/LOCAL switch to LOCAL, press tape punch ON pushbutton, and type message. If an error is made, press RUB OUT, RETURN, and LINE FEED keys. The computer will ignore the erroneous line. When finished, press tape punch OFF pushbutton.

3-17. READ PUNCHED TAPE.

3-18. To read a punched tape without affecting the computer, insert tape in reader as described in paragraph 3-14. Set LINE/OFF/LOCAL switch to LOCAL and tape reader control lever to START. When the typewriter finishes typing the tape contents, set tape reader control lever to STOP.

3-19. DUPLICATE PUNCHED TAPE.

3-20. Install the tape to be reproduced in the tape reader as described in paragraph 3-14. Set LINE/OFF/LOCAL switch to LOCAL, press tape punch ON pushbutton, press HERE IS key twice to generate a tape leader, and set tape reader control lever to START. When the duplicate tape is completely punched, set tape reader control level to STOP and press HERE IS key twice to generate trailer tape. Press tape punch OFF pushbutton and return LINE/OFF/LOCAL switch to OFF.

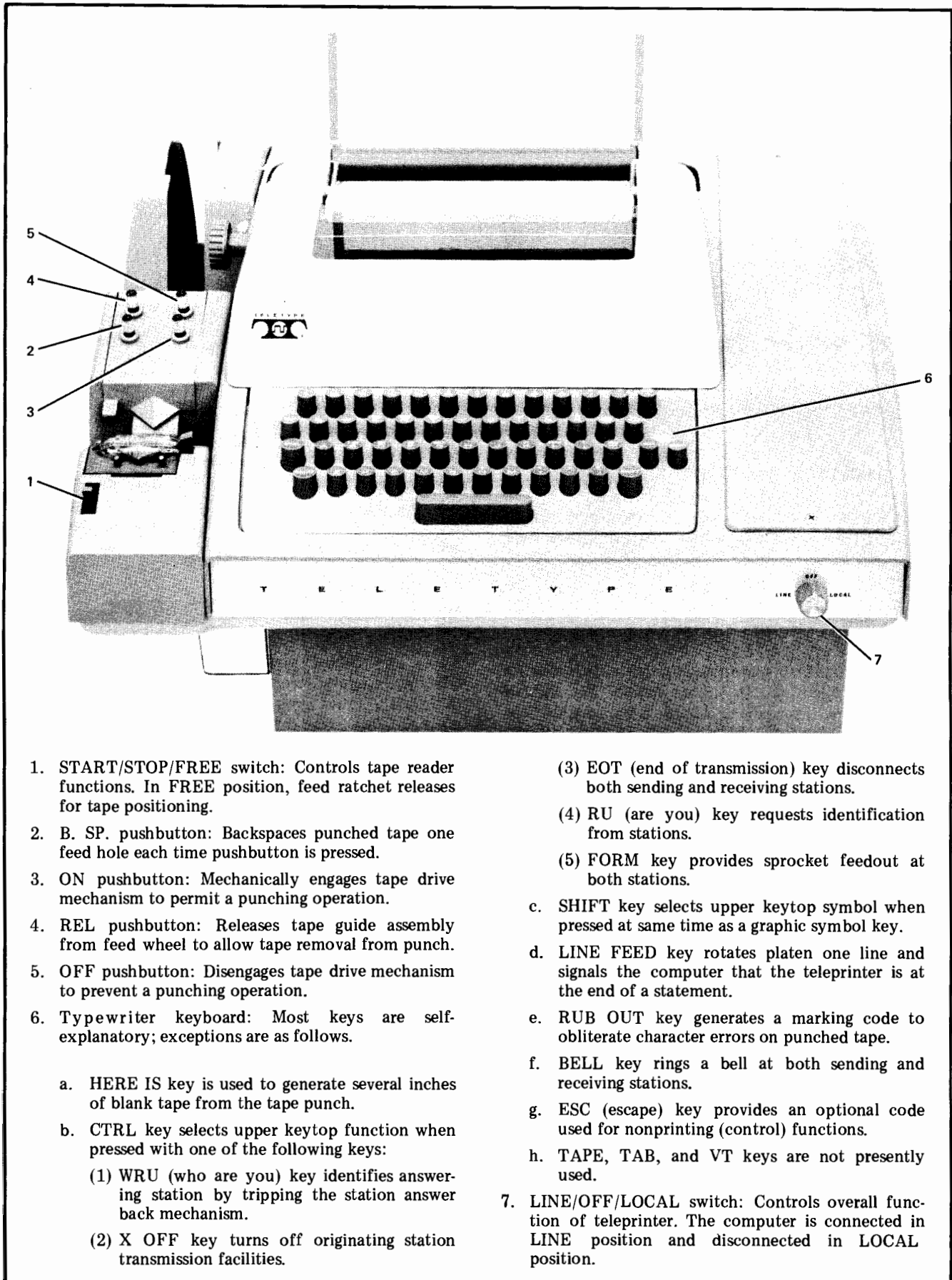

1. START/STOP/FREE switch: Controls tape reader functions. In FREE position, feed ratchet releases for tape positioning.
2. B. SP. pushbutton: Backspaces punched tape one feed hole each time pushbutton is pressed.
3. ON pushbutton: Mechanically engages tape drive mechanism to permit a punching operation.
4. REL pushbutton: Releases tape guide assembly from feed wheel to allow tape removal from punch.
5. OFF pushbutton: Disengages tape drive mechanism to prevent a punching operation.
6. Typewriter keyboard: Most keys are self-explanatory; exceptions are as follows.
 - a. HERE IS key is used to generate several inches of blank tape from the tape punch.
 - b. CTRL key selects upper keytop function when pressed with one of the following keys:
 - (1) WRU (who are you) key identifies answering station by tripping the station answer back mechanism.
 - (2) X OFF key turns off originating station transmission facilities.
 - c. SHIFT key selects upper keytop symbol when pressed at same time as a graphic symbol key.
 - d. LINE FEED key rotates platen one line and signals the computer that the teleprinter is at the end of a statement.
 - e. RUB OUT key generates a marking code to obliterate character errors on punched tape.
 - f. BELL key rings a bell at both sending and receiving stations.
 - g. ESC (escape) key provides an optional code used for nonprinting (control) functions.
 - h. TAPE, TAB, and VT keys are not presently used.
7. LINE/OFF/LOCAL switch: Controls overall function of teleprinter. The computer is connected in LINE position and disconnected in LOCAL position.

Figure 3-1. Operating Controls

SECTION IV

THEORY OF OPERATION

4-1. INTRODUCTION.

4-2. This section provides information on the American Standard Code for Information Interchange (ASCII) data code used by the teleprinter, descriptions of the teleprinter functional sections, and a detailed circuit description for the teleprinter.

4-3. ASCII DATA CODE.

4-4. ASCII data code provides an 11-bit transmission pattern. Eight bits are used to gain intelligence. When 1 start bit and 2 stop bits are added to the 8 intelligence bits, a total of 11 bits are transmitted (or received) for each character. The eight intelligence bits are provided by pressing a teleprinter key or reading a punched tape; the three start and stop bits are automatically provided by the teleprinter distributor each time a character is transmitted.

4-5. The first seven of the eight intelligence bits are used for data; the eighth bit is an error detection (parity) bit. This arrangement provides 2^7 or 128 different coding combinations. Only 64 of these combinations are used to print characters. The remaining 64 are either assigned to control (nonprinting) functions or reserved for future use.

4-6. FUNCTIONAL DESCRIPTION.

4-7. The teleprinter is made up of four basic units, each of which are described functionally in the following paragraphs.

- a. Keyboard.
- b. Printer.
- c. Tape reader.
- d. Tape punch.

4-8. KEYBOARD.

4-9. Pressing a key on the teleprinter keyboard actuates a key lever in the keyboard mechanism. The downward movement of the key lever sets up a mechanical arrangement of the codebars which selects the particular character for printing. The codebars also close keyboard contacts which complete the electrical circuit for the marking or logic 1 bits for that character.

4-10. The code combination provided by the keyboard contacts is wired in parallel to the distributor mechanism. The distributor rotates so that each segment on the distributor disc is sampled once every rotation for 9.09 milliseconds. A start bit, which is always a space or logic 0, comes first; the eight intelligence bits are next; the two stop bits, which are always marks or logic 1's, complete the cycle for one character. The distributor mechanism,

therefore, translates the parallel input from the keyboard contacts to serial format for application to the computer.

4-11. PRINTER.

4-12. The printer may be controlled from the keyboard, the tape reader, or from external signals. The printer can print characters, perform functions, such as line feed and carriage return, and control punching of data received from the keyboard, the tape reader, or the computer.

4-13. Although data is transmitted via the keyboard distributor mechanism, the printer selector mechanism must be enabled to print data received from an external device. The selector magnet driver (SMD) card enables the selector mechanism. The card does this by energizing a selector magnet for a mark condition and de-energizing the selector magnet for a space condition. The selector mechanism converts the electrical SMD output to a mechanical arrangement of the codebars that causes the received character to be printed.

4-14. TAPE READER.

4-15. The tape reader is an electromechanical device that is capable of reading an eight-level coded tape. The characters read are printed by the teleprinter and transmitted by the distributor mechanism to the computer. The reader is controlled by a START/STOP/FREE lever; when enabled, the reader generates a distributor cycle which transmits data to the computer.

4-16. TAPE PUNCH.

4-17. The tape punch is an electromechanical device that is capable of punching (storing) data on eight-level tape. The tape punch receives data from the selector mechanism in the printing unit. The selector mechanism sets up the mechanical codebar arrangement at the end of the cycle. The particular arrangement is then sensed by the tape punch sensing pins and transferred to the code punch pins, which perforate the tape. The tape punch is engaged and disengaged by the ON and OFF pushbuttons.

4-18. DETAILED CIRCUIT DESCRIPTION.

4-19. There are four major circuits in the teleprinter:

- a. Power supply and motor control circuit.
- b. Selector magnet driver (SMD) circuit.
- c. Distributor circuit.
- d. Reader control circuit.

4-20. The following paragraphs describe operation of each teleprinter circuit. Figure 5-21 provides an overall schematic diagram of the teleprinter.

4-21. POWER SUPPLY AND MOTOR CONTROL CIRCUIT.

4-22. When the LINE/OFF/LOCAL switch is set to OFF, all ac power is disconnected from the teleprinter except the ac supply to the selector magnet driver. In the LOCAL position, data cannot be transmitted or received because the line relay is de-energized. However, the teleprinter can perform typing, reading, and punching operations. Setting the switch to LINE energizes the line relay, placing the computer in the signal loop. Data from the distributor is now sent to the computer, and computer data can be received by the teleprinter through the SMD card.

4-23. Motor control is accomplished with a motor start relay and the LINE/OFF/LOCAL switch. The motor operates when the switch is set to either LINE or LOCAL.

4-24. SELECTOR MAGNET DRIVER CIRCUIT.

4-25. To print data from the computer, the computer interface card must provide ASCII coded signals to the SMD card. The SMD card provides 20 volts dc at 500 mA to drive the selector magnet coil; the coil is energized for a mark (logic 1) signal and de-energized for a space (logic 0) signal.

4-26. The computer interface card normally provides a positive level to the base of transistor Q1. The positive signal turns Q1 off and transistor Q2 on. When the start bit of a transmitted character is received (a space or logic 0), the positive level at the base of Q1 is removed and both Q1 and Q2 switch states. This de-energizes the selector magnet coil. The selector magnet attracts the armature each time a mark is received and releases the armature each time a space is received. This action mechanically arranges the codebars in the keyboard, one at a time, so that the codebars reflect the received character when the 11-bit transmission ends.

4-27. DISTRIBUTOR CIRCUIT.

4-28. A simplified schematic diagram of the distributor is shown in figure 4-1. The diagram shows keyboard

contacts supplying the code for the letter "u". Distributor inputs can also originate from the tape reader contacts or answer-back contacts since all three sources are wired in parallel. When a distributor cycle is initiated, the distributor disc segments are sampled one at a time as the rotor turns. In this manner, parallel-to-serial data conversion is accomplished.

4-29. READER CONTROL CIRCUIT.

4-30. The reader control card provides circuitry that allows the computer to remotely control the tape reader. In the absence of a read command at pin P of the computer interface cable connector, transistor Q1 is biased on, which holds transistor Q2 off. When a read command is received, Q1 turns off and Q2 turns on. This energizes the reader trip coil and closes the reader feed contact, which energizes the reader feed magnet and initiates a distributor cycle. The tape reader senses holes in a punched tape and the tape reader contacts provide the data to the distributor.

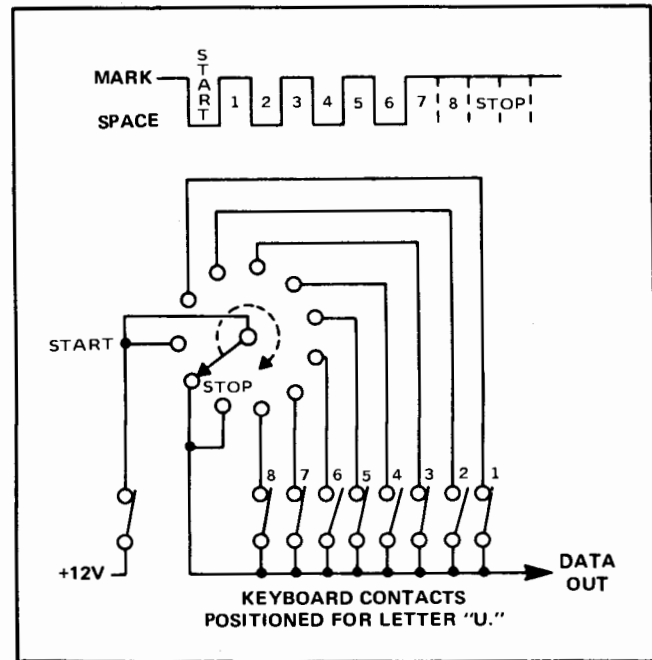

2089-21

Figure 4-1. Distributor Simplified Schematic Diagram

SECTION V

MAINTENANCE

5-1. INTRODUCTION.

5-2. This section provides preventive maintenance procedures, adjustment information, and troubleshooting information for the teleprinter. A component location photograph (figure 5-20) and parts list (table 5-3) for the reader control card and an overall schematic diagram (figure 5-21) are included in this section.

5-3. PREVENTIVE MAINTENANCE.

5-4. Table 5-1 gives step-by-step preventive maintenance procedures for the teleprinter. The procedures should normally be performed once every month or every 100 operating hours, whichever occurs first. When the teleprinter is operated in an extremely dusty environment, the procedures should be performed more frequently.

5-5. Volume I of the Teletype manual provides cleaning solvent recommendations and gives further cleaning and lubricating instructions that should be performed every 750 operating hours or 6 months, whichever occurs first. Lubrication and cleaning supplies are listed in table 6-1.

5-6. Use the teleprinter elapsed time indicator to determine hours of operating time for preventive maintenance purposes. The indicator can be observed by opening the teleprinter cover halfway and looking through the opening above the right side of the cover.

5-7. ADJUSTMENTS.

5-8. Volume II of the Teletype manual provides complete adjustment procedures for the teleprinter. Adjustments should be checked when poor performance indicates possible maladjustment.

5-9. TROUBLESHOOTING.

5-10. To isolate trouble in the teleprinter, first determine the malfunction. Then locate the malfunction symptom in table 5-2 and perform the steps in the flowchart that is listed opposite the symptom. A parts location diagram of the reader control card (figure 5-20) and an overall schematic diagram (figure 5-21) are provided as troubleshooting aids.

Note

When making any adjustment, check all related adjustments that are listed in the Teletype manual. The nine-digit section numbers on the flowcharts refer to Teletype manual sections; page numbers in parenthesis refer to older Teletype manuals. Part numbers referenced (for example, TTY 181821) are Teletype part numbers and may be found in the replaceable parts section of the Teletype manual.

Table 5-1. Preventive Maintenance Procedures

STEP	INSTRUCTIONS	TELETYPE MANUAL REFERENCE
1	Remove Line/Off/Local switch knob.	
2	Remove name plate (plate snaps off).	
3	Remove platen knob.	
4	Remove the eight screws from the teleprinter cover as follows: a. Three thumb screws on rear. b. Four screws under name plate. . c. One screw on tape reader.	Figure 1, Page 2, Section 574-100-201
5	Remove ribbon from teleprinter.	Figure 5, Page 10
6	Remove type wheel (held in place by one 3/16 in. nut).	
7	Clean type wheel in solvent and inspect for worn or damaged letters and numbers.	
8	Remove print hammer head and clean with solvent. Inspect head for wear.	
9	CAUTION Do not saturate the carriage assembly with solvent or damage to the assembly may result. Clean carriage assembly of all ink.	
10	Reinstall print hammer head.	
11	Clean platen with solvent.	
12	Clean paper guide with solvent.	
13	Clean dashpot piston with solvent.	
14	Lubricate dashpot piston with a light coat of oil.	
15	Clean inside of dash pot cylinder with solvent.	
16	Clean all associated parts of piston and dash pot cylinder with solvent.	
17	Remove the four screws that hold drive motor in place.	Figure 7, Page 10, Section 574-122-702
18	Remove retaining ring that holds pulley gear in place.	
19	Remove pulley gear.	
20	Clean pulley gear with solvent.	
21	Lubricate hollow space inside pulley gear with grease.	

Table 5-1. Preventive Maintenance Procedures (Continued)

STEP	INSTRUCTIONS	TELETYPE MANUAL REFERENCE
22	Inspect pinion gear for wear and cracks.	
23	Install pulley gear and retaining ring on motor.	
24	Inspect pulley gear and pinion gear for proper mesh.	
25	Remove fan from motor. Fan is held in place by an 8/32 in. allen screw.	
26	Clean fan with solvent and inspect for cracks. Install fan on motor.	
27	Lubricate the two oil holes on motor with three drops of oil each.	Page 17, Section 574-122-701
28	Clean the main shaft mechanism of all dust and dirt. Use a cotton swab saturated with solvent.	Figure 7, Page 10, Section 574-122-702
29	Inspect main shaft for lateral movement.	
30	Inspect drive shaft bearings for wear. Lubricate main shaft mechanism with two drops of oil where each part intersects with main shaft.	
<p data-bbox="516 1014 630 1045">CAUTION</p> <p data-bbox="277 1073 797 1125">Be sure to hook up ground wire in following step or damage to the motor may result.</p>		
31	Install drive motor.	Figure 7, Page 10, Section 574-122-702
32	Inspect drive belt for proper tension.	
33	Refer to Teletype manual for complete lubrication instructions for the keyboard.	Page 1, Section 574-121-701
34	Refer to Teletype manual for complete lubrication instructions for the typing unit.	Page 1, Section 574-122-701
35	Clean the entire reader unit with a soft brush to remove all paper dust.	
36	Lubricate reader.	Page 1, Section 574-124-701
37	Clean the tape punch with a soft brush.	
38	Remove the chad chute extension and clean. Reinstall chad chute extension.	
39	Lubricate the tape punch.	Page 1, Section 574-125-701

Table 5-2. Troubleshooting Flowchart Selection

MALFUNCTION SYMPTOM	TROUBLESHOOTING FLOWCHART
Unit dead with switch set to LOCAL.	Figure 5-1
Key will not return.	Figure 5-2
Double line spacing.	Figure 5-3
Unit will not produce any functions.	Figure 5-4
No carriage return.	Figure 5-5
Noisy motor.	Figure 5-6
Double printing.	Figure 5-7
No line feed.	Figure 5-8
Cannot print or punch from keyboard.	Figure 5-9
Prints improper symbols.	Figure 5-10
Runs open (LOCAL position) with selector open.	Figure 5-11
Runs open (LOCAL position) with selector closed.	Figure 5-12
Runs open (LOCAL position) with reader on.	Figure 5-13
Tape reader advances tape incorrectly.	Figure 5-14
Prints when function is selected.	Figure 5-15
Tape reader reading improperly.	Figure 5-16
No spacing at left margin.	Figure 5-17
No spacing.	Figure 5-18
Tape reader will not read.	Figure 5-19

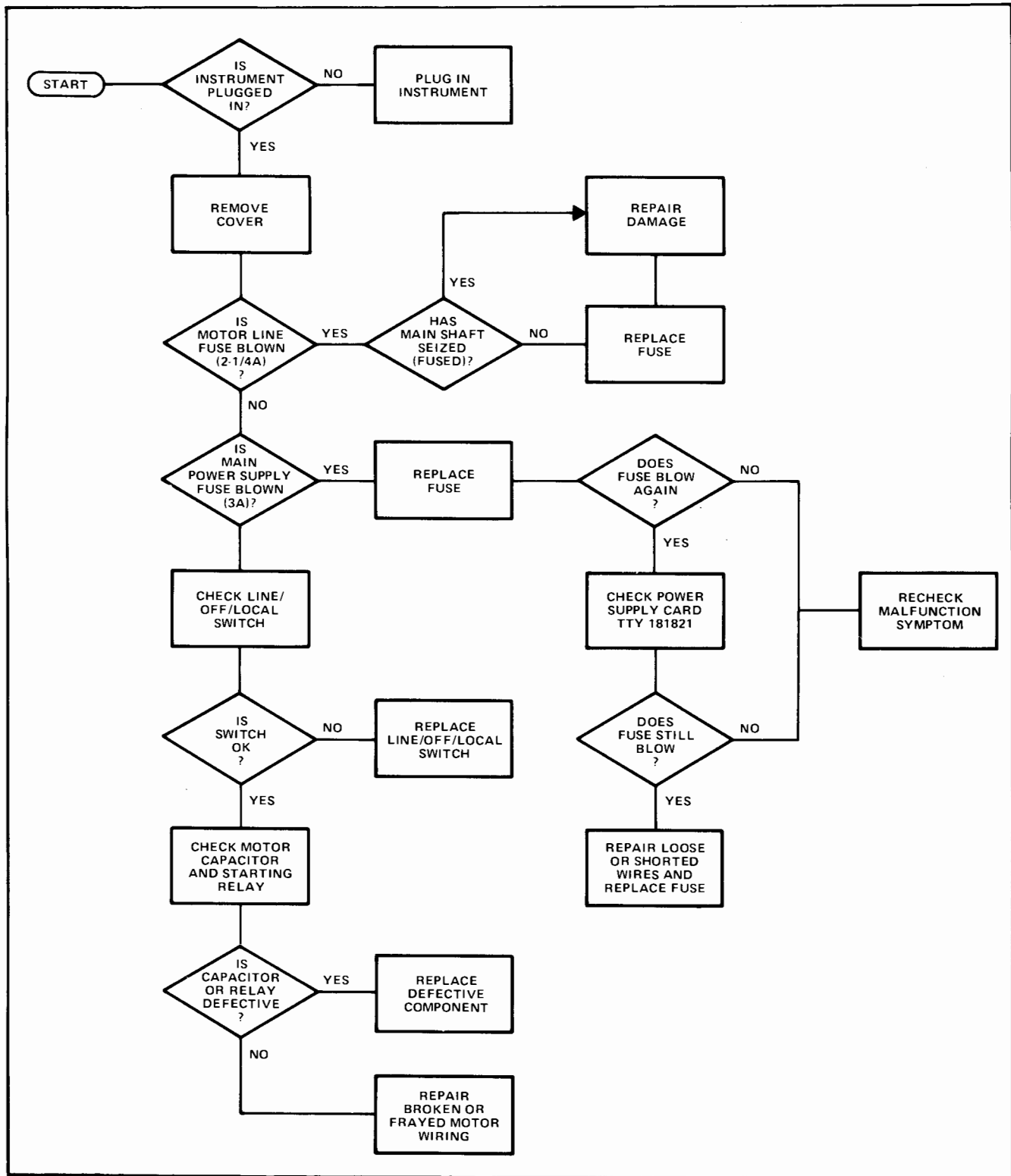

2089-2

Figure 5-1. Troubleshooting Flowchart, Unit Dead with Switch Set to LOCAL

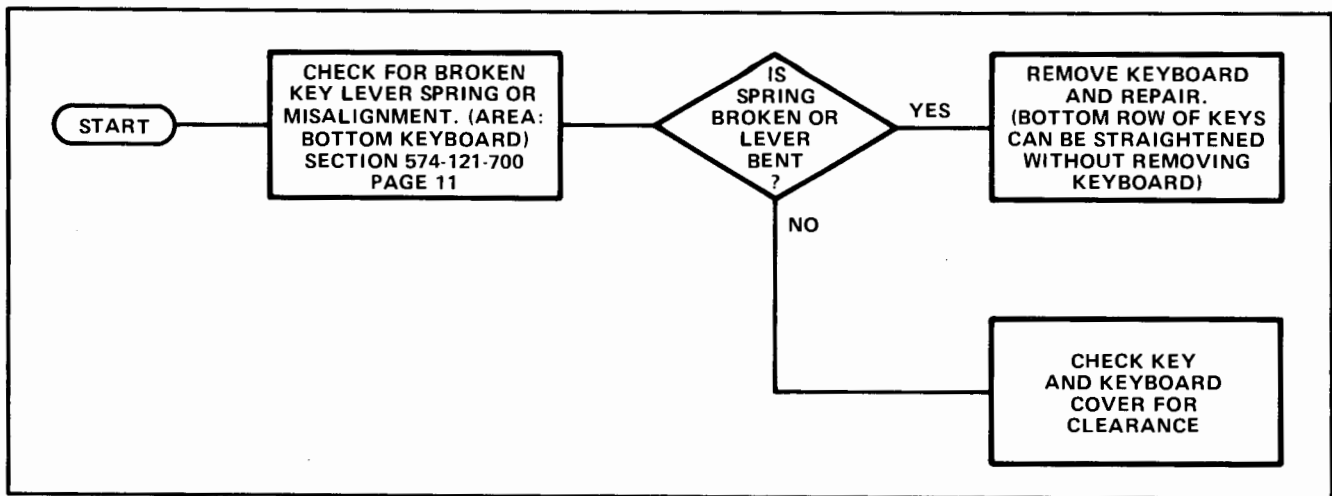

2089-4

Figure 5-2. Troubleshooting Flowchart, Key Will Not Return

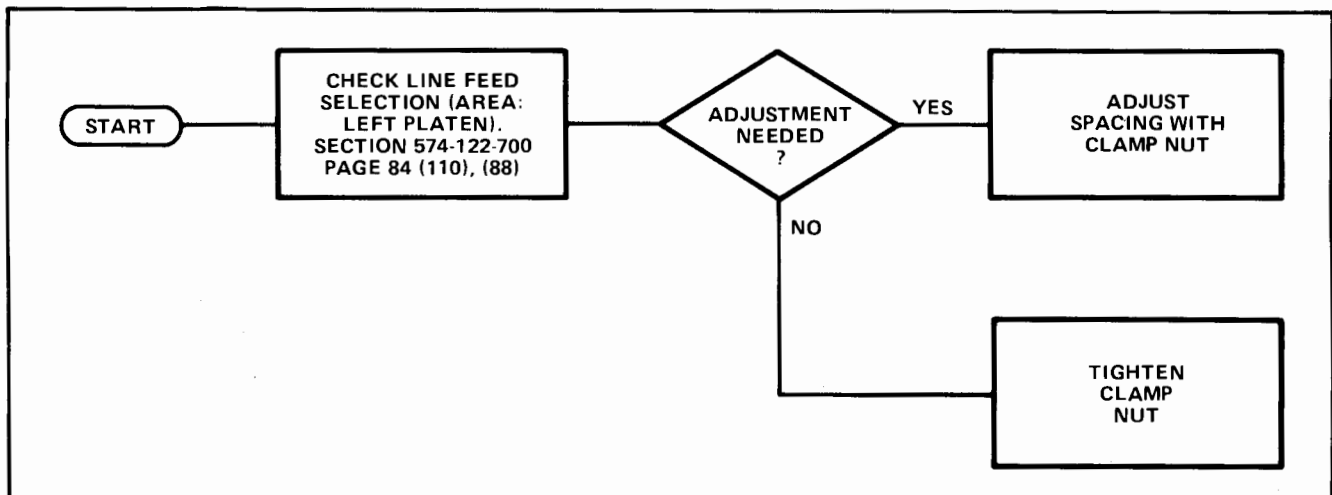

2089-5

Figure 5-3. Troubleshooting Flowchart, Double Line Spacing

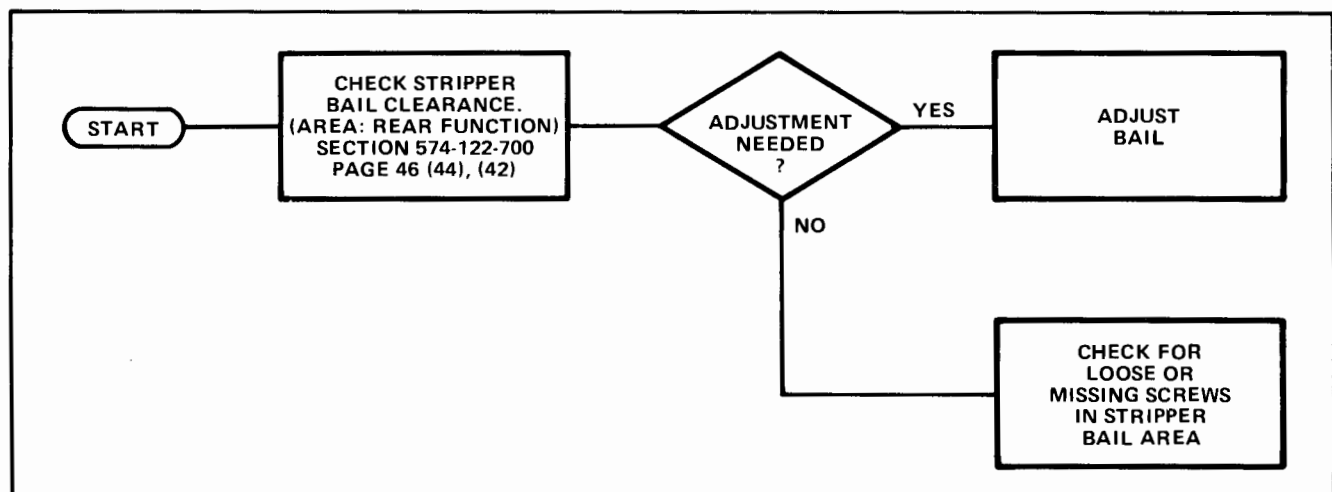

2089-6

Figure 5-4. Troubleshooting Flowchart, Unit Will Not Produce Any Functions

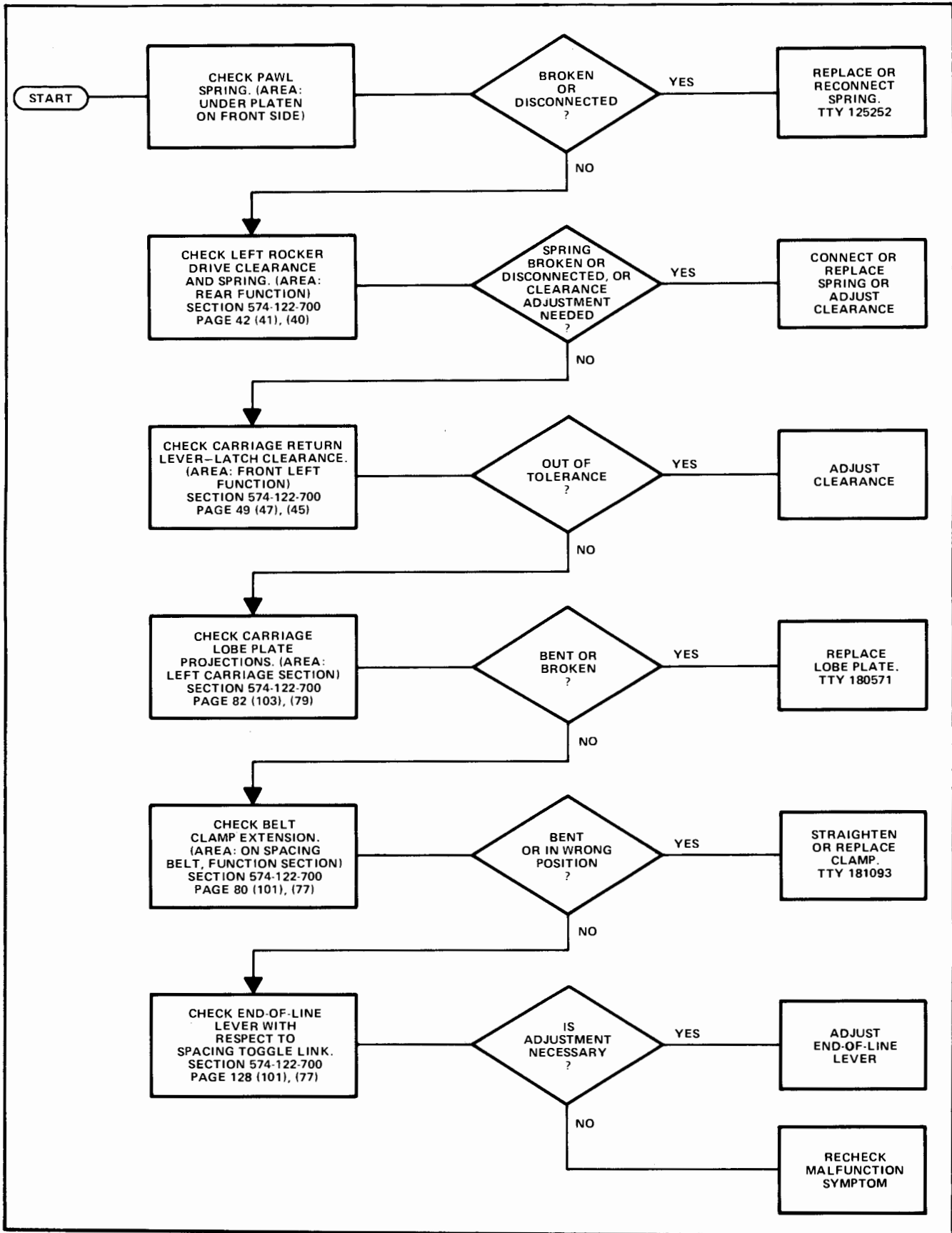

2089-7

Figure 5-5. Troubleshooting Flowchart, No Carriage Return

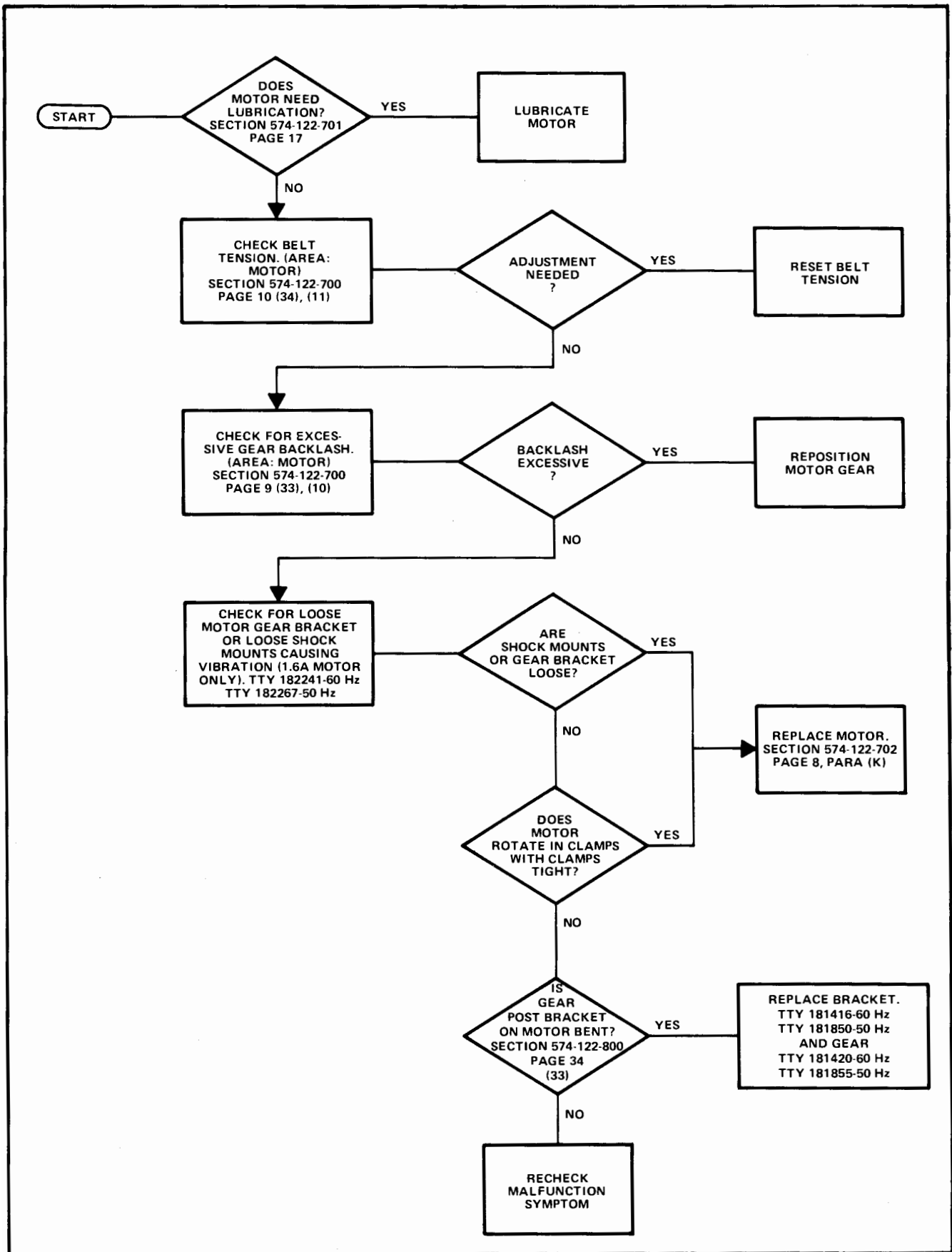

2089-8

Figure 5-6. Troubleshooting Flowchart, Noisy Motor

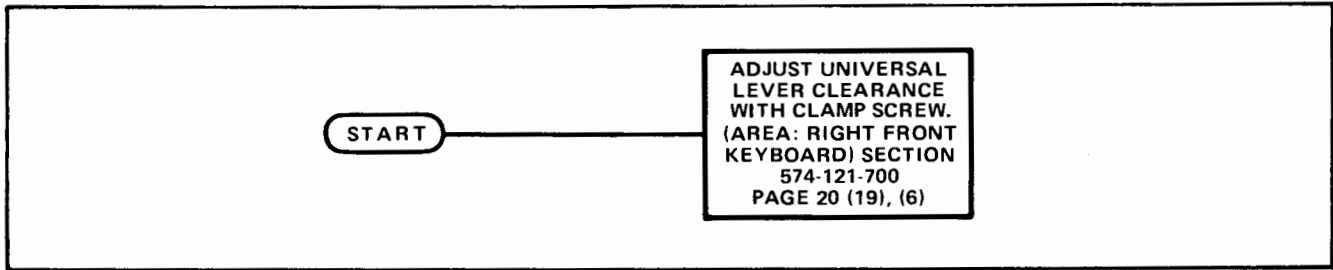

2089-3

Figure 5-7. Troubleshooting Flowchart, Double Printing

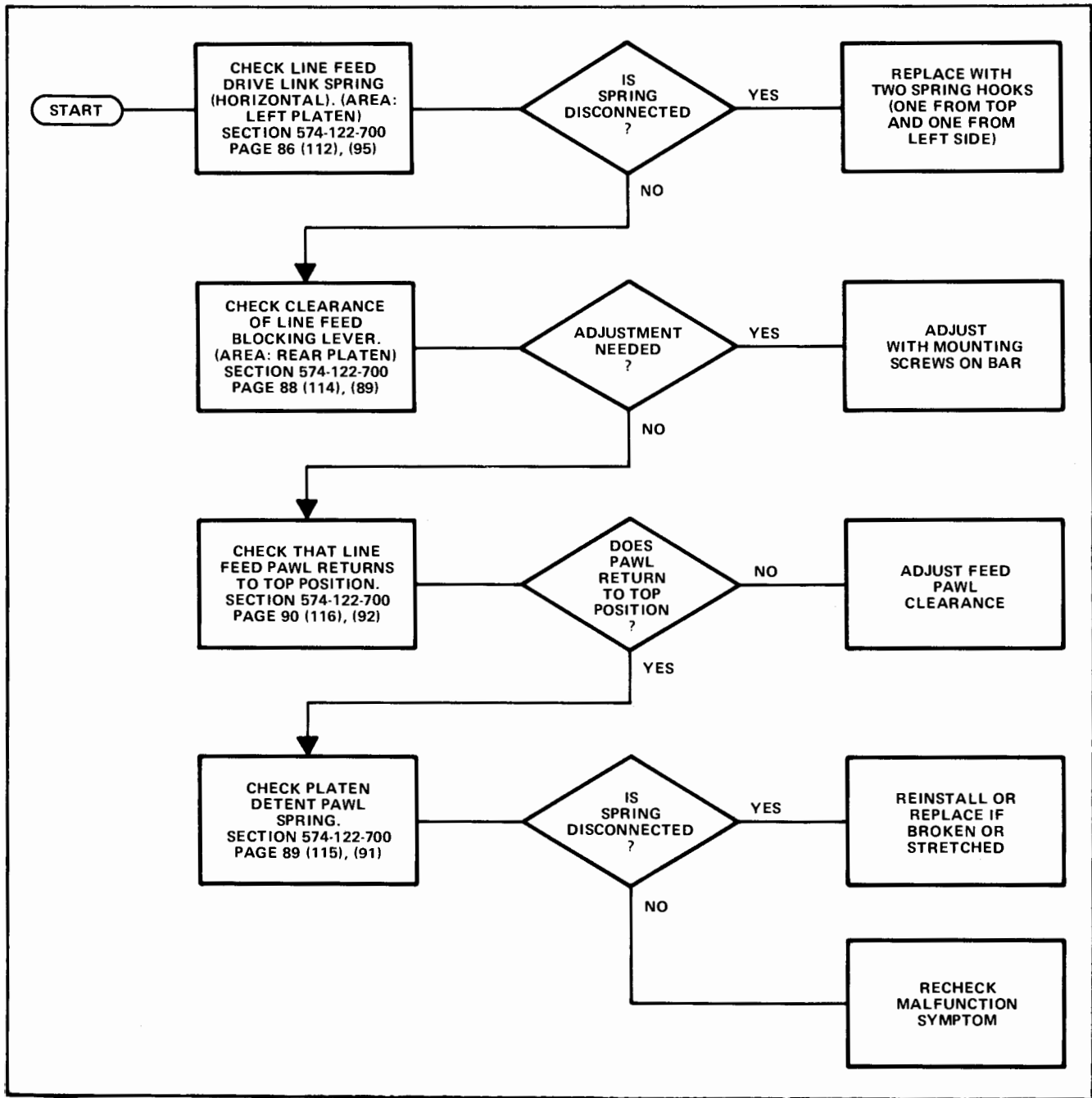

2089-9

Figure 5-8. Troubleshooting Flowchart, No Line Feed

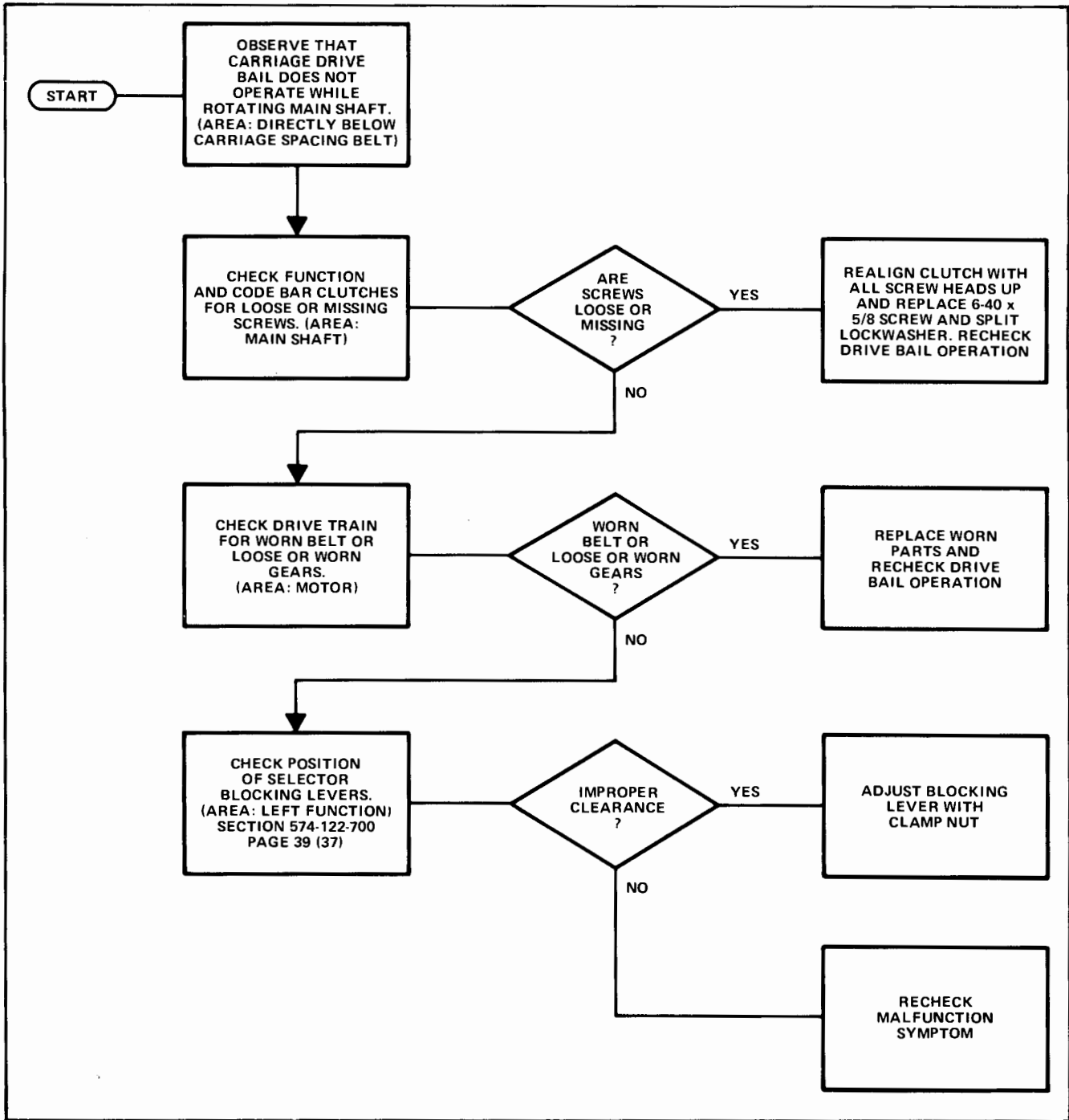

2089-10

Figure 5-9. Troubleshooting Flowchart, Cannot Print or Punch from Keyboard

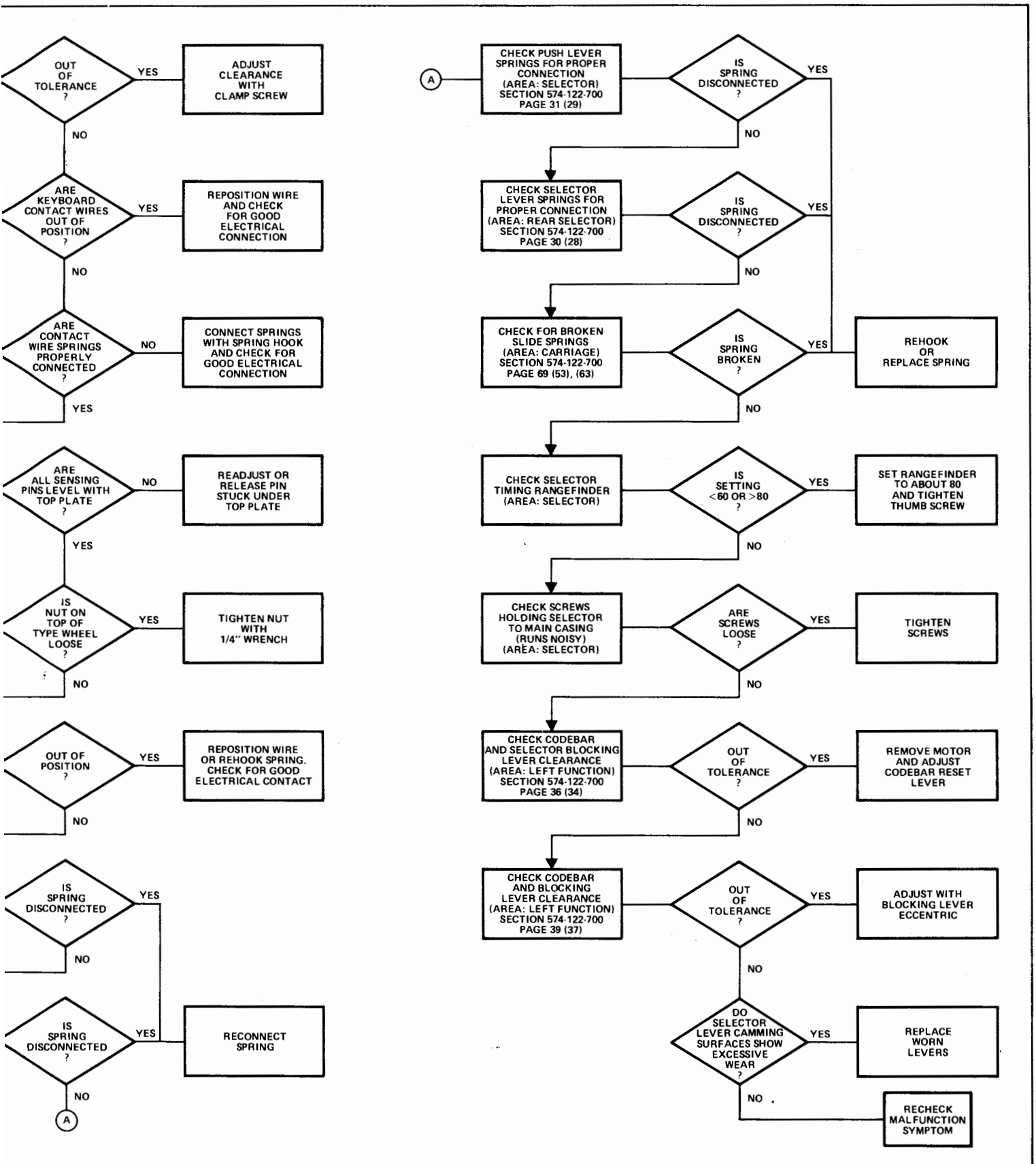
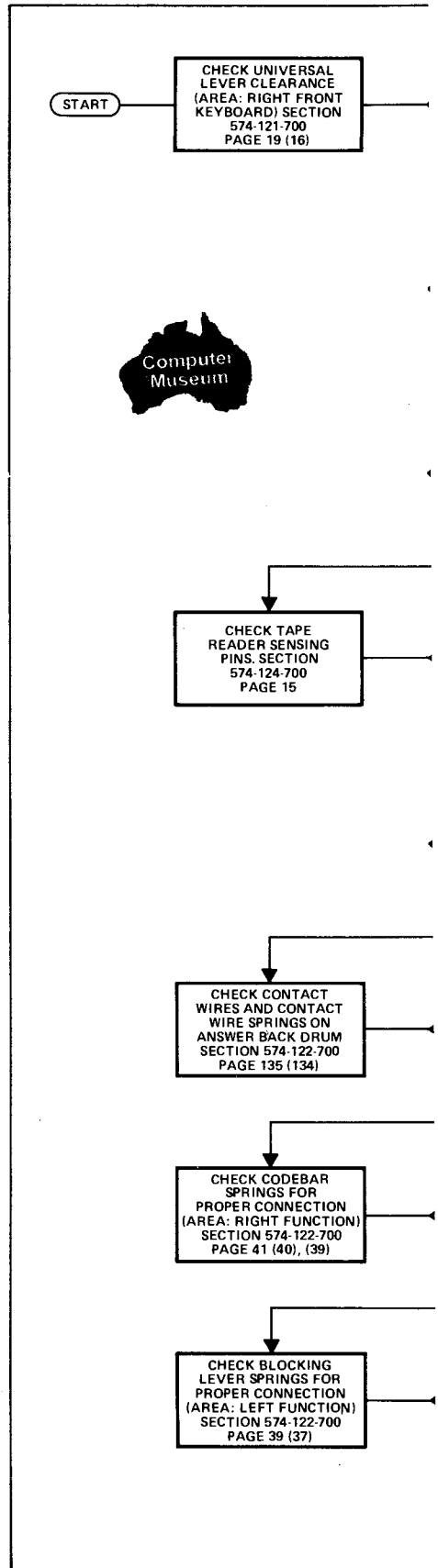
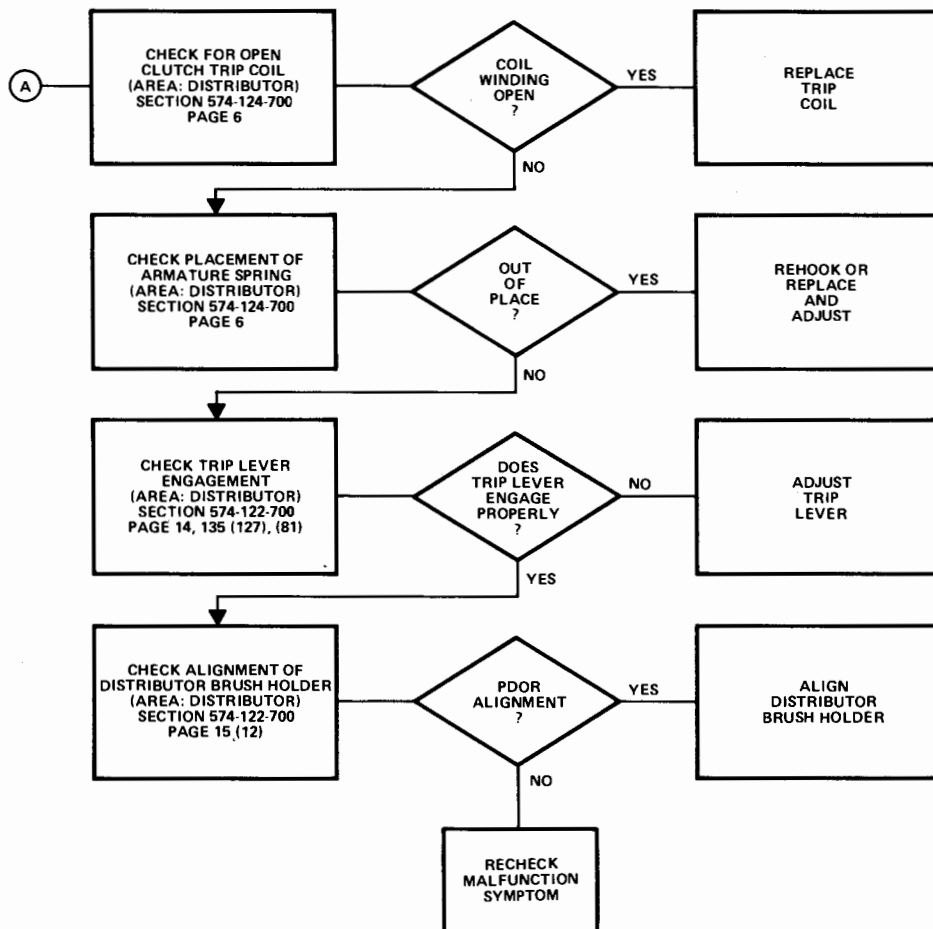

Figure 5-10. Troubleshooting Flowchart, Prints Improper Symbols





ES

REWIRE MAGNET

ES

REPLACE PLUG IN RECEPTACLE

CHECK FOR BAD POWER SUPPLY TRANSISTOR (Q1 AND Q2 ON METAL BRACKET)

ADJUST DISTRIBUTOR TRIP LINKAGE



Figure 5-11. Troubleshooting Flowchart, Runs Open (LOCAL Position) with Selector Open

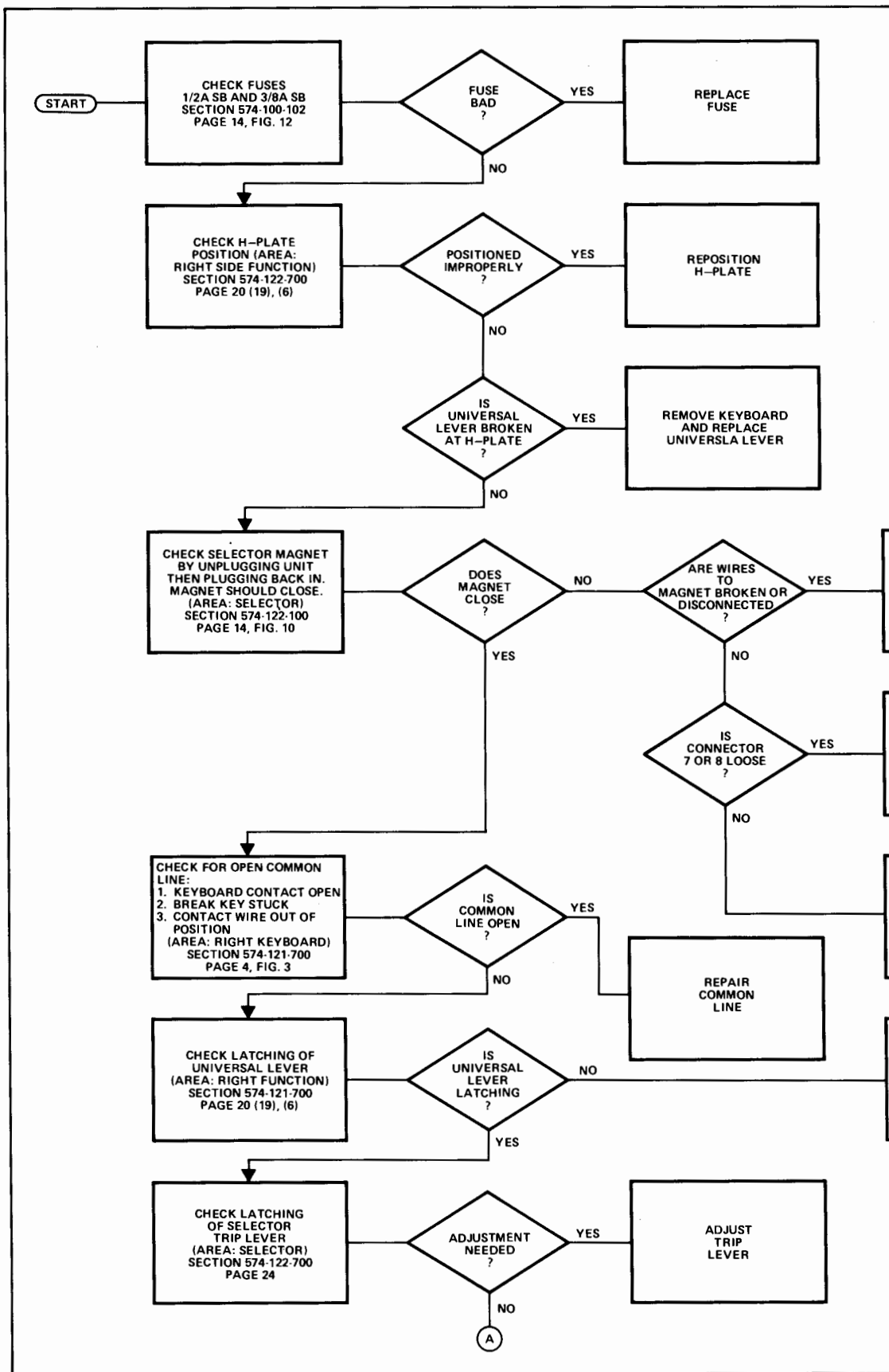

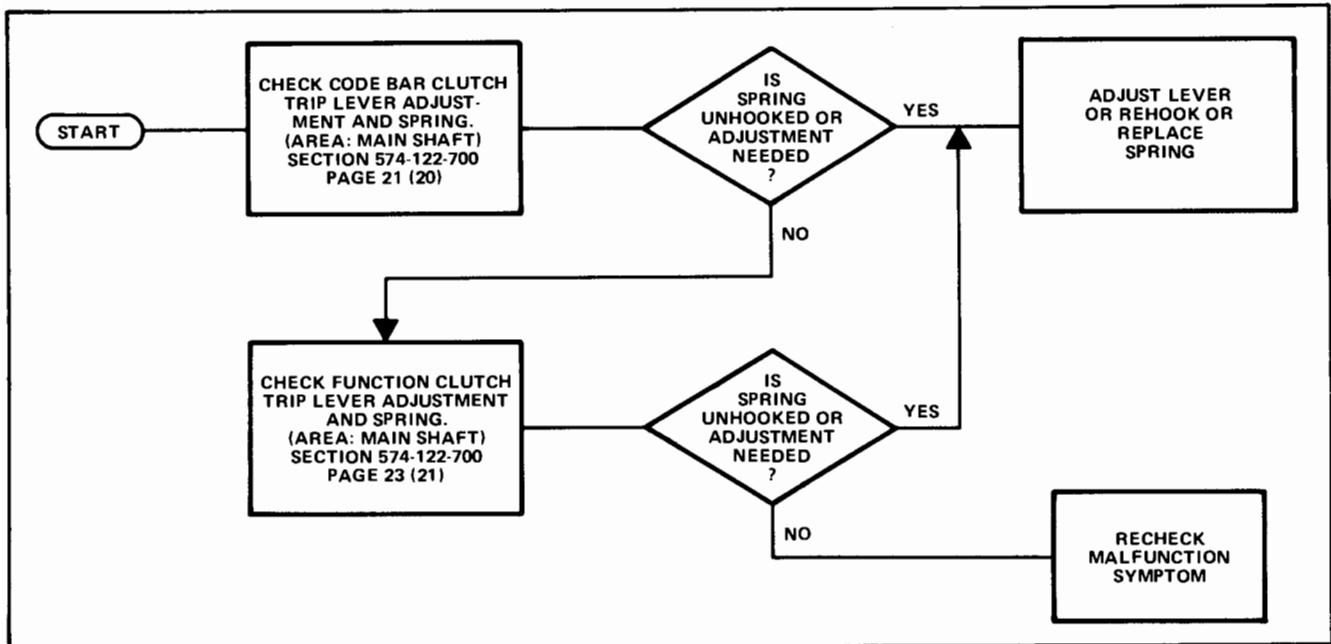

2089-16

Figure 5-12. Troubleshooting Flowchart, Runs Open (LOCAL Position) with Selector Closed

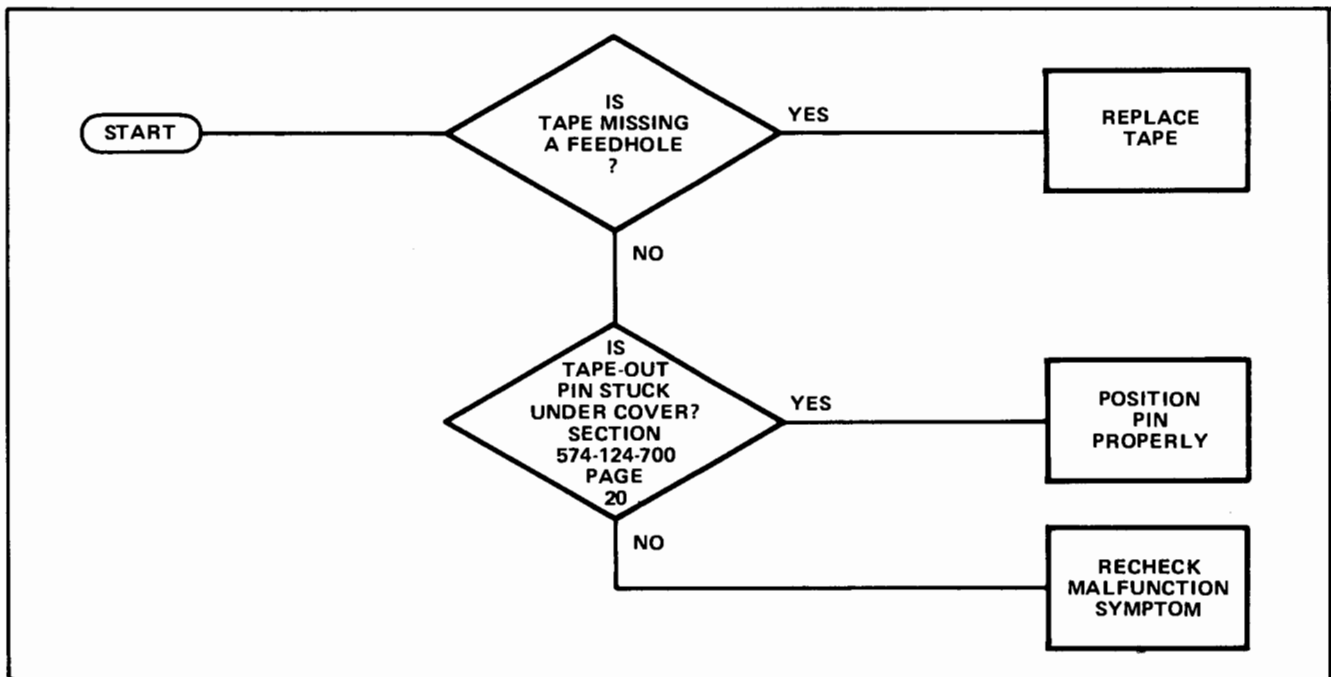

2089-17

Figure 5-13. Troubleshooting Flowchart, Runs Open (LOCAL Position) with Reader On

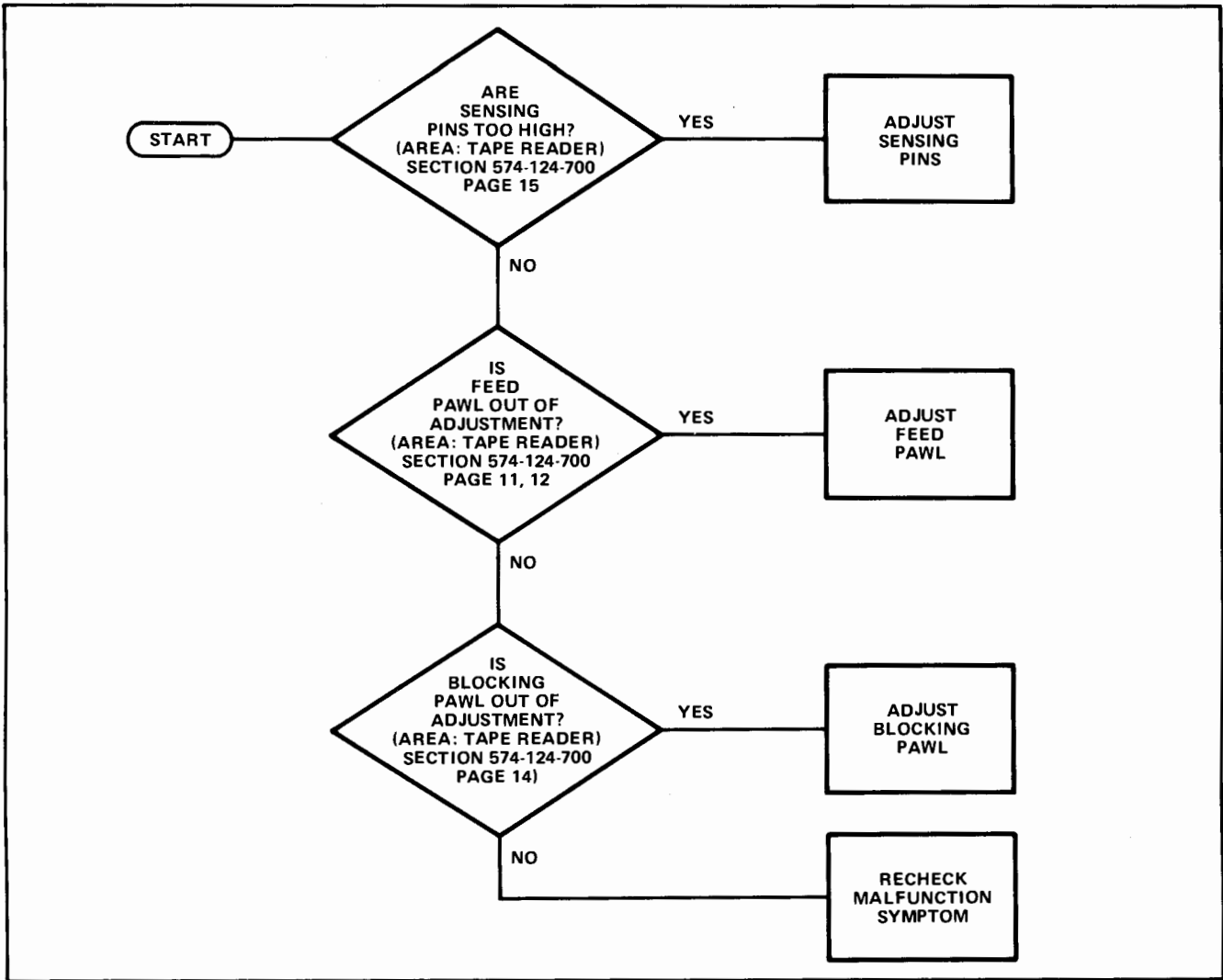

2089-19

Figure 5-14. Tape Reader Advances Tape Incorrectly

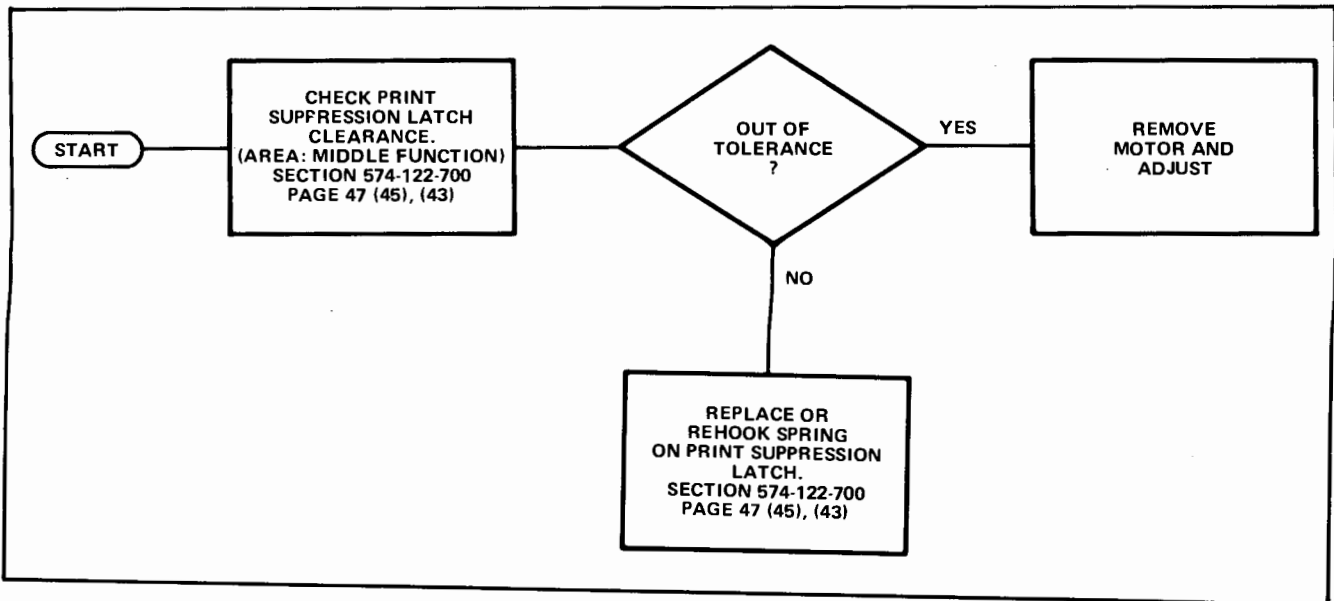

2089-13

Figure 5-15. Troubleshooting Flowchart, Prints when Function Is Selected

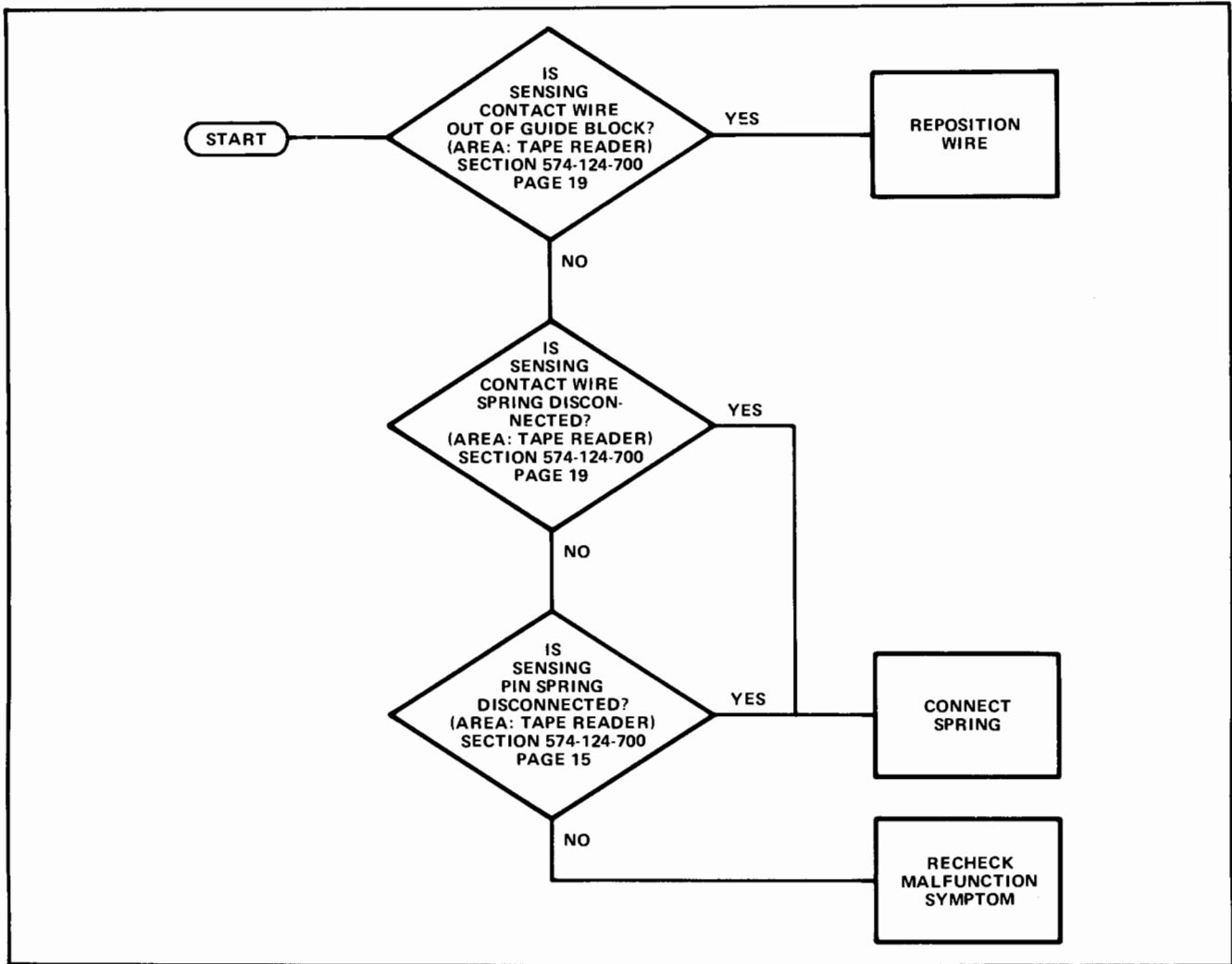

2089-18

Figure 5-16. Troubleshooting Flowchart, Tape Reader Reading Improperly

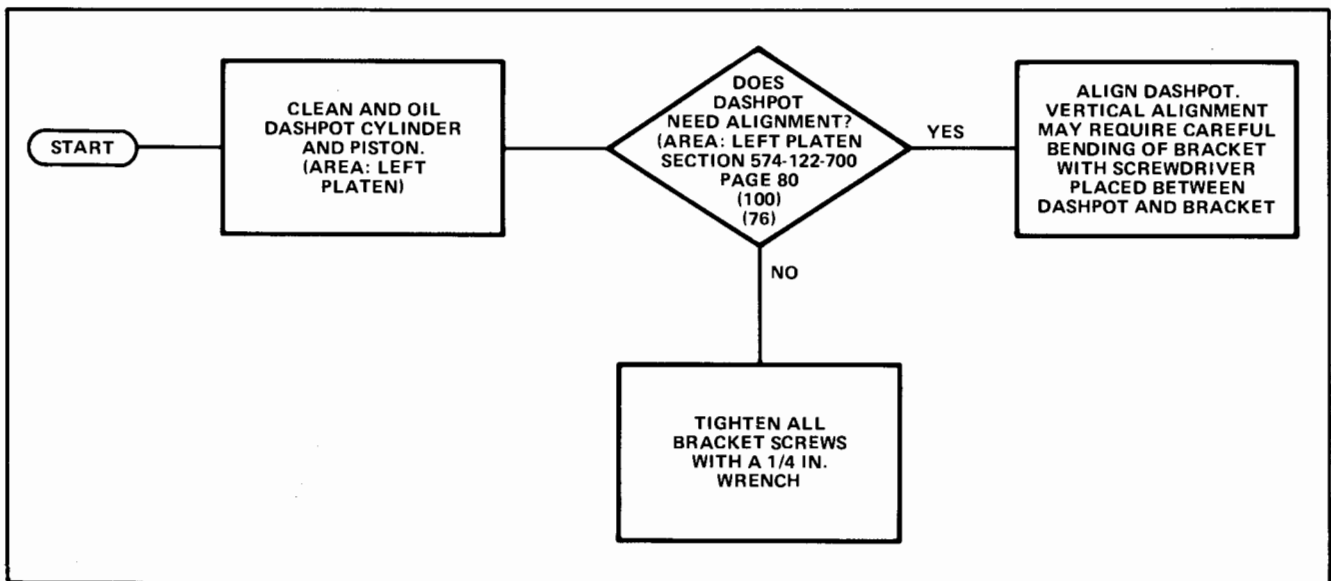

2089-12

Figure 5-17. Troubleshooting Flowchart, No Spacing at Left Margin

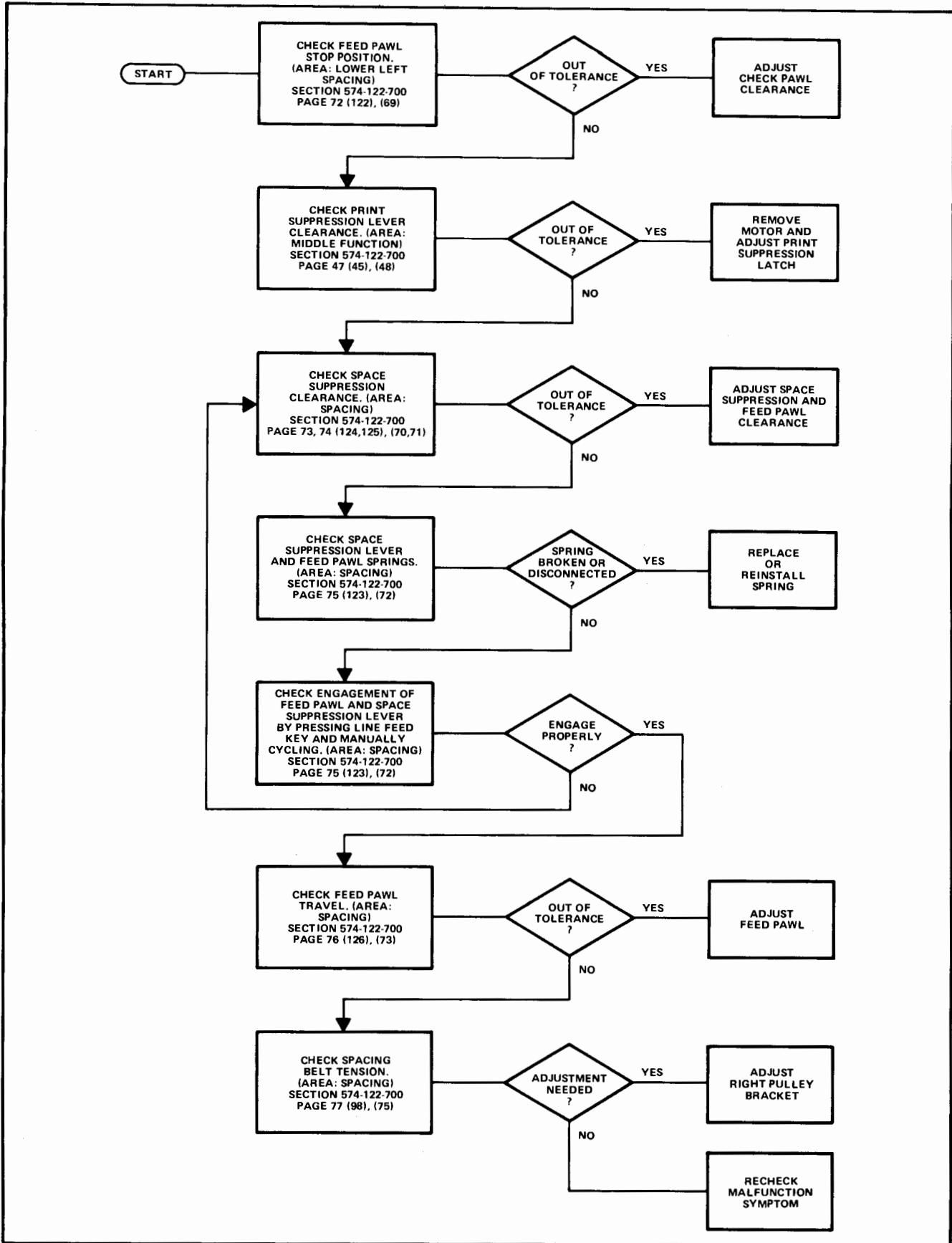

2089-11

Figure 5-18. Troubleshooting Flowchart, No Spacing

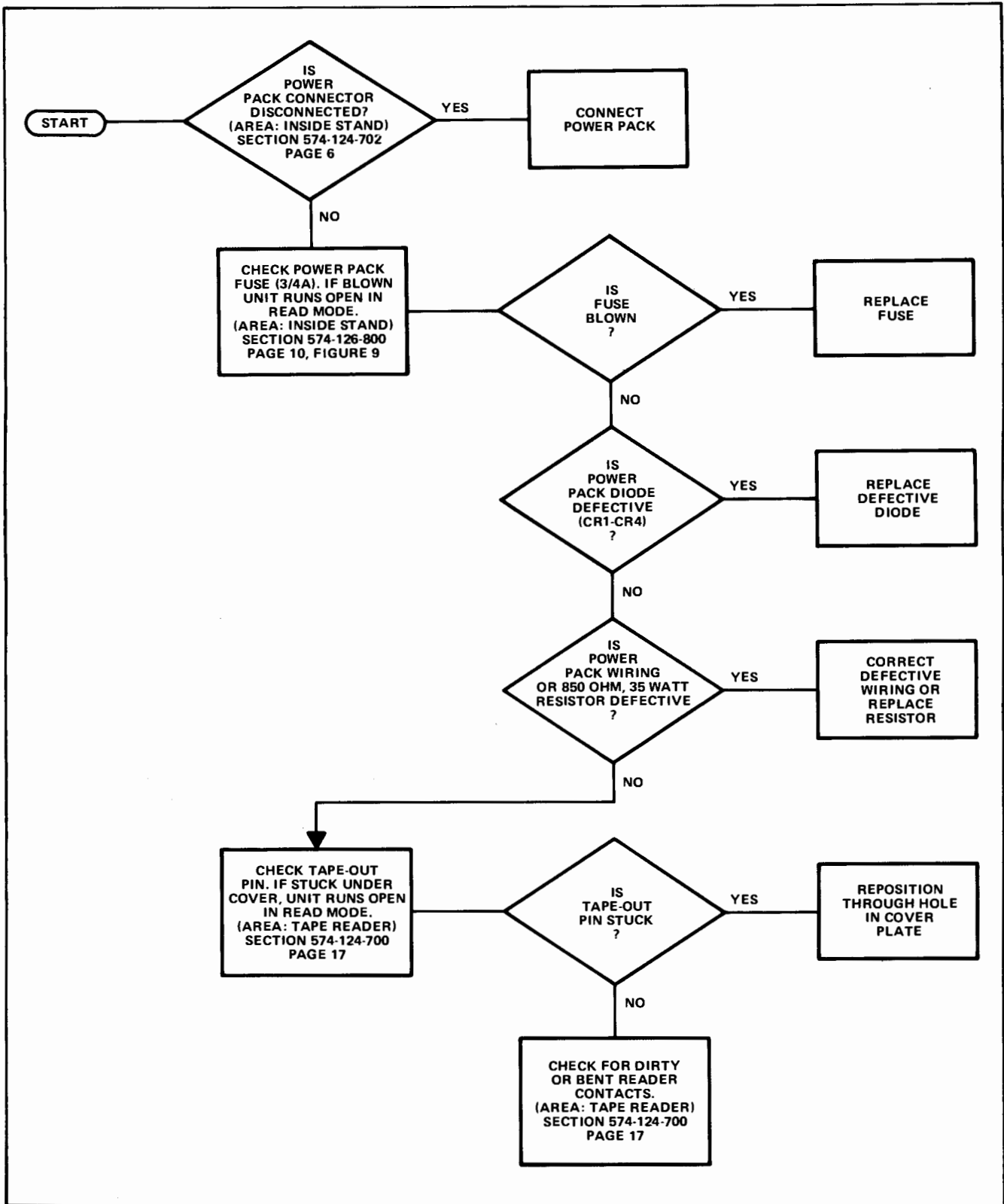

2089-20

Figure 5-19. Troubleshooting Flowchart, Tape Reader Will Not Read

Table 5-3. Reader Control Card Replaceable Parts

REFERENCE DESIGNATION	HP PART NO.	DESCRIPTION	MFR CODE	MFR PART NO.
	02752-6001	Reader Control Assembly	28480	02752-6001
CR1	1901-0026	Diode, Si, 0.75A, 200 PIV	04713	SR1358-8
CR2	1901-0081	Diode, Si, 50 WV	07263	FD1415
Q1	1854-0094	Transistor, Si, NPN	07263	2N3646
Q2	1854-0063	Transistor, Si, NPN	04713	2N3055
R1	0686-1025	Resistor, Fxd, Comp, 1k, 5%, 1/2w	01121	EB1025
R2	0686-2025	Resistor, Fxd, Comp, 2k, 5%, 1/2w	01121	EB2025
R3	0686-1035	Resistor, Fxd, Comp, 10k, 5%, 1/2w	01121	EB1035
R4	0686-4715	Resistor, Fxd, Comp, 470 ohms, 5%, 1/2w	01121	EB4715
R5	0686-2715	Resistor, Fxd, Comp, 270 ohms, 5%, 1/2w	01121	EB2715
R6	0686-1525	Resistor, Fxd, Comp, 1500 ohms, 5%, 1/2w	01121	EB1525

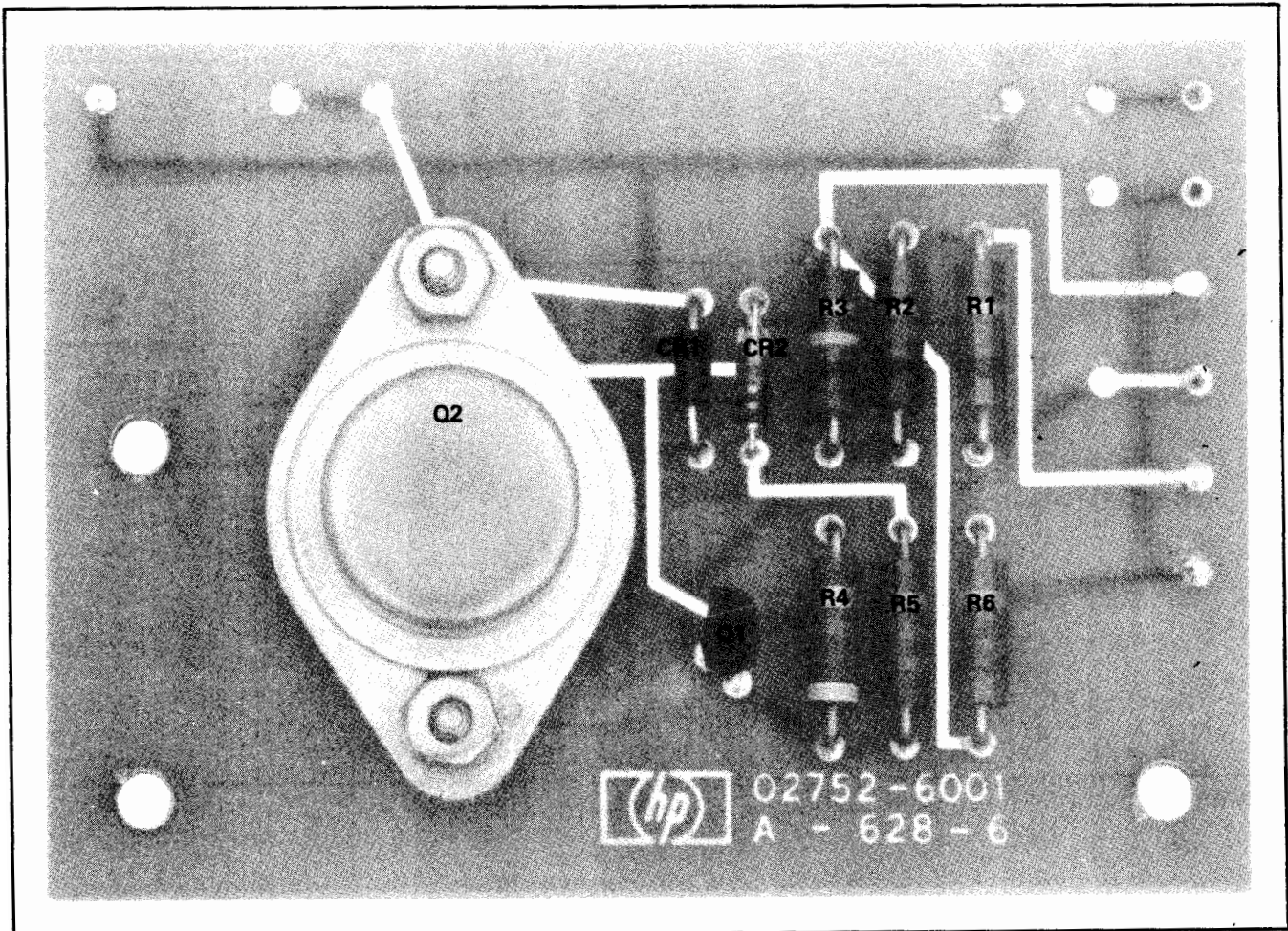

2089-22

Figure 5-20. Reader Control Card, Parts Location Diagram

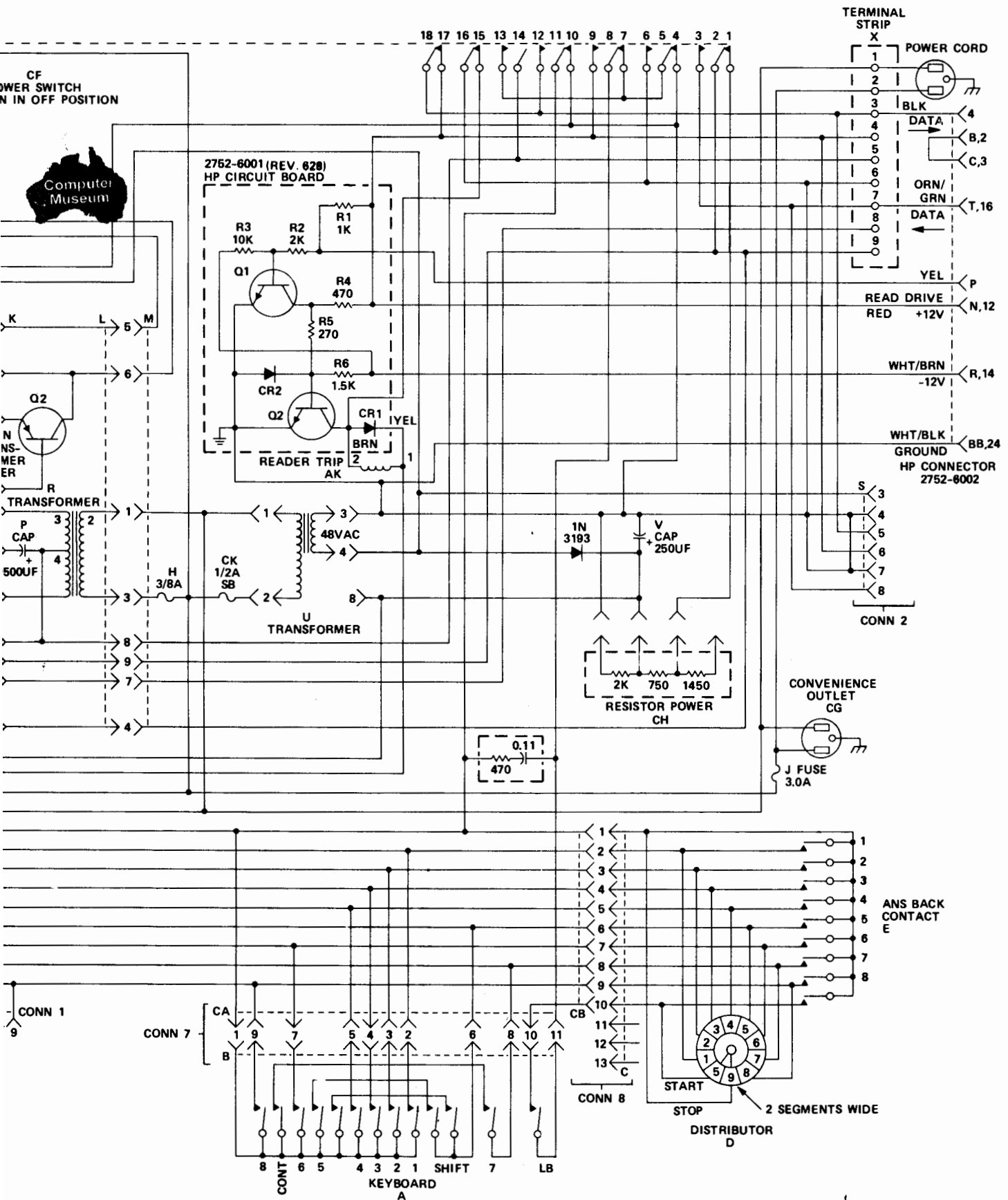
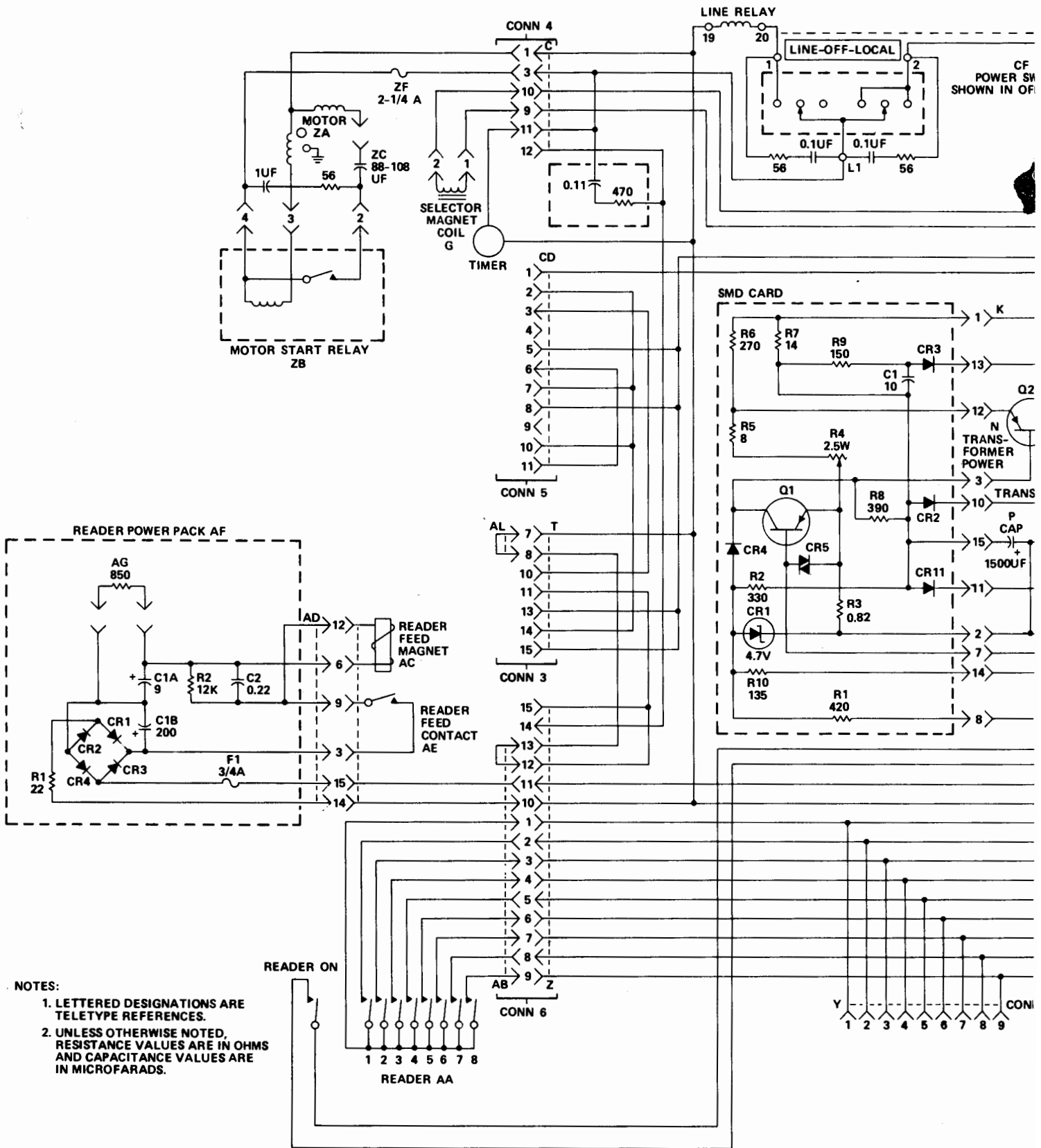

Figure 5-21. Teleprinter Schematic Diagram



NOTES:

1. LETTERED DESIGNATIONS ARE TELETYPE REFERENCES.
2. UNLESS OTHERWISE NOTED, RESISTANCE VALUES ARE IN OHMS AND CAPACITANCE VALUES ARE IN MICROFARADS.

SECTION VI

REPLACEABLE PARTS

6-1. INTRODUCTION.

6-2. This section provides a replaceable parts cross reference between Teletype Corporation part numbers and Hewlett-Packard part numbers. Only parts with high usage rates have been assigned Hewlett-Packard part numbers; the cross reference (table 6-1) includes all parts currently in this category. Table 6-2 provides a list of reference designations and abbreviations encountered in this manual, and table 6-3 provides a manufacturers code list.

6-3. ORDERING INFORMATION.

6-4. All parts that have been assigned an HP part number may be ordered from the local Hewlett-Packard Sales and Service Office (addresses are given at the back of

this manual). Teletype Corporation, Skokie, Illinois can supply all other parts.

6-5. When ordering parts from Hewlett-Packard, be sure to specify the following information for each part ordered:

- a. Unit model number.
- b. Unit serial number.
- c. Hewlett-Packard stock number for each part.
- d. Description of each part as listed in the Teletype Corporation manual supplied with the unit.
- e. Circuit reference designation (if applicable).

Table 6-1. Replaceable Parts Cross Reference

DESCRIPTION	TELETYPE PART NO.	HP PART NO.
Spring, Cover	74709	1530-1531
Spring, Expansion	76422	1460-1196
Spring, Expansion	90615	1460-1194
Spring, Expansion	121100	1460-1195
Shoe, Secondary Clutch	150043	1530-1018
Shoe, Primary Clutch	150044	1530-1019
Spring	150241	1530-1020
Oiler Felt, Function Bail	150930	1530-1533
Spring, Expansion	151397	1460-1197
Spring, Clutch	151728	1530-1535
Cover, Keyboard	180027	1530-1431
Spring, Multi-Tined	180034	1460-1192
Head, Print Hammer	180502	1530-1010
Spring	180555	1530-1529
Plate, Carriage Return Trip	180571	1530-1534
Lever, Shoe Release	180646	1530-1016
Knob, Range Adjust	180654	1530-1015
Brush, Carbon	180979	1530-1013
Disc, Distributor	180987	1530-1014
Bearing, Main Shaft	181001	1530-1433
Bearing, Main Shaft	181002	1530-1434
Shaft, Main Shaft	181007	1530-1435
Knob, Platen	181039	1530-1003
Holder, Paper	181043	1530-1437
Lid (w/window)	181132	4040-0795
Fan, Blower, 60 Hz	181151	1530-1011
Indicator, Elapsed Time, 60 Hz	181265	1120-1534
Indicator, Elapsed Time, 50 Hz	—	1530-1289
Spring	181284	1530-1017
Capacitor, Motor Start	181384	1130-0811
Belt, Drive	181409	1530-1012
Gear, Pinion	181411	1530-1009
Plate, Motor Gear	181416	1530-1008
Pulley, 100 WPM, 60 Hz	181420	1530-1007
Knob, Line/Local Switch	181824	1530-1002
Plate, Mounting, 50 Hz	181850	1530-1213
Gear, 17 Tooth, 50 Hz	181851	1530-1214
Pulley, 100 WPM, 50 Hz	181855	1530-1215
Motor, Drive, 60 Hz	181870	1530-0996
Transformer, 50 Hz	181878	1530-1216
Transformer, 50 Hz	181879	1530-1217
Transformer (Opt 001), stepdown, 230:115V, 50 Hz	—	9100-0598
Fan, Blower, 50 Hz	182181	1530-1218

Table 6-1. Replaceable Parts Cross Reference (Continued)

DESCRIPTION	TELETYPE PART NO.	HP PART NO.
Deflector, Fan (50 Hz units)	182183	1530-1219
Motor, Drive, 50 Hz	182267	1530-1212
Lid, Punch Unit	182912	4040-0796
Holder, Paper Tape	182918	1530-1436
Cover, Left, Punch	182922	4040-0794
Latch, Spring	183029	1530-1005
Lid, Reader Unit	183032	1530-1530
Bail, Tight Tape	183033	1530-1004
Cover, Contact	183062	1535-0029
Wheel, Feed	183071	1530-1006
Scr., Fil. Hd., 4-40 x 9/64	183112	2200-0764
Cover, Tape Reader	183135	4040-0827
Guide, Line	183254	1535-0030
Scr., Self-Tapping, No. 8	183261	0624-0274
Scr., Thumb, 8-32	184085	0570-1123
Drum, Answer Back	184149	1530-1532
Scr., Self-Tapping, 1/4 - 14	192289	0624-0273
Reader (w/Harness)	UX800	1535-0036
Fuse, 2A, Slo Blo	—	2110-0303
Fuse, 3A, Slo Blo	—	2110-0381
Fuse, 3/8A, Slo Blo	—	2110-0044
Fuse, 1/2A, Slo Blo	—	2110-0008
Fuse, 1.8A, Slo Blo	—	2110-0353
Kit, Overhaul	—	5080-5376
Includes all parts in 3000 hr maintenance kit and the following parts		
Bearing, Ball (2)	180467	
Bearing, Ball (4)	180468	
Bearing, Ball (1)	180575	
Bearing, Ball (1)	180576	
Lever, Blocking (4)	180643	
Lever, Blocking (4)	180644	
Lever, Selector (8)	180645	
Lever, Lock (1)	180669	
Lever, Start W/Stud (1)	180671	
Armature Assembly (1)	180704	
Bearing (1)	180969	
Bearing (1)	180970	
Disc, Distributor (1)	180987	1530-1014
Bearing (1)	181001	1530-1433
Bearing (1)	181002	1530-1434
Plate W/Stud (1)	181416	1530-1008
Pulley & Gear W/insert, 100 WPM (1)	181420	1530-1007

Table 6-1. Replaceable Parts Cross Reference (Continued)

DESCRIPTION	TELETYPE PART NO.	HP PART NO.
Kit, 3000 hr maintenance	—	5080-5377
Includes following parts:		
Rail, Carriage (1)	185799	
Block, Rotary Drive (2)	180471	
Guide, Nylon (6)	180478	
Head, Print Hammer (1)	180502	1530-1010
Plate, W/Post (1)	180505	
Plate, W/Post (1)	180506	
Slide (Common) (1)	180510	
Slide (2)	180511	
Slide W/Plates (1)	180512	
Plate (1)	180518	
Rack (2)	180519	
Bail, Carriage Drive (1)	180544	
Bracket (1)	180549	
Shaft (2)	180920	
Bar, Code — (PS)	180947	
Brush, Carbon (2)	180979	1530-1013
Pawl, Feed (1)	181067	
Ratchet, Left W/Pin (1)	181125	
Ratchet, Right W/Pin (1)	181126	
Belt, Timing (1)	181409	1530-1012
Bar, Code & Blocking Lever (8-1) (1)	186282	
Bar, Code & Blocking Lever (8-2) (1)	186283	
Bar, Code & Blocking Lever (8-3) (1)	186284	
Bar, Code & Blocking Lever (8-4) (1)	186285	
Bar, Code & Blocking Lever (8-5) (1)	186286	
Bar, Code & Blocking Lever (8-6) (1)	186287	
Bar, Code & Blocking Lever (8-7) (1)	186288	
Bar, Code & Blocking Lever (8-8) (1)	186289	
Blocking Lever (4)	180643	
Blocking Lever (4)	180644	
Kit, Lubrication	—	5080-6610
Includes following:		
Accessory brush	—	9300-0082
No. 2 Brush	—	8520-0005 or 8520-0015
Applicator	—	8710-0001
Polyethylene bag (4 x 2 x 4)	—	9220-0006
Polyethylene bag (6 x 3 x 12)	—	9220-0001
Moly lube	—	6040-0012
Grease	KS7471	6040-0074

Table 6-1. Replaceable Parts Cross Reference (Continued)

DESCRIPTION	TELETYPE PART NO.	HP PART NO.
Teletype oil kit	—	5080-6614
Oil	KS7470	6040-0075
Bottle with dropper	—	1540-0084
Bottle cap	—	9300-0343
Cardboard box	—	9211-0022
Label	—	7120-1947
Maintenance Tools:		
Hook, Spring Pull	75765	1530-1438
Hook, Spring Pull	142554	1530-1439
Hook, Spring Push	142555	1530-1440
Tweezers	151392	1530-1441
Gauge Set	117781	1530-1442
Gauge Case for above	117375	1530-1443
Gauge Holder for below	93814	1530-1444
Gauge Set	93809	1530-1445
Gauge Set	179411	1530-1446
Handwheel	161430	1530-1447
w/screw	94540	
Handwheel Adapter	181465	1530-1448
w/screw	94540	
Bender, Spring	110445	1530-1449
Gauge, Tape	95960	1530-1450
Wrench, Open End 1/4 in.	125777	1530-1451
Tool, Typewheel Adj	180588	1530-1453

Table 6-2. Reference Designations and Abbreviations

REFERENCE DESIGNATIONS		
A = assembly	K = relay	TB = terminal board
B = motor	L = inductor	TP = test point
BT = battery	M = meter	U = integrated circuit
C = capacitor	MC = microcircuit	V = vacuum tube, neon bulb, photocell, etc.
CR = diode	P = plug connector	VR = voltage regulator
DL = delay line	Q = transistor	W = cable, jumper
DS = indicator (lamp)	R = resistor	X = socket
E = misc hardware	RT = thermistor	Y = crystal
F = fuse	S = switch	Z = tuned cavity, network
FL = filter	T = transformer	
J = receptacle connector		
ABBREVIATIONS		
A = amperes	gnd = ground(ed)	ph = Phillips head
ac = alternating current	gra = gray	pk = peak
ad = anode	grn = green	p-p = peak-to-peak
Al = aluminum	H = henries	pt = point
AR = as required	Hg = mercury	PIV = peak inverse voltage
adj = adjust	hr = hour(s)	PNP = positive-negative-positive
Assy = assembly	Hz = hertz	PWV = peak working voltage
B = base	hdw = hardware	porc = porcelain
bp = bandpass	hex = hexagon, hexagonal	posn = position(s)
bfo = beat frequency oscillator	ID = inside diameter	pozi = pozidrive
blk = black	IF = intermediate frequency	ph brz = phosphor bronze
blu = blue	in. = inch, inches	rf = radio frequency
brn = brown	I/O = input/output	rdh = round head
brs = brass	int = internal	rmo = rack mount only
Btu = British thermal unit	incl = include(s)	rms = root-mean-square
bwc = backward wave oscillator	insul = insulation, insulated	RWV = reverse working voltage
Be Cu = beryllium copper	impgrg = impregnated	rect = rectifier
C = collector	incand = incandescent	r/min = revolutions per minute
cw = clockwise	k = kilo (10^3), kilohm	s = second
ccw = counterclockwise	lp = low pass	SB = slow-blow
cer = ceramic	m = milli (10^{-3})	Se = selenium
cmo = cabinet mount only	M = mega (10^6), megohm	Si = silicon
com = common	Myr = Mylar	scr = silicon-controlled rectifier
crt = cathode-ray tube	mfr = manufacturer	sil = silver
CTL = capacitor-transistor logic	mom = momentary	sst = stainless steel
cath = cathode	mtg = mounting	stl = steel
cd pl = cadmium plate	misc = miscellaneous	spcl = special
Comp = composition	met ox = metal oxide	spdt = single-pole, double-throw
conn = connector	mintr = miniature	spst = single-pole, single-throw
compl = complete	n = nano (10^{-9})	semicond = semiconductor
dc = direct current	nc = normally closed or no connection	Ta = tantalum
dr = drive	Ne = neon	td = time delay
DTL = diode-transistor logic	no. = number or normally open	Ti = titanium
depc = deposited carbon	np = nickel plated	tgl = toggle
dpdt = double-pole, double-throw	NPN = negative-positive-negative	thd = thread
dpst = double-pole, single-throw	NPO = negative positive zero (zero temperature coefficient)	tol = tolerance
E = emitter	NSR = not separately replaceable	TTL = transistor-transistor logic
ext = external	NRFR = not recommended for field replacement	term = terminal
encap = encapsulated	OD = outside diameter	U (μ) = micro (10^{-6})
elctlt = electrolytic	OBD = order by description	V = volt(s)
F = farads	orn = orange	var = variable
FF = flip-flop	ovh = oval head	vio = violet
flh = flat head	oxd = oxide	VDCW = direct current working volts
flm = film	p = pico (10^{-12})	W = watts
fxd = fixed	PC = printed circuit	ww = wirewound
filh = fillister head		wht = white
G = giga (10^9)		WIV = working inverse voltage
Ge = germanium		yel = yellow
gl = glass		

Table 6-3. Code List of Manufacturers

The following code numbers are from the Federal Supply Code for Manufacturers Cataloging Handbooks H4-1 (Name to Code) and H4-2 (Code to Name) and their latest supplements. The date of revision and the date of the supplements used appear at the bottom of each page. Alphabetical codes have been arbitrarily assigned to suppliers not appearing in the H4 Handbooks.

Code No.	Manufacturer	Address	Code No.	Manufacturer	Address	Code No.	Manufacturer	Address
00000	U. S. A Common	Any supplier of U.S.	05347	Ultronix, Inc.	San Mateo, Cal.	11236	CTS of Berne, Inc.	Berne, Ind.
00136	McCoy Electronics	Mount Holly Springs, Pa.	05397	Union Carbine Corp., Elect.		11237	Chicago Telephone of California, Inc.	So. Pasadena, Cal.
00213	Sage Electronics Corp.	Rochester, N. Y.		Div.	New York, N. Y.		Bay State Electronics Corp.	Waltham, Mass.
00287	Cemco, Inc.	Danielson, Conn.	05574	Viking Ind. Inc.	Canoga Park, Cal.	11242	Teledyne Inc., Microwave Div.	Palo Alto, Cal.
00334	Humidial	Colton, Calif.	05593	Icore Electro-Plastics Inc.	Sunnyvale, Cal.	11312	National Seal	Downey, Cal.
00348	Mictron, Co., Inc.	Valley Stream, N. Y.	05616	Cosmo Plastic (c/o Electrical Spec. Co.)	Cleveland, Ohio	11314	Precision Connector Corp.	Jamaica, N. Y.
00373	Garlock Inc.	Cherry Hill, N. J.	05624	Barber Colman Co.	Rockford, Ill.	11534	Duncan Electronics Inc.	Costa Mesa, Cal.
00656	Aerovox Corp.	New Bedford, Mass.	05728	Tiffen Optical Co.	Roslyn Heights, Long Island, N. Y.	11711	General Instrument Corp.	
00779	Amp. Inc.	Harrisburg, Pa.	05729	Metro-Tel Corp.	Westbury, N. Y.		Semiconductor Division Products Group	Newark, N. J.
00781	Aircraft Radio Corp.	Boonton, N. J.	05783	Stewart Engineering Co.	Santa Cruz, Cal.	11717	Imperial Electronic, Inc.	Buena Park, Cal.
00809	Croven, Ltd.	Whitby, Ontario, Canada	05820	Wakefield Engineering Inc.	Wakefield, Mass.	11870	Melabs, Inc.	Palo Alto, Cal.
00815	Northern Engineering Laboratories, Inc.	Burlington, Wis.	06004	Bassick Co., Div. of Stewart Warner Corp.	Bridgeport, Conn.	12136	Philadelphia Handle Co.	Camden, N. J.
00853	Sangamo Electric Co., Pickens Div.	Pickens, S. C.	06090	Raychem Corp.	Redwood City, Cal.	12361	Grove Mfg. Co., Inc.	Shady Grove, Pa.
00866	Goe Engineering Co.	City of Industry, Cal.	06175	Bausch and Lomb Optical Co.	Rochester, N. Y.	12574	Gulton Ind. Inc., Data System Div.	Albuquerque, N. M.
00891	Carl E. Holmes Corp.	Los Angeles, Cal.	06402	E. T. A. Products Co. of America	Chicago, Ill.	12697	Clarostat Mfg. Co.	Dover, N. H.
00929	Microlab Inc.	Livingston, N. J.	06540	Amatom Electronic Hardware Co., Inc.	New Rochelle, N. Y.	12728	Elmar Corp.	W. Haven, Conn.
01002	General Electric Co., Capacitor Dept.	Hudson Falls, N. Y.	06555	Beede Electrical Instrument Co., Inc.	Penacook, N. H.	12859	Nippon Electric Co., Ltd.	Tokyo, Japan
01009	Alden Products Co.	Brockton, Mass.	06666	General Devices Co., Inc.	Indianapolis, Ind.	12881	Metex Electronics Corp.	Clark, N. J.
01121	Allen Bradley Co.	Milwaukee, Wis.	06751	Components Inc., Ariz. Div.	Phoenix, Arizona	12930	Delta Semiconductor Inc.	Newport Beach, Cal.
01255	Litton Industries, Inc.	Beverly Hills, Cal.	06812	Torrington Mfg. Co., West Div.	Van Nuys, Cal.	12954	Dickson Electronics Corp.	Scottsdale, Arizona
01281	TRW Semiconductors, Inc.	Lawndale, Cal.	06980	Varian Assoc. Etmac Div.	San Carlos, Cal.	13019	Aircro Supply Co., Inc.	Wichita, Kansas
01295	Texas Instruments, Inc., Transistor Products Div.	Dallas, Texas	07088	Kelvin Electric Co.	Van Nuys, Cal.	13061	Wilco Products	Detroit, Mich.
01349	The Alliance Mfg. Co.	Alliance, Ohio	07126	Digitran Co.	Pasadena, Cal.	13103	Thermolloy	Dallas, Texas
01538	Small Parts Inc.	Los Angeles, Cal.	07137	Transistor Electronics Corp.	Minneapolis, Minn.	13327	Solitron Devices Inc.	Tappan, N. Y.
01589	Pacific Relays, Inc.	Van Nuys, Cal.	07138	Westinghouse Electric Corp., Electronic Tube Div.	Elmira, N. Y.	13396	Telefunken (GmbH)	Hanover, Germany
01670	Gudebrod Bros. Silk Co.	New York, N. Y.	07149	Filmohm Corp.	New York, N. Y.	13835	Midland-Wright Div. of Pacific Industries, Inc.	Kansas City, Kansas
01930	Amerock Corp.	Rockford, Ill.	07233	Cinch-Graphik Co.	City of Industry, Cal.	14099	Sem-Tech	Newbury Park, Cal.
01960	Pulse Engineering Co.	Santa Clara, Cal.	07256	Silicon Transistor Corp.	Carle Place, N. Y.	14193	Calif. Resistor Corp.	Santa Monica, Cal.
02114	Ferroxcube Corp. of America	Saugerties, N. Y.	07261	Avnet Corp.	Culver City, Cal.	14298	American Components, Inc.	Conshohocken, Pa.
02116	Wheelock Signals, Inc.	Long Branch, N. J.	07263	Fairchild Camera & Inst. Corp., Semiconductor Div.	Mountain View, Cal.	14433	ITT Semiconductor, a Div. of Int. Telephone and Telegraph Corporation	West Palm Beach, Fla.
02286	Cole Rubber and Plastics Inc.	Sunnyvale, Cal.	07322	Minnesota Rubber Co.	Minneapolis, Minn.	14493	Hewlett-Packard Company	Loveland, Colo.
02660	Amphenol-Borg Electronics Corp.	Broadview, Ill.	07387	Birtcher Corp., The	Monterey Park, Cal.	14655	Cornell Dublier Electric Corp.	Newark, N. J.
02735	Radio Corp. of America, Semiconductor and Materials Division	Somerville, N. J.	07397	Sylvania Elect. Prod. Inc., Mt. View Operations	Mountain View, Cal.	14674	Corning Glass Works	Corning, N. Y.
02771	Vocaline Co. of America, Inc.	Old Saybrook, Conn.	07700	Technical Wire Products Inc.	Cranford, N. J.	14752	Electro Cube Inc.	San Gabriel, Cal.
02777	Hopkins Engineering Co.	San Fernando, Cal.	07829	Bodine Elect. Co.	Chicago, Ill.	14960	Williams Mfg. Co.	San Jose, Cal.
02875	Hudson Tool & Die	Newark, N. J.	07910	Continental Device Corp.	Hawthorne, Cal.	15106	The Sphere Co., Inc.	Little Falls, N. J.
03296	Nylon Molding Corp.	Springfield, N. J.	07933	Raytheon Mfg. Co., Semiconductor Div.	Mountain View, Cal.	15203	Webster Electronics Co.	New York, N. Y.
03508	G. E. Semiconductor Prod. Dept.	Syracuse, N. Y.	07980	Hewlett-Packard Co., New Jersey Division	Rockaway, N. J.	15287	Scionics Corp.	Northridge, Cal.
03705	Apex Machine & Tool Co.	Dayton, Ohio	08145	U. S. Engineering Co.	Los Angeles, Cal.	15291	Adjustable Bushing Co.	N. Hollywood, Cal.
03797	Eldema Corp.	Compton, Calif.	08289	Blinn, Delbert Co.	Pomona, Cal.	15558	Micron Electronics, Garden City	Long Island, N. Y.
03818	Parker Seal Co.	Los Angeles, Cal.	08358	Burgess Battery Co.	Niagara Falls, Ontario, Canada	15566	Amprobe Inst. Corp.	Lynbrook, N. Y.
03877	Transitron Electric Corp.	Wakefield, Mass.	08524	Deutsch Fastener Corp.	Los Angeles, Cal.	15631	Cabletronics	Costa Mesa, Cal.
03888	Pyrofilm Resistor Co., Inc.	Cedar Knolls, N. J.	08664	Bristol Co., The	Waterbury, Conn.	15772	Twentieth Century Coil Spring Co.	Santa Clara, Cal.
03954	Singer Co., Diehl Div., FINDERNE Plant	Sumerville, N. J.	08717	Sloan Company	Sun Valley, Cal.	15801	Fenwal Elect. Inc.	Framingham, Mass.
04009	Arrow, Hart and Hegeman Elect. Co.	Hartford, Conn.	08718	ITT Cannon Electric Inc., Phoenix Div.	Phoenix, Arizona	15818	Amelco Inc.	Mountain View, Cal.
04013	Taruox Corp.	Lambertville, N. J.	08727	National Radio Lab. Inc.	Paramus, N. J.	16037	Spruce Pine Mica Co.	Spruce Pine, N. C.
04062	Arco Electronic Inc.	Great Neck, N. Y.	08792	CBS Electronics Semiconductor Operations, Div. of CBS Inc.	Lowell, Mass.	16179	Omni-Spectra Inc.	Detroit, Ill.
04217	Essex Wire	Los Angeles, Cal.	08806	General Electric Co., Miniature Lamp Dept.	Cleveland, Ohio	16352	Computer Diode Corp.	Lodi, N. J.
04222	Hi-Q Division of Aerovox	Myrtle Beach, S. C.	08984	Mel-Rain	Indianapolis, Ind.	16554	Electroid Co.	Union, N. J.
04354	Precision Paper Tube Co.	Wheeling, Ill.	09026	Babcock Relays Div.	Costa Mesa, Cal.	16585	Boots Aircraft Nut Corp.	Pasadena, Cal.
04404	Palo Alto Division of Hewlett-Packard Co.	Palo Alto, Cal.	09097	Electronic Enclosures Inc.	Los Angeles, Calif.	16688	Ideal Prec. Meter Co., Inc., De Jur Meter Div.	Brooklyn, N. Y.
04651	Sylvania Electric Products, Microwave Device Div.	Mountain View, Cal.	09134	Texas Capacitor Co.	Houston, Texas	16758	Delco Radio Div. of G. M. Corp.	Kokomo, Ind.
04673	Dakota Engr. Inc.	Culver City, Cal.	09145	Tech. Ind. Inc. Atohm Elect.	Burbank, Cal.	17109	Thermonetics Inc.	Canoga Park, Cal.
04713	Motorola Inc. Semiconductor Prod. Div.	Phoenix, Arizona	09250	Electro Assemblies, Inc.	Chicago, Ill.	17474	Tranex Company	Mountain View, Cal.
04732	Filtcon Co., Inc. Western Div.	Culver City, Cal.	09353	C & K Components Inc.	Newton, Mass.	17675	Hamlin Metal Products Corp.	Akron, Ohio
04773	Automatic Electric Co.	Northlake, Ill.	09569	Mallory Battery Co. of Canada, Ltd.	Toronto, Ontario, Canada	17745	Angstrom Prec. Inc.	No. Hollywood, Cal.
04796	Sequoia Wire Co.	Redwood City, Cal.	09795	Pennsylvania Florocarbon	Clifton Heights, Penn.	17856	Siliconix Inc.	Sunnyvale, Cal.
04811	Precision Coil Spring Co.	El Monte, Cal.	09922	Burdny Corp.	Norwalk, Conn.	17870	McGraw-Edison Co.	Manchester, N. H.
04870	P. M. Motor Company	Westchester, Ill.	10214	General Transistor Western Corp.	Los Angeles, Cal.	18042	Power Design Pacific Inc.	Palo Alto, Cal.
04919	Component Mfg. Service Co.	W. Bridgewater, Mass.	10411	Ti-Tal, Inc.	Berkeley, Cal.	18083	Clevite Corp. Semiconductor Div.	Palo Alto, Cal.
05006	Twentieth Century Plastics, Inc.	Los Angeles, Cal.	10646	Carborundum Co.	Niagara Falls, N. Y.	18324	Signetics Corp.	Sunnyvale, Cal.
05277	Westinghouse Electric Corp. Semiconductor Dept.	Youngwood, Pa.				18476	Ty-Car Mfg. Co., Inc.	Holliston, Mass.
						18486	TRW Elect. Comp. Div.	Des Plaines, Ill.
						18565	Chomerics	Plainville, Mass.
						18583	Curtis Instrument, Inc.	Mt. Kisco, N. Y.
						18612	Vishay Instruments Inc.	Malvern, Pa.
						18873	E. I. DuPont and Co., Inc.	Wilmington, Del.
						18911	Durant Mfg. Co.	Milwaukee, Wis.
						19315	The Bendix Corp., Navigation & Control Div.	Teterboro, N. J.
						19500	Thomas A. Edison Industries, Div. of McGraw-Edison	West Orange, N. J.
						19589	Concoa	Baldwin Park, Cal.

00015-49
Revised: May, 1970

From: Handbook Supplements
H4-1 Dated January 1970

Table 6-3. Code List of Manufacturers (Continued)

Code No.	Manufacturer	Address	Code No.	Manufacturer	Address	Code No.	Manufacturer	Address
19644	LRC Electronics	Horseheads, N. Y.	71482	C. P. Clare & Co.	Chicago, Ill.	78452	Thompson-Bremier & Co.	Chicago, Ill.
19701	Electra Mfg. Co.	Independence, Kansas	71590	Centralab Div. of Globe Union Inc.	Milwaukee, Wis.	78471	Tilley Mfg. Co.	San Francisco, Cal.
20183	General Atomics Corp.	Philadelphia, Pa.	71616	Commercial Plastics Co.	Chicago, Ill.	78488	Stackpole Carbon Co.	St. Marys, Pa.
21226	Executone, Inc.	Long Island City, N. Y.	71700	Cornish Wire Co., The	New York, N. Y.	78493	Standard Thomson Corp.	Waltham, Mass.
21355	Fafnir Bearing Co., The	New Britain, Conn.	71707	Coto Coil Co., Inc.	Providence, R. I.	78553	Timmerman Products, Inc.	Cleveland, Ohio
21520	Fansteel Metallurgical Corp.	N. Chicago, Ill.	71744	Chicago Miniature Lamp Works	Chicago, Ill.	78790	Transformer Engineers	San Gabriel, Cal.
23020	General Reed Co.	Metuchen, N. J.	71785	Cinch Mfg. Co.	Chicago, Ill.	78947	Ucinite Co.	Newtonville, Mass.
23042	Texascan Corp.	Indianapolis, Ind.	71984	Howard B. Jones Div.	Chicago, Ill.	79136	Waldes Kohinoor Inc.	Long Island City, N. Y.
23783	British Radio Electronics Ltd.	Washington, D.C.	72136	Dow Corning Corp.	Midland, Mich.	79142	Veeder Root, Inc.	Hartford, Conn.
24455	G. E. Lamp Division, Nela Park	Cleveland, Ohio	72619	Electro Motive Mfg. Co., Inc.	Willimant, Conn.	79251	Wenco Mfg. Co.	Chicago, Ill.
24655	General Radio Co.	West Concord, Mass.	72656	Indiana General Corp.	Brooklyn, N. Y.	79727	Continental-Wirt Electronics Corp.	Philadelphia, Pa.
24681	Memcor Inc., Comp. Div.	Huntington, Ind.	72659	Electronics Div.	Keasby, N. J.	79963	Zierick Mfg. Corp.	New Rochelle, N. Y.
26365	Gries Reproducer Corp.	New Rochelle, N. Y.	72765	General Instrument Corp.	Newark, N. J.	80031	Mepro Division of Sessions Clock Co.	Morristown, N. J.
26462	Grobert File Co. of America, Inc.	Carlstadt, N. J.	72766	Cap Division	Harwood Heights, Ill.	80033	Prestole Corp.	Toledo, Ohio
26851	Compac Hollister Co.	Hollister, Cal.	72825	Drake Mfg. Co.	Philadelphia, Pa.	80120	Schnitzer Alloy Products Co.	Elizabeth, N. J.
26992	Hamilton Watch Co.	Lancaster, Pa.	72928	Hugh H. Eby Inc.	Chicago, Ill.	80131	Electronic Industries Association	Standard tube or semi-conductor device, any manufacturer.
28480	Hewlett-Packard Co.	Palo Alto, Cal.	72962	Gudeman Co.	Union, N. J.	80207	Unimax Switch, Div. Maxon Electronics Corp.	Wallingford, Conn.
28520	Heyman Mfg. Co.	Kenilworth, N. J.	72964	Elastic Stop Nut Corp.	Erie, Pa.	80223	United Transformer Corp.	New York, N. Y.
30817	Instrument Specialties Co., Inc.	Little Falls, N. J.	72982	Robert M. Hadley Co.	Los Angeles, Cal.	80248	Oxford Electric Corp.	Chicago, Ill.
33173	G. E. Receiving Tube Dept.	Owensboro, Ky.	73061	Eric Technological Products, Inc.	Princeton, Ind.	80294	Bouras Inc.	Riverside, Cal.
35434	Lectrohm Inc.	Chicago, Ill.	73076	Hansen Mfg. Co., Inc.	Chicago, Ill.	80411	Arco Div. of Robertshaw Controls Co.	Columbus, Ohio
36196	Stanwyck Coil Products	Hawkesbury, Ontario, Canada	73138	H. M. Harper Co.	Chicago, Ill.	80486	All Star Products Inc.	Cleveland, Ohio
36287	Cunningham, W. H. & Hill Ltd.	Toronto, Ontario, Canada	73293	Helipot Div. of Beckman Inst., Inc.	Fullerton, Cal.	80509	Avery Label Co.	Monrovia, Cal.
37942	P. R. Mallory & Co., Inc.	Indianapolis, Ind.	73445	Hughes Products Division of Hughes Aircraft Co.	Newport Beach, Cal.	80583	Hammarlund Co., Inc.	Mars Hill, N. C.
39543	Mechanical Industries Prod. Co.	Akron, Ohio	73506	Amperex Elect. Co.	Hicksville, L. I., N. Y.	80640	Stevens, Arnold, Co., Inc.	Boston, Mass.
40920	Miniature Precision Bearings, Inc.	Keene, N. H.	73559	Bradley Semiconductor Corp.	New Haven, Conn.	80813	Dimco Gray Co.	Dayton, Ohio
40931	Honeywell Inc.	Minneapolis, Minn.	73586	Carling Electric, Inc.	Hartford, Conn.	81030	International Inst. Inc.	Orange, Conn.
42190	Muter Co.	Chicago, Ill.	73586	Circle F Mfg. Co.	Trenton, N. J.	81073	Grayhill Co.	LaGrange, Ill.
43990	C. A. Norgren Co.	Englewood, Colo.	73682	George K. Garrett Co.	Philadelphia, Pa.	81095	Triad Transformer Corp.	Venice, Cal.
44655	Ohmite Mfg. Co.	Skokie, Ill.	73734	Div. MSL Industries, Inc.	Philadelphia, Pa.	81312	Winchester Elec. Div. Litton Ind., Inc.	Oakville, Conn.
46384	Penn Eng. & Mfg. Corp.	Doylestown, Pa.	73743	Federal Screw Products, Inc.	Chicago, Ill.	81349	Military Specification	El Segundo, Cal.
47904	Polaroid Corp.	Cambridge, Mass.	73743	Fischer Special Mfg. Co.	Cincinnati, Ohio	81483	International Rectifier Corp.	El Segundo, Cal.
48620	Precision Thermometer & Inst. Co.	Southampton, Pa.	73793	General Industries Co., The	Elyria, Ohio	81541	Airpax Electronics, Inc.	Cambridge, Maryland
49956	Microwave & Power Tube Div.	Waltham, Mass.	73846	Goshen Stamping & Tool Co.	Goshen, Ind.	81860	Barry Controls, Div. Barry Wright Corp.	Watertown, Mass.
52090	Rowan Controller Co.	Westminster, Md.	73899	JFD Electronics Corp.	Brooklyn, N. Y.	82042	Carter Precision Electric Co.	Skokie, Ill.
52983	HP Co. Med. Elec. Div.	Waltham, Mass.	73905	Jennings Radio Mfg. Corp.	San Jose, Cal.	82047	Sperli Faraday Inc.	Copper Hewitt Electric Div.
54294	Shalleross Mfg. Co.	Selma, N. C.	73957	Groove-Pin Corp.	Ridgefield, N. J.	82116	Electric Regulator Corp.	Norwalk, Conn.
55026	Simpson Electric Co.	Chicago, Ill.	74276	Signalite Inc.	Neptune, N. J.	82142	Jeffers Electronics Division of Speer Carbon Co.	Du Bois, Pa.
55933	Somotone Corp.	Elmsford, N. Y.	74455	J. H. Winns and Sons	Winchester, Mass.	82170	Fairchild Camera & Inst. Corp.	Space & Defense Systems Div.
55938	Raytheon Co. Commercial Apparatus & System Div.	So. Norwalk, Conn.	74461	Industrial Condenser Corp.	Chicago, Ill.	82209	Maguire Industries, Inc.	Greenwich, Conn.
56137	Spaulding Fibre Co., Inc.	Tonawanda, N. Y.	74868	R. F. Products Division of Amphelol-Borg Electronic Corp.	Danbury, Conn.	82219	Sylvania Electric Prod., Inc.	Electronic Tube Division
56289	Sprague Electric Co.	North Adams, Mass.	74970	E. F. Johnson Co.	Waseca, Minn.	82376	Astron Corp.	East Newark, Harrison, N. J.
58474	Superior Elect. Co.	Bristol, Conn.	75042	International Resistance Co.	Philadelphia, Pa.	82389	Switchcraft, Inc.	Chicago, Ill.
59446	Telex Corp.	Tulsa, Okla.	75263	Keystone Carbon Co., Inc.	St. Marys, Pa.	82647	Metals & Controls Inc.	Spencer Products
59730	Thomas & Betts Co.	Elizabeth, N. J.	75378	CTS Knights, Inc.	Sandwich, Ill.	82768	Phillips-Advance Control Co.	Joliet, Ill.
60740	Triplet Electrical Inst. Co.	Bluffton, Ohio	75382	Kulka Electric Corp.	Mt. Vernon, N. Y.	82866	Research Products Corp.	Madison, Wis.
61775	Union Switch and Signal Div. of Westinghouse Air Brake Co.	Pittsburgh, Pa.	75518	Lenz Electric Mfg. Co.	Chicago, Ill.	82877	Rolton Mfg. Co., Inc.	Woodstock, N. Y.
62119	Universal Electric Co.	Owosso, Mich.	75915	Littlefuse, Inc.	Des Plaines, Ill.	82893	Vector Electronic Co.	Glendale, Cal.
63743	Ward-Leonard Electric Co.	Mt. Vernon, N. Y.	76005	Lord Mfg. Co.	Erie, Pa.	83058	Carr Fastener Co.	Cambridge, Mass.
64959	Western Electric Co., Inc.	New York, N. Y.	76210	C. W. Marwedel	San Francisco, Cal.	83086	New Hampshire Ball Bearing, Inc.	Peterborough, N. H.
65092	Weston Inst. Inc.	Weston-Newark, Newark, N. J.	76433	General Instrument Corp.	Newark, N. J.	83125	General Instrument Corp.	Capacitor Div.
66295	Wittek Mfg. Co.	Chicago, Ill.	76487	Micamold Division	Malden, Mass.	83148	ITT Wire and Cable Div.	Los Angeles, Cal.
66346	Minnesota Mining & Mfg. Co.	St. Paul, Minn.	76493	James Millen Mfg. Co., Inc.	Los Angeles, Cal.	83186	Victory Eng. Corp.	Springfield, N. J.
70276	Allen Mfg. Co.	Hartford, Conn.	76530	J. W. Miller Co.	Los Angeles, Cal.	83298	Bendix Corp.	Red Bank, N. J.
70309	Allied Control	New York, N. Y.	76545	Cinch-Monadnock Div. of United Carr Fastener Corp.	San Leandro, Cal.	83315	Hubbell Corp.	Mundelein, Ill.
70318	Allmetal Screw Product Co., Inc.	Garden City, N. Y.	76703	Mueller Electric Co.	Cleveland, Ohio	83324	Rosan Inc.	Newport Beach, Cal.
70417	Amplex, Div. of Chrysler Corp.	Detroit, Mich.	76854	National Union	Newark, N. J.	83330	Smith, Herman H., Inc.	Brooklyn, N. Y.
70485	Atlantic India Rubber Works, Inc.	Chicago, Ill.	77068	Oak Manufacturing Co.	Crystal Lake, Ill.	83332	Tech Labs	Palisades Park, N. J.
70563	Amperite Co., Inc.	Union City, N. J.	77068	The Bendix Corp.	Electrodynamics Div.	83385	Central Screw Co.	Chicago, Ill.
70674	ADC Products Inc.	Minneapolis, Minn.	77075	Pacific Metals Co.	San Francisco, Cal.	83501	Gavitt Wire and Cable Co., Div. of Ameracorp	Brookfield, Mass.
70903	Delden Mfg. Co.	Chicago, Ill.	77221	Phaostran Instrument and Electronic Co.	So. Pasadena, Cal.	83594	Burrroughs Corp., Electronic Tube Div.	Plainfield, N. J.
70998	Bird Electric Corp.	Cleveland, Ohio	77252	Philadelphia Steel and Wire Corp.	Philadelphia, Pa.	83740	Union Carbide Corp., Consumer Prod. Div.	New York, N. Y.
71002	Birnbach Radio Co.	New York, N. Y.	77342	American Machine & Foundry Co.	Potter & Brumfield Div.	83777	Model Eng. and Mfg., Inc.	Huntington, Ind.
71034	Bliley Electric Co., Inc.	Erie, Pa.	77630	TRW Electronic Components Div.	Camden, N. J.	83821	Loyd Scruggs Co.	Festus, Mo.
71041	Boston Gear Works Div. of Murray Co. of Texas	Quincey, Mass.	77638	General Instrument Corp.	Rectifier Division	83942	Aeronautical Inst. & Radio Co.	Lodi, N. J.
71218	Bud Radio, Inc.	Willoughby, Ohio	77764	Resistance Products Co.	Harrisburg, Pa.	84171	Arco Electronics Inc.	Great Neck, N. Y.
71279	Cambridge Thermionics Corp.	Cambridge, Mass.	77969	Rubbercraft Corp. of Calif.	Torrance, Cal.	84396	A. J. Glesener Co., Inc.	San Francisco, Cal.
71286	Camloc Fastener Corp.	Paramus, N. J.	78189	Shakeproof Division of Illinois Tool Works	Elgin, Ill.	84411	TRW Capacitor Div.	Ogallala, Neb.
71313	Cardwell Condenser Corp.	Lindenhurst, L. I., N. Y.	78277	Signal	So. Braintree, Mass.			
71400	Bussmann Mfg. Div. of McGraw-Edison Co.	St. Louis, Mo.	78283	Signal Indicator Corp.	New York, N. Y.			
71436	Chicago Condenser Corp.	Chicago, Ill.	78290	Struthers-Dunn Inc.	Pitman, N. J.			
71447	Calif. Spring Co., Inc.	Pico-Rivera, Cal.						
71450	CTS Corp.	Elkhart, Ind.						
71468	ITT Cannon Electric Inc.	Los Angeles, Cal.						
71471	Cinema, Div. Aerovox Corp.	Burbank, Cal.						

00015-49
Revised: May, 1970From: Handbook Supplements
H4-1 Dated January 1970

Table 6-3. Code List of Manufacturers (Continued)

Code No.	Manufacturer	Address	Code No.	Manufacturer	Address	Code No.	Manufacturer	Address
94870	Sarkes Tarzian, Inc.	Bloomington, Ind.	91929	Honeywell Inc., Micro Switch Division	Freeport, Ill.	96095	Hi-Q Div. of Aerovox Corp.	Olean, N. Y.
85454	Boonton Molding Company	Boonton, N. J.				96256	Thordarson-Meissner Inc.	Mt. Carmel, Ill.
85471	A. B. Boyd Co.	San Francisco, Cal.	91961	Nahm-Bros. Spring Co.	Oakland, Cal.	96296	Solar Mfg. Co.	Los Angeles, Cal.
85474	R. M. Bracamonte & Co.	San Francisco, Cal.	92180	Tru-Connector Corp.	Peabody, Mass.	96396	Microswitch, Div. of	
85660	Koiled Kords, Inc.	Hamden, Conn.	92367	Elgeet Optical Co., Inc.	Rochester, N. Y.		Minn.-Honeywell	Freeport, Ill.
85911	Seamless Rubber Co.	Chicago, Ill.	92607	Tensolite Insulated Wire Co., Inc.		96330	Carlton Screw Co.	Chicago, Ill.
86174	Fafnir Bearing Co.	Los Angeles, Calif.				96341	Microwave Associates, Inc.	Burlington, Mass.
86197	Clifton Precision Products Co., Inc.	Clifton Heights, Pa.	92702	IMC Magnetics Corp.	Westbury, L. I., N. Y.	96501	Excel Transformer Co.	Oakland, Cal.
86579	Precision Rubber Products Corp.	Dayton, Ohio	92966	Hudson Lamp Co.	Kearney, N. J.	96508	Xcelite, Inc.	Orchard Park, N. Y.
86684	Radio Corp. of America, Electronic Comp. & Devices Division	Harrison, N. J.	93332	Sylvania Electric Prod. Inc.		96733	San Fernando Elec. Mfg. Co.	San Fernando, Cal.
86928	Seastrom Mfg. Co.	Glendale, Cal.	93369	Robbins & Myers Inc.	Pallisades Park, N. J.	96881	Thomson Ind. Inc.	Long Island, N. Y.
87034	Marco Industries	Anaheim, Cal.	93410	Stemo Controls, Div. of Essex Wire Corp.	Mansfield, Ohio	97464	Industrial Retaining Ring Co.	Irvington, N. J.
87216	Philco Corporation (Lansdale Division)	Lansdale, Pa.	93632	Waters Mfg. Co.	Culver City, Cal.	97539	Automatic & Precision Mfg.	Englewood, N. J.
87473	Western Fibrous Glass Products Co.	Lansdale, Pa.	93929	G. V. Controls	Livingston, N. J.	97979	Reon Resistor Corp.	Yonkers, N. Y.
87664	Van Waters & Rogers Inc.	San Francisco, Cal.	94137	General Cable Corp.	Bayonne, N. J.	97983	Litton System Inc., Adler-Westrex Commun. Div.	New Rochelle, N. Y.
87930	Tower Mfg. Corp.	Providence, R. I.	94144	Raytheon Co., Comp. Div.	Quincy, Mass.	98141	R-Tronics, Inc.	Jamaica, N. Y.
88140	Cutler-Hammer, Inc.	Lincoln, Ill.	94148	Scientific Electronics Products, Inc.	Loveland, Colo.	98159	Rubber Teck, Inc.	Gardena, Cal.
88220	Gould-National Batteries, Inc.	St. Paul, Minn.	94154	Wagner Elect. Corp.		98220	Hewlett-Packard Co., Medical Elec. Div.	Pasadena, Cal.
88698	General Mills, Inc.	Buffalo, N. Y.	94197	Curtiss-Wright Corp., Electronics Div.	East Patterson, N. J.	98278	Microdut, Inc.	So. Pasadena, Cal.
89231	Graybar Electric Co.	Oakland, Cal.	94222	South Chester Corp.	Chester, Pa.	98291	Sealectro Corp.	Mamaronech, N. Y.
89473	G. E. Distributing Corp.	Schenectady, N. Y.	94330	Wire Cloth Products, Inc.	Bellwood, Ill.	98376	Zero Mfg. Co.	Burbank, Cal.
89479	Security Co.	Detroit, Mich.	94375	Automatic Metal Products Co.	Brooklyn, N. Y.	98410	Etc. Inc.	Cleveland, Ohio
89665	United Transformer Co.	Chicago, Ill.	94682	Worcester Pressed Aluminum Corp.	Worcester, Mass.	98731	General Mills Inc., Electronics Div.	
90030	United Shoe Machinery Corp.	Beverly, Mass.	94696	Magnecraft Electric Co.	Chicago, Ill.	98734	Pacco Division of Hewlett-Packard Co.	Palo Alto, Cal.
90179	U. S. Rubber Co., Consumer Ind. & Plastics Prod. Div.	Passaic, N. J.	95023	George A. Philbrick Researchers, Inc.	Boston, Mass.	98821	North Hills Electronics, Inc.	Glen Cove, N. Y.
90365	Belleville Speciality Tool Mfg., Inc.	Belleville, Ill.	95146	Airo Elect. Mfg. Co.	Lawrence, Mass.	98978	International Electronic Research Corp.	Burbank, Cal.
90763	United Carr Fastener Corp.	Chicago, Ill.	95236	Allies Products Corp.	Dania, Fla.	99109	Columbia Technical Corp.	New York, N. Y.
90970	Bearing Engineering Co.	San Francisco, Cal.	95238	Continental Connector Corp.	Woodside, N. Y.	99313	Varian Associates	Palo Alto, Cal.
91146	ITT Cannon Elect. Inc., Salem Div.	Salem, Mass.	95263	Leecraft Mfg. Co., Inc.	Long Island, N. Y.	99378	Atlee Corp.	Winchester, Mass.
91260	Connor Spring Mfg. Co.	San Francisco, Cal.	95265	National Coil Co.	Sheridan, Wyo.	99515	Marshall Ind., Capacitor Div.	Monrovia, Cal.
91345	Miller Dial & Nameplate Co.	El Monte, Cal.	95275	Vitramon, Inc.	Bridgeport, Conn.	99707	Control Switch Division, Controls Co. of America	El Segundo, Cal.
91418	Radio Materials Co.	Chicago, Ill.	95348	Gordos Corp.	Bloomfield, N. J.	99800	Delevan Electronics Corp.	East Aurora, N. Y.
91506	Augat Inc.	Attleboro, Mass.	95354	Methodo Mfg. Co.	Rolling Meadows, Ill.	99848	Wilco Corporation	Indianapolis, Ind.
91637	Dale Electronics, Inc.	Columbus, Nebr.	95566	Arnold Engineering Co.	Marengo, Ill.	99928	Branson Corp.	Whippany, N. J.
91662	Eleo Corp.	Willow Grove, Pa.	95712	Dage Electric Co., Inc.	Franklin, Ind.	99934	Rembrandt, Inc.	Boston, Mass.
91673	Epiphone Inc.	New York, N. Y.	95984	Siemon Mfg. Co.	Wayne, Ill.	99942	Hoffman Electronics Corp., Semiconductor Division	El Monte, Cal.
91737	Gremar Mfg. Co., Inc.	Wakefield, Mass.	95987	Weckesser Co.	Chicago, Ill.	99957	Technology-Instrument Corp. of California	Newbury Park, Cal.
91827	K F Development Co.	Redwood City, Cal.	96067	Microwave Assoc. West, Inc.	Sunnyvale, Cal.			
91886	Malco Mfg., Inc.	Chicago, Ill.						

The following HP Vendors have no number assigned in the latest supplement to the Federal Supply Code for Manufacturers Handbook.

0000F	Malco Tool and Die	Los Angeles, Calif.	000CS	Hewlett-Packard Co., Colorado Springs Div.	Colorado Springs, Colorado	000QQ	Cooltron	Oakland, Cal.
0000Z	Willow Leather Products Corp.	Newark, N. J.	000MM	Rubber Eng. & Development	Hayward, Cal.	000WW	California Eastern Lab.	Burlington, Cal.
000AB	ETA	England	000NN	A "N" D Mfg. Co.	San Jose, Cal.	000YY	S. K. Smith Co.	Los Angeles, Cal.
000BB	Precision Instrument Comp. Co.	Van Nuys, Cal.						



MANUAL PART NO. 02752-9004
MICROFICHE PART NO. 02752-90045

PRINTED IN U.S.A.