

# MASTER DRAWING LIST

NO.	TITLE	UNIT VARIATIONS																				
		LT33-AA	LT33-AB	LT33-BA	LT33-BB	LT33-CA	LT33-GB	LT33-CC	LT33-CD	LT33-DA	LT33-DB	LT33-DC	LT33-DE	LT33-EA	LT33-EB	LT33-FA	LT33-FB	LT33-HA	LT33-HB	LT33-SB	LT33-SH	
LT33-0	TELETYPEWRITERS	X	X	X	X	X	X	X	X	X	X	X	X	X	X	X	X	X	X	X	X	X

USED ON OPTIONS

REV.	DATE	CHG. NO.	APP.D.	REVISIONS
7/69	3/71	LT33-1	M.A.	BAØ8-19
	7/71	LT33-2	W.M.	
	10/71	LT33-3	A&K.	

DRN.	R. BERNIER	DATE	3/68
CHK'D	D. HEALY	DATE	3/68
ENG.	FITZGERALD	DATE	5/68
PROJ. ENG.	FITZGERALD	DATE	5/68
PROD.	ANTONUCCIO	DATE	5/68
FIRST USED ON			
PDP10			
SCALE			
SHEET	1	OF	2

SIZE	CODE	NUMBER	REV.
A	ML	LT33-0	D



TELETYPEWRITERS  
LT33

DRA 131

Dec 16 (325)-1048-N471

PRINT SET	DWG. NO.	REV. NO. OF LET. SHEETS	TITLE	OPTION NO.
X	D-BS-LT33-B-CONT	B 1	READER CONTROL CIRCUITS	
X	D-IC-LT33A-0-1	A 1	PDP10 TELETYPE MODEL 33 KSR	
X	D-IA-7505038-0-0	C 2	TELETYPE MODIFICATIONS (LT33)	
X	D-IA-7505039-0-0	C 1	TELETYPE MODIFICATIONS (50 HZ & 240V)	
X	D-IA-7505041-0-0	B 1	TELETYPE MODIFICATION (33 KSR)	
X	A-AL-LT33-0-12	A 1	ACCESSORY LIST	
X	D-UA-LT33A-0-0	A 1	PDP10 TELETYPE 33 KSR	
X	D-UA-LT33-B-0	B 1	DEC MODIFIED TELETYPE 33 ASR	
X	A-PL-LT33A-0-0	A 1	PDP10 TELETYPE 33 KSR (PL)	
X	A-PL-LT33-B-0	B 1	DEC MODIFIED TELETYPE 33 ASR (PL)	
X	A-PL-LT33-SB-0	1	RECOMMENDED SPARE PARTS	
X	A-PL-LT33-ST-0	A 2	MAINTENANCE TOOL KIT 33 ASR	
X	A-SP-LT33-0-2	3	MODIFICATION PROCEDURE	
X	A-SP-LT33-0-6	A 4	ALIGNMENT PROCEDURE	
X	A-SP-LT33-0-10	A 1	PACKING PROCEDURE	
X	A-SP-LT33-0-11	A 1	INSTALLATION PROCEDURE	
X	A-SP-LT33-0-13	7	INCOMING INSPECTION PROCEDURE	
X	B-UA-4915-0-0	A 1	TELETYPE READER CONTROL	

TITLE	TELETYPEWRITERS LT33	SHEET	2	OF	2	SIZE	CODE	NUMBER	REV.
						A	ML	LT33-0	D

DRA 132

DEC 16 (325)-1048-1-N471

This drawing and specifications, herein, are the property of Digital Equipment Corporation and shall not be reproduced or copied or used in whole or in part as the basis for the manufacture or sale of items without written permission.

CABLE CONNECTIONS TO TERMINAL BOARD

NUMBER IN LUG CORRESPONDS TO TERMINAL BOARD NUMBERS

TTY. CABLE VARIATIONS

PROD LINE	CABLE NUMBER
PDP-8, 8L, 8LS	7006593-1 (12 FT) + WØ78
PDP-12, LINC 8	7006593-2 (18 FT) + WØ78
PDP-9, 9L	
PDP-8E, PDP-11	7006593-1 (12 FT)
PDP-15	7006593-2 (18 FT)

NOTES:

- ADDITIONAL ELECTRICAL CHANGES TO TERMINAL BOARD CONNECTIONS AND CALL CONTROL UNIT.
  - A. REMOVE BRN/YEL WIRE FROM LUG 3 & PLACE ON LUG 5.
  - B. REMOVE BLU/WHT WIRE FROM LUG 4 & PLACE ON LUG 5.
  - C. REMOVE PURPLE WIRE FROM LUG 8 & PLACE ON LUG 9.
  - D. MOVE BROWN WIRE ON PLUG #4 FROM LOCATION #11 TO LOCATION #7. (MATES WITH YEL/WHT WIRE FROM 4915)
  - E. MOVE BLUE WIRE FROM TERMINAL #3 TO TERMINAL #4 (END) OF 181816 POWER RESISTOR.
- MECHANICAL CHANGES
  - A. REMOVE SPRING & WRU PAWL UNIT FROM SLOT 'N' IN FUNCTION CASTING.
- A. ADD (2) 6RS20SP4B4 THYRACTORS DEC #1100106 TO UNIT & WIRE AS INDICATED BELOW USING ITEM #7

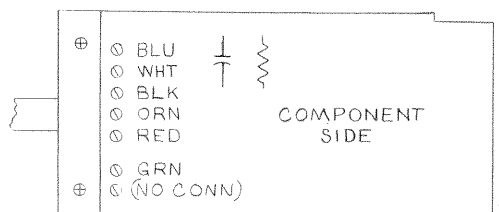
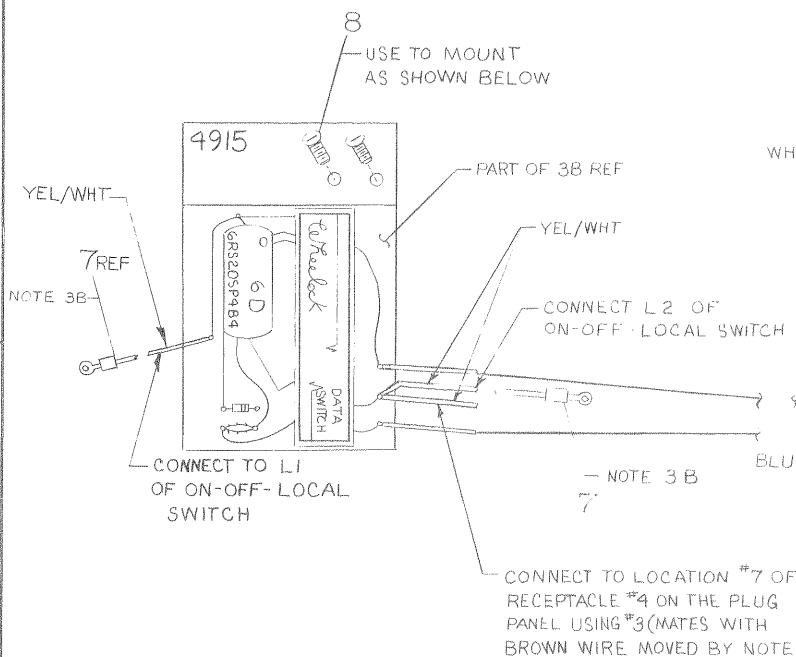

WØ76 REV 'D' CONN. (7005676)  
NOTE: YELLOW IS SOMETIMES USED INSTEAD OF WHITE. GRAY IS SOMETIMES USED INSTEAD OF GREEN.



PIN VIEW 7006593  
MATE-N-LOCK CONNECTOR

FROM	TO
THYRACTOR #1	CONN #2 L OF ON-OFF PWR SW
THYRACTOR #2	CONN 1 OF ON-OFF PWR SW

- B. USING ITEM #7 CONNECT YEL-WHT WIRES TO INDICATED TERMINALS OF ON-OFF-LOCAL SWITCH.
- C. USE ITEM #9 & #10 TO TIE WIRING.
- 4. TELETYPES FOR USE ON 50 HZ OR VOLTAGES OTHER THAN 115V ALSO REQUIRE MODIFICATION PER DWG. D-IA-7505039-0-0

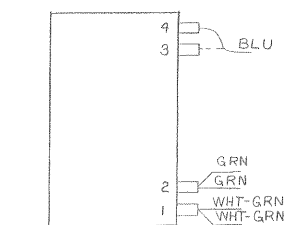

POWER RESISTOR  
DETAIL B  
SEE NOTE 1E

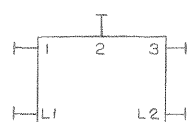

TERMINAL LOCATION  
VIEW A-A  
ON-OFF-LOCAL SWITCH  
SEE NOTE 3.

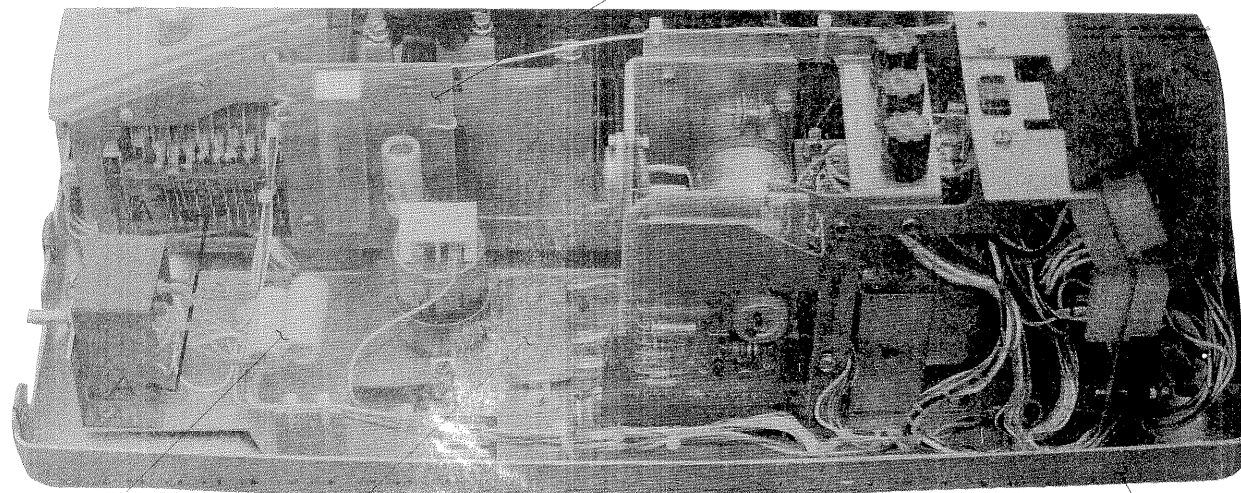

SEE NOTE 3A  
6RS20SP4B4 THYRACTORS

SEE DETAIL B

ASR-33 TELETYPE MODIFICATIONS & CABLE CONNECTIONS. (ALL UNITS USING RELAY CONTROLLED READER) 4915 CARD INSERTED

SUB BASE

QTY.	DESCRIPTION	PART NO.	ITEM NO.
1	MODULE, ADAPTER WØ78	WØ78	11
2	CABLE TIE 3/16 X 6-1/2 LG SST 2M	9007032	10
15	CABLE TIE 3/32 X 3-3/4 LG SST 1M	9007031	9
2	SCR. PH. PAN. HD. 6-32 X 1/4	9006020-1	8
5	SOLDERLESS TERM #6AWG 18-22	9007929	7
2	THYRACTOR GE 6RS20SP4B4	1100106	6
1	CABLE ASSY. MATE-N-LOCK TØ4915	7006593	5
1	PIN TELETYPE 182644	2911459	3
1	TTY. WRITER MODEL 33TU (60HZ)	3004779	2
1	TTY. WRITER MODEL 33TBP (50HZ)	3005716	1

FIRST USED ON OPTION/MODEL		PARTS LIST	
LT33-DA		TITLE	
UNLESS OTHERWISE SPECIFIED DIMENSION IN INCHES. TOLERANCES		TELETYPE MODIFICATIONS (LT33)	
DECIMALS	ANGLES	DRN. R. THELLEN	DATE 2-24-70
.XXX - .005	±0° 30'	CHK'D. K. RUSS	DATE 2-24-70
.XX - .02		ENG. W. DAVIS	DATE 3-3-70
.X - .1		PROJ. ENG. C. BLASI	DATE 3-3-70
REMOVE BURRS AND BREAK SHARP CORNERS. SURFACE QUALITY		PROD. T. MACDONALD	DATE 3-3-70
MATERIAL		NEXT HIGHER ASSY.	
FINISH		SCALE	
		SHEET 1 OF 2	
		SIZE CODE	NUMBER
		DIA 7505038-0-0	REV. C

REV.	CHANGE NO.	DATE
B	LT33-00002	2-20-71
C	LT33-00003	2-20-71

REV. C  
NUMBER  
DIA 7505038-0-0

This drawing and specifications, herein, are the property of Digital Equipment Corporation and shall not be reproduced or copied or used in whole or in part as the basis for the manufacture or sale of items without written permission.

REV. C  
 NUMBER DIA 7505038-0-0  
 SIZE CODE 2

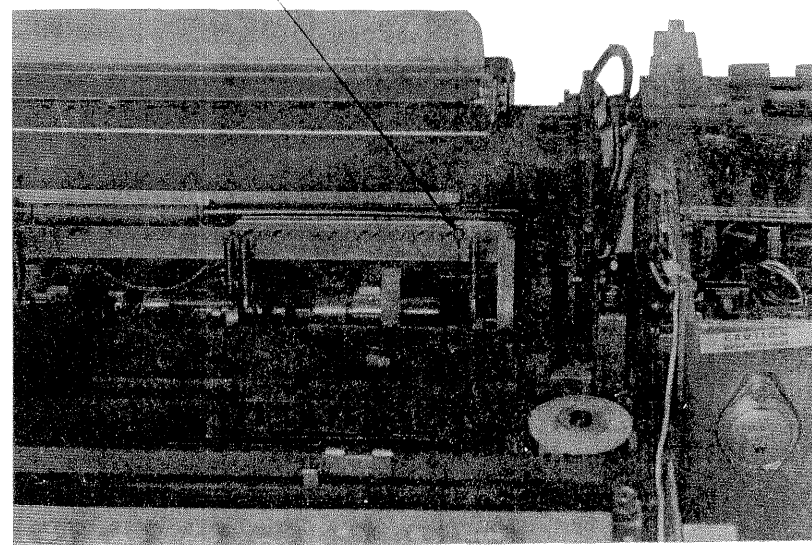

WRU PAWL SPRING  
 SEE NOTE 2A  
 PARTS TO BE REMOVED  
 INDICATED BY DASHED LINE

PLUG PANEL  
 SEE CABLE LAYOUT  
 SHEET 1 AND NOTE 1D

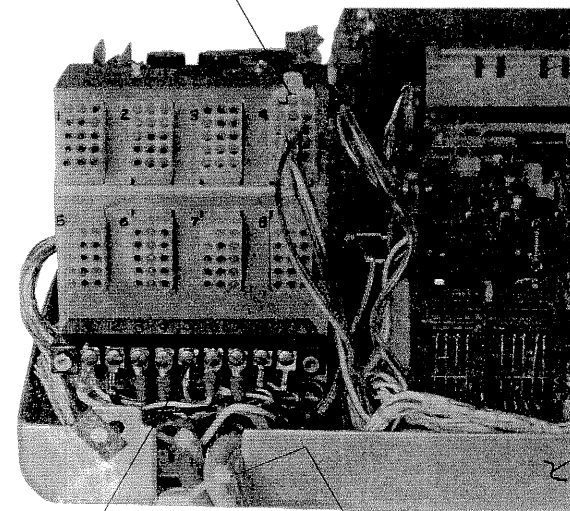

WIRING SIDE VIEW OF  
 PLUG #4. (PIN SIDE VIEW  
 OF RECEPTACLE #4)

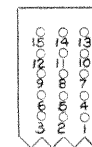

SUB BASE

SEE NOTE 1  
 TERMINAL BOARD  
 SECURE INTERFACE CABLE TO  
 CALL CONTROL UNIT AND  
 POWER CORD.

REV.	
CHANGE NO.	
CHK	

FIRST USED ON OPTION/MODEL  
 + + +

DO NOT SCALE DRAWING		
UNLESS OTHERWISE SPECIFIED		
DIMENSION IN INCHES		
TOLERANCES		
DECIMALS	FRACTIONS	ANGLES
±.005	± 1/64	± 0°30'
FINAL SURFACE QUALITY /		
REMOVE BURRS AND BREAK SHARP CORNERS		
MATERIAL	+ + +	
FINISH	+ + +	

QTY.	DESCRIPTION	PART NO.	ITEM NO.
PARTS LIST			
DRN	R. THELLEN	DATE	2-24-70
CHK'D	K. RUSS	DATE	2-24-70
ENG.	W. DAVIS	DATE	3-3-70
PROJ. ENG.	C. BLASI	DATE	3-3-70
PROD.	T. MACDONALD	DATE	3-3-70
NEXT HIGHER ASSY		+ + +	
SCALE	+ + +		
SHEET	2 OF 2		
TITLE		SIZE CODE	NUMBER
TELETYPE MODIFICATIONS (LT-33)		DIA	7505038-0-0
		REV.	C

REV. C  
 NUMBER DIA 7505038-0-0  
 SIZE CODE 2

This drawing and specifications, herein, are the property of Digital Equipment Corporation and shall not be reproduced or copied or used in whole or in part as the basis for the manufacture or sale of items without written permission.

0-0-620902/1A 2

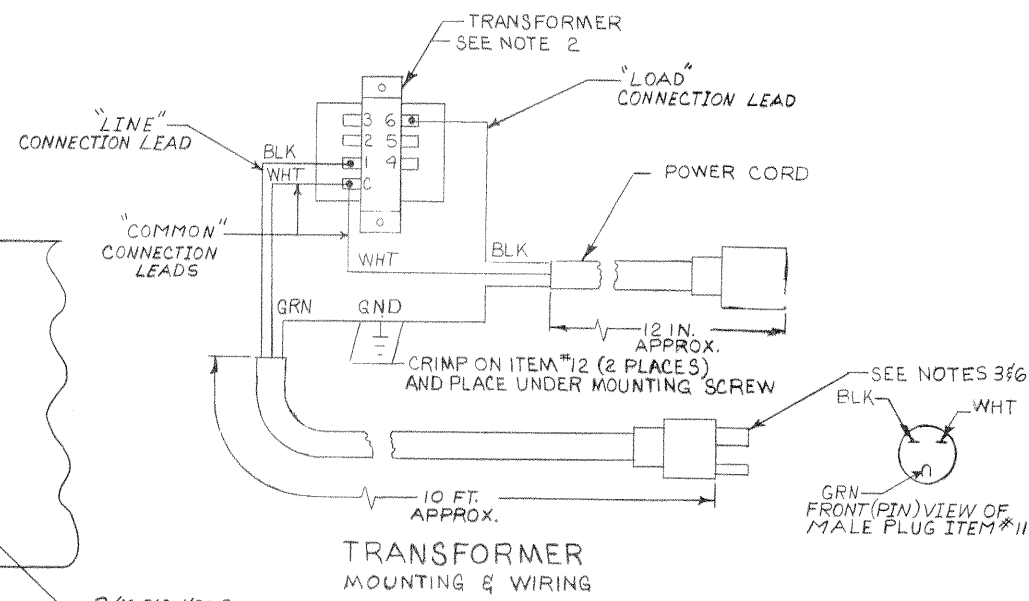
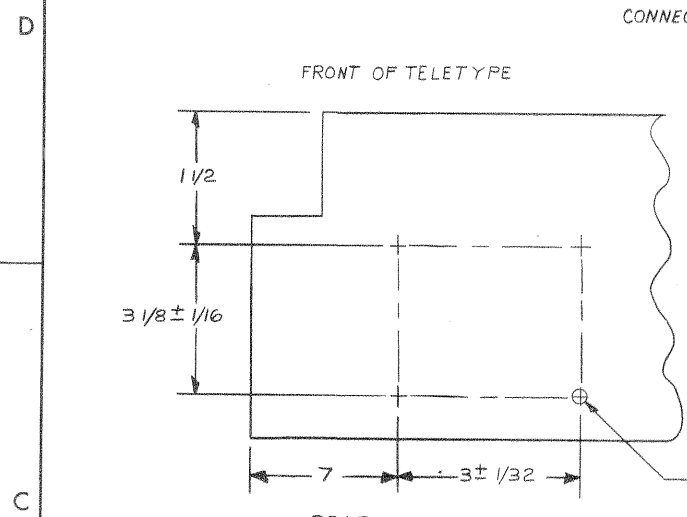

VOLTAGE	LINE	LOAD	COMMON	VOLTAGE	LINE	LOAD	COMMON
126	6	4	C	287	3	4	C
121	5	4	C	275	2	4	C
115	6	6	C	274	3	5	C
110	5	4	1	265	1	4	C
106	6	4	1	263	2	5	C
100*	1	3	4	260	3	6	C
96	C	1	5	252	1	5	C
90	C	2	5	250	2	6	C
85	C	3	6	240*	1	6	C
82	C	2	4	220	C	6	1
77	C	3	4	213	C	6	2
				198	C	5	3
				197	C	4	2
				193	C	4	3

\*INDICATES STD. FACTORY CONNECTIONS THIS TABLE PROVIDES 115V TO THE LOAD AT THE NOMINAL LINE VOLTAGE

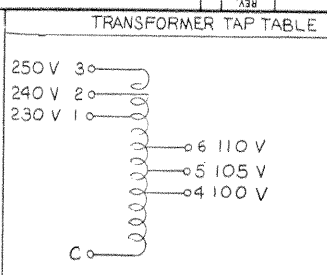

- NOTES:
- FOR 50 HZ OPERATION, PERFORM THE FOLLOWING CHANGES (NOT NECESSARY IF STARTING WITH TELETYPE 33 TBP):
    - REMOVE MOTOR AND REPLACE WITH ITEM #1 (NOT NECESSARY IF MOTOR WAS ALREADY 50/60 HZ ON NAME PLATE)
    - REMOVE DRIVE GEAR AND REPLACE WITH ITEM #2
    - REMOVE PINION GEAR AND REPLACE WITH ITEM #3
    - REMOVE PLATE WITH STUD AND REPLACE WITH ITEM #4. (181850 CAN BE USED WITH 50 OR 60 HZ)
  - FOR OPERATION ON VOLTAGES OTHER THAN 115V, PERFORM THE FOLLOWING OPERATIONS.
    - MOUNT ITEM #5 IN BASE OF TELETYPE STAND USING ITEM #6 THRU #9. DRILL HOLES PER PATTERN SHOWN. CUT ITEM #10 AND CONNECT AS SHOWN.
  - FOR OPERATION ON VOLTAGES FROM 190V TO 250V ON PDP8-E AND PDP11 TELETYPE CUT MALE PLUG OF POWER CORD AND REPLACE WITH ITEM #11. WIRE AS SHOWN.
  - SEE ALSO DWG. D-1A-7505038-0-0 WHEN RELAY CONTROLLED READER IS REQUIRED.
  - ADD FAN DEFLECTOR TO 50 HZ UNITS IF NOT ALREADY SUPPLIED.
  - IF NOT CUT OFF, PAINT MALE END OF ITEM #10 RED WHEN WIRED FOR 190V TO 250V.

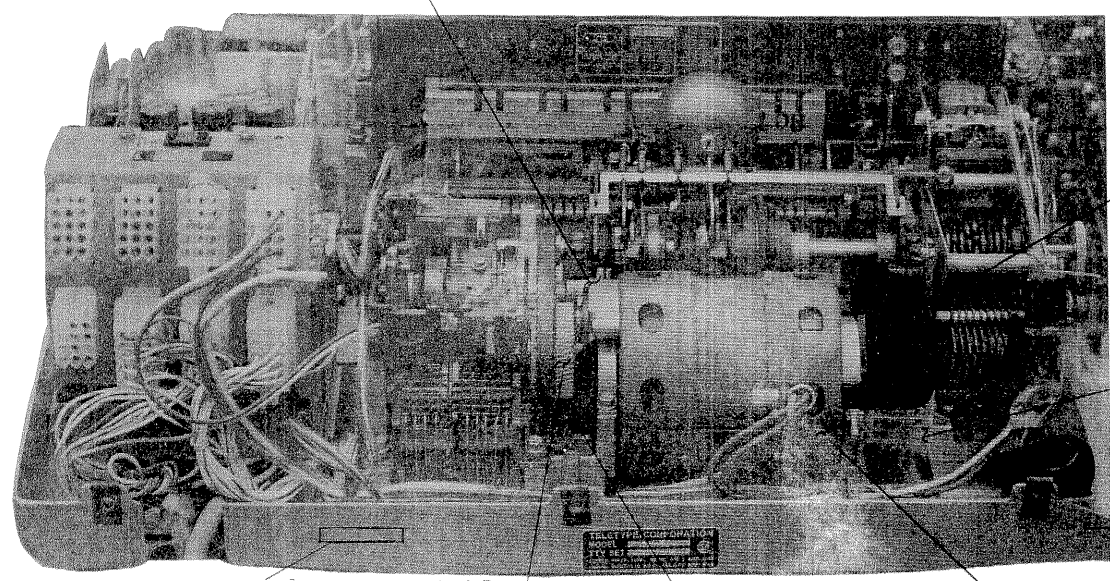

PLACE APPROPRIATE DECAL HERE INDICATING VOLTAGE AND FREQUENCY AFTER MODIFICATION.

SEE NOTE 1B DRIVE GEAR

SEE NOTE 1C

SEE NOTE 1A MOTOR

PINION GEAR

QTY.	DESCRIPTION	PART NO.	ITEM NO.
1	DECAL, VOLTAGE SPEC	7409045-2	13
2	SOLDERLESS CONN. #10 AWG 14-16	9007928	12
1	PLUG 220V	9008853	11
1	CORD SET 12 FT	9107673-12	10
4	HEX NUT 8-32 X 5/16 X 1/8	9006561	9
4	FLAT WASHER #8	9006650	8
4	LOCK WASHER #8	9006690	7
4	SCR. PAN HD 8-32 X 3/8	9006037-1	6
1	TRANSFORMER STEP-DOWN	1609313	5
1	PLATE W/STUD TELETYPE 181850	1204848	4
1	PINION GEAR 50HZ TTY. 181851	1204849	3
1	DRIVE GEAR 50HZ TTY. 181855	1204850	2
1	MOTOR 50HZ TTY. 182267	1204789	1

FIRST USED ON OPTION/MODEL	QTY.	DESCRIPTION	PART NO.	ITEM NO.
PARTS LIST				
UNLESS OTHERWISE SPECIFIED DIMENSION IN INCHES. TOLERANCES		DRN. R. THELLEN DATE 2-24-70		
DECIMALS	ANGLES	CHK'D. K. RUSS DATE 2-24-70		
.XXX = .005	±0° 30'	ENG. W. DAVIS DATE 3-3-70	TITLE <b>TELETYPE MODIFICATIONS (50 HZ &amp; 240V)</b>	
.XX = .02		PROJ. ENG. C. BLASI DATE 3-3-70		
.X = .1		PROD. T. MACDONALD DATE 3-3-70		
REMOVE BURRS AND BREAK SHARP CORNERS SURFACE QUALITY				
MATERIAL	NEXT HIGHER ASSY.			
FINISH	SCALE			
SHEET		OF		REV.
DIA		7505039-0-0		C

REV.	CHANGE NO.	BY	DATE
B	0002	LT	7/11
A	0001	LT	7/11

REVISIONS

CHK. CHANGE NO. REV. DATE

REVISED & REDRAWN

BY: G. G. 7-22-71

A-KENT

Allen Kent 28 July 71

LT 33-00003 C

cm - G. G. 10-22-71

A-KENT

Allen Kent 28 Oct 71



**DIGITAL EQUIPMENT CORPORATION**  
MAYNARD, MASSACHUSETTS  
**PARTS LIST**

MADE BY <i>C. Stephenson</i>	CHECKED D. HEALY	SECTION
DATE <i>9/25/68</i>	DATE <i>1-20-70</i>	1
ENG <i>Allan Kent</i>	PROD <i>C. McElliman</i>	ISSUED SECT.
DATE <i>30 Jan 70</i>	DATE <i>2-9-70</i>	1

QUANTITY / VARIATION

ITEM NO.	DWG NO. / PART NO.	DESCRIPTION	QUANTITY / VARIATION														
			LT33-BB 50 Hz	LT33-BA 60 Hz													
1	3004768	Send-Receive Set 33TY	1	1													
2		"ME" Typewheel Teletype 183 599	1	1													
3	12-05693	Cordset	1	1													
4	12-05857-1	283B Plug	1	1													
5	12-05857-2	404 B Jack	1	1													
6	1602583	Transformer Elgin 1725	1														
7	91-07673-12	Cordset 12 feet	1														
8	1204789	Motor Teletype 182267 50 Hz	1														
9	<b>1204850</b>	Drive Gear Teletype 181855	1														
10	1204849	PINION Gear Teletype 181851	1														
11	1204848	PINION Teletype 181850	1														
12	9006037-1	SCR PAN HD 8-32 x 3/8	4														
13	9006690	LOCK WASHER #8	4														
14	9006650	FLAT WASHER #8	4														
15	9006561	HEX NUT 8-32 x 5/16 x 1/8	4														
16	7409045-2	DECAL, VOLTAGE SPEC	1														

TITLE TIMESHARING TELETYPE 33 ASR (TY)	ASSY NO. D-UA-LT33-B-0	SIZE <b>A</b>	CODE <b>PL</b>	NUMBER LT33-B-0	REV. <b>B</b>	ECO NO. LT33- 00003
SHEET 1 OF 1		DIST.				

DEC FORM NO. DRA 110

This drawing and specifications, herein, are the property of Digital Equipment Corporation and shall not be reproduced or copied or used in whole or in part as the basis for the manufacture or sale of items without written permission.

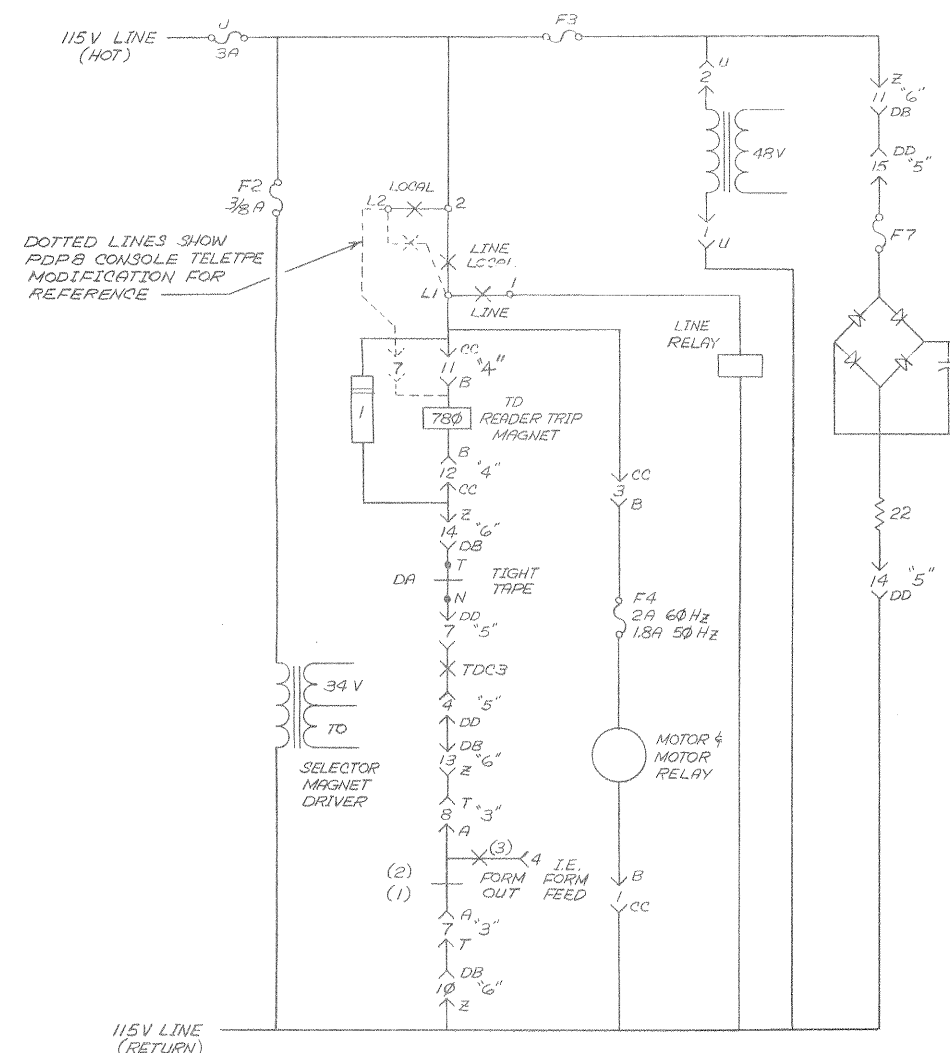

DOTTED LINES SHOW PDP-8 CONSOLE TELETYPE MODIFICATION FOR REFERENCE

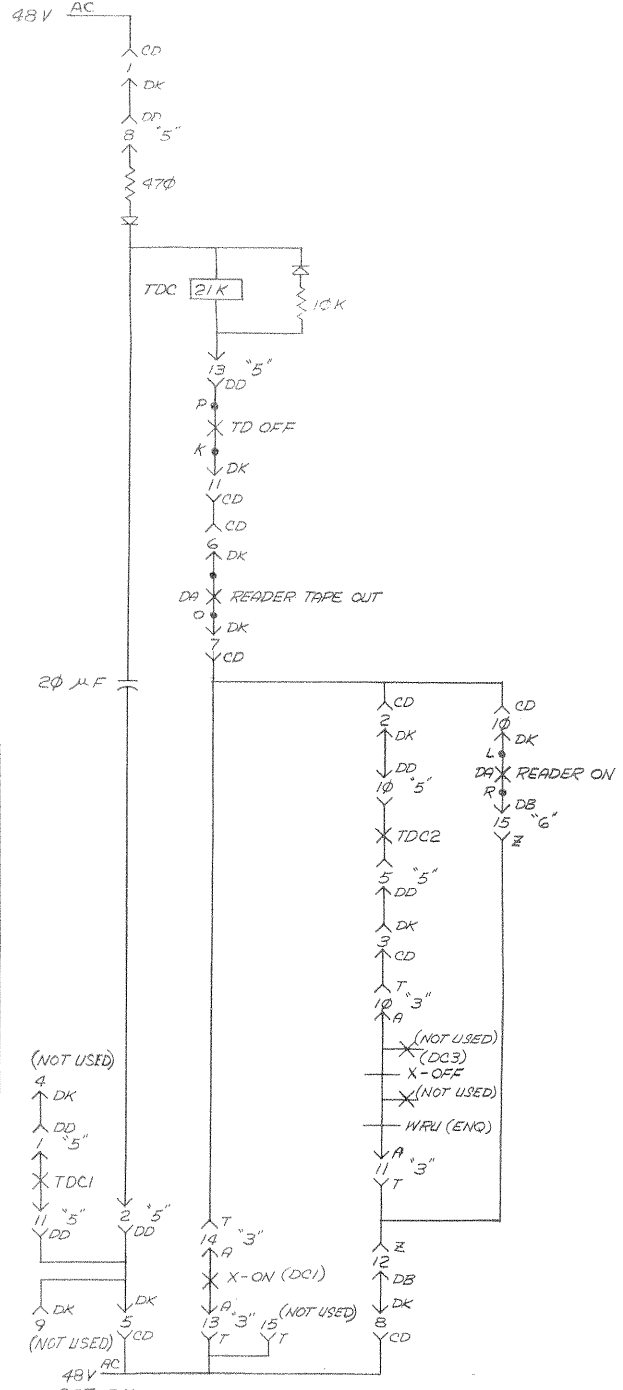
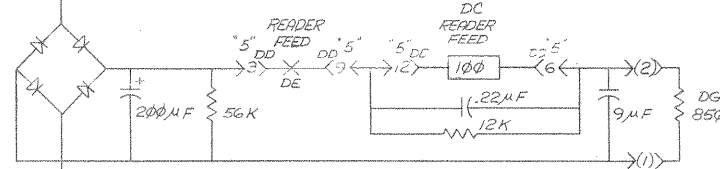

240V TRANSFORMER TAP TABLE				CONNECTOR CORRESPONDENCE			
VOLTAGE	LINE	LOAD	COMMON	VOLTAGE	LINE	LOAD	COMMON
287	5	4	C	126	6	4	C
275	5	4	C	121	5	4	C
274	5	5	C	115	6	6	C
265	1	4	C	110	5	4	1
263	2	5	C	106	6	4	1
260	5	6	C	100	1	3	4
252	1	5	C	96	C	1	5
250	2	6	C	90	C	2	5
240	1	6	C	85	C	3	6
220	C	6	1	82	C	2	4
213	C	6	2	82	C	2	4
213	C	5	1	77	C	3	4
206	C	6	3				
204	C	5	2				
203	C	4	1				
203	C	5	3				
197	C	4	2				
193	C	4	3				

THIS TABLE PROVIDES 115 V TO THE LOAD AT THE NOMINAL LINE VOLTAGE



REV	CHG	NO.	DATE	BY
1	A	00002	7-15-71	A. KENT
2	B	00003	10-21-71	A. KENT

FIRST USED ON OPTION/MODEL: PDP10

UNLESS OTHERWISE SPECIFIED: DIMENSION IN INCHES

TOLERANCES: DECIMALS ± .005, FRACTIONS ± 1/64, ANGLES ± 0°30'

FINAL SURFACE QUALITY: REMOVE BURRS AND BREAK SHARP CORNERS

MATERIAL: //

FINISH: //

DRN: J. Stephenson, DATE: 2/27/68

CHKD: J. Kent, DATE: 4-1-70

ENG: Allen Kent, DATE: 30/10/70

PROJ. ENG: Allen Kent, DATE: 30/10/70

PROD: J. M. Wilson, DATE: 2-9-70

NEXT HIGHER ASSY: A-ML-LT33-BA-0

SCALE: 1 OF 1

SHEET: 1 OF 1

TITLE: READER CONTROL CIRCUITS (ISOLATED DIAGRAM) [TIMESHARING ASR 33]

digital EQUIPMENT CORPORATION MAYNARD, MASSACHUSETTS

SIZE CODE: DBS LT33-B-CONT

NUMBER: B

REV: B

This drawing and specifications, herein, are the property of Digital Equipment Corporation and shall not be reproduced or copied or used in whole or in part as the basis for the manufacture or sale of items without written permission.

LEGEND	
NUMBER	VARIATIONS
LT33-BA	115V 60 Hz
LT33-BB	230V 50 Hz

- NOTES:
- REPLACE FURNISHED TYPING CYLINDER WITH SLASHED ZERO TYPING CYLINDER, "ME" PART NO. 2911511, TTY, PART NO. 183599.
  - DO NOT DISABLE FORM FEED, WRU (ENG), X-ON (DC<sub>1</sub>), X-OFF (DC<sub>3</sub>), TAPE ON (DC<sub>2</sub>) OR TAPE OFF (DC<sub>4</sub>) FEATURES FROM STUNT BOX.
  - DO NOT REMOVE PARITY GENERATION FROM KEYBOARD.
  - WIRE SHORT LEAD END OF ITEM 3 TO ITEM 4 AS FOLLOWS:
 

ITEM 3	ITEM 4
RED	R
GREEN	G
BLACK	B
YELLOW	Y

 INSERT EARBAND TAB OF ITEM 3 IN CENTER HOLE OF ITEM 4. INSTALL COVER OF ITEM 4 WITH RIDGE ON SAME SIDE AS WIDE SPACED (R & G) PINS.
  - SUPPLY ITEM 5 LOOSE WITH SET.
  - ARRANGE SET FOR 20 mA, FULL DUPLEX OPERATION AS FOLLOWS:
    - MOVE PURPLE WIRE FROM TERMINAL 8 TO TERMINAL 9 ON TERMINAL STRIP 151411 (X).
    - MOVE W-BL WIRE FROM TERMINAL 4 TO TERMINAL 5
    - MOVE BR-Y WIRE FROM TERMINAL 3 TO TERMINAL 5
    - MOVE BL WIRE FROM TERMINAL 3 TO TERMINAL 4 OF 151816 POWER RESISTOR (CH).
  - STRAIN RELIEVE ITEM 3 BY PLACING S-HOOK UNDER SCREW. CONNECT LONG LEAD END OF ITEM 3 TO TERMINAL STRIP OF ITEM 1 AS FOLLOWS:
 

ITEM 3	TERMINAL STRIP (X)
RED	3
GREEN	4
BLACK	7
YELLOW	6
  - CUT ITEM 7 APPROX 12 INCHES FROM FEMALE END. WIRE TO ITEM 8 AS FOLLOWS:
 

BOTH GREEN WIRES	FRAME
BOTH WHITE WIRES	C
FEMALE BLACK WIRE	6
MALE BLACK WIRE	1

 PAINT MALE END OF CORD RED. MOUNT ITEMS 7 AND 8 IN TELETYPE BASE WHEN REQUIRED (240 V OPERATION) USING ITEMS 12 THRU 15.
  - REPLACE FURNISHED MOTOR UNIT AND GEAR SET WITH ITEMS 8 AND 9 FOR 50 HZ OPERATION.
  - ADJUST FORM FEED MECHANISM FOR 11 INCH FORMS.

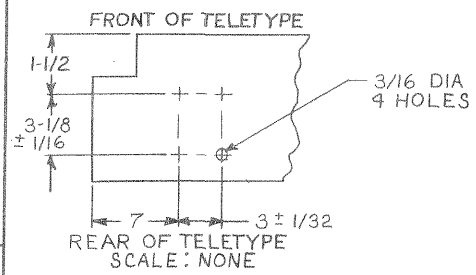
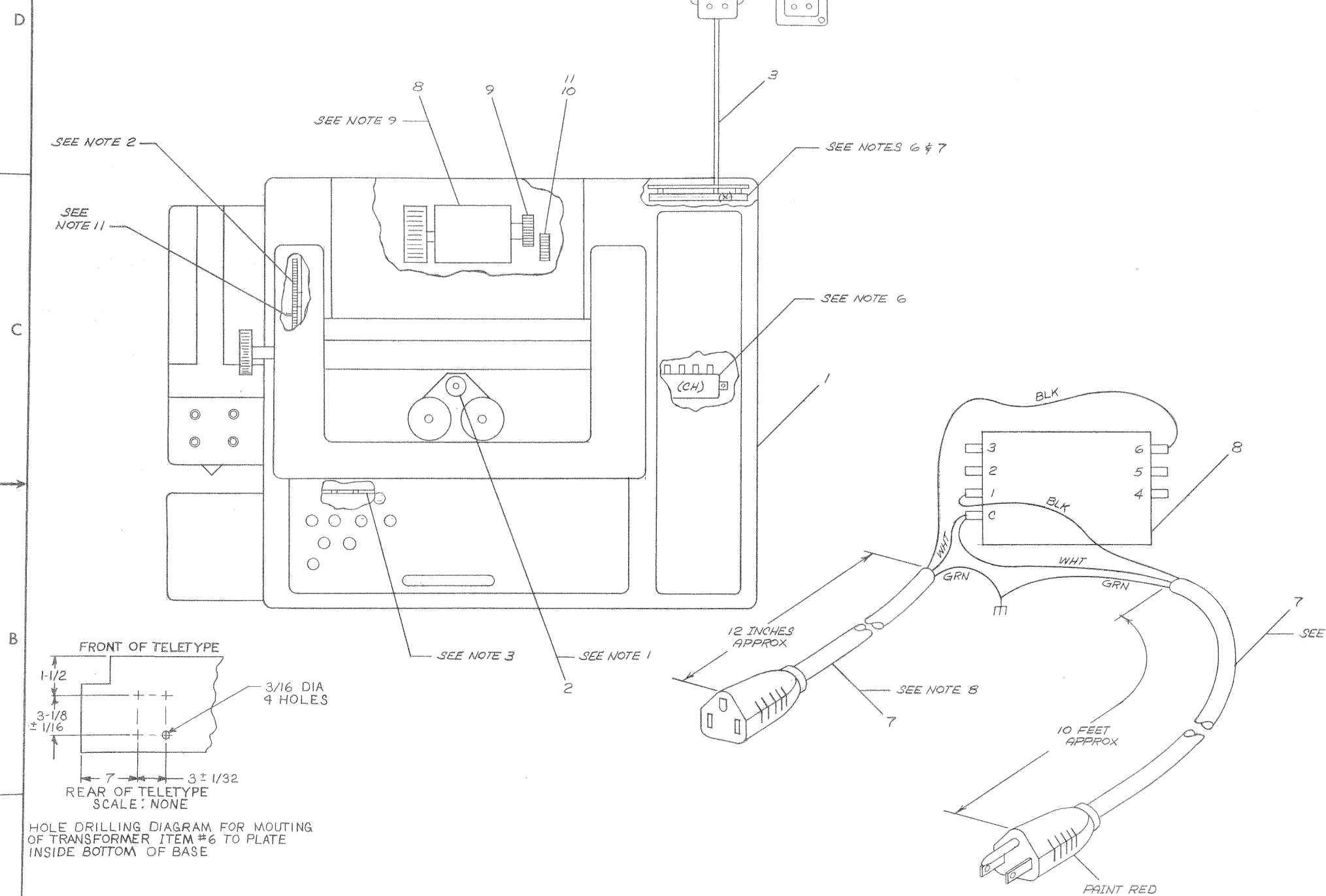

HOLE DRILLING DIAGRAM FOR MOUNTING OF TRANSFORMER ITEM #6 TO PLATE INSIDE BOTTOM OF BASE

REV	CHG	NO.	DATE	BY
A	LT33-00002	7-15-71		A. KENT
B	LT33-00003	10-22-71		Allen Kent 26 July 71
				Allen Kent 28 Oct 71

FIRST USED ON OPTION / MODEL	QTY.	DESCRIPTION	PART NO.	ITEM NO.
PDP10				
PARTS LIST				
UNLESS OTHERWISE SPECIFIED	DRN	DATE	digital EQUIPMENT CORPORATION MAYNARD MASSACHUSETTS	
UNLESS OTHERWISE SPECIFIED	CHK'D	DATE	TITLE	
DIMENSION IN INCHES	ENG.	DATE	TIMESHARING	
TOLERANCES	PROJ. ENG.	DATE	TELETYPE	
DECIMALS FRACTIONS ANGLES	PRDR.	DATE	33 ASR (TY)	
± .005 ± 1/64 ± 0°30'			SIZE/ CODE	NUMBER
FINAL SURFACE QUALITY / REMOVE BURRS AND BREAK SHARP CORNERS			DUA	LT33-B-0
MATERIAL	NEXT HIGHER ASSY		DIST.	
FINISH	SCALE	NONE		
	SHEET	1 OF 1		

This drawing and specifications, herein, are the property of Digital Equipment Corporation and shall not be reproduced or copied or used in whole or in part as the basis for the manufacture or sale of items without written permission.

REV. A  
DUALT33A-0-0

LEGEND	
NUMBER	VARIATION
LT33A-B	50 HZ
LT33A-A	60 HZ

- NOTES
- DO NOT REMOVE "N" PRAWL (WRU)
  - REWIRE FOR FULL DUPLEX 20 MA OPERATION BY:  
A. MOVE P WIRE FROM TERMINAL 8 TO TERMINAL 9 OF THE 151411 TERMINAL STRIP (X).  
B. MOVE W-BL WIRE FROM TERMINAL 4 TO TERMINAL 5 OF THE TERMINAL STRIP.  
C. MOVE BR-Y WIRE FROM TERMINAL 3 TO TERMINAL 5 OF THE TERMINAL STRIP.  
D. MOVE BL WIRE FROM TERMINAL 3 TO TERMINAL 4 OF POWER RESISTOR 181816 (CH).
  - CONNECT WIRES AS FOLLOWS  

SET (X)	COLOR	PLUG 283B-50
3	RED	R
4	GRN	G
6	YEL	Y
7	BLK	B

 ASSEMBLE ONE "BAR-BAND" HOOK TAB INTO HOLE IN 283B BEFORE ASSEMBLING COVER.  
HOOK THE "S" HOOK UNDER ONE OF THE SCREWS BELOW THE TERMINAL BOARD (X) IN THE SET.
  - SUPPLY ITEM 4 LOOSE WITH THE SET.
  - SEE TELETYPE DRAWINGS 6353WD AND 6354WD SUPPLIED WITH SET.
  - ~~SEE 50 HZ OPERATION DRAWING 10-1-71 IN CONNECTION WITH DRAWING 10-1-71-1. PARTS WILL BE SUPPLIED.~~
  - ASSEMBLE ITEM 3 TO SHORT WIRE END OF ITEM 2. ASSEMBLE ITEM 3 COVER WITH MILD STEEL RIGID ON SIDE OF CONDUCTOR WITH RED AND GREEN WIRES.
  - ASSEMBLE LONG WIRE END OF ITEM 2 TO ITEM 1 TERMINAL STRIP (S).
  - ADD TWO 6RS 20 SP4 B4 THYRECTORS DEC #1100106 TO UNIT AND WIRE AS INDICATED BELOW USING ITEM #12. SEE VIEW A-A.
- | FROM          | TO                     |
|---------------|------------------------|
| THYRECTOR * 1 | CONN * 2L OF ON-OFF SW |
| THYRECTOR * 2 | CONN * 2 OF ON-OFF SW  |
| THYRECTOR * 2 | CONN * 1 OF ON-OFF SW  |
10. REFER TO D-IA-7505039-0 FOR MODIFICATION FOR 50 HZ OR 240V OPERATION.

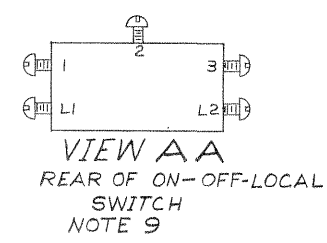
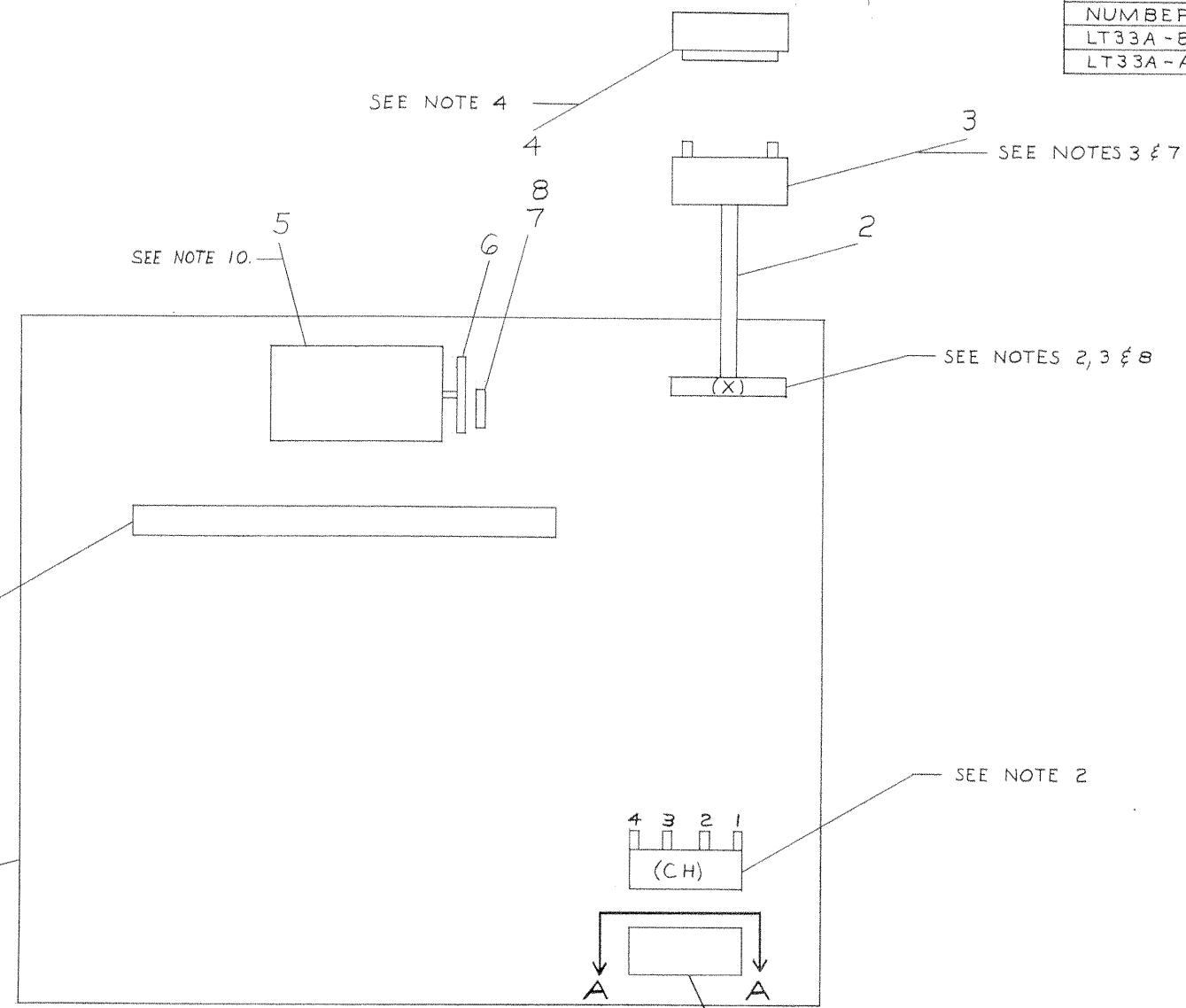

FRONT (TOP VIEW)

REVISIONS	CHANGE NO.	REV.
CHK	LT33-00003	A
CM - Craven	10-21-71	
A. KENT		
Allen Kent	28 Oct 71	

UNLESS OTHERWISE SPECIFIED	
DRN	DATE 1/13/68
CHK'D	DATE 2-1-68
ENG	DATE 25 MAR 68
PROJ. ENG.	DATE 25 MAR 68
PRD	DATE 1/13/68
MATERIAL	++
FINISH	++

QTY.	DESCRIPTION	PART NO.	ITEM NO.
	PARTS LIST		
	digital EQUIPMENT CORPORATION MAYNARD, MASSACHUSETTS		
	TITLE PDP 10 TELETYPE 33KSR		
	SCALE NONE	SIZE CODE DUALT33A-0-0	NUMBER 0-0
	SHEET 1 OF 1	DIST. 16	REV. A

SIZE CODE NUMBER  
DUALT33A-0-0



DIGITAL EQUIPMENT CORPORATION MAYNARD, MASSACHUSETTS			QUANTITY										REVISIONS			
PARTS LIST			LT33A-0-0 50 HZ	LT33A-A-0 40 HZ										CHANGE NO.	DATE	ENG.
ITEM NO.	DWG. NO.	DESCRIPTION														
1		TELETYPE 33TS	1	1												
2	1205693	CORD SET	1	1												
3	1205857-1	TELEPHONE PLUG 283B-50	1	1												
4	1205857-2	TELEPHONE JACK 404B-50	1	1												
5	1204789	MOTOR 182267 50HZ	1													
6	1204850	DRIVE GEAR 181855	1													
7	1204849	PINION GEAR 181851	1													
8	1204848	PINION 181850	1													
9	1609313	ELECT TRANSFORMER 1725	1													
10	9107673-12	LINE CORD 12 FT	1													
11	1100106	GE THYRECTOR 6RS20SP4B4	2	2												
12	9007929	SOLDERLESS CONN #6 AWG 18-22	3	3												
MADE BY R. BERNIER		DATE 1/3/68	TITLE PDP-10 TELETYPE 33TSR					DRWG. NO. A-PL- LT33A-0-0					REV. CTR			
CHECKED D. HEALY		DATE 3/12/68	FOR					ASSY NO PDP-10-33A-0-0					SHEET 1 OF 1			
ENG <i>Alan Kent</i>		DATE 25 MAR 68											A			

This drawing and specifications, herein, are the property of Digital Equipment Corporation and shall not be reproduced or copied or used in whole or in part as the basis for the manufacture or sale of items without written permission.

- NOTES:**
1. ABSTRACTED FROM TELETYPE CORP. 6353 WD ISSUE 20.
  2. THE YEL AND BLK WIRES OF THE TTY LINE CORD SHOULD BE INSULATED WITH A PIECE OF GLASS TAPE (SCOTCH 27) IN HALF DUPLEX SERVICE.
  3. L RELAY IS PICKED UP IN LINE, DROPPED OUT IN OFF AND LOCAL.
    - X CLOSED WHEN PICKED UP
    - + CLOSED WHEN DROPPED OUT.
  4. WITHOUT AUTO MOTOR CONTROL
    - ① 60 MA
    - ② 20 MA
    - ③ HALF DUPLEX
    - ④ FULL DUPLEX

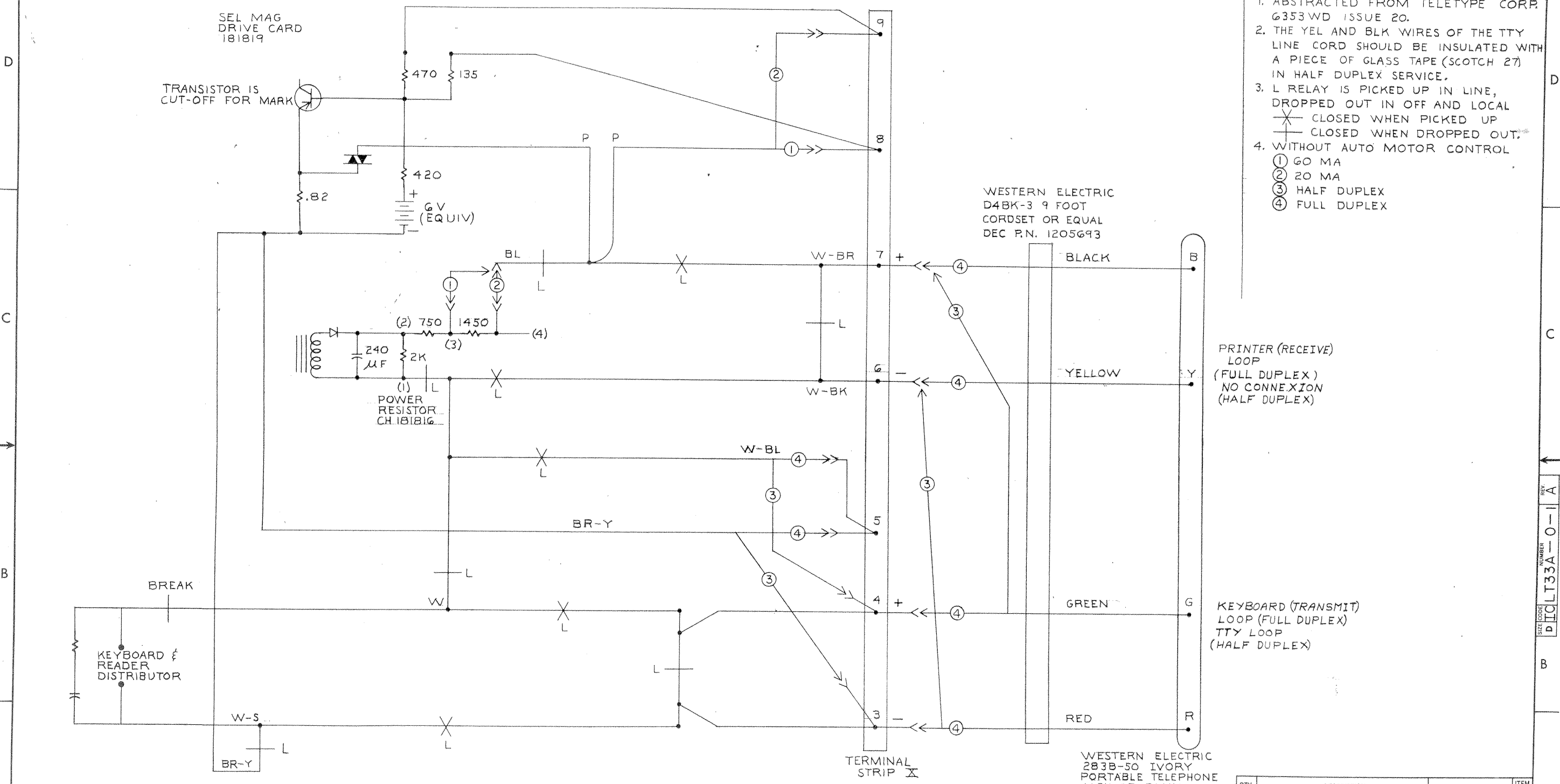

WESTERN ELECTRIC  
D4BK-3 9 FOOT  
CORDSET OR EQUAL  
DEC P.N. 1205693

PRINTER (RECEIVE)  
LOOP  
(FULL DUPLEX)  
NO CONNECTION  
(HALF DUPLEX)

KEYBOARD (TRANSMIT)  
LOOP (FULL DUPLEX)  
TTY LOOP  
(HALF DUPLEX)

WESTERN ELECTRIC  
283B-50 IVORY  
PORTABLE TELEPHONE  
JACK OR EQUAL  
DEC P.N. 1205857-1

REV.	NO.	DATE
A	1	28 Oct 67

CHG  
CM-G  
A-KENT  
Allen, Kent

SIZE CODE  
NUMBER  
DUALT33A-0-11 A

UNLESS OTHERWISE SPECIFIED		PARTS LIST	
DRY	DATE 2/27/68	DRY	DATE 2/27/68
CHK'D	DATE 3/14/68	CHK'D	DATE 3/14/68
ENG.	DATE 25 MAR 68	ENG.	DATE 25 MAR 68
PROJ. ENG.	DATE 25 MAR 68	PROJ. ENG.	DATE 25 MAR 68
PROD.	DATE 17 APR 68	PROD.	DATE 17 APR 68
TOLERANCES DECIMALS FRACTIONS ANGLES = .005 = 1/64 = 0°30'		TITLE <b>PDP 10 TELETYPE MODEL 33KSR</b>	
MATERIAL		FIRST USED ON D-UA-LT33A-0-0	
FINISH		SCALE	
		SHEET 1 OF 1	
		DISTRIBUTION DIST. G	