

XEROX

THIS MANUAL INTENDED FOR USE WITH DIABLO SERIES 1300 HY TYPE II
PRINTER PARTS CATALOG, PUBLICATION No. 82404-XX

Diablo Systems Incorporated
A Xerox Company

Series 1600 Hyterm Terminal
Models 1610/1620
Parts Catalog

PREFACE

This manual is intended for use with Diablo Series 1300 HyType II Printer Parts Catalog. Publication No. 82404-XX.

The contents of this catalog represents the unit as manufactured at the time of publication. All parts listed are shown in the correct form for ordering, including those assemblies which are supplied as single parts. Items not listed are NOT FIELD REPLACEABLE. Such items are sometimes included for completeness of illustration only.

Diablo Systems, Inc. reserves the right to make changes in its products without incurring obligations to incorporate such changes in previously manufactured units.

Parts orders should be addressed to your Diablo Sales Representative.

Comments on this catalog, or its use, are invited. Please address all comments to:

Customer Service Publications
Diablo Systems, Inc.
3190 Corporate Place, I-109
Hayward, CA 94545

"Diablo" and "HyType" are trademarks of Xerox Corporation.

"Xerox" is a trademark of Xerox Corporation.

Publication No. 82334-02 - Second Edition

Previous Editions:
First - December, 1976

Table of Contents

	<u>Page</u>
Section I - Mechanical Assemblies	
I.1a	23XXX-XX Final Assembly 1-1
I.1b	23XXX-XX Final Assembly (Continued) 1-5
I.2a	23708 Control Panel Assembly 1-7
I.2b	23710 Control Panel Assembly 1-9
Section II - PCB Assemblies	
II.1	23702-XX HPR01 PCB Assembly 2-1
II.2	23704-XX HPR02 PCB Assembly 2-3
II.3	23942-XX HCURL PCB Assembly 2-4
Section III - Cable Assemblies	
III.1	23898/23899 AC Harness Assemblies 3-1
III.2	23731 Keyboard Cable Assembly 3-3
III.3	23730-01/23939-01 EIA Cable Assemblies 3-5
III.4	400017-01 Current Loop Cable Assembly 3-7
III.5	23838 DC Power Cable Assembly 3-9
III.6	26097-01 DC Power Cable Assembly 3-11
Appendices	
Appendix 'A'	Final Assembly Configurations A-1
Appendix 'B'	Color Options A-2
Appendix 'C'	Keyboard Options A-2
Appendix 'D'	Accessories A-3

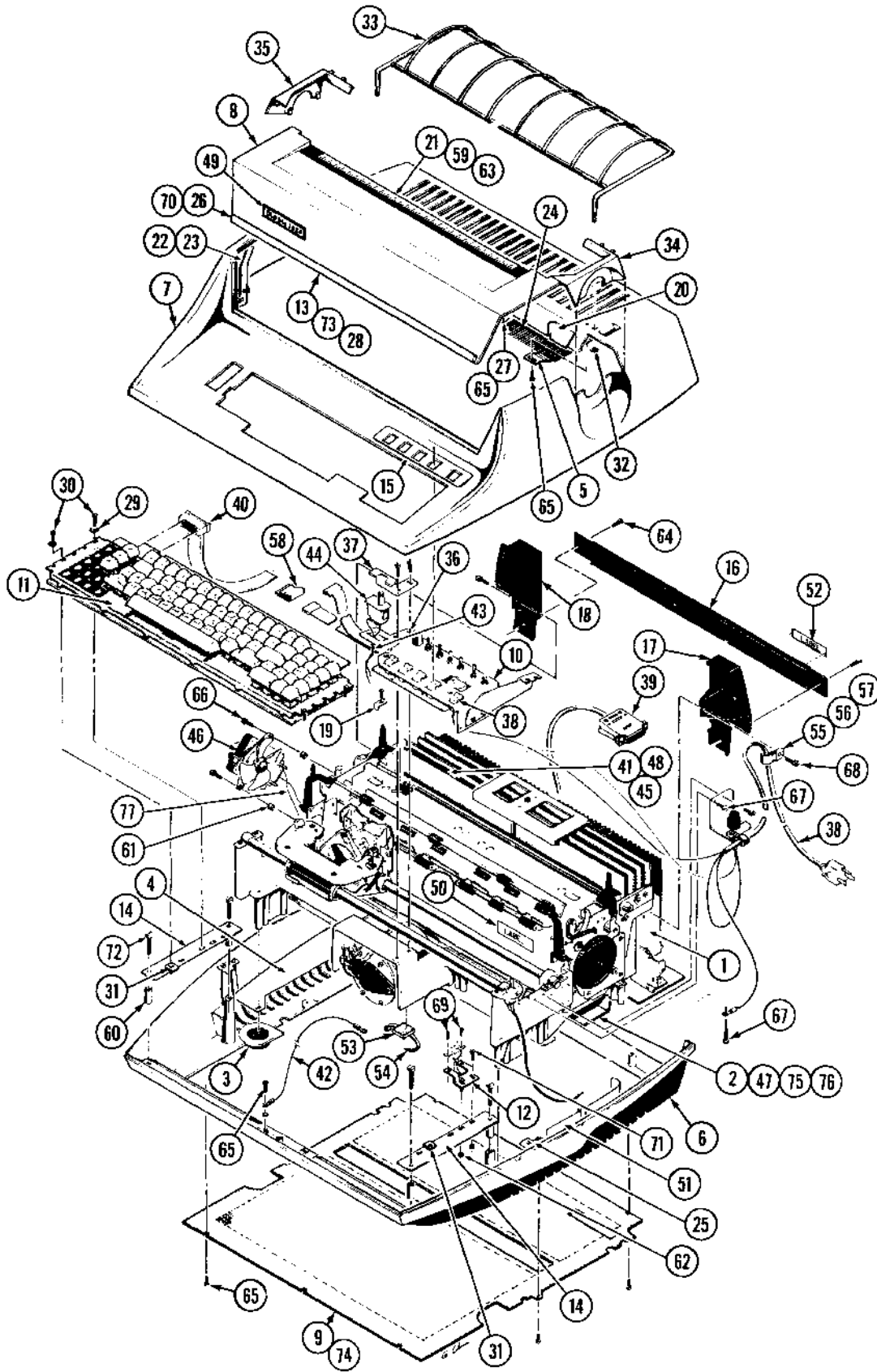

Figure 1-la
23XXX-XX FINAL ASSEMBLY

SECTION I.1a

23XXX-XX FINAL ASSEMBLY
(see notes)

ITEM	PART NO.	DESCRIPTION	ITEM	PART NO.	DESCRIPTION
1	24000-02	Printer Assembly, HyType II (Note 2)	38	23898 23899	AC Power Cable, 115VAC AC Power Cable, 230VAC
2	26021-01 26021-02	Power Supply, 115VAC Power Supply, 230VAC	39	23730-01 23939-01	EIA Cable, Standard EIA Cable, Foxboro
3	23965-01	Front Barrier, KSR	40	23731	Cable, Keyboard
4	400206-01	Side Barrier	41	23702-XX 23704-XX	HPR01 PCB Assembly HPR02 PCB Assembly (see Sections II.1 & II.2)
5	23976-01	Clip, Screen Mounting	42	23831-10 23831-17	Wire, #16, R/O Wire, #16, KSR
6	400012-XX	Bottom Cover, KSR (Note 3)	43	23855	Cable Assembly, Cover Open Switch
7	23875-XX 23874-XX	Top Cover, KSR, with 10-Key Pad (Note 3) Top Cover, KSR, w/o 10-Key Pad (Note 3)	44	10961	Switch, Cover Open
8	23244-XX	Access Cover (Note 3)	45	23942-XX	HCURL PCB Assembly (see Section II.3)
9	24392-01	Bottom Pan, KSR (Note 4)	46	14011-01 14012-01	Fan, 115VAC Fan, 230VAC
10	23710	Control Panel Assembly (see Section I.2)	47	26097-01 23838	Cable, DC Power (Quick Disconnect Terminals) Cable, DC Power (Winchester Type Plug) (see Section III.5 & III.6)
11	23XXX-XX	Keyboard Assembly (Note 5)	48	400017-01	Cable, Current Loop
12	23863	Bracket, Power Switch, KSR	49	400502-01	Nameplate, 1620
13	301150-01	Actuator, Cover Open Switch	50	400102-01 400102-02	Label, Serial Number, 115VAC Label, Serial Number, 230VAC
14	23867	Bracket, Keyboard	51	23147-02	Label, Warning
15	23716	Overlay, Control Panel	52	14035-05	Label, 230V
16	24472	Cover Strip, Rear	53	10752-01	Anchor, Cable Tie
17	24474-01	Cover, Rear, Right	54	10538-01	Cable Tie
18	24474-02	Cover, Rear, Left	55	10535-12	Cable Clamp, .250 I.D.
19	400431-01	Defeat Clip, Paper Out Switch	56	10537	'D' Washer
20	22904-01	Guide, Paper	57	10535-18	Cable Clamp, .312 I.D.
21	22932	Scale, Paper	58	10924	Cable Clamp, Flat Cable
22	46042-01	Latch, Right	59	70659-02	Retaining Ring
23	46042-02	Latch, Left	60	71234-14	Spacer
24	26119-01	Screen, Top Cover Vent	61	20460	Spacer
25	20667	Stop, Latch	62	70701-06	Keypnut, 6-32
26	20780	Handle	63	70413-02	Fastener, Washer
27	40844-02	Clip, Access Cover	64	70805-02	Screw, 4-20 X .375 T.F.
28	70169-04	Flatwasher, #4	65	71236-04	Screw, 6-32 X .250 T.F.
29	70737-06	Lockwasher, #6	66	70829-10	Screw, 8-32 X .625 T.F.
30	70691	Screw, 6-32 Sheet Metal	67	70829-06	Screw, 8-32 X .375 T.F.
31	70702-24	Nut, 'U' Clip	68	70829-08	Screw, 8-32 X .500 T.F.
32	70170-08	Retaining Ring	69	70027-04	Screw, 2-56 X .250 P.H.
33	40696	Rack, Cover			
34	23847-XX	Skirt, Right (Note 3)			
35	23848-XX	Skirt, Left (Note 3)			
36	23866	Bracket, Cover Open Switch			
37	23854	Guard, Switch			

ITEM	PART NO.	DESCRIPTION
70	70029-05	Screw, 4-40 X .312 P.H.
71	70030-08	Screw, 6-32 X .500 P.H.
72	70829-20	Screw, 8-32 X 1.250 T.F.
73	70029-06	Screw, 4-40 X .375 P.H.
74	23147-05	Label, Warning
75	400478-01	Screen
76	70828-06	Screw, 6-32 X .375 T.F.
77	23856	Cable, Fan

Notes:

- (1) For Final Assembly Configurations, see Appendix 'A'.
- (2) For Printer Parts, see Publication No. 82404-XX.
- (3) For Cover Color Configurations, see Appendix 'B'.
- (4) For Bottom Feed, use 24392-03.
- (5) For Keyboard Assemblies, see Appendix 'C'.

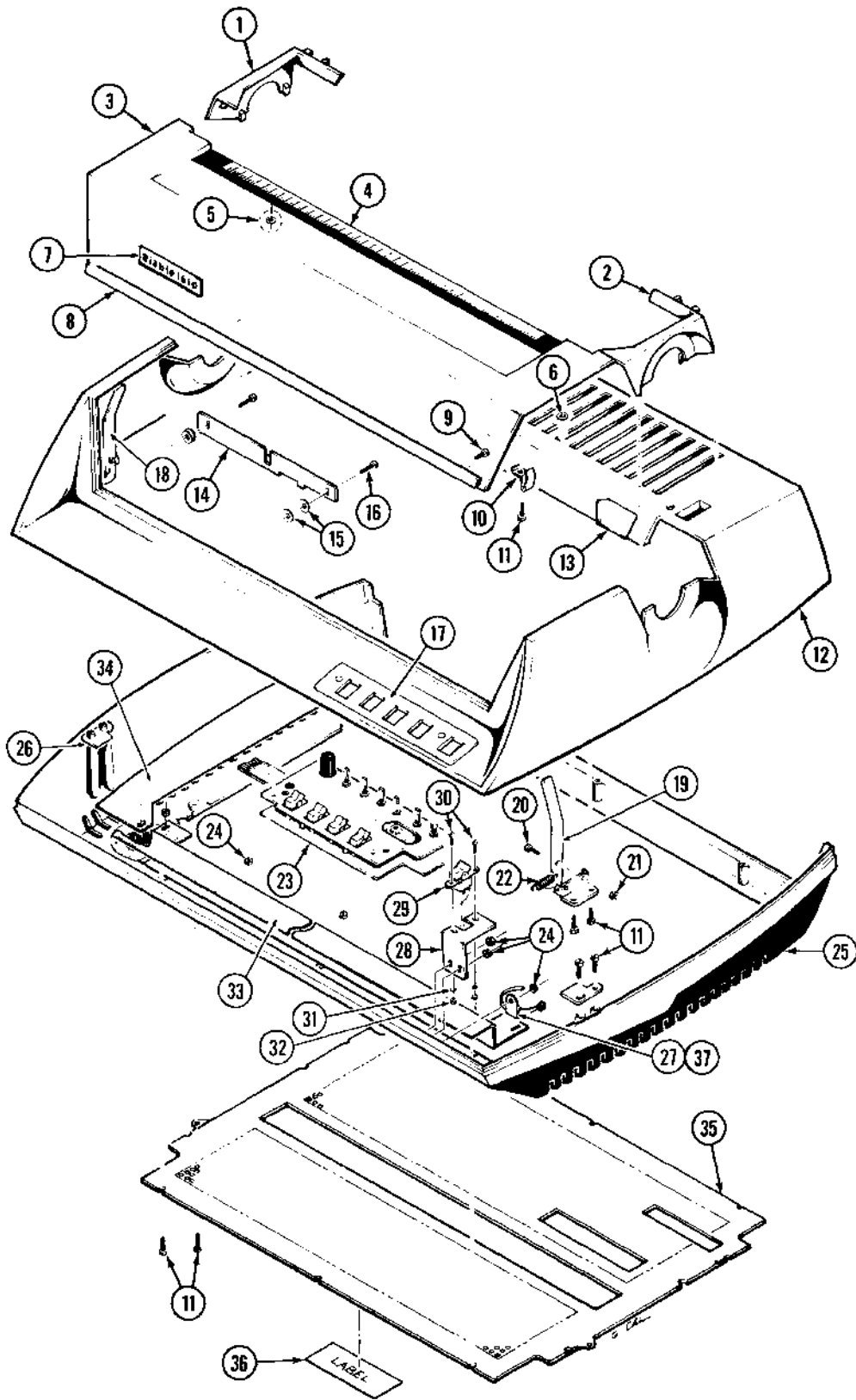

Figure 1-1b
23XXX-XX FINAL ASSEMBLY

SECTION I.1b

23XXX-XX FINAL ASSEMBLY (Continued)
(see notes)

ITEM	PART NO.	DESCRIPTION	Notes:
1	23848-XX	Skirt, Left (Note 2)	
2	23847-XX	Skirt, Right (Note 2)	(1) For Final Assembly Configurations, see Appendix 'A'.
3	23244-XX	Access Cover (Note 2)	
4	22932	Scale, Paper	(2) For Cover Color Configurations, see Appendix 'B'.
5	70659-02	Retaining Ring	
6	70413-02	Fastener, Washer	(3) For Bottom Feed, use 24391-03.
7	400501-01	Nameplate, 1610	(4) Items 20 and 21 replaced by a rivet on later units.
8	20780	Handle	
9	70029-05	Screw, 4-40 X .312 P.H.	
10	40844-02	Clip, Access Cover	
11	71236-04	Screw, 6-32 X .250 T.F.	
12	23717-XX	Top Cover, R/O (Note 2)	
13	22904-01	Guide, Paper	
14	301150-01	Actuator, Cover Open Switch	
15	70169-04	Flatwasher, #4	
16	70029-06	Screw, 4-40 X .375 P.H.	
17	23716	Overlay, Control Panel	
18	46042-02	Latch, Left	
19	46042-01	Latch, Right	
20	20668	Pivot Screw (Note 4)	
21	70167-06	Nut, 6-32 Hex (Note 4)	
22	20295	Spring	
23	23710	Control Panel Assembly (see Section I.2)	
24	70701-06	Keqnut, 6-32	
25	23721-XX	Bottom Cover, R/O (Note 2)	
26	20667	Stop, Latch	
27	10538-01	Cable Tie	
28	23864	Bracket, Power Switch, R/O	
29	42644-03	Rocker Switch, DPDT	
30	70027-04	Screw, 2-56 X .250 P.H.	
31	70168-02	Lockwasher, #2	
32	70166-02	Nut, 2-56 Hex	
33	23966	Front Barrier, R/O	
34	400206-01	Side Barrier	
35	24391-01	Bottom Pan, R/O (Note 3)	
36	23147-05	Label, Warning	
37	10972	Anchor, Cable Tie	

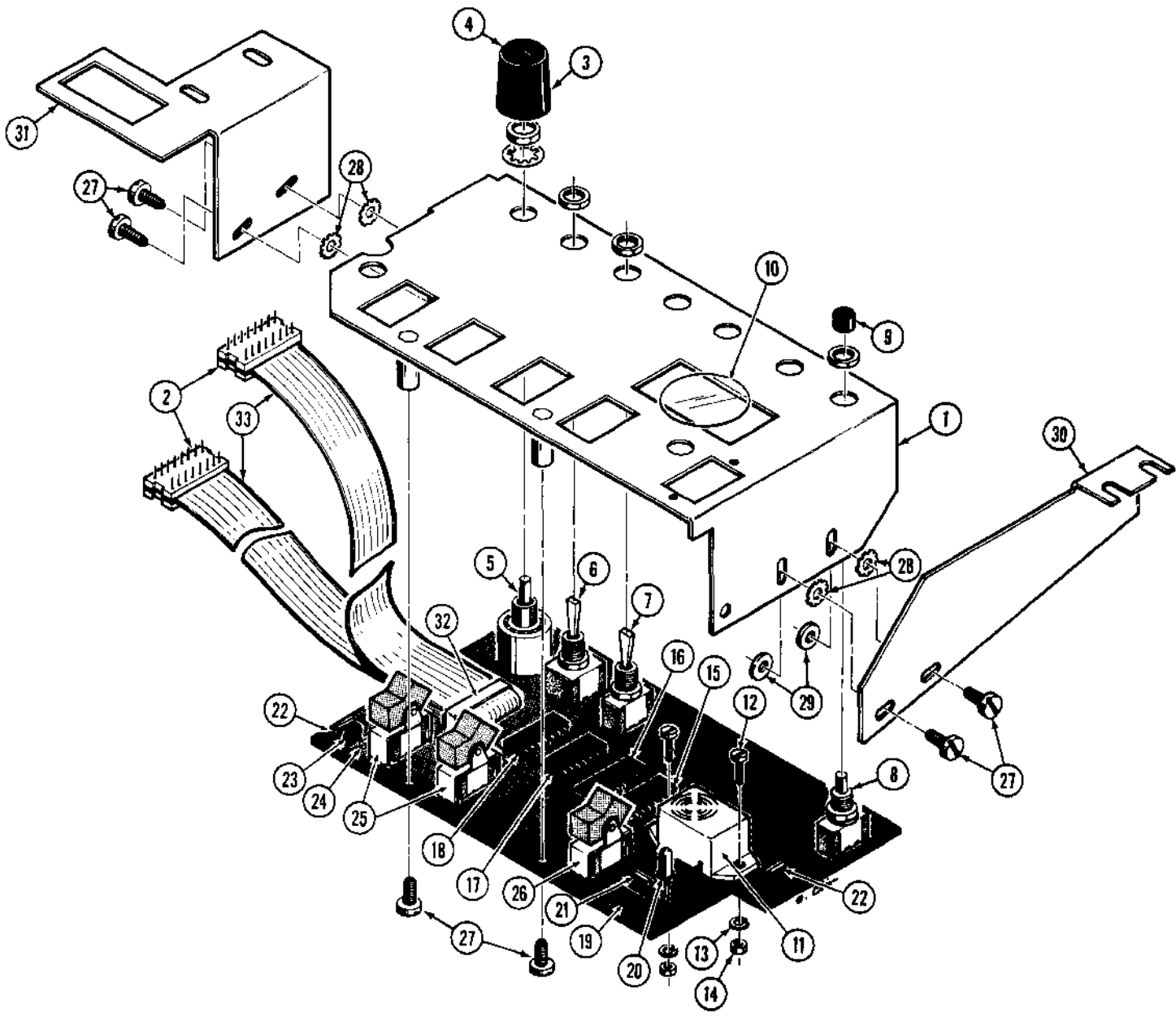

Figure 1-2a
23780 CONTROL PANEL ASSEMBLY

SECTION I.2a

23708 CONTROL PANEL ASSEMBLY
(early version)
(see notes)

<u>ITEM</u>	<u>PART NO.</u>	<u>DESCRIPTION</u>
1	23852	Control Panel
2	10586-01	Connector, Flat Cable, 16-Pin
3	14000-01	Knob (use with #14001-01)
	14002-01	Knob (use with #14003-01)
4	14001-01	Knob Cap
	14003-01	Knob Cap
5	42510-01	Rotary Switch, 12-Position
6	10811	Toggle Switch, DPDT
7	10809	Toggle Switch, SPDT
8	10895-01	Pushbutton Switch
9	10965-02	Cap, Switch, Red
10	23086	Cover, Buzzer
11	42503-01	Buzzer
12	70027-06	Screw, P.H., 2-56 X .375"
13	70168-02	Lockwasher, #2
14	70166-02	Hex Nut, 2-56
15	10319	IC, 74H21
16	10394	IC, 74148
17	10119	IC, 7408
18	10761	IC, Resistor Network, 1K
19	10181	IC, 75451
20	14005-01	LED
21	10160	Diode, 1N4454
22	10022-15	Resistor, 150 Ohm 1/4W 5%
23	42077-01	Capacitor, 1uF 12V
24	10410-22	Capacitor, 22uF 15V
25	42502-10	Rocker Switch, SPDT, Momentary
26	42501-10	Rocker Switch, SPDT
27	70030-04	Screw, P.H., 6-32 X .250"
28	70737-06	Lockwasher, #6
29	23849	Nut Plate
30	23853	Bracket, Right
31	23843	Bracket, Left
32	42500-02	Clip, Strain Relief
33	10588-04	Cable, Flat, 16-Conductor

Notes:

- (1) Control Panel Assembly 23708 no longer available, use 23710 and new Top Cover with mounting studs.

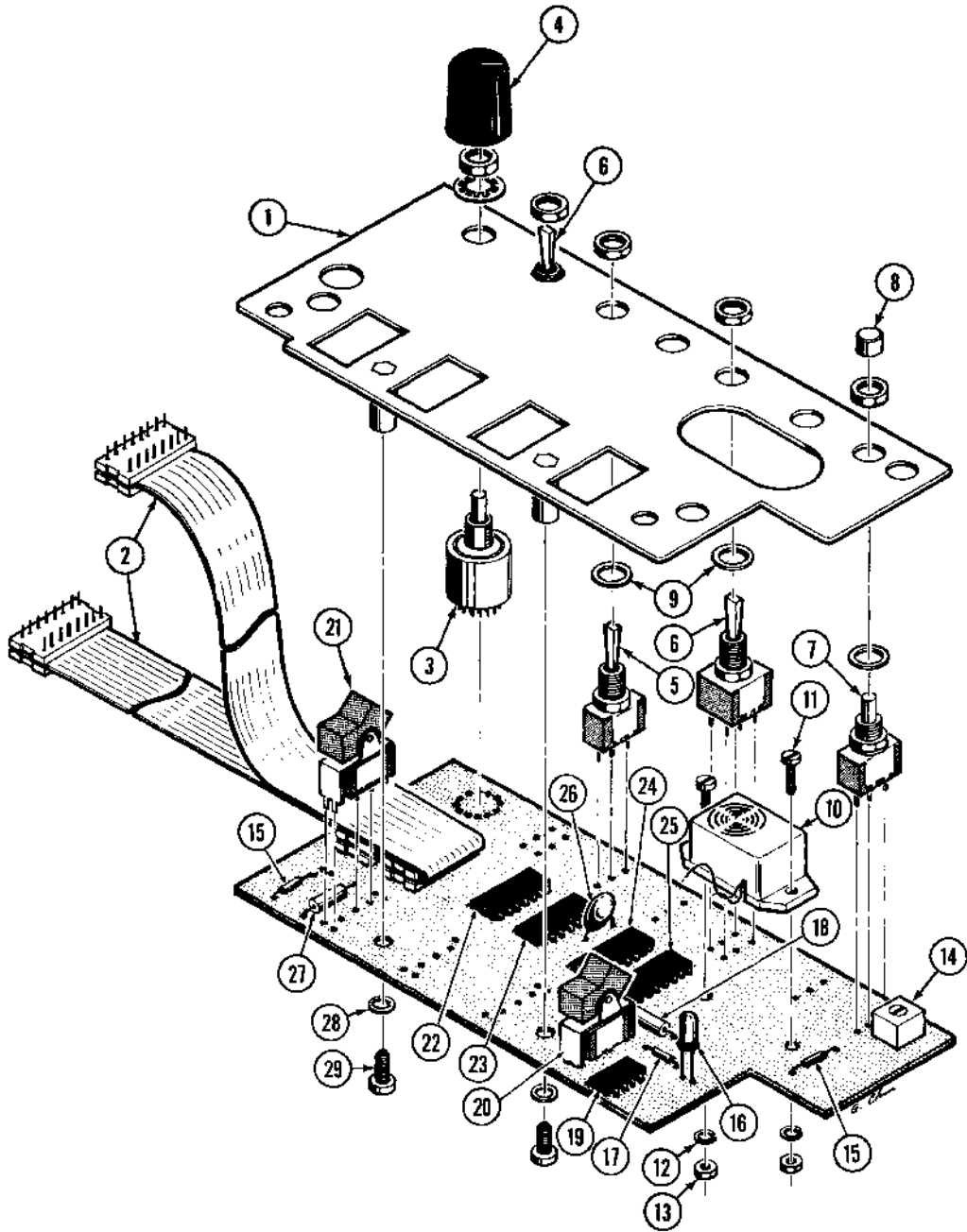

Figure 1-2b
23710 CONTROL PANEL ASSEMBLY

SECTION I.2b

23710 CONTROL PANEL ASSEMBLY
(Later Version)

<u>ITEM</u>	<u>PART NO.</u>	<u>DESCRIPTION</u>
1	23861	Control Panel
2	400683-01	Cable Assembly
3	42510-01	Switch, Rotary, 12-Position
4	14024-01	Knob
5	10809	Switch, Toggle, SPDT
6	10811	Switch, Toggle, DPDT
7	10895-01	Switch, Pushbutton
8	10965-02	Cap, Red
9	400103-01	Spacer Nylon
10	42503-01	Buzzer
11	70027-06	Screw, P.H., 2-56 X .375"
12	70168-02	Lockwasher, #2
13	70166-02	Hex Nut, 2-56
14	10224-10	Pot, 1K 1/2W 10%
15	10022-15	Resistor, 150 Ohm 1/4W 5%
16	14005-01	Lamp, LED
17	10160	Diode, 1N4454
18	10077-22	Capacitor, 22uF 35V
19	10181	IC, 75451
20	42501-10	Switch, Rocker, SPDT
21	42502-10	Switch, Rocker, SPDT, Momentary
22	10761	IC, Resistor Network, 1K
23	10119	IC, 7408
24	10394	IC, 74148
25	10319	IC, 74H21
26	42077-01	Capacitor, .1uF 12V
27	10410-22	Capacitor, 22uF 15V
28	70425-06	Lockwasher, #6
29	70030-04	Screw, P.H., 6-32 X .250"

SECTION II.1

23702-xx HPR01 PCB ASSEMBLY
(see notes)

<u>PART NO.</u>	<u>DESCRIPTION</u>	<u>LOCATION(S)</u>	<u>PART NO.</u>	<u>DESCRIPTION</u>	<u>LOCATION(S)</u>
	<u>RESISTORS</u>		10761	Resistor Network, 1K	A9,E22
10023-10	1K 1/4W 5%	A10,A11,A12 A13,A14,A15 A16,A17,A18 A19,A21,A23 F54		<u>MISCELLANEOUS</u>	
10024-10	10K 1/4W 5%	F17	42525-01	Heatsink, Finned, TO-5	A58
10024-13	13K 1/4W 5%	A68,B21,B72 D6, D7, D21 D72,E58	42526-01	Heatsink, Finned	A50
	<u>CAPACITORS</u>		70515-05	Screw, P.H., 4-40 X .312"	A48
42077-01	.1uF 12V	A4, A22,A35 A49,A73, B4 B19,B39,B58 B73, D4,D19 D32,D41,D59 D60,E45,E47 E57,E60,E74 E75,F25,F57 F74	70701-04	Kepnut, 4-40	A48
10086-10	.1uF 50V	A47,B57,D73 E73,F36,F73	10899-24	Socket, IC, 24-Pin	D62,E62
10076-10	1uF 35V	B59,B61	10899-40	Socket, IC, 40-Pin	F37
10077-22	22uF 35V	A36,A64	10760	Socket, DIP, 16-Pin	J2
10061-10	10pF 500V	F26	10596-01	Socket, IC, 16-Pin	J3
10493-68	6.8uF 35V	F35	10910-06	Connector, 12-Pin	J1
10410-22	22uF 15V	A30,A66	10564-26	Jumper Wire, #26	F3
	<u>I.C.'s</u>		10634	Plug, Shorting (1200 Baud Option)	F23
10136	7404	A50	10592	Jack, Closed Entry	F23
10302	7432	D34	10255-03	Crystal, 18MHz, HC-18/u	F27
10139	7474	A8	23735	EROM, HyTerm 1 (Note 2)	D62
10356	74163	B33,D33	23738	EROM, HyTerm 1 (Note 3)	D62
10353	75150P	B43,B51	26051	EROM, HyTerm 1 (Note 4)	D62
10354	75154	E7	26053	EROM, HyTerm 1 (Note 5)	D62
42338	8080A	F37	26055	EROM, HyTerm 1 (Note 6)	D62
42334-11	1024-Bit RAM	A65,B65	26057	EROM, HyTerm 1 (Note 7)	D62
42335-02	8205	E36,E49	26072	EROM, HyTerm 1 (Note 8)	D62
42337-02	8212	A20,A34, B5 B20,D5, D20	26080-01	EROM, HyTerm 1 (Note 9)	D62
10215-03	8224	F27	26198-01	EROM, HyTerm 1 (Note 10)	D62
42331	8228	F60	400140-01	EROM, HyTerm 1 (Note 11)	D62
42336	8251	D45	400192-01	EROM, HyTerm 1 (Note 12)	D62
42155-05	LM320H-5.0	A59	23734	EROM, HyTerm 0 (Note 13)	E62
42155-12	LM320H-12	A58	26201	EROM, HyTerm 0 (Note 14)	E62
42154-12	LM341P-12	A41	26079-01	EROM, HyTerm 0 (Note 15)	E62
			26197-01	EROM, HyTerm 0 (Note 16)	E62
			Notes:		
			(1) HPR01 PCB Assemblies:		
			23702-01 TW Paired Keyboard		
			23702-02 Bit Paired Keyboard		
			23702-03 Scandinavian Keyboard		
			23702-04 Norsk Keyboard		
			23702-05 German Keyboard		
			23702-06 French Qwerty Keyboard		
			23702-07 French Azerty Keyboard		
			23702-08 Foxboro TW Paired Keyboard		
			23702-09 Raytheon TW Paired Keyboard		
			23702-10 French Azerty Keyboard, IBM Format		

Notes: (Con't)

23702-11 APL Europe Keyboard
23702-99 Basic assembly w/o EROM's or
optional jumpers.

- (2) Used on 23702-01 assembly only.
- (3) Used on 23702-02 assembly only.
- (4) Used on 23702-03 assembly only.
- (5) Used on 23702-04 assembly only.
- (6) Used on 23702-05 assembly only.
- (7) Used on 23702-06 assembly only.
- (8) Used on 23702-07 assembly only.
- (9) Used on 23702-08 assembly only.
- (10) Used on 23702-09 assembly only.
- (11) Used on 23702-10 assembly only.
- (12) Used on 23702-11 assembly only.
- (13) Used on 23702-01,-02,-06,-07,-10,-11
assemblies only.
- (14) Used on 23702-03,-04,-05 assemblies only.
- (15) Used on 23702-08 assembly only.
- (16) Used on 23702-09 assembly only.
- (17) Thermal Compound, 10549, required when
replacing component at A41.

SECTION II.2

23704-XX HPR02 PCB ASSEMBLY
(see notes)

<u>PART NO.</u>	<u>DESCRIPTION</u>	<u>LOCATION(S)</u>	<u>PART NO.</u>	<u>DESCRIPTION</u>	<u>LOCATION(S)</u>
	<u>RESISTORS</u>			<u>MISCELLANEOUS</u>	
10023-10	1K 1/4W 5%	B67,E15,E18 E19,E62,E66 F10,F11,F13 F14,F15,F16 F28	10589-03	Washer, Fiber, #4	E72
			10508-05	Screw, P.H., 4-40 X .312"	E72
10024-10	10K 1/4W 5%	D67	70701-04	Keypnut, 4-40	E72
10024-13	13K 1/4W 5%	A75,B47, D3 D19,E6, E34 F29,F30	10899-24	Socket, IC, 24-Pin	A22
			10899-40	Socket, IC, 40-Pin	A37
			10760	Socket, IC, 16-Pin	J2
			10596-01	Socket, IC, 16-Pin	J3
			10910-06	Connector, 12-Pin	J1
			10564-26	Jumper Wire, #26	A4
			10592	Jack, Closed Entry	B2
			10634	Plug, Shorting (1200 Baud Option)	B2
			10255-03	Crystal, 18MHz, HC-18/u	B73
	<u>CAPACITORS</u>		23695	MASK ROM, HyTerm 1 (Note 2)	A22
42077-01	.1uF 12V	A35,A59,A74 B4, B20,B44 B45,D4, D20 D35,D46,D57 D59,D71,E2 E20,E21,E35 E56,E58,E59	23696	MASK ROM, HyTerm 1 (Note 3)	A22
10086-10	.1uF 50V	A58,D72,E65 D36	400036-01	MASK ROM, HyTerm 1 (Note 4)	A22
10076-10	1uF 35V	B41,E68	400038-01	MASK ROM, HyTerm 1 (Note 5)	A22
10077-22	22uF 35V	F36,F62	400108-01	MASK ROM, HyTerm 1 (Note 6)	A22
10493-68	6.8uF 35V	D63			
10410-22	22uF 15V	F32,F63			
10061-10	10pF 500V	D70			
	<u>I.C.'s</u>				
10136	7404	E49			
10302	7432	E60			
10139	7474	E8			
10356	74163	D38,D50			
10353	75150P	B62,D65			
10354	75154	B6			
42338	8080A	A37			
42334-11	1024-Bit RAM	B48,D48			
42335-02	8205	E50			
42337-04	8212	B5, B21, D5 D37,E22,E36			
10215-04	8224	D60			
42331	8228	A60			
42336	8251	D21			
42155-05	LM320H-5.0	F53			
42155-12	LM320H-12	F60			
42154-12	LM341P-12	E72			
10761	Resistor Network, 1K	B37,E7			

Notes:

- (1) HPR02 PCB Assemblies:
23704-01 - TW Paired Keyboard
23704-02 - Bit Paired Keyboard
23704-03 - Scandinavian Keyboard
23704-06 - French Qwerty Keyboard
23704-09 - Raythoen TW Paired Keyboard
23704-99 - Basic assembly w/o EROM's or
optional jumpers
- (2) Used on 23704-01 assembly only.
- (3) Used on 23704-02 assembly only.
- (4) Used on 23704-03 assembly only.
- (5) Used on 23704-06 assembly only.
- (6) Used on 23704-09 assembly only.

SECTION II.3

23942-XX HCURL PCB ASSEMBLY
(see notes)

<u>PART NO.</u>	<u>DESCRIPTION</u>	<u>LOCATION(S)</u>
<u>RESISTORS</u>		
10021-82	82 Ohm 1/4W 5%	D57,D69,E59 E71
10026-10	1M 1/4W 5%	E24,E57,E70
10025-10	100K 1/4W 5%	D51,D64
10023-10	1K 1/4W 5%	A13,D60
10022-39	390 Ohm 1/4W 5%	D24
10032-62	620 Ohm 1/4W 5% or	E32,E48
10032-20	200 Ohm 1/4W 5%	
<u>CAPACITORS</u>		
42077-01	.1uF 12V	E15,E22,E41
10086-10	.1uF 50V	B50,B52
10076-10	1uF 35V	F58
10077-22	22uF 35V	F34,F65
10410-22	22uF 15V	F35,F67
<u>TRANSISTORS</u>		
42220-01	2N2219A	D59,D71
<u>I.C.'s</u>		
10136	7404	E38
13145	7405	E45
10299-01	7414	E21
10353	75150P	D55
10354	75154	E13
42168-01	Opto Coupler	D56,D68,E28 E56,E68
42155-12	LM320H-12	F59
42154-12	LM341P-12	F44
<u>MISCELLANEOUS</u>		
10508-05	Screw, 4-40 X .312 P.H.	F35
70701-04	Keypnut, 4-40	F35
10589-03	Washer, #4 Fiber	F35
10910-07	Connector, 14-Pin Right Angle	J1
10564-26	Jumper Wire, #26 Solid	A50

Notes:

(1) HCURL PCB Assemblies:

- 23942-01 - Passive Half Duplex
- 23942-02 - 20mA Active Full Duplex
- 23942-03 - 20mA Active Half Duplex
- 23942-04 - 60mA Active Full Duplex
- 23942-05 - 60mA Active Half Duplex
- 23942-99 - Basic assembly w/o jumpers or current source resistors.

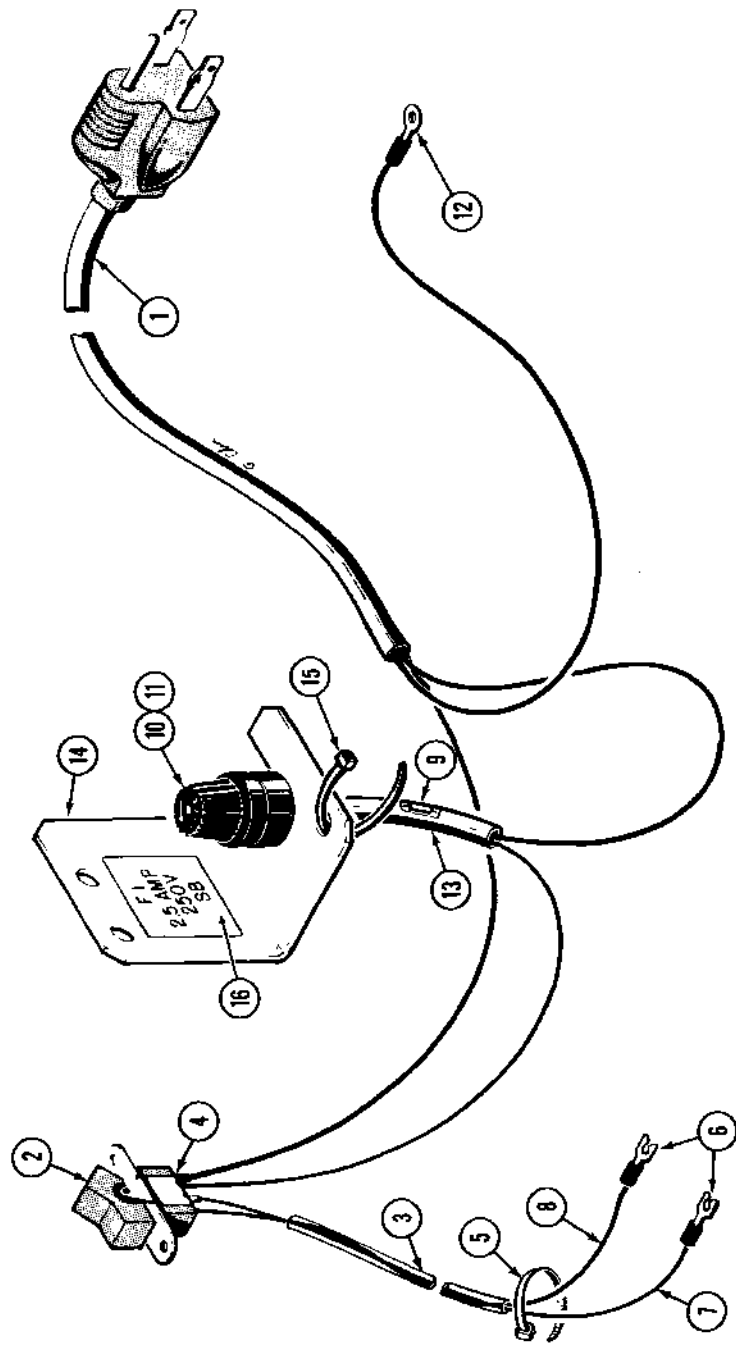

Figure 3-1
 23898 AC HARNESS ASSEMBLY, 115VAC
 23899 AC HARNESS ASSEMBLY, 230VAC

SECTION III.1

23898 AC HARNESS ASSEMBLY, 115VAC
 23899 AC HARNESS ASSEMBLY, 230VAC

<u>ITEM</u>	<u>PART NO.</u>	<u>DESCRIPTION</u>
1	14009-12	AC Power Cable, #18, 3-Conductor (Note 1)
	10974	AC Power Cable, #18, 3-Conductor (Note 2)
2	42644-03	Rocker Switch, DPDT
3	10973-21	Tubing, Clear Vinyl, #6
4	10567-24	Tubing, Heatshrink, .125 Dia.
5	10884-03	Cable Tie
6	10969-14	Spade Lug, #6
7	10952-09	Wire, #18, White, 300V (Note 1)
	10957-06	Wire, #18, Blue, 600V (Note 2)
8	10952-00	Wire, #18, Black, 300V (Note 1)
	10957-01	Wire, #18, Brown, 600V (Note 2)
9	10567-36	Tubing, Heatshrink, .250 Dia.
10	10705	Fuse Holder
11	10717-05	Fuse, 5A SB (Note 1)
	10962-10	Fuse, 2.5A SB (Note 2)
12	10616-08	Ring Lug, #8
13	10567-43	Tubing, Heatshrink, .500 Dia.
14	23833	Bracket, Fuse
15	10967-02	Cable Tie
16	23846	Label, 2.5A Fuse (Notes 2 & 3)

Notes:

- (1) Used on 23898 assembly only.
- (2) Used on 23899 assembly only.
- (3) 5A label part of fuse bracket 23833.

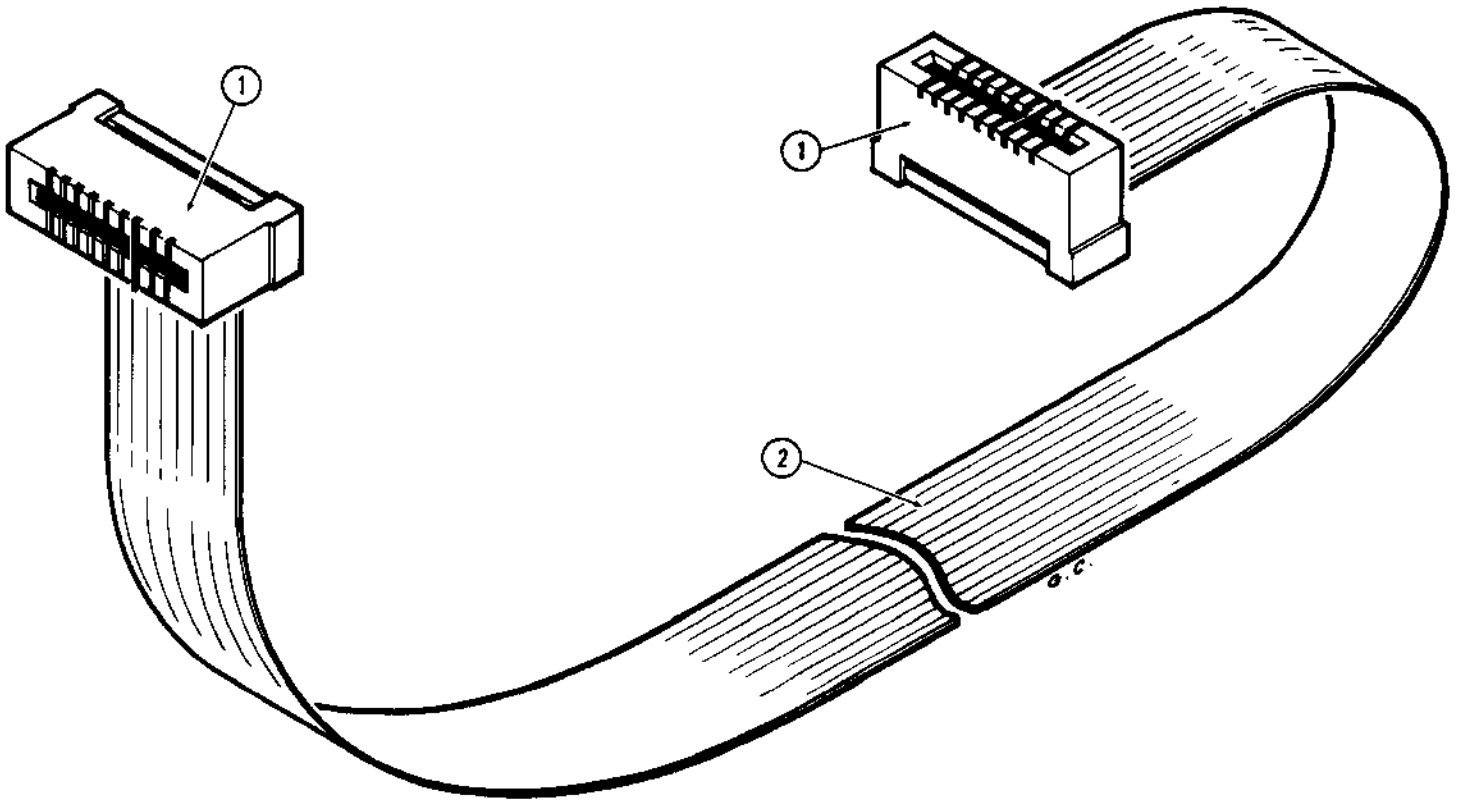

Figure 3-2
23731 KEYBOARD CABLE ASSEMBLY

SECTION III.2

23731 KEYBOARD CABLE ASSEMBLY

<u>ITEM</u>	<u>PART NO.</u>	<u>DESCRIPTION</u>
1	26059-20	Connector, PCB Edge, 20-Pin
2	10588-11	Flat Cable, 20-Conductor

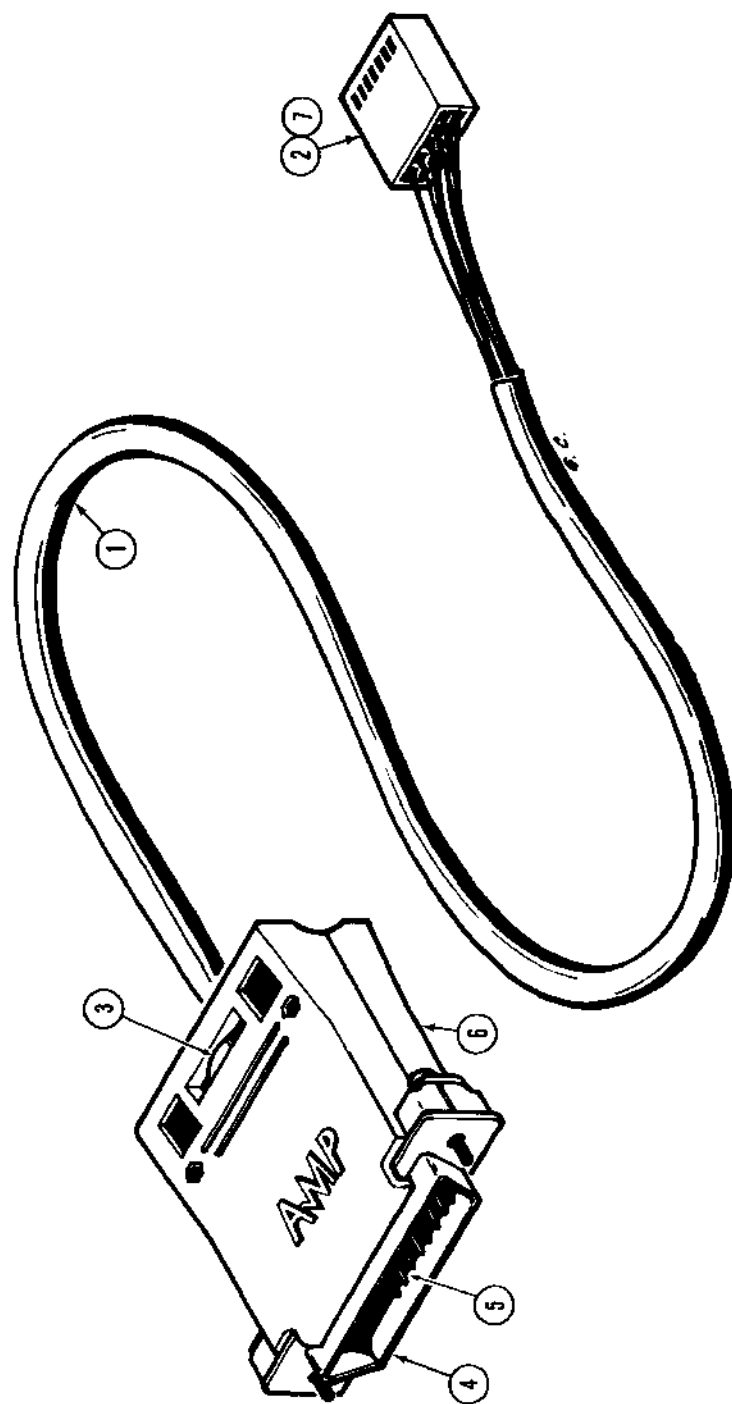

Figure 3-3
23730-01 EIA CABLE ASSEMBLY, COMMON
23939-01 EIA CABLE ASSEMBLY, FOXBORO

SECTION III.3

23730-01 EIA CABLE ASSEMBLY, COMMON
23939-01 EIA CABLE ASSEMBLY, FOXBORO

<u>ITEM</u>	<u>PART NO.</u>	<u>DESCRIPTION</u>
1	10904-10	Cable, #22, 10-Conductor
2	10890-04	Housing, Connector, 12-Pin
3	10967-02	Cable Tie
4	10936-25	Housing, Connector
5	10939-01	Contact, Pin
6	10947	Hood, Connector
7	10891-02	Contact, Pin
8	10892	Key, Polarizing

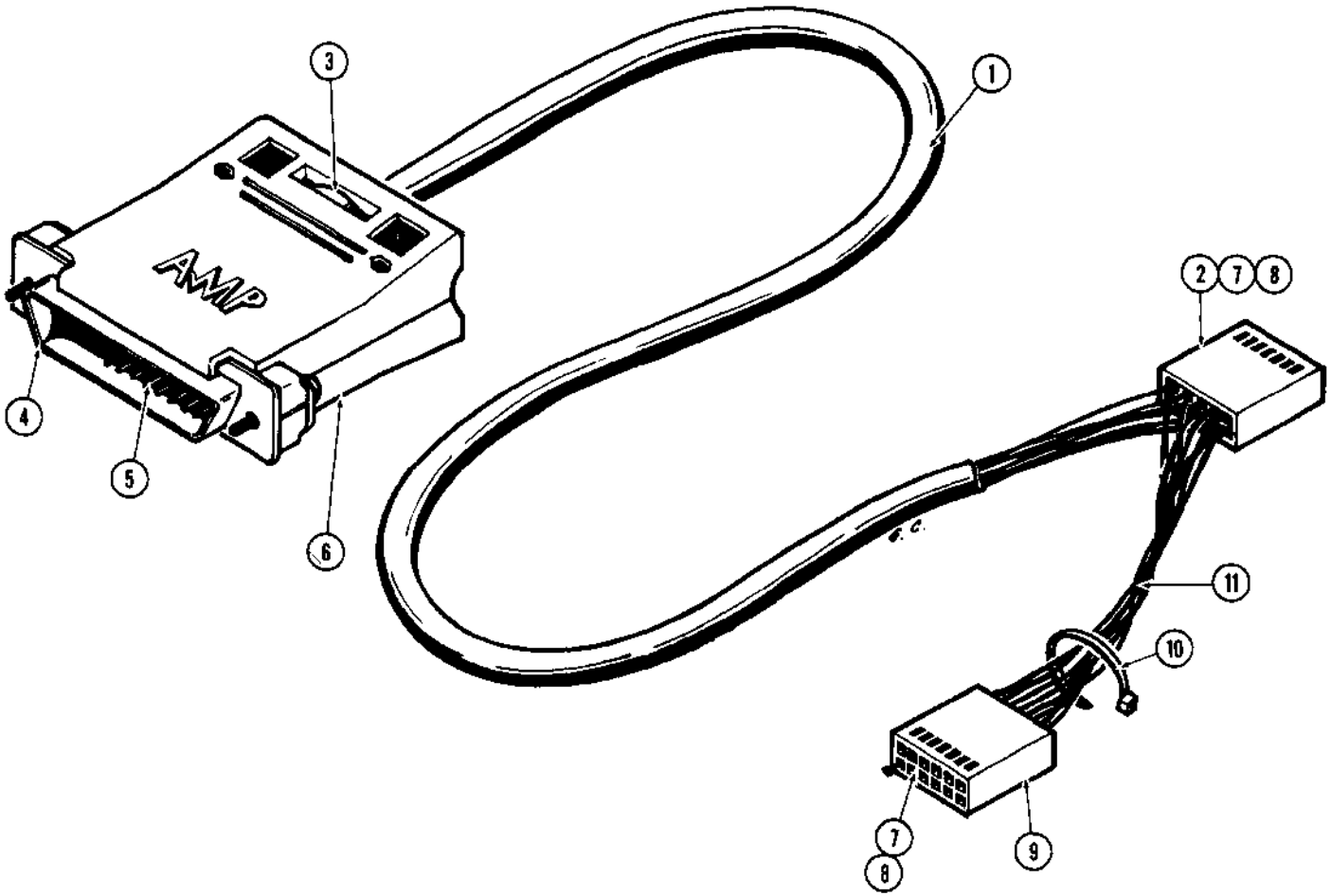

Figure 3-4
400017-01 CURRENT LOOP CABLE ASSEMBLY

SECTION III.4

400017-01 CURRENT LOOP CABLE ASSEMBLY

<u>ITEM</u>	<u>PART NO.</u>	<u>DESCRIPTION</u>
1	10904-05	Cable, #22, 5-Conductor
2	10890-08	Housing, Connector, 14-Pin
3	10967-02	Cable Tie
4	10936-25	Housing, Connector
5	10939-01	Contact, Pin
6	10947	Hood, Connector
7	10891-02	Contact, Pin
8	10892	Key, Polarizing
9	10890-04	Housing, Connector, 12-Pin
10	10538-01	Cable Tie
11	10954-00	Wire, #22, Black
	10954-01	Wire, #22, Brown
	10954-04	Wire, #22, Yellow
	10954-06	Wire, #22, Blue
	10954-08	Wire, #22, Gray

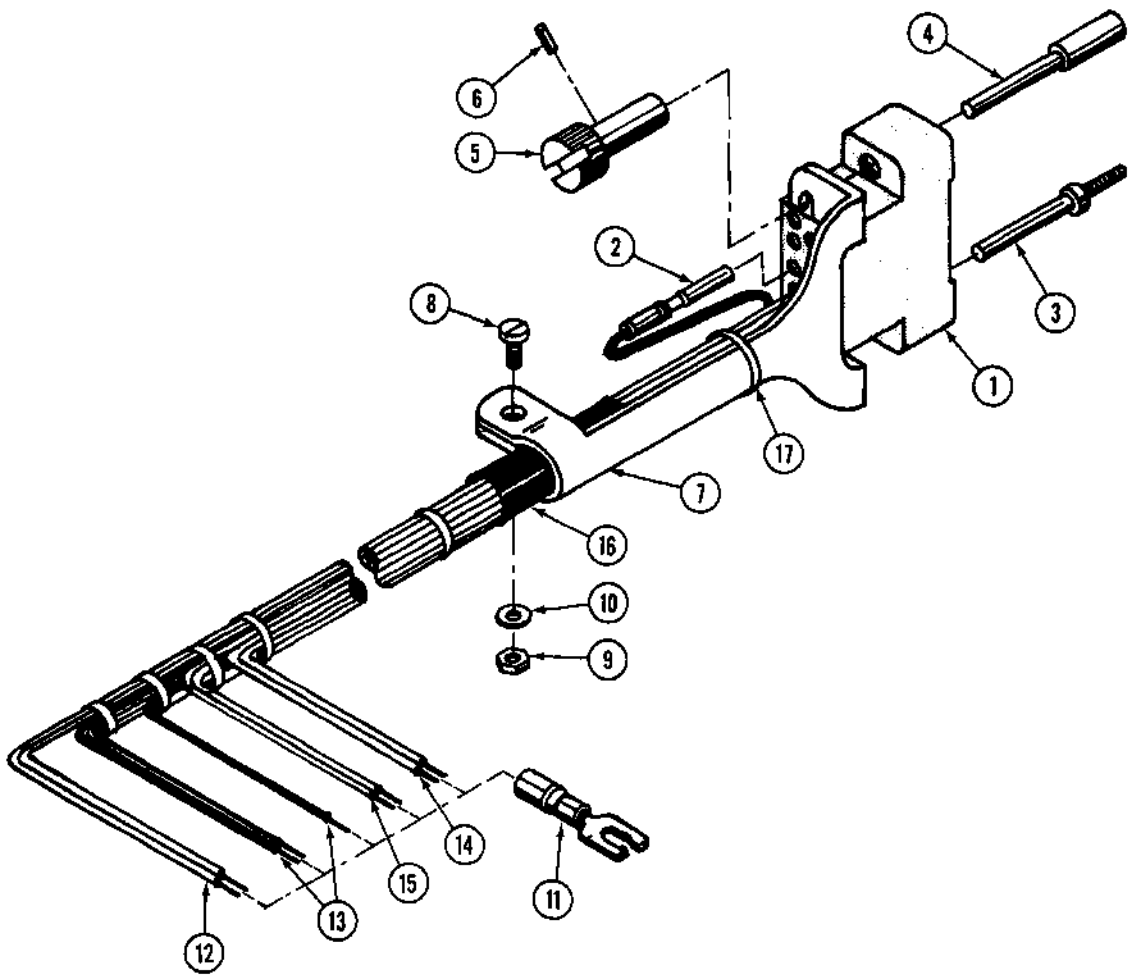

Figure 3-5
23838 DC POWER CABLE ASSEMBLY

SECTION III.5

23838 DC POWER CABLE

<u>ITEM</u>	<u>PART NO.</u>	<u>DESCRIPTION</u>
1	10524-10	Connector, Receptacle, 14-pin
2	10525-11	Contact, Socket, Removable
3	10753	Jackscrew
4	10754	Jacksocket
5	10755	Knob
6	70304-01	Roll Pin, .062 dia.
7	22401	Cable Clamp
8	70029-06	Screw, 4-40 X .375 P.H.
9	70166-04	Nut, 4-40 Hex
10	70196-04	Washer, #4 Flat
11	10969-08	Snap Spade Terminal #6
12	10952-09	Wire, #18 White
13	10952-00	Wire, #18 Black
14	10952-01	Wire, #18 Brown
15	10952-02	Wire, #18 Red
16	10567-37	Sleeving
17	10538-01	Cable Tie

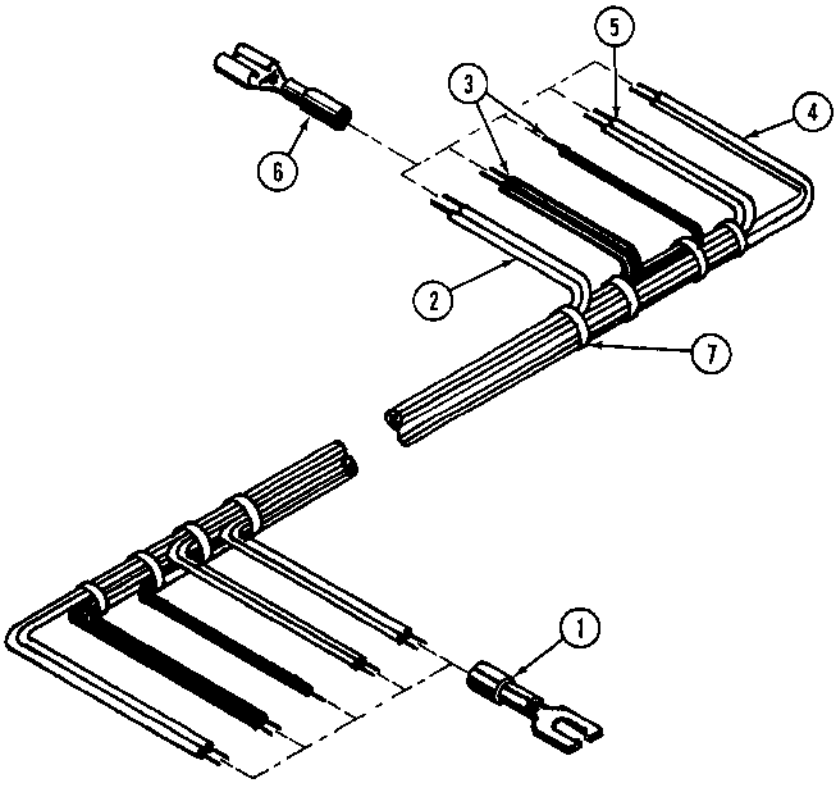

Figure 3-6
26097-01 DC POWER CABLE ASSEMBLY

SECTION III.6

26097-01 DC POWER CABLE

<u>ITEM</u>	<u>PART NO.</u>	<u>DESCRIPTION</u>
1	10969-08	Snap Spade Terminal #6
2	10951-09	Wire, #16 White
3	10951-00	Wire, #16 Black
4	10951-01	Wire, #16 Brown
5	10951-02	Wire, #16 Red
6	10513-11	Terminal, Quick Connect
7	10538-01	Cable Tie

APPENDIX 'A'

23XXX-XX FINAL ASSEMBLY CONFIGURATIONS

	R/O	K/S/R	115VAC Power Supply	230VAC Power Supply	Bottom Feed	Keyboard	10-Key Pad	Color-1	Color-2	HPR01 23702-XX	HPR02 23704-XX	HCURL 23942-XX	Remarks	
23750-12	X	-	X	-	-	-	-	X	-	-	X	-	Model 1610, Standard With: Control Panel Paper Out Switch Assembly Cover Open Switch Assembly	
23750-15	X	-	X	-	X	-	-	X	-	-	X	X		
23750-22	X	-	-	X	-	-	-	X	-	-	X	-		
23750-32	X	-	X	-	-	-	-	-	X	-	X	-		
23750-38	X	-	X	-	X	-	-	-	X	-	X	-		
23750-42	X	-	-	X	-	-	-	-	X	-	X	-		
23750-52	X	-	X	-	-	-	-	X	-	X	-	-		
23750-62	X	-	-	X	-	-	-	X	-	X	-	-		
23700-02	-	X	(1)	-	-	X	X	-	X	-	X	-	Model 1620, Standard With: Typewriter Paired Keyboard Control Panel Paper Out Switch Assembly Cover Open Switch Assembly (1) L & H 3-Output Power Supply	
23700-12	-	X	X	-	-	X	X	X	-	-	X	-		
23700-14	-	X	X	-	-	X	-	X	-	-	X	-		
23700-15	-	X	X	-	-	X	X	X	-	-	X	X		
23700-16	-	X	X	-	-	-	-	X	-	-	X	-		
23700-18	-	X	X	-	X	X	X	X	-	-	X	-		
23700-22	-	X	-	X	-	X	X	X	-	-	X	-		
23700-24	-	X	-	X	-	X	-	X	-	-	X	-		
23700-28	-	X	-	X	X	X	X	X	-	-	X	-		
23700-32	-	X	X	-	-	X	X	-	X	-	X	-		
23700-34	-	X	X	-	-	X	-	-	X	-	X	-		
23700-38	-	X	X	-	X	X	X	-	X	-	X	-		
23700-42	-	X	-	X	-	X	X	-	X	-	X	-		
23700-44	-	X	-	X	-	X	-	-	X	-	X	-		
23700-52	-	X	X	-	-	X	X	X	-	X	-	-		
23850-12	-	X	X	-	-	X	X	X	-	-	X	-	Model 1620, Standard With: Bit Paired Keyboard Control Panel Paper Out Switch Assembly Cover Open Switch Assembly	
23850-14	-	X	X	-	-	X	-	X	-	-	X	-		
23850-16	-	X	X	-	-	-	-	X	-	-	X	-		
23850-22	-	X	-	X	-	X	X	X	-	-	X	-		
23850-24	-	X	-	X	-	X	-	X	-	-	X	-		
23850-32	-	X	X	-	-	X	X	-	X	-	X	-		
23850-34	-	X	X	-	-	X	-	-	X	-	X	-		
23850-42	-	X	-	X	-	X	X	-	X	-	X	-		
23850-44	-	X	-	X	-	X	-	-	X	-	X	-		
23880-22	-	X	-	X	-	X	X	X	-	X	-	-	(1)	Model 1620, European With: Bit Paired Keyboard Control Panel Paper Out Switch Assembly Cover Open Switch Assembly (1) Scandinavian (2) Norsk (3) German (4) French Qwerty (5) French Azerty (6) IBM Compatible
23880-24	-	X	-	X	-	X	-	X	-	X	-	-	(1)	
23880-42	-	X	-	X	-	X	X	-	X	X	-	-	(1)	
23890-22	-	X	-	X	-	X	X	X	-	X	-	-	(2)	
23890-24	-	X	-	X	-	X	-	X	-	X	-	-	(2)	
23890-42	-	X	-	X	-	X	X	-	X	X	-	-	(2)	
23900-22	-	X	-	X	-	X	X	X	-	X	-	-	(3)	
23900-42	-	X	-	X	-	X	X	-	X	X	-	-	(3)	
23910-22	-	X	-	X	-	X	X	X	-	X	-	-	(4)	
23910-24	-	X	-	X	-	X	-	X	-	X	-	-	(4)	
23910-42	-	X	-	X	-	X	X	-	X	X	-	-	(4)	
23950-22	-	X	-	X	-	X	X	X	-	X	-	-	(5)	
23950-42	-	X	-	X	-	X	X	-	X	X	-	-	(5)	
400210-22	-	X	-	X	-	X	X	X	-	X	-	-	(6)	
400210-42	-	X	-	X	-	X	X	-	X	X	-	-	(6)	
23930-12	X	-	X	-	-	-	-	X	-	X	-	-	Models 1610/1620, Foxboro With: Typewriter Paired Keyboard Control Panel Paper Out Switch Assembly Cover Open Switch Assembly	
23930-22	X	-	-	X	-	-	-	X	-	X	-	-		
23960-12	-	X	X	-	-	X	X	X	-	X	-	-		
23960-22	-	X	-	X	-	X	X	X	-	X	-	-		
400300-12	-	X	X	-	-	X	-	X	-	X	-	-	Model 1620, APL With: APL Keyboard Control Panel Paper Out Switch Assembly Cover Open Switch Assembly	
400300-22	-	X	-	X	-	X	-	X	-	X	-	-		
400300-32	-	X	X	-	-	X	-	-	X	X	-	-		
400300-42	-	X	-	X	-	X	-	-	X	X	-	-		

APPENDIX 'B'

COLOR OPTIONS

The following dash numbers should be added when ordering finished parts:

<u>Dash No.</u>	<u>Description</u>
XXXXX-02	Very Light Warm Gray, Textured
XXXXX-04	Warm Black, Textured

APPENDIX 'C'

KEYBOARD OPTIONS

<u>Part No.</u>	<u>Description</u>
23725-XX	46-Key Typewriter Paired, Standard
23726-XX	47-Key Bit Paired, Standard
23882-XX	46-Key Bit Paired, Scandinavian
23892-XX	46-Key Bit Paired, Norsk
23895-XX	46-Key Bit Paired, German
23917-XX	46-Key Bit Paired, French Qwerty
23952-XX	46-Key Bit Paired, French Azerty

NOTE: Add one of the following dash numbers to the above part numbers:

XXXXX-01	Without 10-Key Pad
XXXXX-02	With 10-Key Pad

APPENDIX 'D'

The following accessory items are available for the R/O (1610) and K/S/R (1620) models of HyTerm.

1. Print Wheels:

<u>Part No.</u>	<u>Description</u>
38100-01	Courier 10
38101-01	Pica 10
38102-01	Elite 12
38103	Manifold
38104	Courier Legal 10
38105	Prestige Elite Legal 12
38106-02	Dual Gothic Legal 12
38107-01	Courier 72
38108	Courier Legal 10A
38109	Pica Legal 10A
38131	French Prestige Cubic
38132	German Pica 10
38133	Scandia Elite 12
38135	Kana Gothic Elite 12 (thin Hub)
38136	Kana Gothic Pica 10 (thin Hub)
38137	Kana Gothic Elite 12
38138	Kana Gothic Pica 10
38139	British Pica 10
38140	UK Courier 10
38141	General Scientific 10
38145	OCR-B Kana 10
38146	OCR-B
38147	Forms Gothic S10
38150-01	APL 10
38157	German Elite 12
38159	European Elite 12

2. Ribbons:

<u>Part No.</u>	<u>Description</u>
24150	Black Cloth
24160	Black/Red Cloth
24170	Multi-Strike Carbon Film
24190	Single-Strike Carbon Film

3. Platens:

<u>Part No.</u>	<u>Description</u>
24075-00	Friction Feed
24313-09	Pin Feed (Standard Computer Paper) (14.875" Paper Size, 14.375" Pin to Pin)
24313-10	Pin Feed (15.000" Paper Size, 14.500" Pin to Pin)

4. Tractor Feed Assemblies:

<u>Part No.</u>	<u>Description</u>
24345-03	Tractor Feed NOTE: Must be used with Friction Platen 24075-00, and Short Access Cover 40595-XX, mandatory use with Bottom Feed 40565.

5. Keyboard Installation Kits:

<u>Part No.</u>	<u>Description</u>
400409-01	Typewriter Paired, with 10-Key Pad
400409-02	Bit Paired, with 10-Key Pad
	NOTE: Kits used only for Model 1620 when keyboard is not installed.

6. Current Loop Interface:

<u>Part No.</u>	<u>Description</u>
23942-99	HCURL PCB Assembly
400017-01	Current Loop Cable Assembly (substitute for EIA Cable Assembly, 23730-XX)
	NOTE: This option required that PCB Slot 'F' be available.

7. Publications:

<u>Part No.</u>	<u>Description</u>
82332	Product Description Manual
82333	Maintenance Manual
82334-XX	Parts Catalog
82403-XX	Printer Maintenance Manual
82404-XX	Printer Parts Catalog

8. Miscellaneous:

<u>Part No.</u>	<u>Description</u>
24445	Ribbon Out Sensor (use with carbon film ribbon only)
23744-15	Extension Cable, EIA, 15 ft. (50 ft. maximum length restriction for proper operation)
23742	Extender Board (Maintenance Tool)
40565	Bottom Feed (includes Paper Out Sensor)
	NOTE: KSR versions require bottom pan 24392-03 and RO versions require bottom pan 24391-03. Do not use Top Paper Out Sensor. Tractor Feed 24345-03 mandatory.

COMMENT SHEET

FROM

NAME _____ OFFICE/DEPT NO. _____

CITY/STATE _____ DATE _____

To make this manual more useful to you, we want your comments: what additional information should be included in the manual, what description or figure could be clarified; what subject requires more explanation; what presentation is particularly helpful to you; and so forth.

CUT ALONG LINE

How do you rate this manual: EXCELLENT _____ GOOD _____ FAIR _____ POOR _____

NO POSTAGE NECESSARY IF MAILED IN U.S.A.
FOLD ON TWO LINES (LOCATED ON REVERSE SIDE), STAPLE AND MAIL

FOLD

FOLD

First Class
Permit No. 956
Hayward, Calif.

BUSINESS REPLY MAIL
NO POSTAGE NECESSARY IF MAILED IN THE UNITED STATES

DIABLO SYSTEMS, INC.
24500 INDUSTRIAL BLVD., I-109
HAYWARD, CALIFORNIA 94545

ATTENTION: CS PUBLICATIONS



FOLD

FOLD



XEROX

Diablo Systems Incorporated

24500 Industrial Boulevard
Hayward, California 94545

A Xerox Company