

XEROX

Diablo Systems Incorporated
A Xerox Company

HyTerm Communications Terminal
Model 1610/1620
Product Description

© Copyright 1976, 1977, 1978
Diablo Systems, Inc. (A Xerox Company)
Hayward, California 94545
All rights reserved

"Diablo," "HyType," and "Xerox" are registered trademarks of Xerox Corporation.
"HyTerm" is a trademark of Diablo Systems, Inc.

PREFACE

This manual provides the information necessary to operate, interface, and install the Diablo Model 1610 and Model 1620 HyTerm Communications Terminals.

This revision supercedes all previous revisions, and includes the information contained in Addendum A1, issued on 8-20-76, Addendum C1, issued on 5-26-77, Addendum D1, issued on 9-30-77, Addendum F1, issued on 4-15-78, and Addendum F2, issued on 4-25-78.

Comments on this manual and its use are welcome. Please use the Reader Comment Form in the back of this manual.

Diablo Systems, Inc., reserves the right to make improvements to products without incurring any obligation to incorporate such improvements in units previously sold or delivered. Features and specifications described herein are subject to change without notice.

HOW TO USE THIS MANUAL

This manual is made up of five sections. Not every reader will need to read the entire manual. The first section provides a basic introduction to the HyTerm, and should be read by anyone needing more information about the terminal. Section 2 contains operating instructions, and is meant primarily for the machine operator. Section 3 provides more information on the functional characteristics of the terminal, and is written primarily with the host computer programmer or network designer in mind. Section 4 contains detailed interface data, needed by anyone planning to connect a modem or other device to the terminal. Section 5 contains installation procedures; it is designed for the installer and the installation planner. Those desiring technical information on servicing the terminal should refer to the Model 1610/1620 Maintenance Manual, Publication No. 82333.

WARRANTY

The Diablo Model 1610 and Model 1620 HyTerm Communications Terminals are warranted against defects in materials and workmanship for 90 days from the date of shipment. Any questions with respect to the warranty should be directed to your Diablo sales representative.

All requests for repairs should be directed to the Diablo repair depot in your area. This will assure you of the fastest possible service.

TABLE OF CONTENTS

| PARAGRAPH | PAGE |
|--|------|
| SECTION 1 – GENERAL DESCRIPTION | |
| 1.1 Introduction | 1-1 |
| 1.2 Main Features | 1-1 |
| 1.2.1 Printer | 1-1 |
| 1.2.2 Switch Panels | 1-1 |
| 1.2.3 Keyboard | 1-2 |
| 1.2.4 Communications Capability | 1-2 |
| 1.3 Specifications | 1-2 |
| 1.3.1 Size | 1-2 |
| 1.3.2 Weight | 1-2 |
| 1.3.3 Power Requirements | 1-2 |
| 1.3.4 Environmental Requirements | 1-2 |
| 1.3.5 Printer | 1-2 |
| 1.3.6 Interface | 1-3 |
| 1.3.7 Color | 1-3 |
| 1.4 Functional Features | 1-3 |
| 1.4.1 Control Codes | 1-3 |
| 1.4.2 Escape Sequences | 1-3 |
| 1.4.3 Control Panel and Front Panel Switches | 1-4 |
| 1.5 Optional Features | 1-4 |
| 1.6 Accessories | 1-4 |
| 1.7 Related Documents | 1-5 |
| SECTION 2 – OPERATING INSTRUCTIONS | |
| 2.1 Introduction | 2-1 |
| 2.2 Switches, Indicators, and Controls | 2-1 |
| 2.2.1 Front Panel | 2-1 |
| 2.2.2 Control Panel | 2-1 |
| 2.2.3 Keyboard | 2-5 |
| 2.2.3.1 Alphameric Section | 2-5 |
| 2.2.3.2 Numeric Section | 2-5 |
| 2.2.3.3 Control Section | 2-7 |
| 2.2.4 Printer Controls | 2-7 |
| 2.2.5 Impression Control Switch | 2-8 |
| 2.2.6 Cover-Open Switch | 2-8 |
| 2.2.7 Paper-Out-Switch | 2-9 |
| 2.3 Basic Operating Procedures | 2-9 |
| 2.3.1 Turn-On | 2-9 |
| 2.3.2 Loading Paper | 2-9 |
| 2.3.2.1 Top-Feed Printer | 2-9 |
| 2.3.2.2 Bottom-Feed Printer | 2-10 |
| 2.3.3 Establishing the Data Communications Link | 2-11 |
| 2.3.3.1 Originating a Data Link with an Acoustic Coupler | 2-11 |
| 2.3.3.2 Originating a Data Link with a Bell-Type Modem | 2-12 |
| 2.3.3.3 Originate-Only Modems | 2-12 |
| 2.3.3.4 Answering a Data Link Call | 2-12 |

SECTION 2 – OPERATING INSTRUCTIONS (Continued)

| | | |
|---------|--|------|
| 2.3.4 | Error Recovery | 2-12 |
| 2.3.5 | Keyboard Control of Features. | 2-13 |
| 2.3.5.1 | Margins (ESC 9, ESC 0) | 2-14 |
| 2.3.5.2 | Carriage Movement | 2-14 |
| 2.3.5.3 | Paper Movement | 2-14 |
| 2.3.5.4 | Ribbon Control | 2-14 |
| 2.4 | Operator Duties | 2-15 |
| 2.4.1 | Replacing Ribbon Cartridge | 2-15 |
| 2.4.2 | Changing Printwheels | 2-17 |
| 2.4.3 | Changing Platens | 2-19 |
| 2.4.3.1 | Platen Removal | 2-20 |
| 2.4.3.2 | Standard Platen (Friction-Feed) Installation | 2-20 |
| 2.4.3.3 | Pin-Feed Platen Installation | 2-21 |
| 2.4.4 | Forms Tractor | 2-21 |

SECTION 3 – FUNCTIONAL DESCRIPTION

| | | |
|---------|---|-----|
| 3.1 | Introduction | 3-1 |
| 3.1.1 | Local/Remote | 3-1 |
| 3.2 | Communications Principles | 3-1 |
| 3.3 | Reset/Initialization | 3-1 |
| 3.4 | Character Generation | 3-1 |
| 3.4.1 | Two- and Three-Character Sequences | 3-1 |
| 3.5 | Printing Format | 3-3 |
| 3.5.1 | Definition of Terms | 3-3 |
| 3.5.2 | Standard Formats | 3-3 |
| 3.5.3 | Optional Formats (Variable Indexing) | 3-3 |
| 3.5.3.1 | Variable HMI | 3-4 |
| 3.5.3.2 | Variable VMI | 3-4 |
| 3.6 | Control Functions | 3-4 |
| 3.6.1 | Control of Printing | 3-4 |
| 3.6.1.1 | Red/Black Printing (ESC A/ESC B) | 3-4 |
| 3.6.1.2 | Upper Case Only | 3-4 |
| 3.6.2 | Control of Carriage Movement | 3-5 |
| 3.6.2.1 | Space (SP) | 3-5 |
| 3.6.2.2 | Backspace (BS) | 3-5 |
| 3.6.2.3 | Carriage Return (CR) | 3-5 |
| 3.6.2.4 | Horizontal Tabbing (HT, ESC 1, ESC 2, ESC HT) | 3-5 |
| 3.6.2.5 | Graphics (ESC 3, ESC 4) | 3-6 |
| 3.6.2.6 | Forward/Backward Print (ESC 5/ESC 6) | 3-6 |
| 3.6.2.7 | Margins (ESC 9, ESC 0) | 3-7 |
| 3.6.3 | Control of Platen (Paper) Movement | 3-7 |
| 3.6.3.1 | Line Feeds (LF, ESC LF, ESC U, ESC D) | 3-7 |
| 3.6.3.2 | Form Feed (FF) | 3-7 |
| 3.6.3.3 | Graphics (ESC 3, ESC 4) | 3-7 |
| 3.6.3.4 | Vertical Tabbing (ESC VT) | 3-7 |
| 3.6.4 | Other Control Functions | 3-8 |

SECTION 3 – FUNCTIONAL DESCRIPTION (Continued)

| | | |
|---------|--|-----|
| 3.6.4.1 | Sound Audible Alarm (BEL) | 3-8 |
| 3.6.4.2 | Preventing Buffer Overrun (ACK, ETX, NUL, DEL) | 3-8 |
| 3.7 | Motion Minimization | 3-8 |

SECTION 4 – INTERFACE

| | | |
|-------|--------------------------|-----|
| 4.1 | Introduction | 4-1 |
| 4.2 | Modem Compatibility | 4-1 |
| 4.3 | Functional Description | 4-1 |
| 4.4 | Connection to the Modem | 4-3 |
| 4.5 | Signal Levels | 4-3 |
| 4.6 | Interface Signals | 4-3 |
| 4.7 | Data Format | 4-4 |
| 4.8 | Timing | 4-5 |
| 4.9 | Circuit Elements | 4-5 |
| 4.9.1 | Input Level Converter | 4-5 |
| 4.9.2 | Output Level Converter | 4-6 |
| 4.10 | Current - Loop Interface | 4-6 |

SECTION 5 – INSTALLATION

| | | |
|------------|---|-----|
| 5.1 | Introduction | 5-1 |
| 5.2 | Preliminary Inspection | 5-1 |
| 5.3 | Unpacking and Inspection | 5-1 |
| 5.4 | System Requirements | 5-1 |
| 5.4.1 | Operating Environment | 5-1 |
| 5.4.2 | Space Requirements | 5-1 |
| 5.4.3 | Weight | 5-1 |
| 5.4.4 | Power Requirements | 5-1 |
| 5.5 | Installation Procedures | 5-1 |
| 5.5.1 | Initial Start-up and Checkout | 5-3 |
| 5.5.2 | Jumper Installation/Removal | 5-3 |
| 5.5.2.1 | 1200 Baud | 5-3 |
| 5.5.2.2 | Ground Disconnect | 5-5 |
| 5.5.3 | EIA Cable Assembly Connection and Remote Checkout | 5-5 |
| 5.6 | Repackaging for Shipment | 5-5 |
| Appendix A | ASCII Code Chart | A-1 |
| Appendix B | Keyboard Layouts and Code Charts | B-0 |

LIST OF ILLUSTRATIONS

| FIGURE | | PAGE |
|--------|---|------|
| 1-1 | HyTerm Communications Terminal | 1-0 |
| 2-1 | Switches, Indicators, and Controls | 2-0 |
| 2-2 | Front Panel | 2-1 |
| 2-3 | Control Panel | 2-3 |
| 2-4 | 46-Key Typewriter Pairing Keyboard | 2-4 |
| 2-5 | Printer Controls | 2-6 |
| 2-6 | Cover-Open and Impression Control Switches | 2-8 |
| 2-6a | Paper-Out Switch Clip | 2-9 |
| 2-7 | Ribbon Clamps | 2-15 |
| 2-8 | Ribbon Advance Knob | 2-16 |
| 2-9 | Ribbon Cartridge Placement | 2-16 |
| 2-10 | Carriage Tilted for Printwheel Access | 2-17 |
| 2-11 | Printwheel Installation | 2-18 |
| 2-12 | Printwheel | 2-18 |
| 2-13 | Platen Skirt Removal | 2-19 |
| 2-13a | Platen Removal | 2-19 |
| 2-14 | Pin-Feed Platen Installation | 2-20 |
| 2-15 | Plastic Clip and Stud | 2-21 |
| 2-16 | Forms Tractor | 2-22 |
| 2-17 | Forms Tractor and Platen Adjust Lever | 2-22 |
| 2-18 | Forms Tractor and Paper Release Lever (Tension Removed) | 2-23 |
| 2-19 | Forms Tractor and Paper Release Lever (Tension Removed) | 2-23 |
| 2-20 | Forms Tractor Installed | 2-24 |
| 3-1 | Printing Format Factors | 3-2 |
| 4-1 | Interface Functional Block Diagram | 4-1 |
| 4-2 | Interface Connector | 4-2 |
| 4-3 | Input Line Switching Levels | 4-3 |
| 4-4 | Data Format on Interface | 4-4 |
| 4-5 | Input Converter IC | 4-5 |
| 4-6 | Output Converter IC | 4-6 |
| 4-7 | Current Loop Cable Pinout | 4-6 |
| 5-1 | Top Cover Release Lever | 5-2 |
| 5-2 | HPRO Board Location | 5-2 |
| 5-3 | Jumper Location | 5-4 |
| 5-4 | Current Loop Connections | 5-6 |

LIST OF TABLES

| TABLE | | PAGE |
|-------|---|------|
| 2-1 | Front Panel Switches and Indicators | 2-2 |
| 2-2 | Control Panel | 2-3 |
| 2-3 | Error Recovery | 2-13 |
| 3-1 | Standard Formats | 3-3 |
| 3-2 | Decimal Values for ASCII Character | 3-4 |
| 3-3 | Control Functions | 3-5 |
| 4-1 | Interface Signals | 4-2 |
| 4-2 | Interface Signal Terminology | 4-3 |
| 4-3 | Interface Data Timing | 4-5 |
| 5-1 | Jumper/Shorting Plug Location | 5-5 |

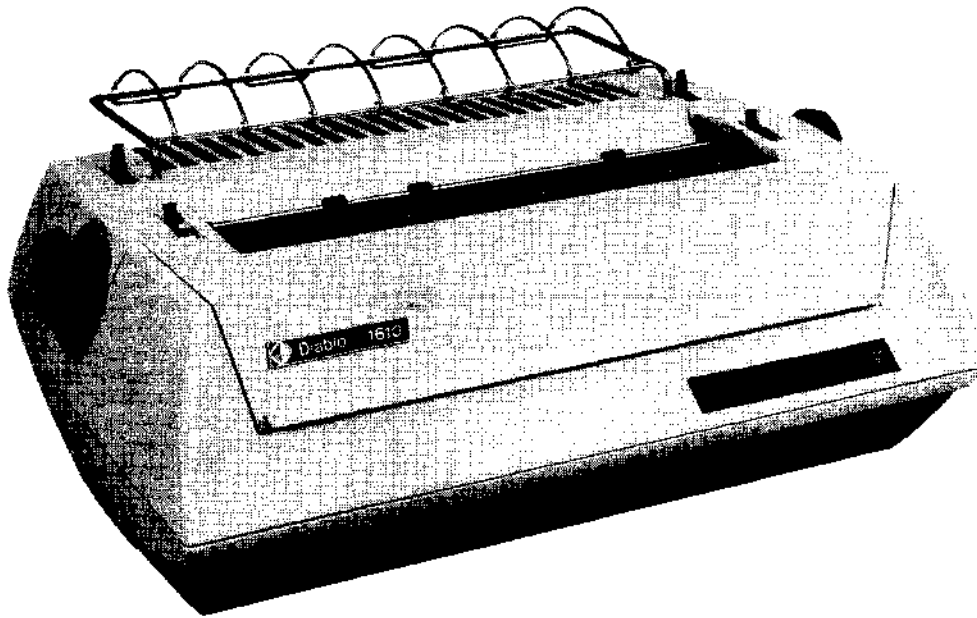

MODEL 1610

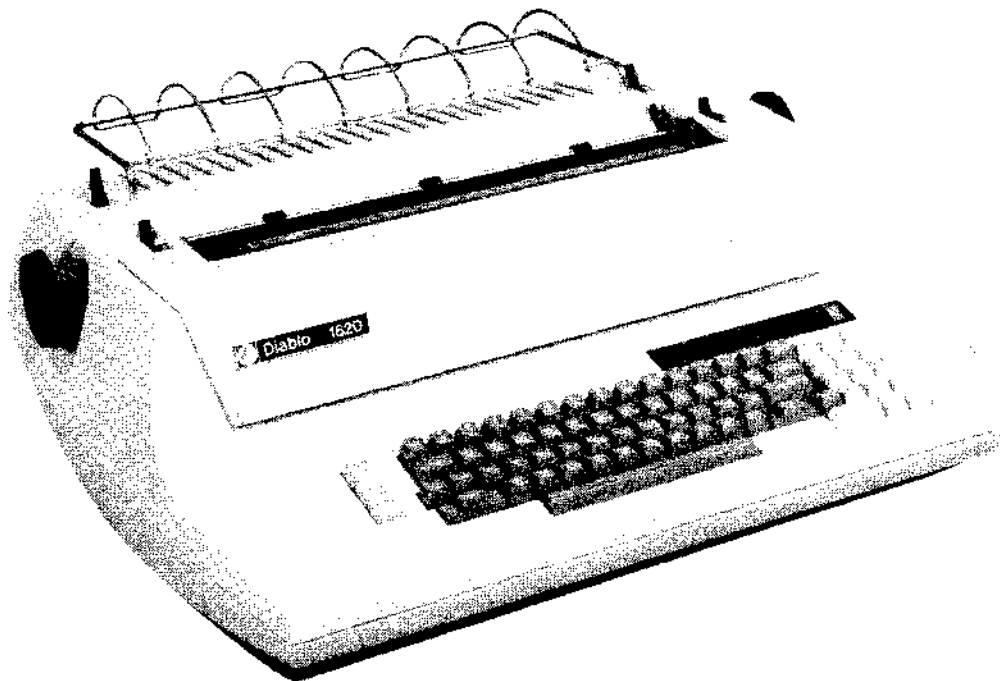

MODEL 1620

Figure 1-1. HyTerm Communications Terminal

SECTION 1 GENERAL DESCRIPTION

1.1 INTRODUCTION

Diablo Systems has combined the latest technology in printers and microelectronics to produce the HyTerm communications terminal, Figure 1-1. The HyTerm is one of the smallest and most convenient terminals built, yet it is one of the most economical and versatile units available today. The HyTerm transmits data to and receives data from a distant device over a communication link via an EIA Standard RS-232-C interface. In local operation, the keyboard/printer can also serve as a document writer for correspondence and other secretarial functions. As a communications terminal, the HyTerm can function in a variety of applications: in terminal-to-terminal communications, as a computer console or output printer, as a terminal in a time-sharing network, as a console in a text-editing system, etc.

The HyTerm comprises a Diablo HyType II printer and microprocessor-driven electronics, contained in an attractive yet functional package. The HyTerm's modular design provides exactly the amount of capability needed in any data communications application. The HyTerm Model 1610 is a receive-only (RO) version, while the Model 1620 has keyboard send/receive (KSR) capability. Both models contain an integral power supply, making them a completely self-contained table top unit. The HyType II's inherent speed and adaptability, and the microprocessor's versatility, plus a full complement of type styles and optional forms-handling equipment, enable the HyTerm to meet the most demanding data processing situations.

1.2 MAIN FEATURES

The HyTerm communicates using the U.S.A. Standard Code for Information Interchange (ASCII), and is compatible with most other data communications devices utilizing this code. It provides medium speed, high-quality printing of all 94 printable ASCII characters on an original form and up to 5 copies. It is compatible with Bell type 103A and 113A modems and many other 110- to 300-baud asynchronous modems employing the RS-232-C interface specifications set forth by the Electronic Industries Association (EIA).

The HyTerm represents an innovative approach to all facets of terminal design. For ease of maintenance, all electronic components are contained on circuit boards that plug into the HyType II printer. The capabilities inherent in the design of the HyType II have been enhanced by the microprocessor control to provide unmatched versatility, reliability, and speed. Functional capabilities reside in pre-programmed Read-Only Memory (ROM), and not in

difficult-to-modify, space consuming, hard-wired random logic. This makes several functional features available "free," which can be used when desired, but which "cost nothing" even if they are not utilized. In addition, the complete flexibility of the HyType II mechanism is maintained in the interface design so that appropriate external commands can take advantage of the HyType's graphics capability, its high-speed horizontal and vertical tabbing, its non-left-margin returns, and its backward printing capability.

1.2.1 Printer

The HyType II's innate qualities — its speed, versatility, serviceability, reliability, and excellent print quality — are complemented by the microprocessor control to provide a remarkable printing system. The small number of moving parts, the straightforward mechanical design, and the modularity of the plug-in circuit boards are all contributing factors. Interchangeable daisy-wheel type fonts provide printing of 95 different characters at either 10 or 12 characters per inch. Rapid carriage and paper movement provide high-speed horizontal and vertical tabbing. The HyType II is capable of printing at a nominal speed of 45 characters per second (cps), even though it is usually driven at only 10 to 30 cps by the communications link. Normal graphics capability provides horizontal resolution to 1/60" and vertical resolution to 1/48", but horizontal movement in 1/120" increments is available to provide wide variety in the choice of printing format.

Microprocessor control of the preceding features adds the capacity for backward printing (eliminating carriage return time), absolute tabbing (tabbing directly to a specified print column or line without having previously set a tab stop), and "motion minimization." This latter feature resolves a sequence of carriage- and paper-movement commands to one single operation which moves the print head via the shortest path to the position which would result from performing each individual operation. All of these factors contribute to increased throughput.

1.2.2 Switch Panels

Front panel switches provide for error RESET, and control of FORM FEED, SET TOF (Top of Form), SCROLL, and POWER. With these front panel switches come indicators for ERROR and POWER, and an audible alarm buzzer. A control panel is also provided for selection of baud rate, auto line feed, parity, spacing, half/full duplex, form length, and terminal reset/initialization.

1.2.3 Keyboard

Keyboard accommodations include choice of typewriter pairing or logical bit pairing arrays, or several European arrays, all with an auxiliary ten-key numeric pad. Additional features are provided by keyboard function keys, e.g., Local/Remote, Upper Case Only, Break.

All keyboards utilize highly-reliable keyswitches with n-key rollover, which means all key signals are transferred to the microprocessor in the same sequence in which their corresponding keys were depressed. Thus no useful keyboard data is ever lost, regardless of the speed at which the keys are operated.

1.2.4 Communications Capability

The Hyterm can be interfaced to a data communications network through a Bell type 103A or 113A (or equivalent) modem. An optional current loop interface is also available. Time Division Multiplexed (TDM) or Frequency Division Multiplexed (FDM) equipment may be used in place of a modem, providing the multiplexing equipment has the same interface characteristics as the above-listed modems. The HyTerm communicates in either half-duplex or full-duplex mode at rates of 110, 150, or 300 baud, which translate into 10, 15, or 30 characters per second (cps) respectively. Each incoming character can be checked for proper parity, and a parity bit is generated for each transmitted character. Received characters pass through an input buffer having a capacity of 158 characters, thus negating the need for "pad" or time-fill characters in the received data. A simple ETX/ACK protocol is also built into the microprocessor program, which can be used to guarantee no data loss should the data contain large numbers of paper movement commands or other codes that might slow down the printer. Outgoing characters pass through an 8-character transmit buffer.

A strappable option enables full-duplex data transmission/reception at 1200 baud (120 cps). This mode enables the HyType II printer to operate at its full rated speed of 45 cps, and makes the HyTerm especially suited for use as a computer console or local I/O device. When the 1200 baud rate is used, the ETX/ACK protocol should be employed to prevent data overrun.

1.3 SPECIFICATIONS

1.3.1 Size

| | | |
|-------------|-----------|---------|
| Height | 8.25 in. | 21.0 cm |
| Width | 23.25 in. | 59.1 cm |
| Depth (KSR) | 20.3 in. | 51.6 cm |
| Depth (RO) | 15.7 in. | 39.9 cm |

1.3.2 Weight

48 lbs. (21.8 kg), including covers and power supply.

1.3.3 Power Requirements

Two power supplies are available. The domestic version requires 95 to 130 Vac, at 60 Hz. The export version operates on 190 to 260 Vac, at 50 Hz. Both units consume approximately 200 watts. A 12-foot (3.7-meter) power cord is provided.

1.3.4 Environmental Requirements

| | | Operating | Storage |
|---|-----|---------------------|---------------------|
| Temperature Range (Degrees Fahrenheit/ Celsius) | MIN | 45/7 | -20/-29 |
| | MAX | 95/35 | 135/57 |
| Relative Humidity Range (at 80° F. Maximum wet bulb temperature, no condensation) | MIN | 10% | 0% |
| | MAX | 80% | 90% |
| Altitude Range | MIN | Sea Level | Sea Level |
| | MAX | 10,000 ft/ 3048m | 25,000 ft/ 7620m |

1.3.5 Printer

- (1) Print Speed: up to 45 characters per second on average text, actual rate dependent upon baud rate used.
- (2) Character set: 95 characters, variable depending upon printwheel selected.
- (3) Print line: 13.2 inches

132 columns @ 10 characters per inch
158 columns @ 12 characters per inch
(Variable spacing capability standard)
- (4) Paper width: 15 inches (38.1 cm) maximum.
- (5) Paper thickness (one or more copies): up to .027" (0.69 mm), manual selection.
- (6) Carriage return time: 300 ms maximum.
- (7) Horizontal tabulation: right or left, direct to addressed print position.
- (8) Vertical tabulation: up or down, direct to addressed line.
- (9) Line feed: either direction, full or half line. Normal line spacing is 6 lines per inch (variable line spacing capability is standard).

- (10) Paper feed speed: 4 inches per second, plus 50 ms settling delay. Paper is normally fed into the printer from the back, like a typewriter, but a bottom-feed option is available.
- (11) Plotting resolution: horizontal, 60 positions per inch; vertical, 48 positions per inch.
- (12) Paper-out sensor: stops HyTerm and signals operator when form supply is depleted.

1.3.6 Interface

Both models communicate using ASCII code, and contain a 158-character receive buffer. The Model 1620 HyTerm contains an 8-character send buffer.

The data communications interface exhibits the following characteristics:

- (1) Electrically compatible with EIA RS-232-C and C.C.I.T.T. V-24.
- (2) Functionally compatible with Bell 103A, 103E, 103F, 103G, 103H, 113A, and TDM or FDM equipment.
- (3) Full/Half Duplex.
- (4) Even/odd/mark parity generation and error detection.
- (5) Framing error and overrun error detection.
- (6) Baud rate: 110, 150, or 300 standard; 1200 strapable.
- (7) ETX/ACK protocol capability standard.
- (8) Ten-foot modem cable standard. Additional extension cables available.

1.3.7 Color

Standard color is Diablo textured warm black. Diablo textured very light warm gray is also available.

1.4 FUNCTIONAL FEATURES

The microprocessor control and ROM resident micro-program make available in the HyTerm several functional features which are either extra-cost options or not even available on other terminals. Most of these functions are utilized by sending the HyTerm either a single ASCII control code or an "escape" sequence, which is the ESC character followed by another ASCII character. Other features, such as automatic line feed, 10 or 12 characters-per-inch spacing, etc., are locally controlled via switches.

1.4.1 Control Codes

- (1) BS Backspace
- (2) CR Carriage Return
- (3) HT Horizontal Tab (to preset tab stop)
- (4) LF Line Feed
- (5) FF Form Feed
- (6) ETX Send ACK
- (7) BEL Sound Audible Alarm
- (8) SP Space

1.4.2 Escape Sequences

- (1) ESC 1 Set horizontal tab stop
- (2) ESC 2 Clear all tab stops
- (3) ESC 3 Graphics on
- (4) ESC 4 Graphics off (CR also clears)
- (5) ESC 5 Forward Print on
- (6) ESC 6 Backward Print on (CR also clears)
- (7) ESC 8 Clear individual tab stop
- (8) ESC 9 Set left margin
- (9) ESC 0 Set right margin
- (10) ESC A Print in red
- (11) ESC B Print in black
- (12) ESC D Negative half-line feed
- (13) ESC U Half-line feed
- (14) ESC HT (n) Absolute horizontal tab to position (n).
- (15) ESC VT (n) Absolute vertical tab to line (n)
- (16) ESC LF Negative line feed
- (17) ESC RS (n) Define vertical spacing equal to n-1 x 1/48 inch.
- (18) ESC US (n) Define horizontal spacing equal to n-1 x 1/120 inch.

1.4.3 Control Panel and Front Panel Switches

The following features can be selected locally via the control panel switches.

- (1) Half/Full Duplex
- (2) Parity (even, odd or "mark")
- (3) Auto Line Feed
- (4) Spacing (10 or 12 characters per inch)
- (5) Speed (baud rate), except 1200 baud
- (6) Form Length
- (7) Clear (Reset)

The following features are available through the front panel switches:

- (1) Form Feed
- (2) Set Top of Form
- (3) Error lamp
- (4) Error Reset switch
- (5) Power switch and indicator
- (6) Scroll

1.5 OPTIONAL FEATURES

- (1) Pin-feed platen
- (2) Current-loop interface
- (3) EIA extension cable
- (4) Special keyboards (see Appendix B)
- (5) Bottom forms-feed (includes paper-out sensing; requires forms tractor)

1.6 ACCESSORIES

- (1) Film ribbon, multi-strike
- (2) Red/black cloth ribbon
- (3) Printed circuit board extender

(4) Printwheels

- *Courier 10
- *Pica 10
- *Elite 12
- Manifold 10
- Courier Legal 10
- Prestige Elite Legal 12
- Dual Gothic Legal 12
- *Courier 72
- Courier Legal 10A
- Pica Legal 10A
- French Prestige Cubic
- German Pica 10
- Scandia Elite 12
- Kana Gothic Elite 12
- Kana Gothic Pica 10
- British Pica 10
- UK Courier 10
- APL 10
- General Scientific 10
- Symbol 10
- OCR A
- OCR B
- OCR B Kana 10
- Russian Cubic 10
- Norsk Pica 10
- *Forms Gothic S-10

Printwheels above marked with an asterisk (*) are 100% compatible with the 46-key typewriter pairing and 47-key bit pairing keyboards. Other printwheels are compatible with certain other keyboards; refer to Appendix B for details. Any printwheel can be used with a given keyboard, but some printwheel characters will differ from the corresponding keyboard legends. In most cases, the alphabetic and numeric characters will be the same, and the differences will be in some of the special symbols. Contact your Diablo representative for details on any particular printwheel.

Diablo is continually making new printwheels available; refer to publication CS508-XX for the latest listing and for type samples of all currently available printwheels.

1.7 RELATED DOCUMENTS

- (1) HYTERM COMMUNICATIONS TERMINAL, MODEL 1610/1620, MAINTENANCE MANUAL, June, 1976. Diablo Systems, Inc. Publication No. 82333.
- (2) SERIES 1300 HYTYPE II PRINTER PRODUCT DESCRIPTION, January, 1976. Diablo Systems, Inc. Publication No. 82402.
- (3) SERIES 1300 HYTYPE II PRINTER PARTS CATALOG, June, 1976. Diablo Systems, Inc. Publication No. 82404.
- (4) SERIES 1600 HYTERM TERMINAL PARTS CATALOG, November, 1976. Diablo Systems, Inc. Publication No. 82334.
- (5) INTERFACE BETWEEN DATA TERMINAL EQUIPMENT AND DATA COMMUNICATION EQUIPMENT EMPLOYING SERIAL BINARY DATA INTERCHANGE. EIA Standard RS-232-C, August, 1969. Engineering Dept., Electronic Industries Assn., 201 Eye St. N.W., Washington, D.C. 20006.
- (6) "C.C.I.T.T. GREEN BOOK," Volume VIII, Data Transmission, 1973. The International Telegraph and Telephone Consultative Committee, International Telecommunication Union, Geneva.
- (7) USA STANDARD CODE FOR INFORMATION INTERCHANGE, USAS X3.4-1977. American National Standards Institute, 1430 Broadway, New York, N.Y. 10018.
- (8) DATA SET 103A INTERFACE SPECIFICATION, February, 1967. Engineering Director, Data Communications, American Telephone and Telegraph Co. Publication 41101.
- (9) 113-TYPE DATA STATION INTERFACE SPECIFICATION, October, 1971. Engineering Director, Transmission Services, American Telephone and Telegraph Co. Publication 41105.

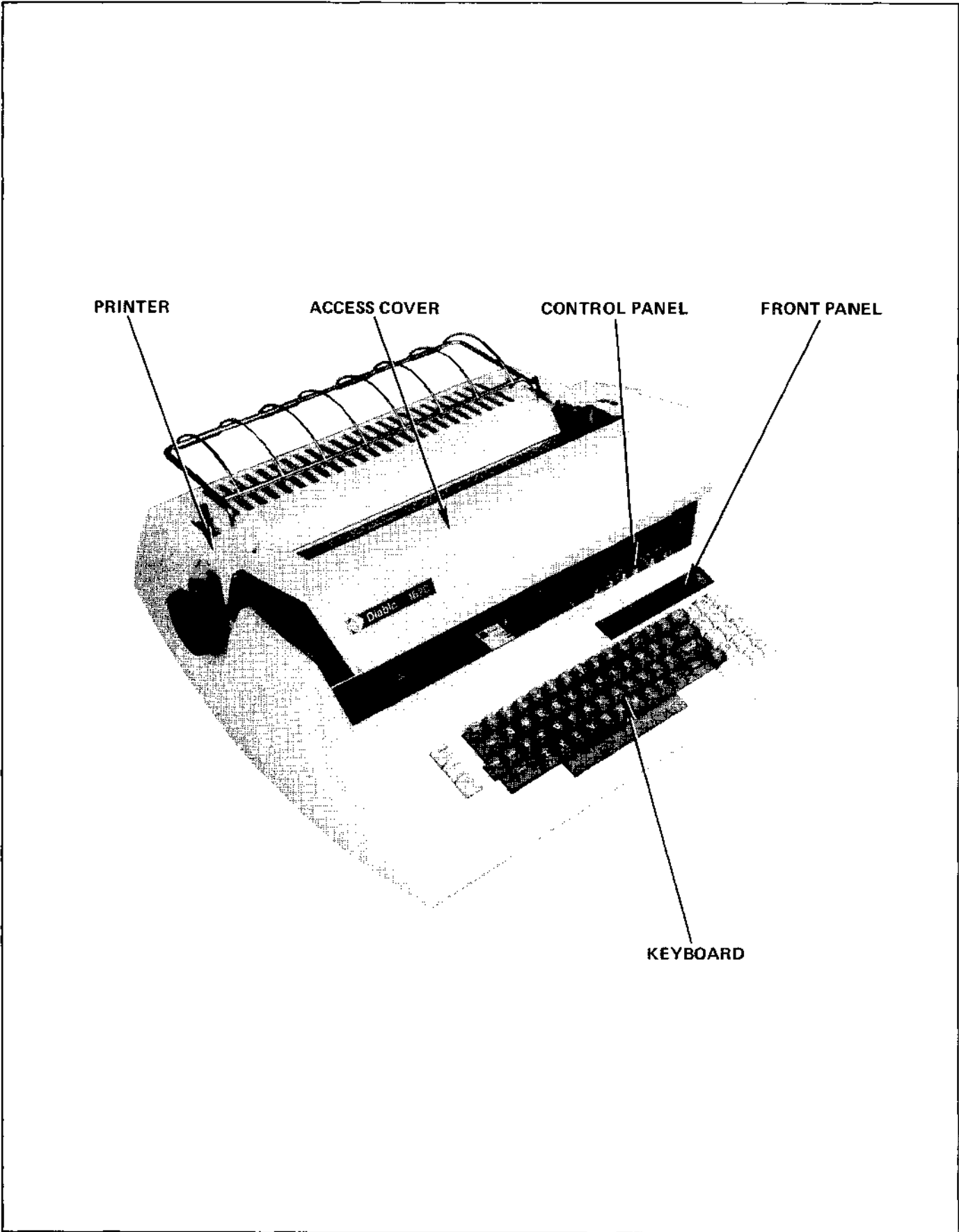

Figure 2-1. Switches, Indicators, and Controls

SECTION 2 OPERATING INSTRUCTIONS

2.1 INTRODUCTION

Only general operating instructions are provided in this section. Specific procedures are dependent upon the model HyTerm being used and the options included, as well as the application being performed and the characteristics of the data communications network in which the HyTerm is used. However, certain basic operating steps are the same in all cases. These steps will be covered in this section, as well as steps required with certain optional equipment. Refer to Section 3, Functional Description, for additional information and for functions not covered in this section.

WARNING

Always keep hair, fingers, jewelry, etc., out of the area around the printwheel and carriage. The high-speed printing mechanism of the HyType II printer moves much faster than an ordinary typewriter, and since printing can be initiated remotely, a sudden unexpected movement could inflict injury. Be especially careful when the access cover is removed, as when changing ribbons, etc.

2.2 SWITCHES, INDICATORS, AND CONTROLS (Figure 2-1)

The more frequently used controls and indicators are contained on the printer, the keyboard, and the front switch panel which is just above the keyboard on the right side. Others are contained on the control panel located inside the printer; raise the printer access cover [see 2.2.4(6)] to expose this panel. Generally, the control panel switches are adjusted before starting operation, and the front panel, keyboard, and printer controls are used during operation. The audible alarm is used mainly to indicate the occurrence of an error.

2.2.1 Front Panel (Figure 2-2)

Table 2-1 describes the switches and indicators contained on the front panel.

2.2.2 Control Panel (Figure 2-3)

Table 2-2 describes the switches located under the printer access cover.

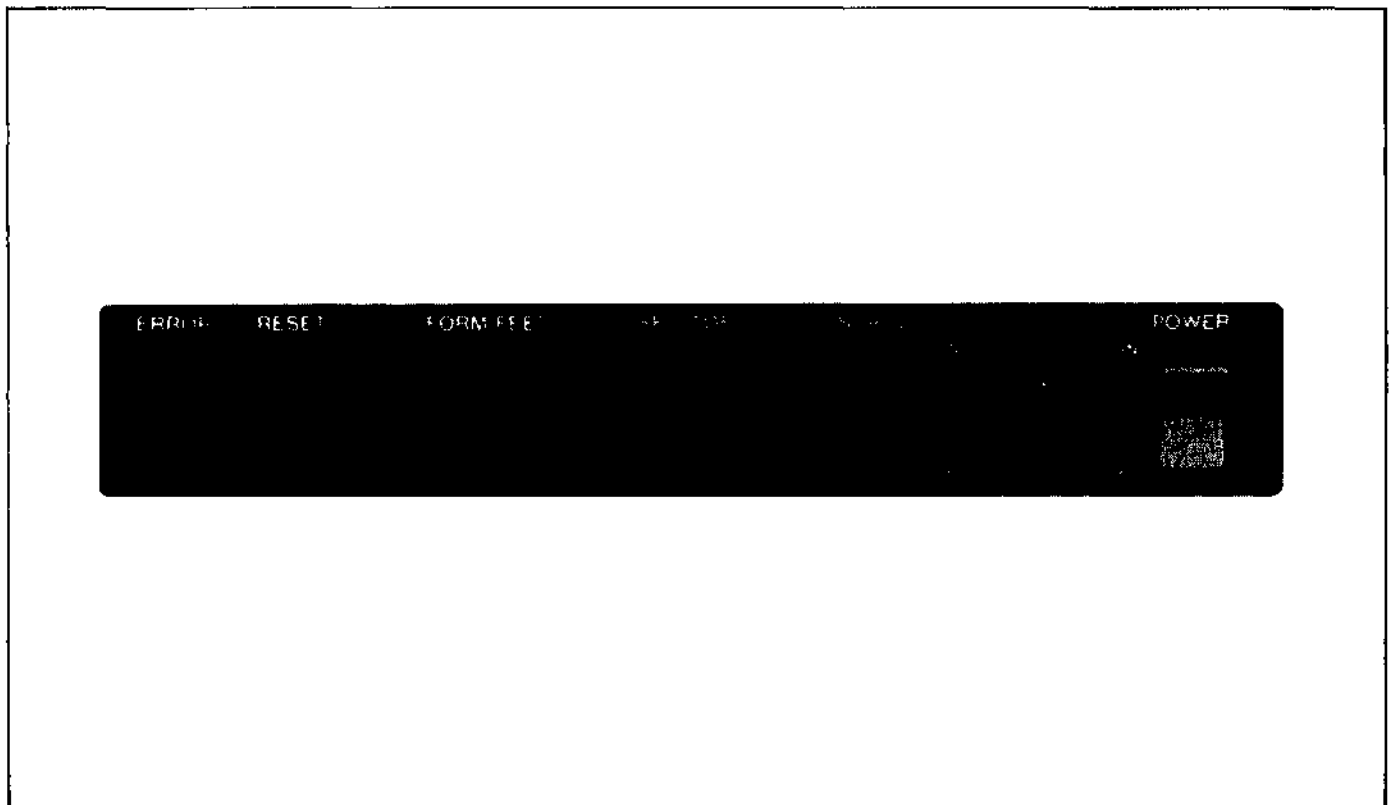

Figure 2-2. Front Panel

Table 2-1. Front Panel Switches and Indicators

| Name | Function |
|-----------------------|---|
| ERROR (indicator) | Lights for any of the following error conditions: parity, overrun, framing, printer cover open, check, out-of-paper. The last three errors are indicated only if printing is attempted. |
| RESET | Turns off error lamp after the condition that caused the error has been cleared. Resets errors (see audible alarm). (A printer check requires a clear operation; see Table 2-2.) |
| FORM FEED | Moves paper up to the top line of the next form. |
| SET TOF (Top of Form) | Operate this switch after installing forms and manually positioning them to the first line. (Make sure the SCROLL switch is off.) This synchronizes the HyTerm electronics to the form position. Operating this switch also loads the setting of the FORM LENGTH switch (Table 2-2) into the HyTerm's memory. |
| SCROLL | <p>With this switch on, the paper moves up approximately one second after a character is printed so that the printing can be easily seen. Before another character is printed, the paper automatically moves down to align the printing on the same line. When several characters are printed in succession, the paper remains down until one second after the last character is printed. Turning this switch off defeats the scroll feature. The switch should be off when inserting paper and when setting the top of form.</p> <p>Print quality may be affected if the scroll feature is used along with a forms tractor or single-cam (unidirectional) pin-feed platen. Since these devices are not designed to move paper in the reverse direction, the printed line may exhibit some waviness when the scroll feature is used. Also, if the form is backed up over page boundaries (perforations), some bunching or jamming of the forms may occur. For best results, a friction platen or a dual-cam (reversible) pin-feed platen should be used.</p> <p style="text-align: center;">NOTE</p> <p style="text-align: center;"><i>When the SCROLL switch is turned on, the paper moves up immediately. When it is turned off, the paper does not move down until the next character is printed or the next printer function is performed. Therefore, when inserting paper and setting top of form, if the SCROLL switch is on, first turn it off, and then operate the space, carriage return, line feed, or some other key, before attempting to align the paper to the top line.</i></p> |
| Audible Alarm | <p>Sounds for 1/4 second for each new type of error. Additional errors of the same type do not sound the alarm (unless errors have been reset), but the first error of a different type will.</p> <p>Also sounds when BEL character is received or when printing exceeds right margin. (This can only occur when the right margin has been set at some print position short of the "maximum.")</p> |
| POWER (indicator) | Lights whenever power is present in the HyTerm. |
| POWER (switch) | Controls ac power to HyTerm. When power is first applied, a clear operation takes place. |

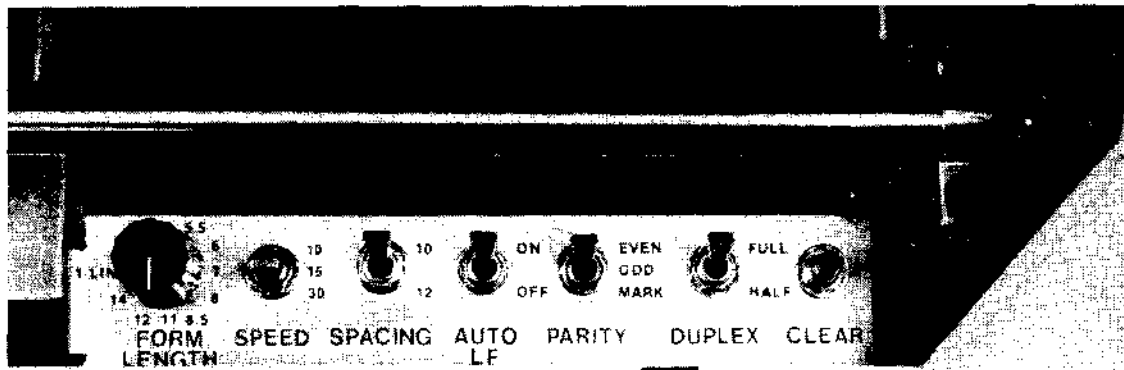

Figure 2-3. Control Panel

Table 2-2. Control Panel

| Switch | Function |
|-------------|--|
| FORM LENGTH | This is a 12-position rotary switch used in conjunction with the SET TOF switch on the front panel. This switch is set to indicate the size of the form being used and then the SET TOF switch is depressed to load this value into the HyTerm's memory. (Make sure the SCROLL switch is off.) Form length can be one line, (1/6 inch) or 3, 3.5, 4, 5.5, 6, 7, 8, 8.5, 11, 12, or 14 inches. This switch must be set to correspond with the size of form being used in order to allow form feeds and absolute vertical tabs to operate properly. The setting of this switch is also loaded into memory automatically at power on. |
| SPEED | This is a three-position toggle switch that selects the data communications transmit/receive speed of 10, 15, or 30 characters per second. It must be set according to communications network requirements. If the HyTerm is wired for 120 cps speed, this switch is non-functional. |
| SPACING | This two-position toggle switch selects horizontal spacing of either 10 or 12 characters per inch. If optional horizontal spacing (see 3.5.3) has been employed, this switch is non-functional until after a Clear operation is performed. |
| AUTO LF | When this switch is on, each carriage return also causes a line feed (paper moves up one line). When off, the carriage return merely moves the carriage back to the left margin, but the print head stays at the same line: a separate Line Feed operation is required to move the paper. |
| PARITY | This is a three-position toggle switch that selects the method of parity checking to be used on each incoming character, and the method of parity-bit generation to be used on transmitted characters. Parity is not checked in MARK position. |
| DUPLEX | This two-position switch selects half- or full-duplex data communications. In half-duplex, keyboard data is both transmitted and automatically printed on the printer. In full-duplex, keyboard data is transmitted only: it will be printed only if "echoed" back by the host computer. In full-duplex, the only data printed is that received over the communications link. |
| | NOTE <i>When the optional current-loop interface is used, this switch must always be in the FULL position, regardless of the mode of operation.</i> |
| CLEAR | This pushbutton provides a general reset of the HyTerm electronics. This function is also accomplished at power-on. |

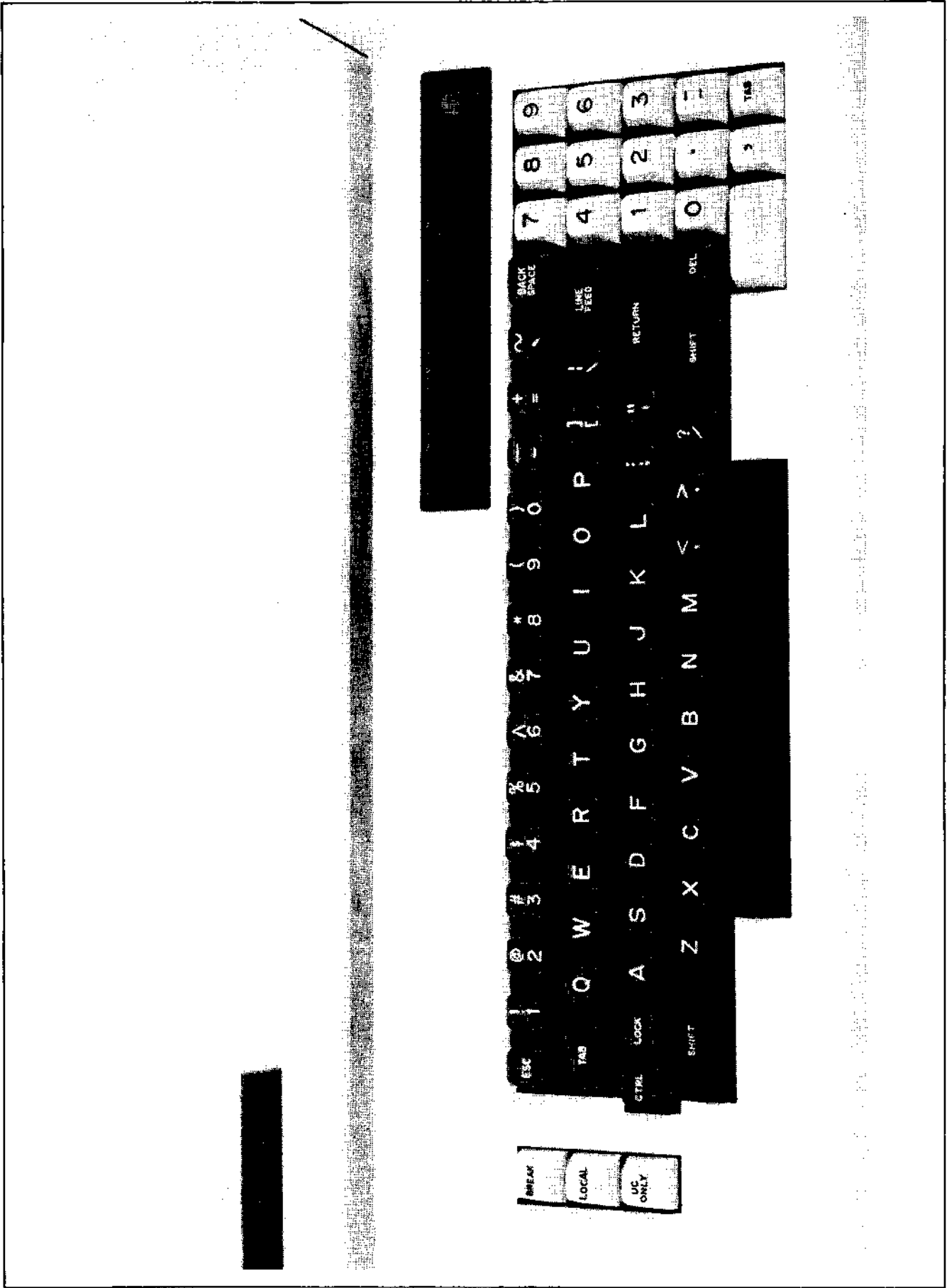

Figure 2-4. 46-Key Typewriter Pairing Keyboard

2.2.3 Keyboard

Several different types of keyboards are available to meet many different customer requirements. This section explains a typical keyboard (Figure 2-4), and the information contained here can be transferred to other keyboards with little difficulty.

The keyboard contains three sections. The largest portion is the alphameric section, generally resembling an ordinary typewriter keyboard. To the right is the numeric section, which provides an alternate means of digit entry. A control section is located on the left, which contains additional control switches.

2.2.3.1 ALPHAMERIC SECTION

Most keys in the alphameric section perform the same as regular typewriter keys: when a key is depressed, the character corresponding to that key is printed, or the function (space, tab, etc.) corresponding to the key is performed. At the same time, if in Remote mode, the code representing that character is transmitted to the communications network. If the SHIFT key or the shift LOCK key is depressed, the upper case character associated with each key is printed and the corresponding code is transmitted.

2.2.3.1.1 Control Mode. In addition to the "unshifted" and "shifted" modes of operation, a third keyboard mode, called "control" mode, is available. This mode is used to generate special control characters, such as RS, US, VT, etc. These control characters are used to perform special functions such as vertical tab, absolute horizontal tab, etc. Control mode is in effect whenever the CTRL key is held down: to generate a code in control mode, depress and hold down the CTRL key and then depress and release another key in the alphameric section. For example, to generate a Vertical Tab (VT) code on the keyboard shown in Figure 2-4, hold CTRL down and operate the "K" key once. Should both the SHIFT (or LOCK) and CTRL keys be depressed at the same time, the CTRL key will override, and the control mode will prevail.

Non-alphabetic keys having only one legend engraved on them (TAB, LINE FEED, DEL, etc.) generate the same function and the same code in all three modes. Note also that it is possible to generate some codes in two different ways, e.g., RETURN and CTRL-M both generate the CR code. For a complete listing of all codes generated in the three modes for a particular keyboard, refer to the appropriate code chart in the appendix.

2.2.3.1.2 Repeat Keys. Certain keys on each keyboard are repeat keys: when depressed and held down, the function and code associated with that key will repeat (about 20 times per second) until the key is released. This includes the minus (hyphen), backspace, line feed, carriage return, period, and space.

2.2.3.1.3 Special Keys. On some keyboards, certain keys provide special functions. One of these already covered is the CTRL key. There are three others on the keyboard in Figure 2-4 worthy of special mention. These are the ESC key in the upper left, the LINE FEED key, on the right, and the DEL key, in the lower right.

The ESC key generates the "escape" character, which is transmitted but does not print. This character causes the HyTerm electronics to interpret the following one or two characters differently than they would normally be interpreted. It is used to initiate 2- and 3-character sequences, which are used to control special functions, such as Graphics, red ribbon, etc. A complete listing of these special functions may be found in Section 1.4.2, and all of them will be covered later in this section or in Section 3.

The LINE FEED key is similar to the "Index" key found on many typewriters. It transmits the LF code, and moves the paper up one line while not returning the carriage to the left margin.

The DEL key transmits the "delete" character in Remote mode (see 2.2.3.3), with no printing. In Local mode, it prints the logical NOT symbol (¬).

2.2.3.2 NUMERIC SECTION

This section provides a "10-key pad" for rapid entry of digital data. These keys may be used interchangeably with the numbered keys in the alphameric section: either keys may be used for entry of numeric data. Key No. 5 has a dimple, to provide "home" key "feel" for the operator. Operation of the SHIFT or CTRL keys generally does not affect this section.

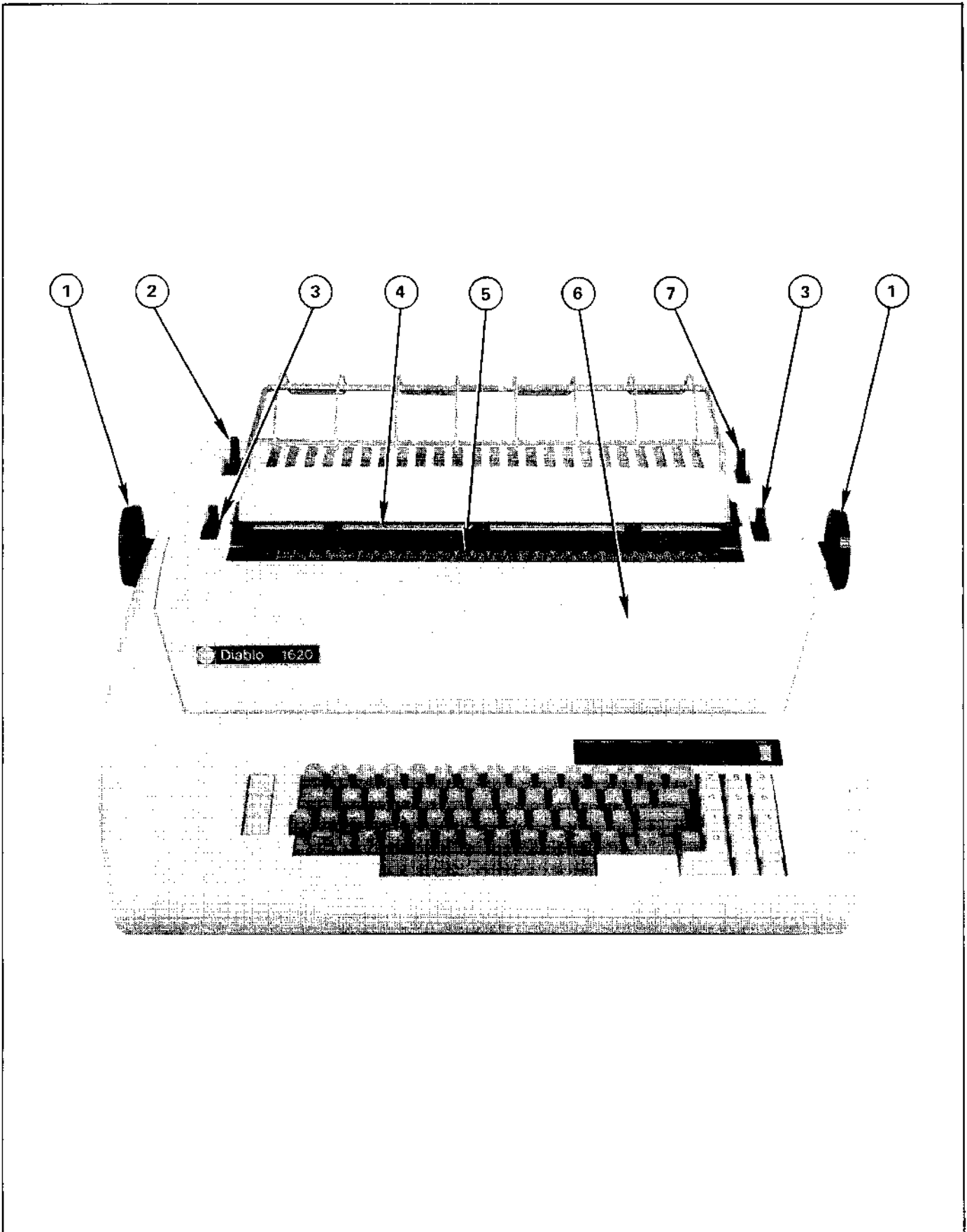

Figure 2-5. Printer Controls

2.2.3.3 CONTROL SECTION

The control section contains keys to control the following functions:

- (1) **LOCAL.** A push-to-latch/push-to-release switch that selects Local or Remote mode. In Local, the HyTerm operates substantially the same as an electric typewriter. In Remote, in addition to the typewriter functions, it also transmits and receives data over the communications link. Basic operating techniques are essentially the same in either case, with only a few additional items requiring consideration in the Remote mode. Throughout this section, when reference is made to data transmission and reception or to the communications link, it is assumed that Remote mode is in effect.
- (2) **UC ONLY (Upper Case Only).** A push-to-latch/push-to-release switch. When latched down, it converts all keyboard lower case alphabetic characters to upper case letters for printing and transmission; all non-alphabetic characters are unaffected. Incoming characters are unchanged. The OFF position inhibits this feature.
- (3) **BREAK.** A momentary action switch that transmits a Break signal to the communications link. This is normally used to "get the attention" of the host computer for various network functions. Depressing this key also clears out any data that may be left in the print buffer. (A Break is also transmitted automatically, and the print buffer is cleared, whenever a Paper Out, Printer Check, or Overrun condition occurs.)
- (2) **Platen adjust lever.** This lever moves the platen forward or backward to compensate for different form thicknesses (number of carbons). It should be all the way forward for single copies, and all the way rearward for an original and five carbon copies. Intermediate positions provide for form thicknesses between these two extremes. When printing on a form of several copies and this lever is moved toward the rear, it may be necessary to increase the print hammer intensity for optimum print quality. This is done by changing the impression control switch (see 2.2.5).
- (3) **Paper bail levers and paper bail.** The paper bail holds the paper against the platen. This is necessary for optimum print quality and quietness. The bail must be pulled forward, away from the platen, (by moving one of the levers) when paper is being inserted. When using a pin-feed platen or a tractor-feed mechanism, the bail rollers do not apply full pressure on the paper, but are held in the optimum position for proper operation by the pin-feed paper clamps or the tractor-feed mechanism.
- (5) **Combination scale.** This scale provides a visual indication of the print head position along the typing line. It is marked for both 10 characters per inch and 12 characters per inch.
- (6) **Access cover.** This cover snaps off or raises easily to provide access to the printer mechanism when it becomes necessary to replace a ribbon cartridge or change the printwheel. One of two different types of covers may be found. The first, called the "long" access cover, is a one-piece cover that is hinged at the rear and swings up when raised. The second type, called the "short" access cover, must be used with the forms tractor and is provided on all current production terminals. This cover is augmented by two plastic "skirts" that snap into place over the ends of the platen. To raise or remove the access cover, first position the carriage to the far left (either with a carriage return or by manually sliding the carriage to the left when power is OFF). Lift up on the left front corner of the access cover until it snaps free, then raise or remove the entire cover. To replace the "short" access cover, insert the right side into position first, then snap the left side into place.

2.2.4 Printer Controls

Figure 2-5 illustrates the printer controls commonly used by the operator. The numbers in the following list correspond to the keyed items in the illustration.

- (1) **Platen knobs.** These allow the platen to be rotated manually in order to insert paper and position it properly. The right-hand knob provides variable platen action — when the knob is pushed in, it allows the platen to roll freely in either direction. The position of the writing line can be changed by using this platen variable function.

Note that whenever the platen is turned by hand, the form is moved out of synchronization with the HyTerm electronics. To re-synchronize the two, the form must be positioned for printing on the first line (with the SCROLL switch off) and the SET TOP switch must be operated.
- (7) **Paper release lever.** In the forward position, this lever releases tension on the paper, allowing it to be repositioned or removed. The lever should be back when printing on a friction-feed platen to provide proper feeding of the paper. It should be forward when printing on a pin-feed platen or when a tractor-feed mechanism is used.

2.2.5 Impression Control Switch

The impression control switch (Figure 2-6) is located under the access cover, toward the right. It provides three different levels of print hammer energy to accommodate different printwheel fonts and variations in forms thickness. Set the switch as follows:

H = High intensity; for multiple part forms only.

M = Medium intensity; for most normal printing.

L = Low intensity; for lighter printing, to extend the life of the more delicate type fonts (as opposed to "Medium" or "Bold" types).

2.2.6 Cover-Open Switch

The cover-open switch is located under the printer access cover. (See Figure 2-6: the switch may be mounted differently than the one shown in the photograph, but operation is the same.) The switch is automatically actuated each time the access cover is opened or closed. If printing is attempted while the cover is open, the ERROR indicator

on the control panel lights up and the audible alarm sounds, and no printing occurs. The printing will then occur when the cover is closed again, providing the buffer did not overrun (see Table 2-3).

Occasionally it may become necessary to operate the printer with the access cover open or removed, e.g., when replacing platens or ribbons. This is permissible when done with care. This can be accomplished by pulling the switch out to its "override" position. The switch will stay in the override position until it is pushed back in, either by hand or by replacing the cover.

WARNING

Whenever the access cover is removed (e.g., when changing ribbons or printwheels), use care to not accidentally touch the cover-open switch — this could allow a sudden carriage movement which might cause injury. Always keep hair, jewelry, etc., out of the area of the carriage and printwheel.

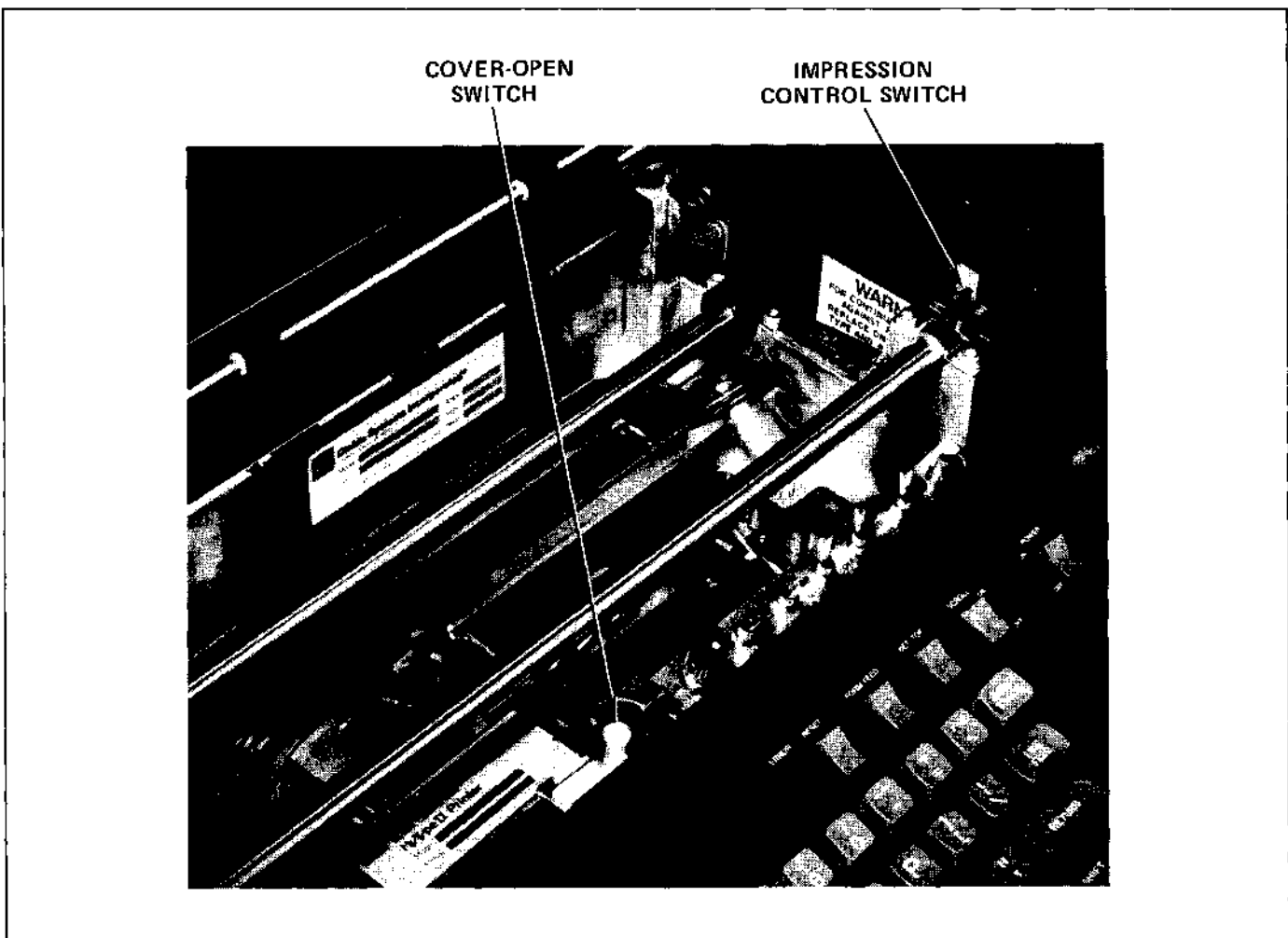

Figure 2-6. Cover-Open and Impression Control Switches

2.2.7 Paper-Out-Switch

The HyTerm is equipped with a switch that senses when the last of the continuous forms has passed through the printer. When this switch is activated and printing is attempted, the ERROR indicator on the control panel is lit, the audible alarm sounds, the print buffer is cleared (data is lost), and a "Break" is transmitted over the data link. The ERROR lamp stays on until the paper supply is replenished and the RESET switch is operated.

Many users prefer to operate the HyTerm without using this feature. Also, false paper-out indications can appear when the proper operating constraints are not followed. Because of this, the paper-out switch on top-feed printers has been disabled at the factory. Bottom-feed printers provide an override switch (on the left end of the front carriage rail, opposite the Impression Control switch) to allow for occasional insertion of paper from the top, so the paper-out switch is not disabled on bottom-feed printers.

Most users will prefer to operate the top-feed HyTerm as is, with the paper-out feature disabled. Some users, however, require this feature — it is essential for example, when the HyTerm operates unattended. If you wish to restore normal operation of the paper-out switch, perform the following operations. (Refer to Figure 2-6a.)

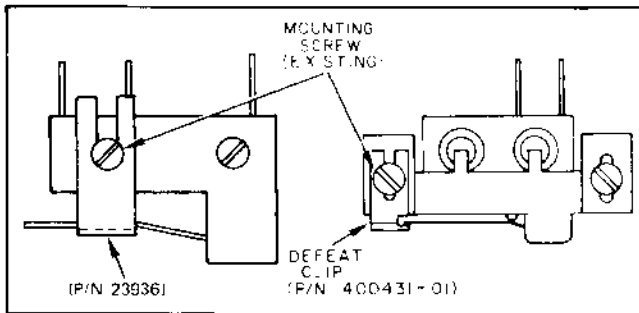

Figure 2-6a. Paper-Out Switch Clip

- (1) Raise the access cover. Remove the platen. Remove the top cover. If needed, refer to Section 2.4.3.1 for platen removal instructions. Top cover removal is outlined in Section 5.5.2.
- (2) Locate the paper-out switch just behind the platen near the left end. Loosen the left-hand switch mounting screw and remove the locking clip. Tighten the screw. Be careful not to alter the position of the switch or to bend the switch operating arm. (If desired, the locking clip can be left mounted under the screw, and simply rotated to the side to allow the switch to operate normally. This is advisable if there is a chance you may want to reinstall the clip at a later date.)
- (3) Replace the top cover, the platen, and the access cover. Check the switch for proper operation according to the following operating constraints:
 - (a) The paper-out feature is operational only when a pin-feed platen or a forms tractor is used, when the paper release lever is in its forward position. When the paper release lever is in its

rearward position (pressure applied to paper), no paper-out condition will be sensed.

- (b) The supply of continuous forms must rest on the floor behind the HyTerm, and the forms should be pulled up at least three feet as they are drawn into the printer. This is necessary to maintain sufficient pressure on the forms to prevent a false paper-out situation. Do NOT maintain the forms supply on the desk or other surface on which the HyTerm is placed. The forms must have full contact on the paper rack fastened to the top cover of the HyTerm.

- (4) If paper-out problems exist even though the above items are observed, check the adjustment of the switch as outlined in Section 3 of the maintenance manual (#82333).

Note that bottom-feed printers have only one paper-out switch — that for bottom-fed paper. There is no paper-out sensing capability for paper fed from the top.

2.3 BASIC OPERATING PROCEDURES

Specific operating procedures are dictated by the particular application in which the terminal is used. There are, however, some basic procedures that are common to most applications. These include paper handling techniques, establishing the data link, and error recovery.

CAUTION

Keep papers, books, and other desk top items that might impede airflow at least six inches (15 cm) away from the HyTerm on all sides. Also, provide at least six inches clearance between the HyTerm and adjacent walls.

2.3.1 Turn-On

When the POWER switch is turned on, the HyTerm automatically performs a Clear operation and is ready for operation. However, unless the terminal is ready to communicate over the data link (paper loaded, all switches in the proper position, etc.) it is recommended the LOCAL switch be latched down first. Then power can be safely applied without inserting an error into the network. Leave the terminal in Local until the paper is loaded, all switches are set properly, and the data link is established between the modem and the host computer.

2.3.2 Loading Paper

The procedure for loading paper is different for top-feed or bottom-feed printers. If the form being installed is shorter or longer than the previous form used, adjust the FORM LENGTH switch. Use the one of the two following procedures that applies. Before positioning the paper be certain the SCROLL switch is off. After positioning the paper, depress the SET TOF switch.

2.3.2.1 TOP-FEED PRINTER

This procedure is the same as for a regular typewriter, although it varies slightly when a pin-feed platen or a forms tractor is used.

2.3.2.1.1 Standard (Friction-Feed) Platen. Load paper in a printer having a friction-feed platen as follows:

- (1) Make sure the paper release lever is back (to put pressure on paper).
- (2) Pull the paper bail away from the platen.
- (3) Holding the paper aligned horizontally to provide the desired margins, insert it into the printer behind the platen.
- (4) Roll the paper into the printer until it is approximately 1/2 inch above the card guide (the shield between the ribbon and the paper).
- (5) Push the paper bail back — the rollers should ride on the paper.
- (6) Position the paper for the first line of printing. Push the right-hand platen knob in and rotate it if fine positioning is necessary.

2.3.2.1.2 Pin-Feed Platen. Use the following procedure for inserting continuous forms, having holes punched on both sides on 1/2 inch centers:

- (1) Pull the paper release lever forward. This is the normal operating position when a pin-feed platen is used.
- (2) Pull the paper bail forward, away from the platen.
- (3) Release both pin-feed paper clamps.
- (4) Insert the paper into the printer behind the platen. Push the paper through until the leading edge can be grasped coming up in front of the platen. Pull the paper through until it is approximately 4-6 inches above the typing line.
- (5) Align one set of holes in the form (either side) with the pins in the platen, and snap down the paper clamp.
- (6) Straighten the paper by aligning the edges of the portion in front of the platen with the edges of the portion behind the platen.
- (7) Snap down the second paper clamp.
- (8) Position the paper bail back against the paper clamps.
- (9) Position the paper for the first line of printing. Push the right-hand platen knob in and rotate it if fine positioning is necessary.
- (10) Depress the SET TOF switch.

NOTE

When using a pin-feed platen, the paper release lever must be in its forward position, removing pressure from the paper. If the lever is pushed back, improper paper feeding and tearing of the paper will result.

Occasional sheets of paper narrow enough to fit between the two sets of pins can be inserted if the pin-feed clamps are lifted up and the paper release lever is pushed back (to put pressure on the paper). In this case, the paper is inserted the same as for the standard friction-feed platen, and lifting the paper clamps out of the way allows the paper bail to swing all the way back, so that the rollers rest on the paper.

2.3.2.1.3 Tractor Feed Assembly. The tractor-feed

assembly requires the use of continuous forms with feed holes (on 1/2 inch centers) punched on both sides of the form. If non-standard forms or individual sheets are to be used, the tractor-feed mechanism should be removed.

- (1) Pull the paper bail forward, away from the platen.
- (2) Release both tractor feed paper clamps.
- (3) Tip the outfeed (top) paper support up and forward until it rests in the forward position. This restores tension on the paper feed rollers so that turning the platen will pull the paper through the printer.
- (4) Insert the first of the continuous forms into the printer, over the infeed (lower) paper support, and down behind the platen. Turn the paper through until the leading edge is several inches above the card guide.
- (5) Tip the outfeed paper support back down to its at-rest position. This releases tension on the paper feed rollers so the paper can be pulled freely through the printer.
- (6) Pull the paper through until it is approximately 6-8 inches above the typing line.
- (7) Place the form over the teeth on the left-hand tractor assembly and close the clamp.
- (8) Align the form, place it over the teeth on the right-hand tractor assembly, and close the clamp. If necessary, adjust for proper form width by loosening the right-hand tractor clamp screw and sliding the right-hand tractor to either side. Then retighten the clamp screw.
- (9) Push the paper bail back against the tractor feed.
- (10) Position the form for the first line of typing: turn the paper up — the first of the continuous forms is used only to get the forms started through the tractor-feed and it cannot be used for printing. Push the right-hand platen knob in and rotate it if fine positioning is necessary.
- (11) Depress the SET TOF switch.
- (12) Horizontal positioning of the form can be accomplished by loosening the tractor clamp screws, repositioning the tractors, and tightening the screws. This should be done with the forms already installed in the tractors.

The tractor-feed pulls the forms through the printer mechanism, but it cannot "push" them back through in the other direction. If it becomes necessary to roll the forms backward (down) more than just a few lines, reach behind the printer and pull the forms back through while turning the platen. This will keep the forms from bunching up and jamming in the printer.

2.3.2.2 BOTTOM-FEED PRINTER

The bottom-feed printer uses only continuous forms, and requires a forms tractor to pull the forms through. Be certain the curved paper cradle (deflector) under the platen has been removed; the paper will not feed properly from the bottom if this cradle is left installed. This cradle may be reinstalled at any time to allow normal top-feed paper use.

- (1) Pull the paper bail forward, away from the platen.
- (2) Release both tractor-feed paper clamps.

- (3) Insert the leading edge of the continuous forms through the slot in the bottom of the printer into the forms chute. Push the forms up until the leading edge protrudes far enough to be pulled from the top.

NOTE

To provide easier paper insertion, fold the leading edge of the continuous forms diagonally, insert the "point" into the forms chute, and push it up.

- (4) Pull the form up and position it over the pins on the tractor feed. Snap down the clamps on one side, align the form, and snap down the other clamp.
- (5) Push the paper bail back against the forms tractor.
- (6) Position the paper for the first line of printing.
- (7) Depress the SET TOF switch.

NOTE

Negative paper movement is not recommended when the bottom-feed mechanism is used.

2.3.3 Establishing the Data Communications Link

The data communications link includes the HyTerm, two "modems" (modulator/demodulators), the host computer or remote terminal, and the telephone lines between the modems. The modems perform the function of changing the digital signals used by the HyTerm and the host computer into audio signals capable of being transmitted and received over the telephone lines.

The specific procedure needed to establish the data communications link between the HyTerm and the host computer is dependent upon the type of modem being used and upon network characteristics. In every case, it is necessary to know the basic operating characteristics of the host computer or remote terminal, such as its data transmission speed (baud rate), the type of data transmission being used (half- or full-duplex), the type of parity in use, whether upper case letters are required, and if the host computer is set up to transmit a line feed with each carriage return. When these factors are known, the control switches can be set accordingly, and the communications link can be completed. All control switches other than the SPACING switch should be set prior to establishing the communications link: it may or may not be necessary to set the SPACING switch, depending upon network characteristics.

If a leased phone line is used, the link is always established and it is necessary only to apply power to the HyTerm and release the LOCAL switch. In dial-up configurations, the data link is normally established after the HyTerm is powered up and made fully ready (forms installed, all control switches set, etc.). Once the link is established it is then only necessary to release the LOCAL key to enter Remote mode and begin data communications.

The procedure in establishing the data link is dependent upon which end of the link originates the call. General procedures are given here to familiarize the operator with some of the possible situations, and to relate the HyTerm to the modem operating steps. However, specific instructions for the particular modem being used should always be carefully observed.

NOTE

A typical computer network usually requires establishment of a data communications link within 30 seconds after the answer tone from the computer begins. If the data link is not completed in time, the host computer may disconnect the call and the connection procedure must be performed again.

2.3.3.1 ORIGINATING A DATA LINK WITH AN ACOUSTIC COUPLER

Before actually establishing the data link, perform the following preliminary steps:

- (1) Determine the correct placement of the telephone receiver in the acoustic coupler: one end of the coupler is usually marked "cord", or has some similar identification. (Do not place the phone in the acoustic coupler yet — leave it "on hook" for now.)
- (2) Make sure the LOCAL key is depressed, all control switches are set correctly, and power is on.
- (3) Insert the correct paper or forms into the HyTerm.
- (4) Make sure the acoustic coupler power is on.

After these preliminary steps have been completed, establish the link as follows:

- (1) Pick up the telephone receiver and dial the host computer.
- (2) When the host computer sends its "answer-back" tone, quickly place the telephone receiver firmly into the acoustic cups on the coupler. (If voice communication occurs prior to establishing the link, the person at the other end of the link must place his modem in the DATA mode before the telephone receiver at the HyTerm end is placed into the acoustic coupler.)
- (3) After a second or two the "carrier" indicator on the acoustic coupler should illuminate. If it does not light, something has gone wrong and the procedure will probably have to be repeated.
- (4) Release the LOCAL key on the keyboard. This puts the HyTerm into Remote mode. If the ERROR indicator is illuminated, press the Error RESET switch to extinguish it. If it comes back on, an error exists that must be corrected before data communications can take place. Refer to the Error Handling Procedure in Section 2.3.4.

When the data communication is complete, the link can be disconnected by simply removing the receiver from the acoustic coupler and placing it back on the telephone cradle. (The link can also be disconnected by the host computer at any time.)

2.3.3.2 ORIGINATING A DATA LINK WITH A BELL-TYPE MODEM

There are several different types of Bell-type modems that can be used with the terminal but the operation of most of them is essentially the same. (See information about "originate only" modems in the next section, 2.3.3.3, if applicable.) Proceed as follows:

- (1) Make sure the LOCAL key is depressed, all control switches are set correctly, and power is on.
- (2) Insert the correct paper or forms into the HyTerm.
- (3) Pick up the telephone receiver and depress the TALK button (which will light, on most modems).
- (4) Dial the host computer. When it responds with its "answer-back" tone, depress the DATA button on the modem, and then place the receiver back on its cradle. On most modems, the TALK light will go out and the DATA light will turn on. (If voice communication precedes the establishment of the data link, the attendant at the host computer must place his modem in the DATA mode first.)

NOTE

The DATA button must be depressed before hanging up the phone receiver: if the receiver is placed on the cradle while the TALK button is depressed, the link will be disconnected.

- (5) Release the LOCAL key on the keyboard. If the ERROR indicator is illuminated, depress the Error RESET switch to extinguish it. If it comes back on, an error exists that must be corrected before data communications can take place. Refer to the Error Handling Procedure in Section 2.3.4.

When the data communications are finished, the link can be disconnected by simply depressing the modem TALK button. The link can also be disconnected at any time by the host computer.

2.3.3.3 ORIGINATE-ONLY MODEMS

Originate-only modems, such as the Bell type 113A, can be used to communicate with a host computer using the preceding instructions. An originate-only modem can also be used to communicate with another remote terminal, but only if the remote terminal does not have an originate-only modem. When one of the terminals has an originate-only modem, it must initiate the call, and the other terminal must go into the data mode first, to supply the "answer-back" tone.

2.3.3.4 ANSWERING A DATA LINK CALL

Answering a call may be automatic, or it may require operator intervention. With many modems, simply leaving the receiver "on hook" and leaving the DATA button depressed will allow any incoming calls to be "answered" automatically, and the data link will be established.

In many cases it is desirable to carry on voice communication before entering the data mode. When this occurs, it is only necessary to be sure that the person at the answering end of the link places his modem in the DATA mode first.

Some modems do not have receivers, or "handsets": in this case neither voice communication nor call origination is possible, but answering is automatic. Other modems may have a separate, complete telephone connected to them. In all cases, follow the instructions pertaining to the particular modem being used.

2.3.4 Error Recovery

Some error-recovery procedures are application-dependent, and cannot be covered here. The general procedures to be followed if errors should occur are shown in Table 2-3.

Certain general practices should be considered during any error-recovery procedure. For example, should excessive errors occur immediately after turn-on or establishing the data link, it is likely that one or more of the control switches has been set wrong. Check the SPEED, PARITY, and other switches to make certain they are set properly. If several errors occur simultaneously, often one type of error causes others to occur, and rectifying one will solve the others as well. If the remedial actions given in the table do not rectify the troubles, depress the CLEAR pushbutton, and try to begin operation again from the beginning.

2.3.5 Keyboard Control of Features

Most of the standard and special features of the terminal can be controlled by either the operator or the host computer. Several functions are rarely used by the operator, and so will not be covered here; information on these items is contained in Section 3, Functional Description.

Those features under control of the front panel and control panel switches have already been explained; see Section 2.2 for information on these features. Margins, tabs, and other operating parameters should be set in Local mode, before going "on line" to the host computer, unless dictated otherwise by network characteristics.

Table 2-3. Error Recovery

| Error Indication | Possible Causes | Remedial Action |
|---|----------------------------|---|
| Audible | 1. Parity or Framing Error | Locate erroneous character(s), represented by '—' symbol. Decide whether correct character can be ascertained from surrounding text. If errors are excessive, check settings of SPEED and PARITY switches. Depress RESET switch to extinguish indicator. Request retransmission if necessary. |
| Alarm | 2. Paper Out* | Revert to Local mode. If SCROLL switch is on, turn it off and space once. Insert and position new forms, depress SET TOF once, and return to Remote mode. Turn SCROLL switch back on, if necessary. Depress RESET switch to extinguish indicator. Request retransmission. |
| Sounds, ERROR | 3. Printer Check* | Depress CLEAR to extinguish indicator and restore printer carriage. If necessary, enter Local mode and set tab stops, margins, etc., as needed; then return to Remote mode. Request retransmission. |
| Lamp | 4. Cover Open | Close printer access cover. Depress RESET to extinguish indicator. |
| Lit | 5. Overrun Error* | Depress RESET switch to extinguish indicator. Request retransmission if necessary. |
| | 6. "Break" Received | Perform steps predefined by the network for this situation. |
| Audible Alarm Sounds, ERROR Lamp Not Lit | 1. Right Margin Exceeded | Check setting of right margin, readjust and/or request retransmission if necessary. |
| | 2. BEL code Received | Perform steps dictated by network for this situation. |

NOTES:

- * Automatically clears print buffer and sends "Break" to host computer.
- 1. Remedial actions listed are general in nature and may be replaced or modified by specific procedures dictated by network requirements.
- 2. "Requesting retransmission" usually involves depressing the BREAK key, but additional steps, such as repositioning forms in the printer, depressing the SET TOF key, and/or other operations may also be dictated by network requirements.
- 3. After depressing CLEAR, additional steps such as setting margins and tab stops, etc., may be required depending upon network characteristics.

2.3.5.1 MARGINS (ESC 9, ESC 0)

When power is first applied, or when a CLEAR operation is performed, both the right and left margins are set to their maximum outward positions. To change either margin, first position the carriage to the desired new margin location. Then depress the ESC key, followed by the 9 key to change the left margin or the 0 (zero) key to change the right margin. If a second change is desired, the first setting need not be cancelled: setting a new margin automatically cancels the old one.

Once the left margin has been changed, subsequent carriage returns will return the carriage to the new position. Backspacing is permitted past the new left margin, but never beyond the "extreme" left margin position (print position 1).

Once the right margin has been changed, printing can continue past the new margin, but as the carriage passes the new setting, the audible alarm sounds. The keyboard is not disabled. Printing can continue past the right margin all the way to the "extreme" right margin position (same position as right margin after CLEAR operation), at which point any further characters will be overprinted on the characters previously printed there.

2.3.5.2 CARRIAGE MOVEMENT

Normal carriage movement is accomplished as a result of printing each character. The SPACE and BACKSPACE keys cause the same operation as on a regular typewriter. They are usually repeat keys, which will cause repeated spacing or backspacing if they are held depressed. The RETURN key always causes the carriage to return to the left margin, but it does not move the paper unless the AUTO LF switch is on.

The TAB key causes the carriage to move to the right to the next previously-set tab stop. If there are no tab stops set to the right of the present carriage position, operating the TAB key causes the carriage to move to the extreme right print position (print position 132 for 10 characters per inch and print position 158 for 12 characters per inch).

To set tab stops, first space the carriage to the desired tab stop position. Then depress the ESC key followed by the digit 1. For normal 10-pitch or 12-pitch spacing, there are no restrictions as to the number of tab stops or to the distance between stops.

To clear individual tab stops, first tab to the stop to be cleared, and then depress the ESC key followed by the digit 8. To clear all tab stops at once, depress the ESC key followed by the digit 2.

See Section 3 for information on Absolute tabbing.

2.3.5.3 PAPER MOVEMENT

There are several functions that affect paper movement. These include line feed, negative line feed, form feed, and vertical tab. Vertical tab is covered in Section 3.

To accomplish a normal line feed, depress the LINE FEED key. A normal line feed also occurs as a result of a carriage return when the AUTO LF switch is on.

To perform a negative line feed (to move the paper down one line), depress the ESC key before operating the LINE FEED key.

To perform a half-line feed (to move the paper up 1/2 line), depress the ESC key followed by the upper case "U" key. This is used for typing subscripts or to return to the original line after performing a negative half-line feed.

To perform a negative half-line feed (to move the paper down 1/2 line), depress the ESC key followed by the upper case "D" key. This is used for typing superscripts and exponents or to return to the original line after performing a half-line feed.

For both half-line feed operations, make sure to use the respective upper case (capital) letters; the lower case characters will have no effect.

A form feed can be accomplished in either of two ways. As previously explained, the form will be moved up to the top line of the next form when the FORM FEED switch on the front panel is operated. This same action can also be initiated from most keyboards by producing the FF code. This is normally done by holding down the CTRL key while operating another key, usually the "L." Note, however, that when this method is used in Remote mode, the FF code is transmitted to the communications network. If a form feed is desired without transmitting the FF code, the front panel FORM FEED switch must be used.

2.3.5.4 RIBBON CONTROL

The HyTerm is initialized for printing in black. To change to red, execute the 2-character sequence ESC A. To change back to black, execute ESC B. Make sure to use the upper case A and B characters — the lower case "a" and "b" will have no effect. A CLEAR operation will also restore black printing.

The choice of red or black can also be controlled remotely by the host computer. If the host computer is to attempt red printing, be certain to have a two-color ribbon installed: if red printing is attempted on a single-color ribbon, the ribbon will not be lifted into position for printing, and printing will occur only as long as sufficient ink remains on the printwheel type face.

2.4 OPERATOR DUTIES

There are certain operator duties that must be performed routinely, such as replacing ribbons. However, few operators will perform all of the items covered here. These special duties need be performed only as the need arises.

CAUTION

Be extremely careful in the handling of beverages and other liquids, and small metal objects, such as paper clips and staples, near the HyTerm. Should any metal objects be dropped into the machine, or any liquids spilled on it, do not attempt to use it; severe damage to the electronic circuits could result. Immediately unplug the power cord from the wall. After the cord is unplugged, metal objects may be removed if they can be located. If they cannot be found, or if a liquid has been spilled, have maintenance personnel clean and inspect the interior of the unit before attempting to use it.

The HyTerm printer is electronically controlled and has few moving parts. Because of this, it will provide exceptionally trouble-free operation for long periods of time. The operator can help to extend these trouble-free periods by exercising reasonable care in the handling of food, beverages, and other possibly-contaminating materials around the printer.

For the operator's own safety, dangling jewelry should not be worn when operating the HyTerm — it could get caught by the printer carriage and inflict minor injury. Heed the warning label on the base of the printer, in the area underneath the carriage.

2.4.1 Replacing Ribbon Cartridge

WARNING

Be careful not to accidentally operate the cover-open switch.

- (1) Raise or remove the printer access cover [see 2.2.4(6)].
- (2) Depress both ribbon clamps (Figure 2-7), and lift the old ribbon straight up.
- (3) Remove the new cartridge from its container. Turn the small ribbon advance knob (Figure 2-8) in the direction indicated by the arrow, enough to remove all slack from the ribbon.
- (4) Holding the new cartridge with the DIABLO name on top, guide the ribbon around the two metal ribbon guides (Figure 2-9) and down between the printwheel and the card guide. Then push the cartridge down until the ribbon clamps snap into position to hold it in place.
- (5) Replace the access cover.

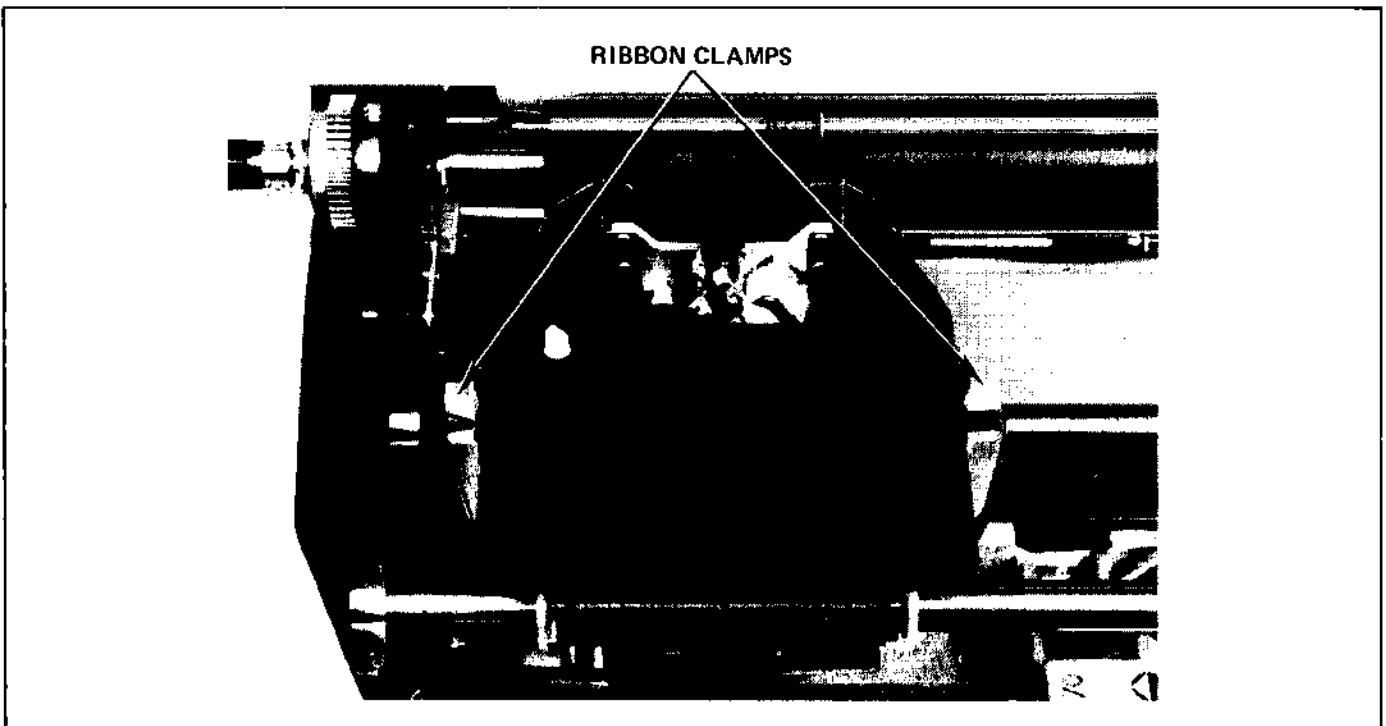

Figure 2-7. Ribbon Clamps

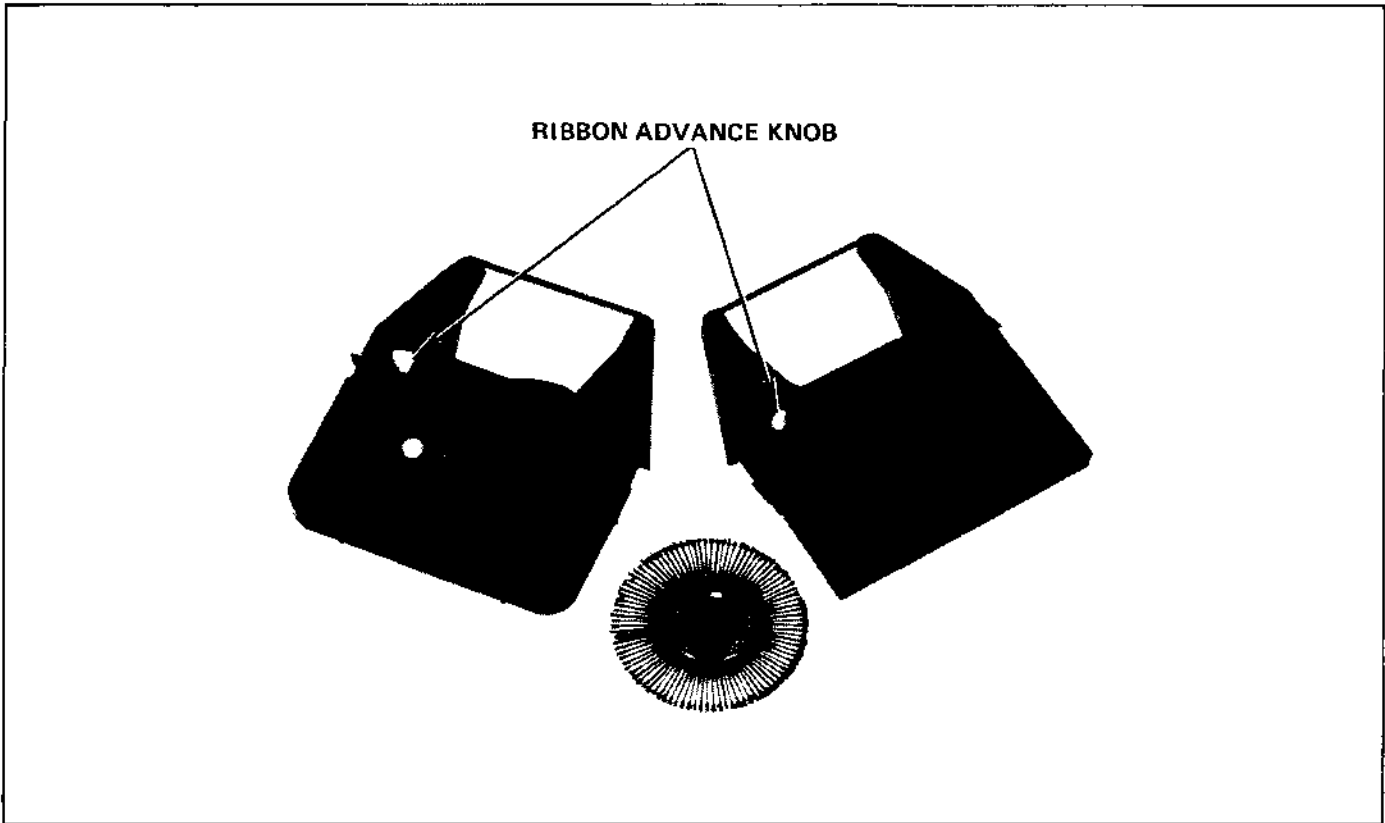

Figure 2-8. Ribbon Advance Knob

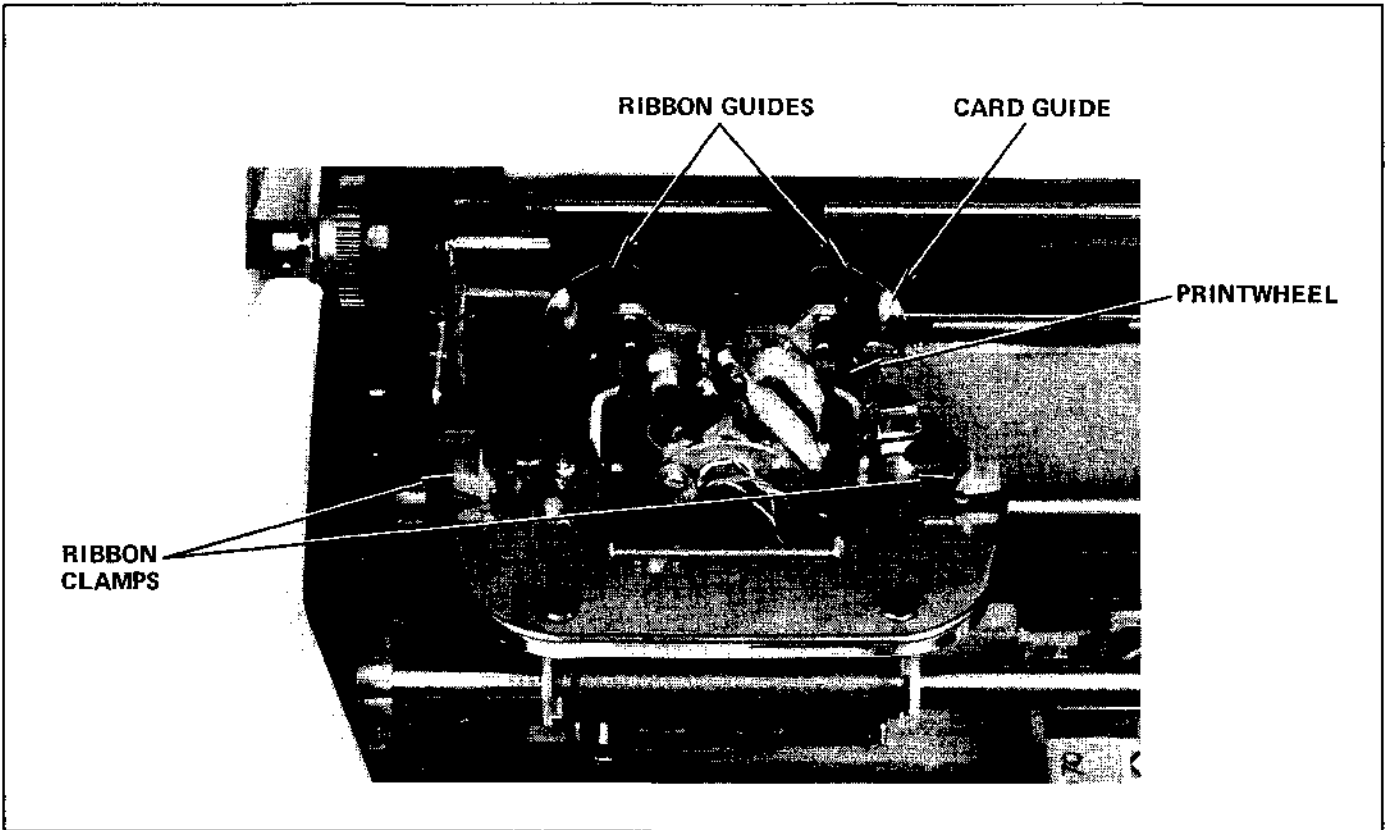

Figure 2-9. Ribbon Cartridge Placement

2.4.2 Changing Printwheels

NOTE

It is recommended that the power be turned off whenever replacing printwheels. If a printwheel must be replaced with the power on, be careful not to brush the cover-open switch or to accidentally operate it in any way — this could allow a sudden carriage movement which might inflict injury.

- (1) Raise or remove the access cover [see 2.2.4(6)].
- (2) Remove the ribbon cartridge (see 2.4.1).
- (3) Pull the carriage toward you, away from the platen. It will snap into the position shown in Figure 2-10.
- (4) Remove the printwheel by pulling on the rubber knob at the printwheel hub (Figure 2-10). Place the printwheel in its protective case.
- (5) Remove the new printwheel from its case and position it over the printwheel shaft (Figure 2-11), rotating the wheel until its alignment hole (Figure 2-12) is lined up with the shaft's alignment tab (Figure 2-11).
- (6) Press the hub of the wheel firmly to lock it in place.
- (7) Push the carriage back into position for printing. It will snap into place.
- (8) Replace the ribbon cartridge.
- (9) Replace the access cover.

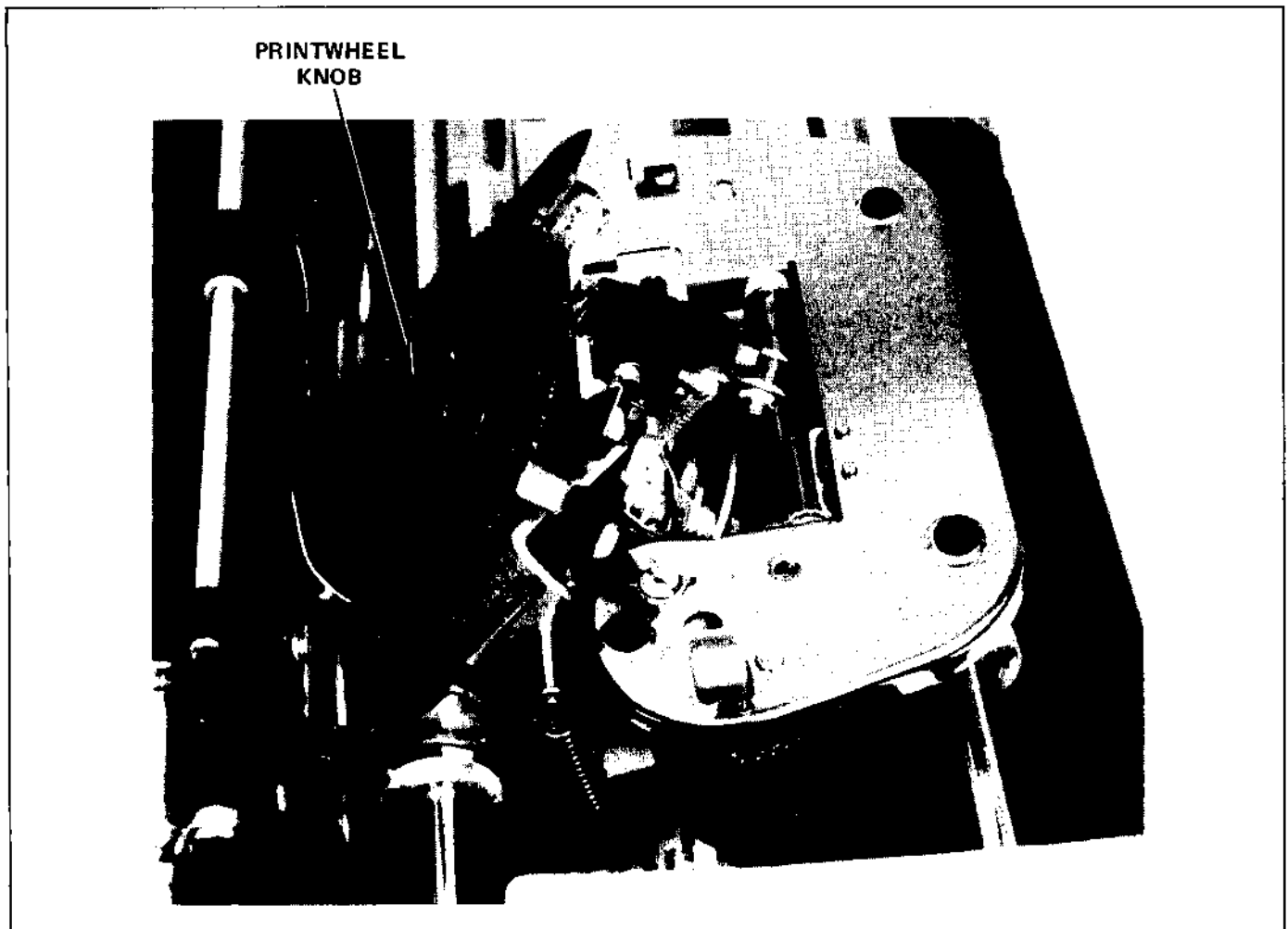

Figure 2-10. Carriage Tilted for Printwheel Access

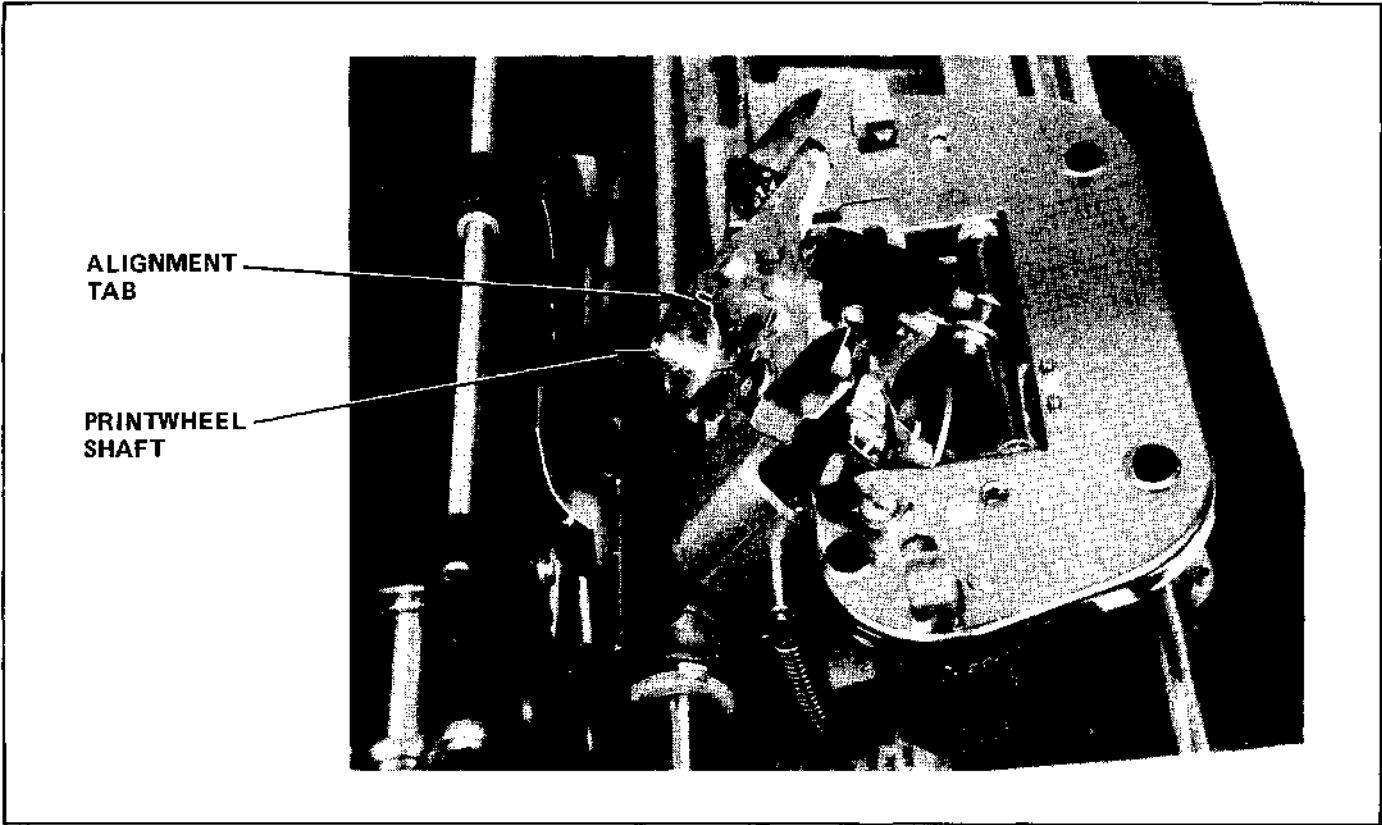

Figure 2-11. Printwheel Installation

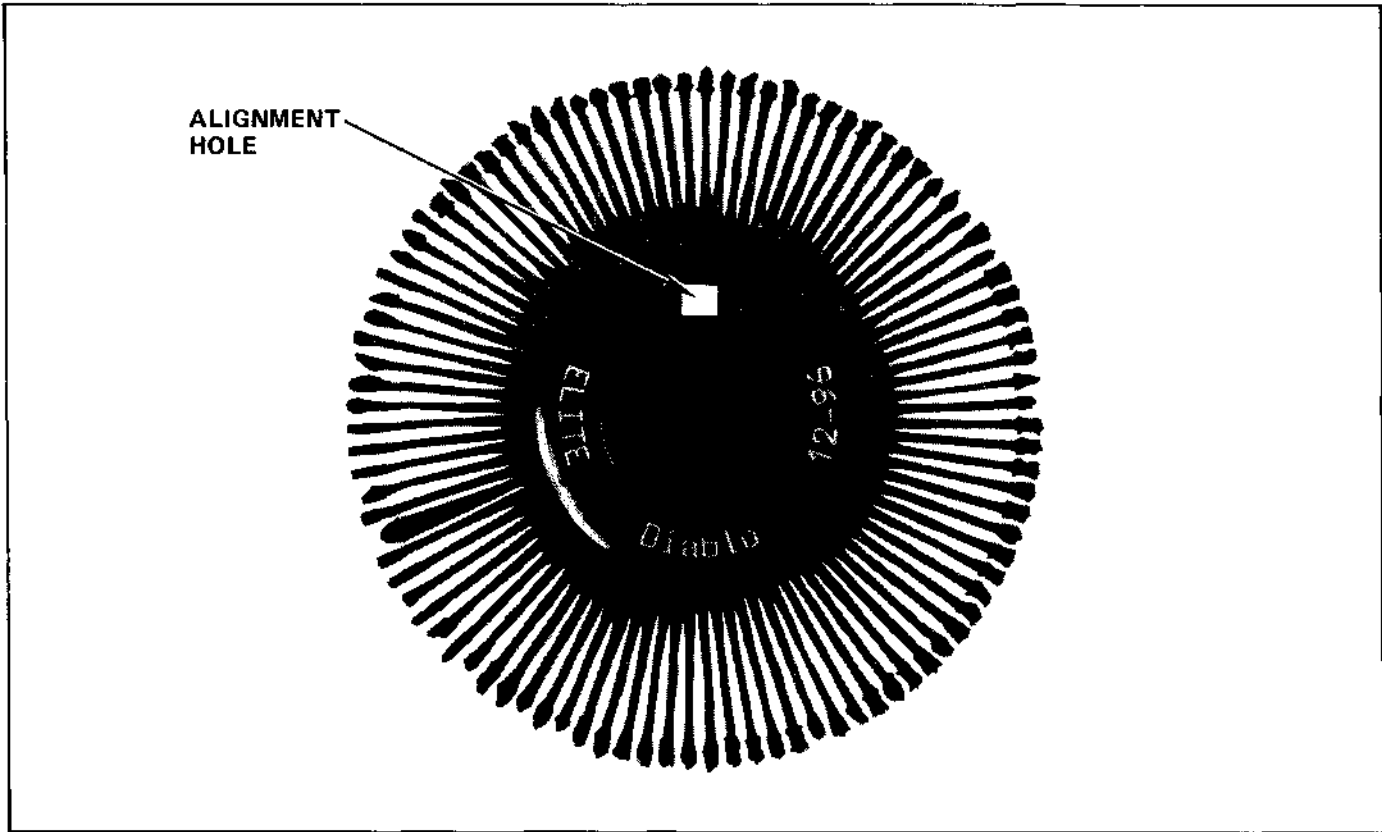

Figure 2-12. Printwheel

2.4.3 Changing Platens

Platen removal and installation is necessary only when switching from one type of platen to another. Platen removal is the same for all types; installation procedures vary between platen types.

Terminals equipped with plastic platen "skirts" over the ends of the platen must have these skirts removed before the platen can be removed. Refer to Figure 2-13 for removal instructions. Outward pressure on the lower front portion of the skirt is necessary to keep this part of the skirt from wedging against the top covers.

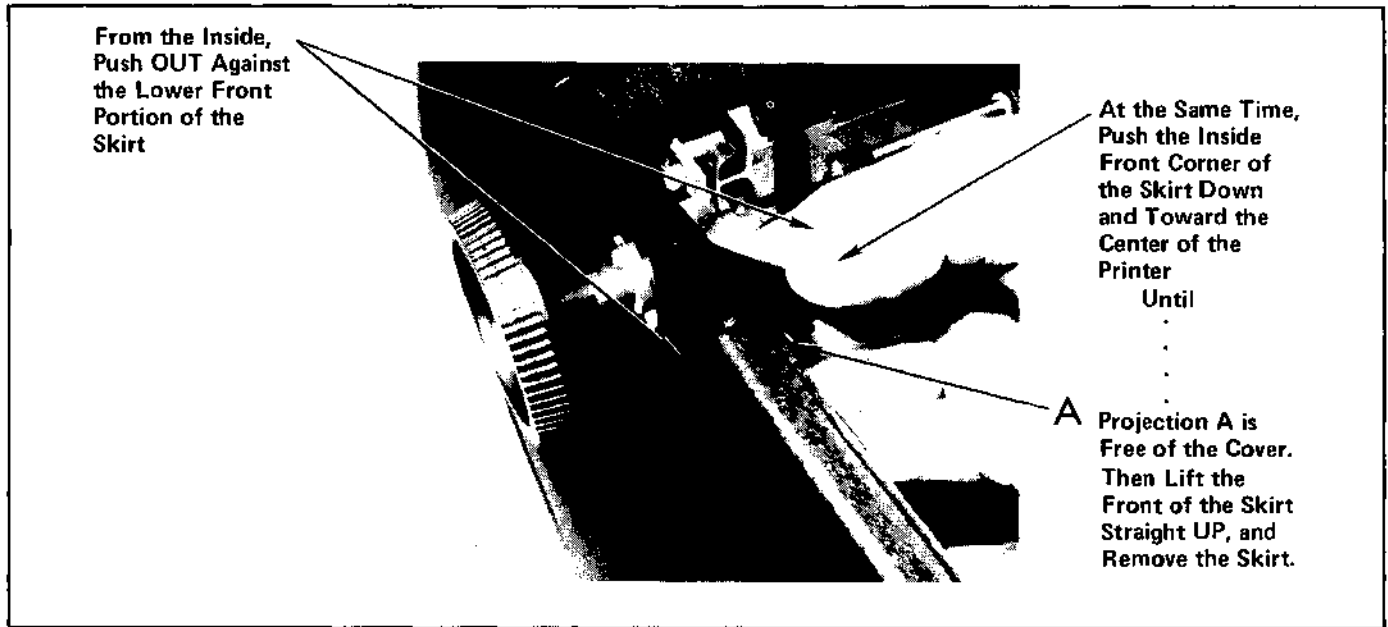

Figure 2-13. Platen Skirt Removal

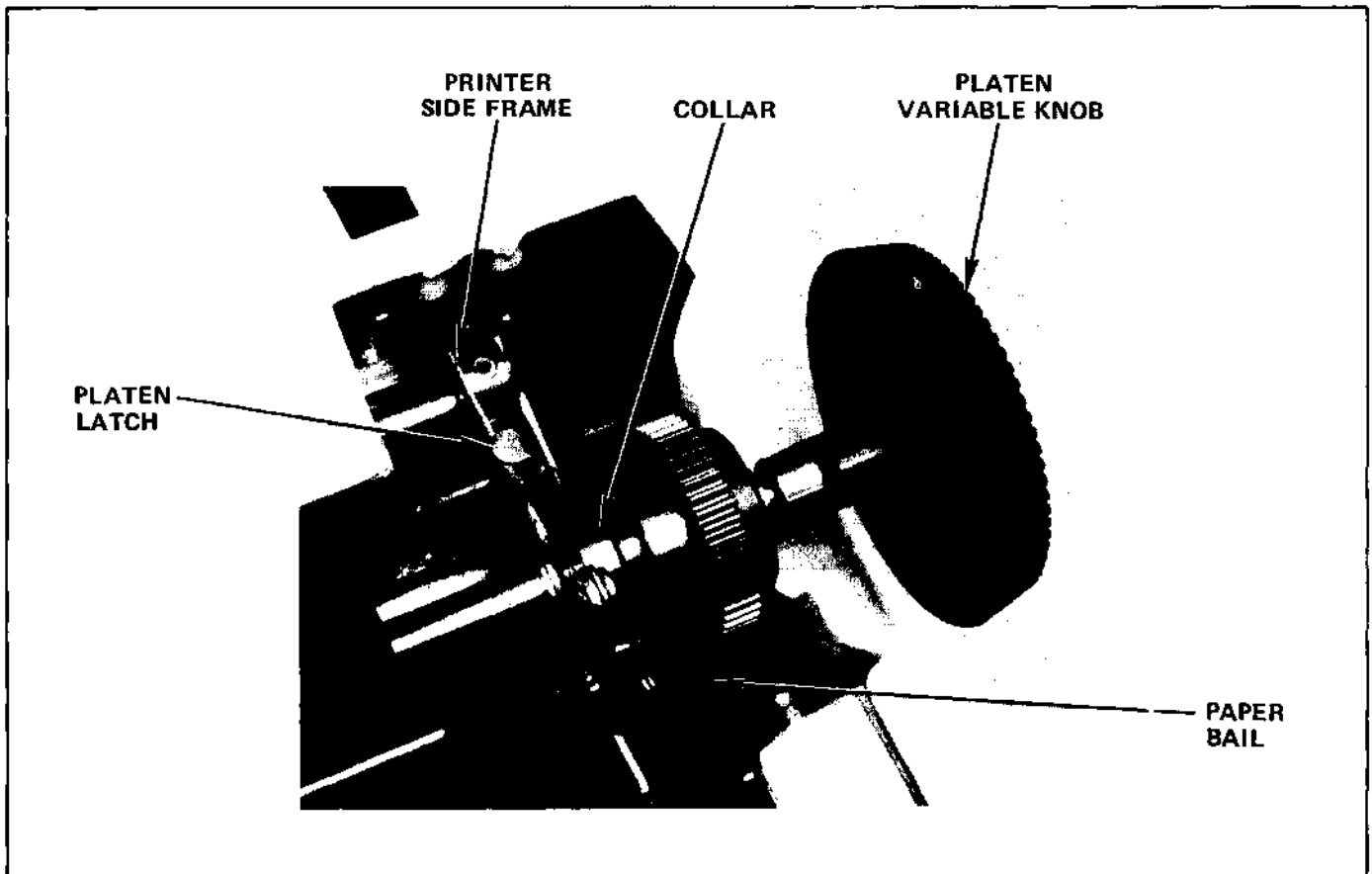

Figure 2-13a. Platen Removal

To replace the skirt, install the rear portion first, fitting the smaller of the two rear projections between the two bosses on the inside of the top cover (visible in Figure 2-13a). Lower the front of the skirt, guiding its two lower projections to the inside of the terminal top cover. When the skirt is positioned properly, the front will easily snap down into place.

NOTE

Always turn the POWER switch off before removing or installing platens.

2.4.3.1 PLATEN REMOVAL

- (1) Remove the tractor feed mechanism if one is used.
- (2) If the terminal has a "long" access cover, raise it to expose the ends of the platen. The long access cover is fastened to the top cover and cannot be fully removed. If a short access cover is provided, remove it and the two plastic platen skirts over each end of the platen (if used).
- (3) Pull the paper bail (Figure 2-13a) forward, away from the platen.

- (4) Refer to Figure 2-13a. Grasp the platen knobs in both hands, and while pressing down on the platen latches with the thumbs, lift the platen straight up out of the printer.
- (5) Set the platen aside carefully where it will not be damaged and where it cannot roll off onto the floor.

2.4.3.2 STANDARD PLATEN (FRICTION-FEED) INSTALLATION

Installation of the friction-feed platen is simply the reverse of platen removal.

- (1) Raise the printer access cover if necessary, to expose the printer side frames where the platen is to be installed.
- (2) Pull the paper bail forward.
- (3) Pick up the platen by both hands, holding the end with the platen variable knob in the right hand. (The platen variable knob can be pushed in toward the center of the platen slightly; the other knob cannot be moved.)
- (4) Refer to Figure 2-13a. Position the platen over the printer so that both collars are aligned with the printer side frames. Depress the platen latches with

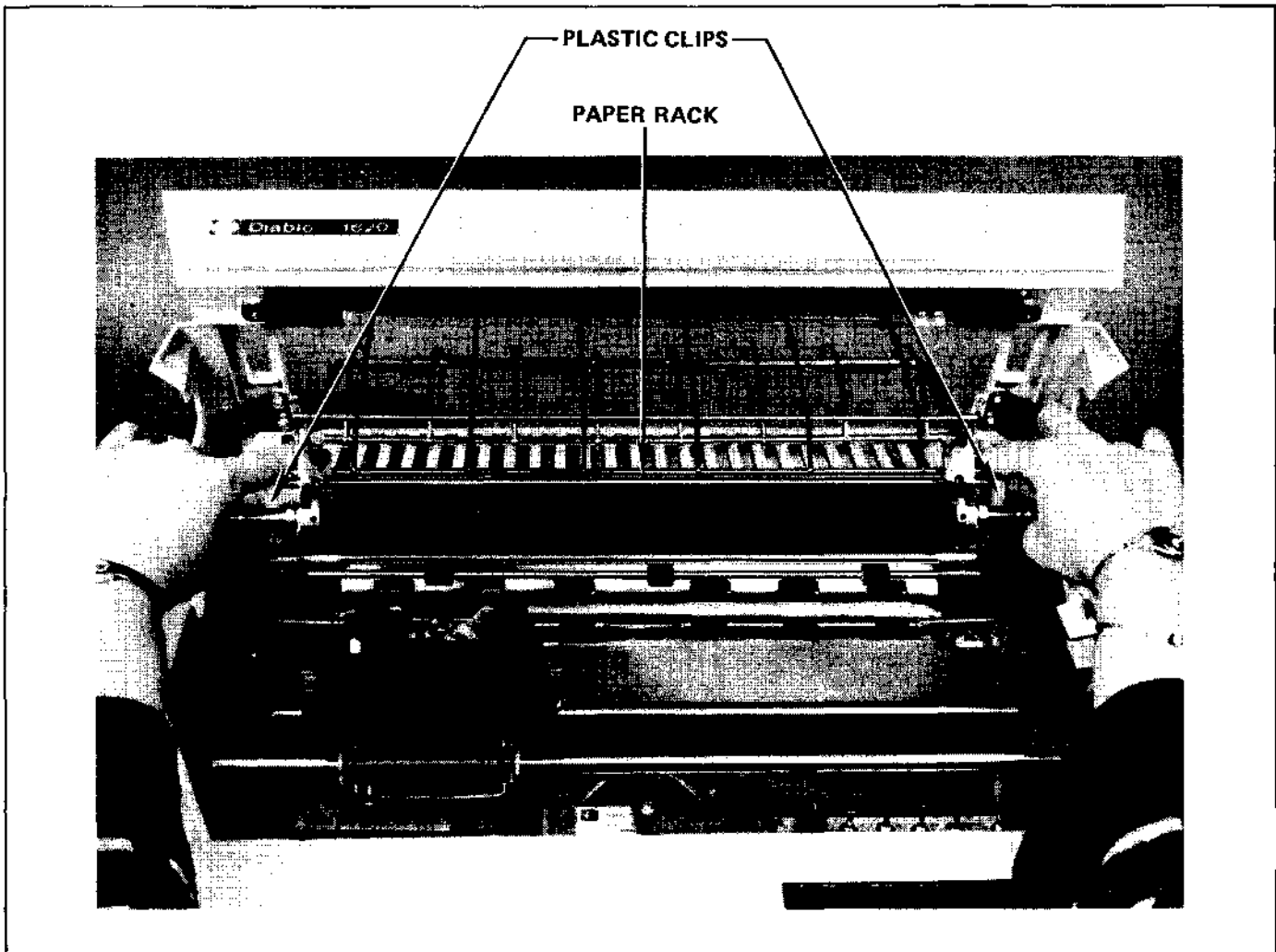

Figure 2-14. Pin-Feed Platen Installation

both thumbs and push the platen down into place. Release the latches.

- (5) Rotate the platen to be certain it is properly seated.
- (6) Close or replace the access cover and platen skirts and replace the tractor feed mechanism, as appropriate.

2.4.3.3 PIN-FEED PLATEN INSTALLATION

- (1) Lift or remove the printer access cover to expose the area of the platen.
- (2) Pull the paper bail lever and paper release lever forward toward the keyboard.
- (3) Holding the pin-feed platen in both hands, with the drive gear on the right, and with the forefingers supporting the pin feed paper clamps and the paper rack, lower the platen into the printer and position it so that the white plastic clips hang down behind the platen shaft as shown in Figure 2-14.
- (4) While guiding the plastic clips into the areas behind the platen and to both sides of the printer top cover, lower the platen so that its grooved collars rest on the platen latches.
- (5) Position each of the plastic clips against the stud mounted to the printer side frame. Push the clip until it snaps into place around the stud, as shown in Figure 2-15.
- (6) Press the platen latches and push the pin-feed platen down into the locked position.
- (7) Rotate the platen in both directions to make sure it is held firmly by the platen latches.
- (8) Close or replace the printer access cover and platen skirts.

2.4.4 Forms Tractor

Removal:

- (1) Remove any paper from the forms tractor.

- (2) Press the two clamp buttons (Figure 2-16) in as far as possible and lift the assembly straight up.

Reinstallation:

- (1) Pull the paper release lever and paper bail lever forward toward the front of the HyTerm.
- (2) Carefully lower the forms tractor down over the platen until its clamps (Figure 2-16) are resting on the platen shaft.
- (3) Position the fork on the inside left end of the forms tractor around the platen adjust lever, as shown in Figure 2-17.
- (4) Guide the large fork inside the right end of the forms tractor around the paper release lever, as shown in Figure 2-18.
- (5) Press the two clamp buttons in and lower the forms tractor down on the platen shaft. Release the clamp buttons to clamp the assembly to the platen.
- (6) Tilt the outfeed paper support forward and verify that the paper release lever snaps to its rearward position (Figure 2-19), to apply pressure to the paper and platen. Swing the outfeed paper support back to its normal position and verify that the paper release lever is pulled forward, as shown in Figure 2-18. This is the normal operating position with paper tension released.
- (7) Verify that operating the forms tractor platen adjust lever (Figure 2-20) moves the printer platen adjust lever (Figure 2-17).
- (8) Adjust the two belt drives to the appropriate form width by loosening the thumbwheel clamps and sliding the drive sideways until the desired position is reached (Figure 2-20).

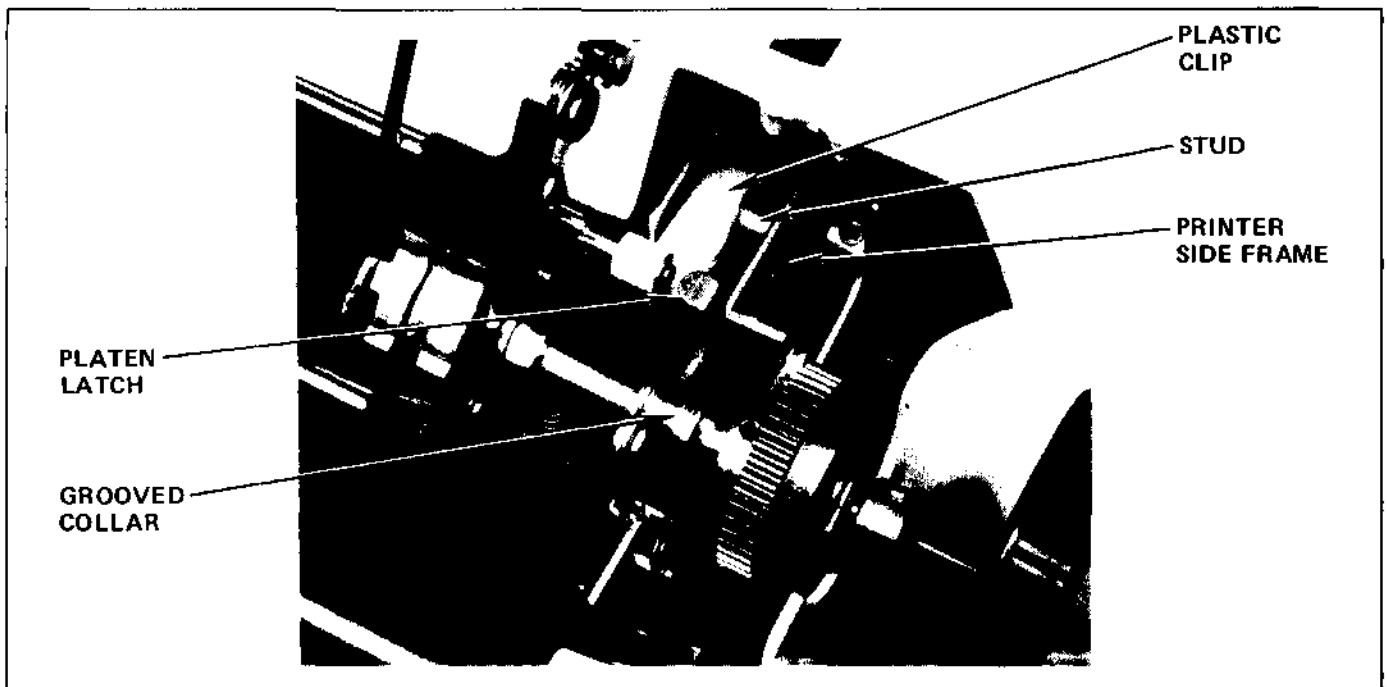

Figure 2-15. Plastic Clip and Stud

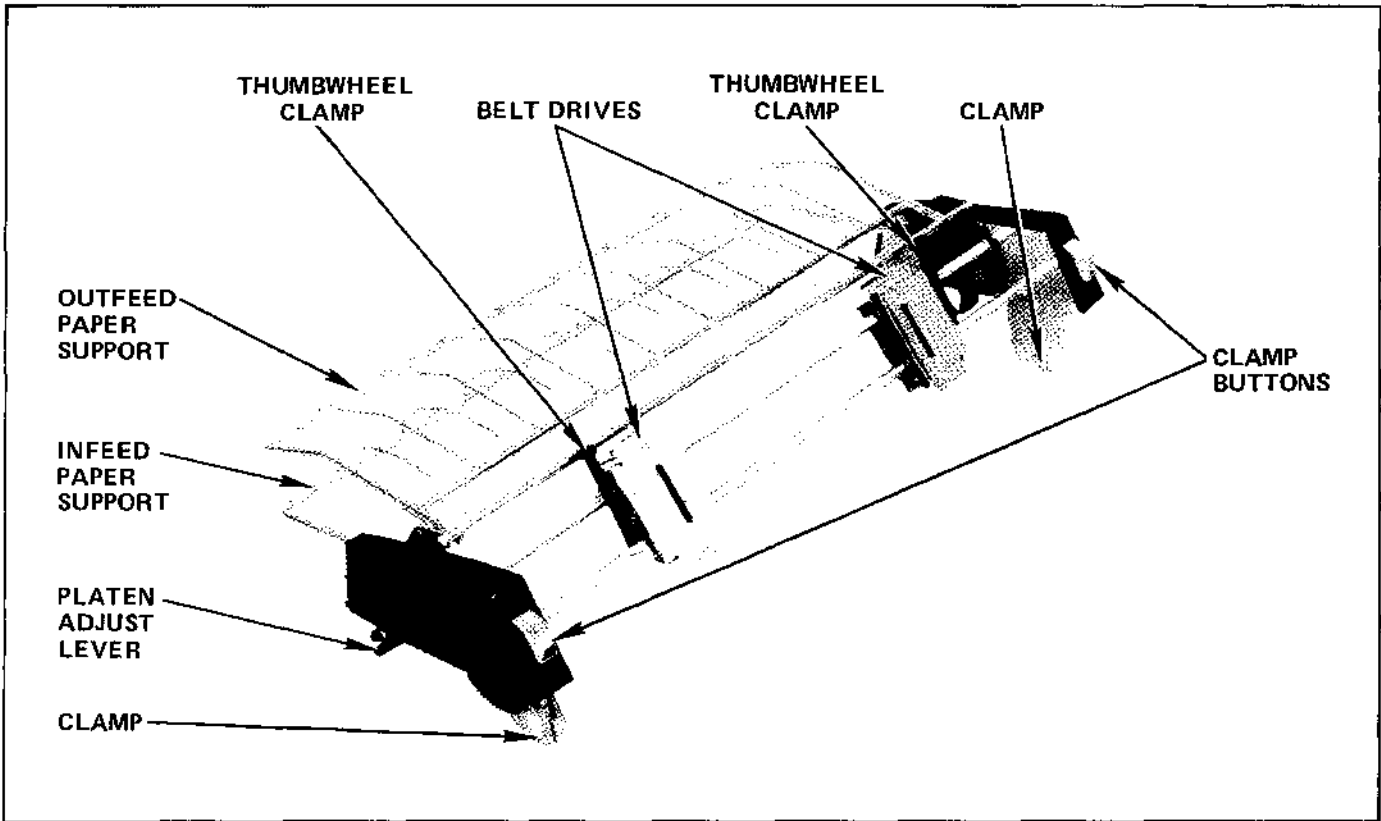

Figure 2-16. Forms Tractor

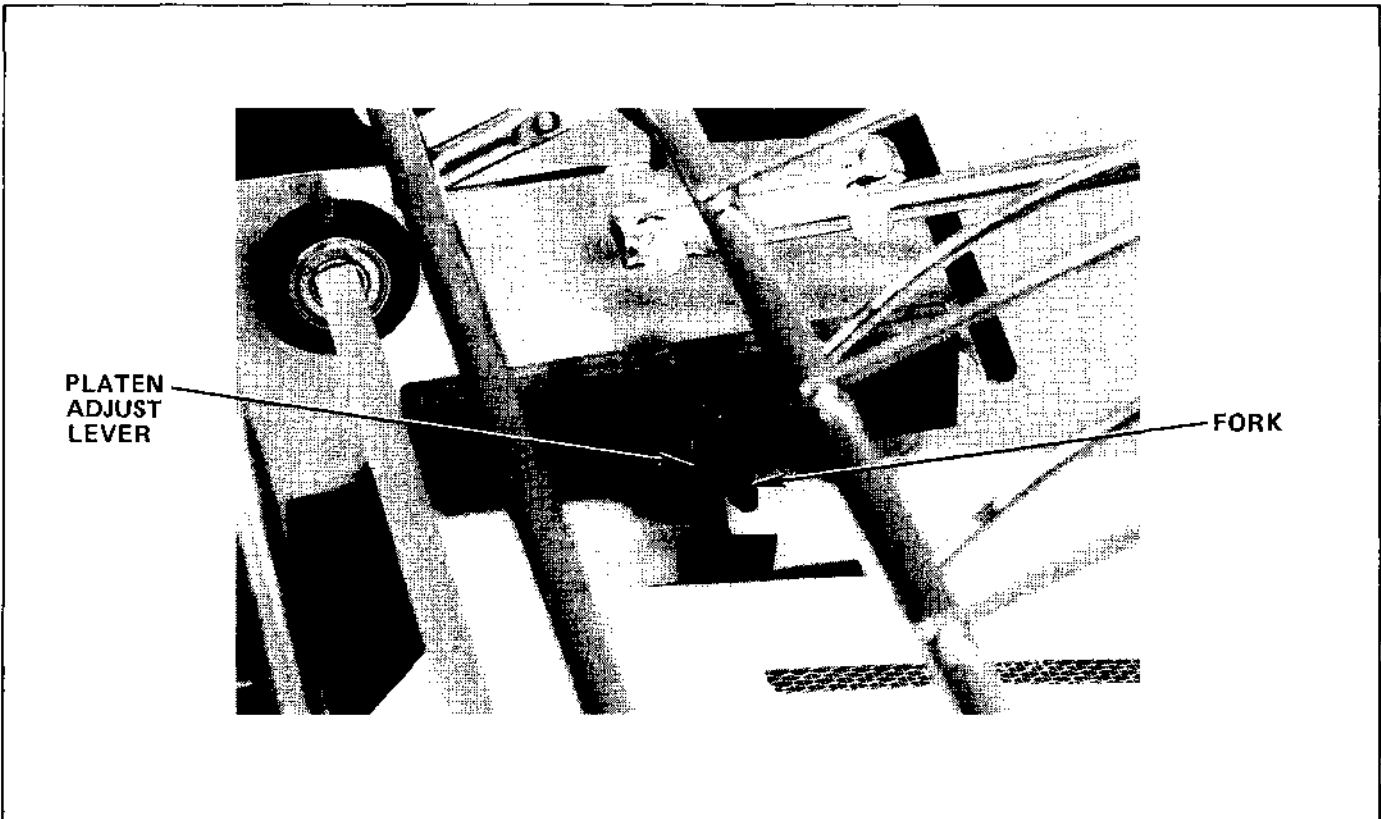

Figure 2-17. Forms Tractor and Platen Adjust Lever

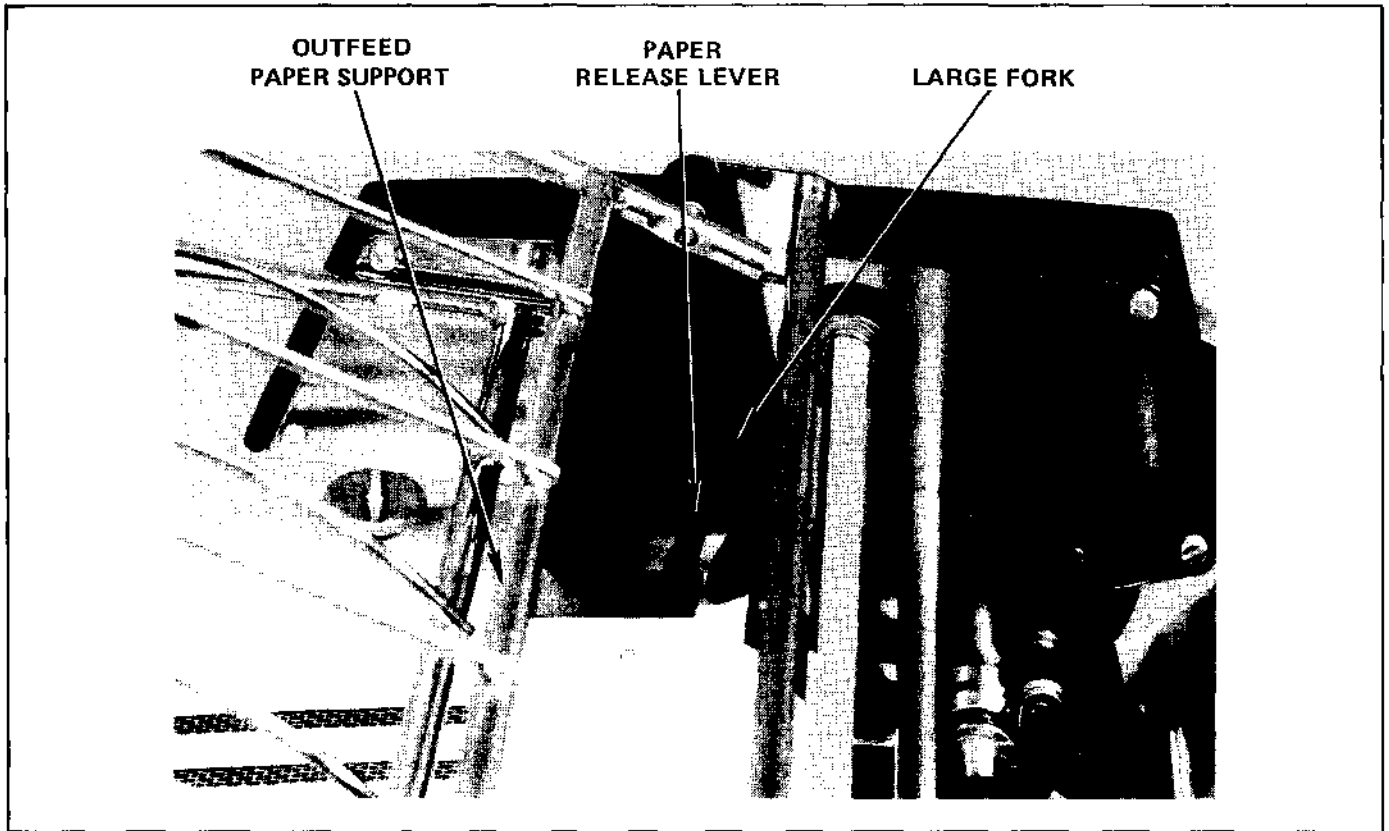

Figure 2-18. Forms Tractor and Paper Release Lever (Tension Removed)

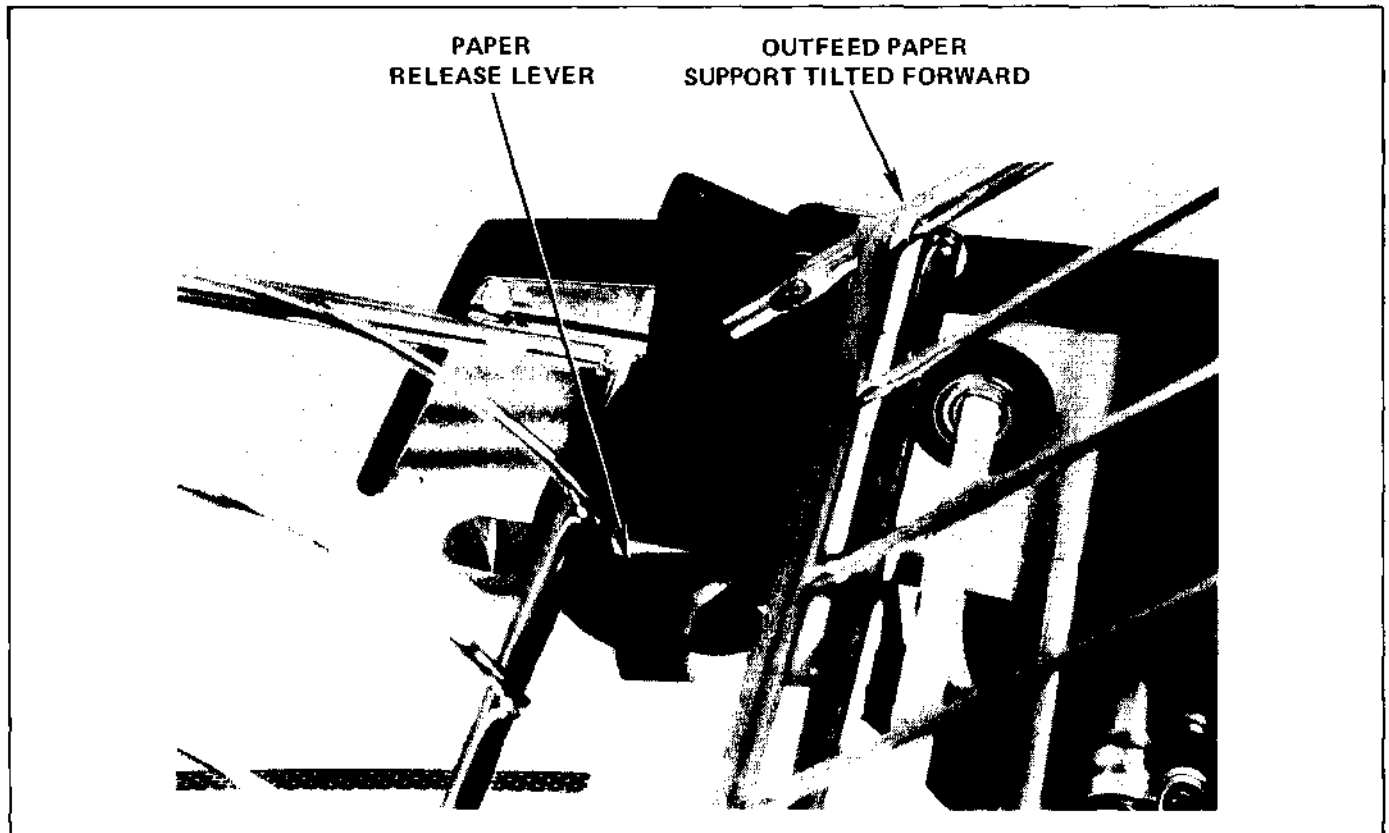

Figure 2-19. Forms Tractor and Paper Release Lever (Tension Applied)

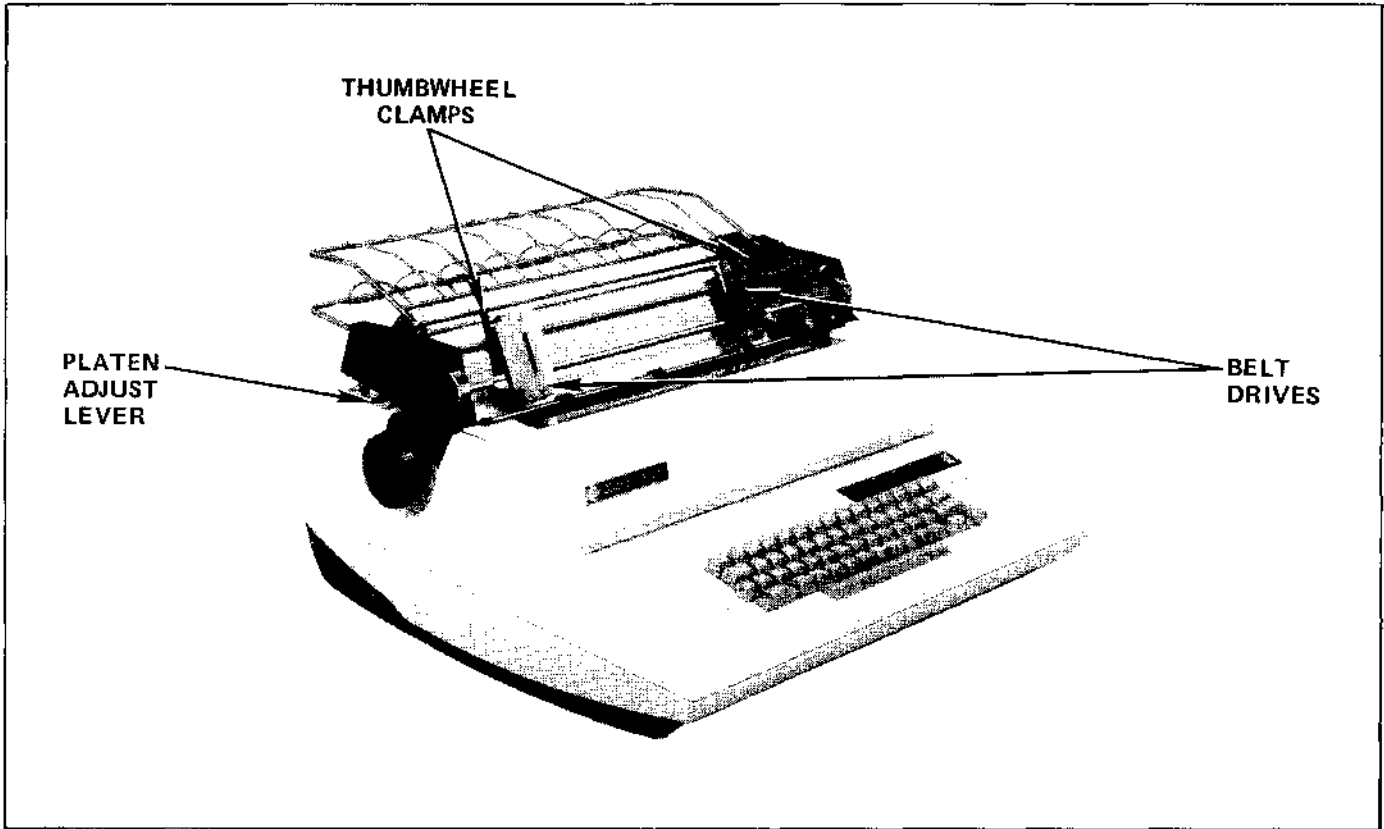

Figure 2-20 Forms Tractor Installed

SECTION 3 FUNCTIONAL DESCRIPTION

3.1 INTRODUCTION

This section describes HyTerm operation from an outside-looking-in point of view. It is intended primarily for the programmer or systems analyst/planner, although some of the information contained here may be helpful to the HyTerm operator and others.

This section does not contain information on theory of operation, which may be found in Section 2 of the Maintenance Manual. Information concerning error indications and control, and the use of keyboard and control switches is contained in Section 2, Operating Instructions.

3.1.1 Local/Remote

Most HyTerm functions are identical in both Local and Remote modes. The major difference is that in Remote mode, data is transmitted and received over the communications link. In Local mode all data transfer is inhibited. In Local mode the HyTerm is controlled completely by the operator, and information pertaining to this is contained in Section 2, Operating Instructions. In Remote mode the HyTerm can be controlled largely by the host computer, and it is this control that is covered in this section.

While in Local mode, the LOCAL key on the keyboard is latched down. In Remote mode the key is "up." Pressing the LOCAL key alternately switches the HyTerm between Local and Remote modes.

3.2 COMMUNICATIONS PRINCIPLES

In Remote mode, the HyTerm transmits and receives ASCII-coded data over its EIA RS-232-C compatible interface at rates of 10, 15, 30, or 120 characters per second (cps). Any of the 128 ASCII characters can be transmitted or received, but NUL (all zero-bits) and DEL (all one-bits) are discarded upon reception. The American National Standards Institute (ANSI) convention for asynchronous data transmission is observed, in which each character code consists of a start bit, seven data bits, a parity bit, and one or two stop bits. Character parity is selectable (EVEN/ODD/MARK). With MARK parity selected, incoming data is not checked for parity, and the transmitted parity bit is always a mark (logic 1). Further information on the data format can be found in Section 4, Interface.

Half- or full-duplex operation is selectable. During half-duplex, all keyboard data is both printed and transmitted. During full-duplex, keyboard data is transmitted without being printed – the only data printed is that received over the data link.

3.3 RESET/INITIALIZATION

The HyTerm is automatically initialized at power on. During operation, it can be re-initialized locally by depressing the CLEAR pushbutton on the control panel. After a Clear, the following conditions are in effect:

- (1) Normal print mode (not Graphics)
- (2) Forward printing
- (3) Print in black
- (4) Horizontal spacing is controlled by the setting of the SPACING switch
- (5) Vertical spacing set to 6 lines per inch
- (6) All horizontal tab stops are cleared
- (7) Left and right margins are cleared to their extreme outward positions
- (8) Terminal print buffer is cleared
- (9) The carriage moves the printhead to the leftmost print position (horizontal position 0)
- (10) Vertical position is cleared to zero (paper does not move)
- (11) Form length set

3.4 CHARACTER GENERATION

With one minor exception, the HyTerm logic recognizes and handles all characters the same regardless of their originating point. (The exception is the DEL code: this will be covered shortly.) In Remote mode, characters are received over the data link or from the keyboard: in Local mode, they are received from the keyboard only. In the remainder of this section, when the source of a character is not specifically noted, it is understood that the character may have originated at either the keyboard or the data link.

3.4.1 Two- and Three-Character Sequences

Two- and three-character sequences are used to alter normal printing, carriage movement, or paper movement. The first character of a two- or three-character sequence is always the ESC character. Reception of this character always means that the following one or two characters have a different meaning than they normally do.

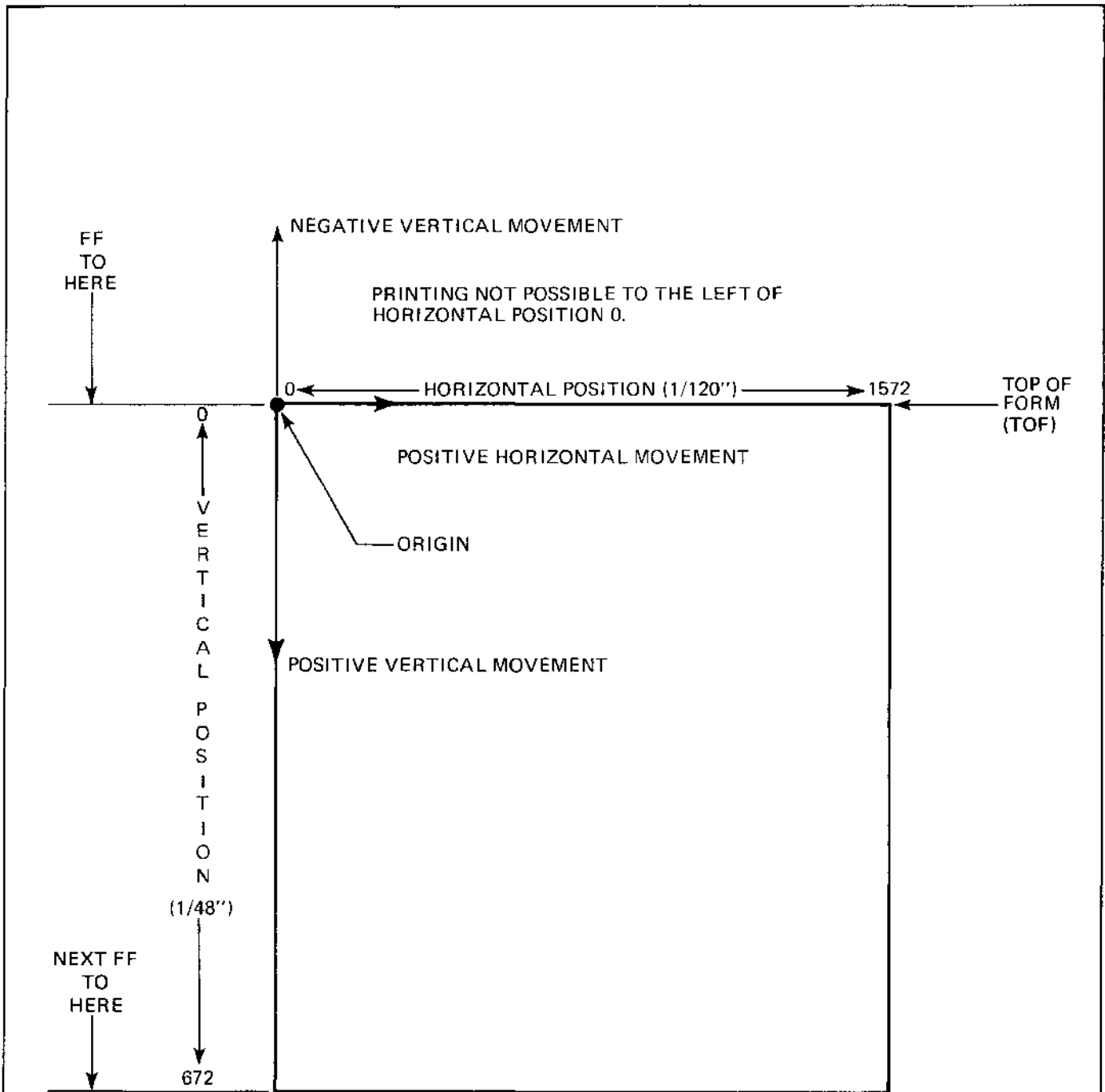

NOTE : "MOVEMENT" ARROWS DEPICT CARRIAGE MOVEMENT RELATIVE TO PAPER, AND NOT ACTUAL PAPER MOVEMENT DIRECTION.

Figure 3-1. Printing Format Factors

3.5 PRINTING FORMAT

Any of the 94 graphic characters in the ASCII code set can be printed. Printing format is dependent upon horizontal character spacing and vertical line spacing. Either of these factors can be independently controlled; an "index" is used to define the specific motion desired. Any point on a page can be defined in terms of a "horizontal position" and "vertical position".

Either of two "standard" formats can be selected via the SPACING switch on the control panel. Additional formats can be obtained by changing the Horizontal Motion Index or the Vertical Motion Index, using three-character sequences.

3.5.1 Definition of Terms (See Figure 3-1)

- (1) Origin: the position of the print head after a Form Feed and an Absolute Tab to position 0 (or after a Clear). The first print position on the first line of a page.
- (2) Horizontal Motion Index (HMI): the number of 1/120-inch increments that the carriage moves after printing a character (or when spacing). Minimum HMI is 0 (no spacing), maximum is 125 (125/120 = 1.04 inches).
- (3) Vertical Motion Index (VMI): the number of 1/48-inch increments moved by the paper (platen) for each line feed or negative line feed. Minimum VMI is 0, maximum is 125.
- (4) Horizontal Position: the horizontal distance (in 1/120-inch increments) between the print head and the origin. Minimum horizontal position = 0, maximum = 1572.
- (5) Vertical Position: the vertical distance (in 1/48 inch increments) between the current print line and the first line on the page (the origin). Minimum vertical position = 0, maximum = 672 (for 14-inch page).
- (6) Print Position: the horizontal area capable of being occupied by a single print character. This can be likened to a print "column" on a line printer, except that it is variable: the number of print positions per line is dependent upon the HMI. The minimum number of print positions per line is 13 (when HMI = 125); the maximum number is 1573 (when HMI = 1). The leftmost print position is position 1.

$$\text{print position no.} = \left(\frac{\text{horizontal position}}{\text{HMI}} \right) + 1$$

Note that the combination scale on the printer access cover (see Figure 2-4) has markings beginning at 0 rather than 1: when 10 or 12 characters-per-inch spacing is being used, the value pointed out on this scale is actually one less than the current print position.

- (7) Line: the vertical distance capable of being occupied by a row of printed characters. The height of the line is equal to the VMI x 1/48 inch.

$$\text{line no.} = \left(\frac{\text{vertical position}}{\text{VMI}} \right) + 1$$

3.5.2 Standard Formats

Standard vertical spacing is 6 lines per inch. Standard horizontal spacing can be either 10 or 12 characters per inch, depending upon the setting of the SPACING switch.

Table 3-1 summarizes the horizontal spacing available through the SPACING switch.

Table 3-1. SPACING Switch

| SPACING Switch | Horizontal Spacing | | |
|----------------|--------------------|-------------------|-----|
| | Chars/in | Chars/line (max.) | HMI |
| 10 | 10 | 132 | 12 |
| 12 | 12 | 158 | 10 |

Whenever the SPACING switch is repositioned and an optional horizontal format has not been selected, the values listed in Table 3-1 for the new position are used for horizontal spacing.

Additional formats can be obtained by utilizing variable indexing, which can override the standard formats.

3.5.3 Optional Formats (Variable Indexing)

Either of the format factors can be altered by utilizing special escape sequences. However, execution of any of these sequences does not immediately alter horizontal or vertical position: it does, however, change subsequent operations by redefining the variable format factors. It is recommended that a Form Feed and an Absolute Tab to location 0 be performed prior to changing any format factors.

Changing the VMI leaves the HMI still under the control of the SPACING switch. A Clear operation cancels the optional format factors, and returns format control to the SPACING switch.

3.5.3.1 VARIABLE HMI

The standard HMI can be altered by executing the 3-character sequence ESC US (n), where the (n) represents an ASCII character whose decimal value is one greater than the number of increments (1/120 inch) the carriage will move after printing a character or when spacing.

$$\text{HMI} = (\text{ASCII character} - 1) \times 1/120 \text{ inch}$$

The ASCII code chart is reorganized into decimal value sequence for convenience in Table 3-2. For example, to set the HMI at 10, the three-character sequence ESC US VT must be executed, since the VT code has a decimal value of 11.

NUL and DEL cannot be used, so minimum HMI is 0 increments, and maximum is 125 increments. Maximum horizontal position is set at 1572; any attempt to move the carriage beyond this position will result in the carriage's stopping at the last print position prior to horizontal position 1573. (Example: with HMI set at 20, carriage cannot move beyond position 1560; with HMI set at 10, carriage cannot move beyond position 1570.)

3.5.3.2 VARIABLE VMI

The standard VMI can be altered by executing the 3-character sequence ESC RS (n) where the (n) represents an ASCII character whose decimal value is one greater than the number of increments (1/48 inch) the paper will move for each line feed or negative line feed. Minimum VMI is 0, maximum is 125. Refer to Table 3-2.

$$\text{VMI} = (\text{ASCII character} - 1) \times 1/48 \text{ inch}$$

3.6 CONTROL FUNCTIONS

All codes and sequences that cause functions to be performed are summarized in Table 3-3. Details are presented in the following paragraphs.

3.6.1 Control of Printing

Any of the 94 printing ASCII characters, when received, normally prints and then causes the carriage to move one print position to the right. This printing action can be affected by reception of ESC A or ESC B, or by operation of the UC ONLY key on the keyboard.

3.6.1.1 RED/BLACK PRINTING (ESC A/ESC B)

The HyTerm is initialized printing in black. To print in red, an ESC A sequence is issued. To return to black, an ESC B is issued. If red is selected with a single-color ribbon installed, all printing operations other than ribbon lift occur. Printing may or may not occur, depending upon the amount of ink remaining on the type face. Note that the upper case A and B must be used. The lower case "a" and "b" codes will have no effect.

3.6.1.2 UPPER CASE ONLY

When the UPPER CASE ONLY switch is on, all lower case alphabetic characters from the keyboard are converted to their upper case equivalents before being printed or transmitted. Non-alphabetic characters are unaffected, as are all characters received over the data link.

Table 3-2. Decimal Values for ASCII Character

| | | Units | | | | | | | | | |
|---|-----|-------|-----|-----|-----|-----|-----|-----|-----|-----|-----|
| | | 0 | 1 | 2 | 3 | 4 | 5 | 6 | 7 | 8 | 9 |
| | 0 | | SOH | STX | ETX | EOT | ENQ | ACK | BEL | BS | HT |
| | 10 | LF | VT | FF | CR | SO | SI | DLE | DC1 | DC2 | DC3 |
| | 20 | DC4 | NAK | SYN | ETB | CAN | EM | SUB | ESC | FS | GS |
| T | 30 | RS | US | SP | ! | " | # | \$ | % | & | ' |
| | 40 | (|) | * | + | , | - | . | / | 0 | 1 |
| e | 50 | 2 | 3 | 4 | 5 | 6 | 7 | 8 | 9 | : | ; |
| | 60 | < | = | > | ? | @ | A | B | C | D | E |
| n | 70 | F | G | H | I | J | K | L | M | N | O |
| | 80 | P | Q | R | S | T | U | V | W | X | Y |
| s | 90 | Z | [| \ |] | ^ | _ | ' | a | b | c |
| | 100 | d | e | f | g | h | i | j | k | l | m |
| | 110 | n | o | p | q | r | s | t | u | v | w |
| | 120 | x | y | z | { | | } | ~ | | | |

Table 3-3. Control Functions

| Code(s) | Function | Action | | | |
|------------|--------------------------------------|--------|----------|--------|-------|
| | | Print | Carriage | Platen | Other |
| ACK | Sent to Acknowledge Receipt of ETX | | | | X |
| BEL | Sound Audible Alarm | | | | X |
| BS | Backspace | | X | | |
| CR | Carriage Return | | X | | |
| DEL | Ignored | | | | |
| ETX | Synchronizes Terminal with Host | | | | X |
| ESC 1 | Set Horizontal Tab Stop | | X | | |
| ESC 2 | Clear All Tab Stops | | X | | |
| ESC 3 | Graphics On | | X | X | |
| ESC 4 | Graphics Off | | X | X | |
| ESC 5 | Forward Print On | | X | | |
| ESC 6 | Backward Print On | | X | | |
| ESC 8 | Clear Individual Tab Stop | | X | | |
| ESC 9 | Set Left Margin | | X | | |
| ESC 0 | Set Right Margin | | X | | |
| ESC A | Print in Red | X | | | |
| ESC B | Print in Black | X | | | |
| ESC D | Negative Half-Line Feed | | | X | |
| ESC U | Half-Line Feed | | | X | |
| ESC LF | Negative Line Feed | | | X | |
| ESC HT (n) | Absolute Horizontal Tab | | X | | |
| ESC VT (n) | Absolute Vertical Tab | | | X | |
| ESC RS (n) | Define Vertical Motion Index (VMI) | | | X | |
| ESC US (n) | Define Horizontal Motion Index (HMI) | | X | | |
| FF | Form Feed | | | X | |
| HT | Horizontal Tab (normal) | | X | | |
| LF | Line Feed | | | X | |
| NUL | Ignored | | | | |
| SP | Space | | X | | |

3.6.2 Control of Carriage Movement

There are several different codes and sequences that affect carriage movement, in addition to the normal movement following printing. In addition, some of these functions (related to tabbing) can also be accomplished with the keyboard function keys. See Section 2.

Defining the Horizontal Motion Index (HMI) has been covered previously in Section 3.5.3.1.

3.6.2.1 SPACE (SP)

Moves carriage one print position to right. In backward print mode, moves carriage one print position to left. In Graphics, moves carriage 1/60 inch.

3.6.2.2 BACKSPACE (BS)

Moves carriage one print position to left. In Backward

Print mode, moves carriage one print position to right. In Graphics, moves carriage 1/60 inch.

3.6.2.3 CARRIAGE RETURN (CR)

Moves carriage to left margin. Also causes line feed if AUTO LF switch is on. Cancels Graphics and Backward Print mode.

3.6.2.4 HORIZONTAL TABBING (HT, ESC 1, ESC 2, ESC HT)

Two methods of tabbing are possible. One method, called "Normal Tab", is similar to the traditional system used on typewriters in that "tab stops" are set at predetermined print positions, and when the tab command is executed, the carriage moves to the next sequential tab stop. The other method, termed "Absolute Tab", is unique in that it does not require prior setting of tab stops, and allows automatic positioning of the carriage to any of the first 126 print positions, from any other print position.

The method of tabbing to be used is specified by the character sequence employed. The Horizontal Tab (HT) character alone executes a Normal Tab operation: an ESC HT initiates an Absolute Tab.

Since tabbing provides positioning only to normal print positions, finer positioning requires the use of spacing in Graphics mode.

3.6.2.4.1 Normal Horizontal Tab. Tab stops can be set or cleared, and tab commands executed, either locally or remotely. Tab stops can be set at any print position up to position 160. Once tab stops are set, execution of a Horizontal Tab (HT) can be initiated from either the keyboard or the communications link, and causes the carriage to seek the next tab stop set to its right. Should an HT be executed with no tab stop having been set to the right of the present horizontal position, the carriage will move to the rightmost print position.

Tab stops can be set by first positioning the carriage to the desired print position and then executing an ESC 1 sequence. Keeping in mind that the tab stops can be set at only the first 160 print positions, the formula for determining a tab position is as follows:

$$\text{horizontal tab position (1-160)} = \left(\frac{\text{horizontal position}}{\text{HMI}} \right) + 1$$

Subsequent TAB operations automatically move the carriage to the next sequential tab stop to the right. Individual tab stops are cleared by first tabbing to the stop to be cleared and then executing an ESC 8 sequence; all tab stops are cleared at one time by execution of an ESC 2 sequence. If Graphics mode is used, operation can be slightly different. See 3.6.2.5.

3.6.2.4.2 Absolute Horizontal Tab. Using Absolute Tab, the carriage can be positioned directly to any of the first 126 print positions without the need for prior setting of tab stops. This is accomplished by preceding the Horizontal Tab command (HT) with an ESC character, and following it with the ASCII character whose decimal value indicates the print position desired (see Table 3-2).

Note that this method of tabbing also makes possible tabbing to the left. For example, with the carriage positioned at print position 100, an ESC HT 1 sequence will move the carriage directly to print position 49, the decimal value of the ASCII code for digit 1. The leftmost print position is considered location 1. Any ASCII character other than NUL and DEL can be used, making possible direct tabbing to any of the first 126 print positions. The horizontal position at the completion of an Absolute Tab operation is computed as follows:

$$\text{horizontal position} = (\text{ASCII character} - 1) \times \text{HMI}$$

The 3-character tab sequence can be issued from the keyboard or from the communications link. Note that in 10 or 12 characters-per-inch, the final position indicated on the combination scale will be one less than the actual print position, since the scale numbering starts at 0 instead of 1. Absolute Tab is unchanged in Graphics mode.

3.6.2.5 GRAPHICS (ESC 3, ESC 4)

To take advantage of the HyType's graphics capability, the HyTerm can be placed into Graphics mode by reception of an ESC 3 sequence. The HyTerm remains in Graphics until a Carriage Return or an ESC 4 sequence is executed.

While in Graphics, carriage movement is completely divorced from printing: i.e., printing a character does not automatically move the carriage. The carriage can be moved only by executing a tab, space, carriage return, or backspace operation.

In Graphics mode, the space and backspace commands move the carriage only 1/60 inch instead of the selected horizontal index amount. Absolute Horizontal Tabs operate the same in Graphics as in Normal mode. However, Normal Horizontal Tabs always move the carriage some multiple of the HMI, so if the carriage is not resting precisely on a normal print position when the tab is executed, it will also be off at the completion of the tab. The same is true of tabs performed after leaving Graphics via the ESC 4 sequence. To insure proper tab operation in Graphics and after leaving Graphics, make sure the carriage is positioned at a normal print position before the tab is executed or before the ESC 4 is performed. In all cases, a subsequent carriage return will resynchronize tab stops with print position.

The tab commands operate the same as they do in Normal mode. In Graphics mode, however, the space and backspace commands move the carriage only 1/60 inch instead of the selected horizontal index amount.

Paper movement commands can be heavily utilized in Graphics. Vertical Tab (VT) and Form Feed (FF) operations are unchanged in Graphics, but Line Feed (LF) and Negative Line Feed (ESC LF) cause only 1/48 inch of paper movement, instead of the full line (VMI) movement they effect in Normal mode.

3.6.2.6 FORWARD/BACKWARD PRINT (ESC 5/ESC 6)

To enter Backward Print mode an ESC 6 sequence is used. An ESC 5 sequence or a carriage return will reestablish Forward Print mode.

During Forward Print each character printed also causes incremental carriage movement to the right (except during Graphics). During Backward Print this motion is reversed,

moving the carriage to the left. The action of the Space and Backspace keys and codes is also reversed in Backward Print. Note, however, that tabbing operations, carriage return, and all paper movement functions are not affected by being in the Backward Print mode. If Backward Print and Graphics are both used at the same time, Graphics eliminates carriage movement following printing, so only the Space and Backspace operations are affected.

Note that the direction of carriage movement is the only change made by the HyTerm in Backward Print mode: the HyTerm continues to print characters in the same sequence received. It is the responsibility of the host computer to transmit the data "from right to left" if backward printing is used.

3.6.2.7 MARGINS (ESC 9, ESC 0)

ESC 9 sets the left margin at the current carriage position. ESC 0 sets the right margin.

The new left margin affects only carriage returns. Once the left margin has been altered, CR codes cause the carriage to return only as far as the new margin position. The carriage can be moved past the margin by backspacing, but only as far as the "extreme" left margin position (horizontal position 0).

Changing the right margin causes the audible alarm to sound as the carriage passes the new setting. It does not disable the keyboard or prevent further printing. Printing can continue past the right margin all the way to the "extreme" right margin position (same position as right margin after CLEAR operation), at which point any further characters will be overprinted on the characters previously printed there.

3.6.3 Control of Platen (Paper) Movement

There are 9 codes and sequences that affect paper movement. Only one of these, Form Feed, can be accomplished from the front panel switches. (Setting top-of-form is also done through these switches, but this can only be accomplished locally. See Section 2.)

Defining the Vertical Motion Index (VMI) has been covered previously in Section 3.5.3.2.

3.6.3.1 LINE FEEDS (LF, ESC LF, USC U, ESC D)

A Line Feed (LF) code will cause the form to move up one line (one VMI). An ESC LF sequence acts as a negative line feed, causing the form to move down one line. See Graphics, Section 3.6.2.5. A line feed is also accomplished automatically as a result of a Carriage Return operation when the AUTO LF switch is on.

A Half-Line Feed (ESC U) causes the form to move up 1/2 line. A negative Half-Line Feed (ESC D) moves the form down 1/2 line. These two commands are unchanged in Graphics. If the VMI is set to some odd number, the total paper movement will be one increment (1/48 inch) less than 1/2 line.

3.6.3.2 FORM FEED (FF)

Execution of a Form Feed (FF) moves the paper upward so that the print head is positioned at the first line of the next page. Initial form registration is accomplished by manually turning the platen so that the print head is at the first line of the form and then depressing the SET TOF key on the keyboard. All subsequent platen control is monitored by the HyTerm so that any subsequent Form Feed will move the paper exactly the right distance to allow printing on the first line of the next page. Factors affecting the amount of movement in this case are (1) vertical position before the FF, (2) VMI, and (3) form size (set by control panel switch). Note that if the platen is turned by hand, or if the form size switch setting is changed and SET TOF operated, subsequent Form Feeds will not move the paper to the expected position.

The Form Feed function can be executed locally by depressing the FORM FEED switch or by producing the FF code on the alphanumeric section of the keyboard. The FF code is transmitted in the latter case, but not in the former.

3.6.3.3 GRAPHICS (ESC 3, ESC 4)

The impact of Graphics mode on platen movement has been covered in Section 3.6.2.5. Briefly, line feeds and negative line feeds move the platen 1/48 inch instead of one VMI. Vertical tabs are unaffected.

3.6.3.4 VERTICAL TABBING (ESC VT)

Unlike horizontal tab, there is only one method of tabbing, Absolute Vertical Tab. It is analogous to Absolute Horizontal Tab.

Using Absolute Vertical Tab, the form can be moved directly to any of the first 126 lines on the page from any other line on the page. Absolute Vertical Tab is initiated by a 3-character sequence ESC VT (n) where the (n) represents an ASCII character whose decimal value is equal to the number of the line on the form to be reached. NUL and DEL cannot be used. The top line of the form is line number 1, the second is line number 2, etc. The actual amount of paper (platen) movement is determined by (a) vertical position before VT execution, (b) the ASCII character used, and (c) the Vertical Motion Index (VMI). Ultimate position is determined by the following formula:

$$\text{vertical position} = (\text{ASCII character} - 1) \times \text{VMI}$$

Since page size is defined in inches, and not in lines, it is possible to have more or less than 126 lines per page. If there are more than 126 lines per page, it is possible to tab to only the first 126 lines; if there are less than 126 lines per page, it is possible to tab beyond the end of the page. For example, if there are 66 lines per page and a tab to line 76 is executed, the paper will be positioned to line 10 of the next page. Once a page boundary is crossed, all subsequent paper movement is in relation to line 1 of the new page.

When a forms tractor or bottom-feed printer is used, absolute vertical tabs of more than two or three lines in the negative direction should not be attempted, because the forms tractor cannot push the paper back down. Uneven print lines or paper jams will result.

3.6.4 Other Control Functions

The remaining control functions have to do with sounding the audible alarm and preventing print buffer overrun.

3.6.4.1 SOUND AUDIBLE ALARM (BEL)

Each time the BEL character is received it sounds the audible alarm for 1/4 second. This is normally used by the host computer to get the operator's attention for some reason or other. This alarm indication is the same as that given for error conditions (see 2.3.4), except that the ERROR lamp is not illuminated.

3.6.4.2 PREVENTING BUFFER OVERRUN (ACK, ETX, NUL, DEL)

All data to be printed, whether from the keyboard or the data link, is stored in a print buffer (memory) until the printer is able to accept it. This buffer can store up to 158 characters, but if data is received faster than it can be printed, a buffer "OVERRUN" can still occur. This normally does not occur at 10 or 15 characters per second, but it can occur at 30 or 120 cps if suitable precautions are not observed. These precautions traditionally include NUL or DEL codes transmitted as "pad" or timefill characters after carriage returns, vertical tabs, form feeds, etc. (NUL and DEL are always discarded when received over the data link: they are not loaded into the print buffer.) Backward Printing can also be utilized to eliminate carriage returns. However, when timefill characters are used, a sufficient number of them must always be used in order to fully insure correct operation in worst case situations, and this results in lower overall throughput.

In order to speed up throughput and still guarantee against buffer overrun, the ETX/ACK sequence can be used in a variety of different configurations. The HyTerm transmits an ACK character each time an ETX is removed from the print buffer. A typical example is as follows:

- (1) Host computer transmits fixed-length, 79-character messages. Each message is ended with an ETX.
- (2) As the HyTerm is printing out the first message, it may already be receiving the second. As it withdraws the ETX (end of the first message) from its print buffer, it transmits an ACK to the host computer, which interprets this as a signal to begin sending the third message.
- (3) So long as no more than two messages (158 characters, enough to fill the print buffer) are outstanding at any one time, data transfer can continue uninterrupted, resulting in highly efficient use of the data link.
- (4) If two messages are outstanding, the host computer must delay transmission of the next message until an ACK is received from the HyTerm.

3.7 MOTION MINIMIZATION

The motion minimization feature resolves a sequence of carriage- and paper-movement commands to one single operation which moves the print head and paper via the shortest path to the position which would result from performing each individual operation. The purpose of this feature is to reduce the time taken by the printer in executing these commands. Therefore, any motion command received while the print buffer is empty will be executed immediately, and will not be accumulated; motion is accumulated only while the printer is busy performing other functions. Likewise, if motion has been accumulated and no data has arrived for a period of time, allowing the print buffer to become empty, the accumulation process will terminate and all motion accumulated to that point will be executed. The net result is faster throughput.

Reception of any printing character terminates the motion accumulation and causes all motion accumulated to be executed before the character is printed. Reception of any command that would cause paper movement across a page boundary terminates vertical accumulation and causes any vertical motion accumulated to be executed; it does not affect horizontal motion accumulation.

SECTION 4 INTERFACE

4.1 INTRODUCTION

The dotted box in Figure 4-1 illustrates the area of the HyTerm covered in this section. Included is information on the connecting cable and plugs, signal names and functions, input and output level-converter integrated circuits, voltages, timing, and data coding and format. Information on the modem must be obtained from the modem manufacturer. Information concerning the USART (Universal Synchronous/Asynchronous Receiver/Transmitter) and the terminal logic will be found in Sections 2 and 4 of the Maintenance Manual. The optional current-loop interface is covered separately at the end of this section (see 4.10).

The standard interface between the HyTerm and the modem is electrically compatible with the Electronic Industries Association (EIA) Standard RS-232-C and the International Telegraph and Telephone Consultative Committee (C.C.I.T.T.) Recommendation V.24. Those portions of the standard/recommendation utilized by the HyTerm are noted in this section: if further information is required, refer to the related documents listed in Section 1.

4.2 MODEM COMPATIBILITY

The HyTerm can be connected to any Bell type 103A or

113A modem, or an equivalent modem from another manufacturer. Time Division Multiplexed (TDM) or Frequency Division Multiplexed (FDM) equipment may be used in place of a modem, providing the equipment "looks like" one of the above modems to the HyTerm.

4.3 FUNCTIONAL DESCRIPTION

The main purpose of the interface is to adapt the TTL logic levels used inside the HyTerm to the 12-volt (nominal) signals used by the modem so that data can be transferred between the two. Since the EIA standard allows voltage swings as far as $\pm 25V$, the HyTerm receiver circuits must be capable of handling these levels. The HyTerm provides signals in the range of 7 to 12 volts to the modem.

In addition to the data signals that are transferred between the HyTerm and the modem, certain control signals are required to notify each device that the other is ready, so there will be no data loss. The input control signals to the HyTerm are connected in a "fail safe" mode, so that an "off" or "inactive" indication will result if the modem is powered down or if the connecting cable is unplugged.

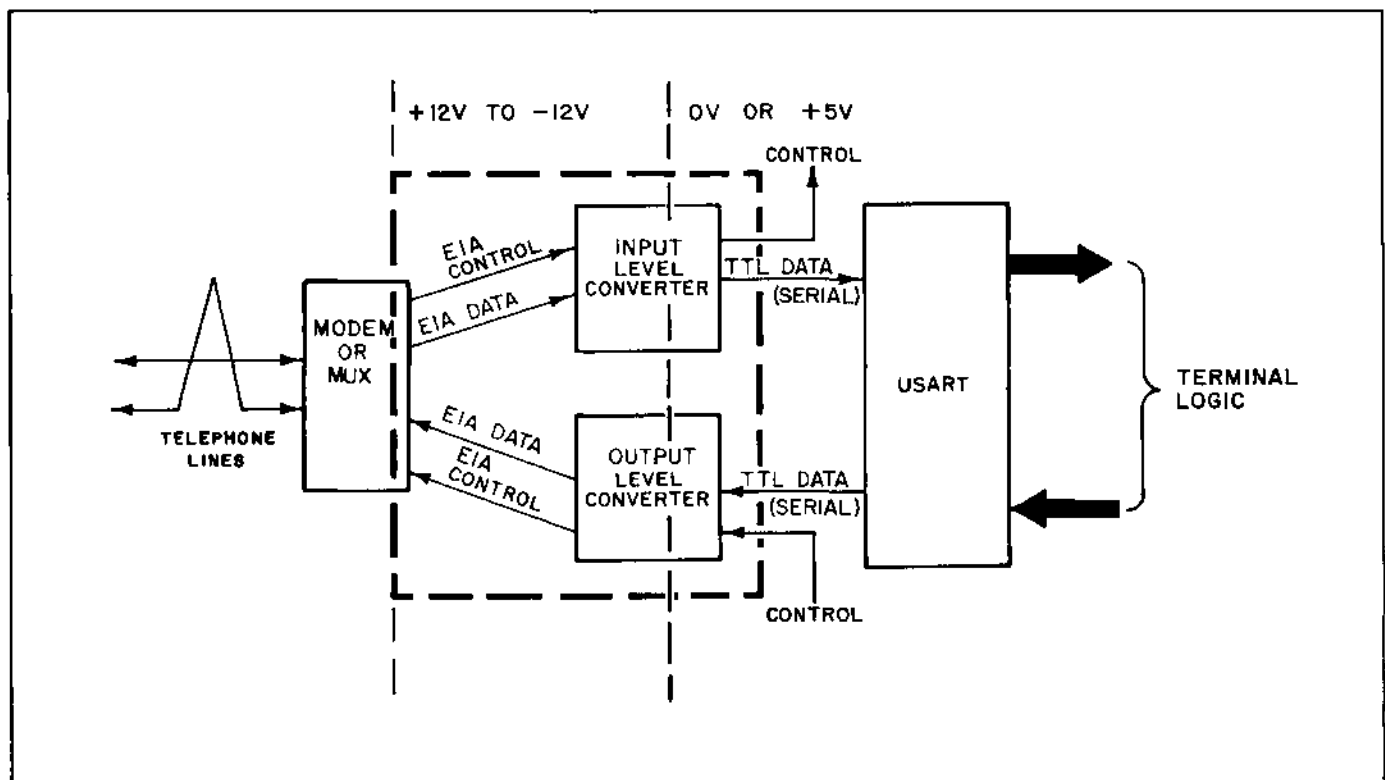

Figure 4-1. Interface Functional Block Diagram

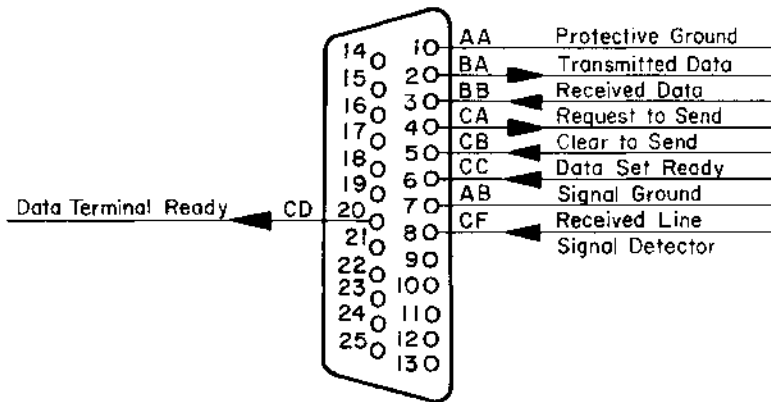

Figure 4-2. Interface Connector

Table 4-1. Interface Signals

| Connector Pin No. | Circuit | | EIA Signal Name | Function |
|-------------------|---------|------------|-------------------------------|--|
| | EIA | C.C.I.T.T. | | |
| 1 | AA | 101 | Protective Ground | Connected to pin 7, signal ground. May be disconnected by removing a jumper inside the HyTerm. When this is done, pin 1 is left "floating." |
| 2 | BA | 103 | Transmitted Data | The serial, ASCII-coded digital data being transmitted by the HyTerm. This line is in the "mark" state (low) between characters, rises for logic 0 and drops for logic 1. |
| 3 | BB | 104 | Received Data | The serial, ASCII-coded digital data being received by the HyTerm. This line must be held in the "mark" state between characters, and should go high for logic 0, low for logic 1. |
| 4 | CA | 105 | Request to Send | Goes high whenever power is on. |
| 5 | CB | 106 | Clear to Send | Must be on (high) for HyTerm data transmission. If off, no data can be sent. (Remote mode). |
| 6 | CC | 107 | Data Set Ready | Must be on (high) for HyTerm operation. If off, no data can be received (Remote mode). |
| 7 | AB | 102 | Signal Ground | Ground reference for all other interface signals. |
| 8 | CF | 109 | Received Line Signal Detector | Carrier Detect. Not sampled by HyTerm. |
| 20 | CD | 108 | Data Terminal Ready | On (high) whenever HyTerm power is on. |
| 23 | CH | 111 | Data Signal Rate Selector | Not connected inside HyTerm. Included only for possible future use. |

4.4 CONNECTION TO THE MODEM

The cable connecting the HyTerm to the modem is approximately 10 feet (3 meters) long. It contains ten size 22 AWG conductors. It is permanently connected to the HyTerm internally, and exits from the rear. The modem end of the cable is terminated in a 25-pin subminiature connector, a Cannon or Cinch DB-25P, or AMP housing 205208-1 with 1-66506 pin inserts, or equivalent. This mates with the socket found on most modems, a Cannon or Cinch DB-25S, or AMP housing 205207-1 with socket contacts 1-66504 or 1-66505. The plug is enclosed in a hood (AMP 206472-1, or equivalent) to protect the plug wiring. Pin assignments are shown in Figure 4-2. (Note that this figure depicts the male connector on the end of the cable; the modem plugs would be a mirror image of this drawing.) See also Table 4-1.

Extension cables are available for use when the modem must be located more than ten feet from the HyTerm. Note, however, that the total length of all cables between the HyTerm and the modem should not exceed 50 feet (15 meters).

4.5 SIGNAL LEVELS

Signal voltages on the interface lines are nominally +12 and -12 volts. The EIA standard allows for voltages anywhere between +25 and -25 volts, and the HyTerm input receivers are capable of withstanding these levels. The actual values measured on the HyTerm output lines will be approximately 7 to 9 volts. Because of the possible wide variation in actual voltage levels, the nominal values of +12 and -12 will be used in this discussion.

Data signal states are referred to as "mark" and "space", where a mark denotes a logic 1 and space denotes a logic 0. All other signals (control signals) are referred to as either "on" or "off". Table 4-2 summarizes the relationship between these terms and their voltage levels.

Table 4-2. Interface Signal Terminology

| Data Circuits | Control Circuits | Nominal Voltage |
|---------------|------------------|-----------------|
| MARK ("1") | OFF | -12 |
| SPACE ("0") | ON | +12 |

Input receivers on the control lines provide "fail-safe" operation: if an input control line should go to ground level or be open-circuited (as when the connecting cable is unplugged), it will be interpreted as being "off". Data inputs are handled differently: if a data input is open-circuited, it will be interpreted as still being in the same state it was in previously. This provides greater noise immunity on the data input lines. This is illustrated in Figure 4-3, which also shows the actual voltages at which the transitions between states occur.

Note also in Figure 4-3 that the level at which the input signal changes from off to on (or from mark to space) is different from the level at which it changes back. This "hysteresis" provides additional noise immunity.

4.6 INTERFACE SIGNALS

The EIA signals wired to the interface connector are listed in Table 4-1.

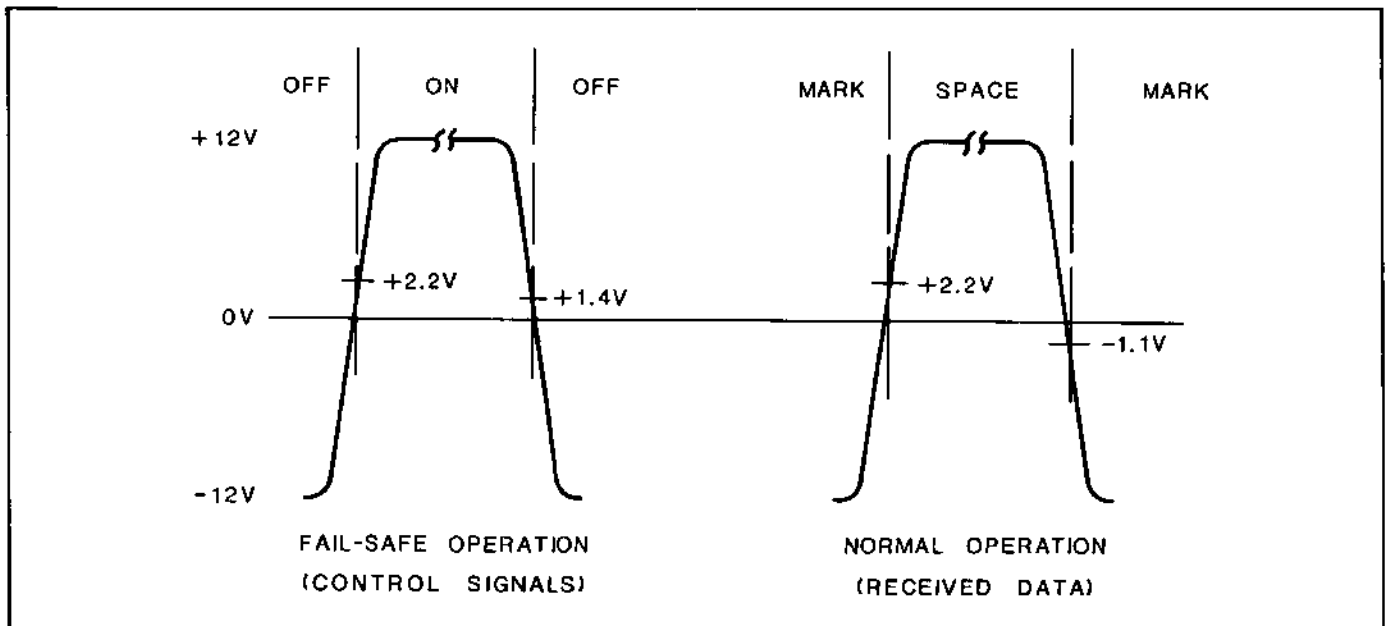

Figure 4-3. Input Line Switching Levels

4.7 DATA FORMAT

Figure 4-4 is an idealized representation of an ASCII character (K) on the Transmitted Data or Received Data lines. Voltage levels are nominally ± 12 volts. Timing varies depending upon the baud rate selected. The idle condition of the line is mark. The beginning of a character is noted by the initial transition from mark to space (the start bit). The seven data bits follow, least significant bit first. Then comes the parity bit, followed by the stop bit(s).

This figure shows even parity: the parity bit would be the opposite level for odd parity. If the PARITY switch on the control panel is set to MARK, the Received Data (pin 3) parity bit is not checked, and the Transmitted Data (pin 2) parity bit is always mark ("1" = low).

The illustration also shows the minimum spacing for both ten- and eleven-bit characters. Since this is asynchronous data transmission, the length of time between characters can vary from this minimum up to several seconds or more. Generally, computer-generated data will have only the minimum character spacing. Data generated by the HyTerm will have widely varying spaces between characters, depending upon the speed of the keyboard entry.

The coding system used for transmitted and received data is the USA Standard Code for Information Interchange (ASCII), standard no. X3.4-1977 of the American National Standards Institute, and standard no. ISO 646-1973 of the International Organization for Standardization. A code chart showing the bit configuration for each character is contained in Appendix A.

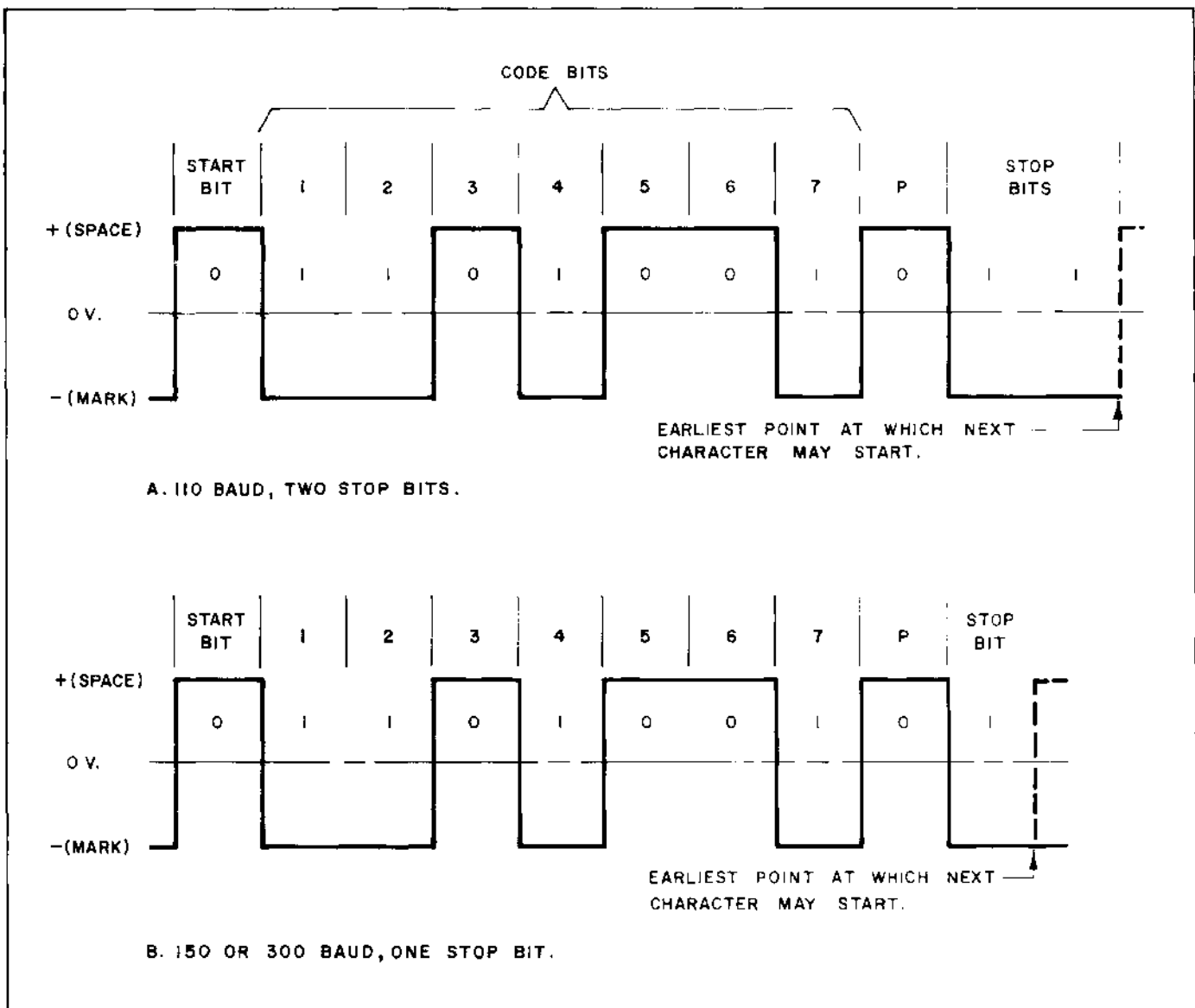

Figure 4-4. Data Format on Interface

4.8 TIMING

The timing between characters can vary greatly, as noted above. However, once a character has started, it must be completed at a definite rate, specified by the baud rate selected. Table 4-3 lists bit times and character times for the various baud rates.

Table 4-3. Interface Data Timing

| Baud Rate | Time in Milliseconds | |
|-----------|----------------------|-----------|
| | Bit | Character |
| 110 | 9.09 | 100 |
| 150 | 6.67 | 66.7 |
| 300 | 3.33 | 33.3 |
| 1200 | .83 | 8.3 |

4.9 CIRCUIT ELEMENTS

The three main circuit elements are the input level converter, the USART, and the output level converter. Information concerning the USART can be found in Section 4 of the Maintenance Manual.

4.9.1 Input Level Converter

The input level converter is used to change the $\pm 12V$ modem signals into +5V or 0V for use by the TTL logic inside the HyTerm. Type 75154 quad line receiver integrated circuits are used. The logic symbol, truth table, and representative waveforms are shown in Figure 4-5. "Normal" operation is provided for data inputs, and "fail-safe" operation is provided for control inputs. Input resistance is from 3K to 7K ohms, with 5K typical.

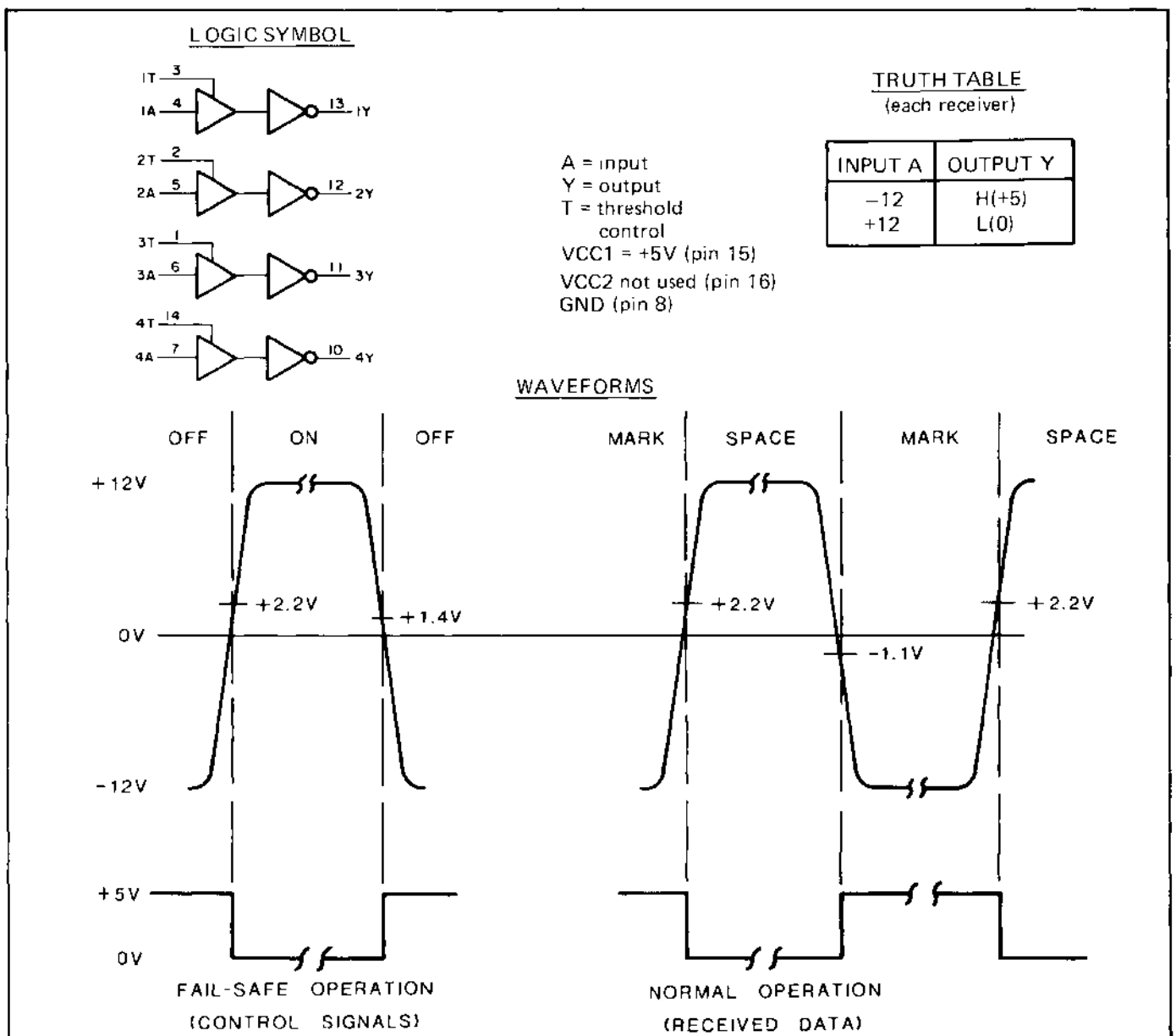

Figure 4-5. Input Converter IC

This device exhibits hysteresis on its inputs, which causes the output to switch at a different point on the input waveform depending upon whether the input is going from low-to-high or from high-to-low. This provides noise immunity by requiring the input signal to change considerably before it affects the output.

For normal operation, the threshold control terminal is connected to VCC1. This provides a wider hysteresis loop. In this mode of operation, if the input voltage goes to zero (or open-circuit), the output will remain either low (0V) or high (+5V) as determined by the previous input. For fail-safe operation, the threshold terminal is left floating. This reduces the hysteresis loop, causing the negative-going threshold to be above 0V. The positive-going threshold is unchanged. In this mode, if the input voltage goes to 0V or is open-circuited, the output goes high (+5V) regardless of the previous input condition.

4.9.2 Output Level Converter

The output level converter changes the TTL levels used internally by the HyTerm into levels suitable for use on the RS-232-C interface. Type 75150 line driver integrated circuits are used. The logic symbol and truth table are shown in Figure 4-6. Minimum output voltage is $\pm 5V$, typical is $\pm 8V$. This chip can withstand sustained output short circuits to any low-impedance voltage within the EIA range ($\pm 25V$).

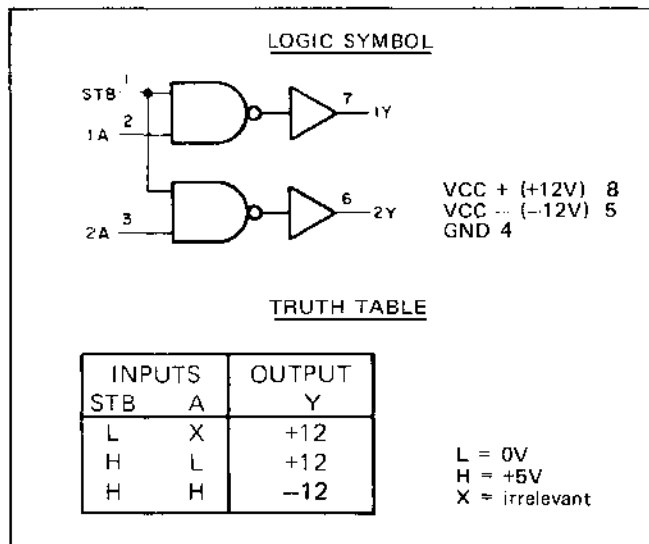

Figure 4-6. Output Converter IC

4.10 CURRENT LOOP INTERFACE

The current loop option provides a 20-60 mA current loop interface in place of the standard RS-232-C interface. This option requires an additional circuit board, designated HCURL (installed in board slot F), and a special interface cable assembly. Six different versions of the HCURL board are available as follows:

| | |
|----------|---------------------------|
| 23942-01 | Passive, half-duplex |
| 23942-02 | 20 mA active, full-duplex |
| 23942-03 | 20 mA active, half-duplex |
| 23942-04 | 60 mA active, full-duplex |
| 23942-05 | 60 mA active, half-duplex |
| 23942-99 | Passive, full-duplex |

The "passive" units will function with any external current-limited power source providing 20-60 mA.

The HCURL board fits electrically between the standard RS-232-C interface and the cable that interfaces the HyTerm to the rest of the current loop network. Either a 2-wire (half-duplex) or 4-wire (full-duplex) system up to 5000 feet (1524 meters) can be used. See section 5 for proper connections.

The interface cable is approximately 10 feet (3 meters) long. It contains several size 22 AWG conductors, and is permanently connected to the HyTerm internally. A 25-pin subminiature connector is used to interface the HyTerm to the communications network. This connector is a Cannon or Cinch DB-25P, or AMP housing 205208-1 with 1-66506 pin inserts, or equivalent. Mating connectors include the Cannon or Cinch DB-25S, or AMP housing 205207-1 with socket contacts 1-66504 or 1-66505. The plug is enclosed in a hood (AMP 206472-1, or equivalent). Pin assignments are shown in Figure 4-7. (Note that this figure depicts the male connector on the end of the cable; mating connectors would be a mirror image of the one shown.)

A "mark," or logic 1, is represented by current flow, and a "space," or logic 0, is represented by the absence of current flow (2 mA or less). During a mark condition (current flowing), the HyTerm introduces less than 280 ohms impedance to an external current driving source; during a space condition, the HyTerm inserts a minimum of 4K ohms impedance into the current loop.

Data format and timing are identical to that used for the RS-232-C interface. Refer to 4.7 and 4.8 for details."

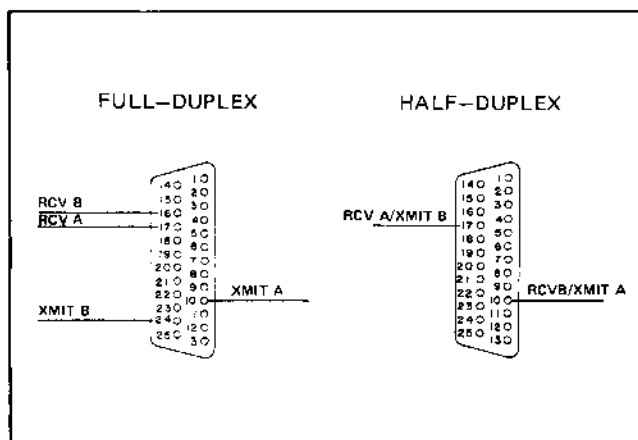

Figure 4-7. Current Loop Cable Pinout

SECTION 5 INSTALLATION

5.1 INTRODUCTION

In addition to unpacking and installation procedures, this section contains information on environmental requirements.

5.2 PRELIMINARY INSPECTION

Before unpacking the HyTerm from its shipping container, inspect the container for any obvious damage that may have occurred during shipment. If in-transit damage to the container is obvious, contact the carrier immediately. Do not open the container and remove the contents until the carrier's representative has inspected it.

5.3 UNPACKING AND INSPECTION

Follow the unpacking instructions attached to the shipping container. Different configurations of the HyTerm require slightly different unpacking procedures. Following is a list of items that are generally covered in the specific instructions, as well as a few general items that should also be observed:

- (1) During unpacking, be careful that tools being used do not inflict damage to the HyTerm.
- (2) As the HyTerm is unpacked, inspect it for damage. If a claim is to be filed for damages, save all of the original packing materials.
- (3) Remove packing material and any cartons of accessories from the container. Save all of the packing material if reshipment is anticipated.
- (4) Check all items as they are removed from the container against the packing list. Check the list of accessories to ensure that they have been received. Notify shipper of any shortages.
- (5) Remove the four restraining bolts threaded into the printer casting from the bottom. (Do NOT remove the four screws holding the casting to the shock mounts, at each corner of the printer.)
- (6) Cut and remove the shipping restraint that secures the printer carriage to the side frame.
- (7) Remove any tags, tape, etc., put on for shipping purposes.

CAUTION

Do not attempt to raise the HyTerm by lifting up on the paper rack attached to the top cover. This could break the cover and/or rack. Never tilt the HyTerm back on its rear heat sink, even with the top cover removed, for this could severely damage the electronic circuit boards.

5.4 SYSTEM REQUIREMENTS

The HyTerm may be easily and quickly installed. However, the operating environment, available space, and power requirements must also be considered.

5.4.1 Operating Environment

Section 1.3.4 shows the minimum and maximum operating and storage limits for temperature, humidity, and altitude.

5.4.2 Space Requirements

Very little space is required beyond the overall dimensions of the HyTerm, approximately 20 x 24 inches (depth x width). A minimum of 6 inches (15.2 cm) should be allowed on all sides for proper ventilation, making the minimum space requirements the following:

| | | |
|--------------|-----------|---------|
| Width | 36 inches | 92.4 cm |
| Depth (1620) | 26 inches | 66.0 cm |
| Depth (1610) | 22 inches | 55.9 cm |

5.4.3 Weight

| | | |
|-----|---------|----------|
| KSR | 48 lbs. | 21.8 kg. |
| RO | 43 lbs. | 19.5 kg. |

5.4.4 Power Requirements

The Hyterm operates 95 to 130V, or 190 to 260V, at 47-63 Hz, and consumes approximately 200 watts. A 12-foot (3.7-meter) power cord is provided.

5.5 INSTALLATION PROCEDURES

Installation of the HyTerm consists of plugging it into a power source, initial start-up and local checkout, connection to the modem, and initial verification of the remote data communications link.

During installation, Diablo Systems requests that special attention be given to the Installation Quality Report (IQR) card provided with all units shipped from the factory. Proper completion and prompt return of IQR cards aids Diablo Systems in its efforts to provide the customer with the highest standards of quality possible.

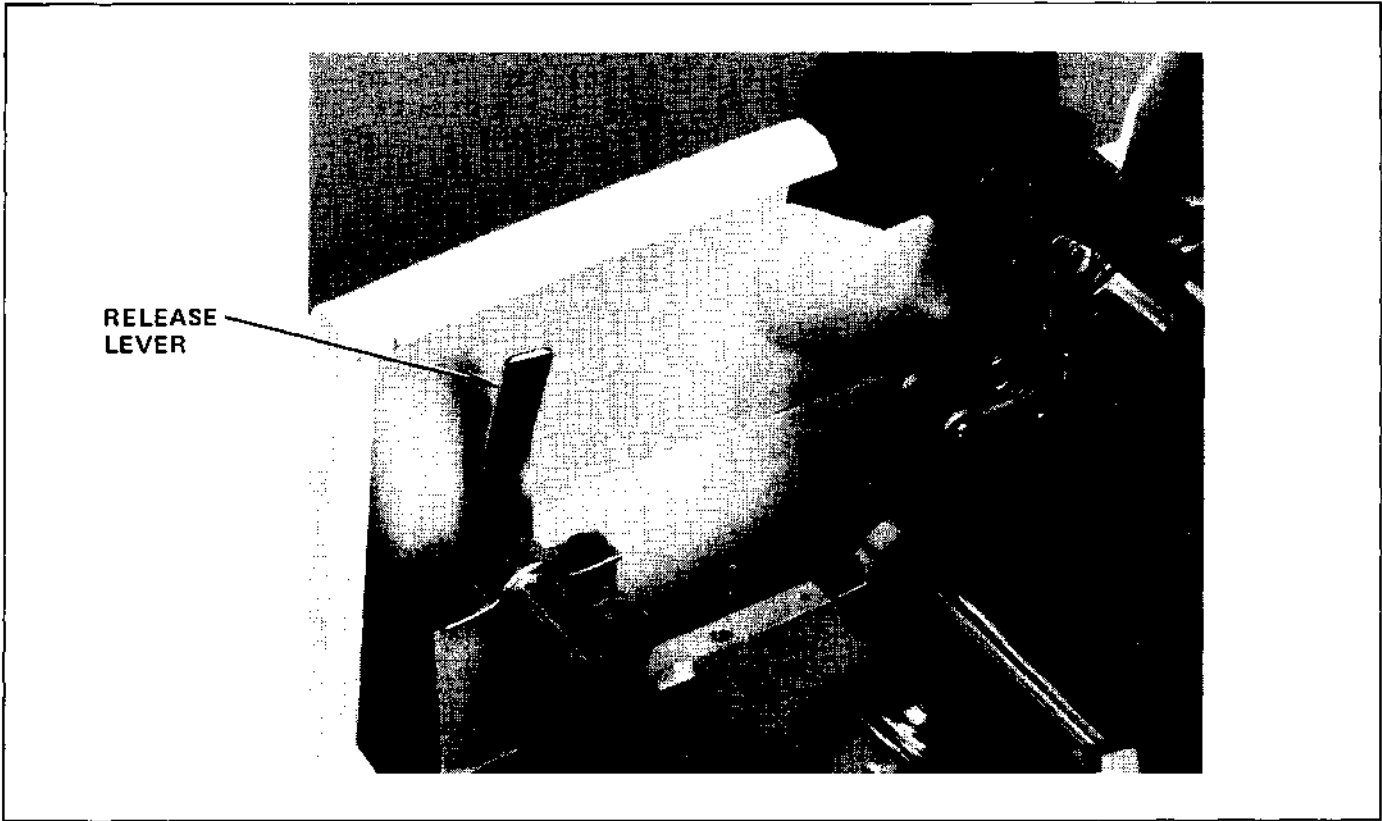

Figure 5-1. Top Cover Release Lever

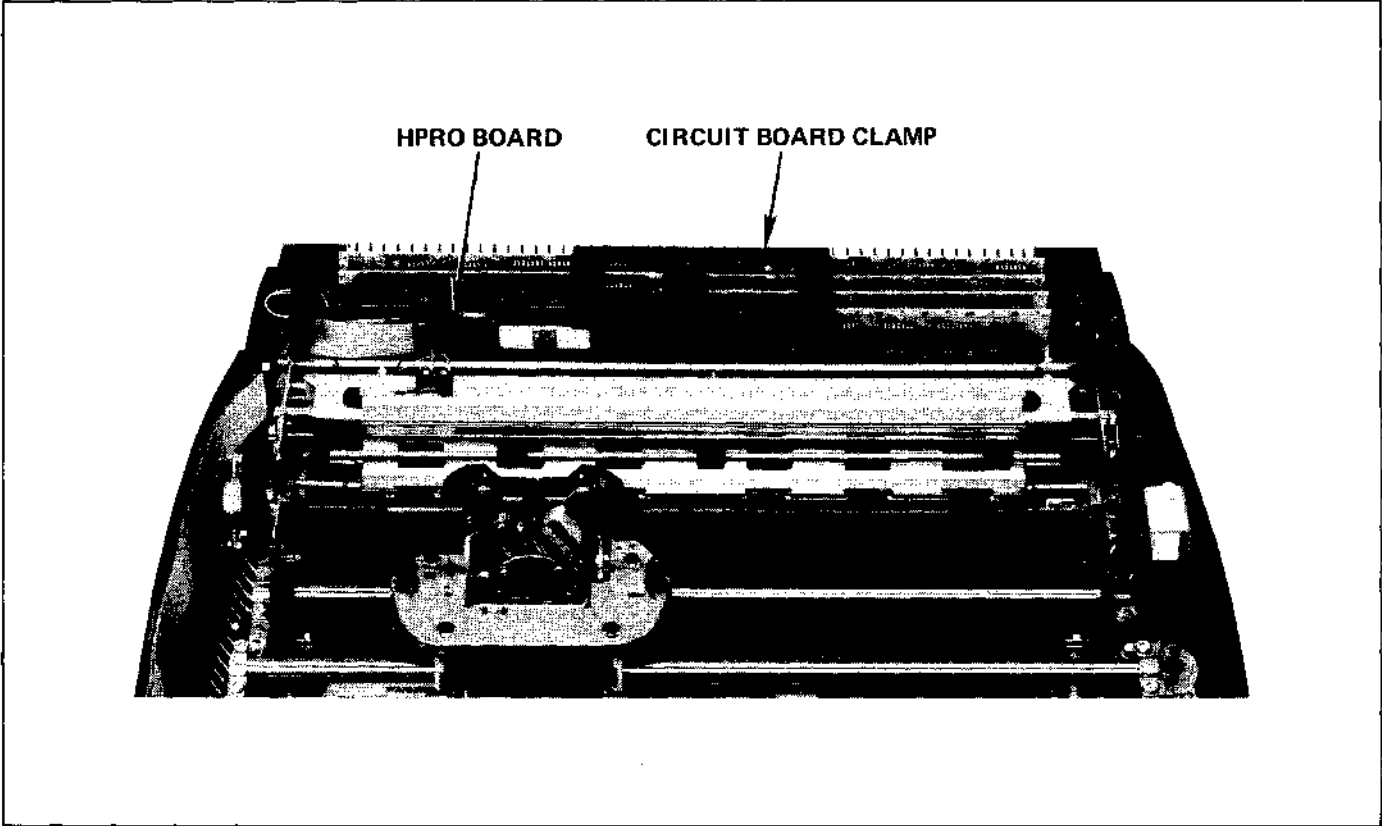

Figure 5-2. HPRO Board Location

5.5.1 Initial Start-up and Checkout

The HyTerm is ready for Local Mode operation as soon as the ac power cord is plugged into the facility power receptacle. Position the HyTerm so that its power cord will reach a suitable wall outlet. Do not use an extension cord.

On HyTerms factory wired for 220V operation, a plug must be added to the stub end of the power cord. Since many different styles of plugs are used in 220V power systems, the installer must obtain a plug suitable for use in each individual situation.

Bottom-feed HyTerms are shipped with the top-feed paper cradle not installed. This cradle must be left out for normal bottom-feed operation. It may be installed for top-feed paper use. To install, raise the access cover, remove the platen (see 2.4.3.1), and lay the cradle in place. Replace the platen and access cover.

Do not connect the EIA or current loop cable at this time. The HyTerm should be started up and checked locally before the capability for the Remote Mode operation is verified. If any trouble is encountered while performing these procedures, refer to the Error Recovery procedures in Section 2.3.4.

- (1) Set the POWER switch to the OFF position.
- (2) Make sure the printer access cover is closed.
- (3) Plug the ac power cord into the facility power receptacle and set the POWER switch to ON. The HyTerm should Clear when power is applied. A Clear is indicated by the carriage moving leftward slowly, hitting the left mechanical stop, then moving quickly about 1/5 inch to the right and stopping.
- (4) Depress the LOCAL key.
- (5) Insert a piece of paper in the printer. Type as desired on the keyboard until the carriage is some distance from its Clear position. Raise the access cover and depress the Clear pushbutton on the control panel. The HyTerm should Clear again. Close the access cover.
- (6) Operate all keys in Local mode to verify that they print or perform their function properly. Note: A small percentage of terminals may require printer adjustment to obtain optimum print quality after shipment. This is due to uncontrollable shipping and handling conditions after the units have left the factory.

5.5.2 Jumper Installation/Removal

It may be necessary to install one jumper and/or remove another. All jumpers are contained on the HPRO circuit

board. The HyTerm may come equipped with either of two versions of this board, HPRO1 or HPRO2. Both are functionally alike, but jumper locations are different. In addition, different revision levels of these boards require different jumper installation techniques. Most jumper installation requires soldering a 1/2-inch (1.2 cm) length of 26 AWG wire to the board. Jumper removal can be accomplished by unsoldering or simply by cutting the jumper. Later revision boards are equipped with a miniature socket for installation of the 1200 baud jumper; in this case a small shorting plug, Diablo part no. 10634, is simply plugged into the board or pulled out, instead of soldering or cutting a jumper.

To access the HPRO board, use the following procedure:

- (1) Make sure the power cord is disconnected from the wall.
- (2) Remove the forms tractor if one is installed.
- (3) Remove the platen (2.4.3.1).
- (4) Remove the printer top cover: release the two latches inside the cover at both sides, just in front of the platen (Figure 5-1), and lift the cover off. Set the cover safely aside.

CAUTION

Some HyTerms have the control panel switch assembly mounted to the top cover. If this is the case, be careful not to damage the connecting cable as the cover is set aside.

- (5) Using a Phillips screwdriver, remove the circuit board clamp by loosening the single screw in the center. See Figure 5-2.
- (6) Locate the HPRO board. See Figure 5-2. It is the front board (closest to the platen) on the left side. Remove the board by pulling it straight up. (When reinstalling this board, after the jumper work is completed, be certain to plug it back into the front slot — note that there may be one empty slot between the HPRO board and the next board.)

5.5.2.1 1200 BAUD

If 1200 baud operation is required, install a jumper or shorting plug as shown in Figure 5-3 and Table 5-1. In this mode, 1200 baud is the only speed available; the SPEED switch on the control panel has no effect.

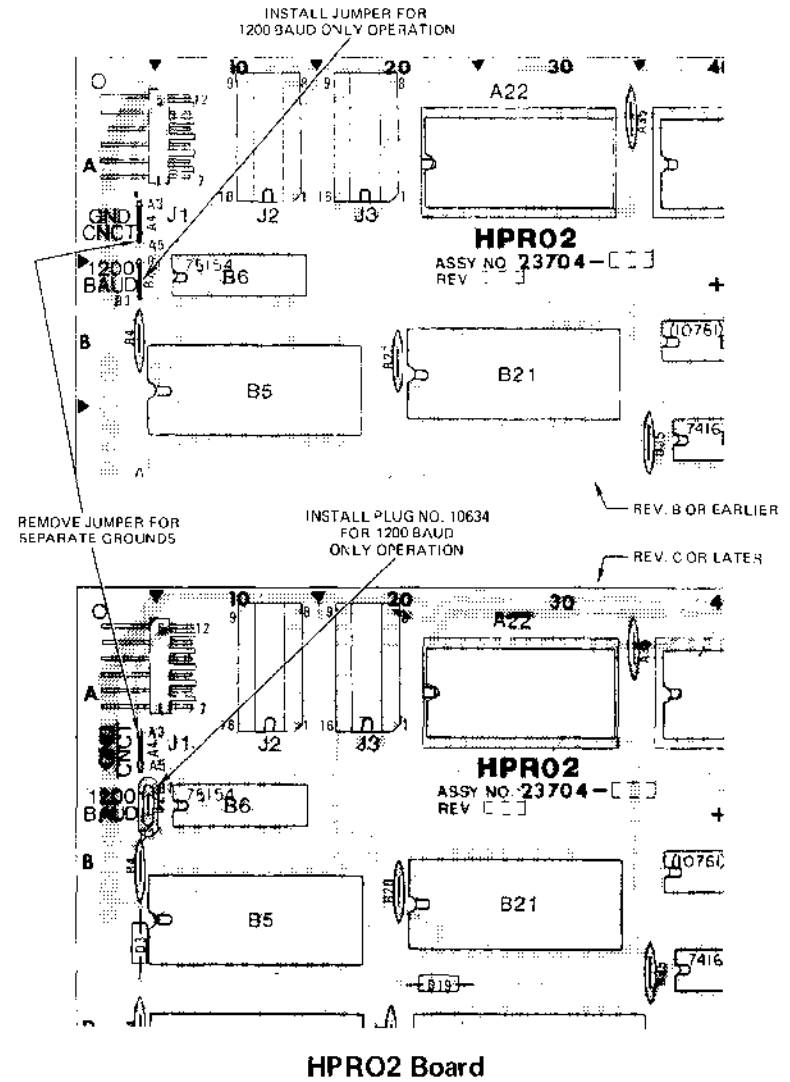
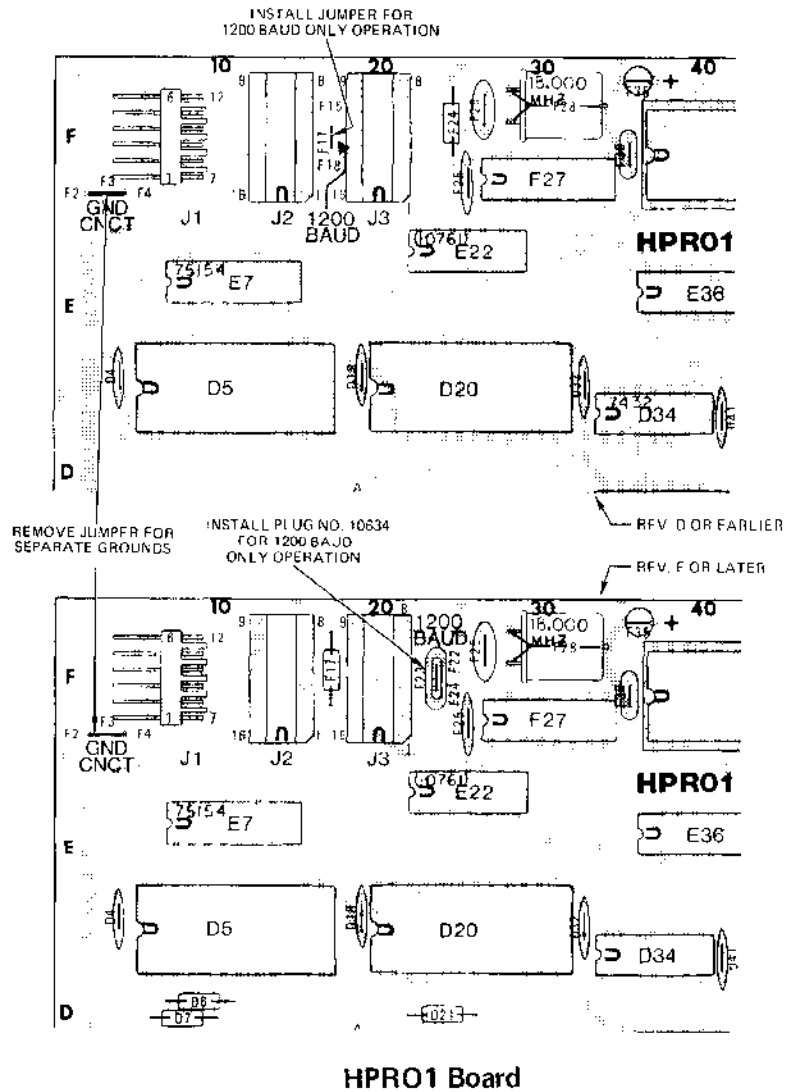

Figure 5-3. Jumper Location

5.5.2.2 GROUND DISCONNECT

Some modems require the Signal Ground (pin 7) and Protective Ground (pin 1) lines in the interface connector to be disconnected. If this is necessary, cut or remove jumper F3 on the HPRO1 board, or jumper A4 on the HPRO2 board. See Figure 5-3 and Table 5-1. Removal of this jumper leaves pin 1 of the interface connector (Protective Ground) floating.

5.5.2.3 Current Loop

Several versions of the HCURL board are provided to interface the HyTerm to different types of current loop networks. Should it be necessary to convert an HCURL board from one type of current loop operation to another, refer to schematic drawing no. 23942-XX for instructions.

Figure 5-4 shows the proper method of connecting the HyTerm to several different types of current-loop networks.

5.5.3 EIA Cable Connection and Remote Checkout

After the installation procedures of Section 5.5.1 have been completed, the EIA or current loop cable may be

connected. EIA extension cables are available should the modem be located more than ten feet from the HyTerm. In no case should the combined length of all cables between the HyTerm and the modem exceed 50 feet (15 meters). Use the following procedure:

- (1) Plug the cable into the modem data receptacle. Make sure that the plug is firmly seated; use a screwdriver to tighten the screws. If cable extensions are used, make sure they are fastened securely.
- (2) Connect ac power to the modem in accordance with the instructions contained with the modem being used.
- (3) Establish a remote data communications link. Refer to Operating Instructions, Section 2.3.3. If any trouble is encountered, refer to Section 2.3.4, Error Recovery.

5.6 REPACKAGING FOR SHIPMENT

To repackage a HyTerm, some of the original packing materials may be reused, such as the main container and the individual containers for accessories. However, accordion-type cardboard fillers may not be suitable after one shipment if the cushioning qualities are gone. Also, the carriage must be secured to the printer side frame using a new 8" nylon tie, Diablo part no. 10967-02 or equivalent.

Table 5-1. Jumper/Shorting Plug Location

| Option | Circuit Board | | | |
|----------------|-------------------|-----------------|-------------------|-----------------|
| | HPRO1 | | HPRO2 | |
| | Rev. D or Earlier | Rev. E Or Later | Rev. B or Earlier | Rev. C or Later |
| 1200 Baud | Jumper F17 | Plug F23 | Jumper B2 | Plug B2 |
| GND Disconnect | Jumper F3 | | Jumper A4 | |

Use 26 AWG wire for jumpers; use Diablo part No. 10634 for plug.

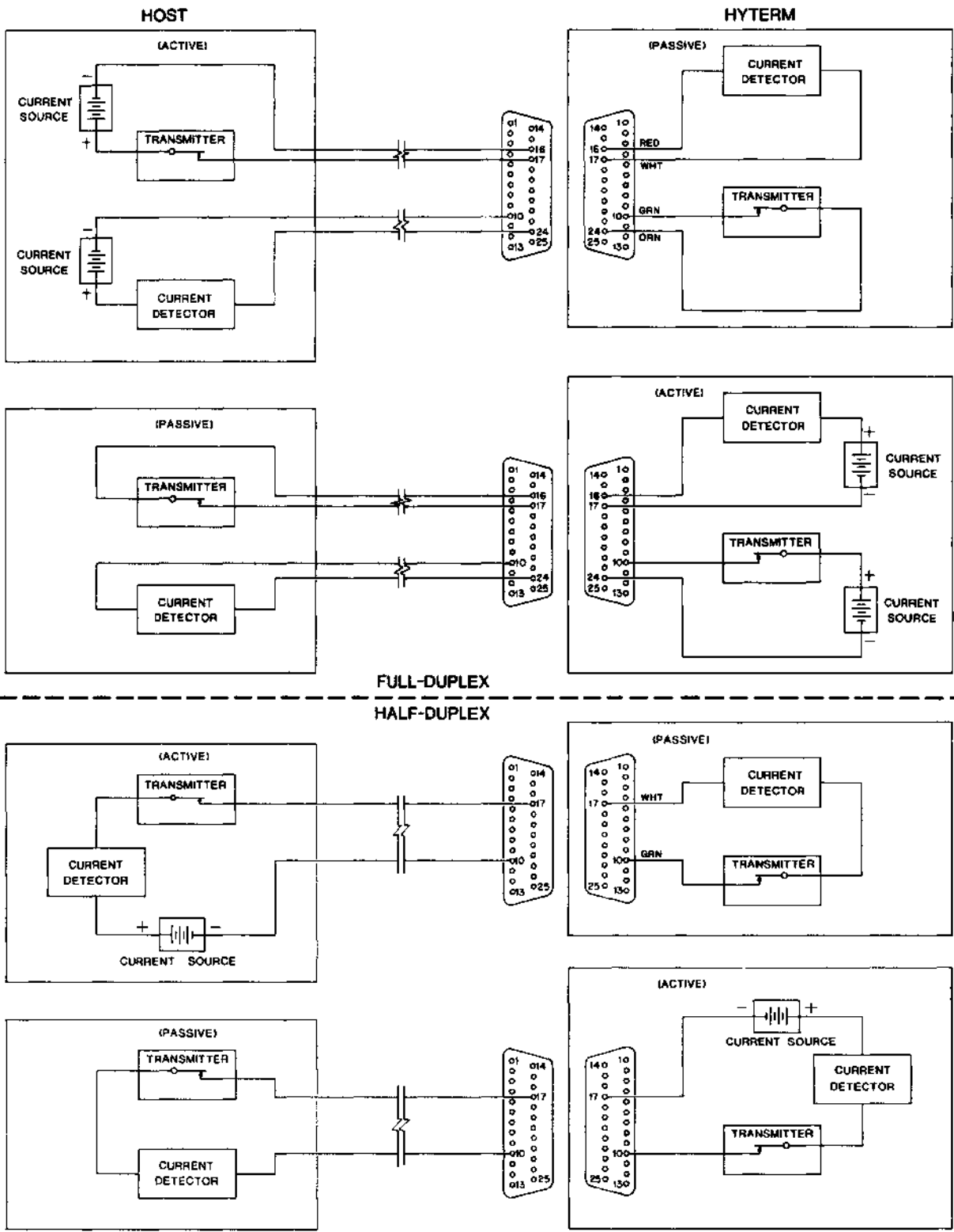

332-001

Figure 5-4. Current Loop Connections

APPENDIX A
ASCII CODE CHART

1977 ASCII: American Standard Code for Information Interchange. Standard No. X3.4-1977 of the American National Standards Institute.

| Bits | | b7 → | 0 | 0 | 0 | 0 | 1 | 1 | 1 | 1 | | |
|------|------|------|------|----------|-----|---------|----|---|---|---|---|-----|
| | | b6 → | 0 | 0 | 1 | 1 | 0 | 0 | 1 | 1 | | |
| | | b5 → | 0 | 1 | 0 | 1 | 0 | 1 | 0 | 1 | | |
| b4 ↓ | b3 ↓ | b2 ↓ | b1 ↓ | COLUMN → | | ↑ ROW ↓ | | | | | | |
| | | | | 0 | 1 | 2 | 3 | 4 | 5 | 6 | 7 | |
| 0 | 0 | 0 | 0 | 0 | NUL | DLE | SP | 0 | @ | P | ' | p |
| 0 | 0 | 0 | 1 | 1 | SOH | DC1 | ! | 1 | A | Q | a | q |
| 0 | 0 | 1 | 0 | 2 | STX | DC2 | " | 2 | B | R | b | r |
| 0 | 0 | 1 | 1 | 3 | ETX | DC3 | # | 3 | C | S | c | s |
| 0 | 1 | 0 | 0 | 4 | EOT | DC4 | \$ | 4 | D | T | d | t |
| 0 | 1 | 0 | 1 | 5 | ENQ | NAK | % | 5 | E | U | e | u |
| 0 | 1 | 1 | 0 | 6 | ACK | SYN | & | 6 | F | V | f | v |
| 0 | 1 | 1 | 1 | 7 | BEL | ETB | ' | 7 | G | W | g | w |
| 1 | 0 | 0 | 0 | 8 | BS | CAN | (| 8 | H | X | h | x |
| 1 | 0 | 0 | 1 | 9 | HT | EM |) | 9 | I | Y | i | y |
| 1 | 0 | 1 | 0 | 10 | LF | SUB | * | : | J | Z | j | z |
| 1 | 0 | 1 | 1 | 11 | VT | ESC | + | ; | K | L | k | { |
| 1 | 1 | 0 | 0 | 12 | FF | FS | , | < | L | \ | l | ! |
| 1 | 1 | 0 | 1 | 13 | CR | GS | - | = | M |] | m | } |
| 1 | 1 | 1 | 0 | 14 | SO | RS | . | > | N | ^ | n | ~ |
| 1 | 1 | 1 | 1 | 15 | SI | US | / | ? | O | _ | o | DEL |

All characters in these two columns and SP (Space) are non-printing. DEL (Delete) does not print in Remote mode, but prints logical NOT symbol (¬) when entered on keyboard in Local mode. (Logical NOT is also printed in place of characters received with parity or framing error.)

When UPPER CASE ONLY is used, shaded lower case characters (columns 6 & 7) from keyboard are converted to their upper case equivalents (columns 4 & 5) before being printed or transmitted. Additional characters are converted when certain European keyboards are used. Refer to keyboard layouts.

APPENDIX B KEYBOARD LAYOUTS AND CODE CHARTS

46-KEY TYPEWRITER PAIRING KEYBOARD (Available with or without 10-key numeric pad.)

Position Numbers above keytops refer to accompanying code chart table. Control codes and special symbols referenced below keytops identify "CTRL" mode output. These legends are not engraved on keytops.

100% compatible printwheels:

- 38100 Courier 10
- 38107 Courier 72
- 38101 Pica 10
- 38102 Elite 12

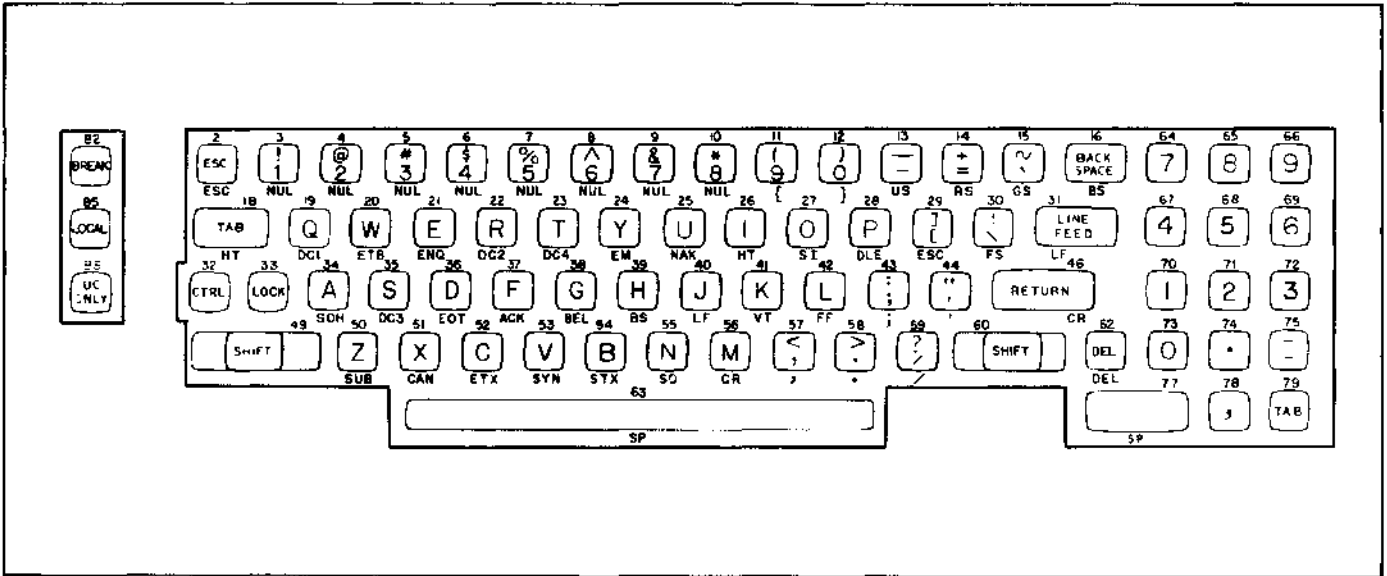

APPENDIX B (Continued)
KEYBOARD LAYOUTS AND CODE CHARTS

46-Key Typewriter Pairing

| KEY POSITION | UNSHIFTED MODE | ASCII CODE (HEXADECIMAL) | SHIFTED MODE | ASCII CODE | CONTROL MODE | ASCII CODE |
|--------------|----------------|--------------------------|--------------|------------|--------------|------------|
| 1 | NUL | 00 | NUL | 00 | NUL | 00 |
| 2 | ESC | 1B | ESC | 1B | ESC | 1B |
| 3 | 1 | 31 | ! | 21 | NUL | 00 |
| 4 | 2 | 32 | @ | 40 | NUL | 00 |
| 5 | 3 | 33 | # | 23 | NUL | 00 |
| 6 | 4 | 34 | \$ | 24 | NUL | 00 |
| 7 | 5 | 35 | % | 25 | NUL | 00 |
| 8 | 6 | 36 | ^ | 5E | NUL | 00 |
| 9 | 7 | 37 | & | 26 | NUL | 00 |
| 10 | 8 | 38 | * | 2A | NUL | 00 |
| 11 | 9 | 39 | (| 28 | { | 7B |
| 12 | 0 | 30 |) | 29 | } | 7D |
| 13* | - | 2D | _ | 5F | US | 1F |
| 14 | = | 3D | + | 2B | RS | 1E |
| 15 | . | 60 | - | 7E | GS | 1D |
| 16* | BS | 08 | BS | 08 | BS | 08 |
| 17 | NUL | 00 | NUL | 00 | NUL | 00 |
| 18 | HT | 09 | HT | 09 | HT | 09 |
| 19 | q | 71 | Q | 51 | DC1 | 11 |
| 20 | w | 77 | W | 57 | ETB | 17 |
| 21 | e | 65 | E | 45 | ENQ | 05 |
| 22 | r | 72 | R | 52 | DC2 | 12 |
| 23 | t | 74 | T | 54 | DC4 | 14 |
| 24 | y | 79 | Y | 59 | EM | 19 |
| 25 | u | 75 | U | 55 | NAK | 15 |
| 26 | i | 69 | I | 49 | HT | 09 |
| 27 | o | 6F | O | 4F | SI | 0F |
| 28 | p | 70 | P | 50 | DLE | 10 |
| 29 | [| 5B | | 5D | ESC | 1B |
| 30 | \ | 5C |] | 7C | FS | 1C |
| 31* | LF | 0A | LF | 0A | LF | 0A |
| 32 | CTRL | | | | | |
| 33 | LOCK | | | | | |
| 34 | a | 61 | A | 41 | SOH | 01 |
| 35 | s | 73 | S | 53 | DC3 | 13 |
| 36 | d | 64 | D | 44 | EOT | 04 |
| 37 | f | 66 | F | 46 | ACK | 06 |
| 38 | g | 67 | G | 47 | BEL | 07 |
| 39 | h | 68 | H | 48 | BS | 08 |
| 40 | j | 6A | J | 4A | LF | 0A |
| 41 | k | 6B | K | 4B | VT | 0B |
| 42 | l | 6C | L | 4C | FF | 0C |
| 43 | ; | 3B | : | 3A | : | 3B |
| 44 | ' | 27 | " | 22 | ' | 27 |
| 45 | : | 7B | } | 7D | GS | 1D |
| 46* | CR | 0D | CR | 0D | CR | 0D |
| 47 | CTRL | | | | | |
| 48 | Function | | | | | |
| 49 | SHIFT | | | | | |
| 50 | z | 7A | Z | 5A | SUB | 1A |
| 51 | x | 78 | X | 58 | CAN | 18 |
| 52 | c | 63 | C | 43 | ETX | 03 |
| 53 | v | 76 | V | 56 | SYN | 16 |
| 54 | b | 62 | B | 42 | STX | 02 |
| 55 | n | 6E | N | 4E | SO | 0E |
| 56 | m | 6D | M | 4D | CR | 0D |
| 57 | , | 2C | < | 3C | , | 2C |
| 58* | . | 2E | > | 3E | . | 2E |
| 59 | / | 2F | ? | 3F | / | 2F |
| 60 | SHIFT | | | | | |
| 61 | NUL | 00 | NUL | 00 | NUL | 00 |
| 62 | DEL | 7F | DEL | 7F | DEL | 7F |
| 63* | SP | 20 | SP | 20 | SP | 20 |
| 64 | 7 | 37 | 7 | 37 | 7 | 37 |
| 65 | 8 | 38 | 8 | 38 | 8 | 38 |
| 66 | 9 | 39 | 9 | 39 | 9 | 39 |
| 67 | 4 | 34 | 4 | 34 | 4 | 34 |
| 68 | 5 | 35 | 5 | 35 | 5 | 35 |
| 69 | 6 | 36 | 6 | 36 | 6 | 36 |
| 70 | 1 | 31 | 1 | 31 | 1 | 31 |
| 71 | 2 | 32 | 2 | 32 | 2 | 32 |
| 72 | 3 | 33 | 3 | 33 | 3 | 33 |
| 73 | 0 | 30 | 0 | 30 | 0 | 30 |
| 74 | . | 2E | . | 2E | . | 2E |
| 75 | - | 2D | - | 2D | - | 2D |
| 76 | EOT | 04 | EOT | 04 | EOT | 04 |
| 77* | SP | 20 | SP | 20 | SP | 20 |
| 78 | , | 2C | , | 2C | , | 2C |
| 79 | HT | 09 | HT | 09 | HT | 09 |

*Denotes Repeat Keys

**APPENDIX B (Cont'd.)
KEYBOARD LAYOUTS AND CODE CHARTS**

47-KEY LOGICAL BIT PAIRING KEYBOARD

Position numbers above keytops refer to accompanying code chart table. Control codes and special symbols referenced below keytops identify "CTRL" mode output. These legends are not engraved on keytops.

100% compatible printwheels:

- 38100 Courier 10
- 38107 Courier 72
- 38101 Pica 10
- 38102 Elite 12

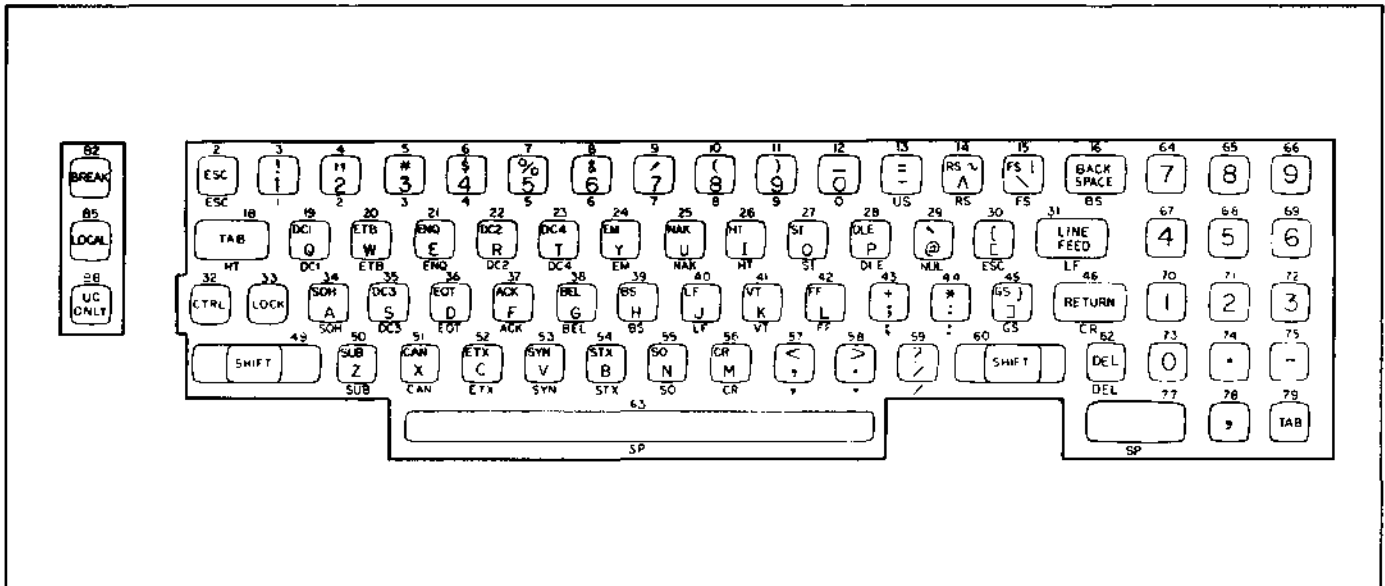

APPENDIX B (Continued)

KEYBOARD LAYOUTS AND CODE CHARTS

47-KEY LOGICAL BIT PAIRING

| KEY POSITION | UNSHIFTED MODE | ASCII CODE (HEXADECIMAL) | SHIFTED MODE | ASCII CODE | CONTROL MODE | ASCII CODE |
|--------------|----------------|-----------------------------|--------------|------------|--------------|------------|
| 1 | LF | 0A | LF | 0A | LF | 0A |
| 2 | ESC | 1B | ESC | 1B | ESC | 1B |
| 3 | 1 | 31 | ! | 21 | * 1 | 31 |
| 4 | 2 | 32 | " | 22 | 2 | 32 |
| 5 | 3 | 33 | # | 23 | 3 | 33 |
| 6 | 4 | 34 | \$ | 24 | 4 | 34 |
| 7 | 5 | 35 | % | 25 | 5 | 35 |
| 8 | 6 | 36 | & | 26 | 6 | 36 |
| 9 | 7 | 37 | ' | 27 | 7 | 37 |
| 10 | 8 | 38 | (| 28 | 8 | 38 |
| 11 | 9 | 39 |) | 29 | 9 | 39 |
| 12* | 0 | 30 | _ | 5F | 0 | 30 |
| 13* | - | 2D | ~ | 3D | US | 1F |
| 14 | ` | 5E | | 7E | RS | 1E |
| 15 | \ | 5C | | 7C | FS | 1C |
| 16* | BS | 08 | BS | 08 | BS | 08 |
| 17 | NUL | 00 | NUL | 00 | NUL | 00 |
| 18 | HT | 09 | HT | 09 | HT | 09 |
| 19 | q | 71 | Q | 51 | DC1 | 11 |
| 20 | w | 77 | W | 57 | ETB | 17 |
| 21 | e | 65 | E | 45 | ENQ | 05 |
| 22 | r | 72 | R | 52 | DC2 | 12 |
| 23 | t | 74 | T | 54 | DC4 | 14 |
| 24 | y | 79 | Y | 59 | EM | 19 |
| 25 | u | 75 | U | 55 | NAK | 15 |
| 26 | i | 69 | I | 49 | HT | 09 |
| 27 | o | 6F | O | 4F | SI | 0F |
| 28 | p | 70 | P | 50 | DLE | 10 |
| 29 | @ | 40 | ~ | 60 | NUL | 00 |
| 30 | [| 58 | { | 7B | ESC | 1B |
| 31* | LF | 0A | LF | 0A | LF | 0A |
| 32 | CTRL | | | | | |
| 33 | LOCK | | | | | |
| 34 | a | 61 | A | 41 | SOH | 01 |
| 35 | s | 73 | S | 53 | DC3 | 13 |
| 36 | d | 64 | D | 44 | EOT | 04 |
| 37 | f | 66 | F | 46 | ACK | 06 |
| 38 | g | 67 | G | 47 | BEL | 07 |
| 39 | h | 68 | H | 48 | BS | 08 |
| 40 | j | 6A | J | 4A | LF | 0A |
| 41 | k | 6B | K | 4B | VT | 0B |
| 42 | l | 6C | L | 4C | FF | 0C |
| 43 | ; | 3B | + | 2B | ; | 3B |
| 44 | : | 3A | * | 2A | : | 3A |
| 45 |] | 5D | } | 7D | GS | 1D |
| 46* | CR | 0D | CR | 0D | CR | 0D |
| 47 | CTRL | | | | | |
| 48 | Function | | | | | |
| 49 | SHIFT | | | | | |
| 50 | z | 7A | Z | 5A | SUB | 1A |
| 51 | x | 78 | X | 58 | CAN | 18 |
| 52 | c | 63 | C | 43 | ETX | 03 |
| 53 | v | 76 | V | 56 | SYN | 16 |
| 54 | b | 62 | B | 42 | STX | 02 |
| 55 | n | 6E | N | 4E | SO | 0E |
| 56 | m | 6D | M | 4D | CR | 0D |
| 57 | , | 2C | < | 3C | , | 2C |
| 58* | . | 2E | > | 3E | . | 2E |
| 59 | / | 2F | ? | 3F | / | 2F |
| 60 | SHIFT | | | | | |
| 61 | DEL | 7F | DEL | 7F | DEL | 7F |
| 62 | DEL | 7F | DEL | 7F | DEL | 7F |
| 63* | SP | 20 | SP | 20 | SP | 20 |
| 64 | 7 | 37 | 7 | 37 | 7 | 37 |
| 65 | 8 | 38 | 8 | 38 | 8 | 38 |
| 66 | 9 | 39 | 9 | 39 | 9 | 39 |
| 67 | 4 | 34 | 4 | 34 | 4 | 34 |
| 68 | 5 | 35 | 5 | 35 | 5 | 35 |
| 69 | 6 | 36 | 6 | 36 | 6 | 36 |
| 70 | 1 | 31 | 1 | 31 | 1 | 31 |
| 71 | 2 | 32 | 2 | 32 | 2 | 32 |
| 72 | 3 | 33 | 3 | 33 | 3 | 33 |
| 73 | 0 | 30 | 0 | 30 | 0 | 30 |
| 74 | . | 2E | . | 2E | . | 2E |
| 75 | - | 2D | - | 2D | - | 2D |
| 76 | DEL | 7F | DEL | 7F | DEL | 7F |
| 77* | SP | 20 | SP | 20 | SP | 20 |
| 78 | , | 2C | , | 2C | , | 2C |
| 79 | HT | 09 | HT | 09 | HT | 09 |

*Denotes Repeat Keys

**APPENDIX B (Cont'd.)
KEYBOARD LAYOUTS AND CODE CHARTS**

FRENCH QWERTY

Position Numbers above keytops refer to accompanying code chart table. Control codes and special symbols referenced below keytops identify "CTRL" mode output. These legends are not engraved on key tops.

100% compatible printwheels:

38131 French Prestige Cubic

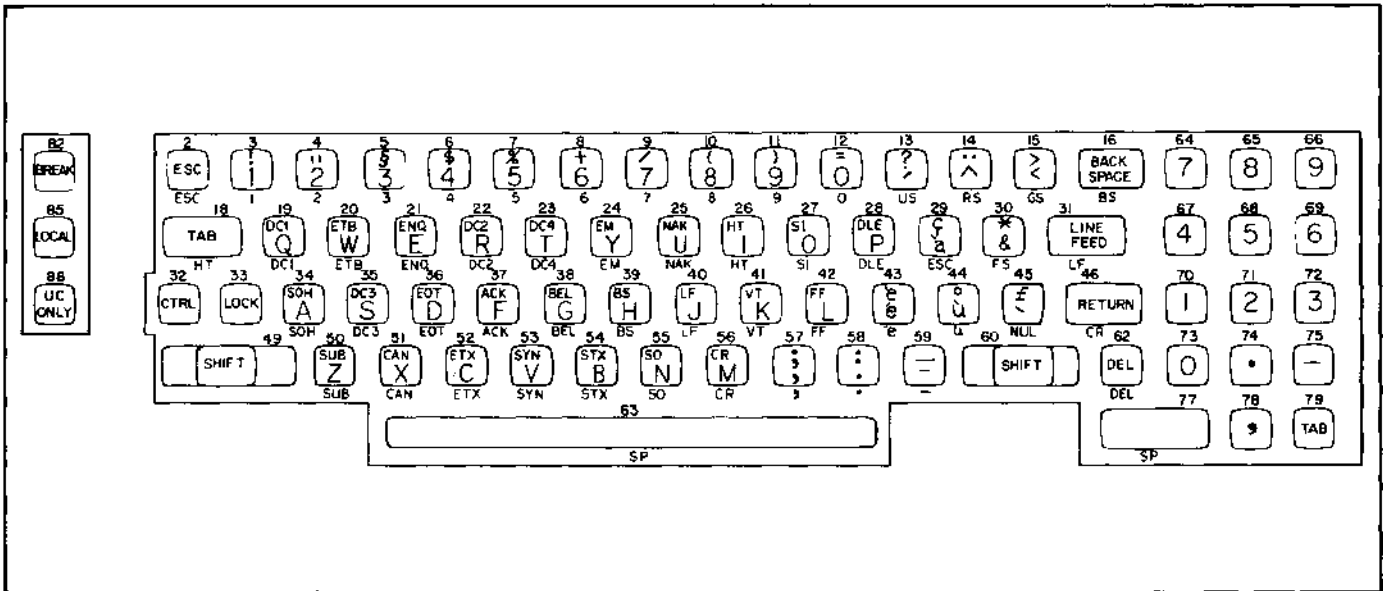

APPENDIX B (Continued)
KEYBOARD LAYOUTS AND CODE CHARTS

FRENCH QWERTY

| KEY POSITION | UNSHIFTED MODE | ASCII CODE (HEXADECIMAL) | SHIFTED MODE | ASCII CODE | CONTROL MODE | ASCII CODE |
|--------------|----------------|--------------------------|--------------|------------|--------------|------------|
| 1 | NUL | 00 | NUL | 00 | NUL | 00 |
| 2 | ESC | 1B | ESC | 1B | ESC | 1B |
| 3 | ! | 21 | ! | 21 | I | 31 |
| 4 | " | 22 | " | 22 | 2 | 32 |
| 5 | # | 23 | # | 23 | 3 | 33 |
| 6 | \$ | 24 | \$ | 24 | 4 | 34 |
| 7 | % | 25 | % | 25 | 5 | 35 |
| 8 | + | 2B | + | 2B | 6 | 36 |
| 9 | / | 2F | / | 2F | 7 | 37 |
| 10 | (| 28 | (| 28 | 8 | 38 |
| 11 |) | 29 |) | 29 | 9 | 39 |
| 12* | = | 3D | = | 3D | 0 | 30 |
| 13* | ? | 3F | ? | 3F | US | 1F |
| 14 | ~ | 5E | ~ | 7E | RS | 1E |
| 15 | < | 3C | > | 3E | GS | 1D |
| 16* | BS | 08 | BS | 08 | BS | 08 |
| 17 | NUL | 00 | NUL | 00 | NUL | 00 |
| 18 | HT | 09 | HT | 09 | HT | 09 |
| 19 | q | 71 | Q | 51 | DC1 | 11 |
| 20 | w | 77 | W | 57 | ETB | 17 |
| 21 | e | 65 | E | 45 | FNQ | 05 |
| 22 | r | 72 | R | 52 | DC2 | 12 |
| 23 | t | 74 | T | 54 | DC4 | 14 |
| 24 | y | 79 | Y | 59 | EM | 19 |
| 25 | u | 75 | U | 55 | NAK | 15 |
| 26 | i | 69 | I | 49 | HT | 09 |
| 27 | o | 6F | O | 4F | SI | 0F |
| 28 | p | 70 | P | 50 | DLE | 10 |
| 29 | à | 40 | ç | 5C | FSC | 1B |
| 30 | & | 26 | * | 2A | FS | 1C |
| 31* | LF | 0A | LF | 0A | LF | 0A |
| 32 | CTRL | | | | | |
| 33 | LOCK | | | | | |
| 34 | a | 61 | A | 41 | SOH | 01 |
| 35 | s | 73 | S | 53 | DC3 | 13 |
| 36 | d | 64 | D | 44 | EOT | 04 |
| 37 | f | 66 | F | 46 | ACK | 06 |
| 38 | g | 67 | G | 47 | BEL | 07 |
| 39 | h | 68 | H | 48 | BS | 08 |
| 40 | j | 6A | J | 4A | LF | 0A |
| 41 | k | 6B | K | 4B | VT | 0B |
| 42 | l | 6C | L | 4C | FF | 0C |
| 43 | é | 7B | è | 7D | é | 7A |
| 44 | ù | 7C | ° | 5B | ù | 7C |
| 45 | · | 6D | ↓ | 23 | NUL | 00 |
| 46* | CR | 0D | CR | 0D | CR | 0D |
| 47 | CTRL | | | | | |
| 48 | Function | | | | | |
| 49 | SHIFT | | | | | |
| 50 | z | 7A | Z | 5A | SUB | 1A |
| 51 | x | 78 | X | 58 | CAN | 18 |
| 52 | c | 63 | C | 43 | ETX | 03 |
| 53 | v | 76 | V | 56 | SYN | 16 |
| 54 | b | 62 | B | 42 | STX | 02 |
| 55 | n | 6E | N | 4E | SO | 0E |
| 56 | m | 6D | M | 4D | CR | 0D |
| 57 | , | 2C | ; | 3B | , | 2C |
| 58* | . | 2E | : | 3A | . | 2E |
| 59 | - | 2D | _ | 5F | - | 2D |
| 60 | SHIFT | | | | | |
| 61 | NUL | 00 | NUL | 00 | NUL | 00 |
| 62 | DEL | 7F | DEL | 7F | DFI | 7F |
| 63* | SP | 20 | SP | 20 | SP | 20 |
| 64 | / | 37 | 7 | 37 | 7 | 37 |
| 65 | 8 | 38 | 8 | 38 | 8 | 38 |
| 66 | 9 | 39 | 9 | 39 | 9 | 39 |
| 67 | 4 | 34 | 4 | 34 | 4 | 34 |
| 68 | 5 | 35 | 5 | 35 | 5 | 35 |
| 69 | 6 | 36 | 6 | 36 | 6 | 36 |
| 70 | . | 31 | 1 | 31 | 1 | 31 |
| 71 | 2 | 32 | 2 | 32 | 2 | 32 |
| 72 | 3 | 33 | 3 | 33 | 3 | 33 |
| 73 | 0 | 30 | 0 | 30 | 0 | 30 |
| 74 | . | 2E | . | 2E | . | 2E |
| 75 | - | 2D | - | 2D | - | 2D |
| 76 | EOT | 04 | EOT | 04 | EOT | 04 |
| 77* | SP | 20 | SP | 20 | SP | 20 |
| 78 | , | 2C | , | 2C | , | 2C |
| 79 | HT | 09 | HT | 09 | HT | 09 |

*Denotes Repeat Keys

**APPENDIX B (Cont'd.)
KEYBOARD LAYOUTS AND CODE CHARTS**

FRENCH AZERTY

Position Numbers above keytops refer to accompanying code chart table. Control codes and special symbols referenced below keytops identify "CTRL" mode output. These legends are not engraved on keytops.

100% compatible printwheels:

38131 French Prestige Cubic

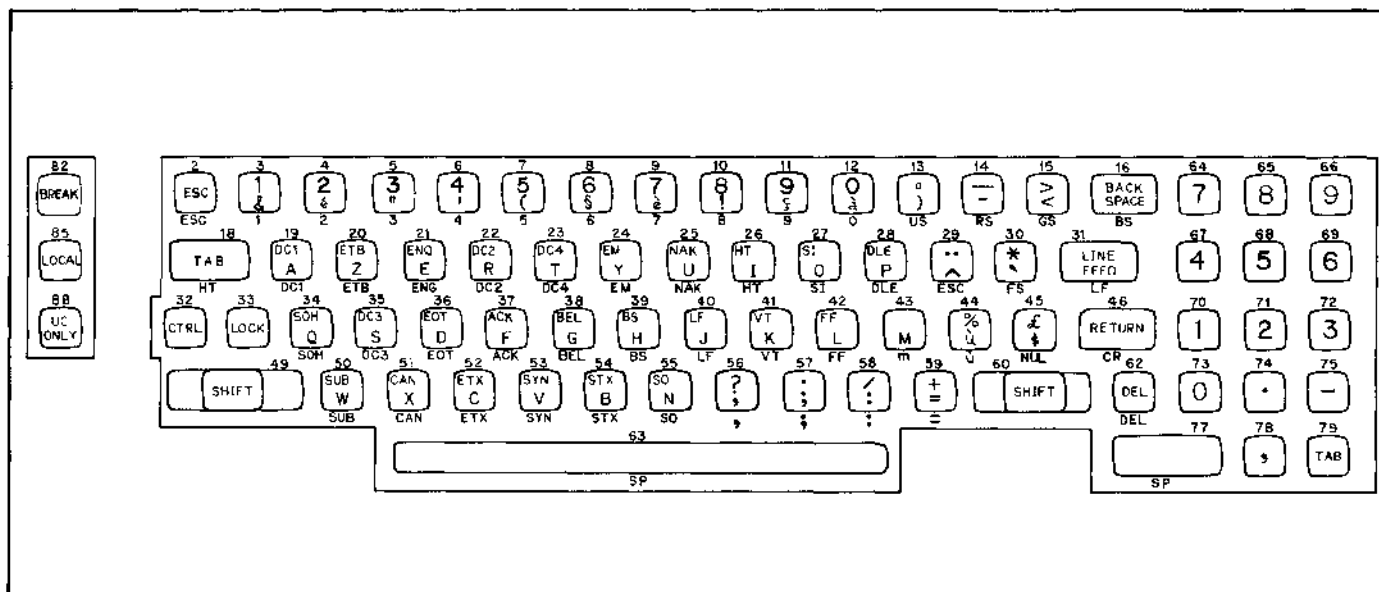

APPENDIX B (Continued)
KEYBOARD LAYOUTS AND CODE CHARTS

FRENCH AZERTY

| KEY POSITION | UNSHIFTED MODE | ASCII CODE (HEXADECIMAL) | SHIFTED MODE | ASCII CODE | CONTROL MODE | ASCII CODE |
|--------------|----------------|--------------------------|--------------|------------|--------------|------------|
| 1 | NUL | 00 | NUL | 00 | NUL | 00 |
| 2 | ESC | 1B | ESC | 1B | ESC | 1B |
| 3 | & | 26 | 1 | 31 | 1 | 31 |
| 4 | é | 7B | 2 | 32 | 2 | 32 |
| 5 | " | 22 | 3 | 33 | 3 | 33 |
| 6 | ' | 27 | 4 | 34 | 4 | 34 |
| 7 | (| 28 | 5 | 35 | 5 | 35 |
| 8 | § | 5D | 6 | 36 | 6 | 36 |
| 9 | è | 7D | 7 | 37 | 7 | 37 |
| 10 | ! | 21 | 8 | 38 | 8 | 38 |
| 11 | ç | 5C | 9 | 39 | 9 | 39 |
| 12 | à | 40 | 0 | 30 | 0 | 30 |
| 13 |) | 29 | ° | 58 | US | 1F |
| 14* | - | 2D | | 5F | RS | 1E |
| 15 | < | 3C | > | 3E | GS | 1D |
| 16* | BS | 08 | BS | 08 | BS | 08 |
| 17 | NUL | 00 | NUL | 00 | NUL | 00 |
| 18 | HT | 09 | HT | 09 | HT | 09 |
| 19 | a | 61 | A | 41 | DC1 | 11 |
| 20 | z | 7A | Z | 5A | ETB | 17 |
| 21 | e | 65 | E | 45 | ENQ | 05 |
| 22 | r | 72 | R | 52 | DC2 | 12 |
| 23 | t | 74 | T | 54 | DC4 | 14 |
| 24 | y | 79 | Y | 59 | EM | 19 |
| 25 | u | 75 | U | 55 | NAX | 15 |
| 26 | i | 69 | I | 49 | HT | 09 |
| 27 | o | 6F | O | 4F | SI | 0F |
| 28 | p | 70 | P | 50 | DLE | 10 |
| 29 | ^ | 5E | ~ | 7E | ESC | 1B |
| 30 | | 60 | * | 2A | FS | 1C |
| 31* | LF | 0A | LF | 0A | LF | 0A |
| 32 | CTRL | | | | | |
| 33 | LOCK | | | | | |
| 34 | q | 71 | Q | 51 | SOH | 01 |
| 35 | s | 73 | S | 53 | DC3 | 13 |
| 36 | d | 64 | D | 44 | EDT | 04 |
| 37 | f | 66 | F | 46 | ACK | 06 |
| 38 | g | 67 | G | 47 | BEL | 07 |
| 39 | h | 68 | H | 48 | BS | 08 |
| 40 | j | 6A | J | 4A | LF | 0A |
| 41 | k | 6B | K | 4B | VT | 0B |
| 42 | l | 6C | L | 4C | FF | 0C |
| 43 | m | 6D | M | 4D | m | 6D |
| 44 | ù | 7C | Z | 25 | ù | 7C |
| 45 | \$ | 24 | £ | 23 | NUL | 00 |
| 46* | CR | 0D | CR | 0D | CR | 0D |
| 47 | CTRL | | | | | |
| 48 | Function | | | | | |
| 49 | SHIFT | | | | | |
| 50 | w | 77 | W | 57 | SUB | 1A |
| 51 | x | 78 | X | 58 | CAN | 1B |
| 52 | c | 63 | C | 43 | ETX | 03 |
| 53 | v | 76 | V | 56 | SYN | 16 |
| 54 | b | 62 | B | 42 | STX | 02 |
| 55 | n | 6E | N | 4E | SO | 0E |
| 56 | , | 2C | ? | 3F | , | 2C |
| 57 | ; | 3B | . | 2E | ; | 3B |
| 58 | : | 3A | / | 2F | : | 3A |
| 59 | ' | 3D | + | 2B | ' | 3D |
| 60 | SHIFT | | | | | |
| 61 | NUL | 00 | NUL | 00 | NUL | 00 |
| 62 | DEL | 7F | DEL | 7F | DEL | 7F |
| 63* | SP | 20 | SP | 20 | SP | 20 |
| 64 | 7 | 37 | 7 | 37 | 7 | 37 |
| 65 | 8 | 38 | 8 | 38 | 8 | 38 |
| 66 | 9 | 39 | 9 | 39 | 9 | 39 |
| 67 | 4 | 34 | 4 | 34 | 4 | 34 |
| 68 | 5 | 35 | 5 | 35 | 5 | 35 |
| 69 | 6 | 36 | 6 | 36 | 6 | 36 |
| 70 | 1 | 31 | 1 | 31 | 1 | 31 |
| 71 | 2 | 32 | 2 | 32 | 2 | 32 |
| 72 | 3 | 33 | 3 | 33 | 3 | 33 |
| 73 | 0 | 30 | 0 | 30 | 0 | 30 |
| 74 | . | 2E | . | 2E | . | 2E |
| 75 | - | 2D | - | 2D | - | 2D |
| 76 | EOT | 04 | EOT | 04 | EOT | 04 |
| 77* | SP | 20 | SP | 20 | SP | 20 |
| 78 | , | 2C | , | 2C | , | 2C |
| 79 | HT | 09 | HT | 09 | HT | 09 |

*Denotes Repeat Keys

**APPENDIX B (Cont'd.)
KEYBOARD LAYOUTS AND CODE CHARTS**

GERMAN

Position Numbers above keytops refer to accompanying code chart table. Control codes and special symbols referenced below keytops identify "CTRL" mode output. These legends are not engraved on keytops.

100% compatible printwheels:

38132 German Pica 10

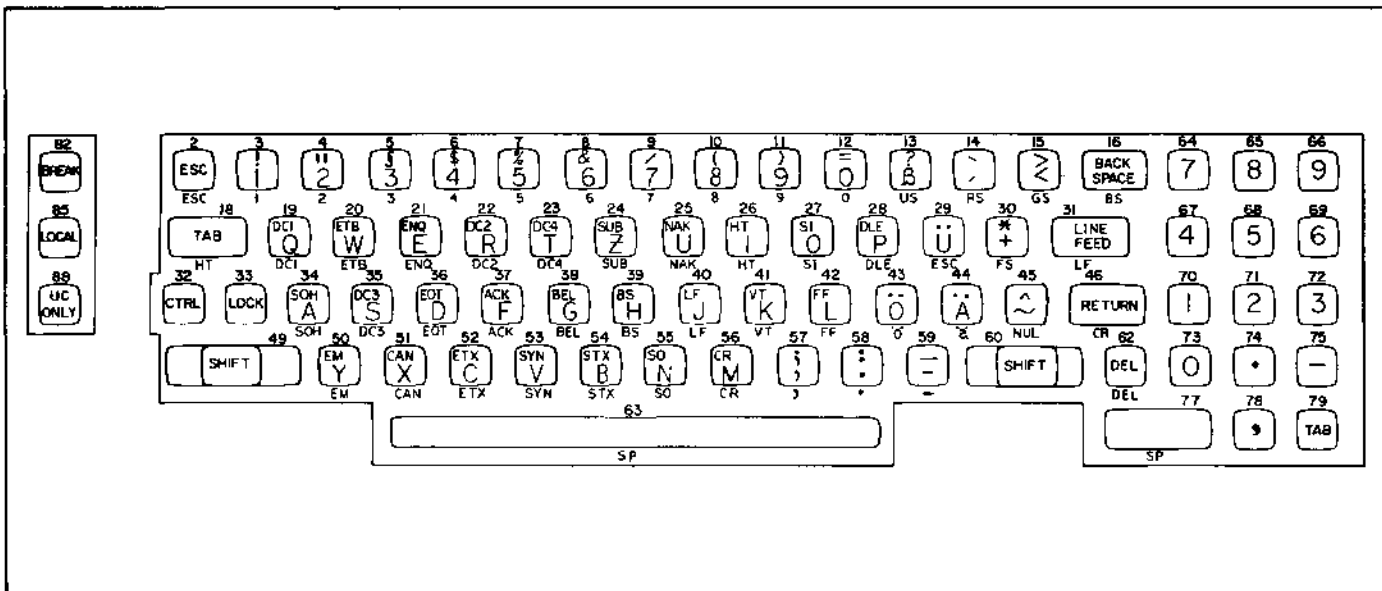

When UPPER CASE ONLY is used, lower case characters in positions 29, 43, and 44 are converted to upper case equivalents before being printed or transmitted.

**APPENDIX B (Continued)
KEYBOARD LAYOUTS AND CODE CHARTS**

GERMAN

| KEY POSITION | UNSHIFTED MODE | ASCII CODE (HEXADECIMAL) | SHIFTED MODE | ASCII CODE | CONTROL MODE | ASCII CODE |
|--------------|-----------------|--------------------------|--------------|------------|--------------|------------|
| 1 | NUL | 00 | NUL | 00 | NUL | 00 |
| 2 | ESC | 1B | ESC | 1B | ESC | 1B |
| 3 | ! | 31 | ! | 21 | 1 | 21 |
| 4 | " | 32 | " | 22 | 2 | 22 |
| 5 | # | 33 | # | 23 | 3 | 23 |
| 6 | \$ | 34 | \$ | 24 | 4 | 24 |
| 7 | % | 35 | % | 25 | 5 | 25 |
| 8 | & | 36 | & | 26 | 6 | 26 |
| 9 | / | 37 | / | 2F | 7 | 2F |
| 10 | (| 38 | (| 28 | 8 | 28 |
| 11 |) | 39 |) | 29 | 9 | 29 |
| 12* | = | 30 | = | 3D | 0 | 3D |
| 13* | ? | 40 | ? | 3F | US | 1F |
| 14 | ~ | 27 | ~ | 60 | RS | 1B |
| 15 | < | 3C | > | 3E | GS | 1D |
| 16* | BS | 08 | BS | 08 | BS | 08 |
| 17 | NUL | 00 | NUL | 00 | NUL | 00 |
| 18 | HT | 09 | HT | 09 | HT | 09 |
| 19 | q | 71 | Q | 51 | DC1 | 1F |
| 20 | w | // | W | 57 | ETB | 7E |
| 21 | e | 65 | E | 45 | ENQ | 0A |
| 22 | r | // | R | 52 | DC2 | 7F |
| 23 | t | 74 | T | 54 | DC4 | 7D |
| 24 | z | 7A | Z | 5A | SUB | 7C |
| 25 | u | 75 | U | 55 | NAK | 7B |
| 26 | i | 69 | I | 49 | HT | 09 |
| 27 | o | 6F | O | 4F | S1 | 0B |
| 28 | p | 70 | P | 50 | DLE | 7A |
| 29 | ü | 7B | Ü | 5B | ESC | 1B |
| 30 | + | 2B | = | 2A | FS | 7E |
| 31* | LF | 0A | LF | 0A | LF | 0A |
| 32 | CTRL. LOCK | | | | | |
| 33 | | | | | | |
| 34 | a | 61 | A | 41 | SOH | 01 |
| 35 | s | 73 | S | 53 | DC3 | 7D |
| 36 | d | 64 | D | 44 | EOT | 03 |
| 37 | f | 66 | F | 46 | ACK | 06 |
| 38 | g | 67 | G | 47 | BEL | 07 |
| 39 | h | 68 | H | 48 | BS | 08 |
| 40 | j | 6A | J | 4A | LF | 0A |
| 41 | k | 6B | K | 4B | VT | 0B |
| 42 | l | 6C | L | 4C | FF | 0C |
| 43 | ö | 7C | Ö | 5C | ö | 7C |
| 44 | ß | 7D | ß | 5D | ß | 7D |
| 45 | ' | 7E | ' | 5E | NUL | 00 |
| 46* | CR | 0D | CR | 0D | CR | 0D |
| 47 | CTRL. Funct ion | | | | | |
| 48 | SHIFT | | | | | |
| 49 | | | | | | |
| 50 | y | 79 | Y | 59 | EM | 7F |
| 51 | x | 78 | X | 58 | CAN | 78 |
| 52 | < | 63 | > | 43 | RTX | 79 |
| 53 | v | 76 | V | 56 | SYN | 76 |
| 54 | h | 62 | H | 42 | STX | 7E |
| 55 | n | 6F | N | 4E | SO | 7D |
| 56 | m | 6D | M | 4D | CR | 7C |
| 57 | v | 2C | ' | 3B | ' | 2C |
| 58* | - | 2E | ' | 3A | ' | 2E |
| 59 | - | 2D | ' | 5F | ' | 2D |
| 60 | SHIFT | | | | | |
| 61 | NUL | 00 | NUL | 00 | NUL | 00 |
| 62 | DEL | 7F | DEL | 7F | DEL | 7F |
| 63* | SP | 20 | SP | 20 | SP | 20 |
| 64 | 7 | 37 | 7 | 37 | 7 | 37 |
| 65 | 8 | 38 | 8 | 38 | 8 | 38 |
| 66 | 9 | 39 | 9 | 39 | 9 | 39 |
| 67 | 4 | 34 | 4 | 34 | 4 | 34 |
| 68 | 5 | 35 | 5 | 35 | 5 | 35 |
| 69 | 6 | 36 | 6 | 36 | 6 | 36 |
| 70 | 1 | 31 | 1 | 31 | 1 | 31 |
| 71 | 2 | 32 | 2 | 32 | 2 | 32 |
| 72 | 3 | 33 | 3 | 33 | 3 | 33 |
| 73 | 0 | 30 | 0 | 30 | 0 | 30 |
| 74 | . | 2E | . | 2E | . | 2E |
| 75 | - | 2D | - | 2D | - | 2D |
| 76 | HT | 09 | HT | 09 | HT | 09 |
| 77* | SP | 20 | SP | 20 | SP | 20 |
| 78 | ' | 2C | ' | 3C | ' | 2C |
| 79 | HT | 09 | HT | 09 | HT | 09 |

*Denotes Repeat Keys

**APPENDIX B (Cont'd.)
KEYBOARD LAYOUTS AND CODE CHARTS**

SCANDINAVIAN

Position Numbers above keytops refer to accompanying code chart table. Control codes and special symbols referenced below keytops identify "CTRL" mode output. These legends are not engraved on keytops.

100% compatible printwheels:

38133 Scandia Elite 12

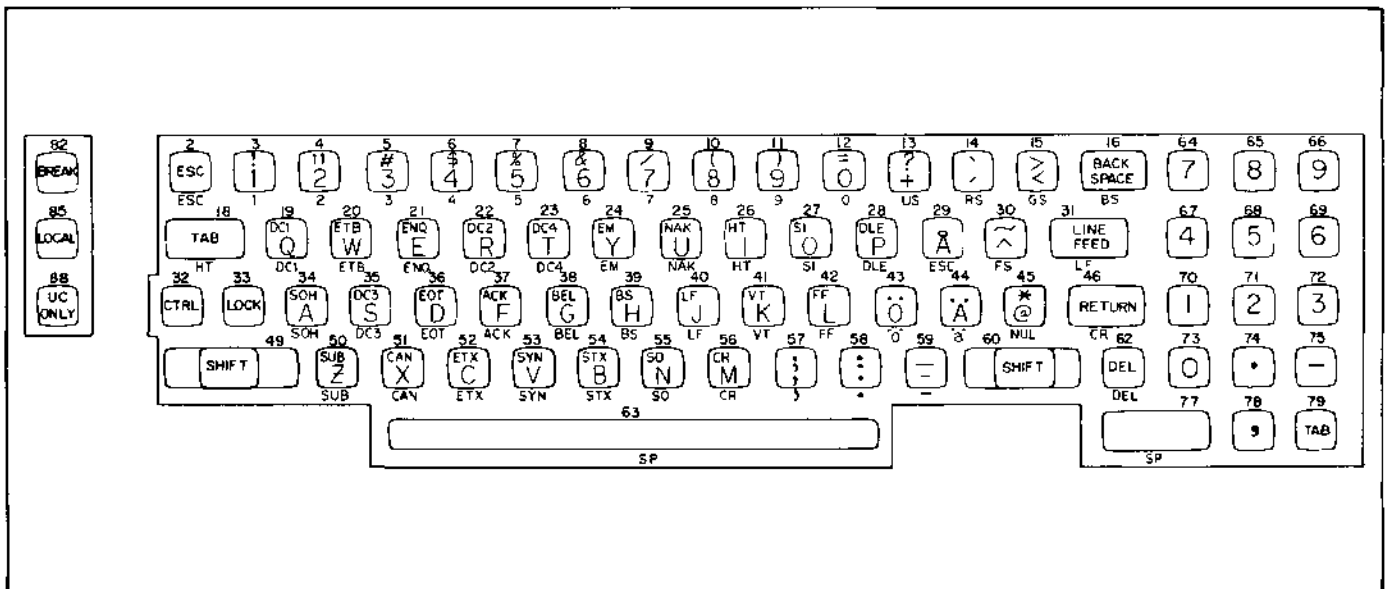

When UPPER CASE ONLY is used, lower case characters in positions 29, 43, and 44 are converted to upper case equivalents before being printed or transmitted.

APPENDIX B (Continued)
KEYBOARD LAYOUTS AND CODE CHARTS

SCANDINAVIAN

| KEY POSITION | UNSHIFTED MODE | ASCII CODE (HEXADECIMAL) | SHIFTED MODE | ASCII CODE | CONTROL MODE | ASCII CODE |
|--------------|----------------|--------------------------|--------------|------------|--------------|------------|
| 1 | NUL | 00 | NUL | 00 | NUL | 00 |
| 2 | ESC | 1B | ESC | 1B | ESC | 1B |
| 3 | 1 | 31 | ! | 21 | 1 | 31 |
| 4 | 2 | 32 | " | 22 | 2 | 32 |
| 5 | 3 | 33 | # | 23 | 3 | 33 |
| 6 | 4 | 34 | \$ | 24 | 4 | 34 |
| 7 | 5 | 35 | % | 25 | 5 | 35 |
| 8 | 6 | 36 | & | 26 | 6 | 36 |
| 9 | 7 | 37 | ' | 27 | 7 | 37 |
| 10 | 8 | 38 | (| 28 | 8 | 38 |
| 11 | 9 | 39 |) | 29 | 9 | 39 |
| 12* | 0 | 30 | = | 3D | 0 | 30 |
| 13* | + | 2B | ? | 3F | US | 1F |
| 14 | , | 27 | , | 6D | RS | 1E |
| 15 | < | 3C | > | 3E | GS | 1D |
| 16* | BS | 08 | BS | 08 | BS | 08 |
| 17 | NUL | 00 | NUL | 00 | NUL | 00 |
| 18 | HT | 09 | HT | 09 | HT | 09 |
| 19 | q | 71 | Q | 51 | DC1 | 11 |
| 20 | w | 77 | W | 57 | ETB | 17 |
| 21 | e | 65 | E | 45 | ENQ | 05 |
| 22 | r | 72 | R | 52 | DC2 | 12 |
| 23 | t | 74 | T | 54 | DC4 | 14 |
| 24 | y | 79 | Y | 59 | EM | 19 |
| 25 | u | 75 | U | 55 | NAK | 15 |
| 26 | i | 69 | I | 49 | HT | 09 |
| 27 | o | 6F | O | 4F | S1 | 0F |
| 28 | p | 70 | P | 50 | DLE | 10 |
| 29 | å | 7D | Å | 5D | ESC | 1B |
| 30 | . | 5E | . | 7E | FS | 1C |
| 31* | LF | 0A | LF | 0A | LF | 0A |
| 32 | CTRL | | | | | |
| 33 | LOCK | | | | | |
| 34 | a | 61 | A | 41 | SOH | 01 |
| 35 | s | 73 | S | 53 | DC3 | 13 |
| 36 | d | 64 | D | 44 | EOT | 04 |
| 37 | f | 66 | F | 46 | ACK | 06 |
| 38 | g | 67 | G | 47 | BEL | 07 |
| 39 | h | 68 | H | 48 | BS | 08 |
| 40 | j | 6A | J | 4A | LF | 0A |
| 41 | k | 6B | K | 4B | VT | 0B |
| 42 | l | 6C | L | 4C | FF | 0C |
| 43 | ö | 7C | Ö | 5C | ö | 7C |
| 44 | å | 7B | Å | 5B | å | 7B |
| 45 | @ | 40 | * | 2A | NUL | 00 |
| 46* | CR | 0D | CR | 0D | CR | 0D |
| 47 | CTR... | | | | | |
| 48 | Function | | | | | |
| 49 | SHIFT | | | | | |
| 50 | z | 7A | Z | 5A | SUB | 1A |
| 51 | x | 78 | X | 58 | CAN | 18 |
| 52 | c | 63 | C | 43 | ETX | 03 |
| 53 | v | 76 | V | 56 | SYN | 16 |
| 54 | b | 62 | B | 42 | STX | 02 |
| 55 | n | 6E | N | 4E | SO | 0E |
| 56 | m | 6D | M | 4D | CR | 0D |
| 57 | , | 2C | ; | 3B | , | 2C |
| 58* | - | 2E | : | 3A | - | 2E |
| 59 | - | 2D | - | 5F | - | 2D |
| 60 | SHIFT | | | | | |
| 61 | NUL | 00 | NUL | 00 | NUL | 00 |
| 62 | DEL | 7F | DEL | 7F | DEL | 7F |
| 63* | SP | 20 | SP | 20 | SP | 20 |
| 64 | 7 | 37 | 7 | 37 | 7 | 37 |
| 65 | 8 | 38 | 8 | 38 | 8 | 38 |
| 66 | 9 | 39 | 9 | 39 | 9 | 39 |
| 67 | 4 | 34 | 4 | 34 | 4 | 34 |
| 68 | 5 | 35 | 5 | 35 | 5 | 35 |
| 69 | 6 | 36 | 6 | 36 | 6 | 36 |
| 70 | 1 | 31 | 1 | 31 | 1 | 31 |
| 71 | 2 | 32 | 2 | 32 | 2 | 32 |
| 72 | 3 | 33 | 3 | 33 | 3 | 33 |
| 73 | 0 | 30 | 0 | 30 | 0 | 30 |
| 74 | . | 2E | . | 2E | . | 2E |
| 75 | - | 2D | - | 2D | - | 2D |
| 76 | EOT | 04 | EOT | 04 | EOT | 04 |
| 77* | SP | 20 | SP | 20 | SP | 20 |
| 78 | , | 2C | , | 2C | , | 2C |
| 79 | HT | 09 | HT | 09 | HT | 09 |

*Denotes Repeat Keys

**APPENDIX B (Cont'd.)
KEYBOARD LAYOUTS AND CODE CHARTS**

NORSK

Position Numbers above keytops refer to accompanying code chart table. Control codes and special symbols referenced below keytops identify "CTRL" mode output. These legends are not engraved on keytops.

100% compatible printwheels:

38148 Norsk Pica 10

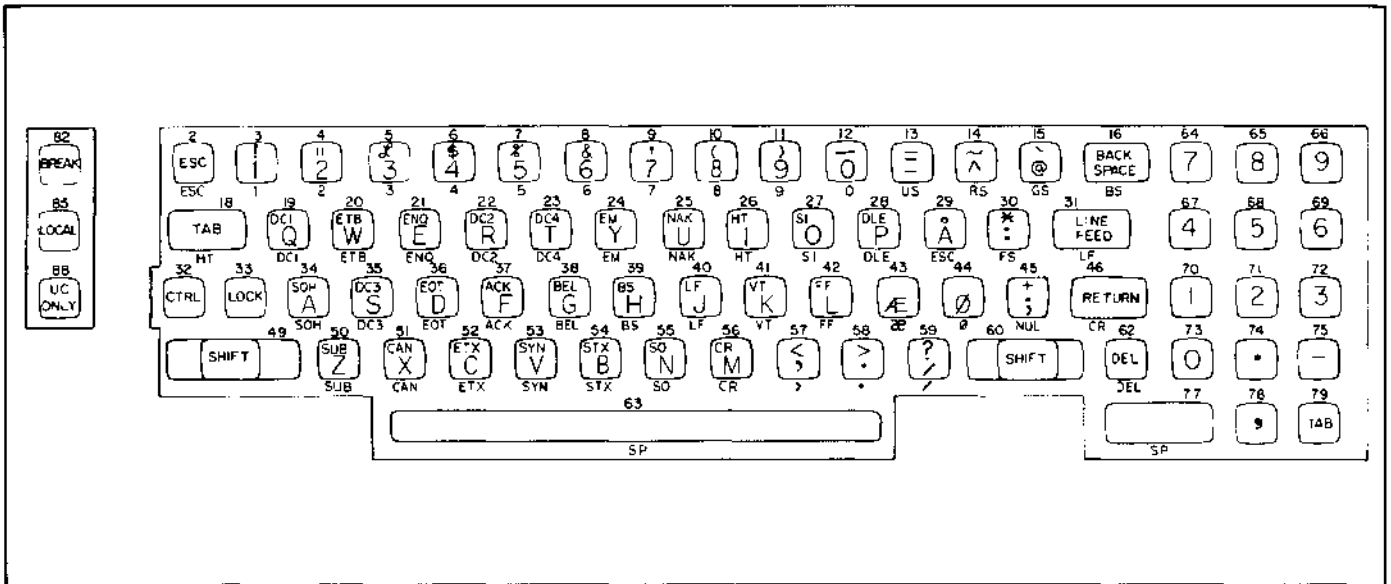

When UPPER CASE ONLY is used, lower case characters in positions 29, 43, and 44 are converted to upper case equivalents before being printed or transmitted.

**APPENDIX B (Continued)
KEYBOARD LAYOUTS AND CODE CHARTS**

NORSK

| KEY POSITION | UNSHIFTED MODE | ASCII CODE (HEXADECIMAL) | SHIFTED MODE | ASCII CODE | CONTROL MODE | ASCII CODE |
|--------------|----------------|--------------------------|--------------|------------|--------------|------------|
| 1 | NUL | 00 | NUL | 00 | NUL | 00 |
| 2 | ESC | 1B | ESC | 1B | ESC | 1B |
| 3 | ! | 31 | ! | 21 | 1 | 31 |
| 4 | " | 32 | " | 22 | 2 | 32 |
| 5 | £ | 33 | £ | 23 | 3 | 33 |
| 6 | \$ | 34 | \$ | 24 | 4 | 34 |
| 7 | % | 35 | % | 25 | 5 | 35 |
| 8 | & | 36 | & | 26 | 6 | 36 |
| 9 | ' | 37 | ' | 27 | 7 | 37 |
| 10 | (| 38 | (| 28 | 8 | 38 |
| 11 |) | 39 |) | 29 | 9 | 39 |
| 12* | 0 | 30 | _ | 5F | 0 | 30 |
| 13* | - | 2D | = | 3D | US | 1F |
| 14 | - | 5E | - | 7E | RS | 1E |
| 15 | @ | 40 | ` | 60 | GS | 1D |
| 16* | BS | 08 | BS | 08 | BS | 08 |
| 17 | NUL | 00 | NUL | 00 | NUL | 00 |
| 18 | HT | 09 | HT | 09 | HT | 09 |
| 19 | q | 71 | Q | 51 | DC1 | 11 |
| 20 | w | 77 | W | 57 | ETB | 17 |
| 21 | e | 65 | E | 45 | ENQ | 05 |
| 22 | r | 72 | R | 52 | DC2 | 12 |
| 23 | t | 74 | T | 54 | DC4 | 14 |
| 24 | y | 79 | Y | 59 | EM | 19 |
| 25 | u | 75 | U | 55 | NAK | 15 |
| 26 | i | 69 | I | 49 | HT | 09 |
| 27 | o | 6F | O | 4F | SI | 0F |
| 28 | p | 70 | P | 50 | DLE | 10 |
| 29 | å | 7D | Å | 5D | ESC | 1B |
| 30 | : | 3A | * | 2A | FS | 1C |
| 31* | LF | 0A | LF | 0A | LF | 0A |
| 32 | CTRL | | | | | |
| 33 | LOCK | | | | | |
| 34 | a | 61 | A | 41 | SOH | 01 |
| 35 | s | 73 | S | 53 | DC3 | 13 |
| 36 | d | 64 | D | 44 | EOT | 04 |
| 37 | f | 66 | F | 46 | ACK | 06 |
| 38 | g | 67 | G | 47 | BEL | 07 |
| 39 | h | 68 | H | 48 | BS | 08 |
| 40 | j | 6A | J | 4A | LF | 0A |
| 41 | k | 6B | K | 4B | VT | 0B |
| 42 | l | 6C | L | 4C | FF | 0C |
| 43 | æ | 7B | Æ | 5B | æ | 7B |
| 44 | ø | 7C | Ø | 5C | ø | 7C |
| 45 | ; | 3B | + | 2B | NUL | 00 |
| 46* | CR | 0D | CR | 0D | CR | 0D |
| 47 | CTRL | | | | | |
| 48 | Function | | | | | |
| 49 | SHIFT | | | | | |
| 50 | z | 7A | Z | 5A | SUB | 1A |
| 51 | x | 78 | X | 58 | CAN | 1B |
| 52 | c | 63 | C | 43 | ETX | 03 |
| 53 | v | 76 | V | 56 | SYN | 16 |
| 54 | b | 62 | B | 42 | STX | 02 |
| 55 | n | 6E | N | 4E | SO | 0E |
| 56 | m | 6D | M | 4D | CR | 0D |
| 57 | , | 2C | < | 3C | , | 2C |
| 58* | . | 2E | > | 3E | . | 2E |
| 59 | / | 2F | ? | 3F | / | 2F |
| 60 | SHIFT | | | | | |
| 61 | DEL | 7F | DEL | 7F | DEL | 7F |
| 62 | DEL | 7F | DEL | 7F | DEL | 7F |
| 63* | SP | 20 | SP | 20 | SP | 20 |
| 64 | 7 | 37 | 7 | 37 | 7 | 37 |
| 65 | 8 | 38 | 8 | 38 | 8 | 38 |
| 66 | 9 | 39 | 9 | 39 | 9 | 39 |
| 67 | 4 | 34 | 4 | 34 | 4 | 34 |
| 68 | 5 | 35 | 5 | 35 | 5 | 35 |
| 69 | 6 | 36 | 6 | 36 | 6 | 36 |
| 70 | 1 | 31 | 1 | 31 | 1 | 31 |
| 71 | 2 | 32 | 2 | 32 | 2 | 32 |
| 72 | 3 | 33 | 3 | 33 | 3 | 33 |
| 73 | 0 | 30 | 0 | 30 | 0 | 30 |
| 74 | . | 2E | . | 2E | . | 2E |
| 75 | - | 2D | - | 2D | - | 2D |
| 76 | EOT | 04 | EOT | 04 | EOT | 04 |
| 77* | SP | 20 | SP | 20 | SP | 20 |
| 78 | , | 2C | , | 2C | , | 2C |
| 79 | HT | 09 | HT | 09 | HT | 09 |

*Denotes Repeat Keys

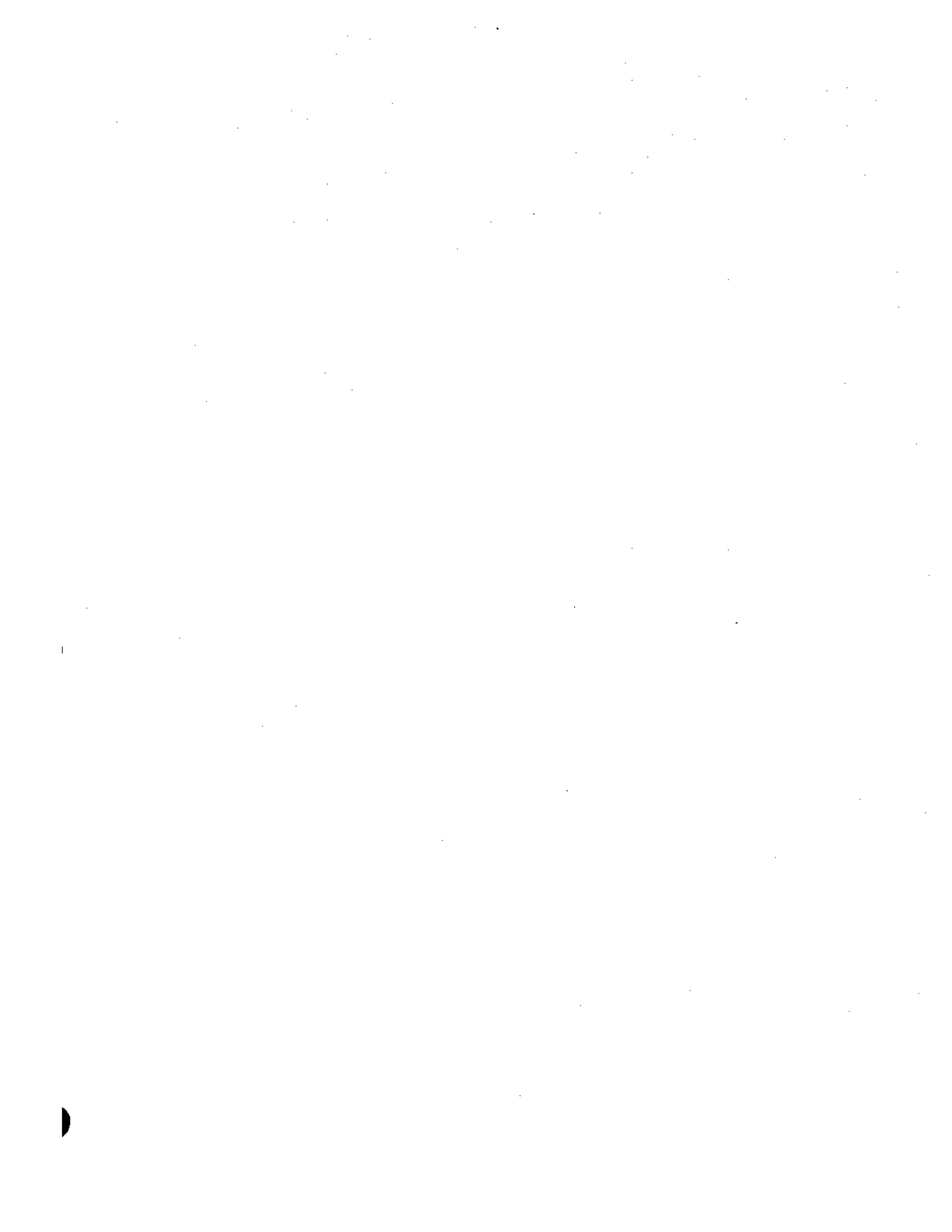

XEROX

Diablo Systems Incorporated

24500 Industrial Boulevard
Hayward, California 94545

A Xerox Company