

THE DIABLO HyType II 1355 WP

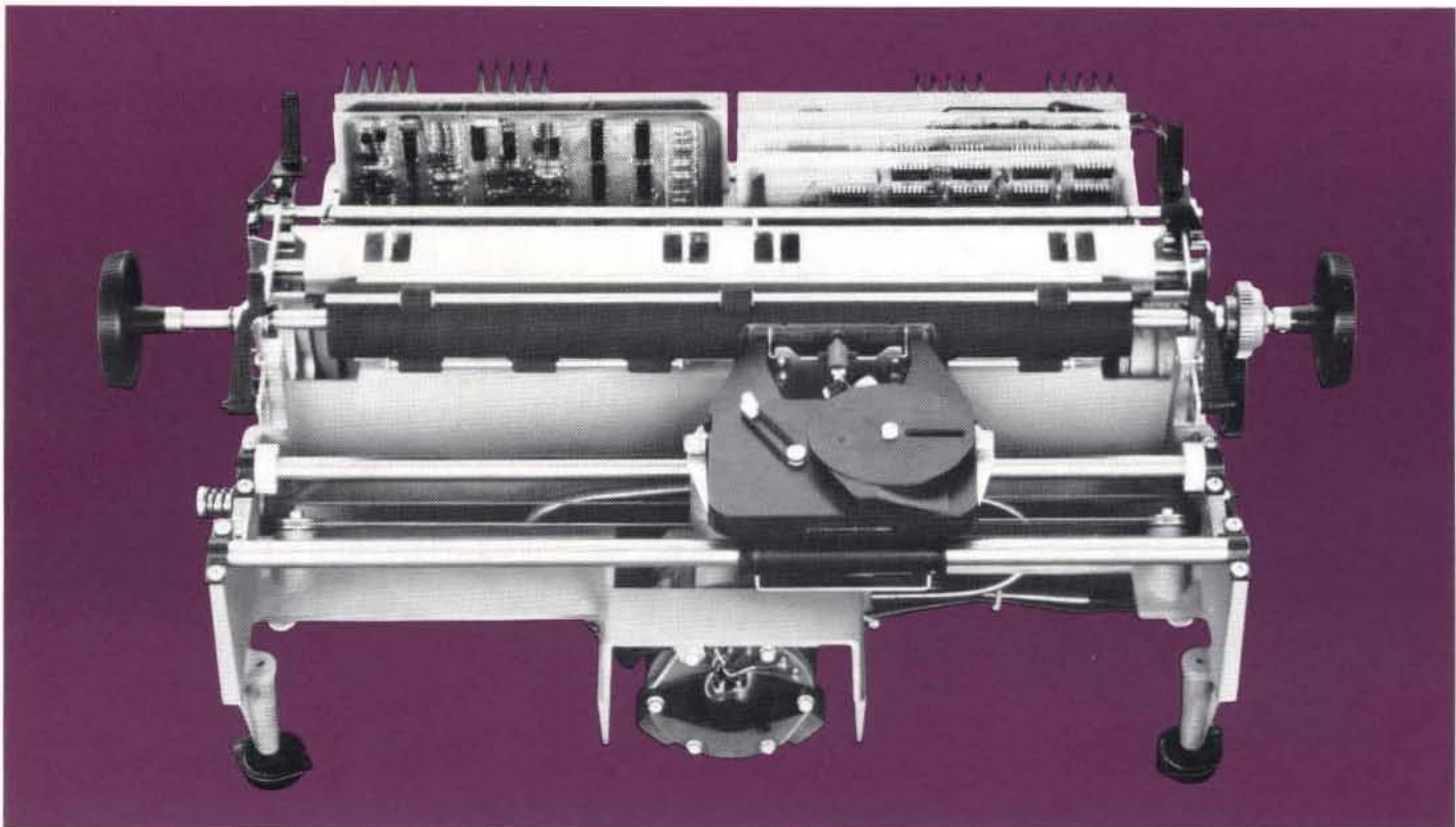

The Diablo HyType® II 1355 WP with the metal print wheel is designed specifically for OEM word processing applications.

Metal Print Wheel

Since its introduction, this composite metal-clad daisy wheel print element, and the HyType II 1355 WP printer designed to use it, have steadily gained acceptance among users of high quality serial printers. The metal-clad wheel was developed specifically in response to the need for very high quality printing and carbon sets (up to twelve copies depending on paper weight) by word processing users. Letter-quality printout is required to produce everything from legal forms to direct mail advertising literature and masters for offset printing.

Print Wheel Life

The metal-clad print wheels are also convenient in high volume printing operations because they do not have to be changed as often as plastic wheels. The plastic daisy wheel has an expected life of about 4 million characters. The metal-clad wheel, on the other hand, has an expected life of about 16 million characters; field experience indicates up to 30 to 50 million characters are possible.

Proportional Spaced Printing

True proportional spaced printing is available to the user software when using a metal-clad proportional space print wheel and controlling carriage advance

based on the proportional space unit value of the prior and current characters.

Character Density

Character density is the blackness of the printed characters, and is dependent upon the force with which the print hammer strikes the print element on the daisy wheel, and type of ribbon and paper used. The metal-clad print wheel is much more durable than plastic print wheels and can, therefore, withstand higher hammer impact in printers designed for word processing applications to produce a denser character impression.

Character Definition

Character definition is how well-formed characters appear to be printed, and is dependent on the design and molding of the print wheel element, and of the ability of the character to withstand wear during operation. Characters must not only be shaped for clear definition and be pleasing to the eye, but must also be engineered so that they resist wear and extend the life of the wheel. A too sharp edge on a particular character, for example, might wear faster than any other part of the character or character set and begin to produce blurred impressions. A rounded edge might produce less than adequate definition. To maintain this definition over an extended lifetime, metal-clad print wheel characters are molded in an extremely hard mono-plastic that encapsulates the ends of the metal spokes. The characters are then metal-plated for durability.

Diablo HyType II 1355 WP Printer Specifications

Print Speed: 40 characters per second.

Character Set: 88, 92 and 96 character print wheels.

Print Line: 132 columns (10 pitch).

Forms Width: 15 inches (381mm) maximum.

Carriage Return Time: 300 ms maximum for 132 columns.

Tabulation: Right and left, direct to column address.

Tabulation Speed: 300 ms maximum for 132 columns.

Column Spacing: 120 positions per inch nominal.

Paper Feed: Bi-directional.

Paper Feed Spacing: 48 positions per inch nominal.

Paper Feed Speed: 4 inches per second plus 50 ms settling delay.

Power Requirements

Voltages: +5 Vdc, 4 A; +15 Vdc, 9 A peak; -15 Vdc, 9 A peak.

Wattage: 100 W typical average.

Basic Configuration: The standard configuration includes mechanisms and circuitry to produce all print, control and status functions from a TTL or DTL compatible controller.

Physical Dimensions

Height: 8³/₄ inches.

Width: 23¹/₄ inches.

Depth: 13¹/₃ inches.

Weight: 27 pounds.

Environmental

Operating: 45°F to 105°F.

Storage: -20°F to 135°F.

Functional Elements Include:

Logic and microprocessor control circuits.

Print carriage positioning control and drive circuits.

Paper feed drive circuits.

Ribbon feed drive circuits.

Print wheel positioning control and drive circuits.

Hammer fire drive circuits.

Ribbon cartridge.

Optional Accessories:

Power supply.

Pin feed and split platens.

Operator interchangeable character wheel.

Auxiliary tractor form feed.

Multi-strike carbon ribbon cartridge.

Single-strike carbon ribbon cartridge.

Two-color ribbon cartridge.

Covers, typewriter or receive only.

Interface Options

Paper Out Status: Indicates that the paper out sensor has been activated.

End-of-Ribbon Status: Indicates that the end-of-ribbon sensor has been activated.

Covers Open Status: Indicates that the cover open sensor has been activated.

Direct Access To Hammer Energy: Allows user selection from eight hammer energy levels for special application.

Ribbon Advance I: Allows the user to force single step ribbon advance.

Ribbon Advance II: Allows the user to select, by interface control, either single or double step ribbon advance.

Direct Access To Print Wheel: Allows the user to have absolute addressing of the print wheel.

Diablo Systems Incorporated

24500 Industrial Boulevard

Hayward, California 94545

(415) 786-5000

Telex 336494

A Xerox Company

Western Region

2025 Gateway Place
Suite 220

San Jose, California 95110
408/286-9424

8939 S. Sepulveda Boulevard
Suite 103

Los Angeles, California 90045
213/641-0862

Central Region

South Barrington Road
Post Office Box 267

Barrington, Illinois 60010
312/381-3661

1215 Executive Drive East
Richardson, Texas 75081
214/234-0885

Eastern Region

1605 Trapelo Road
Waltham, Mass. 02154
617/890-6400

1145 Bordentown Avenue
Parlin, New Jersey 08859
201/727-2357

900 West State Highway 70
Marlton, New Jersey 08053
609/983-3353

International Offices

Diablo Systems GmbH
Riesenfeldstr. 75

8000 Munchen 40
West Germany

Telephone: 089/351 70 85-87

Telex: 841-5212088

Diablo Systems Ltd.

20 Broadway
Woking GU21 5AP

Surrey, England

Telex: 851/859148

Telephone: 048-62-71991

Diablo Systems SARL

28 Place Louvois

78140 Velizy, France

Telephone: (01) 946-23-35

Telex: 842-696925

Mitsui & Company, Ltd.

2-1 Ohtemachi, 1-Chome

Chiyoda-ku, Tokyo

Telephone: Tokyo: 03-285-1111

SERIES 1300

HyTYPE II PRINTERS

MAINTENANCE MANUAL

Models 1345A, 1355HS, 1355WP

82403-03 Rev D

July 1980

DIABLO SYSTEMS, INC.
A XEROX Company

FCC NOTICE

Warning: This equipment generates, uses and can radiate radio frequency energy and, if not installed and used in accordance with the instruction manual, may cause interference to radio communications. As temporarily permitted by regulation this equipment has not been tested for compliance with the limits for Class A computing devices pursuant to Subpart J of Part 15 of FCC Rules, which are designed to provide reasonable protection against such interference. Operation of this equipment in a residential area is likely to cause interference in which case the user, at his own expense, will be required to take whatever measures may be required to correct the interference.

WARRANTY

Diablo Series 1300 HyType II Printers are warranted against defects in materials and workmanship for 90 days from the date of shipment. Any questions with respect to the warranty should be directed to your Diablo Sales Representative.

UL recognized and listed under File No. E51242
CSA certified as a component under File No. LR2196

PREFACE

Diablo publishes descriptive Brochures and Data Sheets, a Product Description Manual, a Maintenance Manual, a Parts Catalog, and a Parts Price List for each product line. In addition, important changes to a product are conveyed to the field in the form of Field Service Aids sent to all product customers of record. Those changes which alter manual content are covered by publishing an Addenda to the affected manual.

Diablo Systems, Inc. reserves the right to make changes and/or improvements to its products without incurring any obligation to incorporate such changes or improvements in units previously sold or shipped.

Diablo publications may be requested from your Diablo Sales Representative, or may be ordered from Diablo in the same manner as spare parts.

Comments on all Diablo publications or their use are invited. Please use the Comment Form found at the back of this manual, or address your comments to:

Manager, Customer Service Publications
Diablo Systems, Inc.
3190 Corporate Place
Hayward, Ca. 94545

Diablo®, HyType®, and XEROX® are trademarks of Xerox Corporation
HyFeed is a trademark of Diablo Systems, Inc.

©Copyright 1979, 1980 by Diablo Systems, Inc., Hayward, Ca., USA

Publication No. 82403-03 - Fourth Edition

Previous Editions:

First - March 1976 (preliminary)
Second - August 1976
Third - July 1977

REVISION CONTROL RECORD

HyTYPE II SERIES MAINTENANCE MANUAL - PUBLICATION NO. 82403-03

NOTE: On revised pages of text, a heavy vertical bar in the margin indicates each area of new revision.

<u>PAGE/REV</u>	<u>PAGE/REV</u>	<u>PAGE/REV</u>	<u>PAGE/REV</u>	<u>PAGE/REV</u>	<u>PAGE/REV</u>		
Cover D	3-7 C	4-37 A	5-23 A	6-5 C			
i C	3-8 C	4-38 A	5-24 A				
ii A	3-9 C	4-39 A	5-25 A	7-1 A			
iii C	3-10 C	4-40 A	5-26 B	7-2 C			
iv C	3-11 C	4-41 C	5-27 B				
v C	3-12 A	4-42 C	5-28 C				
vi C	3-13 A	4-43 A	5-29 C				
vii C	3-14 A	4-44 A	5-30 C				
viii C		4-45 A	5-31 C				
ix C	4-1 A	4-46 C	5-32 C				
	4-2 A	4-47 C	5-33 C				
1-1 A	4-3 A	4-48 C	5-34 C				
1-2 A	4-4 A	4-49 C	5-35 A				
1-3 A	4-5 C	4-50 C	5-36 A				
1-4 A	4-6 A	4-51 A	5-37 A				
1-5 A	4-7 A	4-52 C	5-38 A				
1-6 A	4-8 A	4-53 A	5-39 A				
1-7 C	4-9 C	4-54 C	5-40 A				
1-8 A	4-10 C	4-55 C	5-42 A				
1-9 D	4-11 C	4-56 C	5-43 A				
	4-12 C	4-57 C	5-45 A				
2-1 A	4-13 C	4-58 A	5-46 A				
2-2 A	4-14 C		5-47 A				
2-3 A	4-15 A	5-1 A	5-48 A				
2-4 A	4-16 A	5-2 A	5-49 A				
2-5 C	4-17 A	5-3 C	5-50 A				
2-6 C	4-18 A	5-4 A	5-51 A				
2-7 A	4-19 A	5-5 A	5-52 A				
2-8 A	4-20 A	5-6 C	5-53 A				
2-9 C	4-21 A	5-7 A	5-54 A				
2-10 A	4-22 A	5-8 A	5-55 A				
2-11 A	4-23 A	5-9 A	5-56 A				
2-12 A	4-24 A	5-10 A	5-57 A				
2-13 A	4-25 C	5-11 A	5-58 A				
2-14 A	4-26 C	5-12 A	5-59 A				
2-15 A	4-27 C	5-13 A	5-60 A				
2-16 C	4-28 C	5-14 A	5-61 A				
2-17 A	4-29 C	5-15 A	5-62 A				
	4-30 A	5-16 A	5-63 A				
3-1 A	4-31 A	5-17 A	5-64 A				
3-2 A	4-32 A	5-18 A					
3-3 A	4-33 A	5-19 C	6-1 A				
3-4 A	4-34 A	5-20 A	6-2 A				
3-5 C	4-35 A	5-21 A	6-3 A				
3-6 C	4-36 A	5-22 A	6-4 A				

Schematics		REV
7-1a	40500-XX	F
7-1b	40614-04	H
7-1c	46080-01	C
7-2a	40505-09	B
7-2b	40644-05	B
7-2c	40725-05	A
7-3a	40510-XX	AJ
7-3b	301850-XX	C
7-4	40515-04	C
7-5a	40520-04	P
7-5b	46020-02	B
7-6a	40525-10	C
7-6b	46025-05	C
7-7a	40530-10	B
7-7b	40730-10	B
7-8a	24250-XX	C
7-8b	26021-XX	D
7-8c	301155-XX	C
7-9	40617-02	A
7-10	Miscellaneous	

TABLE OF CONTENTS

SECTION 1 - GENERAL DESCRIPTION AND SPECIFICATIONS

1.1	Introduction	1-1
1.2	General Specifications	1-2
1.2.1	Model 1345A	1-2
1.2.2	Model 1355HS	1-3
1.2.3	Model 1355WP	1-3
1.2.4	Print Wheels and Printing	1-4
1.2.5	Diablo Ribbon Cartridges and Ribbon Drive	1-4
1.2.6	Carriage Operation	1-4
1.2.7	Paper Feed	1-4
1.3	Performance Specifications	1-5
1.3.1	Print Speed	1-5
1.3.2	Character Set	1-5
1.3.3	Carriage Movement	1-5
1.3.4	Paper Handling	1-5
1.3.5	Power Requirements	1-6
1.3.6	Features	1-7
1.3.7	Environment	1-7
1.3.8	Ribbon Position Considerations	1-8
1.4	Print Speed Measurements	1-8
1.4.1	Performance Criteria	1-8
1.4.2	Performance Tests	1-8
1.4.2.1	The 3A Text	1-8
1.4.2.2	The Shannon Text	1-9
1.4.2.3	Print Speeds	1-9

SECTION 2 - INSTALLATION AND OPERATION

2.1	Installation	2-1
2.1.1	Space Requirements	2-1
2.1.2	Mounting	2-8
2.1.3	Power Supply Requirements	2-8
2.1.4	Grounding Requirements	2-9
2.1.5	Ventilation	2-10
2.1.6	Location	2-11
2.2	Interconnecting Cables	2-11
2.2.1	The Power Cable	2-11
2.2.2	The Input/Output (I/O) Interconnecting Cable	2-12
2.2.3	The Adapter Cable	2-13
2.3	Operation	2-16
2.3.1	General Information	2-16
2.3.2	Paper Loading	2-16
2.3.3	Paper Thickness Adjustment	2-16
2.3.4	Ribbon Cartridge Replacement	2-16
2.3.5	Print Wheel Replacement	2-17
2.3.6	Print Intensity Adjustment	2-17

SECTION 3 - INTERFACE INFORMATION

3.1	General Information	3-1
3.2	Input/Output Considerations	3-1
3.2.1	Signal Definitions	3-1
3.2.2	Input Lines	3-1
3.2.2.1	Select Printer Line	3-1
3.2.2.2	Strobe Lines	3-1
3.2.2.3	Restore Line	3-1

3.2.2.4	Ribbon Lift Line	3-1
3.2.2.5	Data Lines	3-1
3.2.3	Output Lines	3-10
3.2.3.1	Ready Lines	3-10
3.2.3.2	Check Line	3-11
3.2.3.3	Paper Out Line (Option)	3-11
3.2.3.4	Cover Open Line (Option)	3-11
3.2.3.5	End Of Ribbon Line (Option)	3-11
3.3	Timing Considerations	3-11
3.4	Input Gates	3-12
3.5	Drive Capability of Output Gates	3-13

SECTION 4 - PRINCIPLES OF OPERATION

4.1	General Discussion	4-1
4.2	Motherboard PCB Circuits	4-4
4.2.1	General Information	4-4
4.2.2	Standard Motherboard PCB, #40500-XX	4-5
4.2.3	8080 Interface Motherboard PCB, #40614-04	4-5
4.2.4	System Interface Motherboard PCB, #46080-01	4-5
4.3	Logic #1 PCB Circuits	4-6
4.3.1	General Information	4-6
4.3.1.1	Initialization and Start-Up	4-7
4.3.1.2	Command Entry	4-8
4.3.1.3	Operating Control Logic	4-8
4.3.2	Logic #1 PCB Assy, Std., #40505-09	4-9
4.3.2.1	Initialization and Start-Up	4-9
4.3.2.2	Command Entry	4-10
4.3.2.3	Operating Control Logic	4-11
4.3.3	Logic #1 PCB Assy, 8080, #40644-05	4-15
4.3.3.1	Initialization and Start-Up	4-15
4.3.3.2	Command Entry	4-15
4.3.3.3	Operating Control Logic	4-17
4.3.4	Logic #1 PCB Assy, Spec. D, #40725-05	4-19
4.3.4.1	Initialization and Start-Up	4-19
4.3.4.2	Command Entry	4-20
4.3.4.3	Operating Control Logic	4-21
4.4	Logic #2 PCB Circuits	4-25
4.4.1	General Information	4-25
4.4.2	Logic #2 PCB Assy, Std, #40510-XX	4-25
4.4.2.1	Initialization and Start-Up	4-25
4.4.2.2	Program Control Loop A	4-26
4.4.2.3	Data Processing Loop B	4-26
4.4.2.4	Data Output Loop C	4-26
4.4.2.5	Model Variations	4-27
4.4.3	Logic #2 PCB Assy, Std ESD, #301850-XX	4-27
4.4.3.1	Initialization and Start-Up	4-27
4.4.3.2	Program Control Loop A	4-27
4.4.3.3	Data Processing Loop B	4-27
4.4.3.4	Data Output Loop C	4-28
4.4.3.5	Model Variations	4-28
4.5	Transducer PCB Assy, Std., #40515-04	4-28
4.5.1	General Information	4-28
4.5.2	The Sine-wave Drive Generator	4-28
4.5.3	Servo Position Transducer	4-29
4.5.4	Servo Feedback Amplifier	4-31

4.6	Servo PCB Circuits	4-35
4.6.1	General Information	4-35
4.6.2	Servo PCB Assy, Std., #40520-04	4-36
4.6.2.1	The D-A Converter	4-36
4.6.2.2	The Sample and Hold Circuit	4-36
4.6.2.3	Servo Direction Switching	4-37
4.6.2.4	Servo Tachometer Circuits	4-38
4.6.2.5	Servo Summation Amplifier	4-40
4.6.3	Servo PCB Assy, 1355HS, #46020-02	4-40
4.7	Carriage Power Amplifier PCB Circuits	4-40
4.7.1	General Information	4-40
4.7.2	Carriage Power Amplifier PCB Assy, Std., #40525-08	4-41
4.7.2.1	Carriage Power Amplifier Circuit	4-41
4.7.2.2	Power Monitor Circuit	4-42
4.7.2.3	Paper Feed Drive Circuit	4-45
4.7.3	Carriage Power Amplifier PCB Assy, ESD, #40525-11	4-46
4.7.4	Carriage Power Amplifier PCB Assy, 1355HS, #46025-05	4-46
4.7.5	Carriage Power Amplifier PCB Assy, 1355HS ESD, #46025-06	4-46
4.8	Print Wheel Power Amplifier PCB Circuits	4-46
4.8.1	General Information	4-46
4.8.2	Print Wheel Power Amplifier PCB Assy, Std., #40530-10	4-46
4.8.2.1	Print Wheel Power Amplifier Circuit	4-46
4.8.2.2	Ribbon Lift Drive Circuit	4-48
4.8.2.3	Ribbon Feed Drive Circuit	4-48
4.8.2.4	Hammer Energy Control and Drive Circuit	4-48
4.8.3	Print Wheel Power Amplifier PCB Assy, ESD, #40530-11	4-49
4.8.4	Print Wheel Power Amplifier PCB Assy, 1355 Std, #40730-10	4-49
4.8.5	Print Wheel Power Amplifier PCB Assy, 1355 ESD, #40730-11	4-49
4.9	Internal Power Supply Options	4-50
4.9.1	General Information	4-50
4.9.2	Internal Power Supply Assy, DP, #24250-XX	4-50
4.9.3	Internal Power Supply Assy, B, #26021-XX	4-52
4.9.3.1	General Information	4-52
4.9.3.2	Input Surge Limit and Filter Circuits	4-52
4.9.3.3	Full Wave Bridge Rectifier and Local +15 Volt Supply	4-53
4.9.3.4	Power Switch and Switching Regulator Amplifier	4-53
4.9.3.5	LC Smoothing Filter and Spike Catcher	4-53
4.9.3.6	The Inverter	4-54
4.9.3.7	DC Output Circuits	4-54
4.9.3.8	+5 Volt Error Amplifier	4-54
4.9.3.9	Current Limiting and Overvoltage Protection	4-54
4.9.4	Internal Power Supply Assy, U, #301155-XX	4-55
4.9.4.1	General Information	4-56
4.9.4.2	Input Surge Limit and Filter Circuit	4-56
4.9.4.3	Full Wave Bridge Rectifier and Local +20 Volt Supply	4-56

4.9.4.4	Power Switch and Switching Regulator Amplifiers	4-56
4.9.4.5	LC Smoothing Filter and Spike Catcher	4-57
4.9.4.6	The Inverter	4-57
4.9.4.7	DC Output Circuits	4-57
4.10	Split Platen Option	4-57

SECTION 5 - MAINTENANCE

5.1	General Discussion	5-1
5.1.1	Maintenance Requirements	5-1
5.1.2	Maintenance Instructions	5-1
5.1.3	Maintenance Precautions	5-1
5.2	Maintenance Levels, Tools, Equipment and Spares	5-2
5.2.1	Levels of Maintenance	5-2
5.2.1.1	Level 1	5-2
5.2.1.2	Level 2	5-2
5.2.1.3	Level 3	5-2
5.2.2	Preventive Maintenance Items - Level 1	5-2
5.2.3	Corrective Maintenance Items - Levels 1 and 2	5-3
5.2.4	Corrective Maintenance Items - Levels 1, 2 and 3	5-3
5.3	Preventive Maintenance - Maintenance Level 1	5-3
5.3.1	Preventive Maintenance Philosophy	5-3
5.3.2	Preventive Maintenance Procedures	5-4
5.3.3	Cleaning and Inspection	5-4
5.3.4	Lubrication	5-4
5.3.4.1	Carriage System	5-4
5.3.4.2	Carrier System	5-6
5.3.4.3	Platen System	5-6
5.3.4.4	Lubrication of Optional Items	5-7
5.4	Corrective Maintenance - Maintenance Level 2	5-7
5.4.1	Corrective Maintenance Philosophy	5-7
5.4.2	HyType II Service Tests	5-7
5.4.2.1	Trouble Shooting The HyType II Printer	5-7
5.4.2.2	Print Quality	5-12
5.4.2.3	Print Quality Adjustments	5-12
5.4.2.4	Conditions of Test and Alignment	5-13
5.4.3	Paper Carrier System - Replacement and/or Adjustment Procedures	5-14
5.4.3.1	Paper Carrier Subassembly Removal	5-14
5.4.3.2	Paper Feed Motor Removal and Replacement	5-15
5.4.3.3	Paper Carrier Subassembly Installation Procedure	5-17
5.4.3.4	Paper Carrier System Adjustments	5-18
5.4.4	Carriage Systems - Replacement and/or Adjustment Procedure	5-20
5.4.4.1	Carriage Subassembly Removal	5-20
5.4.4.2	Carriage Subassembly Replacement	5-23
5.4.4.3	Paper Carrier System to Carriage System Adjustments	5-26
5.4.4.4	Carriage Home Adjustment	5-32
5.4.4.5	Print Wheel To Hammer Alignment	5-33
5.4.4.6	Print Wheel Home Adjustment	5-35
5.4.4.7	Hammer Adjustment	5-36
5.4.5	Carriage Drive System	5-38
5.4.5.1	Carriage Drive Cable Removal	5-38
5.4.5.2	Carriage Servo Motor Replacement	5-39

5.4.5.3	Carriage Drive Cable Replacement	5-40
5.4.5.4	Carriage Drive Cable Adjustment	5-42
5.4.6	Motherboard Replacement	5-43
5.4.7	Bottom Feed Paper Chute Option - Assembly, Installation and Adjustment	5-44
5.4.7.1	Assembly Procedures	5-44
5.4.7.2	Installation Procedures	5-46
5.4.7.3	Adjustment Procedures	5-47
5.4.8	#24460 Top Paper Out Switch Option	5-49
5.4.8.1	Switch Mounting - Bracket Installation	5-49
5.4.8.2	Alternate Switch Mounting - Nut Plate Installation	5-50
5.4.8.3	Top Paper Out Switch Bail Installation	5-51
5.4.8.4	Top Paper Out Switch Adjustment	5-52
5.4.9	#40504-XX Cover Open Switch Option - Installation and Adjustment	5-52
5.4.9.1	Front Mounted Switch Installation Procedure	5-53
5.4.9.2	Front Mounted Switch Actuator Installation Procedure	5-54
5.4.9.3	Front Mounted Switch and Actuator Adjustment Procedure	5-54
5.4.9.4	Side Mounted Switch Adjustment Procedure	5-55
5.4.10	Adapter Cable Option Installation	5-55
5.4.11	Split Platen Option-Installation and Adjustment	5-56
5.4.12	End Of Ribbon Sensor Option-Installation	5-56
5.4.13	Internal Power Supply Options	5-57
5.4.13.1	Installation of the #24250-XX Power Supply (Datapower)	5-57
5.4.13.2	Installation of the #26021-XX Power Supply (Boschert)	5-60
5.4.13.3	Installation of the #301155-XX Diablo Universal Internal Power Supply	5-63
5.4.13.4	Installation of the #40809-XX Cooling Fan	5-63

SECTION 6 - APPENDICES

6.1	General Information	6-1
6.2	The Standard HyType II Printer	6-1
6.3	Supplies	6-1
6.4	Accessories	6-1
6.4.1	Cover Sets	6-1
6.4.2	Paper Handling Accessories	6-1
6.4.2.1	Platens	6-1
6.4.2.2	Forms Tractors	6-2
6.4.2.3	Bottom Feed	6-2
6.4.2.4	Sheet Feeders	6-2
6.5	Options	6-3
6.5.1	Jumper Wire Operating Mode Options	6-3
6.5.2	Split Platen Drive	6-3
6.5.3	HyType I Adapter Cable	6-4
6.5.4	Paper Out Circuit and Switches	6-4
6.5.4.1	Paper Out Circuit	6-4
6.5.4.2	Bottom Feed Paper Out Switch	6-4
6.5.4.3	Top Feed Paper Out Switch	6-4
6.5.5	End Of Ribbon Circuit and Sensor	6-4
6.5.5.1	End Of Ribbon Circuit	6-4
6.5.5.2	End Of Ribbon Sensor	6-5

6.5.6	Cover Open Circuit and Switch	6-5
6.5.6.1	Cover Open Circuit	6-5
6.5.6.2	Cover Open Switch	6-5
6.5.7	Internal Power Supply	6-5

SECTION 7 - LOGIC DIAGRAMS AND LOGIC SYMBOL CONVENTIONS

7.1	General Discussion	7-1
7.1	Logic Symbology	7-1
7.3	Logic Devices	7-2
7.4	Schematic Diagrams	7-2

LIST OF ILLUSTRATIONS

<u>Figure</u>		<u>Page</u>
1-1	Series 1300 HyType II Printer	1-1
1-2	Typical Print Wheels	1-3
1-3	Print Wheel Shields	1-3
1-4	Ribbon Cartridges	1-3
2-1A	HyType II External Dimensions	2-1
2-1B	HyType II External Dimensions	2-2
2-2	Diablo Unidirectional Forms Tractor	2-3
2-3	Diablo Bidirectional Forms Tractor	2-4
2-4	Auto Front Feed and Bidirectional Forms Tractor	2-5
2-5	Mechanical Front Feed	2-6
2-6	HyFeed Sheet Feeder	2-7
2-7	The Diablo Model 215 Power Supply	2-8
2-8	Typical Internal Power Supply	2-8
2-9	Noise Immunity Grounding	2-10
2-10	Power Connector Pin Arrangement	2-11
2-11	I/O Connector Wire Side Pin Arrangement	2-12
2-12	HyType II to HyType I Adapter Cable	2-13
2-13	HyType II to HyType I Adapter Cable Mating Plug Pin Assignment	2-14
2-14	HyType II Features	2-15
3-1	96 Character Plastic Print Wheel Physical Spoke Position	3-5
3-2	Xerox 88 Character Metalized Word Processor Print Wheel	3-6
3-3	Typical Command Sequence	3-12
3-4	Standard Input Circuits	3-13
3-5	Output Driver Circuit	3-14
4-1	HyType II Printer Block Diagram	4-1
4-2	Component Locations	4-3
4-3	Logic #1 Block Diagram	4-7
4-4	Typical Command Sequence	4-7
4-5	Carriage Difference Counter Decrement Drive	4-13
4-6	8080 Logic #1 Block Diagram	4-16
4-7	Logic #2 Block Diagram	4-25
4-8	Sinewave Drive Generator Waveforms	4-30
4-9	Servo Position Transducer	4-31
4-10	Servo Feedback Amplifier	4-31
4-11	Servo Feedback Amplifier Waveforms	4-32
4-12	Servo Feedback Demodulator/Integrator/Amplifier	4-33
4-13	Servo Feedback Demodulator/Integrator/Amplifier Waveforms	4-33
4-14	Waveform Analysis	4-33
4-15	Servo PCB Block Diagram	4-35
4-16	D-A Converter Circuit	4-36

4-17	Typical Sample and Hold Circuit	4-37
4-18	Carriage Position Tachometer Circuit	4-38
4-19	CAR POS Tachometer Waveforms	4-39
4-20	CAR POS FET Input Waveforms	4-39
4-21	Carriage Power Amplifier Simplified Diagram	4-41
4-22	Feedback Instrumentation Circuit	4-42
4-23	Power Monitor Circuit Block Diagram	4-42
4-24	Power Monitor Circuit	4-43
4-25	Paper Feed Drive Circuit	4-44
4-26	Paper Drive Waveforms	4-44
4-27	Typical Stepper Motor Rotation	4-45
4-28	Print Wheel Feedback Instrumentation Circuit	4-47
4-29	Hammer Energy Control Circuit	4-49
4-30	Optional Internal Power Supply Block Diagram (DP)	4-50
4-31	Optional Internal Power Supply Block Diagram (B)	4-52
4-32	Optional Internal Power Supply Block Diagram (U)	4-55
5-1	Carriage System Lubrication Points	5-5
5-2	Carriage System Lubrication Points	5-5
5-3	Carrier System Lubrication Points	5-6
5-4	Platen System Lubrication Points	5-7
5-5	Adjustment Tools	5-13
5-6	Carrier Systems Removal - A	5-14
5-7	Carrier Systems Removal - B	5-15
5-8	Carrier Systems Removal - C	5-15
5-9	Paper Feed Motor Removal	5-16
5-10	Carrier Systems Replacement	5-17
5-11	Carrier Assembly Adjustments	5-18
5-12	Paper Feed Adjustments	5-19
5-13	Paper Feed Drive Adjustments	5-20
5-14	Platen Knob End Play Adjustment	5-20
5-15	Prepare Carriage Cables for Removal	5-21
5-16	Cable Clamp Removal	5-21
5-17	Disconnecting The Carriage Drive Cable	5-22
5-18	Carriage Rail Clamps	5-23
5-19	Carriage and Rail Reassembly	5-24
5-20	Platen To Print Wheel Adjustment Points	5-26
5-21	Platen Position Eccentrics Adjustment Limits	5-27
5-22	Card Guide Adjustments	5-28
5-23	Ribbon Height Adjustment	5-29
5-24	Card Guide Alignment	5-30
5-25	Platen Height Eccentrics	5-31
5-26	Platen Height Eccentrics Adjustment Limits	5-31
5-27	Carriage Home Adjustment	5-32
5-28	Print Wheel To Hammer Alignment	5-33
5-29	Print Wheel "Home" Alignment	5-35
5-30	Print Wheel Home Sensor Waveform	5-36
5-31	Hammer Adjustments	5-37
5-32	Hammer Adjustment Tool #40796 and Shim	5-37
5-33	Drive Cable Tension Spring	5-39
5-34	Carriage Servo Motor Mounting Screws	5-39
5-35	Carriage Cable Drive System Schematic	5-40
5-36	Right-Hand Carriage Drive Cable Installation	5-41
5-37	Carriage Drive Cable Tension Spring Assembly	5-42
5-38	Carriage Drive Cable Adjustment	5-43
5-39	Bottom Feed Paper Chute Assembly Parts	5-44
5-40	Bail and Front Chute Assembly	5-45

5-41	Rear To Front Chute Assembly	5-45
5-42	Upper Paper Chute Mounting Bracket Installation	5-46
5-43	Bottom Feed Paper Chute Paper Out Switch Parts	5-47
5-44	Bottom Feed Paper Chute Adjustments	5-48
5-45	Top Feed Paper Out Switch Assembly Parts	5-49
5-46	Top Paper Out Switch and Bail Installation	5-50
5-47	Top Paper Out Switch and Bail Installation Locations	5-50
5-48	Top Paper Out Switch Disable Assembly	5-51
5-49	Cover Open Switch Assembly Parts	5-53
5-50	Front Cover Open Switch Installation	5-53
5-51	Front Cover Open Switch Actuator Installation	5-54
5-52	Side Cover Open Switch Installation	5-55
5-53	Adapter Cable Option Installation	5-55
5-54	Internal Power Supply #24250-XX Installation Parts	5-57
5-55	Fan Air Deflector Installation	5-58
5-56	Screen and Shield Installation	5-58
5-57	AC Cable and Fan Installation	5-60
5-58	Internal Power Supply #26021-XX Installation Parts	5-61
5-59	AC and DC Power Connections	5-61
5-60	AC and DC Cable Installation	5-62
5-61	Cooling Fan Installation Parts	5-63
5-62	Cooling Fan Assembly Installation	5-63

LIST OF TABLES

<u>Table</u>		<u>Page</u>
2-1	Power Cable Pin Assignments	2-11
2-2	I/O Cable Wire Dedication	2-12
3-1	Data Line Significance During Various Strobe Commands	3-2
3-2	Option Jumper Significance	3-2
3-3	Print Wheel Data	3-4
3-4	Hammer Energy Option Command Data	3-5
3-5	Word Processor Print Wheel Data (88- & 92-Character)	3-8
3-6	Word Processor Print Wheel Data (96-Character)	3-9
3-7	Character Proportional Space Units - WP Carriage Advance	3-10
3-8	Proportional Space Units Carriage Advance	3-11
3-9	Proportional Space Units Ribbon Advance	3-11
4-1	Standard Motherboard Connectors and Assignments	4-4
4-2	8080 Motherboard Connectors and Assignments	4-4
4-3	Systems Motherboard Connectors and Assignments	4-6
4-4	HyType II Logic #2 Processor PCB PROM Chart	4-29
5-1	Platen To Print Wheel Clearances	5-27

SECTION 1

GENERAL DESCRIPTION AND SPECIFICATIONS

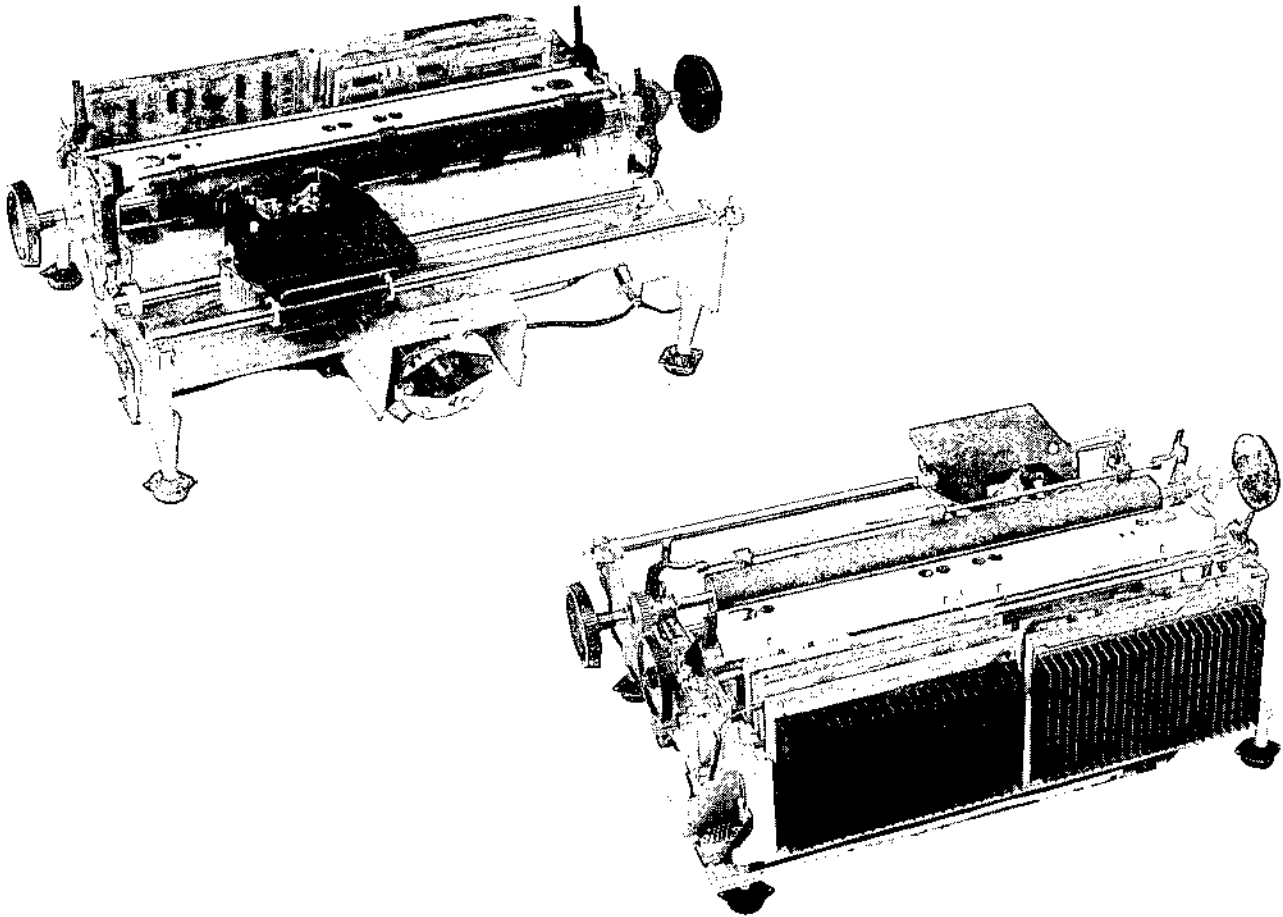

Figure 1-1. SERIES 1300 HYTYPE II PRINTER

1.1 INTRODUCTION

The Diablo Series 1300 HyType II Serial Printer is a reliable compact unit. It is designed for use in any application requiring a medium speed device with multiple forms capability and high print quality.

The field proven electronic control techniques found in the HyType II eliminate most of the moving parts found in conventional printers. These techniques are noted for their inherent accuracy, reliability, and freedom from wear. They assure the continuous output of top quality printing required in computer based systems.

The HyType II maintains physical and basic electrical compatibility with the earlier HyType I format, while offering improvements and additional features. These are:

- # Microprocessor based control logic for increased capacity and flexibility, plus provision for implementation of additional features.
- # Advanced servo design for improved efficiency and performance.
- # Rigid one piece cast aluminum frame to better maintain print quality, and reduce maintenance requirements.
- # Rugged highly stable carriage assembly for enhanced print position accuracy and reduced maintenance.
- # Plug-in interchangeable printed circuit boards (PCB's), readily accessible for ease and simplicity of service, and implementation of options and interfaces.
- # Operator control of print hammer energy (Impression Control Switch) to shift the printer's internal hammer energy scale up for multiple carbon forms or down for smaller lighter print font styles.
- # 1/120 inch (.212 mm) horizontal spacing on command.
- # Optional interface access to directly address print hammer energy levels character by character.
- # Optional interface access to command ribbon advance.
- # Optional Paper Out Switch installation for either normal top or an optional bottom paper feed.
- # Optional Cover Open Switch installation.
- # Optional End Of Ribbon sensor installation for use with multi-strike carbon ribbon cartridges which are not the recirculating type.
- # Optional Internal Power Supply. **
- # Optional Split Platen Drive installation. **

** = Installation of either of these options precludes installation of the other.

Note that certain of these features would require HyType I interface alterations to be implemented.

1.2 GENERAL SPECIFICATIONS

The Diablo Series 1300 HyType II Serial Printer family consists of several distinct models. The following subsections outline the general specifications as they apply to each model.

1.2.1 Model 1345A

This is the standard or basic model of the HyType II family. It uses Diablo's familiar 96 character plastic daisy print wheel in both 10 and 12 pitch, and accepts character commands in the form of a Diablo modified ASCII code. It is capable of print speeds up to 45 characters per second in the 12 pitch mode. Several operating options are offered with this model, as mentioned above. These are discussed in subsection 3.2.2.5.1. They are implemented by jumper wires installed at the factory, or inserted later by your Service Technician.

1.2.2 Model 1355HS

This model is capable of print speeds up to 55 characters per second in the 12 pitch mode. Some of the operating options offered with the Model 1345A are also available with this model. They are discussed in subsection 3.2.2.5.1. This model also uses the Diablo 96 character plastic daisy print wheel in both 10 and 12 pitch, and accepts character commands in the form of a Diablo modified ASCII code.

1.2.3 Model 1355WP

This model is a variation of the Model 1355HS, with a modified print hammer system and a special print wheel housing. It uses both the XEROX and the Diablo metalized word processor and proportional space print wheels in 10 and 12 pitch. It features ribbon advance proportional to the width of the character to be printed, and produces superb print quality at speeds up to 40 characters per second.

The Model 1355WP utilizes the Model 1345A interface without alteration. The jumper wire options mentioned for the Model 1345A printer are offered with this model by similar names but with different results, due to differences in the 1355WP printer's internal program. These options are discussed in subsection 3.2.2.5.2.

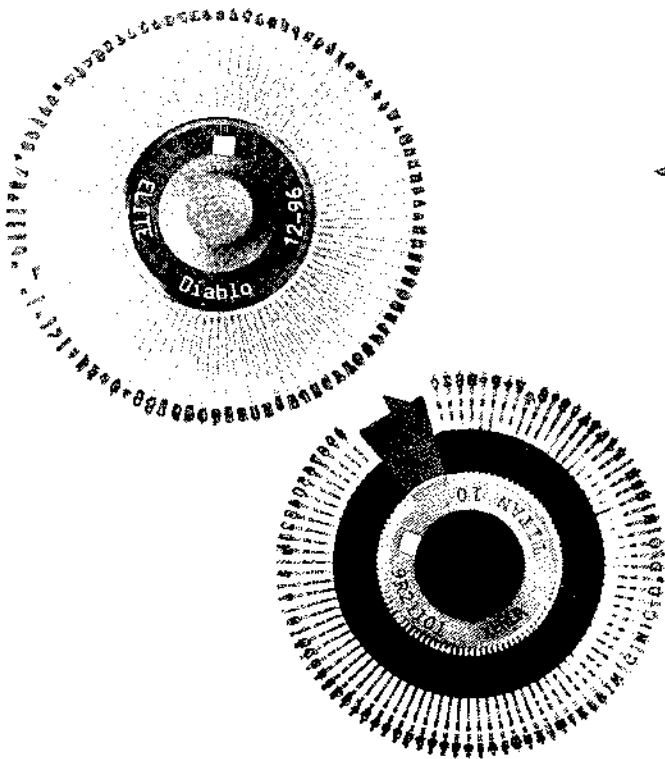

Figure 1-2. TYPICAL PRINT WHEELS



Figure 1-3. PRINT WHEEL SHIELDS

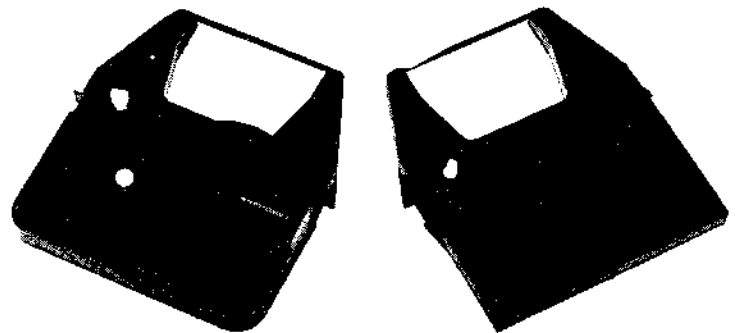

Figure 1-4. RIBBON CARTRIDGES

1.2.4 Print Wheels and Printing

Refer to Figures 1-2 and 1-3, and to Diablo Publication No. 90007-XX Printer Supplies Catalog.

The inner portion of the HyType II's carriage mechanism tilts forward (away from the platen) as shown, for easy exchange of print wheels. The operator may select the type of print wheel to be used as well as the type style or character font from the many wheels presently available. These include many styles of English and other languages, scientific, APL, and OCR character sets ranging from 88 character word processor to 96 character plastic print wheels.

1.2.5 Diablo Ribbon Cartridges and Ribbon Drive

Refer to Figure 1-4, and to Diablo Publication No. 90007-XX Printer Supplies Catalog.

The print ribbons for all Diablo HyType Printers are housed in snap-in cartridges for quick, clean, simple replacement. The operator never has to touch a Diablo ribbon. Series 1300 HyType II cartridges have a greatly increased capacity over those for the predecessor HyType I Printer.

Ribbon drive is by means of a processor controlled drive system and a ribbon drive stepper motor which connects to the cartridge's internal drive system when the cartridge is in position on top of the carriage.

Model 1345A: The ribbon drive control logic normally advances the ribbon two steps. One of the operating options available gives the controller access to the printer's internal program to directly command a ribbon movement of either one or two steps per character printed.

Model 1355HS: Ribbon advance is always two steps per character printed

Model 1355WP: Ribbon advance is normally proportional to the width of the character printed in accordance with values for each character incorporated in an internal ROM table. The user option here is access to the printer's internal program to directly command ribbon advance.

1.2.6 Carriage Operation

Carriage movement is bidirectional along the horizontal print line, with the carriage velocity a function of the distance to be traveled to the next print position. The design of the carriage and its drive system allows movement in either direction with equal ease and speed, enabling printing in either direction.

1.2.7 Paper Feed

Paper feed is bidirectional. Paper feed options include friction feed forward (up) only, pin feed forward (up) and forward/reverse (down), and tractor feed forward and forward/reverse. The paper carrier, which includes the platen and drive train, can be adjusted by the op-

erator (Platen Position Lever) for paper thickness up to 6 part multiple forms.

The split platen paper feed option involves installation of a special circuit board and a second paper feed drive motor and gear train on the left end of the main frame. Use of a special friction feed or pin feed split platen is required.

1.3 PERFORMANCE SPECIFICATIONS

1.3.1 Print Speed

Model 1345A: Up to 45 characters per second typical on an average text in 12 pitch mode.

Model 1355HS: Up to 55 characters per second typical on an average text in 12 pitch mode.

Model 1355WP: Up to 40 characters per second typical on an average text in 12 pitch mode.

See subsection 1.4.

1.3.2 Character Set

Model 1345A: 96 characters

Model 1355HS: 96 characters

Model 1355WP: 88 characters normally. 92 and 96 character sets available.

1.3.3 Carriage Movement

Carriage Return: 300 msec maximum

Tabulation: Right or left

Column Spacing: 60 positions per inch normally, 120 positions per inch when selected by the controller.

Print Line: 13.1 inches (332.74 mm)
= 132 columns in 10 pitch
= 158 columns in 12 pitch

1.3.4 Paper Handling

Paper Width: Standard Platen = 14-3/8" (365.13 mm) maximum width between drive holes.
Forms Tractor = 15-7/8" (403.23 mm) maximum width between drive holes.
Standard manifold paper is 14-3/8" (365.13 mm) between drive holes.

Paper Thickness: Standard settings of the Platen Position Lever permit single sheet or multiple form paper thickness to .027" (.686 mm).

Paper Feed: Forward (up) or reverse (down). Reverse only with bidirectional pin feed platens or forms tractors.

Paper Feed Speed: 4" (101.6 mm) per second plus 50 msec typical settling delay.

Line Spacing: 48 positions per inch (25.4 mm) nominal.

1.3.5 Power Requirements

Model 1345A: Current requirements

	<u>Idle</u>	<u>Printing</u>
+5V	3 Amps	3 Amps
+15VS	.50 Amp	.50 Amp
-15VS	.25 Amp	.25 AMP
+/-15VD	1.5 Amps	4.50 Amps

(User may specify the optional Internal Power Supply, or external Power Supply Models 215 or 1329)

Current Demand Envelope, +/-15VD Supply

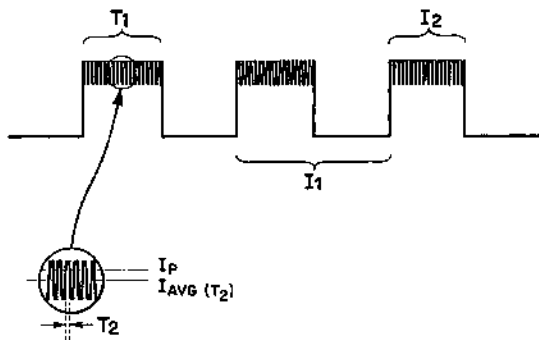

- I_1 = 4.5 Amps Average
- I_2 = 9 Amps @ 40% Duty Cycle
- T_1 = 70 milliseconds maximum
- I_p = 14 Amps @ 40% Duty Cycle
- T_2 = 30 microseconds

Model 1355HS: Current requirements

	<u>Idle</u>	<u>Printing</u>
+5V	3 Amps	3 Amps
+15VS	.50 Amp	.50 Amp
-15VS	.25 Amp	.25 Amp
+/-15VD	1.5 Amps	5 Amps

(User may specify the optional Internal Power Supply, or external Power Supply Models 215 or 1329)

Current Demand Envelope, +/-15VD Supply

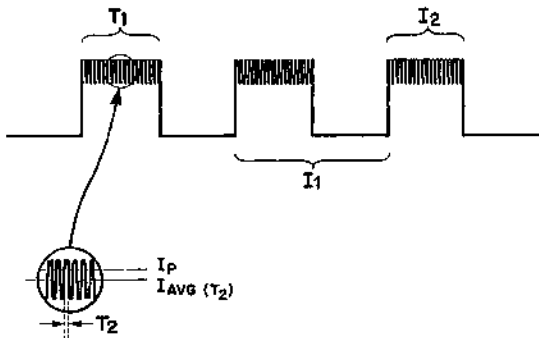

- I_1 = 5 Amps Average
- I_2 = 11 Amps @ 40% Duty Cycle
- T_1 = 70 milliseconds maximum
- I_p = 16 Amps @ 40% Duty Cycle
- T_2 = 30 microseconds

Model 1355WP: Current requirements

	<u>Idle</u>	<u>Printing</u>
+5V	3 Amps	3 Amps
+15VS	.50 Amp	.50 Amp
-15VS	.25 Amp	.25 Amp
+/-15VD	1.50Amps	4.50 Amps

(User may specify the optional Internal Power Supply, or external Power Supply Models 215 or 1329)

Current Demand Envelope, +/-15VD Supply

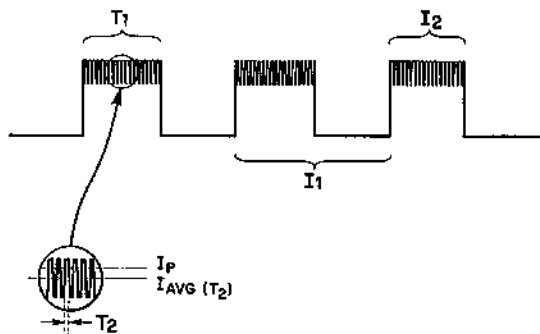

- I₁ = 4.5 Amps Average
- I₂ = 9 Amps @ 40% Duty Cycle
- T₁ = 70 milliseconds maximum
- I_p = 14 Amps @ 40% Duty Cycle
- T₂ = 30 microseconds

1.3.6 Features

Platens

- # Single Friction Feed
- # Split Friction Feed
- # Bidirectional Pin Feed (Dual Cam)
- # Single Pin Feed
- # Split Pin Feed

Auxilliary Feed

- # Unidirectional Forms Tractor
- # Auto Front Feed **
- # Mechanical Front Feed
- # Bidirectional Forms Tractor
- # HyFeed Sheet Feeder **

(** = these require connection to printer power)

Ribbon Element

- # Interchangeable Cartridge type with end of ribbon indicator on the film base ribbons.

Ribbon Type

- # Single- and two-color recirculating cloth (up to 1 million impressions)
- # Multistrike film base carbon (185,000 impressions)

1.3.7 Environment

Printer Ambient Temperature

Storage

-20°F (-29°C) to +135°F (+57°C)

Operating

+45°F (+7°C) to +105°F (+40°C)

Printer Ambient Relative Humidity
Storage
0 to 90%
Operating (without condensation)
10 to 80%

1.3.8 Ribbon Position Considerations

Maximum Ribbon Position Change Rate
= 5 per second
Maximum Duty Cycle
= 30% (Not to exceed 400 sequential ribbon position changes
between rest periods)

CAUTION:

The user can expect a significant rise in temperature in and around the Ribbon Lift Solenoids when operating at the 5 position change per second rate, and should therefore limit the number of operations to 400 between rest periods, for the 30% Duty Cycle. Failure to observe these limits may result in the temperature rise becoming excessive.

1.4 PRINT SPEED MEASUREMENTS

The following subsections detail the procedures used for determining print speed performance for each of the several models of the Series 1300 HyType II Printer.

1.4.1 Performance Criteria

The printer is to be operated in the over-lapped mode (see subsection 3.3), 12 pitch, 12-bit interface, with the test text printed unidirectionally with carriage return and paper feed commands between succeeding lines of text. No jumper options are to be exercised (see subsection 3.2.2.5).

All printing times and/or character counts are to start at column 0 following any Restore function, with character counts to include all characters and spaces. The combined carriage return and paper feed motions shall count as one (1) character. Host system software overhead is to be excluded from any recorded printing time. Any host system real clock time to be used shall have a resolution no greater than 10 msec in the LSD, and an overall accuracy of at least +/- .1% +/- 1 count in the LSD.

1.4.2 Performance Tests

Two texts shall be used to measure print speed; the Shannon text, and the 3A text.

1.4.2.1 The 3A Text

In the 3A text, a capital A is printed in columns 0, 1, and 2 followed by a tab to column 4 where the sequence is repeated. This sequence is repeated a total of 33 times, ending with the carriage positioned at column 132, for a total character count of 132.

1.4.2.2 The Shannon Text

The head and in frontal attack on an english writer that the character of this point is therefore another method for the letters that the time of who ever told the problem for an unexpected. The head and in frontal attack on an english writer that the character of this point is therefore another method for the letters that the time of who ever told the problem for an unexpected. The head and in frontal attack on an english writer that the character of this point is therefore another method for the letters that the time of who ever told the problem for an unexpected.

1.4.2.3 Print Speeds

Model 1345A: The printer shall print the 3A text as described in a maximum time of 2.93 seconds, corresponding to 45 characters per second.

The printer shall print the Shannon text as shown in a maximum time of 14.35 seconds, corresponding to 40 characters per second. (16.88 seconds/34cps for the Spec D Model)

Model 1355HS: The printer shall print the 3A text as described in a maximum time of 2.4 seconds, corresponding to 55 characters per second.

The printer shall print the Shannon text as shown in a maximum time of 11.48 seconds, corresponding to 50 characters per second.

Model 1355WP: The printer shall print the 3A text as described in a maximum time of 2.93 seconds, corresponding to 45 characters per second.

The printer shall print the Shannon text as shown in a maximum time of 15.11 seconds, corresponding to 38 characters per second.



SECTION 2

INSTALLATION AND OPERATION

2.1 INSTALLATION

2.1.1 Space Requirements

Basic models of the HyType II Printer are shipped without covers where the user intends to incorporate the printer into his cabinet. Diablo offers cover sets for its printers, as accessories, which are suitable for most open installations. Figure 2-1 provides the external dimensions of the basic printer needed by those users who wish to design their own enclosures. Figures 2-2 thru 2-6 provide the external dimensions needed to plan space for units shipped with accessory Diablo RO and KSR cover sets. Also included in these illustrations are the dimensions of the several optional forms handling accessories which are currently available.

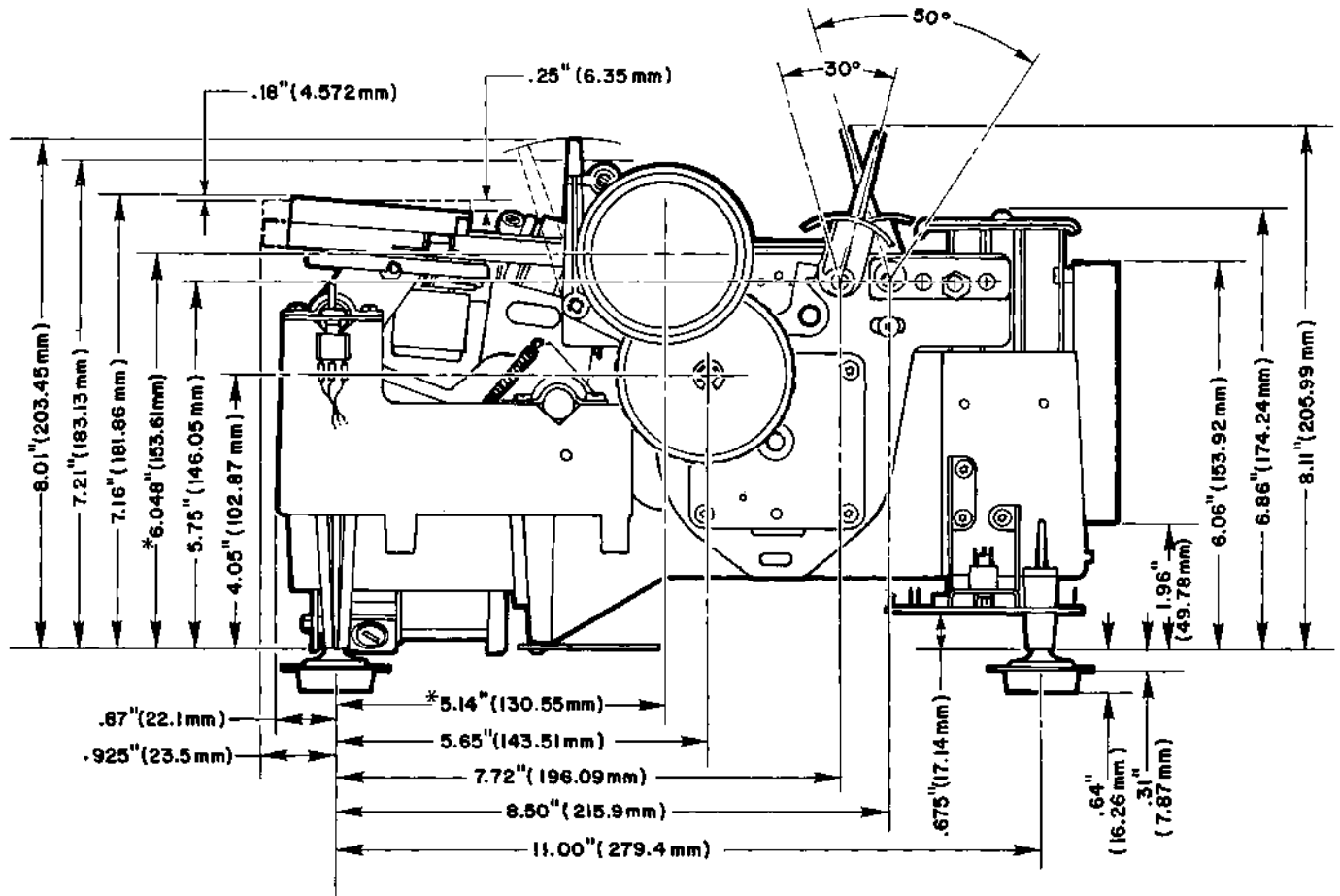

NOTES: All dimensions are nominal, dimensions shown in parentheses are in millimeters
* = Adjustable

Figure 2-1A
HYTYPE II EXTERNAL DIMENSIONS

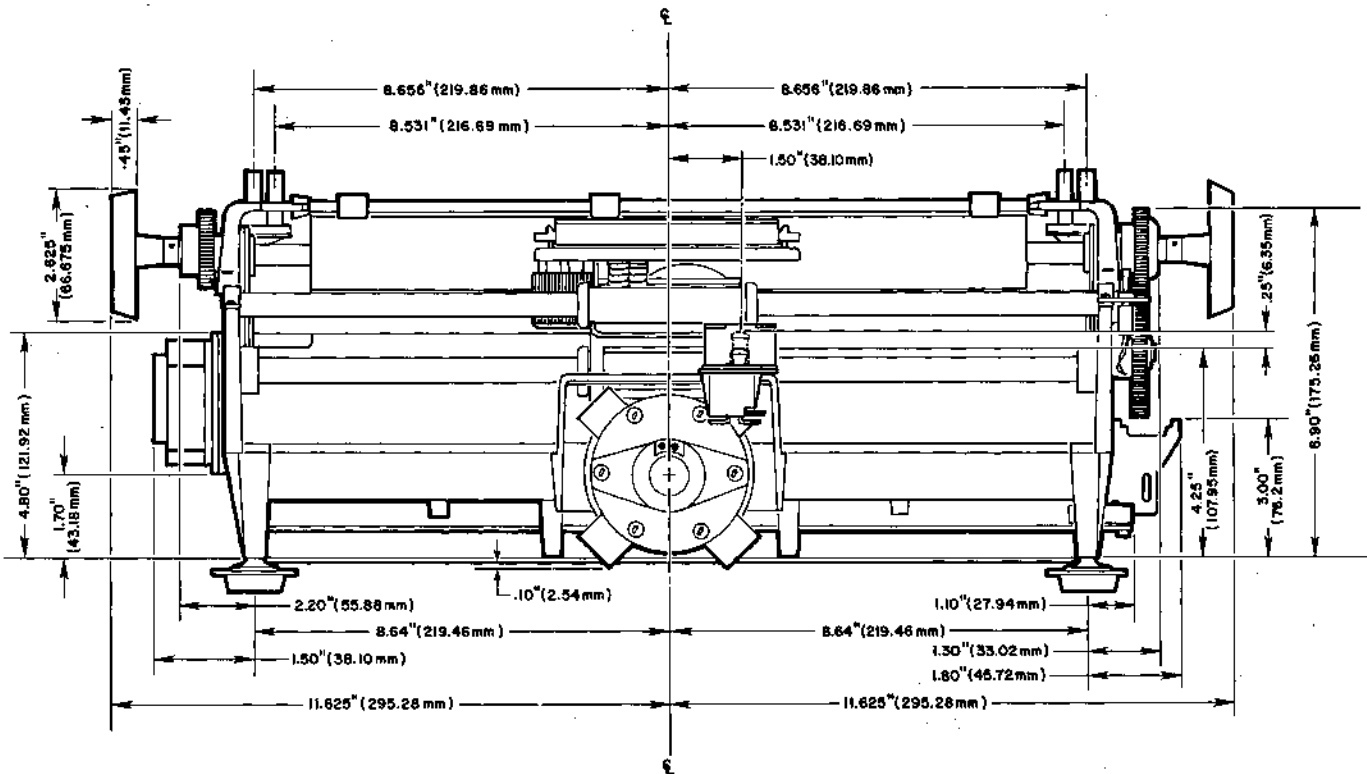
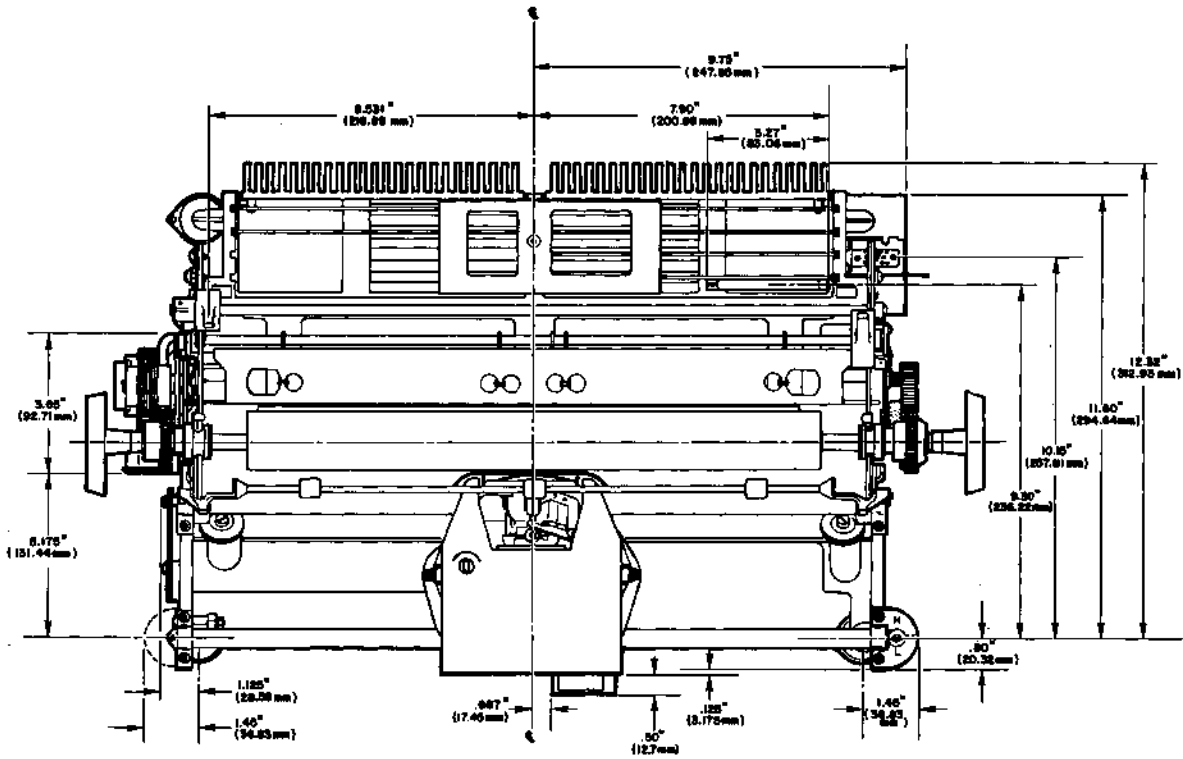

NOTES: All dimensions are nominal, dimensions shown in parentheses are in millimeters
 * = Adjustable

Figure 2-1B HyTYPE II EXTERNAL DIMENSIONS

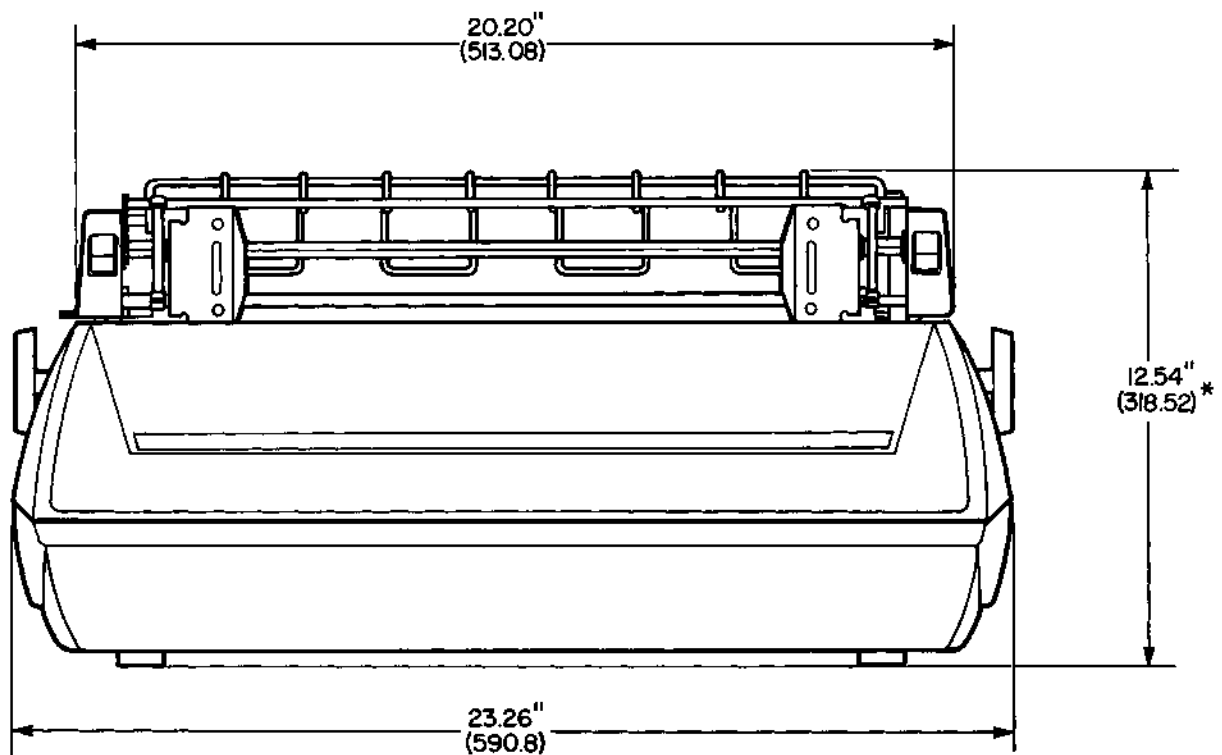
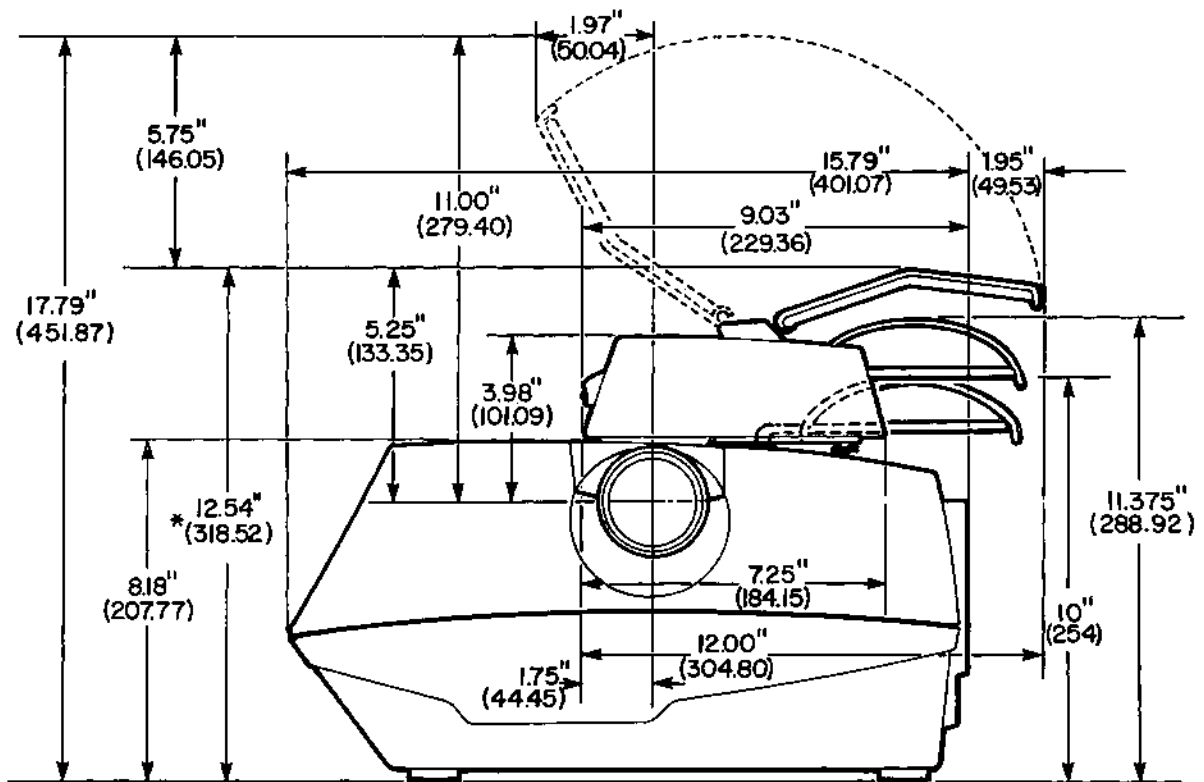

NOTES: All dimensions are nominal, dimensions shown in parentheses are in millimeters
 * = Adjustable

Figure 2-2
DIABLO UNIDIRECTIONAL FORMS TRACTOR

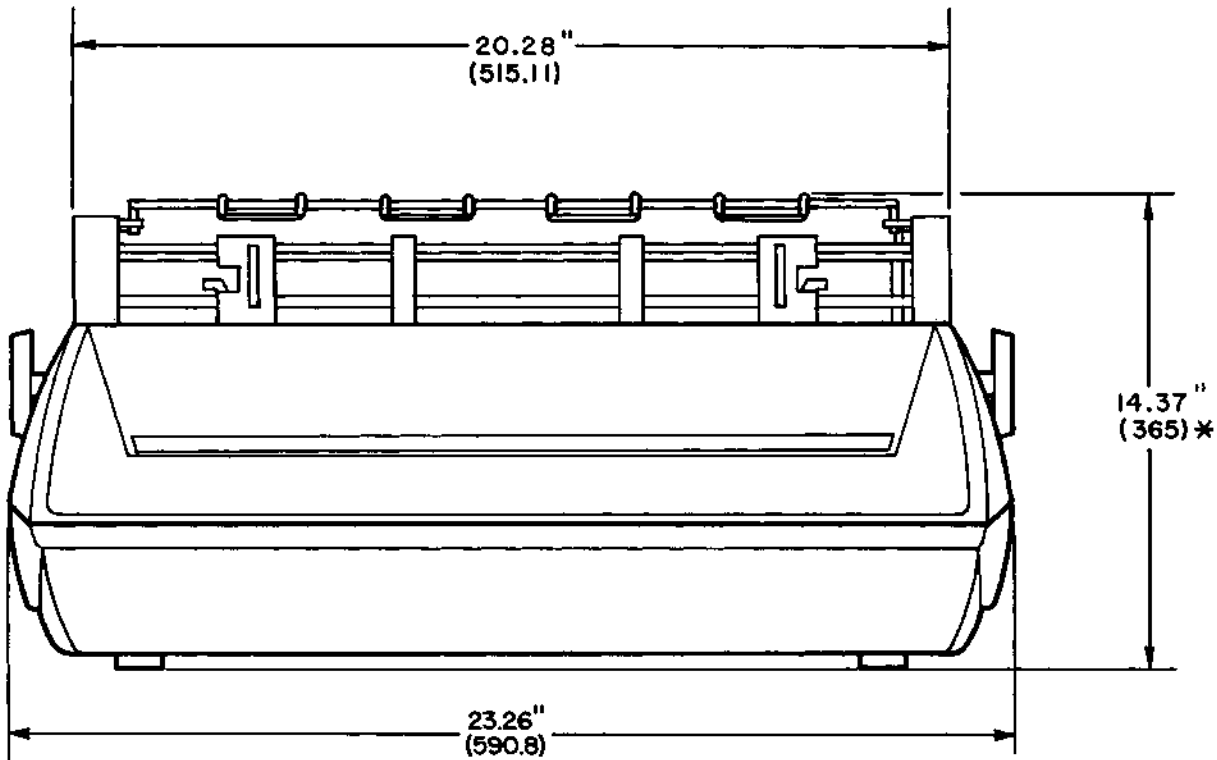
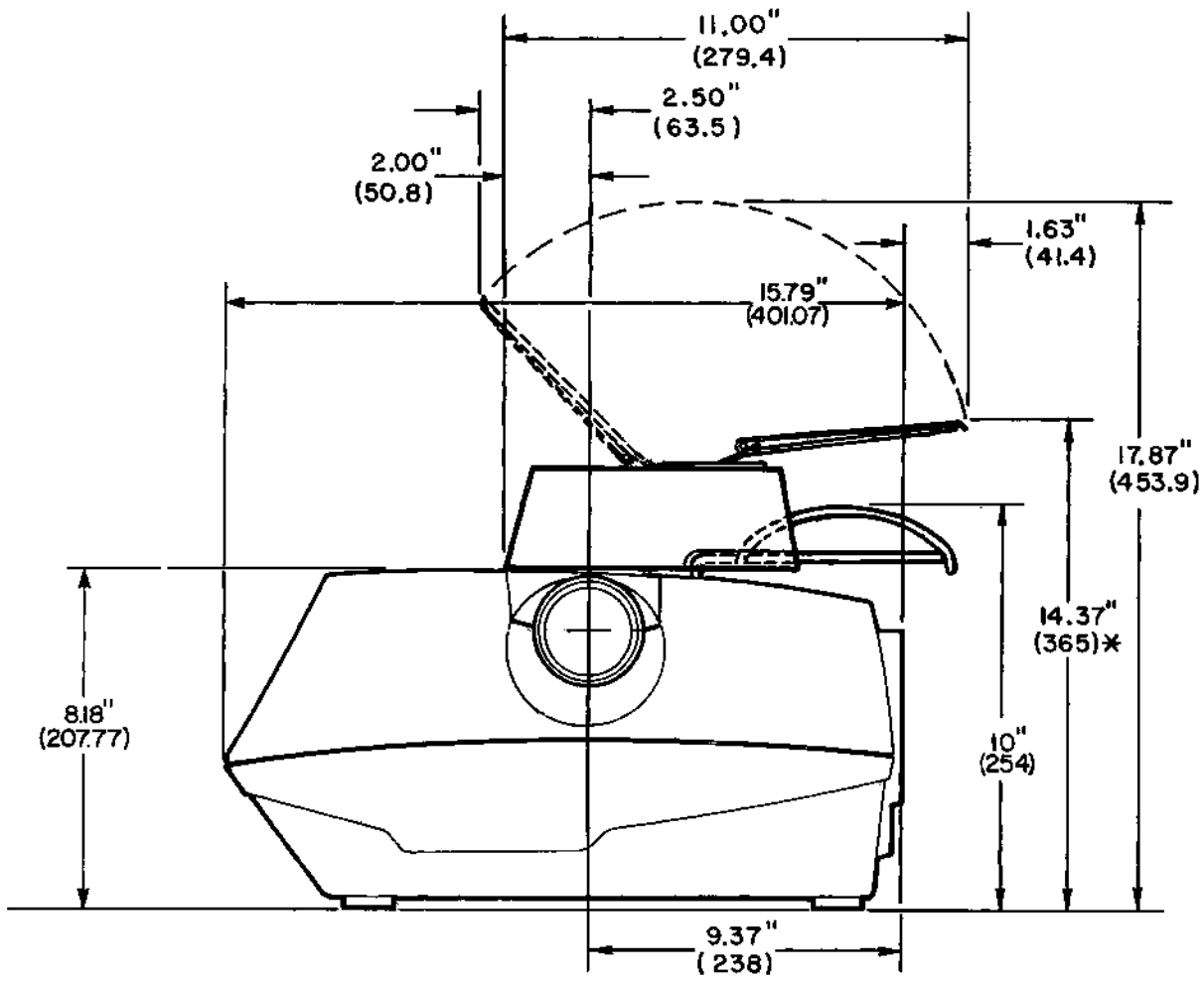

NOTES: All dimensions are nominal, dimensions shown in parentheses are in millimeters
 * = Adjustable

Figure 2-3
DIABLO BIDIRECTIONAL FORMS TRACTOR

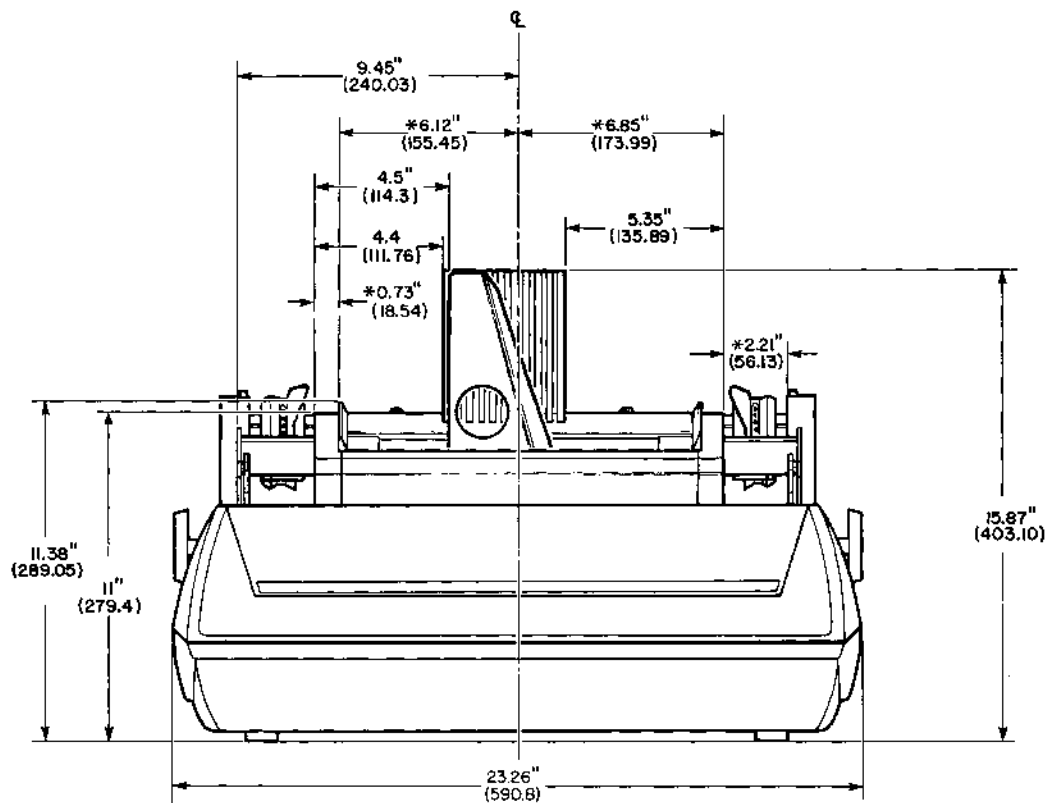
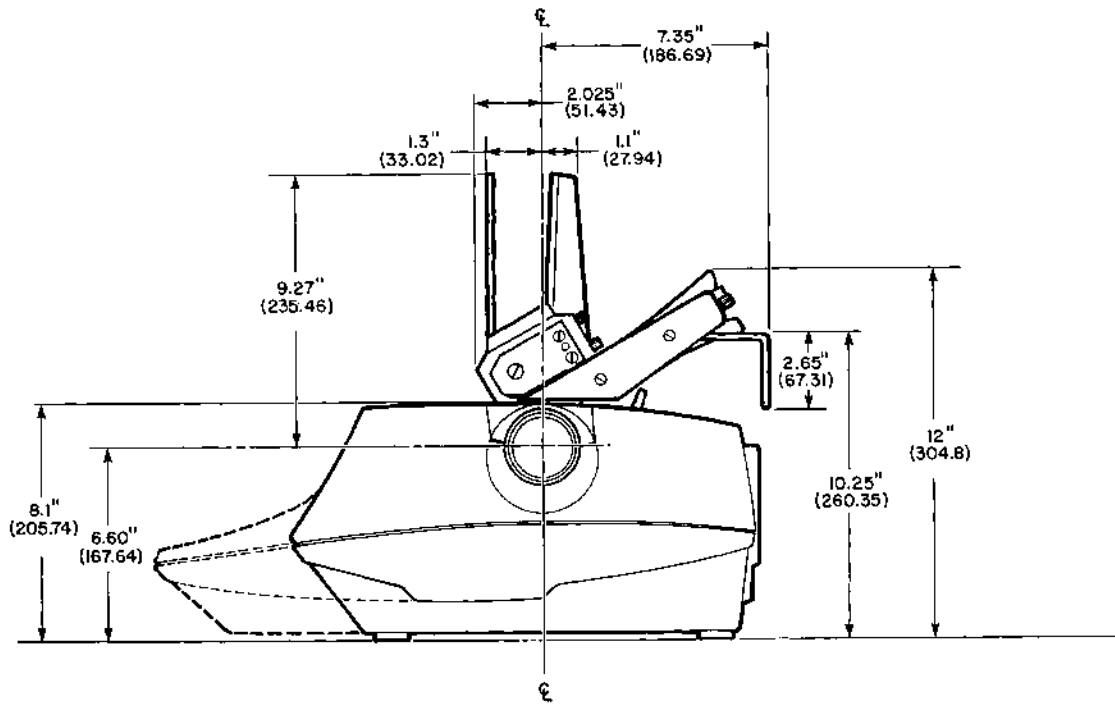

NOTES: ALL DIMENSIONS ARE NOMINAL.
 DIMENSIONS SHOWN IN PARENTHESES ARE IN MILLIMETERS
 * = ADJUSTABLE

Figure 2-4
AUTO FRONT FEED and BIDIRECTIONAL FORMS TRACTOR

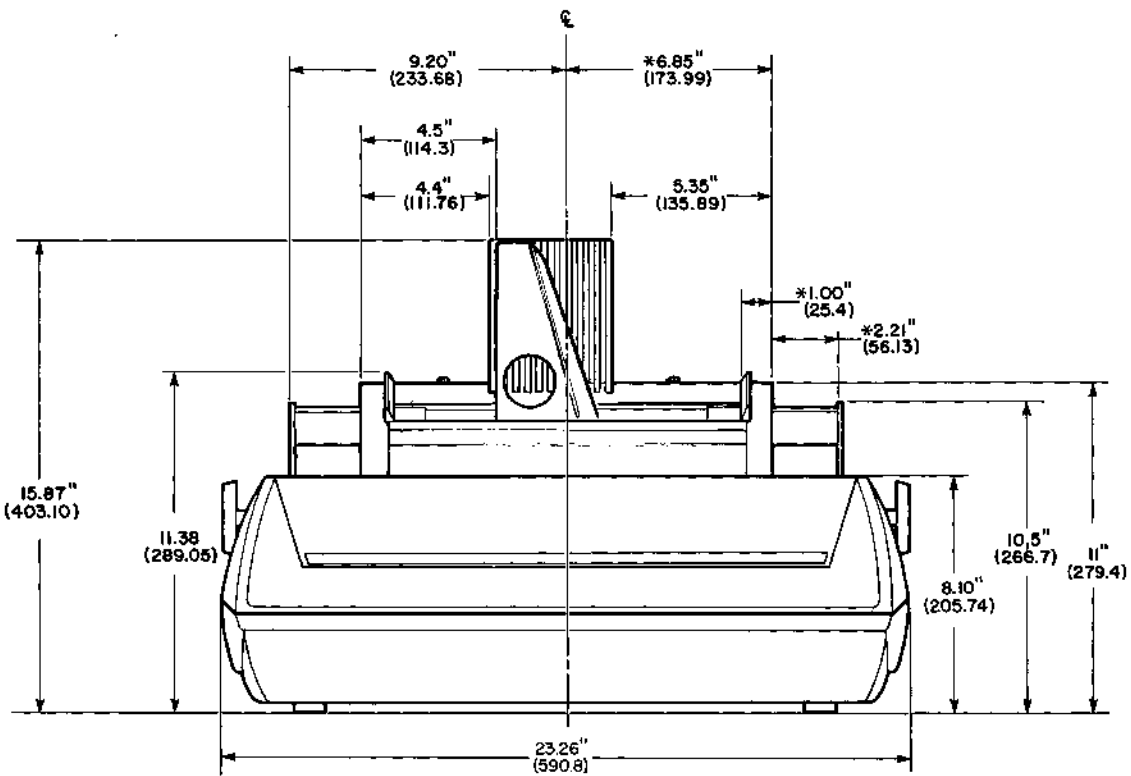
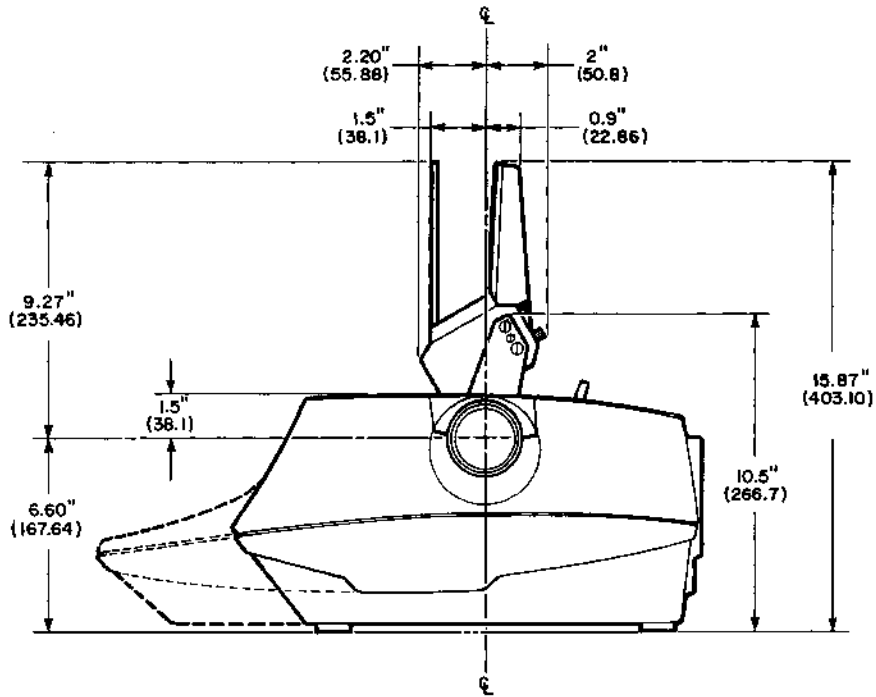

NOTES: ALL DIMENSIONS ARE NOMINAL,
 DIMENSIONS SHOWN IN PARENTHESES ARE IN MILLIMETERS
 * = ADJUSTABLE

Figure 2-5
MECHANICAL FRONT FEED

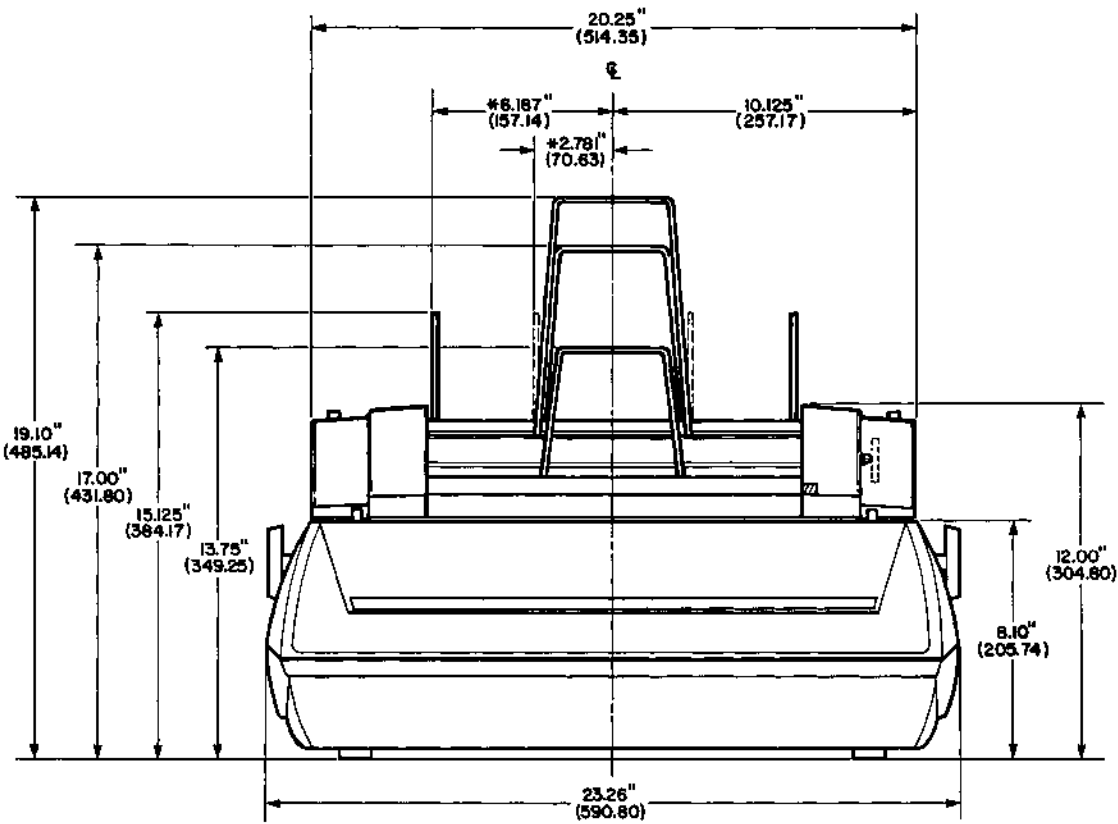
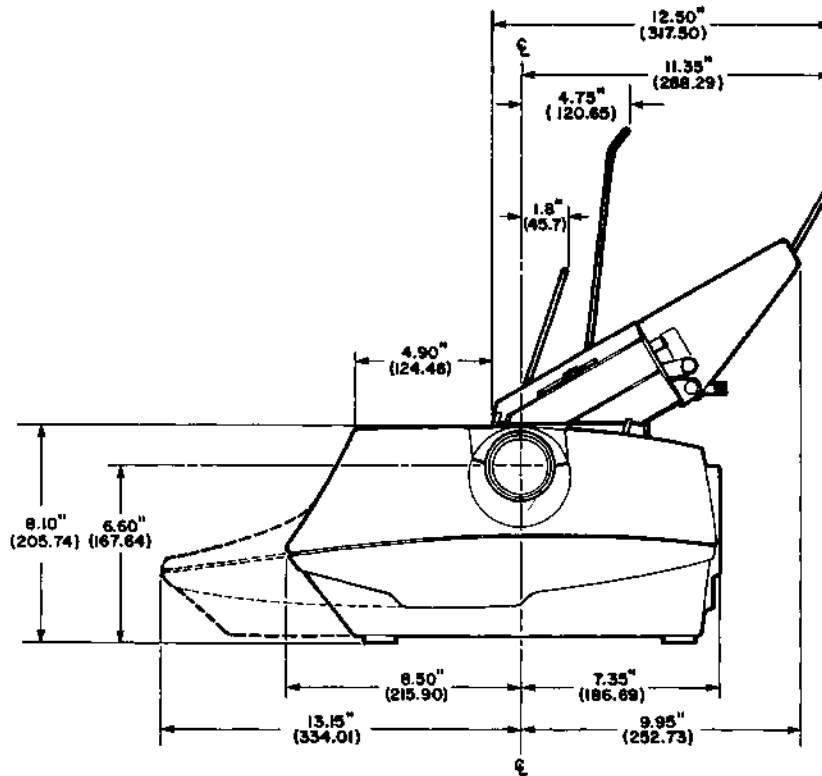

NOTES: All dimensions are nominal, dimensions shown in parentheses are in millimeters
 * = Adjustable

Figure 2-6
HyFEED SHEET FEEDER

2.1.2 Mounting

Each printer is supplied with shock mounts, including those shipped in Diablo cover sets. Users are encouraged to use these, or their mounting holes (8-32 thread) when installing the unit in its operating position. The threaded holes used for shipping restraint SHOULD NOT be used for permanent printer mounting.

2.1.3 Power Supply Requirements

The HyType II Printer requires +/-15 and +5 Volts dc. Diablo's Model 215 Power Supply, shown in Figure 2-7, is an external supply designed to meet the power requirements of all HyType II Printers. It plugs directly into the printer's power connector.

Diablo Model 1329 Power Supply, similar to Model 215, may also be used to power Models 1345A and 1355WP Printers. This model is not recommended for use with Model 1355HS due to higher current demands.

A typical optional Internal Power Supply is shown in Figure 2-8. The several different supplies currently available all mount inside the printer's main frame and connect to the printer's Motherboard power connector(s). An optional cooling fan mounts in the opening in the left end of the frame.

These power supplies are all strappable for operation with either 115V or 230V ac sources. The internal power supplies can accommodate power sources between -

90-130V / 180-260V ac , 47-63 Hz.

In the case of the internal supplies, the associated cooling fan connects across the ac input, and users should make certain the fan's voltage requirements match the source to be used.

A power on-off switch is not provided with these supplies. Power is to be controlled either from a control panel switch or from the host system. Users are cautioned NOT to connect or remove the power interconnecting cable while power is on, or extensive damage may occur.

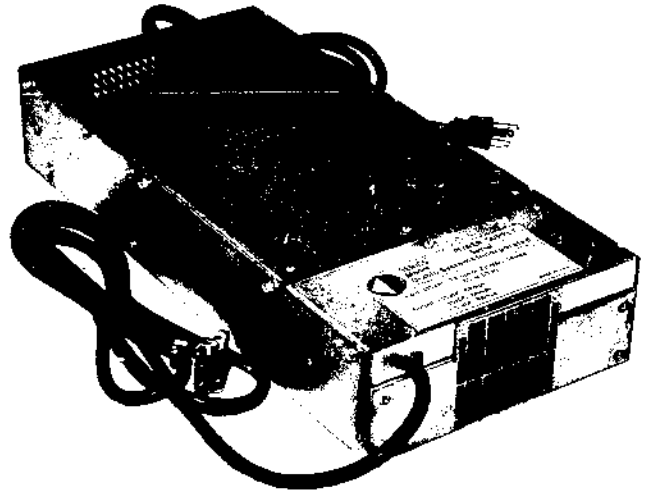

Figure 2-7
MODEL 215 POWER SUPPLY

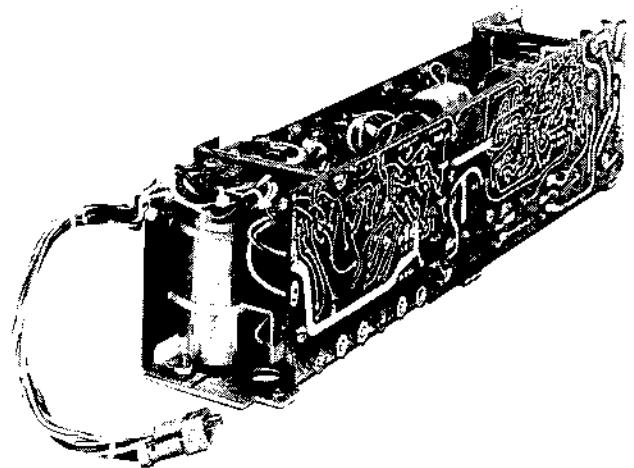

Figure 2-8
TYPICAL INTERNAL POWER SUPPLY

DC power must not be applied to the printer or to any of its components by switch or relay closure. Application of power must always begin at 0 volt. If power is to be reapplied after a momentary interruption, such application should be delayed to allow all power levels to decay to 0 volt. Following application (or reapplication) of power each voltage must rise to 95% of its final level in not less than 6 msec (to limit destructive inrush current) nor more than 200 msec (to prevent capacitor leakage from causing a printer RESET condition) to ensure proper sequencing.

In addition, if an unregulated bulk rectifier type power supply is to be used, the minimum output capacitance required to prevent sagging on the +15 and -15 volt supplies is 51,000 mFd. When a power supply with active regulation is used to provide the +/-15 volts, its output impedance at 20 kHz must be low enough to reduce the noise produced by dynamic load switching to less than +/-0.5 volt. The minimum capacitance recommended is 2000 mFd.

Voltage tolerance of the 15 volt supplies is +/-5% static or +/-8% full printing demand. Voltage tolerance of the +5 volt supply is +/-2% RMS, +/-3% peak-to-peak.

Power dissipation is less than 250W worst case operation.

NOTE: Diablo Systems, Inc. assumes no liability for degraded unit operation or damage resulting from improper application of power to the unit from power sources not manufactured or furnished by it.

POWER SUPPLY SEQUENCING

Power On Sequence:

All dc voltages must rise to within 95% of their final value in not less than 6 msec, nor more than 200 msec. The last voltage to reach 95% of its final value must do so no later than 20 msec after the first voltage to do so. The +/-15 volt supply outputs must be equal within 1.5 volts at any point in their rise time.

Power Off Sequence:

The +/-15 volt supply outputs must be equal within 1.5 volts at any point in their fall time.

2.1.4 Grounding Requirements

On all HyType II Printers, signal ground is available at Terminal T3 on the Motherboard PCB. Each printer is shipped with a jumper wire installed between Terminal T3 and a nearby chassis ground point on the printer's main frame. Figure 2-9A depicts this condition.

For optimum noise immunity, signal ground and chassis ground should be tied together at the source, which is within the host system. Therefore, the jumper wire between T3 and chassis ground should be removed, and signal ground should be tied to chassis ground at the source as shown in Figure 2-9B. A new wire should be installed and used then to

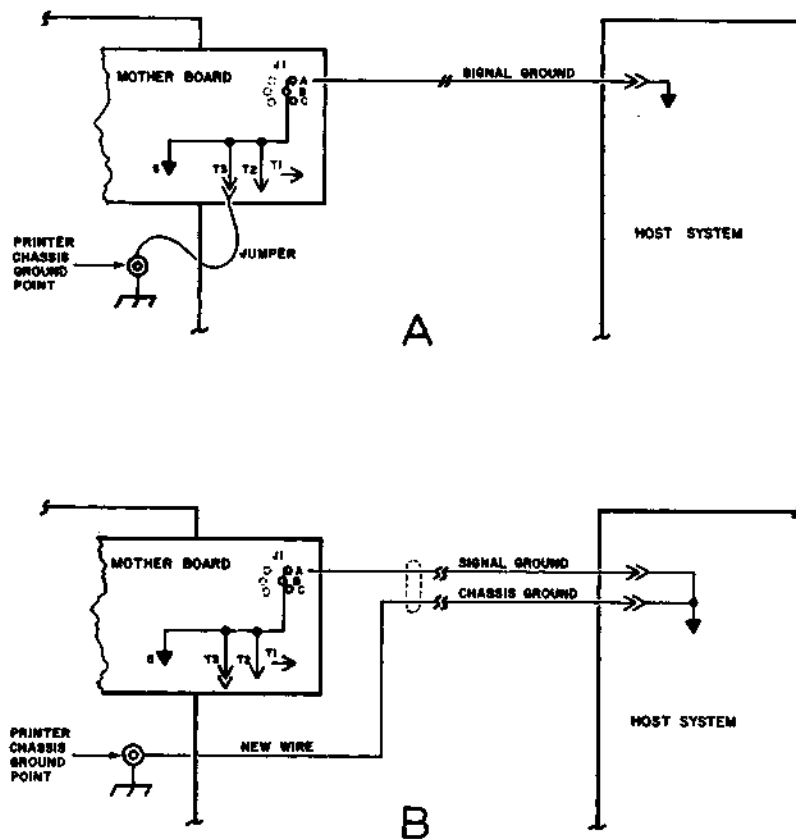

Figure 2-9 NOISE IMMUNITY GROUNDING

tie printer chassis ground to source chassis ground. In addition, care should be taken to strap any cover halves together, and to the printer chassis ground.

2.1.5 Ventilation

The HyType II Printer is designed so that all heat generating components are located for optimum heat dissipation thru natural convection. Care should be taken to allow adequate air circulation both around the rear heat sinks and up thru the bottom of the unit. When using continuous forms, it is necessary to prevent these forms from blocking air circulation, particularly where the printer is enclosed in covers or a cabinet. Diablo covers are properly vented, and include a 2 inch (50.8 mm) high rack support for continuous forms, to provide adequate machine cooling under normal use in a standard office environment.

If the anticipated application environment will exceed 106°F (41°C)* ambient, or if the printer is to be exposed to constant usage, the user should provide forced air cooling of at least 50 cfm in the printer's electronics compartment.

(* = $156^{\circ}\text{F}/69^{\circ}\text{C}$ internally observed between the topmost edges of any two PCB's)

2.1.6 Location

The HyType II Printer weighs about 27 pounds (12.15 kg) without covers and about 37 pounds (16.65 kg) with covers. The optional internal power supply adds about 5 pounds (2.25 kg). In operation, the rapid movement of the carriage generates a sideways thrust proportional to carriage acceleration. This, plus the printer's weight, should be kept in mind when planning its location.

2.2 INTERCONNECTING CABLES

2.2.1 The Power Cable

An interconnecting power cable should not exceed 6 feet (1.83 m) in length, without considering the current carrying capacity of the wire. The wire sizes given below are adequate for a 6 foot (1.83 m) power cable for a Series 1300 HyType II Printer:

+/-15V High Current	14 AWG
+/-15V Low Current	16 AWG
+ 5V	14 AWG
Ground Return	10 AWG Flat Braid

The power connector parts listed below should be used to ensure proper mating with the printer's power connector located on the machine's right rear corner:

Connector Body = Winchester MRAC14SJTC13 (Diablo P/N 10534-10)
 Contacts, Socket (F) = Winchester 100-51014S (Diablo P/N 10525-11)

(See NOTE, subsection 2.2.3)

In the Series 1300 HyType II Printer, both +15 and -15 volts dc are distributed separately to the high current driver and low current logic circuits. Table 2-1 lists the pin assignments to be used in construction of a compatible power cable, and Figure 2-10 shows the wire side pin arrangement for the connector body listed above.

TABLE 2-1
 POWER CABLE PIN ASSIGNMENTS

P4 POWER CONNECTOR	DESCRIPTION	
A	+15V Ground	} connected at Printer
B	-15V Ground	
C	+ 5V Ground	
D	+15VS (Low Current)	
E	+15VD (High Current)	
F	+15VS (Low Current)	
G	(Not Used)	
H	+15VD (High Current)	
J	+ 5V	
K	+15VS (Low Current)	
L	+ 5V	
M	-15VD (High Current)	
N	-15VS (Low Current)	
P	-15VD (High Current)	
R	-15VS (Low Current)	

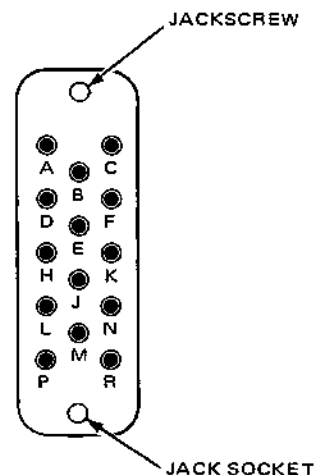

Figure 2-10
 POWER CONNECTOR PIN ARRANGEMENT
 (wire side)

2.2.2 The Input/Output (I/O) Interconnecting Cable

The I/O interconnecting cable consists of a flat type 50 conductor cable with 28 or 30 AWG conductors. Maximum tested length is 25 feet (7.6 m).

The cable parts listed below should be used to construct a compatible I/O cable for the Series 1300 HyType II Printer. Use of these parts will ensure proper entry of the cable into the Printer's structure and mating with the I/O connector mounted near the top edge of the Logic 1 PCB:

Cable, 50 Conductor Flat, 28 AWG - Diablo P/N 40549
 Connector, Socket (F), Flat Cable - 3M P/N 3425-0000 (Diablo P/N 10776)

Table 2-2 below lists the pin assignment for the I/O cable, and Figure 2-11 shows the wire side pin arrangement for the connector body listed above.

TABLE 2-2
 I/O CABLE WIRE DEDICATION

P7 CONNECTOR	SIGNAL DESCRIPTION	P7 CONNECTOR	SIGNAL DESCRIPTION
1	--Data Bit 10 (512)	26	--Carriage Ready
2	Ground	27	--P.W. Ready
3	--Paper Out	28	--Printer Ready
4	--End Of Ribbon	29	Spare/Ground 2
5	--Cover Open	30	Ground
6	Spare/Ground 1	31	Ground
7	--Option Status	32	Ground
8	Ground	33	--Data Bit 4 (8)
9	--Data Bit 11 (1024)	34	--P.F. Ready
10	--Data Bit 12 (2048) (½ Space)	35	Ground
11	Ground	36	--Data Bit 2 (2)
12	--Check	37	--Data Bit 1 (1)
13	--Restore	38	Ground
14	Ground	39	--Data Bit 3 (4)
15	--P.F. Strobe	40	--Data Bit 5 (16)
16	Ground	41	Ground
17	--Carriage Strobe	42	--Data Bit 6 (32)
18	Ground	43	--Data Bit 7 (64)
19	--Option Strobe	44	Ground
20	Ground	45	--Data Bit 8 (128)
21	--P.W. Strobe	46	--Data Bit 9 (256)
22	Ground	47	Ground
23	--Ribbon Lift	48	+5V (Ref. Out)
24	--Select Printer	49	+5V (Ref. Out)
25	Ground	50	Spare/Ground 3

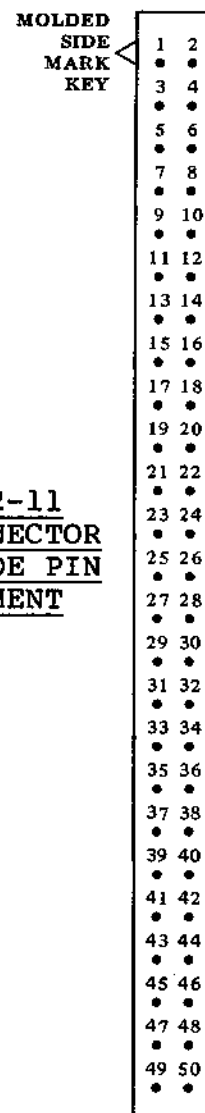

Figure 2-11
I/O CONNECTOR
WIRE SIDE PIN
ARRANGEMENT

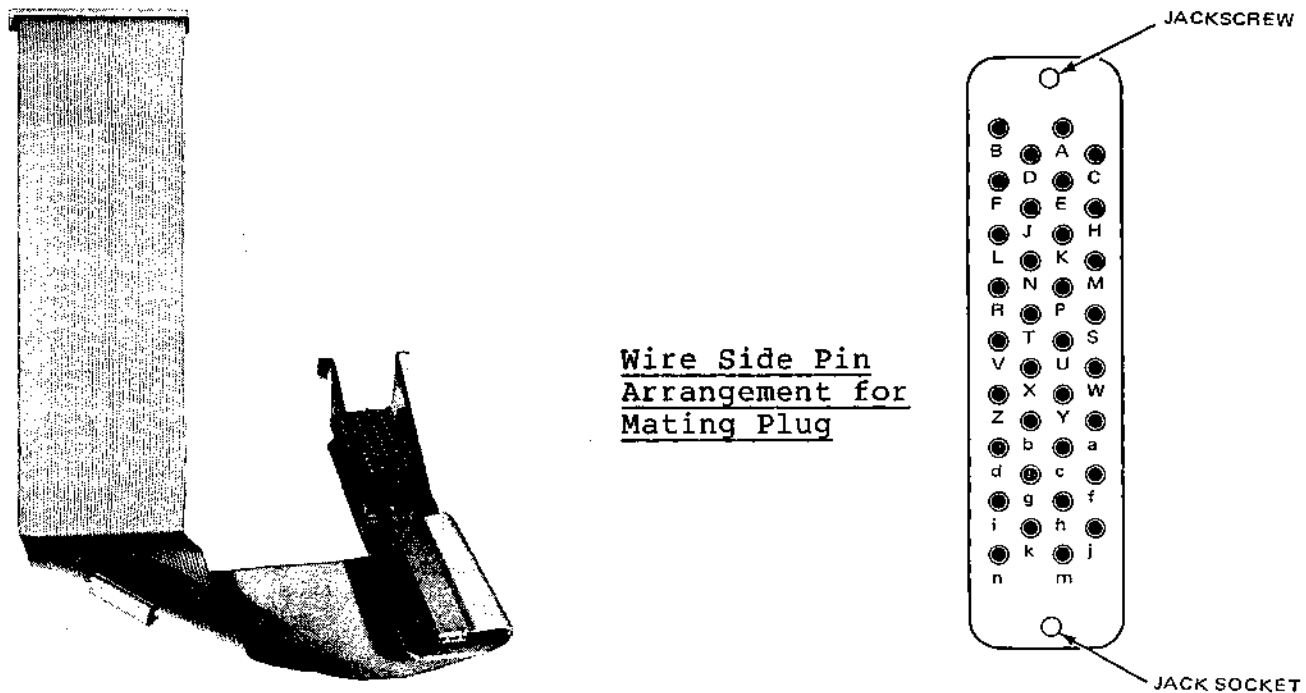

Figure 2-12 HyTYPE II to HyTYPE I ADAPTER CABLE

2.2.3 The Adapter Cable

Figure 2-12 shows a special adapter cable, Diablo P/N 40508-XX, which allows the HyType II Printer to interface with installations designed for HyType I. The illustration also includes the wire side pin arrangement for a mating plug for this adapter. The components for this plug are listed below:

- Connector Body less contacts = Winchester MRAC34SJTDH
Diablo P/N 10669-02
- Contacts, Socket (F) = Winchester 100-51024S
Diablo P/N 10525-13

NOTE: Those users who wish to construct both power and interface cables may wish to order a Diablo Printer Interconnect Kit, P/N 20608. This kit contains complete parts for both connectors. The actual cable is ordered separately.

Figure 2-13 on the next page lists the I/O plug pin assignments for two versions of HyType I installations.

This adapter assembly mounts on a bracket on the right side of the printer, just in front of the power connector. Its flat cable goes under the printer and up thru the bottom - in front of the first PCB (Logic 1) - where it plugs into the Logic 1 PCB I/O connector J7 near the top edge of the PCB. The HyType I I/O cable then plugs into the adapter. This installation is easily accommodated inside Diablo cover sets.

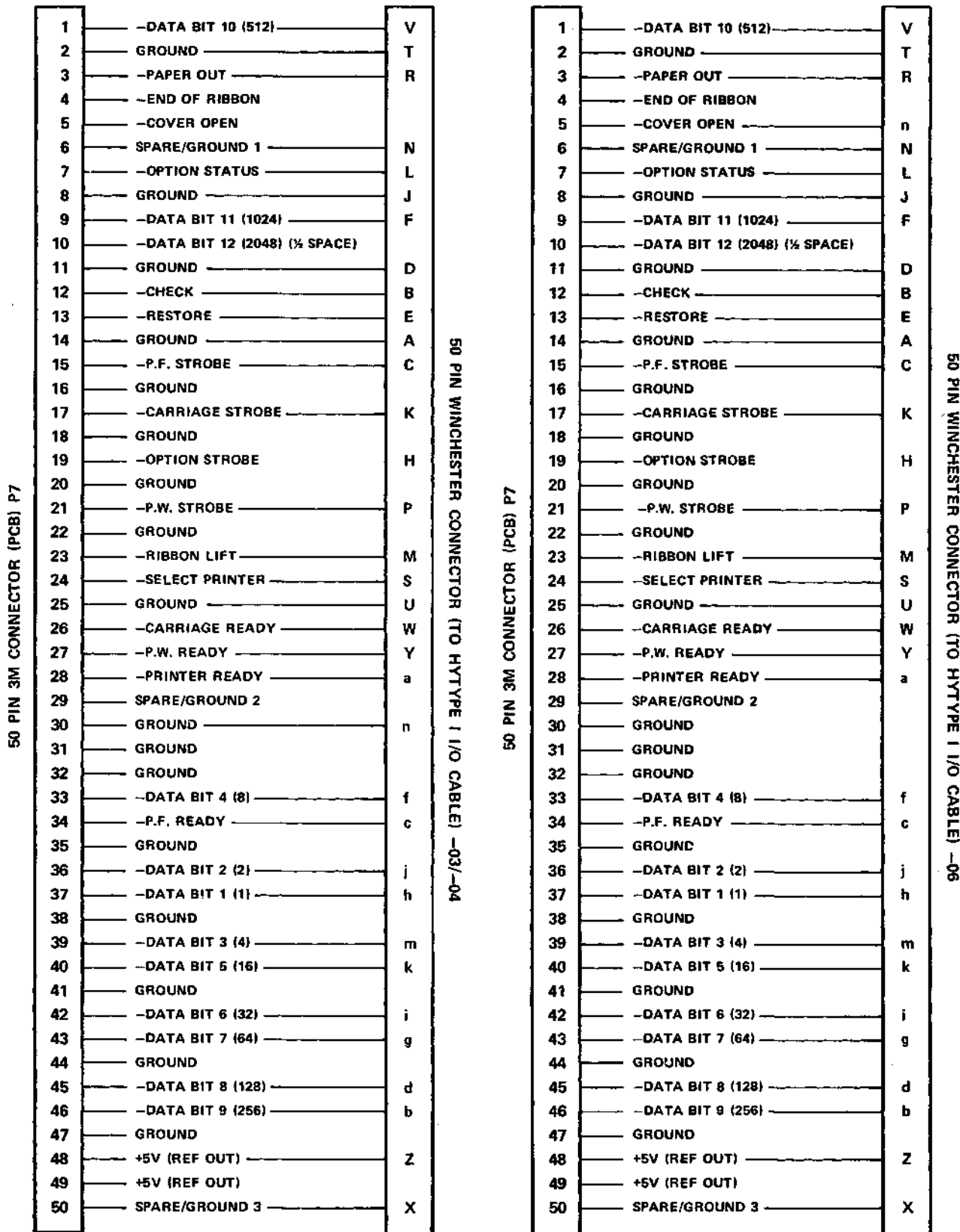

**Figure 2-13 HyTYPE II to HyTYPE I ADAPTER CABLE
MATING PLUG PIN ASSIGNMENT**

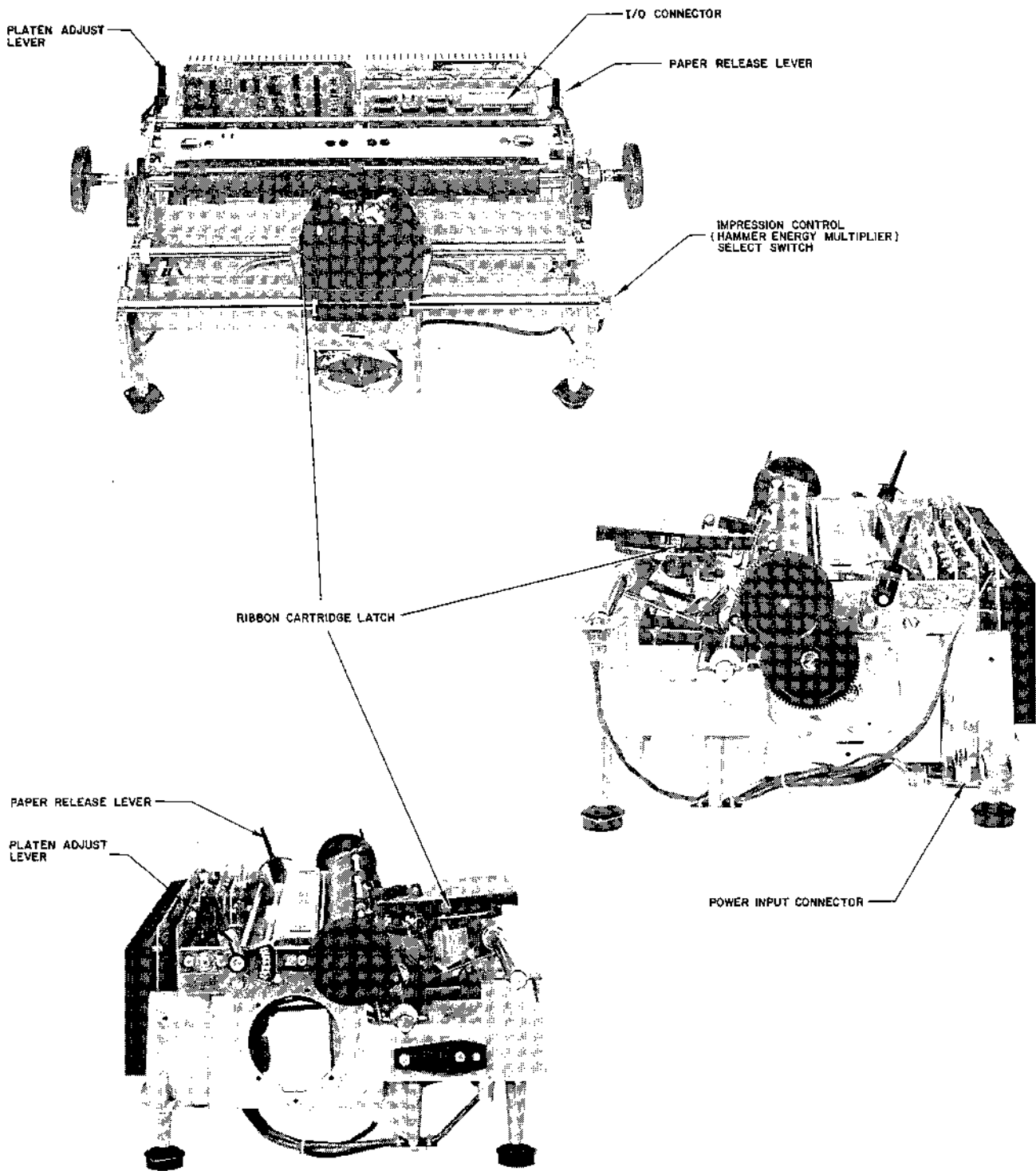

Figure 2-14 HyTYPE II FEATURES

2.3 OPERATION

Refer to Figure 2-14.

2.3.1 General Information

The primary functions to be performed by the operator are loading of paper, adjusting for paper thickness, selecting and installing print wheels, selecting and installing ribbon cartridges, and selecting print hammer intensity.

NOTE: A small percentage of printers may require printer adjustments to obtain optimum print quality after shipment. This is due to uncontrollable handling and shipping conditions after the units have left the factory. Refer to subsection 5.4 for print quality tests and adjustments.

2.3.2 Paper Loading

Loading paper into a HyType II Printer is accomplished in much the same manner as a standard typewriter. Paper is inserted down behind the platen, and the platen rolled by hand to bring the paper around the platen and up in front. The paper bail, when pulled forward, aids the operator in directing the paper back over the top of the platen to the rear. The right-hand paper release lever may be pulled forward to release platen pressure to aid in proper paper alignment. After the paper is positioned, both the paper bail and the paper release lever are returned to their operating positions.

CAUTION: Disable the printer before inserting paper to reduce the chances of personal injury or equipment damage should the carriage move suddenly.

2.3.3 Paper Thickness Adjustment

The operator may position the left-hand platen adjust lever for the type of printing to be performed. This lever should be in the first detent position (fully forward, and then back one notch) for printing on single sheets of paper using cloth ribbons. As the paper thickness increases, as with multiple carbon forms or with heavier papers, the lever is moved one or more detents rearward. Each detent position moves the platen back a distance approximately equal to the thickness of one sheet of 20# bond paper.

The platen position lever MUST be in its first detent position when printing on single sheets of paper using carbon ribbons. If this lever is not fully forward in this situation the likelihood of ribbon breakage is increased.

2.3.4 Ribbon Cartridge Replacement

Replacing a Diablo ribbon cartridge is quick and clean. The cartridge is held on its platform atop the carriage by two latches. Pushing down on these latches releases the ribbon cartridge for removal. Lift it straight UP to clear the ribbon guide posts. Installing a new cartridge involves the following simple steps. Each Diablo Ribbon Cartridge has a small knob on its upper surface for moving the ribbon

manually. Use this knob to make sure the exposed portion of the ribbon is free to move, and is tight and straight. Next hold the cartridge in one hand with the exposed ribbon end toward the platen and lower the cartridge down past the print hammer guide. Engage the exposed ribbon behind the two ribbon guide posts on the rear of the ribbon platform, and push the cartridge ears against the card guide. Check that the exposed ribbon is straight, and is located between the card guide and the print wheel. Push the cartridge down firmly until both latches have snapped into their latched positions. Rock the cartridge on its platform back and forth and observe unobstructed up and down movement of the exposed portion of the ribbon. It should NOT catch on the print wheel "petals".

CAUTION: Disable the printer before replacing the ribbon cartridge to reduce the chances of personal injury or equipment damage should the carriage move suddenly.

2.3.5 Print Wheel Replacement

Replacing a Diablo print wheel is fast and simple. The ribbon cartridge is first removed, as instructed above. The inner carriage assembly then tilts forward away from the platen to expose the print wheel. The print wheel is held on the motor shaft hub by friction, and is easily pulled free by grasping its rubber hub.

Install a print wheel by pushing it on to the print wheel motor shaft hub. Make sure the alignment slot in the wheel is properly aligned with the alignment tab protruding from the shaft hub. Push the wheel firmly and fully onto the shaft hub. Raise the inner carriage assembly back into its operating position, and reinstall the ribbon cartridge.

CAUTION: Disable the printer before removing the ribbon cartridge or replacing the print wheel, to reduce chances of personal injury or equipment damage should the carriage move suddenly.

2.3.6 Print Intensity Adjustment

The printer's Impression Control switch provides three levels, or steps, of print intensity (hammer energy) to accommodate print wheel font variations as well as multiple copy printing.

- 0 (for High) = Used for heavy printing on multiple page forms
- o (for Medium) = Used for most normal work
- . (for Low) = Used for light printing to extend the life of the more delicate light* type fonts.
(* = as compared to Medium- or Bold-type fonts)

SECTION 3

INTERFACE INFORMATION

3.1 GENERAL INFORMATION

The following subsections contain detailed information on interfacing the HyType II Printer with a host controller.

3.2 INPUT/OUTPUT CONSIDERATIONS

3.2.1 Signal Definitions

Definitions of the input and output interface lines are listed in table 2-2. Signal polarity is 0 volt nominal designated as LO (for 1 or true), and +5 volts nominal designated as HI (for 0 or false).

3.2.2 Input Lines

3.2.2.1 SELECT PRINTER Line

This line carries an active LO signal from the controller. The signal interrogates the printer for its status by enabling the printer's five READY outputs. SELECT PRINTER also enables all other interface lines.

3.2.2.2 STROBE Lines

Four lines receive active LO STROBE signals from the controller which are used to initiate activities within the printer. These are Carriage, Paper Feed, Print Wheel, and Option.

3.2.2.3 RESTORE Line

This line carries an active LO signal from the controller which causes the printer to perform a restore sequence. This signal should not be used as a carriage return command.

3.2.2.4 RIBBON LIFT Line

This line carries a signal from the controller which is used to control the print ribbon position. When LO, the ribbon is lifted to its UP position for printing in the primary ribbon color (Diablo standard is black). When HI, the ribbon is left in its DOWN position for printing in the secondary color (of a two-color ribbon), or to provide printed character visibility.

3.2.2.5 DATA Lines

Twelve DATA lines receive binary coded information from the controller. This information is in the form of multiplexed data words where HI=0 and LO=1. These data words represent commands for the several printer operations when accompanied by the proper execute (or strobe) signal. Table 3-1 lists the data line significance during various normal strobe commands.

TABLE 3-1
DATA LINE SIGNIFICANCE DURING VARIOUS STROBE COMMANDS

DATA LINE	DATA BIT	PRINT WHEEL STROBE	CARRIAGE STROBE	PAPER FEED STROBE
1	1	} Print Wheel Position Code	} Carriage Motion – decimal equivalent times 1/60 inch (.423mm)	} Paper Feed Motion – decimal equivalent times 1/48 inch (.529mm)
2	2			
3	4			
4	8			
5	16			
6	32			
7	64			
8	128			
9	256	} used only with jumper options	} Direction * 1/2 Space***	} Direction ** (Not used)****
10	512			
11	1024			
12	2048			

* When HI move carriage RIGHT
 ** When HI move paper UP (forward)
 *** When LO adds additional 1/120 inch (.212mm) movement
 **** Should be forced HI

The several HyType II Printer models differ mainly in the manner in which commands are entered and executed during the Print Wheel Strobe sequence. Each model is provided with three operating options, implemented by inserting selected jumper wires on the Logic I PCB. Table 3-2 lists these jumper wire options, and briefly describes the effect each has on the operation of each model.

TABLE 3-2
OPTION JUMPER SIGNIFICANCE

JUMPER	MODEL 1345A	MODEL 1355HS	MODEL 1355WP
RIB.OPT 1	Force single step ribbon advance for higher speed operation. This option preempts RIB.OPT 2 features.	Force single step ribbon advance for higher speed operation. This option preempts RIB.OPT 2 features.	Increases carriage settling time to improve horizontal registration.
RIB.OPT 2	Enable Data Bit 12 (2048) to control ribbon advance, where DL 12 = LO = 2 step, and DL 12 = HI = 1 step advance	(Not applicable)	Enable direct interface access to ribbon advance, hammer energy, and print wheel position (Absolute Print Wheel Position). This option preempts HAMMER ENERGY features.
HAMMER ENERGY	Enable direct interface access to hammer energy, and controllable direct access to print wheel position (Absolute Print Wheel Position), where DL 8 = HI = ASCII PW pos and DL 8 = LO = Interface PW pos	Enable direct interface access to hammer energy, and controllable direct access to print wheel position (Absolute Print Wheel Position), where DL 8 = HI = ASCII PW pos and DL 8 = LO = Interface PW pos	Enable direct interface access to ribbon advance and hammer energy.

The following subsections detail the data line significance for each model printer, including an expansion of the effect of the jumper wire options.

3.2.2.5.1 Models 1345A and 1355HS

1. Print Wheel, Ribbon Advance and Hammer Energy Commands

Models 1345A and 1355HS

When representing an ASCII character command for the print wheel, the seven low order bits (1 thru 64) are used to designate the next character to be printed according to the Diablo modified 7-bit ASCII code shown in Table 3-3. In this normal mode of operation, the printer's internal logic determines the shortest distance and direction for print wheel movement to bring the commanded character in front of the print hammer as fast as possible. Also, the printer's logic will select a hammer energy level from its ROM table appropriate for the commanded character in a standard type font, and a 2-step ribbon advance.

Model 1345A and 1355HS

When the RIB. OPT 1 option is selected, the printer's internal program is forced to implement one-step ribbon advance only. This has the effect of reducing the overall program cycle time for faster printing. This option preempts RIB. OPT 2.

Model 1345A

When the RIB. OPT 2 option is selected, the controller can make use of Data Line 12 (bit 2048) to command one- or two-step ribbon advance. The RIB. OPT 2 feature is preempted by RIB. OPT 1, since that option forces one-step ribbon advance in all cases. Table 3-2 lists the data line commands for ribbon advance enabled when this option is selected.

Models 1345A and 1355HS

When the HAMMER ENERGY option is selected, the controller can use Data Line 8 (bit 128) to command access to print wheel position, and Data Lines 9 (bit 256), 10 (bit 512), and 11 (bit 1024) to control hammer energy. When this option is selected and Data Line 8 is HI during a Print Wheel Strobe, the print wheel logic will respond normally to ASCII code commands on the 7 low order data lines for print wheel positioning. When Data Line 8 is LO during a Print Wheel Strobe, the print wheel logic will respond to 7-bit Absolute Print Wheel Address codes on these same lines. Table 3-3 also lists the Absolute Print Wheel Address codes used in this mode, and Figure 3-1 illustrates the Print Wheel electrical spoke positions commanded by these codes for a typical Diablo 96 Character Plastic Print Wheel. Table 3-4 lists the interface hammer energy command sequences to be used when this option is selected.

TABLE 3-3
PRINT WHEEL DATA

P.W. ELECTRICAL (CW) SPOKE POSITION	P.W. PHYSICAL (CCW) SPOKE POSITION	P.W. STANDARD PRINT CHARACTER	DIABLO MODIFIED ASCII CODE								ABSOLUTE P.W. ADDRESS CODE****								
			DL	DL	DL	DL	DL	DL	DL	DL	DL	DL	DL	DL	DL	DL	DL	DL	
			7	6	5	4	3	2	1		7	6	5	4	3	2	1		
			64	32	16	8	4	2	1	64	32	16	8	4	2	1			
1	95	␣	LO	LO	LO	LO	LO	LO	LO	HI	HI	HI	HI	HI	HI	LO			
2	94	␣	HI	LO	HI	HI	HI	HI	HI	HI	HI	HI	HI	HI	LO	HI			
3	93	␣	HI	LO	HI	LO	LO	HI	HI	HI	HI	HI	HI	LO	LO				
4	92	W	LO	HI	LO	HI	LO	LO	LO	HI	HI	HI	HI	LO	HI	HI			
5	91	␣	HI	LO	HI	LO	LO	LO	HI	HI	HI	HI	HI	LO	HI	LO			
6	90	M	LO	HI	HI	LO	LO	HI	LO	HI	HI	HI	HI	LO	LO	HI			
7	89	Z	LO	HI	LO	LO	HI	LO	HI	HI	HI	HI	HI	LO	LO	LO			
8	88	B	LO	HI	HI	HI	HI	LO	HI	HI	HI	HI	LO	HI	HI	LO			
9	87	F	LO	HI	HI	HI	LO	LO	HI	HI	HI	HI	LO	HI	HI	LO			
10	86	C	LO	HI	HI	HI	HI	LO	LO	HI	HI	HI	LO	HI	LO	HI			
11	85	A	LO	HI	HI	HI	HI	LO	LO	HI	HI	HI	LO	HI	LO	LO			
12	84	:	HI	LO	LO	LO	HI	LO	HI	HI	HI	HI	LO	LO	HI	HI			
13	83	R	LO	HI	LO	HI	HI	LO	HI	HI	HI	HI	LO	LO	HI	LO			
14	82	S	LO	HI	LO	HI	HI	LO	LO	HI	HI	HI	LO	LO	LO	HI			
15	81	E***	LO	HI	HI	HI	LO	HI	LO	HI	HI	HI	LO	LO	LO	LO			
16	80	T	LO	HI	LO	HI	LO	HI	HI	HI	HI	LO	HI	HI	HI	HI			
17	79	H	LO	HI	HI	LO	HI	HI	HI	HI	LO	HI	HI	HI	LO	HI			
18	78	O	LO	HI	HI	LO	LO	LO	LO	HI	HI	LO	HI	HI	LO	HI			
19	77	N	LO	HI	HI	LO	LO	LO	HI	HI	HI	LO	HI	HI	LO	LO			
20	76	I	LO	HI	HI	LO	HI	HI	LO	HI	HI	LO	HI	LO	HI	HI			
21	75	L	LO	HI	HI	LO	LO	HI	HI	HI	HI	LO	HI	LO	HI	LO			
22	74	D	LO	HI	HI	HI	LO	HI	HI	HI	LO	HI	LO	LO	LO	HI			
23	73	U	LO	HI	LO	HI	LO	HI	LO	HI	HI	LO	HI	LO	LO	HI			
24	72	G	LO	HI	HI	HI	LO	LO	LO	HI	HI	LO	LO	HI	HI	HI			
25	71	Y	LO	HI	LO	LO	HI	LO	LO	HI	LO	LO	LO	HI	HI	LO			
26	70	P	LO	HI	LO	HI	HI	HI	HI	HI	LO	LO	LO	LO	LO	HI			
27	69	Q	LO	HI	LO	HI	HI	LO	HI	HI	LO	LO	LO	LO	LO	LO			
28	68	K	LO	HI	HI	LO	HI	LO	LO	HI	HI	LO	LO	LO	LO	HI			
29	67	J	LO	HI	HI	LO	HI	LO	HI	HI	HI	LO	LO	LO	LO	LO			
30	66	V	LO	HI	LO	HI	LO	LO	HI	HI	LO	LO	LO	LO	LO	HI			
31	65	:	HI	LO	LO	LO	HI	LO	LO	HI	HI	LO	LO	LO	LO	LO			
32	64	X	LO	HI	LO	LO	HI	HI	HI	HI	LO	HI	HI	HI	HI	HI			
33	63	1	HI	LO	LO	HI	HI	HI	LO	HI	LO	HI	HI	HI	HI	LO			
34	62	2	HI	LO	LO	HI	HI	LO	HI	HI	LO	HI	HI	HI	LO	HI			
35	61	3	HI	LO	LO	HI	HI	LO	LO	HI	LO	HI	HI	LO	LO	HI			
36	60	4	HI	LO	LO	HI	LO	HI	HI	LO	LO	HI	LO	LO	LO	HI			
37	59	0	HI	LO	LO	HI	HI	HI	HI	HI	LO	HI	HI	LO	LO	LO			
38	58	5	HI	LO	LO	HI	LO	LO	LO	HI	LO	HI	HI	LO	LO	LO			
39	57	6	HI	LO	LO	HI	LO	LO	HI	HI	LO	HI	HI	LO	LO	LO			
40	56	7	HI	LO	LO	HI	LO	LO	LO	HI	LO	HI	LO	LO	LO	LO			
41	55	8	HI	LO	LO	HI	HI	HI	HI	LO	LO	HI	HI	LO	LO	LO			
42	54	9	HI	LO	LO	HI	HI	LO	LO	HI	LO	HI	HI	LO	LO	LO			
43	53	-	HI	LO	LO	LO	HI	LO	LO	HI	LO	HI	LO	LO	LO	LO			
44	52	\$	HI	LO	LO	HI	LO	LO	LO	HI	LO	LO	LO	LO	LO	LO			
45	51	+	HI	LO	LO	HI	LO	LO	LO	HI	LO	LO	LO	LO	LO	LO			
46	50	#	HI	LO	LO	HI	LO	LO	LO	HI	LO	LO	LO	LO	LO	LO			
47	49	%	HI	LO	LO	HI	LO	LO	LO	HI	LO	LO	LO	LO	LO	LO			
48	48	=	HI	LO	LO	LO	LO	LO	LO	HI	LO	LO	LO	LO	LO	LO			

** These characters require light print hammer energy.
 *** Spoke "15" (E) is designated as the Print Wheel "home" position.
 **** The Absolute Print Wheel Address code refers to the Print Wheel's electrical spoke position.
 The "STANDARD" print characters listed are those found on the Diablo COURIER 72 English language print wheel.

3-4

Rev A (4/79)

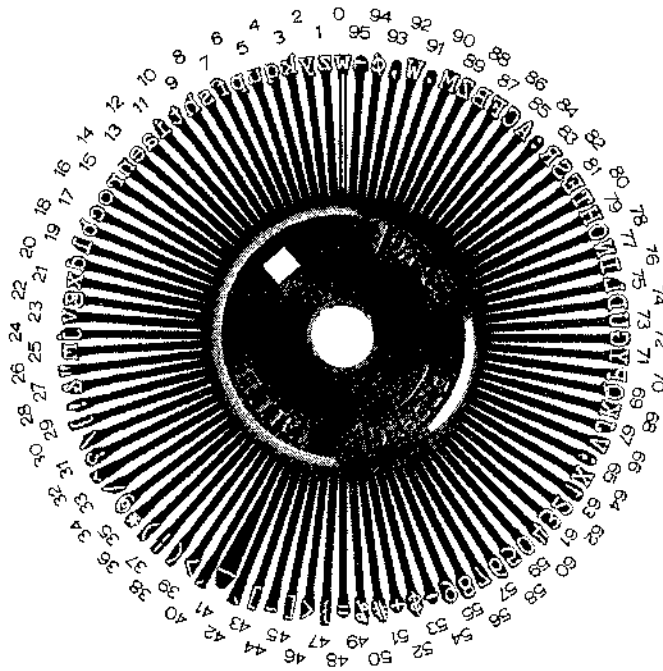

Figure 3-1
96 CHARACTER PLASTIC
PRINT WHEEL PHYSICAL SPOKE POSITION

TABLE 3-4
 HAMMER ENERGY OPTION COMMAND DATA

DL 9	HI	LO	HI	LO	HI	LO	HI	LO
DL 10	HI	HI	LO	LO	HI	HI	LO	LO
DL 11	HI	HI	HI	HI	LO	LO	LO	LO
Level	1	2	3	4	5	6	7	8
	lowest						highest	

2. Carriage Movement Commands

Models 1345A and 1355HS

When receiving a carriage movement command during a carriage strobe sequence, the 10 low order data line bits always represent carriage movement in multiples of 1/60 inch (.423 mm). The printer's internal logic processes the input data bits in even multiples of 1/120 inch (.212 mm), and commands actual carriage movement in increments of 1/120 inch (.212 mm). Users wishing to command carriage movement in terms of 1/120 inch (.212 mm) must do so by first dividing the desired carriage move increment number by 2 and transmitting the result to the printer as multiples of 1/60 inch (.423 mm), and second, to transmit Data Line 12 (bit 2048) = LO whenever the command is for an odd number of 1/120 inch (.212 mm) increments. DL 12=LO commands the printer logic to add one 1/2 space, or 1/120 inch (.212 mm) increment, to the end of the carriage movement. The 11th bit (bit 1024) is used to indicate direction of carriage travel, with a LO directing carriage movement left, and a HI directing carriage movement right. The con-

troller must maintain carriage position and not exceed a total move count of 792 increments of 1/60 inch (.423 mm) right from print position 0.

3. Paper Feed Commands

Models 1345A and 1355HS

When receiving a paper feed command during a Paper Feed Strobe sequence, the 10 low order data line bits represent paper feed movement in multiples of 1/48 inch (.529 mm). The 11th bit (bit 1024) is used to indicate the direction of paper feed movement, with a LO directing paper feed down (reverse), and a HI directing paper feed up (forward). During a paper feed sequence, the 12th or highest order Data Line (bit 2048) is ignored, and should be maintained in the HI state.

3.2.2.5.2 Model 1355WP

1. Print Wheel, Ribbon Advance, and Hammer Energy Commands

The XEROX metalized Word Processor print wheel differs from the standard Diablo plastic print wheel in design, in petal assignment, in number of characters or petals, and in the characters themselves.

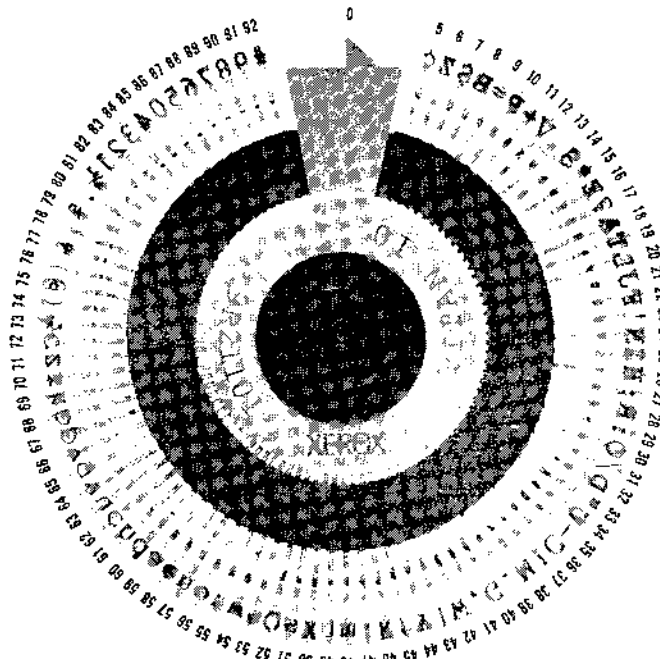

Figure 3-2
XEROX 88 CHARACTER METALIZED
WORD PROCESSOR PRINT WHEEL

Figure 3-2 shows a typical 88 character metalized word processor print wheel.

When representing an ASCII character command for the print wheel, the 7 low order bits (1 thru 64) are used to designate the next character to be printed according to the Diablo modified 7-bit ASCII code shown

in Tables 3-5/-6. In this normal mode of operation, the printer's internal logic determines the shortest distance and direction for print wheel movement to bring the commanded character in front of the print hammer as fast as possible. Also, the printer's logic will select hammer energy levels and ribbon advance increments from its ROM table appropriate for the character being printed.

When the RIB. OPT 1 option is selected, the printer's internal program is changed to increase the carriage settling time from 3 to 8 msec. This additional time improves the horizontal print registration at a small sacrifice in average print speed.

When the RIB. OPT 2 option is selected, all internal programs and tables associated with Print Wheel Strobe are bypassed. The controller is provided direct access to control hammer energy, ribbon advance and print wheel position address. Tables 3-5/-6 include listings of all the data line codes to be used in this mode. Since this mode includes interface access to both ribbon advance and hammer energy, it preempts the HAMMER ENERGY option.

When the HAMMER ENERGY option is selected, in the absence of the RIB. OPT 2 option, interface access to ribbon advance and hammer energy only is enabled. Tables 3-5 and 3-6 list the data line codes to be used in this mode. Note that the print wheel logic will respond to the normal ASCII code in this mode.

2. Carriage Movement Commands

The response of Model 1355WP to carriage movement commands is identical to that of Models 1345A and 1355HS, as outlined in Subsection 3.2.2.5.1.

3. Paper Feed Commands

The response of Model 1355WP to paper feed commands is identical to that of Models 1345A and 1355HS, as outlined in subsection 3.2.2.5.1.

4. Proportional Spaced Printing

When proportionally spaced printing is desired, the user must calculate the Proportional Space Pitch Mode Carriage Advance Unit as follows:

The proportional space pitch mode carriage advance unit is defined as the sum of the PS unit value of the last previously printed character and the PS value of the next character to be printed. The 10-pitch is defined as 12 units, and 12-pitch is defined as 10 units. Table 3-7 lists the character PS units.

The Carriage Advance Unit is then sent to the printer as a carriage movement command, where a carriage advance unit of 1 equals a carriage movement of 1/120 inch (.212 mm). Table 3-8 lists examples of the data line codes necessary to obtain PS carriage advance units of various values.

TABLE 3-7
 CHARACTER PROPORTIONAL SPACE UNITS - WP CARRIAGE ADVANCE

PW POSITION	CHARACTER	PS UNIT	PW POSITION	CHARACTER	PS UNIT	PW POSITION	CHARACTER	PS UNIT	PW POSITION	CHARACTER	PS UNIT
1	()	(3)	25	l	3	49	j	3	73	½	6
2	(~)	(5)	26	H	7	50	X	7	74)	3
3	⅓ (\)	6 (5)	27	;	3	51	s	4	75	@	8
4	£ ({)	5 (3)	28	R	7	52	Q	7	76	(3
5	¢ ()	5	29	:	3	53	t	4	77	&	7
6	Z	6	30	O	7	54	w	7	78	.	3
7	\$	5	31	/	4	55	r	4	79	%	8
8	B	6	32	D	7	56	o	5	80	.	3
9	=	5	33	"	4	57	n	5	81	¼	6
10	P	6	34	U	7	58	e	5	82	1	5
11	+	5	35	-	4	59	a	5	83	2	5
12	V	6	36	C	7	60	d	5	84	3	5
13	_	5	37	!	3	61	h	5	85	4	5
14	S	5	38	M	8	62	c	5	86	0	5
15	*	5	39	.	3	63	u	5	87	5	5
16	E	6	40	G	7	64	v	5	88	6	5
17	?	5	41	,	3	65	g	5	89	7	5
18	A	7	42	W	8	66	y	5	90	8	5
19	T	6	43	l	3	67	p	5	91	9	5
20	L	6	44	Y	7	68	b	5	92	#	6
21	J	5	45	f	4	69	k	5	93	⅓ (})	6 (3)
22	F	6	46	K	7	70	x	5	94	⅔ (~)	6 (5)
23	'	2	47	i	3	71	z	5	95	(\)	(5)
24	N	7	48	m	8	72	q	5	0 (HOME)	{ }	(5)

NOTES:

- Units = 1/120 inch (.212mm) carriage movement.
- Characters and PS unit values listed in this table represent 88-character "Titan 10", 92-character "Titan 10" (UK), and 96-character "Titan 10" print wheels. Parentheses () are used where characters and/or PS units of the 96-character wheel differ from those of the 88 and 92-character wheels. PW POSITION utilization is 5 thru 92 for 88-character wheels, 3 thru 94 for 92-character wheels, and 1 thru 0 for 96-character wheels (see Tables 3-3 and 3-4).

Note that a proportional space (PS) print wheel must be used.

If the user wants to minimize the rate at which ribbon is used, the Proportional Space Pitch Mode Ribbon Advance Unit may be calculated as one-half the carriage advance unit.

TABLE 3-8
PROPORTIONAL SPACE UNITS
CARRIAGE ADVANCE

DL 1	HI	LO	LO	HI	HI	LO	LO	HI	HI	LO
DL 2	HI	HI	HI	LO	LO	LO	LO	HI	HI	HI
DL 3	HI	HI	HI	HI	HI	HI	HI	LO	LO	LO
DL 4	HI	HI	HI	HI	HI	HI	HI	HI	HI	HI
DL 5	HI	HI	HI	HI	HI	HI	HI	HI	HI	HI
DL 6	HI	HI	HI	HI	HI	HI	HI	HI	HI	HI
DL 7	HI	HI	HI	HI	HI	HI	HI	HI	HI	HI
DL 8	HI	HI	HI	HI	HI	HI	HI	HI	HI	HI
DL 9	HI	HI	HI	HI	HI	HI	HI	HI	HI	HI
DL 10	HI	HI	HI	HI	HI	HI	HI	HI	HI	HI
DL 12	LO	HI	LO	HI	LO	HI	LO	HI	LO	HI
Units	1	2	3	4	5	6	7	8	9	10

Units = 1/120 inch (.212mm)

TABLE 3-9
PROPORTIONAL SPACE UNITS
RIBBON ADVANCE

DL 8	HI	LO	HI	LO	HI	LO	HI
DL 9	HI	HI	LO	LO	HI	HI	LO
DL 10	HI	HI	HI	HI	LO	LO	LO
Units	2	3	4	5	6	7	8

This ribbon advance unit is then sent to the printer as a ribbon movement command on Data Lines 8, 9 and 10, as shown in Table 3-9.

Note that the user must have selected either the RIB. OPT 2 or the HAMMER ENERGY options to enable proportionally spaced ribbon advance.

3.2.3 Output Lines

3.2.3.1 READY Lines

Five lines transmit the status of the several operating parts of the printer to the controller, when enabled by the SELECT PRINTER=LO signal. These are Printer, Carriage, Paper Feed, Print Wheel and Option Ready signals. The Printer Ready signal indicates that the printer is receiving proper power input. The others indicate that their associated circuits are in condition to receive and execute commands.

3.2.3.2 CHECK Line

A LO signal on this line indicates that a previously received print wheel or carriage command was not successfully completed, due to a malfunction. This condition stops the printer, and disables the carriage, paper feed and print wheel ready lines. Only a restore sequence, initiated by either controller command or by removal and re-application of power will clear a check condition.

NOTE: The CHECK status line may remain active (LO) for a maximum of 120 nanoseconds after a RESTORE is issued.

3.2.3.3 Paper Out Line (Option)

A LO signal on this line signals an out of paper condition to the controller when this option has been installed in the printer.

3.2.3.4 Cover Open Line (Option)

A LO signal on this line signals the controller that the printer's front access cover is open when this option has been installed in the printer.

3.2.3.5 End Of Ribbon Line (Option)

A LO signal on this line signals the controller that the ribbon cartridge has been depleted, for multistrike carbon film ribbons only, when this option has been installed in the printer.

3.3 TIMING CONSIDERATIONS

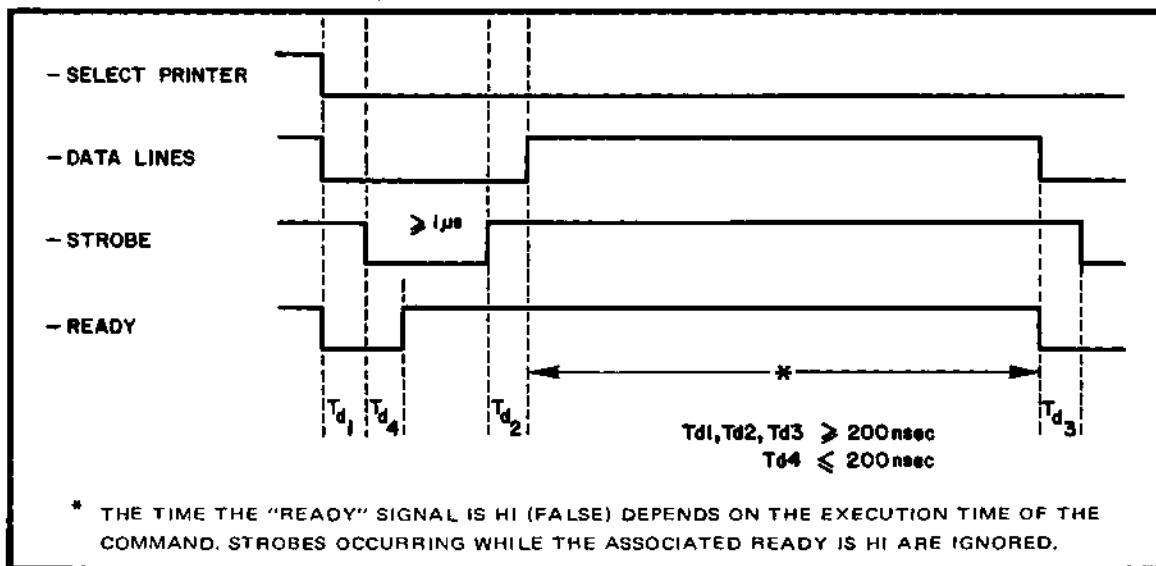

Figure 3-3 TYPICAL COMMAND SEQUENCE

The HyType II Printer will accept data to select a character, move the carriage, or feed paper only when the corresponding STROBE pulse is present on the interface. The timing diagram in Figure 3-3 il-

illustrates the typical timing relationship between the DATA input, the STROBE pulse, and the READY signal. Timing for carriage move commands and paper feed commands are exactly the same. The corresponding READY line must go LO prior to application of the STROBE, or the command will be lost. Note also that a ribbon command will change the PRINT WHEEL READY status.

Strobes for selecting a character (print wheel), moving the carriage, and moving the paper can be received with a minimum separation of 400 nanoseconds between them. Strobes sent to the printer will be executed in the order of receipt. The print wheel, carriage, and paper feed may be moving simultaneously. However, the print wheel will inhibit paper and/or carriage movement during the printing (hammer fire) portion of its cycle.

The print wheel cycle is divided into two subcycles:

1. Motion of the print wheel to the selected character; and
2. Firing of the print hammer.

The firing of the hammer will be executed ONLY when the print wheel, carriage, and paper feed are all at rest. During the hammer fire sub-cycle, any print wheel rotation, carriage movement, or paper feed is deferred until completion of the character print.

A CARRIAGE STROBE followed (400 nsec later) by a PRINT WHEEL STROBE will cause the carriage and the print wheel to move. Printing will occur when both the carriage and the print wheel are fully stopped. This is a space before print sequence. In this case motion is overlapped.

A PRINT WHEEL STROBE followed (400 nsec later) by a CARRIAGE STROBE will cause the print wheel to rotate and the character to be printed prior to the carriage motion. In this case, motion will not be overlapped. This is a space after print sequence. The time involved is not the same for both sequences because of the overlapped motion.

The RIBBON LIFT signal can only be changed when the PRINT WHEEL READY signal is LO. The minimum ribbon lift pulse length is 200 msec, with a maximum cycle time of 5 position changes per second. Refer to subsection 1.3.8 CAUTION note. Note also that RIBBON LIFT and PRINT WHEEL strobes must not coincide.

3.4 INPUT GATES

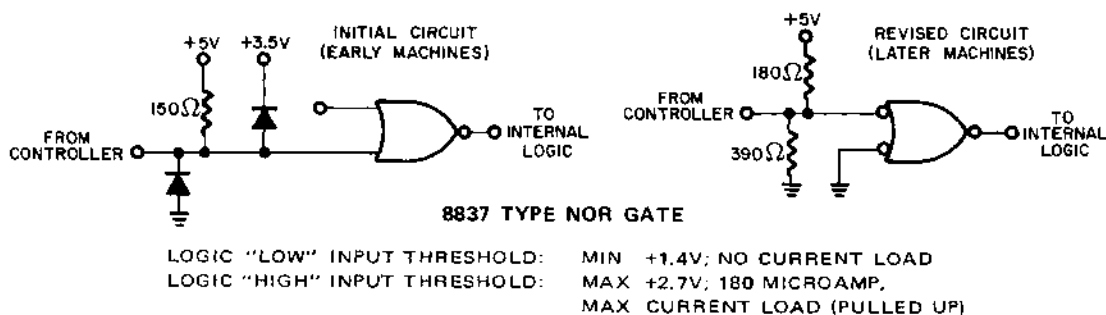
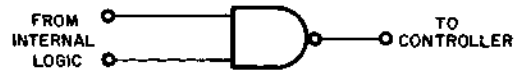

Figure 3-4 STANDARD INPUT CIRCUITS

The input of the printer line receiver must be pulled up to the HI logic state. For this reason it cannot be driven by an open collector driver without collector resistance. The collector resistance inside the printer is 150 Ohms. The circuits are configured as shown in Figure 3-4.

3.5 DRIVE CAPABILITY OF OUTPUT GATES



75452 TYPE TTL POWER GATE

LOGIC "LOW" OUTPUT LEVEL: MAX $-0.5V$ AT 100 MILLIAMP, SINK CURRENT
LOGIC "HIGH" OUTPUT LEVEL: MIN $-4.5V$ AT NO EXTERNAL LOAD CURRENT

Figure 3-5 OUTPUT DRIVER CIRCUIT

The open collector circuit shown in Figure 3-5 is used to drive the output lines to the controller. Collector resistance of 150 Ohms is recommended within the controller.

SECTION 4

PRINCIPLES OF OPERATION

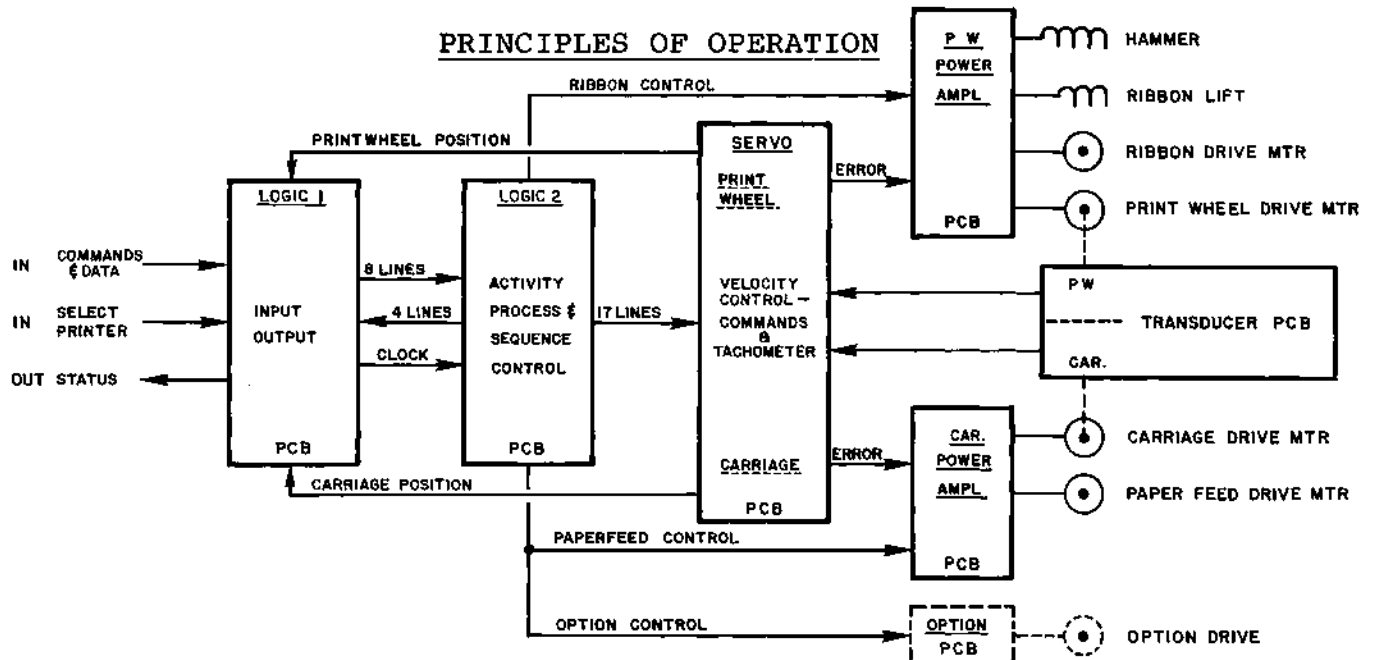

Figure 4-1 HyTYPE II PRINTER BLOCK DIAGRAM

4.1 GENERAL DISCUSSION

Input to the HyType II Printer from the controller consists of 4 individual Strobe lines, 12 common Data lines, a Select Printer line, a Ribbon Lift line, and a Restore line. Output from the HyType II to the controller consists of 5 individual Ready lines, a Check line, and 3 option status lines (Paper Out, End Of Ribbon, and Cover Open). All of these lines channel thru the I/O connector J7 located along the top edge of Logic #1 PCB in the printer's electronic compartment, slot A.

The HyType II Printer uses a microprocessor based logic system where the data portions of the several types of commands are multiplexed together on the 12 common data lines, and share common input and control circuits. The microprocessor continuously circulates command and situation data for each of the several printer functions. It performs an arithmetical update operation for each function on every program pass or cycle, whenever data is present. At the proper time in each program cycle, the processed data is channeled out to the individual drive circuits to activate the function.

While the HyType II Printer was designed to be used alone as the single output device for a computer system, it includes circuit provision to allow the use of more than one printer in a system all receiving commands from a common data bus. This feature is the -SEL PRINTER input. When power is properly applied to the printer, its internal circuits are all reset, and ready to receive commands. Prior to issuing any commands, the controller must first issue a -SEL PRINTER=LO signal to select the printer, and must receive from the selected printer a LO signal on each of the 5 Ready lines to ensure that the printer's systems are ready to receive and execute commands.

Movement commands are accepted from the controller by a selected printer, and stored on Logic #1 PCB, slot A. They are then gated out at the proper time to the microprocessor storage and processing circuits on Logic #2 PCB, slot B. The microprocessor's program then controls the step-by-step handling of all data throughout the circuit.

Processed print wheel and carriage commands go to the Servo PCB, slot C, where, in conjunction with position feedback transducers, positional error signals are generated. These error signals are channeled to the appropriate Power Amplifier PCB's where they become servo drive signals for the print wheel and carriage servo motors. Feedback loops, beginning at the position transducers on each of these motors, introduce continuously updated true position status to the servo circuits and to the microprocessor on Logic #2 PCB through circuits on Logic #1 PCB, for an ongoing comparison of present-to-commanded position. The result of these comparisons are the positional error signals mentioned above.

Processed ribbon commands go directly from Logic #2 PCB to the ribbon drive circuits on the Print Wheel Power Amplifier PCB, slot H. Processed paper feed commands go directly from Logic #2 PCB to the paper feed drive circuits on the Carriage Power Amplifier PCB, slot D. Both of these are one-way instructions which do not rely on position status feedback to the logic circuits for position update.

All printer functions may be in motion except during print hammer fire time. Since the act of imprinting a character mechanically bridges all moving functions, they must all be at rest prior to energizing the print hammer solenoid. A system of firmware interlocks ensures that these preconditions are all met before firing of the print hammer is allowed.

The printer's electronic design includes firmware for resetting and initializing carriage and print wheel servos. This is called RESTORE, a program activated by conditions within the printer, or by command from the controller. The RESTORE operation is divided into two parts:

- # Carriage initialization, and
- # Print Wheel initialization

Carriage initialization is performed first in any RESTORE sequence. The carriage is commanded to move to the left (reverse) at a low velocity. When Carriage Home is detected (a sensor is located under the left end of the front carriage rail where a light beam is interrupted by the arrival of the carriage), the carriage servo is disabled. After .1 second, the carriage is commanded to move to the right (forward). After the microprocessor detects the absence of Carriage Home, it allows the carriage to move two more position increments of 1/120 inch (.212 mm) each, or 1/60 inch (.423 mm), and stops the carriage. This location is designated as the carriage home position.

Print Wheel initialization is performed after the carriage has been initialized. The print wheel is commanded to rotate clockwise at a velocity corresponding to a move of 30 counts (15 character petals). As the print wheel passes the Print Wheel Home position sensor (a vane mounted on the print wheel motor shaft behind the print wheel induces

a voltage pulse in an inductor mounted on the carriage frame each time it passes) for the third time, the microprocessor resets its Absolute Counter to zero. The microprocessor then allows the print wheel to move 30 more counts and then stops it. This position is designated as the print wheel home position, and is the capital E on the standard print wheel furnished with each Model 1345A printer, the lower case w on the standard print wheel furnished with each Model 1355HS printer, and is the "flag" position on the metalized print wheel furnished with each Model 1355WP printer. Note also that the print wheel stops "at the sensor" and does not rotate the additional 15 counts in Models 1355HS and 1355WP to reach the print wheel home position.

The following subsections provide detailed operating descriptions of the printer's logic and drive circuits. See Section 7 for a description of the conventions used in describing the circuits.

NOTE: Schematics for and discussion of earlier versions of each PCB have been dropped from publication. Users who need copies of the old schematics may request them by writing to the address listed in the preface.

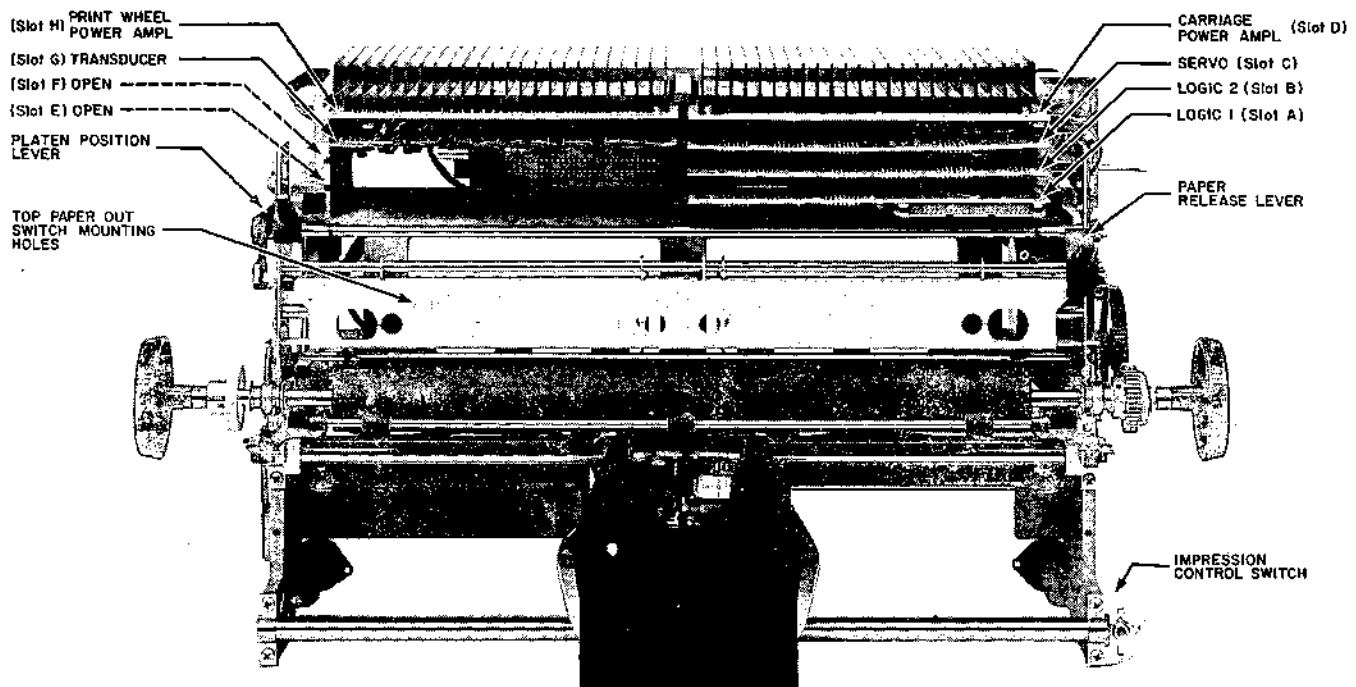

Figure 4-2 COMPONENT LOCATIONS

4.2 MOTHERBOARD PCB CIRCUITS

4.2.1 General Information

The Motherboard PCB for the HyType II Printer is mounted flat laterally across the bottom rear of the printer's main frame. It supports up to eight edge mounted circuit boards which plug into its connectors from above, down through the main frame electronics cavity. The Motherboard PCB also includes a variety of connectors along its edges for

**TABLE 4-1
STANDARD MOTHERBOARD
CONNECTORS AND ASSIGNMENTS**

CONNECTOR	ASSIGNMENT
PCB Edge Connector <i>A</i>	Logic # 1 PCB
PCB Edge Connector <i>B</i>	Logic # 2 PCB
PCB Edge Connector <i>C</i>	Servo PCB
PCB Edge Connector <i>D</i>	Carriage Power Amplifier PCB
PCB Edge Connector <i>E</i>	Empty Slot, available for special purpose PCB
PCB Edge Connector <i>F</i>	Option PCB, Split Platen Drive
PCB Edge Connector <i>G</i>	Transducer PCB
PCB Edge Connector <i>H</i>	Print Wheel Power Amplifier PCB
Jack J1	Power Input
Jack J2	Carriage Home Sensor
Jack J3	Impression Control Switch
Jack J4	Carriage Facilities (PW motor, print hammer, ribbon lift and drive)
Terminal T1	Cover Open Switch Option
Terminal T2	Ground, Cover Open Switch
Terminal T3	Chassis Ground (optional)
Terminal T4	Right Hand Paper Feed Drive
Terminal T5	Right Hand Paper Feed Drive
Terminal T6	Right Hand Paper Feed Drive
Terminal T7	Right Hand Paper Feed Drive
Terminal T8	Ground, Paper Out Switch Option
Terminal T9	Paper Out Switch Option
Terminal T10	Option Drive
Terminal T11	Option Drive
Terminal T12	Option Drive
Terminal T13	Option Drive

NOTE: Earlier machines also included Motherboard connectors J5 and J6, which were used to interconnect the carriage (J5) and print wheel (J6) transducers. Later machines use connectors J8A and J8B mounted on the Transducer PCB.

**TABLE 4-2
8080 MOTHERBOARD
CONNECTORS AND ASSIGNMENTS**

CONNECTOR	ASSIGNMENT
PCB Edge Connector <i>A</i>	Logic # 1 PCB
PCB Edge Connector <i>B</i>	Logic # 2 PCB
PCB Edge Connector <i>C</i>	Servo PCB
PCB Edge Connector <i>D</i>	Carriage Power Amplifier PCB
PCB Edge Connector <i>E</i>	8080 Processor PCB
PCB Edge Connector <i>F</i>	Option PCB, Split Platen Drive
PCB Edge Connector <i>G</i>	Transducer PCB
PCB Edge Connector <i>H</i>	Print Wheel Power Amplifier PCB
Jack J1	Power Input
Jack J2	Carriage Home Sensor
Jack J3	Impression Control Switch
Jack J4	Carriage Facilities (PW motor, print hammer, ribbon lift and drive)
Terminal T1	Cover Open Switch Option
Terminal T2	Ground, Cover Open Switch
Terminal T3	Ground (optional)
Terminal T4	Right Hand Paper Feed Drive
Terminal T5	Right Hand Paper Feed Drive
Terminal T6	Right Hand Paper Feed Drive
Terminal T7	Right Hand Paper Feed Drive
Terminal T8	Ground, Paper Out Switch
Terminal T9	Paper Out Switch Option
Terminal T10	Option Drive
Terminal T11	Option Drive
Terminal T12	Option Drive
Terminal T13	Option Drive

interconnecting to remote items such as drive motors and switches. The board extends to the right, out beyond the side of the main frame, to receive the printer's input power through either a plug-in connector (J1) or several spade lug terminals (T11 - T15). Its circuits provide interconnection between the several PCB's mounted on it, along with circuits for power distribution.

Current applications for the HyType II Printer require a variety of motherboard circuits. The following subsections discuss these circuits individually.

4.2.2 Standard Motherboard PCB, #40500-XX

Refer to Figure 7-1a, Schematic Diagram.

This Motherboard circuit is designed to accommodate all models of the HyType II Printer except the specialized Systems and 8080 type interfaces. It includes circuits to support all currently available options and has one empty PCB edge connector location (Slot E) which users may utilize for mounting special circuit boards of their own design. Slot F has a connector mounted in place, and carries control interties to the Logic #2 PCB connector and to Terminals T10-T13. This Option facility will support the circuit board for the optional Split Platen Drive system.

Figure 7-1a includes a layout drawing for this circuit board which locates and identifies its several connectors and terminals. Table 4-1 below lists these and establishes the circuit assignment for each.

4.2.3 8080 Interface Motherboard PCB, #40614-04

Refer to Figure 7-1b, Schematic Diagram.

This Motherboard circuit is designed to accommodate those HyType II models which make use of the 8080 type interface. The Option drive assignment of Slot F is retained, while a connector mounted in Slot E mounts an 8080 Processor PCB.

Figure 7-1b includes a layout drawing for this circuit board which locates and identifies its several connectors and terminals. Table 4-2 below lists these and establishes the circuit assignment of each.

4.2.4 System Interface Motherboard PCB, #46080-01

Refer to Figure 7-1c, Schematic Diagram.

This Motherboard circuit is designed to accommodate those HyType II models destined to be incorporated into systems which will not make use of the Split Platen option. In this instance, the 8080 Processor PCB remains in Slot E, while Slot F is vacated and left open. The PCB circuits connect all Slot E connector pads in parallel with Slot F pads. In addition, power input connector J1 is deleted and replaced with spade lugs, and the right-hand end mounting bracket is redesigned to eliminate the adapter cable mounting feature.

Figure 7-1c includes a layout drawing for this circuit board which locates and identifies its several connectors and terminals. Table 4-3 below lists these and establishes the circuit assignment of each.

**TABLE 4-3
SYSTEMS MOTHERBOARD
CONNECTORS AND ASSIGNMENTS**

CONNECTOR	ASSIGNMENT
PCB Edge Connector A	Logic # 1 PCB
PCB Edge Connector B	Logic # 2 PCB
PCB Edge Connector C	Servo PCB
PCB Edge Connector D	Carriage Power Amplifier PCB
PCB Edge Connector E	8080 Processor PCB
PCB Edge Connector F	Empty Slot – Unused
PCB Edge Connector G	Transducer PCB
PCB Edge Connector H	Print Wheel Power Amplifier PCB
Jack J1	Unused – No Connector
Jack J2	Carriage Home Sensor
Jack J3	Impression Control Switch
Jack J4	Carriage Facilities (PW motor, print hammer, ribbon lift and drive)
Terminal T1	Cover Open Switch Option
Terminal T2	Ground, Cover Open Switch
Terminal T3	Ground (Optional)
Terminal T4	Right Hand Paper Feed Drive
Terminal T5	Right Hand Paper Feed Drive
Terminal T6	Right Hand Paper Feed Drive
Terminal T7	Right Hand Paper Feed Drive
Terminal T8	Ground, Paper Out Switch
Terminal T9	Paper Out Switch Option
Terminal T10	Unused – No Connector
Terminal T11	Input Power, – 15V
Terminal T12	Input Power, + 15V
Terminal T13	Input Power, Analog Ground
Terminal T14	Input Power, Signal Ground and Driver Return
Terminal T15	Input Power, +5V

4.3 LOGIC #1 PCB CIRCUITS

4.3.1 General Information

Refer to Figure 4-3 Block Diagram.

Logic #1 PCB is the interface between the printer's microprocessor and the host controller. It channels commands to the microprocessor and printer status signals to the controller. It routes print wheel and carriage servo position feedback to the microprocessor to update these activities, and it contains the main system clock.

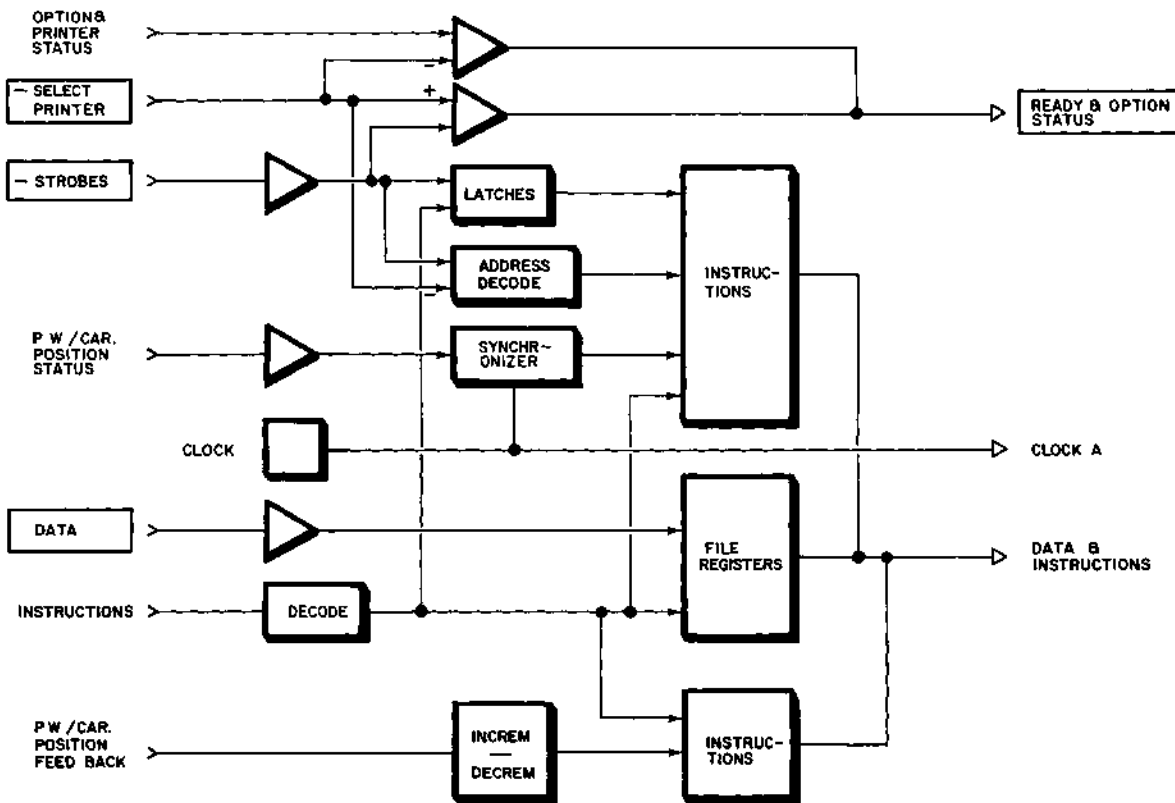

Figure 4-3 LOGIC #1 BLOCK DIAGRAM

Logic #1 PCB currently appears in three major forms, each suited to specific classes of application. In general, the circuits on these PCB's operate as follows.

4.3.1.1 Initialization and Start-Up

When power has been properly applied to the printer, the microprocessor circuits on Logic #2 PCB initiate a restore sequence. As a part

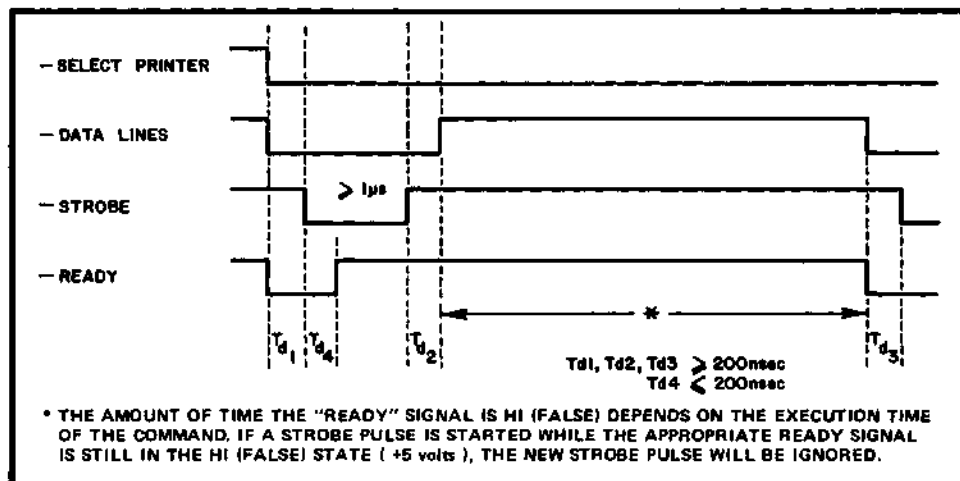

Figure 4-4 TYPICAL COMMAND SEQUENCE

of its overall effect on printer logic, the restore sequence resets all the control flip flops on Logic #1 PCB. When this has been done, the printer is basically ready to accept commands.

Refer to Figure 4-4.

The printer will receive but not accept, store or process commands until it has been selected by the controller. A -SELECT PRINTER=LO signal to a powered up and ready printer will enable several gates. These enabled gates then release several printer status signals to the controller, and prepare the activity strobe circuits to process strobe signals.

4.3.1.2 Command Entry

The controller places LO (true) signals of 1.4 usec minimum duration on the appropriate data lines, followed .2 usec later by a LO (true) signal of 1 usec duration on the appropriate strobe line. The data line signals then pass through line receivers and are presented to the Data Register Files as unaddressed and unprocessed data.

If the printer is ready, and is not in a check condition or a restore cycle, the strobe signal will do three things: One, it will latch the strobe circuits to prevent further strobes from entering; Two, it will drive its associated ready output HI (false); and Three, it will provide an address to the Data Register Files for the data on file.

Later in its program, when the microprocessor circuit on Logic #2 PCB has removed the data from the register files, it issues a reset signal back to the control logic reset circuit on Logic #1 PCB. This signal resets the strobe latch and associated circuits, and the affected ready line goes LO again. This notifies the controller that the next command can be received.

4.3.1.3 Operating Control Logic

1. Restore and Check

The restore sequence is used to initialize the printer, where the carriage and print wheel are moved to their home positions while logic circuits are reset and program counters are restarted at zero. The restore sequence can be initiated from within the printer by the power monitoring circuit, or by command from the controller. During the time the sequence is in process, the strobe latch circuits are disabled, and the printer's ready status lines are all driven HI. They return to the LO state, the strobe latches are again enabled, and the printer is again able to receive and process commands at the completion of the sequence.

The check sequence originates wholly within the printer, and indicates a failure condition where the printer was unable to complete a command. The check signal, like the restore sequence, drives the ready lines HI, disables the strobe latch circuits, and sends a check status signal to the controller. The check condition is usually cleared by a controller issued restore command, but a power off-on cycle may also be used to

initiate the restore sequence to clear the check condition.

2. Ribbon Lift

Ribbon lift commands, issued by the controller serve two functions. The command first controls ribbon position, and second disables the print wheel ready status (drives it HI) for an appropriate length of time following each ribbon position change to allow for mechanical settling.

3. Carriage and Print Wheel Feedback

Two types of feedback signals are required by the microprocessor in order to properly control both carriage and print wheel servo motor movement. One type, servo status, aids in controlling servo position. The other, position feedback, aids in controlling servo speed.

4. Miscellaneous Circuits

During an input read operation, the microprocessor on Logic #2 PCB addresses the Data Register Files and Line Drivers on Logic #1 PCB to release stored input data and other types of instruction information, including;

- * Release of the possible 12-bits of command data in two parts to accommodate the microprocessor's 8-bit wide data input bus.
- * Release of input data address.
- * Release of operating instructions for printing relative to other commands, such as carriage or paper movement.
- * Release of selected operating option commands.

4.3.2 LOGIC #1 PCB Assy, Std., #40505-09

This version of Logic #1 PCB applies to standard Models 1345A and 1355WP HyType II Printers. Refer to Figure 7-2a, Schematic Diagram.

4.3.2.1 Initialization and Start-Up

During the restore sequence following application of power to the printer, the Logic #2 microprocessor issues a series of binary coded commands to CONTROL LOGIC RESET Decimal Decoder F37. F37 then issues clear signals to RESTORE FF G13-5, strobe latch FF's F49-3/F49-5/G49-3 G49-5, RIBBON CHANGE FF's A37-5/A37-13, carriage decrement FF G13-9, and a preset signal to print wheel increment-decrement FF's A25-5 and A25-9. These actions ready the circuits for operation.

The printer can accept commands, however, only after it has been selected. This is done by the controller placing a LO signal on the -SELECT PRINTER input line. -SELECT PRINTER=LO inverts to a HI in passing through its line receiver B61-12/C61-14 to enable gates B37-3, B49-5, B49-3, C49-5, and C49-3. Enabled gates B49-5/-3 and C49-5/-3 release End Of Ribbon, Printer Ready, Paper Out, and Cover Open status signals to the interface. Enabled gate B37-3 combines with the Not In Restore status (RESTORE FF G13-5=LO/-6=HI) to enable gates D37-8 and B37-6. The Not In Check status (CHECK=LO) input through enabled gate D37-8 and inverter F13-4 establishes a HI at gate B37-6

which is +(-CHECK·_RESTORE·+PRINTER READY·+SELECT PRINTER). The signal D37-8=LO is also supplied to gate B45-5 where the signal -CHECK=HI is generated and supplied to the interface as a Not in Check, Not In Restore status signal to the controller.

Gate B37-6=HI enables three READY gates - C45-3 (-CARRIAGE READY), D49-3 (-PAPER FEED READY), B45-3 (-OPTION READY), and gate B37-8. This gate is enabled anytime after a programmed 160 msec delay for settling which follows any Ribbon Lift command. If enabled, B37-8 will pass the B37-6=HI to enabled C45-5 (-PRINT WHEEL READY). These four ready signals are also supplied to the interface as status of printer signals to the controller. With the printer selected and the appropriate READY lines LO (true), the printer can accept commands from the controller.

4.3.2.2 Command Entry

The controller places LO (true) signals of 1.4 usec minimum duration on the appropriate data lines, followed .2 usec later by a LO (true) signal of 1 usec minimum duration on the appropriate strobe line.

The LO data bits pass through their inverting line receivers as HI signals, and are presented to the Data Register Files E73, F73, and D73 as unaddressed and unprocessed data.

If the -SELECT PRINTER input is LO, and the printer is not in check or in a restore cycle, the output of gate B37-6 will be HI. B37-6=HI is presented to gate D37-6. In the absence of a latched strobe signal, D37-6 will be enabled, and its output will clear FF C13-5.

The output of gate D13-3 is normally LO. This LO, seen through FF C13-5 and gates D13-6 and D13-81 maintains a LO on the clock inputs of the STROBE LATCH FF's F49-3/-5 and G49-3/-5. The appearance of a LO signal on any one of the four strobe inputs produces a HI at gate D13-3 and the D input of FF C13-5. This strobe LO also propagates thru gates C37-3/-11 and C37-8, amplifiers F13-14/-12, to the D input of FF F61-10 as a HI. With the next positive excursion of the +CLOCK A signal, this HI will pass through FF F61-10 to clock FF C13-5 to gate D13-6. With the second positive excursion of the +CLOCK A signal, the output of D13-6 will go LO, to drive the output of gate D13-8 HI. This HI will clock the STROBE LATCH FF's. The circuit thus acts as a digital filter, effectively blocking any strobe line signals less than 1 usec in length. At the end of the clock, the STROBE LATCH FF with the active HI on its J input will see its Q output go HI and its -Q output go LO as the FF is clocked. The -Q outputs of the STROBE LATCH FF's go to ready gates C45-3/-5, D49-3 and B45-3, where the appropriate READY line is driven HI as a busy signal to the controller, and to gates E49-3/-6/-8 and -11. The -Q outputs from the Paper Feed and Option STROBE LATCH FF's also go through gate D49-5 to clock CYCLE DATA LATCH FF G37-5. The Q outputs of the STROBE LATCH FF's go to Line Drivers G61 and E61 as address instructions for the micro-processor. The Q output from the Print Wheel STROBE LATCH FF also goes to the D inputs of CYCLE DATA LATCH FF's G37-9 and G37-5. The Carriage STROBE LATCH FF's Q output clocks CYCLE DATA LATCH FF G37-9. The two CYCLE DATA LATCH FF's then produce the +PBH (print before horizontal) and +PBV (print before vertical) instructions for trans-

mittal to the microprocessor. The LO from gate D13-6 during the strobe latch time is also directed to the Data Transfer Files as a -WR=LO write signal to load the data waiting on the data lines according to the address supplied by the Data Address Decode Network.

The +STROBE output from the active Strobe Line Receiver is applied to gates C37-3 and C37-6. The output of these two gates is sent as +PW/CAR STB and/or +PW/OPT STB to the Data Register Files to supply an address for the data being received in conjunction with the strobe, where inputs from the gates are decoded as an address for data as follows:

C37-3 =	LO	HI	HI	LO
C37-6 =	LO	HI	LO	HI
Address =	PF	PW	CAR.	OPT

4.3.2.3 Operating Control Logic

1. Restore and Check

A restore command is received either as a -RESTORE=LO signal from the controller, or as a command from the Logic #2 microprocessor. The microprocessor command will place a LO clear pulse on RESTORE FF G13-5, while the -RESTORE=LO signal will invert through Line Receiver B61-6/D61-12 to clock the FF. Either action will cause FF G13-5 to switch over, producing +RESTORE FF=HI from its Q output, and place a LO on pin 2 of gate B37-3.

If this is a controller command, the +RESTORE FF=HI signal will proceed through Line Driver G61 to the microprocessor on Logic #2 to put the microprocessor into the restore sequence.

In any case, the -Q=LO to gate B37-3 disables the strobe logic and drives all the ready gates HI. This disables the printer until the microprocessor has completed the restore sequence and clears FF G13-5.

A check condition occurs whenever printer systems are unable to complete a carriage or print wheel command. When this occurs, the microprocessor is forced into a program hold situation and issues a +CHECK=HI signal. This HI disables gate D37-8, which in turn disables the strobe logic and drives all the ready gates HI to disable the printer. In addition, a -CHECK=LO signal is sent to the controller to indicate the presence of the check condition. A check condition requires a restart of the microprocessor's programmer to clear. As mentioned before, the restore sequence is the only means of doing this. Restore is initiated here usually by controller command, but can be started by cycling printer power input.

2. Ribbon Lift

Ribbon lift commands enter through a line receiver, and are applied to Ribbon Lift FF's A37-5 and -13. A37-5 is triggered for lift, while A37-13 is triggered for lower commands. Either one being clocked produces an B37-11=LO signal which through gate B37-8 disables the PW READY gate C45-5. The

Ready gate will be disabled for approximately 100 msec, to allow ample time for mechanical settling, and for the microprocessor to note the desired ribbon position.

The command is also sent, as +RIBBON LIFT=HI, through Line Driver G61 to the microprocessor on Logic #2 PCB for execution.

3. Carriage and Print Wheel Feedback

(a) Carriage and Print Wheel Status Synchronizers

Four status signals, CAR EVEN, PW EVEN, CAR HOME, and PW HOME, are required by the microprocessor to help maintain its record of carriage and print wheel position. The microprocessor's operation is timed by the main system clock, and since these four signals are random in nature, they must be synchronized with the clock to be useful to the microprocessor.

FF's F61-5, -7, -12 and -15 are used to generate the clock synchronized Q outputs for each of the four input signals. These are then supplied to the microprocessor through Line Driver E61.

(b) Carriage Difference Counter Decrement Command Generator

When a carriage movement command is received, the microprocessor establishes a value in its carriage difference counter equal to the number of increments the carriage must move to reach the new command location, and also feeds the position data to the carriage servo circuit where the newly generated positional error signal is used to develop the carriage motor drive power.

As the carriage drive motor moves in response to this error signal, its shaft position transducer produces a set of phase modulated RF signals which are fed to the Transducer PCB.

The Transducer's circuits process these inputs and generate a series of triangular wave position signals which are sent to the Servo PCB. Three signals called CAR EVEN, CAR POS A and CAR POS B are derived from these by the Servo circuits and supplied to Logic #1 PCB as inputs to the Carriage Difference Counter Decrement Command Generator circuit. This circuit uses these inputs, as outlined below, to generate a series of pulses fed back to the microprocessor. One pulse is generated each time the carriage has moved one increment of 1/120 inch (.212 mm), and this pulse decrements the microprocessor's Carriage Difference Software Counter one count.

Refer to Figure 4-5. The CAR. EVEN input originates in the Carriage Servo Tachometer circuit. It consists of a series of square-wave pulses where the line level rises to its positive value and remains there as long as a carriage transducer signal called POS SIG #3 is negative. The line level

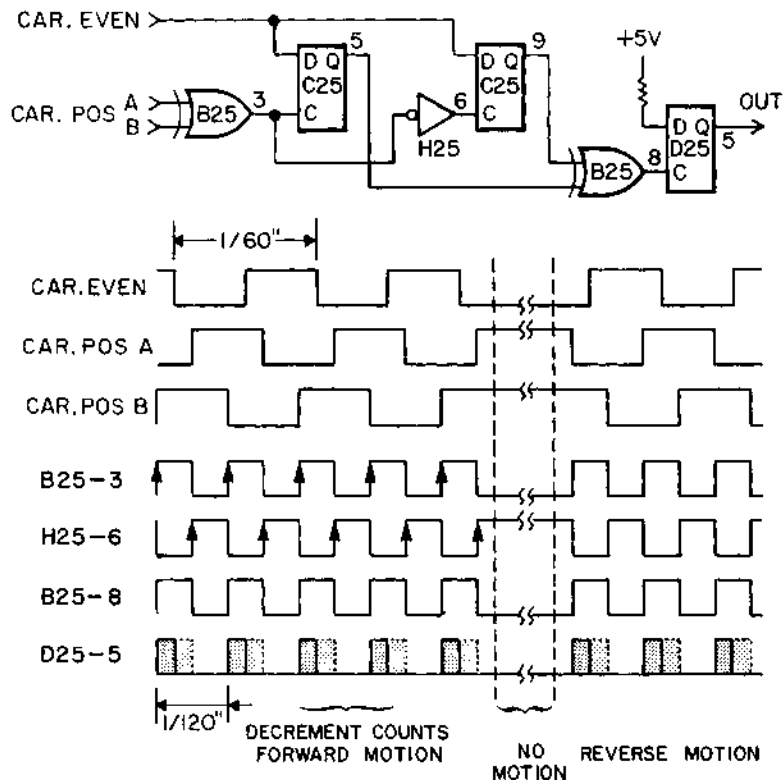

Figure 4-5 CARRIAGE DIFFERENCE COUNTER DECREMENT DRIVE

then falls to zero when POS SIG #3 swings positive. This signal can then be used to mark those points when the carriage position is even. This is the data fed into the FF's F25-5 and F25-9, where each change in input line level represents that point in time where POS SIG #3 experiences a transition through zero. The CAR. POS A and CAR. POS B inputs to Exclusive OR gate G25-3 also originate in the carriage servo tachometer circuit. Their combined output from G25-3 alternately clocks the two FF's. When this clocking occurs following a POS SIG #3 transition, a HI is generated out of FF G13-9 to decrement the counter in the microprocessor.

The clear input of FF G13-9 is called -RST CAR. X. This is a signal sent from the microprocessor to acknowledge receipt of the decrement count and to reset FF G13-9 in preparation for the next count. This signal is also sent during the restore sequence.

NOTE: The reader should also be familiar with the information given in subsection 4.6 SERVO PCB on the operation of the Carriage Position Tachometer circuit, to more fully understand the inputs to this circuit.

(c) Print Wheel Absolute Counter Increment-Decrement Command Generator

This circuit consists of FF's A25, E25, D25, dual AND-OR inverter C25, inverters E13-2 and -4, and gates B25-3/-6/-8 and -11. The inputs to this circuit are exactly the same as the carriage circuit discussed above, being PW EVEN, PW POS A, PW POS B, and -RST PW X. The inputs perform the same functions in this circuit as their counterparts in the carriage circuit.

The difference between the two circuits is that where the carriage circuit's purpose is to decrement its Difference Counter only, the Print Wheel circuit must increment as well as decrement its Absolute Counter due to the independent bidirectional nature of print wheel rotation in executing commands. This circuit thus appears as a dual inverted command generator, when compared to the carriage circuit. The POS A and POS B inputs supply clock, data and clear inputs to the four flip flops. Their inverted forms are also exclusive OR'd by gate G25-6 to provide clock inputs to FF's A25-5 and -9. The Q outputs of FF's D25 and E25 are compared with the PW EVEN signal in the C25 dual AND-OR inverter modules. The outputs of these devices, along with the Q outputs of FF's A25, propagate through a gate network of B25-3/-6/-8 and -11 to be coupled back as the D inputs to FF's A25. This network acts to prevent extraneous signals from being entered as print wheel movement counts. The -Q outputs of FF's A25-5/-9 are sent to the microprocessor's Print Wheel Software Absolute Counter, where two pulses are equal to one print wheel petal (position) movement.

The preset input to FF's A25 is called -RST PW X. This is a signal sent from the microprocessor to acknowledge receipt of the previous count, and to preset the FF's in preparation for the next count. This signal is also sent during the restore sequence.

4. Miscellaneous Circuits

Decimal Decoder modules E37 and F37 provide a means for the microprocessor to address the Data File Registers E73, F73 and D73, and Line Drivers G73, G61 and E61 by encoding input lines 15 through 18, -ENABLE INP, and -RST.

Through multiplexed binary coding of these inputs, a LO signal can be placed on any one of the several outputs. Examination of the circuits will reveal a capability to selectively clear the control logic flip flops, or address functions in the output modules. The -GR LO and -GR HI lines allow the microprocessor to read the 12-bit wide data input word into its 8-bit wide data input bus in two passes. The first pass sees -GR HI=LO enable the high order 4-bits in Register F73. The second pass sees -GR LO=LO enable the low order 8-bits in Registers E73 and D73. The -GATE CMD and -GATE STATUS lines applied to the Line Drivers G73, G61 and E61 control the input, storage and transmittal of the command inputs sent to the Drivers. -GATE JUMPER allows the microprocessor to read the status of the option jumpers. The significance of these jumpers is outlined in Section 3.

4.3.3 Logic #1 PCB Assy, 8080, #40644-05

This version of Logic #1 PCB applies to those standard Model 1345A HyType II Printers which utilize the 8080 type interface. Refer to Figure 7-2b, Schematic Diagram.

This circuit is designed to interface with an 8080 Microprocessor Unit (MPU) instead of a controller. As a result, the manner of data, command and status interchange is different. Inputs to the 8080 Logic #1 PCB are 8 Data Lines (0 through 7), 3 Port Lines (5,6 and 7), a System Clock line, a Read line, a Select Printer line, and a Write line. Output to the 8080 MPU consists of 3 Busy Status lines.

4.3.3.1 Initialization and Start-Up

During the restore sequence following application of power to the printer, the Logic #2 microprocessor issues a series of binary coded commands to CONTROL LOGIC RESET Decimal Decoder E73. E73 then issues clear signals to RESTORE FF D61-5, Strobe Latch FF's B73-3/B73-5/C73-3/C73-5, Carriage Decrement FF E73-6, and a preset signal to the Print Wheel Increment-Decrement FF's D13-5/-9. These actions ready the circuits for operation.

The printer cannot accept commands, however, until it has been selected. This is done by the host system placing a LO signal on the -SELECT PRINTER input line. -SELECT PRINTER=LO inverts to a HI through inverter D37-6 and passes to gate C61-11. If the printer is not in a restore sequence, the -Q output of RESTORE FF D61-5 will enable gate C61-11. If the printer is not in a check condition, the signal from C61-11 will pass enabled gate C61-8 as a LO and on through inverter B61-8 to gate C61-6. C61-6, receiving HI's from both B61-8 and C61-11 will pass a HI to enable all the Busy gates C49-3/-6/-8 and -11, and to Multiplexer module B49, pin 3. The cleared condition of all the Strobe Latch FF's places HI's on the Busy gates to pass " " BUSY=HI signals to the host system signaling all systems are not busy. These HI's, plus the HI from gate C61-8 are placed in Multiplexer module B49, where they will be passed to the Logic #2 microprocessor as instructions. With the printer selected and the BUSY lines HI (false), the printer can accept commands.

4.3.3.2 Command Entry

Ports 5, 6 and 7 are used to transfer data and control/status information between the 8080 MPU and the Logic #2 microprocessor. The 8080 MPU also contains logic that receives and temporarily stores carriage and print wheel position feedback signals from the SERVO PCB, and supplies this data to the Logic #2 microprocessor when requested. Other circuits provide option jumper status to the Logic #2 microprocessor, and develop the CLOCK A signal used by printer logic.

When the 8080 MPU performs an output instruction to Port 5, 6 or 7, the output information is stored on the Logic #1 PCB, where it is available to the Logic #2 microprocessor. Logic #2 periodically reads the Logic #1 storage registers to see if there is any information that it should process. Similarly, as the Logic #2 microprocessor steps through its program, it provides status information to the BUSY line

circuits on Logic #1 PCB. This status is monitored by the 8080 MPU prior to each command output.

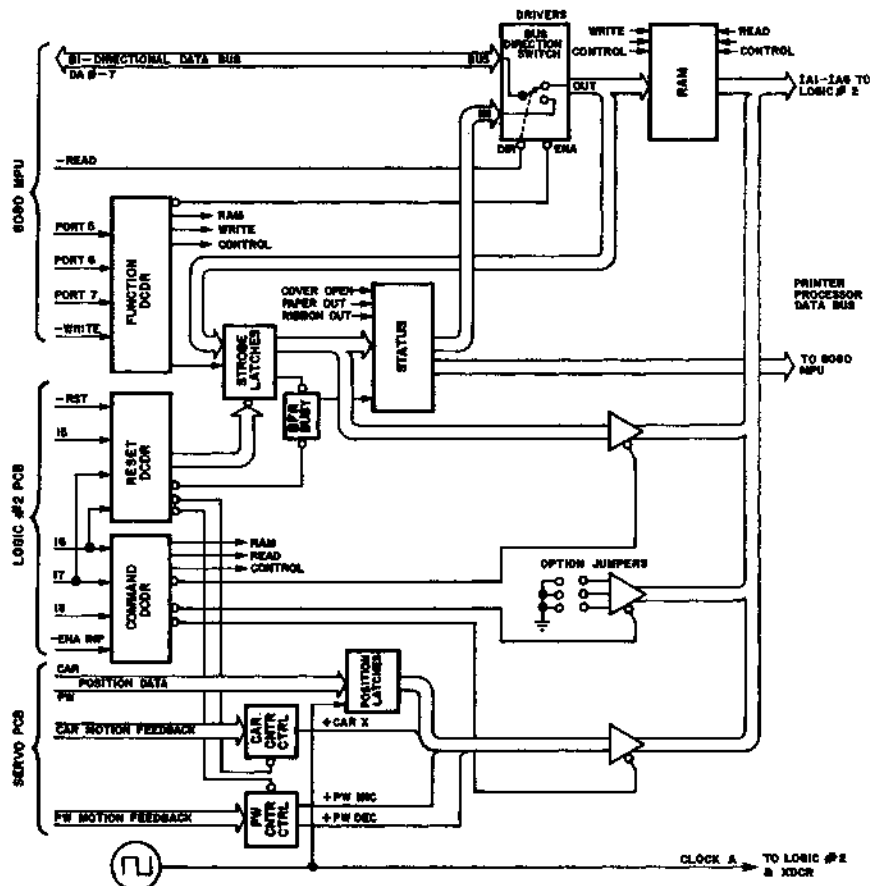

Figure 4-6 8080 LOGIC #1 BLOCK DIAGRAM

Refer to Figure 4-6. The transfer of a printer command from the 8080 MPU to the Logic #2 microprocessor involves the following steps:

1. 8080 MPU writes low order 8-bits to Port 6 (stored in RAM)
2. 8080 MPU writes high order bits and direction bit to Port 7 (also stored in RAM)
3. 8080 MPU writes control word containing strobe bit to Port 5 (stored in STROBE LATCHES), and sets BUFFER BUSY FF
4. Logic #2 microprocessor reads STROBE LATCHES to determine nature of the command
5. Logic #2 microprocessor reads high order bits and direction bit from RAM
6. Logic #2 microprocessor reads low order 8-bits from RAM, and resets BUFFER BUSY FF

(a) Write to Ports 6 and 7

When a write command is executed to either Port 6 or 7, the data appears on the bidirectional data bus simultaneously with the development of the -WRITE signal and the -PORT 6 or the -PORT 7 signal. The FUNCTION DCDR block in Figure 4-6

includes the random logic which enables the Multiplexer modules B37 and B49, and addresses the RAM according to the port selected. Since -READ is HI at this time, the Multiplexers allow data to flow to and be written into the RAM.

(b) Write to Port 5

The control word containing the strobe bit appears on the bi-directional bus as the -WRITE and -PORT 5 signals are developed. Data flow through the Multiplexers is clocked into the appropriate STROBE LATCH, which is set, and the BUFFER BUSY FF is also set.

(c) Read Strobe Latches

The Logic #2 microprocessor periodically reads the content of the STROBE LATCHES. It provides the binary coding into Decimal Decoder (Command) E61 on Lines 15 through 18, along with the -ENABLE INP signal, to gate the contents of the latches onto the IA1-IA8 bus and on into the microprocessor. The microprocessor will immediately execute the appropriate control action, which will include reading the data stored in the RAM, when the action is a carriage, print wheel, or paper feed movement.

In reading the RAM data, the Logic #2 microprocessor encodes the 15-18 lines to Decimal Decoder (Command) E61 to enable the RAM to release the high-order 4-bits on the first read pass, and then the low-order 8-bits on the second read pass. Upon completing the sequence, the Logic #2 microprocessor commands the reset of the BUFFER BUSY flip flop.

4.3.3.3 Operating Control Logic

1. Restore and Check

This version of the Logic #1 PCB does not include a RESTORE input line or a CHECK output line. These two functions are included, however, and operate as follows.

The RESTORE sequence may be initiated by the 8080 MPU issuing -DA2=HI and -PORT=LO signals. These two signals cycle the RESTORE FF D61-5 to momentarily deselect the printer and initiate the restore sequence in the Logic #2 microprocessor.

A CHECK condition, generated in the Logic #2 microprocessor in response to incomplete operating results, disables the select printer circuits, and sets signals on the bidirectional data lines. The 8080 MPU reads printer status prior to each command. Upon detecting the check condition, the 8080 MPU notifies the parent system, and waits for an operator response. When so instructed by operator action, the 8080 MPU issues the RESTORE commands mentioned above.

2. Ribbon Lift

This circuit is one of those mentioned earlier which initiates an immediate Logic #2 microprocessor response. -PORT 5=LO and -WRITE=LO signals clock the RC FF D61-9 through gate D49-6, and also clock the BUFFER BUSY FF. The output of RC FF D61-9 then goes to Line Driver G73 from where it is read into the Logic #2 microprocessor for immediate execution.

3. Carriage and Print Wheel Feedback

These circuits are nearly identical to those found on the standard Logic #1 PCB discussed above. The only significant difference is the appearance of inverters and RC networks in the even and pos lines which were included to enhance the noise immunity of the circuits. The following paragraphs are included as a review of the earlier discussion.

(a) Carriage Difference Counter Decrement Command Generator

When a carriage movement command is received, the Logic #2 microprocessor loads a value into its difference counter which represents the number of 1/120 inch (.212 mm) increments the carriage is to move. The microprocessor then supplies this value to the carriage servo drive circuits, which view it as an error signal, and proceed to generate servo drive which will move the carriage in such a manner as to reduce the error to zero. Signals fed back from the carriage servo motor's rotary transducer through the Transducer and Servo PCB's are received here. They are CAR. EVEN, CAR. POS A, and CAR. POS B. As shown in Figure 4-5, the timing relationships of these signals are that each makes one full cycle for each 1/60 inch (.423 mm) of carriage movement. This, when processed through the flip flops and gates, generates a single pulse out to Line Driver F73, called +CAR.X, for each half cycle or 1/120 inch (.212 mm) increment of carriage travel. The Logic #2 microprocessor uses this pulse as a count to decrement the difference counter. When this counter has been decremented to zero, the carriage is at its new commanded position, carriage movement is completed, and the microprocessor terminates the operation.

(b) Print Wheel Absolute Counter Increment-Decrement Command Generator

The Logic #2 microprocessor maintains a running log of print wheel position in its Print Wheel Absolute Counter, and thus always knows the current print wheel position. When it receives a command to print a new character, it calculates the shortest distance and direction to move the print wheel to place the commanded character in front of the print hammer in the shortest time. Once these questions have been answered, a value is established which is supplied to the print wheel servo drive circuits to be used as an error signal, along with a direction signal. The drive circuits then begin to move the print wheel in the desired direction. As with the carriage servo, signals fed back from the print wheel servo motor's rotary transducer through the Transducer and Servo

PCB's are received on this PCB. They are PW EVEN, PW POS A, and PW POS B. Referring again to Figure 4-5, the timing relationships of these signals are that each makes one full cycle for each increment of print wheel movement. Depending upon the sequence in which the signals appear (determined by the direction of print wheel movement), either a +PW INC (count up) or a +PW DEC (count down) pulse will be developed and sent to the Logic #2 Absolute Counter. When the microprocessor has added to or subtracted from the counter enough to bring the stored value equal to the commanded value, the print wheel motor is stopped, the movement is completed, the microprocessor terminates the operation and steps to the hammer fire sequence.

4. Miscellaneous Circuits

As mentioned earlier, these circuits include Option Jumper provisions, and a system clock. The Option Jumpers are discussed in detail in Section 3.

The system clock is a simple L-C feedback oscillator which provides the CLOCK A signal of 5 MHz +/-10% for use as the basic clock for the printer circuits.

4.3.4 Logic #1 PCB Assy, Special D, #40725-05

This version of Logic #1 PCB applies to those standard Model 1345A HyType II Printers configured for Special D use. Refer to Figure 7-2c, Schematic Diagram.

4.3.4.1 Initialization and Start-Up

During the restore sequence following application of power to the printer, the Logic #2 microprocessor issues a series of binary coded commands to CONTROL LOGIC RESET Decimal Decoder F49. F49 then issues clear signals to RESTORE FF H61-5, Strobe Latch FF's F61-3/-5 and F73-3/-5, RIBBON LIFT FF H49-5, Carriage Decrement FF D25-5, and a preset signal to Print Wheel Increment-Decrement FF's A13-3/-9. These actions ready the circuits for operation.

The printer can accept commands, however, only after it has been selected. This is done by the controller placing a LO signal on the -SELECT PRINTER input line. -SEL PTR=LO inverts to a HI in passing through its line receiver B61-13/D49-2 to enable gates G25-3, G45-3/-5 and G49-5. Also this LO, through inverter H25-12, enables gates D73-2/-14, C61-2/-3/-13 and -14. Enabled gates G45-3 and G49-5 release the PRINTER READY and PAPER OUT status signals to the interface. Gate G45-5 enables the END OF RIBBON lamp signal, while the signal through H25-12 enables RIBBON LIFT, RESTORE, and STROBE inputs. Enabled gate G25-3 combines with the Not In Restore status from RESTORE FF H61-5 to enable gates G25-6 and -11. The Not In Check status of +CHECK=LO through enabled gate G25-11 and inverter H25-10 establishes a HI at gate G25-6 which is +(-CHECK·-RESTORE·+PRINTER READY·+SELECT PRINTER).

The signal G25-11=LO is also supplied to gate G37-5 where the signal -CHECK=HI is generated and passed to the interface as a Not in Check, Not in Restore status signal to the controller.

Gate G25-6=HI enables gates E13-8/-11, G45-3 and G49-3, and clears FF H61-9. The enabling of E13-8 and the clearing of FF H61-9 prepares the Strobe Latch circuit. Enabled gate E13-11, in the absence of a PAUSE command, enables the CAR., PF, and OPT READY gates of G69-5, G73-3/-5, and gate G25-8. In the absence of an END OF RIB.=LO signal, G25-8 will enable the PW READY gate. Then, in the absence of an incoming STROBE, these four READY gates will all pass LO signals to the interface as status of printer signals to the controller. The printer can now accept commands.

4.3.4.2 Command Entry

The controller places LO (true) signals of 1.4 usec minimum duration on the appropriate data lines, followed .2 usec later by a LO (true) signal of 1 usec minimum duration on the appropriate STROBE line.

The LO data bits pass through their inverting line receivers as HI signals, and are presented to the Data Register Files B37, C37 and D37 as unaddressed and unprocessed data.

If the -SELECT PRINTER input is LO, and the printer is not in a check or restore cycle, the output of gate G25-6 will be HI. G25-6=HI is presented to gate E13-8. In the absence of a latched strobe signal, E13-8 will be disabled and its LO output will clear FF H61-9.

The output of gate H73-3 is LO in the absence of a STROBE input. This LO combines with a HI from gate G25-6 at gate E13-8, and places a LO on the clear input to FF H49-9 to keep the FF in its clear state. This produces a HI on the -Q output to disable gate D49-14 and maintain a LO on the clock inputs to the STROBE LATCH FF's F61-3/-5 and F73-3/-5. The appearance of a LO signal on any one of the four STROBE inputs produces a HI at gate H73-3. This HI is presented to the D input of FF H49-9, and also enables gate E13-8 which then enables FF H49-9.

The STROBE=LO signal is also seen as a HI on one of the inputs to gates E73-3/-8. This HI propagates through these gates and through gates H73-6/-8 to the D input of FF H61-9. FF H61-9 is clocked with the -CLOCK A signal. With its next positive excursion, the -CLOCK A signal will switch FF H61-9 and pass the HI on the D input to the Q output, and on to clock FF H49-9. H49-9's -Q output will go LO, to enable gate D49-12, and to send a -WR=LO write signal to the Data Register Files as an instruction to accept the incoming data and data address. Enabled gate D49-12 will pass +CLOCK A pulses to the clock inputs of the STROBE LATCH FF's. With the next negative excursion of +CLOCK A, these FF's will latch, excluding other strobe signals and/or any strobe signal less than 1 usec duration. The -Q outputs of the latch flip flops go to READY gates G69-3/-5 and G73-3/-5, where the appropriate READY line is driven HI as a busy signal to the controller and to gates E61-3/-6/-8 and -11. The -Q outputs from the Paper Feed and Option STROBE LATCH FF's also go through gate G37-3 to clock CYCLE DATA LATCH FF G61-5. The Q outputs of the STROBE LATCH FF's go to Line Drivers E37 and F37 as address instructions for the microprocessor. The Q output from the Print Wheel STROBE LATCH FF also goes to the D inputs of CYCLE DATA LATCH FF's G61-5 and -9. The Carriage STROBE LATCH FF's Q output clocks CYCLE DATA LATCH FF G61-9, and the

two CYCLE DATA LATCH FF's then produce the +PBH (print before horizontal) and +PBV (print before vertical) instructions for transmittal to the microprocessor.

The active LO signals from the strobe line receivers are applied to gates E73-3 and -11. The output of these two gates is sent as +PW/CAR. STB and/or +PW/OPT STB to the Data Register Files to supply an address for the data being received in conjunction with the strobe where the inputs from the gates are decoded as an address for data as follows:

E73-3	=	LO	HI	HI	LO
E73-11	=	LO	HI	LO	HI
Address	=	PF	PW	CAR	OPT

4.3.4.3 Operating Control Logic

1. Restore and Check

A restore command is received either as a -RESTORE=LO signal from the controller, or as a command from the Logic #2 microprocessor. The microprocessor command will place a LO clear pulse on RESTORE FF H61-5, while the -RESTORE=LO signal will invert through Line Receiver B61-8/D73-14 to clock the FF. Either action will cause FF H61-5 to switch over, producing +RESTORE FF=HI from its Q output, and place a LO on pin 2 of gate G25-3.

If this is a controller command, the +RESTORE FF=HI signal will proceed through Line Driver E37 to the microprocessor on Logic #2 PCB to put the microprocessor into the restore sequence.

In any case, the -Q=LO to gate G25-3 disables the strobe logic, and drives all the READY gates HI. This disables the printer until the microprocessor has completed the restore sequence and clears FF H61-5.

A check condition occurs whenever printer systems are unable to complete a carriage or a print wheel command. Whenever this occurs, the microprocessor is forced into a program hold situation and issues a +CHECK=HI signal. This HI disables gate G25-11, which in turn disables the strobe logic and drives all the READY gates HI to disable the printer. In addition, a -CHECK=LO signal is sent to the controller to indicate a check condition. A check condition requires a restart of the microprocessor's programmer to clear. As mentioned before, the restore sequence is the only means of doing this. Restore is initiated here usually by controller command, but can be started by cycling printer power input.

2. Ribbon Lift

A ribbon lift command enters as a -RIBBON LIFT=LO signal thru Line Receiver B61-1/D73-2, and is applied as a HI to the D input of RIBBON LIFT FF H49-5. H49-5 is clocked by a HI signal from the Print Wheel STROBE line receiver. When clocked, which occurs only in conjunction with a print wheel

command, the FF switches over to produce the signal +RIB LATCH=HI. This HI is sent to Line Driver A37, where it is read by the Logic #2 microprocessor for execution as a command to lift the ribbon. Having read in the command, the microprocessor then clears the RIBBON LIFT FF through the CONTROL LOGIC RESET Decimal Decoder F49.

3. Carriage and Print Wheel Feedback

(a) Carriage and Print Wheel Status Synchronizers

Four status signals, called CAR. EVEN, PW EVEN, CAR. HOME and PW HOME are required by the microprocessor to help maintain its record of carriage and print wheel position. The microprocessor's operation is timed by the main system clock, and since these four signals are random in nature, they must be synchronized with the clock to be useful to the microprocessor.

FF's E25-5/-7/-12 and -15 are used to generate clock synchronized Q outputs for each of the four input signals. These are then supplied to the microprocessor through Line Driver F37.

(b) Carriage Difference Counter Decrement Command Generator

When a carriage movement command is received, the microprocessor establishes a value in its carriage difference counter equal to the number of increments the carriage must move to reach the new command location, and also feeds the position data to the carriage servo circuit where the newly generated positional error signal is used to develop the carriage motor drive power.

As the carriage drive motor moves in response to this error signal, its shaft position transducer produces a set of phase modulated RF signals which are fed to the Transducer PCB. The Transducer's circuits process these inputs and generate a series of triangular wave position signals which are sent to the Servo PCB. Three signals called CAR. EVEN, CAR. POS A, and CAR. POS B, are derived from these by the Servo circuits and supplied to Logic #1 PCB as inputs to the Carriage Difference Counter Decrement Command Generator circuit. This circuit uses these inputs, as outlined below, to generate a series of pulses fed back to the microprocessor. One pulse is generated each time the carriage has moved one increment of 1/120 inch (.212 mm) and this pulse decrements the microprocessor's Carriage Difference Software Counter one count.

Refer to Figure 4-5. The CAR. EVEN input originates in the Carriage Servo Tachometer circuit. It consists of a series of square-wave pulses where the line level rises to its positive value and remains there as long as a carriage transducer signal called POS SIG #3 is negative. The line level then falls to zero when POS SIG #3 swings positive. This signal can then be used to mark those points when the car-

riage position is even. This is the data into the FF's C25-5 and -9, where each change in input line level represents that point where POS SIG #3 experiences a transition through zero. The CAR. POS A and CAR. POS B inputs to Exclusive OR gate B25-3 also originate in the Carriage Servo tachometer circuit. Their combined output from B25-3 alternately clocks the two FF's. When this clocking occurs following a POS SIG #3 transition, a HI is generated out of FF D25-5 to decrement the counter in the microprocessor.

The clear input to FF D25-5 is called -RST CAR. X. This is a signal sent from the microprocessor to acknowledge receipt of the decrement count, and to reset FF D25-5 in preparation for the next count. This signal is also sent during a restore sequence.

NOTE: The reader should also be familiar with the information given in subsection 4.6 SERVO PCB on the operation of the Carriage Position Tachometer circuit, to more fully understand the inputs to this circuit.

(c) Print Wheel Absolute Counter Increment-Decrement Command Generator

This circuit consists of FF's A13, C13 and D13, dual AND/OR inverter B13, inverters G13-6 and -8, and gates F13-3/-6/-8 and -11. The inputs to this circuit are exactly the same as the carriage circuit discussed above, being PW EVEN, PW POS A, PW POS B, and -RST PW X. The inputs perform the same functions in this circuit as their counterparts in the carriage circuit.

The difference between the two circuits is that where the carriage circuit's purpose is to decrement its Difference Counter only, the Print Wheel circuit must increment as well as decrement its Absolute Counter due to the independent bidirectional nature of print wheel rotation in executing commands. This circuit thus appears as a dual inverted command generator, when compared to the carriage circuit. The POS A and POS B inputs supply clock, data and clear inputs to the four flip flops. Their inverted forms are also exclusive OR'd by gate B25-11 to provide clock inputs to FF's A13-5 and -9. The Q outputs of FF's C13 and D13 are compared with the PW EVEN signal in the B13 Dual AND/OR inverter modules. The outputs of these devices, along with the Q outputs of FF's A13, propagate through a gate network of F13-3/-6/-8 and -11 to be coupled back as the D inputs to FF's A13. This network acts to prevent extraneous signals from being entered as print wheel movement counts. The -Q outputs of FF's A13-5/-9 are sent to the microprocessor through Line Driver A37 to either increment or decrement the microprocessor's Print Wheel Software Absolute Counter, where two pulses are equal to one print wheel petal (position) movement.

The preset inputs to FF's A13 is called -RST PW X. This is a signal sent from the microprocessor to acknowledge receipt of

the previous count, and to preset the FF's in preparation for the next count. This signal is also sent during the restore sequence.

4. Miscellaneous Circuits

Decimal Decoder modules E49 and F49 provide a means for the microprocessor to address the Data File Registers B37, C37 and D37, and Line Drivers A37, E37 and F37 by encoding input lines 15 through 18, -ENABLE INP, and -RST.

Through multiplexed binary coding of these inputs, a LO signal can be placed on any one of the several outputs. Examination of the circuits will reveal a capability to selectively clear the control logic flip flops, or address functions in the output modules. The -GR LO and -GR HI lines allow the microprocessor to read the 12-bit wide data input word into its 8-bit wide data input bus in two passes. The first pass sees -GR HI=LO enable the high order 4-bits in Register C37. The second pass sees -GR LO=LO enable the low order 8-bits in Registers B37 and D37. The -GATE CMD and -GATE STATUS lines applied to the Line Drivers A37, E37 and F37 control the input, storage and transmittal of the command inputs sent to the drivers. The -GATE JUMPER line is not used in this version, since the Option Jumpers have been omitted.

The Special D version of the Model 1345A HyType II Printer includes several additional features:

In lieu of an End Of Ribbon interface connection, this unit makes use of a control panel indicator lamp. The -END OF RIBBON=LO signal disables gate G25-8 to drive the Print Wheel READY gate HI, and passes through inverter H25-4 and select printer enabled gate G45-5 to turn on the END OF RIBBON lamp.

In addition to the normal -PRINTER READY=LO interface status signal, this unit includes a PRINTER READY lamp circuit composed of gate G49-3. G49-3 is enabled by a -PAUSE SW=HI signal from a control panel PAUSE switch (switch open) discussed below.

This unit also includes a control panel PAUSE switch, which allows the operator to momentarily halt printer operation, and then continue without restore. Closing this switch (-PAUSE SW=LO) extinguishes the PRINTER READY lamp by disabling gate G49-3, drives the Print Wheel READY gate HI to stop print commands, and places a HI on the D input to PAUSE FF E25-2 through gate B25-6. With the next +CLOCK A=HI pulse, FF E25-2 generates the signal +PAUSE=HI which is sent to Line Driver A37 for use by the Logic #2 microprocessor to halt the program counter. Releasing the PAUSE switch then allows the printer to continue.

Finally, instead of a Cover Open status signal to the controller, this machine inverts an incoming -COVER OPEN=LO signal, through inverter H25-2, which is then applied to

4.4.2.5 Model Variations

The printer's #40510-XX Logic #2 microprocessor circuit is applicable to a wide variety of programs. On this PCB, these variations all use the same basic circuit with variations seen as component changes only in the three program storage Programmable Read Only Memories (PROM's). The several versions, or PROM sets, currently available are described briefly below in Table 4-4 and are reflected in the PCB assembly by dash numbers.

4.4.3 Logic #2 PCB Assy, Std/ESD, #301850-XX

Refer to Figure 4-7, and to Figure 7-3b Schematic Diagram

4.4.3.1 Initialization and Start-Up

With the application of power to the printer, the power monitor circuit on the Carriage Power Amplifier PCB produces a +POWER ON=LO signal to this circuit. +POWER ON=LO initializes all Logic #2 counters, registers, and flip flops to their zero and/or reset states. Simultaneously, the main system CLOCK A on Logic #1 PCB starts up, and its 5 MHz output stabilizes.

As soon as the power monitor circuit senses its monitored voltages at their proper levels, it produces a +POWER ON=HI signal. +POWER ON=HI releases the initialization process, and the microprocessor Program Counters C73/D13 begin to run from step zero.

4.4.3.2 Program Control Loop A

Beginning on step zero, PROMs A57/A72 issue program instructions on lines I1 thru I16. These instructions flow to all parts of the processor, and to circuits on Logic #1 PCB. Depending on the particular step being processed and the results obtained, these same lines, being multiplexed, may in part carry program branch instructions. Such instructions are looped back to the Program Counters C73/D13 as new program addresses Operand A Registers D73/E13.

The multiplexed output of programmed instructions from this loop control and coordinate all the functions and data handling processes within the printer.

4.4.3.3 Data Processing Loop B

Data input from Logic #1 PCB, along with the data address information, is multiplexed into Operand A Registers D73/E13. At the proper time this information is latched onto the RA bus lines and directed to Adders E25/E61, and to the RAMs F49/E49/F37/E37 for storage. Note that each data address, such as paper feed or carriage motion information, has its own storage register in the RAM. Again, at some point later in the program, the stored data is ordered out of RAM and on to the main data transfer bus for loop circulation thru Operand A and B registers and back thru the arithmetic circuits of Comparators D25/D61, Adders E25/E61, and their associated decoding network to the RAM. In the cycle, Table ROM A17 inserts constant factors for the particular function being processed, such as hammer energy factors for the particular character being printed.

4.4.3.4 Data Output Loop C

During a program cycle, the A Registers may, from time to time, contain operands for the arithmetic units, new addresses for the low order 8-bits for the program counter, or data to be loaded into the output latches.

In this instance, when stored data has been fully processed and is ready for use, it is called from the RAM and latched on to the A Register output lines. From there, the program then moves the data to the Output Data Latches F25/G13/G25/F13.

The Data Output Loop C is then closed by means of positional feedback to the input and Registers A and B thru Logic #1.

The main purpose of the output latches is to be able to collect serialized bit data and to present it simultaneously, or broadside (parallel) to the servo circuits following.

4.4.3.5 Model Variations

The printer's Logic #2 microprocessor circuit is applicable to a wide variety of programs. On this PCB, these variations all use the same basic circuit with variations seen as components changes only in the three program storage Programmable Read Only Memories (PROMs). The several versions or PROM sets currently available are described briefly in Table 4-4, and are reflected in the PCB assembly dash number.

4.5 TRANSDUCER PCB Assy, Std., #40515-04

4.5.1 General Information

This PCB contains all the circuits necessary to generate the sine-wave drive for the carriage and print wheel transducer stator windings, to demodulate the resultant phase-modulated carrier signal coming from the two transducer rotor windings, and to produce from each carrier signal three triangular position signals and one linear mode signal each for the carriage and print wheel tachometer circuits on the Servo PCB. Refer to Figure 7-4 Schematic Diagram.

4.5.2 The Sine-wave Drive Generator

Refer to Figure 4-8 for illustration of the waveforms discussed below.

Figure 4-8 shows the waveforms generated by modules H24 and H48. These two modules are 4-bit parallel access shift registers which are driven by the 5 MHz -CLOCK A input from Logic #1 PCB, and connect to form a 16 circuit. The outputs are square waves as shown, where the output H48-15=HI is followed one clock cycle later by H48-14=HI, and so forth. When H24-12 goes HI, feedback through H24-11 and thru gate H30-8 drives the output at H48-15 LO. This condition then cascades through the registers again until H24-12 goes LO, when H24-11 will drive H48-15 HI to start the cycle again. These square-wave outputs are connected through inverters, pull-up resistors, and load resistors to four output lines - two for carriage circuit use, and two for print wheel circuit use. The inverters act as switches, allowing

current to flow through the associated load resistors whenever the inverted output is LO. Seven of the inverter outputs are selected for summation to form each of the four output signals -CAR 1, CAR 3, PW 1, and PW 3. The values of the several load resistors plus a capacitor connected from each output line to their common return line produces a set of two-phased sinusoidal waveforms as shown for both the carriage and the print wheel circuits. These two signals are fed to the stator windings on each position transducer.

4.5.3 Servo Position Transducer

Each Servo Position Transducer consists of rotor and stator members made up as flat disks with windings laminated on adjacent surfaces. The rotor is mounted on the free end of the servo motor shaft, with the stator mounted over it and fastened to the motor casing. Output signals from the rotor are picked up by means of an axially mounted rotary transformer.

TABLE 4-4
HyTYPE II LOGIC #2 PROCESSOR PCB PROM CHART

NEW	OLD	Table PROM	LO PROM	HI PROM	MODEL
		A17 A43	A57 A73	A72 A58	
301850-01	40510-07 (08)	13065-01	13066-05	13067-06	1345 Std (ESD)
-02	-81	-81	-45	-46	1345 Sp A
-04	-40 (11)	-34	-35	-36	1355WP Std (ESD)
-05	-48	-01	-45	-46	1345 Systems
-06	-56	-51	-05	-06	1345 Sp S
-07	-67 (68)	-01	-65	-66	1345 Sp D (ESD)
-08	-78 (79)	-78	-05	-06	1345 Sp K (ESD)
-09	-74 (75)	-73	-45	-46	1345 Sp E (ESD)
-10	-76 (77)	-76	-35	-36	1345 Sp DTC (ESD)
-11	-94 (95)	-01	-94	-94	1345 Sp T (ESD)
-12	-97 (92)	-91	-05	-06	1345 Sp DS (ESD)
-13	-85 (15)	-84	-85	-85	1355WP 96 OSD Sort (ESD)
-14	-86 (87)	-86	-35	-36	1355WP Sp E (ESD)
-15	-89 (16)	-88	-85	-85	1355WP 96 Diablo Sort (ESD)
-16	-90 (91)	-90	-90	-90	1355WP 96 Financial (ESD)
-17	- - -	-97	-97	-97	1355WP Sp AES
-18	-29 (30)	-24	-25	-26	1355HS Std (ESD)

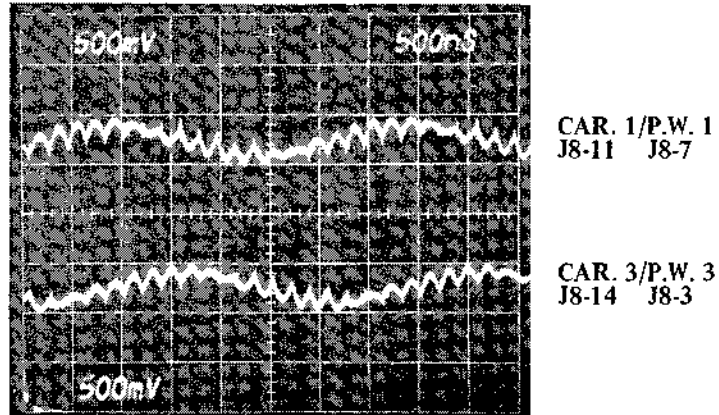
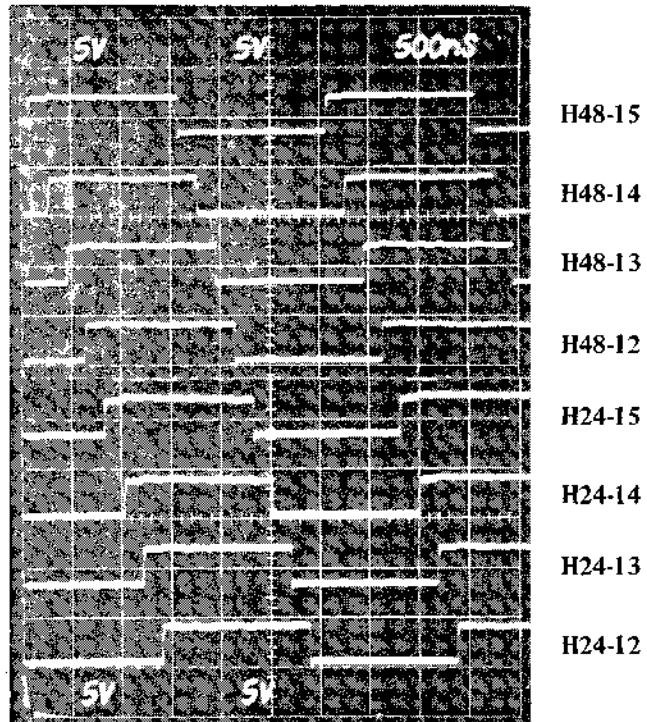

Figure 4-8
SINE-WAVE DRIVE GENERATOR WAVEFORMS

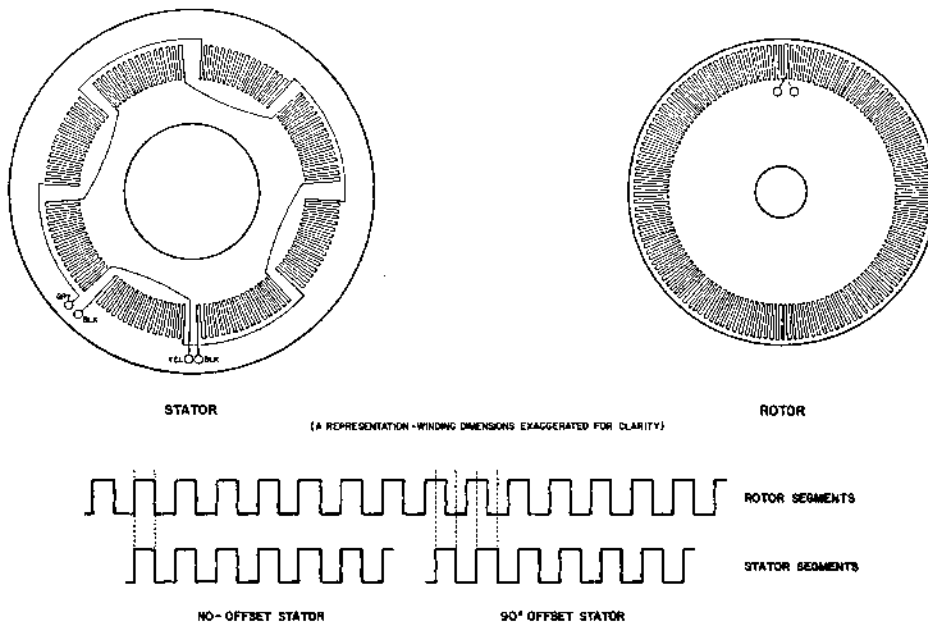

Figure 4-9 SERVO POSITION TRANSDUCER

As shown in Figure 4-9, the stator has an eight segment winding, with alternate segments connected together to form two groups of four segments each. The four segments of one group are displaced laterally from the other group by a distance equal to one-half a winding width. This displacement is equal to a 90° phase difference.

The rotor has one symmetrical winding.

The two sinusoidal outputs shown in Figure 4-8 are introduced into the transducer's stator windings. Since all the windings in the device are nearly 1:1, the only transformation of the inputs is that the summed output is phase modulated by rotor movement. The phase modulated output from the transducer is coupled back to a 2-stage RF Amplifier and a squaring circuit.

4.5.4 Servo Feedback Amplifier

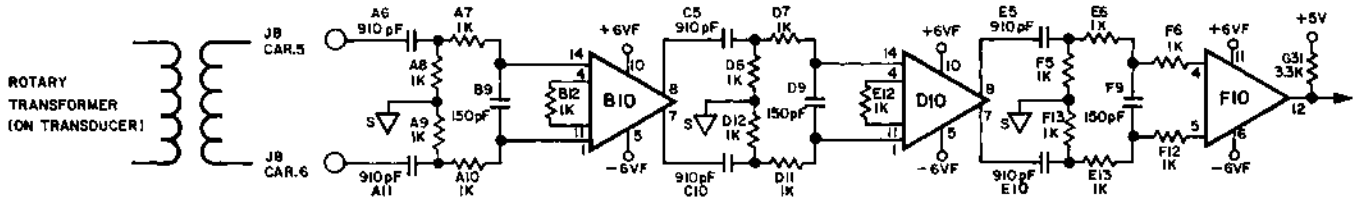
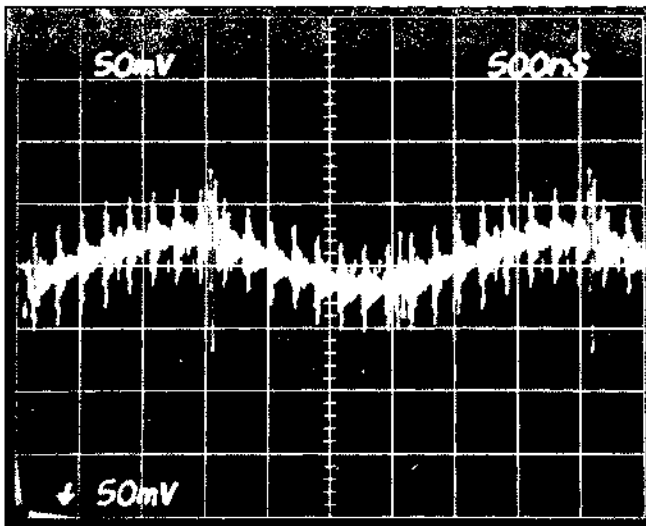

Figure 4-10 SERVO FEEDBACK AMPLIFIER

Figure 4-10 is a partial schematic showing this circuit as seen in the carriage channel. Since both carriage and print wheel channels are so nearly alike, the balance of this discussion will follow the carriage channel only.

Figure 4-11 shows waveforms taken in this circuit. Waveform A is the phase modulated servo amplifier transducer output, as seen at the input to the first video amplifier B10-1/-14. Amplifier B10 has an adjusted



A
 1st VIDEO AMPL. INPUT
 BIO-1/14 (BIO-1 INVERTED)

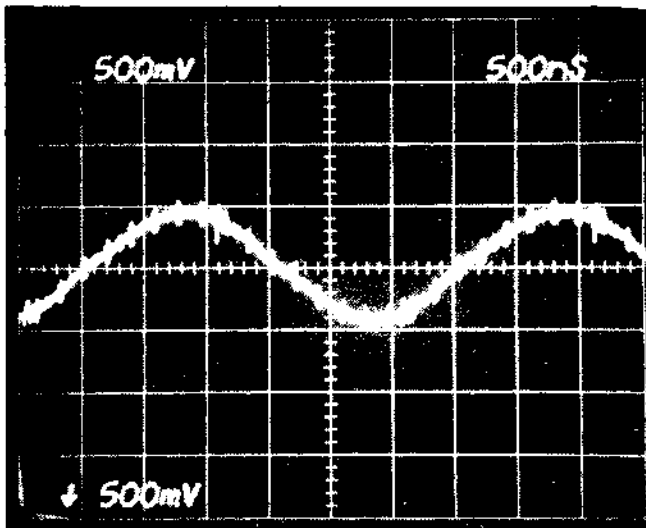

B
 1st VIDEO AMPL. OUTPUT
 BIO-7/8 (BIO-7 INVERTED)

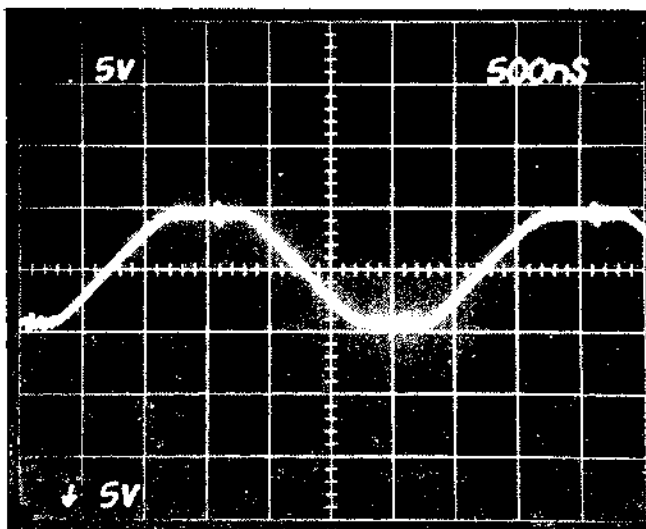

C
 2nd VIDEO AMPL. OUTPUT
 DIO-7/8 (DIO-7 INVERTED)

Figure 4-11 SERVO FEEDBACK AMPLIFIER WAVEFORMS

gain of approximately 20. It amplifies and partially filters the input as shown at its output, waveform B, taken at B10-7/-8. The second video amplifier D10, also with a gain of approximately 20, further filters the signal and generates a 10 volt p-p output waveform C which displays some squaring of saturation limiting. This output, from D10-7/-8, is applied to a high speed squaring comparator module F10. F10 is overdriven, and produces a square-wave output.

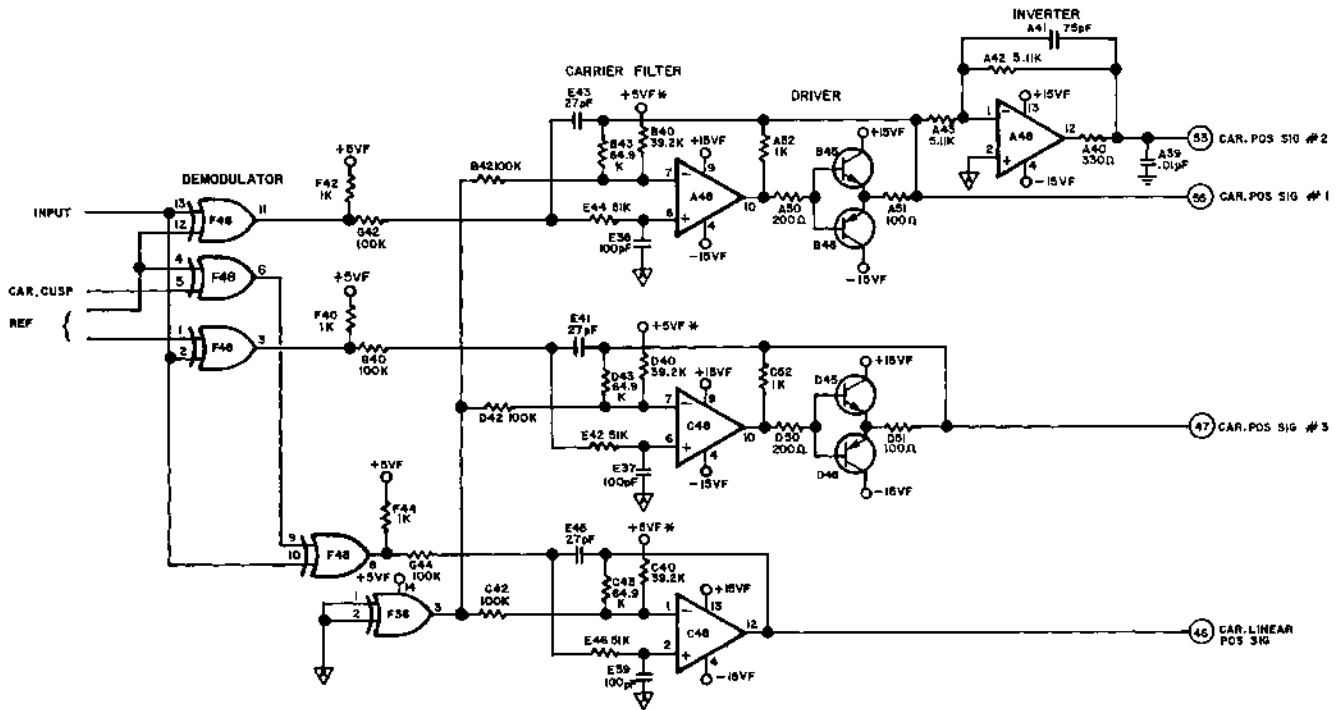

Figure 4-12 SERVO FEEDBACK DEMODULATOR/INTEGRATOR/AMPLIFIER

Figure 4-12 is a partial schematic showing the Servo Feedback Demodulator/Integrator/Amplifier circuit. Figure 4-13 shows waveforms taken in this circuit.

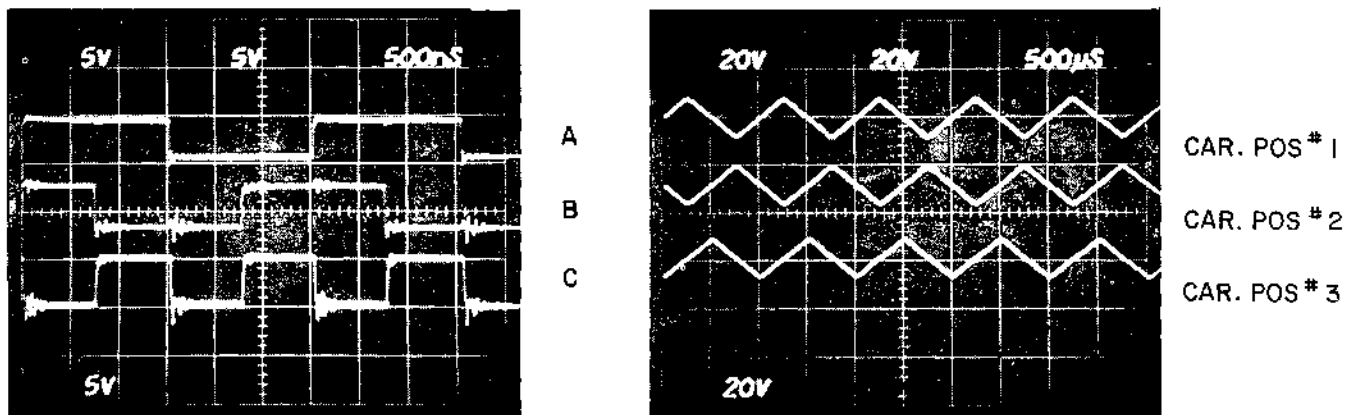

Figure 4-13 SERVO FEEDBACK DEMODULATOR/INTEGRATOR/AMPLIFIER WAVEFORMS

The square-wave output of comparator F10 is inverted and applied to Exclusive OR gates F48-3/-11 as the squared and inverted phase modulated signal from the carriage servo transducer, along with reference square waves from the sine-wave driver generator circuit.

As shown in Figure 4-13, by observing the two inputs to either F48-3 or F48-11 along with the gates' output on a multichannel oscilloscope which is synchronized to the sine-wave drive generator and slowly moving the carriage by hand, the square-wave input from comparator F10 (B) will appear to move with respect to the input on either pin 1 (F48-3) or pin 12 (F48-11) from the sine-wave generator (A). Then, the output (C) from either F48-3 or F48-11 will be a square wave whose relative HI-LO status will vary as the HI-LO states of the two inputs vary with respect to each other.

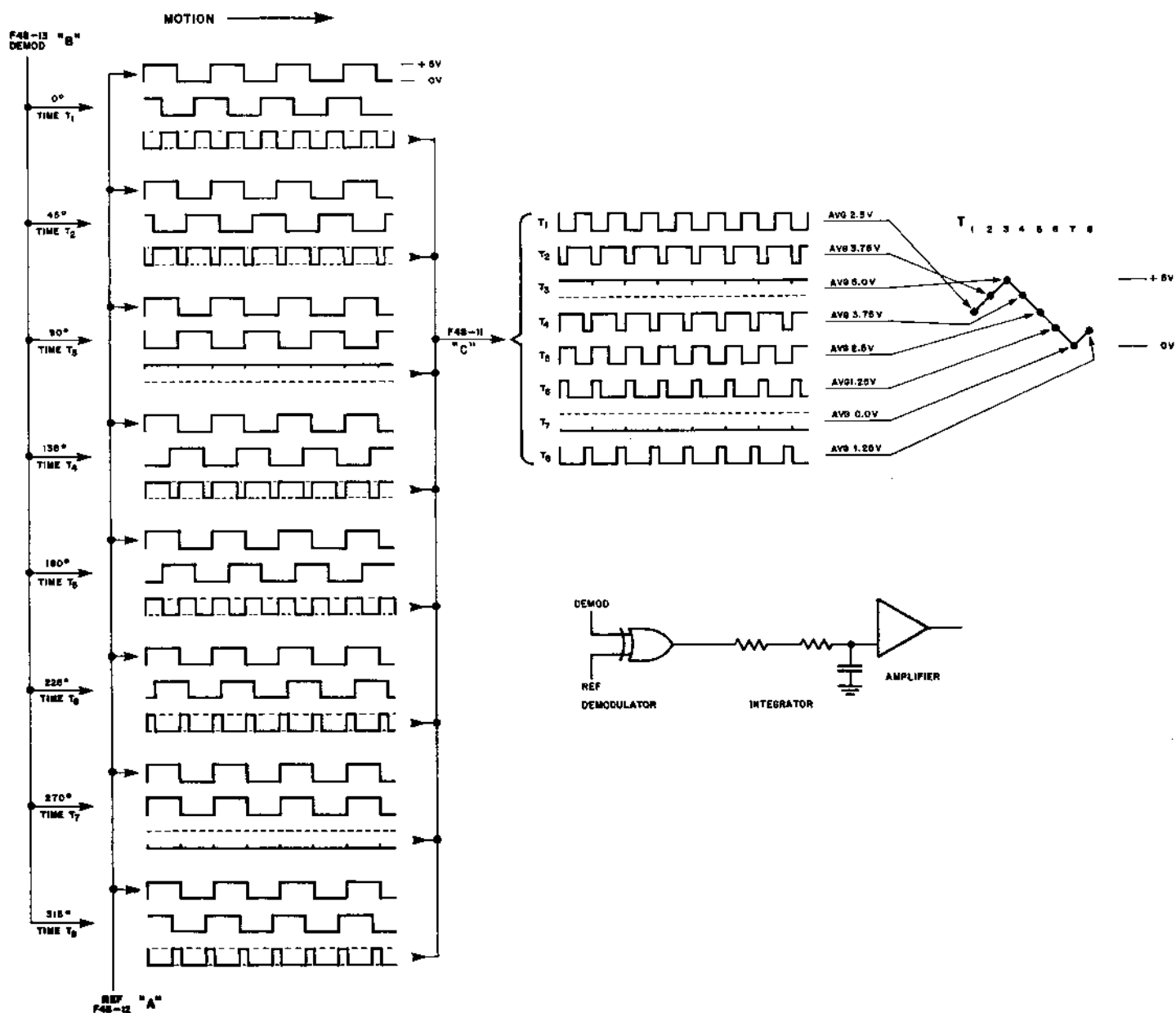

Figure 4-14 WAVEFORM ANALYSIS

Figure 4-14 illustrates the development of the output waveform (C) from the two input waveforms (A and B), and further shows the saw-tooth waveshape developed in the integrating circuits for amplifiers A48-10 and C48-12. The output of A48-10 is then supplied to amplifier A48-12. These three amplifiers produce the waveshapes called CAR POS SIG #1, CAR POS SIG #2, and CAR POS SIG #3. In addition, when the carriage has stopped, the lower circuit shown in Figure 4-12 produces a signal called CAR LINEAR MODE, which is used to detent the servo.

4.6 SERVO PCB CIRCUITS

4.6.1 General Information

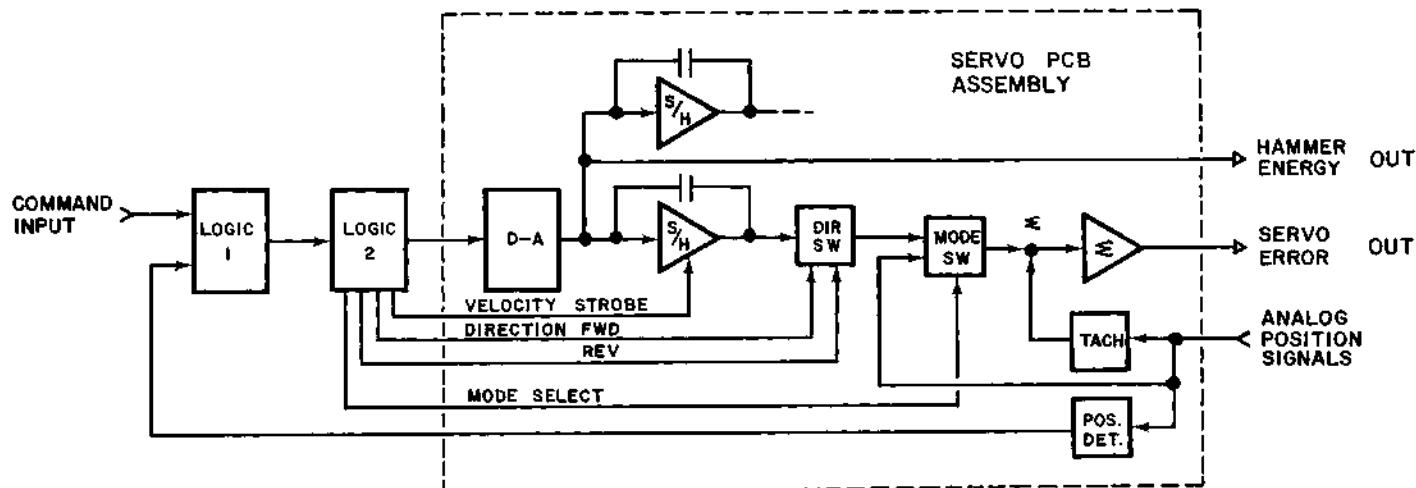

Figure 4-15 SERVO PCB BLOCK DIAGRAM

As shown in Figure 4-15, this circuit follows Logic #1 and Logic #2 in the command response chain, and has four functions. First, it receives strobed processed command data from Logic #2, and converts this digital data input to a voltage level representative of the absolute value of the desired velocity at which the carriage or print wheel is to be moved. Since incoming data are multiplexed, the D-to-A Converter part of the circuit is common, with the print wheel and carriage functions being steered to nearly identical but separate sample and hold circuits. The velocity level output from the sample and hold circuit is then switched in polarity to control direction of movement, and the resultant polarized voltage is presented to a summing amplifier as the velocity command signal. Second, dual tachometer circuits convert incoming analog position signals (XX POS SIG #1, #2 and #3) to a voltage level which represents the actual servo velocity. In addition, these circuits derive a series of three digital position signals (XX POS A, POS B and EVEN). These position signals represent distance moved and are supplied back to Logic #1 PCB where they are used to generate increment and/or decrement counts for the position memories in Logic #2. Third, the voltage level of velocity is summed with the velocity command signal to develop a 0 to 7 volts maximum SERVO ERROR signal. SERVO ERROR is used on the Power Amplifier PCBs to develop the actual servo motor drive current. Fourth, the D-to-A Converter

output is used to process print hammer energy commands which are then used to develop the actual print hammer drive current on the Print Wheel Power Amplifier PCB.

Refer to Figure 7-5a Schematic Diagram.

4.6.2 Servo PCB Assy, Std., #40520-04

4.6.2.1 The D-A Converter

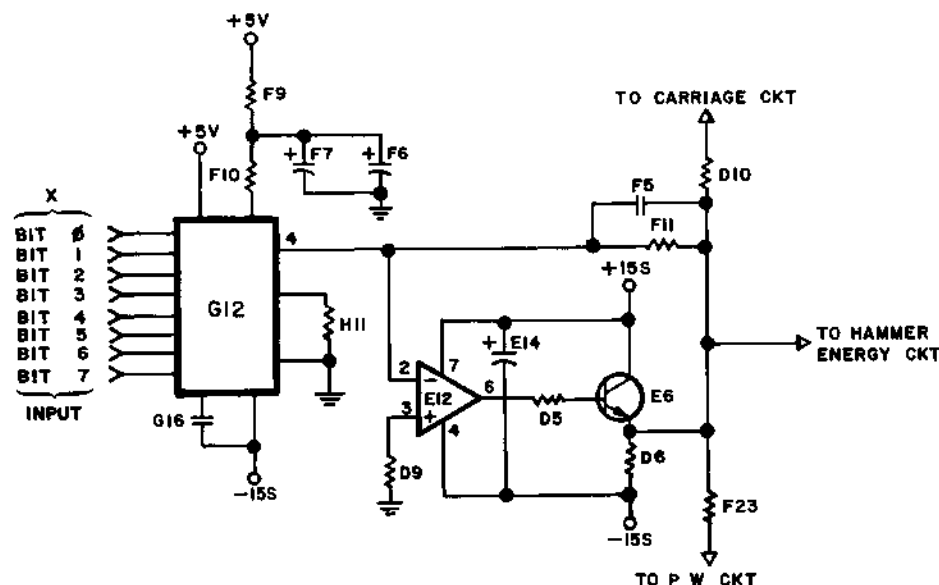

Figure 4-16 D-A CONVERTER CIRCUIT

This common input stage serves both the carriage and print wheel channels as well as the print hammer circuit. It consists of 8-bit digital-to-analog converter module G12, operational amplifier E12-6, buffer/driver transistor E6, and associated circuit components. Figure 4-16 is a partial schematic illustrating this circuit. Converter G12 converts the binary input from the microprocessor to a current. The amplitude of this current represents either a speed command for carriage or print wheel, or a hammer energy command for the print hammer. The circuit's operating parameters are set by the value of resistors F9 and F10 in the +5V supply line to G12 pin 14, so that when all digital inputs are HI the output current at pin 4 will be 99.6% of the reference current of approximately 1 mA on pin 14. When all digital inputs are LO, the output on pin 4 will be 0 mA. E12-6 is a current-to-voltage converter, with its instantaneous voltage level stored on capacitor F5 for reference between updating inputs from the microprocessor.

4.6.2.2 The Sample and Hold Circuit

Figure 4-17 illustrates a typical Sample and Hold circuit for either the carriage or print wheel channel, and shows the basic timing involved. The circuit consists of an input switching FET, an operational amplifier A coupled to a buffer/driver transistor Q, and associated components.

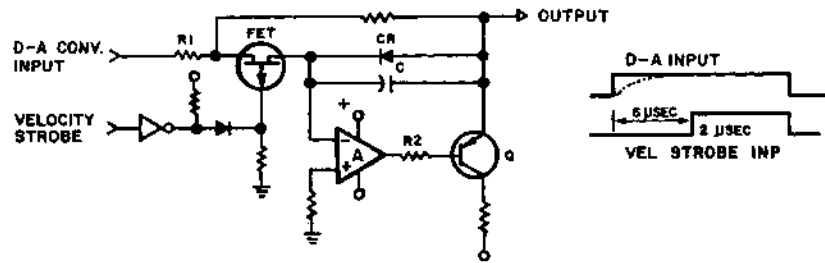

Figure 4-17 TYPICAL SAMPLE AND HOLD CIRCUIT

In operation, the output of the D-A Converter is presented to the switching FET through resistor R1 (D9 in the actual carriage circuit, F23 in the actual print wheel circuit). Approximately 6 usec after the arrival of data on the data bus input to the D-A Converter, the microprocessor on Logic #2 issues a 2 usec Velocity Strobe pulse through a line receiver network to turn on the FET. When turned on, the FET couples the D-A output voltage to holding capacitor C in the feedback circuit of amplifier A. Capacitor C holds this voltage until the microprocessor again strobes in the D-A output. The microprocessor's cycle rate is so fast that it may update the charge on the capacitor 100-200 times before it actually modifies the data. The microprocessor can modify the D-A input data only when the associated transducer has experienced a track crossing (generated required count pulse(s)), which occurs each time the carriage or print wheel has moved a prescribed distance. Amplifier A follows and inverts the charge on capacitor C, to produce a 0-to-negative going voltage which represents the velocity command for the associated servo. Transistor Q buffers the amplifier output, and provides drive current for the circuits following.

4.6.2.3 Servo Direction Switching

Refer to Figure 7-5 Schematic Diagram. The output of the nearly identical Carriage and Print Wheel Sample and Hold circuits follow identical paths. One path goes through a 10K resistor to a switching FET, while the other path goes through an inverting operational amplifier to a second switching FET, with the output of both of the FET's tied together. This means that the negative going output of the Sample and Hold circuit is supplied as a negative going voltage to one FET, and as a positive going voltage to the other FET. The gates of these FET's are controlled by inputs from the microprocessor labeled FWD and REV through inverters and voltage divider networks. The microprocessor can then select the correct polarity of signal to be presented to the Summation circuit to control ultimate direction of servo movement.

During those times in printer operation when carriage and/or print wheel motion has stopped, and before the hammer fire sequence is complete, the associated servo must be detented to hold its position. To accomplish this, a signal called LINEAR POS SIG is generated in the Transducer circuit and presented to a third switching FET whose output is also tied to the Summation circuit. This FET is A12-7 for the carriage circuit, and A32-15 for the print wheel circuit. The input to the gates of these FET's comes from the microprocessor through the normal inverter/divider network, and is labeled LINEAR MODE. The

associated servo system is detented by the microprocessor gating in the LINEAR POS SIG to the summation point, while at the same time holding the two associated position switching FET's in their OFF state.

30 msec after gating in the LINEAR POS SIG following the last position command strobe, the microprocessor activates the SERVO DISABLE signal. This turns off the power amplifier and effectively removes current flow through the servo while it is at rest. This is called the Float Mode.

In the Print Wheel circuit, the absolute counter is maintained in synchronization with print wheel position at all times, even if the print wheel is manually moved or should drift. In this way, print wheel movement in response to the next command can start from wherever the print wheel happens to be when the command is received.

Carriage position information is not maintained within the printer circuits. Any carriage drift or noncommanded movement would desynchronize the controller's position information. Any carriage movement, therefore, triggers a response to remove the Float Mode and drive the carriage back to its last commanded position.

4.6.2.4 Servo Tachometer Circuits

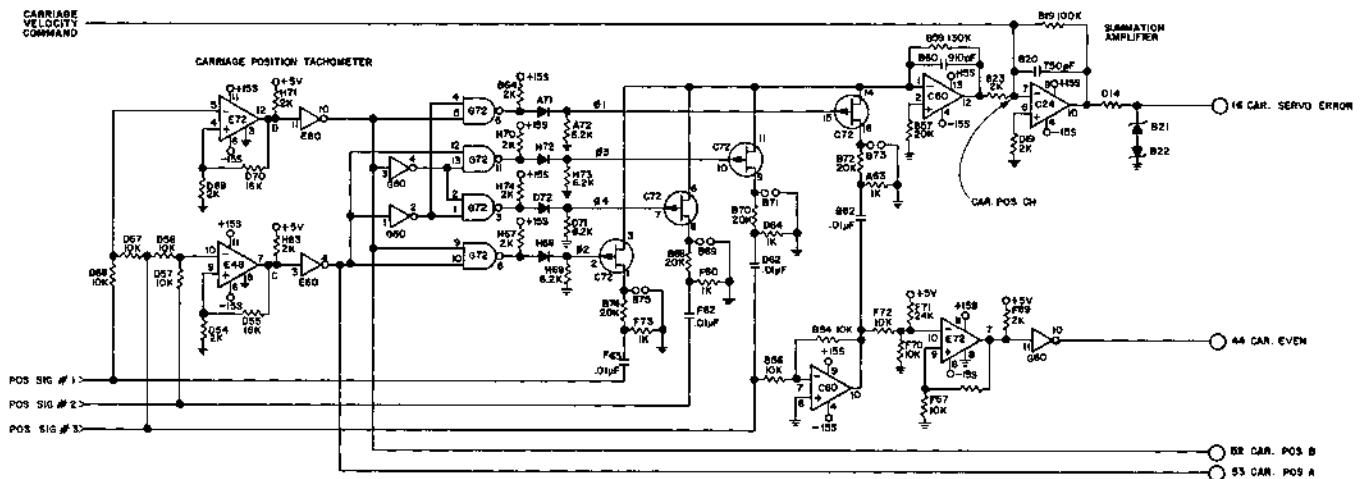
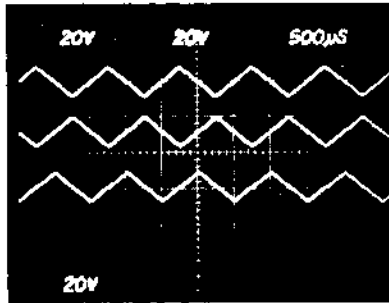

Figure 4-18 CARRIAGE POSITION TACHOMETER CIRCUIT

Figure 4-18 is a partial schematic diagram showing the Carriage Position Tachometer and associated circuits. Again, the Print Wheel circuits are nearly identical, so only the carriage circuit will be discussed.



A
B
C

Figure 4-19
CAR. POS TACHOMETER WAVEFORMS

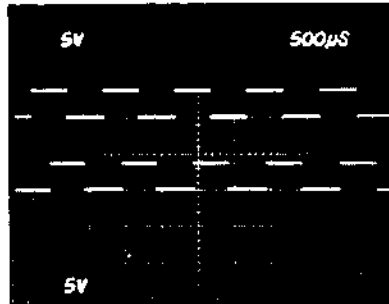

D
E

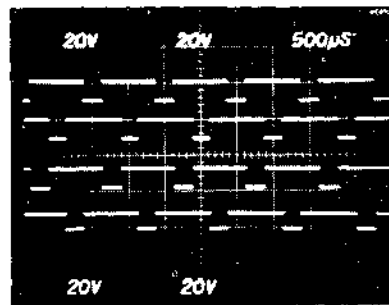

F
G
H
I

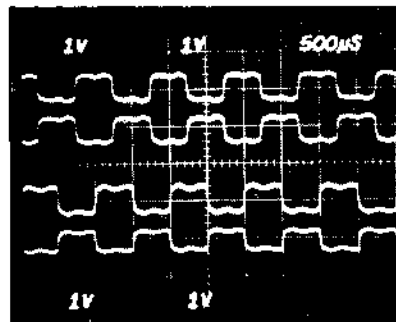

CAR. POS 1
CAR. POS 2
CAR. POS 3
CAR. POS 3

Figure 4-20
CAR. POS FET INPUT WAVEFORMS

Figure 4-19 shows waveforms taken in these circuits.

The design of the transducer on the carriage servo motor is such that each complete cycle of the sawtooth waveform inputs represents 1/120 inch (.212 mm) of carriage travel. Thus, while these sawtooth inputs do not vary in amplitude, they DO vary in frequency. This variation (or modulation) follows actual servo speed, with the waveshape itself tracking carriage position.

Refer to Figure 4-19. Modules E48 and E72 are high speed comparators. Their inputs are the sawtooth (or triangular) POS SIG waveforms A, B and C. Their actual outputs are square waves. The duration of these square waves follows the frequency of the sawtooth inputs. They pass through inverters, whose outputs are waveforms D and E from comparators E72 and E48 respectively, and are sent to Logic #1 as POS A and POS B. POS SIG #3 input is also sent through inverting amplifier C60-10, comparator E72-2, and inverter G60-10 to develop the CAR EVEN signal also supplied to Logic #1 PCB.

The POS A and B square waves are also channeled through a series of inverters and gates to supply waveforms F, G, H and I. These signals are used to control the feedback FET's C72-2, -7, -10 and -15.

The three POS SIG sawtooth waveforms, plus POS SIG #3 inverted, are supplied to the control FET's through differentiating networks. Figure 4-20 shows the waveforms taken at the capacitor-resistor junction in each network. The control pulse to each FET will turn the FET on to pass either the positive or negative part of the differentiated signal, depending on the direction of servo movement. Since servo velocity is seen here as frequency, the higher or lower the velocity, the higher or lower the level of the differentiated square wave. The voltage level of the outputs of the FET's are applied one at a time to the input (pin 1) of amplifier C60-12 with the combined result representing servo velocity. Amplifier C60-12 inverts the input and presents it to the velocity summation junction (pin 7) of Servo Summation Amplifier C24-10 as negative feedback.

4.6.2.5 Servo Summation Amplifier

This amplifier, C24-10 for carriage and C36-12 for print wheel, is the output of the servo velocity command circuit. It is an operational amplifier with a compensating capacitor, and a gain resistor in its feedback loop. The back-to-back 6.2 volt zener diodes in the output, plus their normal voltage drop, provide a bidirectional voltage clamp which limits the amplifier output to +/-7 volts. Since each volt of signal output here produces a fixed value of drive current later on in the servo motor, it is necessary to establish this voltage limit to safeguard the servo motor.

The input to this amplifier is then either the sum of actual velocity and velocity command voltages, or the LINEAR POS signal input and velocity signal which is used to detent the servo motor. The output is a voltage which is directly proportional to the desired amount of servo drive current. This output is labeled SERVO ERROR, and is sent to the associated Power Amplifier circuit.

4.6.3 Servo PCB Assy, 1355HS, #46020-02

This circuit is identical to #40520-04 with the exception of the feedback resistors in the Summation Amplifier circuits, and the PW LINEAR POS SIG input resistor. Refer to Figure 7-5b Schematic Diagram.

4.7 CARRIAGE POWER AMPLIFIER PCB CIRCUITS

4.7.1 General Information

This assembly includes the Carriage Servo Power Amplifier, the Paper Feed Drivers, and the Power Monitor circuits. It is located in Printer Electronics Compartment Slot D, and has a finned heat sink attached to it, to help cool the several drive transistors.

NOTE: DO NOT stand the HyType II Printer on its rear heat sinks. These finned heat sinks are mounted on plug-in circuit boards which can be easily damaged by this practice.

4.7.2 Carriage Power Amplifier PCB Assy, Std., #40525-10

4.7.2.1 Carriage Power Amplifier Circuit

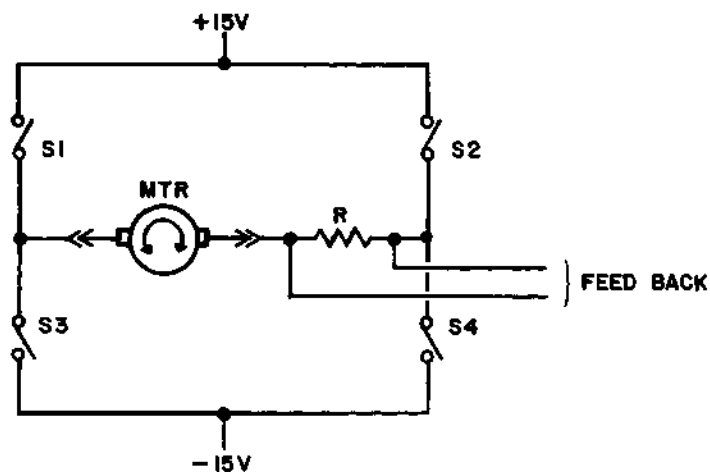

Figure 4-21 CARRIAGE POWER AMPLIFIER SIMPLIFIED DIAGRAM

This circuit supplies and controls current flow to the carriage servo drive motor. It is designed as an H bridge, allowing all current to flow through the motor from supply to supply instead of through circuit ground to avoid circuit noise problems. Figure 4-21 illustrates the basic circuit in simplified form, where certain transistors in the actual circuit are represented as switches. It may be seen that closing switches S1 and S4 will cause current to flow through the motor and resistor R right to left, while closing switches S2 and S3 will cause current flow left to right.

Referring to Figure 7-6a Schematic Diagram and the above will aid in understanding the operation of the circuit itself. Since the amplifier is composed of several similar circuits, only one path will be discussed.

Assume a CAR. SERVO ERROR signal of +1 volt for a commanded motor current of 1 ampere. The output from operational amplifier B55-6 will be low, and this will place a low potential on the base of transistor G58 to disable the Pulse Fwd circuit, and on the emitter of transistor G73. G73 will turn OFF. G73 being OFF turns transistor E70 OFF, which turns transistor E65 ON to turn ON Pulse Rev switching transistor F63.

The error signal is also supplied to amplifier A50-6. Amplifier A50-6 output will be negative with a positive input, which will turn transistor D42 OFF. This will turn transistor D45 OFF and transistor E44 ON to turn ON Drive Rev switching transistor D48.

Referring to Figure 4-21, transistor D48 is shown as switch S2, while transistor F63 is shown as switch S3. Turning these two transistors ON establishes a current path from the +15 volt supply through D48, resistor C53, the drive motor, and F63 to the -15 volt supply.

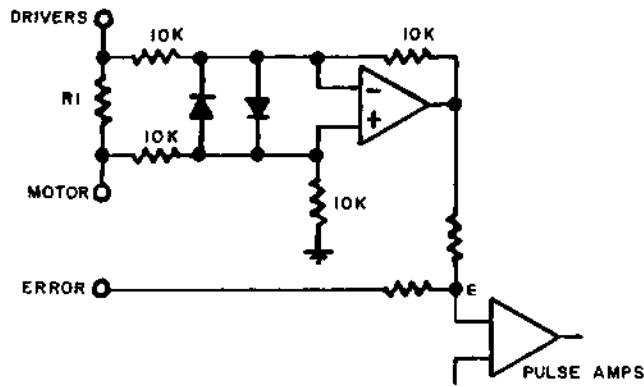

Figure 4-22 FEEDBACK INSTRUMENTATION CIRCUIT

Figure 4-22 is a simplified schematic diagram of the feedback circuit. This circuit includes the .1 Ohm resistor C53 (R1) located in one of the lines to the servo motor, across which is connected a precision balanced 10K Ohm resistor network and difference amplifier B62-10. The value of resistor C53 (R1) is such that its voltage drop to current ratio is 1 to 10 (.1 volt drop equals 1 ampere of motor current). Difference amplifier B62-10 inverts this voltage, and presents the result to servo error input terminal 2 of amplifier B55-6. The two signals are summed at a ratio of 10 inputs to 1 feedback. It may be seen then that as current through the drive motor approaches the commanded level the output of B55-6 will diminish. When motor current matches command current, the Pulse Rev switch transistor F63 will be turned OFF. This removes motor current which removes feedback voltage and F63 is turned back ON again. The circuit will oscillate in this manner to maintain motor current at the commanded level.

Should the Power Monitor circuit detect an input voltage error, it will generate a -CAR. SERVO disable signal. This signal will turn transistor E77 ON which results in turning OFF Pulse Fwd and Pulse Rev transistors F47 and F63 to disable carriage servo movement.

4.7.2.2 Power Monitor Circuit

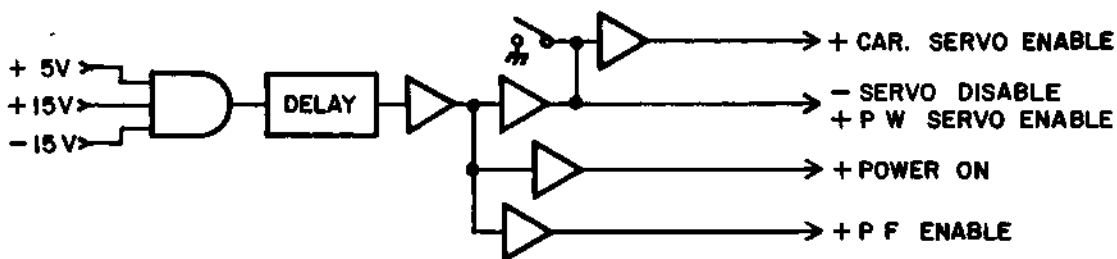

Figure 4-23 POWER MONITOR CIRCUIT BLOCK DIAGRAM

The purpose of this circuit is to inhibit paper feed, print wheel and carriage movement by generating a series of disabling signals anytime one or more of the three supply voltages drops below a level where

component damage might result. These signals also reset all printer program and logic circuits to their initial or zero condition (a restore sequence).

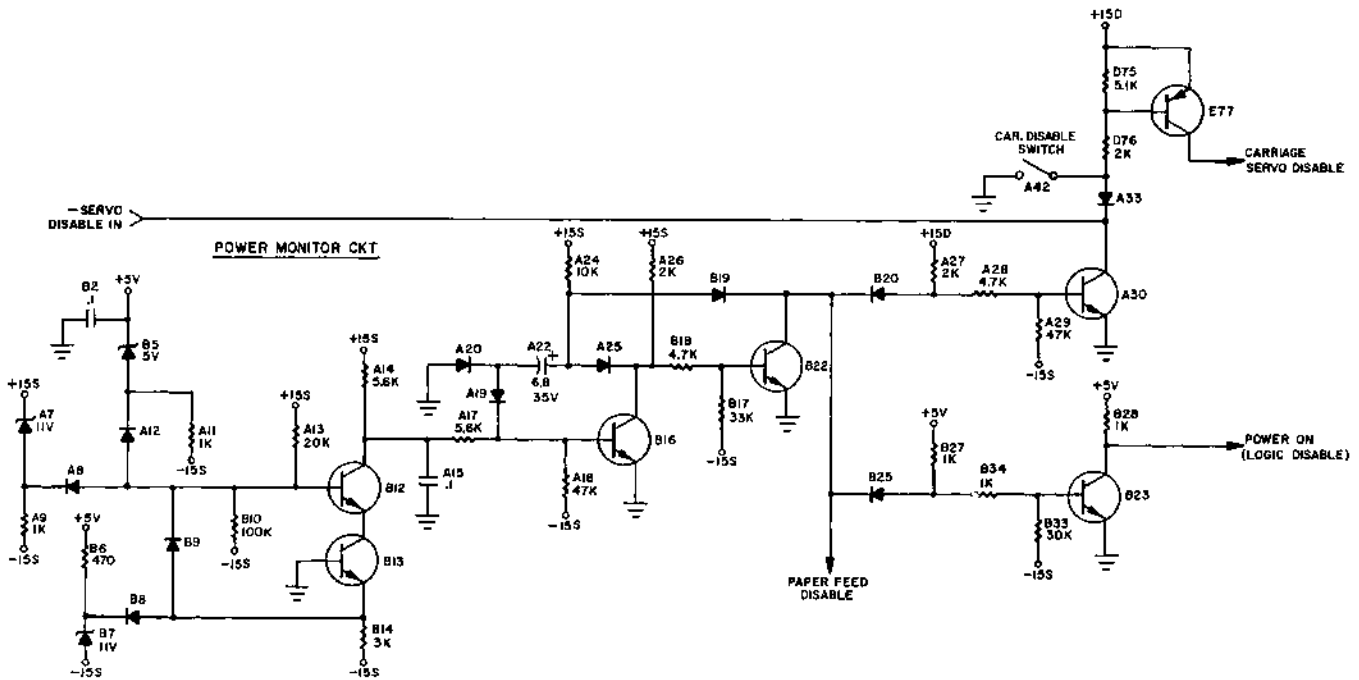

Figure 4-24 POWER MONITOR CIRCUIT

Refer to Figure 4-24. This circuit operates as follows. As power is applied, transistors B12 and B13 are OFF. Three divider networks begin to sample the +5, +15, and -15 volt levels being supplied: zener diode B5 and resistor A11 sample the +5 volt input; zener diode A7 and resistor A9 sample the +15 volt input; and zener diode B7 and resistor B6 sample the -15 volt input. As these voltages approach their appropriate values, diodes A8, A12, B8 and B9 (operating as an AND gate) are reverse biased, and transistors B12 and B13 turn ON. Up to this time transistor B16 had been ON and B22 OFF. When transistors B12 and B13 turn ON, capacitor A22 begins to charge through resistor A24 and the emitter base junction of B16, and transistor B22 is biased OFF. With transistor B22 OFF, transistors A30 and B23 along with two transistors C34 and C36 in the Paper Feed Drive circuit, are biased ON and their outputs are all clamped LO. This condition disables all printer functions as outlined and will continue until capacitor A22 has charged sufficiently to turn transistor B22 ON.

At the end of the delay (approximately 25 msec), transistor B22 is turned ON discharging capacitor A22 and turning transistor B16 OFF. It will also turn OFF transistors A30, B23, C34 and C36, allowing all their outputs to go HI. This removes the circuit disable clamps, starts the program counter in the microprocessor on Logic #2, and initiates a restore sequence.

Any subsequent interruption in, or depreciation of, any of the three input voltages monitored will disable the printer by action of this circuit. Complete restoration of power recycles this circuit, putting the printer back in operation with a restore sequence.

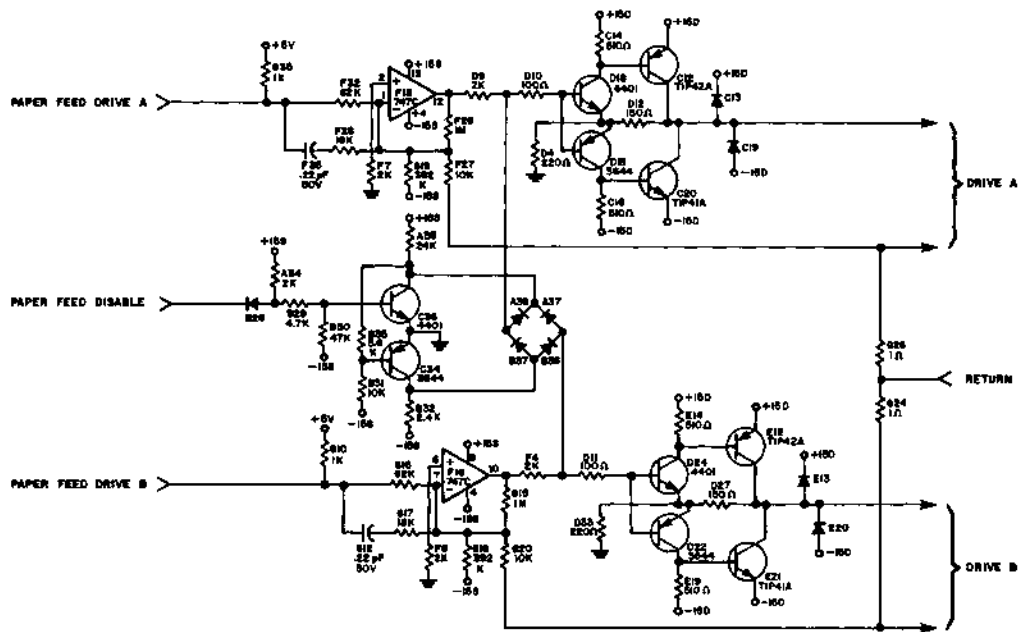
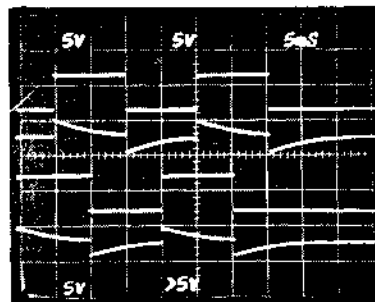
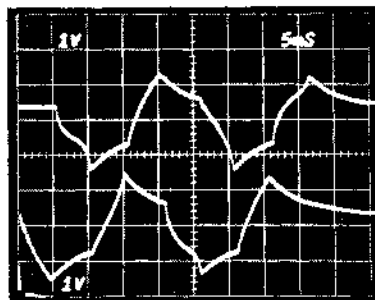

Figure 4-25 PAPER FEED DRIVE CIRCUIT



P F B
DIFF B (G12-G17)
P F A
DIFF A (F28-F35)



DRIVE B CURRENT
DETENT CURRENT
DRIVE A CURRENT

Figure 4-26 PAPER DRIVE WAVEFORMS

4.7.2.3 Paper Feed Drive Circuit

Figure 4-25 is a partial schematic diagram of the Paper Feed Drive circuit. Figure 4-26 shows waveforms taken in the circuit. The circuit consists of two identical channels A and B, each feeding a field winding in the paper feed stepper drive motor. As shown in Figure 4-26, the signals in channel A lead the signals in channel B by 90° . This relationship produces clockwise rotation of the stepper motor shaft (as viewed from its shaft end) for upward (forward) paper movement only. Since the A and B channels are identical, only channel B will be discussed here.

In operation, the square-wave PF B input on connector 10 is differentiated by a circuit consisting of capacitor G12, resistor G17, and resistor G20. This network provides a pulse to the input, pin 7, of operational amplifier F18-10 with a duration of approximately 4 to 5 msec. F18-10 squares and amplifies the input, with the result coupled to current amplifiers D22/24 - E12/21. The output drive current waveform (lower half of Figure 4-26) is applied to the B winding of the paper feed stepper drive motor (terminals T5 and T6).

The waveforms shown in Figure 4-26 represent one complete line feed operation. Examination of the waveforms will disclose four level changes for each channel, or a total of eight level changes per line feed. The stepper motor shaft moves 7.5° per level change (A or B) with the A to B 90° phase relationship controlling the direction of movement. Thus each line feed command produces $8 \times 7.5^\circ = 60^\circ$ of shaft rotation for a line spacing of six lines per inch.

The paper feed motor is detented electrically at the end of each line feed operation. Again, discussing channel B only, a circuit consisting of resistors G18, G16 and G10 (-15 volts to +5 volts) provides enough output from amplifier F18-10 (about .4 amp motor current) to electrically detent the stepper motor.

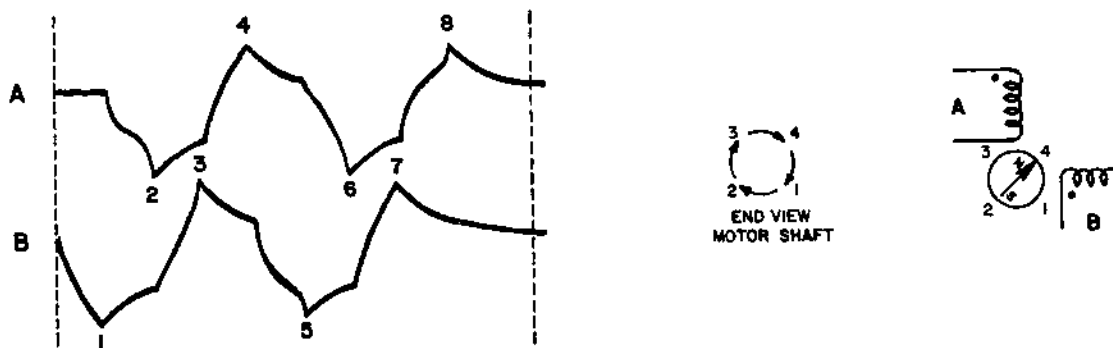

Figure 4-27 TYPICAL STEPPER MOTOR ROTATION

Figure 4-27 illustrates the development of stepper motor rotation from two inputs 90° out of phase with each other. Actually, the paper feed stepper motor's rotor has a magnetic node each 7.5° . This would be difficult to illustrate. It should be noted, therefore, that for clarity the illustration depicts a stepper rotor with magnetic nodes every 90° only.

4.7.3 Carriage Power Amplifier PCB Assy, ESD, #40525-11

This version of the circuit is designed for use in HyType II Printer Models 1345A and 1355WP with the ESD Option installed. It is electrically identical to #40525-10 discussed in subsection 4.7.2. This assembly adds a metal ground plane or shield between the circuit board and its heat sink.

4.7.4 Carriage Power Amplifier PCB Assy, 1355HS, #46025-05

This version of the circuit is designed for use in Model 1355HS HyType II Printers. It is identical to #40525-10 discussed in subsection 4.7.2 except as follows: Fusible resistors G37/G39 in the +/-15D power input circuits are replaced with jumper wires; Capacitor C15 is deleted in the Power Monitor circuit; and, Resistor C53 in the feedback instrumentation circuit is paralleled by resistor C56 with both at .2 Ohm 3W. Refer to Figure 7-6b Schematic Diagram.

4.7.5 Carriage Power Amplifier PCB Assy, 1355HS ESD, #46025-06

This version of the circuit is designed for use in Model 1355HS HyType II Printers with the ESD Option installed. It is electrically identical to #46025-05 discussed in subsection 4.7.4. This assembly adds a metal ground plane or shield between the circuit board and its heat sink.

4.8 PRINT WHEEL POWER AMPLIFIER PCB CIRCUITS

4.8.1 General Information

This assembly includes the Print Wheel Servo Power Amplifier, the Ribbon Lift and Ribbon Feed Drivers, the End Of Ribon sensor amplifier, and the Hammer Energy Control and Driver circuits. It is located in Printer Electronics Compartment Slot H, and has a finned heat sink attached to it, to help cool the several drive transistors.

NOTE: DO NOT stand the HyType II Printer on its rear heat sinks. These finned heat sinks are mounted on plug-in circuit boards which can be easily damaged by this practice.

4.8.2 Print Wheel Power Amplifier PCB Assy, Std., #40530-10

4.8.2.1 Print Wheel Power Amplifier Circuit

NOTE: This circuit is nearly identical to the Carriage Power Amplifier circuit described in subsection 4.7.

This circuit supplies and controls current flow to the print wheel servo drive motor. It is designed as an H bridge, allowing all current to flow through the motor from supply to supply instead of thru circuit ground to avoid circuit noise problems. Figure 4-21 illustrates the basic circuit in simplified form, where certain transistors in the actual circuit are represented as switches. It may be seen that closing switches S1 and S4 will cause current to flow through the motor and resistor R right to left, while closing switches S2 and S3 will cause current to flow left to right.

Referring to Figure 7-7a Schematic Diagram and the above will aid in understanding the operation of the circuit itself. Since the amplifier is composed of several similar circuits, only one path will be discussed.

Assume a PW SERVO ERROR signal input of +5 volts for a commanded motor current of 1 ampere. The output of operational amplifier A31-6 will be low, and this will place a low potential on the base of transistor H18 and on the emitter of transistor H35. H35 will turn OFF, turning transistor F32 OFF, which turns transistor E30 ON to turn ON Pulse Rev switching transistor G26.

The error signal is also supplied to amplifier A19-6. The output of amplifier A19-6 will be zero volt with a positive input, which will turn transistor C4 OFF. This will turn transistor D5 OFF and transistor E6 ON to turn ON Drive Rev switching transistor C10.

Referring to Figure 4-21, transistor C10 is shown as switch S1, while transistor G26 is shown as switch S4. Turning these two transistors ON establishes a current path from the -15 volt supply thru G26, resistor H32, the drive motor, and C10 to the +15 volt supply.

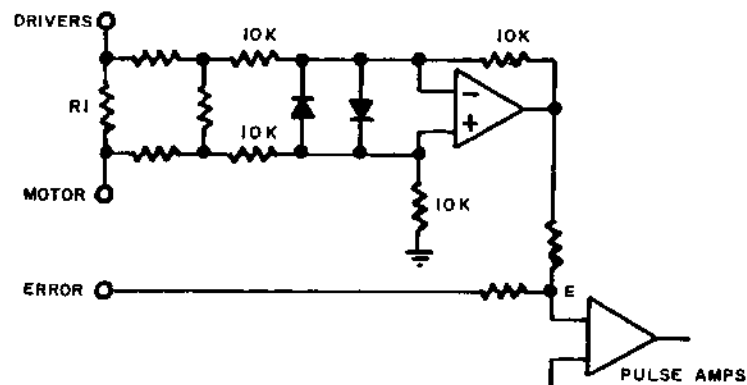

Figure 4-28 PRINT WHEEL FEEDBACK INSTRUMENTATION CIRCUIT

Figure 4-28 is a simplified schematic diagram of the feedback circuit. This circuit includes a .1 ohm resistor H23 (R1) located in one of the lines to the servo motor, across which is connected a precision balanced 10K Ohm resistor network and difference amplifier A45-12. The value of resistor H23 (R1) is such that its voltage drop to current ratio is two-to-one (a 2 volt drop equals 1 amp of motor current). Difference amplifier A45-12 inverts this voltage and presents the result to the servo error input terminal 2 of amplifier A31-6. The two signals are summed at a ratio of 10 inputs to 1.6 feedback, and it may be seen then that as motor current approaches the commanded level, the output of A31-6 will diminish. When motor current matches command current, the Pulse Rev switch transistor G26 will be turned OFF. This removes motor current, which removes feedback voltage and G26 is turned back ON again. The circuit will oscillate in this manner to maintain motor current at the commanded level.

Should the Power Monitor circuit detect an input voltage error, it will generate a -PW SERVO ENABLE signal. This signal will turn tran-

sistor E35 ON, turning OFF Pulse Fwd and Pulse Rev transistors G10 and G26 to disable print wheel movement.

4.8.2.2 Ribbon Lift Drive Circuit

This circuit consists of two subcircuits; one for ribbon lift and one for ribbon hold. The ribbon lift portion includes transistors G67 and H59. The RIBBON LIFT signal turns G67 ON to apply a ground potential to the base of H59. H59 turns ON, applying -15 volts to one side of the ribbon lift coil. The opposite side of the coil is tied to +15 volts. The coil is then energized with a potential of 30 volts, to provide maximum power to rapidly lift the ribbon. At the end of the ribbon lift sequence, the programmer removes the RIBBON LIFT signal and replaces it with the RIBBON HOLD signal. The ribbon hold portion of the circuit includes transistors H67 and H61. The RIBBON HOLD signal turns ON transistor H67 applying a ground potential to the base of H61. H61 turns ON, applying a ground potential to one side of the ribbon lift coil. The coil is then maintained in its energized state (ribbon lifted) with a potential of 15 volts.

4.8.2.3 Ribbon Feed Drive Circuit

NOTE: This circuit is nearly identical to the Paper Feed circuit described in subsection 4.7.2.3.

Refer to Figures 4-25, 4-26 and 4-27. The Ribbon Feed Drive circuit consists of two identical channels A and B. Figure 4-25 shows typical input and output waveforms for each channel for ribbon feed motor rotation.

The A and B inputs, 90° out of phase, are presented to type 747 operational amplifiers E74-12/-10 where they are squared and amplified. The output of these amplifiers is coupled to current amplifiers F48/D50 - D43/F45 for channel A, and F64/D64 - D58/E58 for channel B, where the drive for the ribbon feed stepper motor is developed.

The information in Figure 4-27 further illustrates the development of the stepper motor rotation from the two out-of-phase inputs. It should be noted, however, that unlike the paper feed operation, ribbon feed is in one direction only, with the controller providing the information for ribbon feed.

On the Model 1355WP Word Processor Printer, the ribbon advance stepper motor increments in 30° steps rather than 90° steps. This aids in achieving true proportional ribbon advance.

4.8.2.4 Hammer Energy Control and Drive Circuit

Refer to Figures 4-29 and 7-7 Schematic Diagram.

Figure 4-29 is a simplified schematic diagram of the Hammer Energy Control circuit. The HAMMER ENERGY CONTROL signal from the D-A Converter on the SERVO PCB is the input to this circuit. This is the signal whose instantaneous level depends on the character to be printed. The normal range of this signal is 0 to +10 volts. Direct Controller access to exercise closer control of this level is discussed in Section 6.

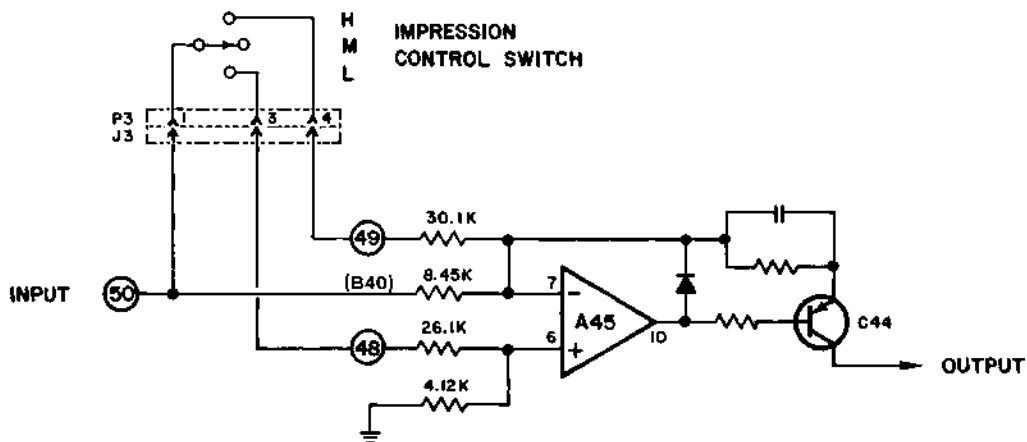

Figure 4-29 HAMMER ENERGY CONTROL CIRCUIT

The input is applied to Terminal 50. From this point, it goes through resistor B40 to pin 7 of amplifier A45-10, and to the wiper arm of the Operator's Impression Control Switch. The output of the amplifier is then dependent on the position of this switch, i.e. whether a portion of the input is added to or subtracted from the input.

The +FIRE HAMMER pulse from the Programmer on Logic #2 PCB turns transistor H50 OFF, to drive the hammer enabling circuits. The hammer fire pulse from H50 is compared with the hammer energy level in comparator A64-7, and also enables transistor C65. C65's output switches driver transistor C73, and also establishes its output level to control the amount of current flowing to the hammer coil.

4.8.3 Print Wheel Power Amplifier PCB Assy, ESD, #40530-11

This version of the circuit is designed for use in Model 1345A HyType II Printers with the ESD Option installed. It is electrically identical to #40530-10 discussed in subsection 4.8.2. This assembly adds a metal ground plane or shield between the circuit board and its heat sink.

4.8.4 Print Wheel Power Amplifier PCB Assy, 1355 Std, #40730-10

This version of the circuit is designed for use in HyType II Printer Models 1355HS and 1355WP. It is electrically identical to #40530-10 discussed in subsection 4.8.2 with the following exceptions: .1 Ohm 3W Resistor G23 added in series with Resistor H23 in the feedback instrumentation circuit; R-C network B29/B30 plus capacitor D31 added to the Pulse circuit; R-C networks and a capacitor added to the Ribbon Feed Drive circuits; and, Component changes at B39/B40/C41 and C55, and zener diode F55 deleted in the Hammer Drive circuit. Refer to Figure 7-7b Schematic Diagram.

4.8.5 Print Wheel Power Amplifier PCB Assy, 1355 ESD, #40730-11

This version of the circuit is designed for use in HyType II Printer Models 1355HS and 1355WP with the ESD Option installed. It is electrically identical to #40730-10 discussed in subsection 4.8.4. This assembly adds a metal ground plane or shield between the circuit board and its heat sink.

4.9 INTERNAL POWER SUPPLY OPTIONS

4.9.1 General Information

Several versions of the Internal Power Supply are currently available for installation in Series 1300 HyType II Printers. These various supplies are discussed individually in the following subsections.

CAUTION: A word of CAUTION for those technicians who may not be familiar with the higher voltage levels found in switching power supplies.

Experiments have shown that +/-18 volts at .25 Amp can KILL if the conditions are right!

WARNING: The Internal Power Supplies discussed herein use voltage levels which can be LETHAL!

4.9.2 Internal Power Supply Assy, DP, #24250-XX

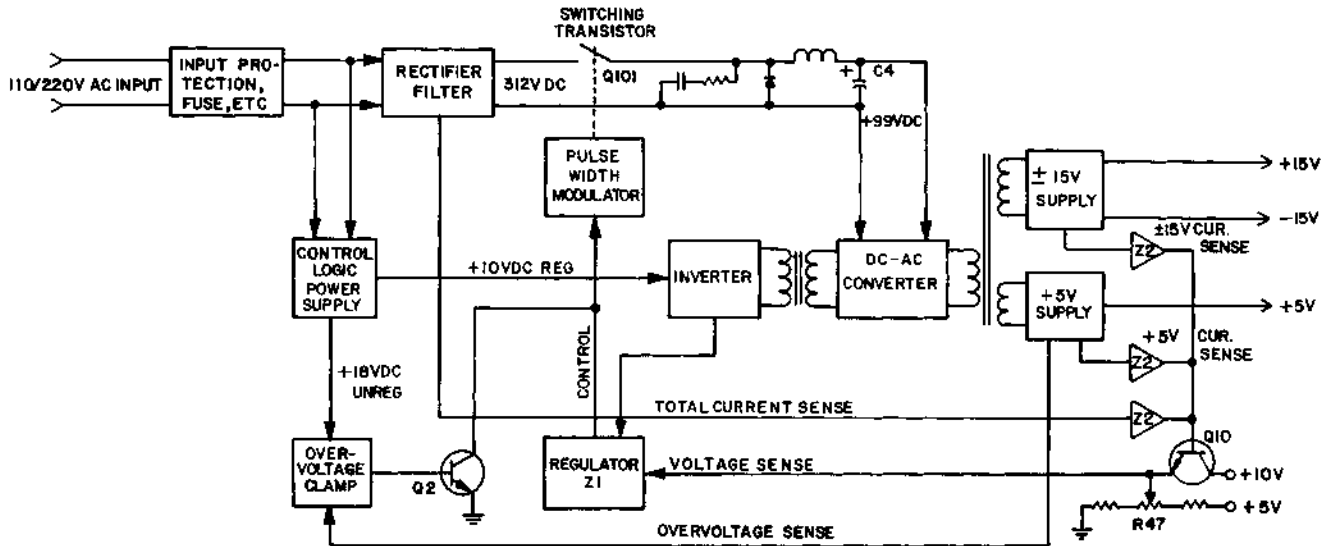

Figure 4-30 OPTIONAL INTERNAL POWER SUPPLY BLOCK DIAGRAM (DP)

Refer to Figure 4-30 above, and to Figure 7-8a Schematic Diagram.

This optional Internal Power Supply is a direct line switching circuit which operates as follows. The 115/230 volt AC input (domestic version) passes a line fuse, a line filter network, and transient/surge protection devices. From that point, the filtered AC is applied to a high voltage (312 volts DC) rectifier and filter circuit, and to a low voltage (+10 volts regulated and +18 volts unregulated DC) power supply. The high voltage rectifier and filter circuit also includes transformer T7 which is used to sense total current flow through the high voltage network.

The output of the high voltage rectifier and filter is applied to the emitter of switching transistor Q101. Current flows through the transistor and choke L101 to charge capacitor C4. As C4 charges, the

voltage level coupled to the DC-AC converter circuit rises. Power is also being applied to the inverter circuit from the low voltage supply, and the inverter begins to oscillate at approximately 20 kHz. The inverter's output is coupled to the DC-AC converter through transformer T2. The converter's output is the level of charge on capacitor C4 being switched at the inverter frequency and applied to the primary winding of transformer T3. The several power supply output voltages are then developed in the T3 secondary windings, rectified, filtered, and presented to the power supply's output terminals.

Each low voltage output supply includes a current sensing transformer similar to T7 in the high voltage circuit. These are T4 for the +15 volt, T5 for the -15 volt, and T6 for the +5 volt circuits. The secondary winding of each of these current sensing transformers (T4 thru T7) is connected to a comparator, part of module Z2. The output of each comparator is diode OR'ed to the base of overcurrent switching transistor Q10. The emitter of Q10 is tied to +10 volts DC, while the collector goes to pin 4 of switching regulator Z1. The output of a voltage divider network (R46, R47 and R48) is also tied to Z1 pin 4, and is used to set the operating conditions for the circuit. The line to Z1 pin 4 is then the voltage sense input to the regulator. Transistor Q8 supplies a reference level to Z1 pin 5 of about +3.46 volts which carries a +/-75 mv sawtooth component obtained from the inverter through winding 7-8 of transformer T2. The output of Z1 at pin 9 is coupled to transistors Q1 and Q3 which, with transformer T1, forms a pulse width modulator (PWM) circuit to turn transistor Q101 on and off at the inverter frequency. The energy output from the supply is drawn from capacitor C4. Transistor Q101 is turned ON to keep C4 charged. A higher current demand in one or more of the output circuits works through the sense circuits, the regulator, and the PWM circuit to keep Q101 in its ON state longer during each cycle to provide an increased current supply to capacitor C4. A lower current demand works in reverse of this to keep Q101 ON for a shorter period each cycle providing less energy to C4 in keeping with the need.

A dramatic increase in current demand in one or more of the output circuits will work to greatly reduce the output of Q101, keeping the available current at a safe level.

An overvoltage detection circuit is included in the power supply and is tied to the +5 volt supply. The major circuit components are zener diode CR13, transistor Q9, SCR CR12, SCR CR6, and transistors Q7 and Q2. A rise in the +5 volt level exceeding +5.2 volts will break down zener diode CR13 turning transistor Q9 ON. This will gate SCR CR12 ON to short circuit the +5 volt line to ground, and will also gate SCR CR6, located in the overvoltage clamp circuit. When gated, CR6 turns transistors Q7 and Q2 ON. This chain action works to turn switching transistor Q101 OFF. As the voltage level of the +5 volt supply line falls, Q9 will turn OFF, the circuits will reverse themselves to turn Q101 ON again. As long as the output circuit problem exists, the power supply control logic will oscillate in this manner, maintaining a very low charge level on capacitor C4 and a very low output level on all supply lines.

This type of protection circuitry has two advantages. One, the supply will recover immediately from a fault condition once the overload has

been removed, and two, the low voltage level which is maintained on all lines during a fault condition aids in locating the problem.

Use ALL CAUTION when working with the higher voltages found in these power supplies! These voltages are significantly HIGHER than those normally associated with TTL/MOS devices. Capacitors C2 and C3 (156 volts each!) are discharged SLOWLY through bleeder resistors R2 and R3. These capacitors should be discharged completely by shorting them to ground before starting work on the supply.

4.9.3 Internal Power Supply Assy, B, #26021-XX

4.9.3.1 General Information

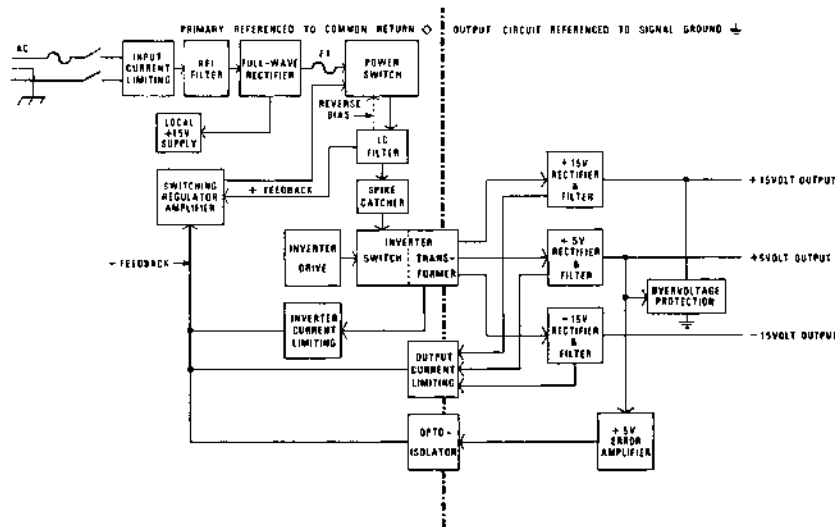

Figure 4-31 OPTIONAL INTERNAL POWER SUPPLY BLOCK DIAGRAM (B)

Refer to Figure 4-31 above, and to Figure 7-8b Schematic Diagram.

This optional Internal Power Supply is also a direct line switching circuit, and operates as follows. The 115/230 volt 50/60 Hz AC input (domestic version) passes thru line transient/surge protection and filtering circuits, and is applied to a full wave bridge rectifier circuit. The dc output of approximately 100 volts from the rectifier passes fuse F1 and is supplied thru a resistor network to a local +15 volt regulated power supply circuit, and to the high voltage primary power supply circuit.

4.9.3.2 Input Surge Limit and Filter Circuits

When ac power is initially applied, filter capacitor C23 demands a high rate of charging current. To protect the diodes in the rectifier, thermistor RT1 is inserted in the line. This resistor has a negative temperature coefficient and initially offers a relatively high resistance value, which then lowers as its internal temperature rises due to current flowing thru it. This sequence limits the charge rate for C23. Eventually, the resistance of RT1 drops to a very low level, where the ac ripple component from the rectifier is sufficient to keep its temperature up and resistance down.

Switching power supplies tend to generate sharp transients, which can be reflected back on to the power line. Line filter capacitors C1, C2 and C4, and RFI filter inductor L1 suppress this tendency. L1 is a device with two windings on a common magnetic core. This design develops a higher Q and provides better filtering than two single RF chokes.

4.9.3.3 Full Wave Bridge Rectifier and Local +15 Volt Supply

The full wave bridge rectifier CR1 thru CR4 converts the line ac voltage to dc. Capacitor C23 provides filtering and storage of the rectified dc. The cathode of C23 defines the primary circuit common return. Note that the rectifier is returned to the primary circuit common return and NOT to signal ground. Fuse F1 protects the bridge diodes in the event of a component failure in the primary circuit. The output is applied to both the local +15 volt supply and to power switch Q1.

The local +15 volt circuit furnishes power to the primary circuit. Zener diode VR1 and resistors R12, R13 and R14 provide a reference voltage that is compared to a sampled voltage by transistor Q5. The error signal developed is used to control transistor Q6, the series-pass element, to produce the desired regulation.

4.9.3.4 Power Switch and Switching Regulator Amplifier

Power transistor Q1, the power switch, is controlled by Type 723 switching regulator amplifier U1, thru a chain of power-boosting transistors. The switching signal generated within U1 at approximately 20 kHz turns the power switch on and off. Regulation is affected by modifying the duty cycle of the switch in response to feedback signals from the +5 volt output. Low output voltage results in increasing "on" time; with high output voltage causing a reduction in "on" time. Modifying the duty cycle raises or lowers the average voltage delivered to the inverter.

The output of U1 is boosted by transistor Q7 to drive complementary Darlington stage Q3. Q3 in turn drives Darlington-connected Q2, the immediate driver stage for power switch Q1. The 20 kHz chopped dc output from the switch is applied to an LC filter for smoothing. The switch output signal is fed back to pin 4 of U1 via inductor L2 and resistors R27 and R17 to maintain self-oscillation. To overcome the effect of charge storage, reverse emitter-base bias is injected into the power switch from a secondary winding on L2. The reverse bias signal is applied via a network of resistors R2, R3 and R5, capacitor C5, and diode CR5. The phasing of the secondary of L2 causes a pulse of turn-off bias to be applied to both Q1 and Q2 at the termination of the switch "on" period. Turnoff of the switch becomes regenerative, and is greatly accelerated.

4.9.3.5 LC Smoothing Filter and Spike Catcher

The regulated pulsed dc is applied to a filter network made up of inductor L2 and capacitor C10. Diode CR6 maintains output current flow during switch "off" periods by providing a current path to discharge the energy stored in the magnetic field of the inductor during "on"

periods. CR6 is reverse-biased when the power switch is "on" to prevent upsetting dc conditions. The smoothed and regulated dc output of the filter is applied to the inverter via a "spike catcher" network.

This network consists of diode CR10, resistors R29 and R48, and capacitor C11. The purpose of this circuit is to suppress large current spikes that can be generated when conduction of the two inverter transistors overlaps. This is not a common occurrence, but can happen during start-up or during recovery from an overload condition. This suppression not only reduces RFI radiation, but also protects the inverter transistors and the power switch transistor. Diode CR10 is polarized to damp production of counter emf should transients occur in the inverter.

4.9.3.6 The Inverter

The smoothed dc input is chopped at 20 kHz by the two power transistors Q10 and Q11 conducting alternately. They feed current to the two halves of the primary winding 1-2-3 of the nonsaturating output transformer T1 in opposite directions. Supporting circuitry consists of a saturating transformer T2, diodes CR11 thru CR15, resistors R29 thru R32, and capacitor C12. The transformer is a self-excited type.

4.9.3.7 DC Output Circuits

Each dc output has its own full-wave center-tapped rectifier and low pass filter. In addition, high-frequency ripple (mostly 40 kHz) is filtered out of the +/-15 volt outputs by capacitors C32 and C33. The rectifier for the +15 volt supply is made up of transformer T6, diodes CR17 and CR22, and capacitors C35 and C38. Inductor L4 and capacitor C18 provide filtering. The -15 volt supply uses transformer T5, diodes CR18 and CR21, and capacitors C36 and C37. Filtering is provided by inductor L6 and capacitor C20. The +5 volt supply uses transformer T4, diodes CR19 and CR20, and capacitors C39 and C43. Filtering is provided by L5 and capacitors C19 and C25. R54 is the +5 volt bleeder resistor. Filter capacitors C32 and C33 are discharged when required by bleeder resistor R51.

4.9.3.8 +5 Volt Error Amplifier

The +5 volt output is sampled by voltage divider resistors R43 and R44, and applied to the noninverting input of Type 723 voltage regulator U2 via resistor R41. The adjustable reference voltage is derived from potentiometer R40 and applied to the inverting input of the voltage regulator via resistors R39 and R38. The two voltages are compared within U2 and the difference is applied to the optoisolator U3. Only the +5 volt output is adjustable and regulated. The close electromagnetic coupling in the transformer secondary of T1 makes it possible to control all output voltages by controlling any one.

4.9.3.9 Current Limiting and Overvoltage Protection

The optoisolator U3 consists of a solid-state lamp and a phototransistor. The output of the error amplifier is applied to the lamp, illuminating it in proportion to the error. The optical energy is read by the phototransistor, which has no electrical connection to its

base. The output of the phototransistor is fed back thru resistor R33 to the switching regulator amplifier U1 where the signal is used to modify the duty cycle of the power switch, and thereby regulating the voltage. Since there is no direct electrical connection thru this device, and the phototransistor output is returned to the primary circuit common return, the output circuit is effectively isolated from the primary.

Current flow in each output passes thru a toroidal transformer where it is monitored and fed back to the switching regulator transformer to modify the switch duty cycle. Resistor R58 is connected across a winding of transformer T4 in the +5 volt circuit. Current thru the transformer develops a voltage drop across the resistor. Transistors Q14 and Q15 sense and amplify the voltage drop. In the -15 volt supply, resistor R59 is across the winding of T5, and transistors Q16 and Q17 are the sense amplifiers. In the +15 volt output circuit, the elements are transformer T6, resistor R60, and transistors Q18 and Q19. The collectors of all the transistors are connected to the base of transistor Q13 thru resistor R70. Q13 amplifies the error signal, which can originate in any of the outputs, and applies it to the switching regulator amplifier along with the voltage regulation feedback signal. As current increases, the duty cycle of the switch regulator, and of the power switch, is modified to reduce switch "on" time reducing the average voltage applied to the inverter which limits current thru the inverter transformer. A shorted output will reduce current to a very low level which can be tolerated indefinitely.

Overvoltage protection is provided primarily to protect the loads in the event of failure of the regulating circuit. Silicon controlled rectifier SCR1 is connected across the +15 volt output. The gate of SCR1 monitors the +5 volt output thru zener diode VR2 which has a 5.6 volt breakdown rating. If the +5 volt supply exceeds the zener's breakdown voltage VR2 conducts, placing a direct short across the +15 volt output. In effect, this "crowbars" all outputs because of the close coupling of the inverter transformer secondary. To protect the power supply, the current limiting circuit takes over, reducing the power switch output to a safe level. Once fired, the SCR will continue conducting until power is turned off. When the condition causing the overvoltage condition is corrected and power applied the protect circuit is automatically restored to normal.

4.9.4 Internal Power Supply Assy, U, #301155-XX

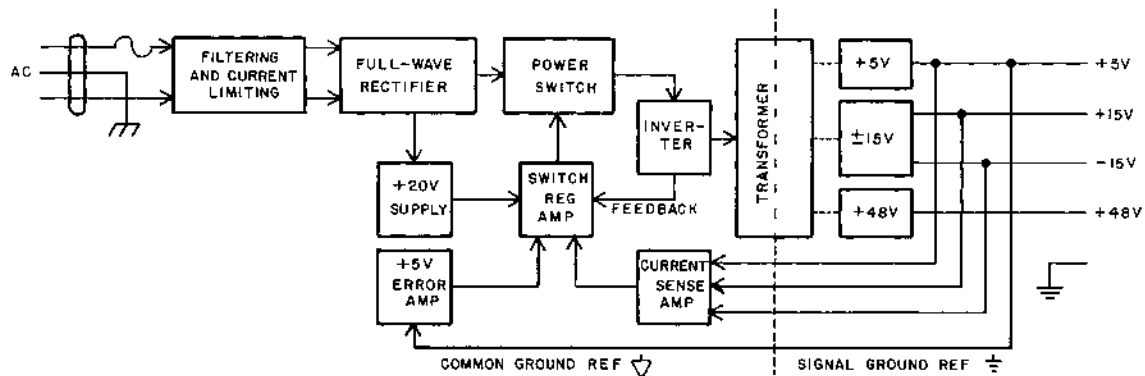

Figure 4-32 OPTIONAL INTERNAL POWER SUPPLY BLOCK DIAGRAM (U)

4.9.4.1 General Information

Refer to Figure 4-31, and to Figure 7-8c Schematic Diagram.

This optional Internal Power Supply is a direct line switching type. In operation, the ac input is rectified and filtered. It is then applied to an inverter circuit which produces the "ac" needed for transformer action. The secondary windings of the power transformer then produce the several output voltages of +5, +/-15 and +48 volts. The +5 and +/-15 volt outputs are sensed for current flow and the +5 volt supply is sensed for voltage level. These signals are used as feedback to regulation amplifiers which in turn control the power switching transistor.

AC input to this power supply is acceptable within the following limits:

90-130/180-260 VAC 47-63 Hz

Selection of the input power range is by jumper plug B-1/-2 on the main power supply circuit board.

4.9.4.2 Input Surge Limit and Filter Circuit

The ac input passes a line fuse, a line filter network, and surge protection devices. These devices are located on a separate circuit board which also anchors the ac input line cord. The surge protection components prevent destructive inrush current following application of power. Switching power supplies tend to generate sharp transients which can be reflected back on to the input power line. The line filter on this board, plus capacitors A1, A2 and A3 on the main main circuit board are used to suppress these transients.

4.9.4.3 Full Wave Bridge Rectifier and Local +20 Volt Supply

A full wave bridge rectifier (diodes B1 thru B4) converts the line ac input to a pulsating dc smoothed by filter capacitors A5, A25 and C16. Resistors C3, C4 and C7, 20 volt zener diode C2, and transistor C5 produce a regulated +20 volt dc source for use by the switching regulator circuits.

4.9.4.4 Power Switch and Switching Regulator Amplifiers

Power switch transistor C35 is controlled by switching regulator amplifier B30 thru a network composed of transistors C9, C21, C23, C30 and their associated components. Regulation amplifier B30 operates to turn switch C35 on and off to maintain a charge on capacitor B50 which supplies power to the inverter circuit. Regulation of the supply output is affected by monitoring several outputs (+5 volt and +/-15 volt) and using the results to modify the power switch transistor's on/off duty cycle. All three are monitored for current flow, while the +5 volt supply is also monitored for voltage level. The +5 volt level is adjustable using potentiometer A71 which controls regulation amplifier A67 which in turn controls amplifier B30 thru opto-isolator B36. Thus the +5 volt output is used to control the levels of all the outputs from the supply. Close transformer coupling allows the +/-15 volt and +48 volt circuits to reflect their condition back to the +5 volt supply and ultimate power switch regulation. Excessive current flow

in any output will be sensed and the action of the power switch adjusted accordingly. A short circuit failure will cause the output to be reduced to a minimum level until the problem is corrected.

4.9.4.5 LC Smoothing Filter and Spike Catcher

The regulated pulsed dc output of power switch C35 is applied to a filter network made up of inductor A40 and capacitor B50. Diode B39 maintains output current flow during switch C35 "off" periods by providing a discharge path for inductor A40's magnetic field current stored during "on" periods. Diode B39 is reverse biased during "on" times. The smoothed and regulated dc output is applied to the inverter circuit via a "spike catcher" network.

The "spike catcher" network consists of inductor A52, resistor A26 and capacitor B50. This circuit suppresses any large current spikes which might be generated should conduction of the two inverter transistors overlap. Diode A55 damps counter emf in inductor A52.

4.9.4.6 The Inverter

The smoothed dc is chopped at a 20 MHz rate by the two transistors C52 and C64 conducting alternately. They feed current to the primary winding of nonsaturating output transformer B70 supported by saturating transformer B57 and its associated components.

4.9.4.7 DC Output Circuits

Each of the four dc outputs makes use of a center tap secondary winding of transformer B70, and a rectifier/filter network. In addition, the +/-15 volt circuits have noise filters and toroidal current sensing transformers while the +5 volt circuit includes the current transformer and a voltage regulator circuit.

Current flow in each output is sensed thru the toroidal transformers and the results are fed back thru an R-C Diode network to transistor B12-6 to the switching regulator amplifier B30. The +5 volt output level is also sent to the overvoltage regulating amplifier A67.

Due to the close transformer coupling mentioned earlier, the +48 volt output (not used in Series 1300 HyType II Printers) does not require output monitoring.

4.10 SPLIT PLATEN OPTION

This option is designed for use with all models of the Series 1300 HyType II Printer, except the Model 1345A Systems configuration which deletes the Motherboard PCB connector for the Option PCB. Note also that this option cannot be installed on any machine which has the optional internal power supply installed, or has a custom PCB installed in the Option Slot.

Refer to subsection 4.7.2.3 Paper Feed Drive Circuit, and to Figure 7-9 Schematic Diagram #40617-02.

The circuits included here are much like the Paper Feed Drive circuits found on the Carriage Power Amplifier PCB. The Logic #2 microprocessor provides two phased square waves to the inputs OP/C2 and OP/C3. These inputs are phase related to control the direction of optional (left-hand) paper feed motor rotation. The inputs are differentiated in an R-C network and applied as pulses to an operational amplifier and a network of inverting and current amplifiers. The output current waveforms are then applied to the windings of the paper feed stepper motor as a drive signal. A negative feedback circuit prevents the development of excessive drive current.

SECTION 5

MAINTENANCE

5.1 GENERAL DISCUSSION

The limited number of moving parts within the HyType II Printer simplifies troubleshooting and minimizes maintenance and repair time.

Replacement of the printer, to shorten downtime in the event of a malfunction, is made practical by the unit's light weight and low cost.

When unit replacement is impractical, subassembly replacement is a ready alternative. The subassemblies recommended as part of a normal spares inventory, are listed in subsection 5.2. These are directly interchangeable, requiring no more than a minor adjustment or two in most cases to complete the installation. Extensive component replacement or mechanical adjustments are normally attempted only in a service depot or factory environment.

5.1.1 Maintenance Requirements

The reduced reliance on mechanical devices decreases normal preventive maintenance to surface cleaning and lubrication, and a visual check of the printer's mechanical features, as outlined in subsection 5.3.3 Cleaning and Inspection. Higher level maintenance and adjustment procedures are discussed in subsection 5.4 Corrective Maintenance.

5.1.2 Maintenance Instructions

The HyType II user should study subsection 5.2 below, compare that information with his existing or intended facilities and capabilities, and determine the maintenance level he intends to sustain. Spares provisioning and test equipment assignment may then be accomplished economically.

5.1.3 Maintenance Precautions

Avoid damage to the HyType II Printer. Observe the following precautions during service and maintenance activity:

1. Never remove or install any circuit board, or connect or disconnect any plug or cable while power is on.
2. Applying power to the printer initiates a RESTORE sequence which includes movement of the carriage. Make sure the carriage is free to move LEFT before applying power.
3. DO NOT stand the HyType II Printer on its rear heat sinks. The finned heat sinks are mounted on plug-in circuit boards which can be easily damaged by this practice.
4. Do not use alcohol to clean the platen or the paper feed rollers. Alcohol hardens rubber, resulting eventually in paper feed problems. Use Fedron Platen Cleaner or its equivalent.

CAUTION:

Fedron Platen Cleaner and similar products are flammable and have a very low flash point!

5. Do not use platen cleaner to clean plastic parts. These products are usually harmful to plastics, and may cause damage. Clean plastics with alcohol.
6. The print wheel does not need cleaning under normal operating conditions. Slight ink buildup is normal, especially with a new ribbon. Such ink deposits are partially returned to the ribbon as its ink content diminishes in use. Only unusually severe operating conditions will make print wheel cleaning necessary. When needed, clean the print wheel with alcohol.

5.2 MAINTENANCE LEVELS, TOOLS, EQUIPMENT AND SPARES

5.2.1 Levels of Maintenance

Preventive maintenance on the HyType II Printer is simple and easily accomplished by the user. Corrective maintenance, however, requires a minimum level of technical expertise and facility in practice, and capability in this area will vary greatly from user to user. Consequently, the maintenance procedures described herein are divided into three categories, or levels. The first level is preventive maintenance and may be accomplished by any user. The second level is corrective maintenance involving on-site exchange of printed circuit boards and subassemblies, and minor adjustments. The third level, also corrective in nature, involves depot and/or factory repair or refurbishment of assemblies and printed circuit boards.

5.2.1.1 Level 1 - Ribbon cartridge and print wheel change; surface cleaning and lubrication; adjustment of print impression and platen position controls; and minor assembly exchanges of platens and paper cradle.

5.2.1.2 Level 2 - Level 1 items, plus unit replacement, PCB exchange, subassembly replacement, and minor adjustment and alignments.

5.2.1.3 Level 3 - Levels 1 and 2, plus major disassembly and refurbishment of subassemblies, and repair of PCB's.

5.2.2 Preventive Maintenance Items - Level 1

The following listed items should be available to persons operating and/or servicing the HyType II Printer on a regular basis:

1. Fedron Platen Cleaner, or equivalent
2. Lint Free wipers
3. No. 70243 light oil
4. No. 70654 Polyoil (light white grease) 8cc
5. No. 70825-01 Multipurpose grease, 2oz tube
6. No. 99000-01 Alcohol Pads (91% Isopropyl alcohol) or equivalent
7. No. 70870-02 Adhesive, 1 cc
8. Clean, low pressure compressed air (optional)

CAUTION:

1. Observe all OSHA safety rules for use of compressed air, including safety goggles.
2. Do not use alcohol on rubber items.

3. Do not use platen cleaners on plastic items.
4. Use platen cleaners and alcohol with care. Alcohol and most platen cleaners are VERY flammable (low flash point, volatile, etc.).

5.2.3 Corrective Maintenance Items - Levels 1 and 2

The items listed above for Level 1, plus the following, should be available to persons involved in corrective maintenance and/or repair of the HyType II Printer at the second level:

1. One set of PC boards
2. One Platen (appropriate type)
3. One Carriage Assembly
4. One Carrier Assembly, complete with paper feed motor
5. One Carriage Drive Motor
6. One Carriage Drive Cable Assembly
7. One Forms Tractor Assembly, if appropriate
8. Assortment of Hand Tools adequate for electronic/mechanical repair, including a T-handle spring tool (Diablo No. 99009) and a long nose self locking clamp (Hemostat, Diablo No. 16424)
9. TORX Tools -

Driver Bit	#T15	Diablo No.	70826-01
Driver Bit	#T9	Diablo No.	70826-02
Screwdriver	#T15	Diablo No.	70826-03
Screwdriver	#T9	Diablo No.	70826-04
Key Wrench	#T15	Diablo No.	70826-05
Key Wrench	#T9	Diablo No.	70826-06
10. Connector Extractor, 3M #3438, Diablo No. 70832
11. Print Wheel Adjustment Tools, Diablo No's 40795, 40795-02, 40796, and 301445-01
12. Tensiometer, Electromatic Equipment Co. Model DXE-1KD or equivalent, calibrated for Diablo cable
13. Cable Ties, Diablo No. 10538-01
14. Thermal Compound, Diablo No. 10549

5.2.4 Corrective Maintenance Items - Levels 1, 2 and 3

The items listed above for Levels 1 and 2, plus those listed below should be available to persons involved in corrective maintenance and/or repair of the HyType II Printer at the third level:

1. One PCB Extender Assembly, Diablo No. 40539-03
2. One Carriage Motor Extender Cable Assembly, Diablo No. 40667
3. One Transducer Extender Cable Assembly, Diablo No. 40666
4. One Print Wheel Motor with appropriate hub assembly
5. One Paper Feed Motor
6. Oscilloscope, vbw 15 MHz, vds 100 mV/cm, sweep speed 50 ns/cm
7. Model 500 Programmable Tester Assembly, Diablo No. 20900-XX

5.3 PREVENTIVE MAINTENANCE - MAINTENANCE LEVEL 1

5.3.1 Preventive Maintenance Philosophy

The principle of maximum machine availability governs the preventive maintenance recommendations contained herein. Unless a procedure in-

creases machine availability or enhances operation, it is not recommended. Except for the procedures outlined, no maintenance or adjustment should be performed on a printer that is operating properly.

5.3.2 Preventive Maintenance Procedures

The recommended preventive maintenance is normal cleaning and inspection every 6 months or each 500 hours of operation, whichever occurs first. The machine will require a visual inspection, cleaning, and minimal lubrication at this time. Normal time required for this procedure should not exceed 15 minutes.

5.3.3 Cleaning and Inspection

1. Remove power from the printer. Open and remove covers as required to gain access to the printer mechanisms.
2. Thoroughly inspect the printer for signs of wear and loose or broken hardware. Check the platen for looseness or wobble. Check the carriage system for looseness, wobble, or accumulations of foreign material on the rails which might cause uneven carriage movement. Check the carriage drive cable system carefully for signs of wear.
3. Remove the platen, paper cradle, ribbon cartridge, and print wheel. Inspect these for signs of wear.
4. Clean the printer thoroughly, using alcohol saturated cleaning pads and wipers. Remove accumulations of paper residue, ink, dust, etc., with special attention to carriage rails and pulley grooves. Heavy deposits may be first removed by blowing with compressed air. Be sure to observe all safety precautions when using compressed air.

NOTE: Use of compressed air is NOT recommended when the printer is located close to other equipment sensitive to dirt and dust.

5. Clean the platen, platen pressure rollers, and paper bail rollers with a good platen cleaner which is noninjurious to rubber products, such as Fedron Platen Cleaner. Do not use alcohol on these items.

5.3.4 Lubrication

Lubricate the various parts of the cleaned and inspected printer according to the following schedule. DO NOT exceed this schedule. Too much lubricant is often worse than none at all.

5.3.4.1 Carriage System

Refer to Figures 5-1 and 5-2.

1. Carriage Rails (A) - Clean these with alcohol pads.
2. Carriage Rail Bearings (B) - Put 4 to 5 drops of light oil on each rail on each side of the carriage, and move the carriage back and forth slowly by hand allowing the oil to saturate the lubrication felts inside each carriage bearing.

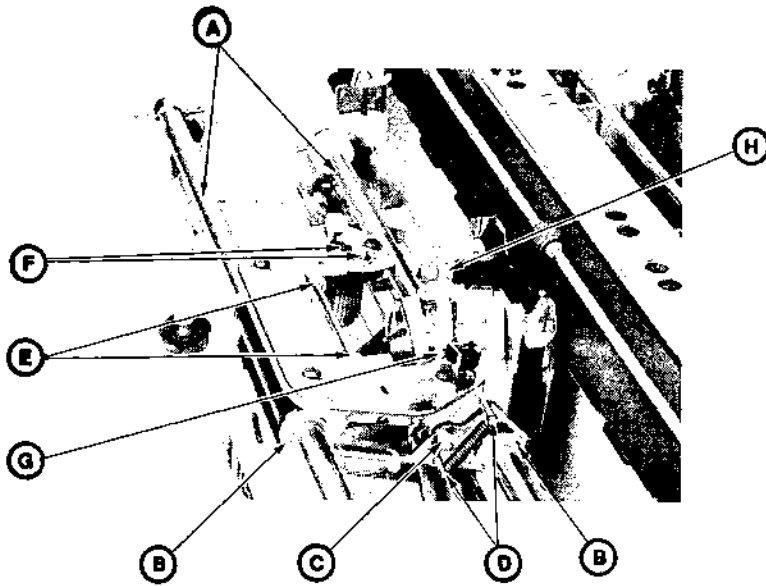

Figure 5-1 CARRIAGE SYSTEM LUBRICATION POINTS

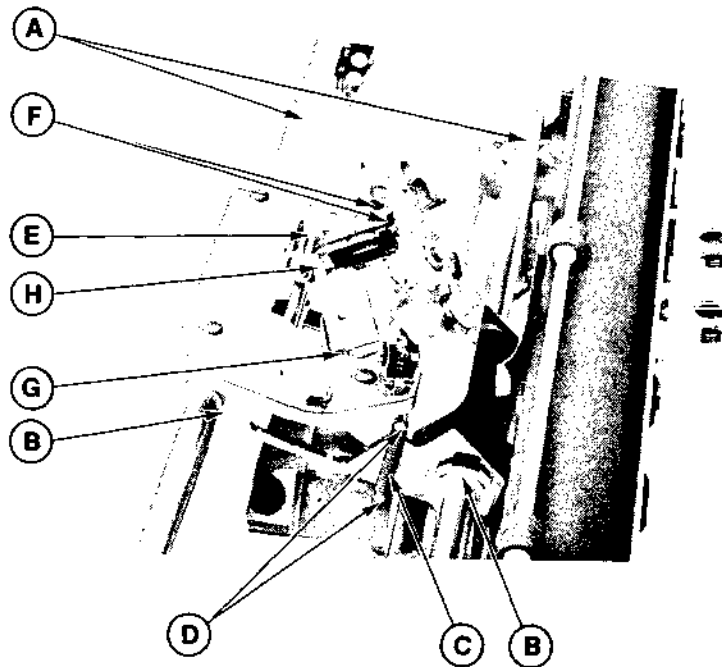

Figure 5-2 CARRIAGE SYSTEM LUBRICATION POINTS

3. Carriage Pivots (C) - Apply one drop of light oil to the pivot on each side of the carriage frame.
4. Carriage Pivot Spring Loops (D) - Lightly grease the end loops and posts of the pivot spring on each side of the carriage frame with multipurpose grease.
5. Ribbon Base Plate Pivots (E) - Saturate the felt washer on each end of the base plate pivot shaft with light oil.
6. Ribbon Drive System (F) - Apply one drop of light oil to the drive and idler gear shafts, and to the drive key slot.

7. Hammer Armature Pivots (G) - Remove the two rubber cups, and fill the grease chambers with Polyoil. Replace the rubber cups.
8. Print Hammer (H) - DO NOT lubricate this item. If a cloth ribbon is being used make sure the hammer is clean.

5.3.4.2 Carrier System

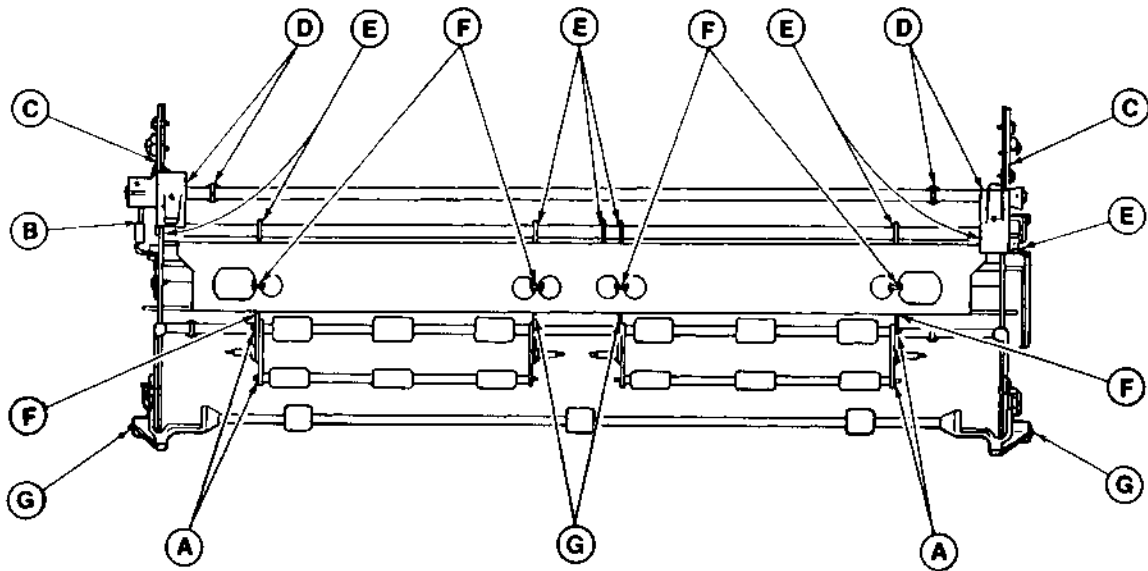

Figure 5-3 CARRIER SYSTEM LUBRICATION POINTS

Refer to Figure 5-3. Lightly grease or apply one drop of oil to the following points with either multipurpose grease or light oil as indicated.

1. Paper Feed Roller Shaft Pins (A) - grease 8 places.
2. Platen Position Lever Detent Plate (B) - grease.
3. Platen Position Slide Plates (Carrier Frame) (C), including exposed slide surfaces (lever moved limit to limit), and all points of contact with pivots, eccentrics, guides, etc. - grease.
4. Platen Position Torque Shaft Ends, Bearing Surfaces, and Spring Loops (D) - grease.
5. Paper Release Tab Ramp and Shaft Pivots (E) - grease.
6. Paper Release Arm Slots and Spring Ends (F) - grease.
7. Paper Bail Pivots (G) - grease.
8. Paper Carrier Pressure Lever Pivots (under) - oil.

5.3.4.3 Platen System

Refer to Figure 5-4.

1. Paper Feed Idler Gear (A) - Inspect the large felt washer behind this gear. If it is becoming white in color, saturate with Polyoil.

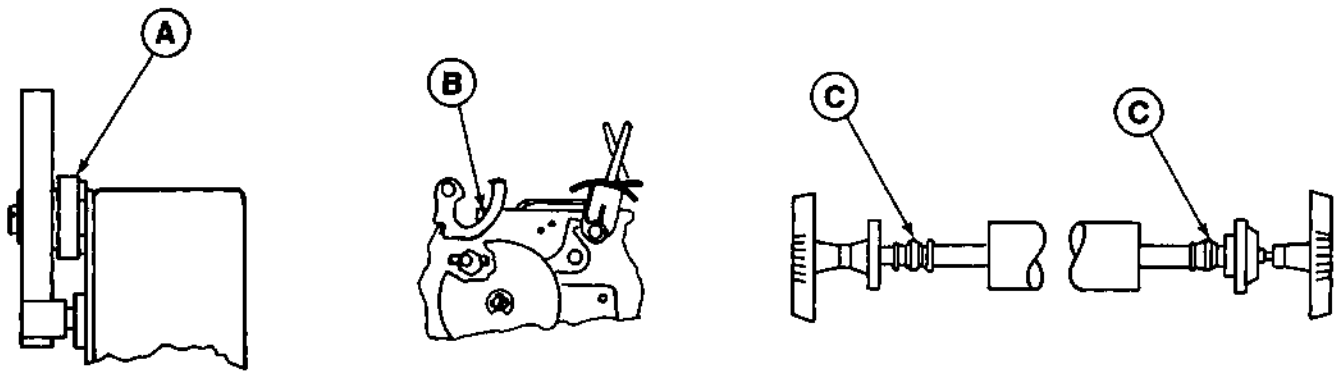

Figure 5-4 PLATEN SYSTEM LUBRICATION POINTS

2. Platen Release Tab Arms (B) - Lightly grease the contact area between these and the carrier frames with multipurpose grease
3. Platen Hubs (C) - Apply one drop of light oil to the bore of the hub at each end of the platen.

5.3.4.4 Lubrication of Optional Items

Optional platen styles require only the lubrication of their hubs as outlined above. The pin feed sections of the pin feed styles are internally self-lubricating and do not require user attention. The optional Diablo Forms Tractors likewise do not require lubrication. Lubrication of the optional Forms Handling units is covered in their individual maintenance publications.

5.4 CORRECTIVE MAINTENANCE - MAINTENANCE LEVEL 2

5.4.1 Corrective Maintenance Philosophy

Corrective Maintenance or repair may be divided into two periods - warranty and postwarranty. As long as the HyType II Printer's warranty remains in force, maintenance by the user should normally be limited to Level 1 Preventive Maintenance procedures. Diablo Customer Service should be contacted for assistance with more serious problems.

NOTE: The Diablo warranty is null and void when any Level 2 procedure has been unsuccessfully attempted. All time and material required to restore the printer to working order will be billed at prevailing rates. No adjustments should be attempted unless equipment malfunction indicates a specific need.

Beyond the warranty period, only the users capabilities and desires need govern the point at which Diablo technical assistance would be requested.

5.4.2 HyType II Service Tests

5.4.2.1 Trouble Shooting The HyType II Printer

The trouble shooting information included here is intended as an aid

TROUBLE SHOOTING FLOW CHART

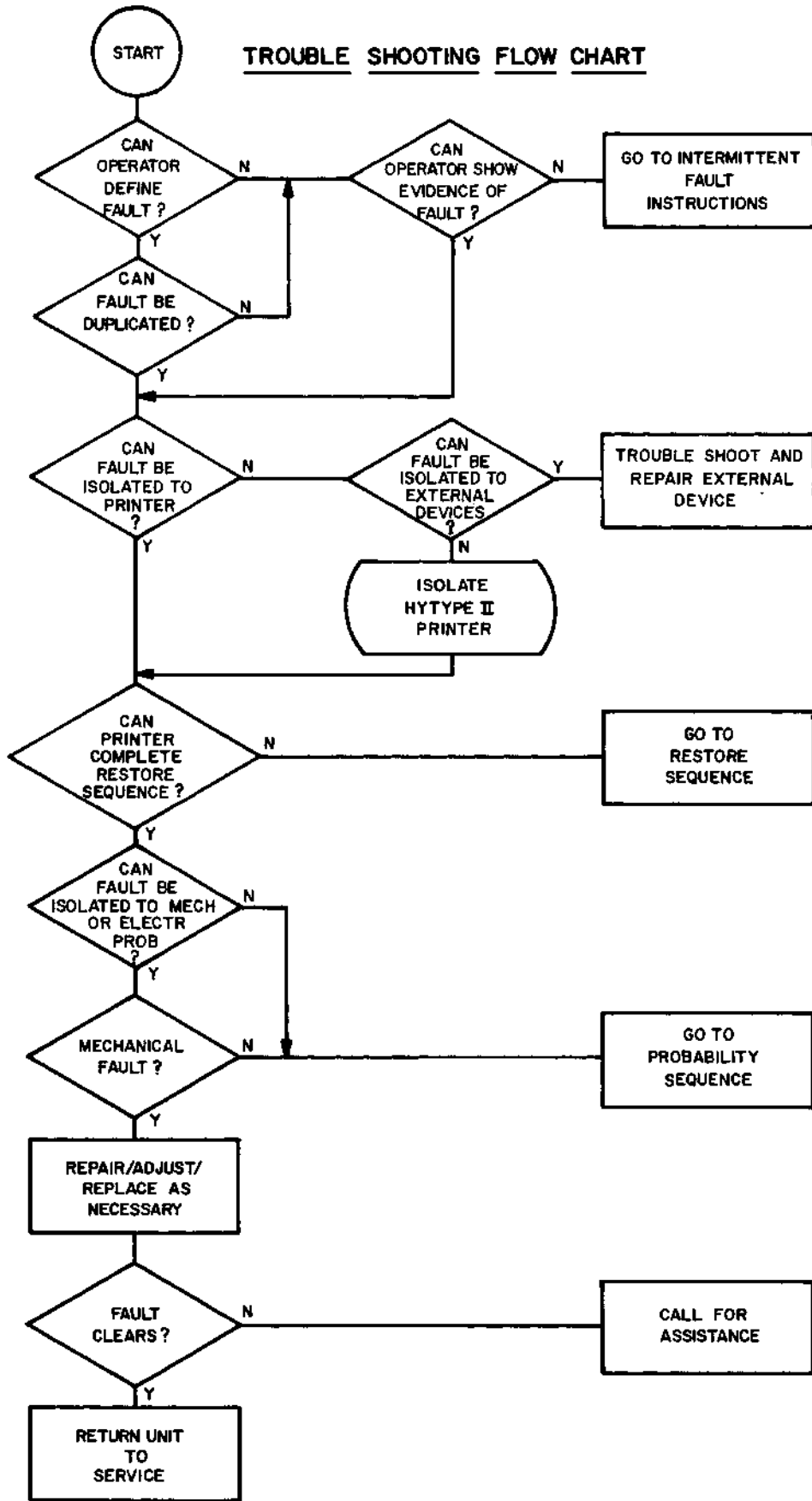

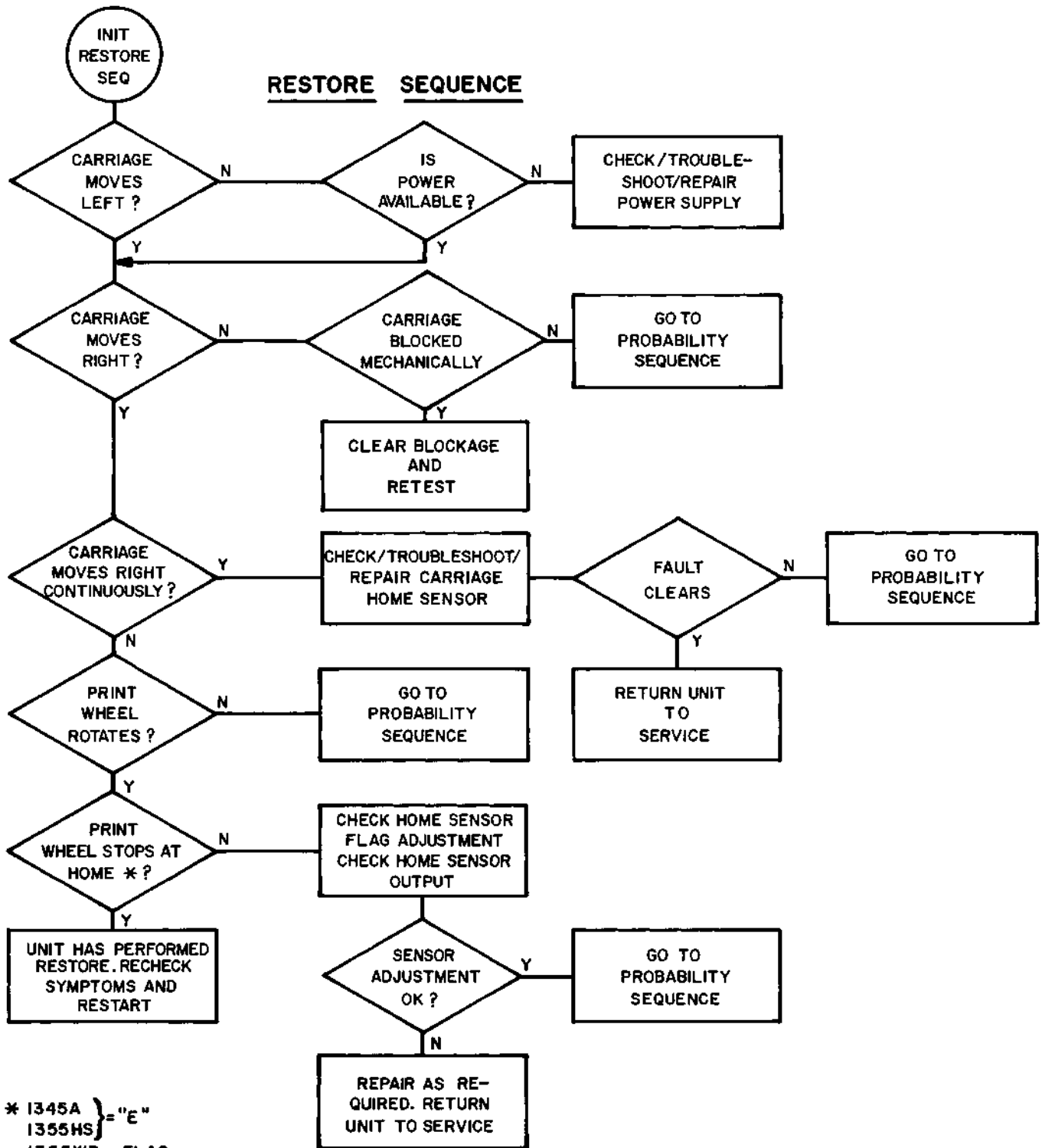

PROBABILITY SEQUENCE

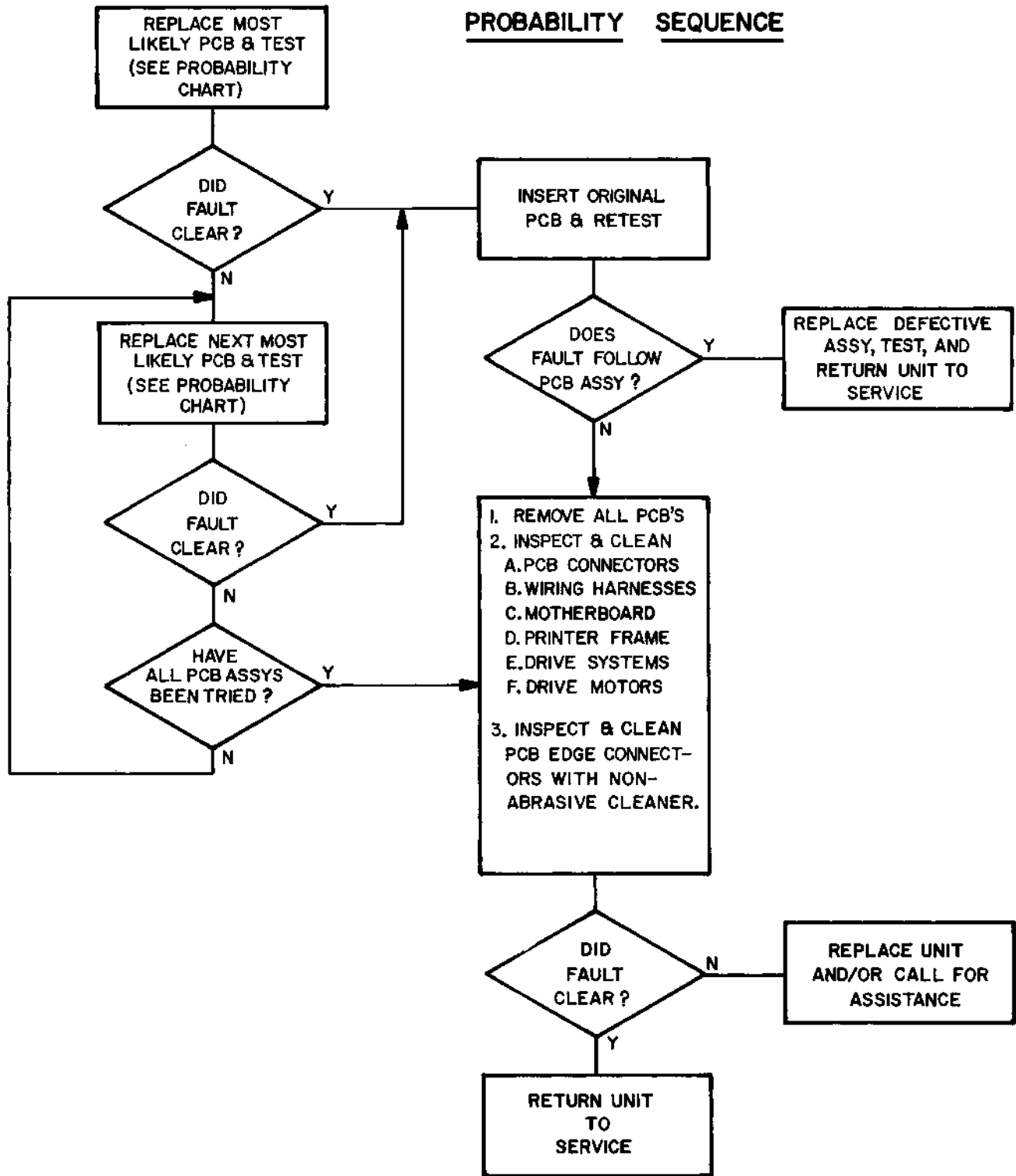

INTERMITTENT FAULT INSTRUCTIONS

NOTE: Some faults are by nature difficult to isolate and/or define.
The following steps may help in isolating intermittent faults.

1. Electrical Noise - Look for evidence of excessive static discharge, line voltage fluctuations, "brown out" conditions which exceed specified operating limits, poor/improper machine grounding, dirty/loose electrical connections, EMI/RFI conditions, eliminate or isolate the unit from such defects.
2. Debris/Contamination - Close physical examination of the unit may disclose shorts/opens/wire damage caused by debris (staples, paper clips, etc.) or contaminants (liquid spills, paper or environmental dust, etc.). Keep the unit clean.
3. Mechanical Interference - Look for binding or rubbing of moving parts. Listen for any unexpected noise which might help identify mechanical interference. Clean and lubricate the unit per specification.
4. As a general rule, remove all PCB's and clean their edge connectors with a non-abrasive cleaner. Disconnect, inspect, and reseal all electrical connectors. Clean the unit thoroughly and run any exercise routines which might help isolate the fault.
5. If all else fails, call for assistance. In some cases, replacement of major unit subassemblies, or the entire unit may prove to be more economical than attempting to isolate particularly difficult problems.

PROBABILITY CHART

NOTE: 1=Most likely, 2=Next most likely, etc.

A- Carriage Motion Problem

1. Logic #2 PCB
2. Logic #1 PCB
3. Carriage Power Amp PCB
4. Servo PCB
5. Transducer PCB
6. Connectors
7. Carriage Motor
8. Power Supply

B- Print Wheel Motion Problem

1. Logic #2 PCB
2. Logic #1 PCB
3. Print Wheel Power Amp PCB
4. Servo PCB
5. Transducer PCB
6. Carriage Assembly
7. Connectors
8. Power Supply

C- Ribbon Lift/Advance Problem

1. Print Wheel Power Amp PCB
2. Logic #2 PCB
3. Logic #1 PCB
4. Connectors
5. Carriage Assembly
6. Power Supply

D- Print Hammer Problem

1. Print Wheel Power Amp PCB
2. Carriage (hammer) Assy
3. Logic #2 PCB
4. Connectors
5. Servo PCB
6. Power Supply

E- Paper Feed Problem

1. Carriage Power Amp PCB
2. Logic #2 PCB
3. Logic #1 PCB
4. Connectors
5. Power Supply

to rapid isolation and correction of faults within the printer. This information is not intended as a substitute for qualified technical support.

The information on operational quality testing and service adjustments on the HyType II Printer which follows is included to assist a qualified technician in the rapid servicing and/or repair of the printer. The tests and adjustments given should be performed in the sequence outlined, even though only one or two of them may be used in any one service situation. This recommendation is made to reduce the time lost in rechecking adjustments made in previous steps. Note also that all checks, adjustments and/or alignments are to be made with the printer either in its operating position or on a work bench resting on its shock mounts. These procedures should not be attempted with the printer mounted on its shipping base.

5.4.2.2 Print Quality

Proper assessment of print quality requires that the print samples used for evaluation be obtained under standardized conditions. Therefore, tests should be made with a new print wheel and a multi-strike ribbon, on a good grade of standard bond paper, with the impression control switch set on medium (M) (see subsection 2.3.6).

1. Print a full line of "H's".

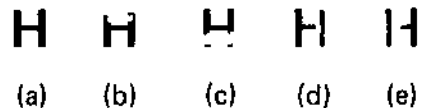

2. Compare the test results with the above illustration.
Item (a) -Impressions similar to this with uniform density and good edge definition indicate proper printer adjustment. A gradual change in density (lighter or darker) from one end to the other indicates a PLATEN TO PRINT WHEEL adjustment may be required.
Item (b) -Impressions similar to this indicate PLATEN HEIGHT adjustment for platen too low may be required.
Item (c) -Impressions similar to this indicate PLATEN HEIGHT adjustment for platen too high may be required.
Items (d)-Impressions similar to these indicate that a PRINT and (e) WHEEL TO HAMMER adjustment may be required.

5.4.2.3 Print Quality Adjustments

This subsection describes Adjustment Tools # 40795, 40795-02, 40796 and 301445-01, and describes their use in performing printer adjustments as follows:

- * Platen to Print Wheel
- * Print Wheel to Hammer
- * Card Guide Position
- * Ribbon Height
- * Carriage Home

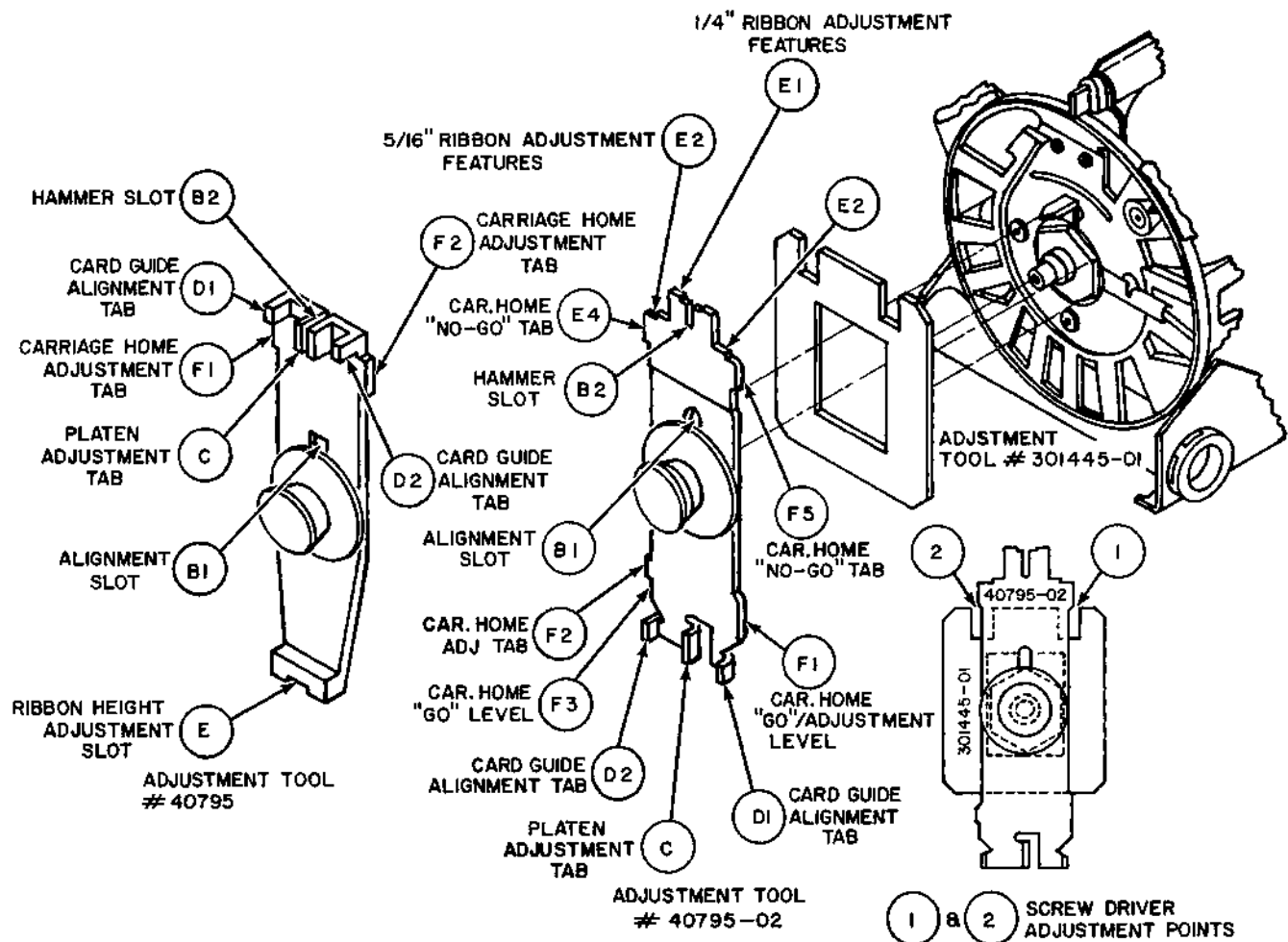

Figure 5-5 ADJUSTMENT TOOLS

Figure 5-5 identifies the several features of these tools by letter-number designators. In the procedures which call for the use of one of these tools, the features to be used are identified by these designators.

5.4.2.4 Conditions of Test and Alignment

1. Power - Power is to be applied to the Printer only when specified while making adjustments. It is used to electrically detent the print wheel and carriage servo motors, to hold the ribbon lift plate in operating position, and for cycling the Printer through a RESTORE sequence when required.
2. Platen - Platen-Carrier adjustments are to be made using a platen whose surface is in good condition and free from wear or defects.

3. Ribbon - Ribbon adjustments are to be made using a carbon ribbon cartridge.
4. Controls - The Platen Position Lever is to be brought fully forward for Platen-Carrier to Print Wheel adjustments.
5. Precautions - Always remove the Adjustment Tool(s) from the Print Wheel motor shaft before initiating a RESTORE sequence, to prevent damage to the printer. Also, always ensure that the tool is properly seated prior to making any measurements.

5.4.3 Paper Carrier System - Replacement and/or Adjustment Procedures

The following procedures detail the removal, replacement and adjustment of the paper carrier system subassemblies.

5.4.3.1 Paper Carrier Subassembly Removal

1. Remove the printer's covers, if any, and disconnect the printer completely (make sure power is off first). Remove the printer from its mounting, and place it on a sturdy work bench or table.
2. Remove and store the ribbon cartridge, print wheel, platen and paper cradle.

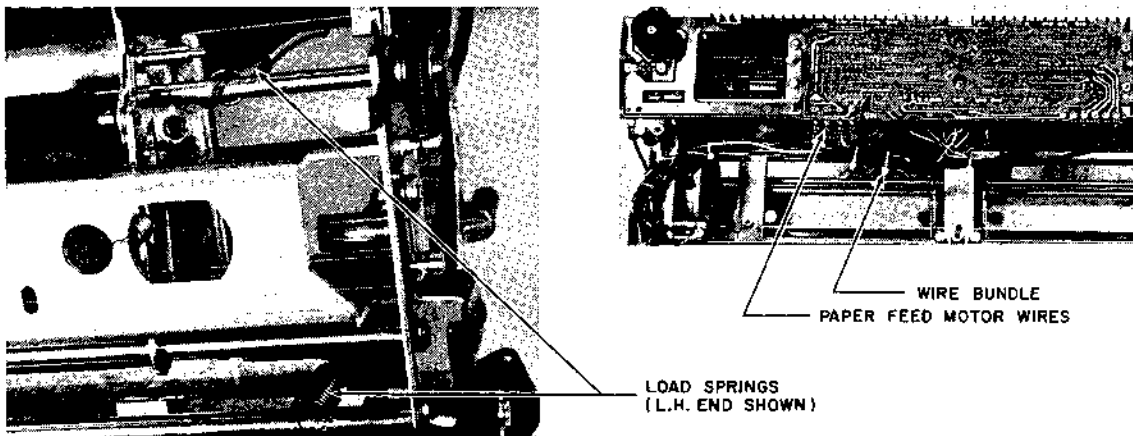

Figure 5-6 CARRIER SYSTEMS REMOVAL - A

3. Dismount the Cover Open switch and bracket, if installed. Stand the printer up on the front end of its main frame. Use the T-Handle Spring Hook #99009 to disengage the 4 Carrier System load springs from the printer's main frame (2 long springs in front and 2 shorter springs in the rear). Open the wire bundle and disconnect the 4 paper feed motor wires from the Motherboard PCB. Refer to Figure 5-6.
4. Return the printer to its upright position. Remove the E ring and the paper feed idler gear. Locate and remove the 2 carrier assembly load springs, one on each end of the assembly mounted between the inboard end of a stud on the rear of the carrier assembly (earlier models used the farthest rear platen position clamp screw) and the inboard end of a stud on the main frame (earlier

models used the end of the assembly support screw). Store the springs, gear and the E ring in a safe place. Refer to Figure 5-7.

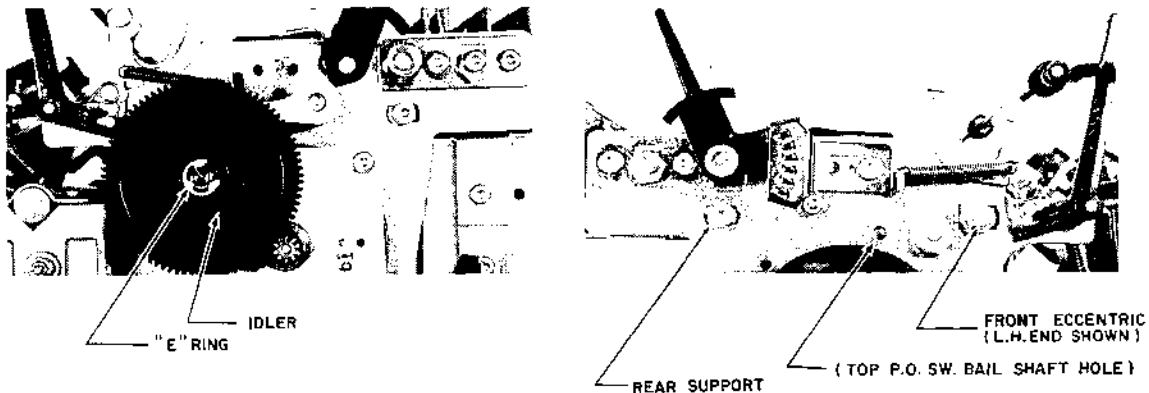

Figure 5-7 CARRIER SYSTEMS REMOVAL - B

5. Remove the left- and right-hand front Carrier Subassembly height adjustment eccentrics using a 1/4" wrench or nut driver. Remove the left- and right-hand Carrier Subassembly support screws and shoulder spacers (earlier models use a shoulder screw), using a TORX T15 screwdriver. Store these items in a safe place. Refer to Figure 5-7.

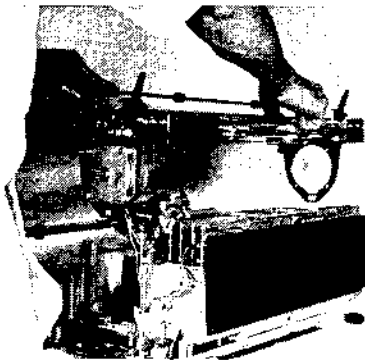

Figure 5-8 CARRIER SYSTEMS REMOVAL - C

6. Carefully lift the Carrier Subassembly, which includes the paper feed drive motor), free of the printer's main frame as shown in Figure 5-8. Be sure the motor's wires are free and not caught in the wire bundle.

5.4.3.2 Paper Feed Motor Removal and Replacement

NOTE: This part of the procedure can be used without removing the Carrier Subassembly.

1. If the Carrier Subassembly is not to be removed;
 - a) Remove the printer's covers, if any, and disconnect the printer completely (make sure power is off first). Move

the printer to a sturdy work bench or table.

b) Remove the platen and paper cradle, and dismount the Cover Open switch and bracket if installed.

c) Referring to Figure 5-7, remove the E ring and idler gear.

d) Stand the printer on the end of its main frame, open the wire bundle and disconnect the four paper feed motor wires from the Motherboard PCB. Return the printer to its upright position.

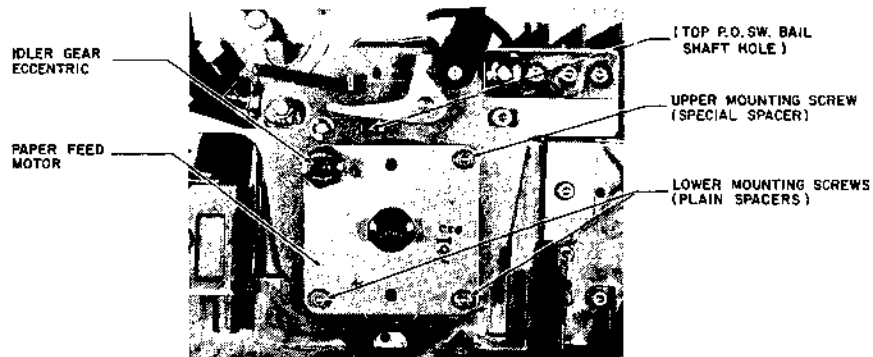

Figure 5-9 PAPER FEED MOTOR REMOVAL

2. Using a TORX T15 screwdriver, remove the three 8-32 x 3/4" screws holding the paper feed motor to the right-hand Carrier side frame as follows. Remove the two bottom screws first, and retrieve their spacers from between the motor flange and carrier frame. Remove the upper right-hand (as you view it) screw last, and retrieve its shoulder spacer from behind the motor flange. This shoulder spacer prevents motor side movement. Refer to Figure 5-9.
3. Tilt the motor down and out of the Carrier side frame, and gently pull its connecting wires free from the wire bundle inside the printer.
4. Using an 11/32" open end wrench and a blade screwdriver, remove the paper feed idler gear mounting stud eccentric, nut and two washers from the paper feed motor's upper left-hand flange hole. Refer to Figure 5-9.
5. Transfer the items removed in Step 4 above to the replacement motor exactly as they were arranged on the removed motor (upper left flange hole, nut and washers to the rear side). Thread the nut on finger tight only; it will be tightened down later in the adjustment procedure.
6. Carefully insert the replacement paper feed motor's connecting wires into the opening in the right-hand Carrier side frame, and tilt the motor into position in the frame opening.
7. Orient the paper feed motor with the idler gear eccentric stud upper left as shown in Figure 5-9. Insert the special shoulder spacer (removed last in Step 2) behind the motor's upper right flange, with its shoulder extending into the hole in the flange. Loosely thread one of the 8-32 x 3/4" screws into the Carrier side frame through the motor flange and spacer.

8. Place spacers behind and insert 8-32 x 3/4" screws (removed first in Step 2 above) through the two bottom motor mounting holes and finger tighten only. Now tighten the first screw (Step 7 above) until snug, but not so tight as to restrict lateral movement of the motor.

This completes the installation of the paper feed motor only on a Carrier Subassembly. If this was a motor replacement only (did not involve Paper Carrier removal) skip to subsection 5.4.3.3 - Step 6 below for the remaining steps to reconnect the motor electrically.

5.4.3.3 Paper Carrier Subassembly Installation Procedure

1. Clean all Carrier Subassembly bearing surfaces on the printer's main frame of old grease, etc. Reapply a light coating of multi-purpose grease to these points on both ends of the printer's main frame. Refer to Figure 5-10.

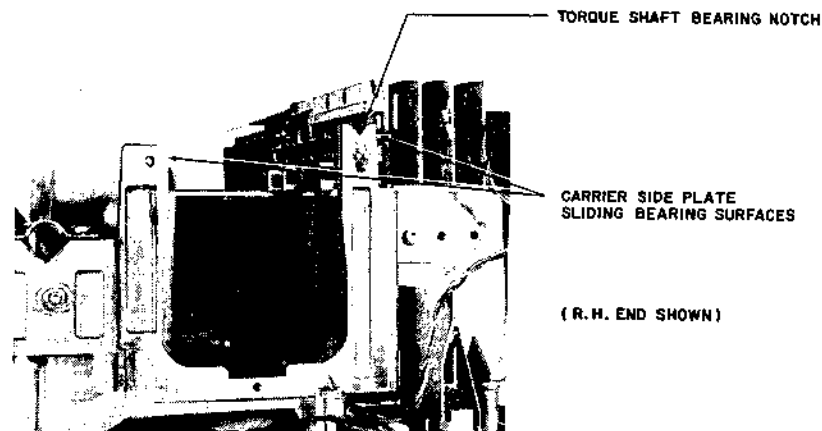

Figure 5-10 CARRIER SYSTEMS REPLACEMENT

2. Carefully lower the Carrier Subassembly into position on the printer's main frame. Refer to Figure 5-8.
3. Insert the left- and right-hand rear Carrier Subassembly shoulder spacers and support screws removed in subsection 5.4.3.1 - Step 5, using a TORX T15 screwdriver. Make sure the spacer shoulders pass into the slots in the Carrier side frame, and tighten the screws down firmly, but DO NOT overtighten and strip the threads from the holes in the printer's main frame casting.
4. Insert the left- and right-hand front Carrier Subassembly height adjustment eccentrics removed in subsection 5.4.3.1 - Step 5 using a 1/4" wrench or nutdriver. Make sure the shoulders of the eccentrics pass into the slots on the Carrier side frames, and thread the screws in enough to retain the eccentrics snugly in the slots, but do not tighten. The eccentrics should be positioned so their lobes point toward the rear of the machine.
5. Stand the printer on the front end of its main frame. Use the T-Handle Spring Hook #99009 to hookup the loose ends of the four Carrier Subassembly load springs to the main frame, making use of the holes provided. Subsection 5.4.3.1 - Step 3 detailed the unhooking of these springs.

6. Arrange the four wires from the paper feed motor into the wire bundle running along the edge of the Motherboard PCB, and connect them to the push-on terminals on the Motherboard PCB as follows: Gray wire to terminal T4; Black wire to terminal T5; Yellow wire to terminal T6; and the Red wire to terminal T7. Secure the wire bundle with plastic cable ties or equivalent. Return the printer to its normal position.

This completes the installation of the Carrier Subassembly and Paper Feed Motor. The following subsection 5.4.3.4 details the adjustment of the Paper Carrier System for proper operation, and includes the Paper Feed gear train.

5.4.3.4 Paper Carrier System Adjustments

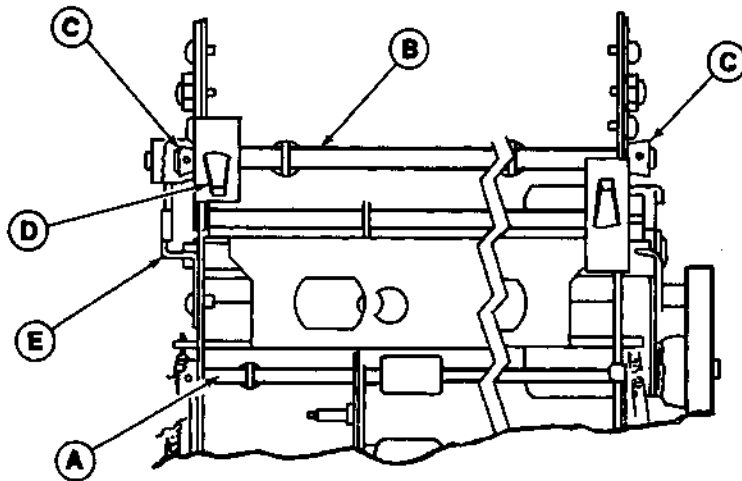

Figure 5-11 CARRIER ASSEMBLY ADJUSTMENTS

1. Carrier Assembly Adjustments. Refer to Figure 5-11.

Carrier Assembly Bias Shaft (A). Check for axial movement of .002", +.000" - .001". Adjust the collar at (A) as required to achieve this dimension.

Platen Position Torque Shaft (B). Check that the set screws in the eccentric collars (C) at each end of this shaft are aligned vertically with each other when the Platen Position Lever (D) is fully forward, and that the shaft end play is .002", +.000" - .001". Adjust the collars to achieve these end play dimensions. Failure of the collars to align vertically as described indicates a twisted Torque Shaft, which will affect platen alignment throughout the range of the Platen Position Lever.

Platen Position Lever (D). Move the lever back and forth. A positive detenting force must be felt for all positions. Adjust the detent plate (E) as necessary to achieve an even detenting action. The Carrier Subassembly must move equally at both ends within +/- .003" in increments of .005" +/- .002" between detent positions.

2. Paper Feed Adjustments

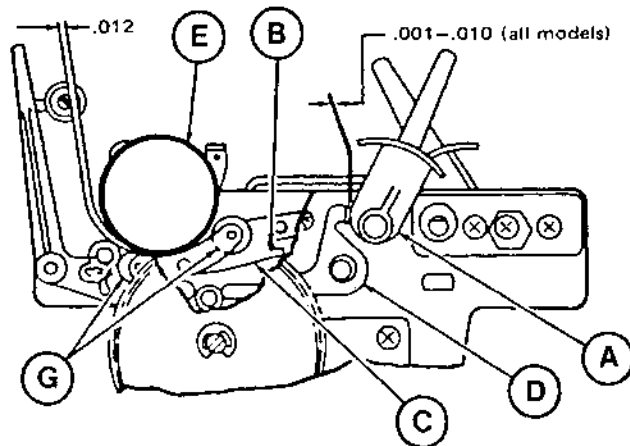

Figure 5-12 PAPER FEED ADJUSTMENTS

Refer to Figure 5-12.

With the Paper Release Lever (A) fully forward, the Paper Feed Rollers (G) must clear the Platen (E) by at least .08". The system is adjusted as follows to achieve this:

- * Insert 4 sheets of standard form paper (.012") and move the Paper Release Lever (A) fully rearward.
- * Ensure that the Torque Shaft Arm Tab (B) is touching the lower edge of the Feed Roller Support Arm slots (C).
- * Remove the 4 sheets of paper and reinsert 1 sheet. Ensure that the Paper Release Actuator (D) clears the ramp on the Paper Release Lever (A) by .001" to .010". Loosen the actuator's set screw and adjust the actuator to achieve this dimension. Retighten the set screw.
- * Remove the sheet of paper. Insert a 1" wide strip of paper, or a .004" shim, between the platen (E) and each of the front paper feed rollers (G), and check that both platen and rollers rotate when the strip (or shim) is pulled free. Repeat for all rear paper feed rollers (G). If rotation does not occur, the Torque Shaft Arm Tab (B) has been pushed down too low, and the Paper Release Actuator (D) should be readjusted.

3. Paper Feed Adjustment

Refer to Figure 5-13.

With paper feed motor drive gear (A) locked, the platen drive gear (B) must have .002" maximum play. Adjust the system as follows to achieve this, beginning with the platen removed:

- * Loosen the Paper Feed Motor mounting screws (D).
- * Rotate the Paper Feed Idler Gear Eccentric (E) COUNTER-CLOCKWISE only until a minimum backlash is obtained with no binding effect when the idler gear (C) is rotated a full 360° (clockwise rotation of the eccentric could prevent proper installation of the platen).

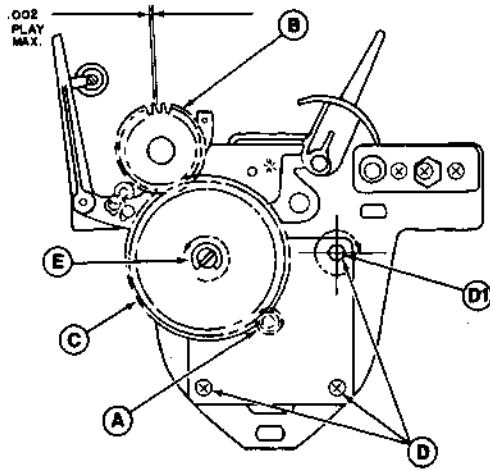
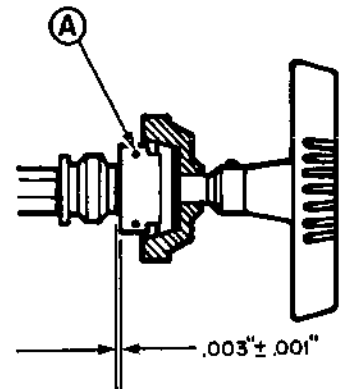

Figure 5-13 PAPER FEED DRIVE ADJUSTMENTS

* Install the platen. Rotate the Paper Feed Motor clockwise about mounting screw (D1) to remove backlash between the platen drive gear (B) and the idler gear (C). Tighten all screws.

4. Platen Knob Adjustment

Figure 5-14 PLATEN KNOB END PLAY ADJUSTMENT



Refer to Figure 5-14.

* Check for Platen Knob end play of .003", +/- .001", as shown. To adjust for this dimension, loosen the set screws in the platen gear hub and reposition the hub on its shaft. Retighten the set screws.

5.4.4 Carriage Systems - Replacement and/or Adjustment Procedures

The following procedures detail the removal and replacement, and/or adjustment of the Carriage Subassembly.

5.4.4.1 Carriage Subassembly Removal

1. Remove the printer's covers and accessories, if any, and disconnect the printer completely (make sure power is off). Remove the printer from its mounting, and place it on a sturdy work bench or table.

2. Remove and store the ribbon cartridge and print wheel.

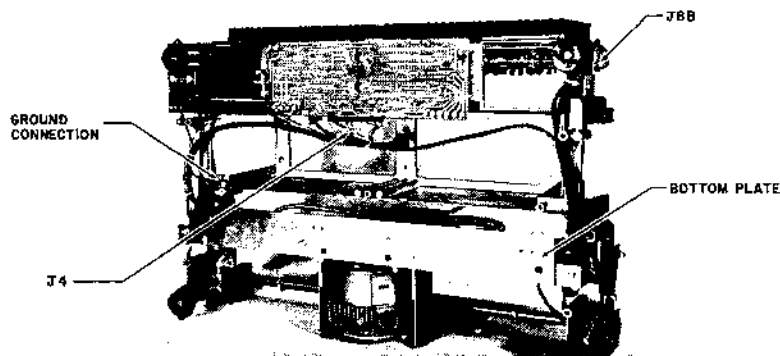

Figure 5-15 PREPARE CARRIAGE CABLES FOR REMOVAL

Refer to Figure 5-15.

3. Stand the printer up on the front end of its main frame. Open the left-hand (as you view it) wire bundle, and unplug the sheathed print wheel drive cable connector P4 at Mother-board PCB connector J4. Separate this cable from the wire bundle for later removal. Also disconnect the black ground wire, which is a part of this cable, where it is fastened to the main frame near the end of the cable's shield spring.
4. Open the right-hand (as you view it) wire bundle. Locate the sheathed cable extending from connector J8B on the Transducer PCB (Slot G) to the Carriage through the smaller cable shield spring. Unplug this cable at the PCB, and prepare it for later removal from the printer with the carriage.

NOTE: If the optional Bottom Feed Paper Chute is installed, skip to Step 6b.

5. Return the printer to its normal position near the front edge of the work surface.

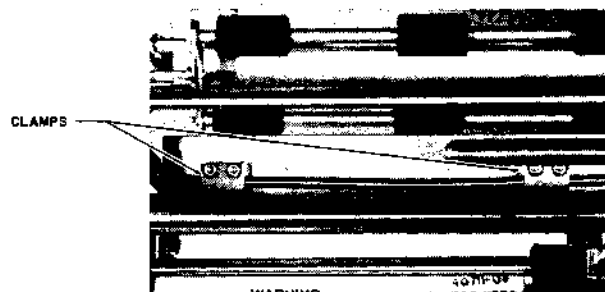
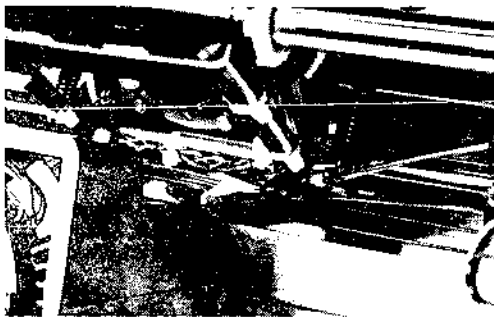

Figure 5-16 CABLE CLAMP REMOVAL

- 6a. Using the TORX T15 screwdriver, reach down behind the left end of the rear carriage rail and unscrew the four 6-32 x 1/2" screws holding the white plastic spring cable clamps to the bottom plate, as shown in Figure 5-16. Retrieve and store these screws. Reach down behind the right end of the rear rail and remove the large spring cable shield from the two spring clips holding it to the bottom plate.
- 6b. This step applies only to those printers with the optional bottom feed paper chute installed. Refer to Figure 5-15.
* Use the TORX T15 screwdriver to remove the four 8-32 x .625" screws which fasten the bottom plate to the printer's main frame.
Move this plate away from the frame far enough to release the large spring cable shield from the two spring clips, and to gain access to the four 6-32 x 1/2" screws used to clamp the small spring cable shield to the bottom plate. Remove these screws using the TORX T15 screwdriver.*
Return the printer to its normal position near the front edge of the work surface, and proceed to Step 7.

*Service Note: If the printer being worked on has other wire bundles fastened to the bottom plate with snap-in metal spring clips, remove these clips and replace them with cable ties.



A

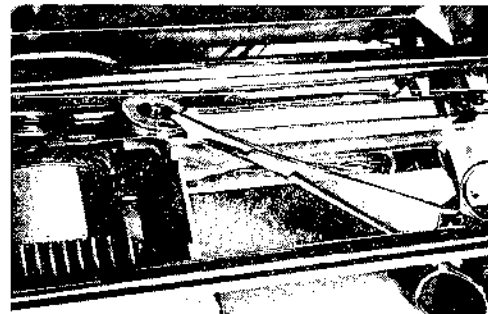

B

Figure 5-17 DISCONNECTING THE CARRIAGE DRIVE CABLE

Refer to Figure 5-17.

7. Position the carriage slightly to the right of center, to gain access along the right side of the carriage servo motor to the mounting screw for the carriage drive cable pulley. Install the hemostat clamp on the pulley as shown (use a piece of heavy paper between pulley and clamp jaws to protect the pulley flanges). This prevents the pulley from moving or flipping over and releasing the drive cables. Refer especially to Figure 5-17(B). Note that the clamp is installed to trap the upper forward right-hand cable segment between its jaws as it is clamped to the pulley. Make sure this has been done, and that the clamp is secure before proceeding.

Use the TORX T15 screwdriver to reach up beside the carriage motor and remove the pulley mounting screw. Make sure the pulley is free from the carriage frame, and gently move the carriage to the left to clear the pulley. Retrieve the spacer from the top of the pulley, and note that the spacer has a shoulder which extends down into the center of the pulley when properly assembled. Store the spacer and pulley mounting screw. **DO NOT** remove the hemostat clamp from the pulley!

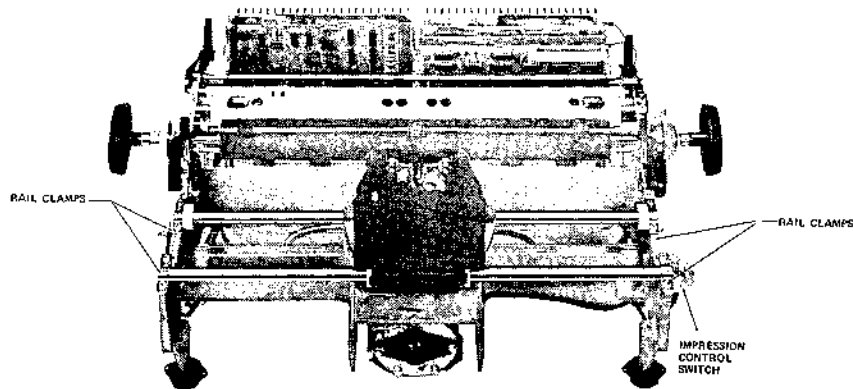

Figure 5-18 CARRIAGE RAIL CLAMPS

Refer to Figure 5-18.

8. Using the TORX T15 screwdriver, remove the eight 8-32 x .625" carriage rail clamp screws and clamps, and dismount the impression control switch if present. Store the loose items. Grasp the carriage and rails in one hand and carefully lift the assembly up and out of the printer's main frame while guiding the two spring shielded cables and their connectors clear of the printer structure.
9. Lay the carriage and rail assembly on a clean flat surface. Slide the front rail sideways out of the front carriage bearing sleeve and put it aside in a safe place. Slide the heavy rubber bumper washers off the ends of the rear rail. Note that there are two (2) heavy rubber washers on the left end, and only one (1) on the right end of the rear rail. Remove and store these washers. Finally, carefully slide the rear rail sideways out of the rear carriage bearing sleeve, and place with the front rail.

This completes the removal of the Carriage Subassembly.

5.4.4.2 Carriage Subassembly Replacement

Replacement Carriage Subassemblies are complete, aligned and functionally tested at the factory. They are ready for installation and operation as received, and usually require only a minor readjustment or two for print quality after installation.

1. Carefully remove the white felt washers from their plastic bag (shipped with each carriage subassembly), and saturate 4 of them (there are usually 1 or 2 extra) with light oil.

2. Unless replacement of the carriage drive cable is to be included at this time, remove the drive pulley and spacer from the underside of the replacement carriage.
3. Retrieve the carriage rails from their storage place, and thoroughly clean them with alcohol. After cleaning, check both rails for straightness and surface defects. Replace any rail which is bent or defaced.

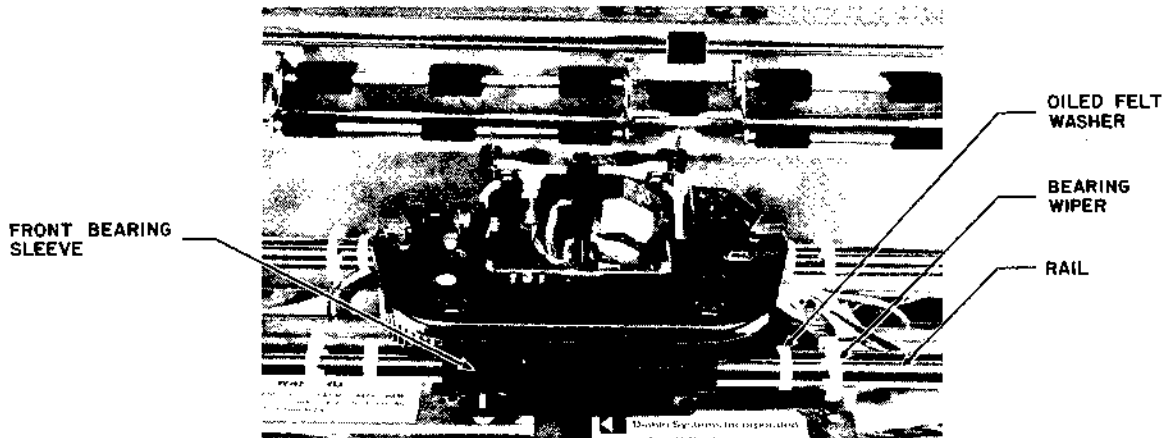

Figure 5-19 CARRIAGE AND RAIL REASSEMBLY

Refer to Figure 5-19.

4. Slide the cleaned and inspected carriage rails through the front and rear carriage bearing sleeves.
5. Gently slide an oil saturated felt washer over each end of both rails (CAREFUL! These washers are easily damaged), followed by a white plastic bearing wiper. Push the washers into their bearing sleeves with the bearing wipers, and snap the wipers into position on the ends of the bearing sleeves.
6. Install the heavy rubber bumper washers on the rear carriage rail, two on the left end, and one on the right end.
7. Gently lower the carriage subassembly and rails down onto the printer's main frame with the rail ends nested in the frame notches. Move the rails until even on each end, and reinstall the rail clamps, and the impression control switch (if present).
8. Hold the two spring shielded cables up out of the way, and gently slide the carriage back and forth as far as it will go. Carriage movement must be smooth and even, with no evidence of binding or roughness.

CAUTION: DO NOT slide the carriage hard to the left as this may damage the carriage home sensor (mounted on the main frame) with the sensor flag (mounted on the underside of the carriage).

9. Place the spacer on top of the carriage drive pulley, shoulder extending down into the center of the pulley. Position the carriage over the clamped pulley, and insert the mounting

screw. The spacer and screw were removed in subsection 5.4.4.1 Step 7. Tighten the screw down firmly with the TORX T15 screwdriver, and carefully remove the Hemostat Clamp.

NOTE: If the optional bottom feed paper chute is installed skip to Step 11b below.

10. Arrange the small (transducer) spring shielded cable from the right side of the carriage down inside the printer's main frame behind the carriage drive cable, and back to the left along the center of the bottom plate. Extend its free end out of the bottom of the printer to the left. Position the first plastic clamp over the threaded screw hole farthest left in the bottom plate, with its holes to the rear. Thread in two 6-32 x 1/2" screws, place the spring shield in the clamp with about 1/8" of the spring extending to the left beyond the clamp, and with the loop of the spring as straight as possible vertically. Tighten down the two clamp screws using a TORX T15 screwdriver. Move the second plastic clamp into position, holes to the rear, just left of center on the bottom plate over the two threaded holes provided; insert two more 6-32 x 1/2" screws and tighten them down.
- 11a. Arrange the large (print wheel) spring shielded cable from the left side of the carriage down inside the printer's main frame behind the smaller spring shielded cable just installed and along the rear edge of the bottom plate. Extend its free end out the bottom of the printer to the right. Position the spring as straight as possible vertically, with the end of the shield spring about 1/8" beyond the spring clip mounted farthest right on the bottom plate, and push the spring back under the clip. Push the body of the spring shield under the second spring clip located just to the right of center on the bottom plate.
- 11b. This step applies only to those printers with the optional bottom feed paper chute installed.
- # Position the bottom plate behind the carriage, in the area of the platen, with its spring clips (for the large cable) to the right on top.
 - # Loop the small (transducer) spring shielded cable from the right side of the carriage back around to the left, and position its plastic clamps over the screw holes left of center and near the left end of the bottom plate. Thread in the 6-32 x 1/2" screws to hold the clamps in place, but do not tighten them.
 - # Loop the large (print wheel driver) spring shielded cable from the left side of the carriage back around to the right over the smaller spring shielded cable, and snap it into the two spring clips right of center and near the right end of the bottom plate.
 - # Stand the printer up on the front edge of its main frame. Work the bottom plate, with cables attached, back through the main frame. Move the plate into position and fasten it down with the four 8-32 x .625" screws removed in Step 6b of subsection 5.4.4.1, using the TORX T15 screwdriver. Secure the carriage drive motor wire bundles to the plate with cable ties.

12. Stand the printer up on the front end of its main frame. Arrange the two sheathed cables into the wire bundles from which their counterparts were removed in Steps 3 and 4, subsection 5.4.4.1, and plug them in; Transducer Cable (smaller) to connector J8B on the Transducer PCB (Slot G); and the Print Wheel Drive Cable (larger) to connector J4 on the Motherboard PCB. Secure the two wire bundles with cable ties. Return the printer to its normal position.

This completes the removal and replacement of the Carriage Subassembly

5.4.4.3 Paper Carrier System To Carriage System Adjustments

The following procedures detail the adjustment of the movable Paper Carrier Subassembly (platen) to the essentially fixed Carriage Subassembly (print wheel). The adjustments included are platen horizontal movement (platen to print wheel), and platen vertical movement (platen height). The objective of these adjustments is to align the platen with the carriage and its print wheel everywhere on its path of movement along fixed rails, to achieve print quality. Note that adjustment of either of the platen movements affects the other. When adjustment is made to one, the other should be checked to ensure a quality of printout within the limits specified.

The checks and adjustments are to be performed with the printer connected to an exerciser or tester, and a power supply.

1. Platen To Print Wheel Adjustment

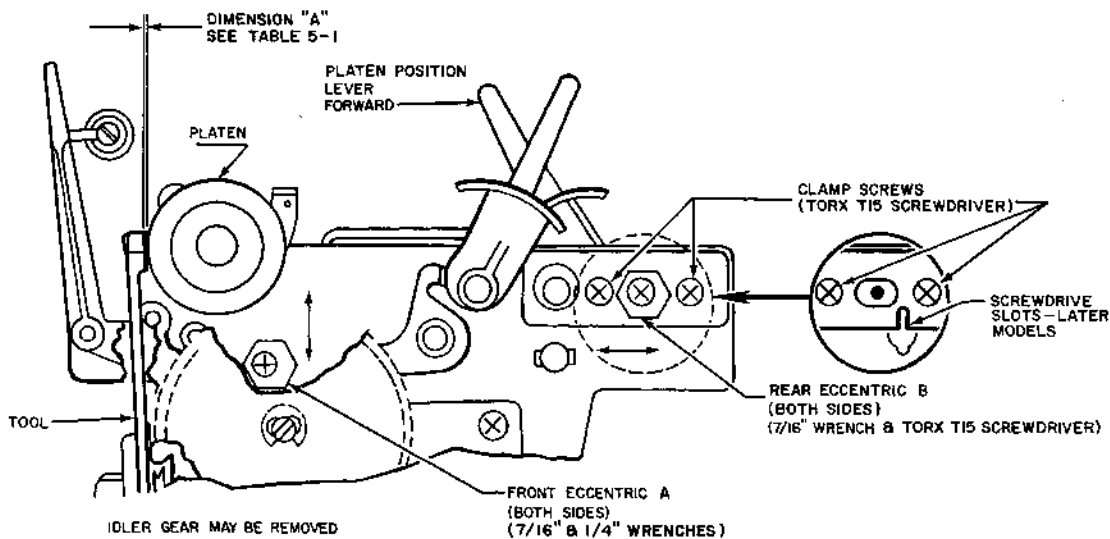

Figure 5-20 PLATEN TO PRINT WHEEL ADJUSTMENT POINTS

Refer to Figures 5-5 and 5-20, and to subsections 5.4.2.2 and 5.4.2.3.

Make sure power is OFF to the printer. Remove the ribbon cartridge and print wheel.

- # Loosen the two 3/16" hex head (or slotted pan head) card guide mounting screws on the carriage, and lower the card guide as far as it will go. Tilt the print wheel motor forward.
- # Install Adjustment Tool #40795, or #40795-02 (and #301445-01 as required), on the print wheel motor hub. Make sure the alignment slot (B1) in the tool properly engages the alignment tab on the print wheel motor hub, and that the tool is fully seated on the hub.
- # Tilt the print wheel motor and tool back into operating position and verify that the card guide alignment tabs (D1 and D2) on the adjustment tool clear the top edge of the card guide.
- # Use 1/4" and 7/16" wrenches to adjust the front (platen height) eccentrics (A) on each side of the printer so that the eccentric lobes are aligned toward the rear of the printer and are centered in their slots in the carrier side frames. Retighten the 1/4" hex head eccentric clamp screws.
- # Loosen the two rear eccentric clamp screws on each side of the printer, using a TORX T15 screwdriver. Use the T15 screwdriver and a 7/16" wrench to adjust the rear (platen position) eccentric (B) on each side of the printer so that the eccentric lobes are aligned upward, and are centered in their slots in the carrier horizontal adjust plate. Note that on later assemblies the eccentric (B) has been eliminated and replaced with a screwdriver slot - use a blade screwdriver to align the two halves of the slot on these units.
- # Make sure the Platen Position Torque Shaft eccentrics are adjusted per subsection 5.4.3.4, and move the Platen Position Lever fully forward.

TABLE 5-1
PLATEN TO PRINT WHEEL CLEARANCES

Model	1345A	1355WP*	1355HS
Dimension "A"	.001"-.009"	.005"-.010"	.004"-.011"

*NOTE: Early Model 1355WP with early sand cast main frames may not be adjustable to the .005"-.010" specification. Adjust these for a maximum clearance of 0.13", or adjust the platen to the card guide as indicated below.

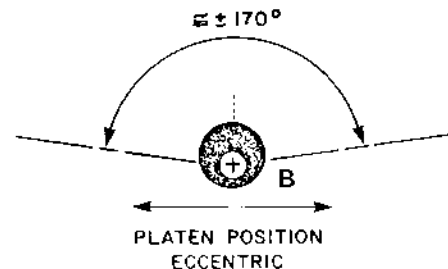

Figure 5-21
PLATEN POSITION ECCENTRICS
ADJUSTMENT LIMITS

- # Refer to Table 5-1. Move the carriage from one end of its travel to the other end. Stop the carriage at each end and, using flexible (plastic) thickness gauges, check the clearance between the platen surface and the tool's platen adjustment tab(s) (C) per the dimensions listed in Table 5-1 for the model printer being serviced.
- # Adjust the rear (platen position) eccentric (B), or slot on each side as necessary to achieve a platen horizontal position adjustment within the tolerances specified in Table 5-1. Figure 5-21 depicts the approximate limits of adjustment for these eccentrics.

NOTE: The platen height adjustment must be checked following platen position adjustment, and vice versa.

2. Card Guide Height and Position Adjustment

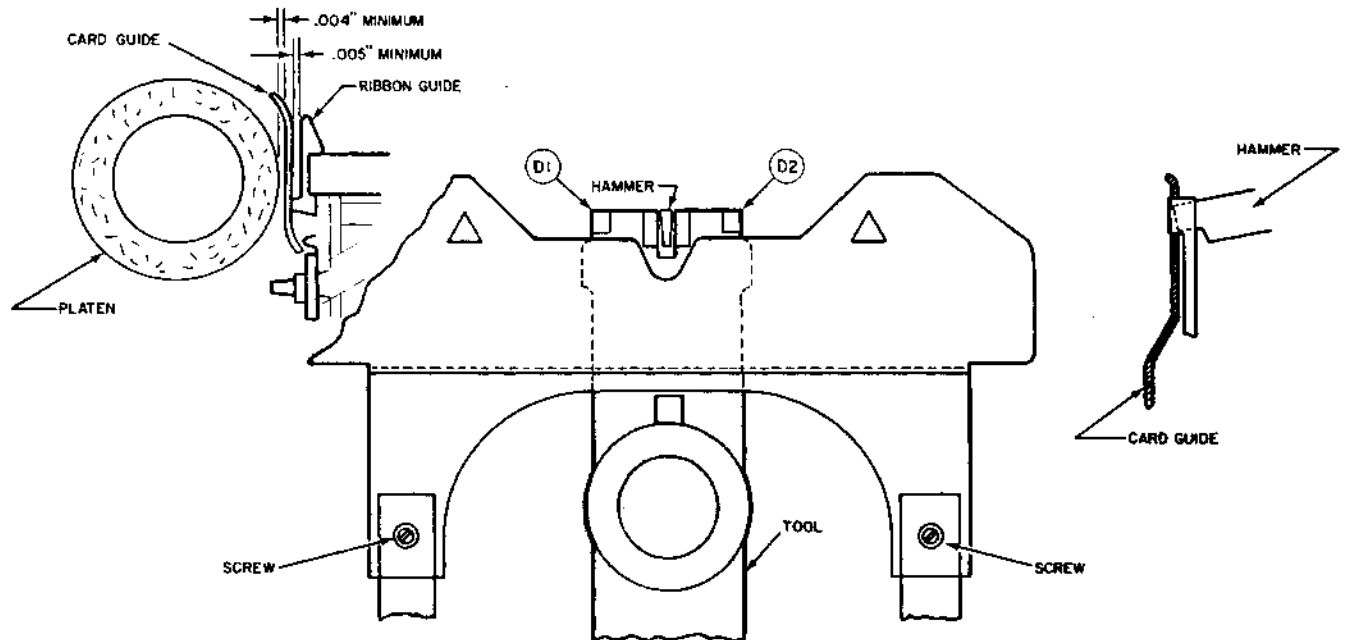

Figure 5-22 CARD GUIDE ADJUSTMENTS

- # If not done in the previous procedure, loosen the two 3/16" hex head card guide mounting screws (slotted screws in older models), and move the card guide down.
- # Make sure the Adjustment Tool is firmly seated on the print wheel motor shaft hub. Rotate the tool until features D1/D2 are at the top.

Tool #40795 - Push the Print Hammer into the tool's hammer slot B2 and hold it there. Raise the card guide gently, until its top edge contacts the undersides of tool tabs D1 and D2 with EQUAL pressure. Release the hammer and while holding the card guide in contact with the tool tabs tighten the two card guide mounting screws.

Tool #40795-02 - Raise the card guide until its top edge contacts the undersides of tool tabs D1 and D2. Gently move the tool slightly from side to side until the guide rests against the tabs with EQUAL pressure. Hold the card guide firmly in this position and tighten the two card guide mounting screws.

- # Using a .005" plastic shim, check for no-drag shim clearance between the card guide and the ribbon guide posts on both sides of the carriage. Normally this dimension is set by the

depth of the ribbon guide post tabs. Shim drag indicates the card guide has become tilted, in which case its support arms should be gently reformed to achieve proper ribbon post clearance.

Using the .005" plastic shim, check for no-drag clearance between the card guide and the platen along the full length of the platen.

NOTE: If the printing task involves bidirectional feeding of perforated multipart forms where the perforations must cross the writing line in reverse, an optional card guide #40550-02 must be used. In this event the following adjustment tolerances apply.

Print Line Base to Card Guide Cutout Base = .000" to .010"
 Card Guide to Platen = .004"
 Card Guide to Ribbon Post remains = .005"

3. Ribbon Height Adjustment

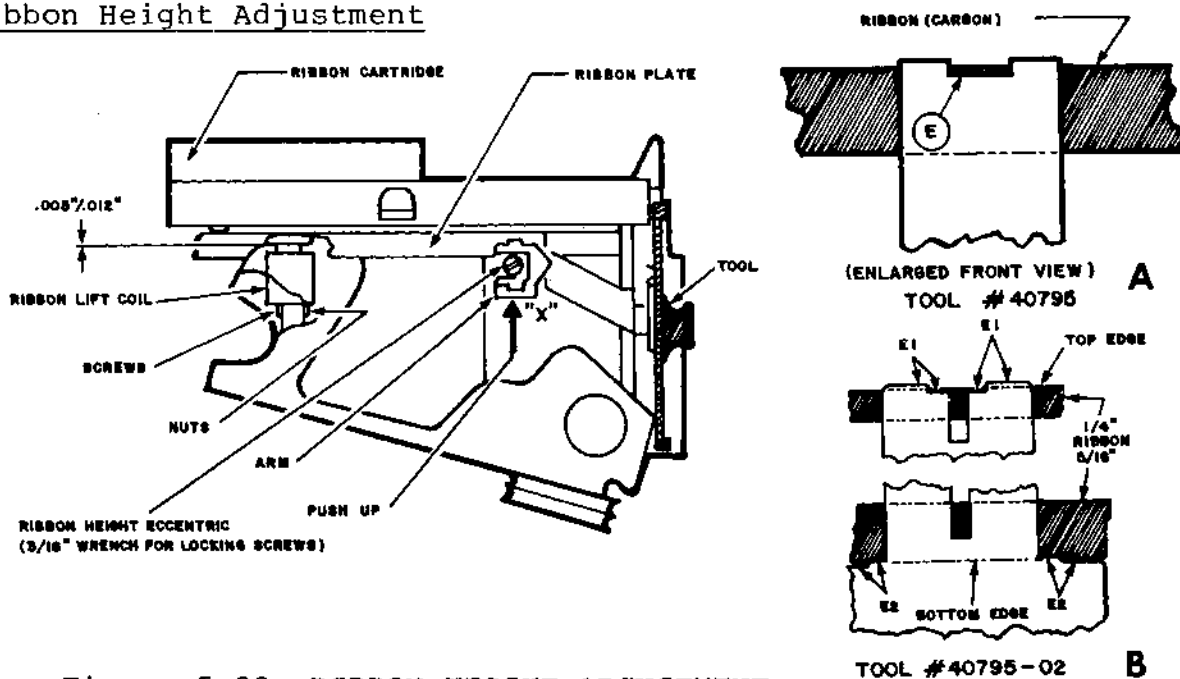

Figure 5-23 RIBBON HEIGHT ADJUSTMENT

Adjustment Tool #40795 - 1/4" Ribbons ONLY. Refer to Figure 5-23 (A).

- # Remove the ribbon cartridge and print wheel (if installed). Install the #40795 Adjustment Tool on the print wheel motor shaft hub, and rotate the tool to bring the ribbon height adjustment feature (E) to the top.
- # Tilt the print wheel motor into operating position, and install a multistrike carbon film ribbon cartridge.
- # Push up on the carriage ribbon base plate tab "X" so the TOP EDGE of the exposed ribbon is brought near the top of the tool. The top edge of the ribbon should be visible within the slot, as shown in Figure 5-23(A). Adjust the ribbon height eccentric as required to achieve this objective.
- # Remove the cartridge and tool. Replace the print wheel and the operating ribbon cartridge removed in the first step above.

Adjustment Tool #40795-02 - 1/4" OR 5/16" Ribbons. Refer to Figure 5-23(B).

- # Remove the ribbon cartridge and print wheel (if installed). Install the #40795-02 Adjustment Tool on the print wheel motor shaft hub, and rotate the tool to bring its hammer adjustment slot feature (B2) to the top.
- # Tilt the print wheel motor into operating position, and install a multistrike carbon film ribbon cartridge.
- # Push up on the carriage ribbon base plate tab "X" so that the tab (or grommet) is held against the carriage ribbon height eccentric.
- # Check the position of the exposed portion of the ribbon for proper height adjustment as follows:
 - 1/4" Ribbons -The TOP edge of the ribbon must appear between the high and low planes of tool features (E1).
 - 5/16" Ribbons -The BOTTOM edge of the ribbon must appear between the high and low planes of tool features (E2).
- # Adjust the ribbon height eccentric as required to achieve proper ribbon height.

The adjustment procedure for ribbon lift is as follows:

- # Remove the ribbon cartridge. Place a .005" plastic shim between the ribbon lift coil laminations and the ribbon base plate pole piece. Push up on the ribbon base plate tab (X) so that the ribbon height tab (or grommet) is firmly against the eccentric. Energize the ribbon lift coils with 12-15V dc and insure that the laminations are firmly and equally seated against the pole piece. Loosen the 3/16" coil mounting screws and adjust the position of the coils with respect to the pole piece as required to achieve these goals. Retighten the mounting screws and remove the shim.
- # Recheck the ribbon height adjustment as outlined above. Re-adjust as required, then recheck the coil adjustment.

4. Platen To Print Wheel Adjustment - Platen Height

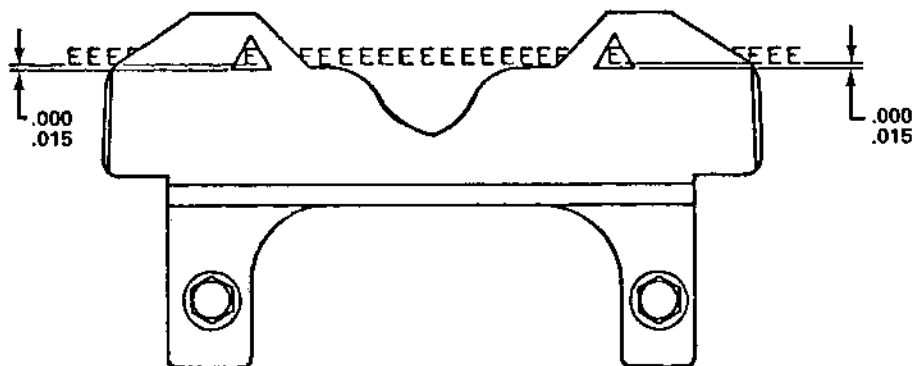

Figure 5-24 CARD GUIDE ALIGNMENT

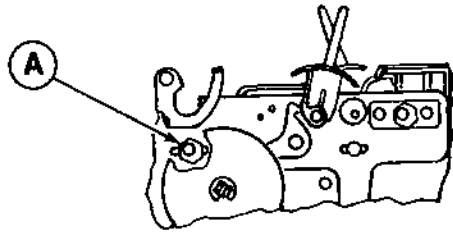

Figure 5-25 PLATEN HEIGHT ECCENTRICS

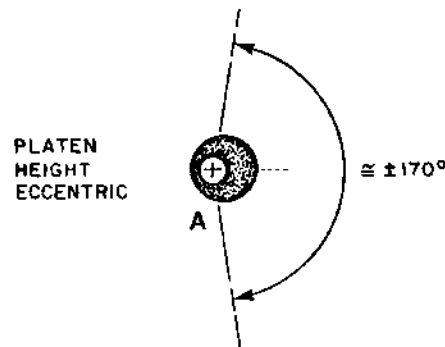

Figure 5-26
PLATEN HEIGHT ECCENTRICS
ADJUSTMENT LIMITS

Refer to Figures 5-20 and 5-24, and to subsection 5.4.2.2.

- # Connect the printer to a tester and apply power. Allow the printer to complete its RESTORE sequence.
- # Insert a sheet of wide (14-3/8") paper, and command the print-out of a full line of A's.

Refer to Figure 5-24. Check the alignment of the card guide. As shown, the bottom lines of the printed A's must be even with the bottom edges of the triangular openings (A1) in the card guide (A) within .000" to .010" as shown. Make minor adjustments to the card guide height as required to achieve proper card guide positioning. See NOTE in subsection 5.4.4.3 step 2.

Refer to Figures 5-25 and 5-26, and to subsection 5.4.2.2.

- # Command the printout of a full line of H's. Inspect the printout against the examples in subsection 5.4.2.2. Use 1/4" and 7/16" wrenches to adjust the platen height eccentrics (A), one end at a time, to achieve an even printout top to bottom on each character. Print a full line of H's after each adjustment to check results.

NOTE: The platen position adjustment must be checked following a platen height adjustment and vice versa.

5.4.4.4 Carriage Home Adjustment

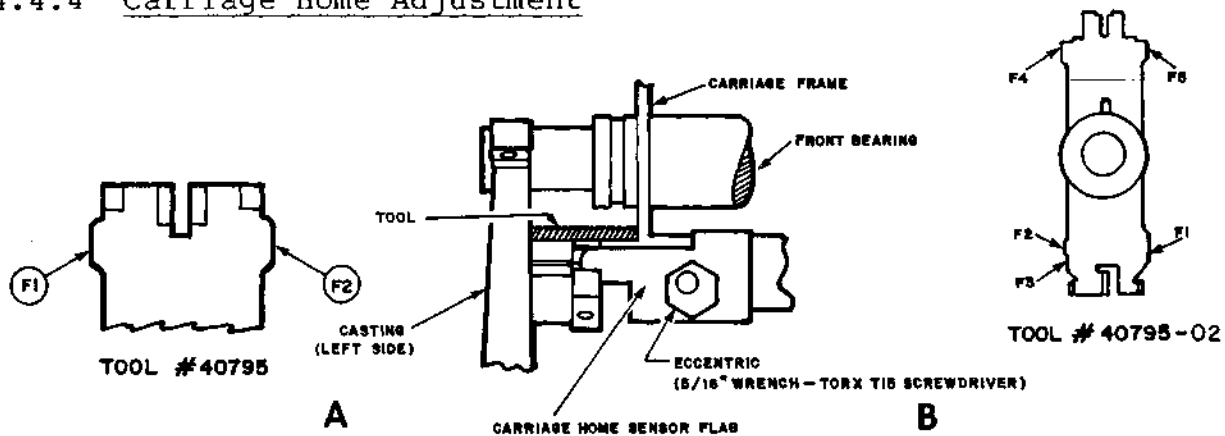

Figure 5-27 CARRIAGE HOME ADJUSTMENT

Refer to Figure 5-27, and to subsection 5.4.2.3.

Adjustment Tool #40795

- # Apply power to the printer and allow the printer to complete its RESTORE sequence. Verify that the carriage has been left in its home position.
- # Insert the Adjustment Tool between the left side of the printer's main frame casting and the carriage frame just above the carriage home sensor, as shown in Figure 5-27(A). Check for a cumulative clearance of no more than .017" between the tool's carriage home alignment tab features F1/F2 and the printer assemblies.
- # If the carriage home position is not within allowable limits following RESTORE, adjust the carriage home sensor flag eccentric, located on the bottom left front of the carriage frame, using a 5/16" wrench and a TORX T15 screwdriver. The eccentric is adjusted to move the sensor flag LEFT for not enough clearance, and RIGHT for too much clearance.
- # Move the carriage right manually and recycle the printer through the RESTORE sequence after each small movement of the eccentric to check results. Tighten the eccentric clamp screw securely when the adjustment has been completed.

Adjustment Tool #40795-02.

- # Apply power to the printer and allow the printer to complete its RESTORE sequence. Verify that the carriage has been left in its home position.
- # Insert the Adjustment Tool between the left side of the printer main frame casting and the carriage frame, just above the carriage home sensor, as shown in Figure 5-27(B). Using tool features F1 through F5, check for proper passage of the tool as follows:
 - Features F4/F5 SHOULD NOT pass (no-go)
 - Features F1/F3 SHOULD pass (go)
- # If carriage home position following RESTORE is not within these limits (i.e. F4/F5 passes, or F1/F3 will not pass), adjust the carriage home sensor flag eccentric, located on the bottom left front of the carriage frame, as follows. Use tool features F1/F2 as a gauge between carriage and main frame as

before, and a 5/16" wrench and a TORX T15 screwdriver to move the eccentric. Adjust the eccentric to move the sensor flag LEFT for not enough clearance, or RIGHT for too much clearance.

- # Remove the tool, move the carriage to the right manually, recycle the printer through a RESTORE sequence, and recheck tool clearance after each small movement of the eccentric. Tighten the eccentric clamp screw securely when the adjustment has been completed.

5.4.4.5 Print Wheel To Hammer Alignment

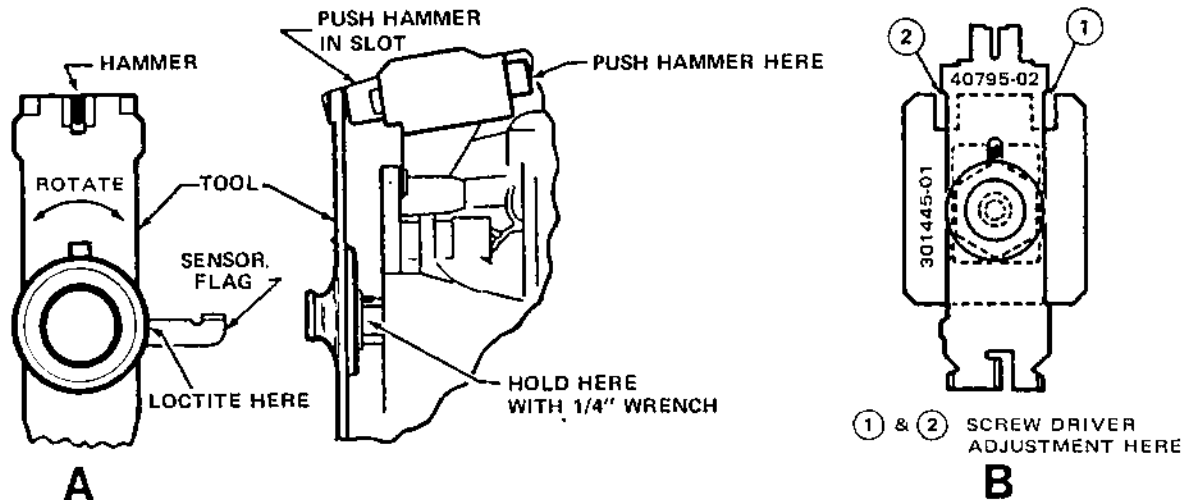

Figure 5-28 PRINT WHEEL TO HAMMER ALIGNMENT

Early versions of the Series 1300 HyType II Printer use a print wheel hub assembly which relies on quick setting adhesive to fix or bond the wheel alignment tab/flag in position on the hub. These assemblies may use either the #40795, or the #40795-02 Alignment Tool, as follows:

Bonded Hub Alignment.

Refer to Figure 5-28(A), and to subsection 5.4.2.3.

- # Apply power to the printer and allow the printer to complete the RESTORE sequence. Remove paper, ribbon cartridge and the print wheel. Install the alignment tool firmly on the print wheel motor shaft hub, and ensure that it is properly seated with its alignment slot (B1) engaged over the tab on the hub's alignment plate.
- # Rotate the tool to bring its hammer slot (B2) in front of the print hammer, and then block the carriage home sensor's light path (by inserting a piece of dark paper into its slot) to detent the print wheel motor.
- # Manually push the print hammer in toward the alignment tool gently, until its face enters the tool's hammer slot (B2). If the hammer face slides easily into the tool slot without contacting the sides of the slot, print wheel-to-hammer alignment is correct. If the hammer contacts the sides of the tool slot or will not enter the slot at all, continue with this procedure.

Place a 1/4" open end wrench on the print wheel motor shaft nut, and prevent the shaft from turning. Move the alignment plate by means of the Adjustment Tool ONLY as necessary to achieve proper print wheel alignment with the print hammer.

CAUTION: In this step the tool is moving the print wheel alignment plate on the motor shaft where these parts have been previously bonded together with adhesive. DO NOT flex or bend the alignment plate's tab or flag - USE THE TOOL to apply the pressure to break the bond and move the plate. Rebond with adhesive (see Item 7, subsection 5.2.2) when alignment has been completed.

NOTE #1: If repositioning of the alignment plate was required, it will be necessary to check the Print Wheel Home adjustment.

NOTE #2: The adhesive specified must be kept properly stored (at 50^o_F) and used while fresh ONLY for proper bonding. The material deteriorates rapidly after exposure to the air or temperatures above 50^o_F.

Current production versions of the Series 1300 HyType II Printer include a mechanical print wheel hub which uses a special compression washer to maintain proper positioning of the print wheel alignment plate. These versions make use of the #40795-02 and #301445-01 Adjustment Tools as follows:

Mechanical Hub Alignment

Refer to Figure 5-28(B), and to subsection 5.4.2.3.

- # Apply power to the printer and allow the printer to complete its RESTORE sequence. Remove paper, the ribbon cartridge and the print wheel.
- # As shown, install Adjustment Tool #301445-01 over the nut on the front of the print wheel hub. Install Adjustment Tool #40795-01/-02 firmly on the print wheel motor shaft hub and ensure that it is properly seated with its alignment slot (B1) engaged over the tab on the hub's alignment plate.
- # Rotate the alignment tool to bring its hammer slot (B2) in front of the print hammer, and then block the carriage home sensor's light path (by inserting a piece of dark paper into its slot) to detent the print wheel motor.
- # Manually push the print hammer gently toward the alignment tool until its face enters the tool's hammer slot (B2). If the hammer face slides easily into the slot without contacting the sides of the slot, Print Wheel To Hammer alignment is correct. If the hammer contacts the sides of the slot or will not enter the slot at all, continue with this procedure.
- # Place the tip of a blade screwdriver in either of points 1 or 2. The screwdriver may then be twisted to move the alignment plate in relation to the print wheel hub to achieve proper alignment.

CAUTION: Carriages with the mechanical print wheel hub DO NOT require use of any adhesive.

5.4.4.6 Print Wheel Home Adjustment

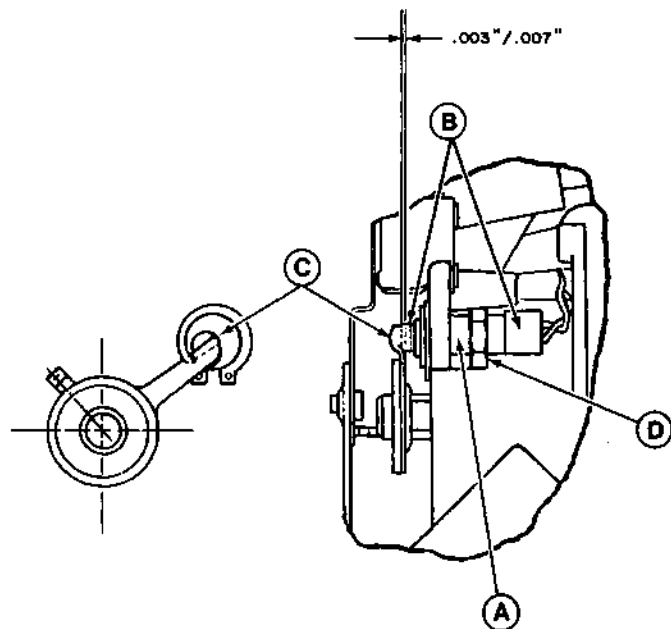

Figure 5-29 PRINT WHEEL "HOME" ALIGNMENT

The printer's print wheel logic includes a safety feature called retry. This feature helps, during the RESTORE sequence, to ensure that the microprocessor has the right count in its absolute counter for print wheel position. The print wheel is allowed to stop only at those points where the +PW EVEN is HI which occurs only once per print wheel or petal position. If the print wheel fails to stop in a position where +PW EVEN=HI, the microprocessor will reissue the print wheel portion of the RESTORE sequence. The print wheel restore sequence will retry stopping the print wheel in a proper position. If the microprocessor is unable to obtain the correct condition after 8 consecutive attempts (retries), it will issue a CHECK command to stop the printer. This situation normally indicates that a print wheel home adjustment is needed.

- # Remove the ribbon cartridge, and tilt the print wheel motor forward away from the platen.
- # Initiate a RESTORE sequence. Verify that the correct home character has been positioned squarely in front of the print hammer. Home characters for the various models are:
 - Model 1345A = E
 - Model 1355HS =
 - Model 1355WP = 90° flag notch

If the home character is displaced less than one character width, perform a print wheel to hammer alignment per subsection 5.4.4.5.

If the home character is displaced one full character position, perform the print wheel home adjustment procedure outlined below.

If the home character is displaced more than one full character position, perform both the print wheel alignment and the home position alignment procedures. In this event, perform the wheel alignment first.

Print Wheel Home Alignment

Refer to Figure 5-29.

- # Use a 7/16" open end wrench to adjust the home sensor eccentric (A) as follows. Move the eccentric slightly in either direction, and RESTORE the printer. Continue adjusting the eccentric in that direction, a little at a time, until the print wheel spins (8 revolutions) and the printer goes into its CHECK mode. Note this eccentric position.
- # Move the eccentric in the opposite direction in the same manner until the printer goes into CHECK again. Note this eccentric position.
- # The two extremes noted above may be as much as 180° apart. Adjust the eccentric to the approximate midpoint between these two extremes.
- # If the print wheel spins continuously (8 revolutions), the sensor (B) may be located too far from the print wheel home sensor flag (C). Loosen nut (D) and rotate the sensor clockwise until the print wheel stops. Use a plastic shim to verify .003" to .007" clearance between the surface of the sensor and the edge of the flag. Retighten nut (D).

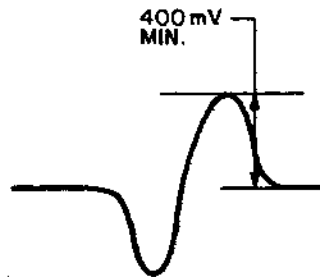

Figure 5-30
PRINT WHEEL HOME SENSOR WAVEFORM

#The electrical signal out of the sensor should be at least 400mV peak. Figure 5-30 illustrates this signal, as seen at the input to the Print Wheel Home Sensor amplifier on the SERVO PCB.

5.4.4.7 Hammer Adjustment

Refer to Figures 5-31 and 5-32.

- # Remove power from the printer. Remove ribbon cartridge and any paper. Move the platen position lever fully forward. Verify that the platen is in good condition and free of surface defects. If this is to be an adjustment for high print quality, installation of a new platen (if even temporarily) should be entertained.

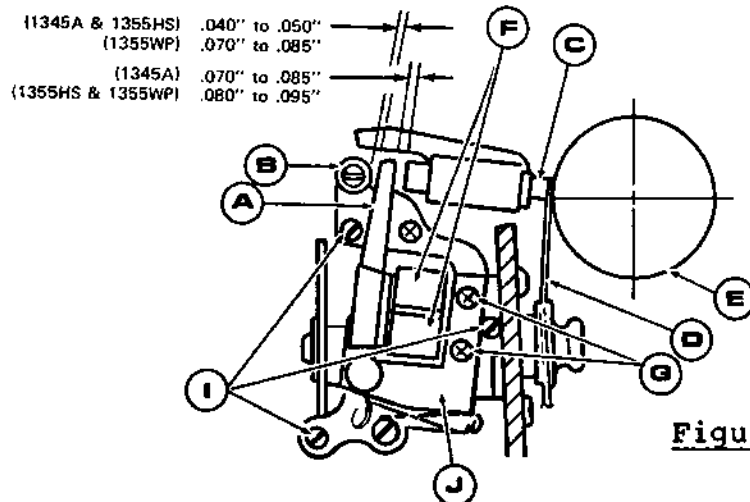

Figure 5-31 HAMMER ADJUSTMENTS

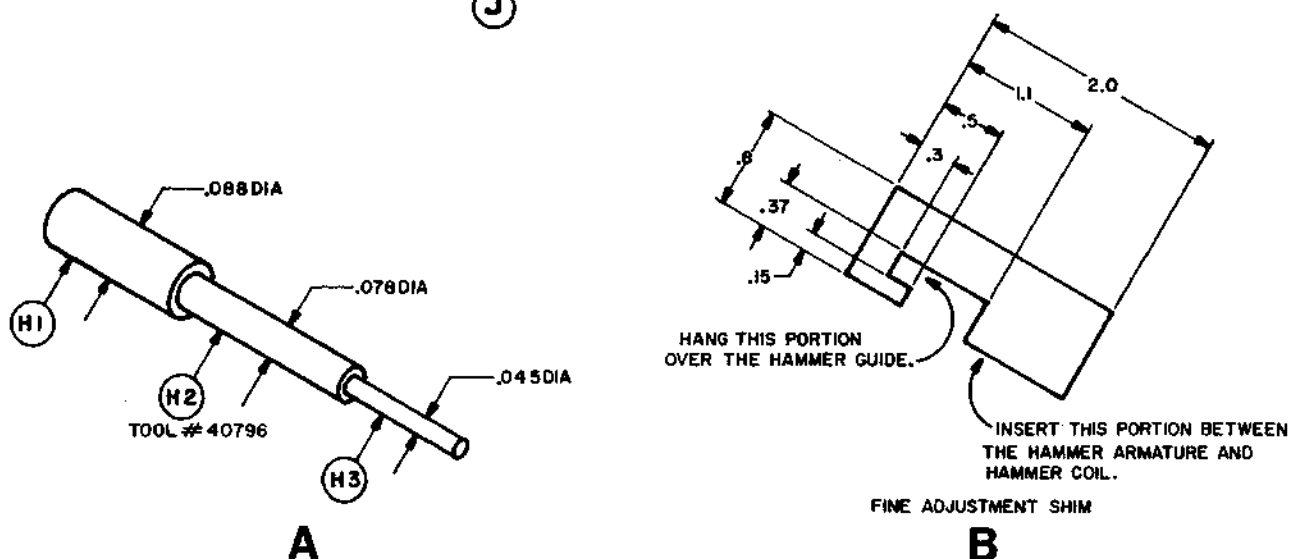

Figure 5-32 HAMMER ADJUSTMENT TOOL #40796 and SHIM

Hold the hammer armature (A) against the hammer coils (F), and check for no gap between them. Insert Adjustment Tool #40796 between the armature (A) and the armature stop eccentric (B) as follows:

- Model 1345A - use part H3
- Model 1355HS - use part H3
- Model 1355WP - use part H2

Adjust the eccentric (B) as necessary for a very light resistance to passage of the tool when slid along the side of the armature past the eccentric.

Rotate the print wheel manually to place one of the larger characters (M,W,E, etc.) in front of the print hammer. If this is to be an adjustment for high quality use of a new print wheel (if even temporarily) should be entertained. Insert Adjustment Tool #40796 between the armature (A) and the anvil end of the print hammer (C) as follows:

- Model 1345A - use part H2
- Model 1355HS - use part H1
- Model 1355WP - use part H1

With the tool in place, lightly press in on the armature (A) until it stops against the hammer coils (F). This will drive the print hammer (C) in to nestle the selected print wheel petal (D) lightly against the platen (E). Gently rock the print wheel slightly back and forth, and verify that the petal can move with a very light drag. Repeat this check while rotating the platen and moving the carriage each time until the entire printing surface condition has been checked. Adjust the hammer armature assembly to achieve these goals as follows:

Model 1345A - Adjust the print hammer coils (F) to achieve best hammer to platen dimensions by loosening screws (G) and moving the coils and the armature. Retighten screws (G).

Models 1355HS and 1355WP - Adjust the print hammer armature assembly (J) to achieve best hammer to platen dimensions by loosening screws (I) and moving the assembly. Retighten screws (I).

NOTE: It may be necessary to slightly readjust the carrier system platen to print wheel dimension to achieve the conditions specified above. Refer to subsection 5.4.4.3.

Print Quality Fine Adjustment Hint

Refer to Figure 5-32(B). To fine adjust the print quality on the Series 1300 HyType II Printer, a .005" plastic shim, as shown in Figure 5-32(B), may be placed between the hammer armature and hammer coil. The shim will decrease hammer energy significantly. This will in turn amplify nonuniform print density for easy adjustment.

The fine adjustment shim may be cut from .005" plastic shim stock (Diablo P/N 41144-07 or equivalent) using the pattern shown. In addition, always use a multistrike carbon film ribbon for print quality adjustments.

5.4.5 Carriage Drive System

This subsection outlines the replacement and adjustment of the carriage drive system, which includes the carriage servo motor and the carriage drive cable.

5.4.5.1 Carriage Drive Cable Removal

- # Disconnect the carriage drive pulley and remove the carriage rail clamps, as described in Steps 7 and 8 of subsection 5.4.4.1. Do not disturb the spring shielded interconnecting cables.
- # Raise the carriage and rails up together, and carefully lay them back on top of the printer. Do not slide the rails out of the carriage sleeve bearings.
- # Refer to Figure 5-33. Use a TORX T15 screwdriver to loosen the mounting screw and release the drive cable tension leaf spring, located on the left-hand side of the printer's main frame. This will release tension on the carriage drive cables.

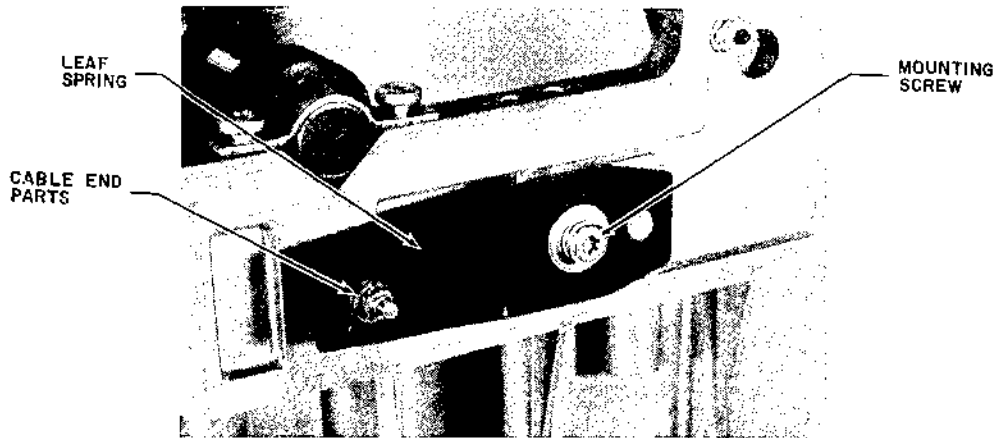

Figure 5-33 DRIVE CABLE TENSION SPRING

- # Remove the hemostat, retrieve the carriage drive pulley, and unthread the two drive cable sections. Note that the ball end of the left-hand cable is trapped between the servo motor's drive capstan and the printer's main frame. Release the ball end from its groove in the capstan, and extend the cable down below the lower part of the capstan and to the right to free it for removal.
- # If the carriage servo motor is not to be removed, skip to subsection 5.4.5.3 below.

5.4.5.2 Carriage Servo Motor Replacement

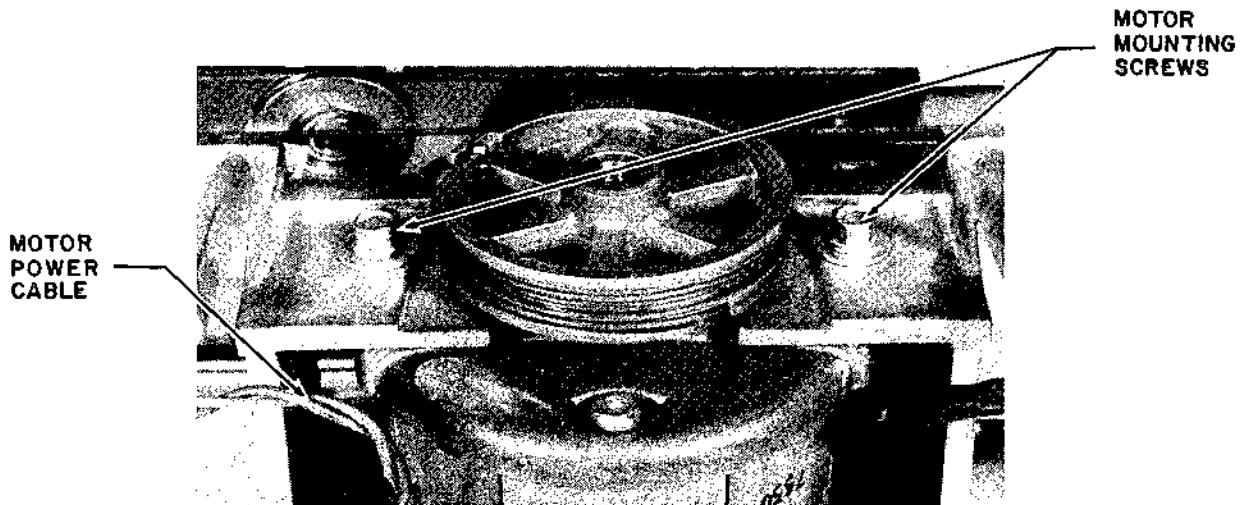

Figure 5-34 CARRIAGE SERVO MOTOR MOUNTING SCREWS

To remove the motor:

- # Temporarily return the carriage and its rails to the operating position, and install the rail clamps and screws - with the screws threaded in finger tight only.

- # Stand the printer up on the front end of its main frame, remove the four 8-32 screws holding the bottom plate in place, using a TORX T15 screwdriver. Move the plate back out of the way.
- # Cut the cable ties to open the wire bundles, unplug and release the servo motor's transducer and power cables. Note their arrangement for later reassembly.
- # Using a 1/4" wrench, remove the two 8-32 hex head thread forming screws and #8 flat washers holding the motor to the printer's main frame, and remove the motor and its attached cables. Note the orientation of motor and cables for reassembly.

To replace the motor:

- # On the replacement carriage servo motor, lightly coat those surfaces which will contact the printer's main frame with thermal compound.
- # Orient the motor with its drive capstan up, and its 2-wire power cable to the left (as you view it) as observed above during removal, and move it into position in the main frame.
- # Use a 1/4" wrench to replace the two 8-32 hex head thread forming screws and #8 flat washers, to hold the motor in place. Start the screws, then pull the motor as far toward you as possible (toward the bottom of the printer), and tighten the screws down firmly.
- # Arrange the two cables into their respective positions and secure the wire bundles with cable ties. Plug the cables into their PCB connections.

NOTE: If the bottom plate retains the metal clips used to secure the two carriage motor cables, remove and discard these clips. Replace the clips with cable ties.

- # Move the bottom plate back into position, and replace the four 8-32 screws to hold it in position.
- # Return the printer to its normal position.

5.4.5.3 Carriage Drive Cable Replacement

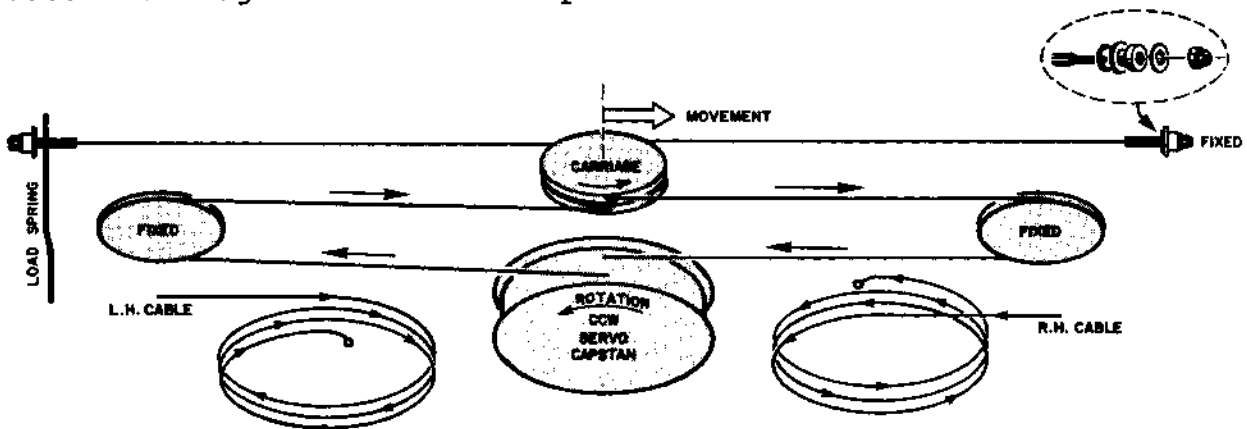

Figure 5-35 CARRIAGE CABLE DRIVE SYSTEM SCHEMATIC

Refer to Figure 5-35.

- # Study the arrangement of the cable drive system depicted in the illustration.

- # Assemble an "O" ring, cable hub, #6 lock washer and 5-40 locknut on the end of one of the replacement carriage drive cables. Screw the nut onto the cable shank far enough to allow a thread or two to show on the free side of the nut. Hold the cable shank securely with a wrench while driving the nut on, to avoid twisting the cable.
- # Insert the ball end of this cable through the cable hole in the right-hand end of the printer's main frame. Engage the cable end ball in the notch on the outside rim (away from you) of the servo motor's capstan.
- # Hold slight tension on the cable, and turn the capstan counter-clockwise (as you view it) to wind on almost all of the cable (slightly more than 4 turns).

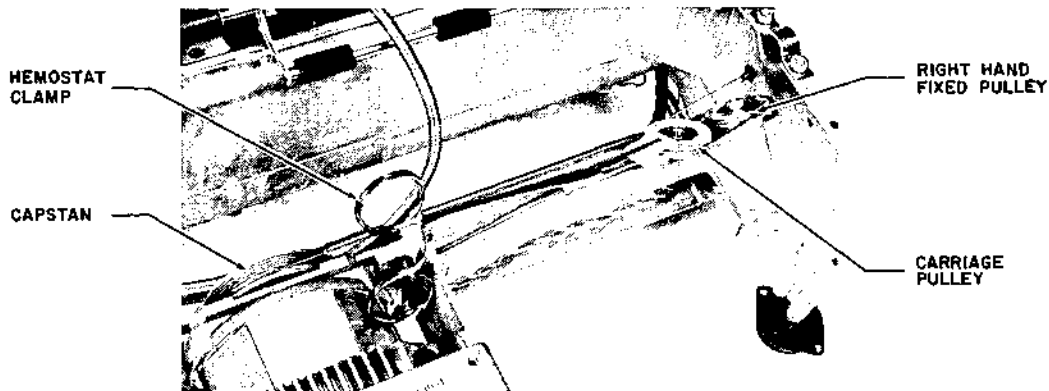

Figure 5-36 RIGHT-HAND CARRIAGE DRIVE CABLE INSTALLATION

Refer to Figure 5-36.

- # From the capstan, arrange the cable back to the right around the right-hand fixed pulley clockwise (bottom rear to top front), and back to the left and clockwise (front to back) around the carriage pulley, with this cable in the carriage pulley's top groove. It will be necessary to allow the capstan to rotate slightly.
- # Protect the carriage pulley with heavy paper, and grasp it with the hemostat clamp as shown in Figure 5-36. Hook the hemostat clamp's lower finger ring over the main frame servo motor shield as shown, where the motor's magnetism will help to hold it in position. Rotate the capstan counterclockwise to keep a slight tension on the cable, and to locate the notch on the capstan's inside rim (toward you) as near the top (as you view it) as possible.
- # Work the ball end of the second replacement cable down beside the capstan (either side) and back up between the capstan and the main frame. Engage the ball in the rim notch.
- # Arrange the cable back from the capstan to the left around the left-hand fixed pulley counterclockwise (bottom rear to top front), and back to the right. Carefully insert the cable end under the carriage pulley front to back and then back to the left, engaging the cable in the carriage pulley's bottom

groove. Stretch the cable to the left, and thread its free end out through the cable hole in the left-hand side of the printer's main frame.

- # Assemble the following items on the free end of this second cable shank as it protrudes out beyond the side of the frame, in the order listed as shown in Figure 5-37. Put the locknut on finger tight only, and avoid twisting the cable.

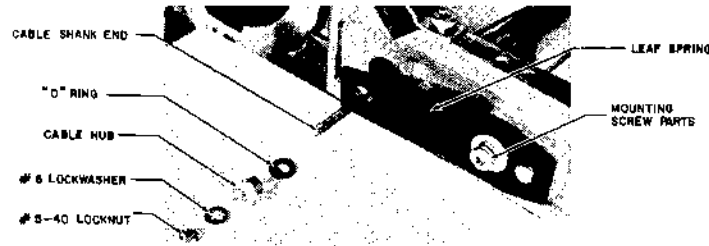

Figure 5-37 CARRIAGE DRIVE CABLE TENSION SPRING ASSEMBLY

Refer to Figure 5-37.

- # Assemble the 8-32 x .625" screw, #8 flat washer, and #8 lock washer. Insert the screw through the leaf spring and into the main frame as shown. Use a TORX T15 screwdriver to tighten down on the screw enough to apply a light spring tension to the cables.
- # Insert the small end of the TORX screwdriver down through the hub of the carriage pulley (to prevent the pulley from flipping over which would release the two cables) and carefully release the hemostat clamp.
- # Hold the TORX handle upright, and gently rotate the servo motor drive capstan clockwise to move the carriage pulley left, to a position just to the right of the carriage servo drive motor, where the pulley hub is accessible up through the bottom of the printer alongside the motor. Install the hemostat clamp (with heavy paper protector for the pulley) as shown in Figure 5-17(B), and remove the TORX screwdriver.
- # Reinstall the carriage and rails, and attach the drive cable pulley as outlined in subsection 5.4.4.2, Steps 7, 8 and 9.

5.4.5.4 Carriage Drive Cable Adjustment

Refer to Figure 5-38.

- # With the carriage positioned against the left-hand mechanical stop, check the cable tension midway along the exposed cable for the force necessary to distort the cable as shown.

NOTE: If the Tensiometer, listed as part of the recommended tools in subsection 5.2.3, is not used, the dimensions between the force points shown must be carefully followed.

- # Adjust cable tension by tightening or loosening the cable tension nut (B).

WARNING: The square shank on the end of the cable (A) must NOT be allowed to rotate while adjusting the nut (B).

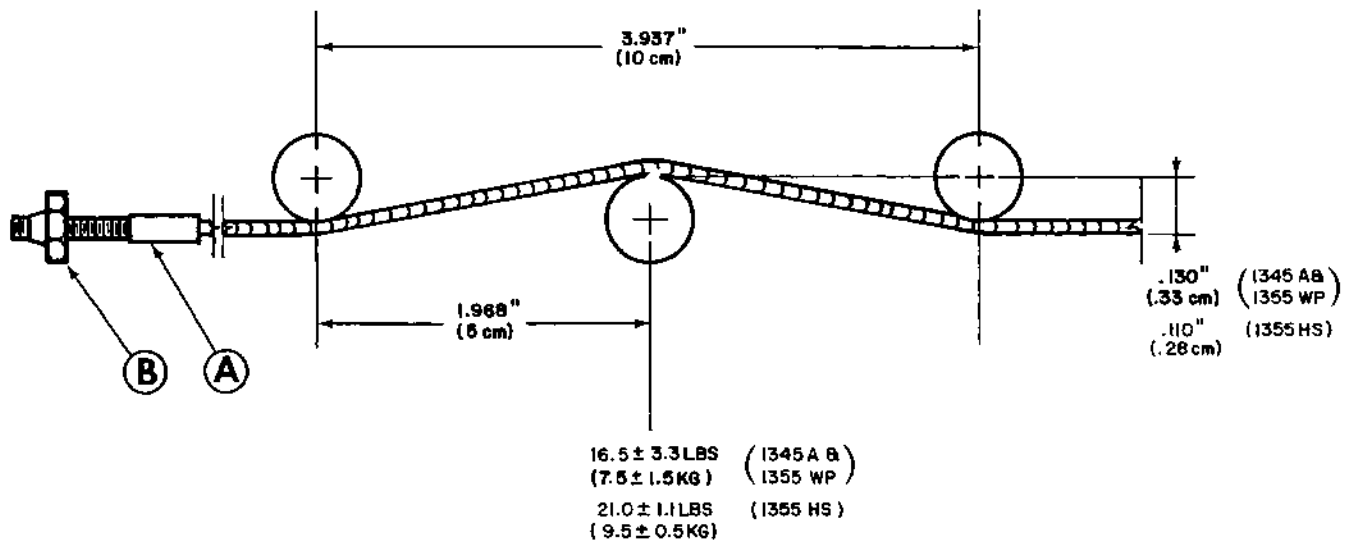

Figure 5-38 CARRIAGE DRIVE CABLE ADJUSTMENT

After adjusting the nut (B), move the carriage back and forth several times to redistribute cable tension, and check again. Readjust as necessary to achieve the conditions shown. Use bonding adhesive (subsection 5.2.2, Item 7) on the locknuts on the ends of both cables after adjustment has been completed.

5.4.6 Motherboard Replacement

1. Remove power, and disconnect the printer completely.
2. Move the printer to a sturdy work bench or table. Remove any covers.
3. Remove the PCB clamp. Disconnect and remove all the plug-in PC boards. Remove the ribbon cartridge.
4. Stand the printer up on the front end of its main frame, with the bottom facing front.
5. Disconnect all interconnecting wires and cables going to the Motherboard.
6. Remove the top left-hand (as you view it) shock mount, if installed.
7. Use a TORX T15 screwdriver to remove the 8-32 screws holding the Motherboard to the main frame - three on the left-hand (as you view it) end for the power plug supports, and six along the bottom. Remove the Motherboard assembly.
8. Reverse the first seven steps to install a Motherboard.

5.4.7 Bottom Feed Paper Chute Option - Assembly, Installation and Adjustment

The following paragraphs detail the installation and adjustment of the optional Bottom Feed Paper Chute. These procedures will require use of an Xcelite #99-20 hex type screwdriver and a TORX T15 screwdriver or their equivalent, and a small blade screwdriver.

5.4.7.1 Assembly Procedures

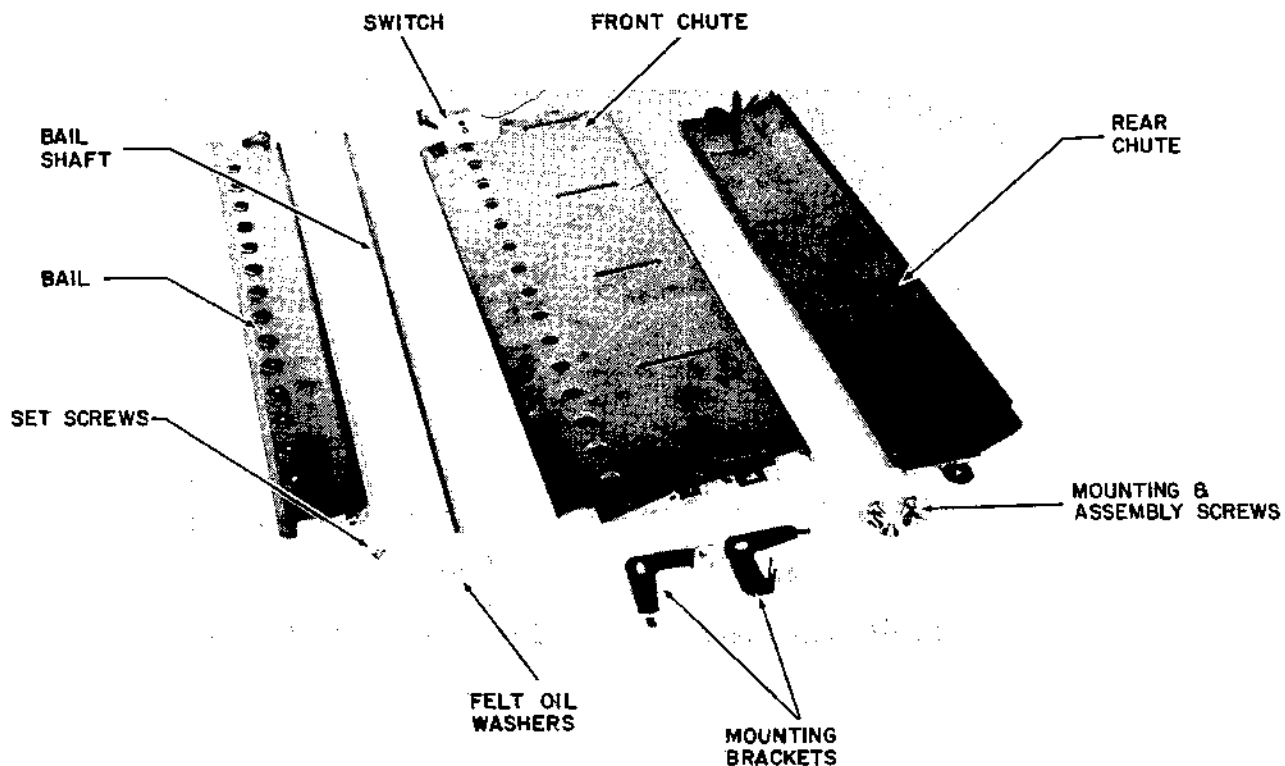

Figure 5-39 BOTTOM FEED PAPER CHUTE ASSEMBLY PARTS

1. Assemble and identify the various parts needed for installation of this part of the option, as shown in Figure 5-39.
2. Study Figure 5-40. Lay the bail on the front chute as shown. Insert the bail shaft in the bail hubs. Place a felt oil washer on each end of the bail shaft, and saturate the felt with light oil. Carefully work the shaft ends into the holes in the front chute tabs. Insert a 4-40 x .187" setscrew into each bail hub, center the bail shaft, and tighten the setscrews.
3. Study Figure 5-41. Lay the rear chute on the lower part of the front chute. Drive two 8-32 x 1/4" thread forming screws through the lower slots in the front chute into the holes in the rear chute. Make sure the bottom (flared) edges of the two chute parts are even, and tighten the two screws.

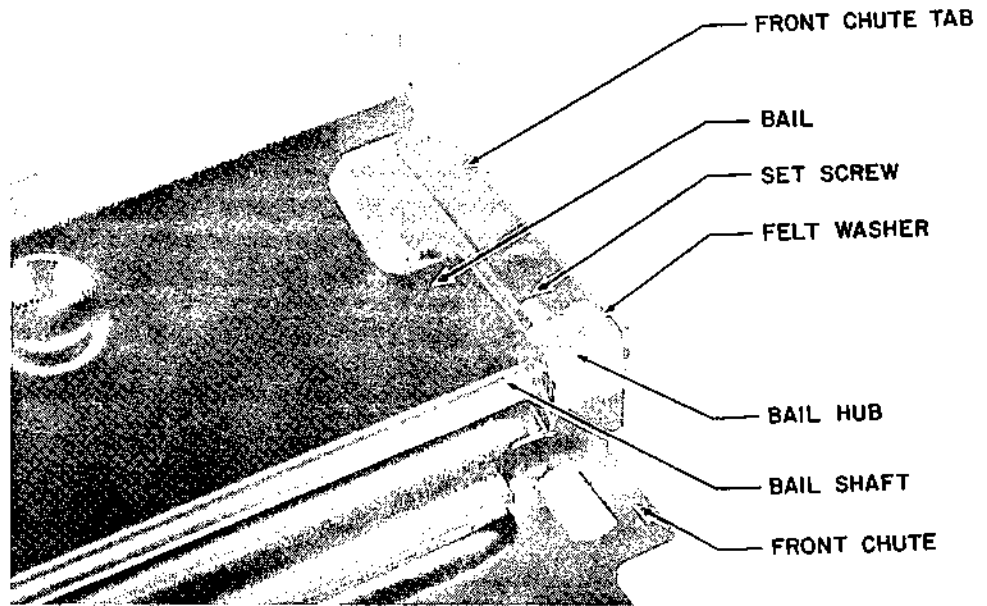

Figure 5-40 BAIL AND FRONT CHUTE ASSEMBLY

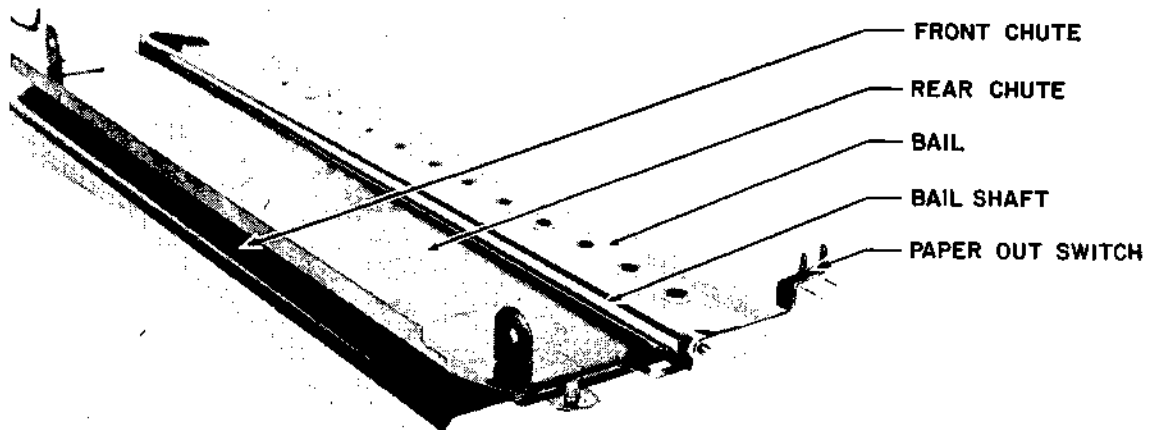

Figure 5-41 REAR TO FRONT CHUTE ASSEMBLY

4. Mount the paper out switch on the front chute's left end tab, using two #2-56 x 1/2" slot head screws and a nut plate. Make sure the switch's actuator arm is outside the bail. Adjust the switch location so that a single sheet of paper inserted down the throat of the paper chute will actuate the switch, and tighten down the mounting screws.

NOTE: If the switch is NOT to be used, replace it with the bail locking block shown in Figure 5-43, and disregard subsection 5.4.7.2 Step 7, and subsection 5.4.7.3 Steps 6 and 7 below.

5.4.7.2 Installation Procedures

1. Remove the ribbon cartridge, print wheel, platen and paper cradle as required. If necessary, remove the printer from its operating position, and move it to a work bench or table. If the front cover open switch option is installed, dismount it and tie it back out of the way.
2. Stand the printer up on the front end of its main frame. Examine the passageway through the main frame into which the bottom feed paper chute will be placed, located just to the rear (up - as you view it) of the narrow bottom plate. Make sure the spring shielded cables from the carriage and other wire bundles are not blocking the opening.
3. Remove the 8-32 x 1/4" thread forming screw holding the two ground wires to the main frame near the left-hand (as you view it) end of the main frame, and bend the wires out of the way.
4. Hold the paper chute assembly bail up, and carefully work it into position in the printer's main frame. It may be necessary to move the carriage from side to side to aid in working the chute into position.
5. Reinstall the screw, and ground wires, removed in Step 3 above through the hole in the chute flange. Install a second 8-32 x 1/4" thread forming screw through the hole in the flange at the opposite end of the chute into a hole in the main frame casting. These two screws hold the bottom of the paper chute in place in the printer's main frame.

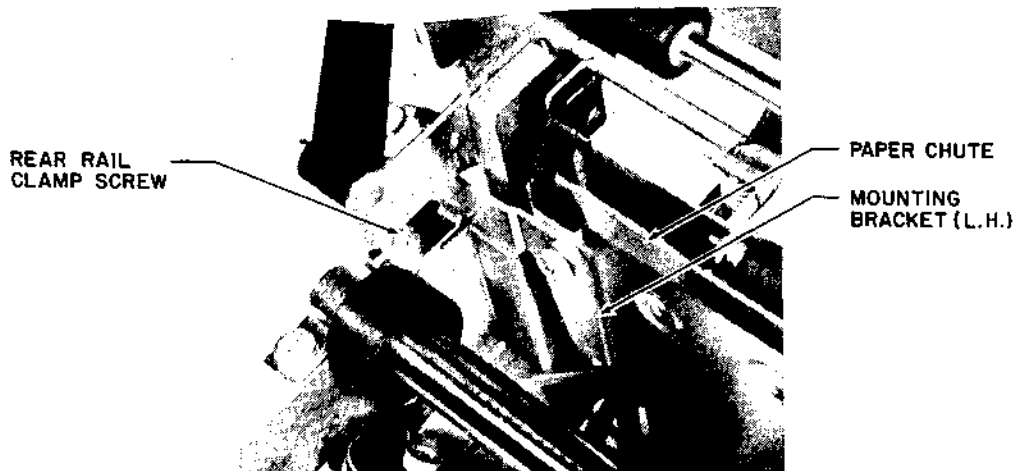

Figure 5-42 UPPER PAPER CHUTE MOUNTING BRACKET INSTALLATION

6. Return the printer to its upright position. Study Figure 5-42. The top of the paper chute is held in place with two mounting brackets

with the left hand bracket installation being shown in Figure 5-42. Loosen the rear rail clamp screw at each end of the rear carriage rail. Each bracket is installed by working it in under the platen paper bail mechanism, with its slotted end under the carriage rail clamp screw and its lower tab inserted in the slot provided near the edge of the paper chute itself. Each bracket is then fastened to the paper chute with an 8-32 x 1/4" thread forming screw.

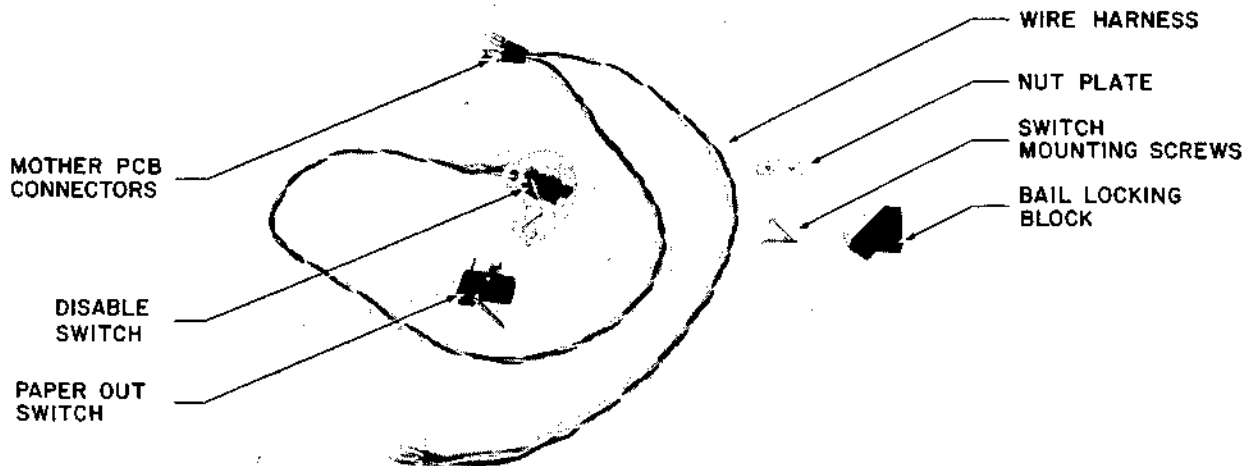

Figure 5-43 BOTTOM FEED PAPER CHUTE PAPER OUT SWITCH PARTS

7. Assemble and identify the parts needed for installation of this portion of the Bottom Feed Paper Chute. Note that either the paper out switch or the bail locking block should have been installed earlier. Figure 5-43 illustrates these parts.

8. Install the paper out disable switch under the left-hand front carriage rail clamp screws - on top of the rail clamp itself. Route the switch's 2-wire harness down alongside the carriage home sensor cable to the rear of the main frame cavity and out to the Motherboard. Connect the wire harness's large slip-on connectors (2 wires each) to Motherboard terminals T8 and T9. Route the remaining two wires back to the left and up through the printer's center cavity, where they should pass over the top of the paper release lever's torque shaft and forward under the paper carrier's main frame to connect to the paper chute's switch terminals. Secure the wires to the torque shaft with a cable tie, and also to the other wire bundles along their path from the paper out disable switch.

5.4.7.3 Adjustment Procedures

1. The following adjustments must be correct before adjusting the Bottom Feed Paper Chute:

- # Platen Position
- # Paper Feed
- # Card Guide

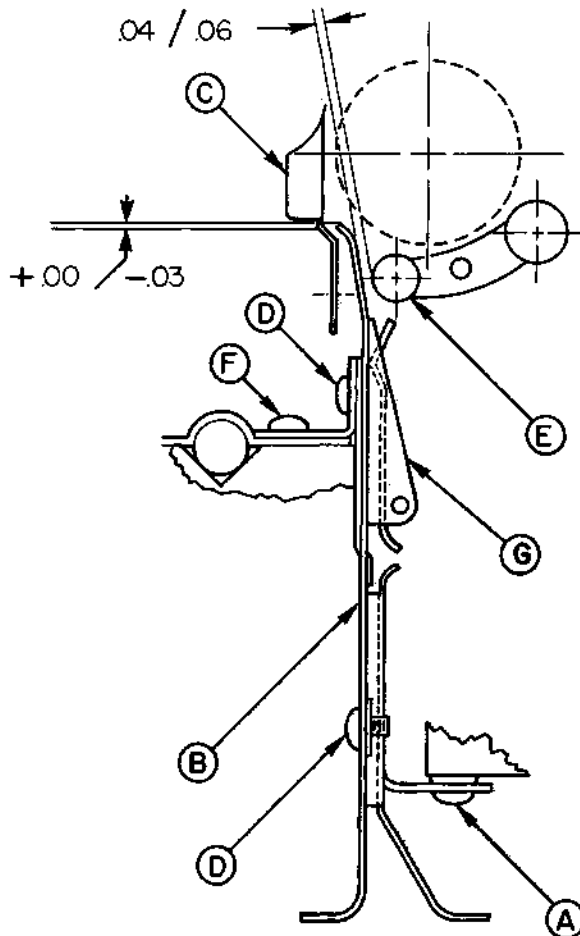

Figure 5-44
BOTTOM FEED PAPER CHUTE ADJUSTMENTS

2. Move the Paper Release and Platen Position levers fully forward. Make sure all paper chute screws are loose, except those for the paper out switch and the front chute bottom bracket (Figure 5-44 Item A).

Refer to Figure 5-44.

3. Adjust the front paper chute (B) up or down to achieve the location shown level within $+.00/-0.03$ " with the top 45° bend of the card guide (C) the entire length of the carriage travel. Tighten screws (D) on each end.

4. Adjust the clearance between the front pressure rollers (E) and the upper surface of the paper chute (B) for $.05" \pm .01"$. Tighten screws (F) on each end.

5. Adjust the paper bail (G) as necessary so that its dimples contact the front paper chute evenly at both ends, and tighten the set-screws in its hubs.

6. Adjust the paper out switch to reset $.025"$ to $.040"$ before the paper bail dimples touch the front chute (B).

7. Check for bail minimum movement of .100" beyond tangent point of the dimples on the chute and on the bail. Reform the switch arm and readjust the switch as required.

NOTE: The bail must move freely.

5.4.8 #24460 Top Paper Out Switch Option

The following paragraphs detail the installation and adjustment of the optional Top Paper Out Switch. These procedures will require the use of an Xcelite #99-20 hex type screwdriver or equivalent, a small size (3/16" or 1/8") long shanked blade screwdriver or equivalent, long nose pliers, and adhesive (subsection 5.2.2 Item 7).

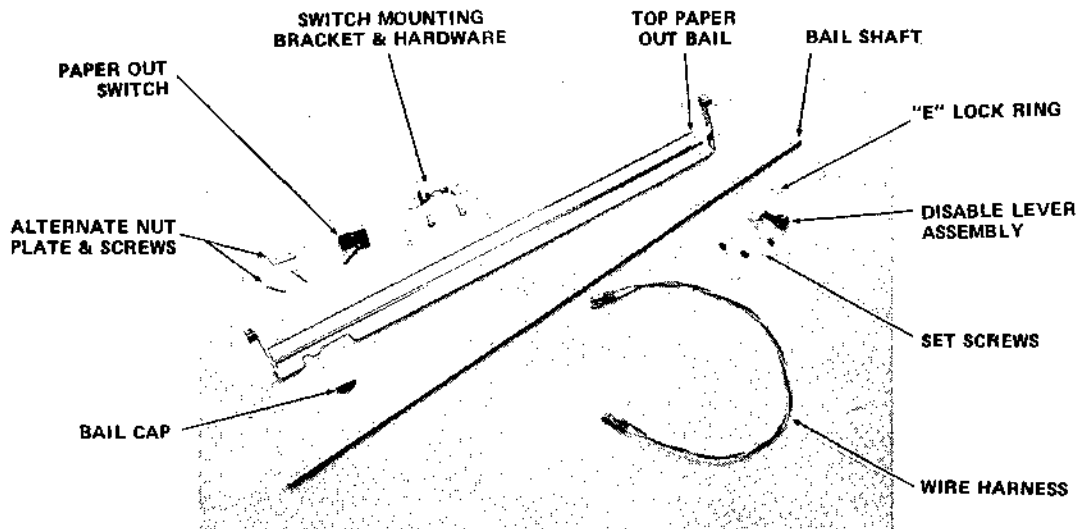

Figure 5-45 TOP FEED PAPER OUT SWITCH ASSEMBLY PARTS

Assemble and identify the various parts needed for installation of this option, as shown in Figure 5-45.

5.4.8.1 Switch Mounting - Bracket Installation

Current production of the Series 1300 HyType II Printer provides for mounting the Top Paper Out Switch on the Paper Carrier main frame member using a special bracket. Threaded holes are provided in the main frame member for mounting this bracket.

Refer to Figure 5-46(A).

1. Assemble the Top Paper Out Switch in the bracket as shown, with the bracket tabs inserted in the switch's mounting holes. Place this assembly on top of the carrier main frame member in position over the threaded holes.

2. Secure the bracket and switch in place with two 4-40 x 3/8" screws, #4 lock washers and #4 flat washers.

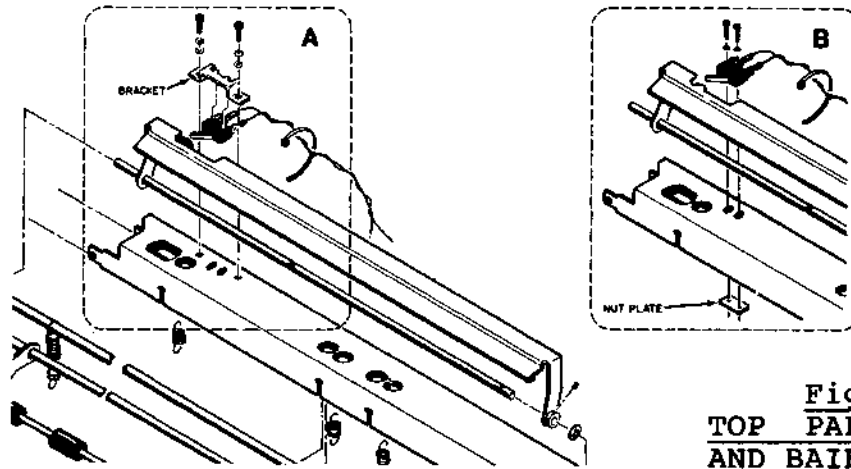

Figure 5-46
TOP PAPER OUT SWITCH
AND BAIL INSTALLATION

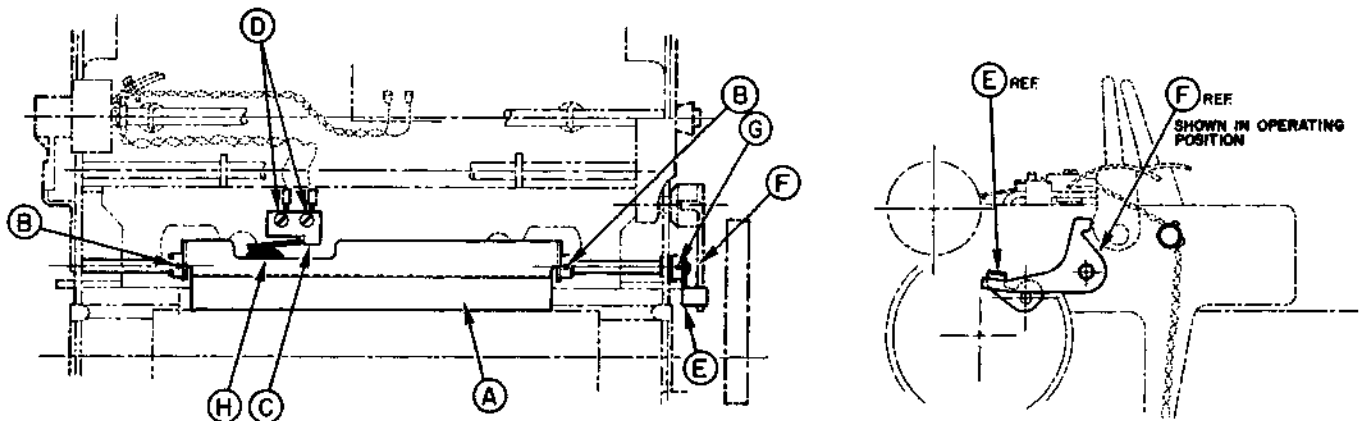

Figure 5-47 **TOP PAPER OUT SWITCH AND BAIL INSTALLATION LOCATIONS**

5.4.8.2 Alternate Switch Mounting - Nut Plate Installation

Earlier production of the Series 1300 HyType II Printer provided for mounting the Top Paper Out Switch on the Paper Carrier main frame member using a nut plate located inside the frame member.

Refer to Figure 5-46(B).

1. Place the Paper Out Switch in position on top of the Paper Carrier main frame over the two slotted mounting holes. The switch must be oriented with its actuator toward the left front as shown.
2. Stick the nut plate in a flat lengthwise position on the end of the long shanked flat blade screwdriver, using any type of sticky tape.
3. Carefully insert this 'tool', with nut plate attached, into the left end of the carrier frame far enough for the nut plate's screw holes appear under the switch's mounting holes.
4. Carefully thread the two 2-56 x 1/2" screws (with #2 washers) down through the switch and frame slots into the screw holes in the nut plate. After the screws are securely threaded into the nut plate

holes withdraw the screwdriver and tape. Tighten the screws down finger tight only, with the switch pushed as far back toward the rear of the printer as possible.

5.4.8.3 Top Paper Out Switch Bail Installation

Refer to Figure 5-47.

1. Thread two of the setscrews into the hubs (B) on the paper out bail (A).
2. Install the bail cap (H) on the tab on the left rear edge of the paper out bail using the adhesive specified in subsection 5.2.2 Item 7.
3. Lower the paper out bail down over the carrier assembly behind the platen, with the bail's end pieces extending down into the carrier, and the bail cap at the left rear adjacent to the paper out switch installed earlier. Push the switch actuator arm back to clear the bail cap.
4. Insert the paper bail shaft (grooved end first) into the carrier and bail assemblies, left to right, through the hole in the left-hand carrier side plate, the left-hand paper bail hub (B), through the length of the carrier assembly, through the right-hand paper bail hub (B), and out through the hole in the right-hand carrier side frame.
5. Install the E retainer ring in the bail shaft groove, now located just inside the right-hand carrier frame.

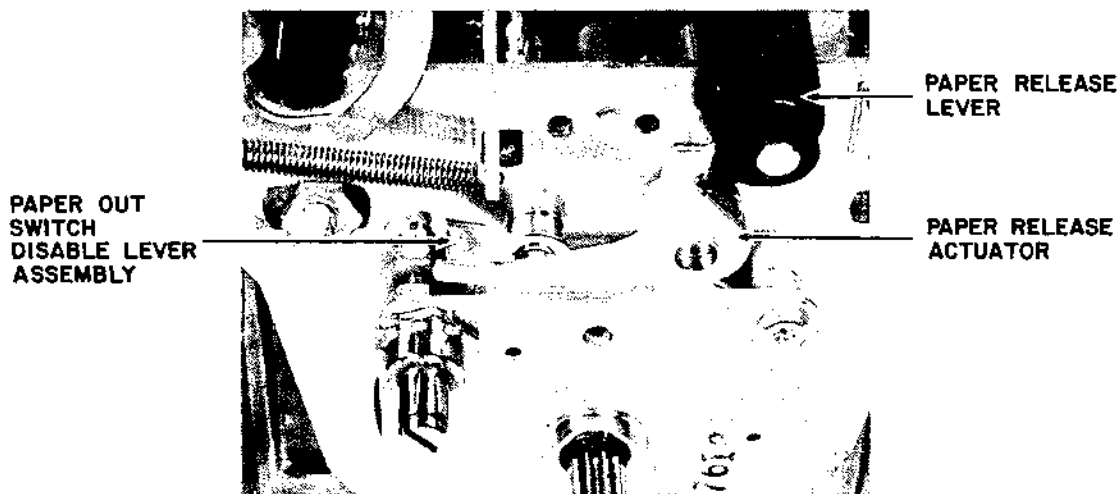

Figure 5-48 TOP PAPER OUT SWITCH DISABLE ASSEMBLY

Refer to Figure 5-48.

6. Thread a setscrew into the hub of the disable lever assembly (E), and place this assembly over the right end of the bail shaft so that its tab extends out over the paper release actuator arm, as shown. Tighten the setscrew only enough to keep the assembly from falling off the end of the shaft.

7. With the shaft pushed to the right to bring the E ring up against the right-hand carrier side frame, center the paper bail in the carrier frame and tighten the two bail hub (B) setscrews.

5.4.8.4 Top Paper Out Switch Adjustment

1. Remove the platen, and move the paper release lever fully rearward.
2. Manually hold the paper out bail (A) back toward the rear as far as it will go, with both bail arms resting against the carrier assembly main frame.
3. Loosen and reset the bail hub setscrews to remove any tension and/or twisting forces.
4. Still holding the bail back, rotate the disable lever assembly to bring its extended tab into light contact with the top surface of the paper release actuator arm. Adjust the disable assembly laterally on the shaft end for a maximum clearance of .005" between its hub and the carrier side frame. Tighten the disable assembly's setscrew.
5. Loosen the paper out switch (or switch bracket) mounting screws and adjust the location of the switch so that the switch actuator arm, being pushed back by the paper bail, clears the switch body and the paper bail also clears the switch body. Tighten the mounting screws.
6. Install the platen, and bring the paper release lever fully forward. The paper out bail should move forward to contact the platen squarely along its length within .015", and should not be bowed vertically more than .030". Reform the bail as necessary to achieve these goals.
7. Check that the paper out switch opens when the paper out bail approaches to within .035" of the platen. If the switch opens when the bail is more than this distance from the platen, reform its actuator arm to place the switchover point within the limit specified.

5.4.9 #40504-XX Cover Open Switch Option - Installation and Adjustment

The following paragraphs detail the installation and adjustment of the optional front mounted Cover Open Switch, and include the adjustment of the earlier side mounted switch installation. These procedures will require the use of a TORX T15 screwdriver, and a small blade screwdriver.

Assemble and identify the various parts needed for installation of this option, as shown in Figure 5-49.

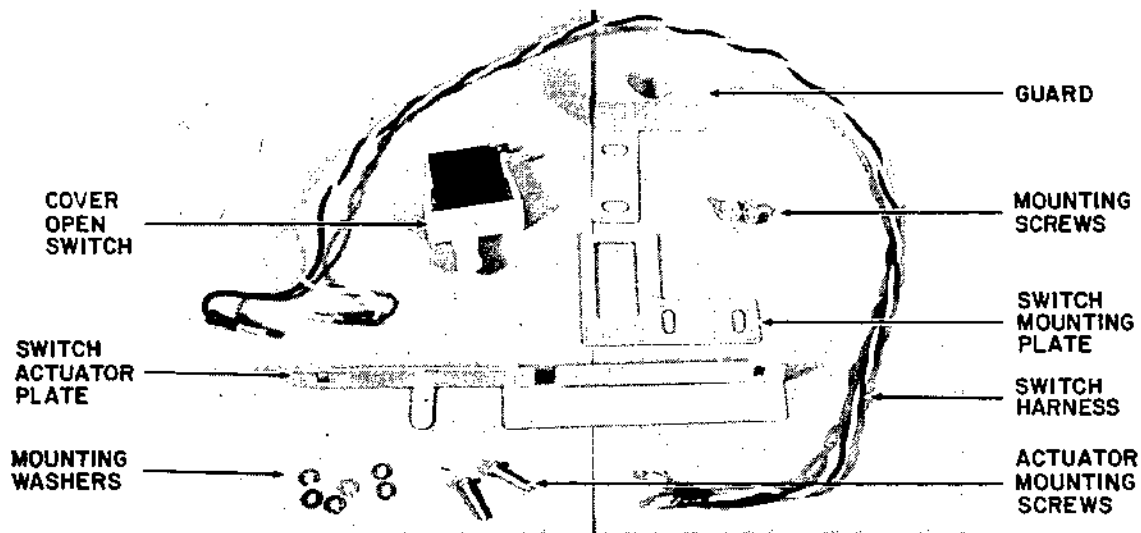

Figure 5-49 COVER OPEN SWITCH ASSEMBLY PARTS

5.4.9.1 Front Mounted Switch Installation Procedures

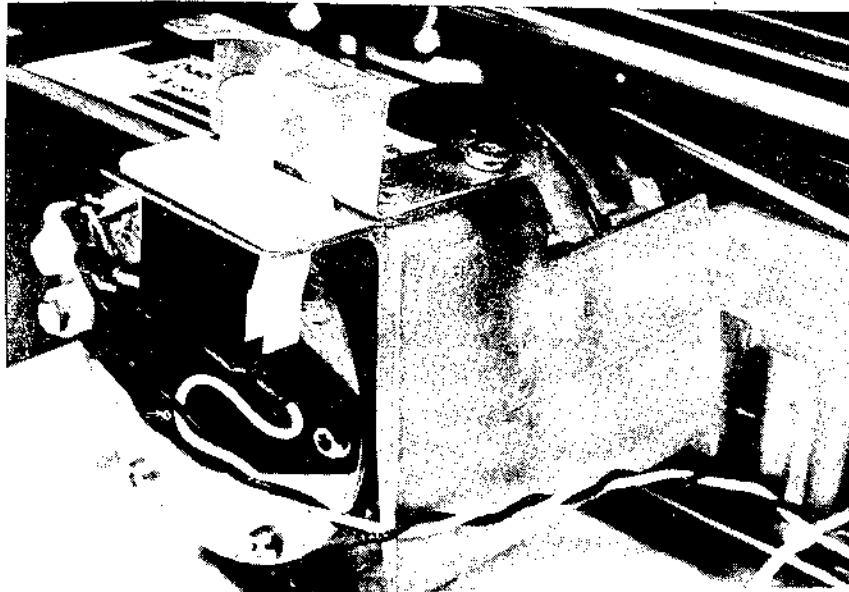

Figure 5-50 FRONT COVER OPEN SWITCH INSTALLATION

1. Study Figure 5-50. Install the switch in the switch plate, and attach the wire harness - black wire to the common terminal, white wire to the NO terminal.
2. Assemble the switch, plate and switch guard on the printer's main frame casting above the carriage servo motor as shown. Drive in the two 8-32 x 3/8" thread forming screws, but do not tighten them down.

3. Direct the wire harness down alongside the main frame to the bottom plate, and tie it alongside the carriage servo motor wires to the right, and back to the Motherboard. Connect the wires to Motherboard Terminals T1 and T2.

5.4.9.2 Front Mounted Switch Actuator Installation Procedure

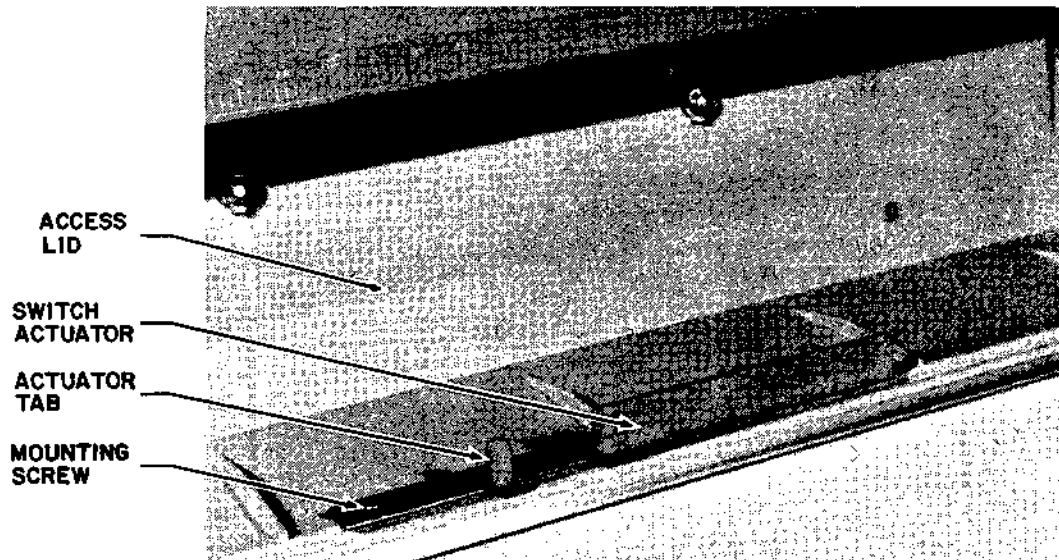

Figure 5-51 FRONT COVER OPEN SWITCH ACTUATOR INSTALLATION

1. Study Figure 5-51. Remove the two center 2-56 x 3/8" screws holding the Access Lid Handle to the Access Lid.

2. Orient the switch actuator over the vacated screw holes, place three #2 flat washers under the actuator at each hole location, and thread in two 2-56 x 1/2" screws. Tighten the screws firmly.

5.4.9.3 Front Mounted Switch and Actuator Adjustment Procedures

1. Lower the access lid. Adjust the switch laterally so that the actuator's tab strikes the switch plunger squarely. Open the lid and tighten the switch mounting screws firmly.

2. The cover open switch must switch over (close) at or before the point where the access lid snaps free from any one of its spring retainer clips, and must switch back (open) before the access lid is fully seated in its closed position. Also, the actuator must not drive the switch plunger all the way into the switch body. Adjust the actuator up or down as necessary to achieve these goals, and tighten the two mounting screws down firmly.

5.4.9.4 Side Mount Switch Adjustment Procedures

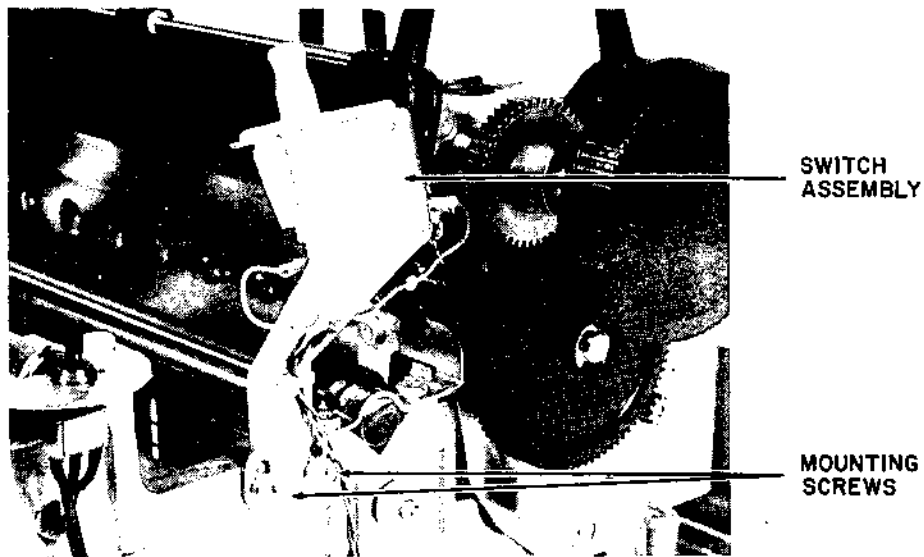

Figure 5-52 SIDE COVER OPEN SWITCH INSTALLATION

1. Study Figure 5-52. The side mounted switch assembly is held to the right side of the printer's main frame by two 8-32 x 3/8" screws. The switch plate mounting holes are slotted to allow both vertical and side to side adjustment of the switch location.

2. In this installation the switch plunger is actuated by contact with the access lid itself. The switch must be adjusted to switch over (close) at or before the point where the access lid snaps free from any one of its spring retainer clips, and must switch back (open) before the access lid is fully seated in its closed position. Loosen the mounting screws, and adjust the switch location to achieve these goals. Tighten the screws down firmly.

5.4.10 Adapter Cable Option Installation

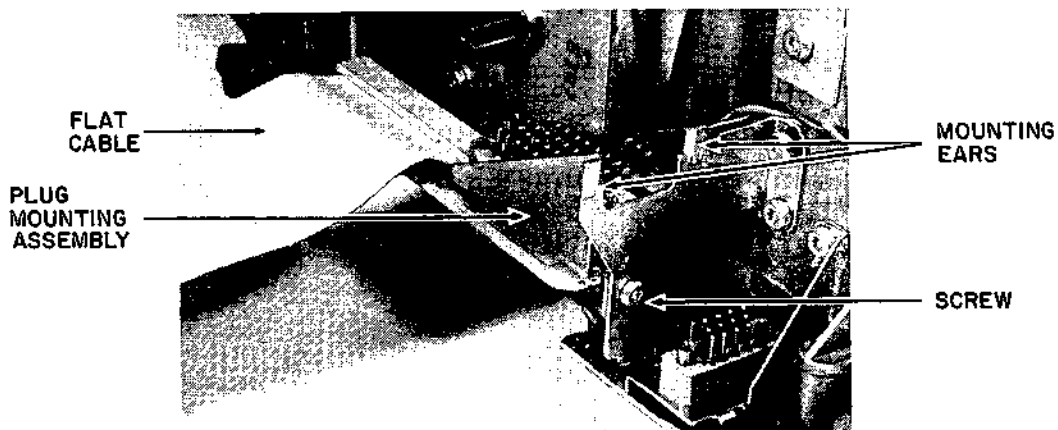

Figure 5-53 ADAPTER CABLE OPTION INSTALLATION

Refer to Figure 5-53.

1. Pinch the top ears of the cable's plug mounting assembly together slightly, and seat the assembly on the adapter bracket, which is a part of the mounting for the Motherboard. Drive in a 6-32 x 3/8" thread forming screw as shown to hold the assembly in place.

2. Fold the flat cable back under the printer, and direct its free end up into the printer's electronics compartment through the hole in the Motherboard and in front of the Logic I PCB. Plug the cable's 50-pin connector into the I/O socket near the top edge of Logic I PCB. In making this connection, be sure the triangular orientation mark on the plug is aligned with a similar marking on the PCB socket.

5.4.11 Split Platen Option - Installation and Adjustment

This option involves the installation of paper feed drive components and assemblies on the left end of the printer which are essentially identical to those installed on the right end of the printer. Refer to HyType II Parts Catalog No. 82404-XX for appropriate part numbers for the needed parts. Refer then to subsection 5.4.3 of this manual for installation and adjustment procedures. The components and assemblies are directly applicable for installation on either side of the printer.

The electronic control for the optional split platen drive is found on a special PC board, #40617-02. The schematic diagram for this PCB is included in Section 7 of this manual. The PC board itself plugs into either Slot E or F in the electronics compartment, depending on the Motherboard installed.

NOTE: Installation of this option precludes installation of the optional Internal Power Supply.

5.4.12 End Of Ribbon Sensor Option - Installation

The following procedure outlines the steps to install the optional End Of Ribbon Sensor on the carriage assembly of a Series 1300 HyType II Printer. Refer to the HyType II Parts Catalog No. 82404-XX for appropriate part numbers for the needed parts as well as an exploded view of the installation.

1. The interconnecting wires for this sensor option are already installed on the printer as a part of the carriage assembly's normal wiring. These wires are made up in a branching wire bundle separately insulated, folded back and tied to the right hand carriage frame member with cable ties. Locate this bundle, cut the ties and unfold the bundle. Replace the farthest rear cable tie, leaving the wire bundle end free.

2. Prepare the wire leads from the sensor, and complete the connections, color to color, to the wires in the wire bundle. Insulate all connections with heat shrink tubing.

3. Mount the sensor clip on the ribbon base plate, as shown in the Parts Catalog, and slip the sensor into position in the clip, part number UP. Secure the cable as needed with cable ties.

5.4.13 Internal Power Supply Options

5.4.13.1 Installation of the #24250-XX Power Supply (Datapower)

NOTE: These procedures will require the use of a 1/8" drill bit and a drill motor in addition to the usual assortment of hand tools.

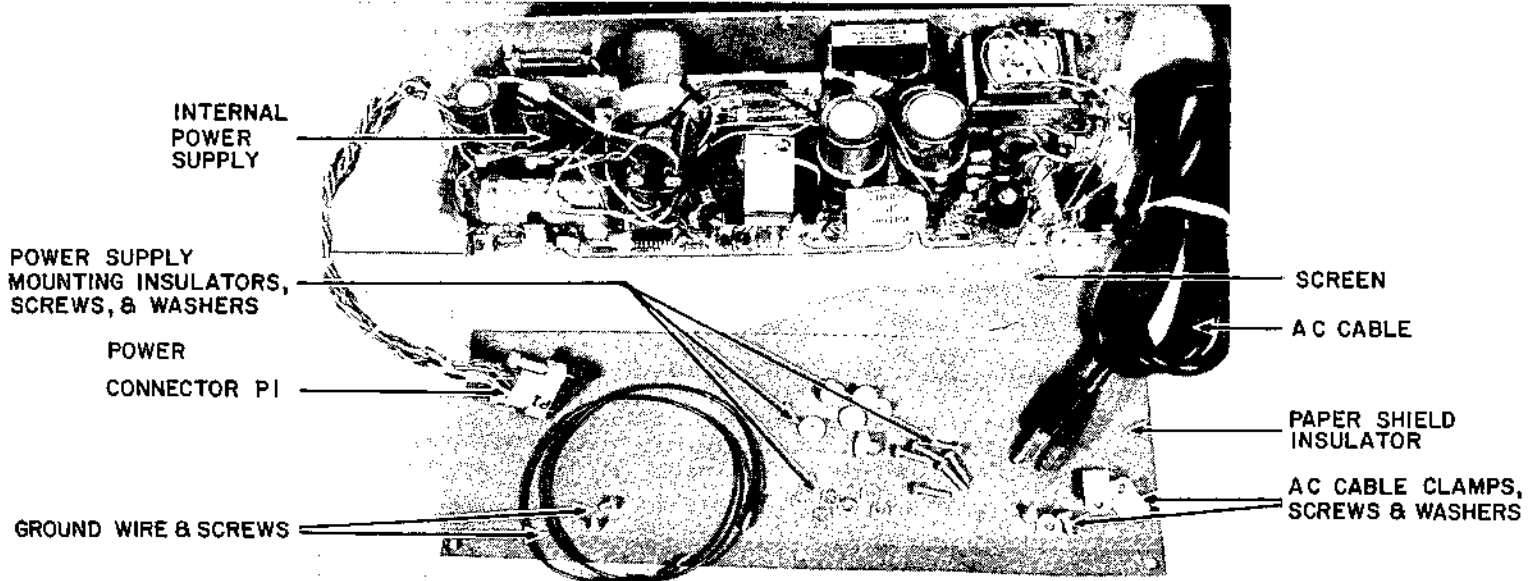

Figure 5-54 INTERNAL POWER SUPPLY #24250-XX INSTALLATION PARTS

1. Assemble and identify the various parts needed for installation of this option, as shown in Figure 5-54.
2. Remove the ribbon cartridge, print wheel, platen skirts (if installed), platen, paper cradle, covers (if installed), and all plug-gable circuit boards. If the center Cover Open Switch is installed dismount it and tie it back inside the main frame of the printer.
3. Stand the printer up on the front end of its main frame for access to the bottom.
4. Locate the cavity into which the power supply is to be fitted. On the lower right front corner (as you view it) of this cavity, locate a screw hole provided for mounting the Bottom Feed Paper Chute. This hole is opposite the similar left-hand location used as a grounding point. Beside this screw hole is a smaller hole used for locating a carrier hold-down spring. Between this latter hole and the side member of the frame, drill two (2) 1/8" holes approximately 1/4" apart, as shown in Figure 5-55. These holes will be used as new grounding points for this installation. Be careful not to allow the drill shavings to get into the printer's mechanisms.

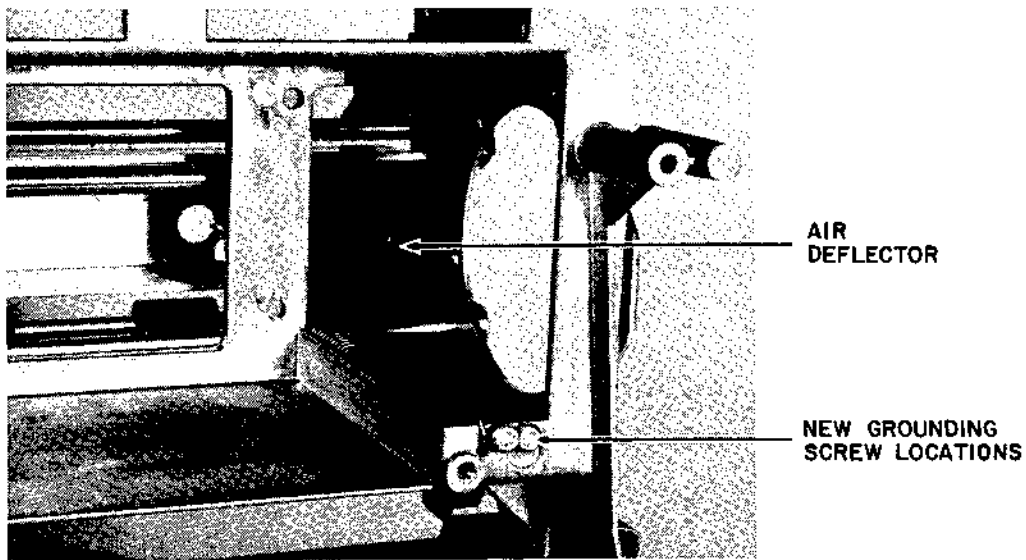

Figure 5-55 FAN AIR DEFLECTOR INSTALLATION

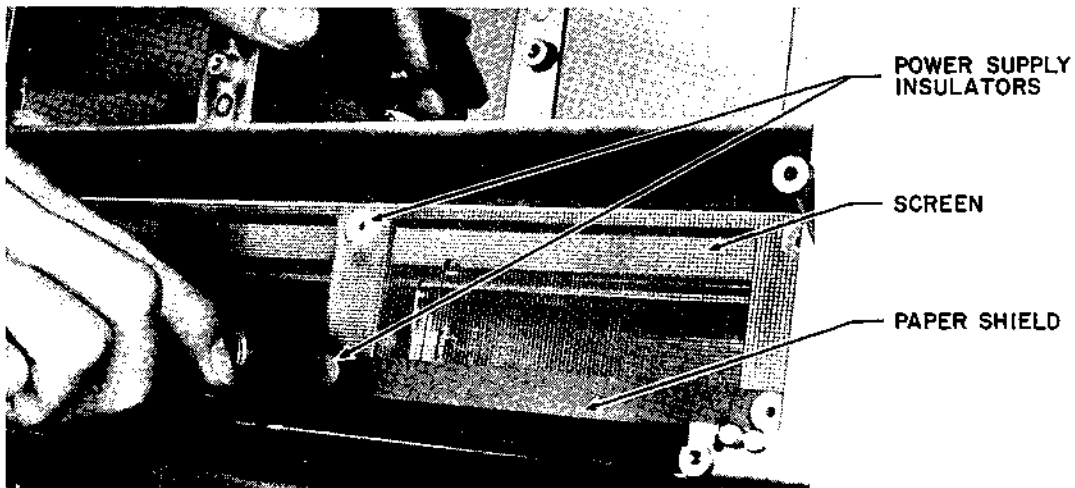

Figure 5-56 SCREEN AND SHIELD INSTALLATION

5. Study Figure 5-55. Locate and install the heavy paper air deflector, a part of the cooling fan installation, if the fan is to be used.
6. Study Figure 5-56. Locate and install the screen, paper shield insulator, and six (6) power supply insulators as follows (all directions of up, down, right or left, etc. are as you view it):
 - (a). Remove the screws holding the Motherboard in place, and drop the assembly down out of the way. Cut any cable ties which impede this step.
 - (b). Install the screen, notches down, by placing the screen in position, and inserting three of the power supply insulators through the upper three holes in the screen and into three holes spaced along the top of the cavity at the top ends of three main frame cross members.

NOTE: Insertion of the power supply insulators is made easy by use of a tool, such as a #99-24 Xcelite hex driver and handle. The tool end is inserted through the insulator which can then be easily pushed into the main frame casting hole with hand pressure. An occasional light tap on the tool handle may be needed to completely seat the insulator(s).

(c). Bend the paper shield insulator where scored, and install it along the bottom of the cavity using the remaining three power supply insulators, inserted as above. Figure 5-56 shows the center of these three insulators being installed.

7. Slide the power supply into place in the cavity, circuit board down and interconnecting power cable to the left. Fasten the supply into place by driving the six (6) 6-32 x 5/8" screws in through the #6 flat washers, the power supply insulators and into threaded holes in the power supply frame. Tighten these screws down to deform the tips of the insulators and spread them out under the washers. Be careful not to overtighten these screws which will cause the insulators to break up.

8. Form the supply's dc power cable to the left out of the cavity, and reinstall the Motherboard.

9. Remove and discard the short black jumper wire installed between the Motherboard Terminal T3 and the left-hand frame grounding point, and replace the grounding screw to retain the ground wire coming from the carriage.

10. Connect the spade lug end of the long black replacement ground wire to Motherboard Terminal T3. Route this wire to the right alongside the established wire bundles, and secure it with cable ties.

11. Connect the ring lug end of the new ground wire, along with the green ground wire from the right end of the power supply, to the printer's main frame at the farthest right of the two screw holes drilled in Step 4 above, using a 6-32 x 3/8 thread forming screw.

12. Study Figure 5-57. Install and connect the ac power cable as follows:

- (a). Connect the ac cable's white wire to power supply barrier strip terminal 2. This is the inside terminal of the strip located on the right-hand end of the supply.
- (b). Connect the ac cable's black wire to power supply barrier strip terminal 1. This is the outside terminal.
- (c). Connect the ac cable's green wire to the printer's main frame at the farthest left of the two holes drilled in Step 4, using a 6-32 x 3/8 thread forming screw.
- (d). Arrange the ac cable out and across the left rear side of the printer's main frame.

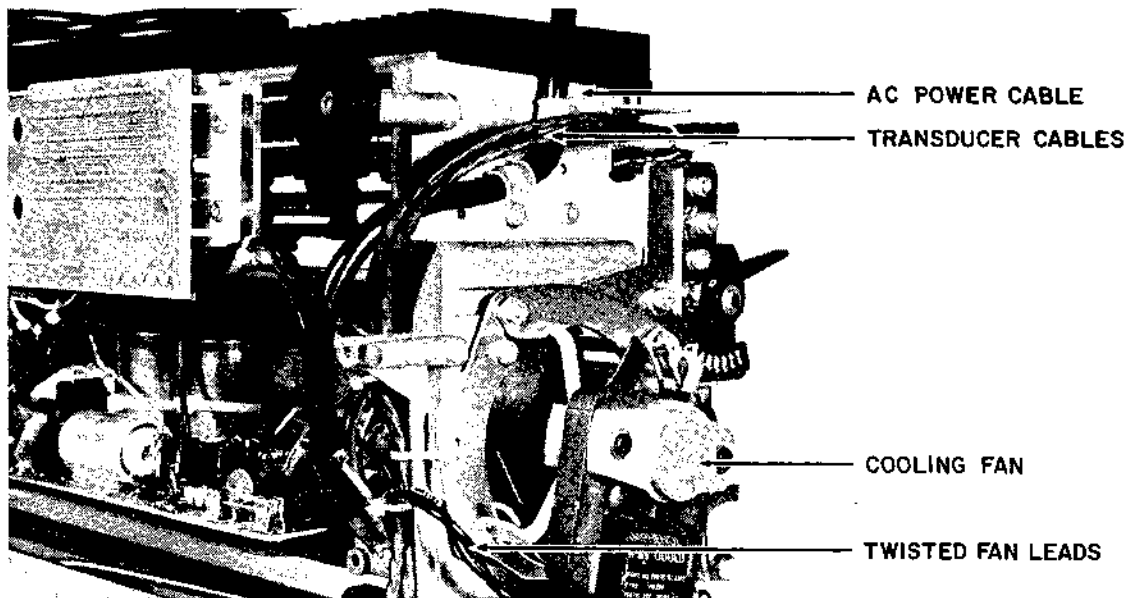

Figure 5-57 AC CABLE AND FAN INSTALLATION

NOTE: The ac cable MUST cross the two transducer cables at right angles as nearly as possible. Use cable ties as required to secure the crossing points of these cables at right angles.

13. Return the printer to its upright position. At its right-hand end, arrange the extended dc power cable toward the rear up and over the adapter cable bracket and connect its plug to the power connector on the end of the Motherboard.

14. At the left-hand end of the printer, arrange the ac power cable up across the side of the main frame toward the rear as required by the intended installation. Secure the cable in place with the cable clamp(s), 'D' washer(s), and 8-32 x 3/8" thread forming screw(s).

5.4.13.2 Installation of the 26021-XX Power Supply (Boschert)

1. Assemble and identify the various parts needed for installation of this option, as shown in Figure 5-58.

2. Remove the ribbon cartridge, print wheel, platen skirts (if installed), platen, paper cradle, and covers (if installed). If the center Cover Open Switch is installed, dismount it and tie it back inside the main frame of the printer.

3. Stand the printer up on the front end of its main frame for access to the bottom.

4. Study Figure 5-55. Locate and install the heavy paper air deflector, a part of the cooling fan installation, if the fan is to be used.

5. Connect the dc power cable to the power supply's terminal block as shown in Figure 5-59. If the ac and fan motor power cables are to be installed also they should be connected at this time.

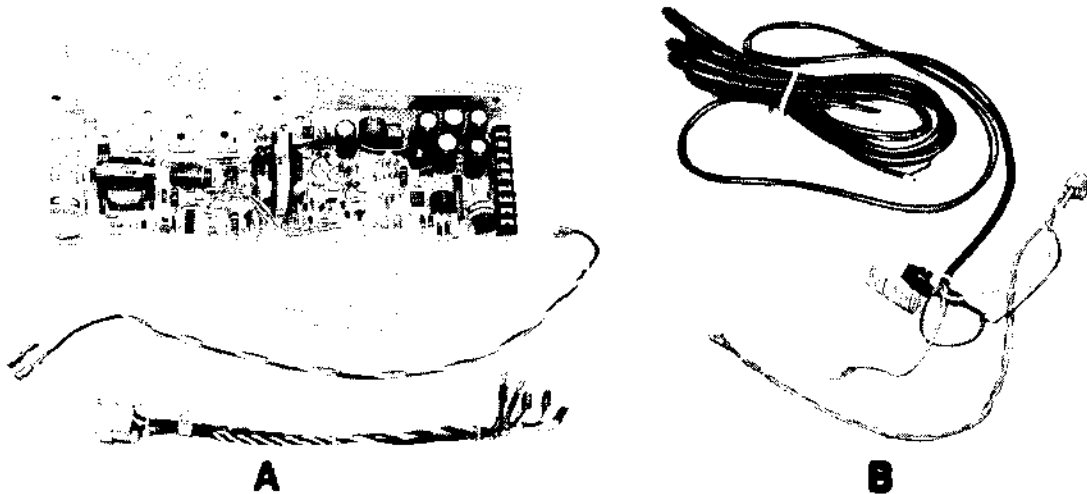

Figure 5-58 INTERNAL POWER SUPPLY #26021-XX INSTALLATION PARTS

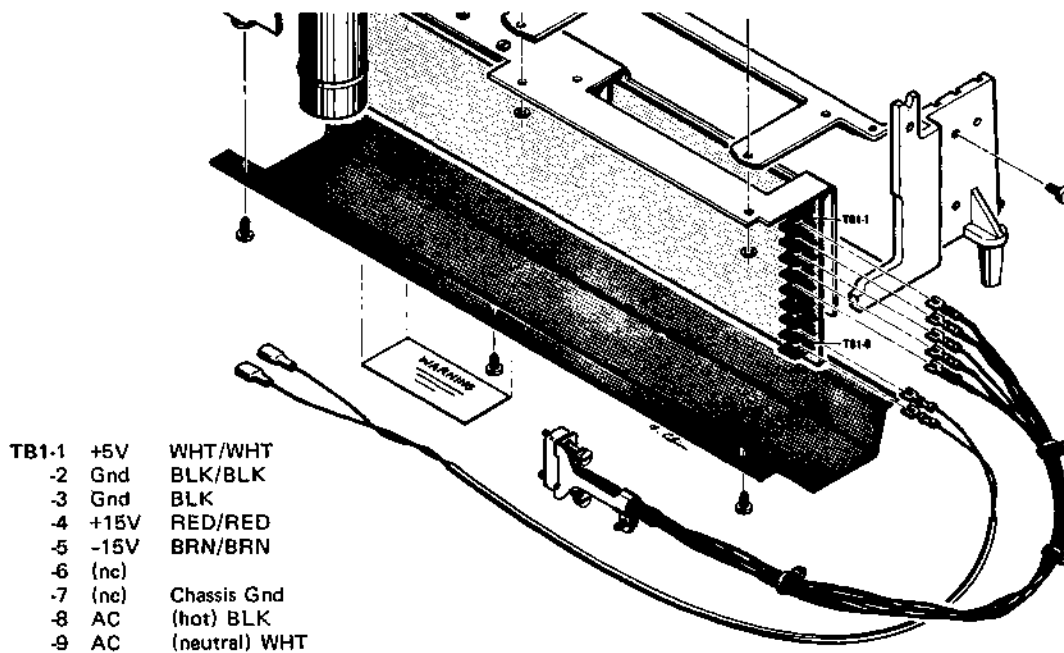

Figure 5-59 AC AND DC POWER CONNECTIONS

6. Slide the metal screen into position on top of the main frame under the paper carrier assembly, and align its screw holes with holes in the top surface of the main frame.

7. Carefully work the power supply into position within the main frame cavity with its interconnecting cables to the left, and fasten it into place by driving four (4) 6-32 x .500" screws in through the screen, the main frame, and into threaded holes in the frame of the power supply.
8. If the fan motor power cable is connected, work it in between the power supply and the main frame and out to the right.
9. Form the dc power cable to the left, along with the ac power cable if installed, and return the printer to its upright position.

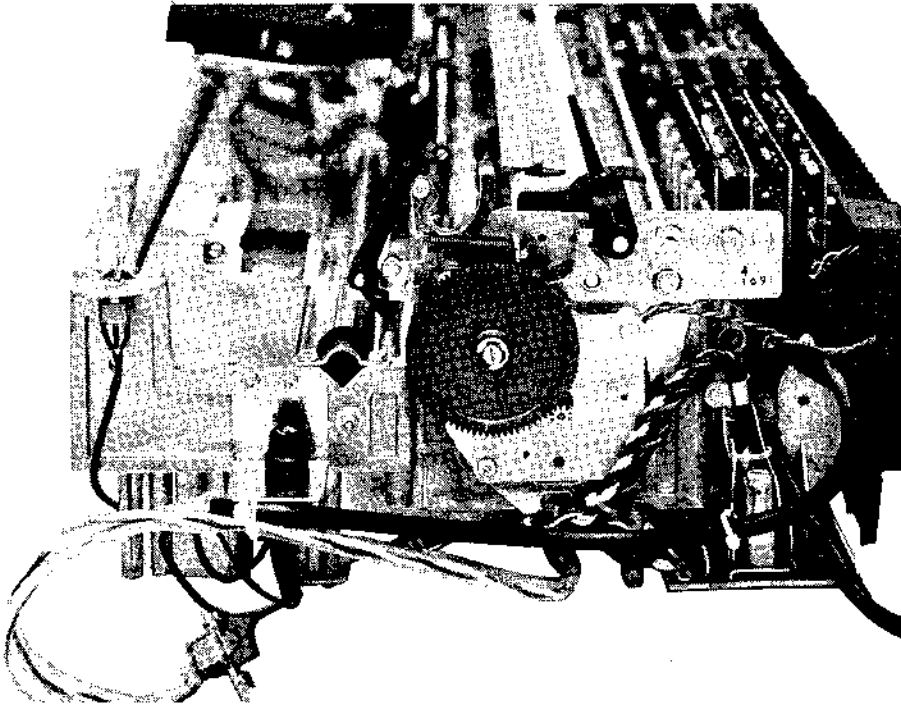

Figure 5-60 AC AND DC CABLE INSTALLATION

10. At the left-hand end of the printer, arrange the extended dc power cable toward the rear up and over the adapter cable bracket and connect its plug to the power connector on the end of the Motherboard, as shown in Figure 5-60.
11. If the ac power cable harness assembly, Diablo No. 23899, is being installed, refer to Figure 5-60. Mount the fuse holder bracket on the left front side of the printers main frame using 8-32 x .375" thread forming screws.
12. Stand the printer back on the end of its main frame. Locate a hole in the main frame casting on the inside of the frame near the bracket just installed. Attach the green wire from the power cord to the main frame at this point using an 8-32 x .375" thread forming screw. Return the printer to its upright position.

13. Refer again to Figure 5-60. Arrange the ac power cord back along the right side of the printer frame as shown, and secure with a plastic cable clamp, "D" washer, and an 8-32 x .500" thread forming screw.

5.4.13.3 Installation of the #301155-XX Diablo Universal Internal Power Supply

(information not available at time of printing)

5.4.13.4 Installation of the #40809-XX Cooling Fan



Figure 5-61 COOLING FAN INSTALLATION PARTS

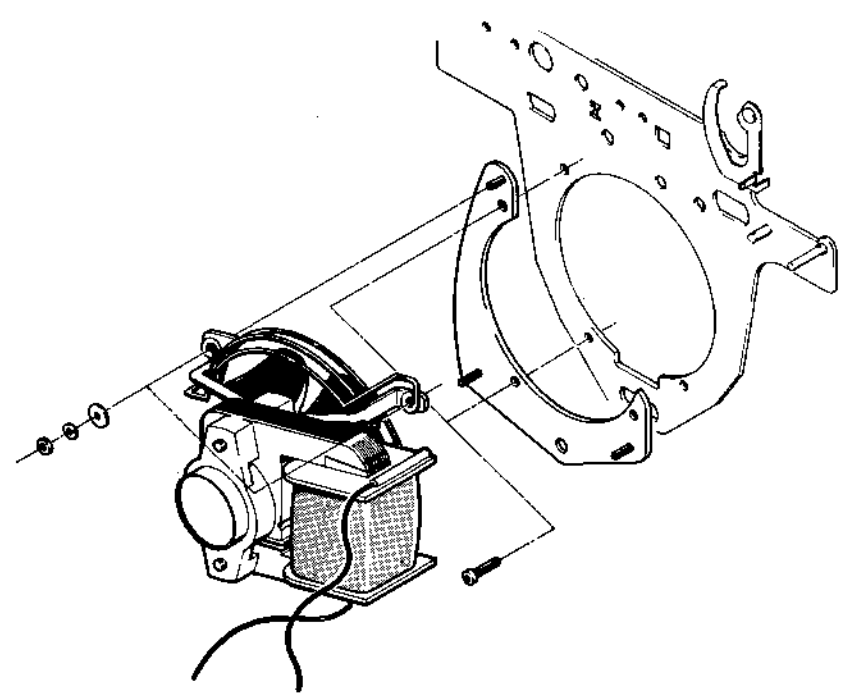

Figure 5-62 COOLING FAN ASSEMBLY INSTALLATION

1. Assemble and identify the various parts needed for installation of the cooling fan, as shown in Figure 5-61.
2. Refer to Figure 5-62. Install the mounting plate on the left-hand carrier side plate as shown, using three (3) 8-32 x .250" thread forming screws.
3. Mount the fan motor on the plate as shown, using a #6 flat washer, #6 lock washer, and a 6-32 hex nut on each of the three studs. Note that the fourth "leg" of the fan motor is not used, but has the fan guard fastened to it with an eyelet.
4. If this installation is mated to a #24250-XX Power Supply, the fan motor configuration should be 40809-01 or -02. This configuration has ring terminals on its wire ends for connection to the ac terminals on the power supply. These two connections, when completed, place the fan in parallel with the ac input. Arrange the leads to cross the two twisted-pair transducer cables at a right angle, and secure this crossing point with a cable tie to ensure that the right angle will be maintained.
5. If this installation is mated to a #26021-XX Power Supply, the fan motor configuration should be 40809-03 or -04. This configuration has slip-on quick disconnect terminals on its wire ends for connection to the mating terminal ends on the fan motor ac power cable. After completing the connections, arrange the leads to cross the two twisted-pair transducer cables at a right angle, and secure this crossing point with a cable tie to ensure that the right angle will be maintained.

CAUTION: Make sure the fan motor's power requirements match the power source to be used.

SECTION 6

APPENDICES

6.1 GENERAL INFORMATION

This section describes the three standard model HyType II Printers. It also lists and describes the several accessories and optional features presently available for each model.

6.2 THE STANDARD HYTYPE II PRINTER

The standard Model 1345A and 1355HS HyType II Printers are shipped complete including a COURIER 72 10-pitch 96 character plastic print wheel and a 1-color (black) cloth ribbon cartridge.

The standard Model 1355WP HyType II Printer is shipped complete including a TITAN 10 10-pitch 88 character metalized word processor print wheel and a black multistrike film ribbon cartridge.

Covers, platens and any other of the available accessories and options may be ordered separately for ease in matching the machine to the users application.

6.3 SUPPLIES

Refer to Diablo Publication No. 90007-XX Printer Supplies Catalog for a complete listing of all currently available print wheels and ribbon cartridges for HyType II Printers.

6.4 ACCESSORIES

6.4.1 Cover Sets

The standard Diablo Printer Cover Sets are applicable to all models of the Series 1300 HyType II Printer. They include:

- * Receive Only (R/O)
 - Tabletop
 - Regular Platen or Forms Feed
 - Regular or Bottom Paper Feed
- * Keyboard-Send-Receive (K/S/R)
 - Tabletop or Flush Mount
 - Regular Platen or Forms Feed
 - Regular or Bottom Paper Feed

Refer to Diablo Publication No. 82404-XX Series 1300 HyType II Printer Parts Catalog for a complete listing of all currently available Diablo Cover Sets.

6.4.2 Paper Handling Accessories

6.4.2.1 Platens

1. Friction Feed Platen This platen is very similar to the rubber surfaced platens found in regular typewriters.

2. Unidirectional Pin Feed Platen This platen features a set of cam operated paper feed pins on each end of the roller. This rubber surfaced platen is available in several lengths.

3. Bidirectional Pin Feed Platen This platen features a set of dual cam operated paper feed pins on each end of the roller. The dual cam feature allows paper to be moved backward (down) as well as forward (up) without jamming. This platen is available in two lengths for either 14.875" (377.83 mm) or 15.000" (381 mm) paper.

Refer to Diablo Publication No. 82404-XX Series 1300 HyType II Parts Catalog for a complete listing of the several styles of platens.

6.4.2.2 Forms Tractors

1. Unidirectional Forms Tractor This unit mounts on top of the printer cover where it engages the platen shaft for alignment and drive. It requires use of a friction feed platen. It is adjustable to any paper width from 1-1/2" (38.1 mm) to 14-1/2" (368.3 mm) maximum as measured between the pin feed drive holes.

2. Bidirectional Forms Tractor This unit mounts on top of the printer cover where it engages the platen shaft for alignment and drive. It requires use of a friction feed platen. It is adjustable to any paper width from 1-1/2" (38.1 mm) to 14-1/2" (368.3mm) maximum as measured between the pin feed drive holes. It also features both upper and lower pin feed drives to enable feeding paper in either direction.

NOTE: Installation of the optional Forms Tractor Sound Cover will reduce maximum allowable paper width by 1/2" (12.7 mm) when used with the "thumb screw" version of the Forms Tractor.

6.4.2.3 Bottom Feed

All models of the Series 1300 HyType II Printer can be configured to allow feeding of continuous (manifold) forms up thru the bottom of the mechanism. This optional feature requires use of a pin feed platen or a Forms Tractor, and enables placing paper stocks underneath the machine for easier resupply. It also facilitates the handling of heavy or stiff papers which could not otherwise be accommodated. This option includes a Paper Out switch. Users should also note that the bottom feed paper chute requires operating the machine with the paper release lever fully forward.

6.4.2.4 Sheet Feeders

1. Mechanical Front Feed Refer to Figure 2-5, and to Diablo Publication No. 90421-XX Mechanical Front Feed Operation and Maintenance. This unit mounts on top of the printer cover. It engages the platen shaft for alignment and drive. This unit requires use of a friction feed platen. It feeds multipart forms, and single sheets up to 48 lb ledger stock into the printer, one at a time. The inserted item extends down into a special bottom chute and out under the printer to allow printing within 1" of the top and at the very bottom before being ejected out the top. This accessory preempts use of the bottom feed option.

2. Auto Front Feed Refer to Figure 2-4, and to Diablo Publication No. 90422-XX Auto Front Feed Operation and Maintenance. This accessory consists of the Auto Front Feed unit, a special bidirectional forms tractor, interconnecting wiring, and a special Option PCB. A Diablo Cover Set (or equivalent) and a friction feed platen are required, and Option Slot E or F must be open to receive the special PCB. The resulting system feeds multipart forms, and single sheet paper up to 48 lb ledger stock in much the same manner as the Mechanical Front Feeder described above.

This unit operates independently of the printer's paper drive system. It can be used in conjunction with continuous form (manifold) paper, with both auto feed and form feed controlled separately by the host system. An optional optical line finder version allows the feeder to find the last line printed and position itself to print the next line automatically.

3. HyFeed Sheet Feeder Refer to Figure 2-6, and to Diablo Publication No. 90420-XX HyFeed Sheet Feeder Operation and Maintenance. This unit mounts on top of the printer cover and engages the platen shaft for alignment and drive. It draws power either from the printer or from an optional external power supply. The Feeder permits storing, automatic feeding, and retaining of up to 200 sheets of 20 lb paper. Printing is possible from the extreme top to the extreme bottom of the page, or automatic positioning to a "top margin" starting point. This unit requires the use of the friction feed platen and the HyFeed Interface Kit.

6.5 OPTIONS

6.5.1 Jumper Wire Operating Mode Options

Each Logic 1 Interface PCB includes three jumper wire locations. These are labeled RIB. OPT 1, RIB. OPT 2, and HAMMER ENERGY. These represent optional operating modes, selectable by soldering in a jumper wire in the appropriate location. Section 3 of this manual contains detailed information on each of these jumpers as it concerns each printer model.

6.5.2 Split Platen Drive

The HyType II design provides OPTION READY and OPTION STROBE lines at the interface which enable implementation of selected options or special features. One such implementation, applicable to Models 1345A and 1355HS only, is the Split Platen Drive Option. This option includes an additional plug-in circuit board, and a paper feed drive motor assembly to provide a separate paper feed drive for the left-hand side of a split platen installation. Left paper feed data is transmitted to the printer along with the OPTION STROBE signal and in conjunction with the Option Status signals. Paper Feed Ready and Option Ready status signals must be present prior to sending the Paper Feed Strobe (to drive the right-hand motor) or Option Strobe (to drive the left-hand motor). Both paper feed motors CANNOT be active at the same time. This option cannot be used in machines which have the optional Internal Power Supply installed. See subsection 4.10 for a discussion of the principles of operation for this circuit.

6.5.3 HyType I Adapter Cable

An optional Adapter Cable, Diablo No. 40508-XX, is available for those users who must maintain a HyType I plug-for-plug compatibility. See subsection 2.2.3.

6.5.4 Paper Out Circuit and Switches

6.5.4.1 Paper Out Circuit

The HyType II design includes a paper out circuit which may be used to process signals from optional paper out switch or sensor installations. This circuit provides an active LO signal to the interface whenever its input is LO (or grounded). If unused, the output signal line will always be LO. Implementation of this option mandates use of a 50-wire interface cable in lieu of the optional No. 40508-XX Adapter Cable. Users should note that the circuit is a switch only, and will require a software debounce of 20 msec minimum before allowing the controller to recognize the change of state.

6.5.4.2 Bottom Feed Paper Out Switch

As noted earlier, the optional Bottom Feed installation includes a paper out switch which is deactivated as long as paper is present in the bottom feed paper chute.

6.5.4.3 Top Feed Paper Out Switch

An optional Top Feed Paper Out switch assembly is available for use with HyType II Printers. Users should note that use of this option requires operating the printer with the paper release lever fully forward, and the use of either a pin feed platen or a forms tractor.

6.5.5 End Of Ribbon Circuit and Sensor

6.5.5.1 End Of Ribbon Circuit

The HyType II design includes an end of ribbon circuit which may be used to process a signal from an optional end of ribbon sensor. This circuit provides an active LO signal to the interface whenever the optional end of ribbon sensor detects the end of a multistrike ribbon. Implementation of this option mandates use of a 50-wire interface cable in lieu of the optional No. 40508-XX Adapter cable.

6.5.5.2 End Of Ribbon Sensor

An optional end of ribbon sensor is available for use with HyType II Printers. The sensor mounts on the right rear corner of the ribbon platform on the carriage, and connects to existing wires in the print wheel motor-transducer-ribbon lift cable. The sensor consists of a light source and an optically sensitive detector. The multistrike ribbon includes a section of reflective tape near its end. As the ribbon supply is fed from the supply reel to the take-up reel within the cartridge, the reflector appears in a window when the cartridge is nearly used up. This reflector returns the light source to the detector to initiate the end of ribbon signal.

6.5.6 Cover Open Circuit and Switch

6.5.6.1 Cover Open Circuit

The HyType II Printer design includes a cover open circuit which may be used to process signals from an optional cover open switch installation. This circuit provides an active LO signal to the interface whenever its input is LO (or grounded). Implementation of this option mandates use of a 50-wire interface cable in lieu of the optional No. 40508-XX Adapter Cable. Users should note that the circuit is a switch only, and will require a software debounce of 20 msec minimum before the controller is allowed to recognize a change of state.

6.5.6.2 Cover Open Switch

An optional cover open switch assembly is available for use with HyType II Printers. It mounts on the front of the printer's main frame where it is actuated by the top access cover.

6.5.7 Internal Power Supplies

Several optional power supplies are available for use in HyType II Printers. They mount inside the printer's main frame, and usually include a cooling fan which mounts on the left side of the main frame. None of these supplies are switched, as mentioned earlier, and they must be controlled by the host system. Users should note that installation of this option precludes installation of the split platen drive option as it applies to Models 1345A and 1355HS. Users should also note that the supply's cooling fan is connected across the ac supply line. The supplies are strappable for either 115 or 230 Vac sources, and care should be taken to ensure the fan's power requirements match the intended supply level. Refer to subsection 4.9 for a discussion of the principles of operation of the Internal Power Supplies.



SECTION 7

LOGIC DIAGRAMS AND LOGIC SYMBOL CONVENTIONS

7.1 GENERAL DISCUSSION

Diablo Systems logic diagrams emphasize the functions performed by the logic elements rather than the kinds of devices used. For example, a NAND gate may appear on a Diablo diagram as either a positive logic AND function with the output inverted (NAND), or as a negative logic OR function with the inputs inverted (NOR). This practice runs contrary to some logic drawing standards which require the use of the NAND symbol for both functions, but aids field service personnel in troubleshooting and system design engineers in understanding the principles of operation of the design.

This functional approach to logic symbology is basic to the logic documentation conventions employed by Diablo Systems. The conventions that govern logic symbology, signal nomenclature, and other drawing standards that may help the reader interpret Diablo logic diagrams, are discussed in the following paragraphs.

7.2 LOGIC SYMBOLOGY

The logic function symbols used in Diablo Systems logic diagrams conform closely to those set forth in MIL-STD-806 or ANSI Y32.14-1973. Small scale integration (SSI) circuits are represented by their function symbol. Medium scale (MSI) and large scale (LSI) integration devices, such as shift registers, RAM's, ROM's, etc., are represented by rectangles with function labels. Since both positive and negative logic conventions can appear in a single diagram, the unfilled circle negation symbol specified by MIL-STD-806 or ANSI Y32.14-1973 is used to distinguish between LO true and HI true signals.

Usually, all logic symbols are drawn with inputs on the left and outputs on the right. Some device symbols, such as flip flops, show inputs and other external connections on the top and bottom of the symbol for clarity. Also, the drawings themselves are usually drawn with major signal flows from left to right, top to bottom. However drawing layout restrictions occasionally require the reverse of this, and that some symbols be drawn with a vertical orientation.

Figure 7-0 is a sample diagram, drawn to include examples of most if not all of the drawing conventions used. Note that in some cases two "grid coordinate" systems are used. One, shown on the perimeter of the diagram, is useful in locating a portion of a circuit or a particular component on the diagram itself, and has no other meaning. The other involves the component identifiers, such as "Resistor H35". The identifier is a "grid coordinate" code for locating that component on its printed circuit board. Further, textual reference to a device, such as a flip-flop, will usually further identify the device by its major output terminal. In the case of flip-flops, the "Q" output is usually used, i.e. FF B25-9.

7.3 LOGIC DEVICES

The following pages illustrate the make-up of the logic devices used in this machine, and include pertinent information such as truth tables, where possible.

7.4 SCHEMATIC DIAGRAMS

The schematic diagrams which follow the logic device illustrations represent the latest versions of the several PCB circuits in current production at the time of printing this manual. Listed on the back of each diagram will be found the revision history of that circuit plus a listing of the solid state components used in the circuit, along with the component designator codes used for locating each device on its PCB. The following table lists the applicability of each schematic.

Dwg No.	Description	1345A	1355HS	1355WP
40500-XX	Motherboard, Standard	X	X	X
40614-04	Motherboard, 8080	X		
46080-01	Motherboard, Systems	X		
40505-09	Logic 1, Standard ESD	X	X	X
40644-05	Logic 1, 8080 & Systems	X		
40725-05	Logic 1, Special D	X		
40510-XX	Logic 2, Standard	X	X	X
301850-XX	Logic 2, Standard ESD	X	X	X
40515-04	Transducer, Standard ESD	X	X	X
40520-04	Servo, Standard	X		X
46020-02	Servo, HS		X	
40525-10	Car P A, Standard	X		X
40525-11	Car P A, Standard ESD	X		X
46025-05	Car P A, HS		X	
46025-06	Car P A, HS ESD		X	
40530-10	P W P A, 1345 Standard	X		
40530-11	P W P A, 1345 Standard ESD	X		
40730-10	P W P A, 1355 Standard		X	X
40730-11	P W P A, 1355 Standard ESD		X	X
40617-02	Split Platen, Standard	X		

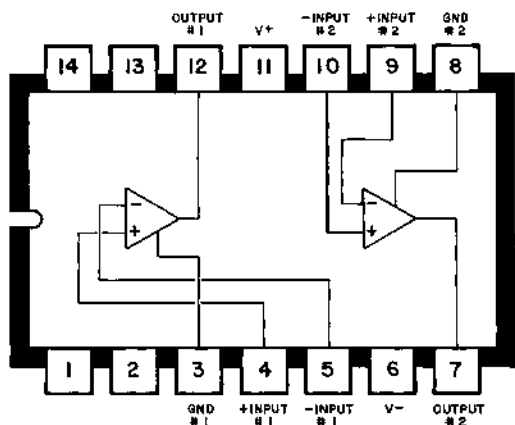

DUAL HIGH SPEED COMPARATORS
319 / LM - 319N

10168

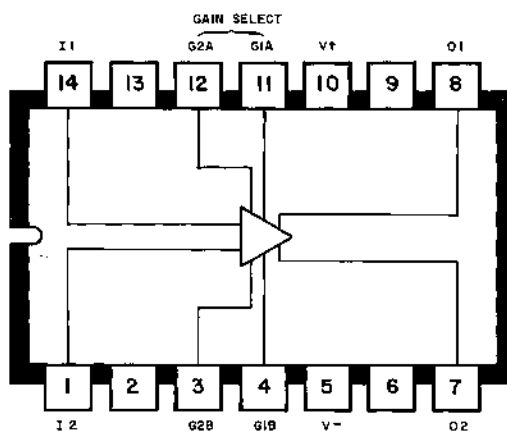

DIFFERENTIAL AMPLIFIER
733 / N5733C / LM733CN

10124

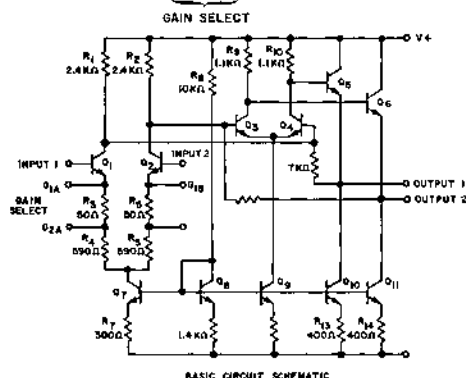

BASIC CIRCUIT SCHEMATIC

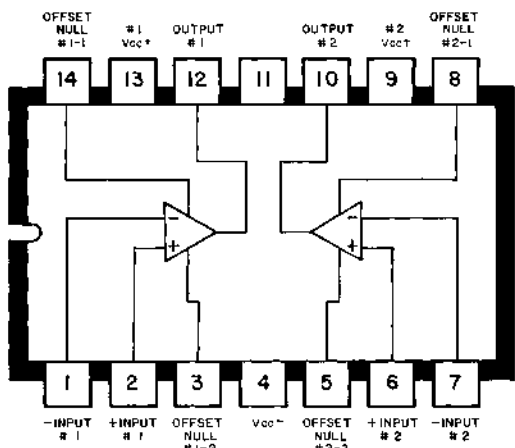

SCHEMATIC (each amplifier)

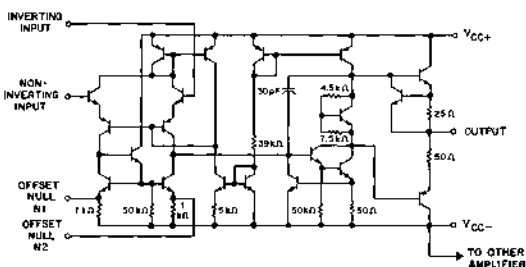

DUAL HIGH PERFORMANCE OP-AMPL.
747C / SN72747N

10165

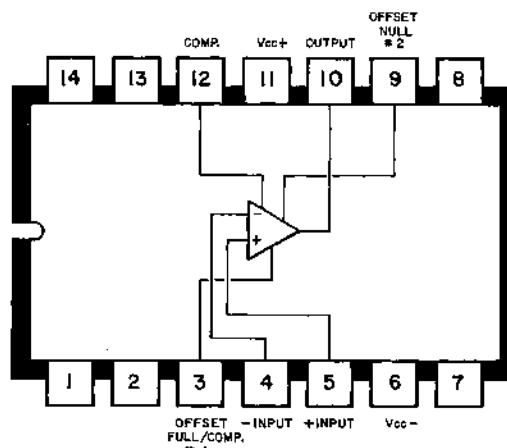

HIGH PERFORMANCE OP-AMPL.
748 / SN72748

10166

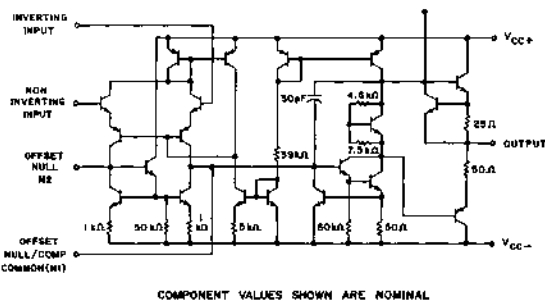

COMPONENT VALUES SHOWN ARE NOMINAL

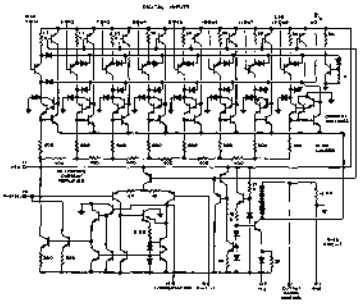
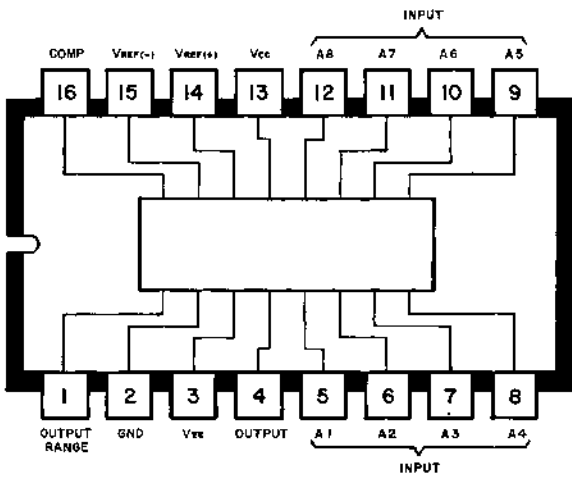

D-A CONVERTER
1408L-6 / MC1408L-6

13060

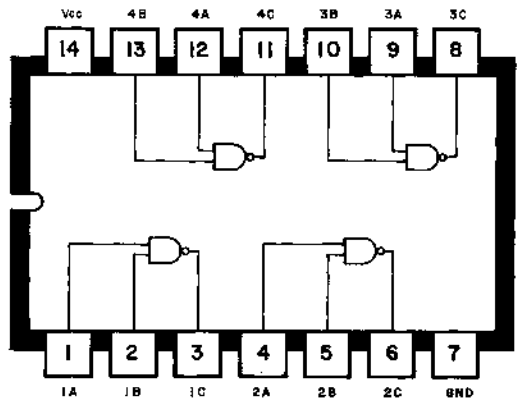

QUAD 2-INPUT NAND GATE
7400 / DM7400N / SN7400N

10134

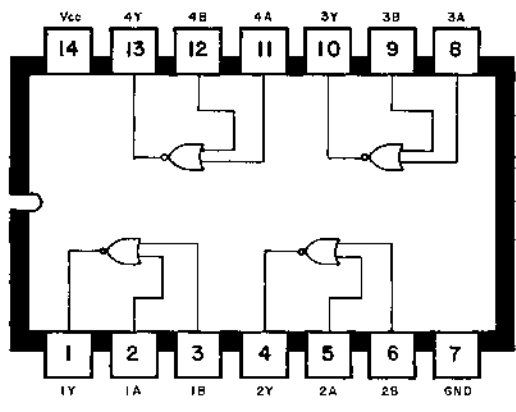

QUADRUPLE 2-INPUT POSITIVE NOR GATES
7402 / SN7402

10135

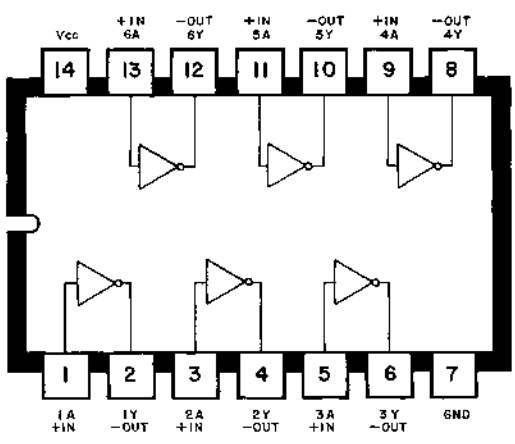
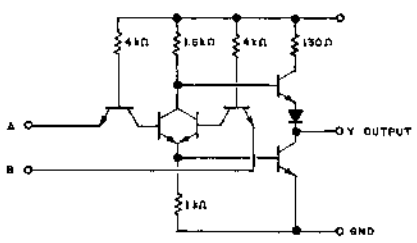

HEX INVERTER
7404 / DM7404N / SN7404N

10136

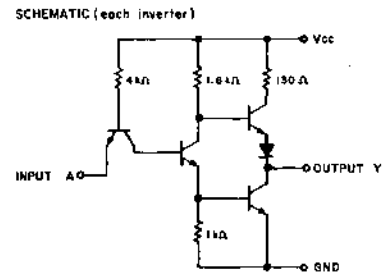

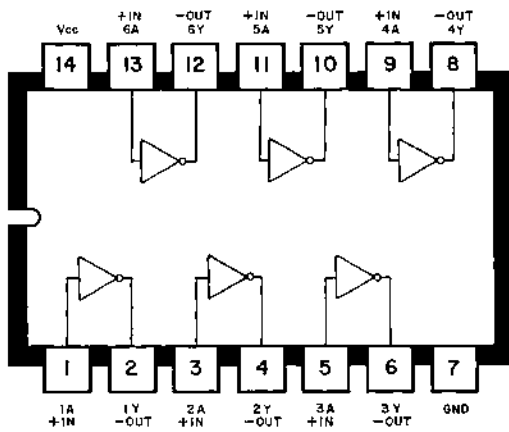

SCHMATIC (each inverter)

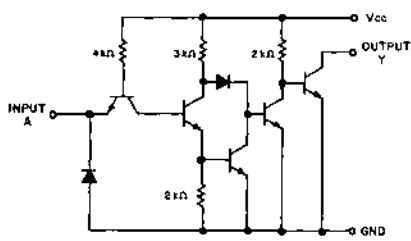

NOTE: Component values shown are nominal.

HEX INVERTER-OPEN COLLECTOR
7406 / SN7406N

10460

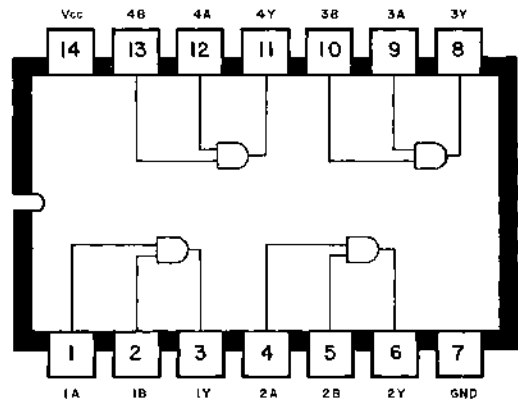

SCHMATIC (each gate)

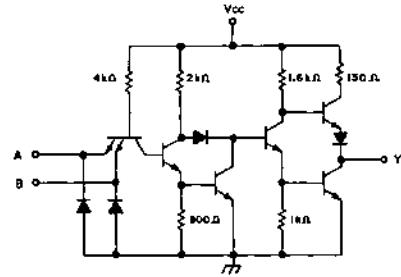

QUAD 2-INPUT AND GATE
7408 / DM7408N / SN7408N

10119

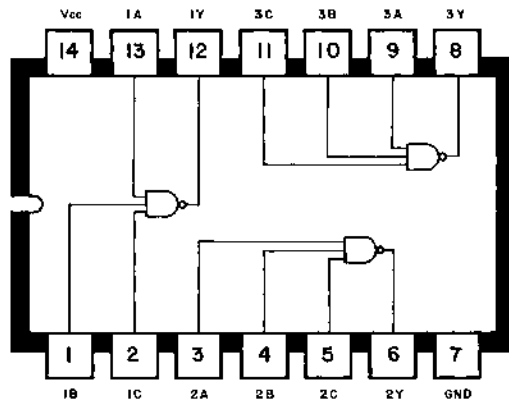

TRIPLE 3-INPUT NAND GATE
7410 / DM7410 / SN7410N

10133

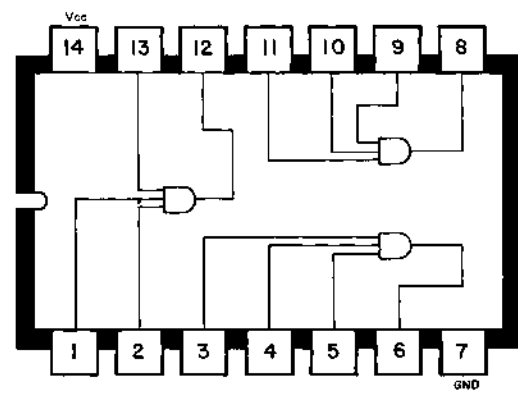

TRIPLE 3-INPUT POSITIVE AND GATE
7411 / N7411

10301

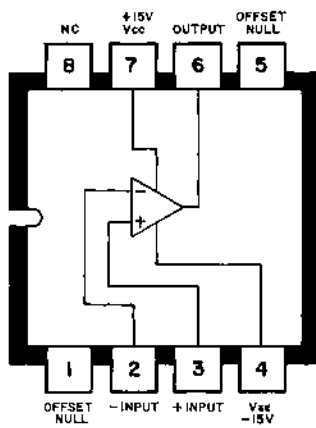

OP-AMP, HIGH SLEW
1741 / MC1741SCP

10167

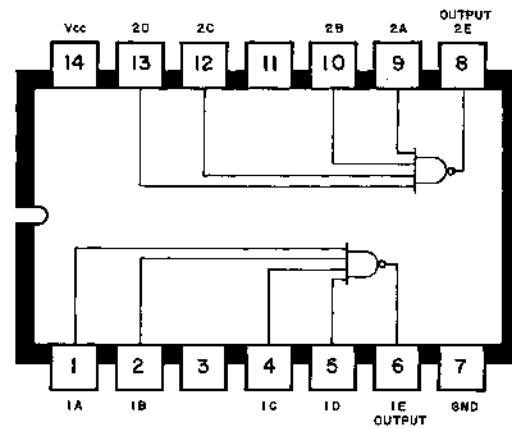

DUAL 4-INPUT NAND GATE
7420/DM7420N/SN7420N

10125

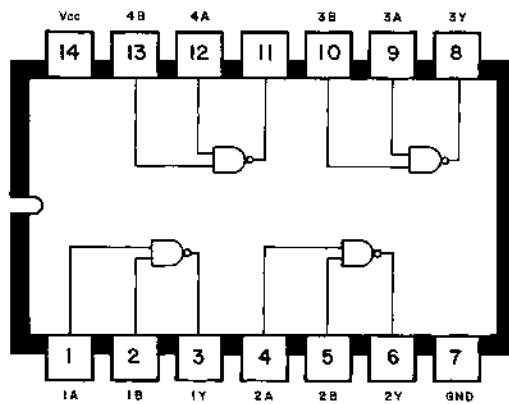

SCHEMATIC (each gate)

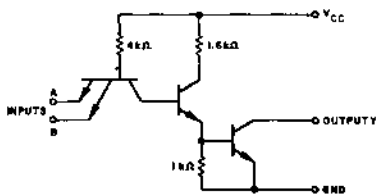

COMPONENT VALUES SHOWN ARE NOMINAL

QUAD 2-INPUT NAND GATE
±15V HI-VOLTAGE INTERFACE-OPEN COLLECTOR
7426 / SN7426N

10120

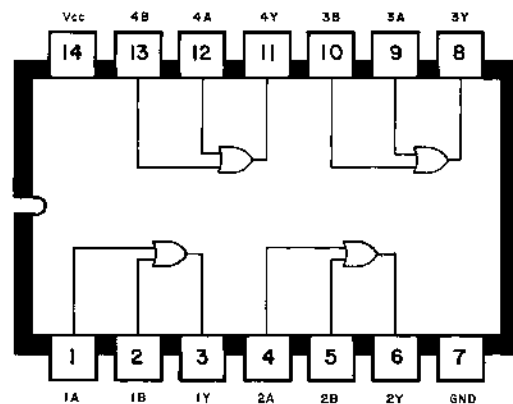

SCHEMATIC (each gate)

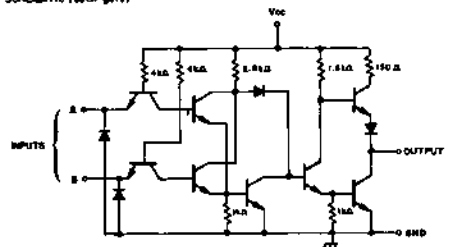

QUAD 2-INPUT OR GATE
7432 / SN7432N

10302

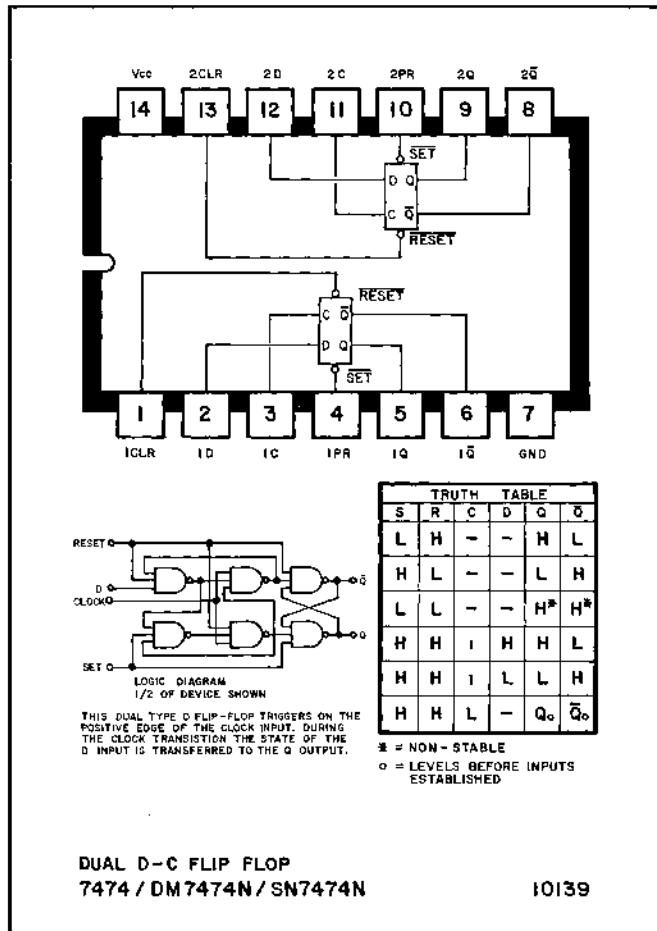
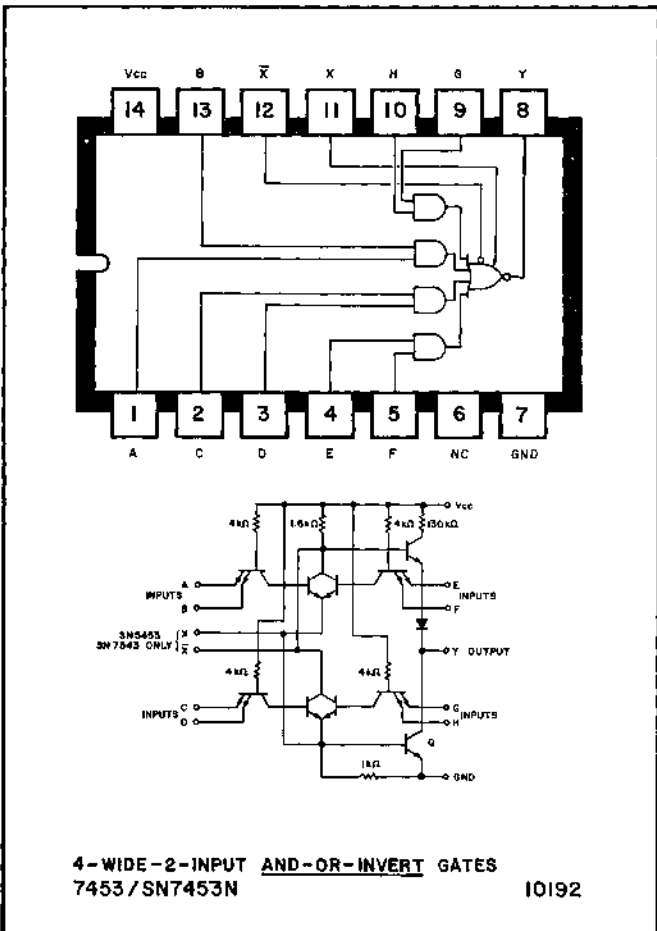
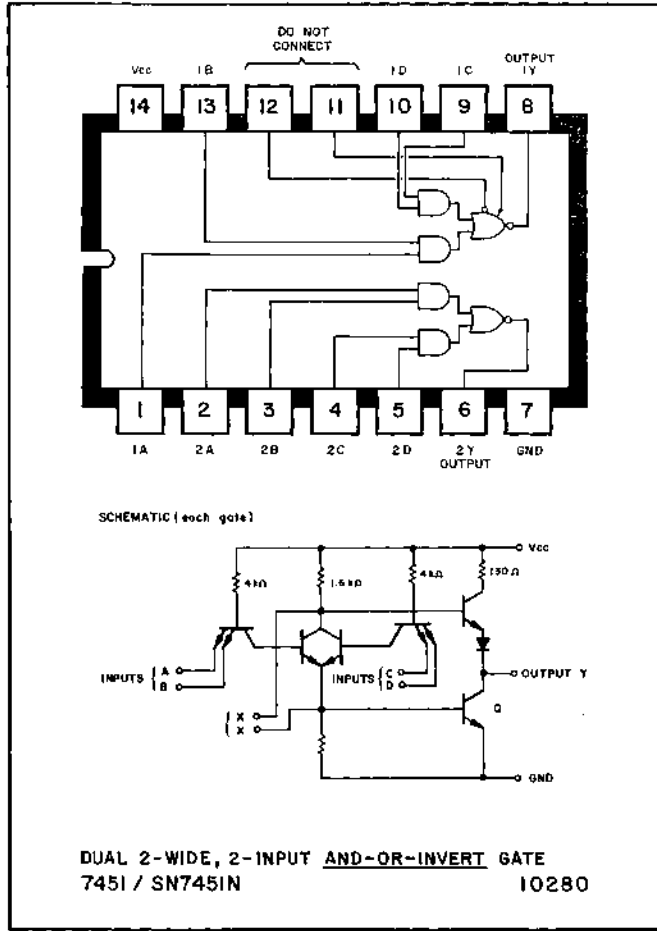
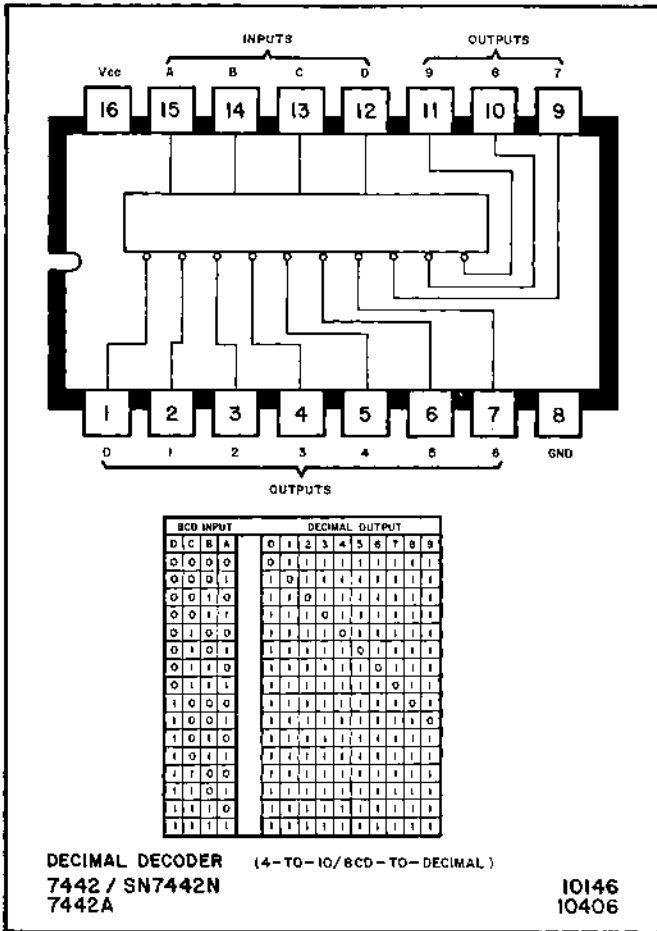

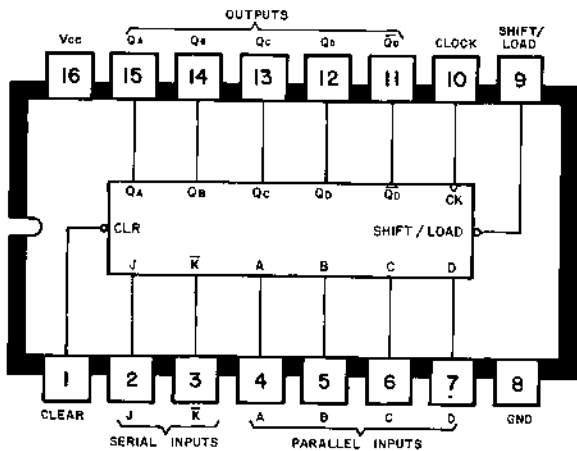

These 4-bit registers feature parallel inputs, parallel outputs, J-K serial inputs, shift/load control input, and a direct overriding clear. The registers have two modes of operation:

Parallel (Broadside) Load

Shift (in direction Q_A toward Q_D)

Parallel loading is accomplished by applying the four bits of data and taking the shift/load control input low. The data is loaded into the associated flip-flop and appears at the outputs after the positive transition of the clock input. During loading, serial data flow is inhibited.

Shifting is accomplished synchronously when the shift/load control input is high. Serial data for this mode is entered at the J-K inputs. These inputs permit the first stage to perform as a J-K, D, or T-type flip-flop as shown in the truth table.

TRUTH TABLE

INPUTS AT t_n		OUTPUTS AT t_{n+1}			
J	K	Q_A	Q_B	Q_C	Q_D
L	H	Q_{An}	Q_{Bn}	Q_{Cn}	Q_{Dn}
L	L	L	Q_{An}	Q_{Bn}	Q_{Cn}
H	H	H	Q_{An}	Q_{Bn}	Q_{Cn}
H	L	Q_{An}	Q_{Bn}	Q_{Cn}	Q_{Dn}

H = high level, L = low level

NOTES: A. t_1 = bit time before clock pulse
B. t_2 = bit time after clock pulse
C. Q_{An} = state of Q_A at t_n

4-BIT PARALLEL-ACCESS SHIFT REGISTERS
74195 / SN74195

10191

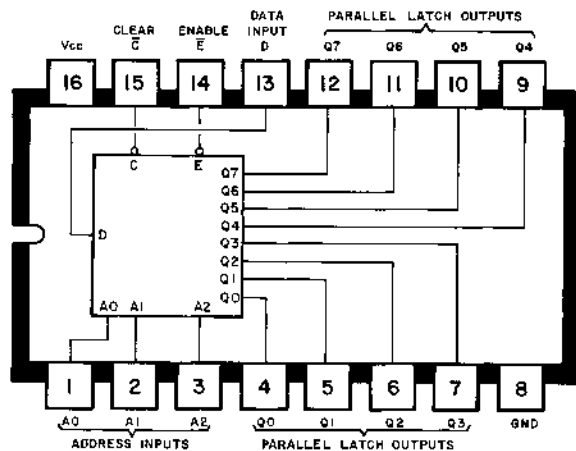

MODE SELECTION

C	E	MODE
L	H	ADDRESSABLE LATCH MEMORY
H	L	ACTIVE HIGH ENABLE CHANNEL DEMULTIPLEXER
H	H	CLEAR

TRUTH TABLE

C	E	D	A0	A1	A2	Q0	Q1	Q2	Q3	Q4	Q5	Q6	Q7	MODE
L	H	X	X	X	X	L	L	L	L	L	L	L	L	CLEAR
L	L	L	L	L	L	L	L	L	L	L	L	L	L	ADDRESSABLE
L	L	H	L	L	L	L	L	L	L	L	L	L	L	MEMORY
L	L	L	L	L	L	L	L	L	L	L	L	L	L	ADDRESSABLE LATCH

X=DON'T CARE CONDITION
L=LOW VOLTAGE LEVEL
H=HIGH VOLTAGE LEVEL
Qn-1=PREVIOUS OUTPUT STATE

8-BIT ADDRESSABLE LATCH
74259/MS19334/SN74259N

10339

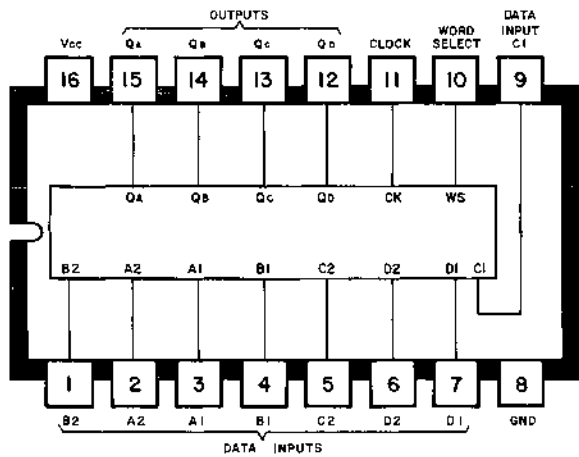

FUNCTION TABLE

INPUTS		OUTPUTS			
WORD SELECT	CLOCK	Q_A	Q_B	Q_C	Q_D
L	+	a1	b1	c1	d1
H	+	a2	b2	c2	d2
X	H	Q_{A0}	Q_{B0}	Q_{C0}	Q_{D0}

H = high level (steady state)
L = low level (steady state)
X = irrelevant (any input, including transitions)
+ = transition from high to low level
a1, a2, etc. = the level of steady-state input at a1, a2, etc.
 Q_{A0}, Q_{B0} , etc. = the level of Q_A, Q_B , etc. entered on the most-recent transition of the clock input.

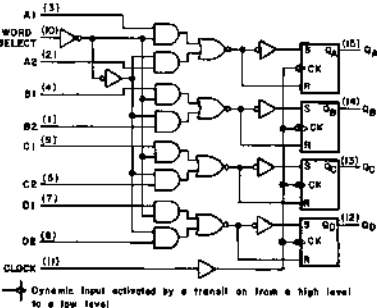

QUAD 2-INPUT MULTIPLEXER WITH STORAGE
74298 / SN74298N

10196

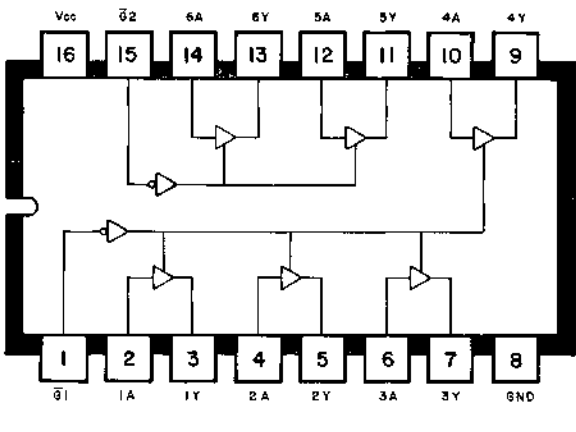

HEX TRI-STATE BUSS DRIVERS
74367 / SN74367N

10197

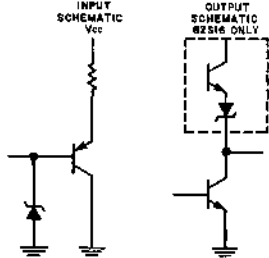
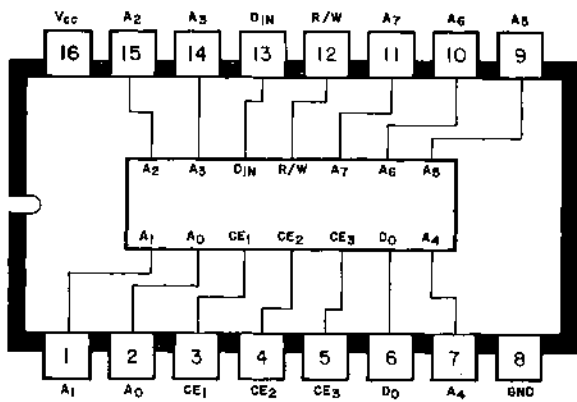

256 BIT BIPOLAR RAM (256X1 RAM)(82S16 TRI-STATE)
8216 / 82S16 42339

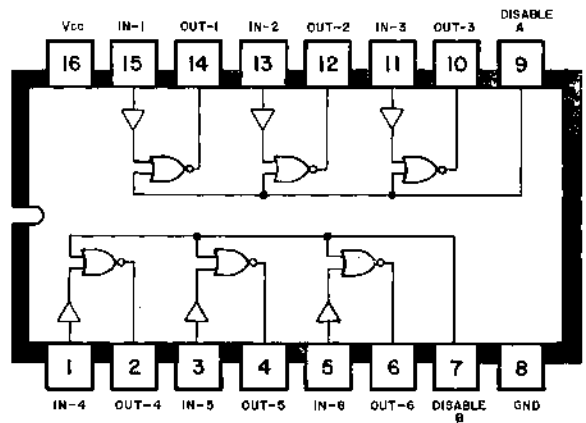

HEX UNIFIED BUS RECIEVER
8837/DM8837N

10198

(SEE 747C/10165 FACTORY SELECTED)

DUAL OP-AMP. LOW OFFSET
72747

13072

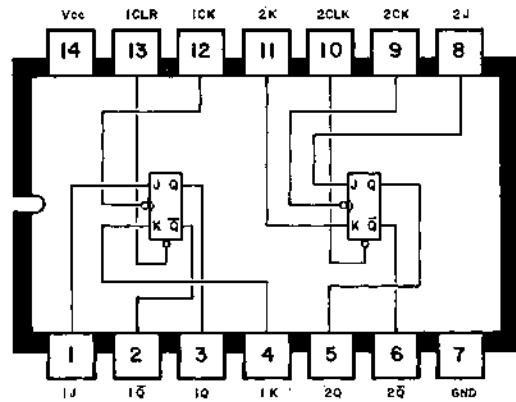

TRUTH TABLE						
CLR	CK	J	K	Q	Q̄	Q̄₀
L	-	-	-	L	H	
H	∩	L	L	Q₀	Q̄₀	
H	∩	H	L	H	L	
H	∩	L	H	L	H	
H	∩	H	H	TOGGLE	TOGGLE	

∩ = LEVELS BEFORE INPUTS ESTABLISHED

DUAL JK FLIP FLOP
74107/DM74107N/SN74107N

10305

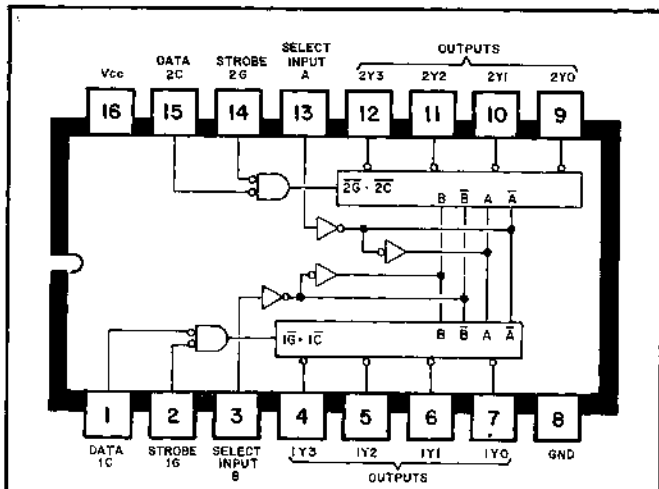

truth tables (H=high level, L=low level, X=irrelevant)

2-LINE-TO-4-LINE DECODER OR 1-LINE-TO-4-LINE DEMULTIPLEXER

INPUTS				OUTPUTS			
SELECT	STROBE	DATA		OUTPUTS			
B	A	1G	1C	1Y0	1Y1	1Y2	1Y3
H	X	H	X	H	H	H	H
L	L	L	X	L	H	H	H
L	L	L	H	L	L	H	H
L	L	L	L	L	L	L	H
H	L	L	X	H	L	H	H
H	L	L	H	H	L	L	H
H	L	L	L	H	L	L	H
X	X	X	L	H	H	H	L

INPUTS				OUTPUTS			
SELECT	STROBE	DATA		OUTPUTS			
B	A	1G	1C	2Y0	2Y1	2Y2	2Y3
X	X	H	X	H	H	H	H
L	L	L	X	L	L	L	L
L	L	L	H	L	L	L	L
L	L	L	L	L	L	L	L
H	L	L	X	H	L	L	L
H	L	L	H	H	L	L	L
H	L	L	L	H	L	L	L
X	X	X	L	H	H	H	L

DUAL 2-LINE TO 4 LINE DECODER/DEMUTIPLEXER
74155 / SN74155N

10194

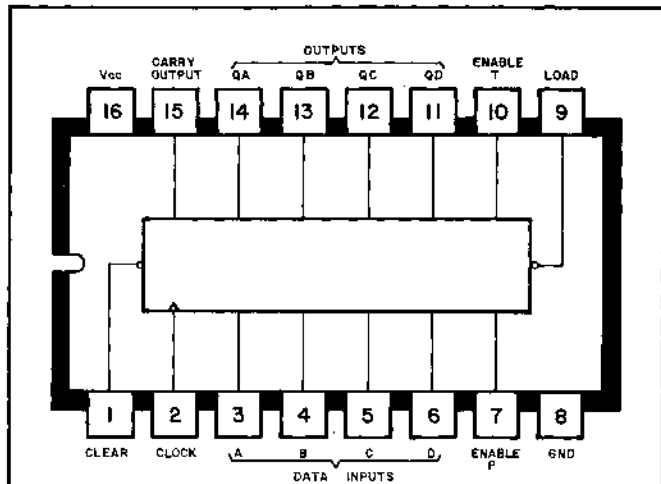

TYPICAL CLEAR, PRESET, COUNT, AND RESET SEQUENCES
SUGGESTED DELAY IS THE FOLLOWING SEQUENCE:
1. CLEAR OUTPUT TO ZERO.
2. PRESET TO DESIRED VALUE.
3. COUNT TO TARGET, DIVIDE BY, STOPPED, ZERO, ONE, AND TWO.
4. RESET.

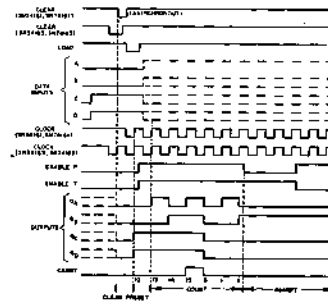

SYNCHRONOUS 4-BIT COUNTER
74161/9316PC / N74161F / SN74161N

10335

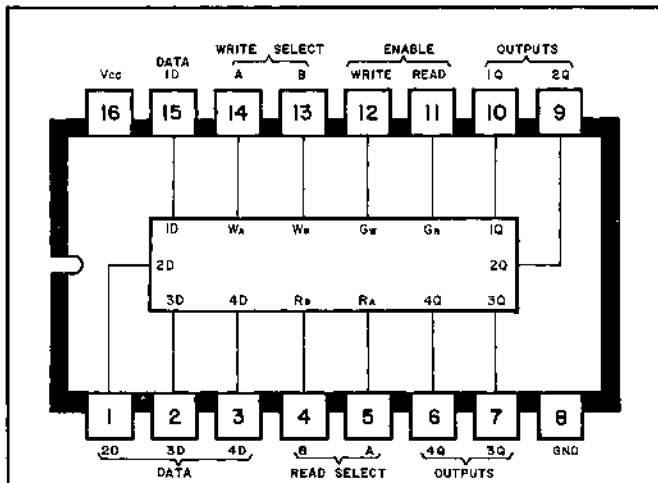

WRITE FUNCTION TABLE (SEE NOTES A, B, & C)

WRITE INPUTS				WORD			
W _B	W _A	W _R	Q	1	2	3	
L	L	L	Q=D	Q _n	Q _n	Q _n	
L	H	L	Q _n	Q=D	Q _n	Q _n	
H	L	L	Q _n	Q _n	Q=D	Q _n	
H	H	L	Q _n	Q _n	Q _n	Q=D	
X	X	H	Q _n	Q _n	Q _n	Q _n	

READ FUNCTION TABLE (SEE NOTES A & B)

READ INPUTS			OUTPUTS			
R _B	R _A	R _R	1Q	2Q	3Q	4Q
L	L	L	W0B1	W0B2	W0B3	W0B4
L	H	L	W1B1	W1B2	W1B3	W1B4
H	L	L	W2B1	W2B2	W2B3	W2B4
H	H	L	W3B1	W3B2	W3B3	W3B4
X	X	H	H	H	H	H

NOTES: A, H= high level, L= low level, X= irrelevant
B, (Q=D) = The four selected internal flip-flop outputs will assume the states applied to the four external data inputs.
C, Q_n = No change.
D, W0B1 = The first bit of word 0, etc.

4X4 REGISTER FILES OPEN COLLECTOR OUTPUT
74170 / SN74170

10195

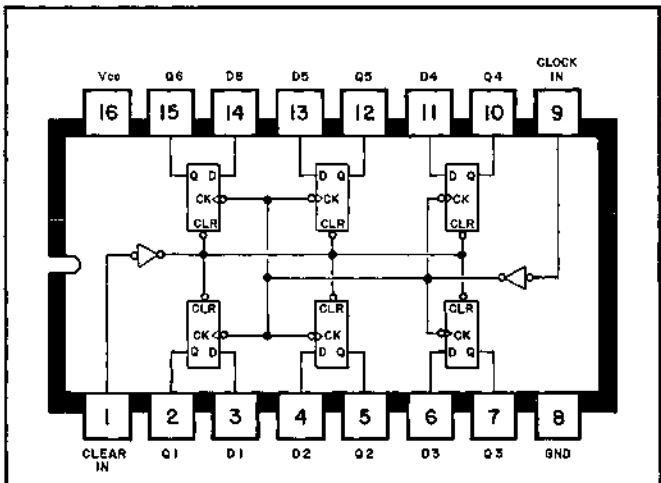

HEX. D FLIP FLOP WITH CLEAR
74174/74174PC / SN74174N

10336

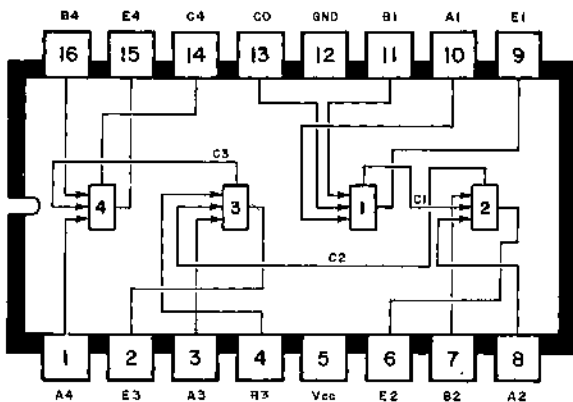

2-STATE MEMORY

ADDRESS	DATA
0000	0000
0001	0000
0010	0000
0011	0000
0100	0000
0101	0000
0110	0000
0111	0000
1000	0000
1001	0000
1010	0000
1011	0000
1100	0000
1101	0000
1110	0000
1111	0000

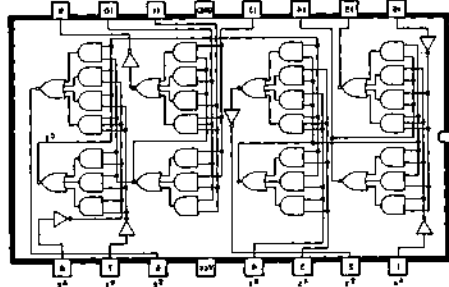

4 BIT BINARY FULL ADDER
7483/N7483B/DM7483N/SN7483A-N 10140

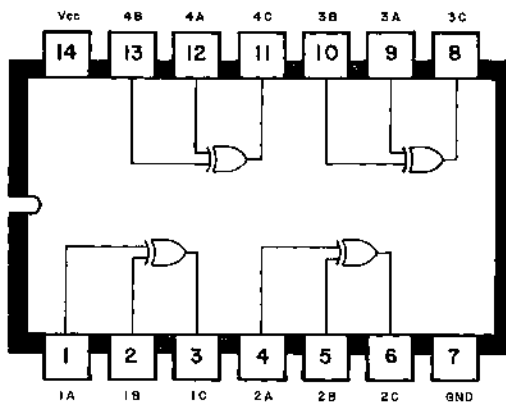

QUAD 2-INPUT EXCLUSIVE-OR GATES
7486/N7486N/DM7486N/SN7486N 10303

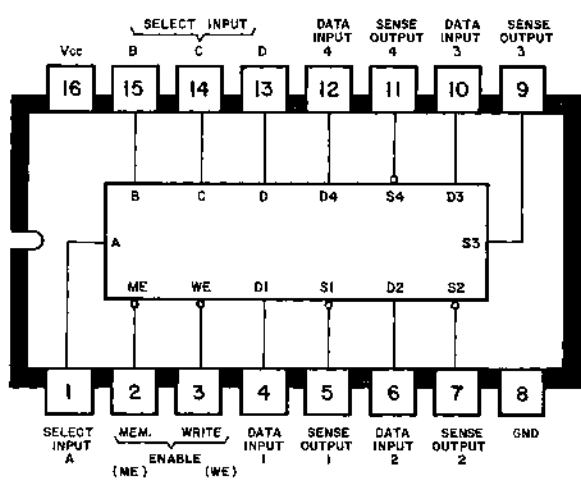

FUNCTION TABLE

ME	WE	OPERATION	CONDITION OF OUTPUTS
L	L	Write	Complement of Data Inputs
L	H	Read	Complement of Selected Word
H	L	Inhibit Storage	Complement of Data Inputs
H	H	Do Nothing	High

64 BIT READ/WRITE MEMORY (RAM)
7489/SN7489N 10193

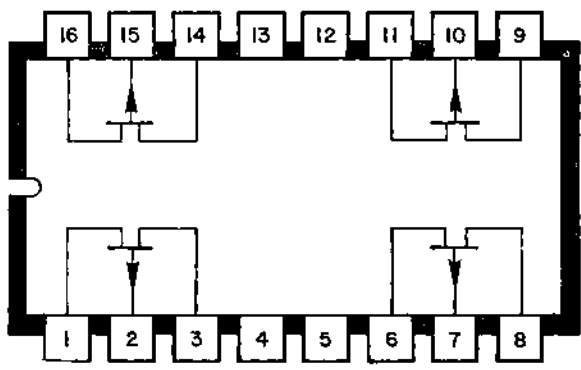

QUAD P-CHANNEL FET PACKAGE
8041/ITS7478/2170CJ002 10190

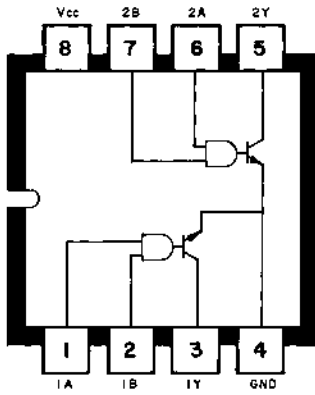

DUAL PERIPHERAL POS. NAND DRIVER
75452 / LM75452 / SN75452BP

10306

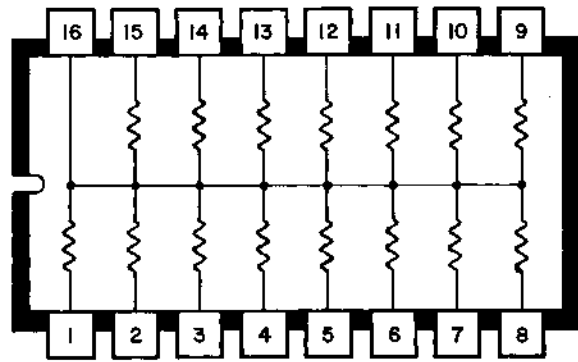

1000 Ω \pm 2% RESISTOR NETWORK

10239

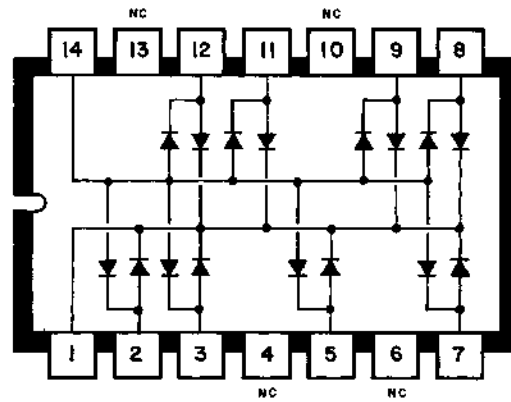



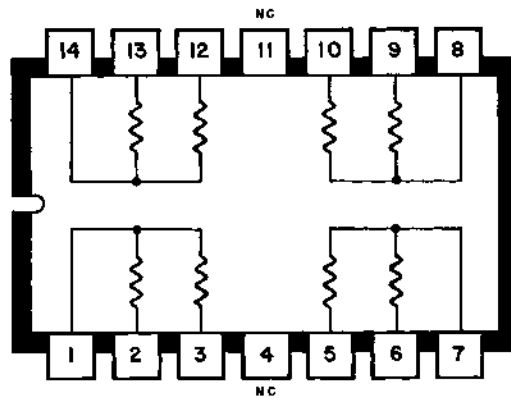

16 DIODE ARRAY





13010

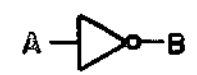

PAIRED CLOSE TOLERANCE (\pm .0015%)
RESISTOR NETWORK 10 K Ω

13044

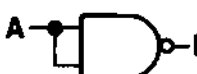
<p>AND</p>  <table border="1"> <thead> <tr><th>A</th><th>B</th><th>C</th></tr> </thead> <tbody> <tr><td>H</td><td>L</td><td>L</td></tr> <tr><td>L</td><td>H</td><td>L</td></tr> <tr><td>L</td><td>L</td><td>L</td></tr> <tr><td>H</td><td>H</td><td>H</td></tr> </tbody> </table>	A	B	C	H	L	L	L	H	L	L	L	L	H	H	H	<p>NAND</p>  <table border="1"> <thead> <tr><th>A</th><th>B</th><th>C</th></tr> </thead> <tbody> <tr><td>L</td><td>H</td><td>H</td></tr> <tr><td>H</td><td>L</td><td>H</td></tr> <tr><td>H</td><td>H</td><td>L</td></tr> <tr><td>L</td><td>L</td><td>H</td></tr> </tbody> </table>	A	B	C	L	H	H	H	L	H	H	H	L	L	L	H	<p>OR</p>  <table border="1"> <thead> <tr><th>A</th><th>B</th><th>C</th></tr> </thead> <tbody> <tr><td>H</td><td>L</td><td>H</td></tr> <tr><td>L</td><td>H</td><td>H</td></tr> <tr><td>H</td><td>H</td><td>H</td></tr> <tr><td>L</td><td>L</td><td>L</td></tr> </tbody> </table>	A	B	C	H	L	H	L	H	H	H	H	H	L	L	L	<p>NOR</p>  <table border="1"> <thead> <tr><th>A</th><th>B</th><th>C</th></tr> </thead> <tbody> <tr><td>H</td><td>L</td><td>L</td></tr> <tr><td>L</td><td>H</td><td>L</td></tr> <tr><td>H</td><td>H</td><td>L</td></tr> <tr><td>L</td><td>L</td><td>H</td></tr> </tbody> </table>	A	B	C	H	L	L	L	H	L	H	H	L	L	L	H	<p>EXCLUSIVE OR</p>  <table border="1"> <thead> <tr><th>A</th><th>B</th><th>C</th></tr> </thead> <tbody> <tr><td>H</td><td>L</td><td>H</td></tr> <tr><td>L</td><td>H</td><td>H</td></tr> <tr><td>H</td><td>H</td><td>L</td></tr> <tr><td>L</td><td>L</td><td>L</td></tr> </tbody> </table>	A	B	C	H	L	H	L	H	H	H	H	L	L	L	L	 <table border="1"> <thead> <tr><th>A</th><th>B</th></tr> </thead> <tbody> <tr><td>H</td><td>L</td></tr> <tr><td>L</td><td>H</td></tr> </tbody> </table>	A	B	H	L	L	H
A	B	C																																																																																				
H	L	L																																																																																				
L	H	L																																																																																				
L	L	L																																																																																				
H	H	H																																																																																				
A	B	C																																																																																				
L	H	H																																																																																				
H	L	H																																																																																				
H	H	L																																																																																				
L	L	H																																																																																				
A	B	C																																																																																				
H	L	H																																																																																				
L	H	H																																																																																				
H	H	H																																																																																				
L	L	L																																																																																				
A	B	C																																																																																				
H	L	L																																																																																				
L	H	L																																																																																				
H	H	L																																																																																				
L	L	H																																																																																				
A	B	C																																																																																				
H	L	H																																																																																				
L	H	H																																																																																				
H	H	L																																																																																				
L	L	L																																																																																				
A	B																																																																																					
H	L																																																																																					
L	H																																																																																					

 <table border="1"> <thead> <tr><th>A</th><th>B</th><th>C</th></tr> </thead> <tbody> <tr><td>H</td><td>L</td><td>L</td></tr> <tr><td>L</td><td>H</td><td>L</td></tr> <tr><td>L</td><td>L</td><td>L</td></tr> <tr><td>H</td><td>H</td><td>H</td></tr> </tbody> </table>	A	B	C	H	L	L	L	H	L	L	L	L	H	H	H	 <table border="1"> <thead> <tr><th>A</th><th>B</th><th>C</th></tr> </thead> <tbody> <tr><td>L</td><td>H</td><td>H</td></tr> <tr><td>H</td><td>L</td><td>H</td></tr> <tr><td>H</td><td>H</td><td>L</td></tr> <tr><td>L</td><td>L</td><td>H</td></tr> </tbody> </table>	A	B	C	L	H	H	H	L	H	H	H	L	L	L	H	 <table border="1"> <thead> <tr><th>A</th><th>B</th><th>C</th></tr> </thead> <tbody> <tr><td>H</td><td>L</td><td>L</td></tr> <tr><td>L</td><td>H</td><td>L</td></tr> <tr><td>H</td><td>H</td><td>L</td></tr> <tr><td>L</td><td>L</td><td>H</td></tr> </tbody> </table>	A	B	C	H	L	L	L	H	L	H	H	L	L	L	H	 <table border="1"> <thead> <tr><th>A</th><th>B</th></tr> </thead> <tbody> <tr><td>H</td><td>L</td></tr> <tr><td>L</td><td>H</td></tr> </tbody> </table>	A	B	H	L	L	H	 <table border="1"> <thead> <tr><th>A</th><th>B</th></tr> </thead> <tbody> <tr><td>H</td><td>L</td></tr> <tr><td>L</td><td>H</td></tr> </tbody> </table>	A	B	H	L	L	H	 <table border="1"> <thead> <tr><th>A</th><th>B</th></tr> </thead> <tbody> <tr><td>L</td><td>H</td></tr> <tr><td>H</td><td>L</td></tr> </tbody> </table>	A	B	L	H	H	L
A	B	C																																																																		
H	L	L																																																																		
L	H	L																																																																		
L	L	L																																																																		
H	H	H																																																																		
A	B	C																																																																		
L	H	H																																																																		
H	L	H																																																																		
H	H	L																																																																		
L	L	H																																																																		
A	B	C																																																																		
H	L	L																																																																		
L	H	L																																																																		
H	H	L																																																																		
L	L	H																																																																		
A	B																																																																			
H	L																																																																			
L	H																																																																			
A	B																																																																			
H	L																																																																			
L	H																																																																			
A	B																																																																			
L	H																																																																			
H	L																																																																			

J-K FLIP FLOP

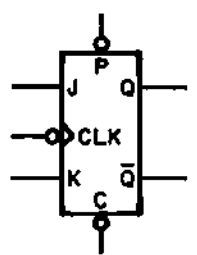

CK	J	K	P	C	Q	Q̄
-	-	-	L	H	H	L (SET)
-	-	-	H	L	L	H (RES.)
L	H	L	H	H	H	L
L	L	H	H	H	L	H
L̄	H	H	H	H	TOGGLE	

D-C FLIP FLOP

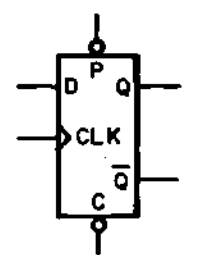

D	C	S	P	C	Q̄
-	-	L	H	H	L
-	-	H	L	L	H
-	-	L	L	H*	H*
H	J	H	H	H	L
L	J̄	H	H	L	H

* = NON-STABLE

R-S FLIP FLOP

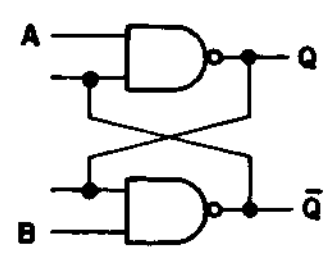

A	B	Q	Q̄
H	L	L	H
H	H	L	H
L	H	H	L
H	H	H	L

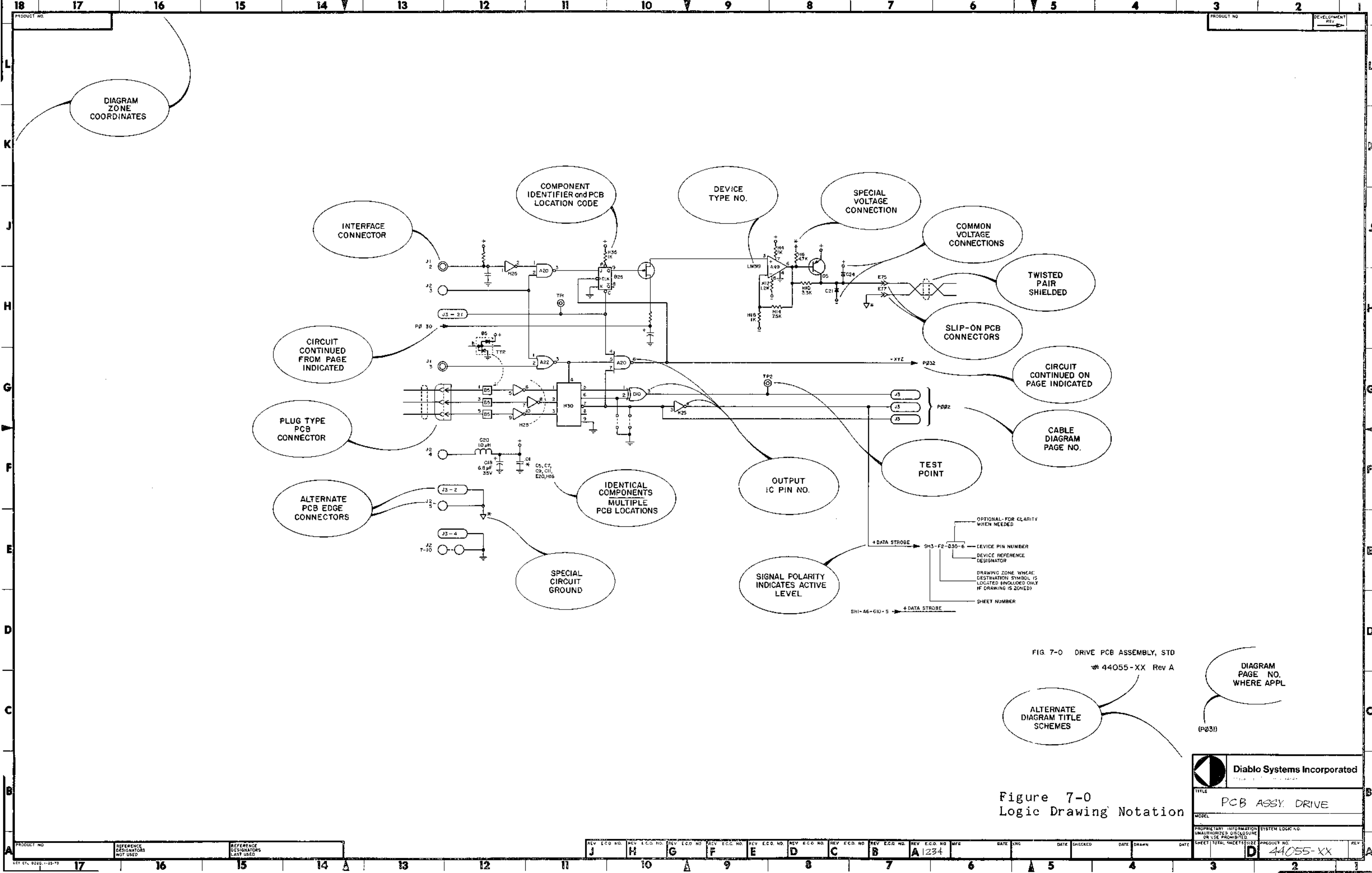

FIG 7-0 DRIVE PCB ASSEMBLY, STD
44055-XX Rev A

ALTERNATE
DIAGRAM TITLE
SCHEMES

DIAGRAM
PAGE NO.
WHERE APPL.

(P031)

Figure 7-0
Logic Drawing Notation

Diablo Systems Incorporated <small>ESTABLISHED 1964</small>	
TITLE PCB ASSY. DRIVE	
MODEL	
PROPRIETARY INFORMATION UNAUTHORIZED DISCLOSURE OR USE PROHIBITED	SYSTEM LOG# NO.
SHEET TOTAL SHEETS SIZE D 44055-XX	PRODUCT NO.

REV. E.C.D. NO.	REV. I.C.D. NO.	REV. E.C.D. NO.	REV. E.C.D. NO.	REV. E.C.D. NO.	REV. E.C.D. NO.	REV. E.C.D. NO.	REV. E.C.D. NO.	REV. E.C.D. NO.	REV. E.C.D. NO.	REV. E.C.D. NO.	MFR.	DATE	ENG.	DATE	CHECKED	DATE	DRAWN	DATE	
J	H	G	F	E	D	C	B	A	1234										

PRODUCT NO.	REFERENCE DESIGNATORS NOT USED	REFERENCE DESIGNATORS LAST USED

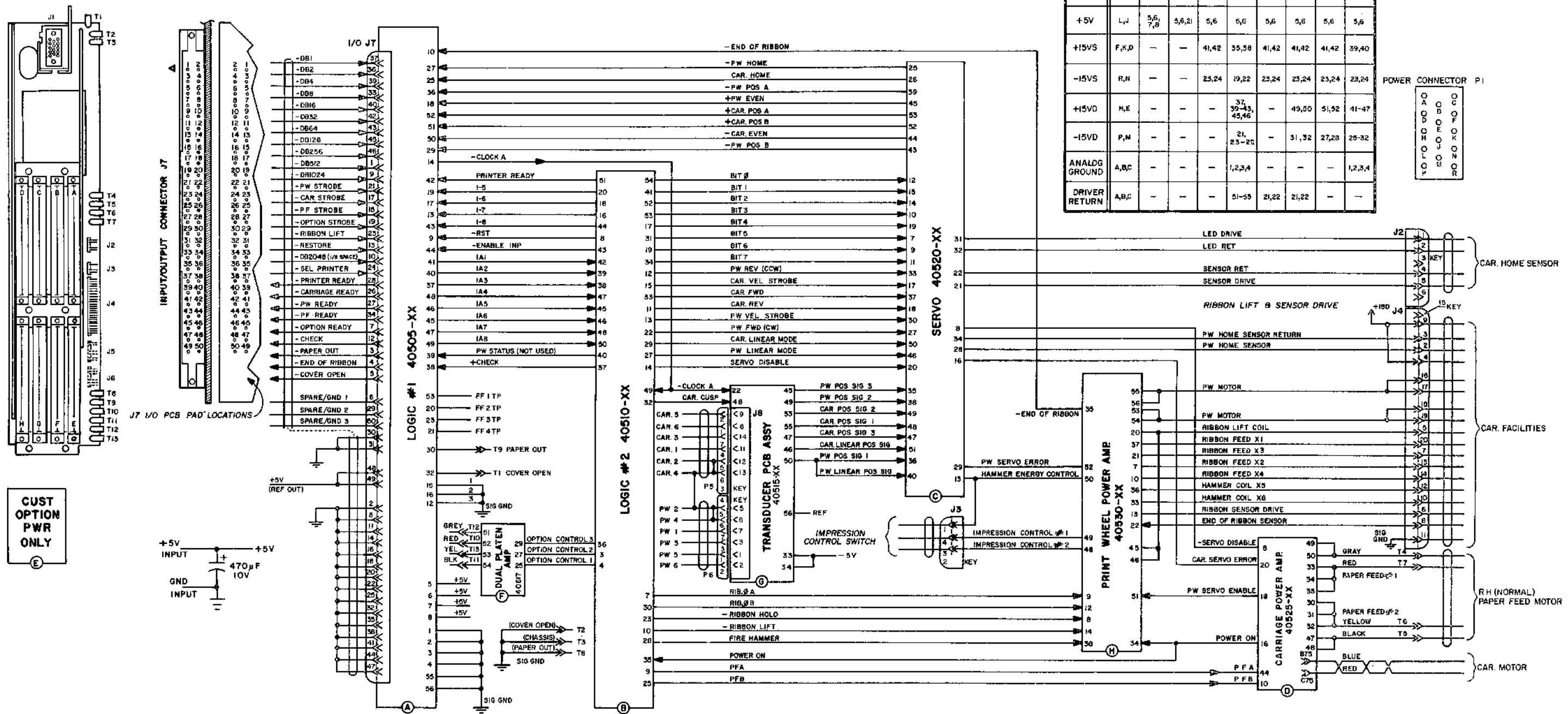

POWER DISTRIBUTION CHART
CARD LOCATION

VOLTAGE	J1	A	B	C	D	E	F	G	H
SIGNAL GROUND	A,B,C	1,2,3,4,55,56	1,2,3,4,55,56	1,2,3,4,55,56	-	1,2,3,4,55,56	1,2,3,4,55,56	1,2,3,4	-
+5V	L,J	5,6,7,8	5,6,21	5,6	5,6	5,6	5,6	5,6	5,6
+15VS	F,K,D	-	-	41,42	35,38	41,42	41,42	41,42	39,40
-15VS	R,N	-	-	23,24	19,22	23,24	23,24	23,24	23,24
+15VD	H,E	-	-	-	37,39-43,45,46	-	49,50	51,52	41-47
-15VD	P,M	-	-	-	21,23-25	-	31,32	27,28	29-32
ANALOG GROUND	A,B,C	-	-	-	1,2,3,4	-	-	-	1,2,3,4
DRIVER RETURN	A,B,C	-	-	-	51-55	21,22	21,22	-	-

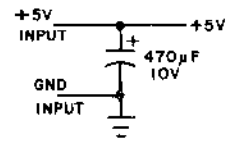
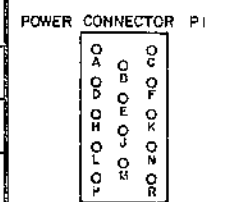

Figure 7-1a
Motherboard PCB Assy, Standard #40500-XX
Rev F

Figure 7-1a Motherboard PCB Assy, Std
#40500-XX Rev F

REVISION HISTORY:

REV.	ECO#	ETCH	CONFIGURATION
A	9529	--	B/M as released.
B	9612	01	Schematic and Assembly as released. Revise B/M to match schematic.
C	9639	02	Eliminate signal ground to chassis ground connection, and add connector for Split Platen or Test PCB. Revise B/M.
D	9685	03	Add ground and power to Split Platen PCB connector.
E	9689	05	Revise PCB to include Rev. D additions.
F	9715	06	Cut traces and add twisted pair wires to eliminate PCB noise. Change B/M.
G	9770	06	Add signal wire jumper from C8 to D8 to facilitate servo noise fix.
H	9802	07	Revise PCB to include Rev. G additions.
J	9811	07	Revise schematic to include use of #40515-XX Transducer PCB in place of #24295-XX Transducer PCB.
K	9911	07	Revise assembly and B/M for lowered Motherboard installation.
L	A1061		Delete twisted pair wires used with #24295-XX PCB, B/M.
M	A1173	08	-XX to -03 at Rev. A.
A	A1173	08	-03 configuration. Color code Paper Feed motor leads, and change connector J2 from 5 to 6 pin. Redraw B/M.
B	A1244	08	Change wire color T12 from gray to red; T10 from red to gray, for correct paper feed direction when used with split platen.
A	A3121	09	Allow temporary use of -04 configuration (-08 etch) Include 470 uFd capacitor +5V to ground to reduce noise. Release -05 configuration (-09 etch) to incorporate -04 changes. Change wire color code for Split Platen paper feed motor leads: T10 to Red, T11 to Black, T12 to Grey, and T13 to Yellow.
B	A3287	09	Change power supply connector to a style with reversed jack screws to aid proper connector orientation.
C	A3715	09	Clarify documentation. Establish tab bend angle.
D	B1077	09	Documentation change. Allow use of connector with shorter pins.
E	B1191	09	Change part number to 40500-XX; add -06 assembly with connector in slot E.
F	B1362	09	Hardware change only

SOLID STATE COMPONENTS USED:

(No solid state components listed)

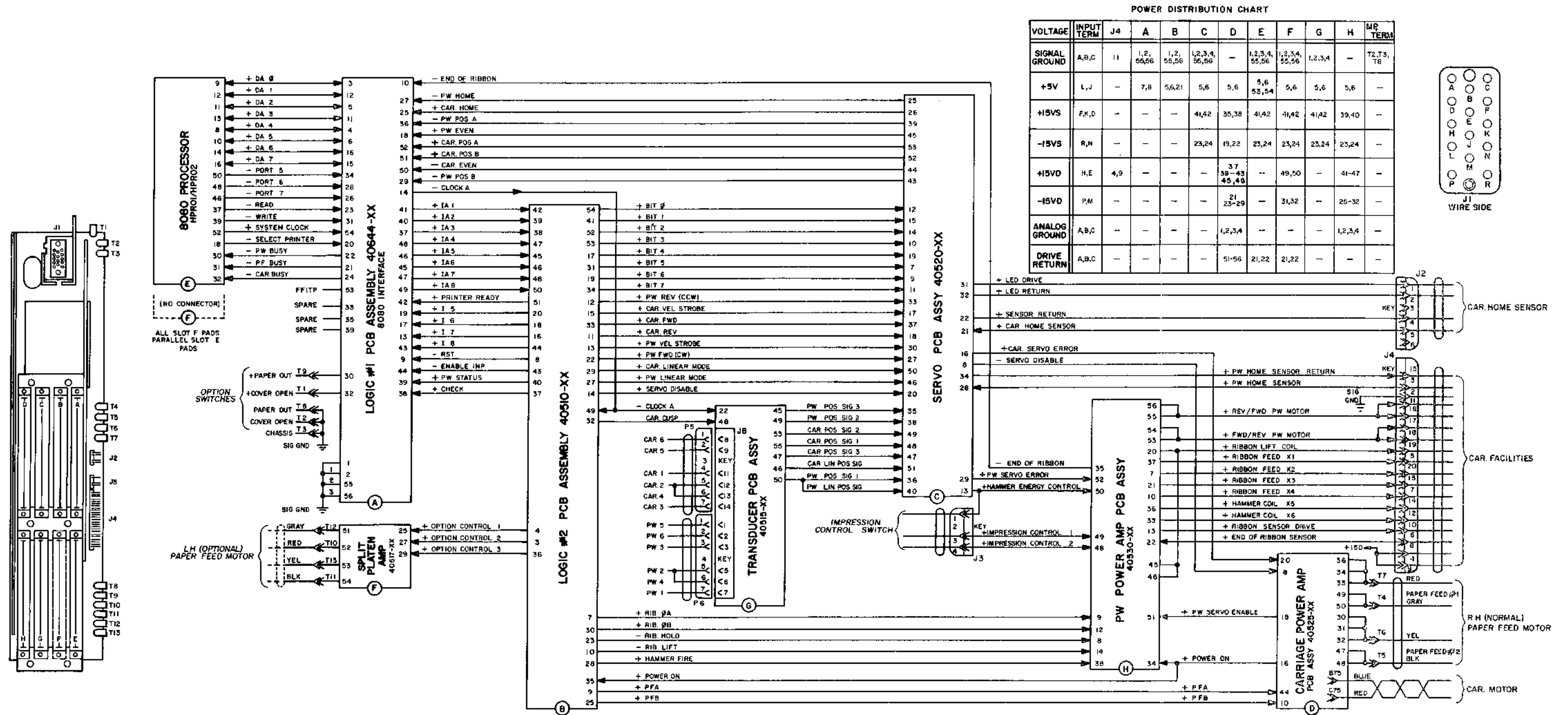

Figure 7-1b
 Motherboard PCB Assy, 8080
 #40614-04 Rev H

Figure 7-1b Motherboard PCB Assy, 8080
#40614-04 Rev H

REVISION HISTORY:

REV.	ECO#	ETCH	CONFIGURATION
A	9853	01	As released, with B/M.
B	9877	01	-XX to -02 configuration. Cut traces and add twisted pair wires, and add jumper from C8 to D8 to facilitate noise fixes.
C	9911	01	-02 to -03 configuration. Revise assembly and B/M for lowered Motherboard installation.
D	A1028	01	-03 to -04 configuration. Delete twisted pair wires and trace cuts used with #24295-XX PCB.
E	A1290	01	Delete "FF2TP", "FF3TP", and "FF4TP" from schematic.
F	A3271	01	Chg to correct documentation.
G	B1051	01	Bend connector tabs 45° to facilitate installation and reduce breakage.
G1	B1147	01	Correct documentation error.
H	B1362	01	Hardware change only.

SOLID STATE COMPONENTS USED:

(No solid state components listed)

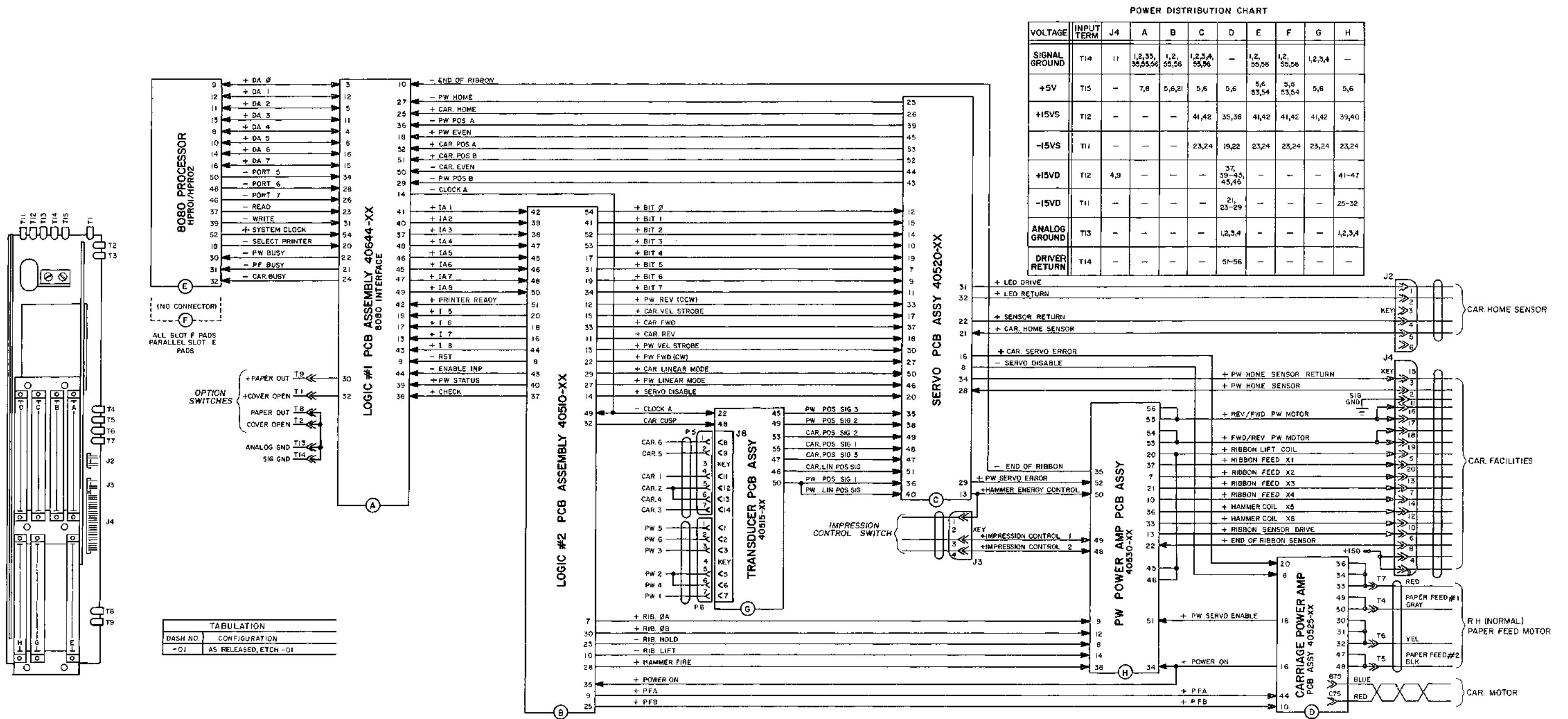

Figure 7-1c
 Motherboard PCB Assy, Systems
 #46080-01
 Rev C

Figure 7-1c Motherboard PCB Assy, Systems
#46080-01 Rev C

REVISION HISTORY:

REV. ECO# ETCH CONFIGURATION

A	A1759	01	As released.
B	A1869	01	Correct part number callout on B/M.
C	A3603	01	To clarify production instructions.

SOLID STATE COMPONENTS USED:

(No solid state components listed)

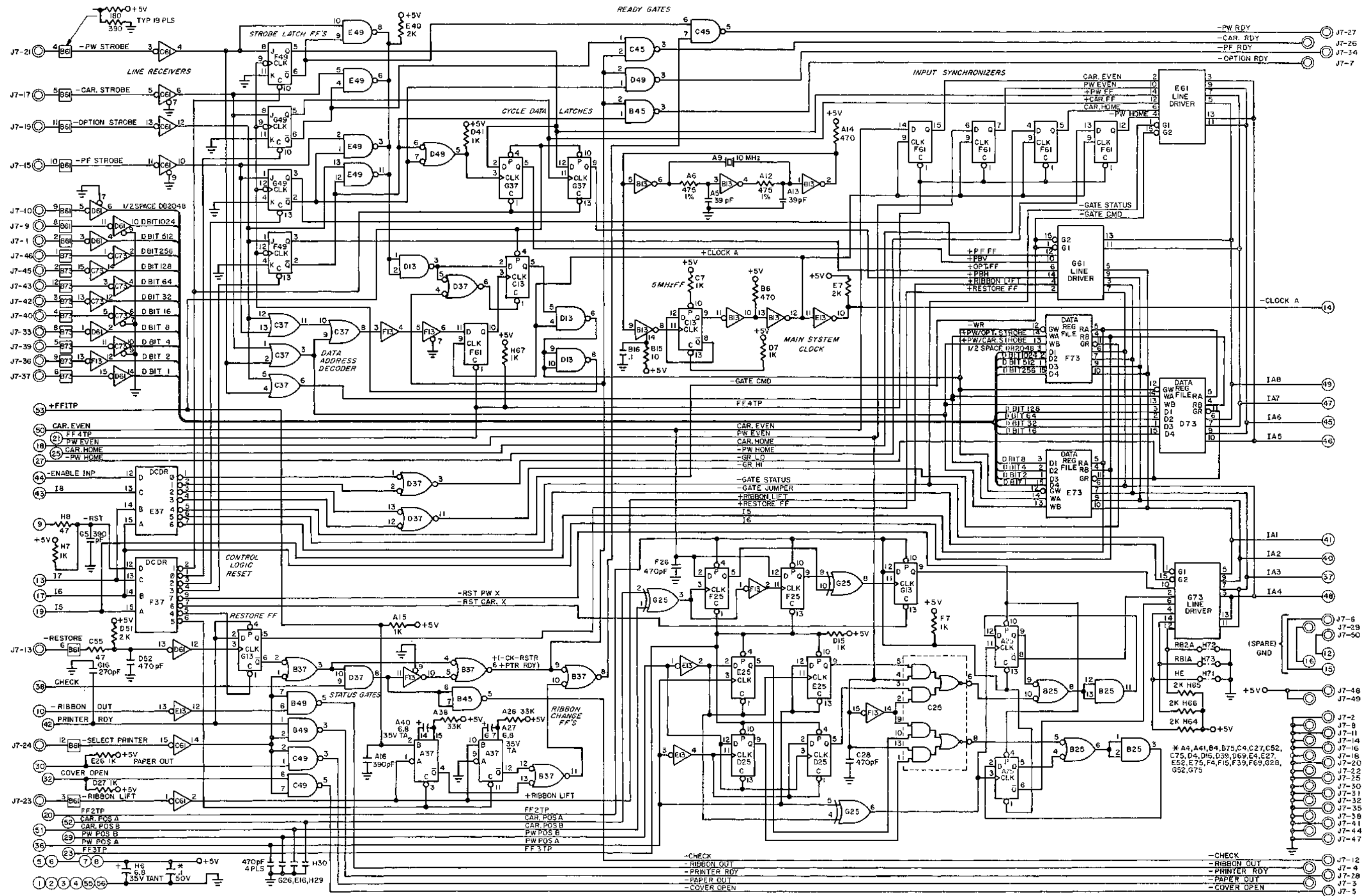

Figure 7-2a
 Logic #1 PCB Assy, Standard
 #40505-09
 Rev B

Figure 7-2a Logic #1 PCB Assy, Std ESD
 #40505-09 Rev B

REVISION HISTORY:

REV.	ECO#	ETCH	CONFIGURATION
A	9614	01	B/M and Assembly as released.
B	9641	01	Schematic as released. Change to 2% resistors for standardization. Revise B/M.
C	9662	01	Change from Mylar to ceramic capacitors for standardization. Revise B/M.
D	9690	01	Correct error, E25-14 and E25-15 reversed.
E	9701	01	Correct error, H50 and H51 reversed.
F	9734	02	Allow use of either -01 or -02 PCB etch. Revise B/M.
G	9762	02	Delete capacitor H28 to speed up RESTORE strobe. Change B/M.
H	9882	02	Change to low power Schottky TTL devices to reduce +5 volt current demand, and lower power dissipation. Revise B/M.
J	9952	02	Change G13 from 74LS04 to 7404 device to avoid marginal TTL load distribution. Revise B/M.
J1	A1133	02	Delete use of low power Schottky devices at B25, E13, E61, E73 and G25. Change B/M.
J2	A1352	03	Allow use of -03 etch in -05/-06 assembly (new layout). Added two 470pF capacitors.
K	A1216	04	-XX to -04 configuration. Revise strobe input digital filter circuit, ribbon lift logic, increment/decrement logic, and remove diodes on input circuits.
L	A1372	05	-04 to -07 configuration. Add noise immunity filter capacitors to transducer input lines, and increase time-out for Ribbon Lift FF. Revise B/M.
M	A3704	05	Documentation change only.
N	A3841	05	Documentation change only.
P	B1244	05	Capacitor H28 deleted.
R	B1321	05	Reverse polarity of capacitors H33 and H37.
A	B1308	05	Rework -07 to -08 configuration to incorporate ESD modifications.
A	B1450	06	Release -09 configuration, -06 Etch. Relay out to incorporate -08 ESD changes.
B	B1538	06	Documentation changes only.

SOLID STATE COMPONENTS USED:

IC's		
74LS221		H49
74LS74		A13,C13,C25,D13,D25,G61,H61
74LS367		A37,E37,F37
7451		B13
7486		B25
74LS170		B37,C37,D37
8837		C49,C61,C73,H25
7408		E13,G25
74LS42		E49,F49
7426		E61
74LS174		E25
7432		E73
74LS107		F61,F73
7404		G13
75452		G37,G45,G49,G69,G73
7400		A25,H73
Resistor Pack		B49,B61,B73,D49,D73
Diodes		(No components listed)
Transistors		(No components listed)

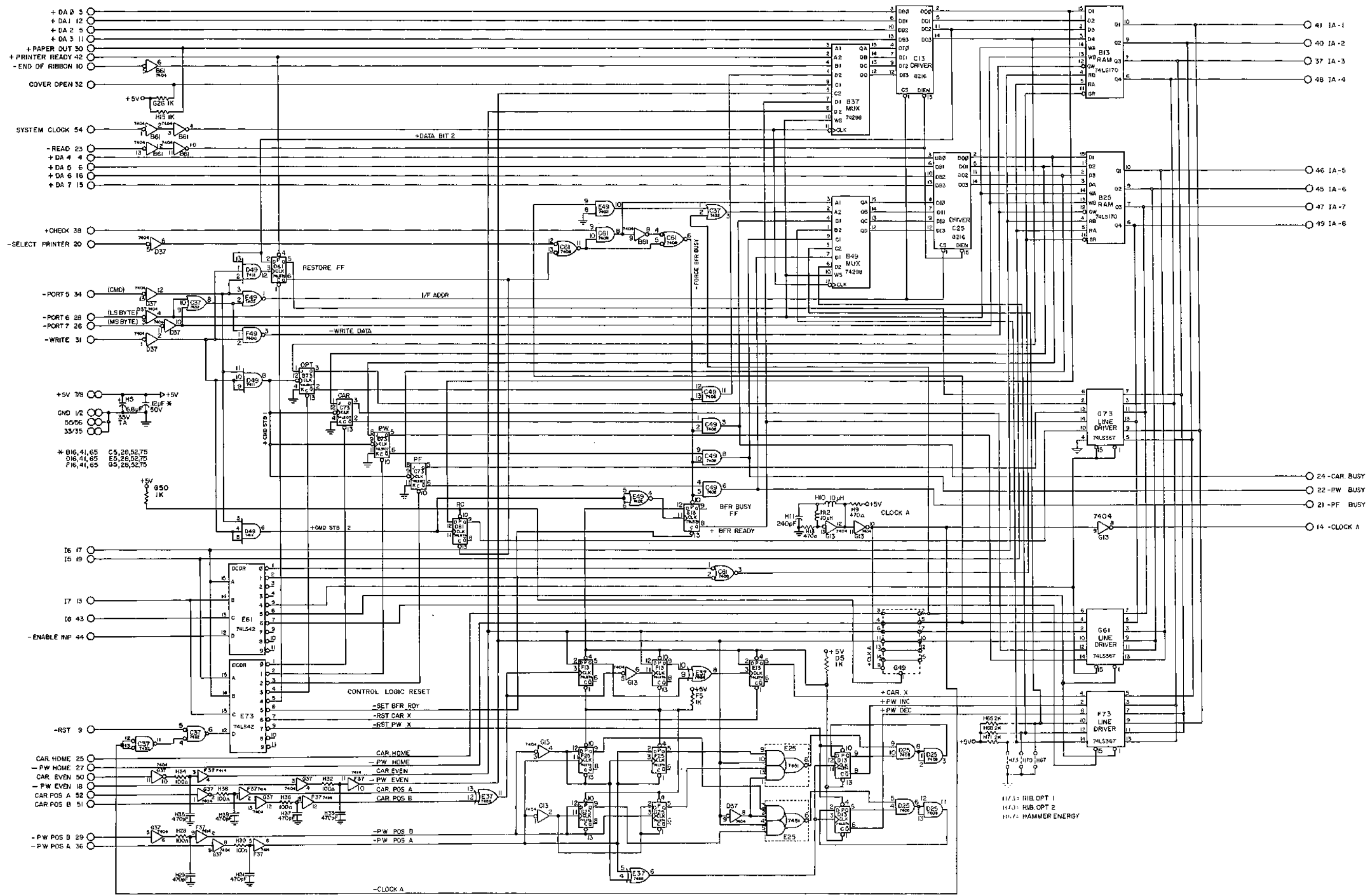

Figure 7-2b
 Logic #1 PCB Assy, 8080
 #40644-05 Rev B

Figure 7-2b Logic #1 PCB Assy, 8080
#40644-05 Rev B

REVISION HISTORY:

REV.	ECO#	ETCH	CONFIGURATION
A	9879	01	As released.
B	A1076	01	Correct PCB artwork error.
C	A1096	01	Cut traces and add jumpers to improve noise immunity, and revise "Busy/Done" logic.
D	A1120	02	Allow manual print wheel position change without loss of microprocessor PW position memory.
A	A3103	02	Rework to -04 configuration to relieve noise problem.
A	A3103	03	Release -05 configuration (-03 etch) to incorporate -04 changes.
B	A3879	03	Documentation change only.

SOLID STATE COMPONENTS USED:

IC's	7414	F37
	7400	F49
	7402	E49
	7404	B61,D37,G13,G37
	7408	C49,C61,D25
	7411	D49
	7432	C37
	74LS42	E61,E73
	7451	E25
	74LS74	D13,D61,E13,F13,F25,G25
	7486	E37
	74LS107	B73,C73
	74LS170	B13,B25
	74298	B37,B49
	74LS367	F73,G61,G73
	8216	C13,C25

Diodes (No components listed)

Transistors (No components listed)

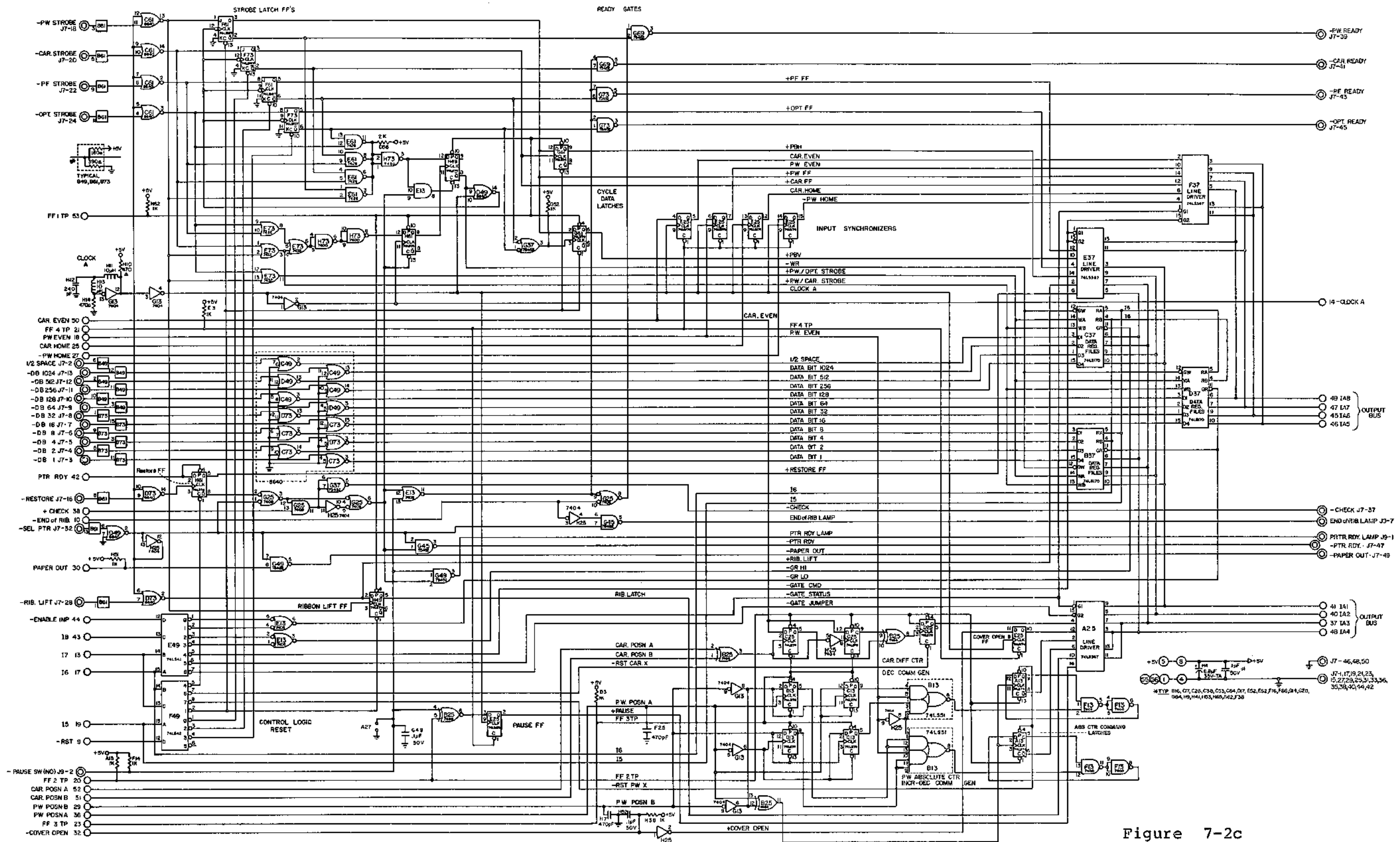

Figure 7-2c
 Logic #1 PCB Assy, Spec. D
 #40725-05 Rev A

REVISION HISTORY:

REV.	ECO#	ETCH	CONFIGURATION
A	----	--	(not used)
B	9886	01	As released.
C	A1038	01	Revise ribbon lamp logic to include inverter H25-3 to change output from "OK" to "OUT".
D	9991	03	Circuit changes and relayout per customer request.
E	A1171	03	-XX to -04 configuration. Delete use of low power Schottky devices where not needed.
F	A1231	03	Change B13 from type 7486 to type 74LS51.
G	A1534	03	Change G13 and H25 from type 74LS04 to type 7404.
H	A3705	03	Documentation change only. A37 to A25 on drawing.
J	A3841	03	Documentation change only.
A	A3987	03	Move capacitor A27 to pins 1 and 4 of G49. Relabel as G49. Alleviate intermittent "Ready" light. No schematic change.

SOLID STATE COMPONENTS USED:

IC's	74LS74	A13,C13,C25,D13,D25,G61,H49,H61
	7404	G13,H25
	74LS367	A25,E37,F37
	74LS51	B13
	7486	B25
	74LS170	B37,C37,D37
	7408	E13,G25
	8640	C49,C61,C73,D49,D73
	74LS42	E49,F49
	7426	E61
	74LS174	E25
	7432	E73
	74LS107	F61,F73
	75452	G37,G45,G49,G69,G73
	7400	F13,H73
	Resistor Pack	B49,B61,B73

Diodes (No components listed)

Transistors (No components listed)

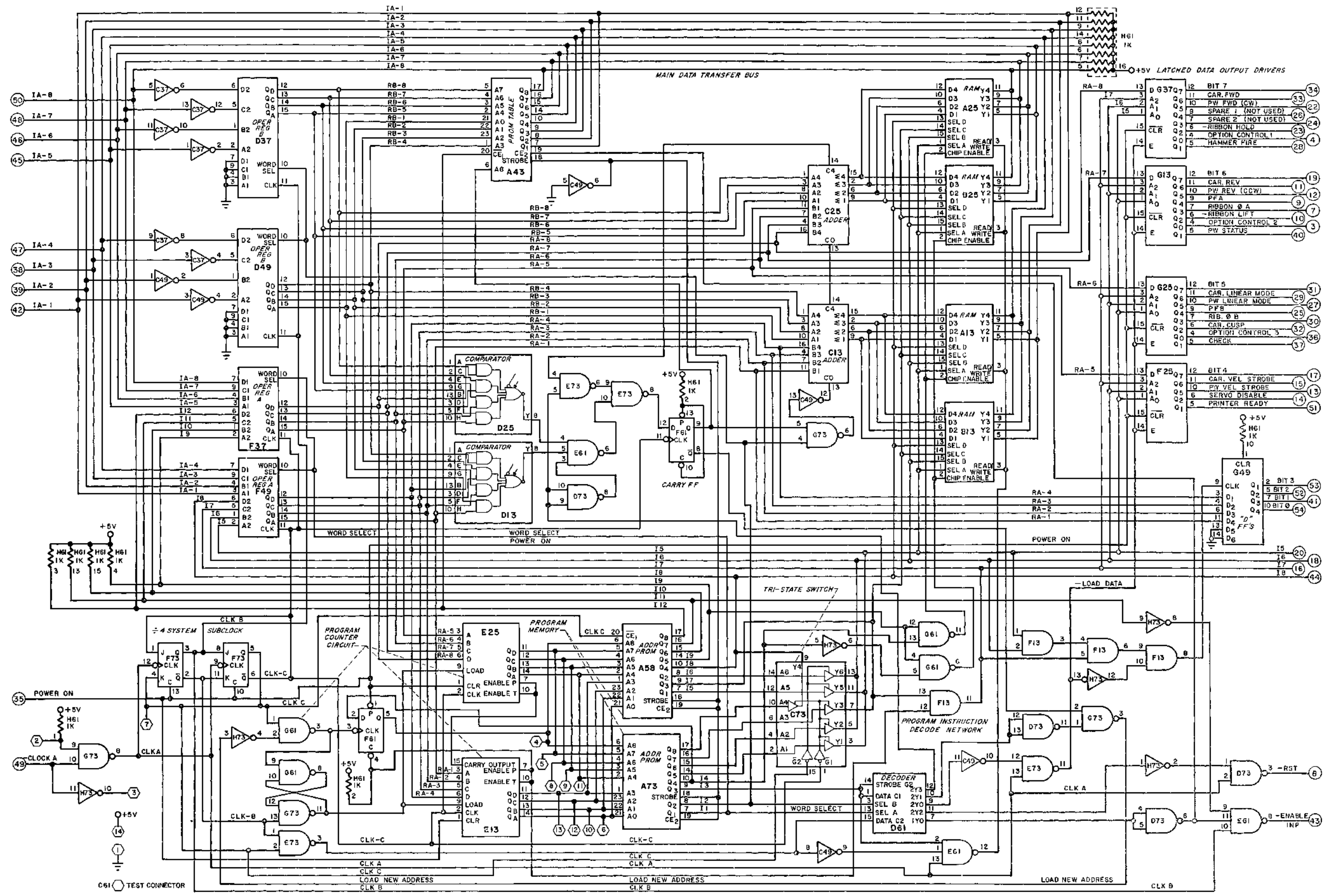

Figure 7-3a
 Logic #2 PCB Assy, Standard
 #40510-XX Rev AJ

Figure 7-3a Logic #2 PCB Assy, Std
 #40510-XX Rev AJ (#40827-03 PCB Assy, less ROM's)

REVISION HISTORY:

REV.	ECO#	ETCH	CONFIGURATION
A	9445	01	B/M, released as #24290. Later ECO #9541 changed it to #40510-01.
B	9628	01	Schematic and Assembly as released. B/M changed to agree.
C	9669	01	Cut traces and add jumpers to revise circuits for standardized PROM usage.
D	9743	02	Allow rework of -02 PCB's for use as -01 PCB's in #40510-01 Assemblies.
E	9859	02	-01 to -02 PROMs with carriage retry and servo disable.
F	9881	02	Change to low power Schottky devices to reduce +5 volt current demand for lower heat dissipation.
G	9951	02	Change A73 from type 74LS107 to type 74107 to avoid marginal TTL load distribution. Change signal from "-DIFF .512" to "SERVO DISABLE".
H	A1003	02	Provide for -31 PROM's, Model 1355WP.
J	A1029	02	Provide for -42 PROM's, 8080 Interface.
K	A1096	02	Change from -42 to -43 PROM's, 8080 Interface, for use with #40644-02 Logic #1 PCB only.
L	A1169	02	Change all PROM's and PCB configurations, to delete carriage retries, add PW detent, and resolve carriage misposition problems.
M	9988	05	Relayout PCB to improve heat dissipation, revise RESET logic, and improve fanout.
N	A1274	06	Revise schematic, layout, and PROM call-out to correct problem of failure to recognize commands.
P	A1247	06	Allow use of -06 PCB etch. Increase RAM address hold time to 20 nsec, eliminate PORT 7 decode race condition, and provide for Table ROM enable only when ROM is to be read.
Q	A1444	06	Enable servo only when PW or carriage command is being executed, and provide interfaced access to all 96 PW positions.
R	A1523	06	Modify ROM print hammer energy table for Model 1355WP.
S	A1501	06	Provide for Model 1355HS.
T	A1578	06	Provide for Model 1345 Spec. K, and for proportional ribbon advance for single strike ribbons.
U	A1622	06	Provide ribbon lift cycle frequency limit of 5 cps.
V	A1841	06	Provide for Model 1345 Spec. E, and correct print hammer energy table for European print wheels.
W	A1879	06	Provide for reduced carriage motor current for Model 1355HS.
X	A1945	06	Change carriage velocity curves for Model 1355HS.
Y	A1977	06	Provide lower maximum carriage velocity for Models 1345A and 1355WP.
Z	A3093	06	Change ribbon advance to 2-step for Model 1355HS "underscore" character only.

AA	A3250	06	Lower hammer energy levels 3 and 4 to improve print wheel life for Model 1355WP.
AB	A3289	06	Change Model 1355WP print wheel look up table to make compatible with Model 1345A "Special Applications" installations.
AC	A3508	06	Modify some hammer energy levels, lower peak carriage velocity, and inhibit hammer fire during retries for Models 1355HS.
AD	A3917	06	Provide for Models 1345A Spec. DS, Spec. E, and Spec. T. Added new hammer energy tables for OCR-B Scandia print wheels.
AE	A3929	06	-26 configuration to -27 for Model 1355HS. Change print wheel release time, ribbon advance, and lower maximum print wheel velocity.
AF	B1059	06	Added -84, -85, and -86 configurations for Model 1355WP - OSD, Spec. E, and Diablo Sort.
AG	B1191	06	Added -90 configuration for 1355WP 96 "Financial".
AH	B1308	06	Rework for ESD modifications.
AH'	B1550	06	Documentation change only.
AJ	B1620	06	Configuration changes -27 to -29, -28 to -30. PROM changes to alleviate HS carriage movement problems.

SOLID STATE COMPONENTS USED:

IC's	7400	D73,E73,G61,G73
	74LS04	C37,C49,H73
	7408	F13
	7410	E61
	7453	D13,D25
	74LS74	F61
	74LS83	C13,C25
	74S289	A13,A25,B13,B25
	74107	F73
	74LS155	D61
	74161	E13,E25
	74LS259	F25,G13,G25,G37
	74298	D37,D49,F37,F49
	74367	C73
	74LS174	G49
	Resistor Pack 1K	H61

Diodes (No components listed)

Transistors (No components listed)

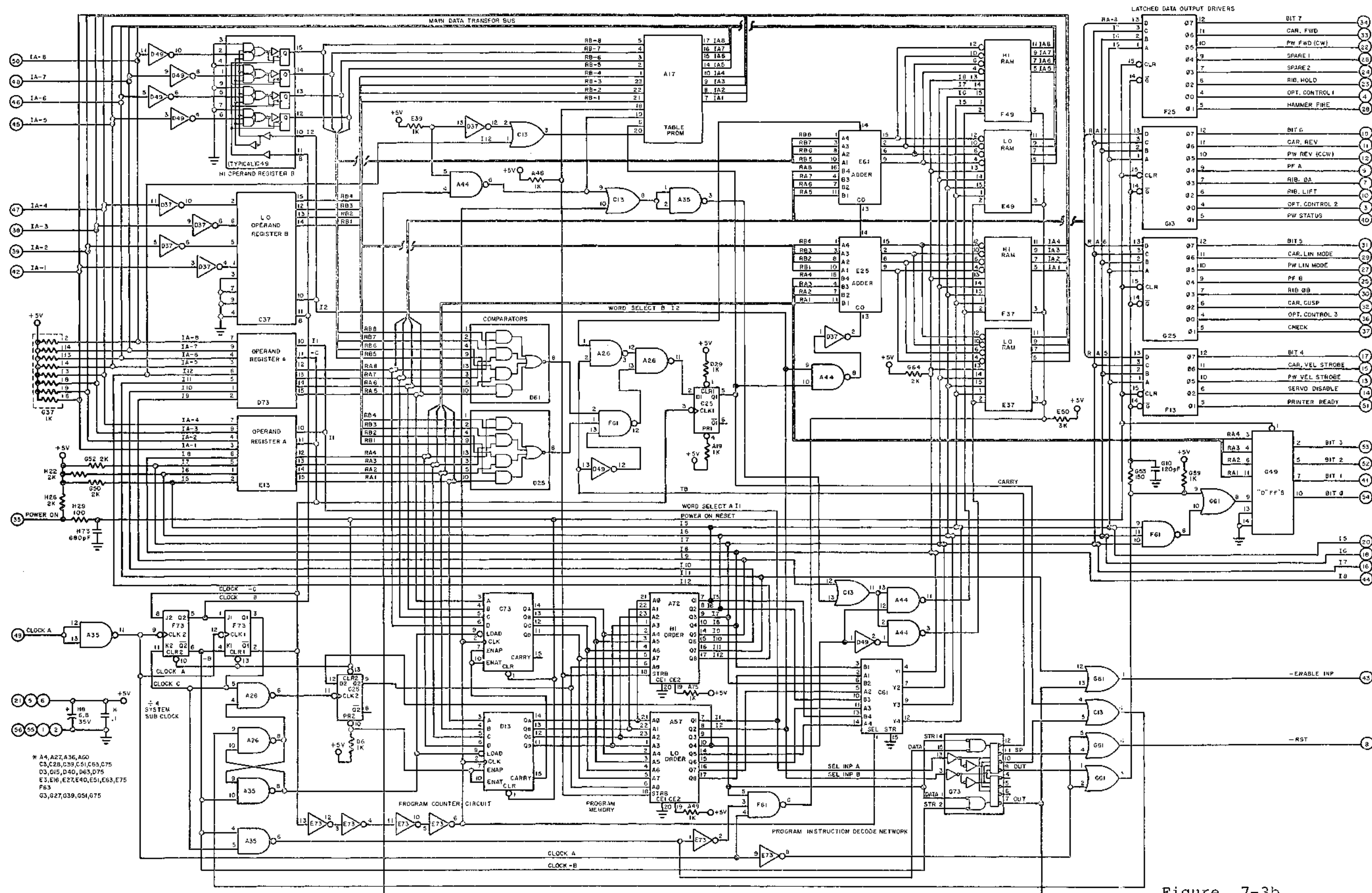

Figure 7-3b
 Logic #2 PCB Assy, Std ESD
 #301850-XX Rev C

Figure 7-3b Logic #2 PCB Assy, Std ESD
#301850-XX Rev C (#40827-05 PCB Assy less PROM's)

REVISION HISTORY:

REV. ECO# ETCH CONFIGURATION

A	B1465	A	As Released
A'	B1550	A	Documentation change only
B	B1574	A	Release -17 (Spec AES) configuration.
C	B1620	A	Change -03 to -18 configuration. PROM changes to alleviate HS carriage movement problems.

SOLID STATE COMPONENTS USED:

IC's	7400	A26, A35, A44
	74LS04	D37, D49, E73
	7410	F61
	7432	C13, G61
	7453	D25, D61
	74LS74	C25
	74LS83	E25, E61
	74107	F73
	74LS155	G73
	74157	C61
	74161	C73, D13
	74LS174	G49
	74LS259	F13, F25, G13, G25
	74LS289	E37, E49, F37, F49
	74298	C37, C49, D73, E13
	Resistor Pack 1K	G37

Diodes (No components listed)

Transistors (No components listed)

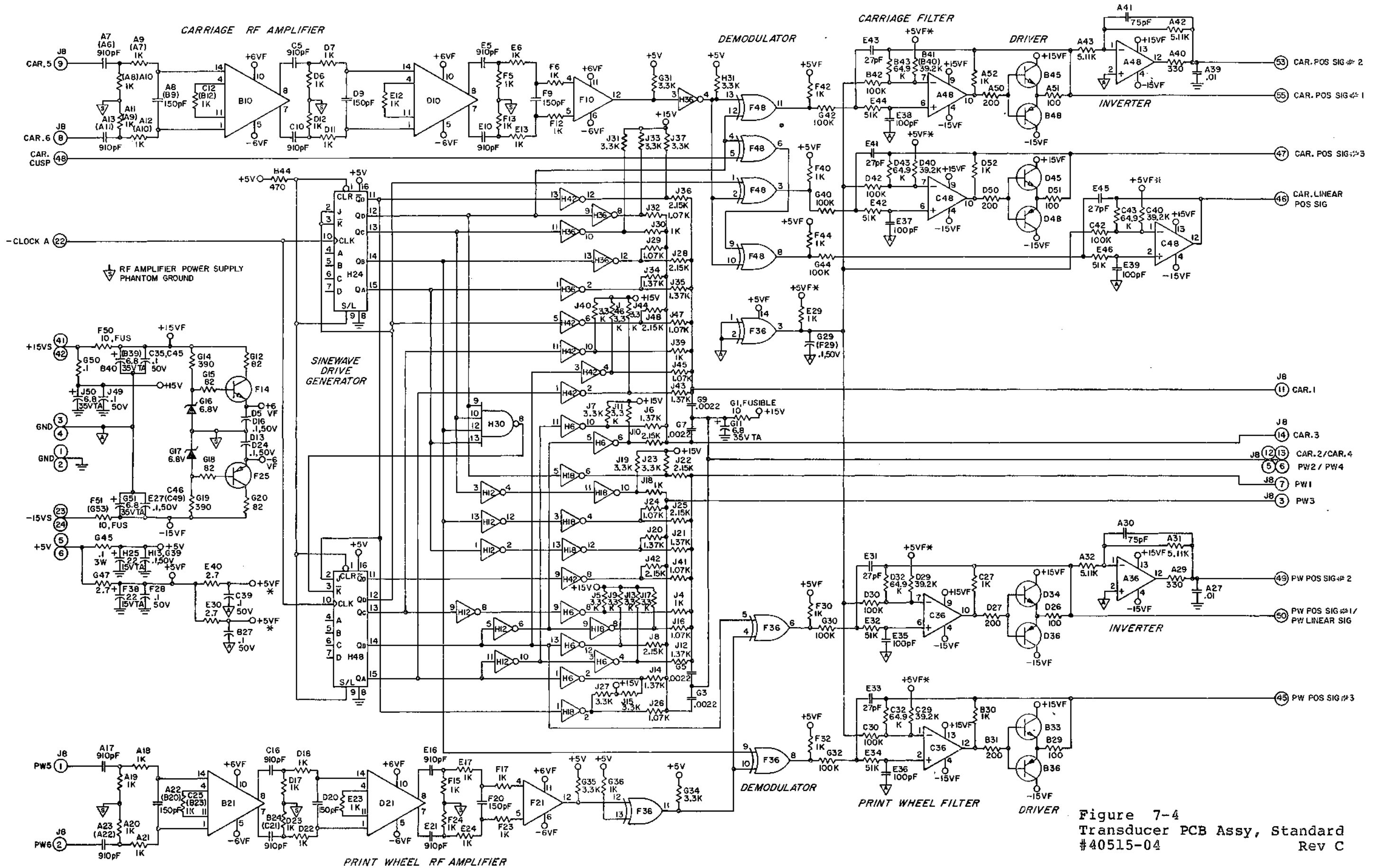

Figure 7-4
 Transducer PCB Assy, Standard
 #40515-04
 Rev C

Figure 7-4 Transducer PCB Assy, Std
 #40515-04 Rev C

REVISION HISTORY:

REV.	ECO#	ETCH	CONFIGURATION
A	9742	01	As released.
B	9830	01	Change resistor G1 from film to composition, and cut "key" pins on connectors J8A and J8B.
A	A1695	02	-XX to -02 configuration. Increase noise immunity by adding .01 uFd filter capacitors and changing resistors A29 and A40 from 100 to 330 Ohm.
A	A1720	03	-02 to -03 configuration. Revise PCB to include Rev A -02 filter capacitors as components A27 and A39. No functional changes.
B	B1163	03	Documentation changes only.
C	B1761	03	Replace connectors J8A and J8B with a single connector J8. Renumber certain pinouts.
A	B1470	03	Release -04 ESD version
B	B1761	03	On -04 Assy's, replace connector J8a and J8B with a single connector J8. Renumber certain pinouts.
C	B2092	04	Release -04 etch. New layout to accommodate auto insertion of components. New locator codes only - no circuit or value changes. Old codes are shown in parentheses.

SOLID STATE COMPONENTS USED:

IC's	Part Number	Location
	7404	H12
	7420	H30
	7406	H6, H18, H36, H42
	74195	H24, H48
	7486 (ICEX)	F36, F48
	72747	A36, A48, C36, C48
	733	B10, B21, D10, D21
	LM319N	F10, F21

Diodes 1N4736A Zener 6.8V G16, G17

Transistors

2N5320	F14
2N5322	F25
2N4401	B33, B45, D34, D45
PN3644	B36, B48, D36, D48

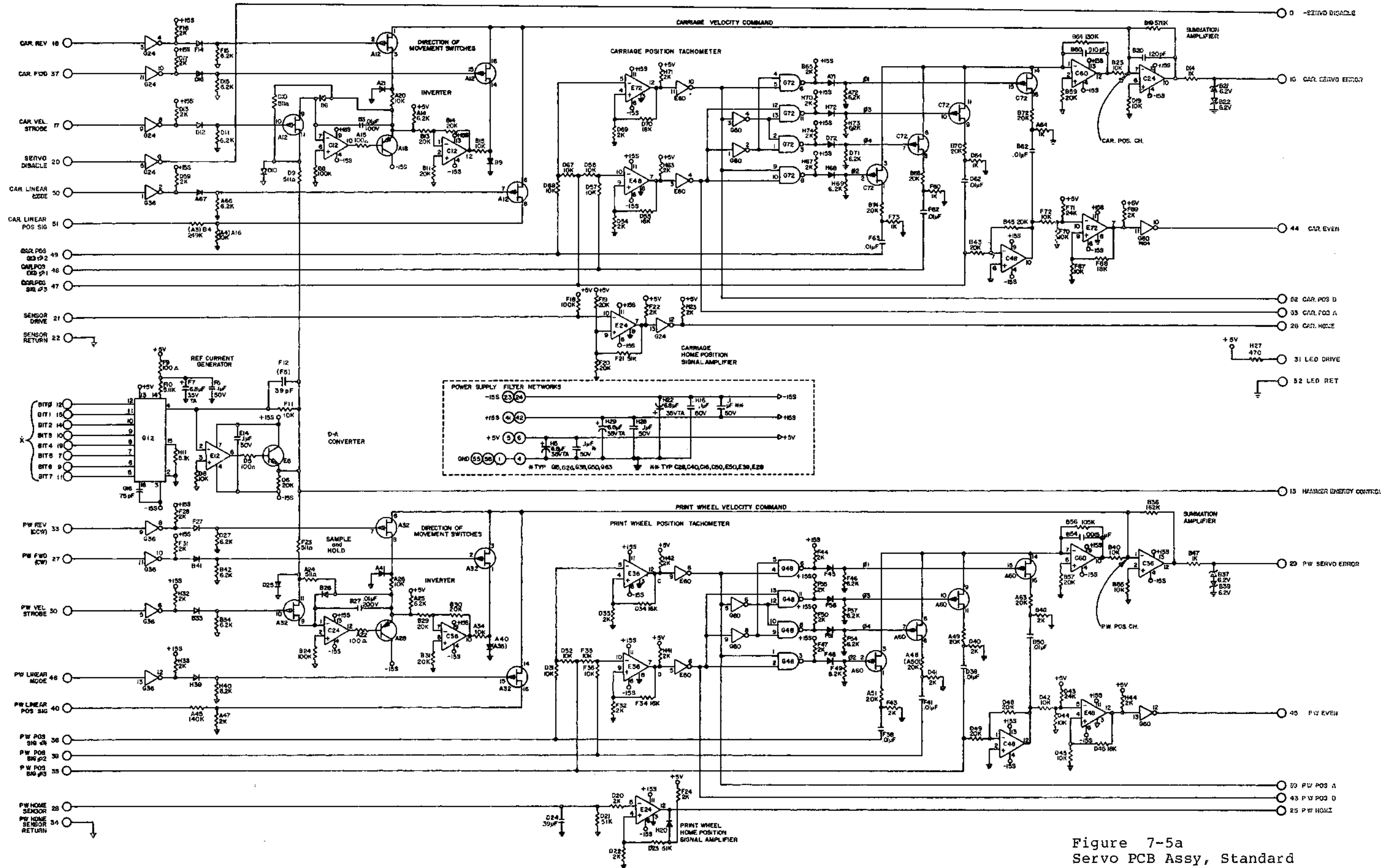

Figure 7-5a
 Servo PCB Assy, Standard
 #40520-04
 Rev P

Figure 7-5a Servo PCB Assy, Std
#40520-04 Rev P

Transistors
2N4401
PN3644

E6
A18,A28

REVISION HISTORY:

REV.	ECO#	ETCH	CONFIGURATION
A	9595	01	As released.
B	9665	02	Update circuit for production.
C	9702	03	Update circuit for production.
D	9737		Allow use of either -02 or -03 PCB etch.
E	9771	03	Add jumper wire from G24-6 to I/O-8, change resistor B36 to 28K Ohm to facilitate servo noise fix.
F	9804	04	Revise PCB to include Rev. E changes. Change signal name from "-DIFF .512" to "SERVO DISABLE". Change component designator B18 to B20.
G	9812	04	Delete connection from G12-1 to ground to improve D/A slew rate.
H	9858	04	Delete capacitor B39 to improve tachometer channel phase margin, and eliminate audible PW servo oscillation.
J	9873	04	Change servo error clamp zener diodes B21, B22, B37, and B38 from 1N5234 to 1M6.2ZS2.
K	9884	04	Change from -01 to -02. Replace resistor D8 with jumper wire to improve servo operation.
L	9947	04	Revise assembly to change F5 to F6, and F11A to F5.
M1	A1337	04	MANDATORY CHANGE. -02 to -03 configuration. Change capacitor B60 to 910 pFd, and capacitors B18, B20, or B22 (depending on etch level) to 750 pFd, to relieve main frame casting resonance.
M2	9923	05	-03 to -04 configuration. Use -05 etch PCB. Improve circuit design to prevent servo burnout in case of component failure, and reduce costs.
N	A1504	05	Engineering documentation change only.
P	B2092	06	Release -06 etch. New layout to accommodate auto insertion of components. New locator codes only - no circuit or value changes. Old codes are shown in parentheses.

SOLID STATE COMPONENTS USED:

IC's	7404	E60,G60	
	7406	G24,G36	
	7426	G48,G72	
	1741	E12	
	747 C	C12,C24,C36,C48	
	8041	A12,A32,A60,C72	
	1408L-6	G12	
	LM319N	E24,E36,E48,E72	
	747 C (low offset)	C60	
	Diodes	1N5234B Zener 6.2V	B21,B22,B37,B38
		1N4454	A21,A40,A41,A67,A71,B6,B9,B26,B33,B41, D10,D12,D16,D25,D72,F14,F27,F45,F48,F51, F56,H20,H39,H68,H72

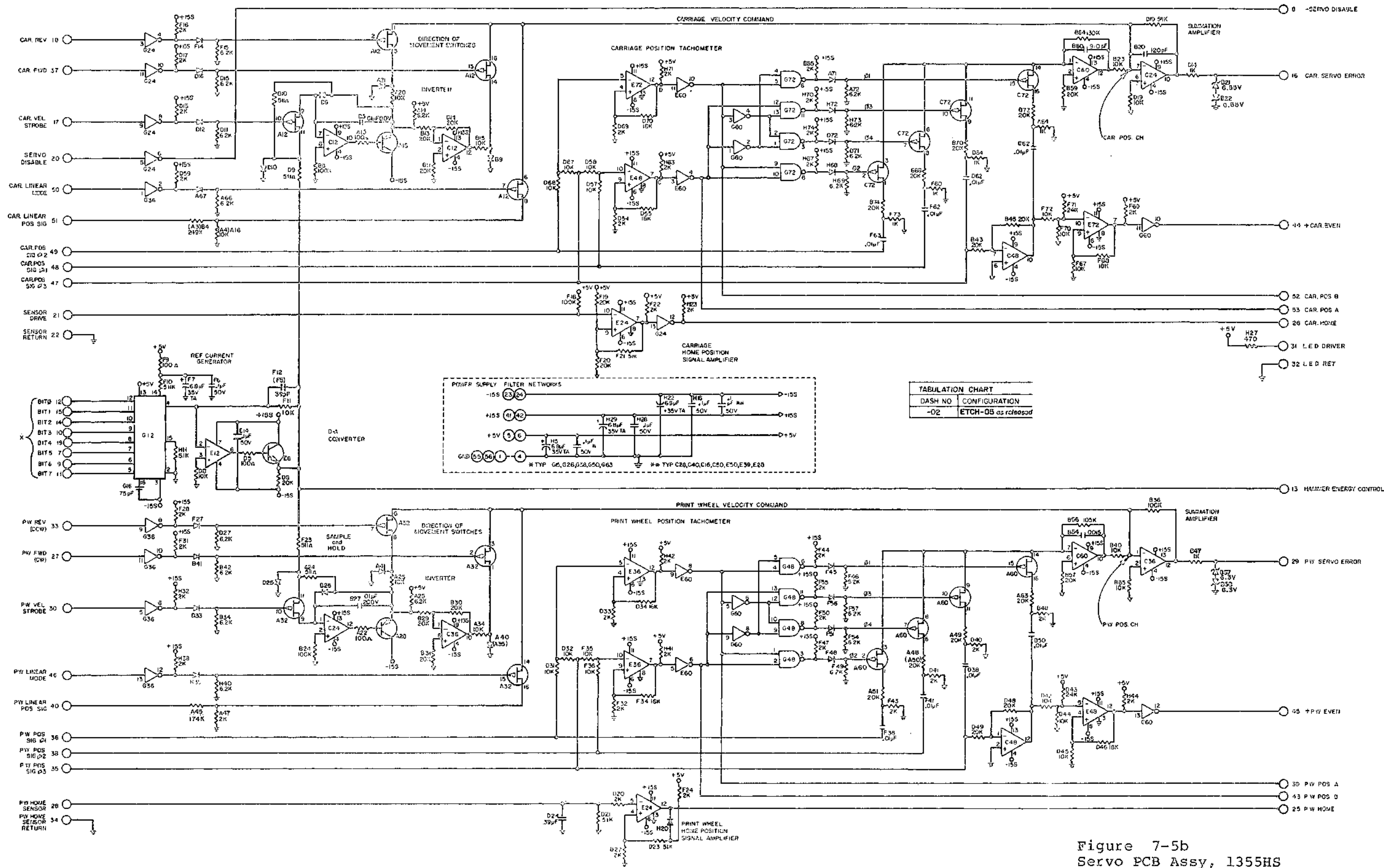

Figure 7-5b
 Servo PCB Assy, 1355HS
 #46020-02 Rev B

Figure 7-5b Servo PCB Assy, 1355HS
#46020-02 Rev B

REVISION HISTORY:

REV. ECO# ETCH CONFIGURATION

A	A1487	05	As released.
A	A1876	05	Change to -02 configuration.
B	B2121	06	Release -06 etch. New layout to accommodate auto insertion of components. New locator codes only - no circuit or value changes. Old codes are shown in parentheses.

SOLID STATE COMPONENTS USED:

IC's	7404	E60,G60
	7406	G24,G36
	7426	G48,G72
	1741	E12
	747 C	C12,C24,C36,C48
	8041	A12,A32,A60,C72
	1408L-6	G12
	LM319N	E24,E36,E48,E72
	747 C (low offset)	C60
Diodes	100023-01 Zener 6.55V	B21,B22
	13211 Zener 6.3V	B37,B38
	1N4454	A21,A40,A41,A67,A71,B6,B9,B26,B33,B41, D10,D12,D16,D25,D72,F14,F27,F45,F48, F51,F56,H20,H39,H68,H72
Transistors		
	2N4401	E6
	PN3644	A18,A28

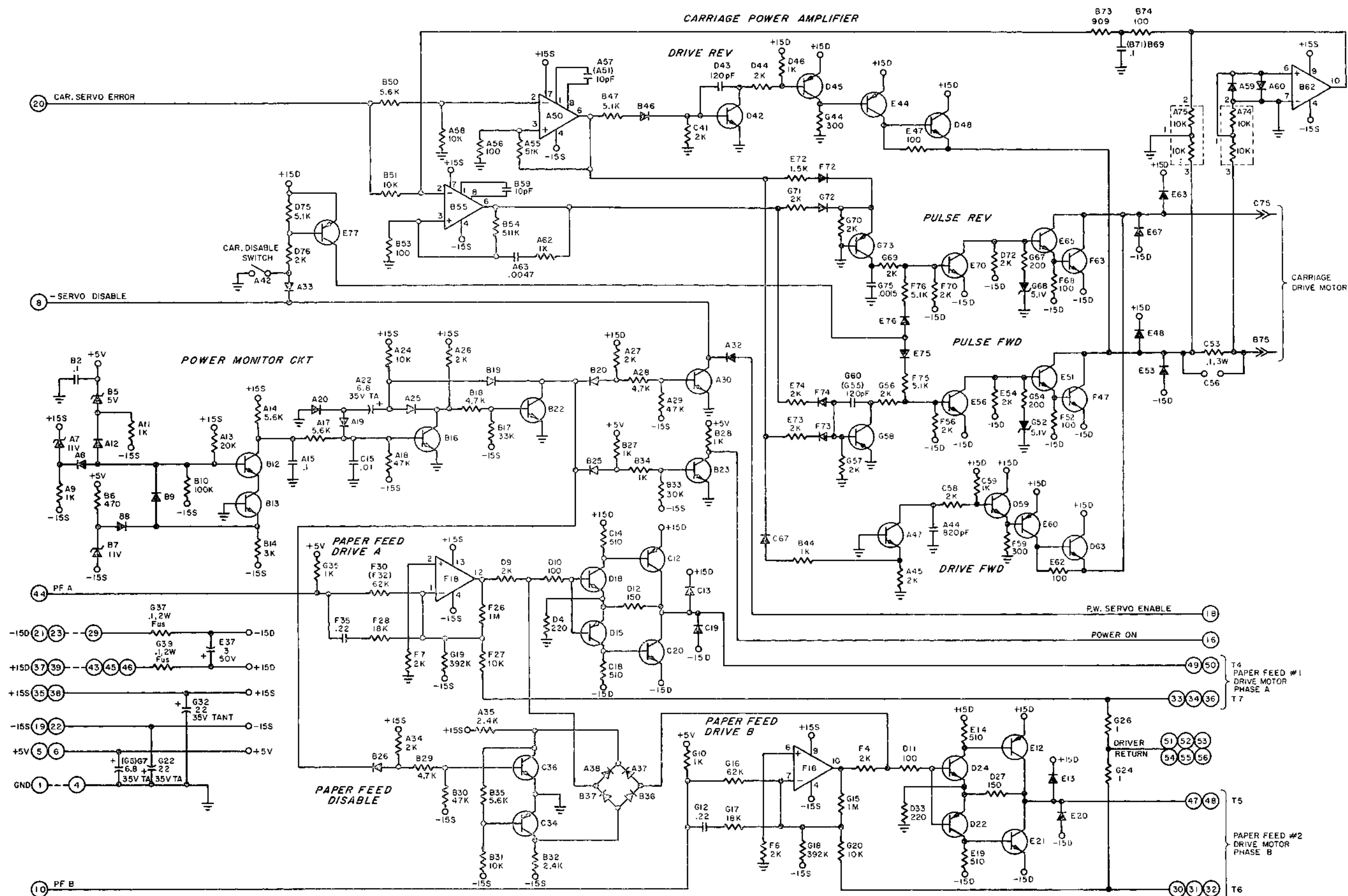

Figure 7-6a
 Car. Power Amp PCB Assy, Standard
 #40525-10
 Rev C

Figure 7-6a Carriage Power Amplifier PCB Assy, Std
#40525-10 Rev C

REVISION HISTORY:

REV.	ECO#	ETCH	CONFIGURATION
A	9536	--	B/M as released.
B	9647	01	Schematic, Assembly, and B/M as released.
C	9658	02	Incorporate changes to solve current instrumentation noise problems.
D	9729	03	Allow use of -03 etch PCB.
E	9772	03	Incorporate changes to facilitate servo noise fix, and provide improved paper feed noise immunity.
F	9803	04	Allow use of -04 etch PCB incorporating Rev. E changes.
G	9816	04	Add resistor F54 to eliminate current spike during power up.
H	9839	04	Allow use of #24376-01 Heat Sink.
J	9862	05	Revise PCB artwork to include Rev. G and H changes, and to simplify circuits; Assembly is -02.
H1	9900	05	Add connection from A32 to I/O pin 8.
K	9970	05	Documentation change only to correct drawing error.
L	A1088	05	Change component designator B3 to B5. Change resistors G54 and G67 from 300 to 200 Ohm 1W, change resistors G44 and F59 to 5%, and correct documentation errors.
M	A1124	05	Change resistor D76 from 5.1K to 2K Ohm, to allow power up sequencing when using power supplies with a low current foldback. Change -01 Rev. H1 to -03 Rev. H2. -02 to -04 configuration.
N	A1260	05	-04 to -05 configuration. Label G52 and G68 5.1V. Remove -5.1V line from junction of G52 and G54. Change the following resistor values: B33 from 75K to 15K Ohm F32 from 82K to 62K Ohm G16 from 82K to 62K Ohm G18 from 523K to 392K Ohm G19 from 523K to 392K Ohm C56 from 2K to 1K Ohm
P	A1260A	05	Correct documentation error. No schematic or assembly change.
Q	A1565	05	Correct documentation error. No schematic or assembly change.
A	A3128	07	-05 to -06 configuration. Allow use of -07 etch. PCB re-layout only. Change locator codes as follows: C57 to A44 C54 to B46 C55 to B47 C56 to B44 D54 to A45 D56 to A47
A	A3278	07	-05 to -07 configuration, -06 to -08 configuration. Reduce sensitivity to power supply variations. Remove D74. Replace D73 with jumper. Change zeners A7 and B7 to 11 volt devices. Change D75 to 5.1K, B33 to 30K.
B	A3754	07	Hardware change only. (Heatsink mounting screws.)
C	A3966	07	Documentation change only (-08 only).

D	B1613	07	Replace resistor pack A70 with 2 resistor packs at A70.
A	B1308	07	Release -09 configuration as ESD version.
B	B1422	07	Add ESD insulator.
A	B1325	08	Release -08 etch as -10 configuration. Add capacitors A51 and B59 at Op Amps A50 and B55. Replace resistor pack A70 with 2 resistor packs A74 and A75.
B	B1615	08	Documentation change only.
C	B2152	09	Release -09 etch. New layout to accommodate auto insertion of components. New locator codes only - no circuit or value changes. Old codes are shown in parentheses.

SOLID STATE COMPONENTS USED:

IC's	747 C	B62, F18
	748	A50, B55
	Resistor Pack 10K	A74, A75
Diodes	1N4733	Zener 5V B5
	100138-01	Zener 11V A7, B7
	1N5231B	Zener 5.1V G52, G68
	1N4454	A8, A12, A19, A20, A25, A32, A33, A37, A38, A59, A60, B8, B9, B19, B20, B25, B26, B36, B37, B46, C67, E75, E76, F72, F73, F74, G72
	1N4002	C13, C19, E13, E20
	1N5807	E48, E63
	1N5415	E53, E67
Transistors	PN3644	C34, D15, D22, D45, D59, E77, G58, G73
	2N4401	A30, B12, B13, B16, B22, B23, C36, D18, D24, D42, A47, E56, E70
	2N5320	E51, E65
	2N5322	E44, E60
	2N6103	D48, D63, F47, F63
	TIP41A	C20, E21
	TIP42A	C12, E12

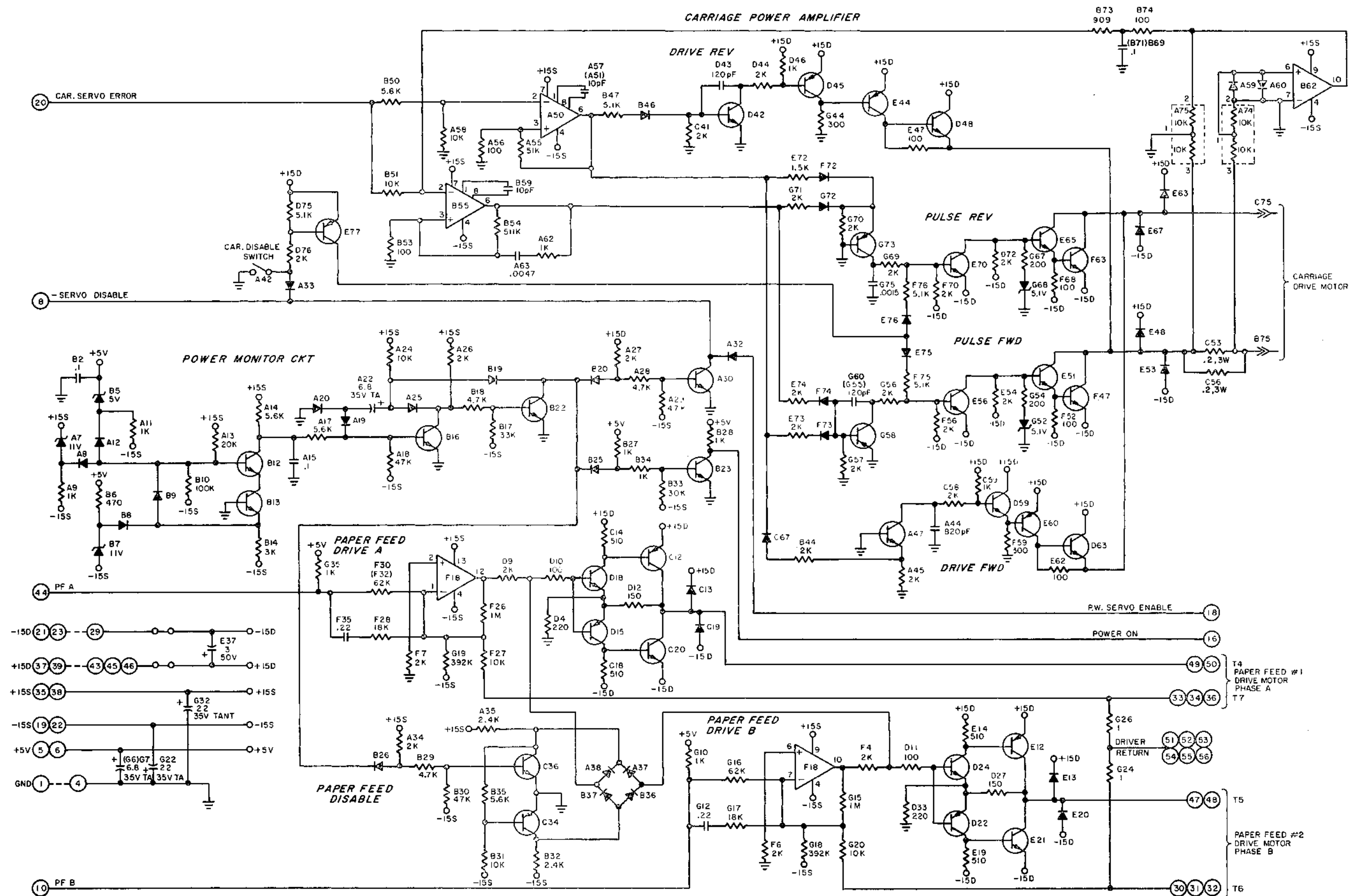

Figure 7-6b
 Car. Power Amp PCB Assy, 1355HS
 #46025-05 Rev C

Figure 7-6b Carriage Power Amplifier PCB Assy, 1355HS
 #46025-05 Rev C

REVISION HISTORY:

REV.	ECO#	ETCH	CONFIGURATION
A	A1503	05	As released.
B	A1898	05	Raise resistor C53 off PCB for heat dissipation.
A	A3128	07	-01 to -02 configuration. Allow use of -07 etch. Place resistor C53 in parallel with resistor C56, both .2 Ohm 3W. Change component locator codes as follows: C57 to A44 C56 to B44 C55 to B47 C54 to B46 D54 to A45 D56 to A47
A	A3278	07	-02 to -03 configuration. Change zener diodes A7 and B7 to 11 volt devices. Remove D74. Replace D73 with a jumper. Change resistor D75 to 5.1K and B33 to 30K.
B	A3696	07	Documentation change only.
C	A3754	07	Hardware change only, heatsink mounting screws.
D	A3966	07	Documentation change only.
A	B1308	07	Release -04 configuration as ESD version
B	B1422	07	Add ESD insulator.
A	B1325	08	Release -08 etch as -05 configuration. New layout to incorporate -04 changes, and add capacitor B59 at Op Amp B55.
B	B1615	08	Documentation change only.
C	B2152	09	Release -09 etch. New layout to accommodate auto insertion of components. New locator codes only - no circuit or value changes. Old codes are shown in parentheses.

SOLID STATE COMPONENTS USED:

IC's	747 C	B62,F18
	748	A50,B55
	Resistor Pack 10K	A70
Diodes	1N4733 Zener 5V	B5
	100138-01 Zener 11V	A7,B7
	1N5231B Zener 5.1V	G52,G68
	1N4454	A8,A12,A19,A20,A25,A32,A33,A37,A38, A59,A60,B8,B9,B19,B20,B25,B26,B36,B37, B46,C67,E75,E76,F72,F73,F74,G72
	1N4002	C13,C19,E13,E20
	1N5807	E48,E63
	1N5415	E53,E67

Transistors

PN3644	C34,D15,D22,D45,D59,E77,G58,G73
2N4401	A30,A47,B12,B13,B16,B22,B23,C36,D18,D24, D42,E56,E70
2N5320	E51,E65
2N5322	E44,E60
2N6103	D48,D63,F47,F63
TIP41A	C20,E21
TIP42A	C12,E12

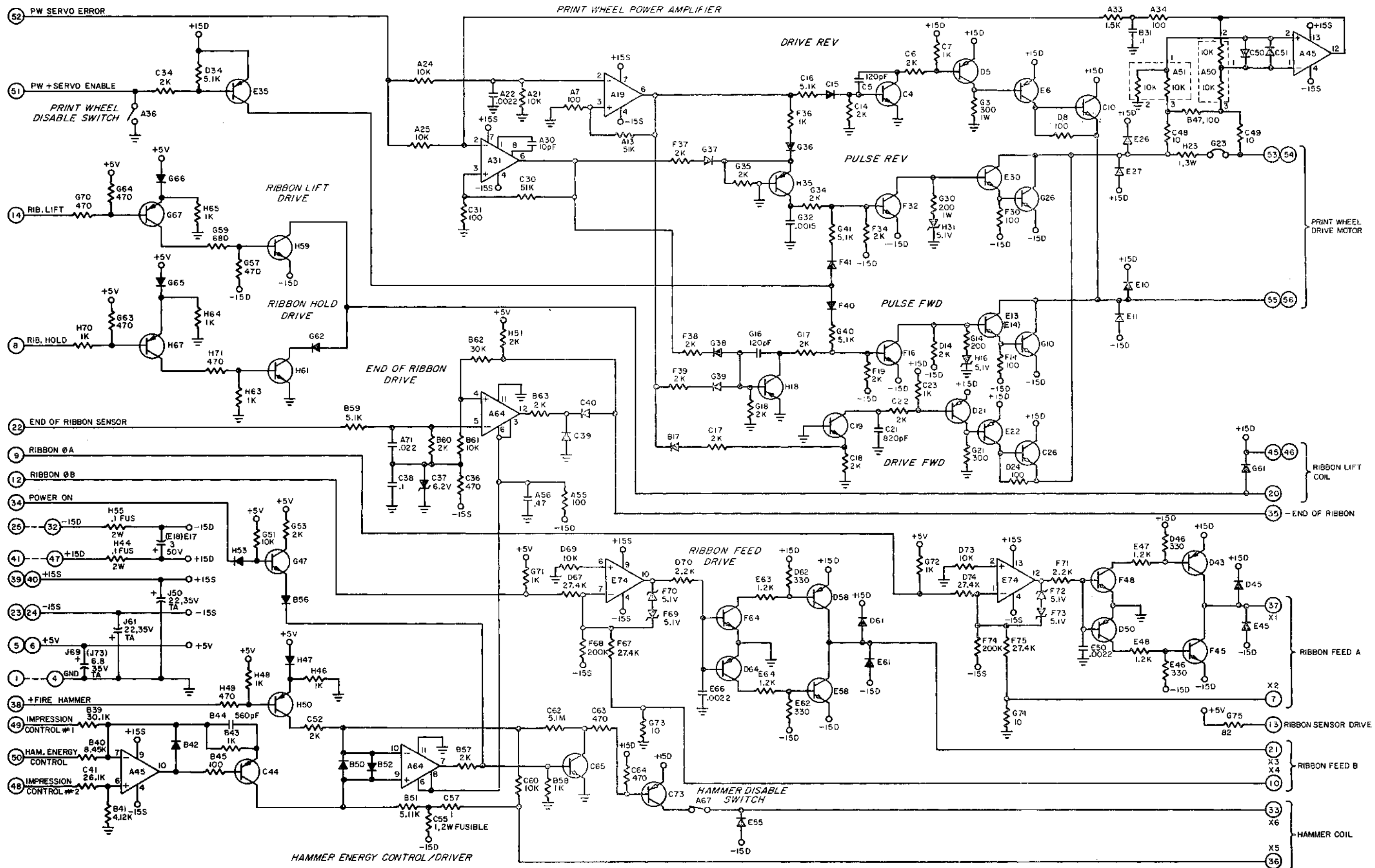

Figure 7-7a
P W Power Amp PCB Assy, Standard
#40530-10
Rev B

Figure 7-7a Print Wheel Power Amplifier PCB Assy, Std
#40530-10 Rev B

REVISION HISTORY:

REV.	ECO#	ETCH	CONFIGURATION
A	9544	01	B/M as released.
B	9587	01	Schematic and Assembly as released. Revised B/M.
C	9635	02	Incorporate new circuits for acoustic noise elimination.
D	9648	02	Correct drawing error. Change component designators A26 to C31, and A27 to C30.
E	9697	02	Change capacitors C68 and C75 from .22 to 1 uFd, to increase ribbon motor drive.
F	9738	03	Allow use of 40531-03 etch PCB for -01 Assembly, and to change transistor type.
G	9773	03	Delete components A9, A10, A26, and A27, to facilitate servo noise fix.
H	9791	03	MANDATORY CHANGE. Change resistor A33 from 2K to 1.5K Ohm to decrease PW motor temperature rise.
J	9817	03	Add resistor F17 to eliminate current spike during power up.
K	9829	03	Add a resistor across diode B58, to eliminate unwanted hammer fire during power down.
L	9838	03	Allow use of #24376-02 Heat Sink.
L1	A1123	03	Change resistor C34 from 5.1K to 2K Ohm to allow power up sequencing when using power supplies with a low current foldback. Change -01 to -03; -02 to -04.
L2	A1230	06	Delete components C68, D68, D72, D75, E75, and F66, and change resistors F67 and F75 from 10K to 27.4K Ohm to correct ribbon drive problems. Add -05 to Tab.
M	A1030	06	Allow use of -06 etch PCB for -02 Assembly.
N	A1050	06	Change zener diode C37 from 6.8V 1/2W to 6.2V 1W.
P	A1123	06	(see above)
Q	A1230	06	(see above), also -XX to -06 configuration.
R	A1413	06	-06 to -07 configuration. Delete filter capacitors B48 and B49 to alleviate retries.
A	A3278	06	-07 to -08 configuration. Remove diode C33. Replace D33 with a jumper. Change D34 to 5.1K.
B	A3754	06	Mechanical change only. (Heatsink mounting screws.)
C	A3966	06	Documentation change only.
D	B1613	06	Replace resistor pack A53 with 2 packs at A53.
A	B1308	06	-08 to -09 configuration as ESD version.
B	B1422	06	Add ESD insulator.
A	B1325	08	Release -08 etch as -10 configuration. New layout to incorporate -09 changes. Replace resistor packs at A53 with packs at A50 and A51. Add capacitor A30 at Op Amp A31.
B	B2152	09	Release -09 etch. New layout to accommodate auto insertion of components. New locator codes only - no circuit or value changes. Old codes are shown in parentheses.

SOLID STATE COMPONENTS USED:

IC's	747 C	A45, E74
	748	A19, A31
	LM319N	A64
	Resistor Pack 10K	A50, A51
Diodes	1N4454	B17, B42, B50, B52, B56, C15, C39, C40, C50, C51, F40, F41, G36, G37, G38, G39, G65, G66, H47, H53
	1N4002	D45, D61, E45, E55, E61, G61, G62
	1N5231B Zener 5.1V	F69, F70, F72, F73, H16, H31
	1N5415	E10, E11, E26, E27
	1M6.2ZS2 Zener 6.2V	C37
Transistors	PN3644	C44, D5, D21, D43, D50, D58, D64, E35, G67, H18, H35, H50, H67
	2N4401	C4, C19, C65, E58, F16, F32, F45, F48, F64, G47, H61
	2N5322	E6, E22
	2N5320	E13, E30, H59
	2N6103	C10, C26, G10, G26
	TIP125	C73

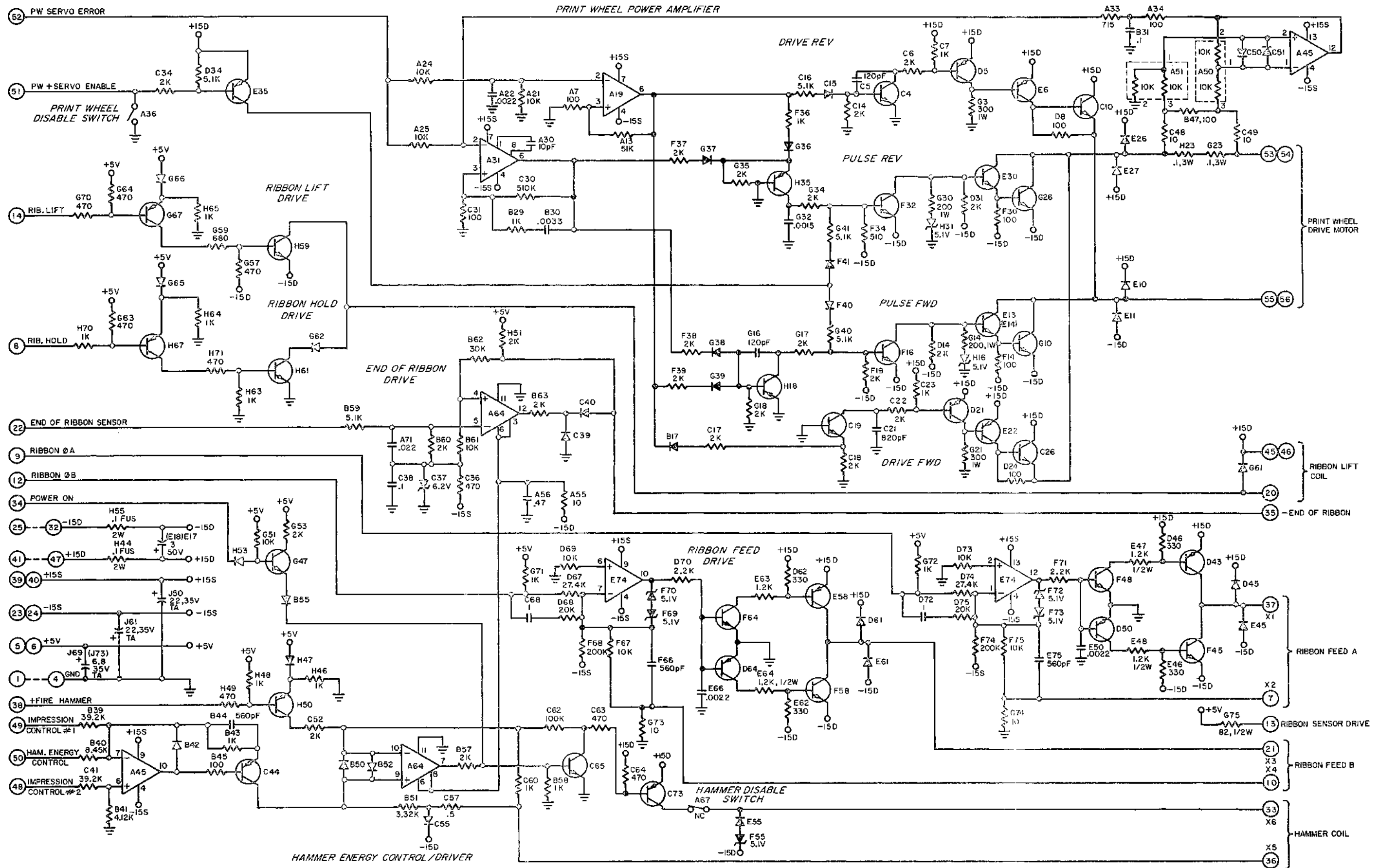

Figure 7-7b
 P W Power Amp PCB Assy, 1355
 #40730-10 Rev B

Figure 7-7b Print Wheel Power Amplifier PCB Assy, 1355
 #40730-10 Rev B

Transistors

PN3644
 2N4401
 2N5322
 2N5320
 2N6103
 TIP125

C44,D5,D21,D43,D50,D64,E35,E58,G67,H18,
 H35,H50,H67
 C4,C19,C65,F16,F32,F45,F48,F58,F64,G47,
 H61
 E6,E22
 E13,E30,H59
 C10,C26,G10,G26
 C73

REVISION HISTORY:

REV. ECO# ETCH CONFIGURATION

A 9982 01 As released.
 A1 A1125 01 Change -01 to -03.
 B 9987 02 -XX to -02 configuration. Allow use of -02 etch PCB.
 C A1125 02 -02 to -04 configuration. Change resistor C34 from 5.1K to 2K Ohm, to allow power up sequencing when using power supplies with a low current foldback.
 D A1413 02 -04 to -05 configuration. Remove filter capacitors B48 and B49 to alleviate retries.
 A A3128 03 -05 to -06 configuration. Allow use of -03 etch. Add .0033 uFd capacitor B30 and 1K resistor B29 in series between A31-3 and A31-6 parallel to resistor C30 (resistor B30 to pin 6).. Change C30 to 510K. Change F34 to 510 Ohm.
 A A3278 03 -05 to -07 configuration, -06 to -08 configuration. Remove diode C33. Replace resistor D33 with a jumper. Change D34 to 5.1K.
 B A3754 03 Mechanical change only, heatsink mounting screws.
 C A3966 03 Documentation change only.
 D B1613 03 Replace resistor pack A53 with 2 packs at A53.
 A B1308 03 -08 to -09 configuration as ESD version.
 B B1422 03 Add ESD insulator.
 A B1325 04 Release -04 etch as -10 configuration. New layout to incorporate -09 changes. Replace resistor packs at A53 with packs at A50 and A51. Add capacitor A30 at Op Amp A31.
 B B2152 05 Release -05 etch. New layout to accommodate auto insertion of components. New locator codes only - no circuit or value changes. Old codes are shown in parentheses.

SOLID STATE COMPONENTS USED:

IC's 747 C A45,E74
 748 A19,A31
 LM319N A64
 Resistor Pack 10K A50, A51

Diodes 1N4454 B17,B42,B50,B52,B55,C15,C39,C40,C50,C51,
 F40,F41,G36,G37,G38,G39,G65,G66,H47,H53
 1N4002 C55,D45,D61,E45,E55,E61,G61,G62
 1N5231B Zener 5.1V F69,F70,F72,F73,H16,H31
 1N5415 E10,E11,E26,E27
 1N5234B Zener 6.2V C37
 1N5338A Zener 5.1V F55

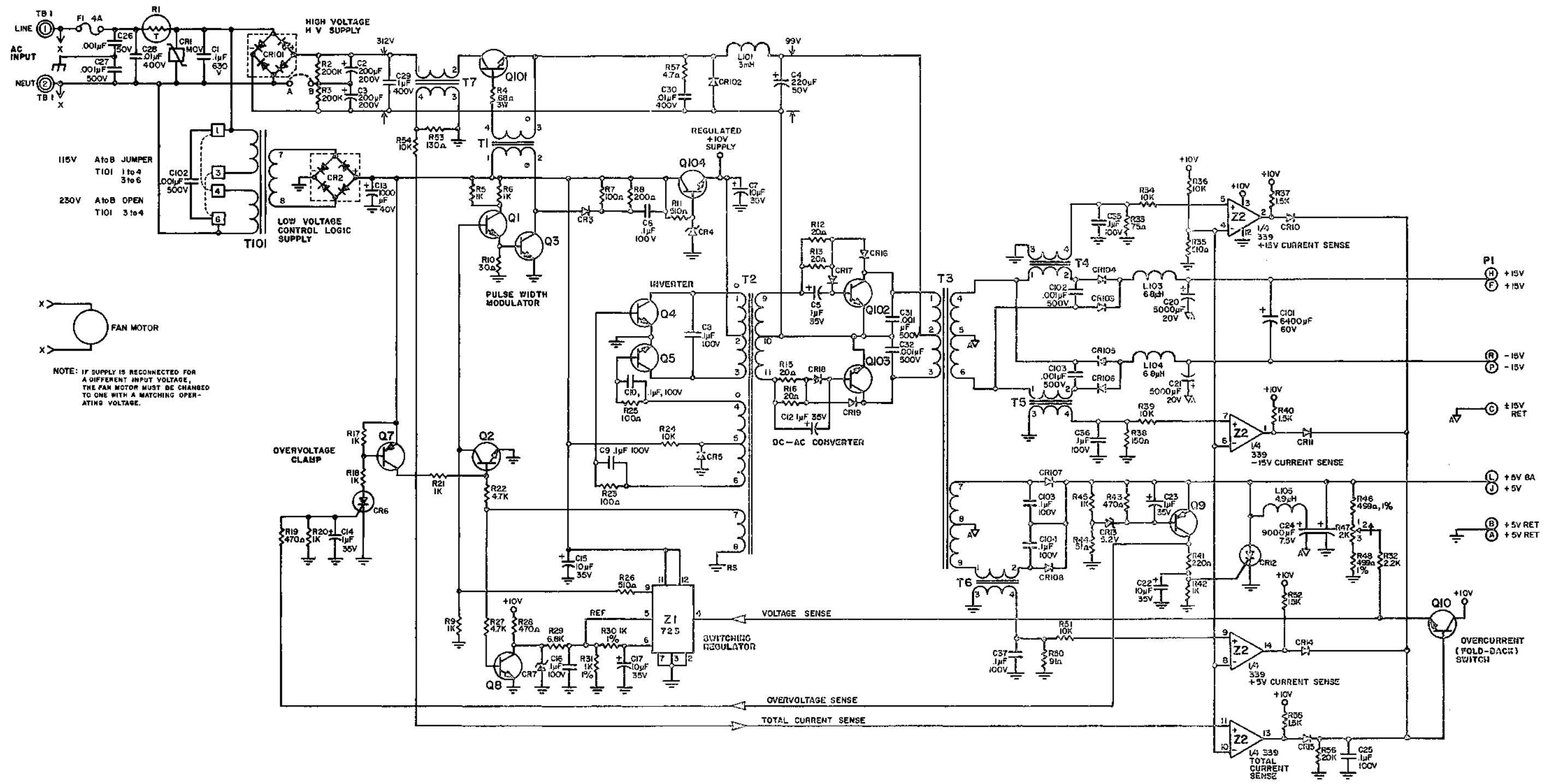

Figure 7-8a
Internal Pwr Sup Assy Option, DP
#24250-XX
Rev C

Figure 7-8a Internal Power Supply Assy Option, DP
#24250-XX Rev C

REVISION HISTORY:

REV. ECO# ETCH CONFIGURATION

A A1174 (NA) As released.
B A1442 (NA) Update documentation for -01/-51, and add -02/-52 configurations.
C A1551 (NA) Change placement of Serial Number label. No functional or documentation changes.

SOLID STATE COMPONENTS USED:

IC's	723CP	Z1
	LM339N	Z2
Diodes	A20A	CR1
	C106F2 (SCR)	CR6
	SD41	CR107,CR108
	VJ448 (Bridge)	CR101
	WO4 (Bridge)	CR2
	1N751B Zener	CR13
	1N753A Zener	CR7
	1N914	CR5,CR10,CR11,CR14,CR15
	1N961B Zener	CR4
	1N3893	CR102
	1N3889	CR103,CR104,CR105,CR106
	1N4933	CR3,CR17,CR18
	1N4936	CR16,CR19
	2N6400 (SCR)	CR12
Transistors		
	2N6308	Q101,Q102,Q103
	TIP-29	Q3,Q104
	2N1711	Q4,Q5
	2N3904	Q1,Q2,Q8,Q10
	2N3906	Q7,Q9

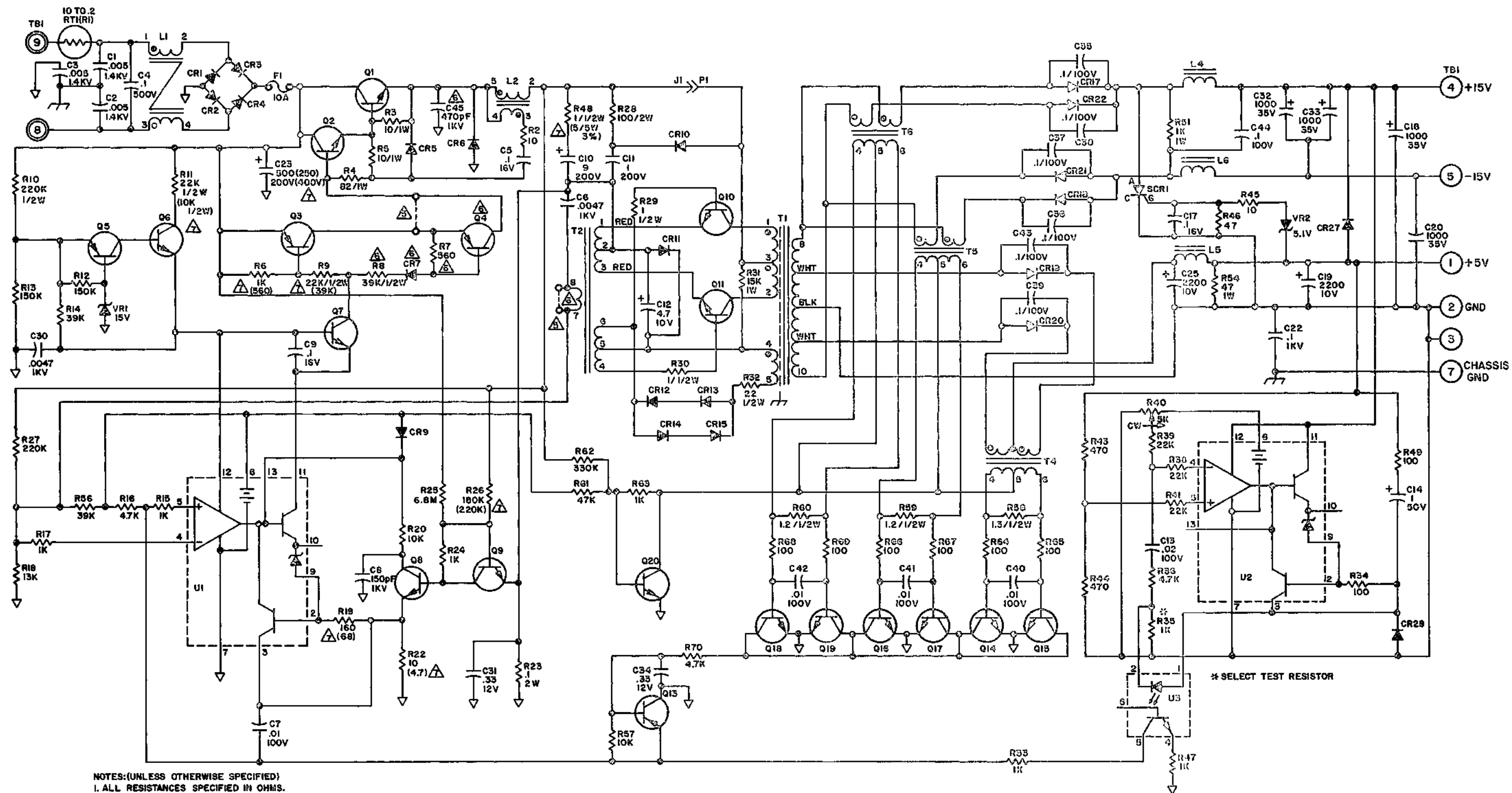

- NOTES: (UNLESS OTHERWISE SPECIFIED)
1. ALL RESISTANCES SPECIFIED IN OHMS.
 2. ALL RESISTORS ARE 1/4 WATT, ±5%.
 3. ALL CAPACITANCE SPECIFIED IN MICROFARADS.
 4. ⚡ DENOTES PRIMARY CIRCUIT COMMON RETURN.
- ⚡ INSTALL JUMPER FOR 115V(-01) OPERATION ONLY.
- ⚡ INSTALL COMPONENTS FOR 220V(-02) OPERATION ONLY.
- ⚡ USE COMPONENT VALUES IN PARENTHESES FOR 220V(-02) OPERATION ONLY.

Figure 7-8b
 Internal Pwr Sup Assy Option, B
 #26021-XX
 Rev D

Figure 7-8b Internal Power Supply Assy Option, B
 #26021-XX Rev D

REVISION HISTORY:

REV.	ECO#	ETCH	CONFIGURATION
A	7472	(NA)	As released
B	7504	(NA)	Diablo Part Number Specification
C	7587	(NA)	Diablo Labeling Specification
C1	7631	(NA)	Release schematics and assembly drawings
C2	7700	(NA)	Correct drawing errors
C3	7758	(NA)	Correct drawing errors
C4	7899	(NA)	Update drawings
D	A4251	(NA)	Update drawings

SOLID STATE COMPONENTS USED:

IC's	723C	A1,A2
	MTC-2E	A3
Diodes	C122F-1	SCR1
	MR502 (115V)	CR1,CR2,CR3,CR4
	MR504 (230V)	CR1,CR2,CR3,CR4
	MR820	CR17,CR18,CR21,CR22
	MR852 (115V)	CR6
	MR824 (230V)	CR6
	S1F2 (115V)	CR7,CR10
	S1F2 (230V)	CR7
	SR3142	CR19,CR20
	1N965 Zener 15V	CR8 (VR1)
	1N4001	CR11,CR27
	1N4148	CR5,CR9,CR12,CR13,CR14,CR15,CR28
	1N751 Zener 5.1V	VR2
Transistors	MPS-U60	Q3,Q4
	MPS-5172	Q8,Q9,Q14,Q15,Q16,Q17,Q18,Q19,Q20
	SJ7280 (matched pair)	Q10/Q11
	SJ7280 (115V)	Q1
	2N6545 (230V)	Q1
	TIP-47 (115V)	Q2
	TIP-49 (230V)	Q2,Q6
	MPSA43 (115V)	Q6,Q7
	2N3439 (230V)	Q7
	2N4126	Q5,Q13

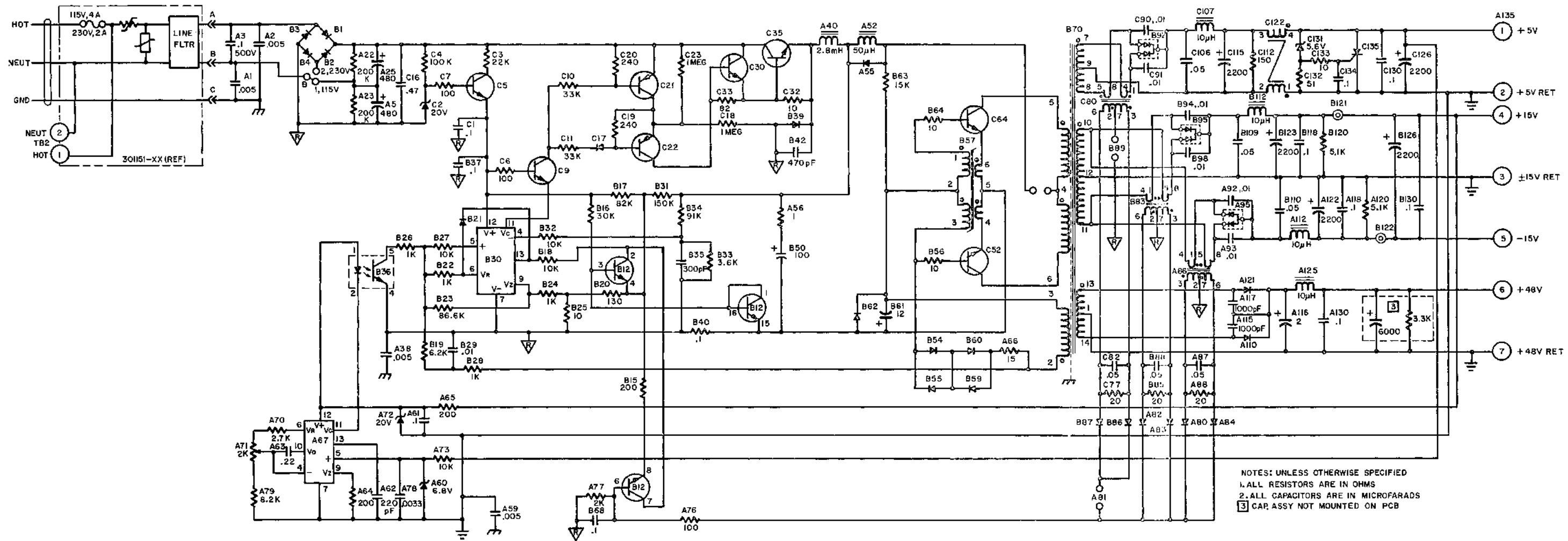

Figure 7-8c
 Internal Pwr Sup Assy Option, U
 #301155-XX Rev C

Figure 7-8c Internal Power Supply Assy Option, U
#301155-XX Rev C

REVISION HISTORY:

REV. ECO# ETCH CONFIGURATION

A B1179 (NA) As released.
B B1312 (NA) New PCB layout and other changes for VDE approval.
C B1683 (NA) Documentation changes only.

SOLID STATE COMPONENTS USED:

IC's	723	A67, B30
	TIL-116	B36
Diodes	MR506	B1, B2, B3, B4
	MR822	A110, A121
	MR854	A55, B39
	100098-01 Zener 20V	A72, C2
	100099-01 Zener 5.6V	C131
	R711XA	A95
	R711X	B95
	3020T	B92
	10329 Zener 6.8V	A60
	1N4454	A80, A82, A83, A84, B21, B54, B55, B59, B60, B62, B86, B87
	1N4936	C17
Transistors	MPSA93	C21, C22
	100106-01	B12
	TIP49	C5, C9, C30
	2N6308	C35, C52, C64
	2N6401	C135

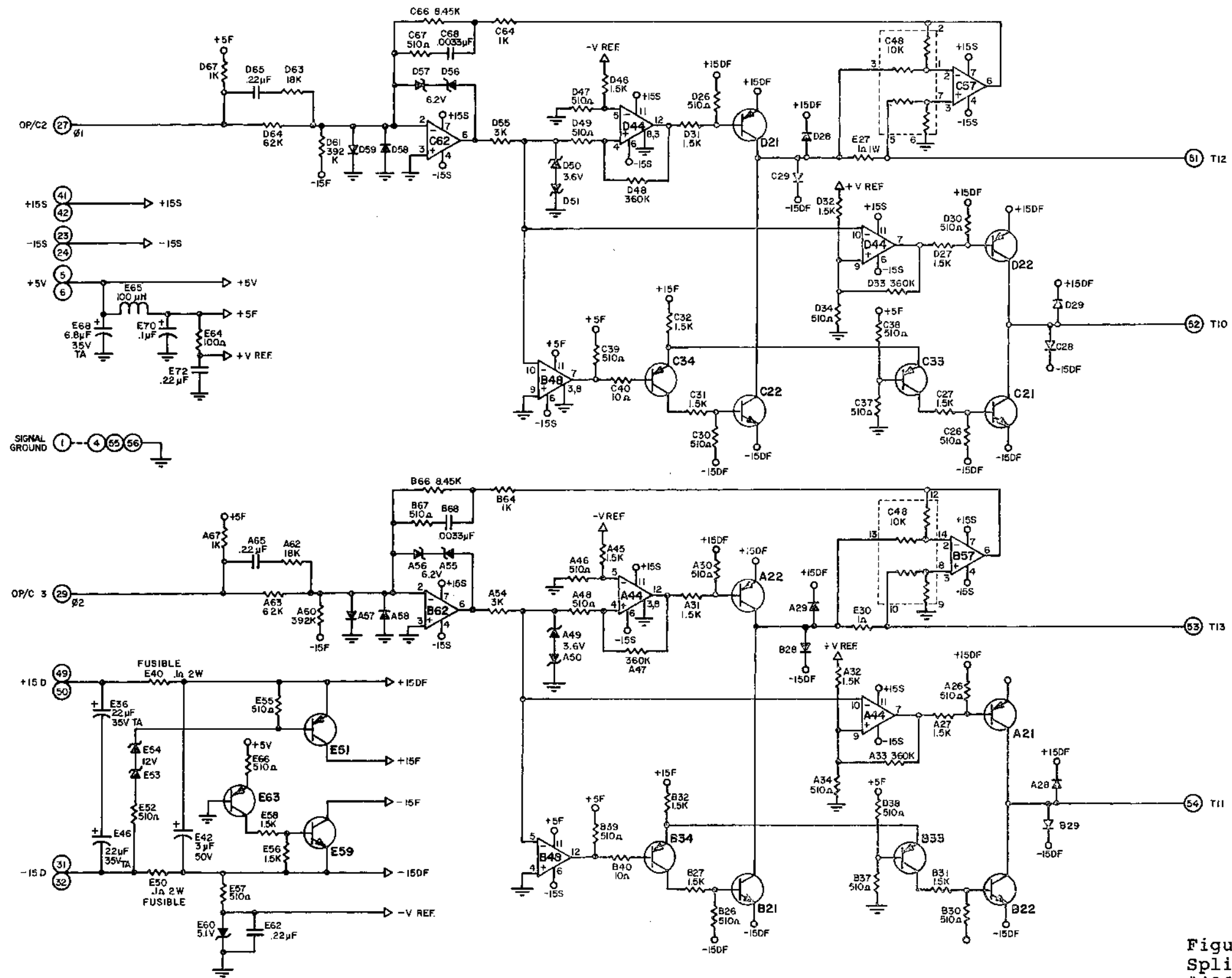

Figure 7-9
 Split Platen Opt. PCB Assy, Std #40617-02
 Rev A

Figure 7-9 Split Platen Option PCB Assy, Std
#40617-02 Rev A

REVISION HISTORY:

REV. ECO# ETCH CONFIGURATION

A A1244 02 As released, etch -02.

SOLID STATE COMPONENTS USED:

IC's	1741		B57,B62,C57,C62
	LM319N		A44,B48,D44
	Resistor Pack 10K		C48
Diodes	1N4729A	Zener 3.6V	A49,A50,D50,D51
	1N5231B	Zener 5.1V	E60
	1M12ZS2	Zener 12V	E53,E54
	1N5234B	Zener 6.2V	A55,A56,D56,D57
	1N5415		A28,A29,B28,B29,C28,C29,D28,D29
	1N4454		A57,A58,D58,D59
Transistors	PN3644		B33,B34,C33,C34,E51,E63
	2N4401		E59
	TIP120		B21,B22,C21,C22
	TIP125		A21,A22,D21,D22

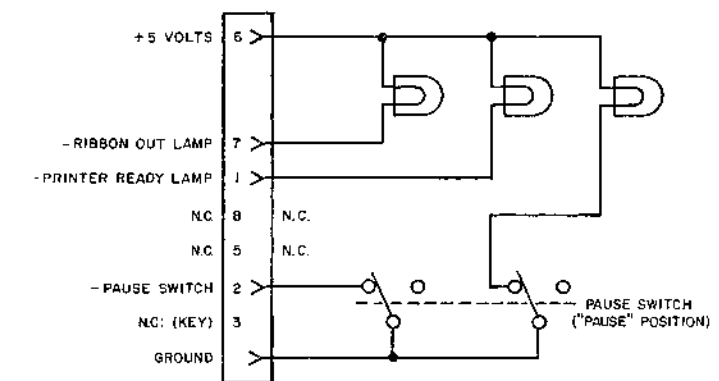
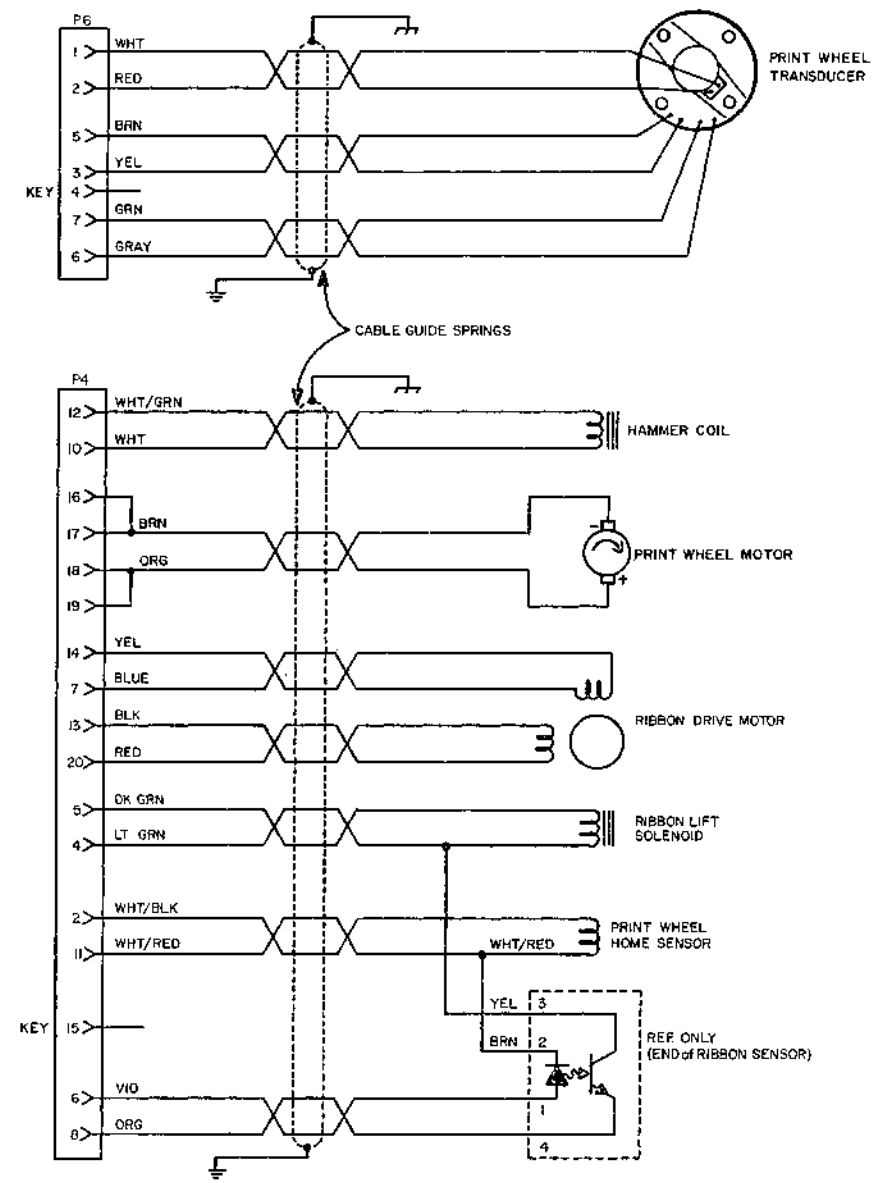
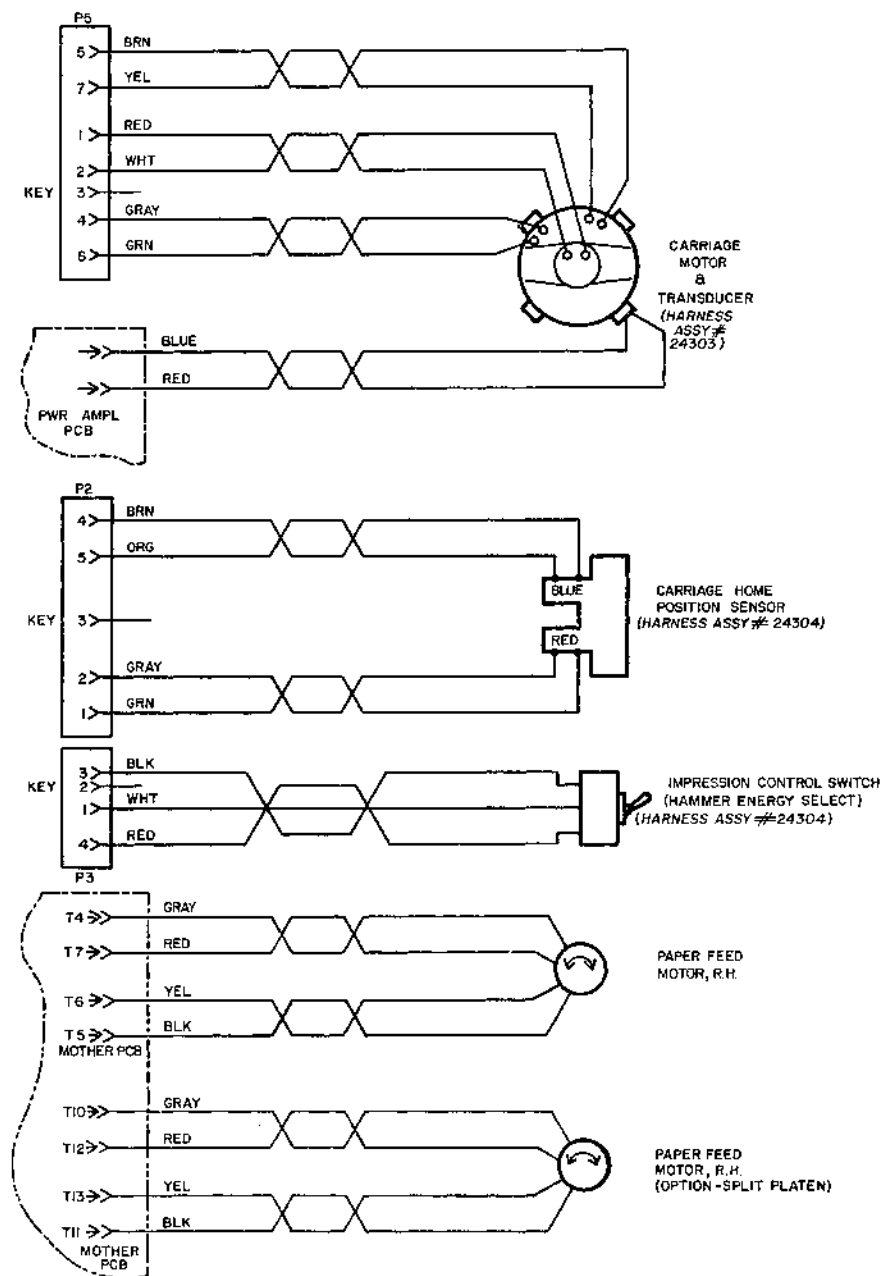

Figure 7-10
Misc. Wire & Cable Assys
(Including #24471 Rev. F, et al)

Figure 7-10 Misc. Wire & Cable Assemblies
(Including #24471 Rev. F, et al)

REVISION HISTORY:

REV.	ECO#	ETCH	CONFIGURATION
A	9684	N/A	As released
B	9797	N/A	Revise documentation and assembly to remove two wires from cable spring to improve flexibility.
C	9901	N/A	Revise documentation and assembly to prevent wire breakage in cable spring.
D	A1102	N/A	Add wiring for L.H. (Split Platen) paper feed motor.
E	A1244	N/A	Exchange L.H. paper feed motor wires: Red T10 to T12 Gray T12 to T10
F	A1582	N/A	Exchange plug P2 wires TO Grn pin 1 Gray pin 2

SOLID STATE COMPONENTS USED:

(No components listed)

Diablo Systems Incorporated

24500 Industrial Boulevard
Hayward, California 94545

A Xerox Company

Reader Comment Form

We would appreciate your comments and suggestions for improving this publication.

Publication No.	Rev. Letter	Title	Current Date
How did you use this publication? <input type="checkbox"/> Learning <input type="checkbox"/> Reference <input type="checkbox"/> Installing <input type="checkbox"/> Maintaining <input type="checkbox"/> Sales <input type="checkbox"/> Operating			
Is the material presented effectively? <input type="checkbox"/> Fully Covered <input type="checkbox"/> Well Illustrated <input type="checkbox"/> Well Organized <input type="checkbox"/> Clear			
What is your overall rating of this publication? <input type="checkbox"/> Very Good <input type="checkbox"/> Good <input type="checkbox"/> Fair <input type="checkbox"/> Poor <input type="checkbox"/> Very Poor			
What is your occupation? <hr/> <hr/> <hr/>			
We welcome your comments. Please give page, paragraph and line numbers for reference. Thank you for your time and interest. <hr/> <hr/> <hr/> <hr/> <hr/> <hr/> <hr/> <hr/> <hr/> <hr/> <hr/> <hr/> <hr/> <hr/> <hr/> <hr/> <hr/> <hr/> <hr/> <hr/> <hr/> <hr/> <hr/> <hr/>			
			YOUR NAME AND RETURN ADDRESS

Cut on Dotted Line

Fold



No Postage
Necessary
If Mailed
in the
United States

BUSINESS REPLY MAIL

First Class Permit No. 956 Hayward, California

Postage will be paid by Addressee

Diablo Systems Incorporated

Attn: Customer Service Publications (B-103)
24500 Industrial Boulevard
Hayward, California 94545 USA



Fold

XEROX

Diablo Systems Incorporated

24500 Industrial Boulevard
Hayward, California 94545

A Xerox Company