



Diablo Systems Incorporated

Model 1200 HyType I Printer Maintenance Manual

WARRANTY

The Model 1200 HyType I Printer is warranted against defective materials and workmanship for 90 days from date of shipment. Any questions with respect to the warranty should be taken up with your Diablo Sales Representative.

All requests for repairs should be directed to the Diablo Repair Depot in your area. This will assure you the fastest possible service.

Diablo Systems, Incorporated, reserves the right to make changes and/or improvements to its products without prior notification, and without incurring any obligation to incorporate such changes or improvements in units previously sold or shipped.

Information in this manual is proprietary and is not to be reproduced or disseminated in any form without written consent of Diablo Systems, Inc.

U.S.A. and foreign Diablo products covered by U.S. and foreign patents and/or patents pending.

"Diablo" and "HyType" are trademarks of Diablo Systems, Inc.

©Copyright 1974 by Diablo Systems, Inc., Hayward, California. Printed in the United States of America.

Publication No. 82003 Second Edition

TABLE OF CONTENTS

SECTION 1—GENERAL DESCRIPTION

1.1 General	1-1
1.2 Operation	1-1
1.3 Interface	1-2
1.4 Power Requirements	1-2

SECTION 2—INSTALLATION

2.1 Installation Requirements	2-1
2.2 Unpacking the Printer and Accessories	2-1
2.3 Preservation of Shipping Containers	2-3
2.4 Power and Interface Connections	2-3
2.5 Initial Checks and Tests	2-3
2.5.1. Power Off	2-3
2.5.2 Power On	2-4

SECTION 3—OPERATING INSTRUCTIONS

3.1 General	3-1
3.2 Installation of the Optional Pin Feed Platen	3-1
3.3 Installation of the Optional Tractor Feed Assembly	3-1
3.4 Paper Loading	3-2
3.4.1 Pressure Feed	3-2
3.4.2 Pin Feed	3-2
3.4.3 Tractor Feed	3-2
3.5 Print Wheel Installation	3-2
3.6 Ribbon Cartridge Installation	3-2
3.7 Cleaning and Maintenance	3-3

SECTION 4—INTERFACING

4.1 General	4-1
4.2 Power Requirements	4-1
4.3 Input-Output Definitions and Characteristics	4-2
4.4 Input Signal Characteristics and Sequence Considerations	4-2
4.4.1 Signal Characteristics	4-2
4.4.2 Signal Sequencing	4-2
4.5 Input Gates	4-3
4.6 Drive Capability of Output Lines	4-3

SECTION 5—PRINCIPLES OF OPERATION

5.1 General	5-1
5.2 Block Diagram	5-1
5.3 Power on Voltage Monitor	5-1
5.3.1 Block Diagram	5-1
5.3.2 Theory of Operation	5-1
5.4 Check Function and Sequence	5-2
5.4.1 Function	5-2
5.4.2 Sequence	5-2
5.5 Restore Function and Sequence	5-2
5.5.1 Function	5-2
5.5.2 Sequence	5-3
5.6 Paper Feed Function and Sequence	5-4
5.6.1 Function	5-4
5.6.2 Sequence	5-4
5.7 Carriage Movement Function and Sequence	5-10
5.7.1 Function	5-10
5.7.2 Sequence	5-10
5.8 Ribbon Lift/Hold Function and Sequence	5-17
5.8.1 Function	5-17
5.8.2 Sequence	5-17
5.9 Print Wheel Movement Function and Sequence	5-18
5.9.1 Function	5-18
5.9.2 Sequence	5-19
5.10 Miscellaneous Circuits	5-31
5.10.1 Clock Generator	5-31
5.10.2 Demod/Transducer Driver	5-32
5.10.3 Print Wheel Zero Position Signal Generator	5-32
5.11 Printer Circuit Interrelation Summary	5-32
5.11.1 Ready Lines	5-32
5.11.2 Interlock Lines	5-32
5.11.3 Restore Function	5-32
5.11.3.1 Initiate	5-32
5.11.3.2 Carriage Movement	5-34
5.11.3.3 Print Wheel Movement	5-34
5.12 Printer Mechanical Systems	5-34
5.12.1 The Platen System	5-34
5.12.2 The Carriage System	5-34
5.12.3 The Print System	5-35

SECTION 6—MAINTENANCE

6.1 General Maintenance Information	6-1
6.1.1 Maintenance Requirements	6-1
6.1.2 Maintenance Instructions	6-1
6.1.3 Maintenance Precautions	6-1
6.2 Maintenance Levels, Tools, Equipment and Spares	6-1
6.2.1 Levels of Maintenance	6-1
6.2.2 Preventive Maintenance Items — Level 1	6-1
6.2.3 Corrective Maintenance Items — Levels 2 and 3	6-1
6.2.3.1 Level 2 — Level 1 Maintenance Items, plus:	6-1

6.2.3.2 Level 3 — Levels 1 and 2 Maintenance Items, Plus:	6-1
6.3 Location of Assemblies	6-2
6.4 Preventive Maintenance — Maintenance Level 1	6-2
6.4.1 Preventive Maintenance Philosophy	6-2
6.4.2 Preventive Maintenance Procedures	6-4
6.4.2.1 Cleaning and Inspection	6-4
6.4.2.2 Lubrication	6-4
6.5 Corrective Maintenance	6-4
6.5.1 Corrective Maintenance Philosophy	6-4
6.5.2 General Troubleshooting Techniques	6-4
6.6 Adjustments	6-4
6.6.1 Adjustments Requirements	6-4
6.6.2 Adjustments — Level 1	6-4
6.6.2.1 Print Intensity Adjustment	6-4
6.6.3 Adjustments — Level 2	6-5
6.6.3.1 Card Guide/Ribbon Guide Adjustment	6-5
6.6.3.2 Paper Pressure Roller Adjustment	6-5
6.6.3.3 Print Hammer Adjustment	6-6
6.6.3.3.1 Align the Print Hammer	6-6
6.6.3.3.2 Align the Print Hammer/Armature Assembly	6-6
6.6.4 Adjustments — Level 3	6-7
6.6.4.1 Carriage Drive Cable Adjustment	6-7
6.6.4.2 Carriage Height (Print) Adjustment	6-7
6.6.4.3 Carriage Mechanical Stop Adjustment	6-7
6.6.4.4 Platen Adjustments	6-7
6.6.4.4.1 Horizontal Adjustment	6-7
6.6.4.4.2 Vertical Adjustment	6-8
6.6.4.4.3 Platen Release Adjustment	6-8
6.6.4.5 Ribbon Adjustments	6-8
6.6.4.5.1 Ribbon Platform Alignment	6-8
6.6.4.5.2 Ribbon Lift Height Adjustment	6-9
6.6.4.6 Paper Feed Drive Gear Adjustment	6-9
6.6.4.7 Print Wheel Home “O” Adjustment	6-9
6.6.4.8 Print Wheel Alignment (timing)	6-9
6.7 Removal and Replacement of Assemblies	6-9
6.7.1 Level 1	6-9
6.7.2 Level 2	6-9
6.7.3 Level 3	6-11
6.7.3.1 Carriage Assembly Replacement	6-11
6.7.3.2 Carriage Drive Motor Replacement	6-11
6.7.3.3 Paper Feed Motor Replacement	6-11
6.7.3.4 Carrier Assembly Replacement	6-11

SECTION 7—LOGIC DIAGRAM CONVENTIONS, LOGIC DIAGRAMS

7.1 General	7-1
7.2 Signal Nomenclature	7-1
7.3 Interpage Referencing	7-1
7.4 Logic Symbology	7-2

SECTION 1
GENERAL DESCRIPTION

1.1 GENERAL

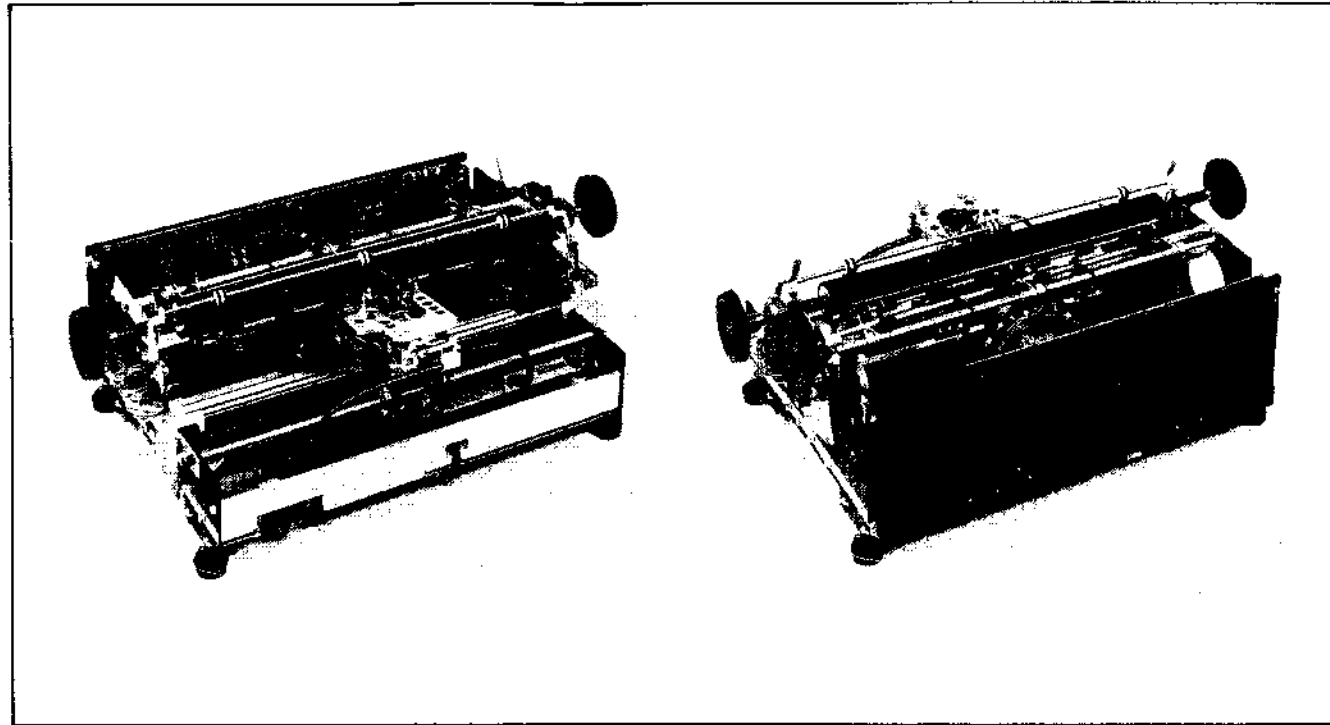

FIGURE 1-1
MODEL 1200 HYTYPE 1 PRINTER

The Diablo Model 1200 series HyType I Serial Printer is a compact, highly reliable unit designed for any application where a medium speed printer is required, such as small computer systems.

Its small size, low power consumption, and quiet operation make the HyType I Printer ideal for office environments. The unique electronic control techniques used in this printer eliminate most of the moving parts found in conventional printers. The accuracy, reliability, and freedom from wear or misalignment allowed by these electronic methods help assure the continuous output of top quality printing under the heavy-duty operating conditions required in computer based systems.

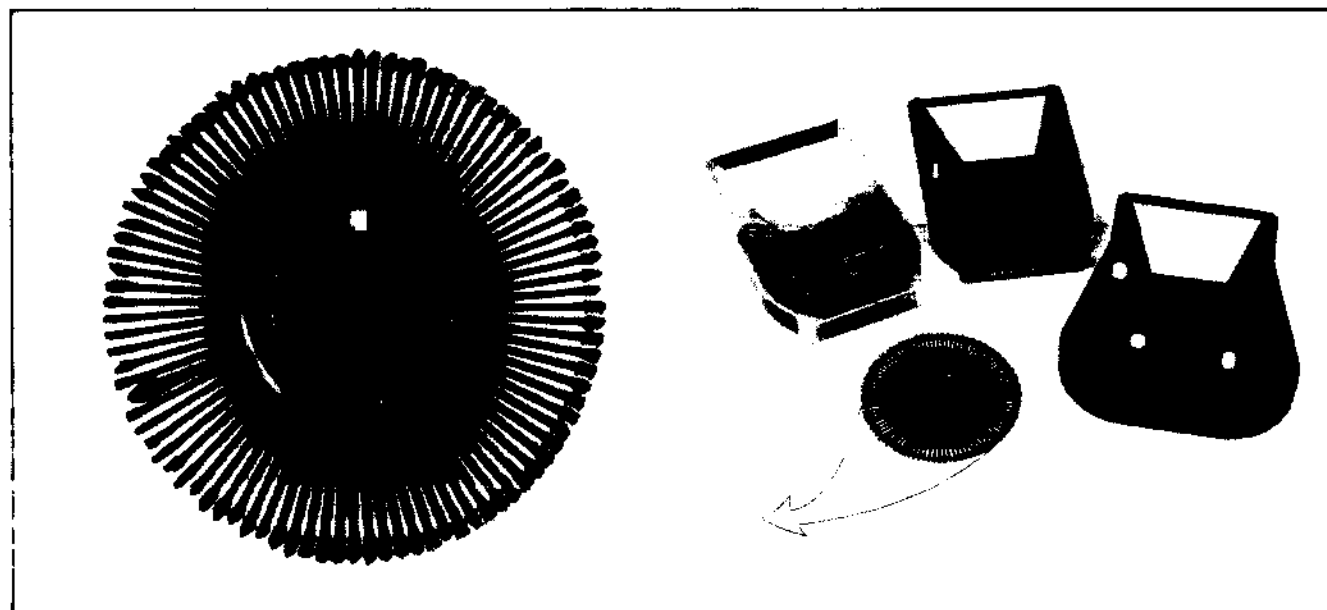

FIGURE 1-2
RIBBON CARTIRDGES AND THE PRINT WHEEL

TABLE 1-1
PERFORMANCE SPECIFICATIONS

CHARACTER SET	96 Characters
PRINT SPEED	30 Characters per second on average text
PRINT LINE	132 Columns @ 10 characters/in. (3.95 char/cm) 158 Columns @ 12 characters/in. (4.76 char/cm)
FORMS WIDTH	15 inches (38.1 cm) (16 in. maximum on special order only without covers)
PAPER FEED	Up or down with equal speed
PAPER FEED SPACING	48 Positions/in. (18.9 pos./cm) (up to 1023 positions or 21 5/16" per command)
PAPER FEED SPEED	4 Inches/sec. (10.16 cm/sec.) plus 45 msec settling delay
TABULATION	Right or left to commanded address
TABULATION SPEED	400 msec maximum for 13.2 inches (33.53 cm)
COLUMN SPACING	60 Positions/in., 1/60th in./increment (23.6 pos./cm 152.4 mm/increment)
CARRIAGE RETURN TIME	400 msec maximum for 13.2 inches (33.53 cm)
POWER REQUIREMENTS	+5 Vdc @ 4A ±2% regulated +15 Vdc @ 9A peak ±5% regulated -15 Vdc @ 9A peak ±5% regulated 100W typical average power dissipation
PHYSICAL PARAMETERS	Height: 8.55 inches (21.72 cm) Width: 23.10 inches (58.67 cm) Depth: 13.11 inches (33.30 cm) Weight: 30 pounds (13.60 kg)
FEATURES:	
Platen	Standard pressure or optional pin feed types
Auxilliary Feed	Optional tractor feed for continuous form paper
Print Characters	Operator interchangeable print wheel
Ribbon	Operator changeable, cartridge loaded, fabric or multi-strike carbon. Fabric ribbons are available in one or two colors.

1.2 OPERATION

The HyType I Printer imprints up to 30 characters per second; up to 158 columns per line; up to 48 lines per inch, on sheet or continuous form paper. It utilizes a snap-in ribbon cartridge, and an easily exchanged print (character) wheel or font for rapid change of type styles or language.

Carriage and print wheel movement, for horizontal tabbing and character selection, are both achieved by the use of field proven servo techniques for fast, accurate positioning. These servo systems, including the unique non-contacting rotary transducer, have proven to be highly reliable in the field. Carriage (print head) movement is bi-directional along the 13.2 inch horizontal print line. Velocity depends on the distance to be traveled, and the smallest increment of movement is 1/60th of an inch.

Print wheel rotation, to locate the next character to be printed in front of the print hammer, is 180° maximum. Again, velocity of print wheel rotation depends on the distance to be traveled. The print wheel, called a "daisy", is a simple plastic disk with 96 "petals" with each "petal" carrying one of the print characters. See Figures 1-2 and 5-36. The HyType I Printer is supplied with a standard print wheel. Others are listed in the Parts Catalog and Sales Brochures.

Paper and ribbon feed are both achieved by the use of reliable, proven stepper motors and gear trains.

Paper movement is bi-directional. The smallest increment of movement is 1/48th of an inch, and the maximum movement up or down with one command is 21-5/6 inches (1023 increments).

Ribbon movement is in one direction only, to continuously circulate the looped one and two color fabric ribbons contained in the ribbon cartridges. The carbon ribbon is not looped, and therefore does not circulate. Ribbon advancement is

approximately 1/10th of an inch per character printed, for the fabric ribbons, and approximately 1/60th of an inch for the carbon ribbon. The different feed speeds are accomplished within the ribbon cartridges themselves, and selective ribbon feed facilities are therefore not required in the printer itself, nor are special command features required of the controller. The HyType I Printer is supplied with a one-color fabric ribbon cartridge. Others are listed in the Parts Catalog and Sales Brochures.

Paper loading is accomplished in a manner similar to standard typewriter techniques. Optional paper handling equipment, such as a pin feed platen (Figure 1-3), and a tractor feed attachment (Figure 1-4) are available, and are easily installed by the operator.

Operation of the HyType I Printer is controlled from the using system. There are no power switches or other controls on the printer available to the operator, other than the platen pressure release lever, manual platen knobs, and the ribbon and carriage tilt release levers.

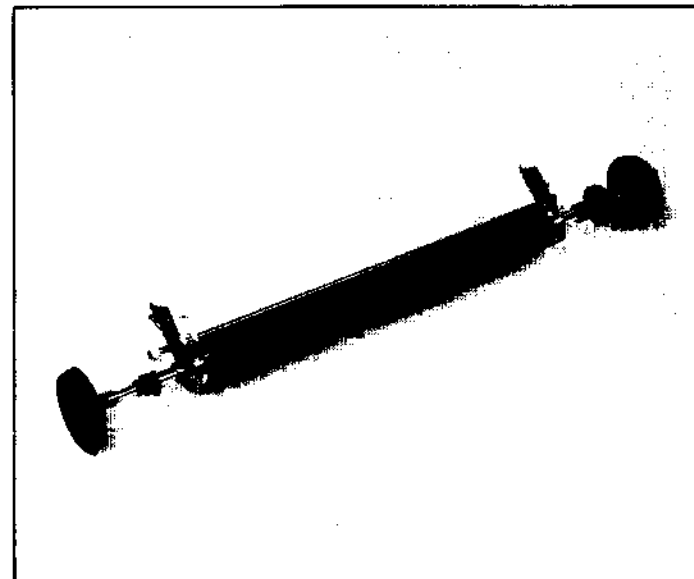

FIGURE 1-3
THE PIN FEED PLATEN

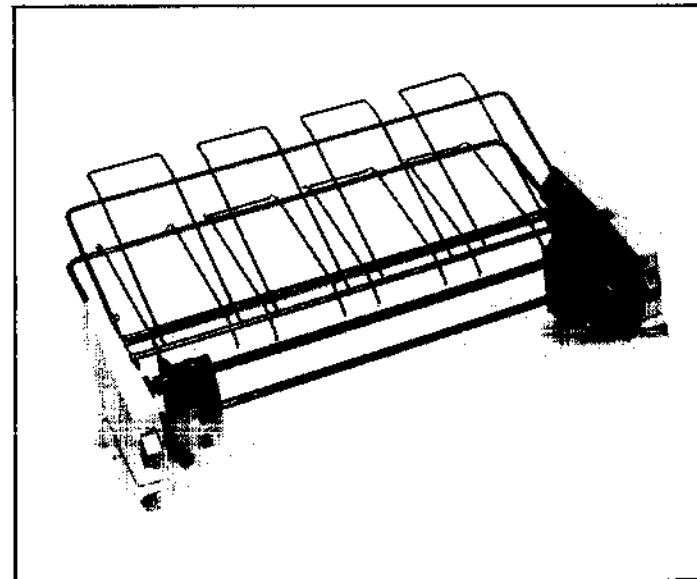

FIGURE 1-4
THE TRACTOR FEED ASSEMBLY

CAUTION: Power must be removed from the system when connecting or disconnecting the HyType I Printer.

The HyType I Printer is designed to be incorporated into larger systems. As such, it is furnished without a cover. To aid in customizing its installation on OEM systems, Diablo offers a variety of optional cover assemblies. Table 1-2 below identifies the various cover options available by their Diablo Part Number, and indicates the applicability of each. Figure 1-5 shows the two cover styles listed in the table.

TABLE 1-2
HYTYPE I PRINTER COVER OPTIONS

Model	Table Top	Flush Mount
Receive Only, Plain or Pin Feed	22343	NA
Receive Only, Tractor Feed	22346	NA
Send-Receive, Plain or Pin Feed	22342	22341
Send-Receive, Tractor Feed	22345	22344

Two paper feed system options are offered. The first is the Pin Feed Platen, and the second is the Tractor Feed Assembly. The Pin Feed Platen snaps into the printer in place of the standard platen. It provides a pin drive paper guide wheel and hold-down plate at each end of the platen. The Tractor Feed Assembly clips into place over the standard platen. It offers pin feed drives and hold-down plates on each side which are adjustable for different width forms.

1.3 INTERFACE

The HyType I Printer makes use of 25 signal lines for proper operation with a using system and its controller. The interface logic consists of input, output, and gating circuits, where 0 Vdc nominal (LO) represents the "TRUE" or active condition, and +5 Vdc nominal (HI) represents the "FALSE" or inactive condition.

Eleven data *input* lines are used to receive operating movement (distance and direction) commands from the controller.

These commands are Carriage or print head movement, Paper Feed movement, and ASCII Character Selection for print wheel positioning.

Six data *output* lines are used by the printer to update the controller as to present printer status. These are Printer Ready, Paper Out, Print Wheel Ready, Carriage Ready, Paper Feed Ready, and Check.

Eight command lines complete the interface. These are Restore, Select Printer, Select Ready, Carriage Strobe, Character Strobe, Paper Feed Strobe, Ribbon Lift, and External Reset (not used in normal operations).

Interface cabling should consist of a conventional round cable made up of 25 twisted pairs of wires. Wire size can be 28 or 30 AWG, and the maximum tested length is 25 feet.

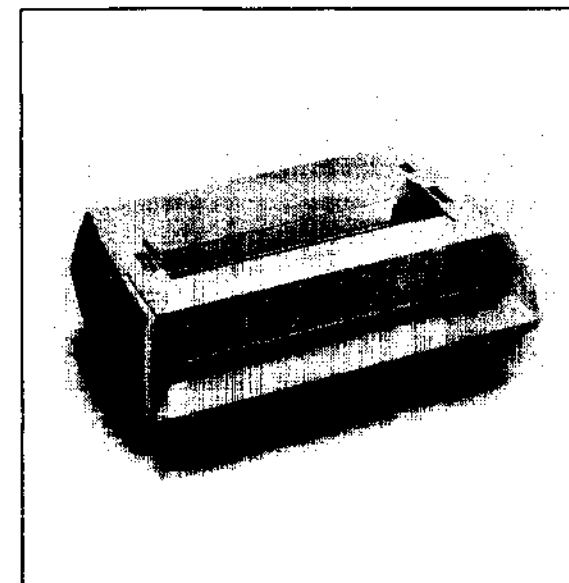

FIGURE 1-5A
THE RECEIVE ONLY COVER

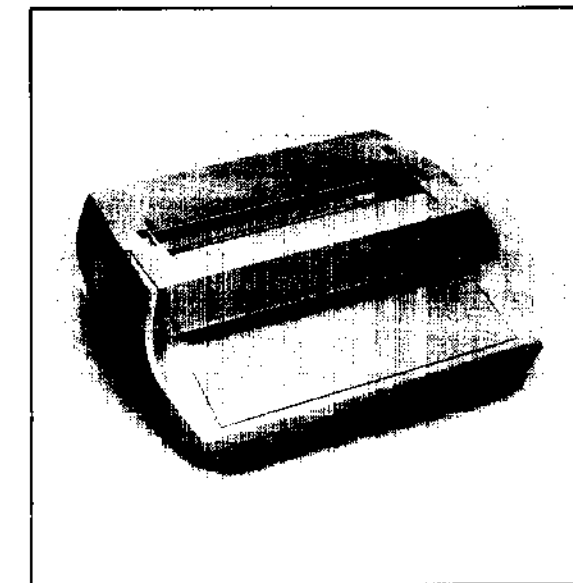

FIGURE 1-5B
THE SEND-RECEIVE COVER

1.4 POWER REQUIREMENTS

The HyType I Printer requires +15 and -15 Vdc, regulated to within $\pm 5\%$, and +5 Vdc, regulated to within $\pm 2\%$. The ± 15 Vdc current demand is 4 Amperes average, with instantaneous peaks of 9 Amperes for a nominal period of 10 milliseconds. The +5 Vdc current demand is 4 Amperes.

In the printer, the 15 volt supply lines are separated into high and low current demand circuits. To avoid common impedance, separate supply lines for these high and low level circuits are recommended. The +5 Vdc supply should be provided its own ground return circuit. The wire size requirements for a five foot cable are:

+15 Vdc High Current	14 AWG
+15 Vdc Low Current	16 AWG
-15 Vdc High Current	14 AWG
-15 Vdc Low Current	16 AWG
+5 Vdc	14 AWG
± 15 Vdc Ground Returns	12 AWG Flat Braid
+5 Vdc Ground Return	16 AWG Flat Braid

Diablo's Model 1329 Power Supply has been designed specifically for use with the HyType I Printer.

For additional information, see Section 4.

SECTION 2 INSTALLATION

2.1 INSTALLATION REQUIREMENTS

The general shape and dimensions of the HyType I Printer alone are shown in Figure 2-1. Figure 2-2 shows the general shape and dimensions of the HyType I Printer *and* its Diablo cover assemblies, and includes the optional Diablo Tractor Feed Assembly.

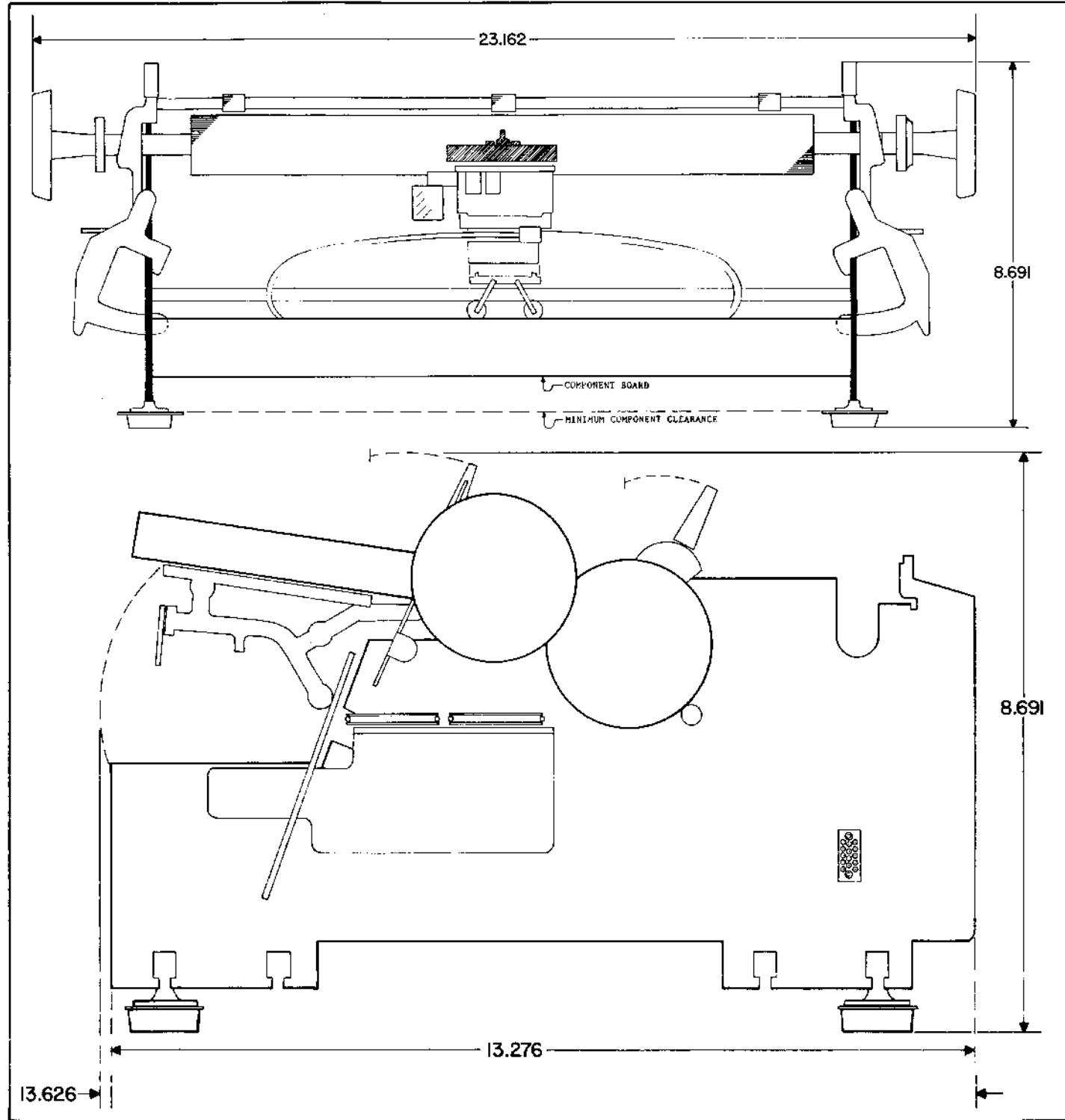

FIGURE 2-1
HYTYPE I PRINTER — WITHOUT COVER

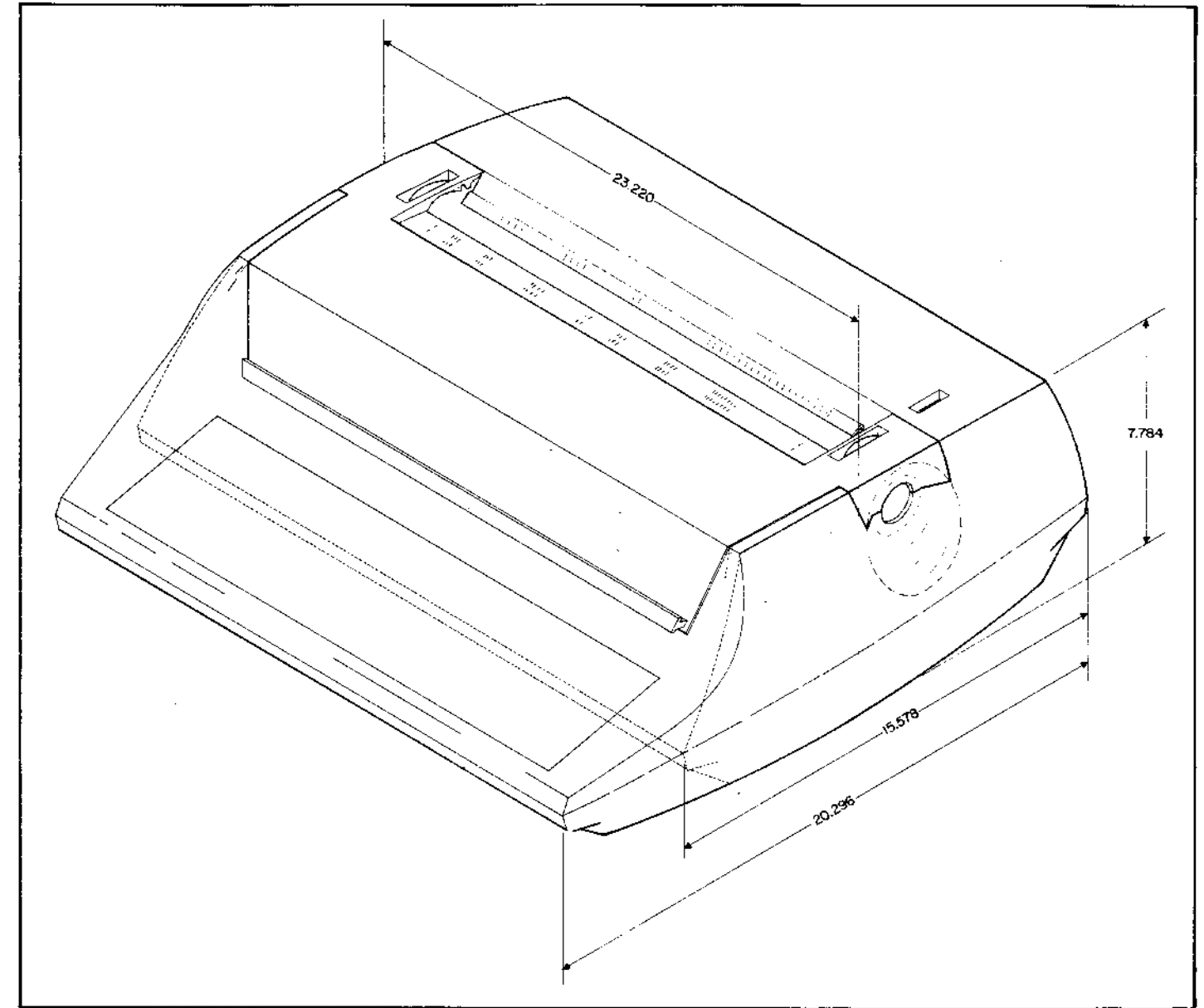

FIGURE 2-2
HYTYPE I PRINTER — COVER

Weight, stability, interconnection, and operating considerations.

- (1) The HyType I Printer assembly weighs approximately 30 pounds without covers. With covers, the weight is approximately 45 pounds. With covers and Tractor Feed Assembly, the machine weighs approximately 52 pounds.
- (2) In operation, the rapid movement of the carriage generates a sideways thrust proportional to carriage velocity. This sideways thrust, plus the weight of the machine, should be kept in mind when planning the location of the printer.
- (3) The maximum recommended lengths for the HyType I Printer's interconnecting cables are: 5 feet for the power cable; and 25 feet for the interface cable. Printer performance may deteriorate if greater lengths of cable are used.
- (4) The HyType I Printer is designed so that all heat generating components are located for optimum heat dissipation. The rear panel is finned to aid this process. Care should be taken to allow adequate air circulation both around the rear "heat sink" panel, and up through the bottom of the unit. In those instances where the printer is to be operated covered in temperature environments greater than 95°F, the user should provide at least 50CFM fan in the cabinet to circulate air through the unit.

2.2 UNPACKING THE PRINTER AND ACCESSORIES

The basic HyType I Printer is packed as shown in Figure 2-3. It should be unpacked in the following manner.

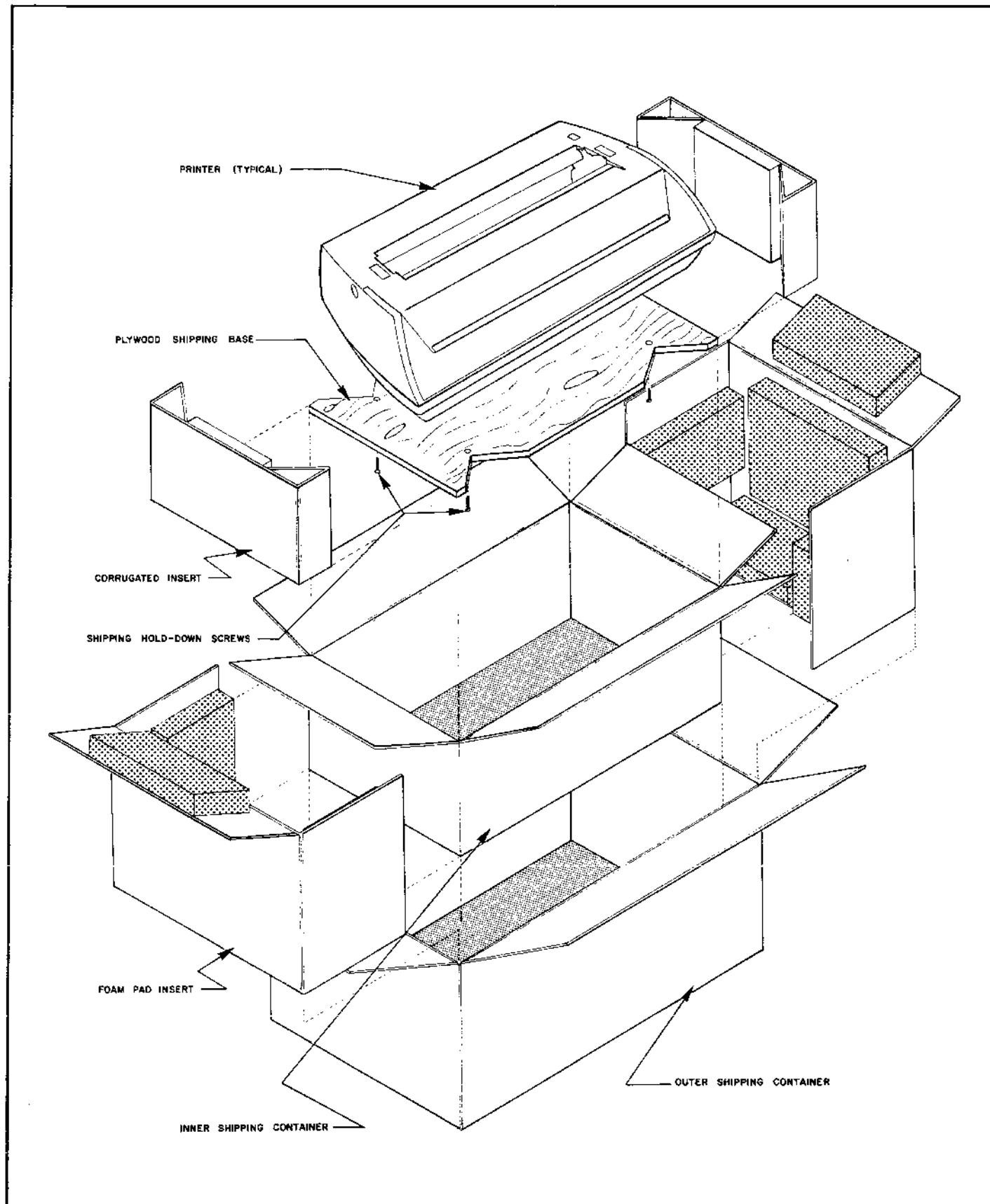

FIGURE 2-3
UNPACKING HYTYPE I BASIC PRINTER

- (1) Open the outer and inner containers, as shown. Locate and retrieve the print wheel and ribbon cartridge.
- (2) Remove the printer and its plywood shipping base. Stand the printer and base up on the printer's finned back panel (heat sink), making sure it is stable and will not fall over. Remove the four shipping screws holding the printer to the base, and remove the base. Return the printer to its normal upright position.
- (3) Do not discard any of the shipping materials. See Paragraph 2.3 below.

The HyType I Printer, when shipped with covers installed, is packed as shown in Figure 2-3. The container and inner materials are proportionally larger to accommodate the bulkier machine. Again, do not discard any of the shipping materials. See section 2.3 below.

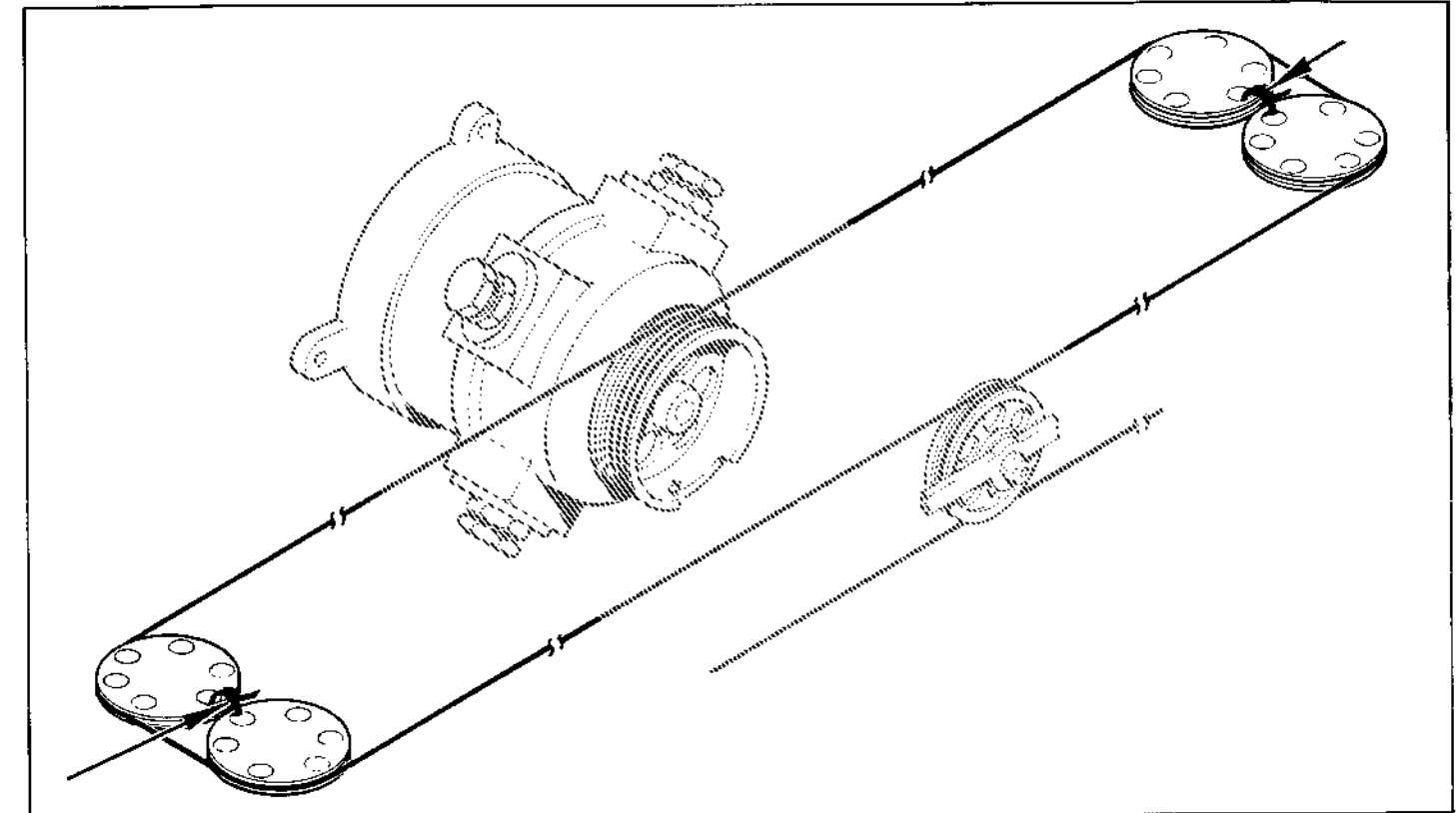

FIGURE 2-4
HYTYPE I PRINTER — CARRIAGE SHIPPING CLAMPS

The HyType I Printer is shipped with plastic cable ties threaded through the carriage cable pulley wheels at *each end* of the frame, as shown in Figure 2-4. Cut and remove these TWO cable ties, along with any tags left attached to the printer.

CAUTION: Do NOT connect the printer to the using system until these ties have been removed.

The Tractor Feed Assembly is packed as shown in Figure 2-5.

- (1) Open the shipping box and lift out the wrapped bundle containing the assembly.
- (2) Carefully unwrap the bundle, and remove the assembly. Immediately inspect the assembly for shipping damage. Report any damage found in the usual manner.
- (3) Do not discard any of the shipping materials. See paragraph 2.3 below.

The Pin Feed Platen is packed as shown in Figure 2-6.

- (1) Open the shipping box. Lift out the top half of the shipping support.
- (2) Lift out the Pin Feed Platen. Immediately inspect the assembly for shipping damage. Report any damage found in the usual manner.
- (3) Do not discard any of the shipping materials. See Paragraph 2.3 below.

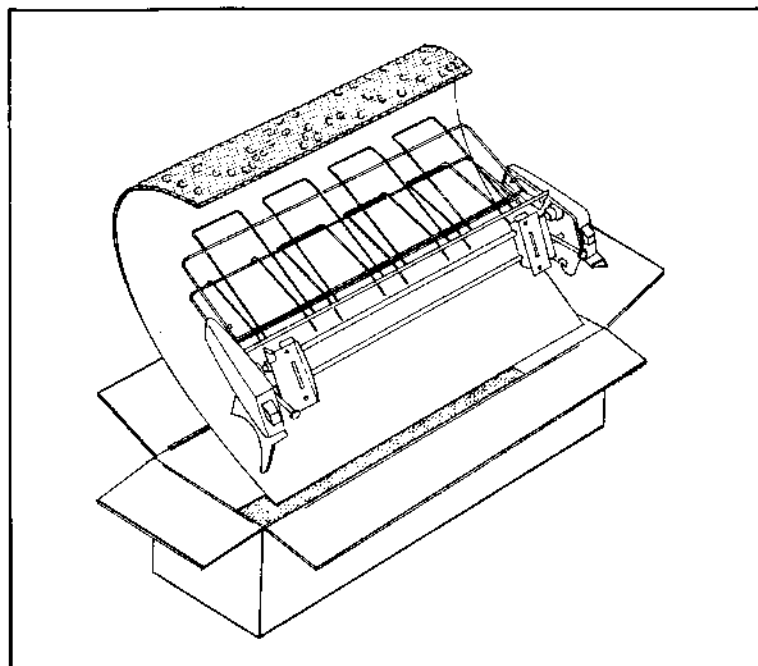

FIGURE 2-5
UNPACKING THE TRACTOR FEED ASSEMBLY

2.3 PRESERVATION OF SHIPPING CONTAINERS

Diablo Systems, Inc., has carefully designed its shipping containers to adequately support the unit packed inside, and to protect the unit from damage under normal conditions of handling and transporting. Owners are advised to retain adequate supplies of each type of shipping container for use in reshipment of units.

NOTE: Diablo Systems, Inc., may, at its sole discretion, disclaim warranty responsibility for units shipped improperly packed.

2.4 POWER AND INTERFACE CONNECTIONS

CAUTION: Always remove power before making or breaking connections to or within the HyType I printer.

Plug the power cable into its jack on the right rear side frame, as shown in Figure 2-7 A. Plug the data cable into its jack inside the printer on the right rear bottom pan, as shown in Figure 2-7 B. Make sure the plugs are properly oriented, and then tighten their hold-down screws finger tight.

For those units equipped with Diablo designed covers, it will be necessary to remove the top cover and platen, and loosen the bottom cover, in order to connect the printer to its using system.

- (1) Swing the top access lid up and back out of the way.
- (2) Remove the platen by grasping the platen knobs in each hand, pressing down on the platen release tabs with the thumbs, and lifting the platen clear of the printer. See Figure 2-8A.
- (3) Remove the top cover by grasping it along the top edges near the front break, and extending the thumbs down inside to release the catches. The top cover may then be lifted clear of the printer and bottom cover. See figure 2-8B.
- (4) Stand the printer on its finned back panel, and loosen the bottom cover screws located in the center of the four rubber feet.
- (5) Carefully return the printer to its upright position, remembering that it is loose in the bottom cover. Lift the right side of the printer itself, to gain access to the two notches in the right hand end of the finned heat sink. Route the two interconnecting cables through these notches.

2.5 INITIAL CHECKS AND TESTS

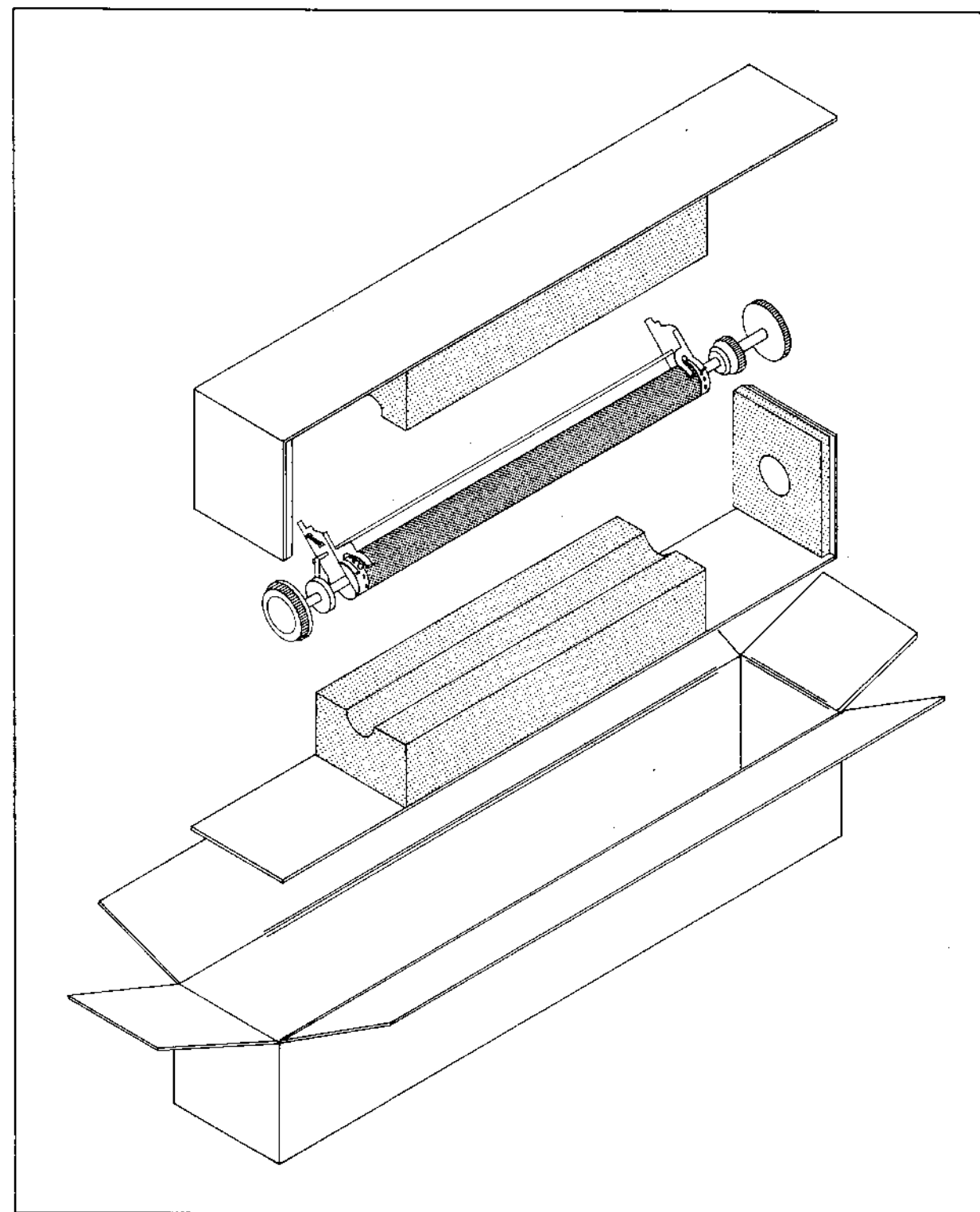

FIGURE 2-6
UNPACKING THE PIN FEED PLATEN

2.5.1 Power Off

- (1) Verify that the platen turns freely without binding, and that the pressure release is effective along the length of the platen.
- (2) Verify that the carriage moves freely and smoothly along the entire length of the carriage rails.
- (3) Verify that the print wheel motor shaft turns freely, and that the ribbon cartridge support plate is free to tilt up.

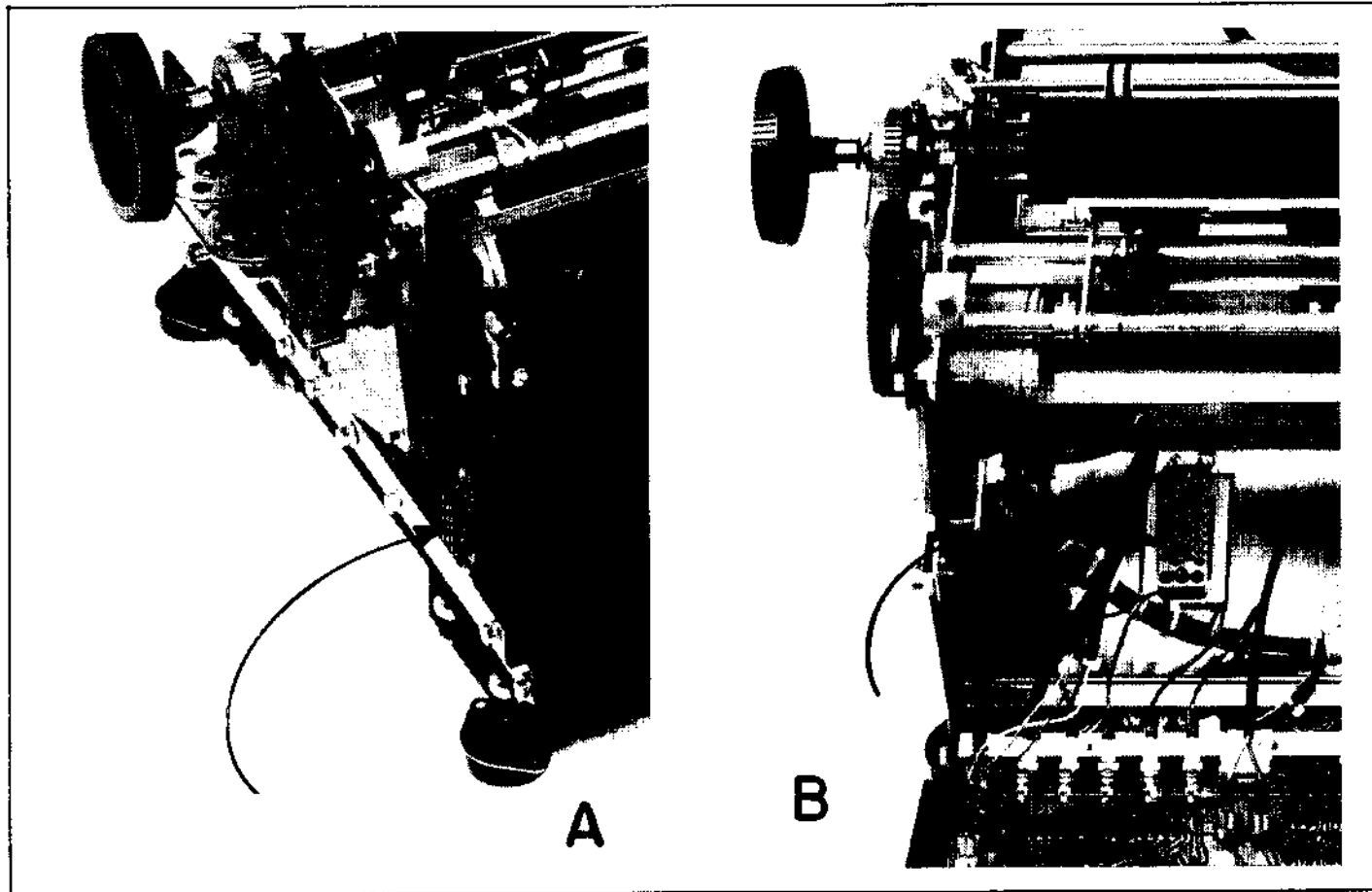

FIGURE 2-7 *
POWER AND INTERFACE CONNECTIONS

2.5.2 Power On

- (1) Turn Power on.

NOTE: Power is controlled from the using system.

- (2) Verify that the carriage assembly moved slowly to the left mechanical stop, paused, and then quickly spaced back to the right *about* 1/5 inch.
- (3) Verify that the carriage is now immovable.
- (4) Carefully touch the end of the print wheel motor shaft with a finger tip, and verify that the shaft is difficult to turn.

Successful completion of these checks indicates the printer is operating properly to this point. *Any* deviation from the start-up responses outlined above may be assumed to indicate a problem in the printer.

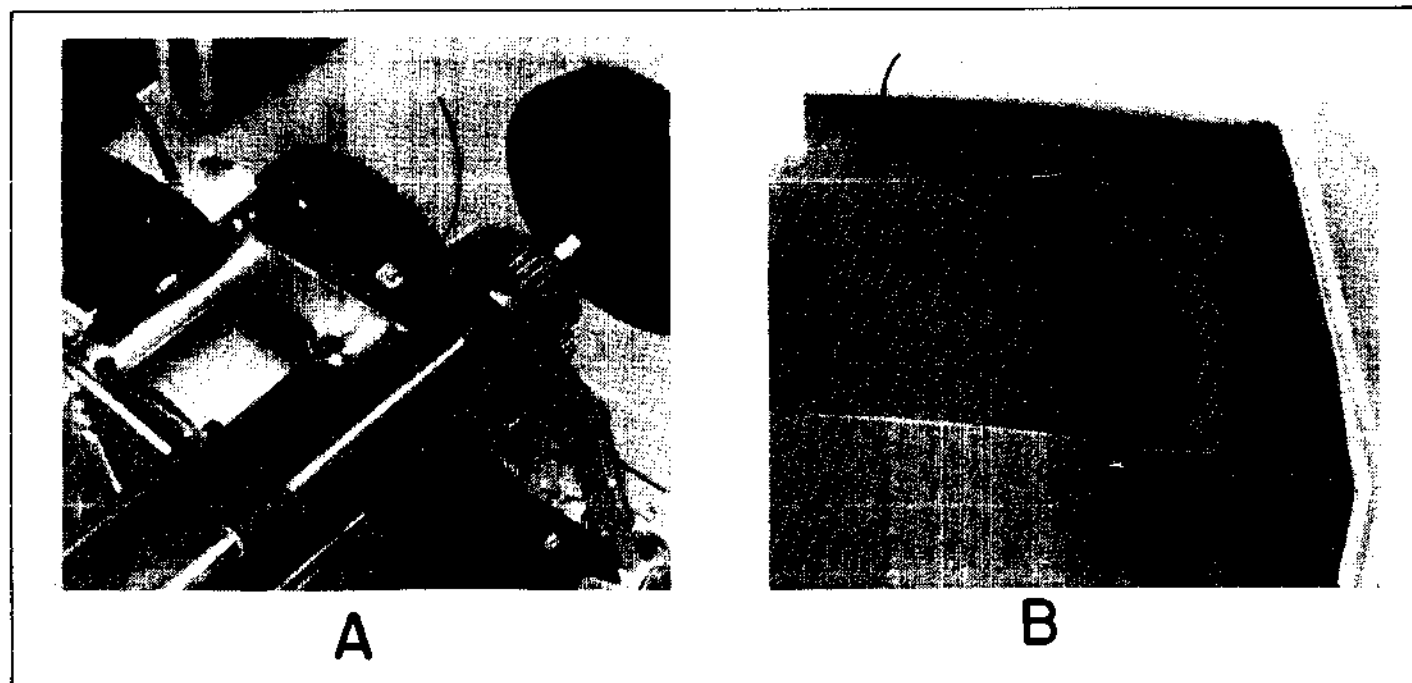

FIGURE 2-8
PLATEN AND COVER REMOVAL

SECTION 3 OPERATING INSTRUCTIONS

3.1 GENERAL

The primary functions to be performed by an operator are; loading paper, changing the ribbon cartridge, exchanging print wheels, and performing periodic cleaning and maintenance chores.

Secondary functions to be performed by an operator include installation of optional paper feed assemblies, and other similar accessories which may become available from time to time.

3.2 INSTALLATION OF THE OPTIONAL PIN FEED PLATEN

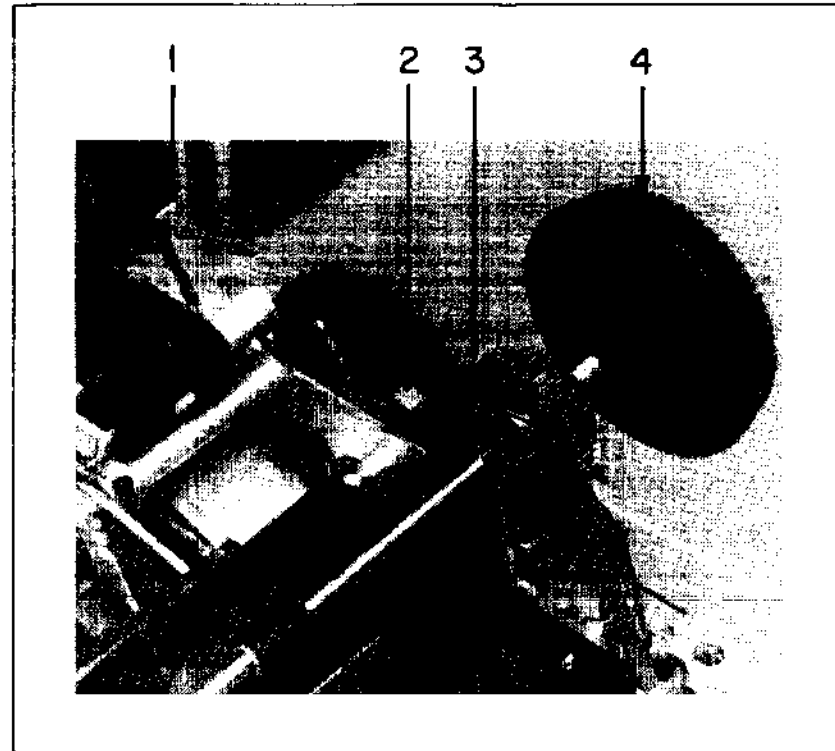

FIGURE 3-1
PLATEN REMOVAL

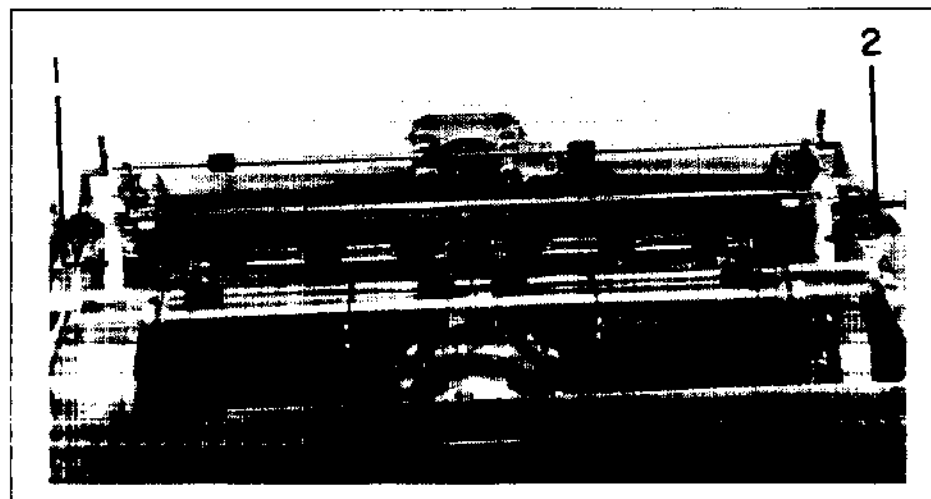

FIGURE 3-2
PIN FEED PLATEN INSTALLATION — FIRST PART

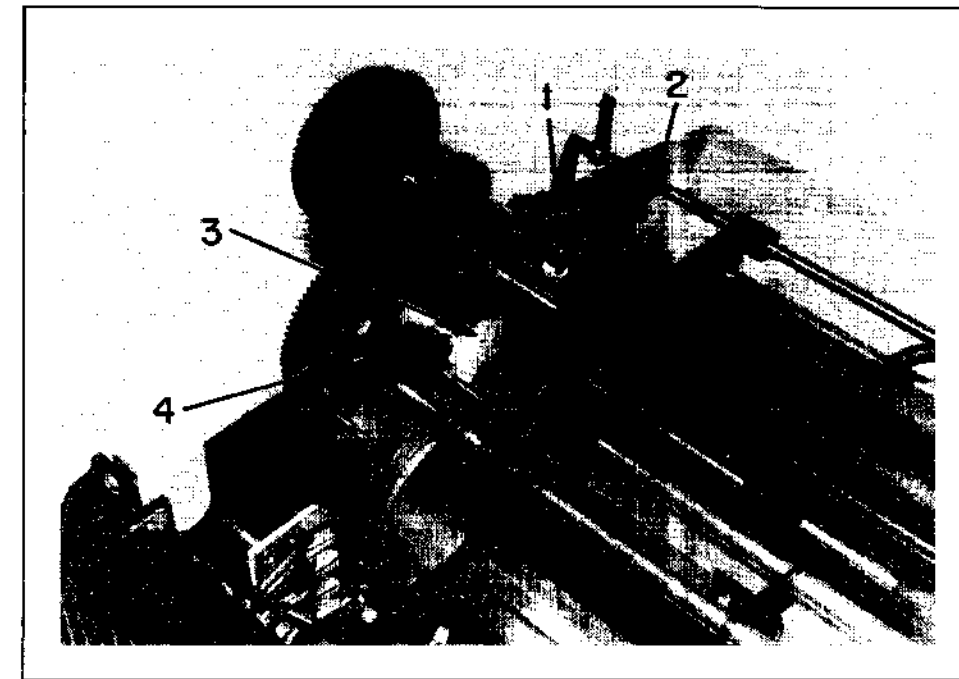

FIGURE 3-3
PIN FEED PLATEN INSTALLATION — SECOND PART

- (1) Refer to Figure 3-1. Pull both the platen pressure release lever (1) and the paper bail assembly (3) forward. Remove the platen by grasping a platen knob (4) in each hand while pressing down on the platen release tabs (2) with the thumbs, and lifting the platen out of the printer frame.
- (2) Refer to Figure 3-2. Place the Pin Feed Platen in the printer frame, in the same location as the regular platen just removed, with the white plastic braces (1) and (2) hanging down behind the platen shaft. Press the platen release tabs to lower the pin feed platen into operating position.
- (3) Refer to Figure 3-3. With the Pin Feed Platen in position and latched down, rotate the paper gates (1) forward against the paper bail assembly (2), and then back far enough to engage the lower ends of the white plastic braces (3) on the round frame member below (4). Force the paper gate assemblies back into operating position. The braces will snap into place on the round shaft as shown, to secure the paper gates in proper position, and the printer with Pin Feed Platen is now ready for use.

NOTE: With the Pin Feed Platen installed, the platen pressure release lever (Figure 3-1 #1) must be left in the forward or OFF position.

3.3 INSTALLATION OF THE OPTIONAL TRACTOR FEED ASSEMBLY (on machine with covers)

- (1) Remove the platen and top cover, per instructions in Section 2.
- (2) Completely remove the top cover's access lid and paper guide scale.
- (3) Return the top cover and the platen to the machine.
- (4) Pull both the paper bail and the platen pressure release lever forward.
- (5) Carefully lower the Tractor Feed Assembly down over the platen, as shown in Figure 3-4, until its rubber feet (1) are resting on the machine's back cover, and its clamps (2) are resting on the platen shaft.
- (6) Press the two clamp buttons (3), and lower the assembly down on the platen shaft. Release the buttons to clamp the assembly to the shaft.
- (7) Verify that a tab under the right hand end of the tractor Feed Assembly extends down and prevents the platen pressure release lever from moving back into its ON position.

The Tractor Feed Assembly is now ready for use. The two belt drives may be adjusted to the form width in use by loosening the thumb-wheel clamps (4), and sliding the drives sideways into position.

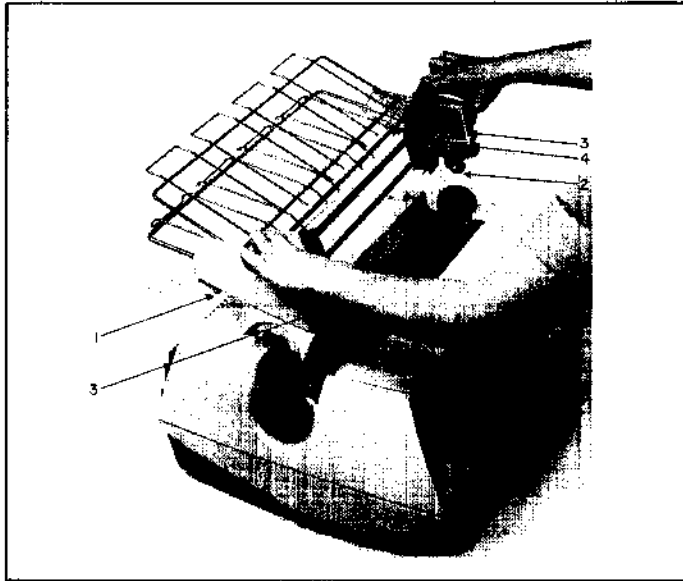

FIGURE 3-4
TRACTOR FEED

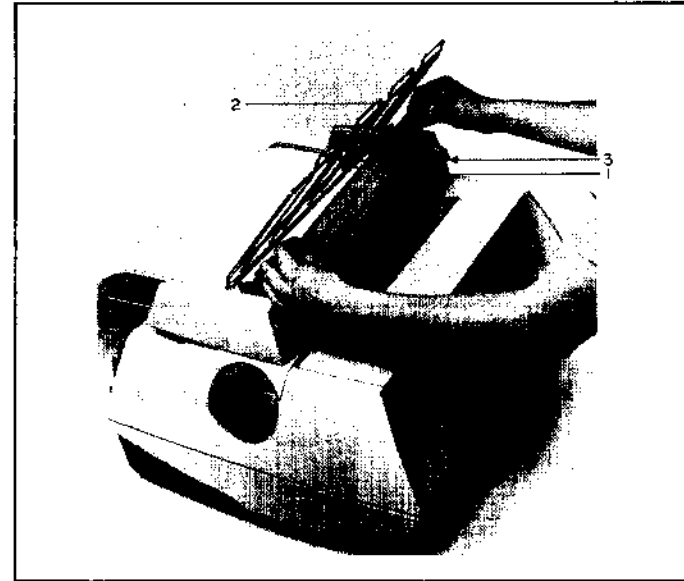

FIGURE 3-5
TRACTOR FEED PAPER LOADING

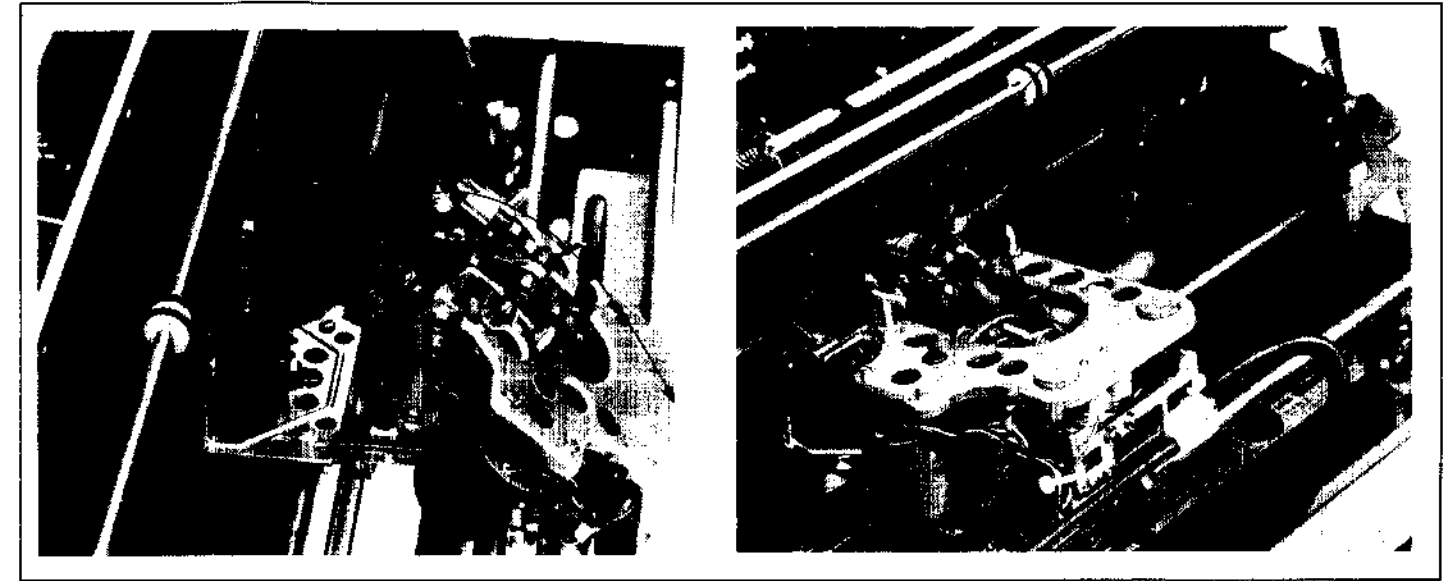

FIGURE 3-6
PRINT WHEEL INSTALLATION — STEP 1

3.4 PAPER LOADING

3.4.1 Pressure Feed

Normal platen machines are loaded (paper inserted) as with a standard typewriter.

- (1) Pull the paper bail and pressure release lever forward.
- (2) Insert the end of the paper from behind the platen, as with a typewriter. Bring the paper up in front of the platen, and lay it back over the platen on itself for proper alignment.
- (3) Hold the paper taut, return the pressure release lever back to its ON position, and swing the paper bail back into position.

3.4.2 Pin Feed

Machines with the optional Pin Feed Platen installed are loaded (paper inserted) as follows:

- (1) Open the paper gates at each end of the platen by flipping them up, to expose the drive pins and the ends of the platen.
- (2) Work the paper from down behind the platen until it extends up in front of the platen high enough to be grasped.
- (3) Pull the paper up evenly at least 8 inches, lay it back on itself for alignment, and engage its edge holes on the drive pins.
- (4) Ensure that the paper is even, and that opposite holes are engaged on the drive pins, and then close the paper gates by snapping them down.

3.4.3 Tractor Feed

Machines with the optional Tractor Feed Assembly installed are loaded (paper inserted) as follows:

- (1) Open the paper gates on each side of the assembly (1) by swinging them up and out.
- (2) Raise the upper paper support rack (2) by tilting it forward.
- (3) Feed the paper in *over* the lower paper support rack, from behind, and down behind the platen until it extends up in front of the platen high enough to be grasped.
- (4) Lay the paper back onto the drive belts to the width of the form. Loosen the thumb-wheel clamps (3) and adjust the belt locations as required. Retighten the clamps.
- (5) Ensure that the paper is even, and that opposite holes are engaged on the drive pins, and then close the paper gates.

3.5 PRINT WHEEL INSTALLATION

- (1) Release the carriage tilt mechanism by moving the holding lever (1) to the left. Tilt the carriage forward away from the platen.

- (2) Grasp the print wheel by its hub (1). Position it over the drive motor's shaft (3), with its alignment slot (2) lined up with the drive shaft's alignment tab (4).

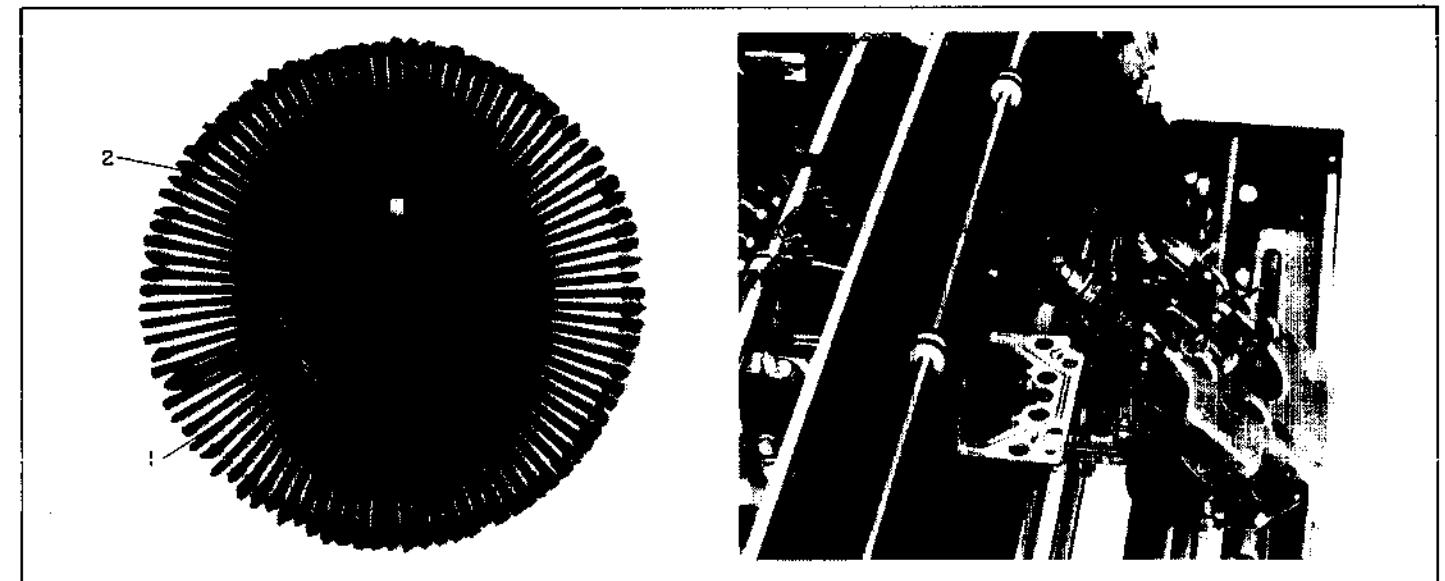

FIGURE 3-7
PRINT WHEEL INSTALLATION — STEP 2

- (3) Press the wheel firmly into place. Tilt the carriage back in to its operating position, and lock it into place by moving the holding lever to the right until it snaps into its detent.
- (4) The print wheel is removed, when the carriage is tilted back, by grasping its hub and pulling it away from the drive shaft.

3.6 RIBBON CARTRIDGE INSTALLATION

- (1) Rotate the manual advance knob on the ribbon cartridge (1) clockwise to tighten the exposed portion of the ribbon.
- (2) Lower the ribbon cartridge into place ("DIABLO" name label UP) over the alignment pins (1) on the carriage platform, with the exposed ribbon between the print wheel and the paper shield (2). Snap the roller clip (3) forward to lock the ribbon cartridge in place.

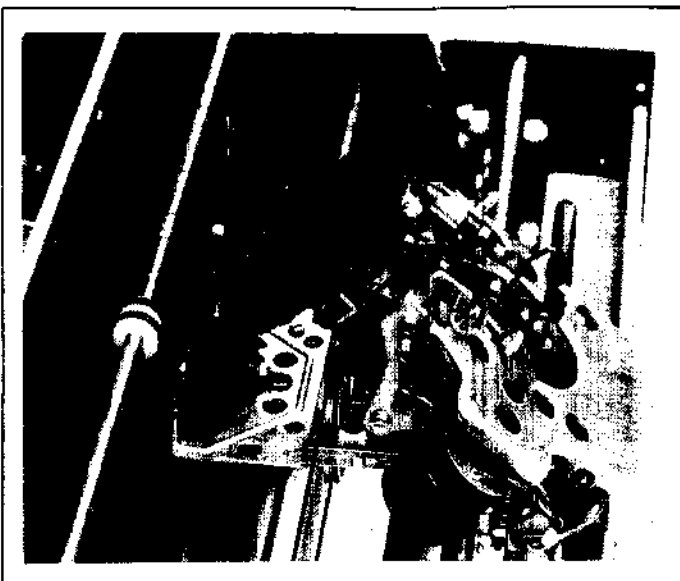

FIGURE 3-8
PRINT WHEEL INSTALLATION — STEP 3

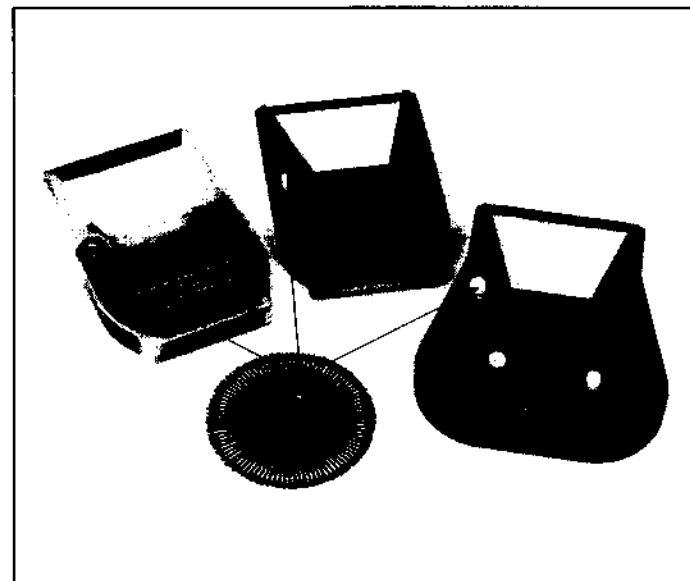

FIGURE 3-9
DIABLO RIBBON CARTRIDGES



FIGURE 3-10
RIBBON CARTRIDGE INSTALLATION

3.7 CLEANING AND MAINTENANCE

- (1) **Cleaning.** Every six months, or oftener if necessary, the interior of the printer should be cleaned. Remove power, lift off the platen and top cover, and remove the ribbon cartridge and print wheel. Carefully clean the interior using a vacuum cleaner (small nozzle) and soft brush. Wipe the carriage rails with a clean dry cloth.
- (2) **Lubrication.** Relubricate the carriage rails with a very light coating of "Molykote 557" (Diablo Part #70658) lubricant. Apply a very small amount of this same lubricant to the print hammer shaft, and manually exercise the hammer to spread the lubricant. Make sure the carriage is tilted forward for this step.
- (3) All other maintenance and lubrication procedures are best left to the service representative.

SECTION 4 INTERFACING

4.1 GENERAL

The following paragraphs contain information on interfacing the HyType I Printer with a system. Included are definitive power requirements, input-output definitions and characteristics, timing parameters, input gates used, and the drive capability of the output lines. The information given here is in addition to the interfacing discussion in Section 1.

4.2 POWER REQUIREMENTS

Figures 4-1 through 4-4 illustrate typical current demands for the +5, +15, and -15 volt power supplies during normal operations with the HyType I Printer. These illustrations are waveforms taken with a Tektronix Model 7403N oscilloscope connected across a 0.1 Ohm 5 Watt 1% wirewound resistor in series with the power supply being measured. Diablo's Model 1329 Power Supply, designed specifically for use with the HyType I Printer, was used for these measurements.

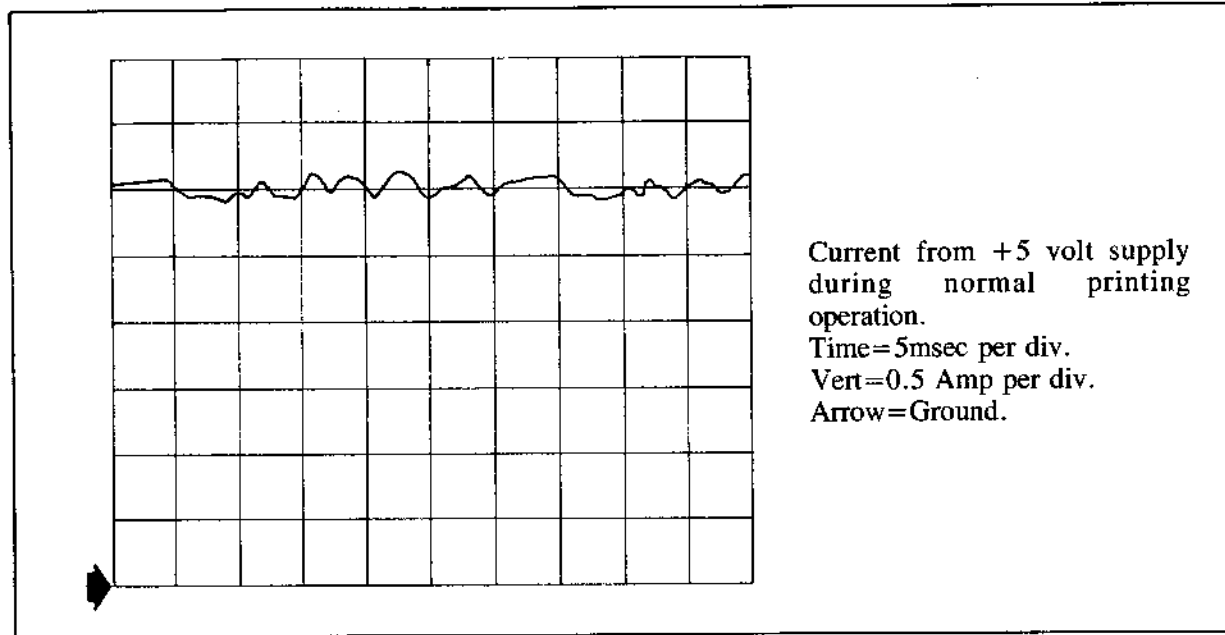

FIGURE 4-1
CURRENT WAVEFORM — +5V

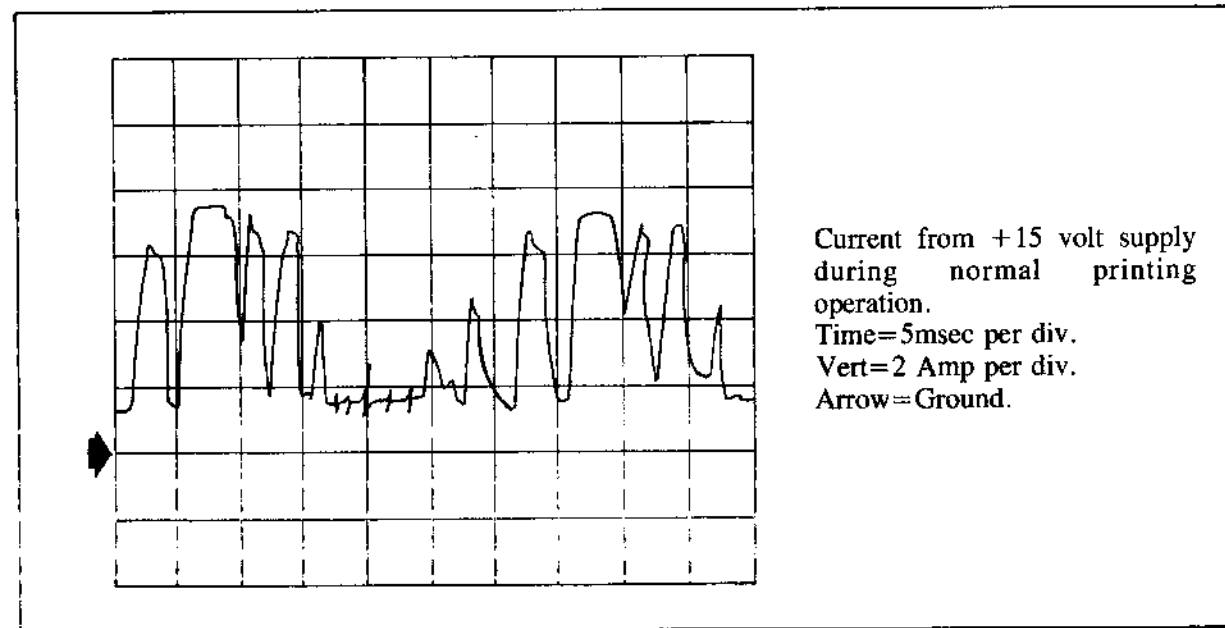

FIGURE 4-2
CURRENT WAVEFORM — +15V

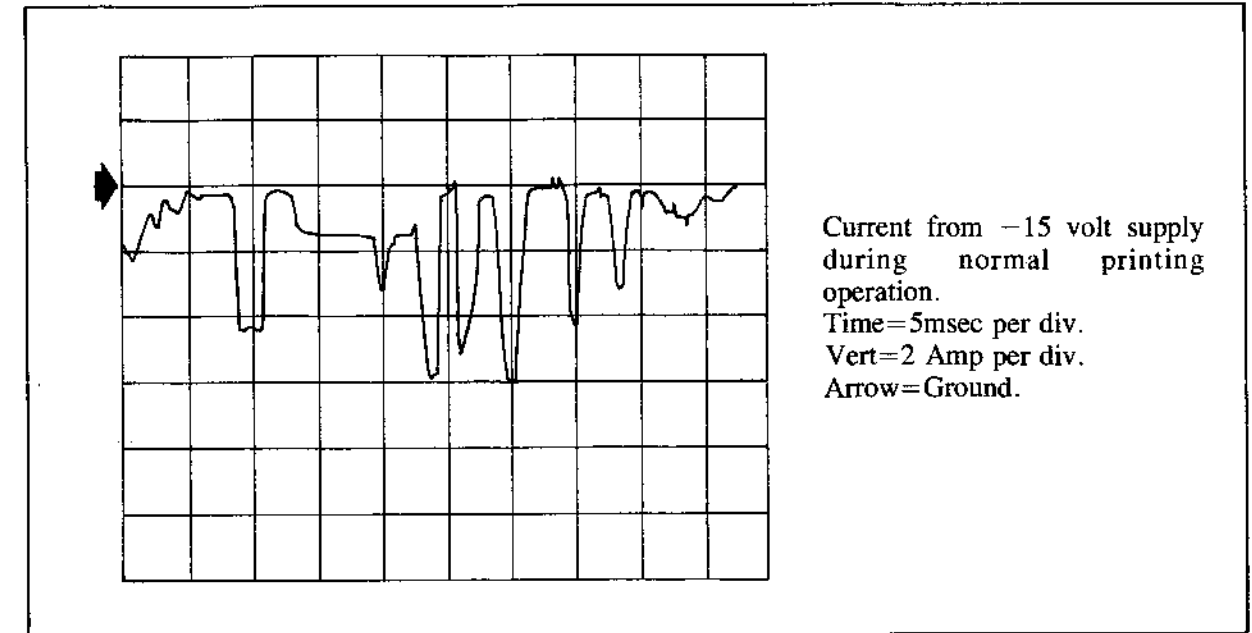

FIGURE 4-3
CURRENT WAVEFORM — -15V (NORMAL OPERATION)

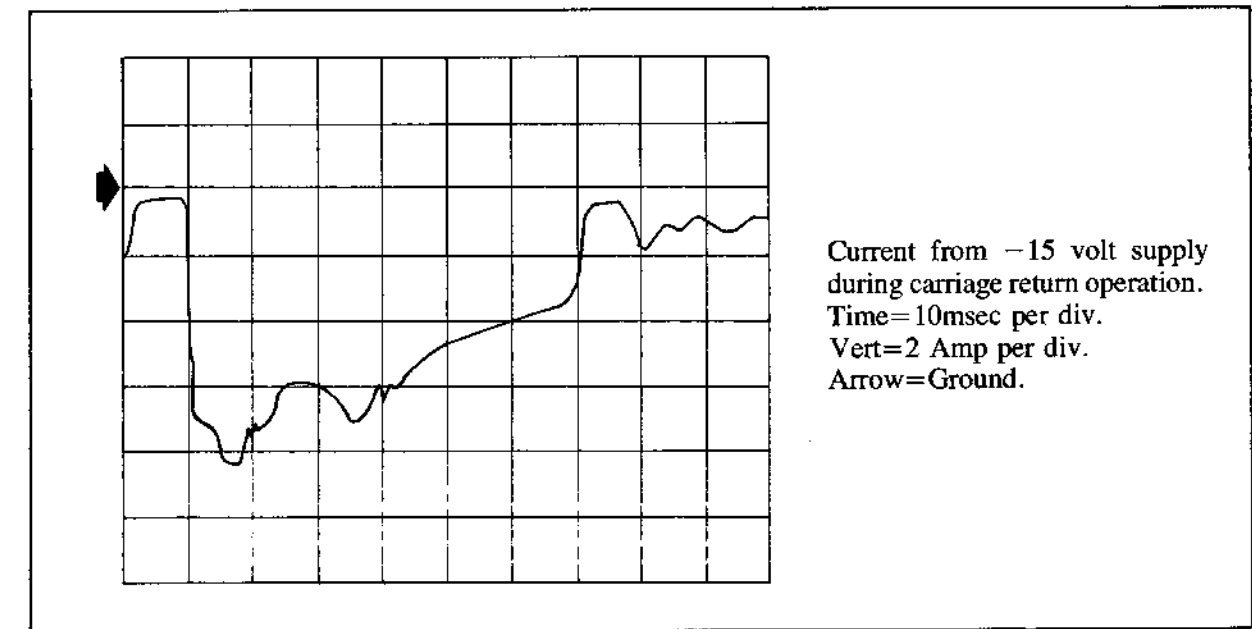

FIGURE 4-4
CURRENT WAVEFORM — -15V (DURING CARRIAGE RETURN)

The current demands illustrated will not be exceeded by more than 10% in any "worst case" situation.

The power connectors used are as follows:

- | | |
|-----------------|---|
| (1) Power Jack: | Winchester #MRAC14PJ6 (Diablo Part #10524-11)
Pin (male) contacts Winchester #100-8114 (Diablo Part #10583-01) |
| (2) Power Plug: | Winchester #MRAC14JTCH (Diablo Part #10534-10)
Socket (female) contacts Winchester #100-0919 (Diablo Part #10525-11) |

4.3 INPUT-OUTPUT DEFINITIONS AND CHARACTERISTICS

SIGNAL NAME	CONNECTOR PIN	SIGNAL NAME	CONNECTOR PIN
-Data 1	h	-Ribbon Lift	M
-Data 2	j	-Printer Ready	a
-Data 4	m	-Check	B
-Data 8	f	-Paper Out	R
-Data 16	k	-Print Check Ready	Y
-Data 32	i	-Carriage Ready	W
-Data 64	g	-Paper Feed Ready	c
-Data 128	d	+External Reset***	L
-Data 256	b	(not used)	Z
-Data 512	V	(not used)	n
-Data 1024	F	Ground	A
-Restore	E	Ground	D
-Print Wheel Strobe	P	Ground	J
-Carriage Strobe	K	Ground	N
-Paper Feed Strobe	C	Ground	T
-Select Printer	S	Ground	U
-Select Ready	H	Ground	X

***Active HI, all other signals active LO

FIGURE 4-5
INPUT-OUTPUT CONNECTIONS

As mentioned in Section 1, signal polarity is a nominal 0Vdc for the LO (or True) condition (0 V minimum, +0.8 V maximum), and +5 Vdc for the HI (or False) condition (+2 V minimum, +5.5 V maximum).

The data cable connectors used are as follows:

- (1) Printer Connector (Jack): Winchester #MRAC34PJ6 (Diablo Part #10668-01), using Pin (male)
Winchester #100-8114 (Diablo Part #10583-01)
- (2) Cable Connector (Plug): Winchester #MRAC34SJTDH (Diablo Part #10669-02) Socket (female)
Winchester #100-09275 (Diablo Part #10525-13) (Part of Kit #20608)

The I/O lines are as follows:

- (1) **Data Lines** — Eleven data lines carry binary coded information into the printer representing an ASCII character, a carriage movement value, or a paper feed movement value. These lines are inhibited until the "Select Printer" input is LO.
When representing an ASCII character, only the low order seven lines (bits) are used. The remaining four lines (bits) are ignored, but should be maintained HI.
When representing a paper feed movement value, the ten low order lines (bits) represent the paper feed distance, in increments of 1/48th of an inch. The eleventh or high order line (bit) determines the direction of paper feed; where 0 = upward movement, and 1 = downward movement.
When representing a carriage movement value, the ten low order lines (bits) represent the carriage movement distance, in increments of 1/60th of an inch. Six increments equal 1 character column at 10 characters or columns per inch, while 5 increments equal 1 character column at 12 characters or columns per inch. The eleventh or high order line (bit) determines the carriage movement direction, where 0 = right movement, and 1 = left movement.
- (2) **Restore** — The Restore command is a signal to the printer to perform a restore sequence. The restore sequence positions the carriage at the first print column, synchronizes the print wheel logic with its position, and conditions registers and flip-flops as necessary for a starting situation. This command is normally inhibited until the "Select Printer" input is LO, but can be initiated by a momentary loss (or removal) of power.
- (3) **Print Wheel Strobe** — The Character Strobe command is a signal used to gate, or load, the contents of the incoming

data lines into the print wheel buffer register, to start the character select and print sequence. This command is inhibited until the "Select Printer" input is LO.

- (4) **Carriage Strobe** — The Carriage Strobe command is a signal used to gate, or load, the contents of the incoming data lines into the carriage buffer register, to start the carriage movement sequence. This command is inhibited until the "Select Printer" input is LO.
- (5) **Paper Feed Strobe** — The Paper Feed Strobe command is a signal used to gate, or load, the contents of the incoming data lines into the paper feed buffer register, to start the paper feed sequence. This command is inhibited until the "Select Printer" input is LO.
- (6) **Select Printer** — The Select Printer command is a signal generated by the controller to select, or enable, a specific printer in a multiprinter system. This signal enables all interface lines except "Select Ready." It must be supplied by the controller even in those systems where there is only one printer.
- (7) **Select Ready** — The Select Ready command is a "status of printer" inquiry signal. It enables Character, Carriage, and Print Wheel Ready lines only, to allow the controller to "read" these three for printer status only. This command overrides the Select Printer command.
- (8) **Ribbon Lift** — The Ribbon Lift command is a signal used to initiate the ribbon cartridge tilt sequence, to enable the printer to print the primary (black) ribbon color, when using the two-color ribbon. When this signal is HI, the ribbon stays in its low position, the printer prints in the secondary (red) ribbon color.
- (9) **External Reset** — This input is normally used only by the Test Exerciser for test purposes.
- (10) **Printer Ready** — This signal, when LO, indicates that the printer has been selected, and that power has been properly applied.
- (11) **Check** — This signal, when LO, indicates that the carriage failed to properly complete a carriage movement command, and that the carriage drive circuits have been inhibited. This signal inhibits all data input, ready status, and strobe lines. It is removed by a restore sequence.
- (12) **Paper Out** — This signal, generated by a user supplied sensor, is processed through the printer's circuits the same as other outputs.
- (13) **Print Wheel Ready** — This signal, when LO, indicates that the printer's circuits are ready to receive and execute print wheel movement commands.
- (14) **Carriage Ready** — This signal, when LO, indicates that the printer's circuits are ready to receive and execute carriage movement commands.
- (15) **Paper Feed Ready** — This signal, when LO, indicates that the printer's circuits are ready to receive and execute paper feed commands.

4.4 INPUT SIGNAL CHARACTERISTICS AND SEQUENCE CONSIDERATIONS

4.4.1 Signal Characteristics

The controller should provide the following signals to the printer. All should be negative going square waves free of spikes, overshoot, and ringing. The 0 V level represents the LO (or True) condition, and the +5 V level represents the HI (or False) condition.

- (1) **Data** — signals (pulses) should be 1.4 μ sec minimum duration.
- (2) The **Select Printer** signal should be a steady state LO condition returning to the HI state when the printer is no longer selected by its controller. This signal must have a minimum duration of 1.4 μ sec for a single character. Ideally, the signal should remain LO as long as the printer is in use.
- (3) The **Select Ready** signal should be 0.4 μ sec minimum duration.
- (4) The **Restore**, **Strobe**, and **External Reset** signals should all be 1.0 μ sec minimum duration.
- (5) The **Ribbon Lift** signal is to be 64 msec minimum duration.

4.4.2 Signal Sequencing

Under normal operation, the printer automatically initiates a Restore sequence whenever power is applied. Upon completion of this sequence (approximately 4 seconds), the printer generates *Printer Ready* = LO, *Printer Wheel Ready* = LO, *Carriage Ready* = LO, and *Paper Feed Ready* = LO signals. When enabled by a Select Printer signal from the controller, these signals should enable the controller to supply operational data and commands to the printer.

In those systems making use of more than one printer, the system can select a single printer for immediate use. In this

event, the system may be programmed to query each printer on its status, through the Select Ready system. This signal (Select Ready) enables the printer to immediately transmit its Print Wheel Ready, Carriage Ready, and Paper Feed Ready = LO signals.

The controller activates the printer by supplying it with a Select Printer = LO signal. This signal enables all printer input and output lines. As mentioned above, it should remain LO as long as the printer remains active. Upon receipt of a Select Printer = LO, the printer logic immediately transmits the several ready = LO signals.

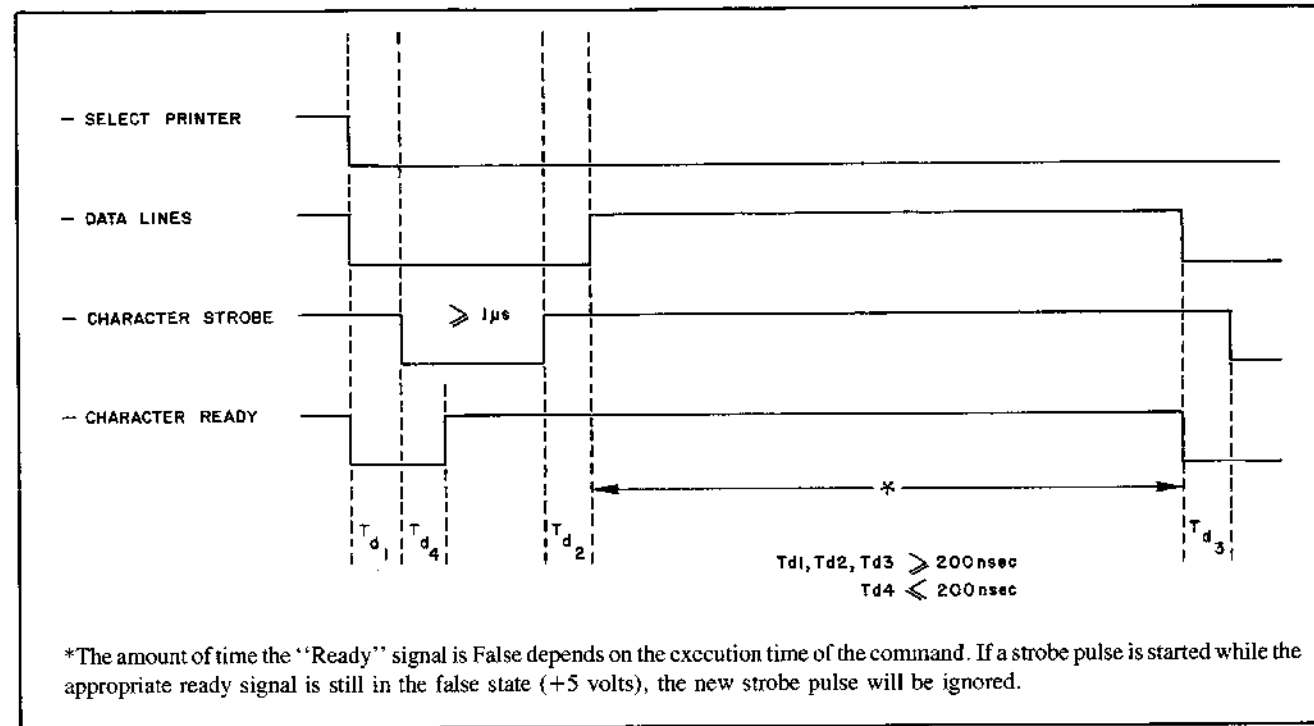

FIGURE 4-6
TYPICAL COMMAND SEQUENCE

The timing diagram in Figure 4-6 illustrates a typical command sequence. With the Select Printer input = LO, and the appropriate ready signals = LO also, the printer can receive movement data and commands from the controller:

- (1) The controller places the movement data on the data lines.
- (2) The strobe signal gates (loads) the data into the appropriate buffer register, and starts the sequence to execute the command.
- (3) The appropriate ready signal goes HI within 200 nsec following the leading edge of the strobe signal, and will remain HI until the commanded sequence has been completed.

Commands for printing a character, moving the carriage, and moving the paper can be overlapped to a minimum of 400 nsec separation between strobe signals, and the printer will execute the commands in the order received. Carriage motion, paper feed motion, and print wheel motion, while otherwise compatible for simultaneous execution, will all be inhibited during the "print hammer" portion of the character print sequence. This sequence, or cycle, is divided into two sub-cycles:

- (1) Print Wheel motion to align the selected character, and
- (2) Print hammer firing.

Conversely, print hammer firing will be inhibited if any one of the other activities is in progress.

A Carriage Strobe followed by a Character Strobe will cause both the carriage and the print wheel to move. Printing will occur only, however, when both the carriage and the print wheel are fully stopped. This is a "space before print" sequence.

A Character Strobe followed by a Carriage Strobe will first cause the print wheel to rotate and the character to be printed, prior to carriage motion. This is a "space after print" sequence.

The time involved along a print line is the same for the two types of sequence because, after the first character has been printed, movement is overlapped.

The controller is required to keep track of the carriage location for correctly returning the carriage to the start position. The Restore line should not be used as a carriage return command. Knowing the incremental address of the carriage allows the system to correctly return the carriage to a new start position, as well as determining how much of the print line is remaining.

4.5 INPUT GATES

The HyType I Printer makes use of a 8836 type NOR-Gate as the input circuit. This integrated circuit is from the unilogic family and, because of its circuit structure, has a higher input threshold in the "low" logic state than most commercially available DTL or TTL circuits. This assures a higher noise margin on all input lines.

The input of the 8836 circuit has to be "pulled up" to the "high" logic state. For this reason, it cannot be driven by an open collector driver without collector resistance. The collector resistance inside the printer, as shown in Figure 4-7, is 150 Ohms.

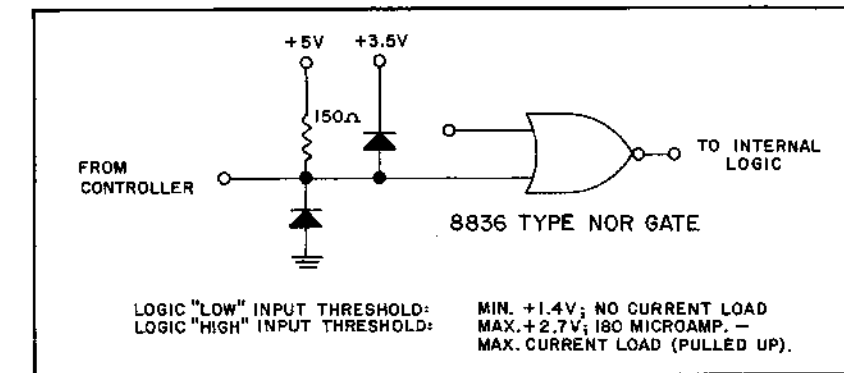

FIGURE 4-7
TYPICAL INPUT CIRCUIT

4.6 DRIVE CAPABILITY OF OUTPUT LINES

The open collector circuit shown in Figure 4-8 is used to drive the output lines to the using system.

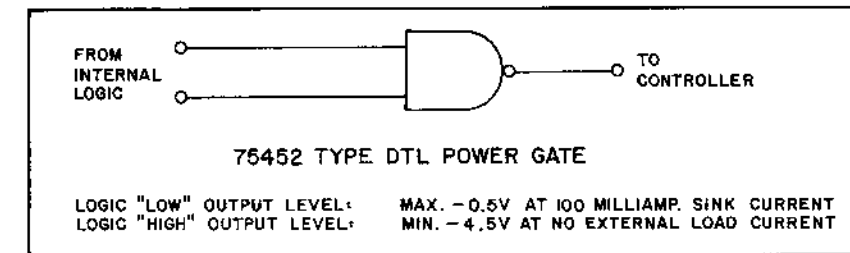

FIGURE 4-8
TYPICAL OUTPUT CIRCUIT

SECTION 5 PRINCIPLES OF OPERATION

5.1 GENERAL

The Diablo Model 1200 series HyType I Printer makes use of some unique electronic control techniques in its operation. This reduces its dependence on mechanical devices, and produces a smoother, faster, and more reliable unit. The greater part of this section is, therefore, devoted to detailed discussions of the printer's electronic circuits. The mechanical details are left for discussion at the end of the section.

For purpose of clarity, and ease of translation between systems, reference herein to the various signals and/or logic gates will be terms of the *voltage level* involved. LO will indicate a circuit nominal voltage level of 0 Vdc, and HI will indicate nominal voltage level of +5 Vdc.

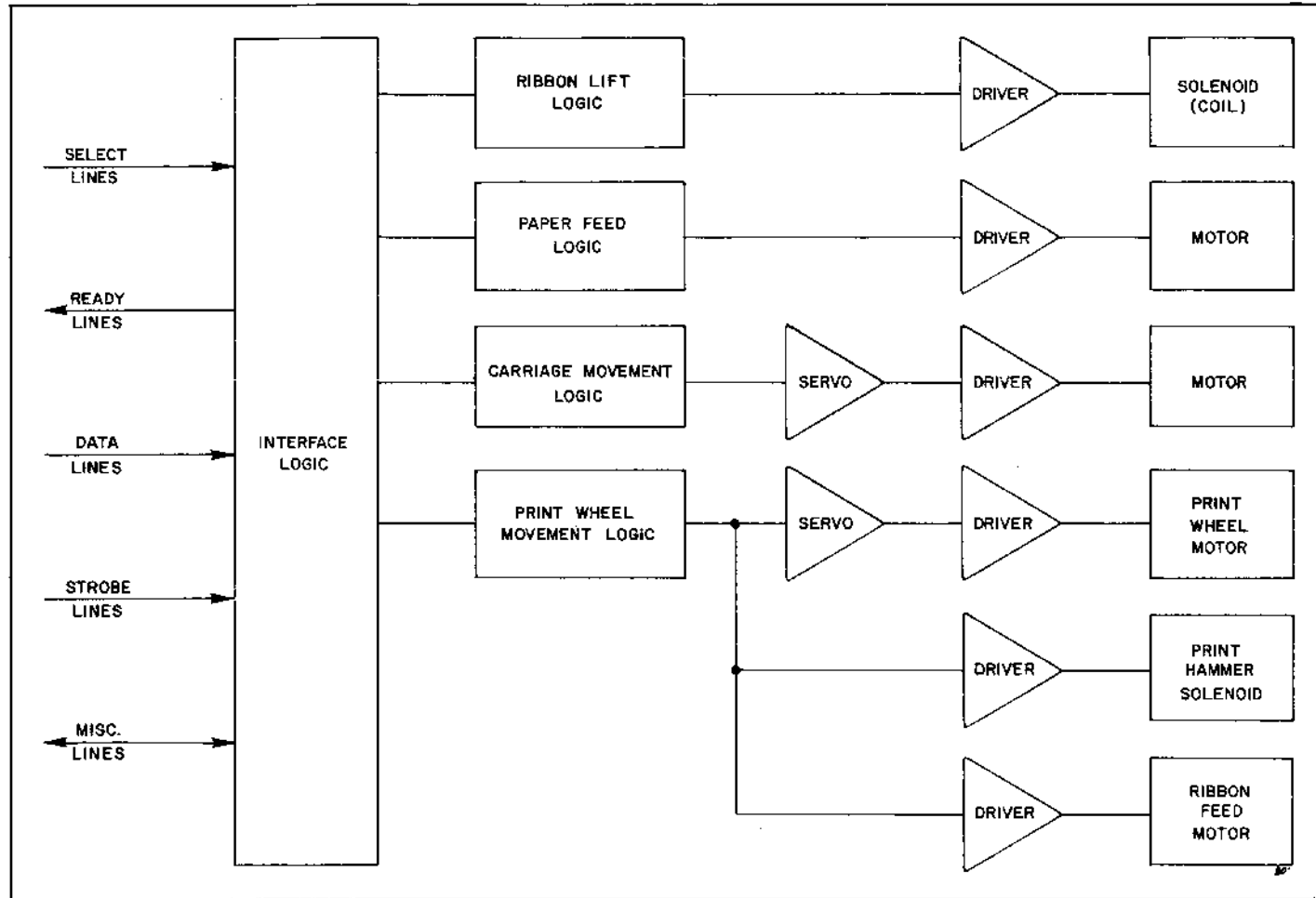

FIGURE 5-1
SIMPLIFIED BLOCK DIAGRAM — HYTYPE I PRINTER

5.2 BLOCK DIAGRAM

The HyType I Printer consists of four major functional divisions, as illustrated in Figure 5-1. The four divisions, or major circuits, control a total of six operating functions. These are: *Ribbon Lift*, *Paper Feed*, *Carriage Movement*, *Print Wheel Movement*, *Print Hammer Action*, and *Ribbon Feed*. In addition, there are three more functions not shown in the block diagram. Two of these, *Restore* and *Check*, are to be considered as involving printer self-management. The third, *Out-of-Paper*, is a user convenience feature to provide a user supplied paper sensor with a signal channel to the system through the printer cabling.

In the following paragraphs, all nine functions will be discussed separately. Sub-section 5.11 will then discuss the interaction of these nine functions.

5.3 POWER ON VOLTAGE MONITOR

The proper supply of power to the HyType I Printer is very important. The loss or impairment of any one of the three voltages required will prevent correct operation of the printer. Figures 5-2 Block Diagram, and 5-3 Circuit Diagram, describe

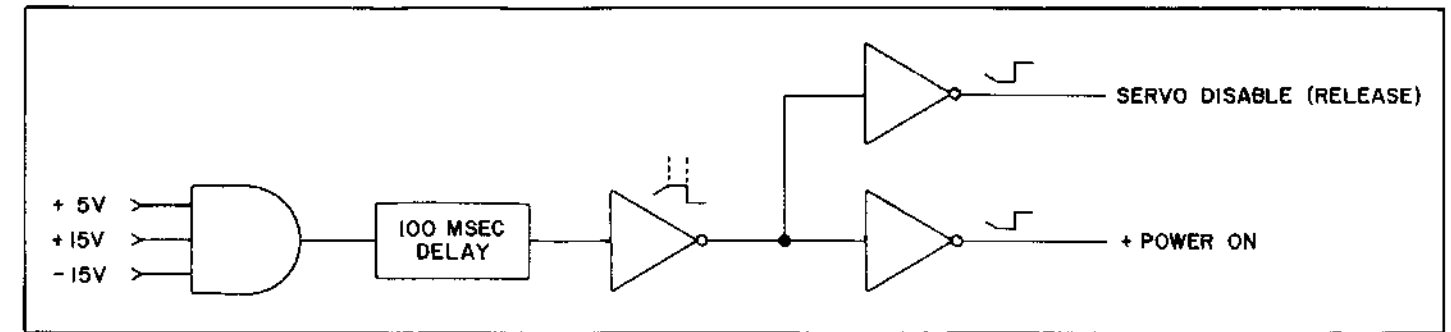

FIGURE 5-2
BLOCK DIAGRAM — VOLTAGE MONITOR

the Voltage Monitor circuit operation, while Figure 5-4 locates the circuit components on the printer's rear panel, or *Combo* circuit board.

5.3.1 Block Diagram

The purpose of the Voltage Monitor circuit is to inhibit paper feed, print wheel and carriage movement servo operation to protect their circuits, inhibit all "ready" gates to the controller to prevent initiation of printer activity by the using system, and to initiate a printer restore sequence.

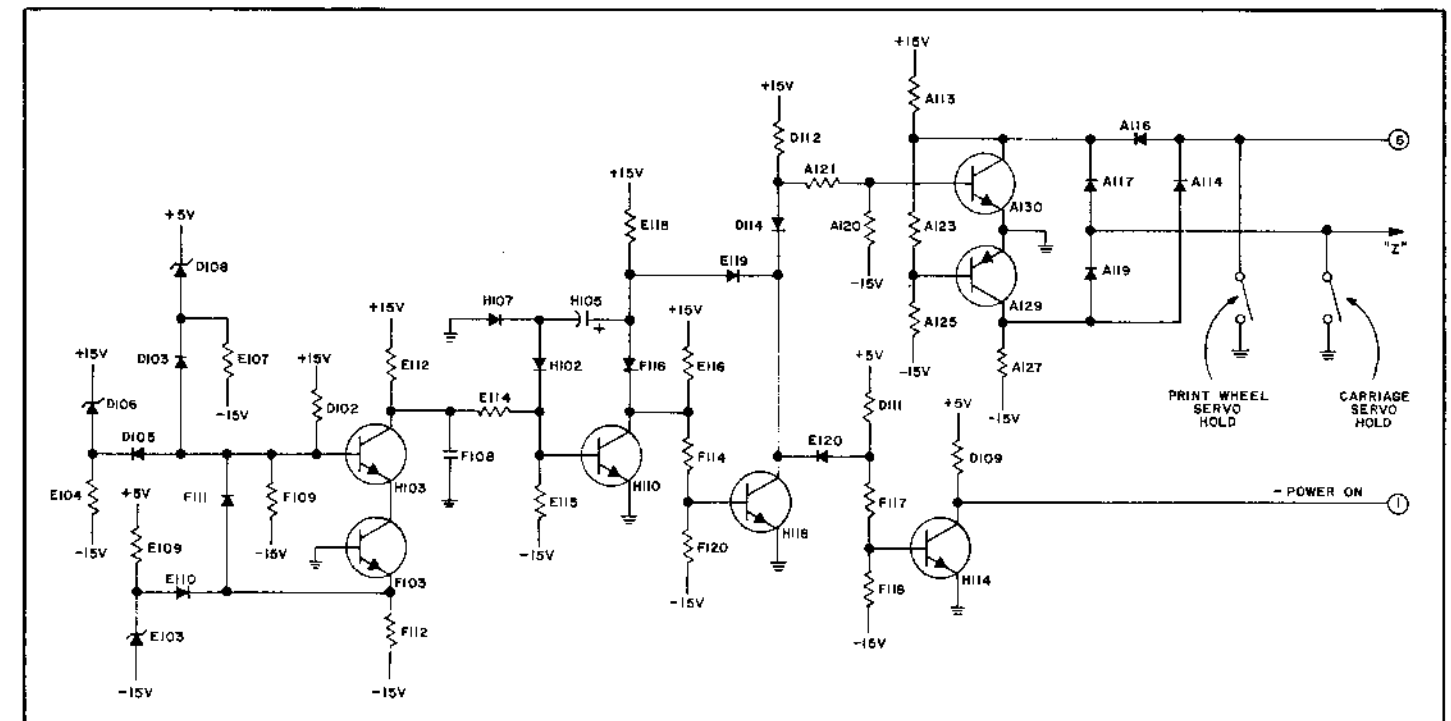

FIGURE 5-3
CIRCUIT DIAGRAM — VOLTAGE MONITOR

5.3.2 Theory of Operation

As power is turned on, transistors H103 and F103 are *off*, and the base of H103 takes a negative value. Three divider networks begin to sample the voltage levels being supplied: zener diode D108 and resistor E107 sample the +5 volt input; zener diode D106 and resistor E104 sample the +15 volt input; the zener diode E103 and resistor E109 sample the -15 volt input. As these voltages approach their full value, diodes D103, D105, E110, and F111 (operating as an AND circuit) are reversed biased, the base of transistor H103 takes on a slightly positive value, and transistors H103 and F103 turn *on*. To this point, transistor H110 had been *on*. When transistor H103 turns *on*, transistor H110 turns *off*, and capacitor H105 begins to charge. The RC time constant for capacitor H105 and resistor E118 is 100 msec. With transistor H118 *off*, transistors H114, A129, and A130 are all biased *on*, clamping their outputs LO. This condition disables the printer's servo and Paper Feed circuits.

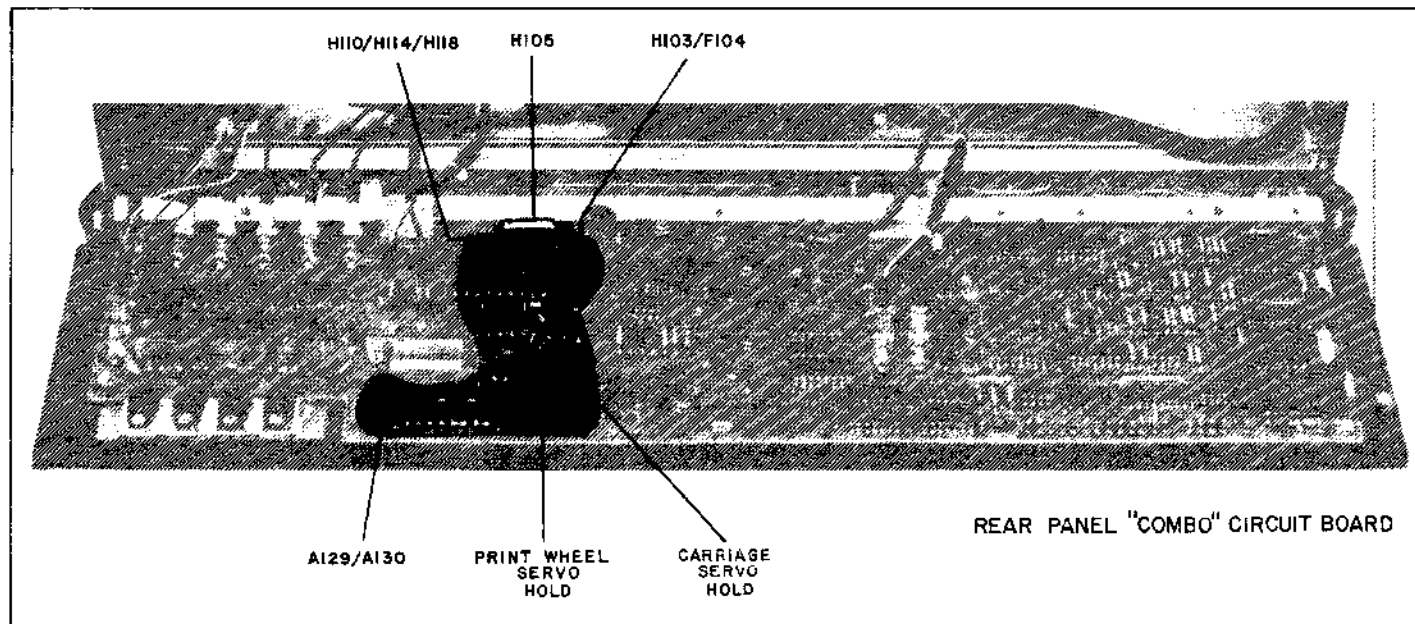

FIGURE 5-4
COMPONENT LOCATIONS — VOLTAGE MONITOR CIRCUIT

At the end of the 100 msec charging time of H105, transistor H118 is biased *on*, turning transistors H114, A129, and A130 *off*. This removes the servo clamps, and allows the +5 POWER ON circuit to assume its HI, state. The +5 POWER ON, in going HI causes the initiation of the Restore sequence.

Any subsequent interruption in, or depreciation of, any of the three voltage inputs will unbalance the Voltage Monitor's input AND circuit, turn transistors H103 and F103 *off*, and turn transistor H110 *on* to discharge capacitor H105. This action resets the Voltage Monitor, and clamps the outputs LO. Complete restoration of power re-initiates the 100 msec delay, and initiates a Restore sequence.

5.4 CHECK FUNCTION AND SEQUENCE

5.4.1 Function

The function of the Check circuit is to protect the printer from damage in the event of a carriage malfunction or jam-up. The block diagram in Figure 5-5 describes the Check circuit's operation, and Figure 5-6 locates the circuit components.

The Check circuit centers around a D type flip-flop. An input from the *carriage motion timer* circuit is used to "clock" the flip-flop, while the *carriage velocity enable* circuit supplies the "data" input. Inputs from the +POWER ON and -RESTORE COMMAND lines are used to control the flip-flop's "clear" or reset condition.

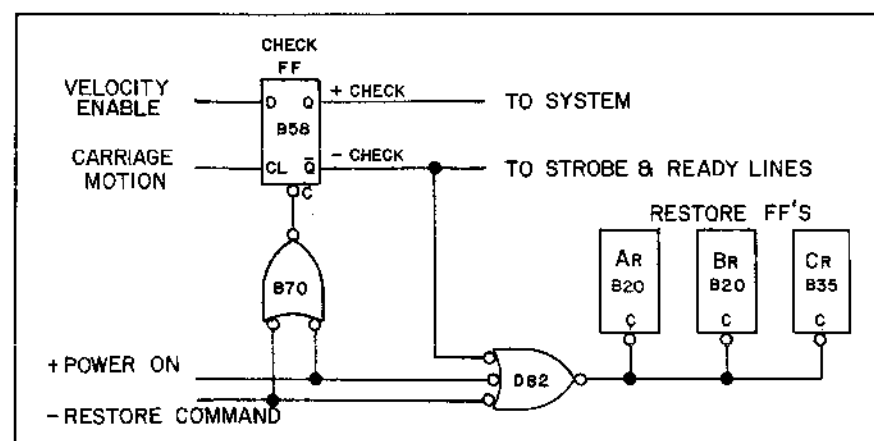

FIGURE 5-5
CIRCUIT DIAGRAM — CHECK

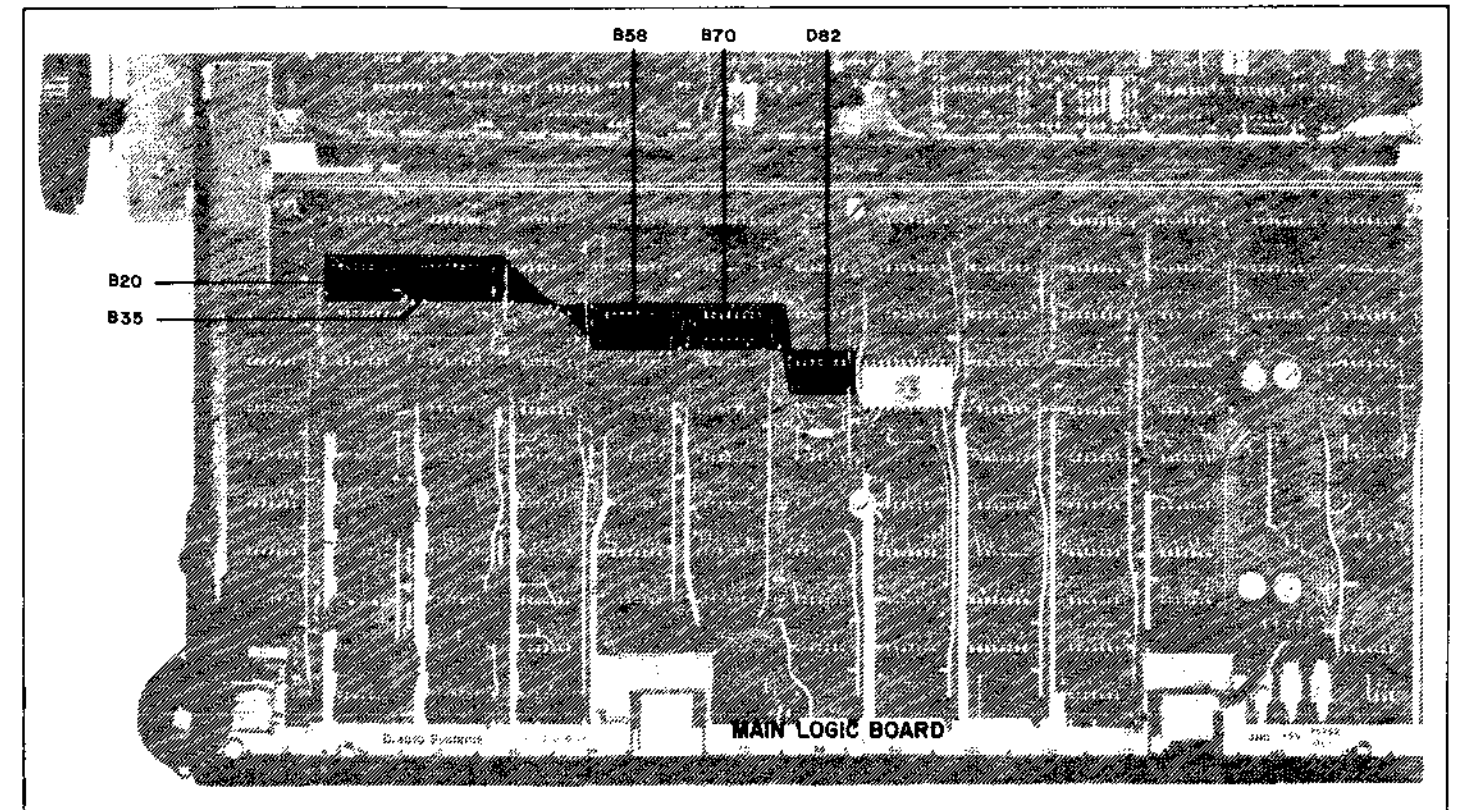

FIGURE 5-6
COMPONENT LOCATIONS — CHECK CIRCUIT

In operation under normal circumstances, the following conditions are present when a carriage movement command has been received:

- (1) The Check flip-flop's outputs are in their *Reset* states.
- (2) The velocity enable input (D), and the +POWER ON/-RESTORE COMMAND input are both HI.
- (3) The *carriage motion* input (CLK) is LO.

5.4.2 Sequence

The Check flip-flop outputs will change state, to $Q=HI/\bar{Q}=LO$, anytime the carriage is unable to complete a movement command, or is unable to move fast enough.

With a carriage movement command being acted upon, Check FF-D=HI enables carriage movement as long as the carriage has not reached the commanded position.

As soon as a carriage movement command (strobe) is received, the *carriage motion timer* (32 msec) begins to run. As the carriage moves, a pulse is generated for every 1/60th of an inch increment of movement. Each such pulse resets the timer, which begins to time out again. Should the carriage either move too slowly, or fail to move at all, a reset pulse will not be generated in time, and the *carriage motion timer* will time out. Its output, which is also Check FF-CLK, will go HI.

When Check FF-CLK=HI, the state of Check FF-D transfers to Q, and Check FF-Q (+Check)= HI/\bar{Q} (-Check)=LO, and the flip-flop has assumed its tripped, or *set* state ($Q=HI/\bar{Q}=LO$).

The Check FF state of $Q=HI/\bar{Q}=LO$ places the printer's operation in the *check* mode. This disables all "ready" and "strobe" lines, and also places the Restore FF's in their *force reset* condition, which disables the printer's logic.

5.5 RESTORE FUNCTION AND SEQUENCE

5.5.1 Function

The function of the Restore circuit is to provide a series of controlling signals to the printer logic in proper sequence. These signals cause the printer functions to become conditioned for an initial start situation. This conditioning includes positioning of the carriage, synchronizing the print wheel logic to wheel position, clearing the registers, and resetting the logic. The diagram in Figure 5-7 describes the circuit, while Figure 5-8 locates the restore circuit components. Figure 5-9 illustrates the timing waveforms for the basic restore circuit.

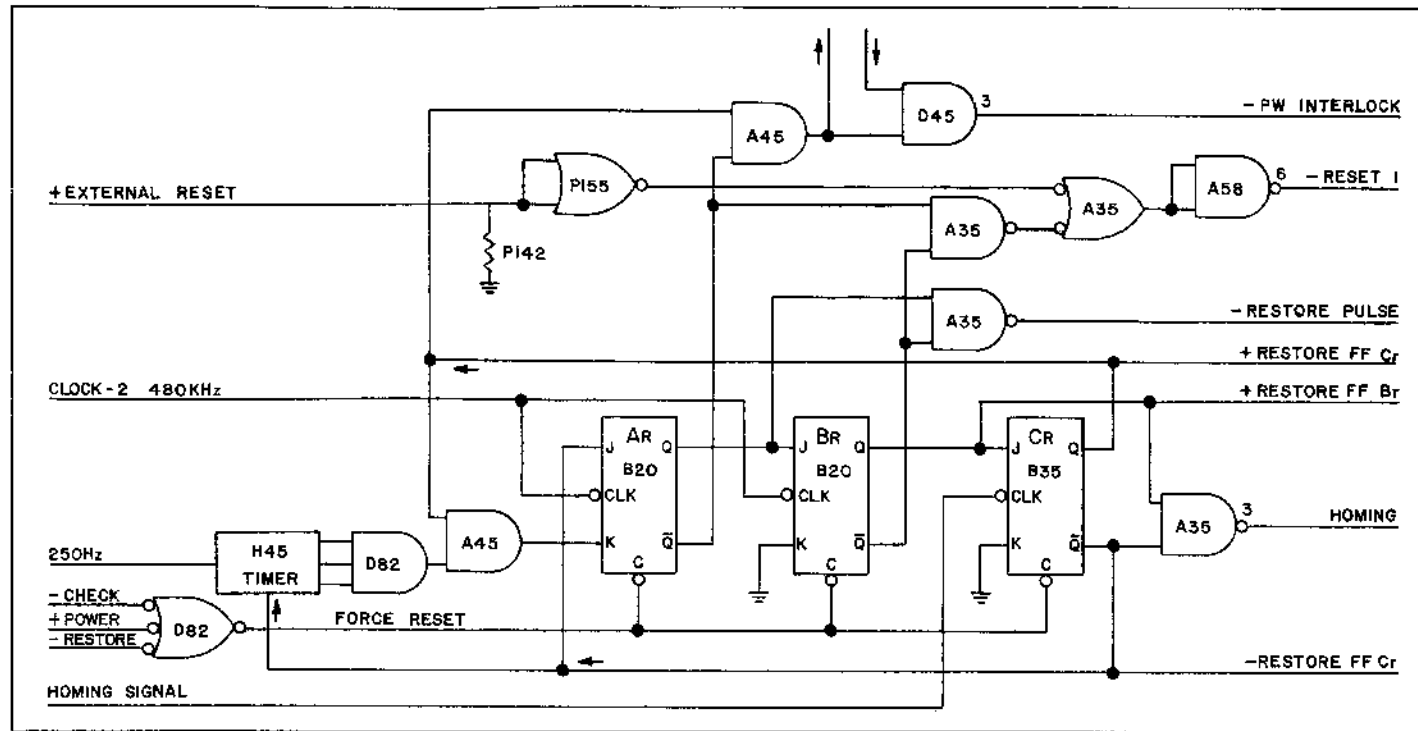

FIGURE 5-7
CIRCUIT DIAGRAM — RESTORE

5.5.2 Sequence

The Restore circuit control logic consists of three J-K type flip-flops Ar, Br, and Cr, a 56 msec timer (4-bit ripple counter) which provides a delay function, and a series of controlling gates for the several output signals.

In operation under normal circumstances, all three Restore flip-flops are in their *set* state of $Q=HI/\bar{Q}=LO$. Due to its internal design, FF Ar-J=LO will not cause a change in output at this time. The restore sequence is initiated by a LO on the

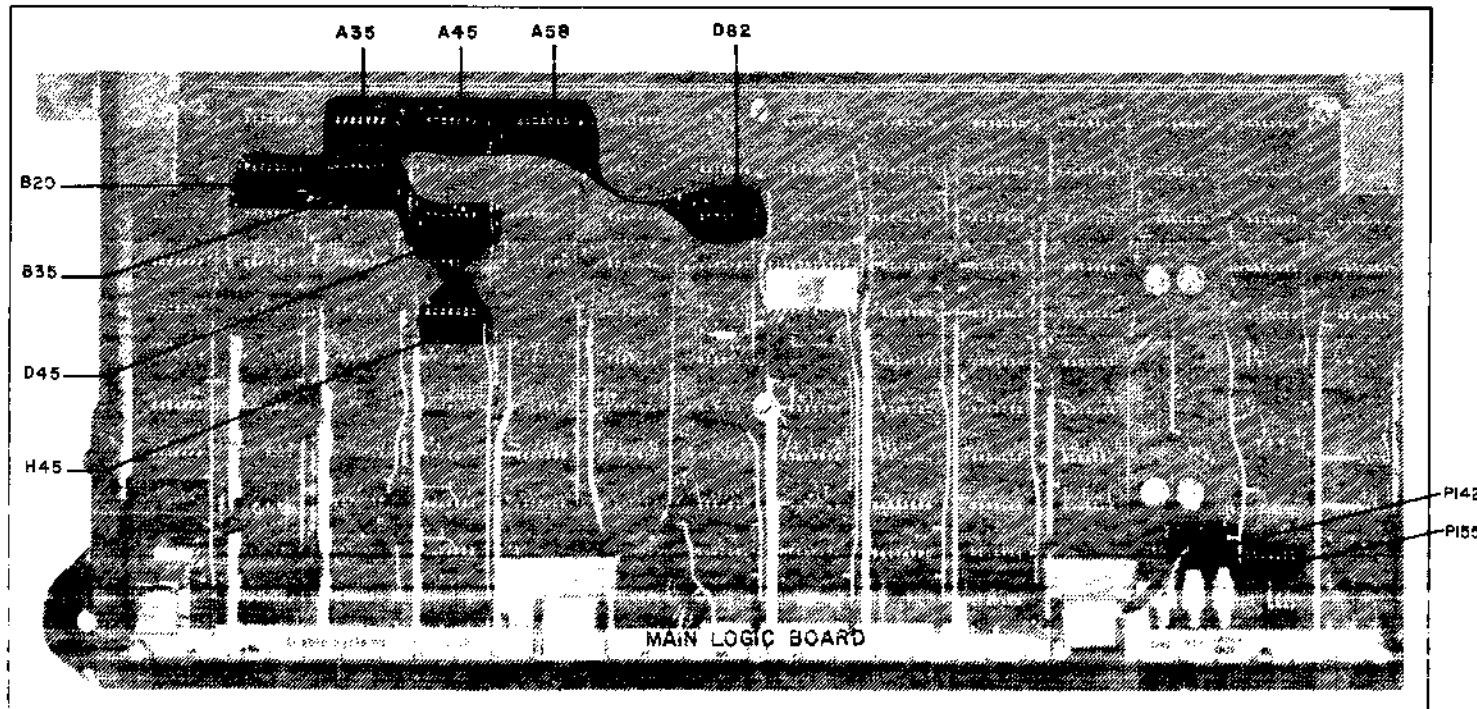

FIGURE 5-8
COMPONENT LOCATIONS — RESTORE CIRCUIT

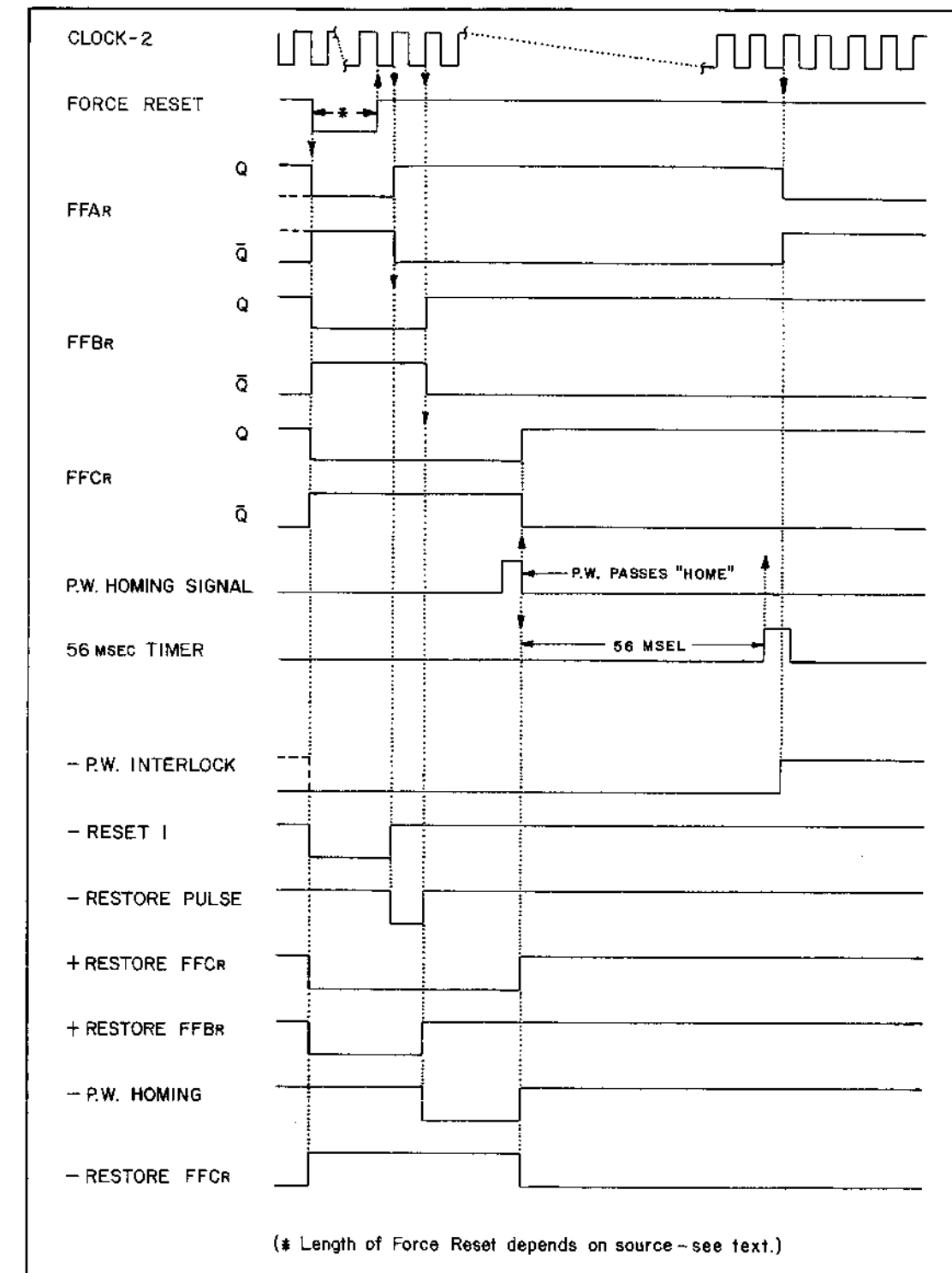

FIGURE 5-9
TIMING WAVEFORMS — RESTORE CIRCUIT

Force Reset line to all three FF's (Ar, Br, and Cr). Note that the Force Reset LO is the result of a LO on any one or all three of its sources: the -RESTORE COMMAND, which will be at least 1 msec duration; the +POWER ON signal of at least 100 msec duration; or the -CHECK signal which is a condition of indefinite duration, requiring an input from -RESTORE COMMAND or +POWER ON to its flip-flop to clear. See Section 5.4.

The Force Reset LO resets all three flip-flops to $Q=LO/\bar{Q}=HI$. Removal of the Force Reset LO restores the flip-flops to clock control. The first negative CLOCK-2 pulse following Force Reset=HI allows FF Ar to set $Q=HI/\bar{Q}=LO$. The second negative CLOCK-2 pulse allows FF Br to set $Q=HI/\bar{Q}=LO$ also. FF Cr holds its reset condition of $Q=LO/\bar{Q}=HI$. Some

time later, a Print Wheel Sync Pulse HI will be applied to FF Cr-CLK, and FF Cr sets $Q=HI/\bar{Q}=LO$. FF Cr- $\bar{Q}=LO$ allows the 56 msec timer to run, its internal J-K flip-flop counters having been held in their reset state by FF Cr- $\bar{Q}=HI$. When the timer times out, it places a HI on FF Ar-K. The next negative CLOCK-2 pulse resets FF Ar to $Q=LO/\bar{Q}=HI$. Since both FF Ar and FF Br now have $J=LO/K=LO$, further Print Wheel (PW) Sync Pulses will not alter their state. These three Restore flip-flops will thus remain in the states of FF Ar $Q=LO/\bar{Q}=HI$, and FF Br/Cr $Q=HI/\bar{Q}=LO$ until the next occurrence of a Force Reset LO.

The -PW INTERLOCK signal is derived from FF Ar- \bar{Q} and FF Cr-Q, ANDed together and then NORed with a signal from the print wheel control logic. It goes LO when the RESTORE flip-flops are initially reset, and remains LO until the end of the Restore sequence, when FF Ar is reset by the 56 msec timer.

The -RESET 1 signal is derived from FF Ar- \bar{Q} and FF Br- \bar{Q} NANDed together. It goes LO when the Restore flip-flops are initially reset ($\bar{Q}=HI$ on both), and remains LO until FF Ar sets on the next CLOCK-2 pulse following removal of the Force Reset LO. An external Reset signal will force -RESET 1 LO, overriding the Restore flip-flops.

The -RESTORE PULSE signal is derived from FF Ar-Q, and FF Br- \bar{Q} NANDed together. It goes LO for one CLOCK-2 pulse between the time when FF Ar sets following the end of Reset, and when FF Br sets one CLOCK-2 pulse later.

The \pm RESTORE FF Br and Cr signals reflect the status of their respective flip-flops.

The -PRINT WHEEL HOMING signal is derived from FF Br-Q and FF Cr- \bar{Q} NANDed together. It goes LO when FF Br sets, and remains LO until FF Cr is clocked and set by the + HOMING SIGNAL.

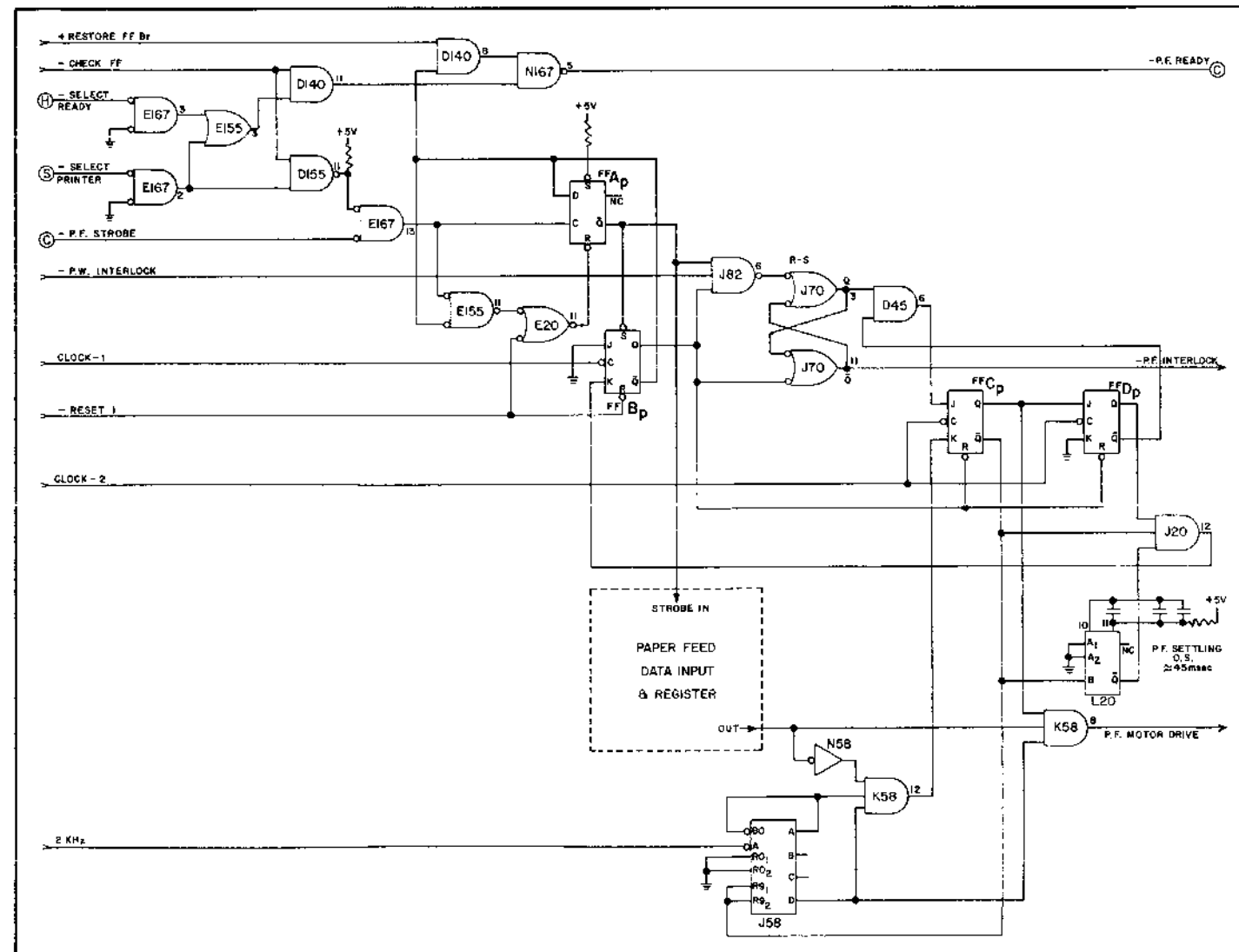

FIGURE 5-10A
CIRCUIT DIAGRAM — PAPER FEED CONTROL LOGIC

The effect that these various signals have on the printer logic will be included in the discussion of each circuit of when they appear.

5.6 PAPER FEED FUNCTION AND SEQUENCE

5.6.1 Function

The function of the Paper Feed circuit is to control the movement, or feeding, of paper through the printer. Paper movement is controlled in both distance and direction, as specified by the controller. The circuit diagrams in Figures 5-10A-C describe the three parts of the circuit, and Figures 5-11A-C show the location of the components for each part.

5.6.2 Sequence

The Paper Feed circuit can be separated into three parts; control logic, data input, and feed motor drive circuits.

The control logic sub-circuit is described in Figure 5-10A, and its components may be located by referring to Figure 5-11A. Its purpose is to:

- (1) Receive a SELECT READY or SELECT PRINTER signal from the controller, and respond with a PAPER FEED READY signal if the paper feed circuit is in fact ready to receive and process commands;
- (2) Receive the paper feed commands, and initiate movement;
- (3) Issue signals to the controller signifying movement in process and/or movement completed;
- (4) Generate a 5 msec pulse train output for use in the feed motor drive circuit;
- (5) Produce an interlock signal to inhibit hammer fire action in the print wheel section while the paper is in motion;
- (6) Inhibit its own paper feed movement during the hammer fire portion of a previously initiated print wheel movement sequence;
- (7) Disable its operation, and reset its logic, upon receipt of a Restore or a Check signal; and
- (8) To Reset its logic and issue a PAPER FEED READY signal when paper feed movement has been completed.

Operation of the paper feed control logic circuit is as follows:

- (1) Starting in a quiescent state, all flip-flops are in reset condition, that is $Q=LO/\bar{Q}=HI$, and all inputs are HI except the 2 KHz and the CLOCK-1/2 inputs. The PAPER FEED READY and PAPER FEED INTERLOCK outputs are both HI, and the motor drive output is LO.
- (2) A -SELECT READY=LO, applied to NOR gate E167-3, is inverted and passed through OR gate E155-3 to AND gate D140-11, where it is compared with the -CHECK status. If both are HI, a HI will be passed to NAND gate

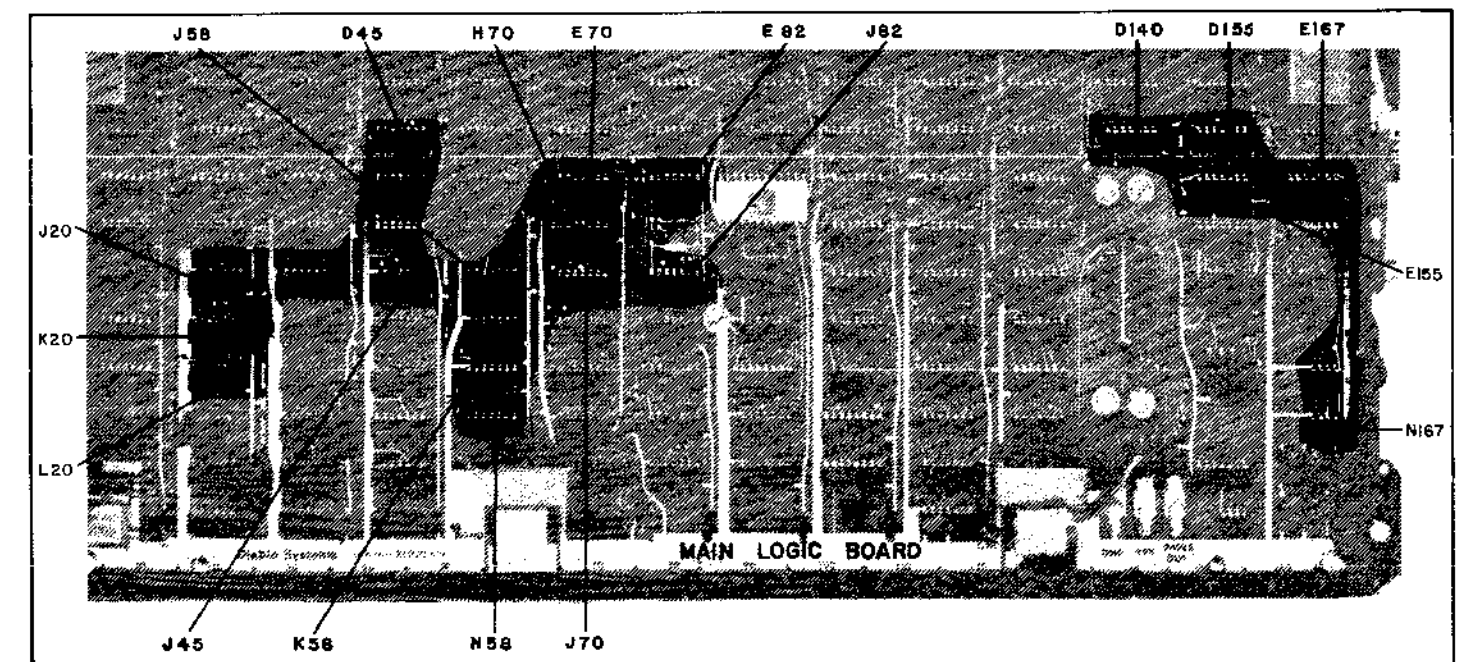

FIGURE 5-11A
COMPONENT LOCATIONS — PAPER FEED CONTROL LOGIC CIRCUIT

N167-5. AND gate D140-8 also supplies a signal, +RESTORE FF Br, to N167-5. D140-8 compares +RESTORE FF Br status and the \bar{Q} reset status of FF Bp. If both are HI, indicating that the control logic is reset, and that the printer is not in a restore cycle, a HI will be passed to N167-5. N167-5 will invert the HI inputs, and place a LO on its output, which is the -PAPER FEED READY line, and where a LO status indicates that the paper feed section is ready to receive and execute paper feed commands.

The -SELECT READY=LO signal is a pulse, sent by the controller to interrogate the printer. Upon its removal, the circuit returns to its quiescent state, and the -PAPER FEED READY line returns to its HI state.

- (3) The -SELECT PRINTER signal, when LO, enables the printer's circuits to respond to commands from the controller. -SELECT PRINTER=LO is applied to NOR gate E167-2, where it is inverted and applied to OR gate E155-3, and to NAND gate D155-11. From E155-3 the signal follows the same sequence as the -SELECT READY=LO signal, to produce the -PAPER FEED READY=LO status. At D155-11, it is compared with the -CHECK FF status. If both are HI (printer is not in Check), a LO is passed to NOR gate E167-13. E167-13 is then enabled, and the paper feed logic is ready to receive commands.
- (4) The controller, having received the -PAPER FEED READY = LO signal, places paper feed direction and distance data on the data input lines. The controller then may place a LO on the -PAPER FEED STROBE input line. This LO is applied to enabled NOR gate E167-13, where it combines with the LO from the -SELECT PRINTER input. The HI which results is applied to the clock input of D type FF Ap. FF Ap is set, and assumes the $Q=HI/\bar{Q}=LO$ status. FF Ap- $\bar{Q}=LO$ not only force sets J-K type FF Bp, whose \bar{Q} output goes to AND gate D140-8, but it is also applied to NAND gate J82-6, and as a strobe to the data input registers. Gate D140-8 goes LO, causing the output of gate N167-5 (-PAPER FEED READY) to go HI informing the controller that the printer is busy executing a paper feed command. FF Bp- $\bar{Q}=LO$ is also applied to FF Ap-D. FF Ap will reset on the trailing edge (negative going) of the -PAPER FEED STROBE input, and the FF Ap-D=LO status will keep it in this status, with its \bar{Q} output HI. If the -PW INTERLOCK input is HI (hammer fire portion of a print wheel movement is not in process), then the HI's from FF's Ap- \bar{Q} and Bp- \bar{Q} will enable NAND gate J82-6, whose output will go LO. R-S latch J70 will set, due to a HI from FF Bp- \bar{Q} , and the J82-6 LO, and its outputs will be J70-3=HI/J70-11=LO. J70-11 is the -PAPER FEED INTERLOCK output, where a LO status will inhibit the print wheel section's hammer fire logic. J70-3=HI enables AND gate D45-6, with both inputs HI, and applies a HI to FF Cp-J.
- (5) With J=HI, and K=LO, FF Cp will set with the next CLOCK-2 pulse. With FF Cp set, its $Q=HI$ output enables FF Dp to also set with the succeeding CLOCK-2 pulse. FF Dp- $\bar{Q}=LO$ will then disable AND gate D45-6, so that FF Cp can reset later at the end of the paper feed movement. FF Cp- $\bar{Q}=LO$ is applied to the divide-by-ten Counter at J58-R9₁/R9₂, AND gate J20-12, and the paper feed settling one-shot L20-B.
- (6) With a LO on its R9₁ and R9₂ inputs, divide-by-ten Counter J58's operation is enabled, and the counter begins to divide its 2KHz input by 10.

Figure 5-12 shows the relationship between the counter's input enabling LO (upper trace), and its 200 Hz output of 1 msec pulses spaced 4 msec apart (lower trace). The oscilloscope was set at 5 ms/cm, and connected to the terminals of J58. The counter is wired to preset to the count of 9. When FF Cp sets, the first 2 KHz clock input brings the counter to its zero state, and provides the first 200 Hz clock pulse.

- (7) AND gate K58-8 is enabled by the positive going 200 Hz pulses.
- (8) The K58-8 output is fed back to the data input registers as an indication of paper feed movement, and decrements the register. When the register has been counted down to a zero state (all stages set at 1), its output goes HI. This enables NAND gate L117-8 and disables AND gate K58-8 to stop the paper feed motor, and disables AND gate K58-12 to enable FF Cp reset on the next CLOCK-2 pulse, resetting FF Dp on the succeeding CLOCK-2 pulse.
- (9) Resetting of FF Cp sets the paper feed settling one-shot L20. When L20 resets approximately 45 msec later, it enables AND gate J20-12. J20-12=HI enables FF Bp to reset with the next CLOCK-1 pulse. Resetting of FF Bp resets latch J70, to remove the -PAPER FEED INTERLOCK=LO, and to remove the PAPER FEED READY=LO.

The data input sub-circuit is described in Figure 5-10B, and its components may be located by referring to Figure 5-11B. Its purpose is to:

- (1) Receive paper feed direction and distance information from the controller on its eleven data input lines;
- (2) Load the input data into its paper feed control register upon receipt of a strobe pulse from the paper feed control logic

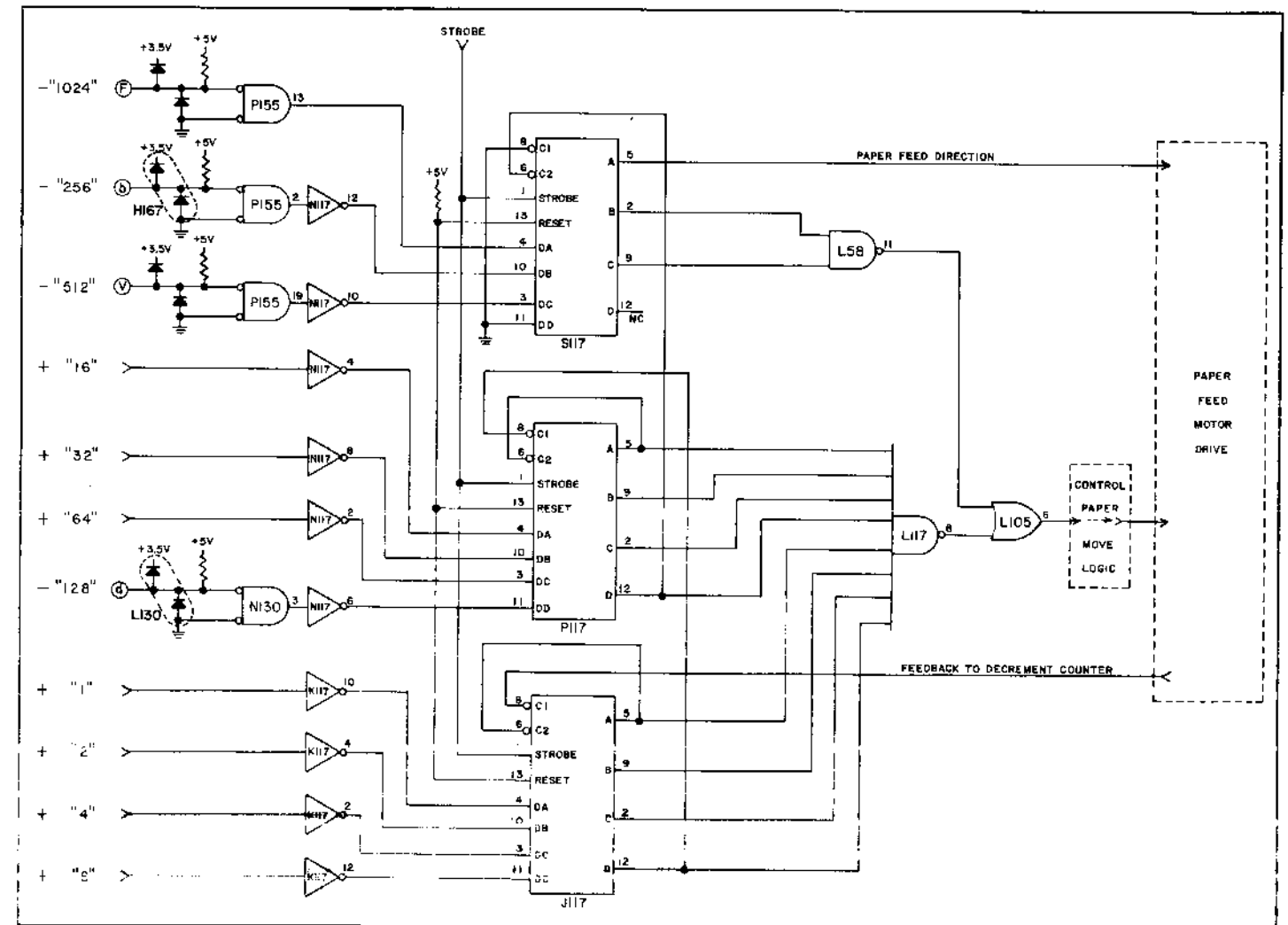

FIGURE 5-10B
CIRCUIT DIAGRAM — PAPER FEED DATA INPUT

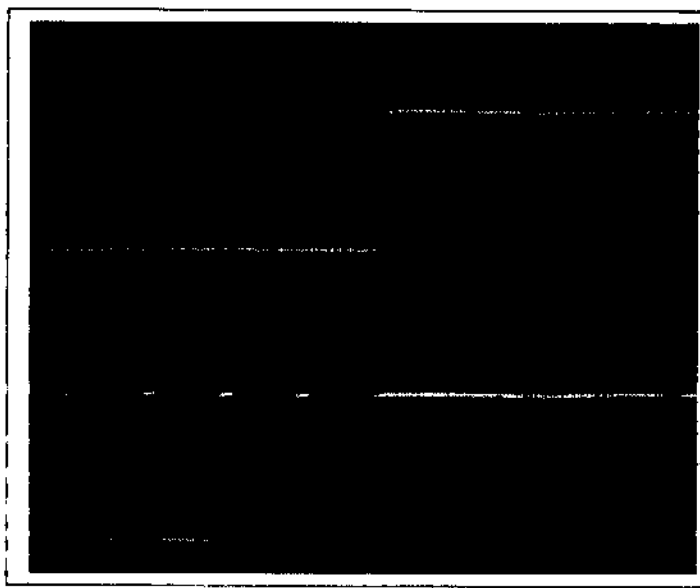

FIGURE 5-12
TIMING WAVEFORMS — PAPER FEED CIRCUIT

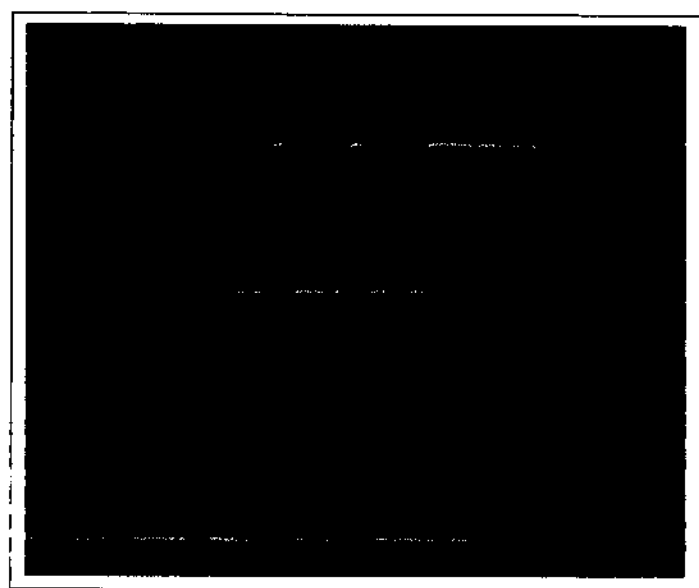

FIGURE 5-13
TIMING WAVEFORMS — PAPER FEED CIRCUIT

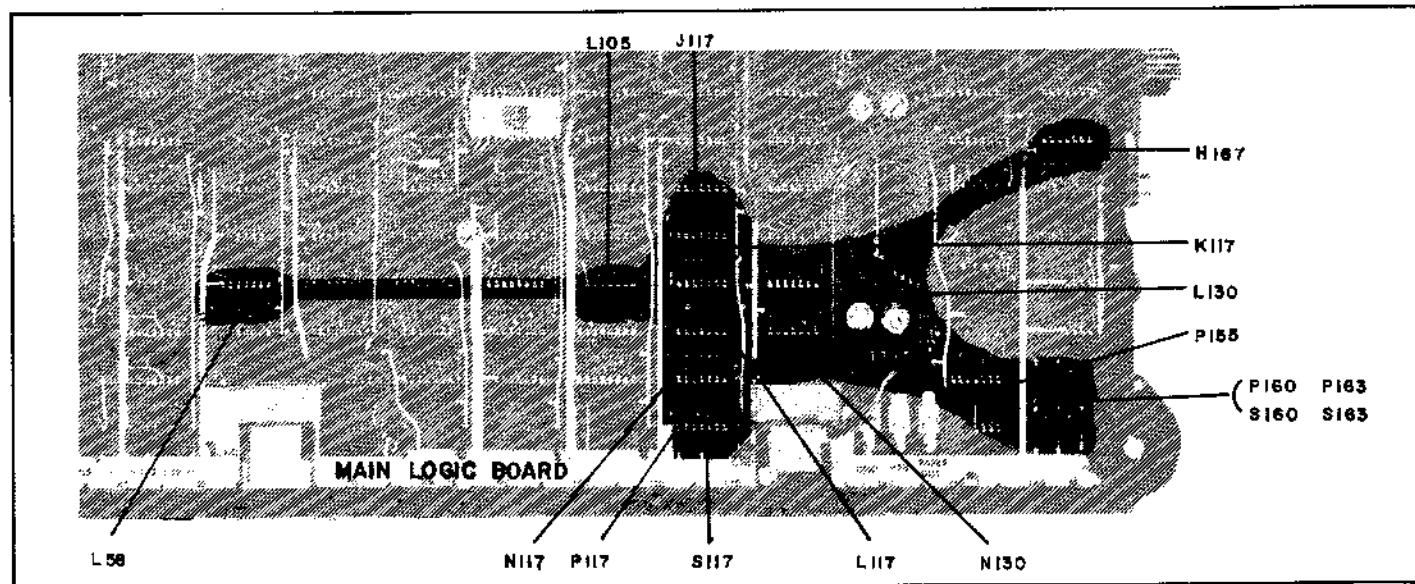

FIGURE 5-11B
COMPONENT LOCATIONS — DATA INPUT CIRCUIT

circuit;

- (3) Supply a HI signal to the control logic circuit as long as its register content equals 1 or more (any stage = LO), and to change this signal to a LO whenever the register content equals (outputs all 1's) 0; through gate L105; and
- (4) To use a feed back pulse from the control logic circuit as its clock, to decrement its register content toward 0.

NOTE: Zero's out of the register are weighted values.

Operation of the data input circuit is as follows:

- (1) Three 4-bit binary counter/storage elements, J117, P117, and S117 are interconnected to form a single 12-bit up-count register operated in a 1's complement binary system.
- (2) The register is connected to eleven data input lines, representing binary 1 through 1024. All lines have a noise suppression/voltage regulating circuit (input clamp) with a NOR gate, and all have an inverting amplifier/buffer except the high order (1024) bit line. The low order (1 through 512) bit lines carry paper feed distance data, in terms of 1/48 of an inch increment of movement per data bit, while the high order (1024) bit is the direction of paper feed movement control where LO = up and HI = down movement.
- (3) The controller places the data on the input lines at least 200 nsec before it issues the -PAPER FEED STROBE signal. Passing through the paper feed control logic, the 1 usec strobe LO, enables the register input gates, and the data is "loaded" into the register. The 200 nsec delay allows the data bit voltage levels to stabilize, to ensure that only the desired "bits" enter the register.
- (4) At the end of the strobe time, the control logic enables the data output OR gate L105-6. The presence of data in the register (register content greater than 0) produces L105-6=HI, which is sent to the paper feed control logic circuit. This HI is maintained as long as the register content is greater than 0.
- (5) The control logic circuit responds to L105-6=HI, by issuing drive pulses to the paper feed motor drive circuit. These pulses, one per 1/48" increment, are also fed back to the data register, where they decrement the register content. Eventually, these pulses will have caused the register to count itself down to 0. Simultaneously, the high order (1024) bit's HI or LO status is sent directly to the paper feed motor drive circuit, and is not altered by the count-down process.
- (6) When the register content reaches 0, its L105-6 output goes LO. L105-6=LO disables AND gates K58-8 and K58-12, to stop the paper feed motor drive pulses, and initiate the resetting of the paper feed control logic.

The paper feed motor drive circuit is described in Figure 5-10C, and its components may be located by referring to Figure 5-11C. The purpose of this circuit is to:

- (1) Receive a HI going 1 msec duration x 4 msec period pulse train from the control logic circuit, and use this to generate a phased pair ($\emptyset A$ and $\emptyset B$) of output pulse trains;

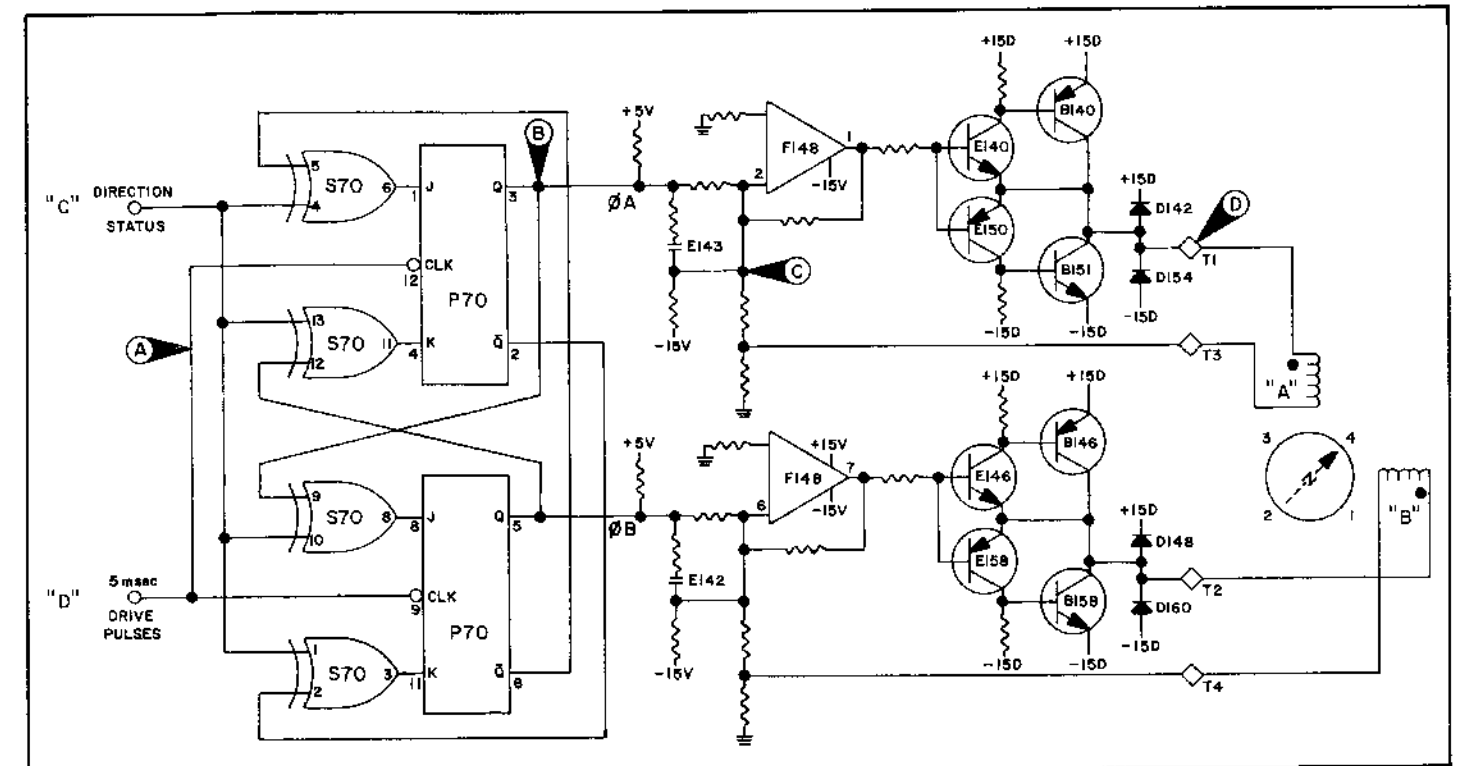

FIGURE 5-10C
CIRCUIT DIAGRAM — PAPER FEED MOTOR DRIVE

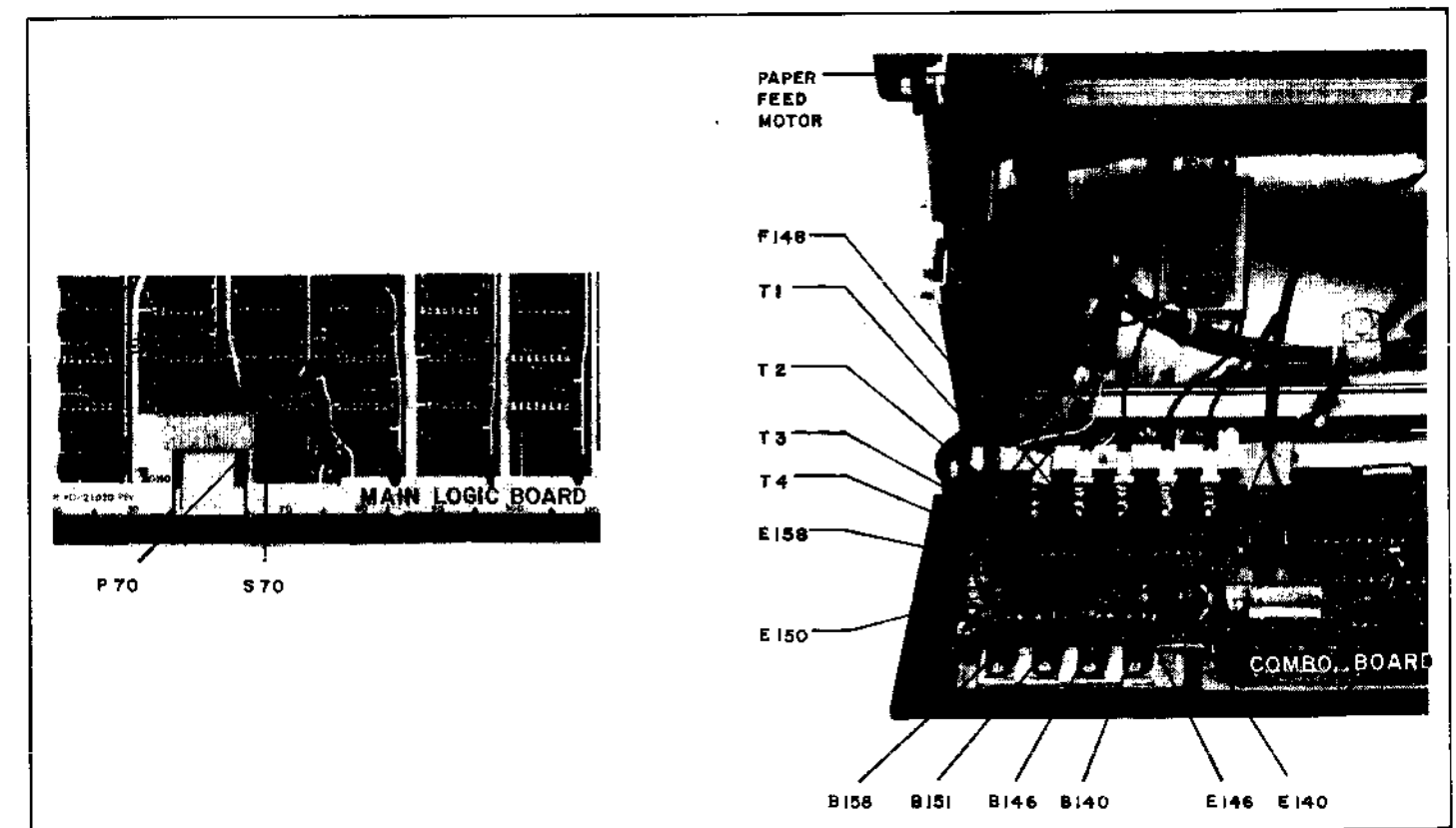

FIGURE 5-11C
COMPONENT LOCATIONS — PAPER FEED MOTOR AND DRIVE CIRCUIT

- (2) Receive a HI or LO signal from the data input register's high order (1024) data line, and use the status of this signal to control the phase relationship between the $\emptyset A$ and $\emptyset B$ output;
- (3) Use the $\emptyset A \emptyset B$ pulse trains to control the output of current amplifiers supplying drive power to the paper feed *stepper motor*. The motor will "step" (or move) one position of $7\frac{1}{2}^\circ$, equivalent to $1/48''$ of paper movement, for each change in *either* $\emptyset A$ or $\emptyset B$ polarity, with the direction of the "step" controlled by their phase relationship.
For UP movement, the phase sequence will be
 $\rightarrow -A \cdot -B \rightarrow A \cdot -B \rightarrow A \cdot B \rightarrow -A \cdot -B \rightarrow$ etc.
For DOWN movement, the phase sequence will be
 $\rightarrow -A \cdot -B \rightarrow A \cdot B \rightarrow A \cdot -B \rightarrow A \cdot B \rightarrow -A \cdot -B \rightarrow$ etc.; and
- (4) To feed back the incoming 5 msec pulse train to "clock" the data register, where each "step" of the motor is then matched by a corresponding decrease by one in the value held by the register.

The operation of the paper feed motor drive circuit is as follows:

- (1) The directional control signal, a HI or LO signal whose status remains unchanged during any one paper feed sequence, is applied to EXCLUSIVE-OR gates S70-1, 4, 10, and 13. The outputs of two cross-coupled J-K flip-flops are also applied to these same gates on S70-2, 5, 9, and 12.
- (2) The two J-K flip flops are then clocked by the 5 msec pulse train from the paper feed logic circuit.
- (3) The relative set or reset state of the flip-flops is not important at the start of any control sequence, and they can start in any one of the four possible combinations of state. As each sequence starts, the flip-flops begin to alternately change state with each 5 msec pulse. What is important is the direction in which the sequence progresses; that is, for any

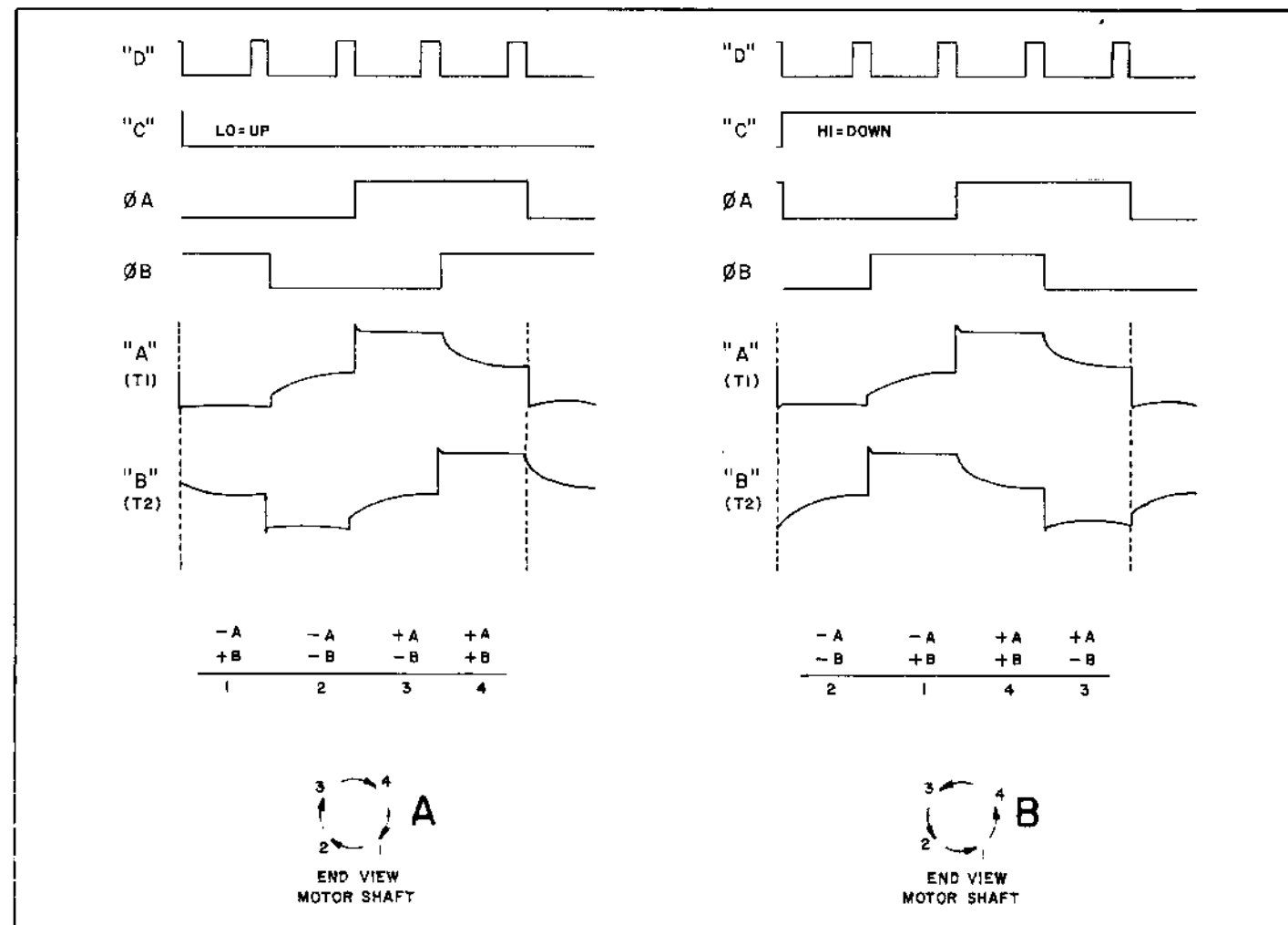

FIGURE 5-14
TIMING AND DRIVE WAVEFORMS — PAPER FEED DRIVE CIRCUIT (IDEAL)

given initial combination of states, what will be the next combination to be assumed by the flip-flops. This relationship, which determines the direction of paper feed, is controlled by the status of the directional control signal. Figure 5-14 illustrates this point.

- (4) The two flip-flops are cross-coupled, with the Q output of one tied to the J input of the other, and the \bar{Q} output tied to the K input of the other. Each interconnection is EXCLUSIVE-ORED with the directional control signal. The result is a selectable sequence of Q=HI outputs from the two flip-flops producing a pair of 90° phase related pulse outputs to the current drivers.
- (5) Assume that direction status = LO. P70-3=LO, and P70-5=HI. Then S70-6=LO, and S70-11=HI, and flip-flop P70-3/2 is balanced (input equals output). Flip-flop P70-5/6 is not balanced (S70-8=LO, and S70-3=HI), and will change state with the next clock pulse. S70-5 will then go HI, changing S70-11 to LO, and P70-3/2 will change state with the next clock pulse. This sequence, illustrated in Figure 5-14A, will continue as long as the 5 msec pulse train continues. Figure 5-14B illustrates the sequence for directional status = HI, where the stepper motor revolves in the opposite direction.
- (6) Figure 5-15 shows a group of related waveforms for the $\emptyset A$ channel as described in earlier paragraphs. These waveforms were taken with the oscilloscope connected to the points indicated.

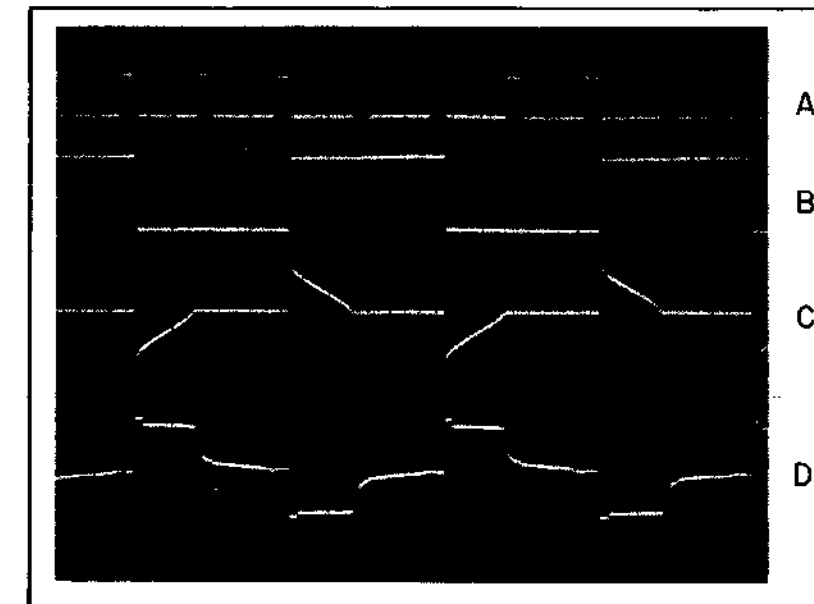

FIGURE 5-15
TIMING WAVEFORMS — PAPER FEED DRIVE CIRCUIT (ACTUAL)

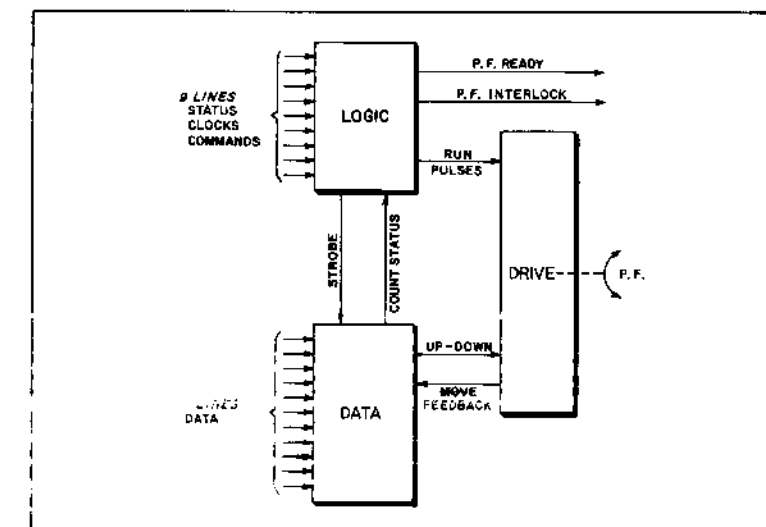

FIGURE 5-16
BLOCK DIAGRAM — PAPER FEED CIRCUIT

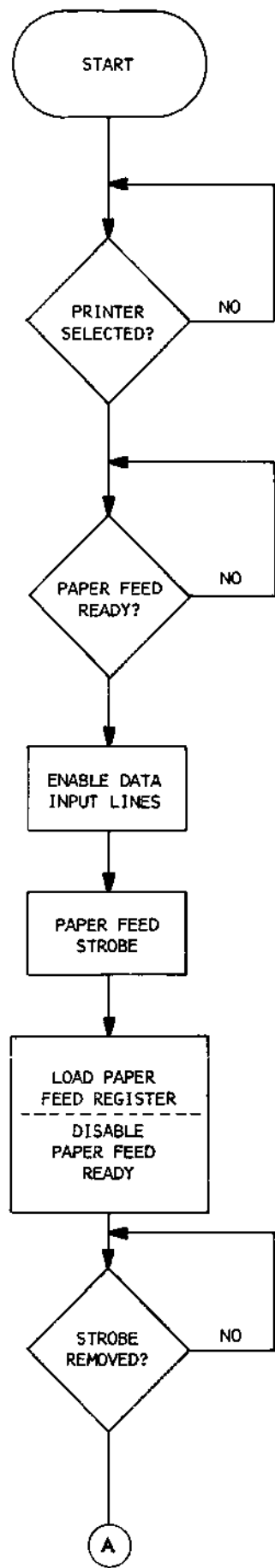
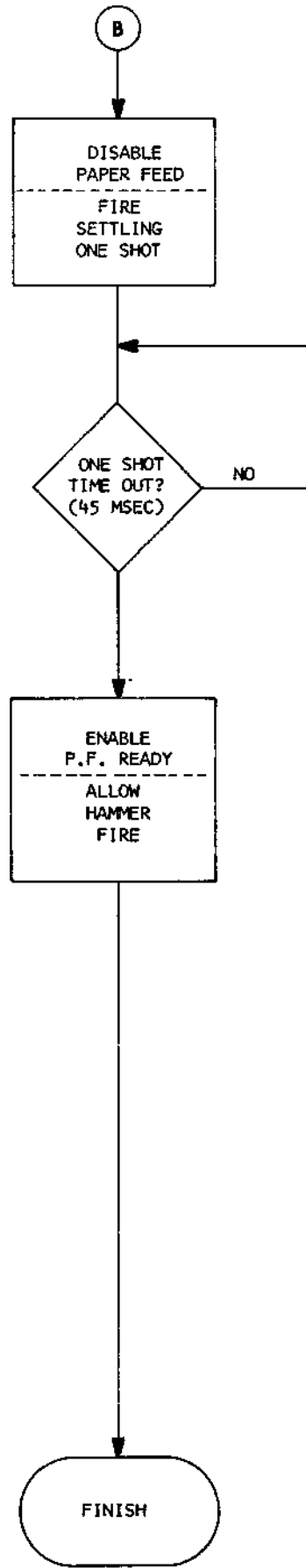
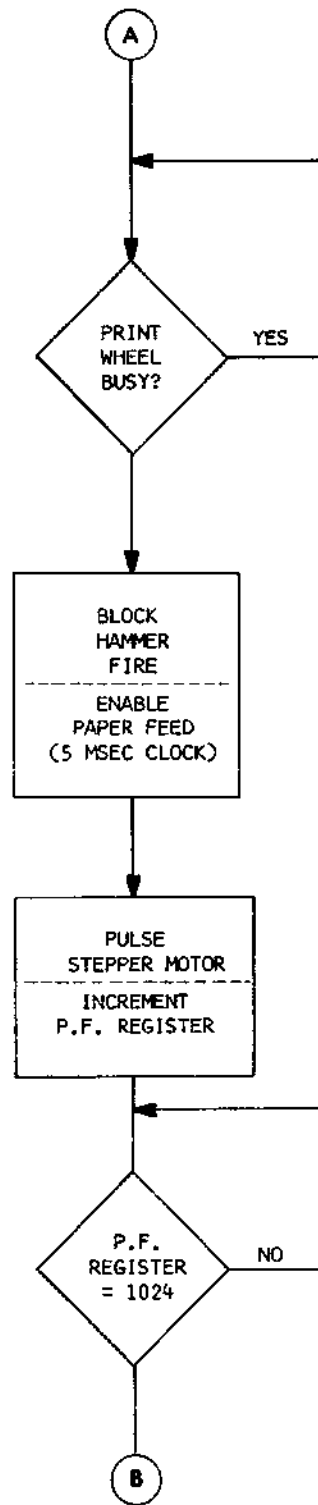

FIGURE 5-17
PAPER FEED FLOW CHART



- (7) The block diagram in Figure 5-16 illustrates the interrelation of the three parts of the paper feed circuit. Figure 5-17 is a flow chart further illustrating the sequence of events occurring in normal operation of the paper feed movement.
- (8) Figure 5-18 contains the many waveforms found throughout the paper feed circuit, and shows how they relate to each other.

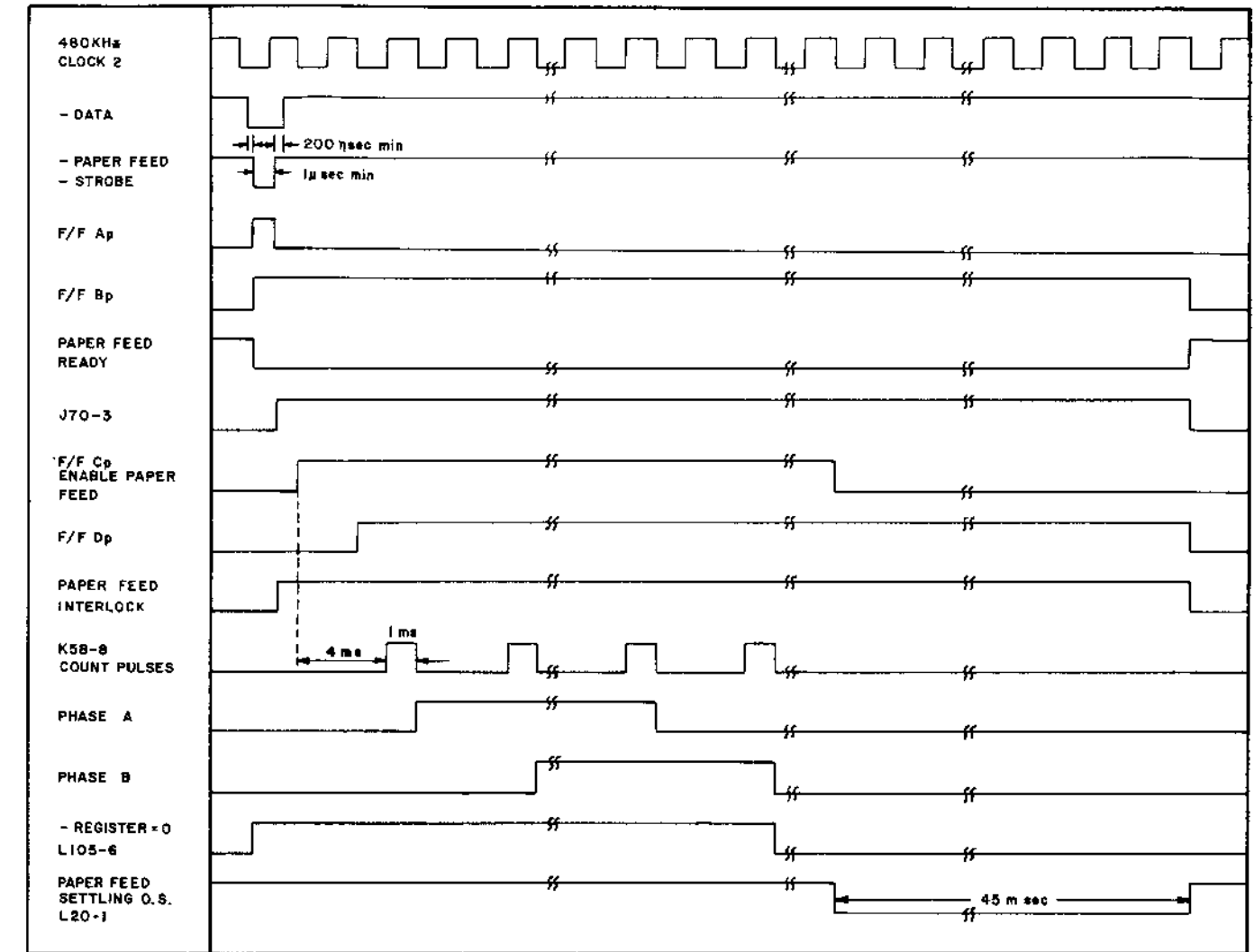

FIGURE 5-18
PAPER FEED TIMING WAVEFORMS

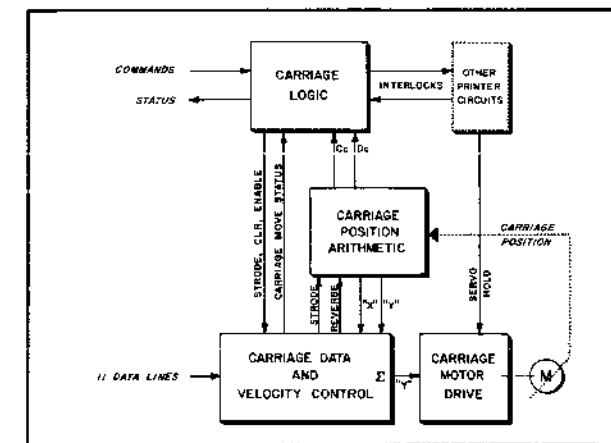

FIGURE 5-19
SIMPLIFIED BLOCK DIAGRAM — CARRIAGE MOVEMENT FUNCTION

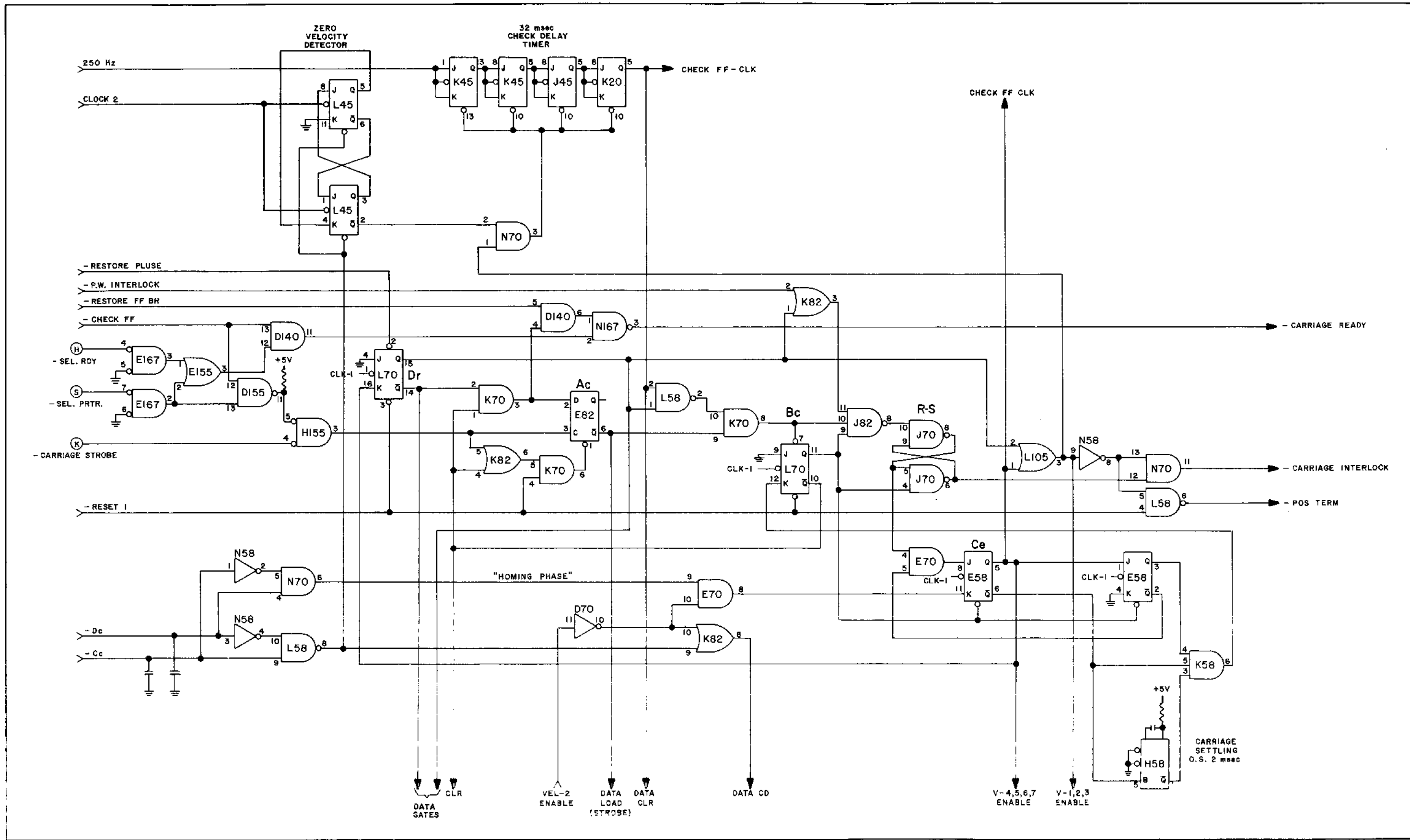

FIGURE 5-20A
CIRCUIT DIAGRAM — CARRIAGE CONTROL LOGIC

5.7 CARRIAGE MOVEMENT FUNCTION AND SEQUENCE

5.7.1 Function

The function of the Carriage Movement circuit is to control the movement or positioning of the carriage to the desired print column. Carriage movement is controlled in both distance and direction, as specified by the controller. Figure 5-19 is a simplified block diagram of the carriage movement circuit.

The circuit diagrams in Figures 5-20A-D describe the four parts of the carriage movement circuit, and Figure 5-21A-D show the location of the components for each section.

5.7.2 Sequence

The Carriage Movement circuit can be separated into four parts; Control Logic, Data Input/Velocity Control, Carriage Position Arithmetic, and Carriage Motor Drive.

The Carriage Control Logic is described in Figure 5-20A, and its components may be located by referring to Figure 5-21A. Its purpose is to:

- (1) Receive a Select Ready or Select Printer signal from the controller, and respond with a CARRIAGE READY signal if the carriage movement circuit is in fact ready to receive and process commands;
- (2) Receive a carriage movement command (which consists of data and execute signals), and initiate movement;
- (3) Issue a signal to the controller signifying carriage movement in process and/or movement completed;
- (4) Enable the generation of carriage motor velocity signals in the data section;
- (5) Issue count-down pulses to the data input register, based on receipt of signals from the position arithmetic section showing carriage movement;
- (6) Monitor carriage movement signals to detect absence of motion, and to initiate a check sequence should carriage movement be too slow, or stop prematurely;
- (7) Produce an interlock signal to inhibit hammer fire action in the print wheel section while the carriage is in motion;
- (8) Inhibit its own carriage movement during the hammer fire portion of a previously initiated print wheel movement sequence;
- (9) Disable its own operation upon receipt of a CHECK signal, reset its logic, and enable carriage movement upon receipt of a RESTORE signal; and

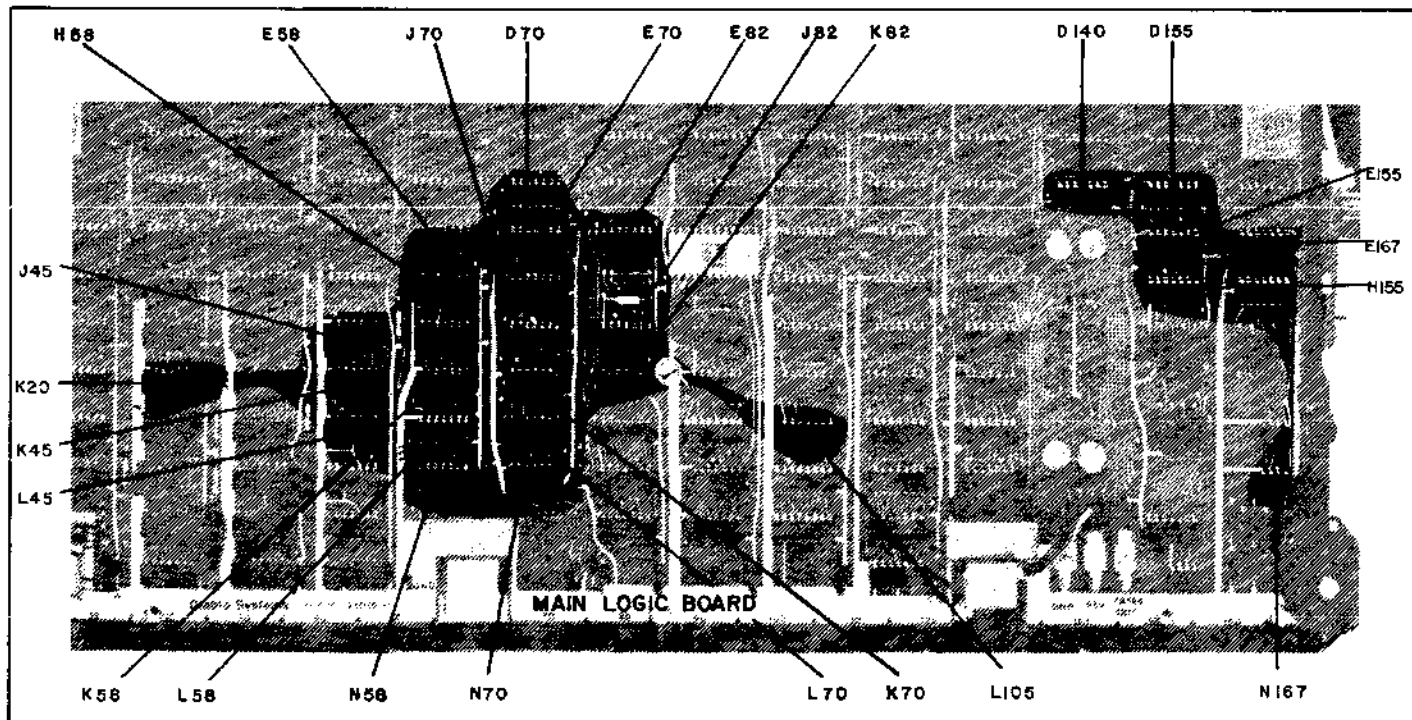

FIGURE 5-21A
COMPONENT LOCATIONS — CARRIAGE CONTROL LOGIC CIRCUIT

- (10) To issue a CARRIAGE READY signal when carriage movement has been completed.

Operation of the Carriage Movement Control Logic circuit is as follows:

- (1) Beginning in the quiescent state, all flip-flops are in the *reset* condition ($Q=LO/\bar{Q}=HI$), and all inputs except clocks are HI. The $-CARRIAGE\ READY$ and $-CARRIAGE\ INTERLOCK$ lines are also HI.
- (2) A $-SELECT\ READY=LO$ pulse applied to NOR gate E167-3 has the same result as in the Paper Feed circuit.
- (3) The $-SELECT\ PRINTER$ signal input, when LO, enables the printer's circuits to respond to commands from the controller. From NOR gate E167-2, the now $+SELECT\ PRINTER$ signal is applied to OR gate E155-3, where it follows the same sequence as the $-SELECT\ READY$ signal to produce the $-CARRIAGE\ READY=LO$ signal, and to NAND gate D155-11 for comparison with the $-CHECK\ FF$ status. If both are HI (printer is not in CHECK condition), a LO is passed to NOR gate H155-3. H155-3 is enabled, and the carriage logic is ready to receive commands.
- (4) The controller, having received the $-CARRIAGE\ READY=LO$ signal, first places carriage movement data on the data input lines and then, after a minimum 200 usec delay, places a LO signal on the $-CARRIAGE\ STROBE$ input line. This LO is applied to enabled NOR gate H155-3. The resultant $H155-3=HI$ is applied to the clock input of D type FF Ac. FF Ac is *set*, and its Q output goes LO. $Ac-Q=LO$ enables the inputs of the carriage data register to load the direction and distance data into the register, and force sets FF Bc through OR gate K70-8. At the end of the $-CARRIAGE\ STROBE$ signal, the LO on $Ac-C$ resets FF Ac. Then, $Ac-\bar{Q}=HI$ through K70-8 combines with $Bc-Q=HI$, and with OR gate K82-3=HI through NAND gate J82-8 to *set* R/S flip-flop J70-8/6. The output at OR gate K82-3 will be HI except during the hammer fire portion of the print wheel sequence, when the resulting LO from OR gate K82-3 will disable NAND gate J82-8 and R/S flip-flop J70-8/6. A restore sequence will also disable R/S flip-flop J70-8/6. *Setting* of R/S flip-flop J70-8/6 produces $J70-6=LO$ which, applied to AND gate N70-11, causes this output to go LO. This is the $-CARRIAGE\ INTERLOCK$ line. J70-8, now, HI, is applied to AND gate E70-6 which, with a HI from FF Dc-Q, places a HI on FF Cc-J. If the carriage data register content is not 0, $FF\ Cc-K=LO$, and FF Cc will *set* with the trailing edge of the next CLOCK-1 pulse.
- (5) *Setting* of FF Cc produces $Cc-Q=HI$, which enables carriage velocity gates 4,5,6, and 7 directly, enables carriage velocity gates 1,2, and 3 through OR gate L105-3, and places a HI on FF Dc-J. FF Dc will *set* with the next CLOCK-1 pulse. *Setting* of FF Dc prepares FF Cc to reset when the carriage data register has been counted down to 0 where $FF\ Cc-K=HI$. $FF\ Dc-Q=HI$ also partially enables AND gate K58-6. OR gate L105-3=HI also enables AND gate N70-3, which allows zero velocity detector flip-flop L45-2Q=HI to *reset* the 32 msec CHECK DELAY TIMER (K45-3/5, J45-5, and K20-5), which then begins to run.
- (6) While the carriage is in motion, a pair of phased pulse trains, $-Cc$ and $-Dc$, are generated in the carriage position arithmetic section. Through inverter N58-4 and NAND gate L58-8, these two inputs produce a negative going pulse train where each pulse equals 1 increment (1/60th of an inch) of carriage movement. Each pulse then *resets* the Check Delay Timer and, through OR gate K84-8, which is enabled through inverter D70-10=LO by a value of 1 or more in the carriage data register, decrements the register content by 1. Through inverter N58-2 and AND gate N70-6, and through AND gate E70-8 which is enabled by inverter D70-10=LO, the $-Cc/-Dc$ phased pulse trains place a LO on FF Cc-K. The negative pulse train from AND gate N70-6 is called the "homing phase" signal where, again, each pulse equals 1/60th of an inch, or 1 increment, of carriage movement. Each increment represents a possible carriage stopping point, or detent, and while a new "homing phase" signal is generated for each increment, the signal is used only when the carriage has reached its destination print column. When this happens, the register output equals 0, and AND gate E70-8 is disabled, placing a HI on FF Cc-K. FF Cc will *reset* with the next CLOCK-1 pulse.
- (7) FF Cc, in its reset state ($Q=LO/\bar{Q}=HI$), produces a signal called $-POS\ TERM$ through OR gate L105-3, inverter N58-8, and NAND gate L58-6. This signal is sent to the carriage motor drive circuit to be used in detenting (electrically "locking") the carriage drive motor in position.
- (8) FF Cc, in its reset status, also enables a 2 msec delay one-shot H58-1. This delays FF Bc reset for 2 msec, to allow time for the carriage motor detenting to stabilize. At the end of the 2 msec delay, FF Bc *resets*. FF Bc then resets the rest of the logic to its not busy state, and produces $-CARRIAGE\ READY=HI$ and $-CARRIAGE\ INTERLOCK=HI$.
- (9) During a restore sequence, the *setting* of FF Dr produces OR gate L105-3=HI, to enable velocity gates 1,2, and 3. FF Dr in *setting*, also produces outputs ($Q=HI/\bar{Q}=LO$), and enters a value of 12 as a part of the restore sequence.

The Carriage Data Input/Velocity Control circuit is described in Figure 5-20B. Its components are found on two circuit boards, and may be located by referring to Figures 5-21B and 5-21C. Its purpose is to:

- (1) Receive carriage movement distance and direction data from controller on its eleven data input lines;

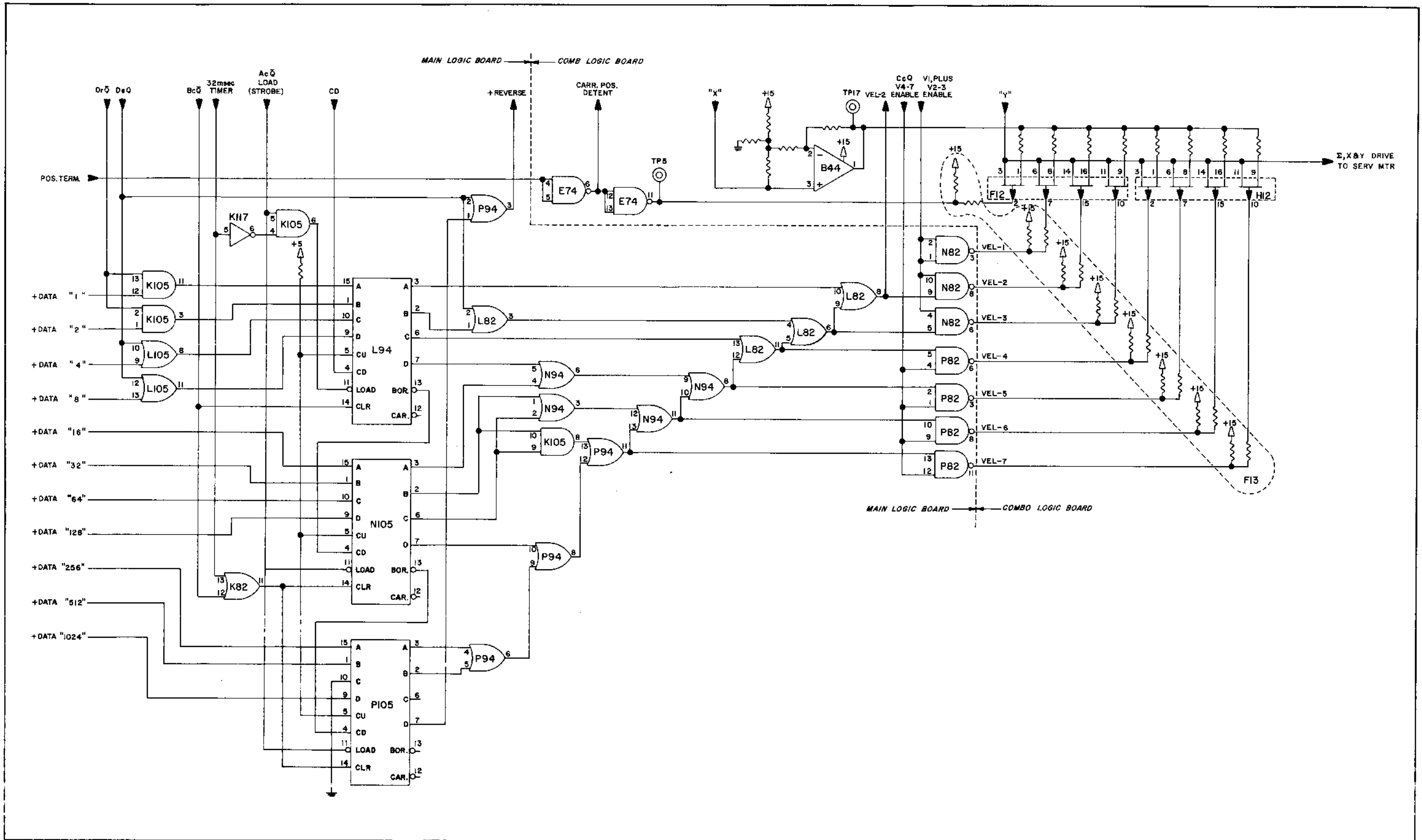

FIGURE 5-20B
 CIRCUI T DIAGRAM — CARRIAGE DATA INPUT/VELOCITY CONTROL

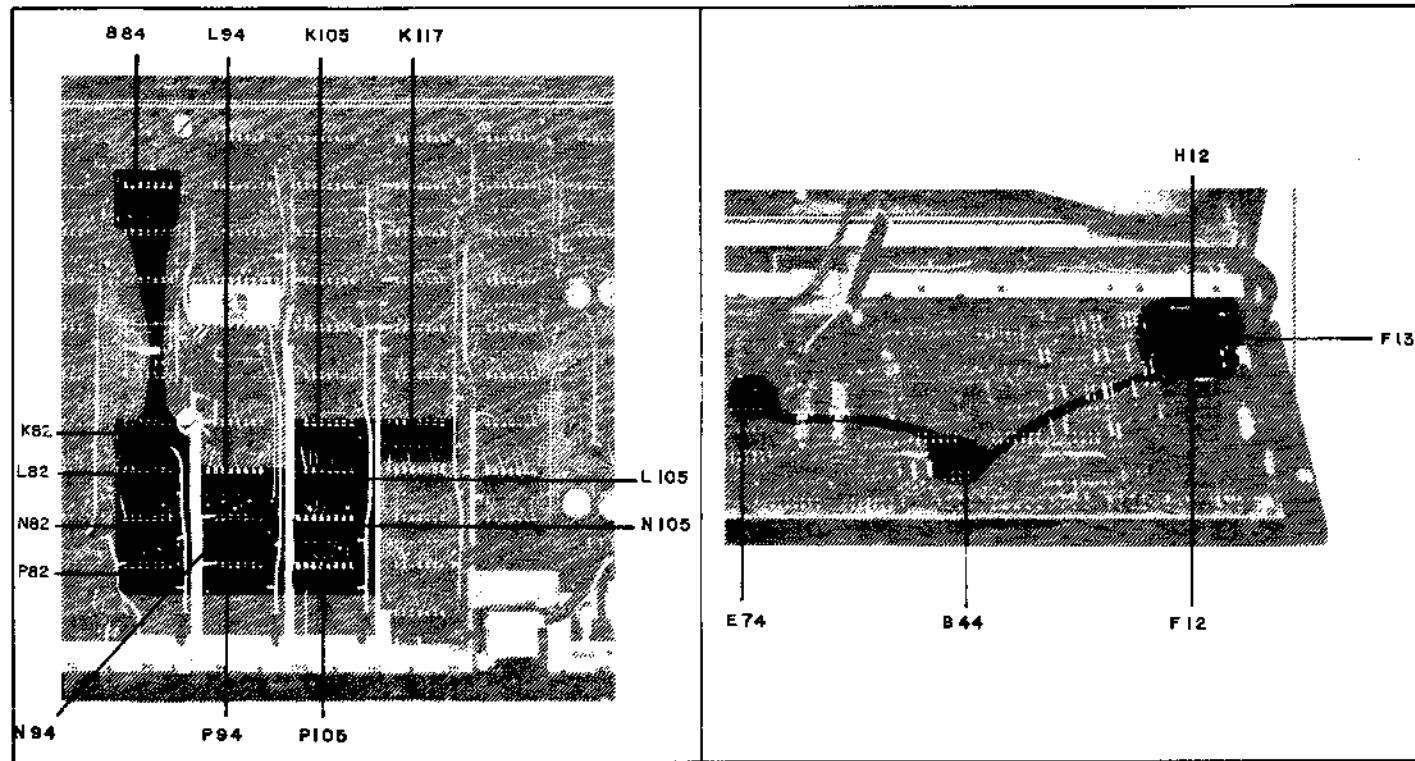

FIGURE 5-21B COMPONENT LOCATIONS — CARRIAGE DATA INPUT/VELOCITY CONTROL CIRCUIT

- (2) Receive a strobe (load) signal from the control logic circuit, and use this signal to gate the input data into the data register;
- (3) Receive velocity enable signals from the control logic circuit, and to use these in combination with the contents of the data register to gate the "X Velocity Command Reference" voltage from the carriage arithmetic circuit into the velocity summation network;
- (4) Receive the "Y Velocity Feedback" voltage from the carriage arithmetic circuit, and to sum this with the gated "X Velocity Command Reference" voltage to produce the carriage motor drive voltage;
- (5) Receive and process the -POS TERM signal from the control logic circuit, and to not only use this signal in the summation network to generate carriage motor detent, or holding, voltage following a completed move, but to also supply this signal to the carriage arithmetic circuit where it aids in the generation of the "X" and "Y" voltage components of the carriage motor detent process;
- (6) Sense the value of the eleventh, or highest order (1024) data line, and generate appropriate signals for the carriage arithmetic circuit to control the direction of carriage movement;
- (7) Receive a series of count-down pulses from the control logic circuit, one for each increment of carriage movement, and use these to decrement the contents of the data register; and
- (8) Receive three signals from the control logic circuit to be used to clear the register at the end of a movement sequence, and to hold the rest of the data register clear while entering a value of 12 during the second half of a restore sequence.

Operation of the carriage data input/velocity control circuit is as follows:

- (1) The controller places the eleven bit carriage positioning instruction on the data input lines. These are all pulses of at least 1.4 usec duration. The polarity of the data bit on the highest order (11th or binary 1024) data line determines the direction the carriage is to move, where a LO=movement to the right, and a HI=movement to the left. The low order data lines are normally all HI. Those lines used to express the binary equivalent of the distance to be traveled by the carriage are changed to LO status at the interface.
- (2) The controller then issues a -CARRIAGE STROBE signal to the control logic circuit. As outlined above, the control logic circuit sets up, and produces those signals of immediate interest to the carriage data/velocity control circuit. One of these, the data load command pulse from FF Ac-Q=LO, strobes the data registers L94-11, N105-11 and P105-11. Note that the load pulse for register L94-11 is gated through AND gate K105-6. This gate is used

during a restore sequence, and will be discussed later in this section. The second and third signals are HI's used to enable velocity NAND gates N82-3/N82-8/N82-6 for velocity gates 1,2, and 3, and NAND gates P82-6/P82-3/P82-8/P82-11 for velocity gates 4,5,6, and 7 respectively.

- (3) The register load inputs L94-11/N105-11/P105-11=LO causes their OA/OB/OC/OD outputs to assume the status of their A/B/C/D inputs. Assume a starting situation where all register outputs are LO, and disregard P105-7 for the moment. This will apply LO's to all the inputs of OR gates L82-3, L82-8, L82-6, L82-11, N94-6, N94-8, N94-3, N94-11, P94-11, P94-8, P94-6, and to AND gate K105-8, and result in a LO being applied to the velocity NAND gates. As stated above, these gates are enabled by HI's from the control logic circuit shortly after the data load strobe was received. Note that VEL-1 NAND gate N82-3 is fully gated by the enabling signal. As the registers are loaded, a pattern of HI's will appear on the register output lines. The OR gates following are so arranged that the highest order data bit will cause its own and ALL lower order bit velocity NAND gates to gate on, and apply a LO to their respective FET's in the summation network. Thus, while VEL-1 FET is turned on (F12-7=LO) with the enable HI's, the turning on of VEL-2 through VEL-7 FET's is dependent on the content of the data register. Table 5-1 below illustrates this relationship.

REGISTER VALUE	VELOCITY GATES TURNED ON
0 (VEL enabled)	N82-3 VEL-1
1 or More	N82-3/8 VEL-1 & 2
2 or More	N82-3/8/6 VEL-1, 2, & 3
4 or More	P82-6, N82-3/8/6 VEL-1, 2, 3, & 4
8 or More	P82-3/6, N82-3/8/6 VEL-1, 2, 3, 4, & 5
32 or More	P82-3/6/8, N82-3/8/6 VEL-1, 2, 3, 4, 5, & 6
96 or More	P82-3/6/8/11, N82-3/8/6 VEL-1 through 7

- (4) AND gate K105-8 provides the switching capability to turn on gate P82-11 (VEL-7) for a 96 count (64 and 32), and yet not turn it on for a 64 or a 32 count.
- (5) OR gate L82-3 provides the switching capability to turn on gate N82-6 (VEL-3), along with gate N82-8 (VEL-2) during a restore sequence when control logic restore FF Dr-Q=HI.
- (6) Gate N82-3 (VEL-1) is turned on anytime the control logic circuit enables the velocity gates, and represents the minimum velocity for any carriage move.
- (7) The status of the high order data input, from register P105-7, is applied to OR gate P94-3, along with control logic FF Dr-Q status. A LO input from both register and FF Dr-Q, indicating carriage movement right, produces a +REVERSE=LO signal to the carriage arithmetic circuit. A HI status from either or both sources produces a +REVERSE=HI status, and results in carriage movement to the left.
- (8) A signal is generated in the carriage arithmetic circuit called "X VELOCITY COMMAND REFERENCE." This signal is a reference voltage level which is developed in the carriage arithmetic circuit, and represents carriage movement. "X" is amplified in B44, and applied to source connections of the summation network FET's F12/H12, through a series of parallel resistors whose values get progressively smaller for each higher order velocity gate. A second signal from the same source called "Y FEEDBACK REFERENCE," is applied to the drain connection of these same FET's, as a common connection. This line is also the output to the carriage motor drive circuit.
- (9) Those summation FET's whose control gates are LO (respective velocity gate turned on), will turn on. This gates "X" voltage on to the "Y" line through the parallel resistors, with the algebraic sum being proportional to the distance to be traveled by the carriage.
- (10) Carriage movement then results in carriage data register decrementation. As the register value falls below certain levels, as specified in Table 5-1, the higher order velocity gates are disabled, fewer and fewer summation FET's are left on, resulting in a drive signal which rises to some level, and then diminishes toward zero in steps as the distance left to travel decreases. Figure 5-22 illustrates this point.
- (11) When the carriage has reached the commanded position (register decremented to 0), and has stopped a -POS TERM=LO is produced in the control logic circuit. This signal is applied to buffer NAND gate E74-6. E74-6=HI is passed to the carriage arithmetic circuit for generation of appropriate 'X' and 'Y' voltages, and to NAND gate E74-11. E74-11=LO turns on one summation FET. The resultant drive signal "locks" the carriage drive motor in a detent condition.

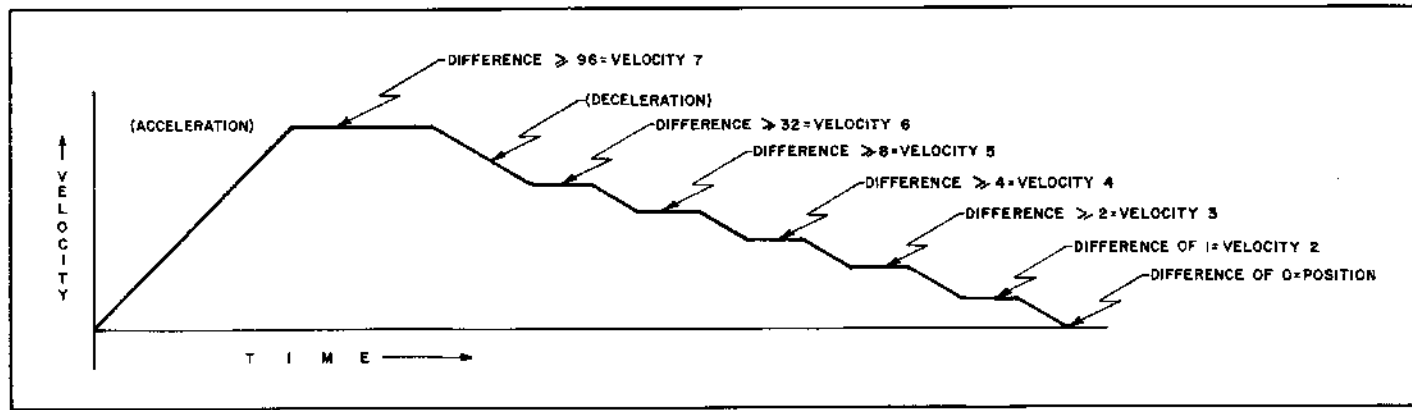

FIGURE 5-22
CARRIAGE SERVO SPEED SELECTION

(12) During a restore sequence, the carriage is driven against the left mechanical stop, and then positioned two column spaces (12 increments) to the right. At the start of the sequence, control logic restore FF Dr sets. The resultant Dr-Q=HI: (Refer to Figure 5-20A and Figure 5-20B).

- Enables Velocity Gate-1 through Control Logic OR gate L1053;
- Enables Velocity gates 3 and 2 through OR gate L82-3;
- Enables a +REVERSE=HI signal to the carriage arithmetic circuit; and
- Places a HI on the 4 and 8 inputs to register L94 through OR gate L105-8/11.

The carriage moves left at velocity 3, and comes to rest against the left mechanical stop. 32 msec after the carriage comes to rest, the Control Logic's CHECK DELAY TIMER times out. The resultant HI is applied through inverter K117-6 and OR gate K105-6 to load the data value of 12 into the register, and through OR gate K82-11 to clear the 8 higher order registers. +REVERSE goes LO, and the carriage moves 12 increments (register value 12) to the right. This completes the carriage movement portion of a RESTORE sequence, and the circuits return to a detent situation.

The Carriage Arithmetic (Servo) circuit is described in Figure 5-20C, and its major components may be located by referring to Figure 5-21D. Its purpose is to:

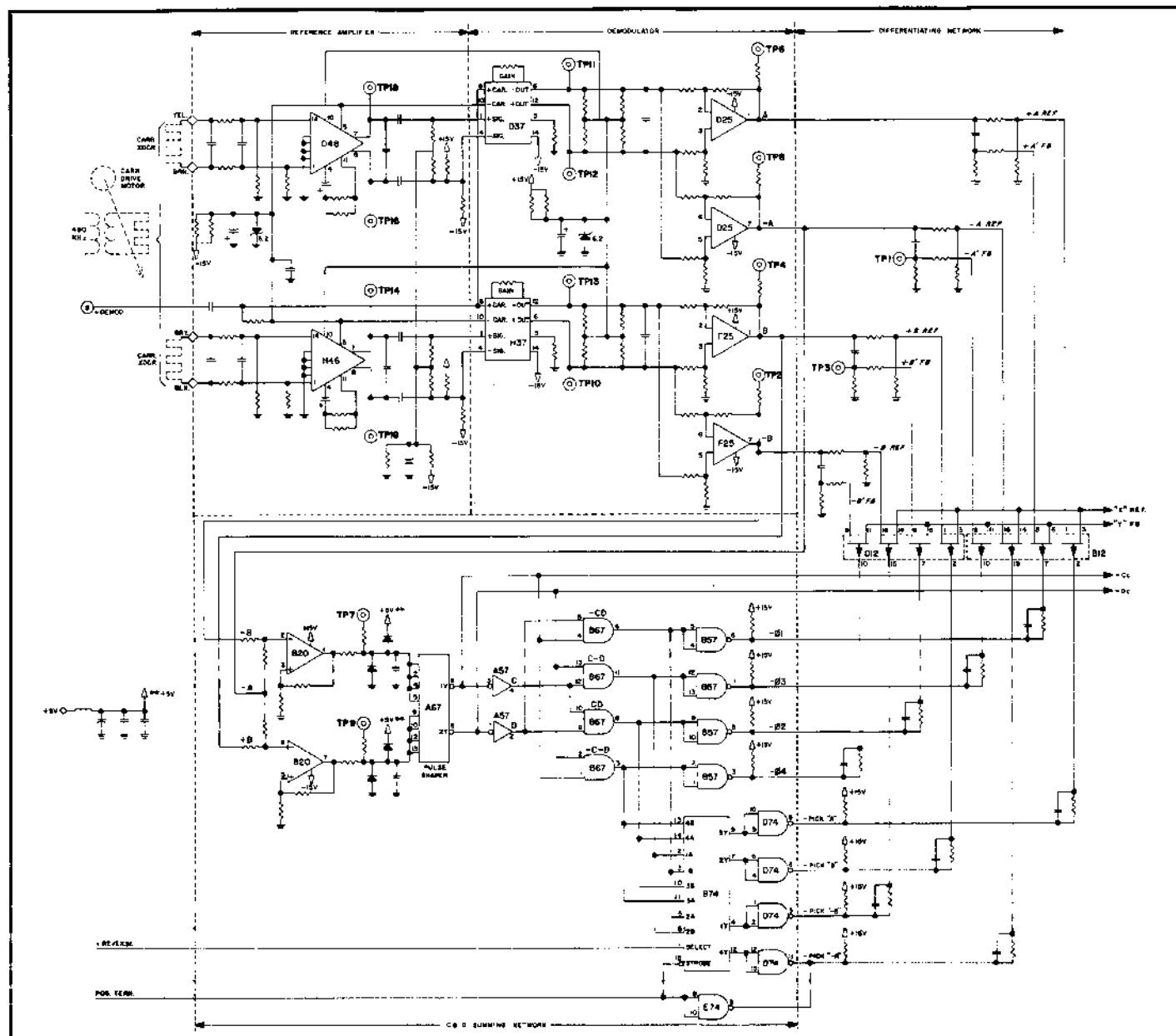

FIGURE 5-20C
CIRCUIT DIAGRAM — CARRIAGE ARITHMETIC

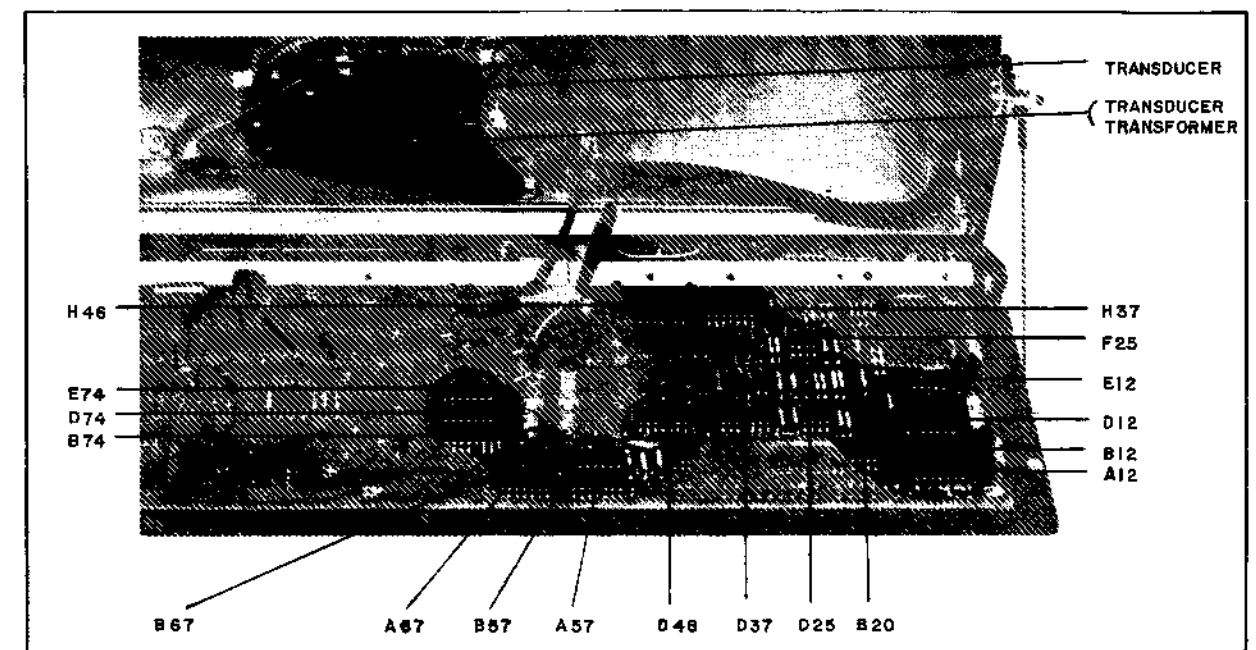

FIGURE 5-21D
COMPONENT LOCATIONS — CARRIAGE ARITHMETIC CIRCUIT

- Generate two 480 KHz modulated ac signals ($\emptyset A$ and $\emptyset B$), phase shifted 90° from each other, through a rotary transducer mounted on the carriage motor;
- Use these two $\emptyset A$ and $\emptyset B$ signals, plus a +REVERSE signal from the carriage data input circuit, to produce the following:
 - Cc and -Dc pulse trains, to decrement the carriage data register, and to initiate a logic reset at the end of a carriage movement.
 - "X Velocity Command Reference" and "Y Velocity Feedback" waveforms for use in the carriage data/velocity control circuit to provide carriage motor drive voltage; and
- Forms of the "X" and "Y" voltages needed to electrically "lock" the carriage motor in a detent position.

Operation of the carriage arithmetic circuit is as follows:

- Whenever the power is applied to the printer, a 480 KHz carrier signal is generated, and applied to the primary of an air core transformer, which is mounted on a plate located over the free end of the carriage servo motor shaft. The secondary of this transformer is mounted on the rotary member of a shaft position transducer, which is fastened to the free end of the carriage servo motor shaft. The stationary member of the transducer is mounted on the end of the motor housing. See Figure 5-20D.

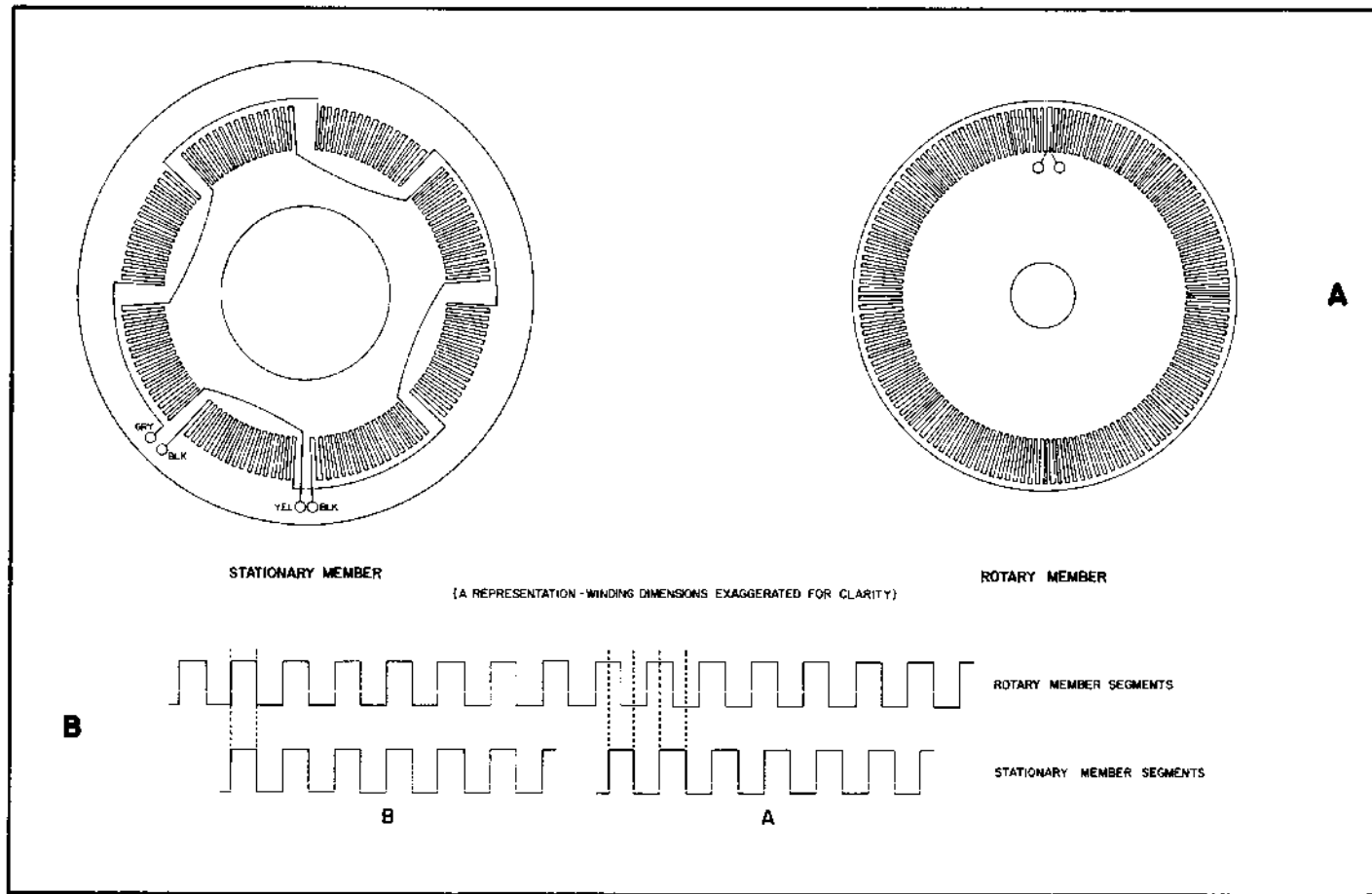

FIGURE 5-23
CARRIAGE MOTOR DRIVE POSITION TRANSDUCER

As shown in Figure 5-23, the "winding" of the rotary transducer member is symmetrical, while the "winding" of the stationary member is not. The stationary "winding" is divided into eight segments, which are alternately connected together into two groups of four segments each. The four segments of one group are displaced laterally a distance

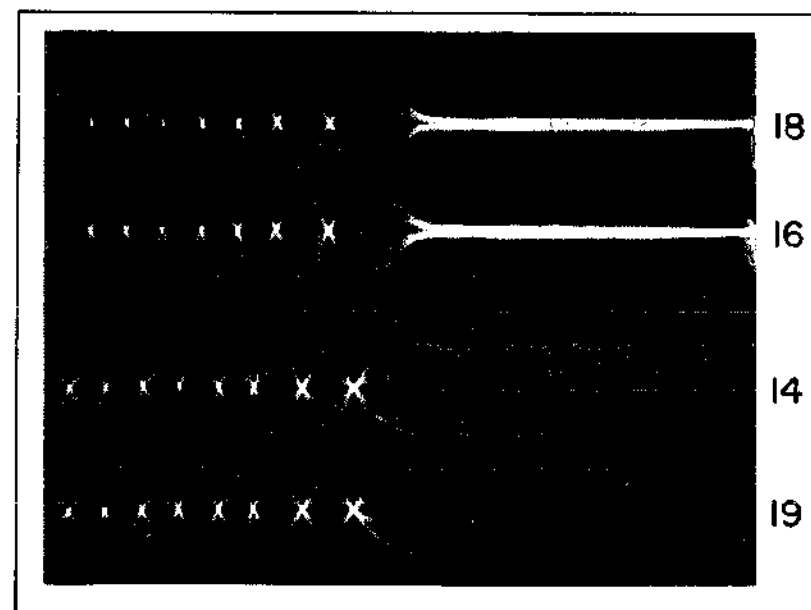

FIGURE 5-24
CARRIAGE ARITHMETIC WAVEFORMS

equal to one half winding width, which is equivalent to 90° of electrical phase difference. The output of the groups are labeled $\emptyset A$ and $\emptyset B$.

Each winding group is coupled to the inputs of a differential amplifier, D48 for $\emptyset A$, and H46 for $\emptyset B$. These amplifiers each have a normal and an inverted output. Figure 5-24 shows the waveforms present at the outputs of these two amplifiers, at test points TP18, 16, 14, and 19, with the motor first in motion and then coming to a stop. These waveforms illustrate the phase relationship between the top $\emptyset A$ signals and the bottom $\emptyset B$ signals. The right half of these waveforms shows the static conditions present after the motor has stopped. The system is arranged so that when the motor is in a normal stop (or detent) position, $\emptyset B$ transducer coupling will be maximum, and $\emptyset A$ coupling will be minimum. As the motor starts to rotate, the 480 KHz $\emptyset A$ and $\emptyset B$ signals will vary in amplitude, due to the changing relationship between rotor and stator transducer "windings," and the frequency of this amplitude variation (or modulation) will depend on the velocity of the motor.

- The outputs of D48 and H46 (connections 7 and 8) pass through DC offset networks to a pair of demodulator modules D37 and H37. Demodulation removes the 480 KHz component from the input signals, leaving the low frequency AM component. Amplifier modules D25 and F25 amplify and invert the four demodulated and phase related signals, designated +A, -A, +B, and -B.

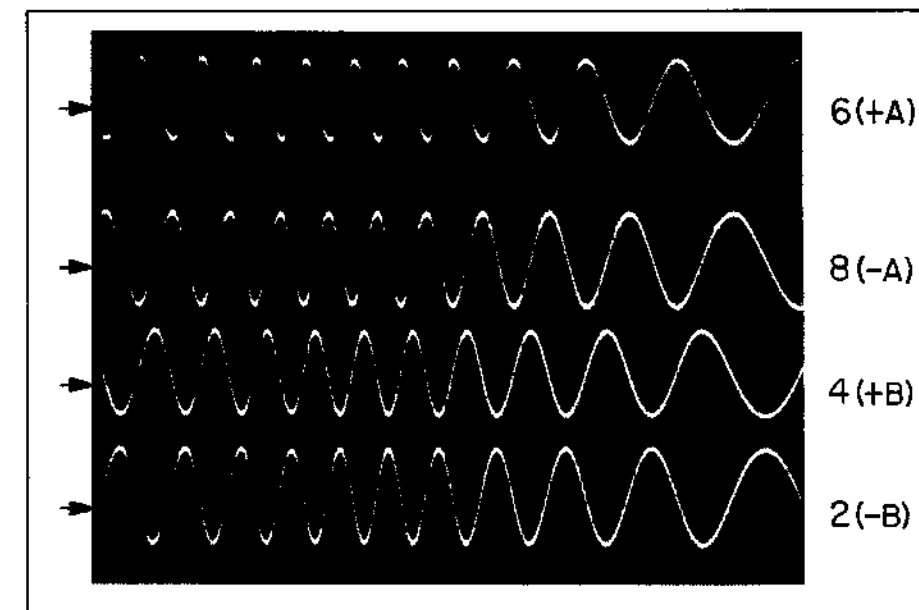

FIGURE 5-25
CARRIAGE ARITHMETIC WAVEFORMS

Figure 5-25 shows these four waveforms, taken at their associated test points of TP6 (+A), TP8 (-A), TP4 (+B), and TP2 (-B). These four waveforms are applied to the source connections of four FET's, as a part of the Reference FET network, to eventually become the "X Velocity Command Reference" signal.

The +A, -A, +B, and -B signals are also coupled, as +A', -A', +B', and -B', to the source connections of a second series of four FET's, as part of the Feedback FET network, to eventually become the "Y Feedback" signal. Coupling is by means of a high pass filter network, where the resultant signals applied to the FET's are based on the frequency (i.e., motor velocity) of the applied +/-A', or +/-B' signals. Figure 5-26 shows this relationship for the -A/-A' and +B/+B' signals. These waveforms were taken at (top to bottom) TP8, TP1, TP4, and TP3.

- Signals -A, +B, and -B are also applied to a circuit called the "C and D Summing Network", consisting of a pair of pulse shaper schmitt trigger connected operational amplifier (B20-1/7), and a pair of pulse shaper connected schmitt trigger modules (A67-6/8).

Figure 5-27 shows the waveforms at test points TP7 (top), and TP9 (bottom). The C Summing network generates a HI through A67-6, designated "-C", whenever the sum of the -A and -B inputs to schmitt trigger B20-1 is greater than 0 volts. The D Summing network generates a HI through A67-8, designated "-D", whenever the sum of the -A and +B inputs to schmitt trigger B20-7 is greater than 0 volts.

- The -C and -D signals are applied to the carriage control logic circuit, as "-Cc" and "-Dc", where they are used to generate the count-down pulses for decrementing the carriage data register. They are inverted, through A57-4/2, to produce +C and +D. Together, +/-C and +/-D are applied to an AND gate network to produce B67-6 = -C+D,

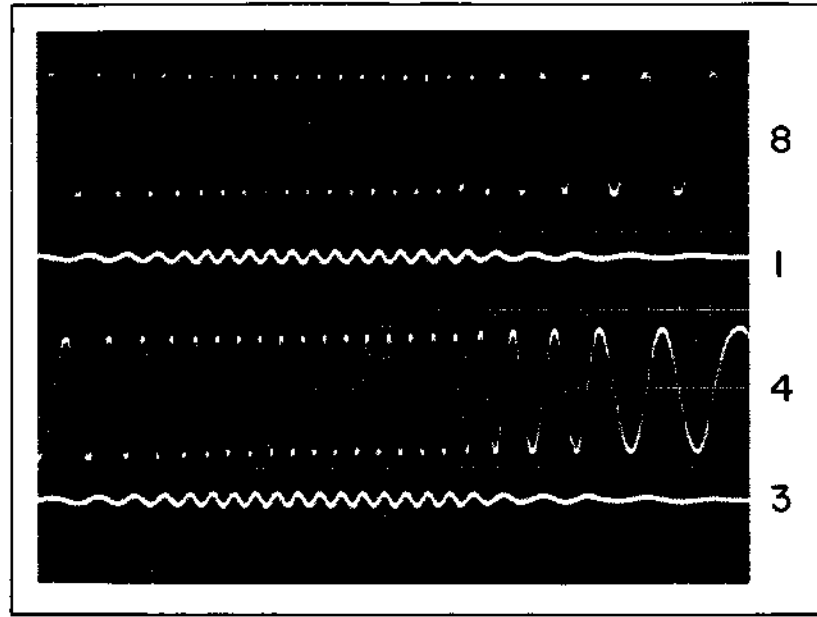

FIGURE 5-26
CARRIAGE ARITHMETIC WAVEFORMS

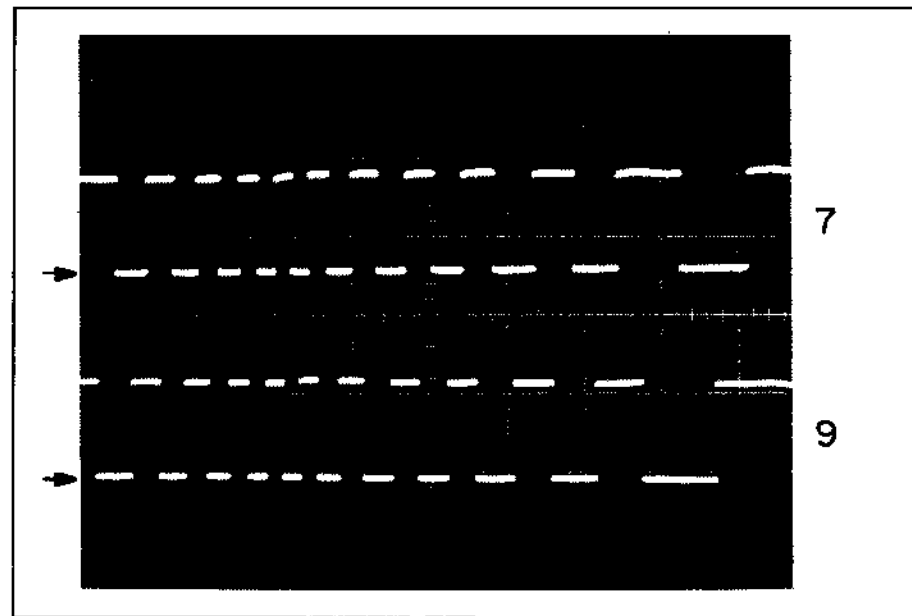

FIGURE 5-27
CARRIAGE ARITHMETIC WAVEFORMS

B67-11 = +C-D, B67-8 = +C+D, and B67-3 = -C-D. Beyond these gates, a series of NAND gates then produce B57-6 = -Phase +A', B57-11 = -Phase -A', B57-8 = -Phase +B', and B57-3 = -Phase -B'. These four "Phase" waveforms, shown in Figure 5-28, are applied to the gate connections of the Feedback FET's, to turn them on and multiplex the +/-A' and +/-B' waveform peaks on to the "Y" line. On the "Y" line, the resultant composite signal is used as feedback at the velocity summing point in the Carriage Data/Velocity Control circuit.

- (5) The B67 signals (-C+D/+C-D/+C+D/-C-D) are also applied to multiplexer B74. The multiplexer combines these four signals, under control of the +REVERSE signal from the Carriage Data/Velocity Control circuit, to generate the four signals -Pick+A, -Pick-A, -Pick+B, and -Pick-B. The "-Pick" signals are applied to the gate connections of the Reference FET's, to turn them on and multiplex the positive peaks (to move carriage right), or negative peaks (to move carriage left) of the +/-A and +/-B waveforms on to the "X" line. On the "X" line, the resultant positive or negative ripple reference level is applied to the velocity control network in the Carriage Data/Velocity Control circuit, where it becomes Velocity Command Reference Level.

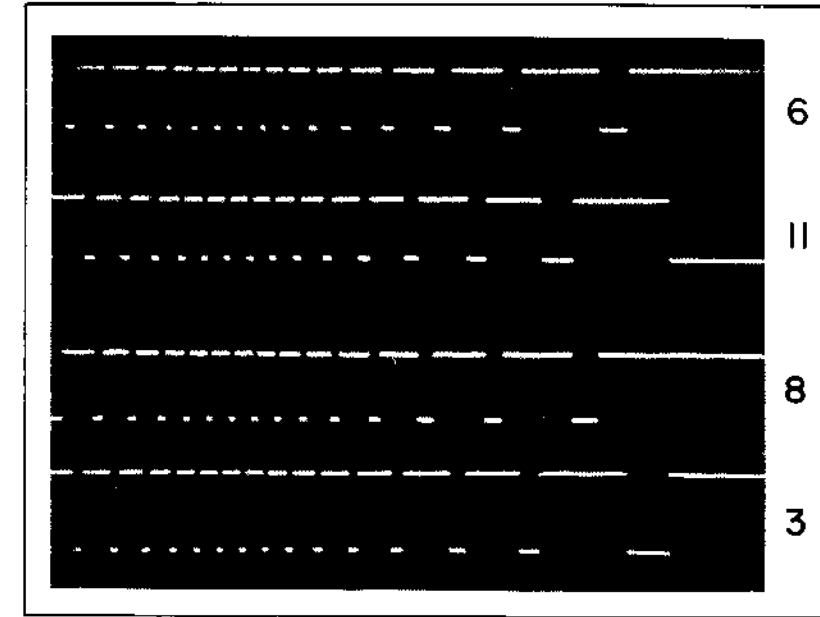

FIGURE 5-28
CARRIAGE ARITHMETIC WAVEFORMS

- (6) A status of carriage movement signal coming into the velocity control network, called -POS TERM, is NAND gated and applied to the strobe input of multiplexer B74-15 as a carriage motor detent (or servo hold) signal, and is also applied to NAND gate E74-8. When this signal goes HI, at the end of carriage movement, it disables the multiplexer, which turns off the Reference FET's, and through NAND gate E74-8 enables just the Reference FET for "-A." With no "Y" feedback voltage, due to the lack of carriage motor movement and the resultant +/-A' and +/-B' signals, the -A will feed through the motor drive circuit to electrically "lock" the motor in its detent position.
- (7) The Carriage Motor Drive Circuit is described in Figure 5-20D, and its components may be located by referring to Figure 5-21F. Its purpose is:
- (a) To receive the summed +/- "Y" drive signal from the velocity control network, and use this to control drive

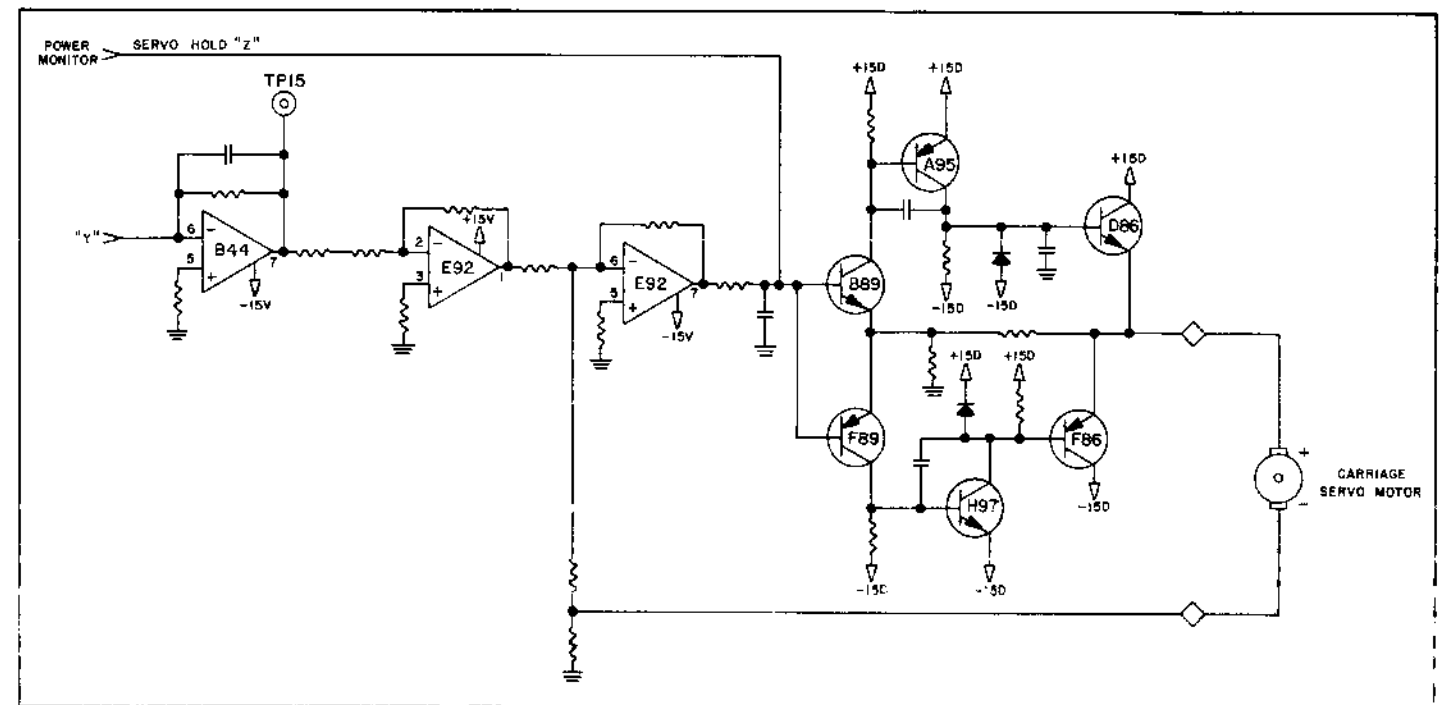

FIGURE 5-20D
CIRCUIT DIAGRAM — CARRIAGE MOTOR DRIVE

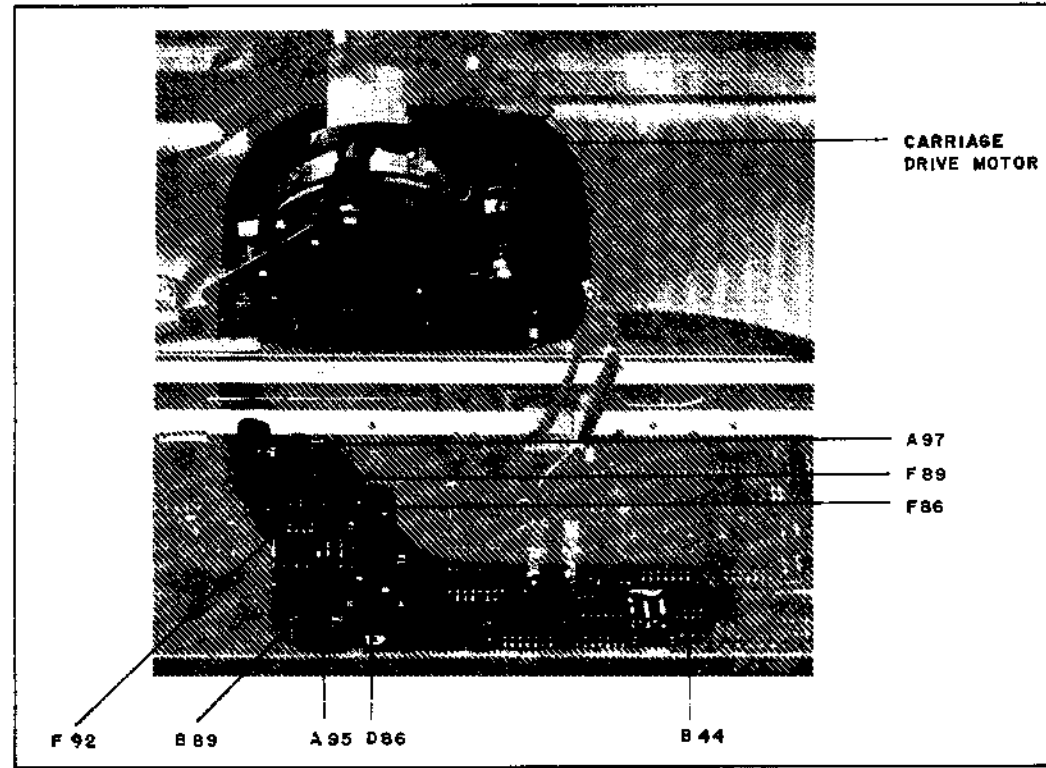

FIGURE 5-21E
COMPONENT LOCATIONS — CARRIAGE MOTOR DRIVE CIRCUIT

current to the carriage servo drive motor to drive the carriage in the proper direction at the correct velocity to the command position, and/or to hold it in a detent position; or

- (b) To receive a "Z" Servo Hold LO signal from the Power Monitor circuit to disable the motor drive during a CHECK condition, or initial power up or power down sequence.

Operation of the Carriage Motor Drive circuit is as follows:

- (1) The sum of "X REFERENCE" and "Y REFERENCE", the top waveform in Figure 5-29, is applied to amplifier

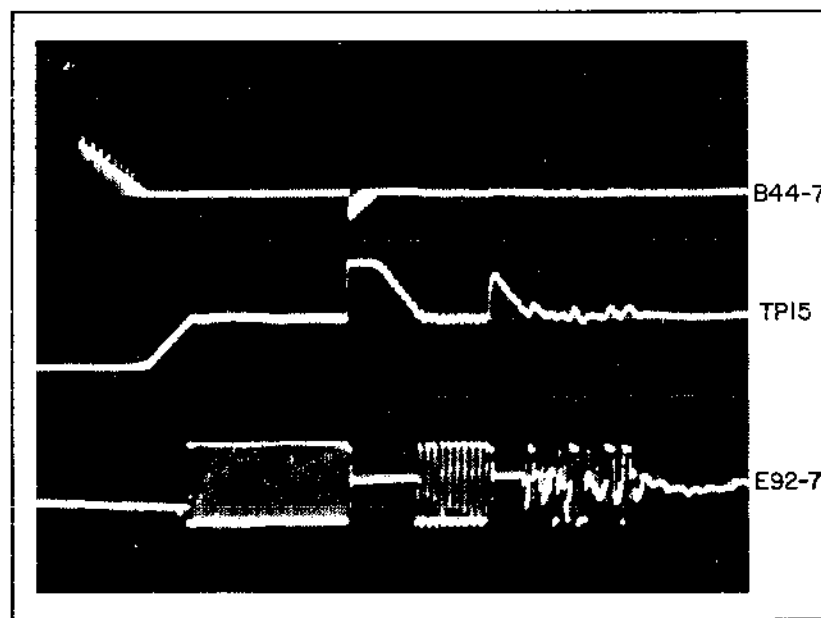

FIGURE 5-29
CARRIAGE MOTOR DRIVE WAVEFORMS

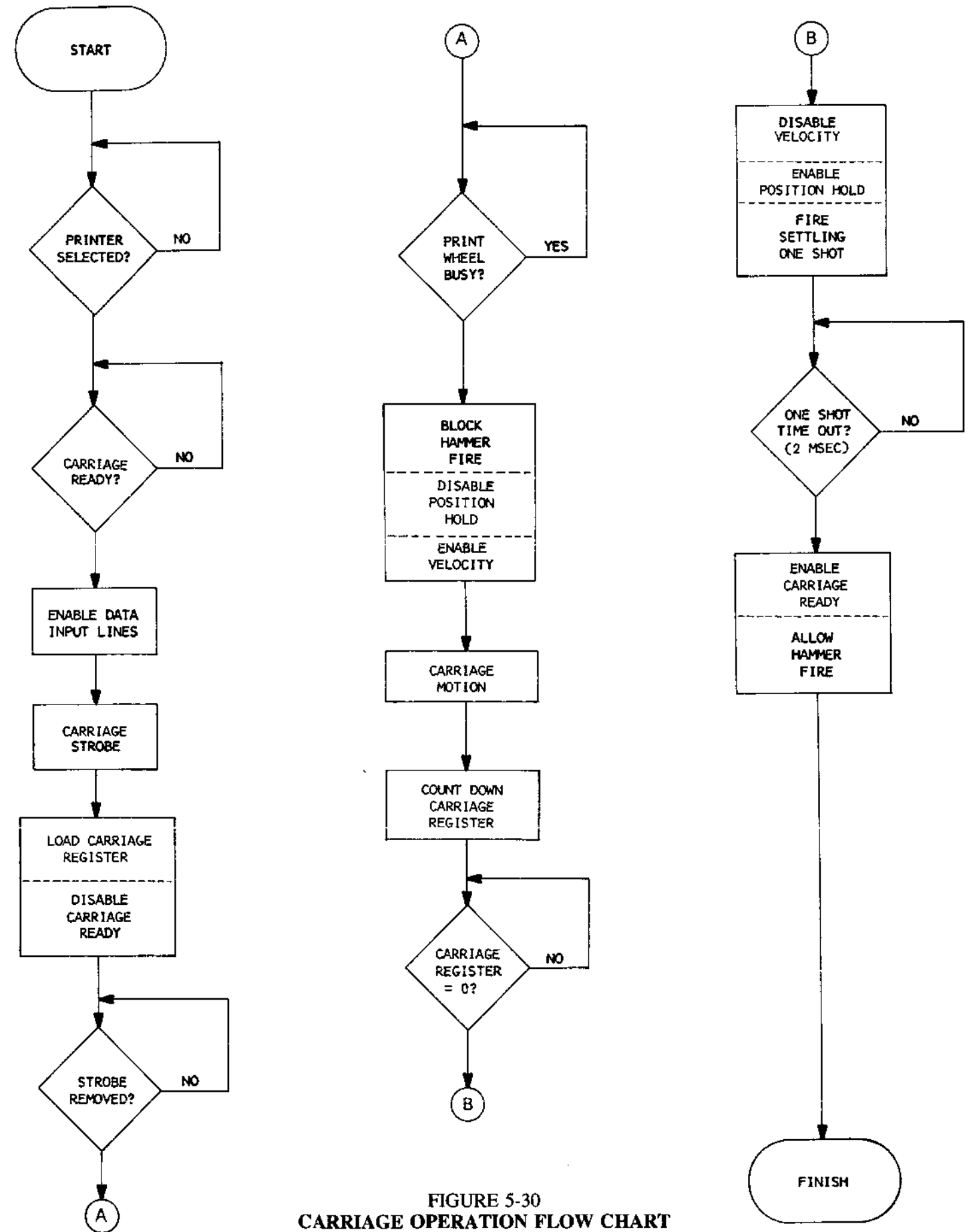

FIGURE 5-30
CARRIAGE OPERATION FLOW CHART

B44-6. The output of this amplifier, as seen at test point TP-15 (the center waveform in Figure 5-29), is applied to amplifiers E92-2 and E92-6. The output of these amplifiers, as seen at E92-7, the bottom waveform in Figure 5-29, is applied to the current amplifier circuit, on the bases of switching transistors B89 and F89. A positive going signal from E92-7 will be coupled through transistors B89 and A95 to turn on driver transistor F86. These two transistors control the speed and direction of carriage movement.

5.8 RIBBON LIFT/HOLD FUNCTION AND SEQUENCE

5.8.1 Function

The function of the Ribbon Lift circuit is to provide for control of the color of the print-out when using a two-color ribbon cartridge. Figures 5-31A and B describe the circuit, and the components may be located by referring to Figures 5-32A and B. The two-color ribbon cartridge is shown in Figure 1-2.

When required by the using system, the controller issues a command to a selected printer to raise the ribbon to the upper position. It should be noted that this is always the case when a standard ribbon is used. The narrow one-color ribbon is dropped clear of the print impact area when in the down position. The wider two-color ribbon prints on the red portion when it is in its down position.

5.8.2 Sequence

The Ribbon Lift circuit can be divided into two parts; the Control Logic circuit, and the Ribbon Lift/Hold Driver circuit.

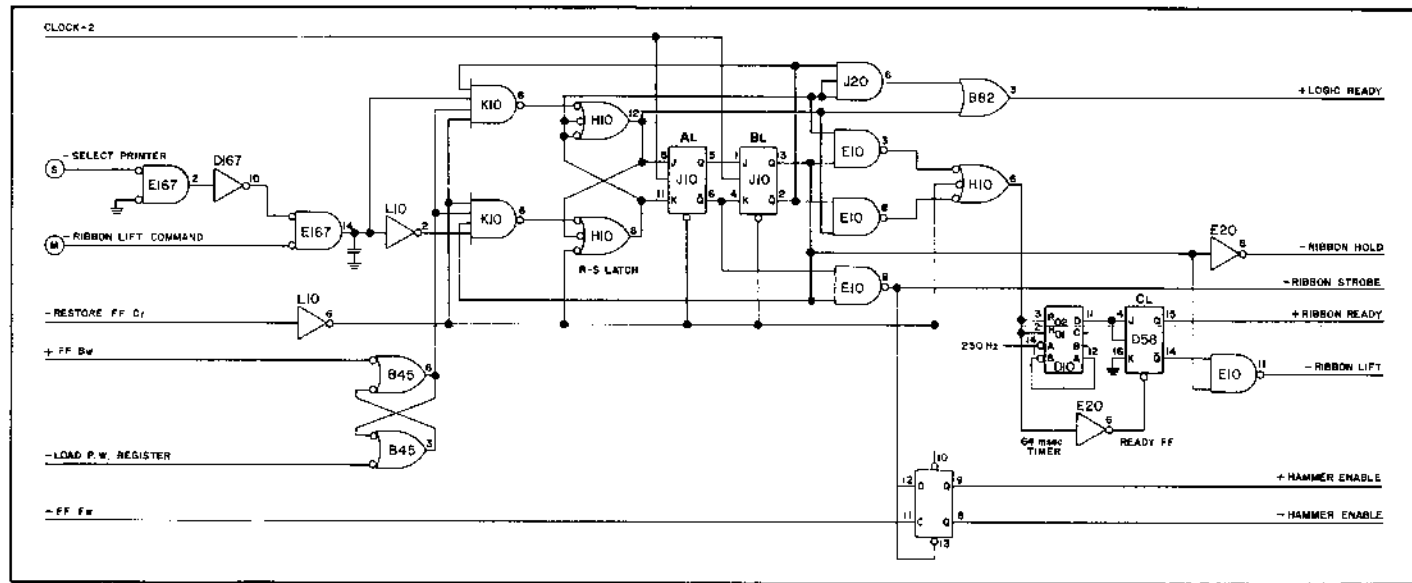

FIGURE 5-31A
CIRCUIT DIAGRAM — RIBBON LIFT CONTROL LOGIC

The Ribbon Lift Control Logic circuit is described in Figure 5-31A. Its components may be located by referring to Figure 5-32A. Its purpose is to:

- (1) Receive a $\text{-RIBBON LIFT COMMAND}$ signal from the controller, once the printer has been selected, and three status-of-printer signals from other circuits;
- (2) Use these signals to generate several output signals to drive the ribbon lift, to establish the status of the ribbon lift circuit, and to initiate actions in other circuits;
- (3) Disable Ribbon Lift, and reset its logic upon receipt of a signal from the Restore circuit; and
- (4) Allow an in-process print cycle to be completed before deactivating ribbon lift, should the $\text{-RIBBON LIFT COMMAND=LO}$ be removed during the print cycle.

The Ribbon Lift Control Logic circuit operates as follows:

- (1) A simultaneous condition of $\text{-SELECT PRINTER=LO}$ (Printer is selected), $\text{-RIBBON LIFT COMMAND=LO}$ (printer commanded to raise the ribbon), -RESTORE FF Cr=LO (printer not in a restore cycle), +FF Bw=LO / $\text{-LOAD PRINT WHEEL BUFFER=HI}$ (printer not in a print cycle), plus the *reset* state of FF BL ($\text{Q=LO}/\text{Q=HI}$), all combine to produce NAND gates $\text{K10-8=LO}/\text{K10-6=HI}$, to set R-S Latch H10-8/12 ($\text{H10-8=LO}/\text{H10-12=HI}$).

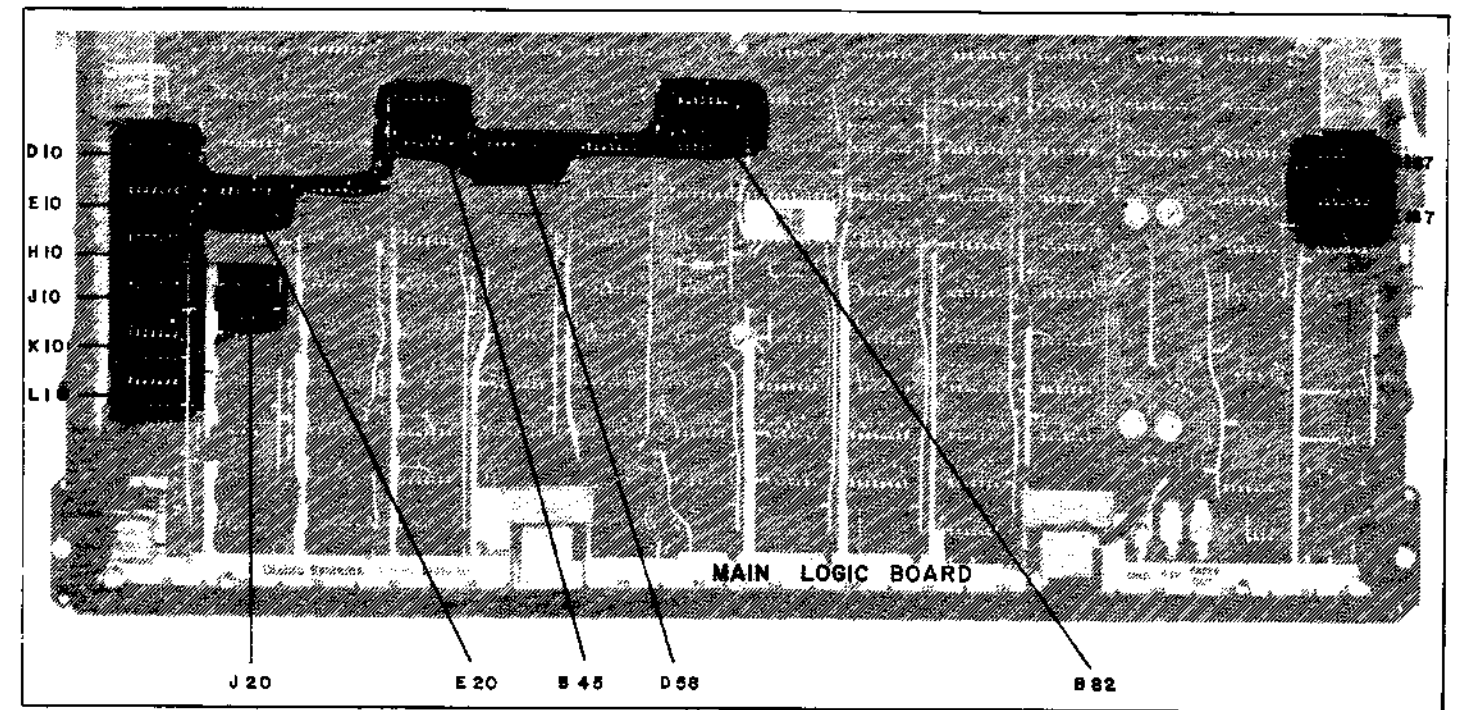

FIGURE 5-32A
COMPONENT LOCATIONS — RIBBON LIFT CONTROL LOGIC CIRCUIT

The set state of R-S Latch H10 produces +LOGIC READY=HI through OR gate B82-3. This signal is used in the print Wheel Control Logic circuit.

- (2) R-S Latch H10 *set*, plus the next CLOCK-2 pulse, *sets* FF AL ($\text{Q=HI}/\text{Q=LO}$). FF AL *set*, plus the second next CLOCK-2 pulse, *sets* FF BL ($\text{Q=HI}/\text{Q=LO}$). The set state of FF BL, plus the set state of R-S Latch H10 ($\text{-8=LO}/\text{-12=HI}$) are all applied through NAND gates E10-3 and E10-6, and through NAND gate H10-6 to start the 64 msec Ribbon Lift Timer D10. This *resets* FF CL, and +RIBBON READY goes LO. +RIBBON READY is also used in the Print Wheel Control Logic circuit.
- (3) The *set* state of FF BL (Q=HI) produces -RIBBON HOLD=LO through inverter E20-8, and -RIBBON LIFT=LO in combination with the *reset* state of FF CL (Q=HI). These two signals activate their respective drivers in the Ribbon Lift/Hold Driver circuit.
- (4) After 64 msec Ribbon Lift Timer D10 times out, and *sets* FF CL, +RIBBON READY and -RIBBON LIFT both go HI. -RIBBON HOLD=LO continues, due to the *set* state of FF BL.
- (5) The circuit will remain in this condition until the removal of $\text{-SELECT PRINTER=LO}$, $\text{-RIBBON LIFT COMMAND=LO}$, or the occurrence of a restore sequence. Any of these causes R-S Latch and FF BL to *reset*, and a recycle of the D10 Timer/FF CL sequence.
- (6) Resetting of the R-S Latch and FF BL also produces a -RIBBON STROBE=LO pulse through NAND gate E10-8, which is used in the Print Wheel Control Logic circuit.
- (7) If either the $\text{-SELECT PRINTER=LO}$ or the $\text{-RIBBON LIFT COMMAND=LO}$ signal is removed during a print cycle, the output of R-S Latch B45-6=LO will maintain ribbon lift until the print cycle has been completed.

The Ribbon Lift/Hold Driver circuit is described in Figure 5-31B. Its components may be located by referring to Figure 5-32B. Its purpose is to:

- (1) Receive the two signals, -RIBBON LIFT=LO and -RIBBON HOLD=LO from the Control Logic circuit;
- (2) First use the -RIBBON LIFT=LO signal to place approximately 30 volts across the ribbon lift solenoids when first activating the ribbon lift; and
- (3) After 64 msec, use the -RIBBON HOLD=LO signal to maintain a potential of approximately 15 volts across the ribbon lift solenoids to hold the ribbon in the up position.

The Ribbon Lift/Hold Driver circuit operates as follows:

- (1) -RIBBON LIFT=LO , applied to the base of transistor J60 turns it and driver transistor E30 *on*.

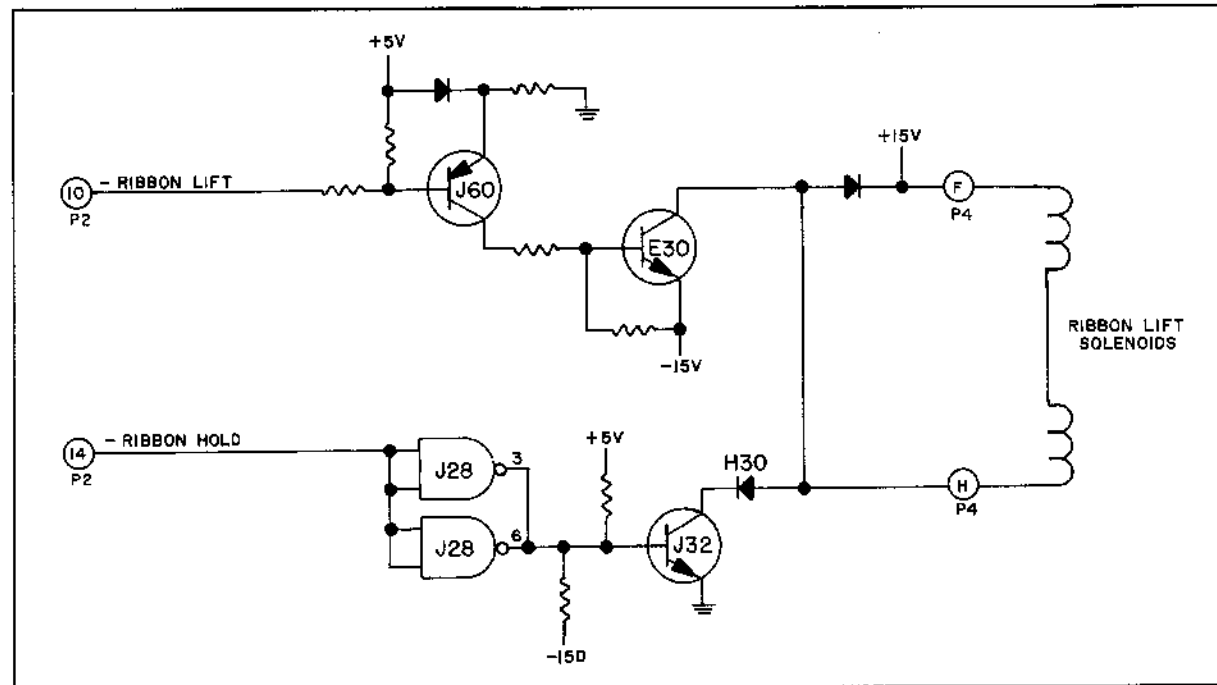

FIGURE 5-31B
CIRCUIT DIAGRAM — RIBBON LIFT/HOLD DRIVERS

- (2) Current flows from the -15 volt supply, through transistor E30, and through the ribbon lift solenoids to the +15 volt supply. This current flow, at the near 30 volt potential, strongly energizes the solenoids to pull the ribbon platform and carriage into the up position.
- (3) Simultaneously, -RIBBON HOLD=LO is applied as a HI to the base of driver transistor J32 through the paired NAND gates J28-3/6. Although transistor J32 is turned on, diode H30 is reverse biased by current flow through transistor E30, and transistor J32 is isolated.
- (4) When the Ribbon Lift Timer D10 times out, -RIBBON LIFT goes HI. This turns transistors J60 and E30 off, removing the approximately 30 volt potential from the ribbon lift solenoids. Diode H30 is no longer reverse biased.
- (5) Current now flows from ground through transistor J32, diode H30, and the solenoids to the +15 volt supply. With a potential of approximately 15 volts across them, the solenoids draw sufficient current to "hold" them activated, and hold the ribbon in the raised position.

5.9 PRINT WHEEL MOVEMENT FUNCTION AND SEQUENCE

5.9.1 Function

The function of the Print Wheel Movement circuit is to control the movement of the print wheel to position the desired character in front of the print hammer, to activate the print hammer, and to advance the ribbon. In operation, the print wheel movement function is nearly the same as the carriage movement function discussed in Section 5.7. The major differences in print wheel movement, as compared to carriage movement are: Seven data line inputs instead of eleven; the ability to determine direction of movement within the circuit; and, the addition of circuits for print hammer and ribbon advance activity.

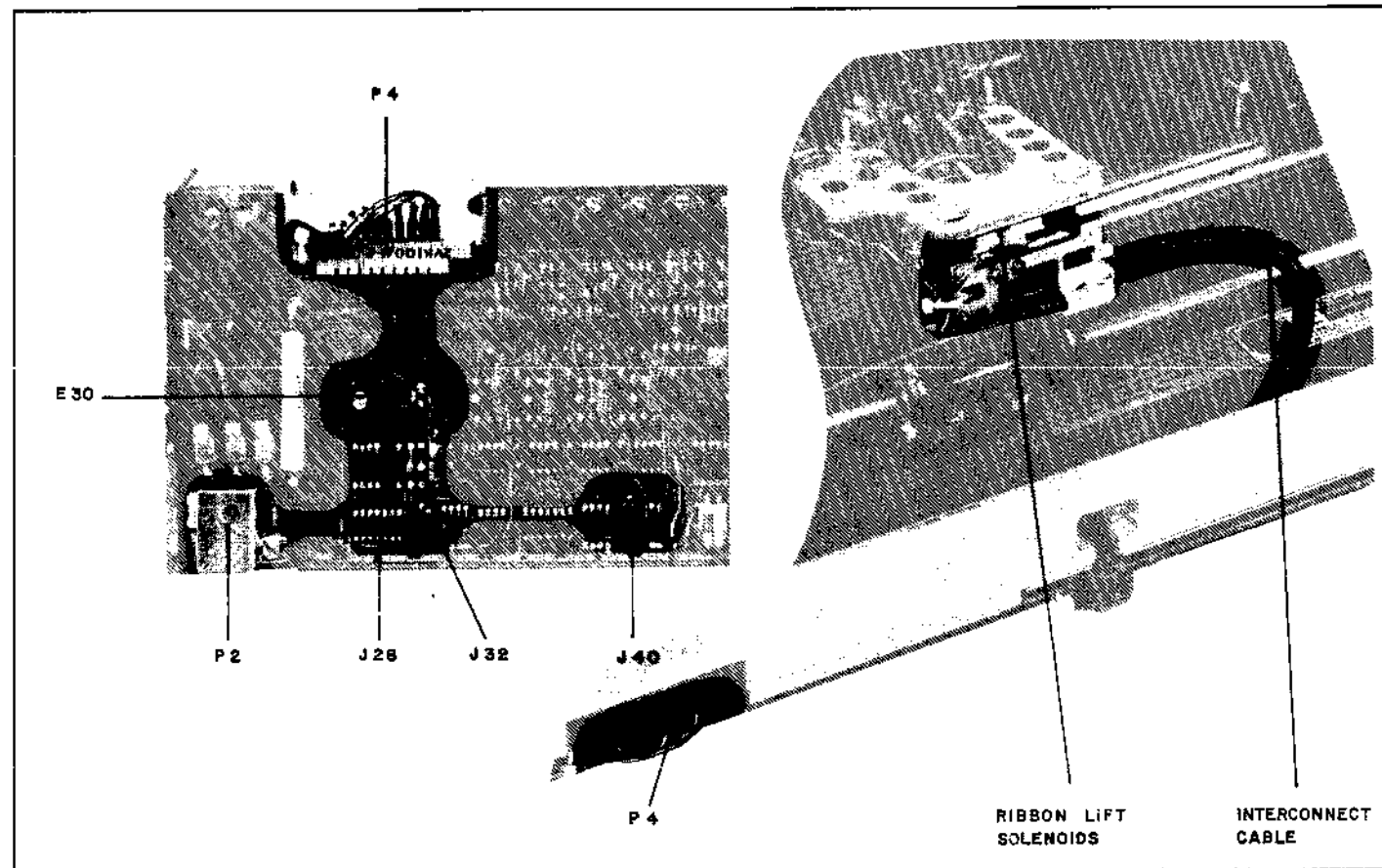

FIGURE 5-32B
COMPONENT LOCATIONS — RIBBON LIFT/HOLD DRIVERS

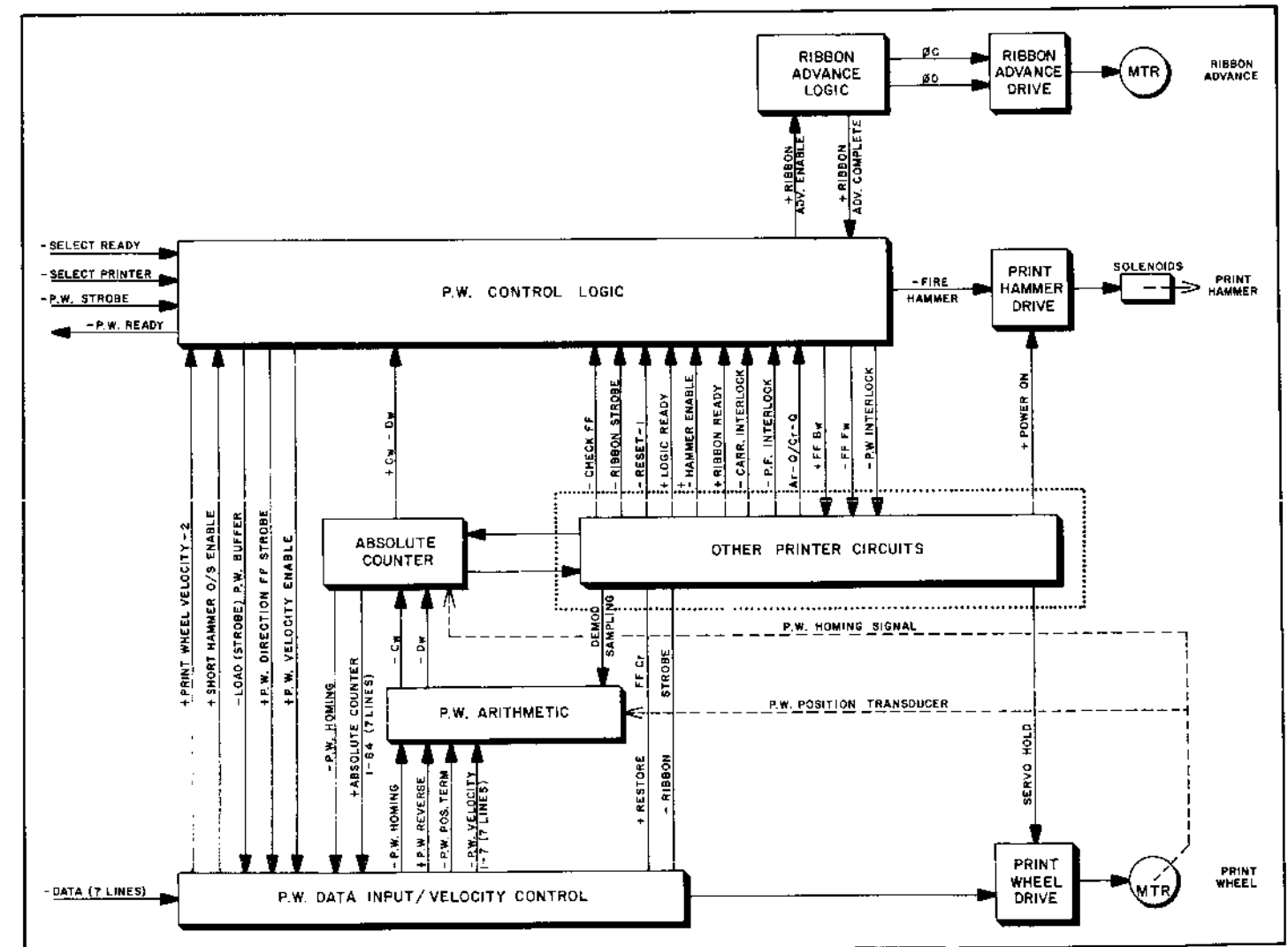

FIGURE 5-33
SIMPLIFIED BLOCK DIAGRAM — PRINT WHEEL MOVEMENT

Figure 5-33 shows a simplified block diagram of the print wheel movement circuit. The circuit diagrams in Figures 5-34A-H describe the eight parts of the print wheel movement circuit. Figures 5-35A-H show the major component locations for each part.

5.9.2 Sequence

The Print Wheel Movement circuit can be separated into eight parts; Control Logic, Data Input/Velocity Control, Arithmetic, Absolute Counter, Print Wheel Drive, Print Hammer Drive, Ribbon Advance Logic, and Ribbon Advance Drive.

The Print Wheel (P.W.) Control Logic circuit is described in Figure 5-34A. Its major component locations are shown in Figure 5-35A. Its purpose is to:

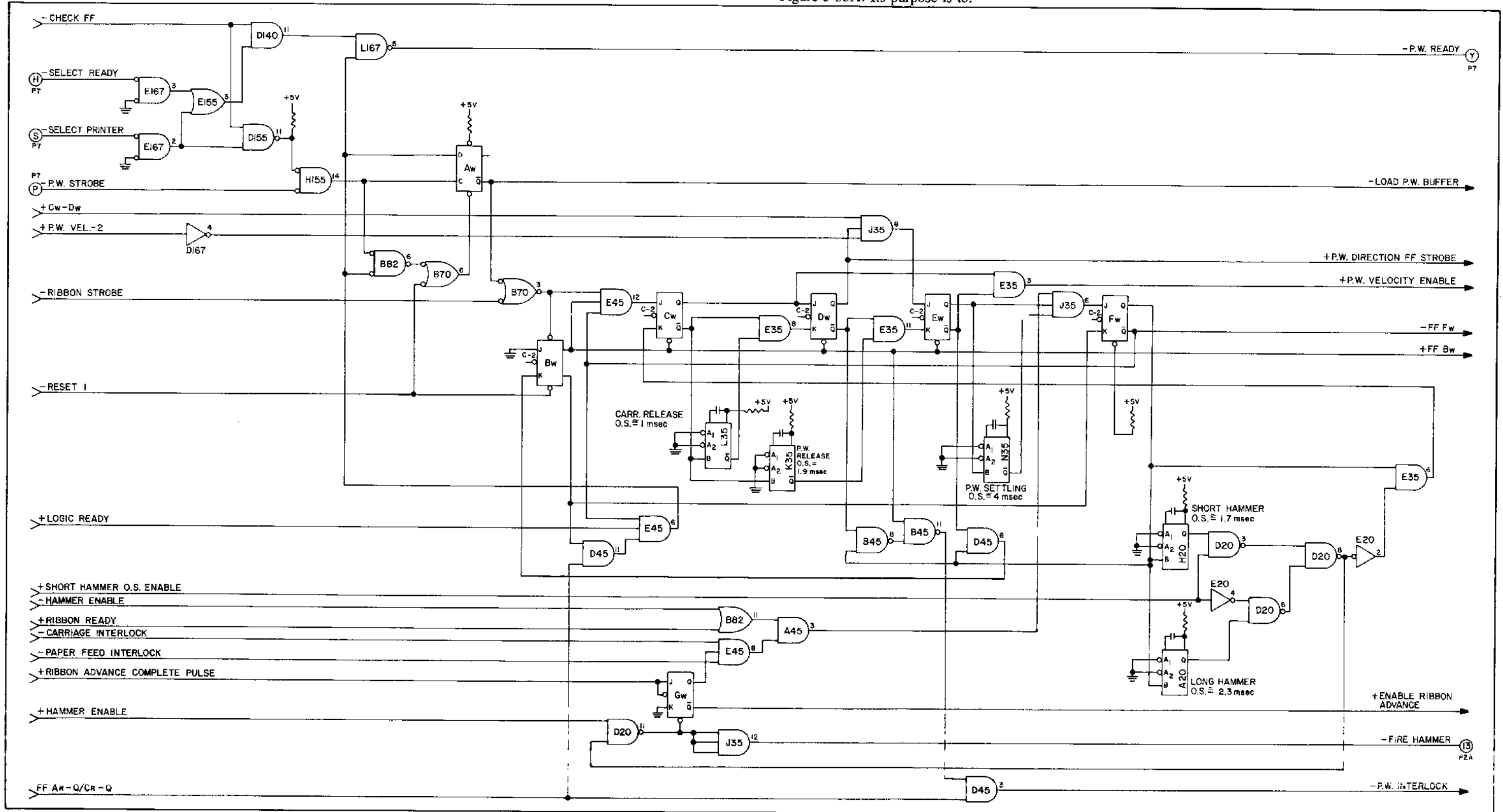

FIGURE 5-34A
CIRCUIT DIAGRAM — PRINT WHEEL CONTROL LOGIC

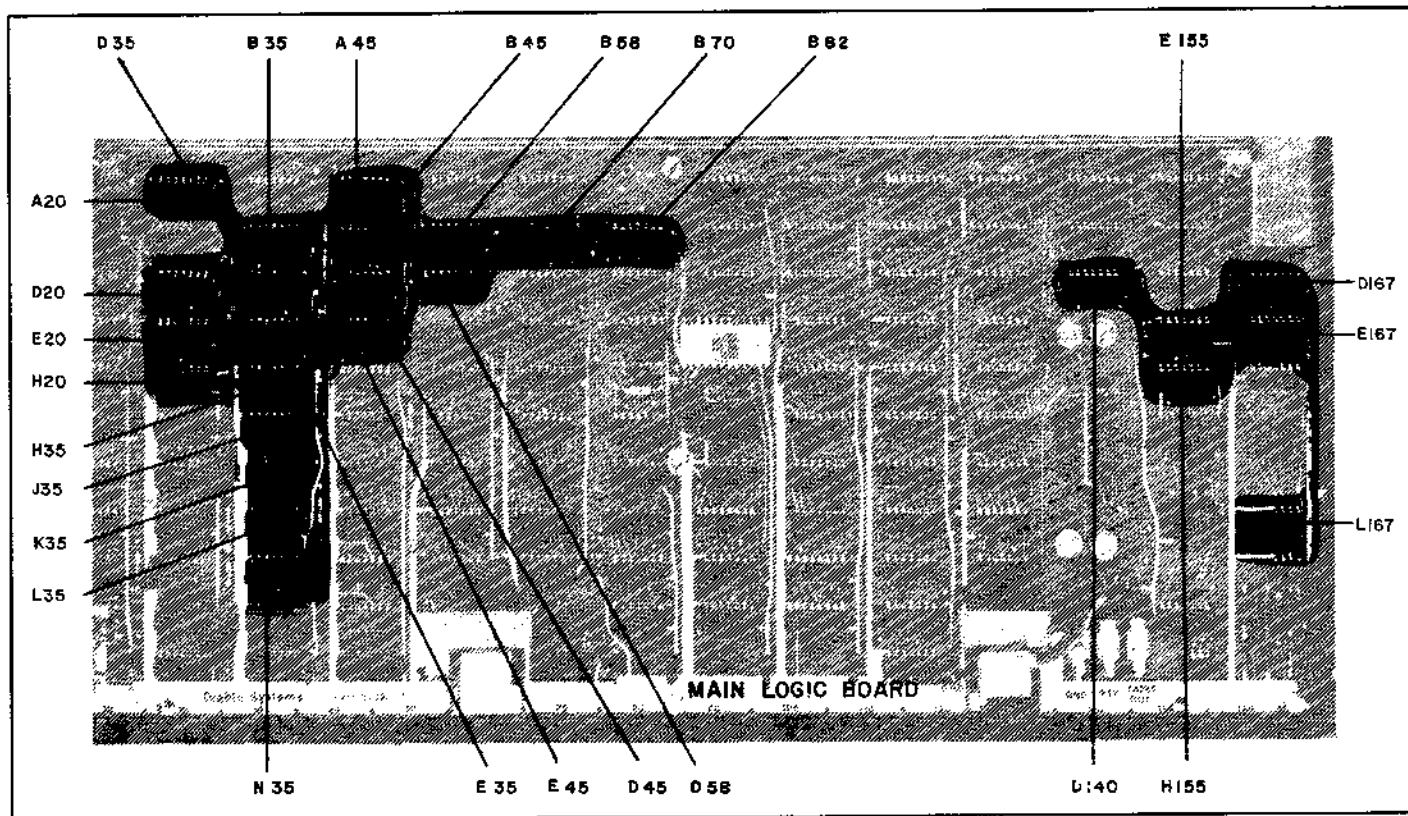

FIGURE 5-35A
COMPONENT LOCATIONS — PRINT WHEEL CONTROL LOGIC

- (1) Receive a Select Ready or a Select Printer Signal from the controller, and respond with a PRINT WHEEL READY signal if the print wheel movement circuit is in fact ready to receive and process commands;
- (2) Receive the print wheel movement command (data plus execute signal), and initiate the print wheel sequence;
- (3) Issue a signal to the controller indicating print wheel sequence in process, and/or sequence completed;
- (4) Enable the generation of print wheel velocity and direction signals in the data section;
- (5) Control print hammer activation, and strength of impulse;
- (6) Control ribbon advance;
- (7) Produce an interlock signal to inhibit carriage and/or paper feed movement during print hammer activation (firing);
- (8) Inhibit its own print hammer activity during a previously initiated carriage or paper feed movement sequence;
- (9) Disable its own operation upon receipt of a CHECK signal and reset its logic upon receipt of a RESTORE signal; and
- (10) Reset its logic, release its interlock signal, and issue a PRINT WHEEL READY signal when the print wheel sequence has been completed.

Operation of the P.W. Control Logic circuit is as follows:

- (1) Beginning in the quiescent state, all flip-flops are in the *reset* condition ($Q=LO/\bar{Q}=HI$), and all inputs except clocks are HI. The $-PW$ READY and $-PW$ INTERLOCK output lines are also HI.
- (2) A $-SELECT$ READY= LO pulse applied to NOR gate E167-3 has the same result as in previously discussed circuits.
- (3) A $-SELECT$ PRINTER= LO signal enables the printer to respond to commands from the controller. From NOR gate E167-2, the now $+SELECT$ PRINTER signal is applied to OR gate E155-3, where it follows the same sequence as the $-SELECT$ READY signal to produce the $-PW$ READY= LO signal, and to NAND gate D155-11 for comparison with the $-CHECK$ FF status. If both are HI (printer is not in check condition), a LO is passed to NOR gate H155-14. H155-14 is enabled, and the print wheel logic is ready to receive commands.
- (4) The controller, having received the $-PW$ READY= LO signal, first places print wheel data (ASCII character code for the next character to be printed) on the 7 low order data lines and then, after a minimum 200 usec delay, places a

LO signal on the $-PW$ STROBE input line. This low is applied to enabled NOR gate H155-14. The resultant H155-14= HI is applied to the clock input of D type flip-flop Aw. FF Aw sets with the leading edge of this HI, and its \bar{Q} output goes LO. $Aw-\bar{Q}=LO$ strobes the print wheel data register to enter the print wheel data ($-LOAD$ PW BUFFER signal), and places a LO on OR gate B70-3. B70-3 goes LO, to force set FF Bw.

- (5) FF Bw set produces $Bw-Q=HI/\bar{Q}=LO$. FF $Bw-\bar{Q}=LO$:
 - (a) Disables $-PW$ READY ($=HI$) through AND gates D45-11, E45-6, and NAND gate L167-5; and
 - (b) Enables FF Aw to reset through AND gates D45-11, E45-6, B82-6, and OR gate B70-6. FF Aw resets then with the trailing edge of the $-PW$ STROBE pulse.
The Output of AND gate E45-6 is referred to as $+PW$ READY. FF $Bw-Q=HI$:
 - (a) Produces $-PW$ INTERLOCK= LO through NAND gate B45-11, which has been enabled by the reset state of FF's Dw and Fw ($B45-11=LO$), and through OR gate D45-3;
 - (b) Is supplied to the Ribbon Lift circuit; and
 - (c) Is applied to AND gate E45-12 where, in conjunction with the reset states of FF's Fw and Aw, it enables FF Cw to set with the next CLOCK-2 pulse.
- (6) FF Cw set produces $Cw-Q=HI/\bar{Q}=LO$. FF $Cw-Q=HI$:
 - (a) Enables FF Dw to set with the next CLOCK-2 pulse; and
 - (b) Is Nanded at gate E35-3 with reset FF $Ew-\bar{Q}=HI$ to produce the $+PW$ VELOCITY ENABLE= HI signal, which enables all the velocity gates in the Data Input/Velocity Control circuit.
FF $Cw-\bar{Q}=LO$, through AND gate E35-8, ensures that FF Dw will remain set until FF Cw resets, and the Carr./P.F. one-shot times out.
- (7) FF Dw set produces FF $Dw-Q=HI/\bar{Q}=LO$. FF $Dw-Q=HI$ is supplied to the Data Input/Velocity Control circuit as the $+PW$ DIRECTION FF STROBE signal, which enables print wheel direction of rotation control.
- (8) With print wheel velocity and direction circuits enabled, the print wheel begins to move. As it moves, a $+Cw-Dw$ signal is generated which is applied to AND gate J35-8. $+CW-DW$, in conjunction with FF $Dw-Q=HI$, enables gate J35-8. A third input, called $+PW$ VELOCITY 2, is also applied to gate J35-8 through inverter D167-4. $+PW$ VELOCITY 2 is HI as long as the print wheel has not reached its commanded position. When the print wheel has moved close to the commanded position (moving at velocity 2, and within $3/8$ of one position of its destination), $+PW$ VELOCITY 2 goes LO which, through inverter D167-4, applies a HI to J35-8. J35-8 goes HI, enabling FF Ew to set with the next CLOCK-2 pulse.
- (9) FF Ew set produces FF $Ew-Q=HI/\bar{Q}=LO$. FF $Ew-Q=HI$ is applied to AND gate J35-6, and to P.W. Settling one-shot N35 which begins to run. In combination with FF $Ew-Q=HI$, gate J35-6 is enabled by the following conditions, through OR gate B82-11, and AND gates E45-8 and A45-3:
 - (a) The ribbon must have been lifted into place ($-HAMMER$ ENABLE= LO , and $+RIBBON$ ADVANCE= HI).
 - (b) The carriage and paper feed functions must be at rest ($-CARR.$ INTERLOCK= HI , and $-P.F.$ INTERLOCK= HI).
 - (c) The ribbon advance function must be at rest (FF $Gw-Q=HI$).

With these conditions satisfied, the time-out of one-shot N35 ($N35=\bar{Q}=HI$) passes enabled gate J35-6 to set FF Fw.

FF $Ew-\bar{Q}=LO$ disables AND gate E35-3, to produce $+PW$ VELOCITY ENABLE= LO which disables all the velocity gates in the Data Input/Velocity Control circuit.
- (10) FF Fw set produces FF $Fw-Q=HI/\bar{Q}=LO$. $Fw-Q=HI$ is applied to both Short Hammer and Long Hammer one-shots. They begin to run, and their Q outputs go HI and remain HI until they time out. The Short Hammer one-shot, H20, times out in approximately 1.7 msec, the Long Hammer one-shot, in 2.3 msec. The shorter time for the Short Hammer one-shot reduces the print hammer drive signal for certain characters. The signal $+SHORT$ HAMMER O.S. ENABLE= LO , through inverter E20-4, enables NAND gate D20-6, through which Long Hammer one-shot A20-Q= HI places a LO on NAND gate D20-8. $+SHORT$ HAMMER O.S. ENABLE= LO , in conjunction with Short Hammer O.S. H20-Q= HI through NAND gate D20-3, places a HI on D20-8. In this situation, the D20-6= LO controls the gate, to produce D20-8= HI for 2.3 msec. When $+SHORT$ HAMMER O.S. ENABLE= HI , D20-6 will be HI while D20-3 is LO and controlling the gate. Then D20-8 will be HI for 1.7 msec.
FF $Fw-\bar{Q}=LO$ is supplied to the Ribbon Lift circuit as $-FF$ Fw= LO , and also disables AND gate E45-12 to enable FF Cw to reset.

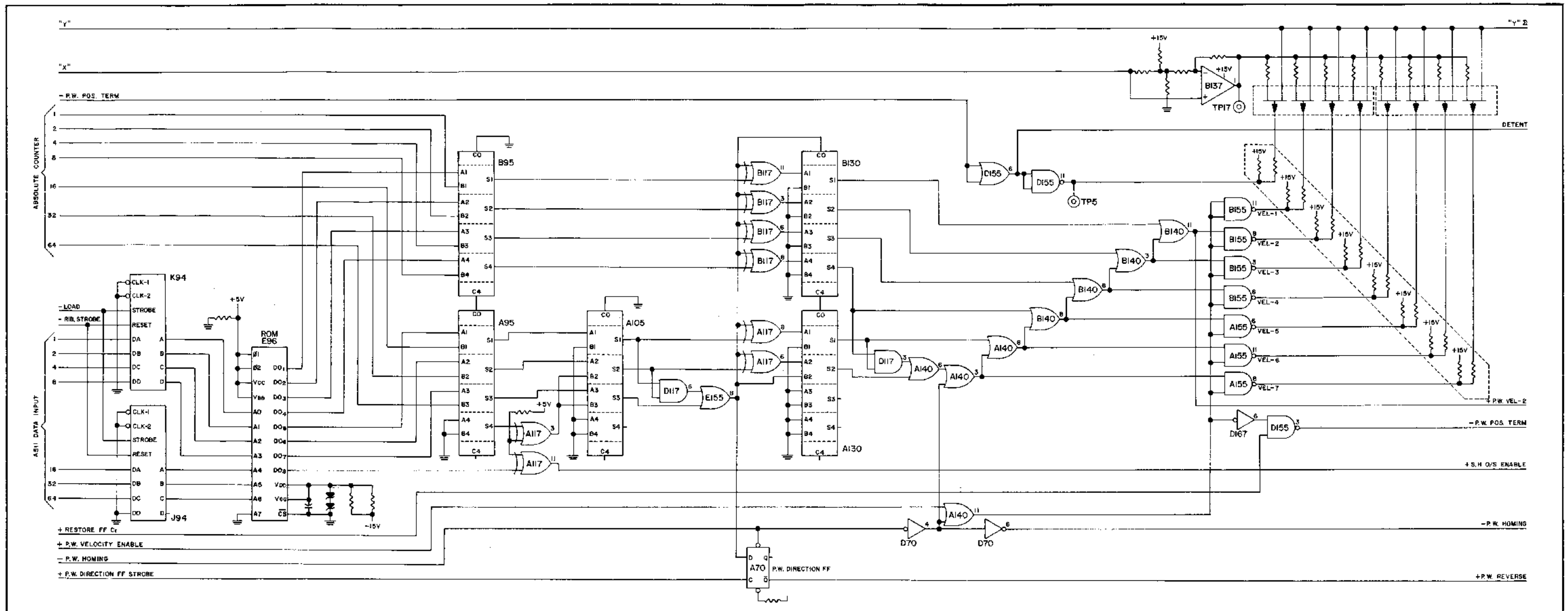

FIGURE 5-34B
CIRCUIT DIAGRAM — PRINT WHEEL INPUT/VELOCITY CONTROL

NAND gate D20-8=HI, through NAND gate D20-11 which has been enabled by +HAMMER ENABLE=HI, resets FF Gw, and through AND gate J35-12 produces -FIRE HAMMER=LO to activate the print hammer drive circuit.

- (11) When the enabled hammer one-shot times out, D20-8 goes LO to disable the hammer fire. This LO becomes HI through inverter E20-2, and combines with FF Fw-Q=HI through AND gate E35-6 to reset FF Cw.
- (12) FF Cw reset fires the Carriage/Paper Feed and P.W. Release one-shots L35 and K35. The time-out (approx. 1 msec) of Carr./P.F. O.S. L35 resets FF Dw, while the time-out (approx. 1.9 msec) of P.W. Release O.S. K35 enables FF Ew to reset with the next CLOCK-2 pulse. The resetting of FF Dw produces -P.W. INTERLOCK=HI, to allow carriage and paper feed operation. The resetting of FF Ew enables FF Bw, through AND gate D45-8, to reset with the next CLOCK-1 pulse. The resetting of FF Bw resets FF Fw, and generates -PW READY=LO, signaling the end of the print wheel cycle.

The Print Wheel Data Input/Velocity Control circuit is described in Figure 5-34B. Its major component locations are shown in Figure 5-35B. Its purpose is:

- (1) Receive data, in ASCII format, representing the next (or commanded) print wheel position, and the output of the Absolute Counter circuit, in standard binary code format, representing the present print wheel position and;
- (2) Receive and use signals from other circuits to control its operation and;

- (3) Process data and Absolute Counter inputs to produce appropriate speed and direction outputs to the drive and arithmetic circuits; and
- (4) Supply signals for use in other circuits to help in coordinating operations.

Operation of the Print Wheel Data Input/Velocity Control circuit is as follows:

- (1) The controller presents data (ASCII format) to the data input registers J94 and K94, representing the next character to be printed. After a minimum 200 usec settling delay, the controller issues a print wheel strobe command which, after passing through the control logic, arrives at the registers as -LOAD PW BUFFER=LO, to cause the ASCII data to enter (load) into the registers. At the end of the strobe pulse, this ASCII data is presented to the MOS/LSI "ROM" (ready-Only-Memory) E96.

Figure 5-36 shows the standard Diablo print wheel, and identifies each print character in terms of its wheel position ("petal") number. Table 5-2A then identifies the print characters and their print wheel positions in terms of their ASCII coding, while Table 5-2B lists the ASCII coding in terms of the print wheel position.

- (2) The adjoining Absolute Counter circuit provides a 7-line input giving present print wheel position (petal number) in binary form. The E96 ROM receives the ASCII data, and converts it to a 2's complimented binary "word" representing the next, or commanded, print wheel position (the ROM output for position "O" is binary 32). These two "words," listed together in Table 5-2C for each print wheel position, are presented to Adders A95/B95 (ROM

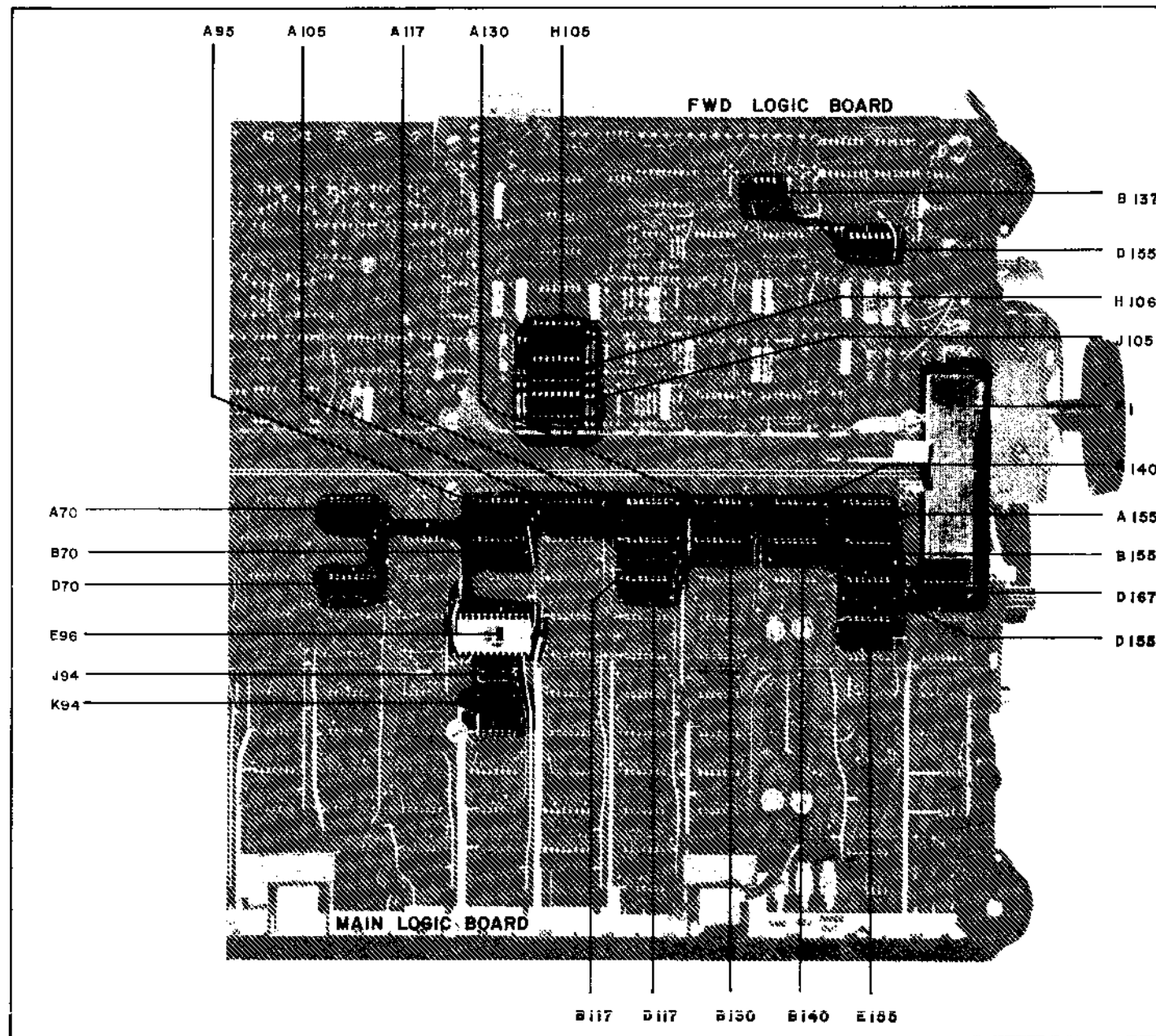

FIGURE 5-35B

COMPONENT LOCATIONS — PRINT WHEEL DATA INPUT/VELOCITY CONTROL CIRCUIT

“word” to A inputs, Abs. Ctr. “word” to B inputs). As a part of its operation, the E96 ROM also provides an output to the Control Logic circuit called +SHORT HAMMER O/S ENABLE. This signal, when LO, causes the logic to reduce the force of the print hammer stroke for those characters which require less energy than the others to produce equal print quality.

- (3) Adders A95/B95 perform a straight binary addition of the two inputs. The output of high count Adder A95-S4 is applied to EXCLUSIVE-OR gate A117-3. If the internal computation within Adder A95 has resulted in a summation produce less than 96, gate A117-3 causes Adder A105 to add a count value of 96 to the result. The output of Adder A105 is then presented to the EXCLUSIVE-OR gate 2's complementing net (A117-6/8, B117-3/6/8/11) along with the output of Adder B95. If the output of Adder A105 equals 48 or more, the network of AND gate D117-6/OR gate E155-8 applies a LO to PW Direction FF A70-D, and enables the 2's complementing net, while also adding a count value of 32. FF A70 will then set when +PW DIRECTION FF STROBE=HI, and the +PW REVERSE=HI output will cause reverse (CCW) print wheel rotation for the shortest distance of travel to the commanded position.
- (4) Adders A130/B130 receive the count from the net, and provide difference count inputs to the velocity gate network to

control the velocity summation FET's. As with the carriage movement functions, the speed of print wheel movement is directly proportional to the distance to be moved. The greater the distance, the higher the velocity required, and therefore the greater the number of velocity gates needed. With all the gates enabled by the Control Logic circuit, Table 5-3 lists the velocity gates used in terms of the Difference Count (number of print wheel positions between the present and commanded positions).

TABLE 5-3
PRINT WHEEL VELOCITY GATE SEQUENCE

Diff. Count	Velocity Gates Turned On
1	2
2 or 3	2, 3
4 to 7	2, 3, 4
8 to 15	2, 3, 4, 5
16 to 23	2, 3, 4, 5, 6
24 or more	2, 3, 4, 5, 6, and 7

Note that Velocity-1 gate is fully turned on by the +PW VELOCITY ENABLE=HI signal. VEL-1=LO represents the minimum velocity signal to the summation FET's, and is removed whenever +PW VEL ENABLE=LO (Diff. Count=0).

- (5) Following are examples of typical print wheel movement sequences.
 - (a) PW present position = 0 (80) = 1 0 1 0 0 0 0 AC
 Commanded position = D (22) = 1 1 0 1 0 1 0 ROM
 1. A95/B95 add = 58 0 1 1 1 0 1 0 +1
 2. With carry bit, A105/B95 = 0 1 1 1 0 1 0 +1
 3. A105/B95 out = 48, FF A70 is set, add C 32.
 A130/B130 out = 38 0 1 0 0 1 1 0
 A130-6=HI enables VEL-7 and all lower gates.
 The print wheel will move CW 38 positions beginning with the highest velocity.
 - (b) PW present position = D (22) = 0 0 1 0 1 1 0 AC
 Commanded position = i (85) = 0 1 0 1 0 1 1 ROM
 1. A95/B95 add = 57 0 1 1 1 0 0 1
 2. Without carry, A105
 adds 96 1 1 0 0 0 0 0
 0 0 1 1 0 0 1 +1
 3. A105/B95 output = 48,
 FF A70 resets to change
 PW direction, 32 is NOT
 added. A130/B130 out=33 0 1 0 0 0 0 1
 A130-6=HI enables VEL-7 and all lower gates. FF A70-Q=HI produces PW REVERSE=HI to reverse the direction of print wheel movement. The print wheel will move CCW 33 positions, beginning at the highest velocity.
 - (c) PW present position = i (85) = 1 0 1 0 1 0 1 AC
 Commanded position = p (90) = 0 1 0 0 1 1 0 ROM
 1. A95/B95 add = 115 1 1 1 0 0 1 1
 2. Without carry, A105
 adds 96 1 1 0 0 0 0 0
 1 0 1 0 0 1 1
 3. A105/B94 output = 48,
 FF A70 sets to change PW
 direction, add 32 to A130
 A130/B130 out = 5 0 0 0 0 1 0 1
 B130-2=HI enables VEL-4 and all lower gates. The print wheel will move CW 5 positions.

Anytime an input other than a valid ASCII format is presented to the E96 ROM, this device will issue a 2's complimented command to move the print wheel to the zero (w) position.

- (6) A signal is generated in the print wheel arithmetic circuit called “X VELOCITY COMMAND REFERENCE.” This signal is a reference voltage level which is developed in the arithmetic circuit, and represents print wheel movement. “X” is amplified in B137, and applied to the source connections of the summation network FET's H135/J135, through a series of parallel resistors whose values get progressively smaller for each higher order velocity gate. A second signal from the same source, called “Y FEEDBACK REFERENCE,” is applied to the drain connection of these same FET's, as a common connection. This line is also the output to the print wheel drive circuit.

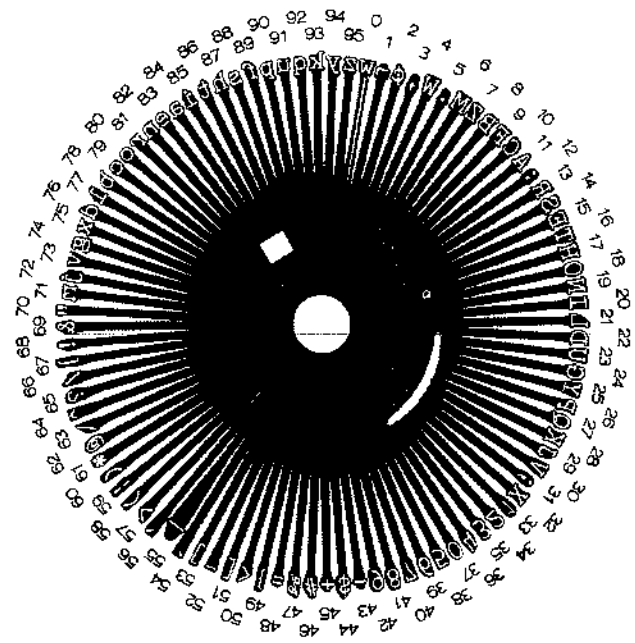

FIGURE 5-36
PRINT WHEEL ARRANGEMENT

TABLE 5-2A
PRINT WHEEL ARRANGEMENT BY ASCII CODE

64 32 16 8 4 2 1	64 32 16 8 4 2 1	64 32 16 8 4 2 1	
0100000	2 ¢	1000000 62 @	1100000 56 ' **
0100001	68 !	1000001 11 A	1100001 84 a
0100010	70 ***	1000010 8 B	1100010 78 b
0100011	46 #	1000011 10 C	1100011 79 c
0100100	44 \$	1000100 22 D	1100100 76 d
0100101	47 %	1000101 15 E	1100101 83 e
0100110	69 &	1000110 9 F	1100110 89 f
0100111	54 ***	1000111 24 G	1100111 74 g
0101000	60 (1001000 17 H	1101000 87 h
0101001	58)	1001001 20 I	1101001 85 i
0101010	61 *	1001010 29 J	1101010 72 j
0101011	45 +	1001011 28 K	1101011 93 k
0101100	3 ***	1001100 21 L	1101100 77 l
0101101	43 -	1001101 6 M	1101101 71 m
0101110	5 **	1001110 19 N	1101110 82 n
0101111	66 /	1001111 18 O	1101111 80 o
0110000	37 0	1010000 26 P	1110000 90 p
0110001	33 1	1010001 27 Q	1110001 92 q
0110010	34 2	1010010 13 R	1110010 81 r
0110011	35 3	1010011 14 S	1110011 88 s
0110100	36 4	1010100 16 T	1110100 85 t
0110101	38 5	1010101 23 U	1110101 91 u
0110110	39 6	1010110 30 V	1110110 73 v
0110111	40 7	1010111 4 W	1110111 0 w ^{ooo}
0111000	141 8	1011000 32 X	1111000 75 x
0111001	42 9	1011001 25 Y	1111001 94 y
0111010	12 :	1011010 7 Z	1111010 95 z
0111011	31 ;	1011011 53 [1111011 49 }
0111100	57 <	1011100 63 \	1111100 59
0111101	48 =	1011101 51]	1111101 67 }
0111110	50 >	1011110 64 ^	1111110 52 ~
0111111	65 ?	1011111 55 -**	1111111 1 7

** = Characters which receive short hammer stroke
ooo = Zero Position

TABLE 5-2B
PRINT WHEEL ARRANGEMENT BY CHARACTER "PETAL"

64 32 16 8 4 3 1	64 32 16 8 4 2 1	64 32 16 8 4 2 1	
0 w	1110111 ^{ooo}	32 X 1011000	64 ^ 1011110**
1 7	1111111	33 I 0110001	65 ? 0111111
2 ¢	0100000	34 2 0110010	66 / 0101111
3 ,	0101100**	35 3 0110011	67 { 1111101
4 W	1010111	36 4 0110100	68 ! 0100001
5 .	0101110**	37 0 0110000	69 & 0100110
6 M	1001101	38 5 0110101	70 " 0100010**
7 Z	1011010	39 6 0110110	71 m 1101101
8 B	1000010	40 7 0110111	72 j 1101010
9 F	1000110	41 8 0111000	73 v 1110110
10 C	1000011	42 9 0111001	74 g 1100111
11 A	1000001	43 - 0101101	75 x 1111000
12 :	0111010	44 \$ 0100100	76 d 1100100
13 R	1010010	45 + 0101011	77 l 1101100
14 S	1010011	46 # 0100011	78 b 1100010
15 E	1000101	47 % 0100101	79 c 1100011
16 T	1010100	48 = 0111101	80 o 1101111
17 H	1001000	49 } 1111011	81 r 1110010
18 O	1001111	50 > 0111110	82 n 1101110
19 N	1001110	51] 1011101	83 e 1100101
20 I	1001001	52 ~ 1111110**	84 a 1100001
21 L	1001100	53 [1011011	85 i 1101001
22 D	1000100	54 ' 0100111**	86 t 1110100
23 U	1010101	55 - 1011111**	87 h 1101000
24 G	1000111	56 ` 1100000**	88 s 1110011
25 Y	1011001	57 < 0111100	89 f 1100110
26 P	1010000	58) 0101001	90 p 1110000
27 Q	1010001	59 1111100	91 u 1110101
28 K	1001011	60 (0101000	92 q 1110001
29 J	1001010	61 * 0101010	93 k 1101011
30 V	1010110	62 @ 1000001	94 y 1111001
31 ;	0111011	63 \ 1011100	94 z 1111010

** = Characters which receive short hammer pulse
ooo = Zero Position

TABLE 5-2C
"ROM" and ABSOLUTE COUNTER OUTPUTS TO A95/B95 ADDERS

0	0000000	32	0111000	64	1000000
1	0000001	33	0100001	65	1000001
2	0000010	34	0100010	66	1000010
3	0000011	35	0100011	67	1000011
4	0000100	36	0100100	68	0000100
5	0000101	37	0100101	69	0000101
6	0000110	38	0100110	70	0000110
7	0000111	39	0100111	71	0000111
8	0001000	40	0101000	72	0001000
9	0001001	41	0101001	73	0001001
10	0001010	42	0101010	74	0001010
11	0001011	43	0101011	75	0001011
12	0001100	44	0101100	76	0001100
13	0001101	45	0101101	77	0001101
14	0001110	46	0101110	78	0001110
15	0001111	47	0101111	79	0001111
16	0010000	48	0110000	80	0010000
17	0010001	49	0110001	81	0010001
18	0010010	50	0110010	82	0010010
19	0010011	51	0110011	83	0010011
20	0010100	52	0110100	84	0010100
21	0010101	53	0110101	85	0010101
22	0010110	54	0110110	86	0010110
23	0010111	55	0110111	87	0010111
24	0011000	56	0111000	88	0011000
25	0011001	57	0111001	89	0011001
26	0011010	58	0111010	90	0011010
27	0011011	59	0111011	91	0011011
28	0011100	60	0111100	92	0011100
29	0011101	61	0111101	93	0011101
30	0011110	62	0111110	94	0011110
31	0011111	63	0111111	95	0011111

- (7) Those summation FET's whose control gates are LO (respective velocity gate turned on), will turn on. This gates "X" voltage on to the "Y" line through the parallel resistors, with the Algebraic Sum being proportional to the distance to be traveled by the print wheel.

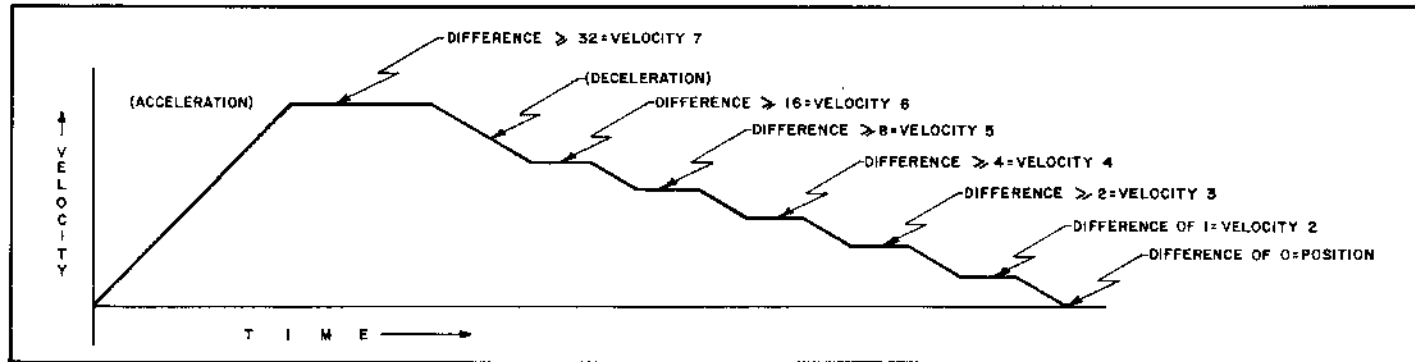

FIGURE 5-37
PRINT WHEEL SERVO SPEED SELECTION

- (8) Print wheel movement then results in the absolute counter output changing. As the difference between this and the ROM output diminishes, the highest order velocity gates left on are disabled, fewer and fewer summations FET's are left in the circuit, resulting in a drive signal which rises to some high level at the start of a movement, and then diminishes toward zero in steps, as outlined in Figure 5-37.
- (9) When the print wheel has reached the commanded position (absolute counter and ROM difference = 0), and has stopped, a -POS TERM=LO signal is produced in the control logic circuit. This LO is applied to buffer OR gate D155-6. D155-6=LO is passed to the print wheel arithmetic circuit for generation of appropriate "X" and "Y" voltages, and to turn on one summation FET through NAND gate D155-11. The resultant drive signal "locks" the print wheel in a detent condition.

The Print Wheel Arithmetic circuit is described in Figure 5-34C. Its major components may be located by referring to figure 5-35C. It is similar to the Carriage Arithmetic circuit, both in design and in operation. Its purpose is to:

- (1) Generate two 480KHz modulated ac signals (θA and θB), phase shifted 90° from each other, through a rotary transducer mounted on the print wheel motor;
- (2) Use these two θA and θB signals, plus a +REVERSE signal from the Print Wheel Data Input circuit, to produce the following:
 - a) -Cw and -Dw pulse trains for use in the Absolute Counter circuit.
 - b) "X VELOCITY COMMAND REFERENCE" and "Y VELOCITY FEEDBACK" waveforms for use in the Data Input/Velocity Control circuit.
 - c) Forms of the "X" and "Y" waveforms for use in detenting the print wheel motor.

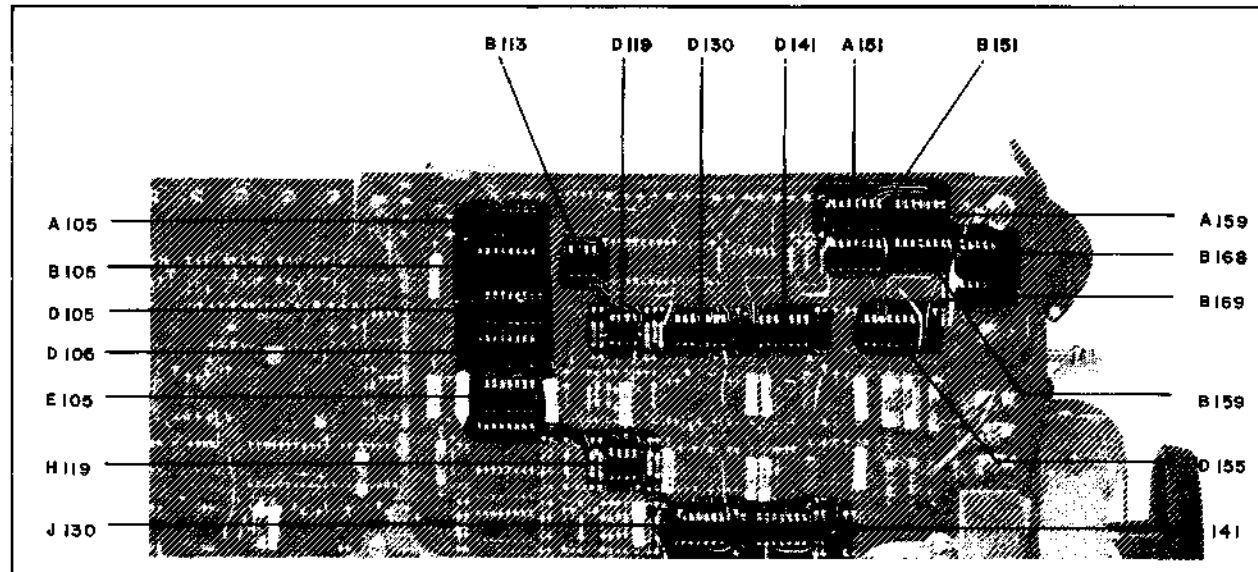

FIGURE 5-35C
COMPONENT LOCATIONS — PRINT WHEEL ARITHMETIC CIRCUIT

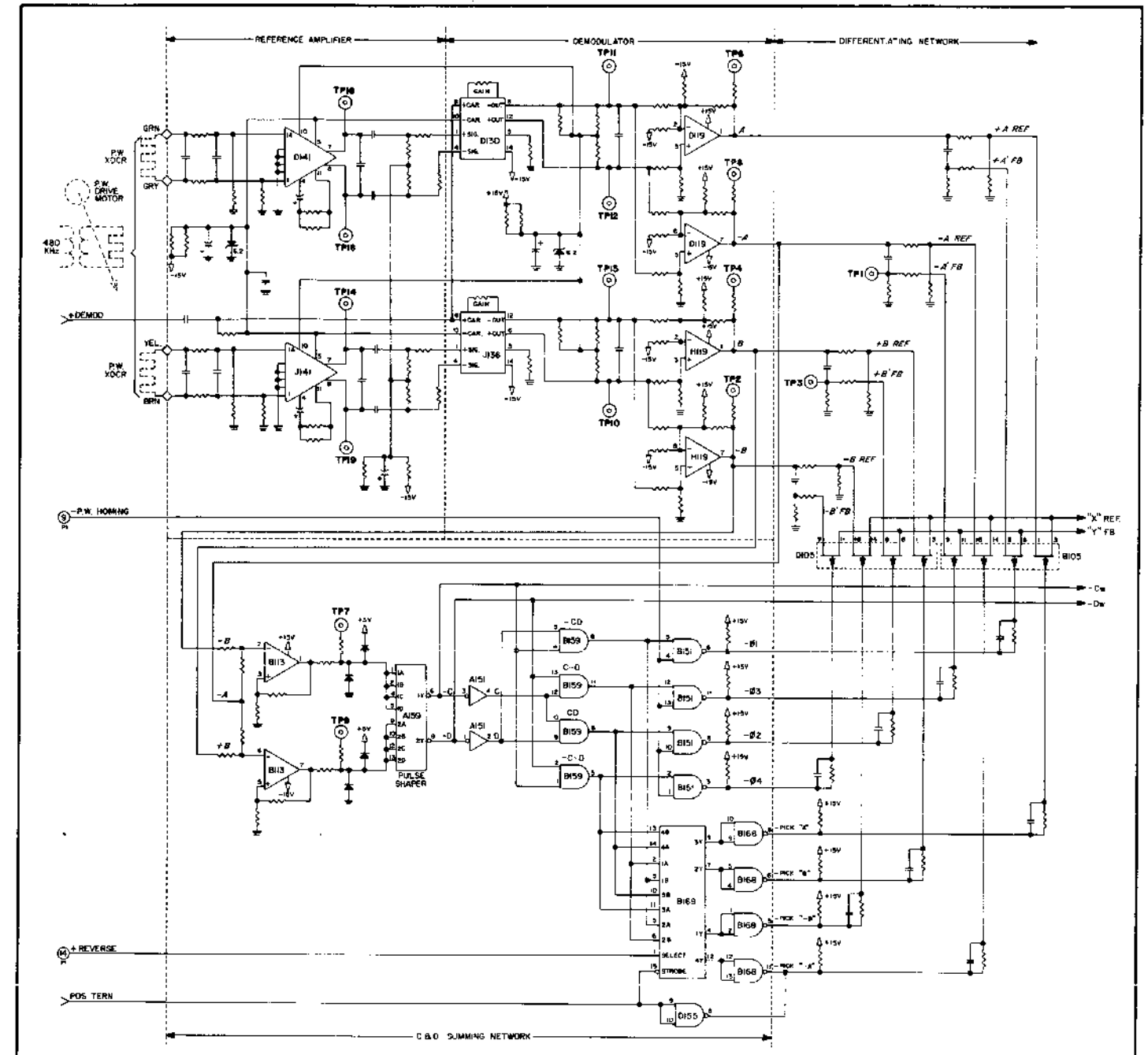

FIGURE 5-34C
CIRCUIT DIAGRAM — PRINT WHEEL ARITHMETIC

Operation of the Print Wheel Arithmetic Servo circuit is as follows:

- (1) Whenever power is applied to the printer, a 480KHz carrier signal is generated, and applied to the primary of an air core transformer mounted on a plate over the free end of the print wheel servo motor shaft. The secondary of this transformer is mounted on the rotary member of a shaft position transducer, which is fastened to the free end of the motor shaft. The stationary member of the transducer is mounted on the end of the motor housing. Except for its smaller physical size, this transducer operates identically to that used on the carriage drive motor.

As shown in Figure 5-23 (Carriage Movement Section 5.7), the "winding" of the rotary transducer member is symmetrical, while the "winding" of the stationary member is not. The Stationary "winding" is divided into eight segments, which are alternately connected together into two groups of four segments each. The four segments of one group are displaced laterally from those of the other group a distance equal to one half winding width, which is equivalent to 90° of electrical phase difference. The output of the groups are labeled θA and θB .

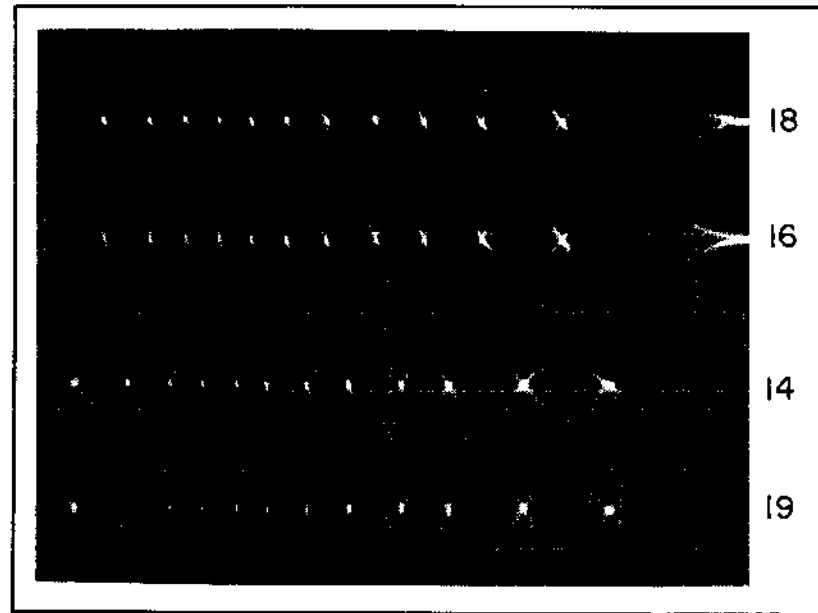

FIGURE 5-38
PRINT WHEEL ARITHMETIC WAVEFORMS

Each winding group is coupled to the input of a differential amplifier, D141 for θA , and J141 for θB . These amplifiers each have a normal and an inverted output. Figure 5-38 shows the waveforms present at the outputs of these two amplifiers, at test points TP18, 16, 14, and 19, for one print wheel movement cycle. These waveforms illustrate the phase relationship between the top θA signals and the bottom θB signals. The right hand end of these waveforms show the static conditions present after the motor has stopped. The system is arranged so that when the motor is in a normal stop (or detent) position, θB transducer coupling will be maximum, and θA coupling will be minimum. As the motor starts to rotate, the 480KHz θA and θB signals vary in amplitude, due to the changing relationship between rotor and stator transducer "windings", and the frequency of this amplitude variation (or modulation) will be a measure of the velocity of the motor.

- (2) The outputs of the D141 and J141 (connections 7 and 8) pass through dc offset networks to a pair of demodulator modules, D130 and J130. Demodulation removes the 480KHz component of the input signals, leaving the low frequency am component. Amplifier modules D119 and H119 amplify and invert the four demodulated phase related signals, now designated +A, -A, +B, and -B.

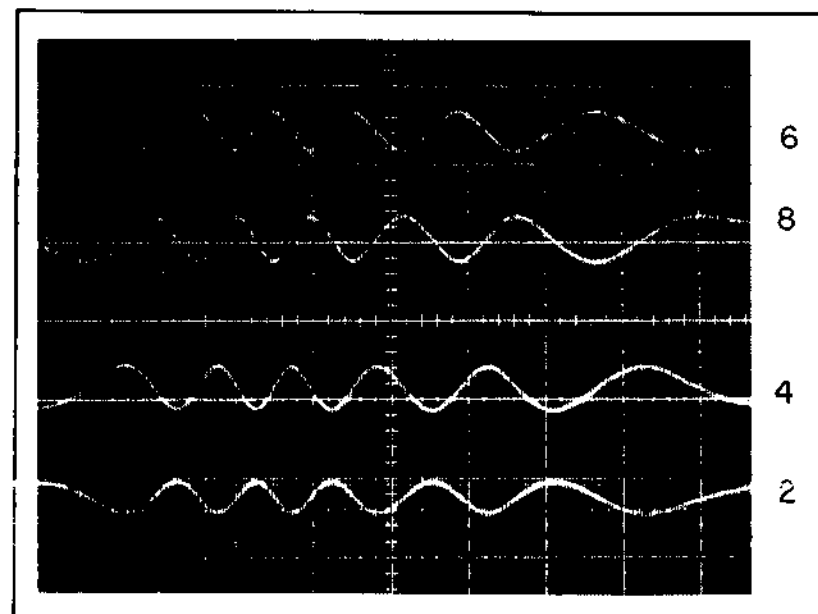

FIGURE 5-39
PRINT WHEEL ARITHMETIC WAVEFORMS

Figure 5-39 shows these four waveforms, taken at their associated test points of TP6 (+A), TP8 (-A), TP4 (+B), and TP2 (-B). These four waveforms are applied to the source connections of four FET's, part of the Reference FET network, to eventually become the "X VELOCITY COMMAND REFERENCE" signal.

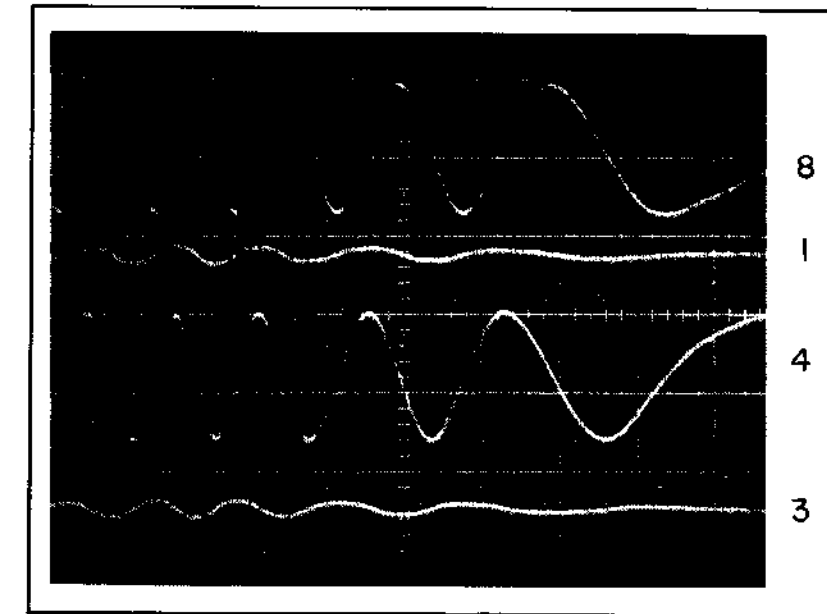

FIGURE 5-40
PRINT WHEEL ARITHMETIC WAVEFORMS

The +A, -A, +B, and -B signals are also coupled, as +A', -A', +B', and -B', to the source connections of a second series of four FET's, a part of the Feedback FET network, to eventually become the "Y FEEDBACK REFERENCE" signal. Coupling is by means of a high pass filter network, where the resultant signals to the FET's are based on the frequency (i.e. motor velocity) of the applied +/-A' or +/-B' signals. Figure 5-40 shows this relationship for the -A/-A' and +B/+B' signals. These waveforms were taken at (top to bottom) TP8, TP1, TP4, and TP3.

- (3) Signals -A, +B, and -B are also applied to a circuit called the "C and D Summing Network", consisting of a pair of schmitt trigger connected operational amplifiers (B113-1/7), and a pair of pulse shaper schmitt triggers in module A159-6/8.

Figure 5-41 shows the waveforms at test points TP7 (top), and TP9 (bottom). The C Summing network generates a HI

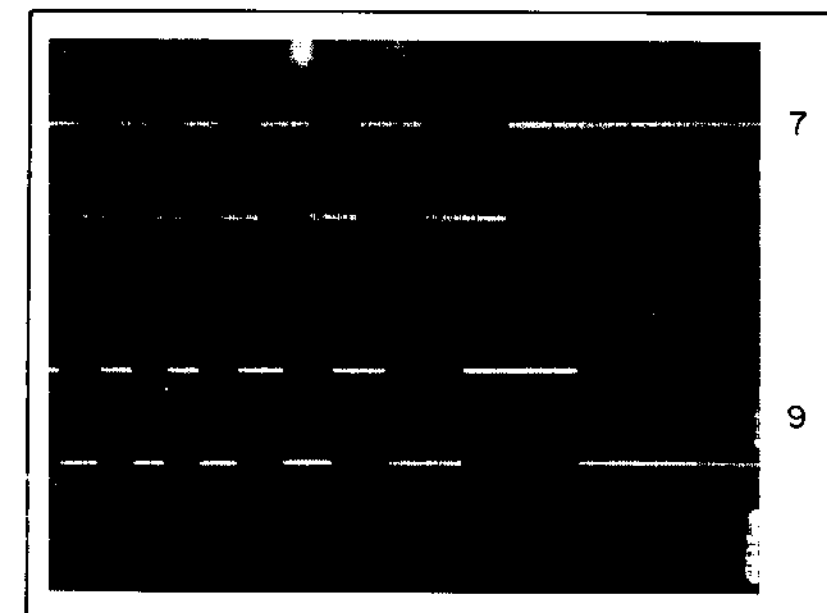
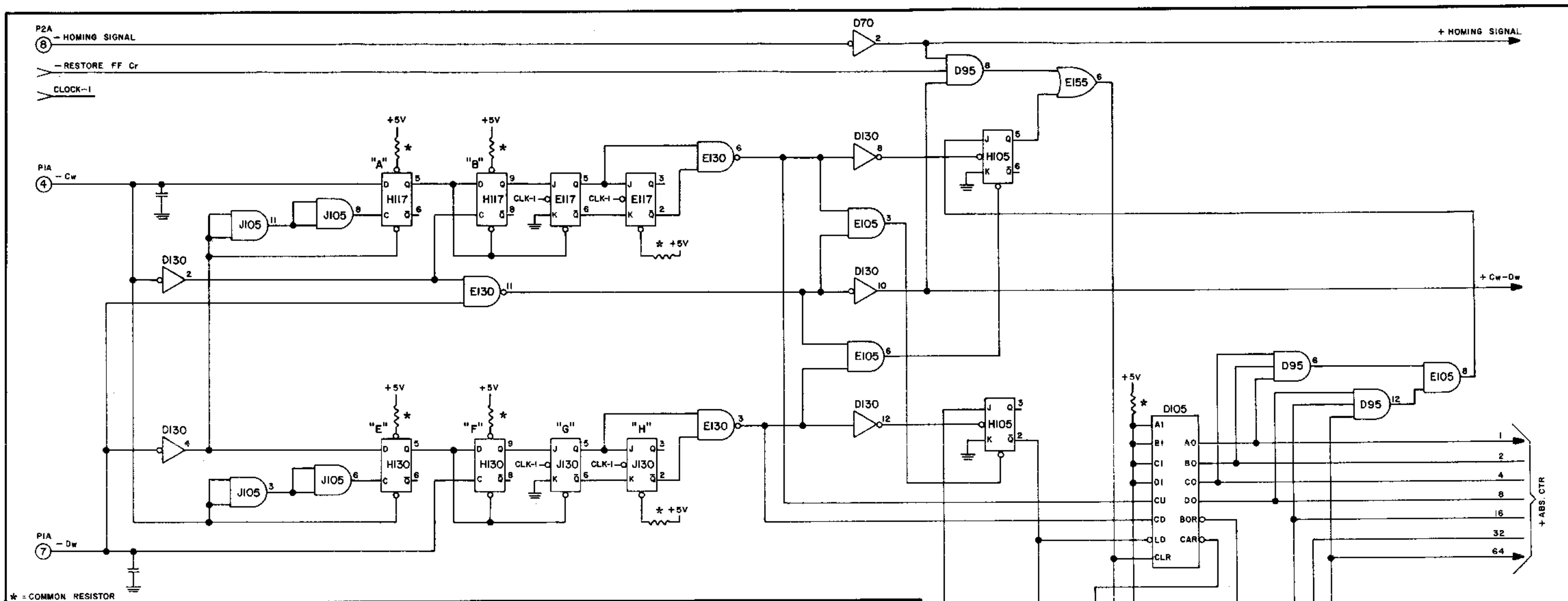

FIGURE 5-41
PRINT WHEEL ARITHMETIC WAVEFORMS



* = COMMON RESISTOR

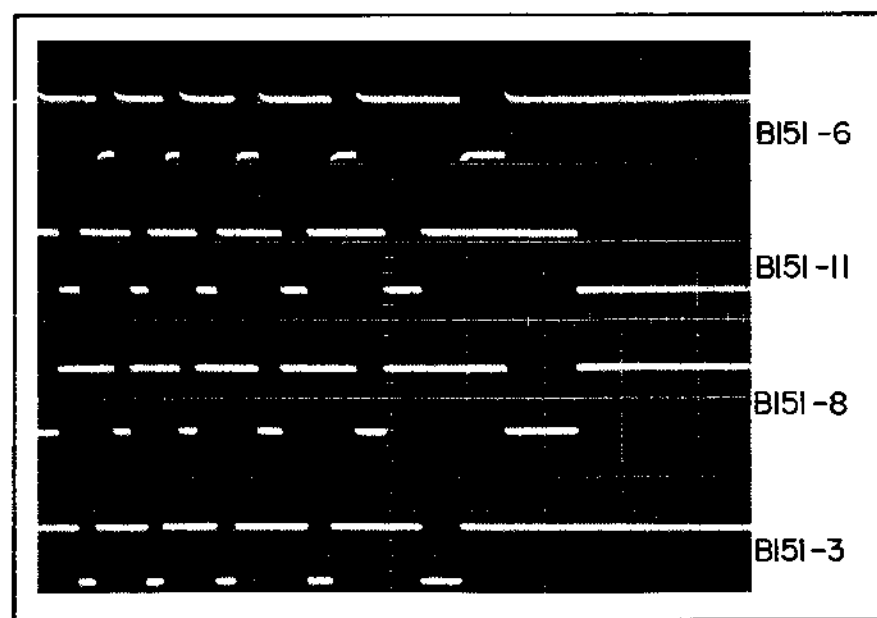

FIGURE 5-42
PRINT WHEEL ARITHMETIC WAVEFORMS

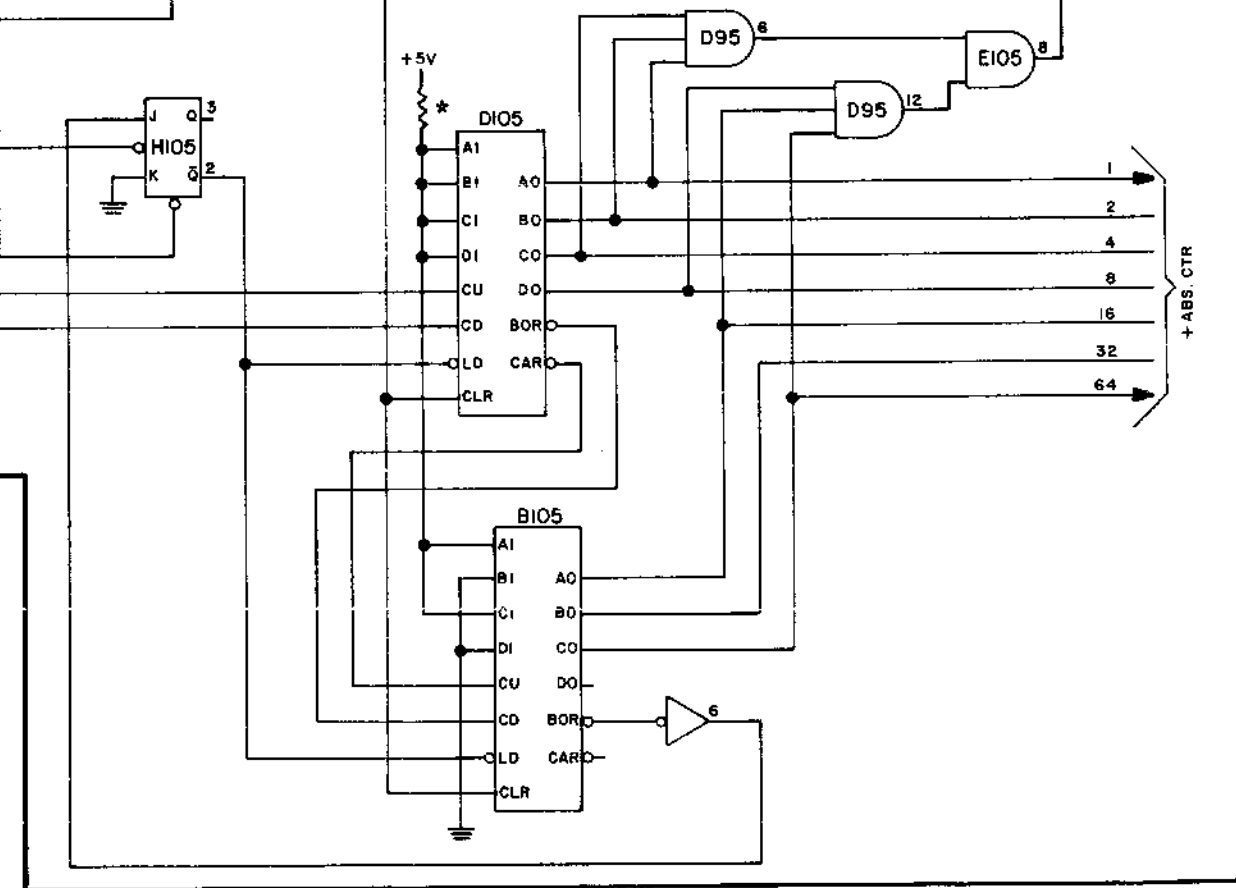

FIGURE 5-34D
CIRCUIT DIAGRAM — PRINT WHEEL ABSOLUTE COUNTER

through A159-6, designated “-C”, whenever the sum of the -A and -B inputs to schmitt trigger B113-1 is greater than 0 volts. The D Summing network generates a HI through A159-8, designated “-D”, whenever the sum of the -A and +B inputs to schmitt trigger B113-7 is greater than 0 volts.

- (4) The -C and -D signals are supplied to the Absolute Counter circuit, as “-Cw” and “-Dw”, where they are used to keep the counter synchronized with print wheel present position. They are also inverted, through A151-4/2, to produce +C and +D. Together, +/-C and +/-D are applied to an AND gate network to produce B159-6 = -C+D,

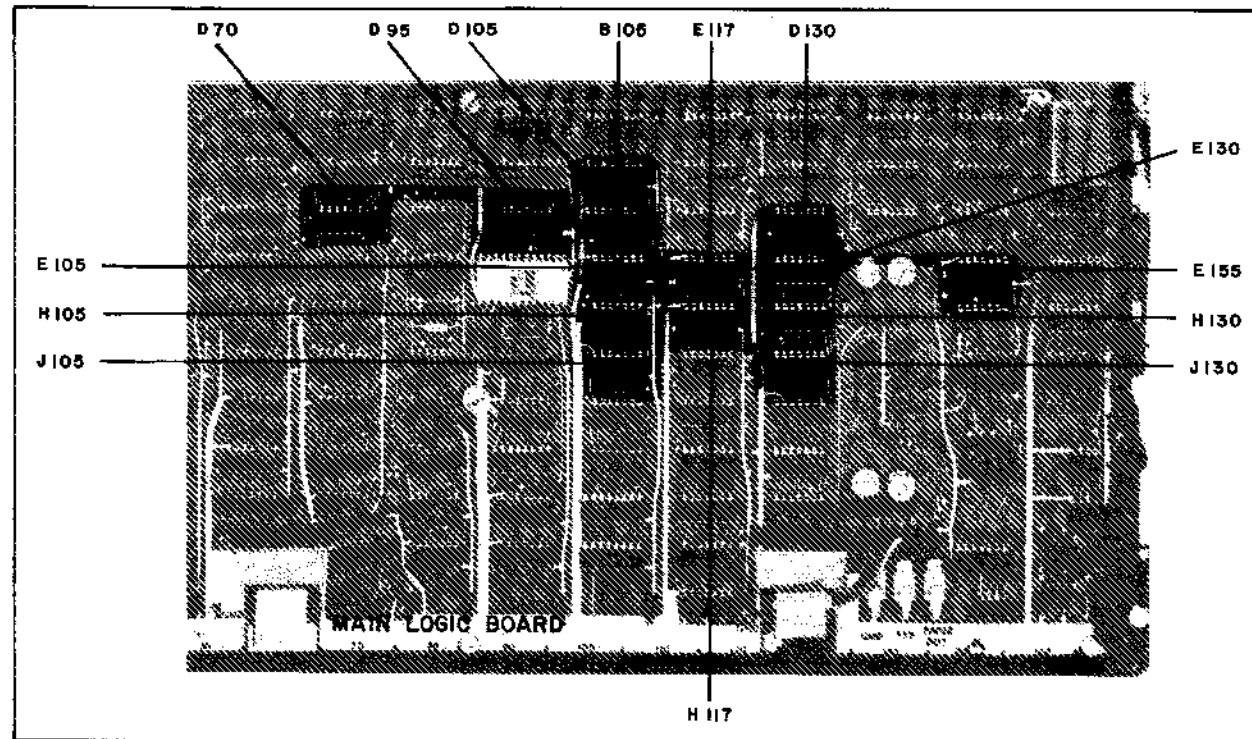

FIGURE 5-35D
COMPONENT LOCATIONS — PRINT WHEEL ABSOLUTE COUNTER

B159-11= $+C-D$, B159-8= $+C+D$, and B159-3= $-C-D$. Beyond these gates, a series of NAND gates then produce B151-6="Phase +A", B151-11="Phase -A", B151-8="Phase +B", and B151-3="Phase -B". These four "Phase" waveforms, shown in Figure 5-42, are applied to the gate connections of the Feedback FET's, to turn them on and multiplex the $+/-A$ and $+/-B$ waveform peaks on to the "Y" line. On the "Y" line, the resultant composite signal is used as feedback at the velocity summing point in the Print Wheel Input/Velocity Control circuit.

- (5) The B159 signals ($-C+D/+C-D/+C+D/-C-D$) are also applied to multiplexer B169. The multiplexer combines these four signals, under control of the +REVERSE signal from the Print Wheel Data Input/Velocity Control circuit, to generate the four signals "Pick +A", "Pick -A", "Pick +B", and "Pick -B". These "Pick" signals (as compared to the "Phase" signals discussed above) are applied to the gate connections of the Reference FET's, to turn them on, and multiplex the positive peaks (to move the print wheel CW), or negative peaks (to move the print wheel CCW) of the $+/-A$ and $+/-B$ waveforms on to the "X" line. On the "X" line, the resultant positive or negative ripple reference level is applied to the velocity control network in the Print Wheel Data Input/Velocity Control circuit, where it becomes Velocity Command Reference Level.
- (6) A status of print wheel movement signal coming into the velocity control network, called -POS TERM, is NAND gated and applied to the strobe input of the multiplexer B169-15, as a print wheel motor detent (or servo hold) signal, and is also applied to NAND gate D155-8. When this signal goes HI, at the end of print wheel movement, it disables the multiplexer, which turns off the Reference FET's, and through NAND gate D155-8 enables just the Reference FET for "-A". With no "Y" feedback voltage, due to the lack of print wheel motor movement and the resultant $+/-A$ and $+/-B$ signals, the -A signal will feed through the motor drive circuit to electrically "lock" the motor in its detent condition.

The Print Wheel Absolute Counter circuit is described in Figure 5-34D. Its major components may be located by referring to Figure 5-35D. Its purpose is to:

- (1) Receive pulse train signals from the Arithmetic circuit, while the print wheel is in motion, and use these to increment or decrement a counter;
- (2) Receive signals from other circuits, and use these to reset its counter to zero during a RESTORE function; and to
- (3) Generate a 7-bit binary output representing the true position of the print wheel, relating to the number of the print wheel "petal" positioned in front of the print hammer.

Operation of the Print Wheel Arithmetic Counter is as follows:

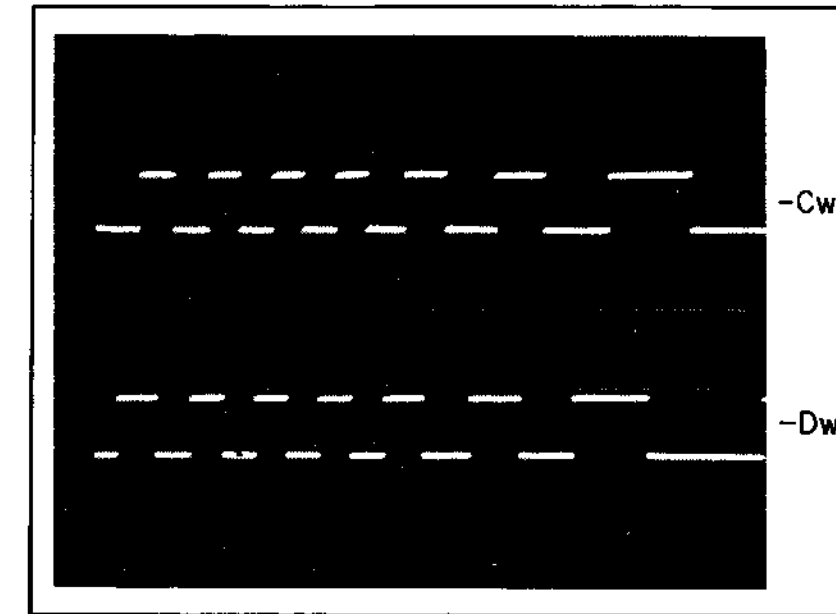

FIGURE 5-43
PRINT WHEEL ARITHMETIC WAVEFORMS

- (1) The Print Wheel Arithmetic circuit supplies a pair of pulse train signals, -Cw and -Dw, as long as the print wheel is in motion. The waveforms shown in Figure 5-43 are actual -Cw -Dw inputs for a movement of seven print wheel positions in the forward direction.

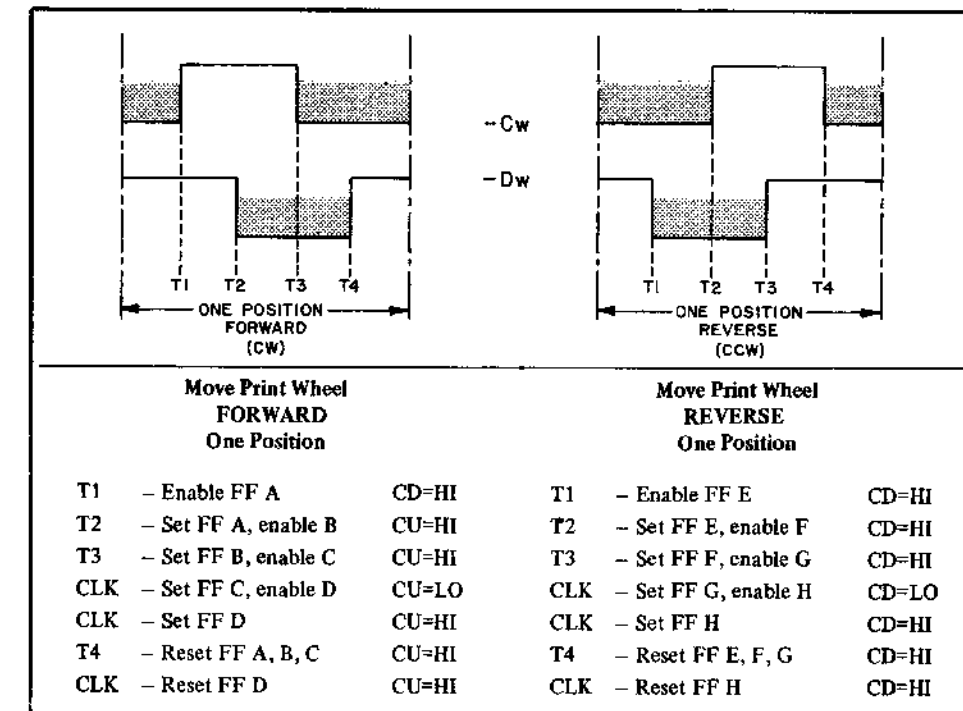

FIGURE 5-44
PRINT WHEEL ARITHMETIC WAVEFORMS

Figure 5-44 illustrates the four time points used by the counter circuit to coordinate its functions.

- (2) Referring to Figure 5-44, the input signal conditions for -Cw and -Dw at time T1 determines whether FF A (H117-5) or FF E (H130-5) will be enabled. The enabled flip-flop then proceeds to activate its flip-flop chain, as shown, while the opposite chain remains inactive.
- (3) Each completed cycle of -Cw and -Dw inputs represents print wheel movement equal to one "petal" position. If

FF A is set first, then NAND gate E130-6 will issue a "count-up" pulse to the counters B/D-105, to *increase* the stored value by 1. If FF E is set first, then NAND gate E130-3 will issue a "count-down" pulse, to *decrease* the stored value by 1. Inverters D130-2/4, and AND gates J105-3/6/8 and 11 form a logic network to provide for enabling and setting the appropriate flip-flop chain. For example, at time T1, $-Dw=HI$ and $-Cw$ goes HI. $-Dw=HI$ through inverter D130-4 places a L0 on the D input of FF E, but $-Cw=HI$ leaves FF E in a preset condition, while enabling FF A. $-Dw=L0$, at time T2 then, passes AND gates J105-11 and -8 to *set* FF A and start a count up sequence. When the $-Dw=L0$ occurs at time T1, the flip-flop chain E/F/G and H will be activated.

- (4) Whenever the stored value in the counter reaches 95 during an up-count sequence, a HI is applied to the J input of JK flip-flop H105-5 and the flip-flop is enabled. The next up-count sets this flip-flop, to apply a HI through OR gate E155-6 to clear the counter and reset it to zero. The counter can then continue to count up from zero as the print wheel passes through its zero position clockwise. Conversely whenever the stored value in the counter reaches 0 during a down-count sequence, a HI is applied to the J input of JK flip-flop H105-3, and that flip-flop is enabled. The next down-count *sets* this flip-flop, applying a L0 to the LOAD inputs to the counter. The counter will load in a value of 95 then, and the counter can continue to count down from 95 as the print wheel passes through its zero position counterclockwise.
- (5) During a RESTORE sequence, AND gate D95-8 is enabled once for each print wheel position passed. When the print wheel reaches its zero position, a $-HOMING\ SIGNAL=L0$ passes through D70-2, D95-8, and E155-6 to clear the counter and reset it to zero. This sequence synchronizes the counter with print wheel position.
- (6) Once synchronized with the print wheel, the content of the B/D105 counters reflects the true, or absolute, position of the print wheel at all times.

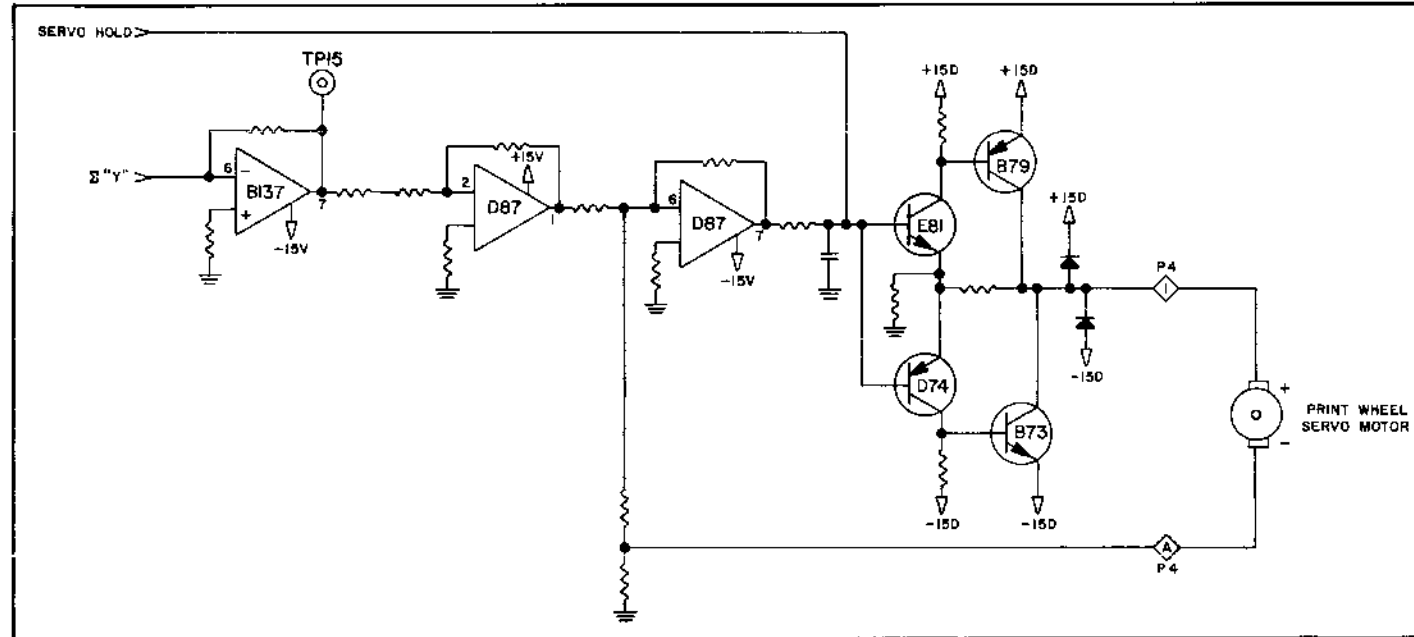

FIGURE 5-34E
CIRCUIT DIAGRAM — PRINT WHEEL MOTOR DRIVE

The Print Wheel Motor Drive circuit is described in Figure 5-34E. Its major components may be located by referring to Figure 5-35E. Its purpose is to:

- (1) Receive the summed $+/-$ "Y" drive signal from the velocity control network, and use this to control drive current to the print wheel servo motor, to drive the print wheel in the right direction at the right velocity to the commanded position, and/or to hold it in a detent position; or
- (2) Receive a Servo Hold=L0 signal from the Power Monitor circuit to disable the motor drive during a CHECK condition.

Operation of the Print Wheel Motor Drive circuit is as follows:

- (1) The sum of "X REFERENCE" and "Y FEEDBACK", the top waveform in Figure 5-45, is applied to amplifier B137-6. The output of this amplifier, as seen at test point TP15 (center waveform in Figure 5-45), is applied to amplifiers D87-2 and D87-6. The output of these amplifiers is applied to the current amplifier circuit on the bases of switching transistors E81 and D74, seen in Figure 5-45 as the bottom waveform. A positive going signal from D87-7

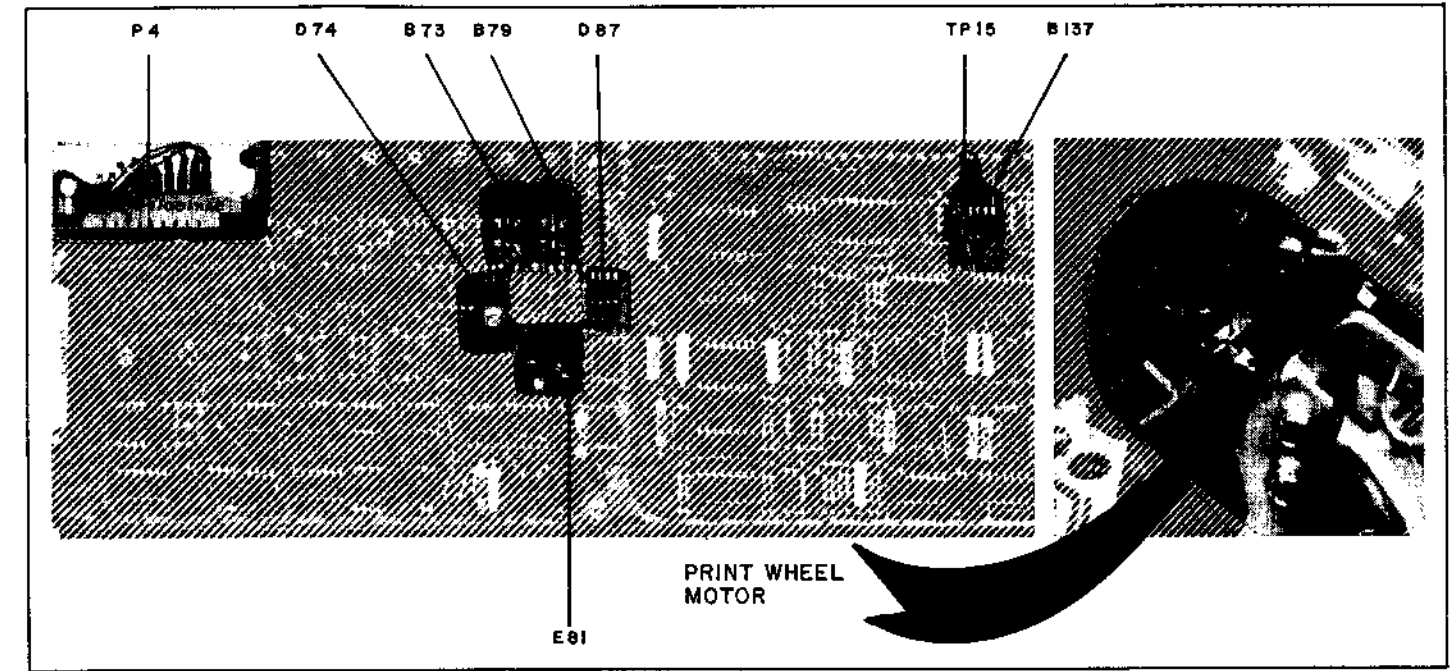

FIGURE 5-35E
MAJOR COMPONENT LOCATIONS — PRINT WHEEL MOTOR DRIVE CIRCUIT

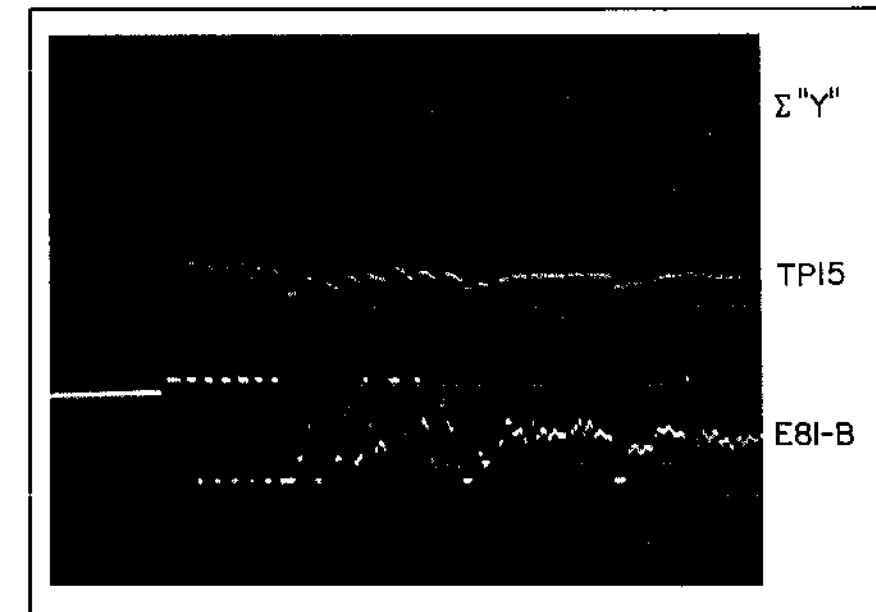

FIGURE 5-45
PRINT WHEEL MOTOR DRIVE WAVEFORMS

will be coupled through transistor E81 to turn on driver transistor B79. A negative going signal will be coupled through transistor D74 to turn on driver transistor B73. These four transistors control the speed and direction of print wheel movement.

The Print Hammer Drive circuit is described in Figure 5-34F. Its components are all located on the Forward circuit board, except for the drive solenoids, which are located on the right hand side of the carriage, just below the right front corner of the Ribbon platform. Its purpose is to:

- (1) Receive a pulse from the Print Wheel Control Logic circuit, and use this pulse to energize the print hammer solenoid; and
- (2) Inhibit print hammer action whenever power to the printer has been interrupted, and reapplied.

Operation of the Print Hammer Driver circuit is as follows:

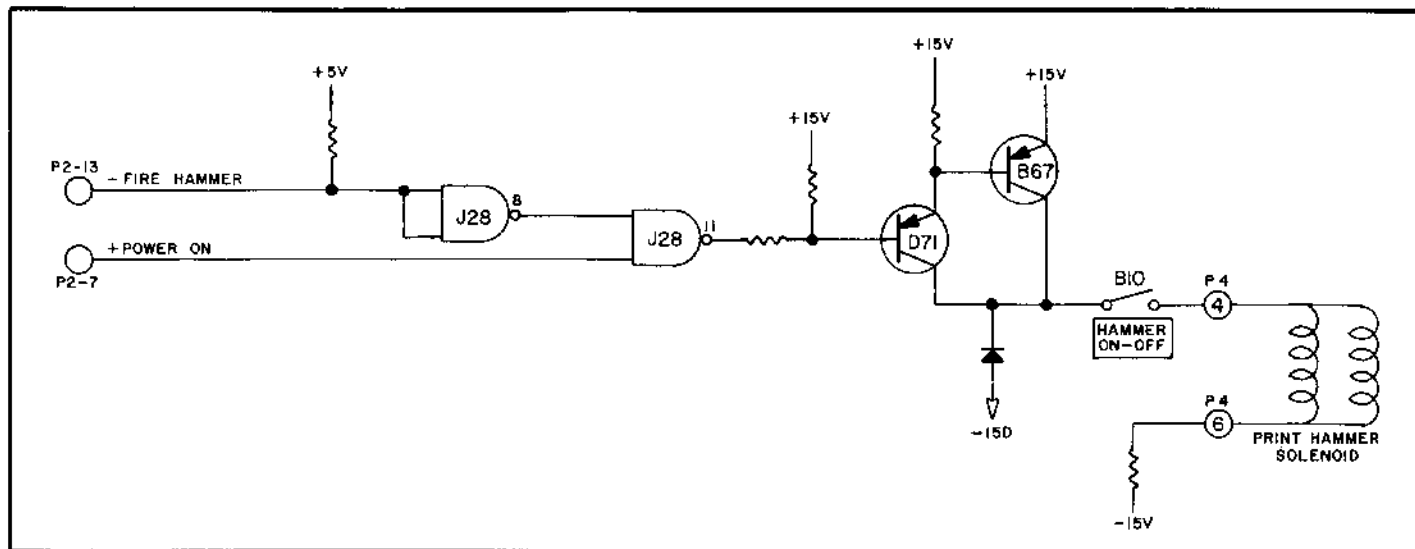

FIGURE 5-34F
CIRCUIT DIAGRAM — PRINT HAMMER DRIVE CIRCUIT

- (1) Whenever power has been applied to the printer, and has reached proper levels, the +POWER ON=HI signal enables NAND gate J28-11.
- (2) With gate J28-11 enabled, a -FIRE HAMMER=L0 signal, from the control circuit, will pass NAND gates J28-8 and -11, and be applied as a L0 to the base of switching transistor D71.
- (3) Transistor D71 will turn on, and turn on power transistor B67, to energize the print hammer solenoid. The amount of energy transferred to the print hammer by the solenoid is controlled by the length of time the solenoid is energized.

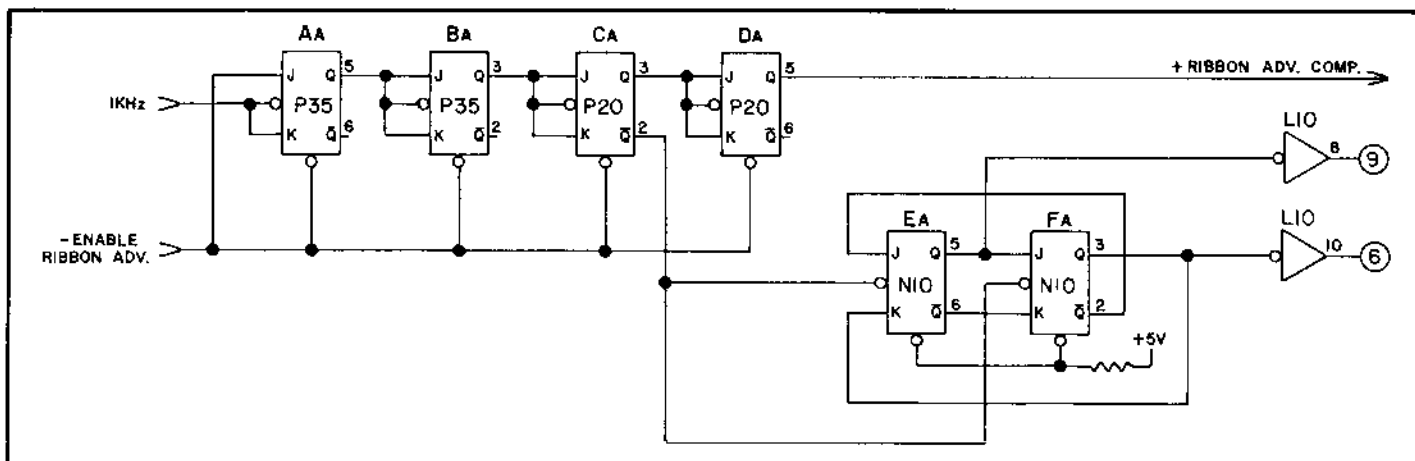

FIGURE 5-34G
CIRCUIT DIAGRAM — RIBBON ADVANCE LOGIC

The Ribbon Advance Logic circuit is described in Figure 5-34G. Its major components may be located by referring to Figure 5-35F. Its purpose is to:

- (1) Receive an enabling pulse from the Print Wheel Control Logic circuit, and a clock signal; and
- (2) Generate a pair of signals to be used in the Ribbon Advance Motor Drive circuit to control the drive motor.

Operation of the Ribbon Advance Logic circuit is as follows:

- (1) Ribbon Advance flip-flop Aa is clocked by negative going 1 KHz clock pulses. When the -ENABLE RIBBON ADVANCE input goes L0, the flip-flops Aa, Ba, Ca, and Da, are reset. At the end of -ENABLE RIBBON ADVANCE=L0, FF Aa-J goes HI and Aa-Q carries the 1KHz signal. FF's Ba and Ca both divide by 2, resulting in a FF Ca-Q output composed of two negative going pulses for each -ENABLE RIBBON ADVANCE=L0.
- (2) FF Ca's Q output is used to clock phasing flip-flop's Ea and Fa. Both of these flip-flops are held in the reset state, with FF Fa-Q=HI connected to FF Ea's J input. The first negative pulse from FF Ca-Q sets FF Ea. This produces a ØC RIBBON ADVANCE=L0 output, and enables FF Fa. The second negative pulse from FF Ca-Q then sets FF

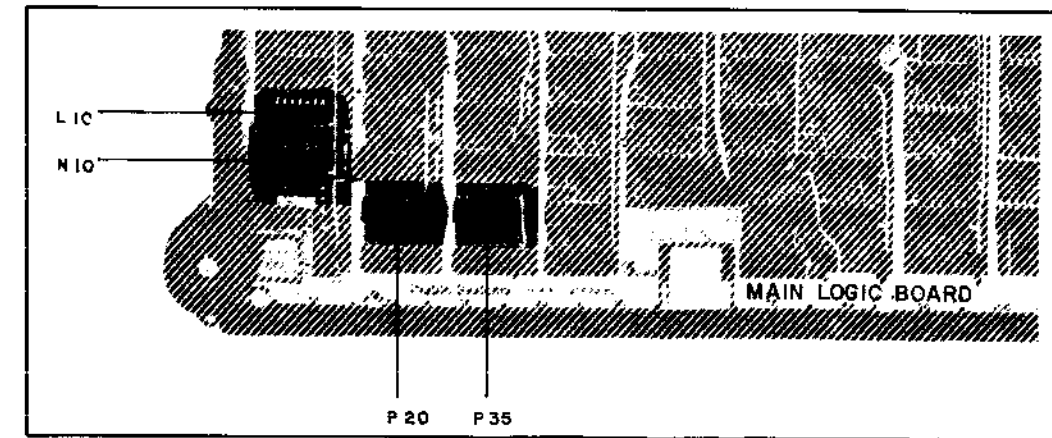

FIGURE 5-35F
MAJOR COMPONENT LOCATIONS — RIBBON ADVANCE LOGIC CIRCUIT

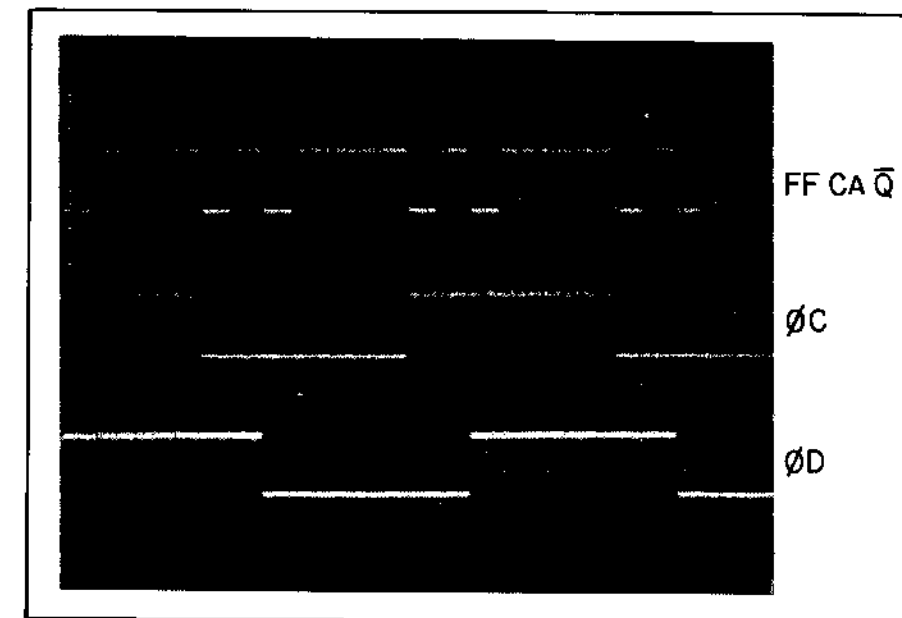

FIGURE 5-46
RIBBON ADVANCE WAVEFORMS

Fa, to produce a ØD RIBBON ADVANCE=L0 output, and place a L0 on FF Ea-J. Figure 5-46 shows the ØC and ØD squarewaves compared to the FF Ca-Q output. Both FF's Ea and Fa will remain in this state until the next ribbon advance command is received.

The Ribbon Advance Motor Drive circuit is described in Figure 5-34H. Its major components may be located by referring to Figure 5-35G. Its purpose is to receive a change of state on both ØC and ØD inputs, and advance the drive stepper motor one step per pair of ØC/ØD changes.

Operation of the Ribbon Advance Motor Drive Circuit is as follows:

- (1) The ØC input is applied through inverters J51-2/4 to two dual NAND drivers H56 and H63 in parallel. When ØC=L0, 1Y=HI and 2Y=L0. Conversely, when ØC=HI, 1Y=L0 and 2Y=HI. When the condition 1Y=HI/2Y=L0 exists, transistor B61 turns on, and current flows from 2Y=L0, through diode E53, P4-C, and the motor's "C" winding, and back through the transistor to +15VD. The motor will advance one halfstep. When ØD=L0 later, then transistor B49 turns on, and the motor's "D" winding will be energized, causing the motor to move the second half-step to complete the ribbon advance movement cycle.
- (2) Since ØC always changes state before ØD, the drive motor will always step in the same direction.

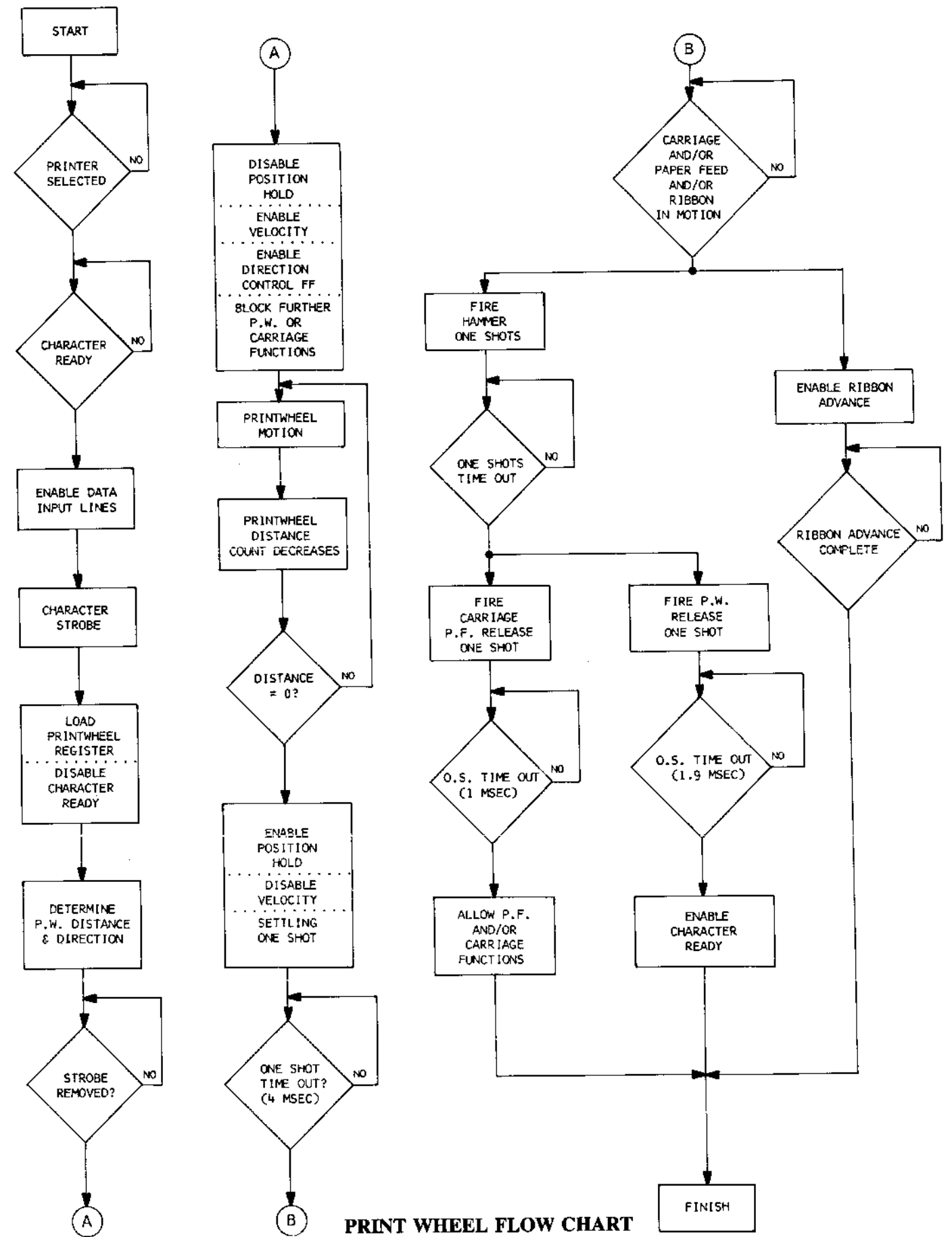
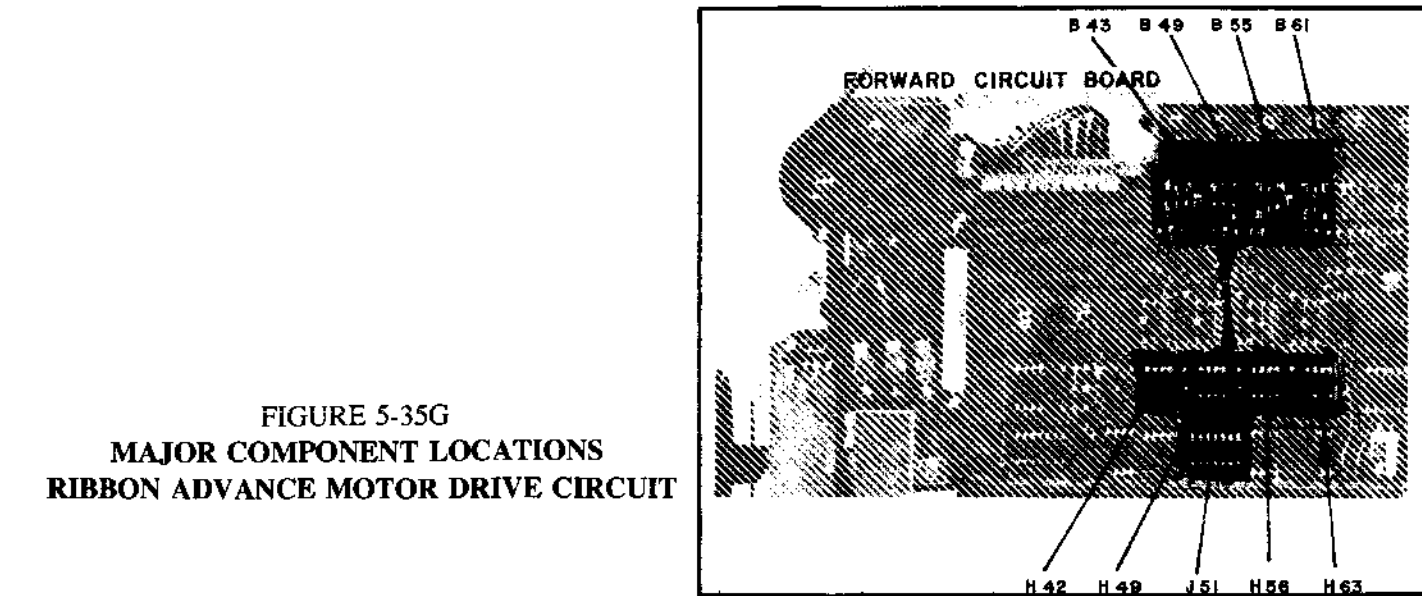
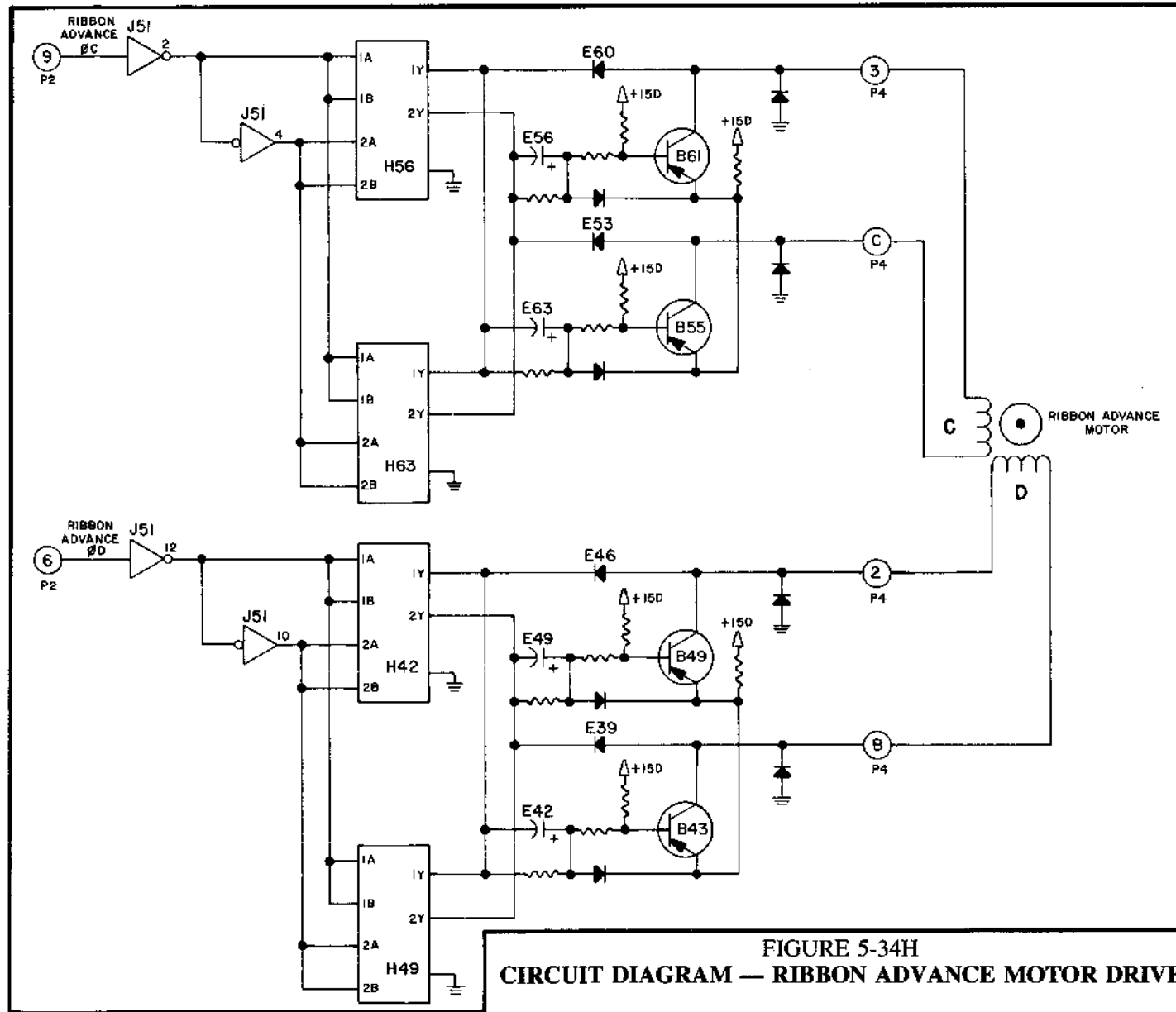

The Print Wheel Operation is summarized in the flow chart.

5.10 MISCELLANEOUS CIRCUITS

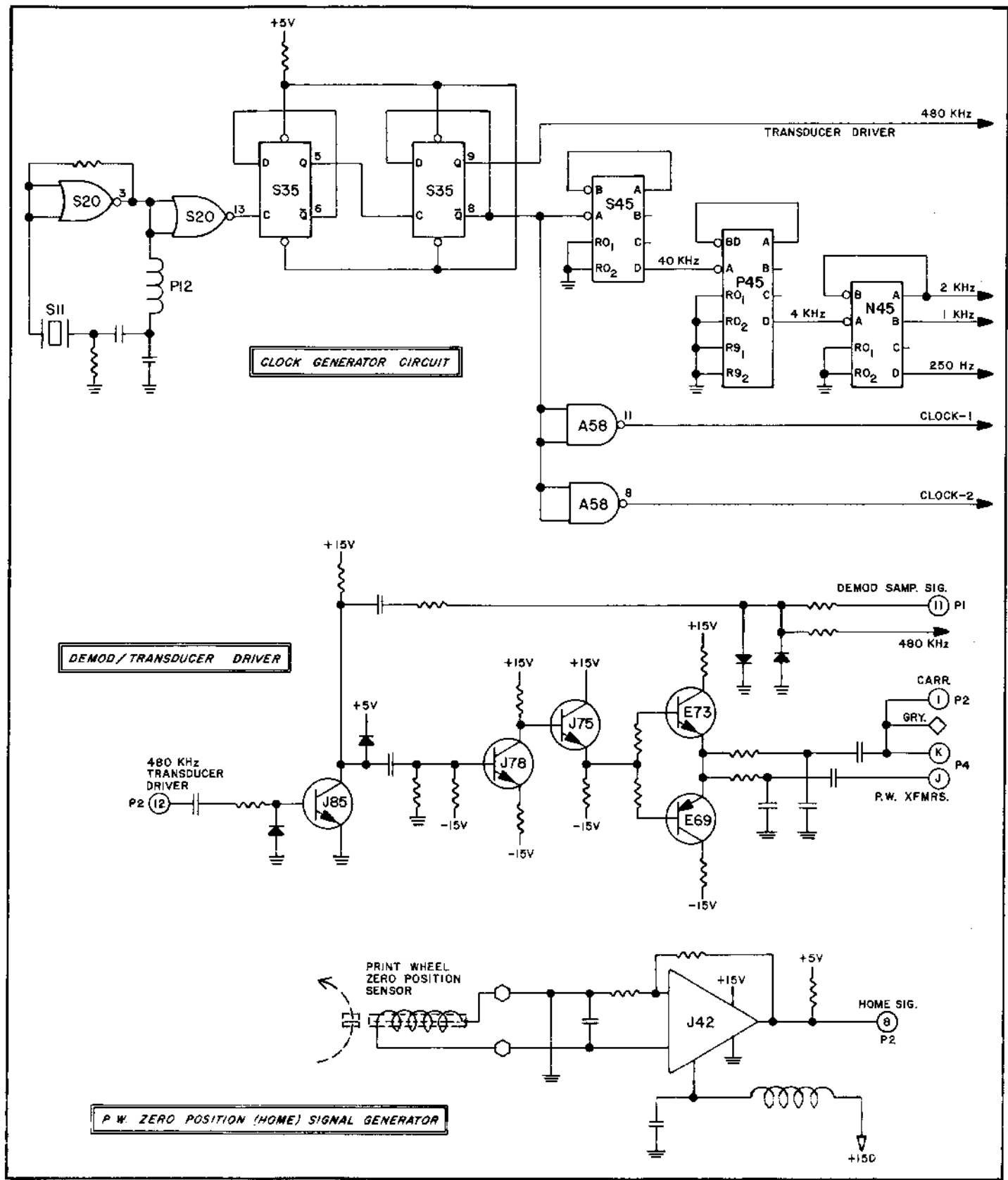

FIGURE 5-34I
MISCELLANEOUS CIRCUITS

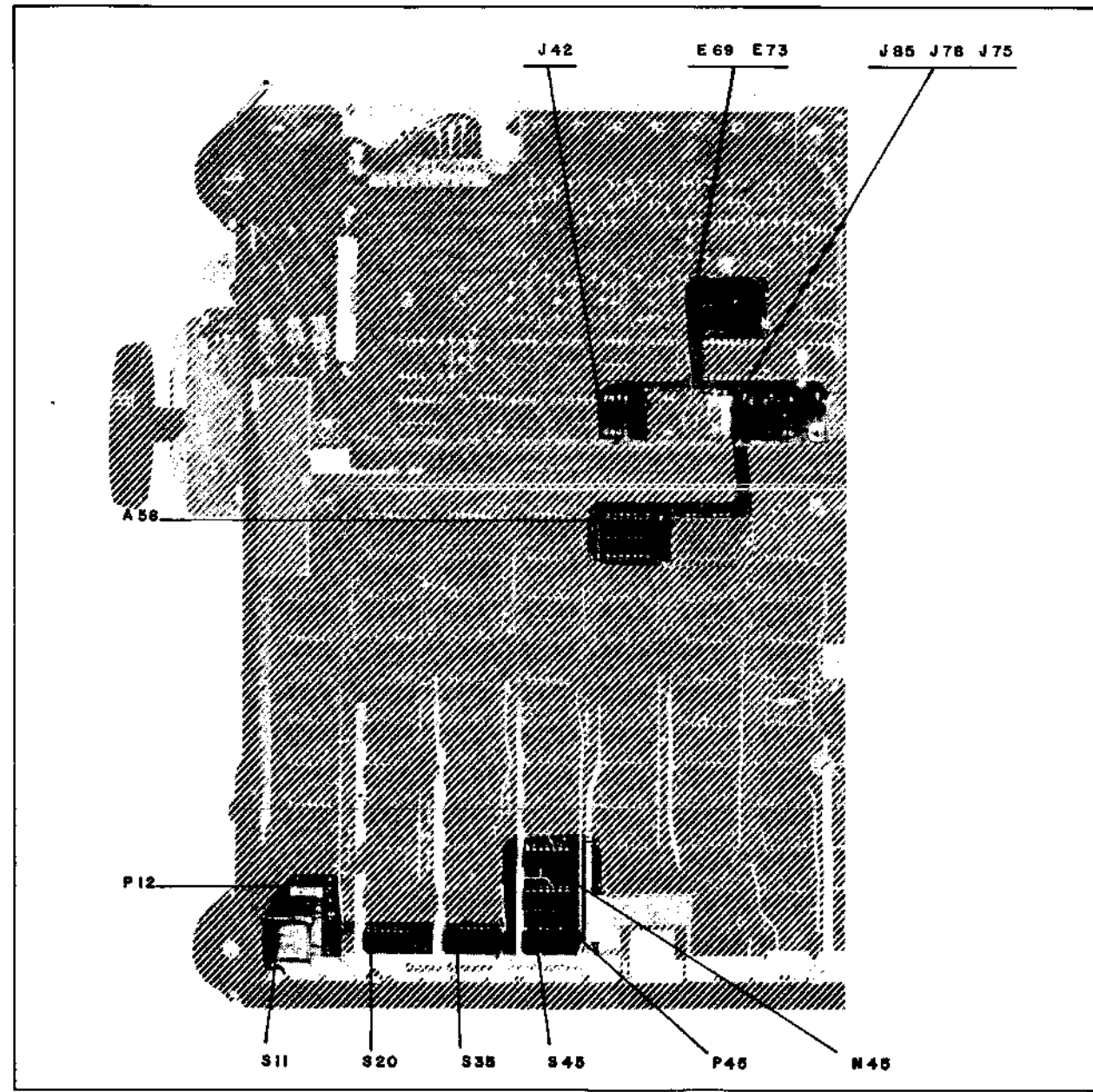

FIGURE 5-35H
MAJOR COMPONENT LOCATIONS — MISCELLANEOUS CIRCUITS

These circuits include the Clock Generator, the Demod/Transducer Driver, and the Print Wheel Homing Signal Generator.

5.10.1 Clock Generator

The Clock Generator's purpose is to generate the several timing signals needed throughout the printer's circuits.

Operation of the Clock Generator is as follows:

- (1) The basic signal is generated by a crystal controlled oscillator, consisting of crystal S11, NOR gate S20-3, inductor P12, and a resistor-capacitor network.
- (2) The 1.92MHz square wave oscillator output, at buffer NOR gate S20-13, is connected to a divided-by-4 stage, consisting of two dc flip-flops S35-5 and -9.
- (3) The 480KHz square wave output at S35-9 (Q), is supplied to the carriage and print wheel circuits as a transducer drive signal. The inverted 480KHz output at S35-8 (Q) is inverted again in NAND gates A58-11 and -8, and supplied to printer circuits as CLOCK-1 and CLOCK-2.

- (4) The S35-Q output is also connected to a driver chain as follows. The 480KHz input is first connected to S45, a divide-by-2/divide-by-6 counter, whose D output is then 40KHz. This signal is next connected to P45, a decade or divide-by-10 counter, whose D output is then 4KHz. This signal is then connected to N45, a 4-bit binary counter module connected as a ripple through counter. This module performs simultaneous division by 2, 4, 8, and 16 at the A, B, C, and D outputs respectively. The A output (N45-12) is a 2KHz signal supplied to the paper feed data input circuit. The B output (N45-9) is a 1KHz signal supplied to the ribbon advance logic circuit. The C output is not used. The D output (N45-11) is a 250KHz signal supplied to ribbon lift, restore, and check circuits.

5.10.2 Demod/Transducer Driver

The Demod/Transducer Driver's purpose is to amplify the 480KHz input, and provide regulated and filtered outputs.

Operation of the Demod/Transducer Driver is as follows:

- (1) Transistor J85 buffers and simplifies the 480KHz input. Its inverted output becomes the Demod Sampling Signal, and is also used as an input for the transducer drivers.
- (2) J78 and J75 shape and amplify the output of transistor J85, and this is used to drive the push-push amplifiers E73/E69. The regulated non-inverted output is supplied to the carriage and print wheel transducers as a drive signal.

5.10.3 Print Wheel Zero Position Signal Generator

The Print Wheel Zero Position (Home) Signal Generator's purpose is to generate a pulse each time the print wheel reaches the zero (or home) position.

Operation of the circuit is as follows:

- (1) A piece of iron is fastened to the transducer's rotary member. A sensing coil, with an iron core, is positioned on the transducer frame so that it will be aligned with the iron slug on the rotary member when the print wheel zero position "petal" is aligned with the print hammer.
- (2) When the slug becomes aligned with the sensor's iron core, the magnetic field is altered, generating a pulse in the sensor coil's circuit.
- (3) The pulse is amplified and shaped by amplifier J42, and is supplied to the print wheel circuits as -HOMING SIGNAL=L0.

5.11 PRINTER CIRCUIT INTERRELATION SUMMARY

5.11.1 Ready Lines

Each separate major function within the printer circuit provides an output, called READY. When L0, the circuit "Ready" output signals that the function named is ready to receive commands. When HI, this output signals that the function is busy. Made available outside the printer as status indicators, these signals perform an enabling function to control the issuing of commands by the controller.

5.11.2 Interlock Lines

As noted earlier, paper feed and carriage movements can be carried on simultaneously, because either can move without regard for the other. The character printing operation, however, mechanically bridges all three functions during the time a character is being printed. That is, the print hammer contacts a print wheel "petal," which in turn contacts ribbon, to paper, and to the platen. All functions, except the print hammer action, must therefore be at rest while the hammer is in motion. The paper feed and carriage movement circuits exchange interlock signals with the print wheel circuit. Either paper feed or carriage movements will inhibit hammer fire action, while print wheel/hammer fire action will inhibit the other two.

5.11.3 Restore Function

The RESTORE sequence produces reinitialization of the printer, by returning the carriage to the first character position, rotating the print wheel to a starting position, and resetting the internal logic circuits. The RESTORE sequence is introduced to the logic when power is turned on or when the user activates the Restore Command input line.

The RESTORE operation is shown in Figure 5-47 (flow chart), Figure 5-48 (timing chart), and defined in the sequence Initiate, Carriage Movement, and Print Wheel Movement.

5.11.3.1 Initiate

- (1) When the RESTORE command is issued, or the power is turned on, the Restore function is initiated by force *resetting* the Check flip-flop and the Restore flip-flops Ar, Br, and Cr. When FF's Ar and Br are *reset*, a RESET I signal is issued to *reset* Restore FF Dr, Carriage FF's Bc and Ac, Print Wheel FF's Bw and Aw, Ribbon Lift control FF's Hr and Ir, and Paper Feed FF's Bp and Ap.
- (2) When the carriage FF Bc is *reset*, to force *reset* FF's Cc and Dc, and the Restore FF Dr is *reset*, a carriage logic reset

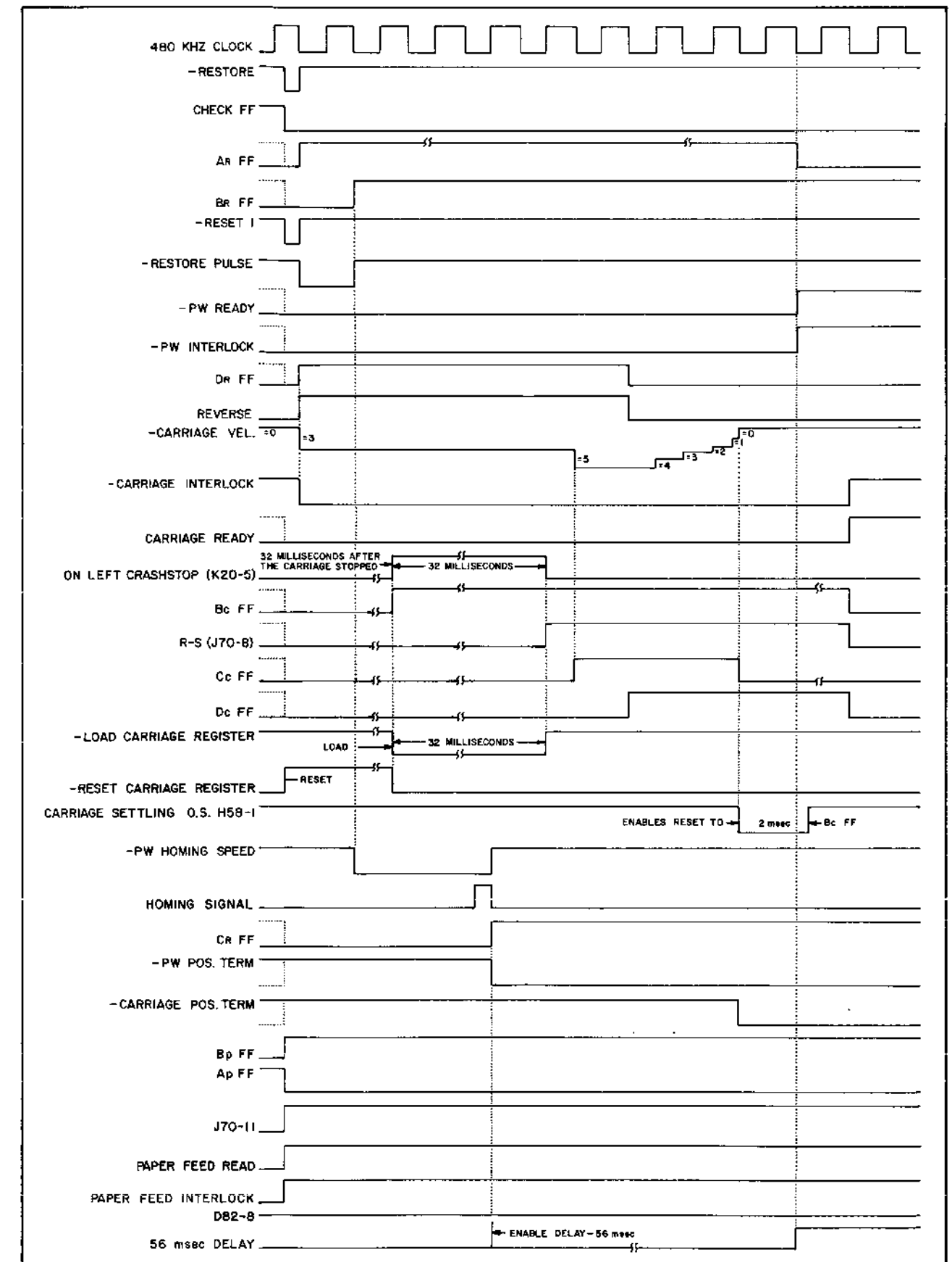

FIGURE 5-48
RESTORE TIMING CHART

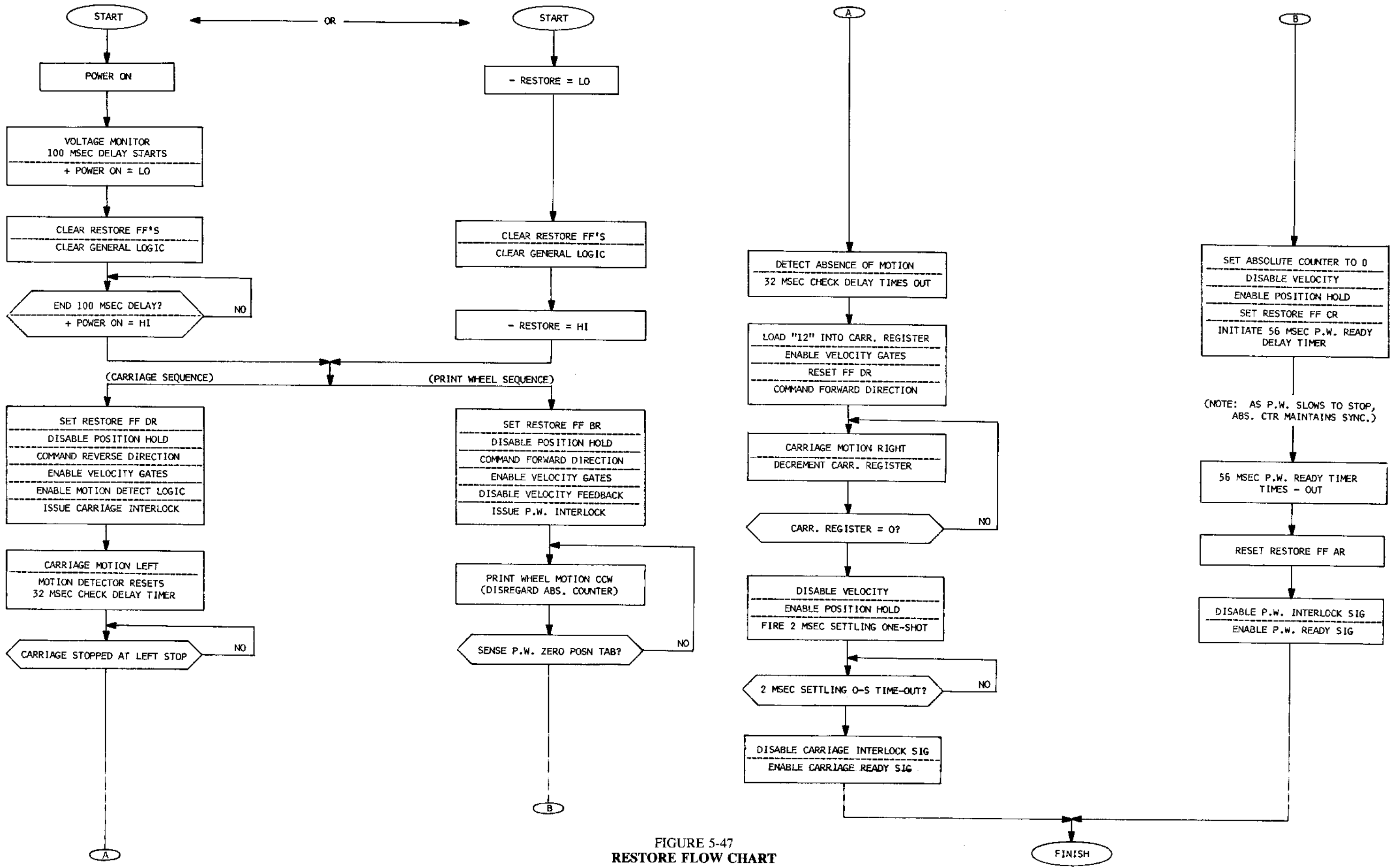

FIGURE 5-47
RESTORE FLOW CHART

mode is established where; the Carriage Interlock signal is enabled, the Carriage Speed control signals are inhibited, the Carriage Position (POS TERM) signal is inhibited, and the Carriage Ready signal is inhibited.

- (3) When the Print Wheel FF Bw is *reset*, Print Wheel FF's Cw, Dw, and Ew are *reset*, FF Fw is clocked to the reset state by the next 480KHz CLOCK-2 signal, and Restore flip-flop control of the Print Wheel Interlock and Print Wheel Ready signals is enabled. The reset state of Restore FF's Ar and Cr issues a Print Wheel Interlock signal, and inhibits the Print Wheel Ready status.
- (4) When the Paper Feed FF Bp is *reset*, Paper Feed FF's Cp, Dp, and J70-11 (R-S) are forced *reset*, and -PAPER FEED READY=HI is generated. The reset state of FF Cp inhibits the paper feed clock, and steps the Paper Feed θA and θB signals one increment if a paper move is in progress, or stores the current state of θA and θB signal if a paper move is not in progress. This allows the paper to be either advanced one increment and electronically positioned, or positioned in place.
- (5) The reset state of the Restore FF Cr inhibits a 56msec delay network on the K input of FF Ar.

5.11.3.2 Carriage Movement

- (1) When FF Ar is *set*, the RESET 1 signal is inhibited and a Restore Pulse is issued. The RESTORE PULSE force *sets* FF Dr to: establish the reverse drive to the carriage; issue a carriage velocity-3 signal to move the carriage to the left mechanical stop; apply a value of 12 to the Carriage Input Data Register; enable the carriage motion detector (K20-5); and issue the CARRIAGE INTERLOCK signal to inhibit the Print Hammer while the carriage is being moved and -CARRIAGE READY=HI. (The number "12" is significant in that it specifies a right shift of 1/5", or 12 increments of 1/60" to position 0, that the carriage will undergo after indexing to the left mechanical stop.
- (2) When the carriage has been stopped on the left mechanical stop for 32 msec, the value of 12 is loaded into the carriage register and FF Bc is forced *set*. The set state of FF Bc enables the R-S FF J70-8 to be *set* when FF K20-5 is *reset* — 64 msec after the carriage stopped against the left mechanical stop. The set state of the R-S FF enables FF Cc to be *set* by the next CLOCK-1 signal.
- (3) When FF Cc is *set*, FF Dc is enabled to *set* and FF Dr is enabled to *reset* on the next CLOCK-1 pulse, and the velocity gates are enabled. The value of 12 in the carriage register, the reset state of the direction bit, and the set state of FF Cc combine to issue a forward-carriage velocity-5 command to the carriage drive, and initiates a 12-increment right carriage move from the left mechanical stop.
- (4) When the carriage is positioned, FF's Cc, Dc, and Bc are returned to the *reset* state, the Carriage Interlock signal is inhibited, and the -CARRIAGE READY=L0 signal is issued.

5.11.3.3 Print Wheel Movement

- (1) The next CLOCK-2 pulse after FF Ar is *set* also *sets* FF Br to: inhibit the RESTORE PULSE; enable the ribbon control circuits; and issue the Print Wheel Homing Speed signal. The print wheel is rotated until the transducer detects the zero position indicator (home mark), and issues a Homing signal to *set* FF Cr. The *set* state of FF Cr inhibits the Print Wheel Homing Speed signal, enables the Print Wheel Absolute counter, and issues a Print Wheel POS TERM signal. The Absolute Counter is used to keep track of the print wheel position. The Print Wheel POS TERM signal is applied to the Print Wheel Motor Drive circuit to stop the print wheel.
- (2) The *set* state of FF Cr also starts a 56 msec delay network, and enables the first clock signal after the delay to *reset* FF Ar. When FF Ar is *reset*, -PW INTERLOCK=HI, and -PRINT WHEEL READY=L0.

5.12 PRINTER MECHANICAL SYSTEMS

The HyType I Printer's mechanical systems consist of: the Platen System; the Carriage System; and the Print System.

- (1) The Platen System includes the platen with ratchet release, the platen hold-down latches, the platen pressure rollers and release system, and the drive system.
- (2) The Carriage System includes the carriage support and guide system, left and right mechanical stops, and the carriage drive system.
- (3) The Print System includes the ribbon lift mechanism, ribbon drive, and the print hammer assembly.

The various systems may be described as follows:

5.12.1 The Platen System

- (1) The Platen Drive Ratchet Release operates to disengage the Platen Shaft from its drive gear when the right hand knob is pressed in.
- (2) The two platen release latches enable removing the Platen Assembly from the printer frame. The Platen Release Tabs on each end are pressed down simultaneously and the Platen lifted out.

- (3) The Platen Pressure and Release system operates to move the paper feed pressure rollers away from the Platen through a camming and scissors action when the Platen Pressure Release Lever is pulled forward.

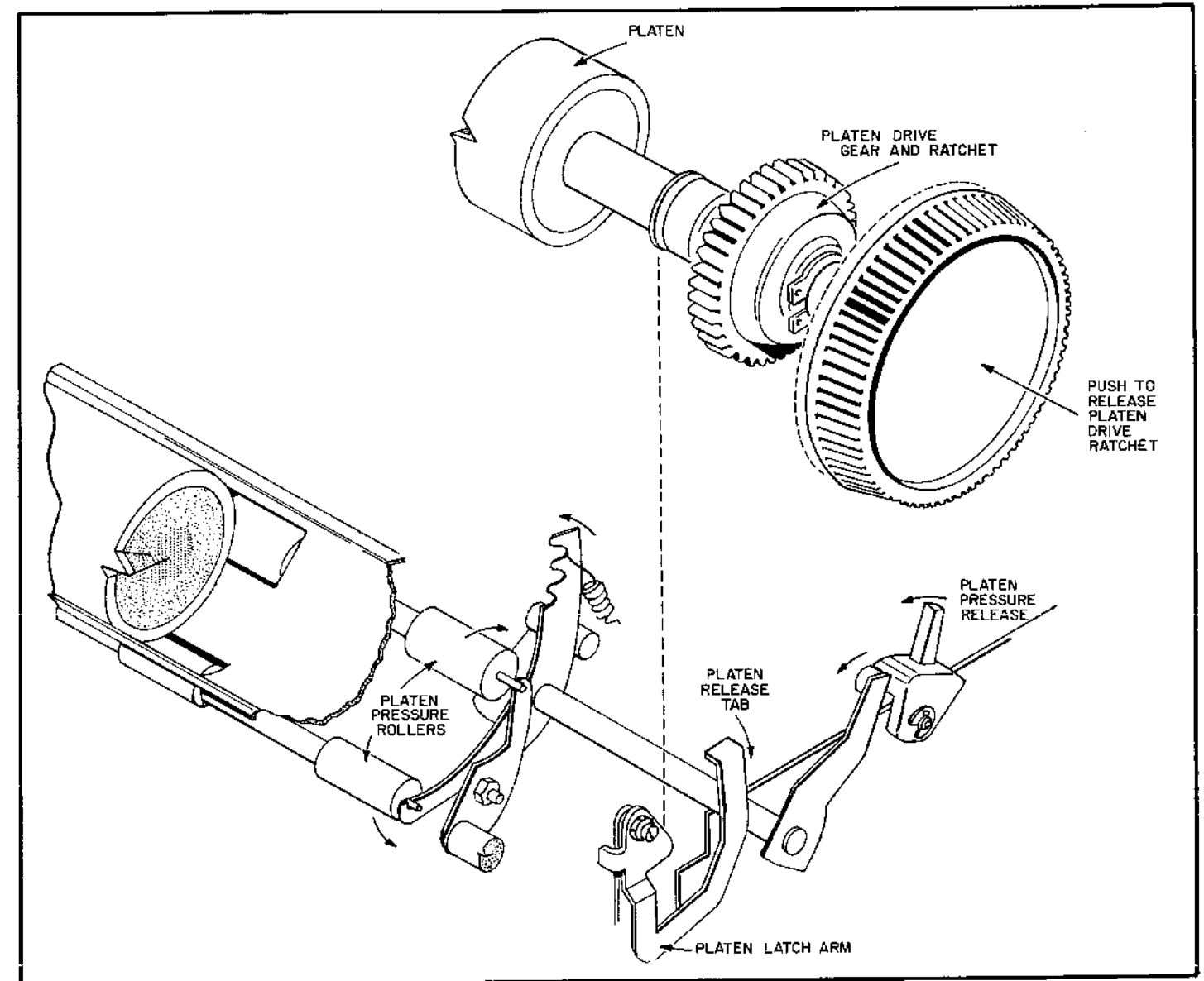

FIGURE 5-49
PLATEN MECHANICAL OPERATING SYSTEM

5.12.2 The Carriage System

Figures 5-50A and 5-50B illustrate the Carriage mechanical system.

- (1) The Carriage Support and Guide Assembly operates to move the print system components smoothly and accurately along the length of the print line. It consists of two rigid round rods (or rails), and the carriage structure itself. The two rails extend laterally the length of the printer. The carriage rides along these rails on a 3-point suspension system. A close inspection of the printer will show the wheel arrangement and the clamp arrangement used to both support and guide the carriage.
- (2) The Carriage Mechanical Stop System consists of a "C" shaped metal piece mounted on a pivot on each of the printer's side frames, with a heavy spring connecting their lower arms. Due to a malfunction, program error, or erroneous data input, the carriage will, from time to time, overrun its normal travel limits and come to rest against one of these stops. Pivoting and spring loading the top arms helps prevent damage to the carriage in the event of a high speed overrun. Adjustment screws on each end allow for adjusting the stops.

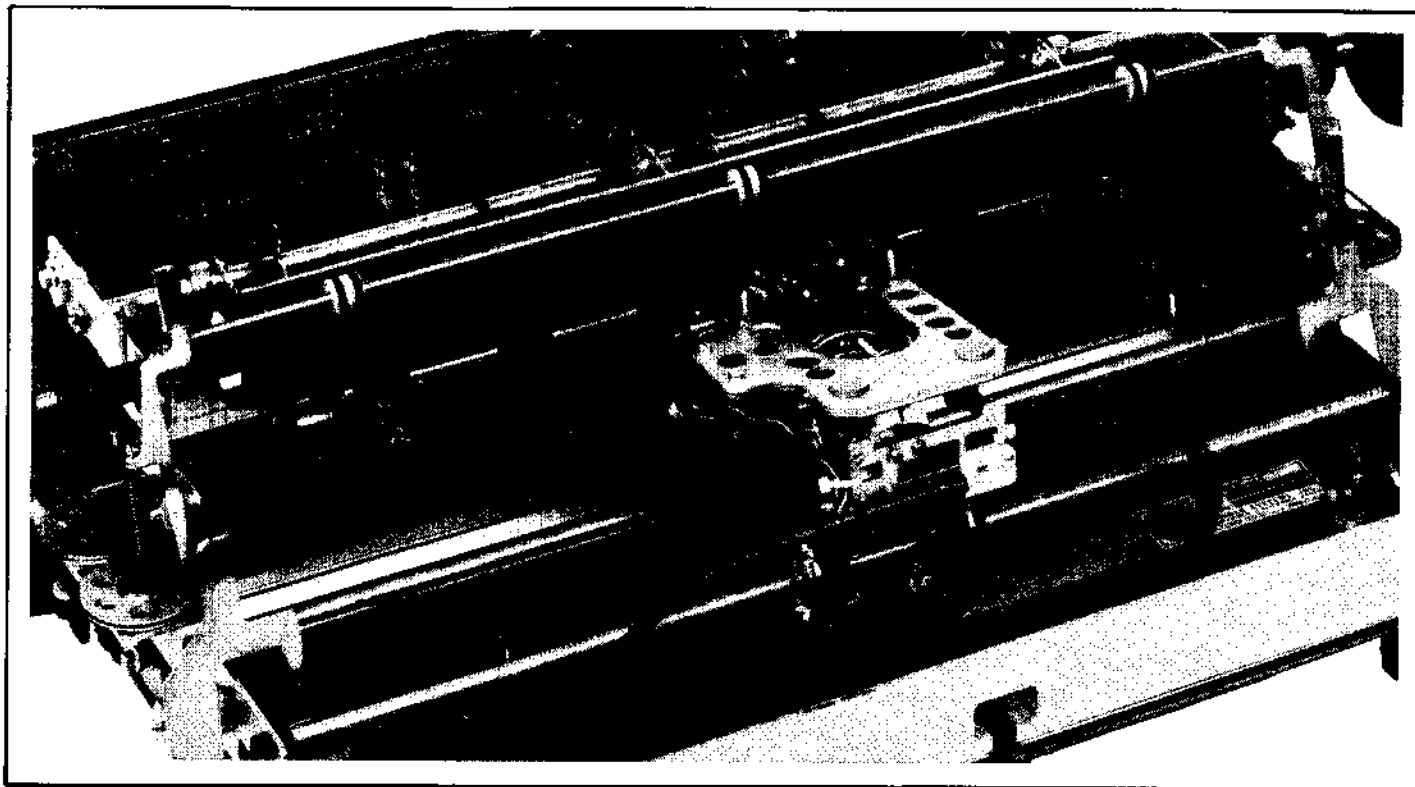

FIGURE 5-50A
HYTYPE I PRINTER

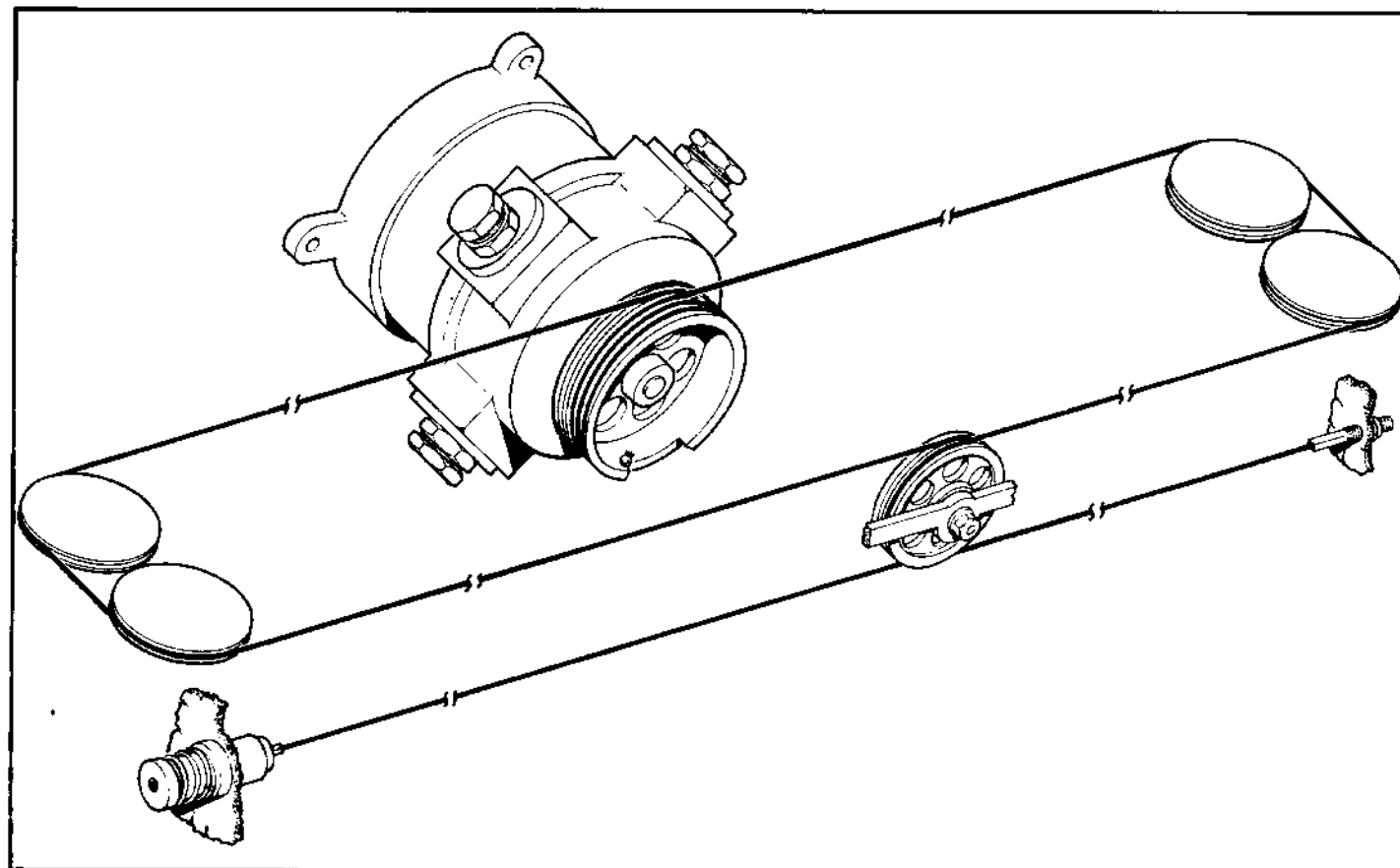

FIGURE 5-50B
HYTYPE I PRINTER — CARRIAGE MOTOR DRIVE AND CABLE SYSTEM

- (3) The Carriage Drive Motor and Cable System, seen partially in Figure 5-50A, is more fully illustrated in Figure 5-50B. Rotation of the motor takes up cable from one side while letting it out on the other, on a 1:1 ratio. The cables then pass outside the printer frame on each side around a pulley system, and back inside to the carriage. The cables then pass over opposite sides of a dual pulley fastened to the carriage, and back to tensioning devices on the side frames. The carriage pulley results in a 2:1 ratio of motor to carriage movement.

5.12.3 The Print System

- (1) The Ribbon Lift System consists of a hinged platform mounted on top of the Carriage Assembly. This platform is fitted with a spring clamp to hold ribbon cartridges in place, the Ribbon Advance Drive Motor and Gear Train, and is mounted on a hinge pin near its forward end. A solenoid under the forward end pulls this end of the platform down, and "lifts" the ribbon exposed behind the print wheel.
- (2) The Print Hammer Assembly is mounted over the top of the Print Wheel Motor. It consists of the Print Hammer and Check-Ball inside a sleeve, mounted so the end of the hammer will strike the end of the print wheel petals, a hammer actuating lever with adjustment and stop bumpers, and a drive solenoid. The solenoid pulls the actuating lever back, where its far end strikes the hammer, driving the hammer toward the platen to strike the print wheel petals.

SECTION 6 MAINTENANCE

6.1 GENERAL MAINTENANCE INFORMATION

The limited number of moving parts within the HyType I Printer simplifies trouble shooting, and minimizes maintenance and repair time.

Replacement of the unit, to shorten system down time in the event of a malfunction, is made practical by the printer's light weight and low cost.

When unit replacement is impractical, sub-assembly replacement is a ready alternative. The sub-assemblies recommended as part of a normal spares inventory are listed in paragraph 6.2. These are directly interchangeable, requiring no more than a minor mechanical readjustment or two if the carriage assembly were to be replaced. Extensive component replacement or mechanical adjustments are normally attempted only in a service depot or factory environment.

6.1.1 Maintenance Requirements

The reduced reliance on mechanical devices reduces normal preventive maintenance to surface cleaning and lubrication, and a minor adjustment or two by the operator, as outlined in the Preventive Maintenance instructions in Section 6.4. Higher level maintenance procedures are included from Section 6.5 on.

6.1.2 Maintenance Instructions

The HyType I user should study sub-section 6.2 below, compare that information with his existing or intended facilities and capabilities, and determine the maintenance level he intends to maintain. Spares provisioning and test equipment assignment may then be accomplished economically.

The user should also familiarize himself with all the information in this section prior to performing any maintenance or adjustment.

6.1.3 Maintenance Precautions

Avoid damage to the HyType I Printer. Observe the following precautions during service and maintenance activity:

- (1) Never make or break connections to the printer while power is turned on.
- (2) Applying power to the printer initiates a RESTORE sequence, which includes movement of the carriage. Make sure the carriage is free to move LEFT *before* applying power.
- (3) Do not operate the printer with the carriage tilted forward (away from the platen). In this situation, the print hammer could travel far enough into its support tube to expose the hammer guide ball. The ball will usually become dislodged and be lost when this happens. Make sure the Hammer Disable Switch is OFF before attempting operation in this situation.
- (4) Do not use alcohol to clean the Platen, or the Paper Feed Pressure Rollers. Alcohol hardens rubber, resulting eventually in paper feed problems. Use "Fedron Platen Cleaner," or its equivalent, to clean these items.

"CAUTION: 'Fedron Platen Cleaner' is flammable, and has a low flash point!"

- (5) Do not use platen cleaner to clean the clear plastic card guide. Platen cleaners are usually harmful to plastics, and may damage the card guide. Clean the card guide with alcohol.
- (6) The print wheel does not need cleaning under normal operating conditions. Slight ink build-up is normal, especially with a new ribbon. Such ink deposits are partially returned to the ribbon as its ink content diminishes in use. Only unusually severe operating conditions will make print wheel cleaning necessary. When needed, clean the print wheel with alcohol.

6.2 MAINTENANCE LEVELS, TOOLS, EQUIPMENT, AND SPARES

6.2.1 Levels of Maintenance

This paragraph describes the tools, equipment, and spares required for each of the three levels of service and maintenance. Preventive maintenance is simple, and easily accomplished by the user. Corrective maintenance capability varies greatly from user to user. Consequently, the maintenance procedures described herein are divided into three categories, or levels each requiring successively more extensive equipment, spares, and technical capability. The levels of maintenance are:

- (1) **Level 1** — Ribbon Cartridge and Print Wheel change. Surface cleaning and lubrication. Print intensity adjustment.
- (2) **Level 2** — Level 1 items, plus the following: Unit replacement. Exchange of printed circuit boards (PCB's). Minor assembly exchange, such as platens, platen knobs, and paper feed pressure rollers. Minor adjustments, including paper feed pressure rollers, paper feed gear backlash, ribbon lift, card guide replacement and adjustment, ribbon

guide adjustment, and hammer adjustments.

- (3) **Level 3** — Levels 1 and 2 items, plus major disassembly and reassembly, alignment, trouble diagnosis and component replacement. This level is recommended for depots only.

6.2.2 Preventive Maintenance Items — Level 1

The following listed items should be available to persons operating and/or servicing the printer on a regular basis:

- (1) Fedron Platen Cleaner, or equivalent.
- (2) #70243 Oil, Shell Turbo 27, or equiv. (2 drops/appl.)
- (3) #70363 Light Oil (1 drop/appl.)
- (4) #70364 Polyoil (light white grease)
- (5) #70658 Molykote 557 (aerosol lubricant)
- (6) #99000-01 Alcohol Pads (91% Isopropyl alcohol or equiv.)
- (7) Lint free wipers
- (8) Clean, low pressure compressed air (optional, see NOTE, Section 6.4.2.4)

CAUTION:

1. Observe all safety rules for use of compressed air, including use of safety goggles.
2. Do not use alcohol on rubber items.
3. Do not use platen cleaners on plastic items.
4. 'Fedron Platen Cleaner' is flammable, and has a low flash point.

6.2.3 Corrective Maintenance Items — Levels 2 and 3

The following listed items should be available to persons involved in corrective maintenance and/or repair of a Model 1200 HyType I Printer:

6.2.3.1 Level 2 — Level 1 maintenance items, plus:

- (1) One set of PC Boards
#21020 Main Logic board
#21006 Forward Logic board
#20673 Combo PCB/Heat Sink Assembly
- (2) #20565 Platen Assembly, with
#22490 Tractor Feed Assembly as required, or
#22470 Pin Feed Platen Assembly
- (3) #70189 Loctite
- (4) #22647 Hammer Adjustment Fixture*
- (5) #31100 Holding Cap**
- (6) Two Potentiometers; 0-10K Ohm, and 0-100K Ohm
- (7) Hand tool assortment, adequate for electronic/electro-mechanical repair, and including a T-handle spring hook.
- (8) #20582 Shipping Container, complete

* = 9° Hammer only. Use fixture #20997 for other hammer installation.

** = Usable with all print hammer styles.

6.2.3.2 Level 3 — Levels 1 & 2 maintenance items, plus:

- (1) #20100 Carriage Assembly
- (2) #20595 Carriage Drive Motor Assembly
- (3) #20459 Paper Feed Drive Motor Assembly
- (4) #20993 Mechanical End Stop Adjustment Fixture
- (5) #20994 Print Wheel Adjustment Fixture
- (6) #20399 Print Wheel Hub Fixture
- (7) #20996 Height Adjustment Fixtures (2)
- (8) Tensiometer, Electromatic Equip't Co. Model "DXX-1KD" or equivalent, calibrated for Diablo #20598 Cable.
- (9) Oscilloscope, vbw 15MHz, vds 100mV/cm, sw sp 50ns/cm

(10) #20900 Model 500 Programmable Tester*

* = The Model 500 Tester is used to exercise/test the various functions of the HyType I Printer, and other Diablo peripheral products.

6.3 LOCATION OF ASSEMBLIES

Figures 6-1, 6-2, 6-3, and 6-4 show the name and location of the major printer assemblies and components.

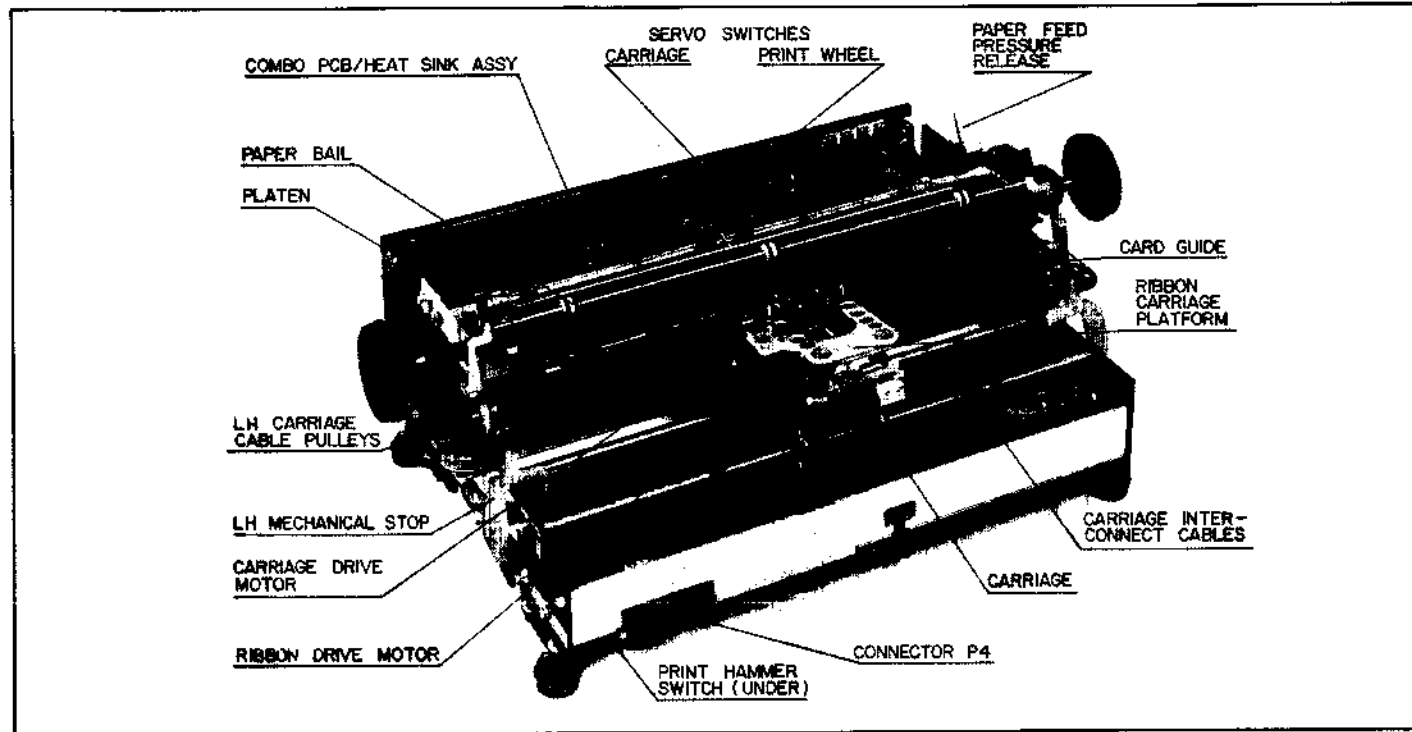

FIGURE 6-1

HYTYPE I PRINTER — MAJOR COMPONENT LOCATIONS — FRONT VIEW

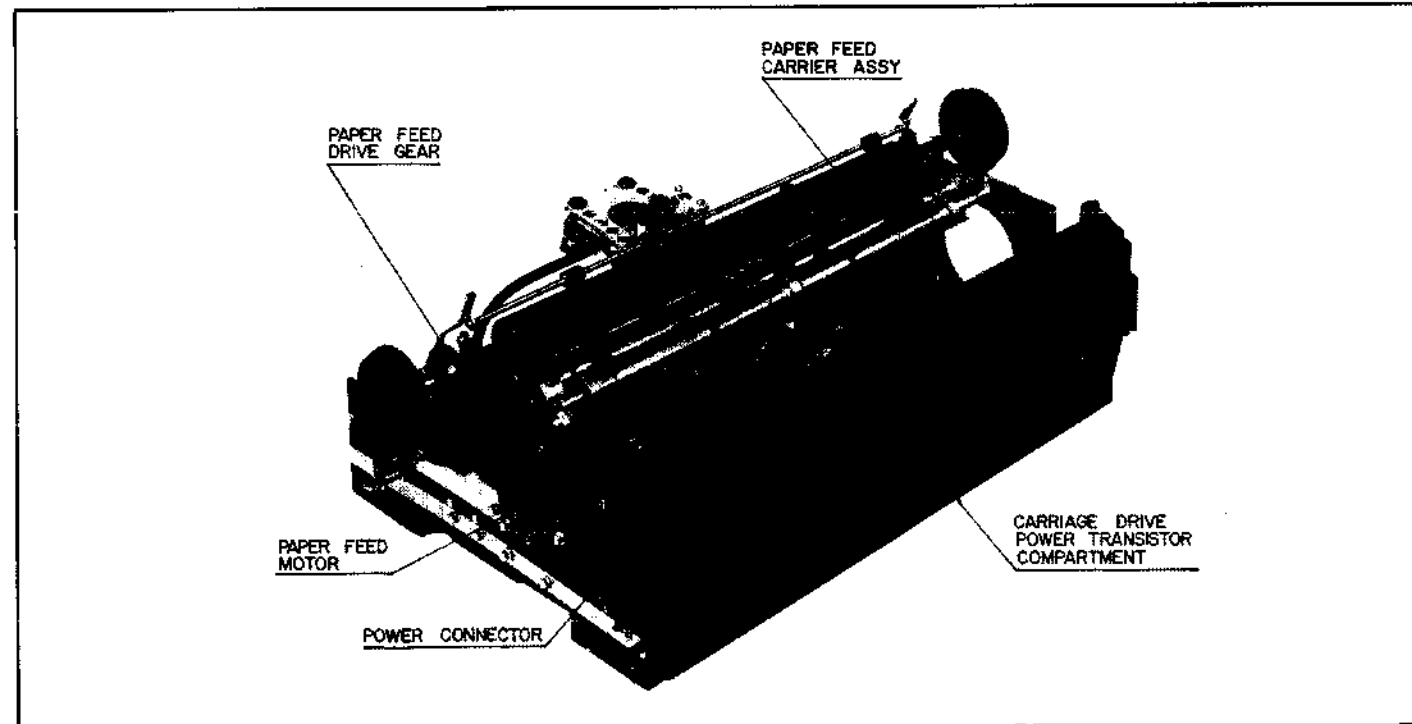

FIGURE 6-2

HYTYPE I PRINTER — MAJOR COMPONENT LOCATIONS — REAR VIEW

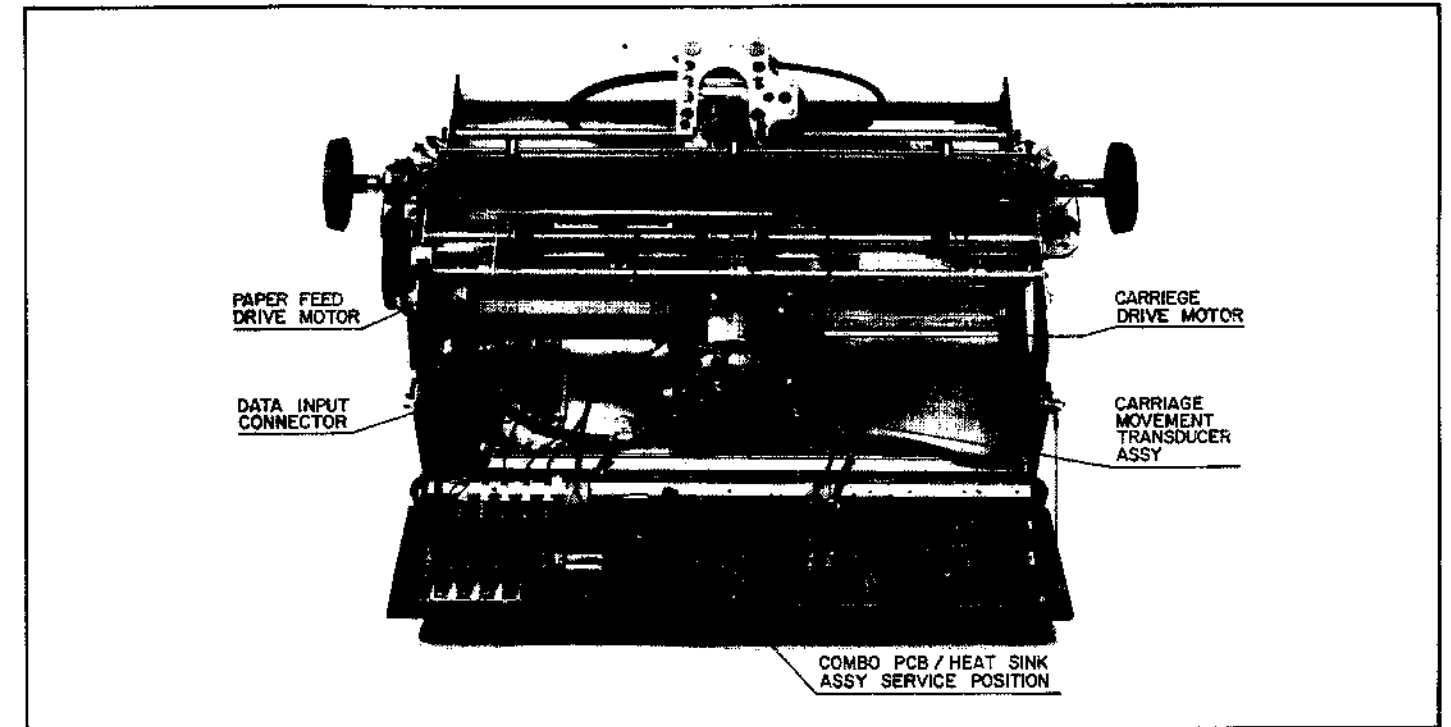

FIGURE 6-3

HYTYPE I PRINTER — MAJOR COMPONENT LOCATIONS — REAR VIEW OPEN

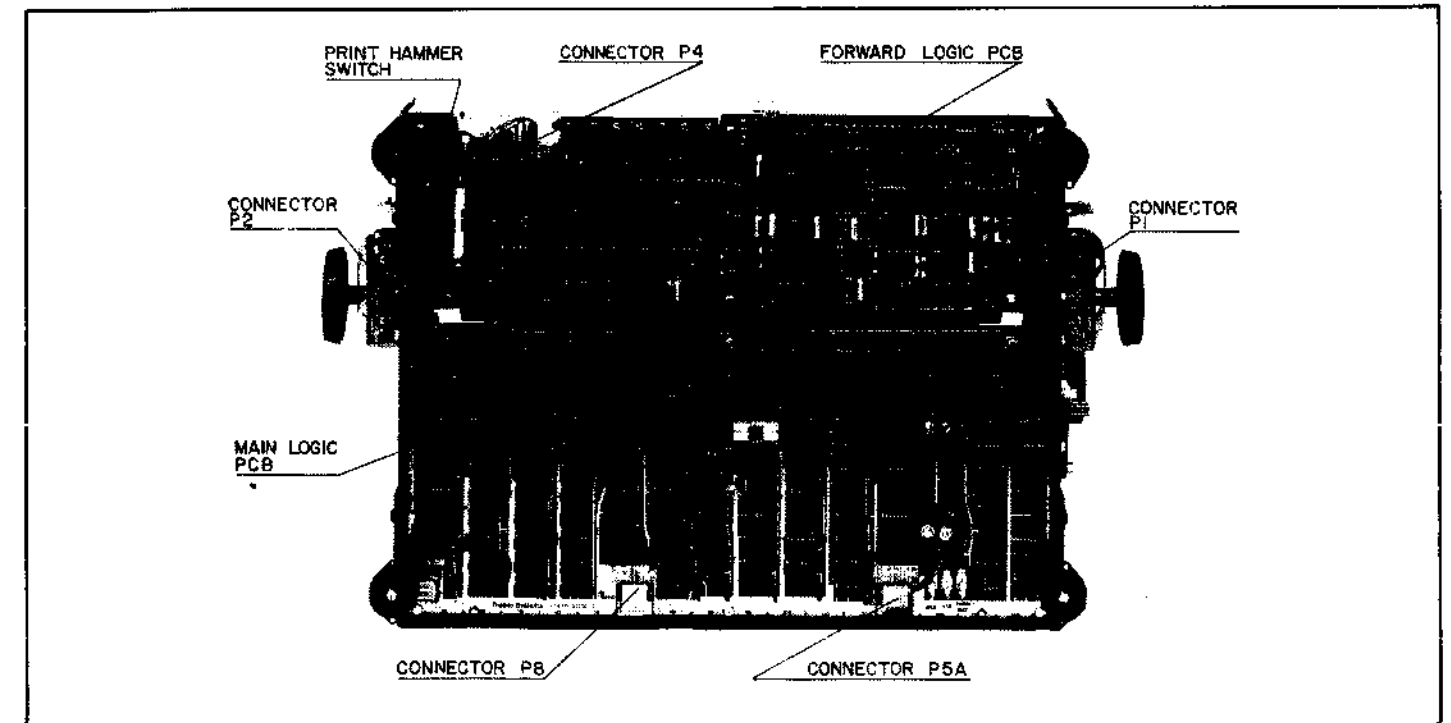

FIGURE 6-4

HYTYPE I PRINTER — MAJOR COMPONENT LOCATIONS — BOTTOM VIEW

6.4 PREVENTIVE MAINTENANCE — MAINTENANCE LEVEL 1

6.4.1 Preventive Maintenance Philosophy

The principle of maximum machine available time governs the preventive maintenance recommendations contained herein. Unless a procedure increases machine availability or enhances operation, it is not recommended. Except for the procedures outlined below, no maintenance or adjustment should be performed on a printer that is operating properly.

6.4.2 Preventive Maintenance Procedures

Scheduled or preventive maintenance should be performed after every 250 hours of printing time, or every three (3) months, whichever occurs first. Scheduled or preventive maintenance consists of visual inspection, cleaning, and lubrication as described here:

6.4.2.1 Cleaning and Inspection

- (1) Remove power from the unit. Open or remove covers as required to gain access to the unit.
- (2) Inspect the unit for signs of wear and loose or broken hardware. Check carriage cable for signs of wear, and cable pulleys for loose bearings. Check platen for looseness or wobble. Check platen drive gears for looseness. Check the carriage system for looseness, wobble, or accumulations of foreign material on the rails and/or wheels which might cause uneven movement of the carriage.
- (3) Remove platen, paper cradle, and paper feed rollers. Remove ribbon cartridge, print wheel, and column indicator. Inspect those for wear.
- (4) Clean the printer thoroughly, using alcohol saturated cleaning pads, and wipers. Remove accumulations of paper residue, ink, dust, etc., with special attention to the carriage rails and pulley grooves. Heavy deposits may be removed first by blowing with compressed air. Be sure to observe all safety precautions when using air.

NOTE: Use of compressed air for cleaning is not recommended where the printer is located close to other equipment sensitive to dirt and dust laden air.

Clean the platen, paper bail tires, and paper feed rollers with a good platen cleaner which is non-injurious to rubber products, such as "Fedron" Platen Cleaner.

6.4.2.2 Lubrication

Lubricate the various parts of the cleaned and inspected printer according to the following schedule. *DO NOT* exceed this schedule. Too much lubricant is often far worse than none at all!

- (1) *Paper Feed Motor* — no lubrication needed for the motor itself. Inspect the felt washer behind the large platen drive gear. If the felt is becoming white in color, saturate with #70364 Polyoil (light grease).
- (2) *Paper Feed Carrier Parts* — apply 1 drop of #70363 light oil to each pivot point, including the pressure release linkage. Arrange the rollers in their proper locations, and apply oil as above to each notched roller shaft bearing surface.
- (3) *Platen Assembly* — apply 1 drop of #70363 light oil to the bore of each moving part as required.
- (4) *Paper Bail* — Spray #70658 Molykote 557 on a wiper, and wipe the paper bail shaft from end to end. Move the paper bail rollers back and forth to spread this very light coating of lubricant to all parts of the shaft and roller bearing surfaces. Lightly spray each paper bail pivot point with Molykote 557, and wipe off the excess.
- (5) *Lower Carriage Assembly* — Spray a light coating of #70658 Molykote 557 on the carriage rails, while holding a wiper underneath them, to catch the excess spray. Apply 1 small drop of #70363 light oil to each pivot point and roller shaft on the carriage itself.
- (6) *Upper Carriage Assembly* — Apply 1 drop of #70363 light oil to the ribbon drive gear shaft, and the internal springloaded drive key. Spray a light coat of #70658 Molykote 557 on the print hammer, while working the hammer manually back and forth in its support shaft to spread the lubricant. Apply 2 drops of #70243 oil to each felt washer on the ribbon platform pivot shaft. Remove the rubber caps, and apply a small amount of #70364 Polyoil (light grease) to the ends of the hammer armature's pivot shaft.

6.5 CORRECTIVE MAINTENANCE

6.5.1 Corrective Maintenance Philosophy

Corrective Maintenance and repair may be divided into two periods — warranty and post-warranty. While the HyType I Printer's warranty remains in force, corrective maintenance by the user should normally be limited to Level 2 procedures, and Diablo Customer Service contacted for assistance with more serious problems.

NOTE: The Diablo warranty is null and void when any Level 2 or Level 3 procedure has been unsuccessfully attempted. All time and material required to restore the printer to working order will be billed at prevailing rates.

Beyond the warranty period, only the users capabilities and desires need govern the point at which Diablo technical assistance would be requested.

6.5.2 General Troubleshooting Techniques

CAUTION: Always remove power before making or breaking connections to or within the HyType I printer.

- (1) The Troubleshooting Flow Chart in Figure 6-5 may be used as a guide to quickly identifying trouble areas. Specific troubleshooting techniques outlined below, plus the information contained in the portion of Section 5 referenced in the Flow Chart should then aid the technician to quickly isolate defective components and/or out-of-tolerance conditions.
- (2) Appropriate servo drive signals may be generated for troubleshooting purposes while the printer is in CHECK (TP's 2-4-6-8/7-9/15-17) by actuating the appropriate switch, to remove detent power, and moving the member manually. The carriage is moved back and forth for combo board tests, while the print wheel is rotated for forward logic board tests.

If a servo drive transistor shorts, the resultant overload will destroy associated resistors. Suspect a shorted drive transistor when resistors show evidence of having been overheated.

When a defective FET is suspected, check the associated resistor pack before changing the FET pack, to determine if the gate signals are being developed.

Should replacement of a PCB or major sub-assembly become necessary, consult Section 6.7 for appropriate procedures and adjustments to be expected.

6.6 ADJUSTMENTS

6.6.1 Adjustment Requirements

No adjustments should be attempted unless an equipment malfunction indicates a specific need. The following list includes several field adjustments provided for in the HyType I Printer, along with an indication of the Maintenance Level suggested for each.

Adjustment or Requirement	Maint. Level
Card Guide/Ribbon Guide Alignment	2
Carriage Drive Cable Adjustment	3
Carriage Height (Print) Adjustment	3
Carriage Mechanical Stop Adjustment	3
Paper Feed Drive Gear Adjustment	3
Paper Feed Pressure Roller Adjustment	2
Platen Adjustments	3
Print Hammer Alignments	2
Print Intensity Adjustment	1
Print Wheel Alignment (Timing)	3
Print Wheel Home ("0") Adjustment	3
Ribbon Adjustments	3

6.6.2 Adjustments — Level I

6.6.2.1 Print Intensity Adjustment

This adjustment is a knurled knob just to the right of the print hammer. The adjustment has an effect range of 180° of rotation of this knob, which range can then be moved through the range of the knob's eccentric mounting shaft. Positioning the knob with its locator dot at the top (12 o'clock) produces maximum print intensity for any one setting of the shaft eccentric. Rotating the knob in either direction 180° to move the dot to the bottom (6 o'clock) position produces minimum print intensity for any one setting of the shaft eccentric. The user may select any position within the range of the knob which produces the desired print intensity. Adjustment of the shaft eccentric is a higher level activity.

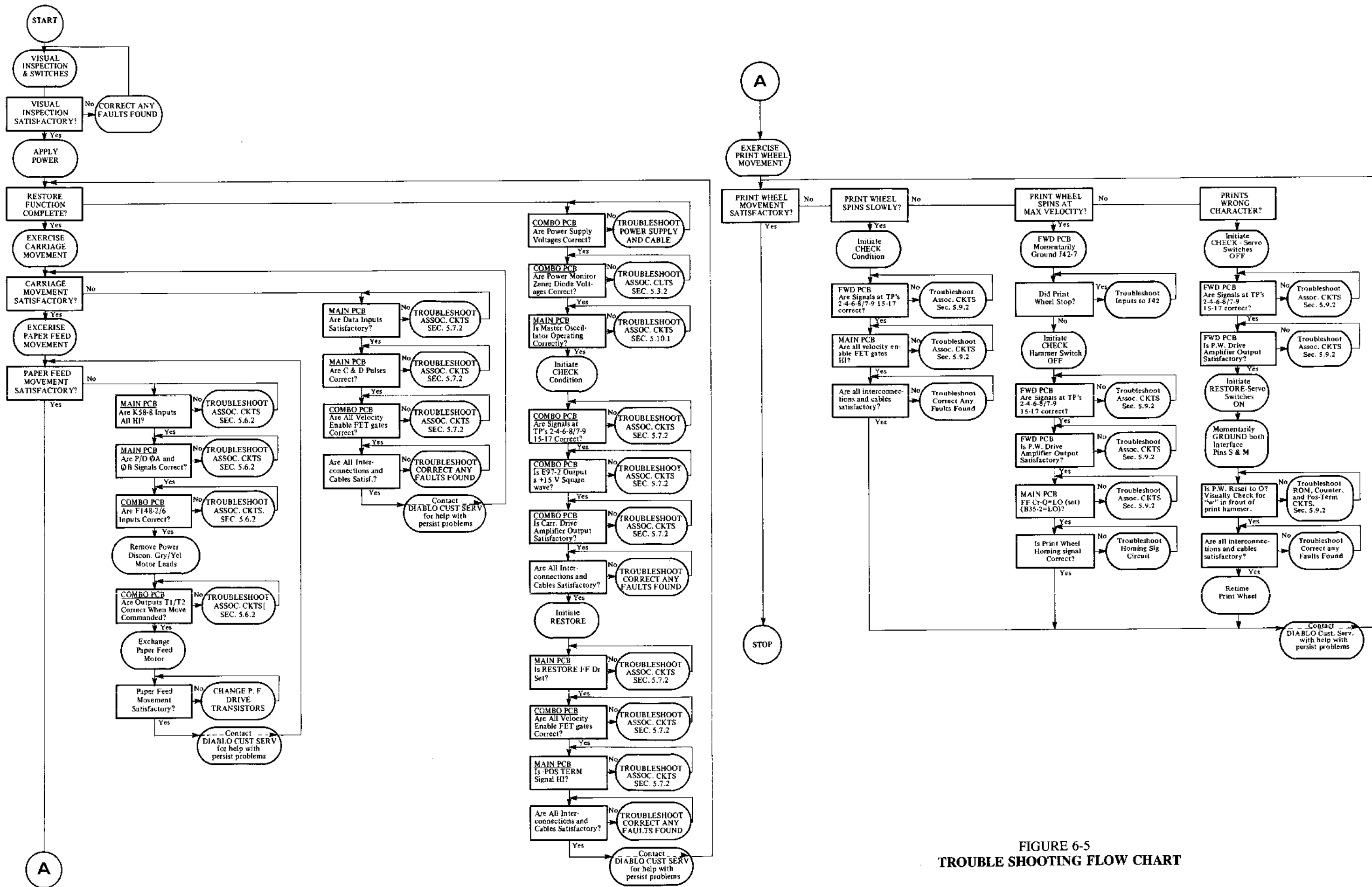

FIGURE 6-5 TROUBLE SHOOTING FLOW CHART

6.6.3 Adjustments — Level 2

6.6.3.1 Card Guide/Ribbon Guide Adjustment

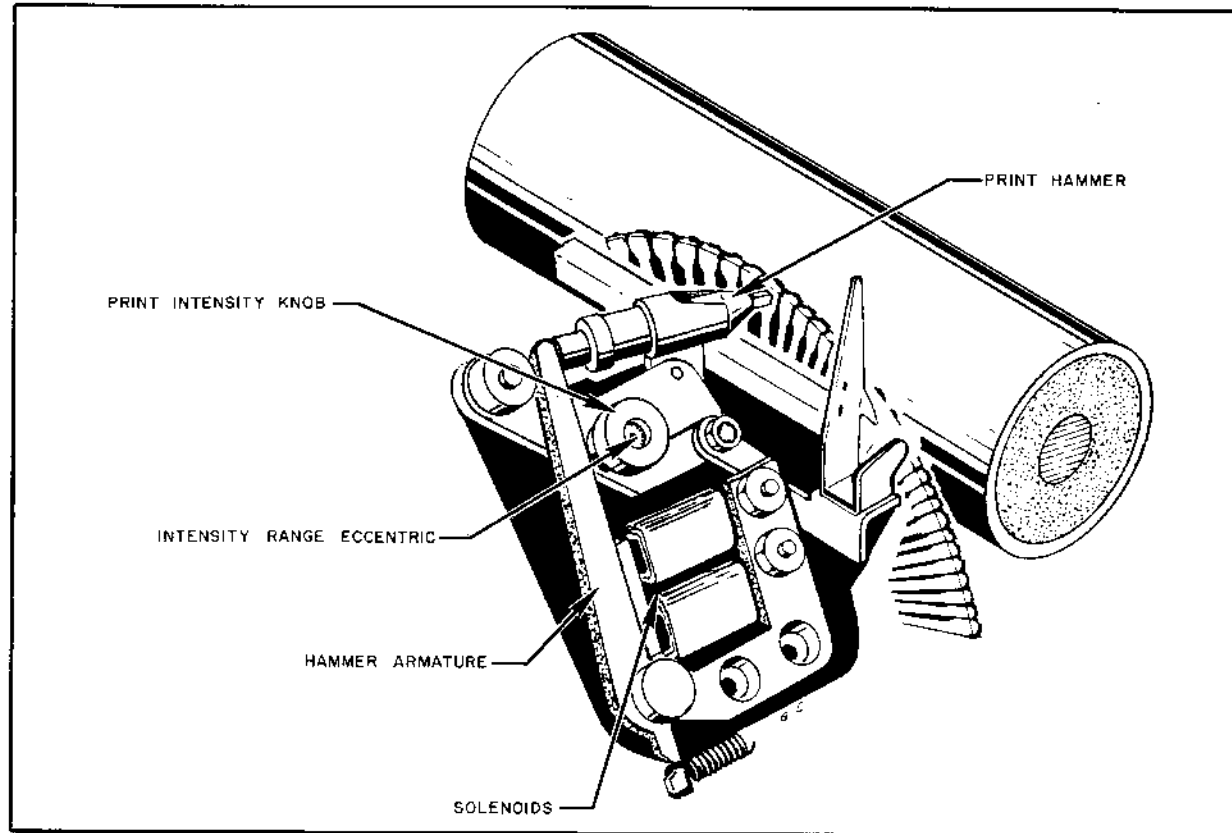

FIGURE 6-6
COMPONENT LOCATIONS — PRINT HAMMER ASSEMBLY

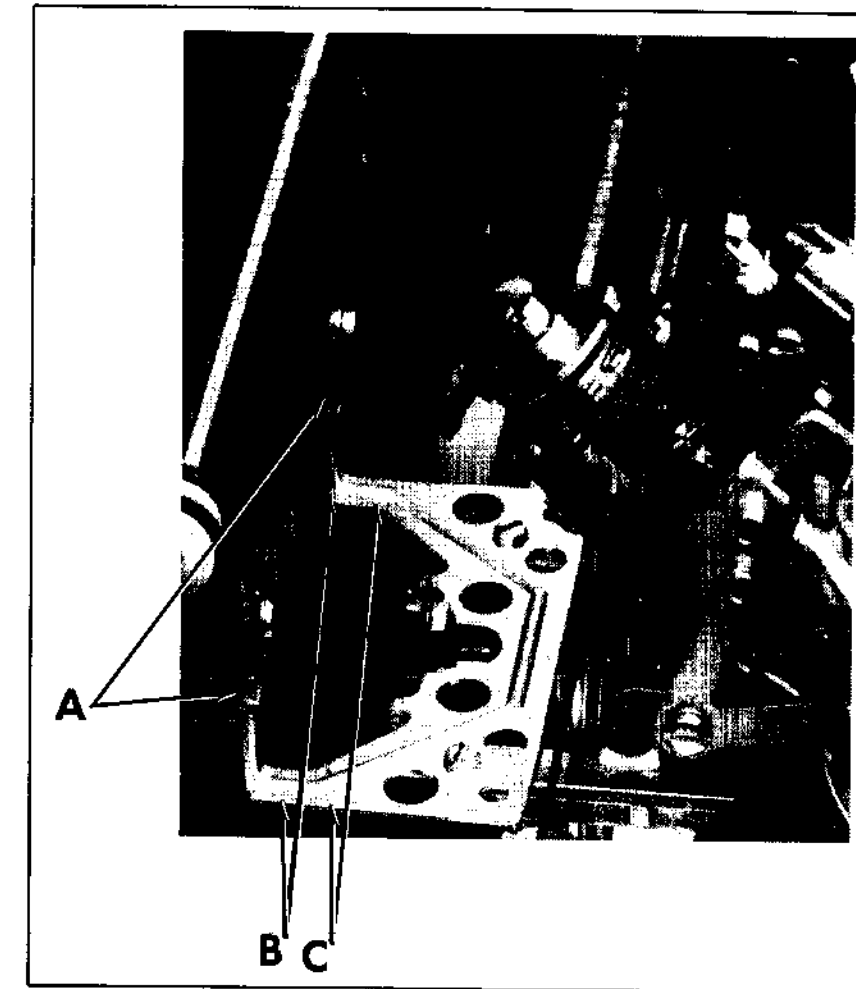

FIGURE 6-7
CARD GUIDE BRACKET ADJUSTMENT POINTS

- (1) The adjustments described below are to be accomplished by forming the left and right lower arms of the support bracket, as shown in Figures 6-7 and 6-8, at points A, B, and C, as necessary to bring the card guide into position. Note that the ribbon guide may be moved slightly to aid card guide adjustment.
- (2) Figure 6-8 illustrates the objectives of this procedure, and establishes the minimum clearances required, as viewed from the side. Figure 6-9 illustrates the final location objectives of the procedure for the card guide.
- (3) The Card Guide is moved into correct position so that the small lower tabs on the ribbon guide gently contact the Card Guide and the upper guide posts are .006" to .020" from the guide when the carriage is locked in its operating position, with other clearances maintained.

6.6.3.2 Paper Feed Pressure Roller Adjustment

- (1) Check for a downward spring tension of between 2.5 and 3.0 pounds at four points (A). The tension on each of the four arms must be within 3 ounces of the others. Adjust spring tension by moving the appropriate spring hook to the correct arm slot (B).
- (2) With the pressure release lever forward, check for a minimum gap of .050" at six points (C) and (D). Adjust the gap at points (C) by adjusting arm (E) after loosening clamp bolt (F). Adjust the gap at points (D) by adjusting the eccentric (G).
- (3) With the pressure release lever in its rear or operating position, and with a .003" shim installed at points (H), check for a minimum and even gap between the rollers and the platen. Readjust arm (E) and eccentric (G) as required to achieve this.

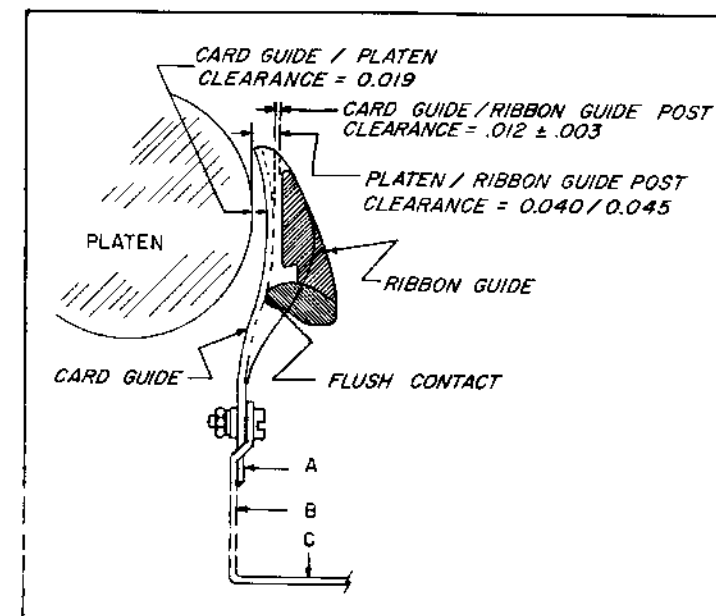

FIGURE 6-8
CARD GUIDE CLEARANCES AND ADJUSTMENTS

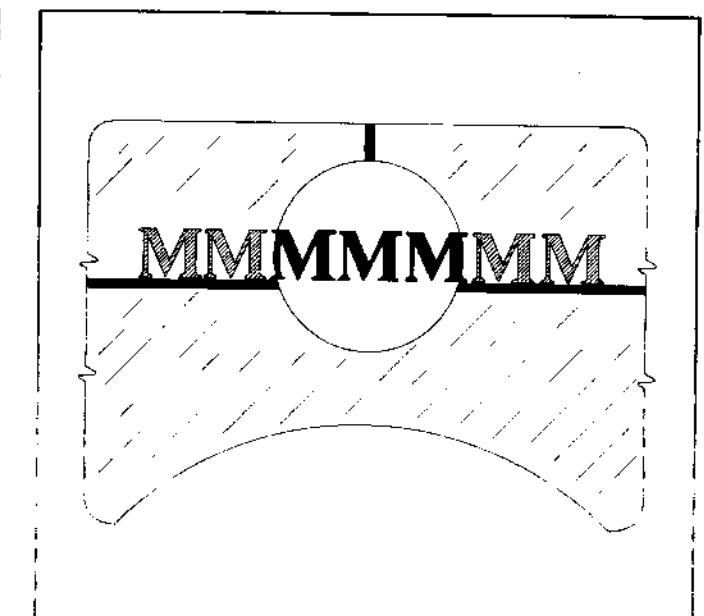

FIGURE 6-9
CARD GUIDE ALIGNMENT ILLUSTRATION

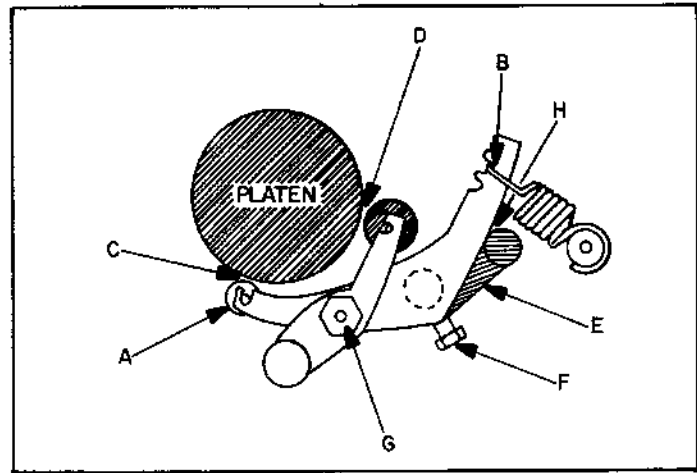

FIGURE 6-10
PLATEN PRESSURE ROLLER ADJUSTMENT

6.6.3.3 Print Hammer Alignments

For correct print hammer alignment, the following procedures should be performed in sequence:

6.6.3.3.1 Align the Print Hammer

- (1) Remove the ribbon cartridge, and print wheel.
- (2) Refer to Figure 6-11. Loosen the two hammer mounting screws slightly.
- (3) Place the #22647 Hammer Adjuster Fixture (#20997 for 7° hammer installation) on the print wheel hub, as shown, hold it in place with the #31100 Holding Cap.
- (4) Rotate the fixture over the hammer. Move the hammer assembly as necessary until the hammer tip and anvil areas just touch the fixture contact points.
- (5) Retighten the hammer mounting screws, being careful not to move the hammer assembly.

6.6.3.3.2 Align the Print Hammer/Armature Assembly

- (1) Remove the Print Intensity Knob, Intensity Range Eccentric, and the Armature Spring.
- (2) Loosen the three #6-32 socket head screws A1, A2, and A3.

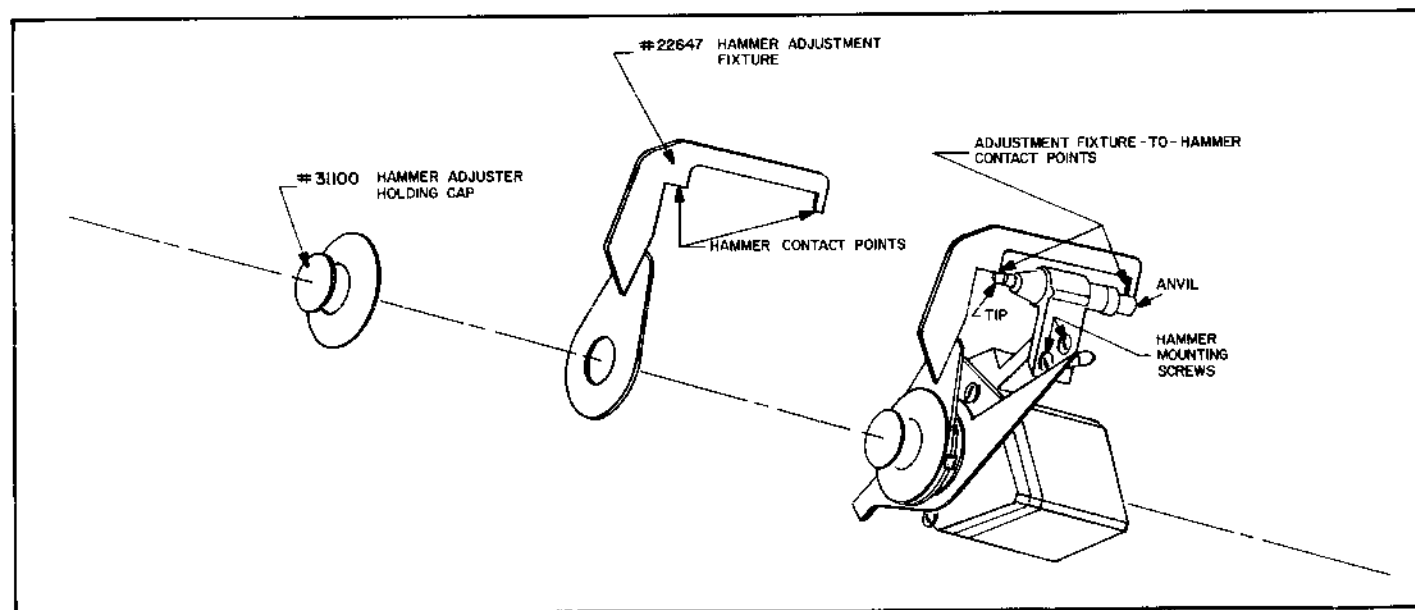

FIGURE 6-11
PRINT HAMMER ALIGNMENT

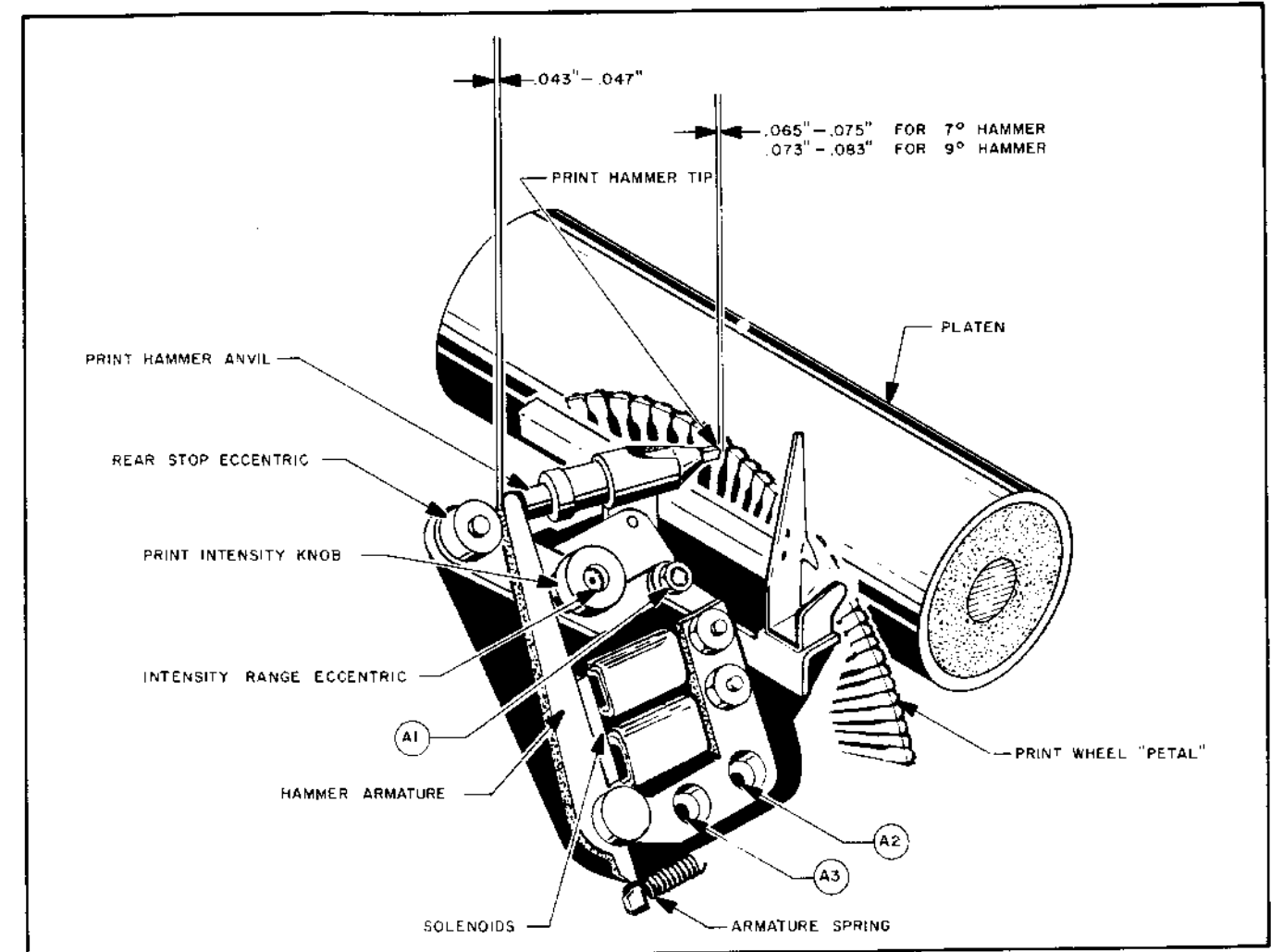

FIGURE 6-12
PRINT HAMMER ALIGNMENT

- (3) With a print wheel installed, and the carriage locked down in its operating position, place a .078" guage between the print wheel petal in front of the hammer, and (.070" for 7° hammer) the platen.
- (4) Push the hammer armature back to press the hammer tip gently against the print wheel guage and platen. Retighten the three #6-32 socket head screws A1, A2, and A3. Recheck the gap between the hammer-print wheel petal-platen. It should be .078" ± .005" (.070" ± .005" for 7° hammer). Replace the armature spring.
- (5) Inspect the #20436 Intensity Range Eccentric. Mark its top, with a soft pencil, to indicate the approximate location of the perigee of the shaft eccentric.
- (6) Reinstall the Print Intensity Knob on the Range Eccentric, and then these two on the print hammer frame. Orient the eccentric with its mark toward the hammer armature, and tighten its hold-down nut just enough to hold it, and still allow the eccentric to be moved.
- (7) Set the Print Intensity Knob at 1 o'clock. Hold the armature against the solenoids, and check that the knob skirt just touches the armature, adjusting the range eccentric as required to achieve this.
- (8) Rotate the Print Intensity Knob to its 3 o'clock (away from the armature) position. Hold the armature against the intensity knob, and adjust the Rear Stop Eccentric for a clearance of .045" ± .003".
- (9) Reinstall the ribbon cartridge, and armature spring. Operate the printer, and adjust the Print Intensity Knob for desired print quality.
- (10) If print out is too light, even with the knob at 12 o'clock and a new ribbon, repeat steps 1-8 above, setting the clearance in step 4 to .073" (.065" for 7° hammer). If the print out is too heavy, even with the knob at 6 o'clock, reset the intensity eccentric in step 6 a small amount in either direction until the desired range of adjustment for the

knob is achieved. If, after 180° of rotation of the eccentric, a light enough print out is not achieved, adjust the step 4 clearance to .083" (.075" for 7° hammer).

6.6.4 Adjustments — Level 3

6.6.4.1 Carriage Drive Cable Adjustment

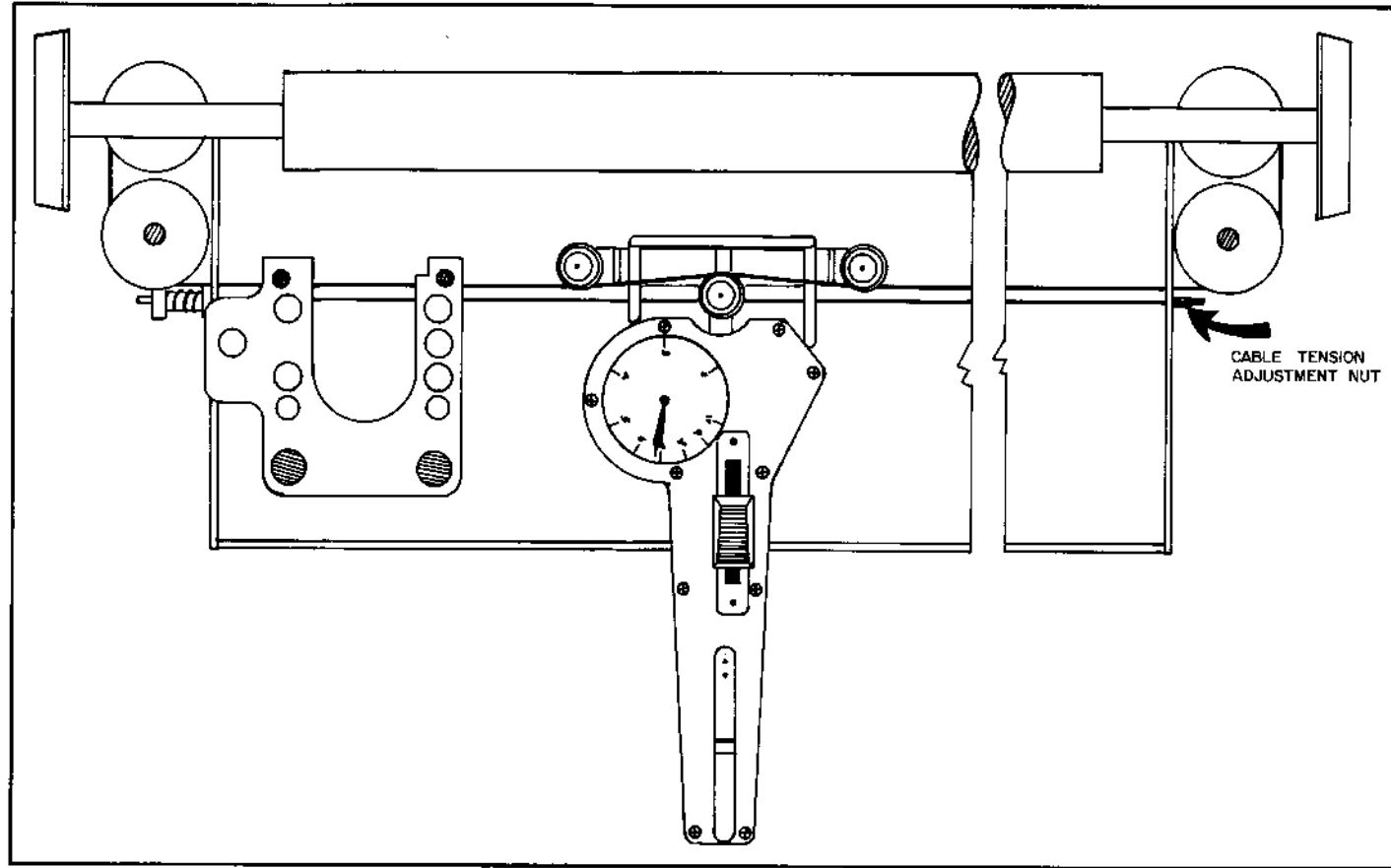

FIGURE 6-13
CARRIAGE DRIVE CABLE ADJUSTMENT WITH TENSIONMETER

- (1) Remove power from the printer, and disconnect the power connector (this is a safety measure).
- (2) Position the carriage against the left mechanical stop, as shown in Figure 6-13.
- (3) Install the Cable Tensiometer on the carriage cable as shown. The dial should indicate between 6.75 and 7.22 Kg. Adjust the #70347-05 (#5-40) locknut on the RH side to produce the desired cable tension.
- (4) If an adjustment was necessary, remove the tensionmeter, and move the carriage back and forth at least twice to resettle the cable. Recheck the cable tension to ensure that it has not changed.

6.6.4.2 Carriage Height (Print) Adjustment

This is a factory adjustment, and should not require readjustment for the life of the carriage.

6.6.4.3 Carriage Mechanical Stop Adjustments

- (1) Using the #20993 Mechanical End Stop Adjustment Fixture as shown in Figure 6-14, adjust the LH Mechanical Stop to the .785" dimension with its adjustment screw.
- (2) Apply power to the printer, and observe a complete RESTORE cycle. If the carriage stopped against the LH mechanical stop, check Main Logic PCB N70-6. If this signal is LO, readjust the LH End Stop adjustment slightly, and recycle the RESTORE function until N70-6=HI.
- (3) With the carriage at its "home" position following a completed RESTORE sequence, step the carriage to the right 792 increments. Adjust the RH Mechanical End Stop for .020" clearance between itself and the right side of the carriage lower frame. Initiate a RESTORE sequence, and step the carriage to the right 793 increments. The printer should enter a CHECK condition.

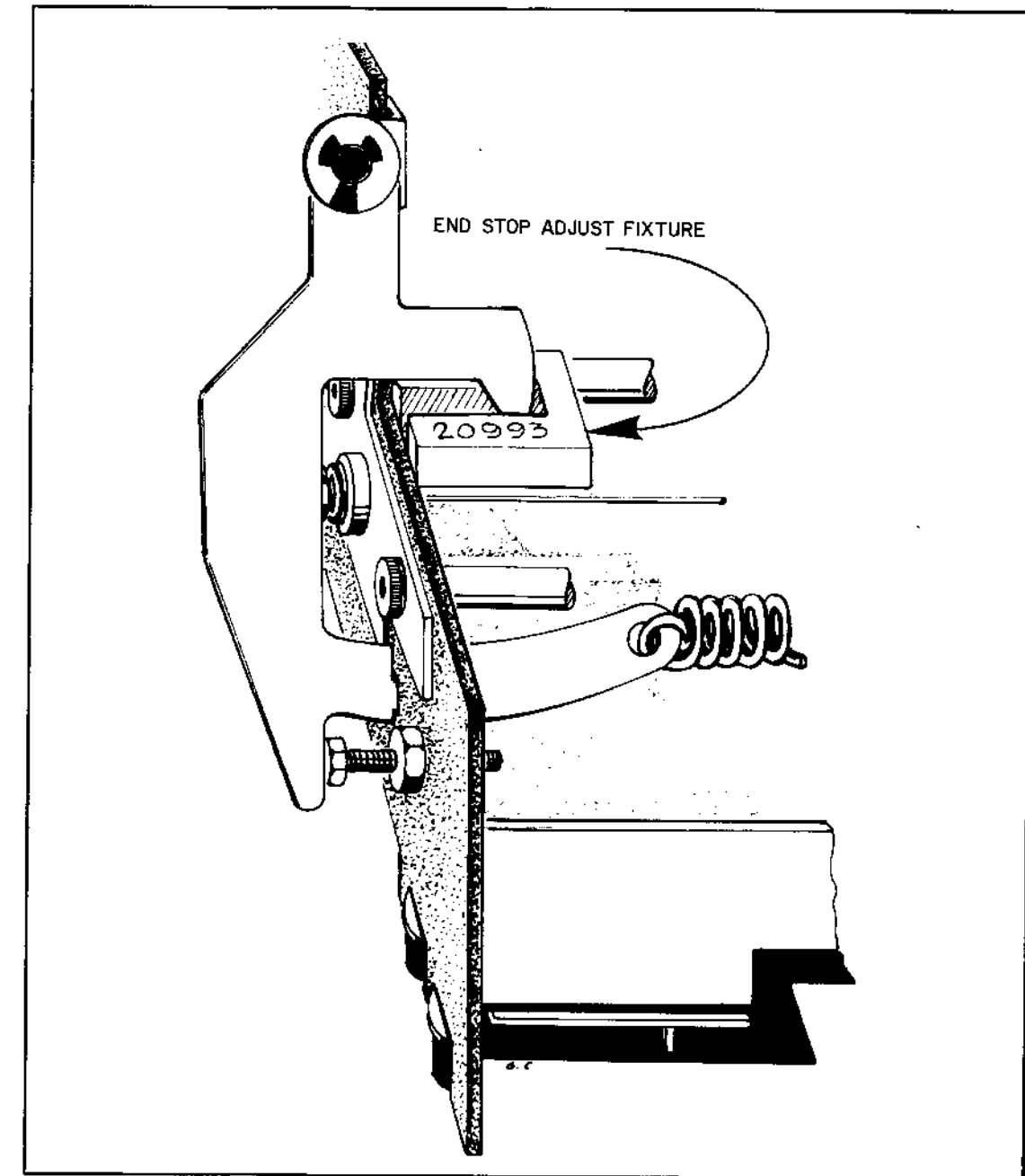

FIGURE 6-14
CARRIAGE LEFT MECHANICAL STOP ADJUSTMENT

6.6.4.4 Platen Adjustments

6.6.4.4.1 Horizontal Adjustment — Refer to Figure 6-15.

- (1) Remove power from the printer. Remove the ribbon cartridge, print wheel, and card guide. If the card guide is not installed and the printer has the long skirted paper cradle, remove the cradle also, replacing the platen. Remove the paper feed intermediate drive gear.
- (2) Install the #20994 Print Wheel Adjustment Fixture on the print wheel hub, and hold it in place with the #31100 Cap.
- (3) Lock the carriage down in its operating position.
- (4) Refer to Figure 6-15. Check for proper clearance between the fixture and the platen. It should be .000"/.005" maximum gap along the length of the platen. If it is not, proceed with the next steps.
- (5) Loosen the platen release eccentric locking screw, the pivot stud nut, and the vertical and horizontal eccentric

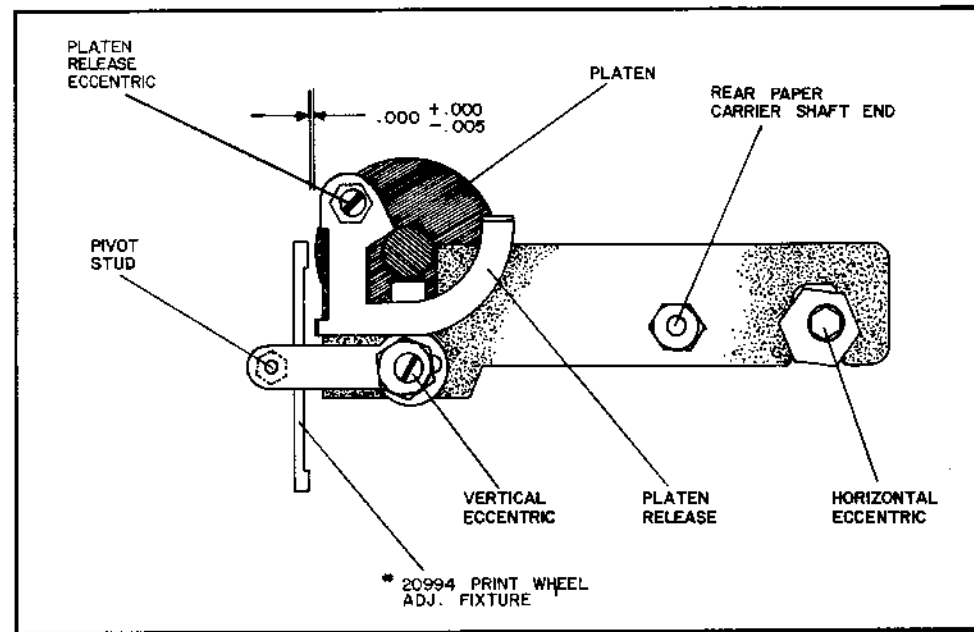

FIGURE 6-15
PLATEN HORIZONTAL ADJUSTMENT

locking screws all on both sides of the printer, and the screws holding the black brackets to the printer frame in the middle of the carrier assembly.

- (6) While applying downward pressure on the rear paper carrier shaft, adjust the horizontal eccentric on both sides of the printer to achieve the desired fixture-platen clearance.
- (7) Lock the horizontal eccentrics by tightening down their locking screws, and remove the fixture. Reinstall the Card Guide, unless an upper carriage alignment check is to be made.

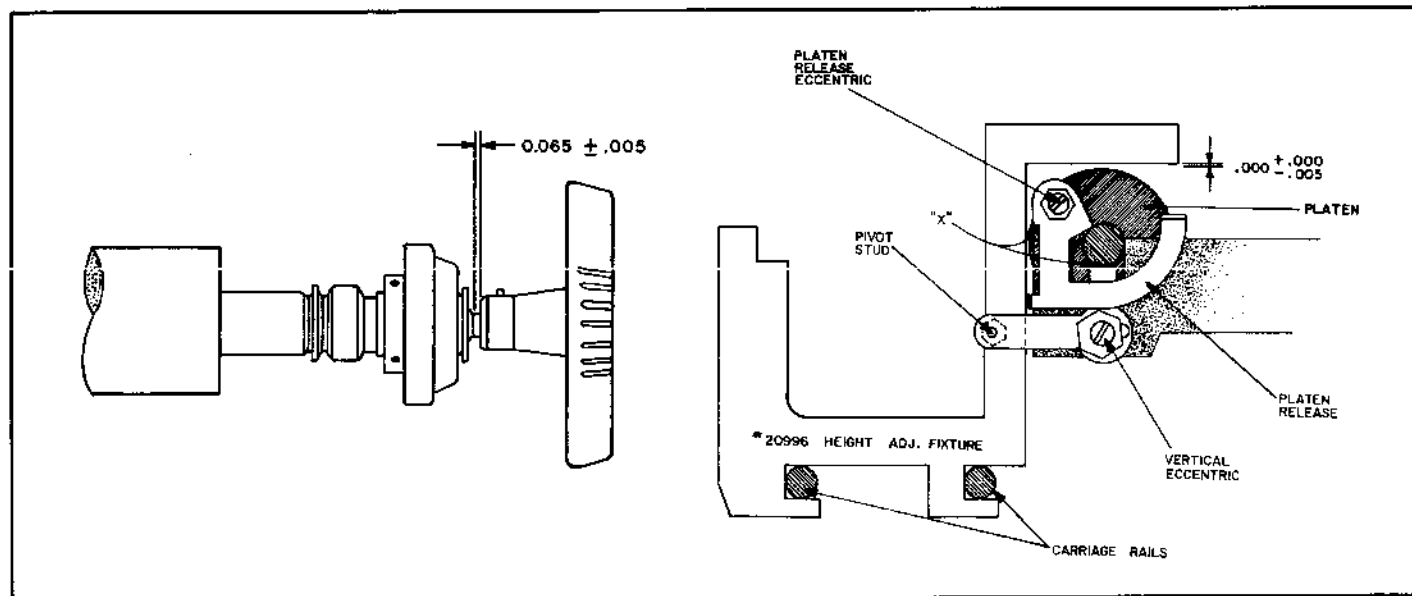

FIGURE 6-16
PLATEN VERTICAL ADJUSTMENT

6.6.4.4.2 Vertical Adjustment — Refer to Figure 6-16.

- (1) Position a #20996 Height Adjustment Fixture on the carriage rails at each end of the platen. Pull the paper feed release lever forward.
- (2) Adjust the vertical eccentric on each side of the printer to achieve a .000" to .005" maximum clearance between the fixture and the platen at each end.

- (3) Lock both vertical eccentrics by tightening their locking screws, and tighten down the pivot studs.
NOTE: If an upper carriage alignment is to be made, leave the fixtures in place, otherwise remove them.
- (4) Reinstall the paper feed intermediate drive gear, and perform adjustment procedure 6.6.4.6.

6.6.4.4.3 Platen Release Adjustment — Refer to Figure 6-16.

After horizontal and vertical platen adjustments have been made, adjust the platen release eccentrics on both sides to obtain a clearance of .010" at points "X" with paper feed pressure released. Lock the eccentrics with their locking nuts.

6.6.4.5 Ribbon Adjustments

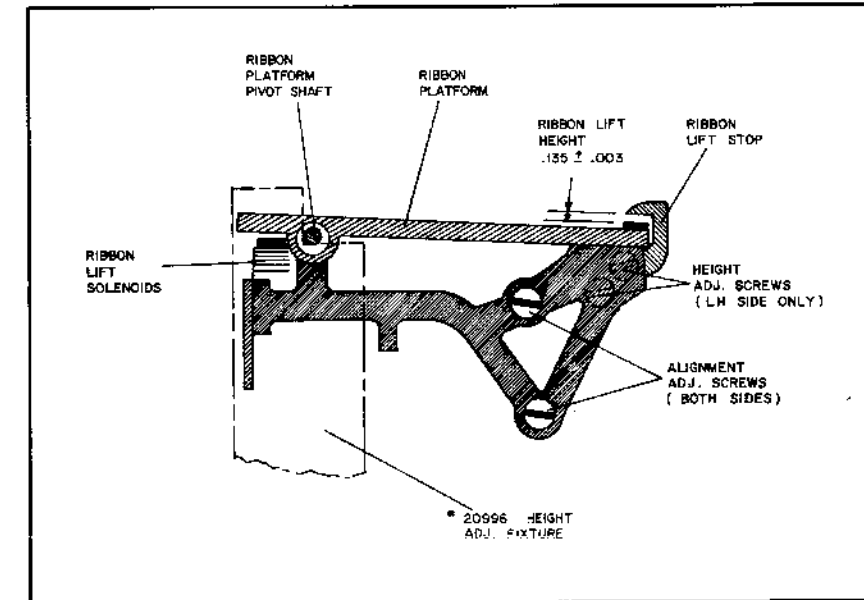

FIGURE 6-17
RIBBON PLATFORM ADJUSTMENT

6.6.4.5.1 Ribbon Platform Alignment

- (1) If not already in place, position a #20996 Height Adjustment Fixture on the carriage rails on either side of the carriage. Remove the card guide if installed.
- (2) Slide the fixtures up against each side of the carriage. Check that the ribbon platform pivot shaft ends fit snugly into the corners of the notches in the figures as shown.

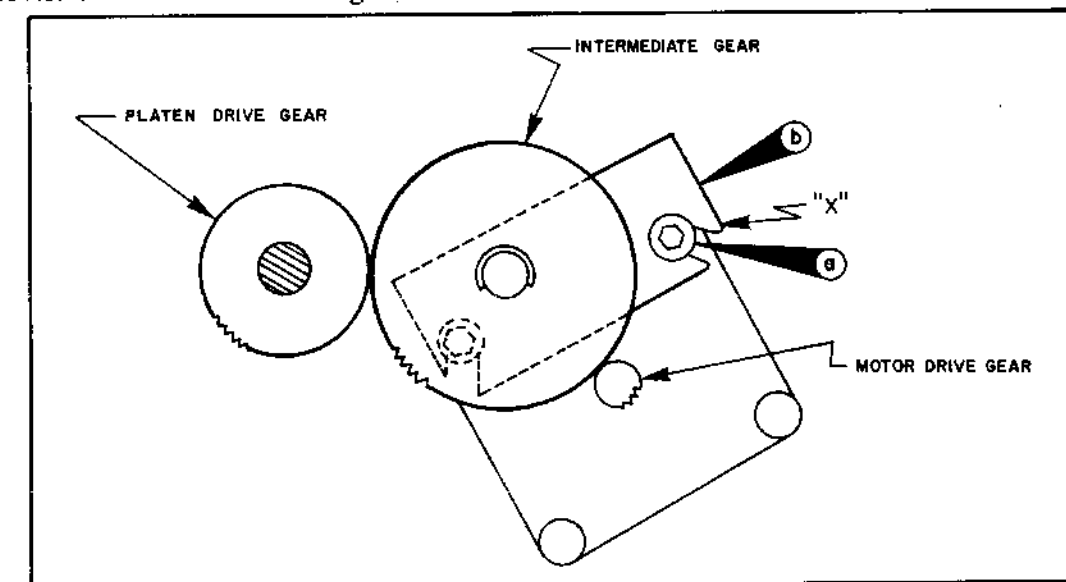

FIGURE 6-18
PAPER FEED DRIVE GEAR ADJUSTMENT

- If necessary, loosen the two alignment screws on each side of the upper carriage assembly, and reposition the assembly to achieve the requirements of step 2 above. Retighten the adjustment screws.

6.6.4.5.2 Ribbon Lift Height Adjustment

- With the ribbon platform held down, check for proper clearance between the platform and the lift stop.
- If necessary, loosen the height adjustment screws and adjust the ribbon lift stop for proper clearance. Retighten the screws.

NOTE: Clearance measurements are from the underside of the stop to the top of the soft shock absorbent patch.

6.6.4.6 Paper Feed Drive Gear Adjustment

- The paper feed intermediate drive gear is to be adjusted for .001/.004" maximum play between itself and the motor drive gear, while maintaining a minimum of play between it and the platen drive gear.
- Loosen the two screws (a) which hold the intermediate drive gear's mounting plate (b) to the printer.
- Hold up on the mounting plate at point "X" while rotating the platen in the direction shown. Tighten down on the mounting screws (a). The minimum backlash (or play) between the motor drive gear and the intermediate drive gear is .001", maximum is .004". There should be no backlash between the intermediate and the platen drive gears.

6.6.4.7 Print Wheel Home "0" Adjustment

Adjustment of the print wheel "0" is performed in two steps. The magnetic transducer must first be adjusted to detect the small metal slug located in the rotating disk on the back of the print wheel servo motor. The position of this slug corresponds to the home "0" position (small w) on the print wheel. After the magnetic transducer has been positioned, the Print Wheel mounting hub is positioned to locate the print wheel guide tab at the proper position.

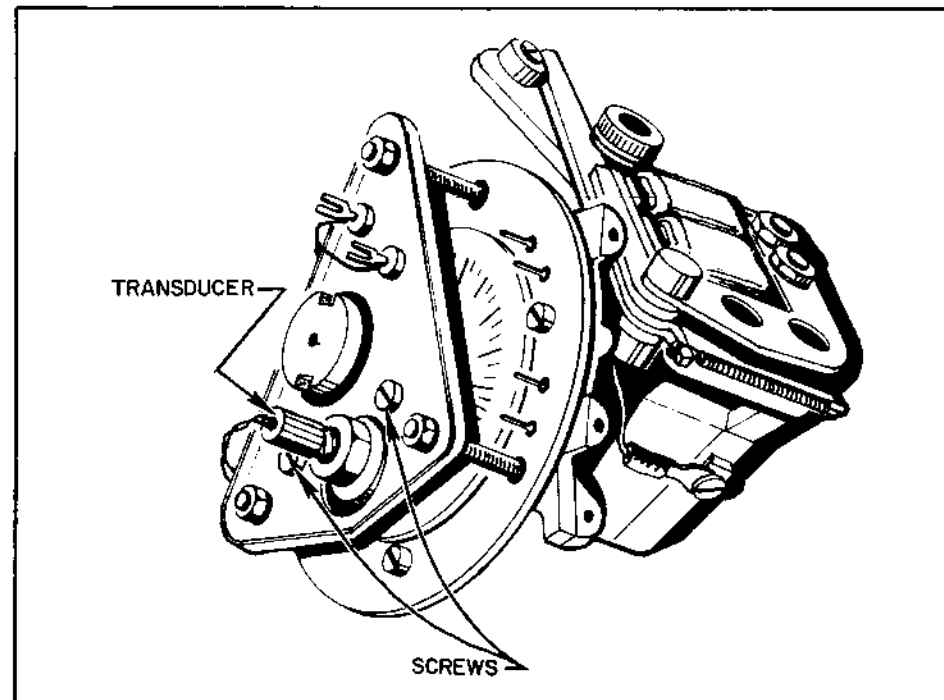

FIGURE 6-19
PRINT WHEEL HOME "0" ADJUSTMENT

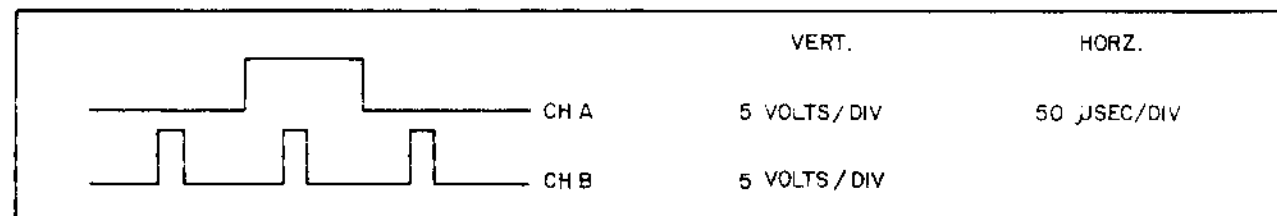

FIGURE 6-20
PRINT WHEEL TRANSDUCER WAVEFORMS

- To adjust the magnetic transducer, loosen the two securing screws clamping the transducer to the mounting plate. Connect an oscilloscope to the locations listed below, and adjust the transducer until the waveforms are as shown in Figure 6-20, and then tighten the securing screws. Position the transducer so that only one pulse of CH B is centered within the positive portion of CH A.

Channel A Probe to D95-9
Channel B Probe to D95-10
Ground D70-3
(all on Main Logic PCB)

The print wheel should spin when power is applied. After the transducer has been positioned properly, disconnect the oscilloscope. After performing this adjustment, always perform a Print Wheel Alignment, as outlined in Section 6.6.4.8 below.

6.6.4.8 Print Wheel Alignment (Timing)

- Remove the ribbon cartridge, print wheel, and card guide if installed.
- Install the #20994 Print Wheel Adjustment Fixture on the print wheel motor hub, and hold it in place with the #31100 Holding Cap.
- With power applied to the printer, momentarily ground the RIBBON LIFT input line (M) while holding the SELECT PRINTER input (S) grounded on input connector P7.
- Verify that the print wheel fixture has stopped with its edge slot in front of the print hammer, and that the print hammer will move forward into the slot with equal clearance on each side.
- If the Print Wheel Fixture-to-Print Hammer alignment is not satisfactory, loosen the print wheel hub using the #20399 Hub Fixture, and reposition the print wheel fixture for correct alignment with the hammer. Retighten the print wheel hub nut securely.

NOTE: Print wheel alignment will normally be necessary ONLY when the print wheel motor has been changed.

6.7 REMOVAL AND REPLACEMENT OF ASSEMBLIES

6.7.1 Level 1

Except for ribbon cartridges and print wheels, no replacement of assemblies and/or parts is included at this level. Exchange of ribbons and print wheels has been discussed earlier in the section on Operating Instructions.

6.7.2 Level 2

Replacement of the platen, the paper feed rollers, and the paper cradle are included at this level, as well as exchange of printed circuit boards.

- As an aid to troubleshooting, and more rapid PCB exchange, power distribution has been color coded throughout the printer. In all instances:
 - Black or Dark Gray tubing over flat braid is ground.
 - Red is + 15 volts.
 - Blue is - 15 volts.
 - Orange is + 5 volts.
- The platen, the paper feed rollers, and the paper cradle are replaced by simply removing the old and installing the new. Since platens are manufactured to close tolerances, and are fairly firm, it may not be necessary to perform major alignment and adjustment procedures when replacing the platen. Readjustment of the paper feed section may be required, however, due to the relative softness of the rollers and the constant pressure on them. A decision to readjust will be arrived at empirically. If readjustment is required, refer to Section 6.6.3.2 in this manual.
- Removal of the Main and Forward PCB's requires only unplugging connectors, and removal of mounting screws (11 for the Main PCB, and 10 for the Forward PCB). Installation is in reverse order. Refer to the "Bring-Up" procedures in Section 5 below when exchanging Forward or Combo PCB's.

CAUTION: Note the orientation of the plug connecting the carriage assembly to the Forward PCB. This plug is not keyed.
- Removal of the Combo PCB/Heat Sink Assembly is as follows. Remove the two screws at the top L and RH outside corners of the heat sink. The assembly will now hinge down. Unplug the wires (17 in all) and the 2 connectors. Remove the screw securing the folding cable to the side frame, and the two screws on each side of the two hinges. The assembly may now be removed and replaced.

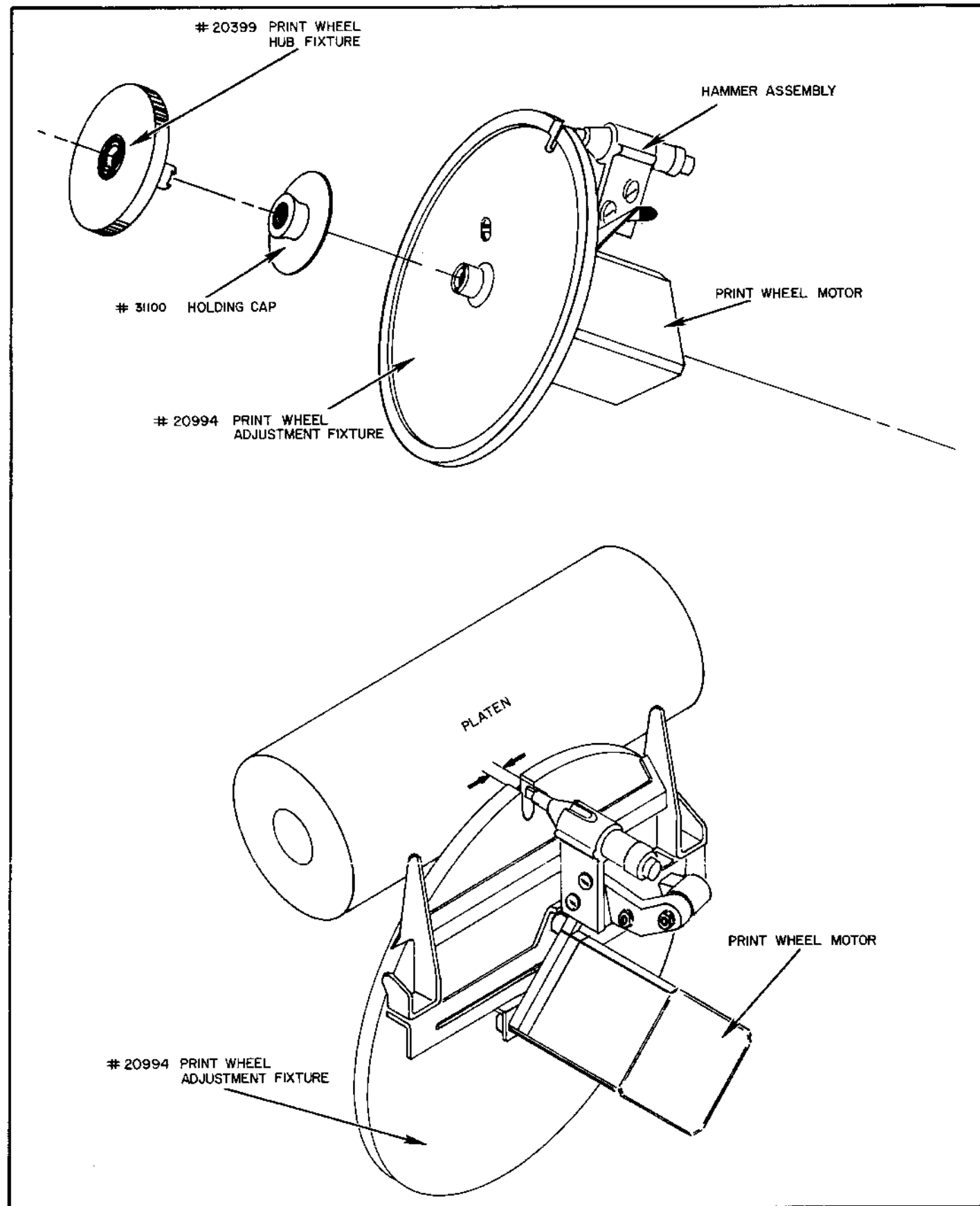

FIGURE 6-21
PRINT WHEEL ALIGNMENT

NOTE: On some units, the paper feed motor has two sets of twisted pair wire leads which plug into the PCB. If these PAIRS of wires are reversed, the paper feed motor will feed in the wrong direction. Color coding of the pairs is listed below:

Black/Gray	Orange/Yellow
T1	T2
T4	T3

On those units with single wires, the color coding is as listed below:

Gray	Yellow	Red	Black
T1	T2	T3	T4

- (5) When a new COMBO or FORWARD PCB is installed in a unit, the "Gain" and "Offset" must be adjusted to match the carriage or Print Wheel Servo systems with the new boards. These adjustments are called "Bring-Up" procedures and are detailed below:

NOTE: These adjustments should also be checked, whenever a board is exchanged between units, or a new carriage servo motor is installed.

Special tools and conditions required:

- An Oscilloscope.
- An Ohmmeter.
- A 10K potentiometer with wire leads attached to the center and one outside terminal.
- A 1 Megohm potentiometer with wire leads attached to the center and one outside terminal.
- Applicable Servo Disable Switch in the "Disable" position.
- Where the statement "insert a ¼ watt, 5%, resistor of equal value" is made, the nearest standard value may be used.

A. Setting the gain for test points 2,4,6 and 8, COMBO PCB's.

- Connect a scope probe to test point 4.
- Insert the 10K pot leads in location F47.
- While moving the carriage manually, adjust the pot (50 Ohms minimum) for a sine wave, 15 volts peak-to-peak on the scope.
- Remove the pot, measure its resistance, and insert a ¼ watt, 5% resistor of equal value.
- Move the scope probe to test point 8.
- Insert the 10K pot leads in location E46.
- Repeat (c) and (d).
- Insure that there is no more than .2 volt difference between any two of the four test points (2, 4, 6 and 8).

B. Setting offset for test points 2,4,6 and 8, COMBO PCB's.

- Connect the scope probe to test point 4.
- Insert the 1 Megohm pot leads in location H19.
- While moving the carriage manually, adjust the pot (1K minimum) so that one-half of the 15 volt sine wave is above the "X" axis on the scope, and the other half is below the "X" axis.
- Remove the pot, measure its resistance, and insert a ¼ watt 5% resistor of equal value.
- Move the scope probe to test point 8.
- Insert the 1 Megohm pot leads in location F19.
- Repeat (c) and (d).
- Insure that there is no more than .2 volt peak-to-peak difference between any of the four test points (2, 4, 6 and 8) with the "X" axis as a 0 volts reference.

C. Setting the gain for test points 2,4,6 and 8, FORWARD PCB.

Follow the same procedure as "A" above, except that the resistor locations are H139 and E139.

D. Setting the offset for test points 2,4,6 and 8, FORWARD PCB.

Follow the same procedure as "B" above, except that the resistor locations are J132 and E120.

6.7.3 Level 3

6.7.3.1 Carriage Assembly Replacement

The two flex cables containing the signal wires must be disconnected by loosening the clamps on their lower ends and unplugging them from the Forward PCB. Note the orientation of plug P4 for later reconnection.

The carriage assembly rides on guide rods, and is secured to them with three roller bearings which are spring loaded to maintain a constant pressure. Remove the nuts which hold the bearing arm to the lower assembly. Disconnect the two drive cables by pressing in on the tensioning spring on the left side frame, and slipping the cable off the guide pulleys on one end. This will allow enough slack to disengage the cable from the drive motor pulley and pull each back through the guide pulleys and the lower carriage assembly. The entire carriage assembly may now be lifted free.

NOTE: Observe how the cables come off for later replacement. Assemble in reverse order. When reassembled, check cable tension as outlined in Section 6.6.4.1 above.

6.7.3.2 Carriage Drive Motor Replacement

Disengage the carriage drive cable, as outlined in the section above. Disconnect the wires going to the motor, making note of how they were connected.

Remove the upper #70316-05 ¼" x 8-32 Hex Head screw, and the lower #20574 5/16" x 8-32 Hex Head stud, and remove the motor.

Reverse these steps to reinstall a replacement motor. Check the drive cable tension, and adjust as necessary, per Section 6.6.4.1 above.

6.7.3.3 Paper Feed Motor Replacement

Remove the paper feed intermediate drive gear. Remove the two top #70316-06 ¼" Hex Head screws, and the #20459 mounting plate. Remove the bottom two #70316-06 Hex Head screws. Disconnect the four motor leads, and lift the motor out of the printer. Be careful not to lose the four #20460 ¼" x #8 spacers from behind the motor mounting flanges.

Reverse these steps to reinstall a replacement motor. Perform a paper feed drive gear adjustment, per Section 6.6.4.3.6 above. Do not over-tighten the hold-down screws when mounting the motor.

6.7.3.4 Carrier Assembly Replacement

Remove the platen, paper cradle, paper feed pressure rollers, and the paper feed intermediate drive gear and its mounting plate.

Remove the paper bail pivot stud, horizontal and vertical adjustment eccentric screws on each end of the frame. Remove the two vertical #70315-01 ¼" Hex Head screws from each of the two mid-frame carrier braces. Lift the carrier assembly out of the printer.

Reinstall a replacement carrier assembly by reversing these steps. Perform platen alignment and pressure roller adjustments per Section 6.6 above.

SECTION 7 LOGIC DIAGRAM CONVENTIONS LOGIC DIAGRAMS

7.1 GENERAL

Diablo Systems logic diagrams are primarily intended for use by field service personnel as troubleshooting aids and by system design engineers as sources of design theory information. As such, the first responsibility of a set of logic diagrams is to illustrate a design's principles of operation. For this reason, Diablo Systems logic diagrams emphasize the functions performed by the logic elements in a design rather than the kinds of devices used to implement the functions.

For example, a NAND gate may appear on a Diablo Systems logic diagram as either a positive logic AND function with the output inverted (NAND) or as a negative logic OR function with the inputs inverted (NOR).

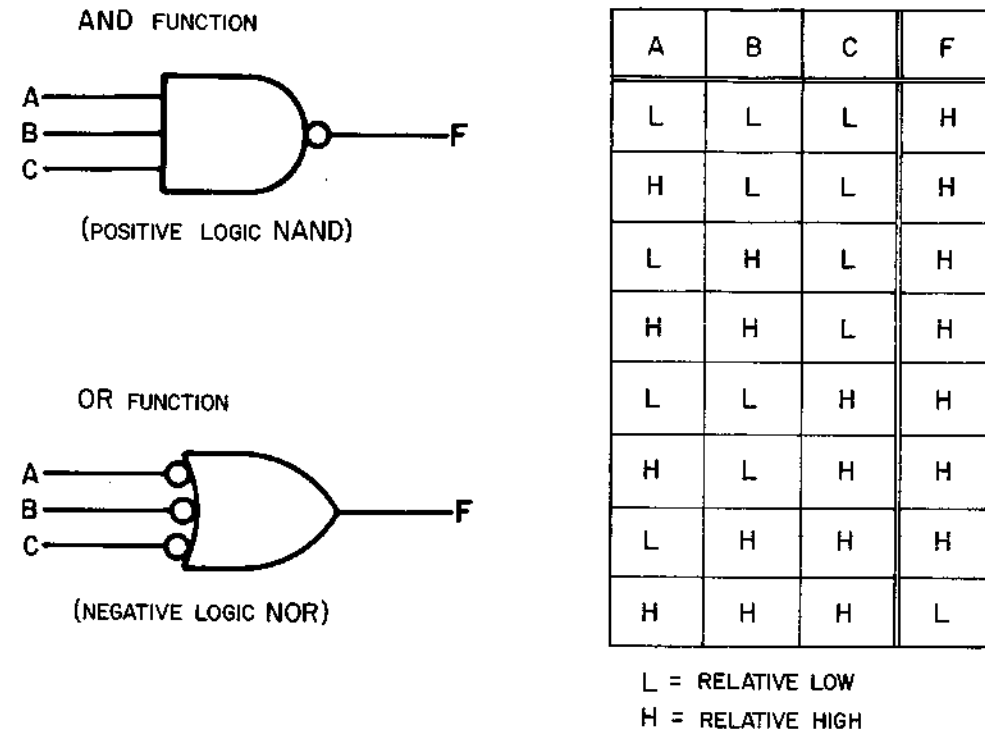

This practice runs contrary to some logic drawing standards, which require the use of the NAND symbol for both functions. But, in Diablo Systems diagrams, different symbols are used to distinguish between the two functions because the functional elements of a design are considered to be more relevant to the design theory than symbolic representation of the kinds of devices used.

This functional approach to logic symbology is basic to the logic documentation conventions employed by Diablo Systems. The conventions that govern logic symbology and signal nomenclature are explained below. Other information concerning drawing standards that may help the reader interpret Diablo Systems logic diagrams is also included.

7.2 SIGNAL NOMENCLATURE

The active level of each logic signal is assigned a descriptive name. A signal is considered active when it either causes or represents some logic event that is significant to the progress of an operation. Consequently, the name given a signal usually provides one of two kinds of functional information:

- (1) Describes the effect that signal's active level has on the logic it feeds; for example, \bar{L} oad Print Wheel Buffer is the name of the signal that clocks data into the Print Wheel Buffer.
- (2) Represents a condition or event that develops elsewhere in the logic; for example, \bar{P} rint Wheel Ready is the name of the signal that is active whenever the print wheel logic is able to accept a new print command.

A + or - sign precedes each signal name to identify which of the two voltage levels used in the logic system is considered to be that signal's active level. The + sign represents the relatively higher logic level and the - sign, the relatively lower level. This means relatively higher or lower with respect to each other; the signs do not indicate signal polarity with respect to ground.

The actual voltage levels represented by the signs will depend on the logic family being used. For example, in TTL circuits, the signal identified by \bar{P} rint Wheel Ready is active when it is at 0V (nominal) and inactive a +4V (nominal).

Sometimes a signal serves as the input to both positive logic and negative logic elements. Ordinarily in such cases, the sign preceding the signal name agrees with the active level indicated at the output of the logic element that produced the signal. An example of this is illustrated by the following sketch.

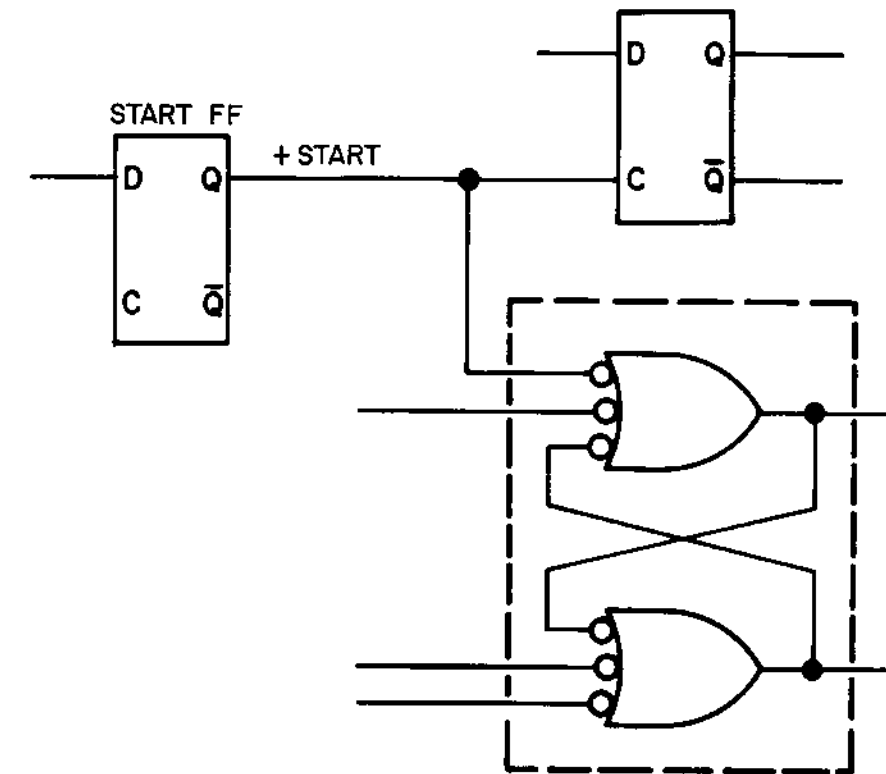

7.3 INTERPAGE REFERENCING

When a printed circuit board assembly requires more than one logic diagram page, an interpage reference scheme is used at the points on each diagram page where the signal lines enter and leave the page. The reference scheme includes the following information.

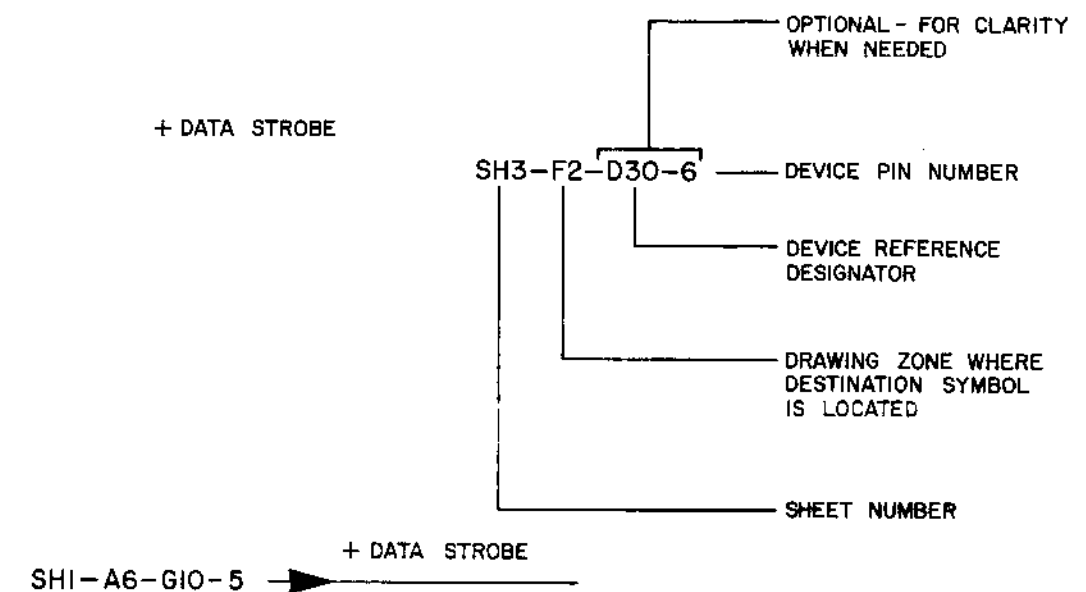

7.4 LOGIC SYMBOLOLOGY

The logic function symbols used in Diablo Systems logic diagrams conform closely to those set forth in MIL-STD-806.

Most small scale integration (SSI) circuits are represented by function symbols.

Medium scale integration (MSI) devices, such as shift registers and read-only memories, may be represented by rectangles with functional labels.

Since positive logic and negative logic conventions can both appear in a single set of logic diagrams, the unfilled circle negation symbol specified by MIL-STD-806 is used to distinguish between low-true and high-true signals.

A circle drawn at an input to a symbol indicates that that input is active at its relatively lower potential. The absence of a circle at an input means that input is logically active at its relatively higher potential. The presence or absence of a circle at a symbol output has similar meanings for the active level of that output.

Usually, all logic symbols are drawn with inputs on the left and outputs on the right. Some device symbols (e.g., one-shots, J-K flip-flops) show some inputs and other external connections on the top and/or bottom of the symbol for clarity. Also, drawing layout restriction occasionally requires that some symbols be drawn with a vertical orientation so that signal flow through them is from top to bottom. However, logic symbols are never drawn with inputs on the right or outputs on the left of the symbol; nor are they always drawn with inputs and outputs on the same side of the symbol.

The symbols used by Diablo Systems for the basic logic functions are explained below.

AND FUNCTION (WITH INVERSION) / NAND GATE

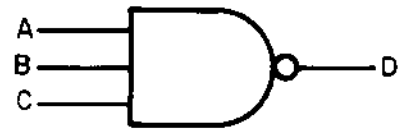

$$\bar{D} = A \cdot B \cdot C$$

Output is low (active) only if all inputs are high (active)

NOTE: \bar{D} means D is low

OR FUNCTION (WITH INVERSION) / NAND GATE



$$D = \bar{A} + \bar{B} + \bar{C}$$

Output is high (active) if any one or more inputs are low (active)

COLLECTOR OR (DOT OR)

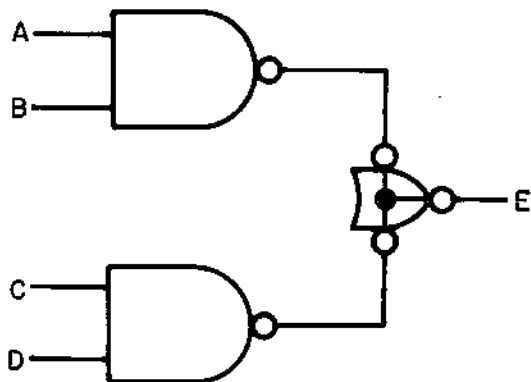

$$\bar{E} = (A \cdot B) + (C \cdot D)$$

Output of dot OR is low (active) if both inputs to either (or both) NAND gates are high (active)

NOTE: Negative logic OR function is provided by the solder junction of the two NAND gate outputs and is represented by junction dot. OR symbol represents function provided by junction.

COLLECTOR AND (DOT AND)

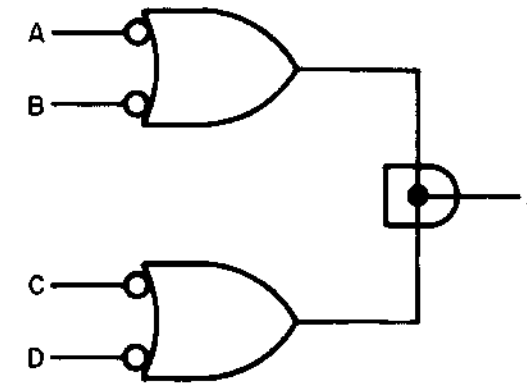

$$E = (\bar{A} + \bar{B}) \cdot (\bar{C} + \bar{D})$$

Output of dot AND is high (active) only if at least one input to each negative logic NOR gate is low (active)

NOTE: Positive logic AND function is provided by solder junction of the two negative logic NOR gate outputs and is represented by junction dot. AND symbol represents function provided by junction.

R/S FLIP-FLOP

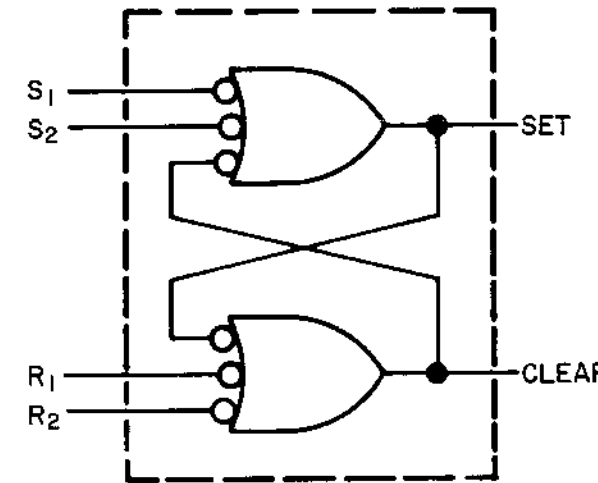

$$\text{SET OUT } (\bar{S}_1 + \bar{S}_2) (R_1 R_2)$$

$$\text{CLEAR OUT } (S_1 S_2) (\bar{R}_1 + \bar{R}_2)$$

Flip-flop is considered set (SET output is high and CLEAR output is low) when at least one "S" input is low and both "R" inputs are high. Flip-flop is considered reset (SET output is low) when both "S" inputs are high and at least one "R" input is low.

When all inputs are high, flip-flop remains in last state.

A low applied to both an "S" input and an "R" input will make both outputs high. Flip-flop will remain in state of last input removed.

NOTE: This function is provided by cross-coupling the outputs of a pair of negative logic NOR gates. Any low "S" will SET flip-flop (SET high/clear low). Any low "R" will RESET flip-flop (SET low/clear high).

20600-XX

20600-XX D2

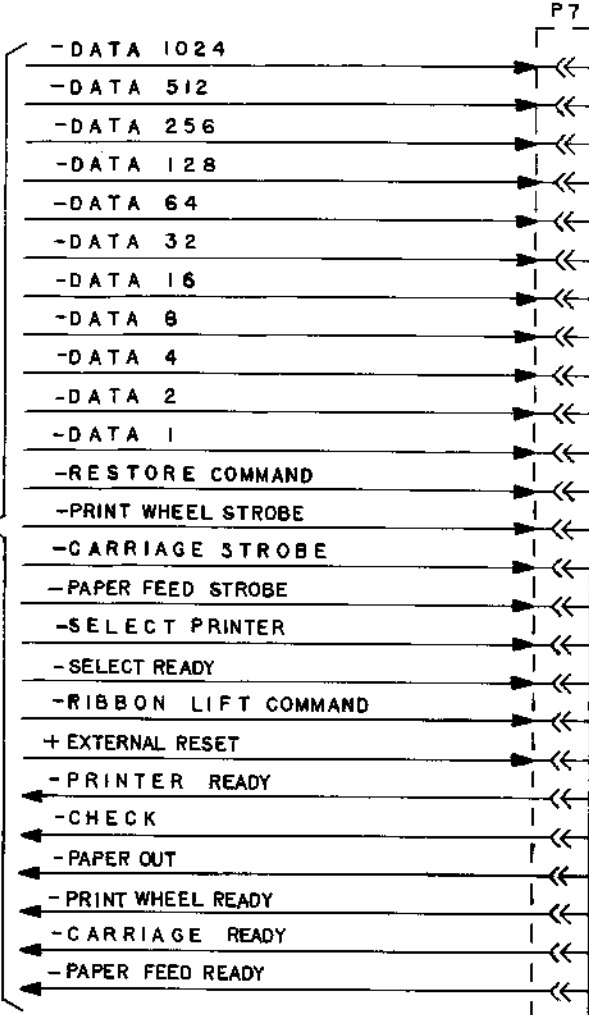

NOTE:
THIS SCHEMATIC COVERS THE INTERCONNECTS FOR BASIC ASSEMBLIES 20600-00 AND 20600-01 (SERIES I200, HYTYPE I).

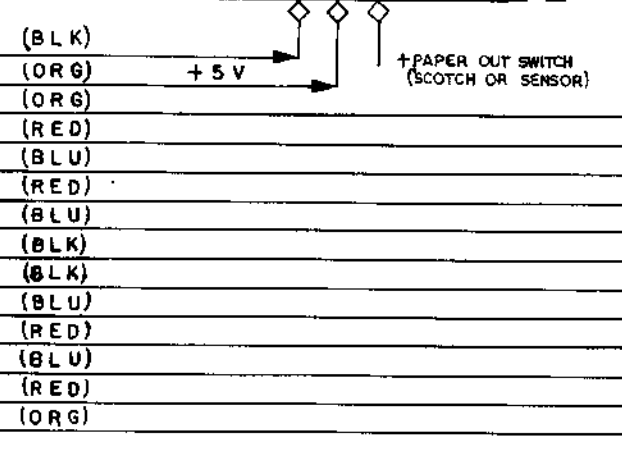
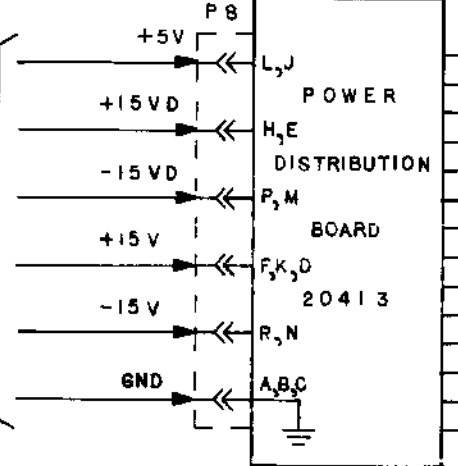
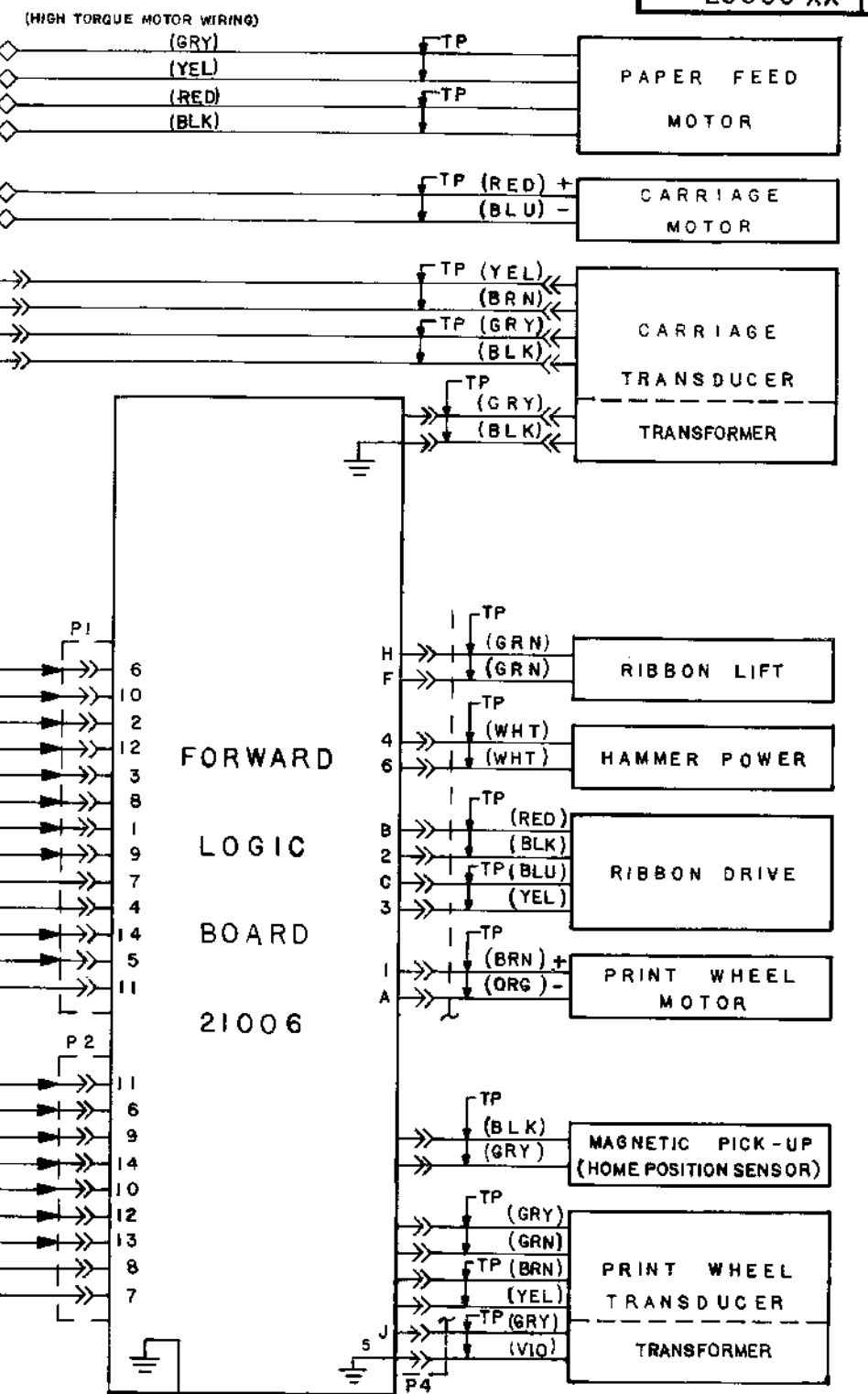
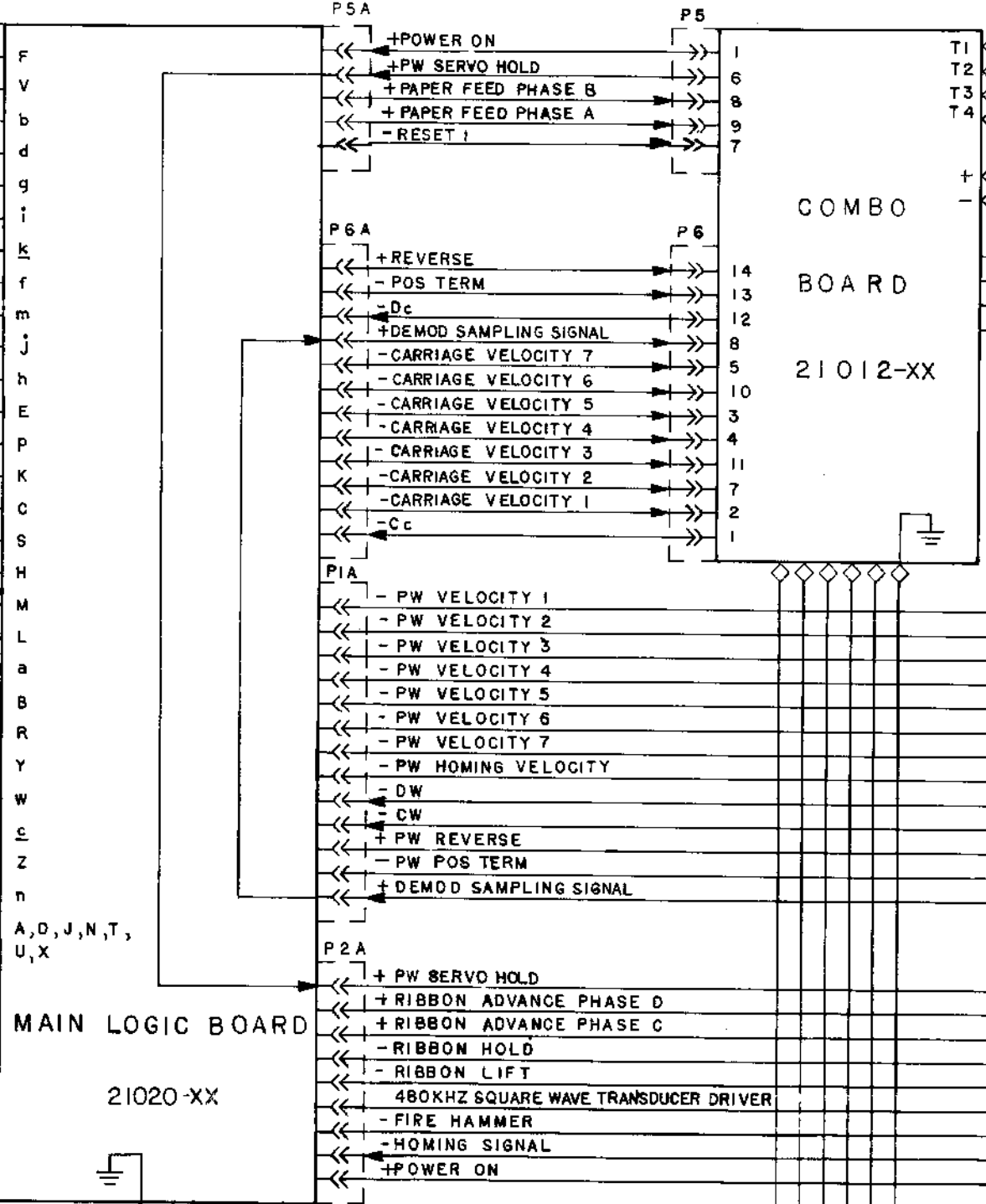
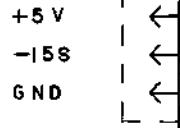

Diablo Systems Incorporated
Hayward, California 94545

TITLE: PRINTER ASSY - SCHEMATIC

MODEL: I200 HYTYPE I

PROPERTY OF DIABLO SYSTEMS INCORPORATED. UNAUTHORIZED REPRODUCTION OR USE PROHIBITED.

DATE: 10/74

DATE CHECKED: 10/74

DATE DRAWN: 10/74

DATE: 10/74

PRODUCT NO: 20600-XX

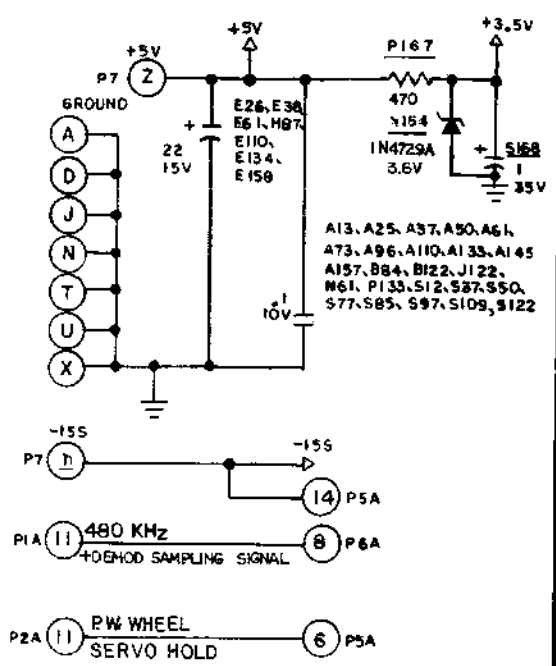
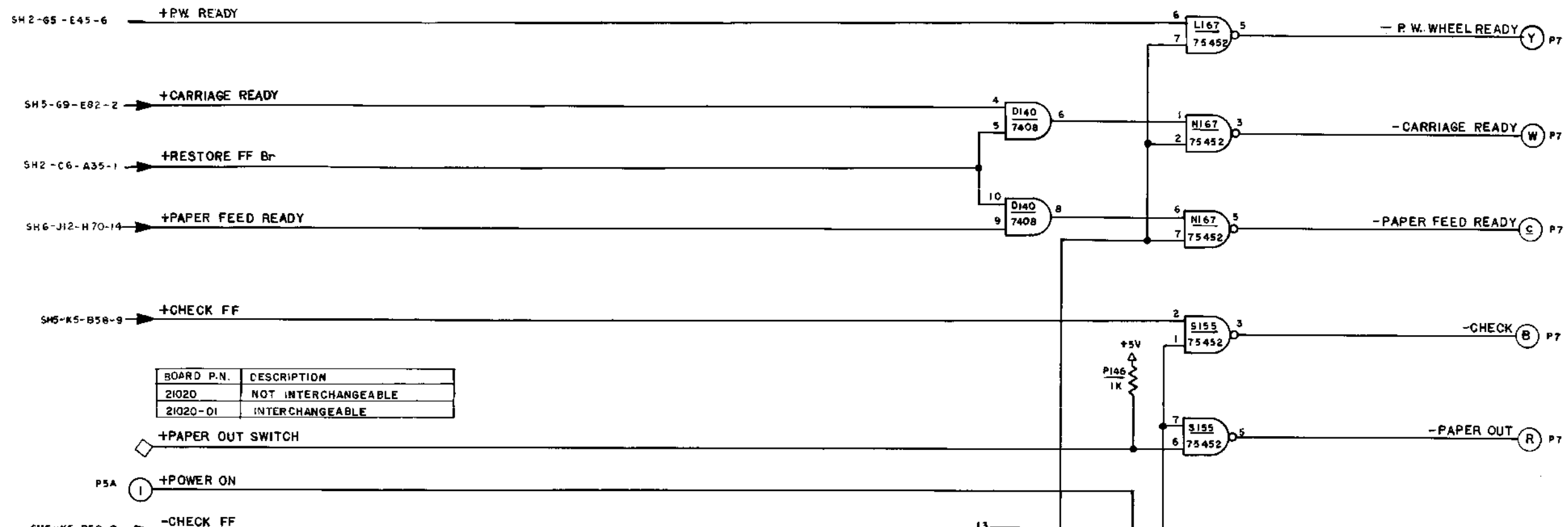

NOTES: UNLESS OTHERWISE SPECIFIED

- P7 IS INTERFACE CONNECTOR.
- P1 & P2 INTERCONNECT TO FORWARD BOARD.
- P5 & P6 INTERCONNECT TO COMBO BOARD.
- RESISTORS ARE 1/4W, 5%. ALL 1% RESISTORS ARE 1/8W.
- ALL DIODES ARE 1N4454.
- ALL RESISTORS IN OHMS.
- ALL CAPACITORS IN μ F.

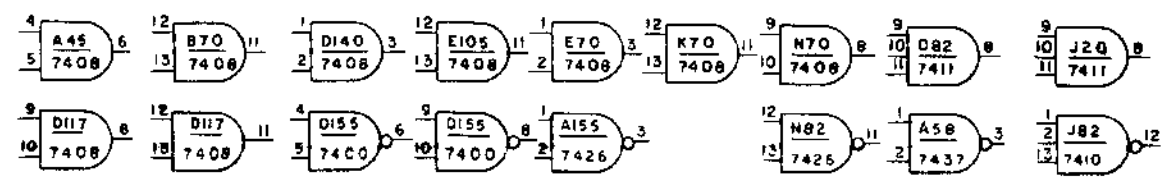
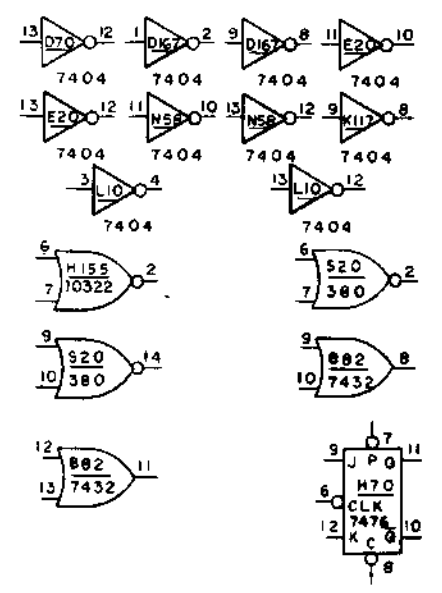
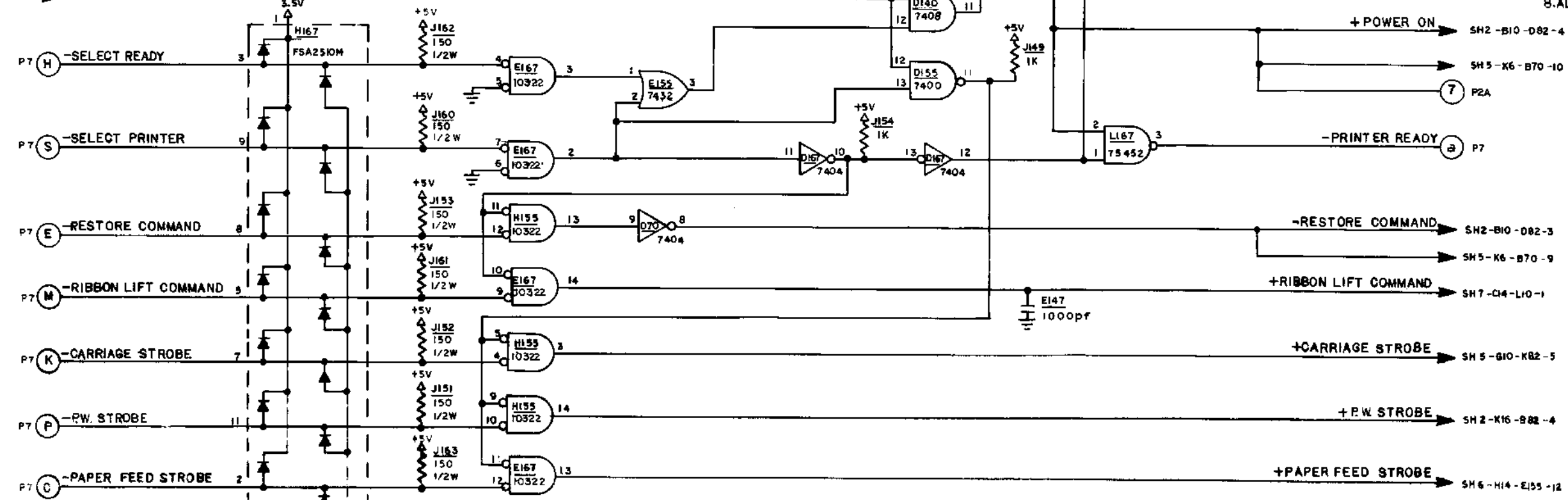

Diablo Systems Incorporated
Hayward, California 94545

MAIN LOGIC BOARD INTERFACE
MODEL: 1200 HYTYPE I

DATE: 1/1/74
DRAWN: []
CHECKED: []
DATE: []

PRODUCT NO. 21020-XX

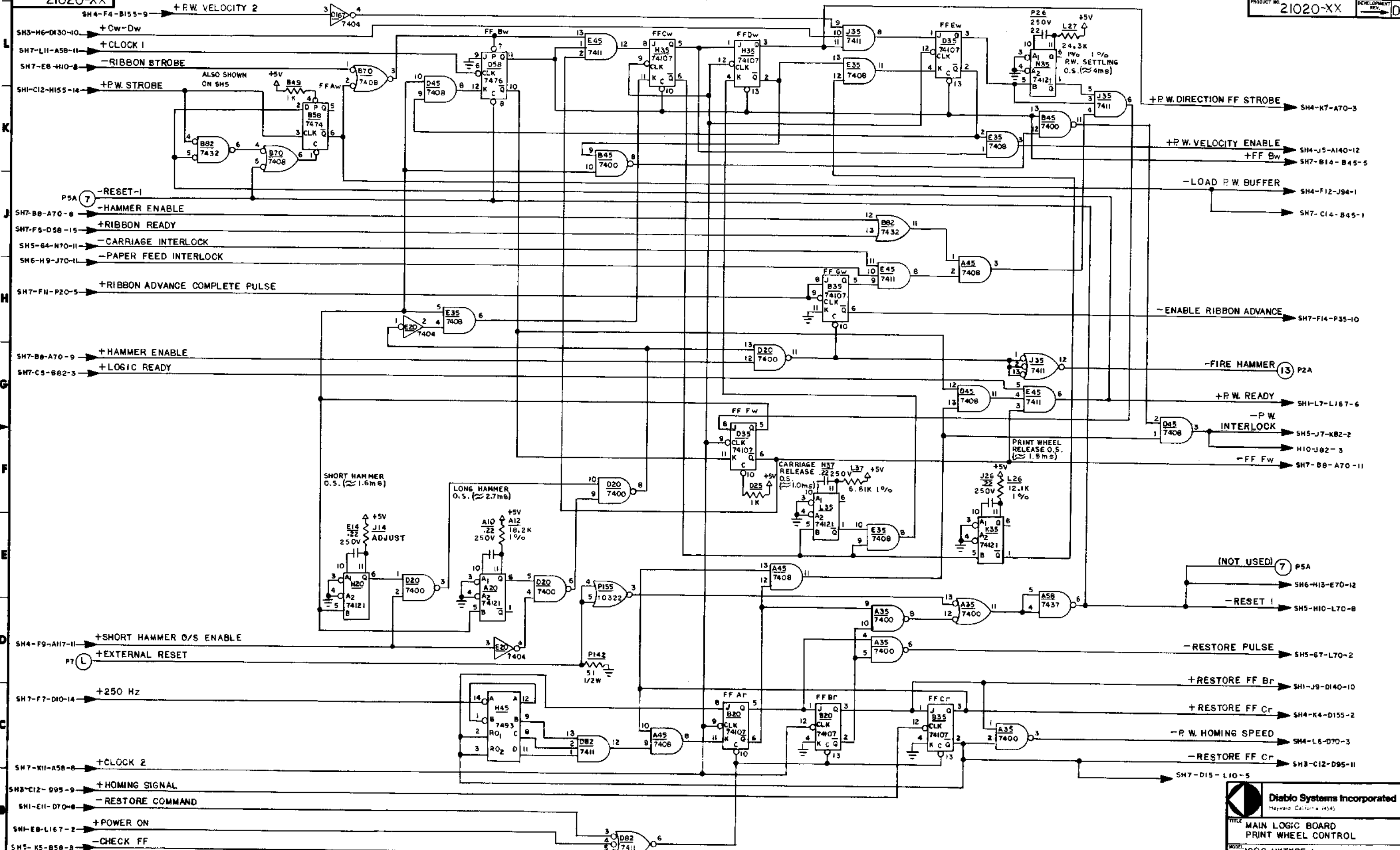

Diablo Systems Incorporated
Hayward, California 94545

TITLE: **MAIN LOGIC BOARD**
PRINT WHEEL CONTROL

MODEL: **1200 HYTYPE I**

PROPERTY INFORMATION: UNAUTHORIZED DISCLOSURE OR USE PROHIBITED.

REV. E.C.D. NO.	REV. E.C.D. NO.	REV. E.C.D. NO.	REV. E.C.D. NO.	REV. E.C.D. NO.	REV. E.C.D. NO.	REV. E.C.D. NO.	REV. E.C.D. NO.	REV. E.C.D. NO.	REV. E.C.D. NO.	REV. E.C.D. NO.	REV. E.C.D. NO.	REV. E.C.D. NO.	REV. E.C.D. NO.	REV. E.C.D. NO.	REV. E.C.D. NO.	REV. E.C.D. NO.	REV. E.C.D. NO.	REV. E.C.D. NO.	REV. E.C.D. NO.	REV. E.C.D. NO.
Q 505B	P 3983	N 3895	M 3799	L 3727	K 3626	J 3596	H 3525	G 3467	F 2763	E 2738	D 2479	C 2476	B 2401	A 2050	DATE	DATE	DATE	DATE	DATE	DATE

DATE: 2 10 1974

SHEET TOTAL: 2 SHEETS

PRODUCT NO. 21020-XX

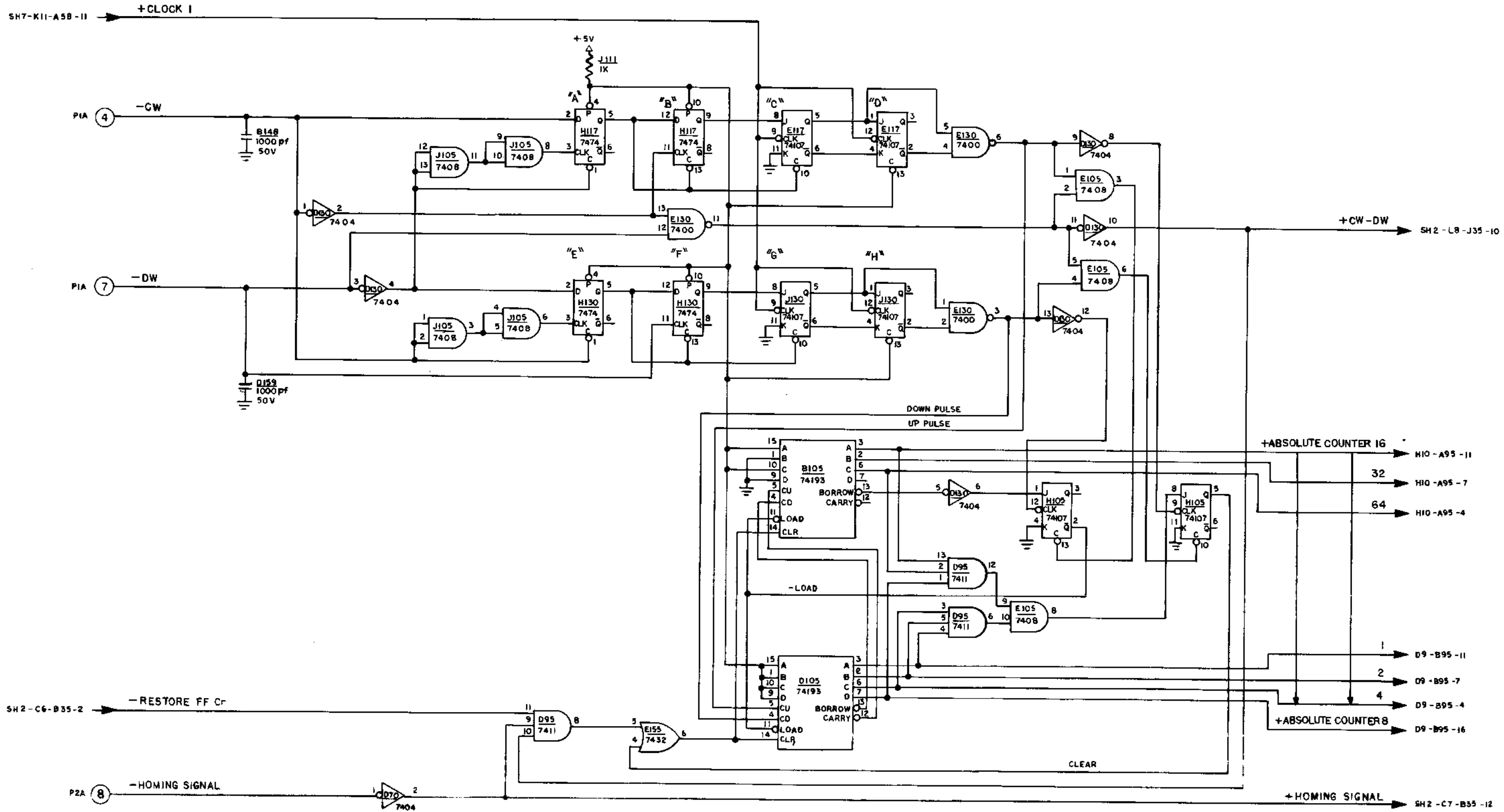

Diablo Systems Incorporated
 Hayward, California 94545

TITLE
MAIN LOGIC BOARD
 P.W. ABSOLUTE COUNTER

MODEL
 1200 HYTYPE I

PROPRIETARY INFORMATION - SYSTEM LOGIC NO.
 UNAUTHORIZED DISCLOSURE
 OR USE PROHIBITED

PRODUCT NO	21020-XX
REFERENCE DESIGNATORS NOT USED	
REFERENCE DESIGNATORS LAST USED	
REV. E.C.O. NO.	Q 5058
REV. E.C.O. NO.	P 3983
REV. E.C.O. NO.	N 3895
REV. E.C.O. NO.	M 3799
REV. E.C.O. NO.	L 3727
REV. E.C.O. NO.	K 3626
REV. E.C.O. NO.	J 3596
REV. E.C.O. NO.	H 3525
REV. E.C.O. NO.	G 3467
REV. E.C.O. NO.	F 2763
REV. E.C.O. NO.	E 2738
REV. E.C.O. NO.	D 2479
REV. E.C.O. NO.	C 2476
REV. E.C.O. NO.	B 2401
REV. E.C.O. NO.	A 2050
DATE	
DATE	
DATE	
DATE	
DATE	
SHEET	3
TOTAL SHEETS	D
PRODUCT NO	21020-XX
REV.	QA

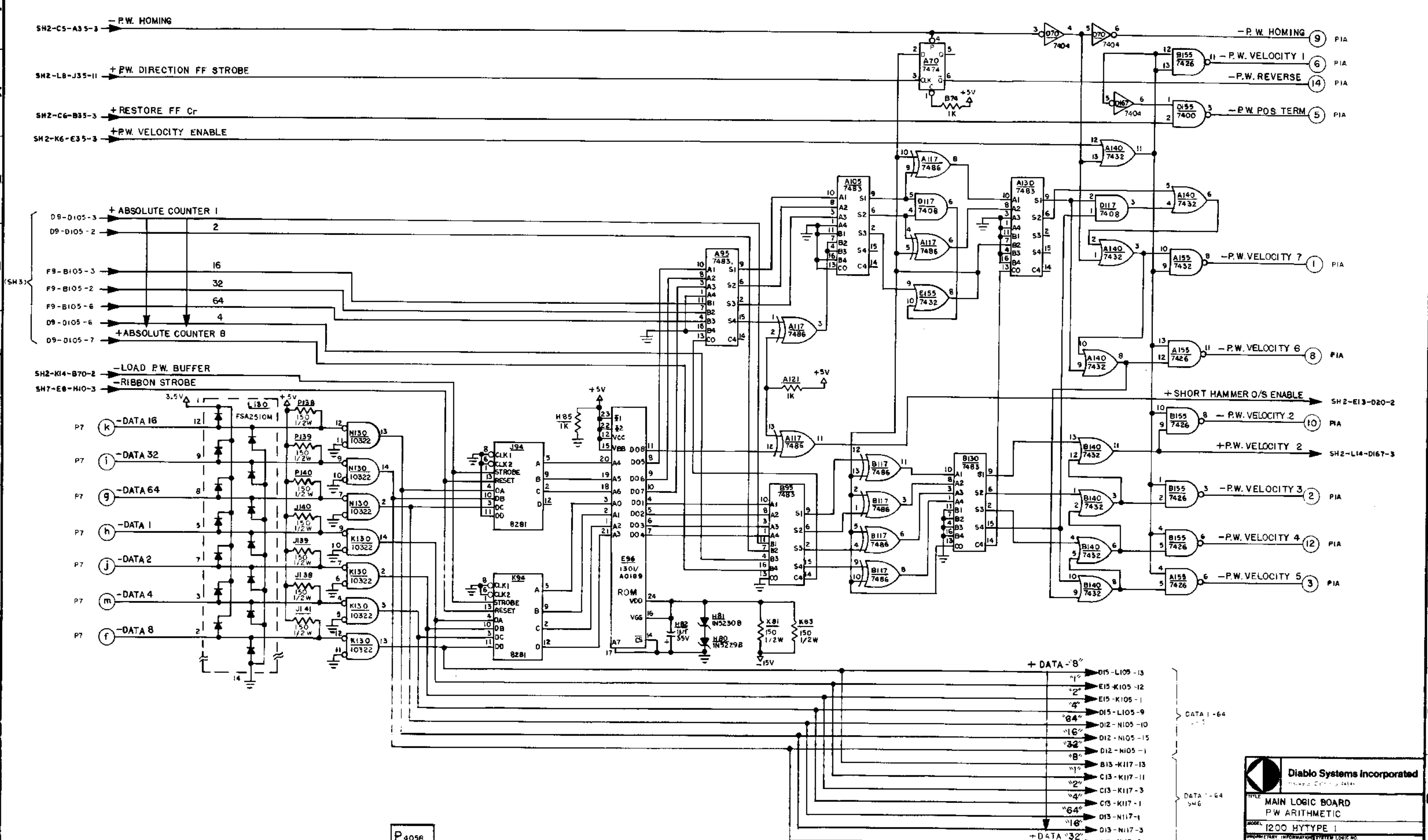

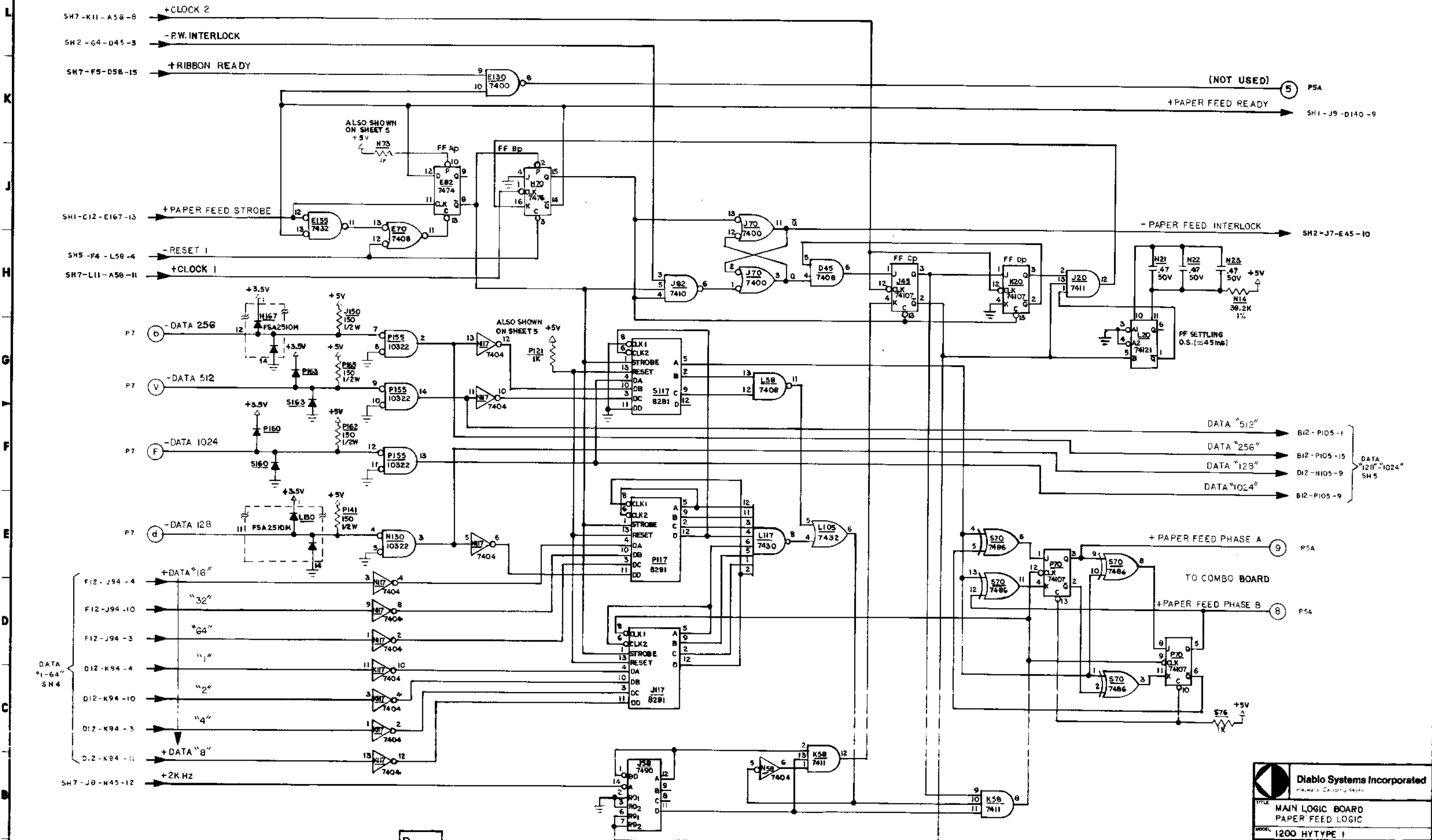

Diablo Systems Incorporated Folsom, California 94601	
TITLE MAIN LOGIC BOARD PAPER FEED LOGIC	
MODEL 1200 HYTYPE I	
UNAUTHORIZED DISCLOSURE OR USE PROHIBITED	
DATE ENG DATE CHECKED DATE DRAWN DATE	
SHEET TOTAL SHEETS SIZE	
PRODUCT NO. 21020-XX NY	

PRODUCT NO. 21020-XX	REFERENCE DESIGNATORS NOT USED	REFERENCE DESIGNATORS LAST USED	P4059	Q5058	P3983	N3895	M3799	L3727	K3626	J3595	H3525	G3467	F2763	E2738	D2479	C2476	B2401	A2050	DATE	ENG	DATE	CHECKED	DATE	DRAWN	DATE
-----------------------------	--------------------------------	---------------------------------	--------------	--------------	--------------	--------------	--------------	--------------	--------------	--------------	--------------	--------------	--------------	--------------	--------------	--------------	--------------	--------------	------	-----	------	---------	------	-------	------

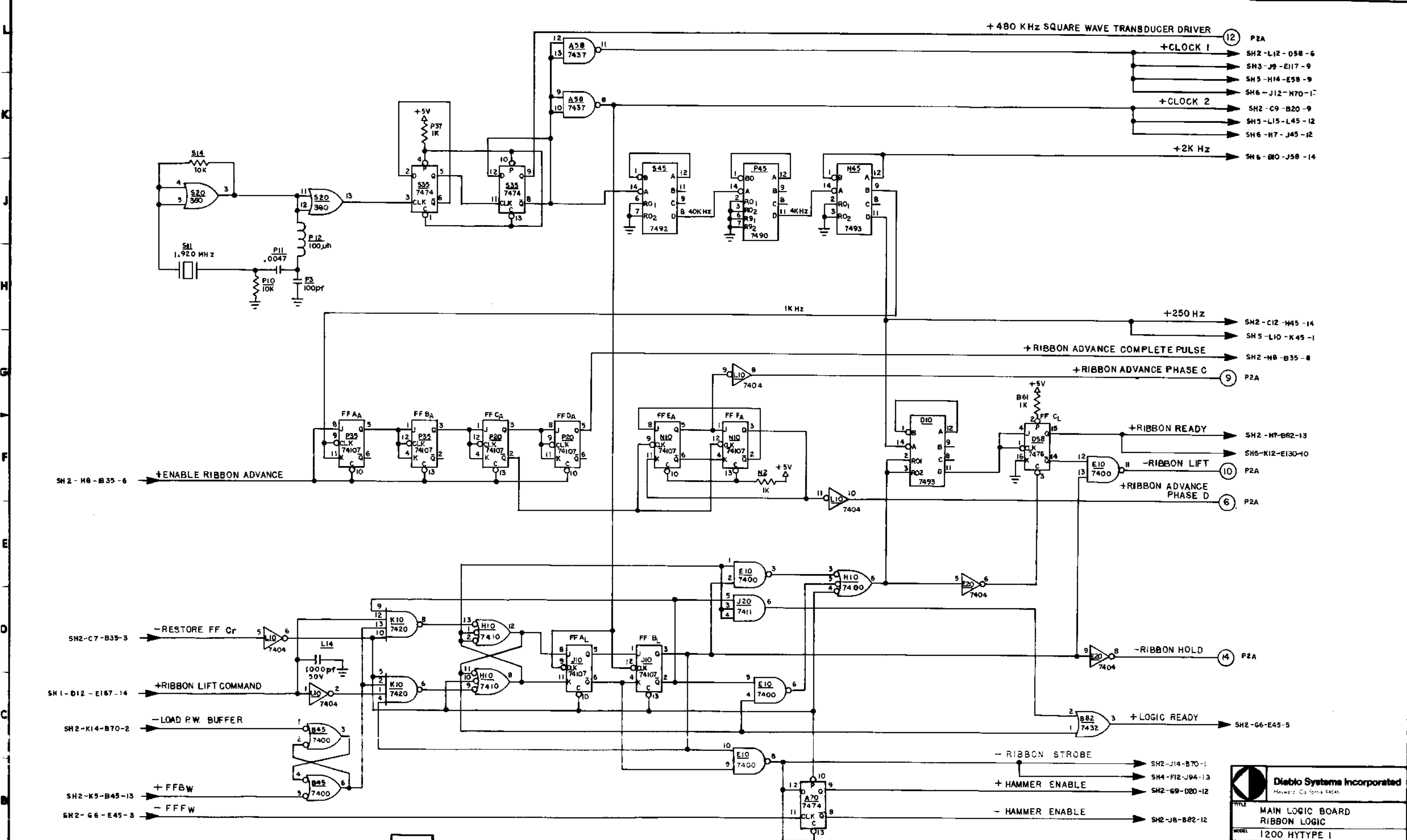

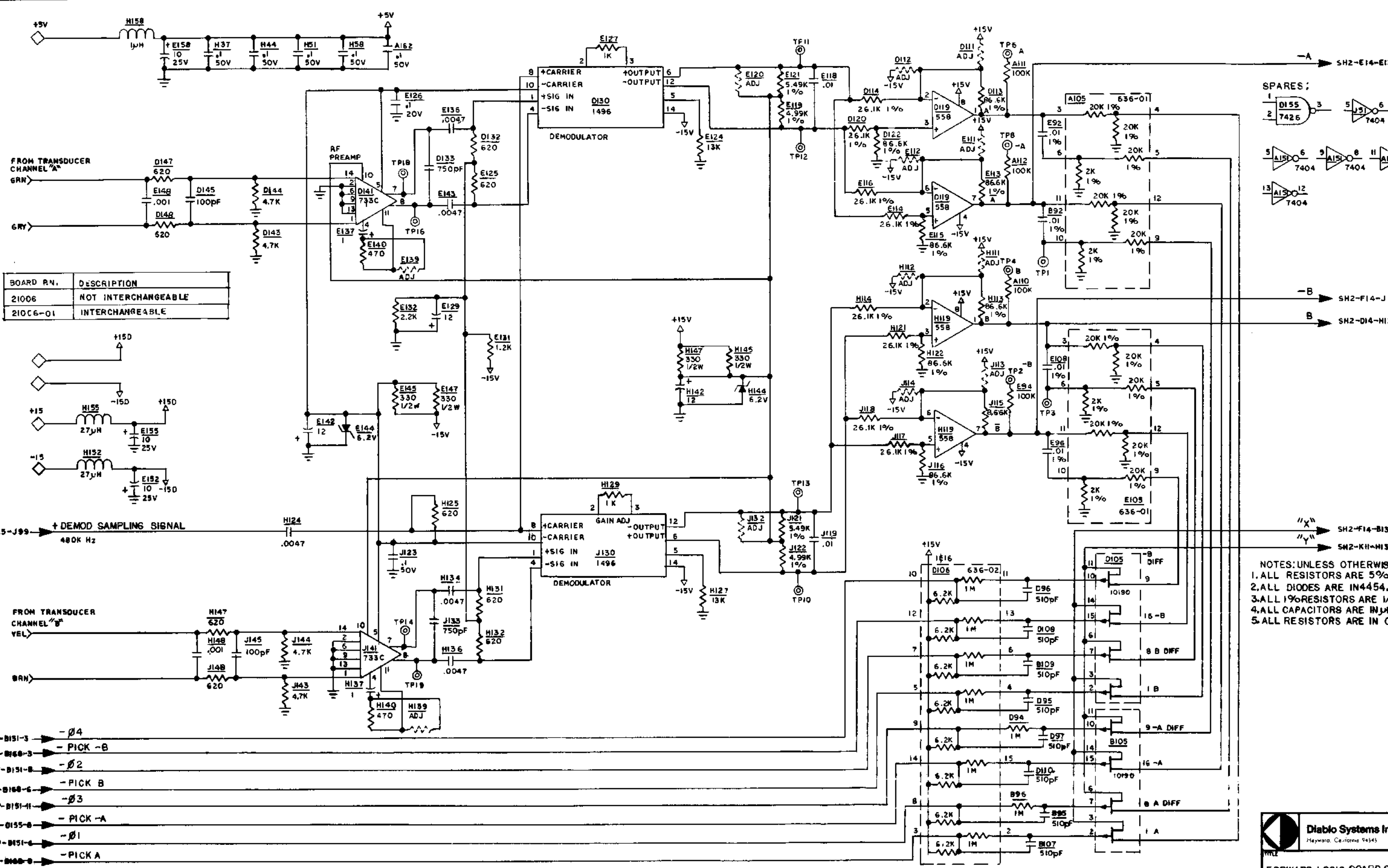

BOARD P.N.	DESCRIPTION
21006	NOT INTERCHANGEABLE
21006-01	INTERCHANGEABLE

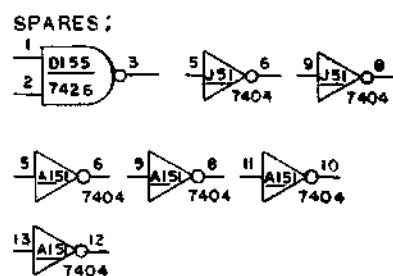

NOTES: UNLESS OTHERWISE SPECIFIED
 1. ALL RESISTORS ARE 5% 1/4W.
 2. ALL DIODES ARE IN4454.
 3. ALL 1% RESISTORS ARE 1/8W.
 4. ALL CAPACITORS ARE IN JF.
 5. ALL RESISTORS ARE IN OHMS.

- SH2-D7-B151-3 → -β4
- SH2-D6-B160-3 → - PICK -B
- SH2-E7-B151-8 → -β2
- SH2-D6-B160-6 → - PICK B
- SH2-E7-B151-11 → -β3
- SH2-C6-D155-8 → - PICK -A
- SH2-F7-B151-6 → -β1
- SH2-D7-B160-9 → - PICK A

K 4173
 K 3913

Diablo Systems Incorporated
 Hayward, California 94545

FORWARD LOGIC BOARD SCHEMATIC
 1200E1210 HYTYPE I

DATE DWG DATE CHECKED DATE DRAWN

PRODUCT NO. 21006-XX

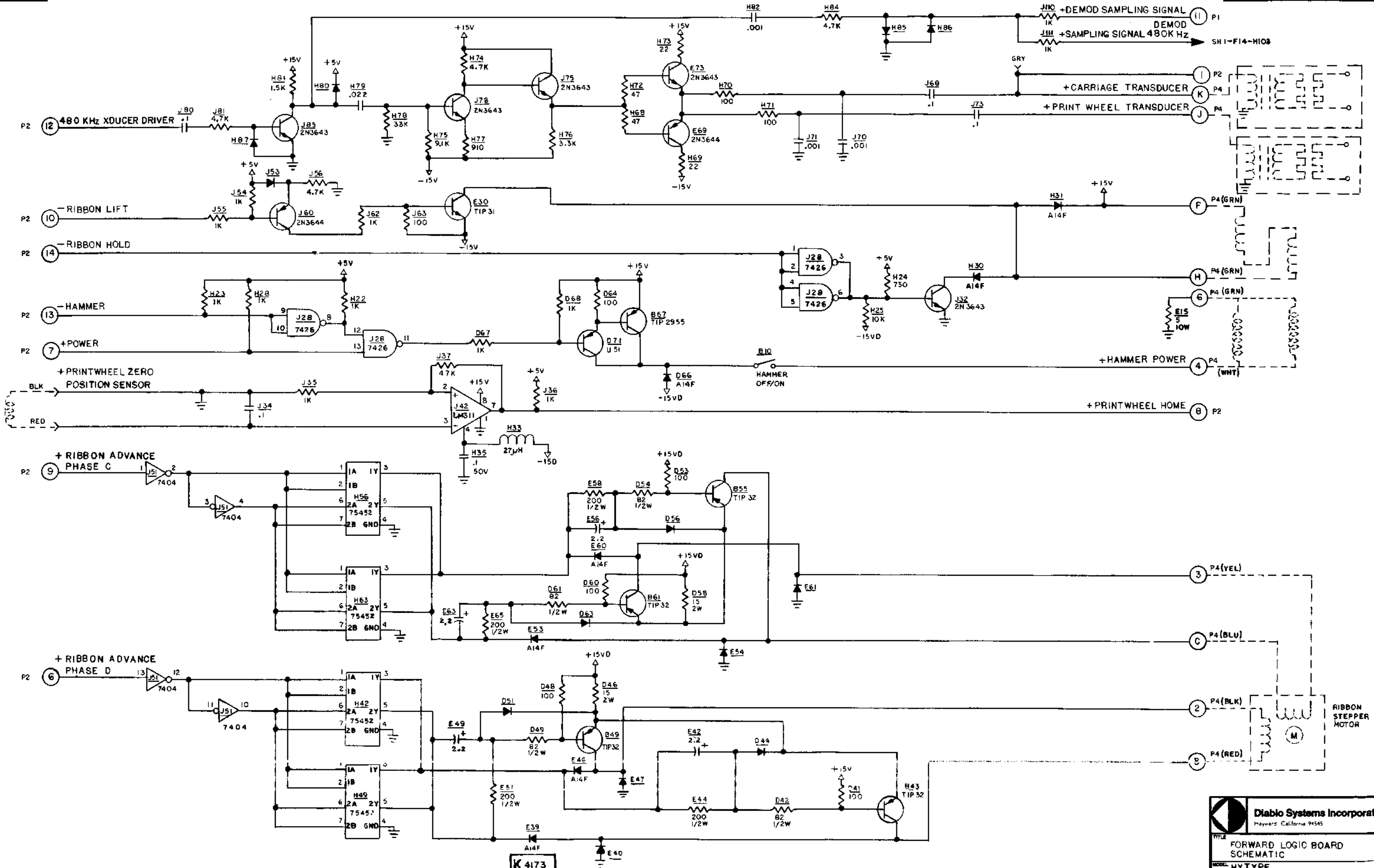

Diablo Systems Incorporated
 Hayward, California 94545

TITLE: FORWARD LOGIC BOARD SCHEMATIC
 MODEL: HYTYPE

PROPRIETARY INFORMATION - SYSTEM LOGIC IS UNAUTHORIZED DISCLOSURE OR USE PROHIBITED.

SHEET TOTAL SHEETS: 3 OF 3

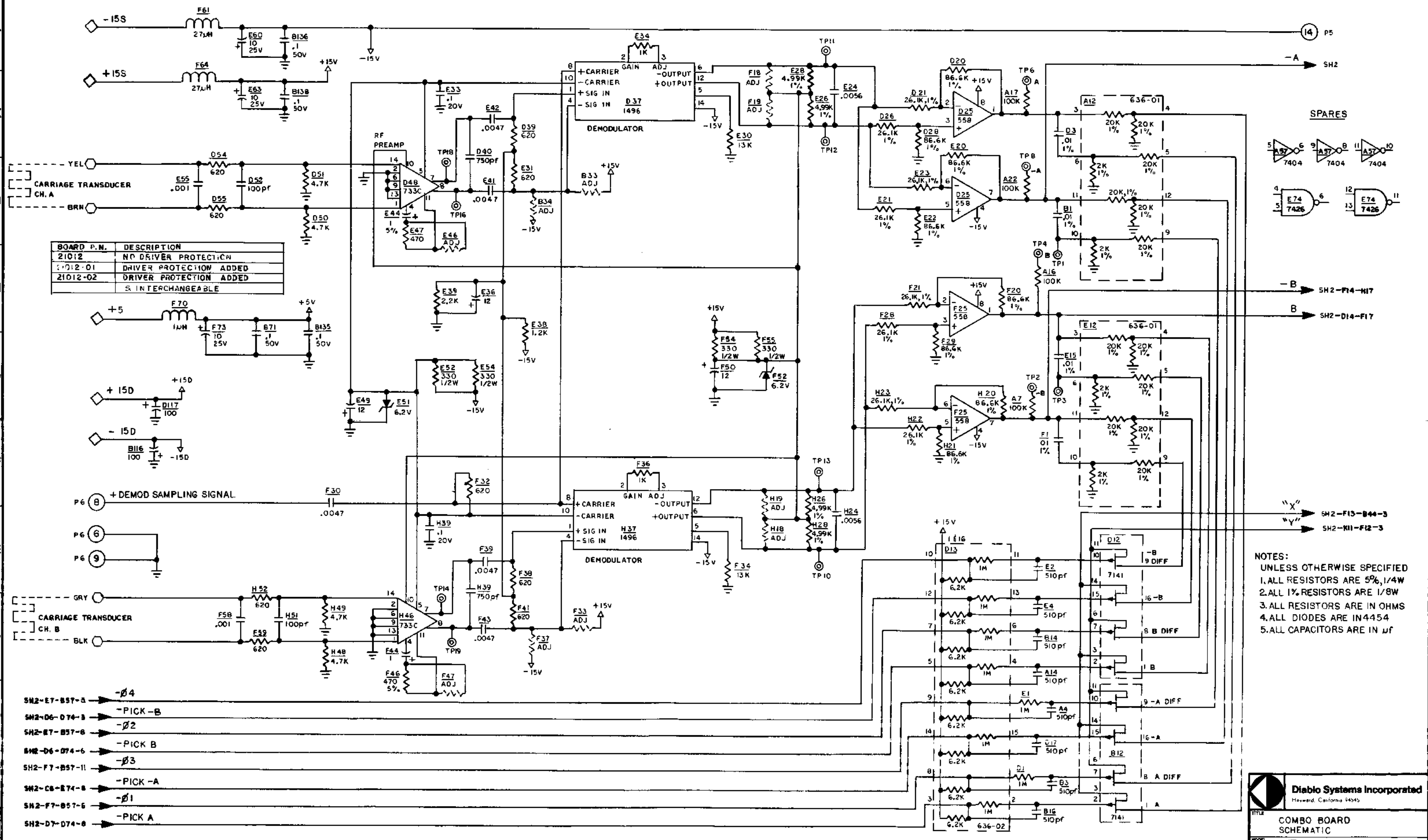

BOARD P.N.	DESCRIPTION
21012	NO DRIVER PROTECTION
21012-01	DRIVER PROTECTION ADDED
21012-02	DRIVER PROTECTION ADDED
	S INTERCHANGEABLE

- NOTES:
 1. ALL RESISTORS ARE 5%, 1/4W
 2. ALL 1% RESISTORS ARE 1/8W
 3. ALL RESISTORS ARE IN OHMS
 4. ALL DIODES ARE IN 4454
 5. ALL CAPACITORS ARE IN μ F

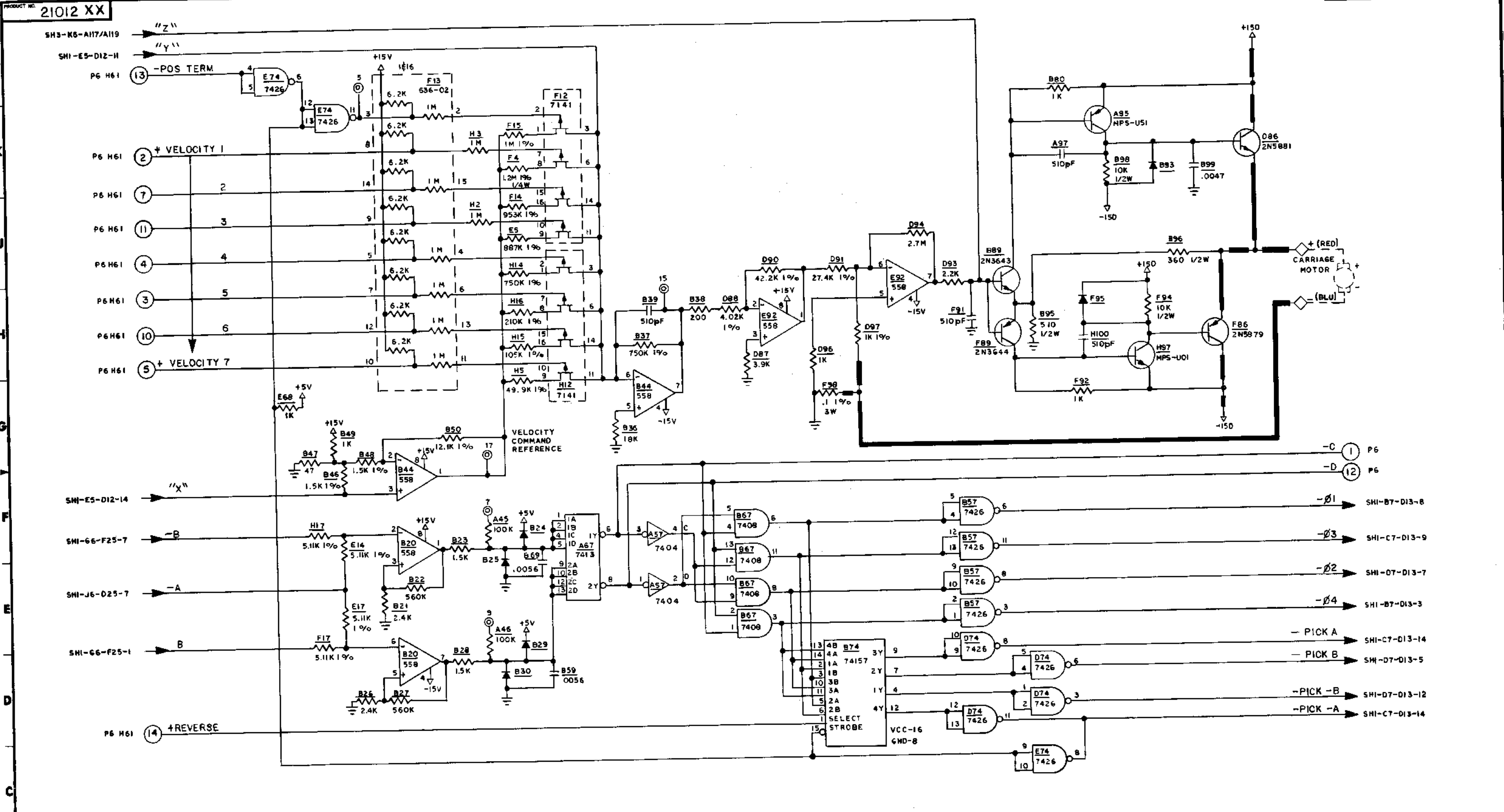

Diablo Systems Incorporated
 Hayward, California 94545

TITLE: **COMBO BOARD SCHEMATIC**

MODEL: **1200/1210 HYTYPE I**

UNAUTHORIZED DISCUSSURE OR USE PROHIBITED

SHEET 2 TOTAL SHEETS 302 PRODUCT NO. 21012-XX

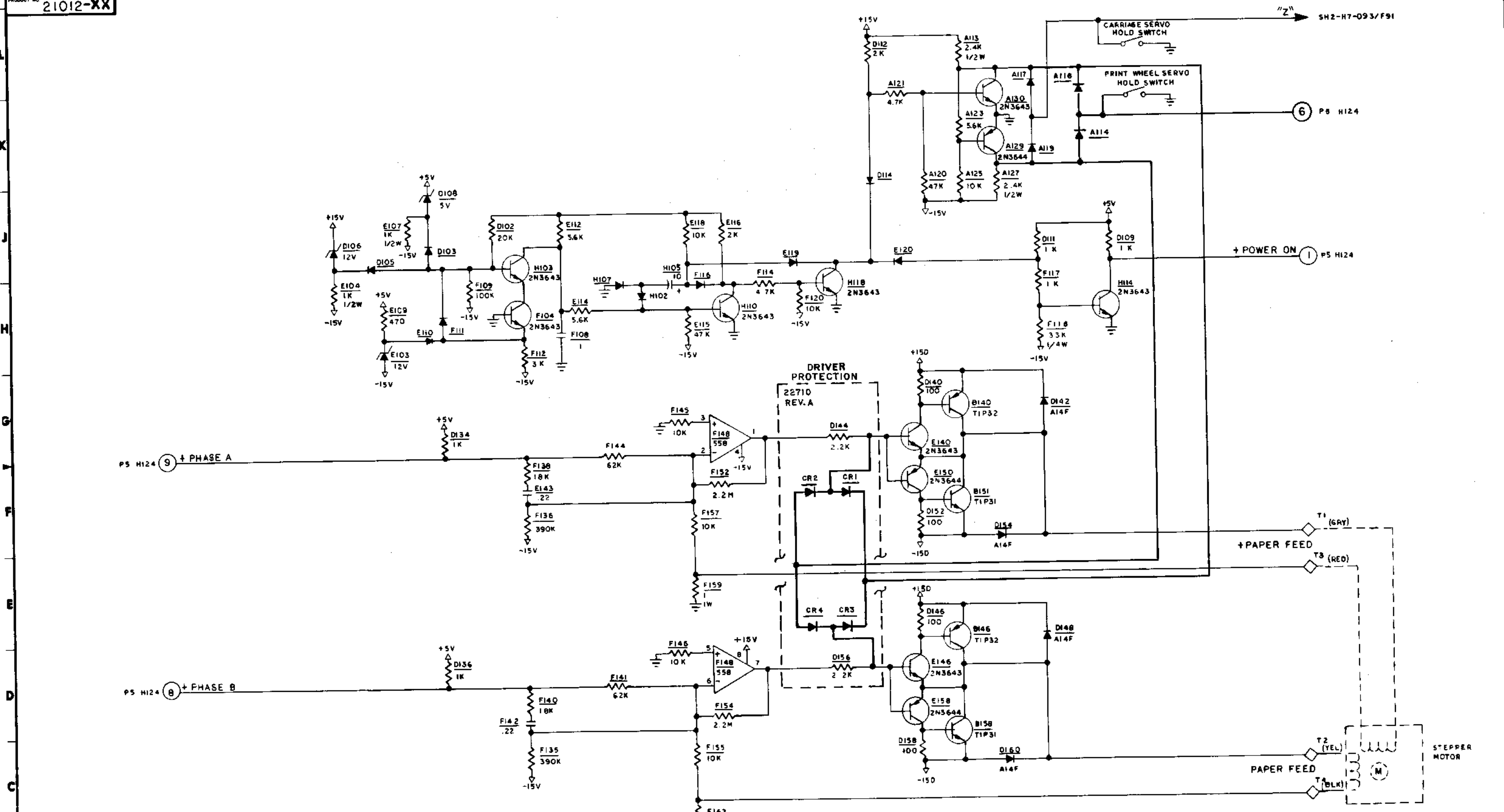

Diablo Systems Incorporated
 TITLE: COMBO BOARD SCHEMATIC
 MODEL: 1200 & 1210 HYTYPE I
 SHEET TOTAL SHEETS: 3

REV. EGG NO.	REV. EGG NO.	REV. EGG NO.	REV. EGG NO.	REV. EGG NO.	REV. EGG NO.	REV. EGG NO.	REV. EGG NO.	REV. EGG NO.	REV. EGG NO.	DATE	CHK	DATE	CHECKED	DATE	DRAWN	DATE	DATE	DATE
J3913	J3809	H3762	G3596	F2710	E2384	D2384	C2359	B2240	A2165									