



TECHNICAL MANUAL

RS232C - TAPE PERIPHERAL INTERFACE

MODELS: RJA2322-B/RJA2321-B/RJR2321-B

**Peripheral
Products**

Ex-Cell-O Corporation

TECHNICAL MANUAL
RS232C - TAPE PERIPHERAL INTERFACE
MODELS: RJA2322-B/RJA2321-B/RJR2321-B

IMPORTANT INFORMATION

Changes to the equipment which are made between manual printings are listed in an addendum at the rear of the manual. As a convenience, a list of change pages is given as the last page in the manual. It is recommended that each of these pages be marked "Refer to Addendum" so that these changes can be identified.

EX-CELL-O CORPORATION
REMEX
1733 Alton St. • P.O. Box C-19533 • Irvine, CA 92713

Copyright © 1978 by REMEX, A Unit of Ex-Cell-O Corporation. Printed in the United States of America. All rights reserved. This book or parts thereof may not be reproduced in any form without permission of the publishers.

WARRANTY

The following section is part of the Standard Terms and Conditions and covers only the Warranty. The reader should refer to the complete Standard Terms and Conditions for the entire sales agreement.

The Seller warrants to the original Buyer only, that the Product, except as to software and firmware, is free from defects in workmanship and material under normal use and service. The Seller's obligation under this warranty shall be limited to furnishing a replacement for, or at the Seller's option repairing any Product or any part or parts thereof, which prove defective within 90 days* from the date of shipment by the Seller, provided such Product or such part or parts are returned to the Seller transportation prepaid.

The Seller warrants, for a period of thirty (30) days from the date of shipment by the Seller to the original Buyer only, that the software and firmware Products are free from defects in workmanship and material. Seller's obligation under this warranty shall be limited to correcting any of said defects or replacing the software or firmware. Said warranty shall be void and of no effect whatsoever in the event that changes or additions have been made to the software or firmware (or in the event that the software or firmware product has been adapted by the Buyer) to serve a function not within the system specifications of the Seller.

All replacement Products or parts thereof furnished under this warranty will be invoiced in the usual manner and adjustments will be made after the Product or part thereof claimed to be defective has been returned to, and inspected at, the Seller's plant. Replacements shall be furnished under this warranty F.O.B. Buyer's plant, and the Seller shall not be responsible for installation costs. (For all international transactions, replacement shall be furnished F.O.B. Port of Entry and Buyer is responsible for all customs and brokerage fees.) The Buyer shall be liable for all freight inspection and handling costs if such Product or such part or parts do not prove to be defective. In no event will any claim for labor in removing or replacing a defective Product or part for incidental or consequential damages be allowed. No warranty is made as to any Product or part which has not been installed, operated, or maintained in accordance with Seller's instructions or the instructions contained in its operations or maintenance manuals, when furnished by the Seller, or which has been subject to misuse, abuse, accident, or alteration or to improper or negligent use, maintenance, storage, transportation or handling.

This warranty is in lieu of all other warranties expresses or implied, including any warranty of merchantability or fitness for a particular purpose, and the Seller neither assumes, nor authorizes any person or firm to assume for it, any other or further obligation or liability in connection with the sales, installation or use of any product.

UNDER NO CIRCUMSTANCES SHALL SELLER OR ANY AFFILIATE OF SELLER HAVE ANY LIABILITY WHATSOEVER FOR LOSS OF USE OR FOR ANY INDIRECT, INCIDENTAL OR CONSEQUENTIAL DAMAGES.

*All paper tape products are covered under this warranty for a period of one year, excepting punch mechanisms, lamps and fuses which are warranted for a period of 90 days. Flexible disk drives are warranted for a period of 180 days.

FOR YOUR SAFETY

Before undertaking any maintenance procedure, whether it be a specific troubleshooting or maintenance procedure described herein or an exploratory procedure aimed at determining whether there has been a malfunction, read the applicable section of this manual and note carefully the

WARNING

and

CAUTION

contained therein.

The equipment described in this manual contains voltages hazardous to human life and safety and may contain mechanical components capable of inflicting personal injury. The cautionary and warning notes are included in this manual to alert operator and maintenance personnel to the electrical and mechanical hazards and thus prevent personal injury and damage to equipment.

TABLE OF CONTENTS

Section	Title	Page
I	GENERAL DESCRIPTION	1-1
1.1	EQUIPMENT DESCRIPTION	1-1
1.2	EQUIPMENT SUPPLIED.	1-1
1.3	EQUIPMENT WARRANTY	1-3
1.4	MAINTENANCE EQUIPMENT REQUIRED BUT NOT SUPPLIED.	1-3
1.5	SPECIFICATIONS	1-3
1.6	MODEL NUMBER DESIGNATION	1-3
1.7	PHYSICAL DESCRIPTION	1-7
II	INSTALLATION.	2-1
2.1	UNPACKING	2-1
2.2	SYSTEM MOUNTING	2-1
2.3	INITIAL ADJUSTMENTS	2-1
2.4	POWER AND SYSTEM CONNECTIONS	2-3
2.5	INTERFACE CIRCUITRY	2-3
III	OPERATION.	3-1
3.1	INPUT-OUTPUT SIGNALS	3-1
3.2	CONTROL FUNCTIONS	3-1
3.3	OPERATING INSTRUCTIONS	3-1
3.3.1	MODES OF OPERATION	3-1
3.3.2	OPERATING PROCEDURE	3-5
3.4	REMOTE CONTROL SIGNALS	3-7
3.5	ADDITIONAL APPLICATIONS	3-7
3.5.1	REMOTE MODE READER/PUNCH START/STOP	3-7
3.5.2	REMOTE MODE -READER SINGLE STEP-ASCII-DC1	3-9
3.5.3	REMOTE MODE-PROGRAMMABLE READER STOP	3-9
3.5.4	LOCAL MODE-PROGRAMMABLE READER DELAY	3-10
3.5.5	LOCAL MODE READER SINGLE STEP (PICK INPUT)	3-10
3.5.6	LOCAL OR REMOTE MODE-CLEAR TO SEND (CTS)	3-10
	START/STOP	

TABLE OF CONTENTS
(CONTINUED)

Section	Title	Page
3.5.7	LOCAL MODE -PUNCH START STOP	3-10
3.6	TYPICAL CONFIGURATIONS OF HOOKUP	3-11
3.6.1	MODEM PORT-RS-232-C	3-11
3.6.2	TERMINAL PORT-RS-232-C	3-11
3.6.3	MODEM AND TERMINAL PORT	3-11
3.6.4	CURRENT LOOP OPERATION	3-11
3.6.4.1	Current Loop Modification to External (Loop Source)	3-12
3.6.4.2	Current Loop Modification to 60mA	3-12
3.7	SPECIAL FEATURES	3-12
3.7.1	ECHO FEATURE	3-12
3.7.2	READER INTERCHARACTER DELAY	3-12
3.8	SPECIAL CAUTIONS	3-13
3.8.1	"X ON" AND "X OFF" TERMINOLOGY	3-13
3.8.2	CHARACTER BUFFERING READER	3-13
IV	THEORY OF OPERATION	4-1
4.1	MODEL DIFFERENCES	4-1
4.2	BLOCK DIAGRAM	4-1
4.2.1	RS232 HANDSHAKE SEQUENCE	4-1
4.2.2	DATA FLOW FROM READER	4-3
4.2.3	EXTERNAL DATA FLOW IN	4-4
4.2.4	MODEM AND TERMINAL PORTS COMMUNICATION	4-4
4.2.5	ECHO MODE OPERATION	4-4
4.2.6	CODE DETECTION	4-4
4.2.7	READER/PUNCH CONTROL	4-5
4.2.8	SYSTEM READY LOGIC	4-5
4.3	CIRCUIT DESCRIPTIONS	4-5
4.3.1	SYSTEM CLOCK CIRCUITS	4-6
4.3.2	UART DESCRIPTION	4-6
4.3.3	RS232 HANDSHAKE LOGIC	4-7
4.3.3.1	Terminal to Interface	4-7
4.3.3.2	Interface to Terminal	4-7
4.3.3.3	Modem to Interface	4-8
4.3.3.4	Interface to Modem	4-8
4.3.4	DATA FLOW FROM READER	4-8
4.3.5	DATA FLOW FROM TERMINAL , MODEM OR TTY	4-9
4.3.6	MONITOR MODE	4-9
4.3.7	ECHO MODE	4-9
4.3.8	CODE DETECTION	4-10
4.3.9	READER CONTROL LOGIC	4-11
4.3.10	PUNCH CONTROL LOGIC	4-11

TABLE OF CONTENTS
(CONTINUED)

Section	Title	Page
4.3.11	END OF TEXT/CARRIAGE RETURN LOGIC	4-11
4.3.12	TBRL LOGIC	4-12
4.3.13	DATA TERMINAL READY LOGIC	4-12
4.3.14	POWER SUPPLY CIRCUITS	4-14
V	MAINTENANCE.	5-1
5.1	GENERAL.	5-1
5.2	TROUBLE-SHOOTING	5-1
5.3	MAINTENANCE AIDS	5-6
5.3.1	POWER SUPPLY VOLTAGES	5-6
5.3.2	TEST POINTS	5-6
5.3.3	CLOCK	5-7/5-8
5.3.4	CARRIAGE RETURN DELAY ONE-SHOT ADJUSTMENT	5-7/5-8
VI	PARTS REPLACEMENT.	6-1
6.1	GENERAL.	6-1
6.2	PARTS REPLACEMENT	6-1
6.2.1	COVER REMOVAL	6-2
6.2.2	PRINTED CIRCUIT CARD REMOVAL	6-2
VII	PARTS LIST	7-1
7.1	GENERAL.	7-1
7.2	KIT OF PARTS	7-1
VIII	SCHEMATIC DRAWINGS	8-1
8.1	GENERAL.	8-1

LIST OF ILLUSTRATIONS

Figure	Title	Page
1-1	Model RJA2321	1-2
1-2	Model RJA2322	1-2
1-3	Model RJR2321	1-2
1-4	Installation Drawing, RJX232X	1-5
1-5	REMEX Model Number Coding	1-6
2-1	RJX232X Interface Signal Connections	2-2
2-2	Interconnect Cable Assembly, 113619-001	2-4
2-3	Rear View of RJA2322 Showing Location of Connectors, Fuse and A.C. Power Select Switch	2-5/2-6
3-1	Modem or Local Processor to Reader and Punch RS-232-C Connections	3-14
3-2	Terminal or CRT to Reader and Punch RS-232-C Connections	3-15
3-3	Typical Multidevice System Configuration RS-232-C and Current Loop Connections	3-16
3-4	Typical Serial Connection 20mA Current Loop	3-17
3-5	Spare Port Jumpering for Tape Duplication.	3-18
4-1	Block Diagram for the RJA2322	4-2
7-1	REMEX Interface, Model RJA2322	7-7
7-2	REMEX Interface, Model RJA2321	7-8
7-3	Chassis Assembly, Model RJA2322	7-9
7-4	Chassis Assembly, Model RJA2321	7-10
8-1	Schematic RJX232X, Card 113771-001,002,003, Revs A-C	8-3/8-4
8-3	Schematic RJX232X, Card 113771-001, Rev D and above .	8-15/8-16

LIST OF TABLES

Table	Title	Page
1-1	Equipment Supplied	1-1
1-2	Specifications for the RJX232X	1-4
1-3	RJX232X Options (No Options at this Printing)	1-7
2-1	Factory Settings of P.C. Card Controls	2-3
3-1	Input/Output Signal Descriptions	3-2
3-2	Front Panel Controls.	3-3
3-3	Controls and Switches Mounted on the P.C. Card.	3-4
3-4	Recommended Switch Setting For Various Data Flow Directions	3-6
3-5	ASCII Control Characters	3-8
3-6	Reader Stop Character Select	3-9
4-1	RS232 Sequence	4-3
4-2	Signal Mnemonics	4-13
5-1	Maintenance Equipment Required	5-1
5-2	Troubleshooting	5-3
5-3	Power Supply Voltages	5-6
5-4	Test Points on the Circuit Card	5-7/5-8
7-1	Recommended Spare Parts	7-2
7-2	Parts List, RJA2322, RJA2321, RJR2321	7-3
7-3	Parts List Interface Card 113381-001, -002, -003	7-4

SECTION I

GENERAL DESCRIPTION

1.1 EQUIPMENT DESCRIPTION

This manual has been prepared to assist the user in installing, operating and maintaining the following Reader/Punch Serial Interface models: RJA2322, RJA2321 and RJR231. See Figures 1-1 through 1-3. These interfaces convert REMEX 6000 and 7000 series readers, all perforators and reader/perforator combination systems to RS232C signals. Model RJA2322 is designed for a reader/punch and two RS232C ports, model RJA2321 is designed for a reader/punch and one RS232C port and model RJR2321 is designed for a reader only and one RS232C port. See Figure 1-5 and Section 1.6 for a complete description of the model number.

Model RJA2322 has a modem port for connecting a device such as a modem or computer and a terminal port for connecting a device such as a CRT terminal or printer. The modem connector is a DB25P type and the terminal is a DB25S. Models RJA2321 and RJR2321 have the modem port only.

The current loop interface is accessible via the ribbon-cable connector, J3 (reader/punch connector) and is factory wired to 20 mA internal loop source. Provisions have been made for a change to 60 mA and/or external loop source. Model RJR2321 does not contain the current loop port.

1.2 EQUIPMENT SUPPLIED

Various items have been included with the interface for spare parts, installation and maintenance. These items are listed in Table 1-1.

Table 1-1. Equipment Supplied

<u>Item</u>	<u>REMEX Part No.</u>	<u>Quantity</u>
Cable Assembly, Interconnect	113619-001	1
Cap, Fuseholder	705750-118	1
Connector, 25-pin, Cannon DB-25S, P1	706510-211	1
Connector, 25-pin, Cannon DB-25P, P2	706500-231	1
Fuse, 0.125 amp, 250V	705710-104	1
Junction Shell, Cannon DB24659 (P1, P2)	706540-144	2
Manual	112670-092	1
Power Cord	708000-110	1
Screw Lock Assembly, Cannon D20419 (P1, P2)	706540-124	2

1.3 EQUIPMENT WARRANTY

A statement covering the warranty of this equipment is given on page iii (second page in book). It should be read and understood. All preventive maintenance procedures must be performed as outlined in Section 5.2 during the warranty period in order that the warranty remain in effect. Any question arising concerning the warranty should be directed to the REMEX Service Department.

1.4 MAINTENANCE EQUIPMENT REQUIRED BUT NOT SUPPLIED

The maintenance procedures in Section 5 require equipment that is not supplied. This equipment is listed in Table 5-1.

1.5 SPECIFICATIONS

Listed in Table 1-2 are the characteristics and specifications for the RJX232X series of interfaces. Also see Section 1.6 for complete model number description and Figure 1-5 which indicates how the options are incorporated into the model structure. An X in a particular digit designator denotes any of the combinations given in Figure 1-5 are applicable. Model designations using X's are frequently used throughout the manual, especially the parts list. Refer to Table 3-1 for signal descriptions.

1.6 MODEL NUMBER DESIGNATION

The REMEX model designation is used to code the basic functions, options and configurations of a particular product line. Figure 1-5 illustrates the model code structure for the RS232 interface and indicates the various models and options. An X in a particular digit designator (as used in many parts of this manual, especially the parts list) denotes any of the combinations given in Figure 1-5 can be used.

Nonstandard (special) units use the last three numbers of the model number to denote a special unit. The difference between any special unit and the standard unit is described in an addendum at the end of the manual. Units with 000 and 901 or higher are standards and are covered in this manual without addendums.

Standard options not shown in Figure 1-5 are used in the 901 and higher numbers (standard units only) and are listed on the serial tag in the options block in the form of a series of three digit numbers depending upon the number of options the unit contains. For example, a unit with 902 in the last three digits of the model number would list two three digit numbers. Because the entire list of possible options is constantly changing and includes special customer requirement it is not included in the manual. Table 1-3 does list those option numbers which are applicable to all units.

Always consult the serial number tag for proper voltage and frequency to be used and for model identification. Failure to do so could result in damage to the unit. The serial tag is located on one of the rear surfaces. In all correspondence, always refer to the complete model number including the last three numbers and the unit's serial number. Refer to the CAUTION in Section 2.4.

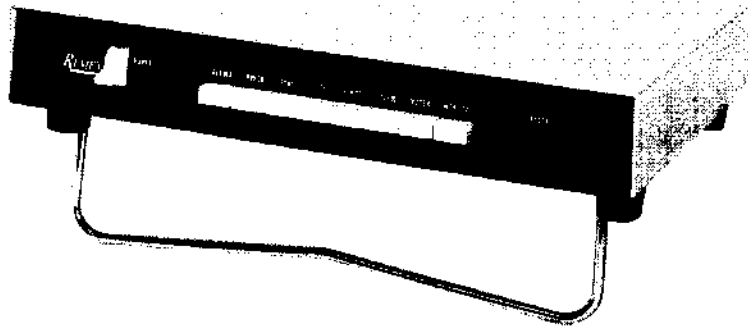

Figure 1-1. Model RJA2321.

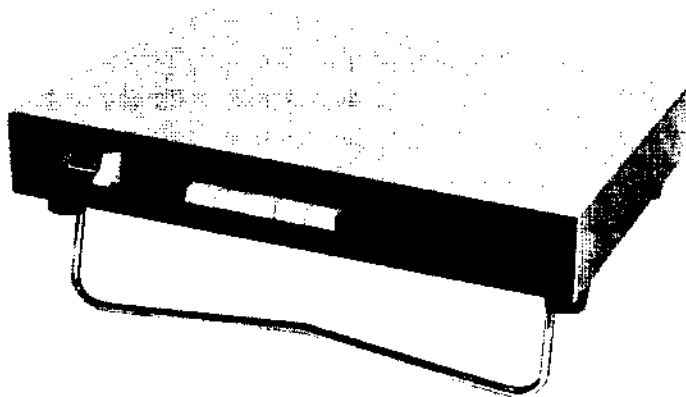

Figure 1-2. Model RJA2322.

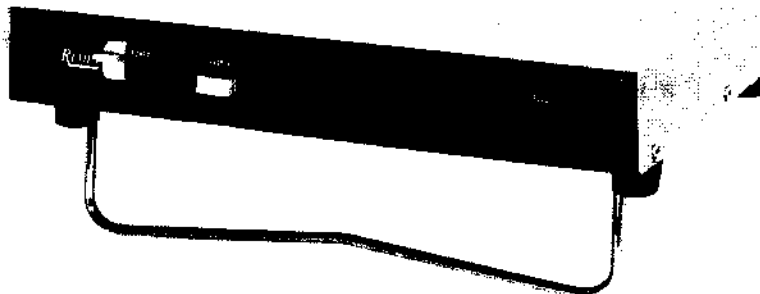

Figure 1-3. Model RJR2321.

Table 1-2. Specifications for the RJX232X

Characteristics	Specification																				
I/O PORTS	RJA2322 has one modem port (J1) which is used to connect a device such as a model or a computer. The other is the terminal port (J2) which is used to connect a device such as a CRT terminal or printer. Connecting schemes to the ports may vary just as long as the signal directions (in or out) are observed. The RJA-2321 and RJR2321 have only the modem port.																				
REMOTE CONTROL CHARACTERS	The interface may be controlled remotely by ASCII Control characters. The control set is decoded by a PROM.																				
MODES OF OPERATION	<p>The following are the general operating modes:</p> <ol style="list-style-type: none"> Reader and punch communicate with the device on the modem port under local or remote control. Reader and punch communicate with the device on the terminal port under local or remote control. Reader and punch communicate with the device in the current loop under local or remote control. Device on terminal port communicates with device on modem port and punch monitors data coming in modem port. Punch control may be local or remote. Reader can be active in local or remote. When active, reader data overrides terminal data going to modem. Input data is punched and echoed back to data source. Any port may be selected. Punch control may be local or remote; reader is inactive. 																				
DATA RATES	<p>Both Input and Output data rates are factory set for 1200 Baud. Other rates available are:</p> <table border="1" style="width: 100%; border-collapse: collapse;"> <thead> <tr> <th colspan="2"><u>Input Data Rates to Punch</u></th> <th colspan="2"><u>Output Data Rates from Reader</u></th> </tr> </thead> <tbody> <tr> <td>110 Baud</td> <td>600 Baud</td> <td>110 Baud</td> <td>1200 Baud</td> </tr> <tr> <td>150 Baud</td> <td>1200 Baud</td> <td>150 Baud</td> <td>2400 Baud</td> </tr> <tr> <td>300 Baud</td> <td></td> <td>300 Baud</td> <td>4800 Baud</td> </tr> <tr> <td></td> <td></td> <td>600 Baud</td> <td>9600 Baud</td> </tr> </tbody> </table> <p>See Table 3-3 for jumper selections for other rates.</p>	<u>Input Data Rates to Punch</u>		<u>Output Data Rates from Reader</u>		110 Baud	600 Baud	110 Baud	1200 Baud	150 Baud	1200 Baud	150 Baud	2400 Baud	300 Baud		300 Baud	4800 Baud			600 Baud	9600 Baud
<u>Input Data Rates to Punch</u>		<u>Output Data Rates from Reader</u>																			
110 Baud	600 Baud	110 Baud	1200 Baud																		
150 Baud	1200 Baud	150 Baud	2400 Baud																		
300 Baud		300 Baud	4800 Baud																		
		600 Baud	9600 Baud																		
DIMENSIONS	See Installation Drawing, Figure 1-4.																				
TEMPERATURE	<p>Operating: 0° to 55°C free air</p> <p>Storage: -55°C to +85°C</p>																				
HUMIDITY	<p>Operating: 10% to 90% relative humidity (without condensation)</p> <p>Non-Operating: All conditions without condensation of either water or frost.</p>																				
POWER	115 VAC @ 90 mA; 230 VAC @ 45 mA, max.																				
WEIGHT	7 lbs.																				

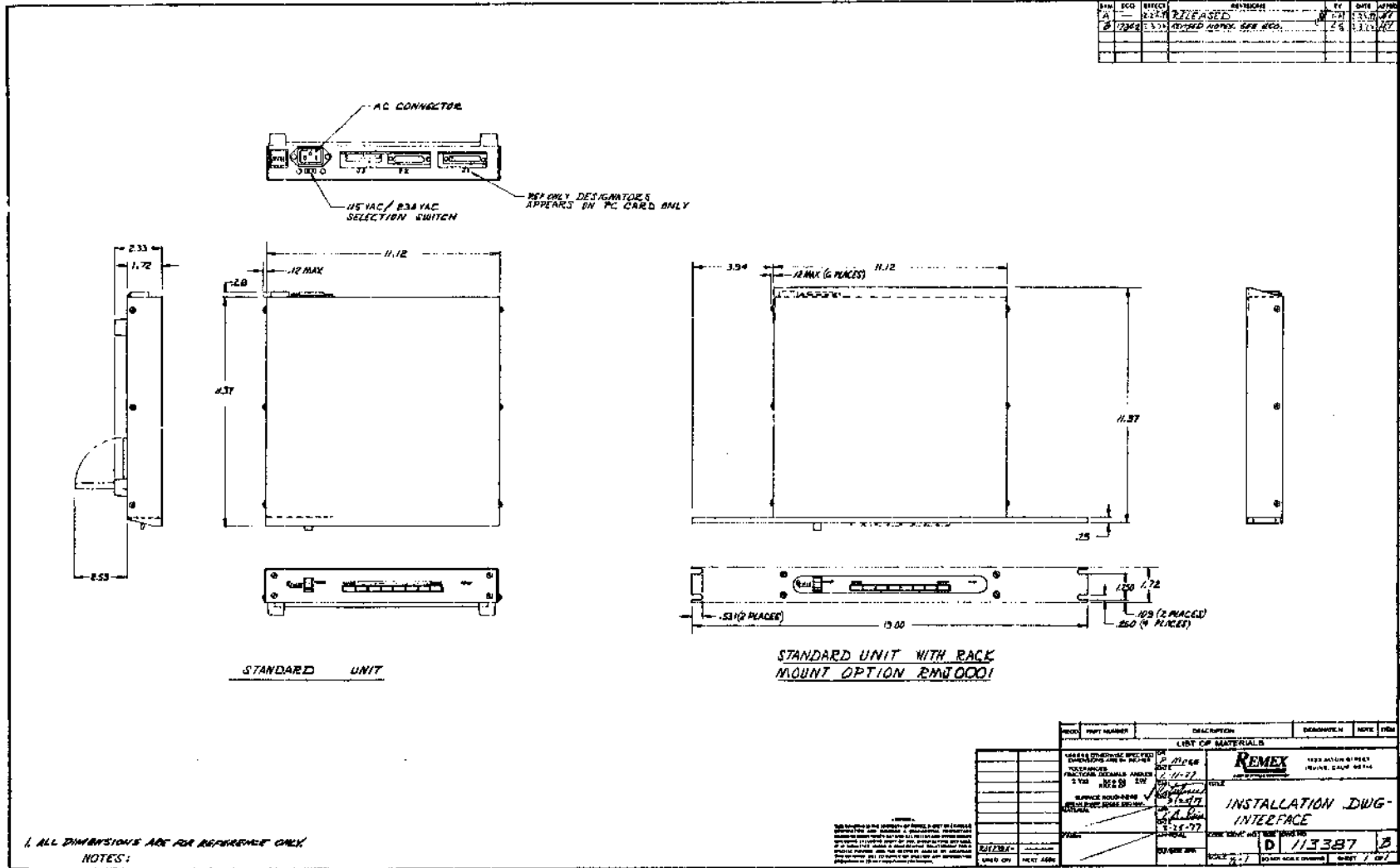

Figure 1-4. Installation Drawing, RJX232X.

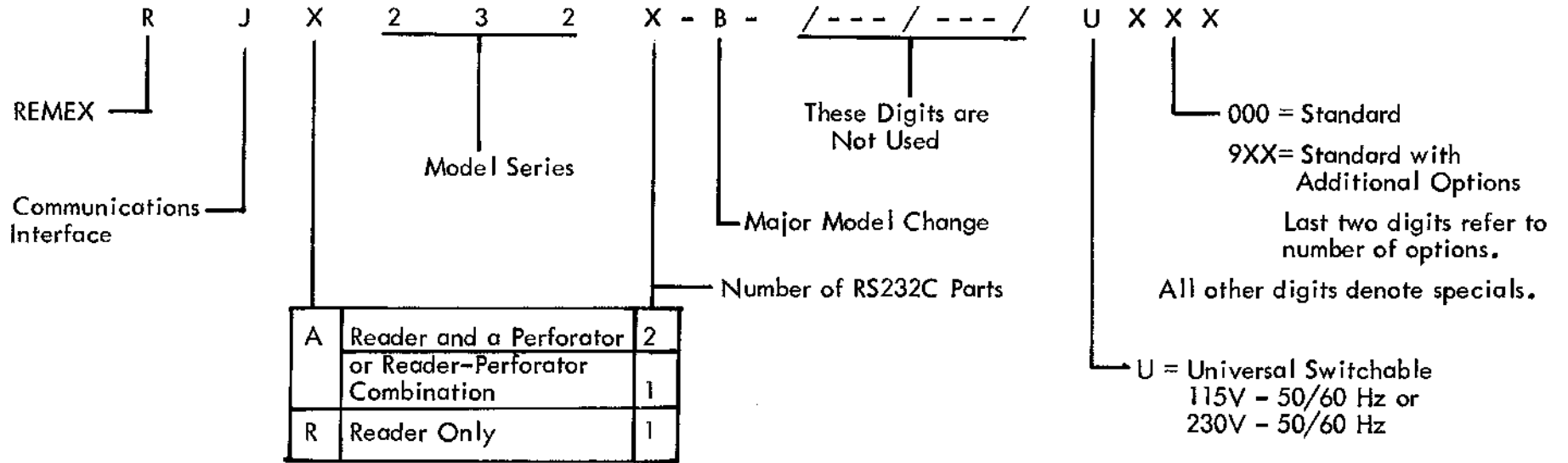

Figure 1-5. REMEX Model Number Coding.

1.7 PHYSICAL DESCRIPTION

The REMEX RS232 interface is available as a desk top unit with stand or with the rackmount option. Detail dimensions are shown in Figure 1-4. The operating controls are located on the front of the unit and the connectors and fuse are located at the rear.

Table 1-3. RJX232X Options

No Options at this Printing

1.8 ACCESSORIES

A rack mount option, part number 811692-231 is available. Order REMEX RMJ0001, Rack Mount Option. The kit consists of 1-3/4 in. high x 19 in. wide by 1/4 inch thick panel with attaching screws and installation drawing.

SECTION II

INSTALLATION

2.1 UNPACKING

Specially designed, reinforced packing cartons have been used in the shipment of the RS232 Interface to provide the best possible protection during transit. Also packed with the unit in a separate plastic bag is the kit of parts listed in Table 1-1. A careful visual inspection of the unit should be made as soon as it is removed from the carton for any apparent damage incurred during shipping. In the event the unit has been damaged as a result of shipping, the carrier and REMEX should be notified as soon as possible. When carrying or removing the unit from the carton, always lift with both hands under the unit. Never attempt to lift it by the covers, stand or switches or other parts which may not support the weight of the unit.

2.2 SYSTEM MOUNTING

The unit is available in a desk top configuration with a tilt-up stand or as an optional rack mounted unit. See Figure 1-4. Four screws are used to mount the unit in a 19-inch rack.

2.3 INITIAL ADJUSTMENTS

In addition to the front panel controls, the printed circuit board contains several switches and controls which provide the interface with its many features. Generally once the unit is placed in a fixed system, these controls need to be set to one configuration and left alone. Table 3-3 lists the various control switches and their functions. Table 2-1 gives the factory setting for each switch. If different settings are required, remove AC power cord. Remove the six 4-40 binderhead machine screws which hold the cover to the chassis and remove the cover. Place the switches in the desired configuration and replace the cover. Reapply power. See Figure 7-3 (RJA2322) or Figure 7-4 (RJA2321) for location of P.C. card controls.

The unit also contains a selector switch (S102; see Figure 2-3) for 115 VAC or 230 VAC power selection. This switch is factory set to 115 VAC. If 230 VAC operation is required, remove the power cord, place the switch in its 230 VAC position and reapply the power cord.

<u>Modem Port</u>	<u>Terminal Port</u>
J1-1 -- Protective Ground	J2-1 -- Protective Ground
J1-2 -- Modem Transmitted Data* Output	J2-2 -- Terminal Transmitted Data* Input
J1-3 -- Modem Received Data* Input	J2-3 -- Terminal Received Data* Output
J1-4 -- Modem Request to Send Output	J2-4 -- Terminal Request to Send Input
J1-5 -- Modem Clear to Send Input	J2-5 -- Terminal Clear to Send Output
J1-6 -- Modem Data Set Ready Input	J2-6 -- Terminal Data Set Ready Output
J1-7 -- Signal Ground	J2-7 -- Signal Ground
J1-20 -- Modem Data Terminal Ready Output	J2-20 -- Terminal Data Terminal Ready Input
J1-25 -- TTL Input	

READER/PERFORATOR/CURRENT-LOOP PORT

J3-1 -- Reader Data 2*	J3-18 -- Reader Signal Ground
J3-2 -- Reader Data 1*	J3-19 -- Reader Data 3*
J3-3 -- Reader System Ready*	J3-20 -- Reader Data 5*
J3-4 -- Reader Winding*	J3-21 -- Reader Data 4*
J3-5 -- Reader Data Ready*	J3-22 -- Reader Data 6*
J3-6 -- Reader Drive Left*	J3-23 -- Reader Data 7*
J3-7 -- Reader Drive Right*	J3-24 -- Reader Data 8*
J3-8 -- Punch System Ready*	J3-25 -- Punch Signal Ground
J3-9 -- Punch Tape/Chad Error	J3-26 -- Punch Data 8*
J3-10 -- Punch Ready	J3-27 -- Punch Data 7*
J3-11 -- Punch Direction	J3-28 -- Punch Data 6*
J3-12 -- Punch Data 3*	J3-29 -- Punch Data 1*
J3-13 -- Punch Data 2*	J3-30 -- Punch Command
J3-14 -- Punch Data 5*	J3-31 -- Punch Data 4*
J3-15 -- TTY IN - (current flows out this pin)	J3-32 -- No Connection
J3-16 -- TTY IN +(current flows in this pin)	J3-33 -- Key
J3-17 -- TTY OUT - (current flows out this pin)	J3-34 -- TTY OUT +(current flows in this pin)

Figure 2-1. RJX232X Interface Signal Connections.
J2 is present on RJA2322 Only.

2.4

POWER AND SYSTEM CONNECTIONS

A.C. power is applied to the unit through a standard three-wire power cord to the power connector (FL1) located at the rear of the unit. Refer to Figure 2-3 for location of connectors.

CAUTION

All units come wired for 115 VAC, 47-64 Hz operation. If 230 VAC operation is required, remove power, place the power select switch mounted above the AC connector into the 230 VAC position and reapply power. In addition before operating the unit, the fuse and fuseholder cap must be removed from the kit of parts (see Table 1-1) and mounted at the rear of the unit next to the AC connector.

All modem signals are routed through J1 and all terminal signals are routed through J2 (RJA2322 unit only). Reader and perforator connections as well as current loop connections are made at J3. Figure 2-1 lists the signals associated with each pin and their description is given in Table 3-1. The proper mating connectors for J1 and J2 have been supplied. An interconnection cable assembly (113619-001) for J3 and the reader/perforator combination and TTY is also furnished. The connector which connects to the reader is stamped with an R and the connector which connects to the punch is stamped with a P. The TTY connection has no connector. Figure 2-2 illustrates the connector assembly.

2.5

INTERFACE CIRCUITRY

To accommodate a wide range of signals required for the interface, various types of interfacing I.C. modules are used. Table 3-2 lists the various signals and the chart at the bottom of the table gives the various I.C.'s used for each signal.

Table 2-1. Factory Settings of P.C. Card Controls

<u>Switch</u>	<u>Setting</u>
Send Data Rate	J8-4 and J9-4 (1200 Baud)
Received Data Rate	J10-5 and J11-5 (1200 Baud)
Receive Current Loop	TU and VW (Internal, 20 mA)
Send Current Loop	LM, NP, and RS (Internal, 20 mA)
PEN (Switch S9)	ON (Parity Enabled)
1SB (Switch S9)	ON (One Stop Bit)
CL2 (Switch S9)	OFF
CL1 (Switch S9)	ON
ODD (Switch S9)	ON (Odd Parity)
PCH IN (Switch 10)	ON (Punch Connected)
NO PICK (Switch 10)	ON (Disable Reader Single Step)
RDR IN (Switch 10)	ON (Reader Connected)
DSR IN (Switch 10)	ON (DSR Internal)
CTS EXT (Switch 10)	OFF (CTS Internal)
PAR DTR (Switch 10)	OFF (Parity Error Doesn't Inhibit Ready)
NO CR (Switch 10)	ON (Enable Auto Reader Stop and Disable Auto Reader Delay)
Reader Stop or Delay Character	ETX (See Table 3-3)

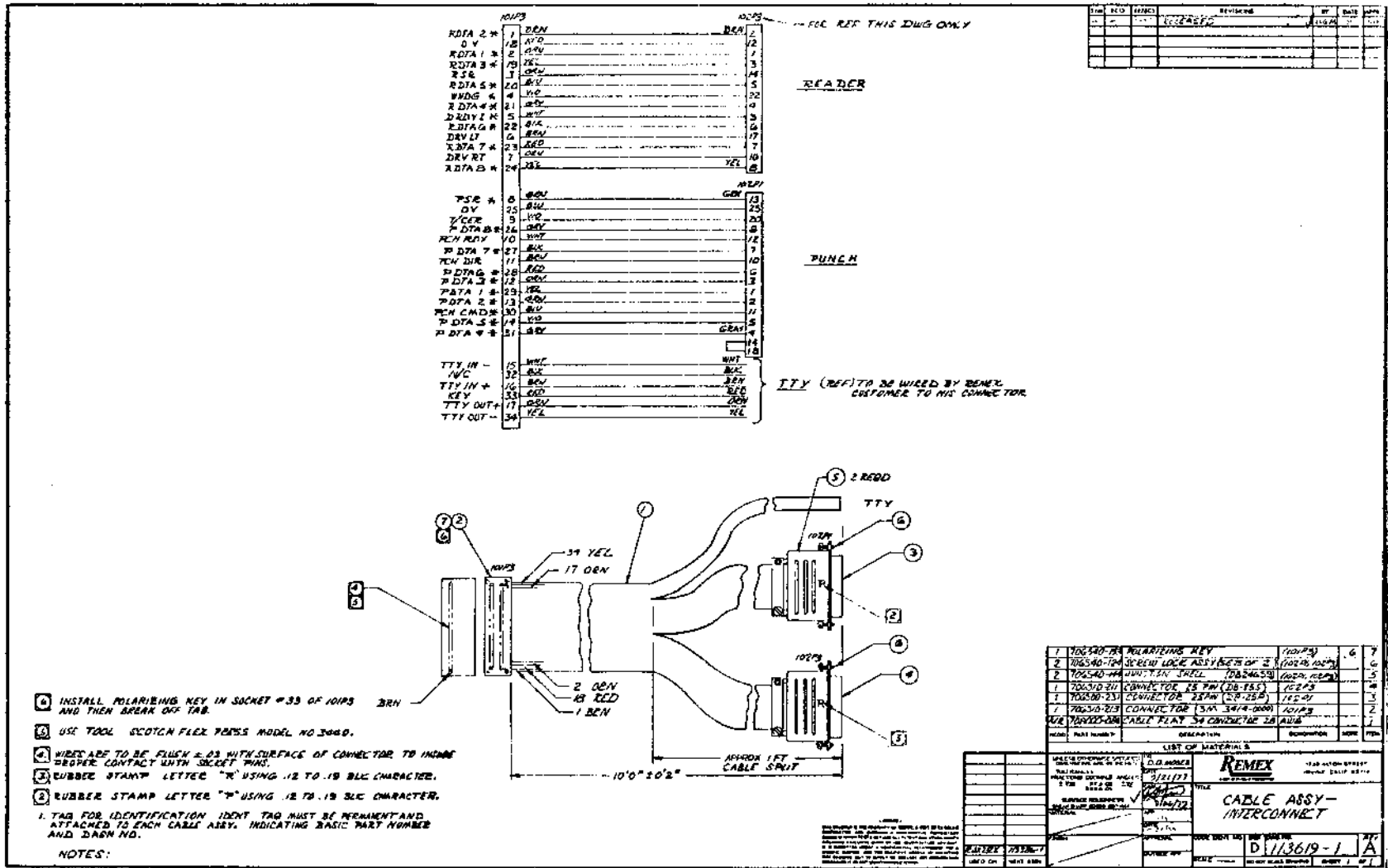

Figure 2-2. Interconnect Cable Assembly, 113619-001.

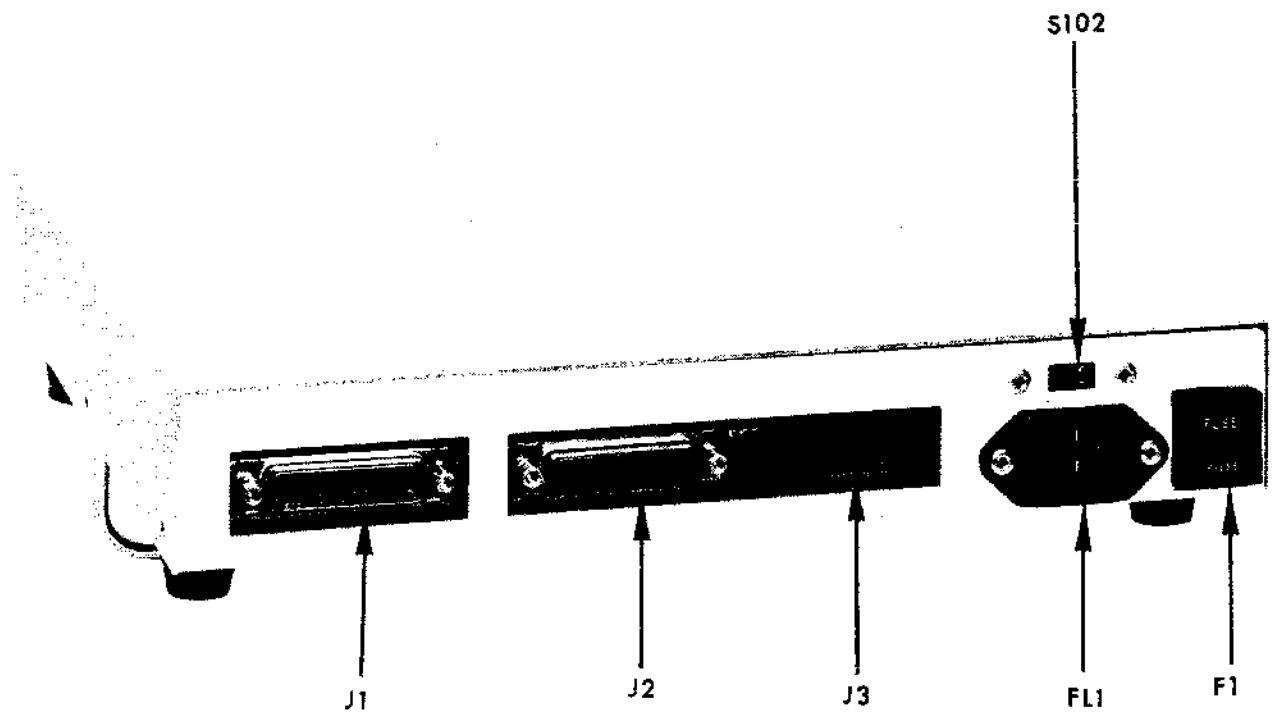

Figure 2-3. Rear View of RJ2322 Showing Location of Connectors, Fuse and A.C. Power Select Switch.

SECTION III

OPERATION

3.1 INPUT-OUTPUT SIGNALS

Table 3-1 lists the input and output signals which are routed through J1, J2 and J3. The definition and/or usage of these signals are also included in the table. The various interface IC's used and the signal levels are shown at the bottom of the table and are keyed to the signal by a circled letter.

3.2 CONTROL FUNCTIONS

Table 3-2 lists the front panel operating controls along with their descriptions and functions. Table 3-3 contains the description of the various controls and switches mounted on the P.C. Board. These controls are set at the beginning of an installation and generally do not require resetting. Table 2-1 gives the factory setting for these switches and if they require resetting the procedure is described in Section 2.3.

3.3 OPERATING INSTRUCTIONS

Because of the many features of the unit, several combination of operating conditions are possible. Once the user has become familiar with all the features he may tailor the interface to suit his particular equipment. The following are the general modes of operation and the operating procedures in the order they should be performed. Table 3-4 summarizes the various data flow paths and the required switch settings along with optional switch settings.

3.3.1 MODES OF OPERATION

The following list contains the general operating modes. Not all models contain the same features. See Section 1.1 for equipment description.

- a. Reader and Punch communicate with the device on the Modem port under local or remote control.
- b. Reader and Punch communicate with the device on the Terminal port under local or remote control.
- c. Reader and Punch communicate with the device(s) in the current loops under local or remote control.
- d. Device on Terminal port communicates with device on Modem port and punch monitors data coming in Modem port. Punch control may be local or remote control. Reader is inactive. When reader is selected, reader data goes to Modem port instead of the terminal port data.

Table 3-1. Input/Output Signal Descriptions.

CONNECTOR PIN		SIGNAL DESCRIPTION		
M O D E M	J1-1	Protective ground connected to the chassis. Isolated from signal ground except for a 0.01µf capacitor between chassis and signal grounds.		
	J1-2 (F)	Modem Transmitted Data (MODEM XMTD*) Output. Serial output data line of the Modem port. True condition is low. This line stays in the true condition when no data is being put out. The serial word configuration consists of a start bit, data bits, a parity bit, and stop bits. The parity bit may be even or odd. Stop bits may number one, two, or one and a half (5 data bit word only).		
	J1-3 (A)	Modem Received Data (MODEM RCVD*) Input. Serial input data line from the Modem port. True condition is low. When no data is being transferred, this line must remain in the true condition. The serial word is as described for J1-2, Modem Transmitted Data.		
	J1-4 (G)	Modem Request to Send (MODEM RTS) Output. True (high level) indicates the interface is ready to send data to the Modem on the MODEM XMTD* line. The signal is true under the following conditions: (1) when MODEM switch is depressed and either MODEM CTS input is false or Clear to Send switch is OFF (board mounted) and the reader is ready to read, or (2) when MONITOR switch is depressed and the TERM RTS signal is true or reader is ready to read.		
	J1-5 (B)	Modem Clear to Send (MODEM CTS) Input. True (high level) indicates that the device connected to the MODEM port has responded to a Request to Send (J1-4) signal and is ready to accept data. This signal should only go true after a Request to Send signal has been issued. At all other times it must remain false. If the signal does not conform to these requirements, the CLEAR TO SEND switch must be OFF (board mounted).		
	J1-6 (B)	Modem Data Set Ready (MODEM DSR) Input. True (high level) indicates that the device connected to the Modem port has power on and is otherwise ready. A true level has no connection as to whether or not data is flowing. If the device does not provide this signal, the DATA SET READY switch must be ON (board mounted).		
	J1-7	Signal ground return for the modem port. A 0.01µf capacitor connects from signal ground to chassis ground.		
	J1-20 (C)	Modem Data Terminal Ready (MODEM DTR) Output. True (high level) indicates to the Modem that the interface is ready, but not necessarily ready for data interchange. The signal is true under the following conditions: (1) when the MODEM switch is depressed and both the reader and punch are ready; or (2) when MONITOR switch is depressed and the TERM DTR and reader punch is ready.		
	J1-25 (C)	PICK* Input. True signal (low) causes reader to step the tape one character for each input pulse. The NO PICK switch (board mounted) must be OFF. Data will go out the selected port of the character rate determined by the PICK* signal.		
	T E R M I N A L	J2-1	Protective ground connected to the chassis. Isolated from signal ground except for a 0.01µf capacitor between chassis and signal grounds.	
J2-2 (A)		Terminal Transmitted Data (TERM XMTD*) Input. Serial input data line from the terminal port. True condition is low. When no data is being transferred, this line must remain in the true condition. The serial word is as described for J1-2, Modem Transmitted Data.		
J2-3 (F)		Terminal Received Data (TERM RCVD*) Output. True (low level). Serial output data of the terminal port. This line stays in the true condition when no data is being put out. The serial word is as described for J1-2, Modem Transmitted Data.		
J2-4 (B)		Terminal Request to Send (TERM RTS) Input. True (high level) indicates that the device connected to the Terminal port is ready to send data to the interface on the TERM XMTD* line. If the interface is ready it will respond with a Clear to Send signal to the Terminal port (providing the Clear to Send board mounted switch is ON).		
J2-5 (G)		Terminal Clear to Send (TERM CTS) Output. True (high level) indicates that the interface is ready to accept data from the Terminal on the TERM XMTD* line. It is true under the following conditions: (1) when the TERMINAL switch is depressed and the TERM RTS signal (J2-4) is high or the Clear to Send board mounted switch is OFF and the punch is ready to accept data, or (2) the MONITOR switch is depressed and MODEM CTS (J1-5) signal is true.		
J2-6 (G)		Terminal Data Set Ready (TERM DSR) Output. True (high level) indicates to the Terminal that the interface is ready but not necessarily ready for data interchange. It is true under the following conditions: (1) when the TERMINAL switch is depressed and both the reader and punch are ready, or (2) when the MODEM or MONITOR switch is depressed and the MODEM DSR signal (J1-6) is true.		
J2-7		Signal ground return for the terminal port. A 0.01µf capacitor connects from signal ground to chassis ground.		
J2-20 (B)		Terminal Data Terminal Ready (TERM DTR) Input. True (high level) indicates that the device connected to the terminal port has power on and is otherwise ready. The true level has no connection as to whether or not data is flowing. If the device does not provide this signal, then the Data Set Ready board mounted switch must be ON.		
R E A D E R / P U N C H A N D C U R R E N T L O O P	J3-1 (K)	Reader Data 2*	J3-18	Reader Signal Ground
	J3-2 (K)	Reader Data 1*	J3-19 (K)	Reader Data 3*
	J3-3 (K)	Reader System Ready*	J3-20 (K)	Reader Data 5*
	J3-4 (K)	Reader Winding*	J3-21 (K)	Reader Data 4*
	J3-5 (K)	Reader Data Ready*	J3-22 (K)	Reader Data 6*
	J3-6 (K)	Reader Drive Left*	J3-23 (K)	Reader Data 7*
	J3-7 (K)	Reader Drive Right*	J3-24 (K)	Reader Data 8*
	J3-8 (K)	Reader System Ready*	J3-25	Punch Signal Ground
	J3-9 (J)	Punch Tape/Chad Error	J3-26 (K)	Punch Data 8*
	J3-10 (J)	Punch Ready	J3-27 (K)	Punch Data 7*
	J3-11 (K)	Punch Direction*	J3-28 (K)	Punch Data 6*
	J3-12 (K)	Punch Data 3*	J3-29- (K)	Punch Data 1*
	J3-13 (K)	Punch Data 2*	J3-30 (K)	Punch Command*
	J3-14 (K)	Punch Data 5*	J3-31 (K)	Punch Data 4*
	J3-15 (D)	TTY IN - Input. Current loop input line. Current flows out on this line. True condition is when current is flowing or when no data is being transmitted.	J3-32	No Connection
J3-16 (E)	TTY IN + Input. Current input line (sink). Current flows in on this line.	J3-33	Key	
J3-17 (I)	TTY OUT + Output. Current loop output line (sink). Current flows in on this line.	J3-34 (H)	TTY OUT - Current loop output line (source). Current flows out on this line. True condition is when current is flowing or when no data is being transmitted.	

NOTE: 1 Refer to Reader/Punch Data Sheets for description of pins J3-1 thru J3-14 and J3-18 thru J3-31.
 2 Circled letters refer to interface. See Table 4 page 4.

Table 3-1. Input/Output Signal Descriptions (Continued)

DESIGNATION	I.C. INTERFACE	TRUE CONDITION	FALSE CONDITION	DESIGNATION	I.C. INTERFACE	TRUE CONDITION	FALSE CONDITION
A	SN75189 Must be driven by SN75188 or equiv.	-25 to -3 volts @ 8.3 mA, max.	+3 to +25 volts @ 8.3 mA, max.	F	SN75188 Must be interfaced to SN75189 or equivalent.	-7 to -5 Vdc @ 10 mA, max.	+5 to +7 Vdc @ 10 mA, max.
B	SN75189 Must be driven by SN75188 or equivalent.	+3 to +25 volts @ 8.3 mA, max.	-25 to -3 volts @ 8.3 mA, max.	G	SN75188 Must be interfaced to SN75189 or equivalent.	+5 to +7 Vdc @ 10 mA, max.	-7 to -5 Vdc @ 10 mA, max.
C	74C906	$0 < V < +0.4$ @ 0.5 mA, max. (source). Min. pulse width is 2 μ sec.	$+2.4 < V < +5.2$ (or open circuit)	H	70 ohms to +8 Vdc	20 mA nominal, depending upon loop impedance.	1 μ A, maximum
D	4N28 (LED to 8 Vdc thru 270 ohm)	20 mA, nominal, depending upon loop impedance.	100 μ A, maximum	I	Open collector of MP SA06 switching transistor.	20 mA nominal, depending upon loop impedance.	1 μ A, maximum
E	270 ohms to ground	20 mA, nominal depending upon loop impedance.	100 μ A, maximum	J	See Reader/Punch Data Sheet. Must operate in Mode 5.	$+2.5 < V < +5.2$ @ 0.9 mA, max. (mode 5)	$0 < V < +0.4$ @ 3.2 mA max.
				K	See Reader/Punch Data Sheet. Must operate in Mode 6.	$0 < V < +0.4$ @ 3.2 mA max. (mode 6)	$+2.5 < V < +5.2$ @ 0.9 mA max.

Table 3-2. Front Panel Controls

SWITCH	DESCRIPTION
POWER	Applies AC power to unit.
READER	When depressed, allows the reader to read tape provided interface is in 'local' mode (REMOTE switch out).
PUNCH	When depressed, allows incoming serial data to be punched if the interface is in 'local' mode (REMOTE switch out). Not applicable to RJR 2321.
ECHO	When depressed, causes the incoming serial data to be echoed back to the data source via the output port. Data is also punched and reader is inactive. Not applicable to RJR 2321.
TTY	When depressed, enables the input/output current-loop port and disables the RS232C input/output ports. Not applicable to RJR 2321.
REMOTE	When depressed, allows remote control of the reader and the punch via the selected input port. Seven ASCII control characters are used and are not punched. When the switch is out, control is via the front panel Reader and Punch Switches (Local mode). In local mode the seven ASCII control characters are punched. Not applicable to RJR 2321.
TERMINAL	When depressed, selects the terminal input/output port and forces the MONITOR and MODEM switches out. The TTY switch must be out. The board mounted CTS EXT switch must also be off. Applies to RJA 2322 Only.
MODEM	When depressed, selects the modem input/output port and forces the TERMINAL and MONITOR switches out. The TTY switch must be out. Applies to RJA 2322 Only.
MONITOR	When depressed, selects the monitor mode and forces the TERMINAL and MODEM switches out. The TTY switch must be out. In this mode, the Terminal port communicates with the Modem port and the punch monitors (punches) the data coming in the Modem port. Do not operate any device inputting to the terminal port (example: CRT=Keyboard) while reading punch tape. Both devices can transmit to the MODEM port at the same time causing data to become scrambled. Reader and punch control may be local or remote. Applies to RJA 2322 Only.
READY INDICATOR	Indicates that the reader and punch are ready to communicate. Also, if the board-mounted PAR DTR switch is ON, indicates that a parity error does not exist in the incoming serial data. If either the reader or the punch is not connected, the board-mounted RDR IN or PCH IN switches must be properly set.

Table 3-3. Controls and Switches Mounted on the P.C. Card.

Control/Switch	Description																												
Send Data Rate Jumper Plug	Send (reader) data rates are selected by placing the movable jumper plug (P10) in the desired location on connectors J8 and J9 as follows: <table border="1" style="width: 100%; border-collapse: collapse;"> <thead> <tr> <th>J8 and J9 Pin No.</th> <th>BAUD</th> <th>J8 and J9 Pin No.</th> <th>BAUD</th> </tr> </thead> <tbody> <tr> <td>1</td> <td>9600</td> <td>5</td> <td>600</td> </tr> <tr> <td>2</td> <td>4800</td> <td>6</td> <td>300</td> </tr> <tr> <td>3</td> <td>2400</td> <td>7</td> <td>150</td> </tr> <tr> <td>4</td> <td>1200</td> <td>8</td> <td>110</td> </tr> </tbody> </table>	J8 and J9 Pin No.	BAUD	J8 and J9 Pin No.	BAUD	1	9600	5	600	2	4800	6	300	3	2400	7	150	4	1200	8	110								
J8 and J9 Pin No.	BAUD	J8 and J9 Pin No.	BAUD																										
1	9600	5	600																										
2	4800	6	300																										
3	2400	7	150																										
4	1200	8	110																										
Receive Data Rate Jumper Plug	Receive (Punch) data rates are selected by placing the movable jumper plug (P11) in the desired location on connectors J10 and J11 as follows: <table border="1" style="width: 100%; border-collapse: collapse;"> <thead> <tr> <th>J10 and J11 Pin No.</th> <th>BAUD</th> <th>J10 and J11 Pin No.</th> <th>BAUD</th> </tr> </thead> <tbody> <tr> <td>1</td> <td>110</td> <td>4</td> <td>600</td> </tr> <tr> <td>2</td> <td>150</td> <td>5</td> <td>1200</td> </tr> <tr> <td>3</td> <td>300</td> <td></td> <td></td> </tr> </tbody> </table>	J10 and J11 Pin No.	BAUD	J10 and J11 Pin No.	BAUD	1	110	4	600	2	150	5	1200	3	300														
J10 and J11 Pin No.	BAUD	J10 and J11 Pin No.	BAUD																										
1	110	4	600																										
2	150	5	1200																										
3	300																												
Receive Current Loop Jumpers	The current loop input is factory wired for 20mA and internal voltage source. This configuration has jumpers from T to U and V to W. The customer may select an external voltage source by removing the two jumpers and installing a single jumper from T to V; the external source may be 20 or 60mA. The customer may select the internal voltage source @ 60mA by changing both R7 and R9 to 82 ohms, 1/4 watt and leaving in jumpers TU and VW.																												
Send Current Loop Jumpers	The current loop output is factory wired for 20mA and internal voltage source. This configuration connects jumpers from FF to DD and CC to EE. The customer may select an external voltage source by removing jumpers and installing another jumper from CC to DD (the external source may be 20 or 60mA). The above customer may select the internal 60mA by changing R27 to 180 ohms, 1/2 W and leaving in the original jumpers.																												
Parity Enable (PEN)	To enable parity checking of incoming serial data and parity generation for outgoing serial data, set the PEN switch on (lever pointing toward the PEN lettering). In the off position parity checking and generation is disabled.																												
Stop Bit Select (1SB)	To select one stop bit, set the 1SB switch on (lever pointing toward the 1SB lettering). The off position selects 1.5 stop bits for 5-bit characters and 2 stop bits for other character lengths. This applies for both incoming and outgoing serial data.																												
Character Length Switches (CL1, CL2)	The number of data bits in the incoming and outgoing data determine the switch settings as follows: <table border="1" style="width: 100%; border-collapse: collapse;"> <thead> <tr> <th>Data Bits</th> <th>CL1</th> <th>CL2</th> <th>NOTE:</th> </tr> </thead> <tbody> <tr> <td>5</td> <td>ON</td> <td>ON</td> <td rowspan="4">The switches are on when the levers point toward CL1 and CL2 lettering.</td> </tr> <tr> <td>6</td> <td>OFF</td> <td>ON</td> </tr> <tr> <td>7</td> <td>ON</td> <td>OFF</td> </tr> <tr> <td>8</td> <td>OFF</td> <td>OFF</td> </tr> </tbody> </table>	Data Bits	CL1	CL2	NOTE:	5	ON	ON	The switches are on when the levers point toward CL1 and CL2 lettering.	6	OFF	ON	7	ON	OFF	8	OFF	OFF											
Data Bits	CL1	CL2	NOTE:																										
5	ON	ON	The switches are on when the levers point toward CL1 and CL2 lettering.																										
6	OFF	ON																											
7	ON	OFF																											
8	OFF	OFF																											
Even/Odd Parity (ODD)	To enable odd parity checking and generation set the ODD switch on (lever pointing to the ODD lettering). The off position selects even parity checking and generation.																												
Punch Connection (PCH IN)	If the punch is connected, set the PCH IN switch on (lever pointing toward PCH IN lettering). If the punch is not connected, set the switch off; this synthesizes a Punch Ready condition for the READY indicator and the Data Terminal Ready signal.																												
Pick Option (NO PICK)	To enable the reader to be stepped one character at a time, set the NO PICK switch off (lever pointing away from the NO PICK lettering). Reader stepping is now controlled by the PICK* signal at J1-25. Each time the reader is stepped, the serial character is put out at the selected send data rate. The step rate must not exceed the send data rate or the maximum reader speed. To disable stepping one character at a time, set the switch on; this will allow reader stepping to match the send-data rate.																												
Reader Connection (RDR IN)	If the reader is connected, set the RDR IN switch on (lever pointing toward RDR IN lettering). If the reader is not connected, set the switch off. This synthesizes a Reader Ready condition for the READY indicator and Data Terminal Ready signal.																												
Data Set Ready Internal/External (DSR INT)	This switch must be set to match the configuration of the serial device with which the interface is communication. If the serial device puts out a ready signal, then the DSR INT must be off (lever pointing away from DSR INT lettering). If the serial device has no ready signal, set the switch on. This synthesizes the Data Set Ready signal. The switch must be on for current loop operation.																												
Clear to Send Internal/External (CTS EXT)	This switch is set according to the configuration of the serial device connected to the Modem port. If the device on the Modem port has a false clear to send signal which goes true when the interface issues a Request to Send signal, the switch is placed ON (lever pointing to CTS EXT lettering). If these conditions do not exist the switch is placed OFF which synthesizes the Clear to Send signal. When the terminal port is active, the switch can be in either position. When the current loop is active, the switch must be OFF.																												
Data Terminal Ready Disable During Parity Error (PAR DTR)	This switch allows the READY indicator and the Data Terminal Ready signal to be turned off when a parity error is detected in the incoming serial data. To enable this function, set the PAR DTR switch on (lever pointing toward the PAR DTR lettering). If a parity error occurs the interface removes the ready condition but continues to send and receive data. If parity errors should not affect the ready condition, set the switch off.																												
Carriage Return Delay Enable (NO CR)	This switch allows the reader to be delayed for a preset time when a predetermined ASCII control character (see Reader Stop or Delay Character Jumper description) is detected from the tape being read. This function serves as a delay for print-carriage return when the interface is feeding the serial port of a printer. To enable the delay, set the NO CR switch off (lever pointing away from NO CR lettering). The delay length is variable from 10ms to 1 sec by means of R23. The factory setting is 600ms. When the Carriage Return Delay is enabled, the automatic Reader Stop is disabled. To enable Reader Stop and disable Carriage Return Delay, set the NO CR switch on. In this position, the reader will stop after reading the ASCII control character described in the Reader Stop or Delay Character Jumper paragraph.																												
Reader Stop or Delay Character J5, J6, J7	The ASCII character used to enable the Carriage Return Delay is jumper-plug programmable on connectors J5, J6 and J7. The five least significant bits are accessible and are selected as follows: <table border="1" style="width: 100%; border-collapse: collapse;"> <thead> <tr> <th rowspan="2">Bit No.</th> <th colspan="2">Jumper Plug Location</th> <th rowspan="2">Bit No.</th> <th colspan="2">Jumper Plug Location</th> </tr> <tr> <th>True</th> <th>False</th> <th>True</th> <th>False</th> </tr> </thead> <tbody> <tr> <td>1 (LSB)</td> <td>J6-1 and J5-1</td> <td>J6-1 and J7-1</td> <td>3</td> <td>J6-3 and J5-3</td> <td>J6-3 and J7-3</td> </tr> <tr> <td>2</td> <td>J6-2 and J5-2</td> <td>J6-2 and J7-2</td> <td>4</td> <td>J6-4 and J5-4</td> <td>J6-4 and J7-4</td> </tr> <tr> <td></td> <td></td> <td></td> <td>5</td> <td>J6-5 and J5-5</td> <td>J6-5 and J7-5</td> </tr> </tbody> </table> To program an ASCII End of Text (ETX) character, place the jumper plugs as follows (this is the factory setting): J6-1 and J5-1, J6-2 and J5-2, J6-3 and J7-3, J6-4 and J7-4, J6-5 and J7-5. To program an ASCII Carriage Return (CR) character, place the jumper plugs as follows: J6-1 and J5-1, J6-2 and J7-2, J6-3 and J5-3, J6-4 and J5-4, J6-5 and J7-5.	Bit No.	Jumper Plug Location		Bit No.	Jumper Plug Location		True	False	True	False	1 (LSB)	J6-1 and J5-1	J6-1 and J7-1	3	J6-3 and J5-3	J6-3 and J7-3	2	J6-2 and J5-2	J6-2 and J7-2	4	J6-4 and J5-4	J6-4 and J7-4				5	J6-5 and J5-5	J6-5 and J7-5
Bit No.	Jumper Plug Location		Bit No.	Jumper Plug Location																									
	True	False		True	False																								
1 (LSB)	J6-1 and J5-1	J6-1 and J7-1	3	J6-3 and J5-3	J6-3 and J7-3																								
2	J6-2 and J5-2	J6-2 and J7-2	4	J6-4 and J5-4	J6-4 and J7-4																								
			5	J6-5 and J5-5	J6-5 and J7-5																								

- e. Input data is punched and echoed back to data source. Any port may be selected. Punch control may be local or remote. Reader is inactive.
- f. Model RJR2321 is controlled only by the READER switch. It has no remote control and no delay or stop character decoding. It has the Modem port only and no current loop.
- g. Model RJA2321 has the Modem port only. It does not have the TERMINAL, MODEM and MONITOR switches on the front panel. It has all the other features of the RJA2322.

See Section 3.5 for additional applications.

3.3.2 OPERATING PROCEDURE

Because of the many possible combinations of operating conditions only a general procedure and operating order is given.

- a. Connect the interface as described in Section 2.4.
- b. Place the board mounted switches and indicators in the desired positions. Table 3-3 lists the various control switches and their functions. Table 2-1 gives the factory setting for each switch. If different settings are required, perform Section 2.3.
- c. Place the POWER switch in the on position (lever up).
- d. Turn on power to the reader and punch.
- e. Make sure the READY indicator is lit. This indicates that the reader and punch are ready to communicate. If either the reader or the punch is not connected, the board-mounted RDR IN or PCH IN switches must be properly set. See Table 3-3.
- f. Select either remote or local control by depressing the REMOTE switch for remote control or by leaving the REMOTE switch out for local control. In remote control the reader and punch are controlled by seven ASCII characters; in local control, the reader and punch are controlled by front panel switches. This does not apply to model RJR2321.
- g. If the requirement exists that the incoming serial data be echoed back to the data source, depress the ECHO switch. The incoming data is punched but the reader is inactive since the output port is being used to echo. This does not apply to model RJR2321.
- h. Select either the current-loop port by depressing the TTY switch (not applicable to RJR2321) or one of the RS232C ports by depressing either the TERM (terminal), MODEM, or MONITOR switch. The TTY switch disables the RS232C input/output ports. If it is desired to select either TERM, MODEM or MONITOR, the TTY switch must be out. The ECHO switch must also be out when selecting MONITOR. Selection of MONITOR with the reader inactive routes the terminal output data to the Modem. Selection of MONITOR with the reader active routes the reader data to the Modem.
- i. Make sure the punch is loaded with tape. Load the tape to be read into the reader.
- j. If the interface is in local control (REMOTE switch out) and the incoming data is to be punched, depress the PUNCH switch.

- k. If the interface is in local control (REMOTE switch out) and the reader is to read tape, depress the READER switch. The reader will begin transmitting serialized data to the selected output port.

NOTE

The delay of the reader for a carriage return (when enabled by setting the NO CR switch off) is active in either the local or remote condition. However, the stopping of the reader on a stop code (when enabled by setting the NO CR switch on) is active only in the remote condition. To use the reader stop function in the local condition, depress the REMOTE switch while the reader is reading tape and before the stop code is read. The reader will now be stopped when the stop code is detected. To stop the reader under local control, release the READER button (a second push releases it).

The RJR 2321 is also stopped by releasing the READER button. This model has no remote control, no delay or stop character decoding.

- l. If the interface is in remote control (REMOTE switch in), the system is ready to be operated by the remote control signals. See Section 3.4 and Table 3-5.

3.4 REMOTE CONTROL SIGNALS

In remote mode, ASCII control characters are decoded by the interface and used to provide various control signals for the reader and punch. Table 3-5 lists the various control signals and their input codes as provided with the PROM in the standard unit.

3.5 ADDITIONAL APPLICATIONS

Due to the wide range of applications for serial communications links, additional modes of reader control beyond the classical RS-232-C specification have been included in the RJA2322 interface design. Each mode described in this section requires that the front panel switch settings be set to a special configuration.

3.5.1 REMOTE MODE READER/PUNCH START/STOP

The interface is designed to respond to the ASCII control characters described in Table 3-5. When an appropriate character is received and recognized, the interface commands the reader or punch to perform the appropriate function. ASCII control characters are masked and not punched with data received. The front panel switch "REMOTE" must be depressed and the on board switches, S9 and S10 must be in 7 or 8 bit format, LOCAL

Table 3-5. ASCII Control Characters

ASCII Character	Input Codes							Output Commands	Key Stroke
	B7	B6	B5	B4	B3	B2	B1		
DC1	0	0	1	0	0	0	1	Reader Run	C _Q
DC3	0	0	1	0	0	1	1	Reader Stop	C _S
DC2	0	0	1	0	0	1	0	Punch Run	C _R
DC4	0	0	1	0	1	0	0	Punch Stop	C _T
BS	0	0	0	1	0	0	0	Punch Back Space	C _H
STX	0	0	0	0	0	1	0	Reader Drive Right	C _B
EOT	0	0	0	0	1	0	0	Reader Drive Left	C _D

- NOTES: 1. C = Control Stroke
 2. The reader will automatically drive right unless DRIVE LEFT has been previously commanded.

MODE will cause I/O to ignore control characters sent. Punch Parity and Parity error checking is optional. One appropriate front panel port select switch "MODEM, TERMINAL, MONITOR or TTY" should be depressed.

NOTE

Front panel "READER" or "PUNCH" switch not being depressed will not inhibit an ASCII control character from controlling reader or punch operations.

3.5.2 REMOTE MODE-READER SINGLE STEP-ASCII DC1

In Remote Mode only, it is possible to step the READER one character every time a DC1 is transmitted to the interface. Switch settings must be per Section 3.5.1 with the addition of an on board jumper wire from test points Z to AA.

3.5.3 REMOTE MODE-PROGRAMMABLE READER STOP

In Remote Mode only, it is possible for the interface to stop the READER by a "Designated Character" read from punch tape. This character will be read and transmitted also. The "Designated Character" can be made up of any combination of Bits 1 thru 5 and, or Bit 8 and is selected per Table 3-6.

The on board switch "NO CR" S10-7 must be in the ON position. The interface is factory wired for ETX with "NO CR" on.

For ASCII End of Text (ETX) set on board jumpers as follows :

J6-1 to J5-1, J6-2 to J5-2, J6-3 to J7-3, J6-4 to J7-4, J6-5 to J7-5, J6-6 to J7-6.
(OCTAL CHARACTER 003)

Table 3-6. Reader Stop Character Select.

Bit Position	Jumper	Programmable Jumper		
		Hole	No Hole	
1 (LSB)	P5	J6-1 to	J5-1	J7-1
2	P6	J6-2 to	J5-2	J7-2
3	P7	J6-3 to	J5-3	J7-3
4	P8	J6-4 to	J5-4	J7-4
5	P9	J6-5 to	J5-5	J7-5
8 (MSB)	P10	J6-6 to	J5-6	J7-6

3.5.4 LOCAL MODE-PROGRAMMABLE READER DELAY

In LOCAL mode only it is possible for the interface to delay the next character to be read by 10 msec to 1 second after a "Designated Character" is read from punch tape and transmitted. On board potentiometer R23 adjusts the reader delay. Factory delay setting is 600 msec.

To select reader delay mode, set on board switch "NO CR" to its OFF position, select a character per Table 3-6, and set front panel switch "REMOTE" to its non depressed (local) position.

For ASCII character "CR" set jumpers as follows:

J6-1 to J5-1, J6-2 to J7-2, J6-3 to J5-3, J6-4 to J5-4, J6-5 to J7-5, J6-6 to J7-6.

3.5.5 LOCAL MODE READER SINGLE STEP (PICK INPUT)

In Local Mode it is possible to step the reader one character at a time (using either the Modem, or Current Loop Port) by using the "Pick" input signal on pin J1-25. The "Pick" signal is a TTL level signal and requires a separate signal line. A character from the reader is accessed and transmitted serially everytime the line is pulsed low (0 volts) provided that the board mounted switch marked "No Pick" is in the OFF position. If the current loop port is employed be sure to include logic ground ("Pick" signal return) J1-7 in your cable. J1-25 and J1-7 should be a twisted pair.

The "Pick" signal must be a pulse of 20 to 50 microseconds width for the reader to stop on a desired character. If the "Pick" signal remains LOW (OV) the reader will enter synchronous mode.

3.5.6 LOCAL or REMOTE MODE - CLEAR to SEND (CTS) START/STOP

In local mode it is possible to start and stop the reader remotely when in other than ASCII format when using the RS-232-C ports. This is accomplished by raising CTS (Clear To Send) to start a read operation and lowering CTS to stop reading. This operation requires CTS to be wired through to the Modem or Data Set device and setting board mounted switch "CTS EXT" (S10-5) to the ON position. This feature will work in REMOTE MODE after a cycle has been initiated with DC1. CTS must be low when DC1 is received, then taken high to start reader.

3.5.7 LOCAL MODE - PUNCH START/STOP

In Local Mode, while operating via the RS232 ports J1 and J2, the punch is brought "on line" by depressing the "PUNCH" push button on the front panel. If during punching a failure occurs in the punch, DTR will go false signaling the transmitting device to stop sending (Refer to Figure 3-1 for typical connections).

NOTE

When the on board switch "Parity DTR" is in its ON position, DTR may also be dropped due to a parity

error. The interface will continue to send and receive in this condition expecting the transmitting device to cease transmission. The front panel "Ready" indicator will extinguish - flagging the operator of an error condition.

3.6 TYPICAL CONFIGURATIONS OF HOOKUP

3.6.1 MODEM PORT - RS - 232 - C

Typical use of the RJA2322 interface via the modem port is depicted in Figure 3-1. The term "Modem Port" (J1) signifies connection to a modem or data communications equipment and is wired to use straight through cables. This port is generally used for single ended Reader/Punch terminal applications.

3.6.2 TERMINAL PORT - RS - 232 - C

Typical use of the RJA2322 interface via the terminal port is depicted in Figure 3-2. The term "Terminal Port" (J2) signifies connection to a terminal or data terminal equipment and is wired with TRANSMIT DATA and RECEIVED DATA interchanged (pins J2-2 and 3) as compared to MODEM Port (J1). Reference Table 3-1).

3.6.3 MODEM AND TERMINAL PORT - RS - 232 - C

Typical use of the RJA2322 interface using the full complement of ports available is depicted in Figure 3-3.

Depressing the front panel "MONITOR" switch allows the interface Terminal Port (J2) to monitor the Modem Port (J1). Refer to Table 3-4. Information received on the Modem Port can be punched and also transmitted out the Terminal Port to a CRT or printer, etc. In local mode, the front panel "PUNCH" switch must be depressed to activate punch. Information transmitted into the Terminal Port via a keyboard terminal, etc. will be sent out the Modem Port. Reader data will also be transmitted out the Modem Port. In local mode, the front panel "READER" switch must be depressed to activate reader along with proper CTS and DSR conditions (Ref. 3.5.6).

CAUTION

When using Monitor Mode, the key board or terminal device on the terminal port (J2) should not be operated while punch tape is being read. Both devices can simultaneously transmit out the modem port resulting in scrambled data.

3.6.4 CURRENT LOOP OPERATION

Typical use of the 20 mA current loop interface is depicted in Figure 3-4. Separate loops are required for transmitting and receiving data. Each loop requires a twisted pair

of wires. Although current loop circuits exhibit excellent noise immunity, shielded twisted pair is recommended in high electrical noise environments and long distances, typically over several hundred feet.

3.6.4.1 Current Loop Modification to External (Loop Source)

The interface is factory wired for 20 mA internal loop source and may easily be modified to external loop source by on board jumpers as follows:

NOTE

Either loop may be internal or external loop wired independently.

- o Receive Loop Change to External
Delete Jumpers: U to T, W to V
Install Jumpers: T to V
- o Transmit Loop Change to External:
Delete Jumpers: FF to DD, CC to EE
Install Jumpers: CC to DD

3.6.4.2 Current Loop Modification to 60 mA

The interface is wired for a nominal 20 mA current loop. In applications where a 60 mA loop is required, or where line voltage drops make the loop non-functional, the line current may be boosted by replacing resistors as follows:

- o Receive Loop Change to 60mA
Change R7 and R9 to 82 ohms, 1/4 WATT
- o Transmit Loop Change to 60 mA
Change R27 to 180 ohms, 1/2 WATT

3.7 SPECIAL FEATURES

3.7.1 ECHO FEATURE

Depressing the front panel "ECHO" switch and one of the serial port switches allows serial information received on that port to be routed back to the source as processed by the interface. This feature can work in current loop and RS - 232 - C modes.

3.7.2 READER INTERCHARACTER DELAY

The time between each character transmitted serially from the reader can be delayed a selectable time from 70 microseconds to 1 millisecond. Intercharacter delay should be adjusted to exceed the time required by the host processor to interrogate a transmitted character and decide if it wants to stop on that character. If the decision is yes, the host processor would drop CTS. The delay is customer selectable by on board potentiometer R30 if the on board jumper A1 to A2 is deleted and jumper A2 to A3 installed.

3.8 SPECIAL CAUTIONS

3.8.1 "X ON" AND "X OFF" TERMINOLOGY

The common industry terminology of "X ON" and "X OFF" are not entirely synonymous to DC1 and DC3 (Reader) or DC2 and DC4 (Punch) as supported by the RJA2322 interface. The RJA2322 responds to the ASCII control character set as a "Terminal" and does not generate "X ON" or "X OFF" characters for transmission to control other serial devices.

3.8.2 CHARACTER BUFFERING READER

In remote applications where characters such as Block Codes or Stop Codes, etc. are read off the punched tape and then processed by the system to generate a DC3 (Reader STOP), care must be taken to maintain a buffer of sufficient size to handle data transmitted during system turn around time, if intercharacter delay time as described in Section 3.7.2 is insufficient.

System turn around time is affected by transmission rates, modems, line drivers, telephone system link up, character recognition and processing time by the system intelligence.

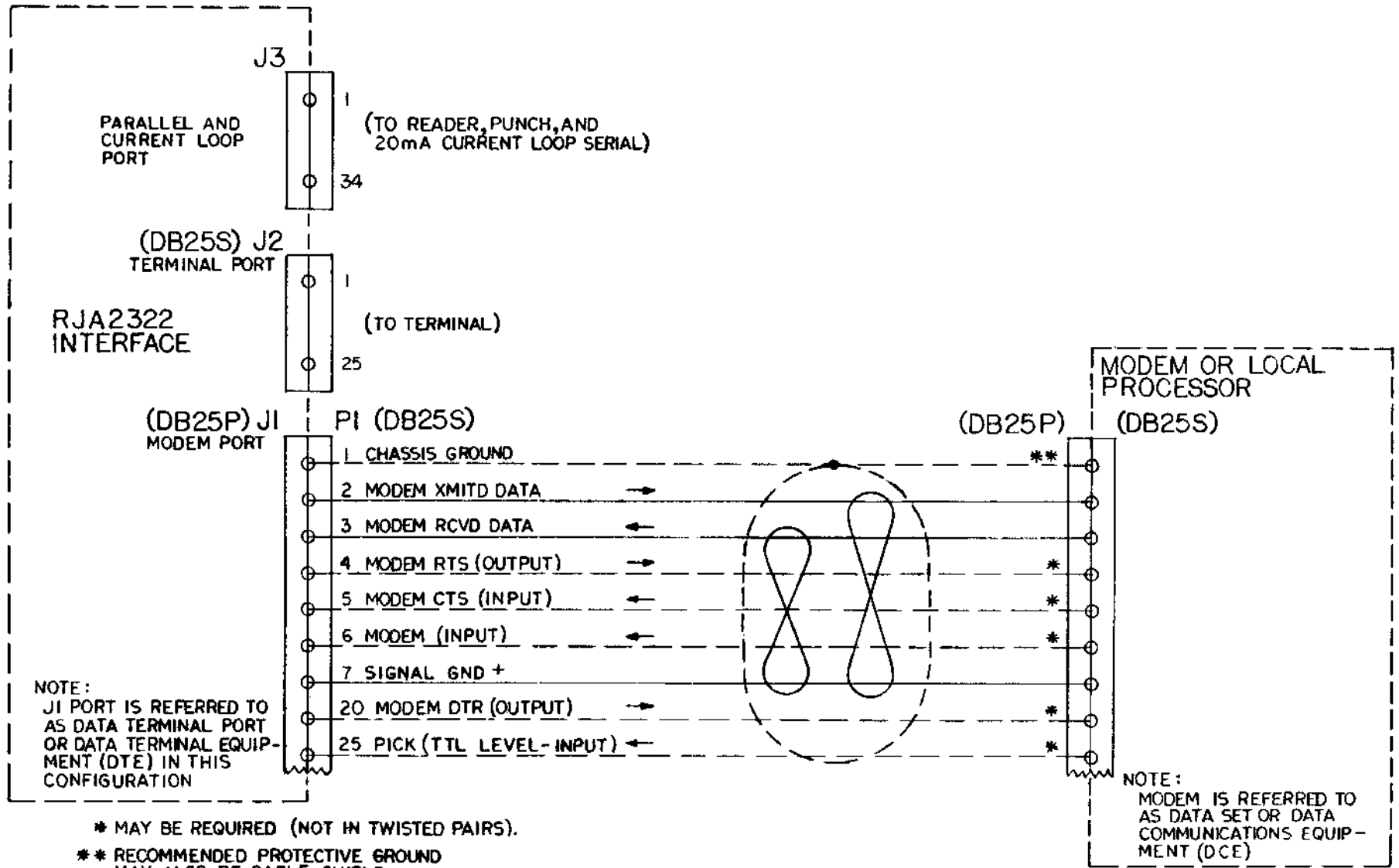

MMC 741

Figure 3-1. Modem or Local Processor to Reader and Punch RS - 232 - C Connections.

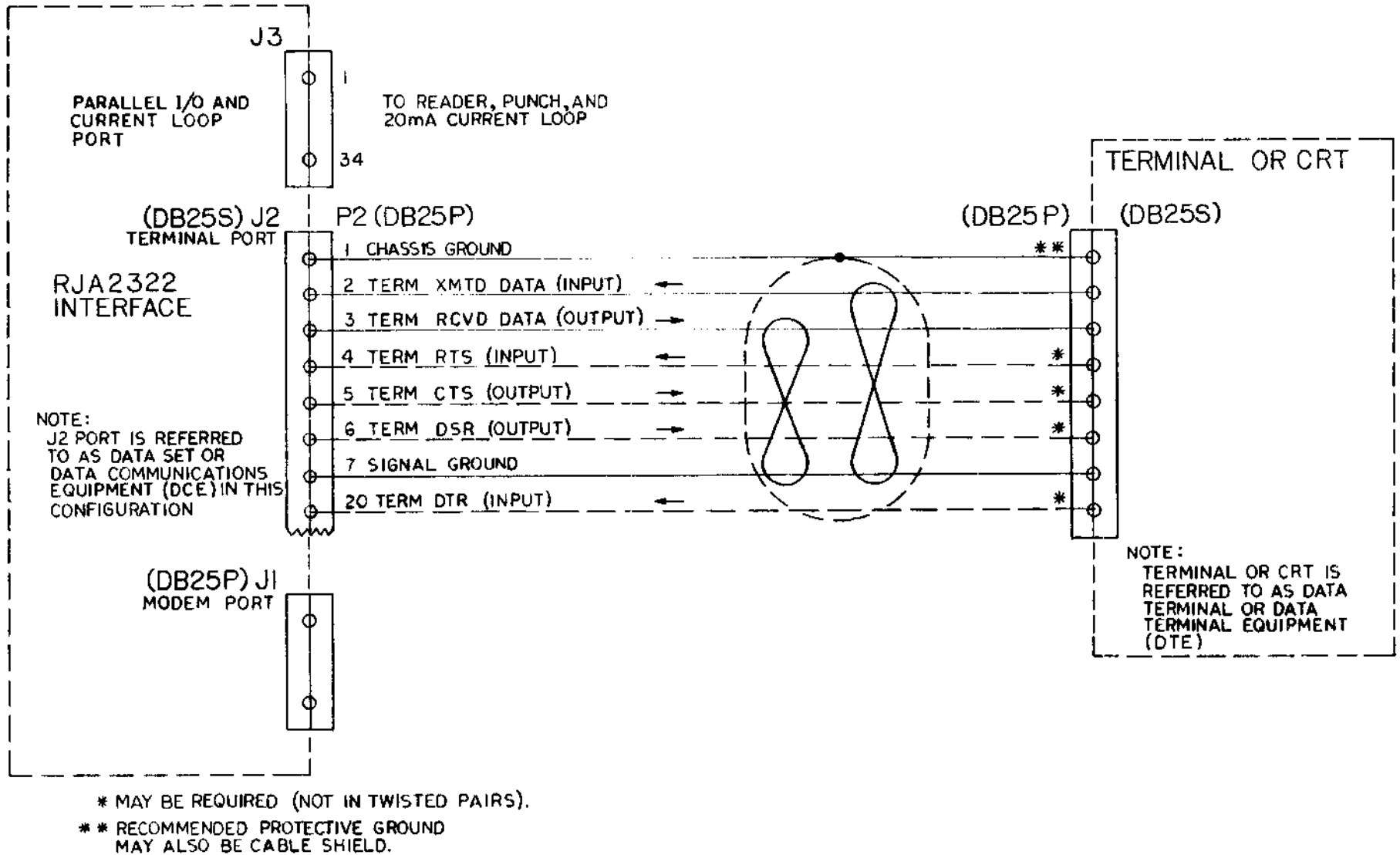
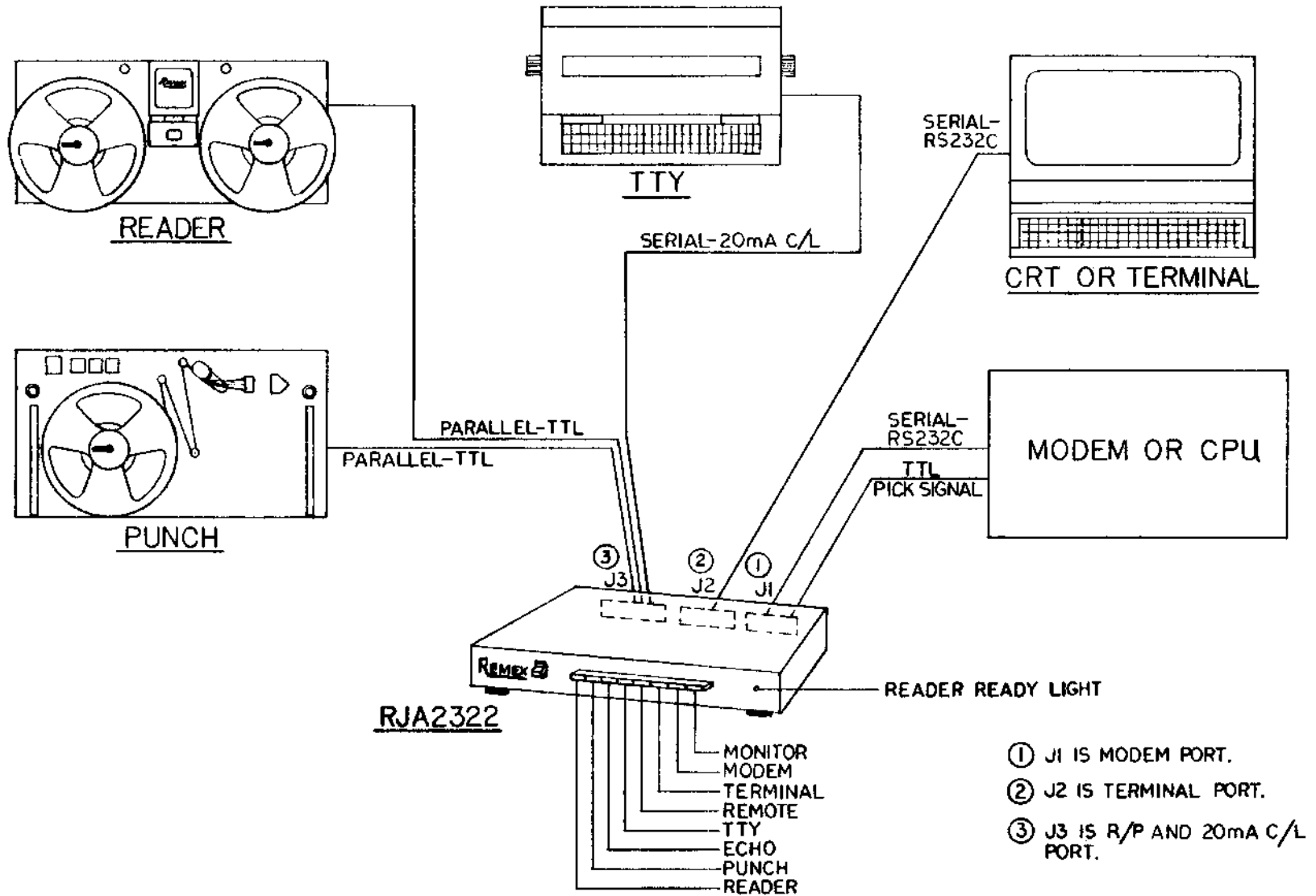
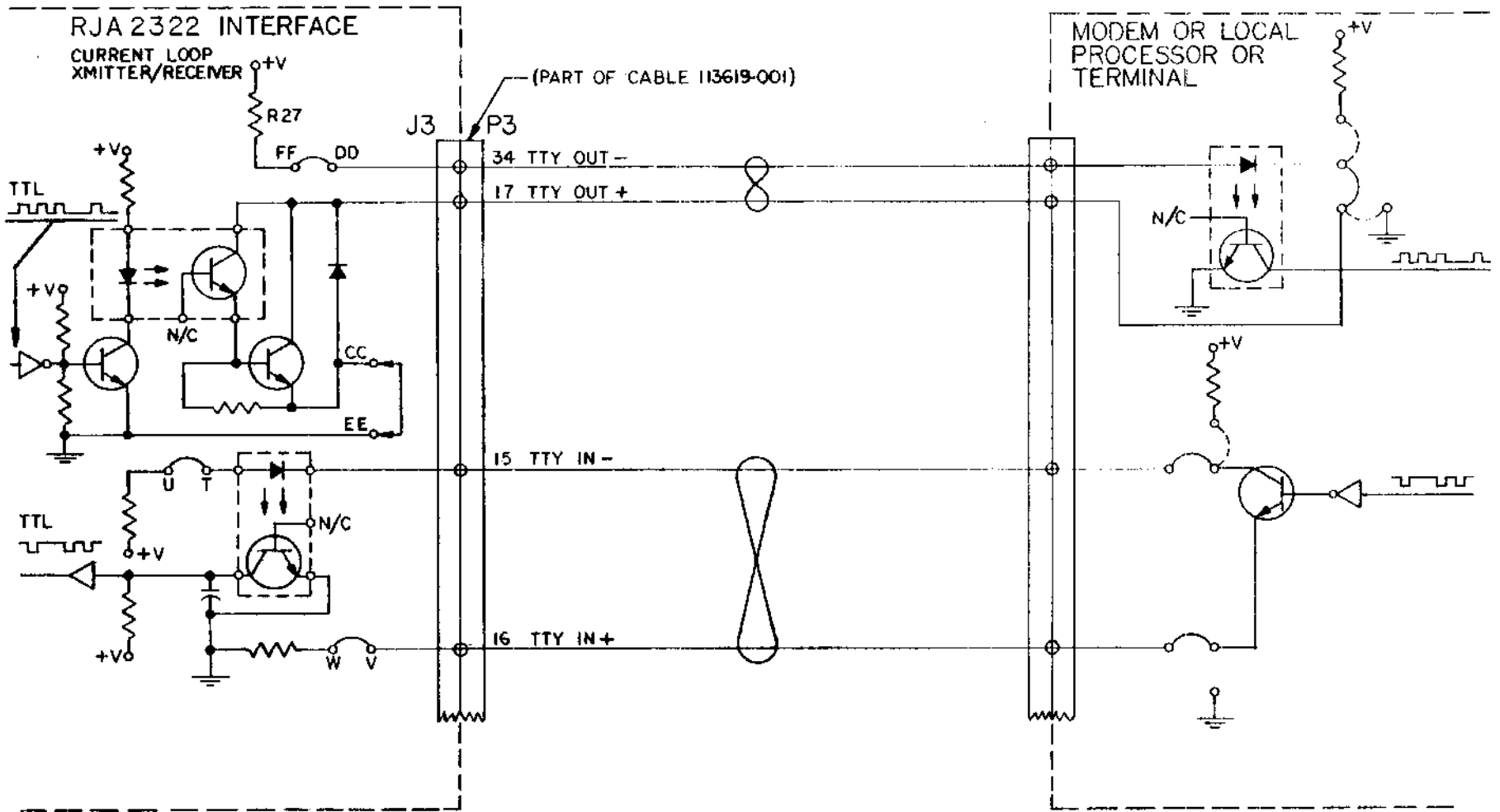

Figure 3-2. Terminal or CRT to Reader and Punch RS - 232 - C Connections.



MMC 743

Figure 3-3. Typical Multidevice System Configuration
RS - 232 - C and Current Loop Connections.



MMC 744

Figure 3-4. Typical Serial Connection
20 mA Current Loop.

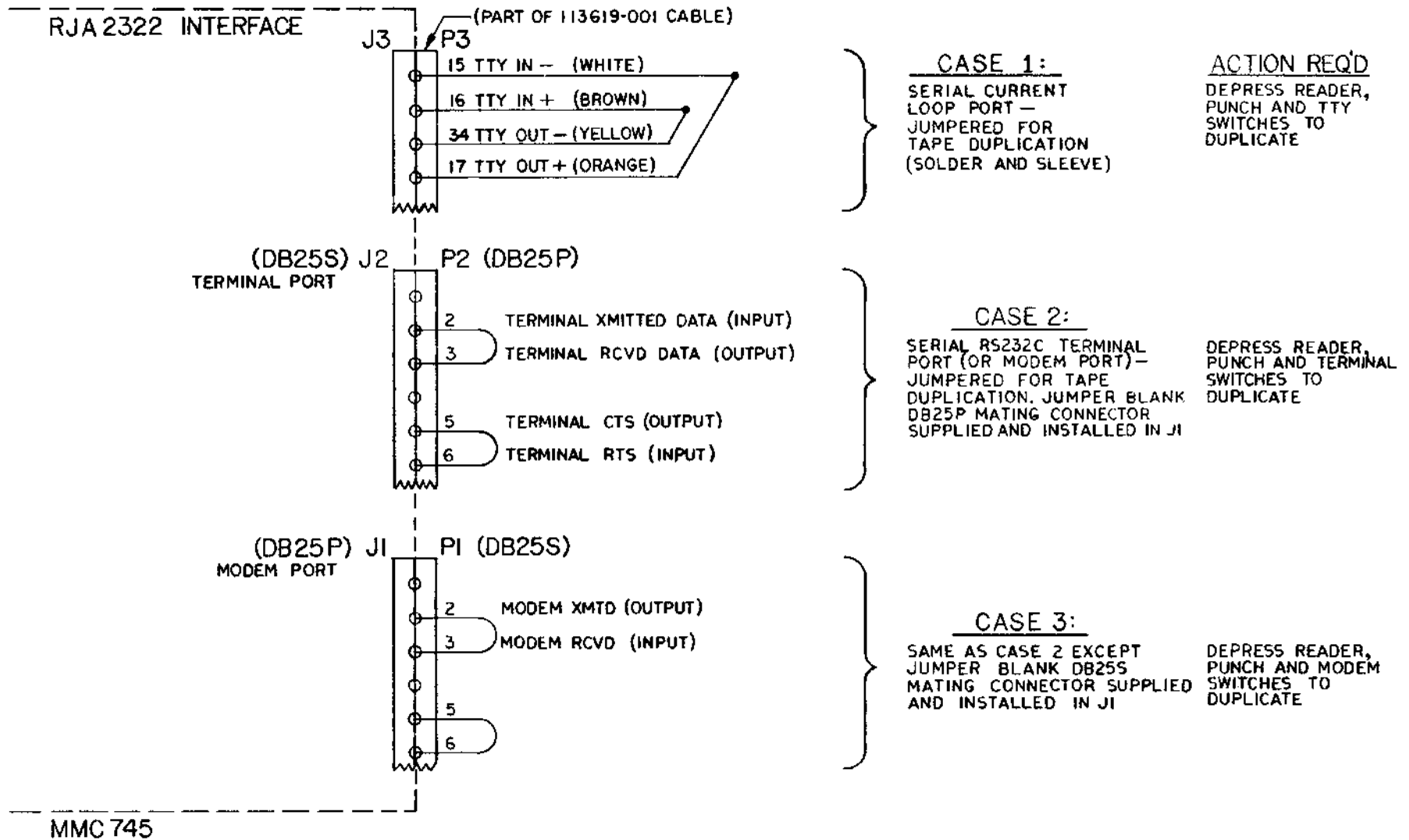

Figure 3-5. Spare Port Jumpering For Tape Duplication.

SECTION IV

THEORY OF OPERATION

4.1 MODEL DIFFERENCES

The theory of operation which is covered in both block diagram and circuit description form is described for the RJA2322 since it is the most complex unit of the three models. The RJA2321 is similar but with the elimination of the terminal port and its associated logic and the RJR2321 is also similar but with the elimination of the terminal port, current loop and punch. See Section 1.1 for the description of the model differences. Areas on the schematic which are not common to all three models are blocked in and identified with numbers referring back to notes on sheet 1 of the schematic.

4.2 BLOCK DIAGRAM

Before starting to analyze the block diagram, the reader should review the various modes of operation. See Section 3.3.1. Figure 4-1 gives the block diagram for RJA2322. Models RJA2321 and RJR2321 are similar except for the removal of certain features as described in Section 4.1. Table 4-2 at the end of Section IV lists the signal mnemonics used on both the block diagram and the schematic. P.C. Card 113771 contains the entire circuitry for the Interface. The following major functions are performed by the RJA2322:

- (1) RS232C handshake interchange.
- (2) Data flow from the reader to any of three ports,
- (3) Data flow from any of the three ports to the punch,
- (4) Communication between the terminal port device and the modem port device with the punch monitoring the data,
- (5) Input data is punched and echoed back to data source,
- (6) Incoming codes are detected and decoded for use in reader and punch control and
- (7) Miscellaneous control logic circuits.

4.2.1 RS232C HANDSHAKE SEQUENCE

To provide for an orderly flow of information, the RS232C Specification lists certain signal interchange sequences to be performed. The sequence depends upon whether the Interface is sending or receiving and whether the communication is with the modem or the terminal. Table 4-1 lists the sequence of events for each of the four possible communication situations.

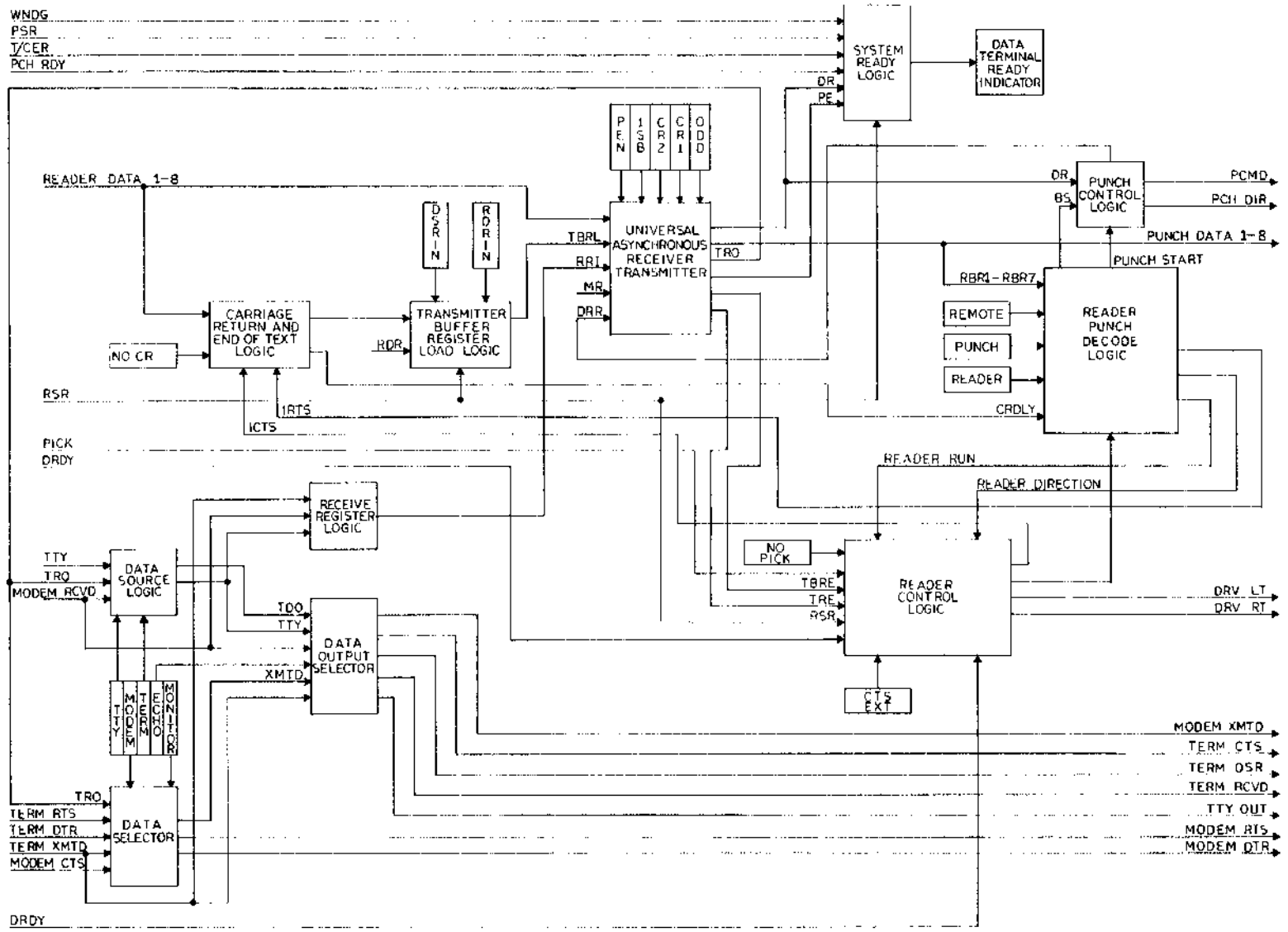

MMC 639

Figure 4-1. Block Diagram for the RJA2322.

Table 4-1. RS232 Sequence

Communication Direction	Data Exchange Sequence
1. Terminal to Interface.	When power is first turned on: <ul style="list-style-type: none"> (a) TERM DTR from terminal goes true, (b) DSR from interface goes true When terminal is ready to send: <ul style="list-style-type: none"> (c) Terminal issues RTS (d) Interface responds with TERM CTS if it is ready. (e) Terminal sends data over TERM XMTD* line.
2. Interface to Terminal	Interface looks for TERM DTR. If true sends out data over TERM RCVD* line.
3. Modem to Interface.	Modem looks for MODEM DTR. If true sends out data over MODEM RCVD* line.
4. Interface to Modem	When power is first turned on <ul style="list-style-type: none"> (a) MODEM DTR from interface goes true, (b) Modem has MODEM CTS off. (c) Modem has MODEM DSR on. When interface is ready to send: <ul style="list-style-type: none"> (a) Interface issues a true MODEM RTS (b) Modem responds with MODEM CTS if ready. (c) Interface sends data out MODEM XMTD* line.

4.2.2 DATA FLOW FROM READER

Data from the reader is applied to J3 on eight parallel input lines (RDTA 1-8) which terminate at the Universal Asynchronous Receiver Transmitter (UART) which converts the parallel data into serial data and inserts the necessary start, stop and parity bits into the serial data. The serial output at TRO is applied to both the Data Source logic and the Data Selector. If the modem port is in operation, the data is selected through XMTD and sent out the Modem Transmitted line (MXMTD). If the terminal is in operation, the data is selected by means of the TD0 line and sent out the Terminal Received line (TRCVD). Similarly if TTY is selected, data is gated with the TTY signal and sent out the TTY OUT line.

4.2.3 EXTERNAL DATA FLOW IN

External data can be received from three sources: TTY (TTY IN), terminal (TERM XMTD) or modem (MODEM RCVD*). Depending upon the selected front panel switch (TTY, TERM or MODEM), the corresponding serial input data will be selected by the Receive Register logic and applied to the Receive Register In (RRI) terminal at the UART. The UART converts serial start, data, parity and stop bits into parallel data, verifying proper code transmission, parity and stop bits.

Five switches control the input function to the UART. Switches CL1 and CL2 are used to select the character length. Switch 1SB selects the stop bits. Switch PEN permits parity checking. The fifth switch is ODD and it selects even or odd parity.

UART outputs consist of RBR1 through RBR8 which are the contents of the receiver Buffer Register. When a character has been received, the Data Received (DR) output goes true which is used to enable the punch. At the next punch clock, the punch command (PCMD) is generated causing the data on RBR1-RBR8 to be punched.

4.2.4 MODEM AND TERMINAL PORTS COMMUNICATION

In monitor mode (MONITOR switch depressed) the interface allows data from the modem to be channeled to the terminal and vice versa. Data from the modem is applied to the Data Source Logic where it is gated with the MONITOR switch signal and produces the TDO signal. This is then applied to the Data Output Selector which transfers the serial data to the Terminal Received Data (TERM RCVD*) line.

Similarly the data from the terminal (TERM XMTD) is applied to the Data Selector where it is gated with the MONITOR switch signal and applied to the XMTD output. This signal is then gated at the Data Output Selector and applied to the Modem Transmit Data line (MODEM XMTD). The data also follows the path outlined in paragraph 4.2.3 to produce the RRI signal and subsequently the parallel data signals to the punch.

4.2.5 ECHO MODE OPERATION

In Echo mode the ECHO switch is depressed and the interface selects the incoming data as described in Section 4.2.3 and punches it. In addition the ECHO switch gates incoming data at the Data Output Selector and transmits it back to the source. For example, data received on the MODEM RCVD* line is transmitted back to the modem on the MODEM XMTD* line. The input data is also received by Receive Register logic and, in turn, applied to the UART and finally to the punch if selected.

4.2.6 CODE DETECTION

Data from both the reader and serial sources contains coded commands which are used to operate the reader and punch and provide the carriage return and end of text signals. Parallel reader data is not only applied to the UART but is also gated at the carriage return and end of text logic. Any combination of bits 1-5 can be programmed to select the End of Text (ETX) code. When the ETX is detected, a one-shot is triggered and its output is used to inhibit the reader logic. The one-shot is adjustable from 10 ms to 1 sec to provide for a wide range of applications.

Parallel outputs RBRI-RBR7 from the UART are also applied to the Reader-Punch Decode logic. It is the purpose of this logic to decode the seven ASCII control characters listed in Table 3-5. These commands include reader run/stop, reader direction, punch start/stop and punch back space. The decoded signals are then applied to the reader and punch control logic sections.

4.2.7 READER/PUNCH CONTROL

The reader control logic is operated primarily by the signals generated from the Reader/Punch Decode logic. This section generates the drive left and drive right signals. It also converts the Pick* input into a drive signal which steps the reader one line at a rate not to exceed the reader baud rate. When the Pick* signal is not used, the circuit is stepped at the character rate determined by the transmit baud-rate setting (J8, J9). The transmitter Buffer Register Empty (TBRE) signal from the UART indicates the UART is ready to receive a new line of information. TBRE is used to generate the next reader step command.

When the data from the reader is ready to be read-in, the Data Ready (DRDY) line from the reader is true. This generates a sequence of events which results in the Transmitter Buffer Register Load (TBRL*) signal going true, provided the Carriage Return Delay (CRDLY*), if present, has timed out. TBRL* signals the UART to load the waiting line of data.

The punch control logic section uses the Back Space (BS), the Remote (REM) and the Data Received (DR) signals to generate the punch direction. The DR signal along with the Punch Clock (PCLK) is used to produce the Punch Command (PCMD) signal.

4.2.8 SYSTEM READY LOGIC

System ready is indicated by the Data Terminal Ready indicator. The system ready logic uses the Winding (WNDG*), Reader System Ready (RSR), Punch System Ready (PCH RDY), Tape Chad Error (T/CER), and the Parity Error (PE) signals all combined in various gates to turn on the Data Terminal Ready indicator. If the PAR DTR switch is off, then the PE signal has no effect on Data Terminal Ready. Another signal, Data Received (DR) from the UART is also applied to this logic to produce a simulated punch ready signal during punching time (PCH RDY is false during punching).

4.3 CIRCUIT DESCRIPTIONS

The following paragraphs describe the operation of the circuits which comprise the 113771 Interface Card. Section VIII contains the schematics for the interface card. The power supply is also contained on this drawing (sheet 5). Circuit areas described in the text are referenced to the schematic by sheet number (1 through 5) and zone coordinates on the sheet. For example, the location of the Data Terminal Ready Indication would be referenced as 5D3, i.e., sheet 5, zone D3.

Table 4-2 lists the various mnemonics used to identify the data and control lines and gives their full name, origin (sheet and zone coordinates) and a brief description of their function. Sheet 1 also lists some of the mnemonics and where they are used (those with multiple usage). Also contained on sheet 1 is the jumper wire list as it applies to the various dash numbers.

I.C. packages are designated by a number and then a letter. For example, the 1M6402A on sheet 2 is designated 6B. The number and letter identify its physical location on the circuit card by specifying its coordinates. The number denotes the vertical column and the letter denotes the horizontal row, both of which are printed on the Interface card. Thus 6B describes an I.C. device located in column 6, row B. In the text these references are always preceded by a Z as in Z6B. If a dash number follows, it indicates a particular pin on that device.

Most of the I.C. devices used on the card are CMOS. As indicated in the notes on sheet 1 of the schematic, most of these devices use +8 Vdc. Since much of the input signals are TTL logic, these are fed into a level shifting circuit which makes them CMOS compatible. Similarly, when going out, the CMOS signals are also buffered to make them TTL compatible. Exceptions, of course, are the TTY signals which are set up for current loop operation. See Table 3-1 for the voltage and current levels of the input and output signals.

4.3.1 SYSTEM CLOCK CIRCUITS

A 16 X clock rates developed by a frequency divider circuit Z3C (5E5) with the use of controlling crystal Y1. The clock rate for the reader (RCLK) is selected by jumpering J8 and J9 with P10 at the appropriate pin depending upon the baud rate required. P11 is used to jumper J10 and J11 to select the punch clock (PCLK) rate. Z7E, R14, Z1C and R13 are used to convert the +5V clock level output to a +8V level which is CMOS compatible. RCLK and PCLK and their inverted signals are used as timing signals throughout the interface.

4.3.2 UART DESCRIPTION

I.C. package Z6B (2D5) is a 1M6402A Universal Asynchronous Receiver Transmitter (UART) which performs parallel to serial and serial to parallel data conversion. Inputs DB1 - DB8 receive the parallel input data. When the Transmitter Buffer Register Load (TBRL*) signal goes low, parallel data is loaded into the UART. Inside it is converted to serial form which contains the start, data, parity and stop bits in the proper sequence. The serial output then appears at the Transmitter Register output (TRO) pin.

The Receive Register Input (RRI) pin is used to receive serial data which is then converted to parallel data and appears at outputs RB1 - RB8 which are the contents of the Receiver Buffer register. These outputs are buffered and sent directly to the punch (PDTA1 - PDTA8). They are also used by the decode logic as described in Section 4.3.8. Word formats less than 8 characters are right justified to RB1. Output DR (Z6B-19) when high indicates a character has been received and transferred to the receiver buffer register. The UART also verifies proper code transmission and parity and stop bits.

Five switches control the input functions to the UART. Switches CL1 and CL2 (2C4) are used to select the character length as given in Table 3-2. Switch 1SB selects the stop bits. When open, the 1.5 stop bit for 5 characters is selected and 2 stop bits for other lengths. When 1SB is closed, one stop bit is selected. Switch PEN permits parity checking when the switch is closed and inhibits parity checking when open. The fifth switch is ODD which is closed when selecting odd parity and open when selecting even parity.

A high level on PE (Z6B-13) signifies that the parity does not match the parity selected by PEN and ODD switches. This output is low when PEN is open. Data Ready Reset (DRR*) is an input (low true) which clears the data received (DR) output. When DR goes high and the next PCLK is received at Z3B, pins 5 and 6 (3D4), DRR* goes low and is applied to Z6B-18 (2D6) and clears DR. Master Reset (MR) at pin 21 is applied when power is first turned on and is generated at Z2C-6 (2B4). MR and MR* are also used to initially reset various other logic functions on the Interface Card.

When data has been received and transferred to the receiver buffer register in the UART, output DR (Z6B-19) goes high. This signal is used with the punch check (PCLK*) signal to trigger the Punch Command flip-flop at Z1D-11 as described in Section 4.3.10, Punch Control Logic.

4.3.3 RS232 HANDSHAKE LOGIC

Table 4-1 summarizes the handshake sequences which occur before data is actually transmitted. The following four descriptions are based on the four communication directions given in the table.

4.3.3.1 Terminal to Interface

When power is first turned on, the TERM DTR signal at J2-20 (4D8) goes true. This signal is gated at Z5E, pins 8 and 9 with the internal TERM signal from the selected Terminal (TERM) Switch to produce the Data Set Ready (DSR*) signal. DSR is used in conjunction with the TBRL logic as described in Section 4.3.3.2 and 4.3.12. Readiness by the interface is indicated by the Internal Data Terminal Ready (IDTR) being true. See Section 4.3.13. IDTR is gated at Z2F-2 with the TERM signal to give the Terminal Data Set Ready (TDSR) at Z4G-4 and subsequently at J2-6. When the terminal sets its Request to Send line (TERM RTS) at J2-4 true, it is gated with the previously described TDSR at Z6G, pin 5 and 6 which result in the Terminal Clear to Send (TCTS) going true at J2-5. Upon receipt of the TCTS signal, the terminal will begin sending data when it is ready. This data is received at TERM XMTD*, J2-2. The internal flow of data from this point is described in Section 4.3.5.

4.3.3.2 Interface to Terminal

To send data from the interface to the terminal, the only signal required is the true TERM DTR which generates the DSR* (4C6) signal as described in Section 4.3.3.1. DSR* is one of four conditional signals applied to the Transmitter Buffer Register Load (TBRL) logic at Z7F-5 (2A5). The other signals are the Reader System Ready (RSR), Internal Clear to Send (ICTS) and Internal Request to Send (IRTS). When the Interface is ready to send, the Reader Run signal from Z4D-13 (3D3) is gated with the Data Ready Signal (DRDY) at Z4E, pins 8 and 9 to give the true Word Ready (WDRDY) signal at Z4E-10. This signal is gated with the Carriage Return Delay (if used) at Z1E-9 (2B1), and if the signal is false (high) the output enables the TBRL flip-flop at Z2D-9 (2A5). The next Reader Clock (RCLK*) sets the F/F causing the Q output at Z2D-13 (2A4) to go high and TBRL* to go low. At the next clock Z2D-2 goes low and TBRL* goes high. It is the positive going edge which loads the parallel data into the UART. Data is then transmitted out via the TRO line as described in Section 4.3.5.

4.3.3.3 Modem to Interface

In this mode of communication flow, the modem looks for the true MODEM DTR signal at J1-2. This signal is generated when the IDTR signal is true at Z8G-4 (4E5) and MODEM is selected (MOD term true, at Z8G-9). When the modem sees the true DTR and is ready to transmit, it begins sending serial data out the MODEM RCVD line which appears at the interface at J2-3. The internal flow of data from this point is described in Section 4.3.5.

4.3.3.4 Interface to Modem

When the IDTR signal comes true and the modem is selected (MOD true) the MDTR signal at Z8G-11 (4D5) is true and is sent out to the modem at J1-20. During this time, the MODEM CTS signal at J1-5 is false. When the Interface is ready to send, the Reader Run signal from Z4D-13 (3D3) is gated with the Data Ready (DRDY) signal at Z4E, pins 8 and 9 (3B7) to give the true Word Ready (WDRDY) signal at Z4E-10. This signal, in turn, is combined with either the false output of Z5G-4 (MCTS is false at this time) or the Switched Request to Send (SWRTS) from the CTS EXT switch to give the Set Request to Send signal (SRTS*). SRTS*, in turn, sets the 4-bit latch at Z4D-11 and generates the true IRTS signal. IRTS is applied to Z8G-6 (4E6) where it is sent out the MODEM RTS line at J1-4.

The modem then responds with the true MODEM CTS at J1-5 (4D8). MCTS is gated with MM/T at Z5G, pins 5 and 6 (3C8) to give the true ICTS signal. ICTS is then gated with four other signals (2A5) at TBRL logic and data is sent out as described in Section 4.3.3.2. TBRL* then triggers the UART causing data to be transmitted out the TRO line as described in Section 4.3.5. If the modem is not equipped to send a MODEM CTS signal, the CTS EXT switch (3C8) must be in the open position to simulate the receipt of this signal. The switch is closed if the modem is equipped to send this signal.

4.3.4 DATA FLOW FROM READER

Parallel data from the reader is applied to the UART on input lines DB1-DB8 (2E6, 2D6). This data is also applied to the carriage return logic as described in Section 4.3.11 for End of Text (ETX*) decoding. A level shifting circuit composed of a 10K and a 2.2K resistor along with a 74C906 inverter (Z8A, Z8B) converts the reader outputs to a level compatible with CMOS circuitry. Serial data is generated by the UART and appears at the TRO output, Z6B-25 (2D5). The TRO signal is applied three places: (1) to the data selector chip Z8G-2 (4D6) at the A₂ input. If either Modem or both monitor and reader run are selected (Z8G-9 true), the data appears at Z8G-12 (XMTD line). XMTD is, in turn, applied to the data selector chip Z7G-7 where it is sent out the Modem Transmit line at J1-2, provided ECHO is not selected. Note that the output lines of Z7G (Z₀-Z₂) are selected from the A₀-A₂ inputs if ECHO is selected or from B₀-B₂ if ECHO is not selected; (2) TRO is gated with the Terminal signal at Z5F, pins 12 and 13 (4C5) to generate the Transmit Data Out (TDO) signal, provided the TERMINAL switch is selected. TDO is applied to the data selector chip Z7G-5 where it is sent out the TERM RCVD* line at J2-3 provided ECHO is not selected; (3) TRO also is applied directly to Z7G-3 where it is sent out the TTY line, provided ECHO is not selected. It can thus be seen from Z7G that if ECHO is not selected, the serial data will go out the terminal line if TERMINAL is selected or out the modem line if either Modem or both Monitor and Reader Run are selected and always out the TTY line.

4.3.5 DATA FLOW FROM TERMINAL, MODEM OR TTY

Data from a terminal is received at the TERM XMTD* input at J2-2 and is applied two places: (1) to data selector Z8G-3 (4D5) where it is selected if the Interface is in monitor mode and then sent to data selector Z7G where it is routed to the MXMTD line provided ECHO has not been selected; (2) TERM XMTD* is also applied to the Register Receive Logic at Z5F-5 (4B5) where it is gated with either the TERM signal to generate the Serial Data In (SDI*) signal. Since TTY is not selected, the data will then appear on the Receive Register In line (RRI) and be sent to the UART at pin 20 (2D6).

The MODEM RCVD* line is used to receive the data from the modem at J1-3 and is applied three places: (1) it is gated with the Modem/Monitor signal (MM/T) at Z5F pins 1 and 2 and sent through the TDO line and out on the TERM RCVD* line, (2) it is applied to pin 6 of Z7G and selected as the output to the MODEM XMTD line when the Interface is in ECHO mode, (3) it is sent to the Receiver Register In logic at Z5F-8 when it is gated with the MM/T signal to become SDI* and in turn, the RRI input to the UART. It should be pointed out that the MM/T signal is generated at Z4G-11 (4C7) and indicates either the MODEM or the MONITOR switch has been selected. This signal is described in detail in Section 4.3.6.

The third input source is the TTY or the current loop source. When TTY is selected, current flows through R7 and J3-15 which turns on Z9 and places 0V at Z6E-11. This is also applied to Z5E-12 where it is gated with the TTY switch signal and sent to the UART via the RRI input. At Z6E-11 the input is inverted and gated at the Data Selector Logic Z7G-2 where it is sent out the TTY OUT line when the interface is in ECHO mode.

4.3.6 MONITOR MODE

The MONITOR switch itself has no logic contacts. It does release the MODEM and TERM pushbuttons causing two NO contacts on these switches to be gated at Z1E pins 3-5 to give the Monitor (M/T) signal (4B1). This signal is used three places: it is applied to Z8G-14 to select the B₀-B₃ inputs to Z8G. In monitor mode the TERM RTS signal is switched to the MODEM RTS line, (J1-4) the TERM DTR is switched to the MODEM DTR line (J1-20), the TERM XMDT* input data line is switched to the XMTD and subsequently switched to the MODEM XMTD output at J1-2, and the MODEM CTS line is switched to the TERM CTS output at J2-5; (2) it is gated at Z4G-13 (4C7) to give a monitor or modem signal (MM/T) at Z4G-11 which then gates the MODEM RCVD input at Z5F-1 (4C5) and also the MODEM DSR signal at Z2F-8 (4C5). The usage of these signals are described in other sections; (4) MM/T also gates the MODEM RCVD* data at Z5F-9 (4B5) so that during monitor, the modem input data will appear on the RRI input line to the UART and, in turn, be punched.

4.3.7 ECHO MODE

In Echo mode the ECHO switch is depressed causing the ECHO signal (4C1) to be true. The ECHO signal is used at Z7G-9 (4B4) to switch the following three lines: (1) the MRCVD data from the modem back to the MODEM XMTD line; (2) the TXMTD data from the terminal back to the TRCVD line; and (3) the TTY + input data from the TTY back out

the TTY OUT + line. Thus echo mode allows the incoming data to be echoed back to its selected source. The data is also applied to the UART via the RRI input (see Section 4.3.6) so that the incoming data can be punched if desired.

4.3.8 CODE DETECTION

Outputs RBR1-RBR5 from the UART contain coded information which is used to operate the reader and punch. These input lines are applied to a pre-programmed PROM, Z5C (3E7) in which they are decoded into the seven signals listed in Table 3-4. The input terms are sampled when the Chip Enable (CE) input at Z5C-15 goes true. Four signals must be present to allow CE* to go true: (1) RBR6 and RBR7 must both be zero; (2) the Data Received line (DR) from the UART must be true and (3) the Interface must be in Remote mode (REM switch term true).

The low, true outputs from pins 1-4 and 6-9 of Z5C are TTL levels and are converted to CMOS levels by the use of a buffer amplifier and a 10K pull-up resistor. The decoded outputs are as follows: Pin 1, Set Reader Decode (start reader) SRDEC*; Pin 2, Set Punch Decode (start punch), SPDEC*; Pin 3, Reset Reader Decode (stop reader), RRDEC*; Pin 4, Reset Punch Decode (stop punch), RPDEC*; Pin 6, Backspace (BS*); Pin 7, Set Reader Forward (drive right), SRFWD*; and Pin 8, Reset Reader Forward (drive left), RRFWD*. Each signal is further gated with one or more control signals and used with the punch and reader logic as described in Sections 4.3.9 and 4.3.10.

4.3.9 READER CONTROL LOGIC

Control of the reader logic depends upon whether the Interface is in local or remote mode operation. Data Selector chip Z4C (3E4) is used to select the reader control signal depending upon which mode of operation the Interface is in. In Local mode, the LOC signal is true (REMOTE switch out; 3C1) and the X₂ and X₃ signals are selected (X₀ and X₁ are used with the punch). In Remote mode, the REMOTE switch is depressed and the REM signal is true allowing the Y₂ and Y₃ inputs to be selected. Examining local mode first, the true Reader Enable (RDEN*) signal is generated when the READER switch is depressed and is applied to Z4C-15 (3D4). This signal then becomes the Set Reader Run (SRRUN*) at Z4C-13 and causes the 4-bit latch at Z4D-3 to be set. The Q₀ (Reader Run) output at Z4D-13 then goes true. When the READER switch is off, the RDEN* signal goes false and RDEN at Z4C-2 drops to 0V which activates the Reset Reader Run (RRRUN*) at Z4C-12 and Z3B-3. This signal resets the 4 bit latch and removes the Reader Run signal at Z4D-13. In local mode the reader direction is always to the right since the LOC forces the direction F/F, Z8F-6 (3A2) into the set state.

In remote mode, the control signals are decoded from the incoming data as described in Section 4.3.8 and applied to the Data Selector at Z4C, pins 1 and 3. The SRDEC* signal applied to Pin 1 generates the SRRUN* signal and the RRDEC* signal applied to Pin 3 generates the RRRUN* signal. Both the SRRUN* and RRRUN* are used by the 4-bit latch in the manner described above. The reader direction signals are also decoded as Set Reader Forward (SRFWD*) at Z5D-11 (3C6) which is drive right and Reset Reader Forward (RRFWD*) at Z5D-13 which is drive left. These signals are fed directly to the 4-bit latch to generate the true or false RFWD signal at Z4D-1. A true RFWD enables the Reader Direction F/F at Z8F-5 so that the next reader clock (RCLK) will set the F/F and enable gate Z8E-6. When reader step (RSTP*) comes true, the Drive Right (DRV RT*) line will go true and step the reader one line. If RFWD is false, Pin 1 of Z8F is low and the drive left (DRVLT*) line will be enabled.

The Reader Step (RSTP*) signal is used to actuate the DRVLT* or DRVRT* line. This signal is generated either from the internal NO PICK switch or the external PICK* signal at J1-25. If the PICK* input is used, the NO PICK switch (3A7) is open causing Pins 9 and 10 of Z6D (3B7) to be high. A second requirement for the gate is that the Transmitter Register Empty (TRE) signal from the UART be true (3B7). When these conditions are true and the PICK* signal goes true, Pin 13 of Z6D goes high and, in turn, generates the true Reader Step (RSTP*) signal at Z7C-4. If PICK* is not used, the NO PICK switch must be closed. This OV signal is inverted at Z2E-10 and is gated with TBRL to give the RSTP* signal.

RSTP* is also used to trigger the Data Ready one-shot at Z2G-11 (3B5). The \bar{Q} output is gated with the DRDY* signal at Z3G-3. Thus if the Reader Data Ready (DRDY*) doesn't come back in 25 - 35 ms, and the TRE signal is true, the Reader System Ready (RRTS*) goes true at Z3G-10 (3B4) which resets the 4-bit latch at Z4D-12 causing IRTS to go false. This will also occur if the Reader Run signal at Z3F-13 has been reset.

4.3.10 PUNCH CONTROL LOGIC

Like the reader, the control of the punch logic depends upon local or remote operation. Data Selector chip Z4C (3E4) is used to select the punch controls for either mode of operation. In local mode, the LOC signal selects the X₀ and X₁ inputs. The signal at these two inputs is the Punch Enable (PEN*) signal which is true when the PUNCH switch is depressed (3C1). In local mode, this signal becomes the Set Punch Start (SPCHS*) which sets the 4-bit latch at Z4D-7. PEN* is inverted at Z4C-4 and when PEN* is false, the Z1 output is low which resets the punch start line at Z4D-9. This signal is used to hold off the Punch F/F at Z4B-11 and Z1D-10 (3C4). In remote mode REM selects the decoded inputs at Z4C, Pins 5 (RPDEC*) and 7 (SPDEC*) as the RPCHS* and the SPCHS* signals.

The punch command (PCMD) signal is generated at Pin 13 of the Z1D F/F (3C5). This F/F is enabled when the Data Received (DR) output from the UART is true. When the next punch clock (PCLK*) is received, the F/F is set causing the Punch Command (PCMD) to be true. An eight term OR gate (Z4B) is used to reset the F/F. It is reset by any of the coded signals described in Section 4.3.8 (except back space), or by the punch stop term from the 4-bit latch, or by the punch ready (PRDY) command from the punch when it goes false at the beginning of a punch cycle.

Punch direction is controlled by the Z8F F/F (2C4). For forward direction the F/F is reset by the Data Received line (DR) causing Pin 13 to go low. The PCH DIR at J3-11 will then go high causing the punch to operate in the forward direction. When the Interface is in remote (REM true) and a Back Space (BS) command has been decoded, the F/F is forced into the set state which gives a low (reverse) output at J3-11. No provision is made for back space in local control.

4.3.11 END OF TEXT/CARRIAGE RETURN LOGIC

Reader outputs DB1-DB8 and/or their inversions (DB1*-DB8*) are used directly to decode the end of text character. Jumpers P5-P9 and P12 (2C5) are manually arranged to select any desired code. The selected terms are applied to the 8 level AND gate Z6A (2B4). When all eight terms are positive and TBRL from Z2C-10 (2A3) goes high, the End of Text (EXT*) signal at Pin 13 of Z6A goes low.

The ETX* signal is used two places: (1) it is used at Z4E-12 (3E6) to reset the reader run at Z4C-3 and at Z4D-4. This will cause the reader to stop unless the Carriage Return is active (NO CR switch is open) as described later in this paragraph. If CR is selected, when the delay has timed out, CRDLY* is applied to Z3B-9 (3D5) which then sets the reader run line. (2) ETX* is also inverted at Z2E-2 (2B4) and used to trigger the carriage return one-shot, Z14, provided the NO CR switch is open. The output at Z14-6 is the resulting Carriage Return Delay (CRDLY*) signal at Z1B-4. Z14 is enabled by the NO CR switch in the open position which allows a high level to be placed at Z14-5. If carriage return is not required the NO CR switch is closed and the 0V signal disables the one-shot. To provide a speed-up so that CRDLY* appears sooner than would normally occur due to the turn-on time of Z14, F/F Z1D (2B2) is set as soon as the ETX* goes low (Pin 2 of Z2E goes high). It is reset at Z1D-4 when the one-shot output goes high. The CRDLY* signal is then gated with the WDRDY signal (see Section 4.3.3.2) and used to enable the TBRL logic.

4.3.12 TBRL LOGIC

The transmitter buffer register load (TBRL) signal is used to signal the UART that parallel data is ready to be loaded. The circuit is enabled at Z2D-9 (2A5) by a signal from the carriage delay logic (see Section 4.3.11) which indicates that the Carriage Delay (CRDLY*) signal, if present, has timed out and the Word Ready (WDRDY) signal is present. When the next reader clock (RCLK*) is present, the Q output at Z2D-13 goes high. Since Z2D-13 has been low, Z2D-2 is high and TBRL* goes low. The second RCLK* signal will then set the second F/F at Z2D-3 provided the conditions at Z4E-1 are true: (1) Reader System Ready (RSR) is true, (2) Internal Clear to Send (ICTS) is true, (3) Internal Request to Send (IRTS) is true, and (4) Data Set Ready (DSR) is true. The Q output at Z2D-2 then goes negative causing TBRL* to go positive which is used as the trigger edge for the UART.

4.3.13 DATA TERMINAL READY LOGIC

Several signals are gated together to illuminate the Data Terminal Ready Indicator (5D3). Beginning with J3-10, the Punch Ready (PCH RDY) signal which is TTL logic is buffered at Z8C-8 and shifted to CMOS levels. The signal is then gated at Z1F-13 with the Data Received (DR) signal and the resulting output at Z1F-11 is used to trigger one-shot Z2G at Pin 5. This one-shot is used to generate a Punch Time Out (PCHTO*) signal at Z2G-7 which when low indicates a punching cycle. The Q output at Z2G-6 is used to set F/F Z3E at Pin 8 which artificially provides the punch ready signal at Z3E-13 for approximately 30 ms during punching time (PCH RDY at J3-10 goes away during the punch cycle).

The output at Z3E-13 is gated with the combination of the Punch System Ready (PSR*) and the Tape Chad Error (T/CER) at Z7F; pins 12 and 13 (5D5). Output Z7F-11, in turn, is inverted and gated with the Parity Error (PE) signal, provided the Parity Data Terminal Ready (PAR DTR) is selected and with the Reader System Ready (RSR) signal at Z3G, Pins 1, 2 and 8 to give the Internal Data Terminal Ready Signal (IDTR) at Z3G-9. This signal turns on Q1 which illuminates the Data Terminal Ready Indicator.

Table 4-2. Signal Mnemonics

Signal	Source	Description
BS*	3D6	Back Space. A decoded ASCII character which directs the punch to back-up one space.
CRDLY*	2B1	Carriage Return Delay. A delay which inhibits the reader for a predetermined amount of time when a pre-selected ASCII character is read from the tape.
DB1, DB1* thru DB8, DB8*	2E6	Data Bits 1-8. Parallel input data from the reader which feed the parallel to serial converter and the jumper plug which selects the ETX (CR) signal.
DR	2D5	Data Received. Output from the UART which indicates the parallel data has been received.
DRDY DRDY*	2B7	Data Ready Input. Input signal from reader indicating data is present and can be read.
DRR*	3D4	Data Ready Reset. Input to UART which resets the UART and allows new data to be processed.
DSR*	4C6	Data Set Ready. Indicates either a Modem DSR true signal or a Terminal DTR signal has been received.
ECHO ECHO*	4C1	Echo. Signal generated by ECHO switch which allows input signal to be echoed back to sender (either terminal or modem).
ETX	2B4	End of Text. ASCII Code used for the reader delay signal to allow for a carriage return or for stopping the reader.
ICTS	3C6	Internal Clear to Send. Indicates clear to send signal has been received from modem or from the Internal CTS EXT switch.
IDTR	5C4	Internal Data Terminal Ready. Indicates both reader and punch are ready to communicate and no parity error exists. This signal is used to illuminate Ready indicator.
IRTS	3C2	Internal Request to Send. Indicates reader is ready and data is ready to send.
IXMTD	4C6	Internal Transmit Data. Serial output of UART (TRD) which has been gated with false TTY* signal.
LOC	3C1	Local. Generated from the REMOTE switch on the front panel (true when switch is out).
MCTS	4D6	Modem Clear to Send. Signal from modem indicating it has responded to request to send and is ready to accept data.
MOD	4C1	Modem. Signal generated by the MODEM switch which indicates switch has been depressed.
MR MR*	2C3 2B3	Master Reset. Signal indicates power has reached operating levels. It is used to reset many of the IC's used in the interface.
M/T	4B1	Modem/Terminal. Signal true when both the MODEM and TERMINAL switches have not been depressed i.e., the MONITOR switch has been depressed which releases both switches.
PCHTO*	5C5	Punch Time Out. Used in local mode to allow punching cycle to be completed if PUNCH switch is released.
PCLK PCLK*	5D3	Punch Clock. Output from the clock divider to time punch circuitry.
PCMD	3C4	Punch Command. Signal generated when the DR signal from the UART is true and a punch clock is present and is used as punch command input to the punch.
PE	2D5	Parity Error. Output from UART indicating a parity error is present.
PEN*	3C1	Punch Enable. Generated from the Punch switch on the front panel and is used to indicate the punch has been selected.
PRDY	5D7	Punch Ready. Input from the punch indicating it is ready to receive data.
RBR1- RBR7	2E3	Receiver Buffer Register Bits 1 - 7. Parallel data outputs from UART.
RCLK RCLK*	5E3	Reader Clock. Output from the clock circuit which is used to clock various reader function flip-flops.
RDEN RDEN*	3D1 3C1	Reader Enable. Generated from the READER switch on the front panel and is used to indicate reader has been selected.
REM	3C1	Remote. Generated when REMOTE switch on front panel is depressed and is used to indicate remote mode operation.
RPDEC*	3D6	Reset Punch Decode. In Remote mode, this decoded ASCII character stops the punch by resetting the Punch Command F/F.
RRDEC*	3E6	Reset Reader Decode. Decoded ASCII character used to stop the reader when operating in remote mode.
RRFWD*	3C6	Reset Reader Forward. In Remote mode, this decoded ASCII character enables the reader to drive tape left.
RRI	4A3	Receive Register Input. Serial data input to the UART from modem, terminal or TTY.
RSR	2A5	Reader System Ready. True signal from reader indicates the reader is ready for operation. Generated by RDR IN switch when reader is not connected.
SDI	4A4	Serial Data In. Input serial data from TXMTD or from MRCVD line.
SPDEC*	3E6	Set Punch Decode. In Remote mode, this decoded ASCII character enables the Punch Command F/F by removing the reset signal.
SRDEC*	3E6	Set Reader Decode. In Remote mode, this decoded ASCII character enables the reader to run.
SRFWD*	3C6	Set Reader Forward. In Remote mode, this decoded ASCII character enables the reader to drive tape right.

Table 4-2. Signal Mnemonics (Continued)

Signal	Source	Description
SWRTS	3C7	Switch Request to Send. Signal generated by opening the CTS EXT switch when external terminal does not have its own clear to send signal.
TBRE	2D5	Transmitter Buffer Register Empty. Output signal from UART indicating serial data is complete and UART is ready for next transmission.
TBRL	2A3	Transmitter Buffer Register Load. Signal used to load parallel data into the UART.
T/CER	5DE	Tape/Chad Error. Input from punch indicating a tape handling or a chad error.
TCTS	4C4	Terminal Clear to Send. Output signal to terminal indicating that the interface is ready to accept data from the Terminal device.
TERM	4B1	Terminal. Signal generated by the TERMINAL switch and is used to indicate terminal mode selection to the various logic circuits.
TDO	4B4	Transmit Data Out. Serial data from TRO, MRCVD or TTY to be transmitted out to the terminal.
TDSR	4C4	Terminal Data Set Ready. Output signal to terminal indicating MDSR is true in monitor mode or IDTR is true in terminal mode. This tells the Terminal device that the interface is ready but not necessarily ready for data interchange.
TRE	2D5	Transmitter Register Empty. Output from UART indicating that the register is empty.
TRO	2D5	Transmit Register Out. Serial Output data from UART of the DB1 - DB8 inputs including start bit and stop bit codes.
TTY TTY*	4D1 4C1	Teletype. Signal generated by TELETYPE switch when depressed and used as a logical signal to indicate selection of teletype (current loop) input and output.
WDRDY	3B6	Word Ready. True signal indicates reader is ready (Data Ready true and Reader Run true) to send data.
XMTD	4B4	Transmit Data. Selected serial data to be transmitted depending upon selection of the front panel switches.

4.3.14 POWER SUPPLY CIRCUITS

Power to the Interface is applied through FL1 (5B8) which is a RFI filter to reduce noise input. Switch S102 allows either 115 or 230 volts to be applied to the primary of T1 by placing the primary winding in parallel or series respectively. The output is rectified at CR1-CR4 and applied to regulator Z1 and Z2. These regulators are used to develop the +8 and -8 Vdc power supplies respectively. A 1% resistor divider network at the output of each regulator is used to program the device by picking off a proportional voltage and feeding it back to the device. Each regulator contains an internal current limiting circuit in the event of a current overload. A third regulator is placed in the +8V line and is used to generate the +5 Vdc supply.

SECTION V

MAINTENANCE

5.1 GENERAL

The REMEX RS-232 Interface has been designed to keep maintenance as simple and infrequent as possible. Table 5-1 lists the maintenance equipment required for the various procedures. Since this unit is primarily electronic with only one mechanical assembly, that of a switch assembly, no preventative maintenance schedule is recommended. No periodic calibrations are required. Section 5.2 outlines possible malfunctions along with probable causes and remedies. The remaining sections give specific data useful in maintenance. Replacement procedures are given in Section 6.

Table 5-1. Maintenance Equipment Required

<u>Item</u>	<u>Quantity</u>
*Frequency Counter, 10 Hz to 100 kHz	1
*Oscilloscope, dc to 10MHz, Single Sweep	1
*Voltmeter, Digital 0.01 mA, 0-100 mVdc, 0-100 Vdc, 100K impedance or greater	1

*These items are not available from REMEX.

5.2 TROUBLE-SHOOTING

Trouble-shooting is presented in the form of a chart, Table 5-2, which should be consulted whenever the interface performance is unsatisfactory. Separate manuals exist for the reader and the punch and these should be consulted in the event a malfunction is suspected in these units. The chart is divided into three columns: Indication - the way in which the malfunction became evident; Probable cause - the possible reason or reasons for the malfunction and Remedy - the manner in which the malfunction may be corrected. It is assumed that all connectors and jumpers are properly mated and that the necessary DC power supply levels are present.

The RJX232 interface contains only one circuit board which contains a majority of CMOS IC components. These should be identified and noted during maintenance procedures.

CAUTION

Some of the components used in this REMEX product contain MOS (metal oxide semi-conductor) devices. By nature, these devices are highly susceptible to damage through improper handling. Internal damage will occur due to static electrical discharge if the device is handled without the proper precautions.

The following minimum procedures in handling these devices are strongly recommended by REMEX:

1. Devices received in original packages or special conductive carriers containing warning labels should remain in these packages at all times until the time of installation.
2. No particular precautions are required with a unit unless a P.C. assembly is removed from that unit or a MOS device is being handled.
3. Persons making any repair shall wear a conductive wrist strap on the wrist next to the skin. Connect the ground wire from the wrist strap to conduit ground through a 1 megaohm resistor or to a conductive bench top (item 4).
4. Repair shall be conducted at a properly equipped static-free workstation which consists of a properly grounded conductive bench top with provisions for connecting the operator's wrist strap. Grounding of the bench top to conduit ground shall be accomplished through a 1 megaohm resistor.
5. Soldering irons shall be of the type containing a grounded tip.
6. Return all unused MOS devices to the special conductive anti-static bags.
7. The following list of equipment is recommended:
 - a. Bench Top, conductive sheet. 3M, Velostat #1802.
 - b. Wrist Strap, conductive with ground strap. 3M, Velostat #2060.
 - c. Ground Strap, conductive. 3M, Velostat #3030 with grommets and clips.
 - d. Conductive Foam. 3M, Velostat #1902.
 - e. Soldering Iron. Weller #W-TCP with grounded tip.
 - f. Conductive Anti-Static Bag. 3M, Velostat #2004 in appropriate sizes as required.

Table 5-2. Troubleshooting

Indication	Probable Cause	Remedy
No power	Fuse F1 blown	Replace fuse at rear of unit.
	Filter FL1 defective	Check FL1 for proper operation.
	Switch S101 defective	Check POWER switch for proper operation.
	T1 defective	Check for proper operation of T1.
READY INDICATOR does not light	One or more inputs from punch not present	Check for the following signals: Punch System Ready*, Tape Chad Error and Punch Ready.
	Punch Ready one-shot does not trigger	Make sure the 30 ms one-shot Z2G is true during the time the Punch Ready signal is false.
	Parity Error Present	Check for presence of parity error.
	Reader Not Ready	Check for presence of Reader System Ready (RSR) at Z3G-2.
	PCH IN switch in wrong position	Make certain PCH IN is in the proper position as described in Table 3-3.
Ready Clock or Punch Clock not present	I C Chip Z3C malfunction	Check Z3C and replace if required.
	Crystal Y1 inoperative	Check Y1 and replace if required.
Serial data not being transmitted	Reader input not present	Make sure the reader is functioning properly and parallel input data is being received.
	UART Malfunction	Check for proper operation of Z6B to see that TRO is transmitting serial data.
	Data Selector Malfunction	Check data selector to see that either the XMTD or TD0 line contains serial data and it is being applied to the proper port depending upon switch selection.

Table 5-2. Troubleshooting (Continued)

Indication	Probable Cause	Remedy
Data Not Being Punched	Data Not being received from source	Check data source (modem, terminal or TTY) to see that data is being received. Check Z5E-3 to see if data is being applied to UART via the RRI line.
	UART Malfunction	Check for proper operation of Z6B to see that parallel outputs result from RRI input.
	Punch Malfunction	Make sure the punch is functioning properly and is receiving the parallel input.
Reader or Punch doesn't respond to ASCII Characters	PROM Defective	Check Z5C for proper operation. Replace if defective.
	Data Selector Z4C Malfunction	Check Data Selector Z4C for proper selection during remote or local mode.
	4-Bit Latch Z4D Malfunction	Check Z4D for proper set and reset operation.
	Punch Command F/F not being reset	Check Z1D F/F to make sure it is reset by the 8 term OR gate Z4B.
Reader drives in wrong direction	4-Bit Latch Z4D Malfunction	Check Z4D for proper set and reset operation.
	Reader direction F/F Malfunction	Check F/F Z8F for proper operation.
No Carriage Return Delay	No CR switch in wrong position	Check that the NO CR switch is open for enabling CR.
	CR one-shot Malfunction	Check operation of Z14 for proper operation and R23 for proper setting of one-shot pulse width.
	CR F/F Malfunction	Check to see Z1D sets ahead of Z14 and is reset when Z14 is fired.
	Wrong code selected	Check P5-P9 for proper selection of End of Text code.

Table 5-2. Troubleshooting (Continued)

Indication	Probable Cause	Remedy
Punch Direction Wrong	Punch Direction F/F not in proper state	For forward direction check to see Z8F is reset by the Data Received (DR) signal. For reverse (backspace) operation check to see F/F is set by BS* and REM signal from Z2F-4.
PICK* does not step Reader	NO PICK switch in wrong position	If the reader is to be operated by the PICK input, the NO PICK switch must be open.
	TBRE signal from UART not present	Check UART output signal TBRE for proper operation.

The theory section of this manual (Section IV) is written to support the corrective maintenance process. It is strongly recommended that the reader review the theory of operation to become familiar with the circuit operation before attempting troubleshooting procedures.

WARNING

Potentially dangerous line voltage is applied to components within this equipment. Before performing any maintenance or troubleshooting procedures on or removing components from the Interface, remove AC power by disconnecting the AC power plug. When it is necessary to make tests with power applied, avoid touching AC power circuits in the areas in the primary circuits which include: FL1, F1, S101, S102 and T1. Most of these areas are sleeved to protect the serviceman. Always remove power before disconnecting any plugs or connectors.

5.3 MAINTENANCE AIDS

5.3.1 POWER SUPPLY VOLTAGES

Table 5-3 lists the various power supply voltages. These should be checked periodically since a change in voltage may be indicative of a gradual component failure. Before taking any measurements, allow a short period of time for warm-up after turning on power. These are no adjustments for the Power Supply Voltages.

Table 5-3. Power Supply Voltages

<u>Nominal Voltage and Tolerance</u>	<u>Test Location</u>		<u>Maximum Current</u>
	<u>From</u>	<u>To</u>	
+8 Vdc ± 0.5V	TP4	TP2	230 mA
+5 Vdc ± 0.25V	TP1	TP2	70 mA
-8 Vdc ± 0.5V	TP3	TP2	60 mA

5.3.2 TEST POINTS

Table 5-4 gives the ten test points on the circuit card. Refer to Figure 7-3 for their locations.

5.3.3 CLOCK

The send (reader) clock is accessible at TP6 and the receive (punch) clock is accessible at TP8. The clock rates are 16 times the data rates. If for example the data rate is 1200 Baud, the clock is $16 \times 1200 = 19.2$ kHz. The voltage levels are zero to 0.4V and $+8 \pm 0.5V$.

5.3.4 CARRIAGE RETURN DELAY ONE-SHOT ADJUSTMENT

The following procedure is recommended when adjusting the Carriage Return Delay one-shot, Z14. See Figure 7-3 for location of Z14, R23 and R25.

- a. Place the POWER switch in the off position.
- b. Set the NO CR switch to the off position (lever away from lettering)
- c. Set-up ETX code on J5, J6 and J7 as described in Table 3-3.
- d. Insert a tape loop into the reader which contains all ETX codes. This will allow the one-shot to keep triggering until the adjustment can be made.
- e. Place POWER switch in the on position.
- f. Select LOCAL mode and the READER.
- g. Place an oscilloscope probe between R25 and Z14-6 (See Figure 7-3). Adjust R23 for a positive going pulse of 600 ms. If required for a special application this pulse width can be reduced down to 10 ms or expanded to 1 second. It is factory set at 600 ms.

Table 5-4. Test Points on the Circuit Card

<u>Test Point</u>	<u>Signal</u>
TP1	+5 Vdc
TP2	Signal Ground
TP3	-8 Vdc
TP4	+8 Vdc
TP5	DR Output from UART
TP6	RCLK*
TP7	RRI Input to UART
TP8	PCLK
TP9	TBRL*
TP10	TRO Output from UART

SECTION VI

PARTS REPLACEMENT

6.1 GENERAL

REMEX maintains service facilities at its manufacturing location and at service centers in major population areas for repair or replacement of components for their products. It is recommended that one of these centers be contacted for assistance in case of equipment malfunction. For the locations of service facilities in any area, contact REMEX at the address listed on the title page of the manual. Please direct inquiries to the attention of the Service Department.

When any parts of the interface require replacement or disassembly, the procedures below should be followed closely. The warnings and cautions are included to protect personnel and equipment. Notes are included to assist persons unfamiliar with the equipment. Before attempting any procedure, all instructions for that disassembly should be read and understood.

All components are identified in Section VII of this manual along with illustrations showing part locations. Components are identified on the board by the designation printed along side the component.

WARNING

Potentially dangerous line voltage is applied to components within this equipment. Before performing and maintenance or troubleshooting procedures on or removing components from the Interface, remove A C power by disconnecting the A C power plug. When it is necessary to make tests with power applied, avoid touching AC power circuits which include FL1, F1, S101, S102 and T1. Most of these areas are sleeved to protect the serviceman. Always remove power before disconnecting any plugs or connectors.

6.2 PARTS REPLACEMENT

6.2.1 COVER REMOVAL

The following procedure should be followed when removing the cover:

- a. Remove all power and control signals by disconnecting the power plug, P1, P2 and P3.
- b. Remove the six 4-40 x 5/16 screws (three on each side) which hold the cover to the chassis.
- c. To remove the cover, slide it forward, off the chassis.
- d. Installation of the cover is the reverse of steps c, b and then a.

6.2.2 PRINTED CIRCUIT CARD REMOVAL

The following procedure is recommended when removing the circuit card:

- a. Remove the top cover by performing Section 6.2.1.
- b. Unplug P4.
- c. Remove the six 4-40 x 3/8 binder head screws which hold the circuit card to the chassis. Slide the card back slightly so that the switches clear the front panel and remove the card.
- d. Installation is the reverse of steps c, b and then a.

SECTION VII

PARTS LIST

7.1 GENERAL

Tables 7-2 and 7-3 list the electronic and mechanical parts used in the three interface models. Table 7-1 lists the recommended spare parts for these models. Standard hardware items are not listed. Indented items are part of the assembly under which they are indented and the quantity of the indented item is per each assembly. An X in a particular model number digit designator denotes any of the combinations given in Figure 1-5 for that designator is applicable. Note that the Quantity column is divided into three sections denoting each of the -001 through -003 assemblies for the 113771* top assembly.

Reference designations refer to parts illustrated in Figures 7-1 through 7-4. The reference designations include a figure number and a part designation number which appears on that figure to indicate the location of the part. For example a "7-1, 2" appearing in the reference designation column indicates that the item listed in the description column is identified as Item 2 in Figure 7-1. Note that most of the references to Figure 7-1 also apply to 7-2 and references to 7-3 also apply to 7-4 since the two models are similar. All electronic components are identified by letter-number combinations (such as S1 and T1) in the Reference designations column and mechanical parts are identified by a number only. Reference designations contained in parenthesis are associated or function with the parenthetical item. These items are generally individual items and not part of an assembly but for reference are related back to the main item. All items are available from the Spares Order Desk, REMEX, 1722 Alton Street, P.O. Box C-19533, Irvine, California 92713.

7.2 KIT OF PARTS

The kit of parts contains items used for installation and maintenance and is shipped with the unit. These items are listed in Table 1-1.

NOTE: WHEN ORDERING SPARE PARTS, CONTACT REMEX SPARES ORDER DESK AND REFERENCE COMPLETE MODEL AND SERIAL NUMBER OF UNIT. ALWAYS REFER TO ADDENDUM AT THE REAR OF THE MANUAL (IF APPLICABLE) FOR POSSIBLE PART NUMBER CHANGES.

Table 7-1. Recommended Spare Parts

Description and Manufacturer's Part No.	REMEX Part No.	Quantity	Reference Designation
Printed Circuit Card Assembly, RJA2322 Only	113771-001	1	PC1
Printed Circuit Card Assembly, RJA2321 Only	113771-002	1	PC1
Printed Circuit Card Assembly, RJR2321 Only	113771-003	1	PC1

NOTE: WHEN ORDERING SPARE PARTS, CONTACT REMEX SPARES ORDER DESK AND REFERENCE COMPLETE MODEL AND SERIAL NUMBER OF UNIT. ALWAYS REFER TO ADDENDUM AT THE REAR OF THE MANUAL (IF APPLICABLE) FOR POSSIBLE PART NUMBER CHANGES.

Table 7-2. Parts List, RJA2322, RJA2321, RJR2321

Description and Manufacturer's Part No.	REMEX Part No.	Quantity	Reference Designation
In the Quantity column -1 represents -001, -2 represents -002 and -3 represents -003.		-1 -2 -3	
Top Assembly, RJA2322-B	113780-001	1 - -	Ref.
Top Assembly, RJA2321-B	113780-002	- 1 -	Ref.
Top Assembly, RJR2321-B	113780-003	- - 1	Ref.
Chassis Assembly	113388-001	1 1 1	Ref.
Chassis	113375-001	1 1 1	7-3, 1
Connector, Housing, 3-pin, White Molex 09-50-7031	706510-258	1 1 1	7-3, P4
Contact, Connector, Molex 08-50-0106	706530-137	3 3 3	(P4)
Fuseholder, Littlefuse 348870	705750-117	1 1 1	7-3, F1
Shield, Switch, Switchcraft G5874	715057-112	1 1 1	(S102)
Stand, Retractable, Buck Eye Stamping MP-40008-3	714096-117	1 1 1	7-1, 3
Suppression Assembly, Corcom 6EF1-E1/APF600CEE	702250-111	1 1 1	7-3, FL1
Switch, C&K U11-J2-Z3-Q-1	715055-150	1 1 1	7-3, S101
Switch, Slide, DPDT, Switchcraft 46256LFR	715057-111	1 1 1	7-3, S102
Terminal, H. H. Smith 1415-6	715000-105	1 1 1	7-3, E1
Transformer REMEX Specification	703010-163	1 1 1	7-1, 1
Cover	113376-001	1 1 1	7-1, 1
Kit of Parts, See Table 1-1 for Contents	113386-001	1 1 1	Ref.
Name Plate, REMEX Specification	716018-113	1 1 1	
Panel, Front	113377-001	1 - -	7-1, 2
Panel, Front, 5 Function	113384-001	- 1 -	7-2, 2
Panel, Front, 1 Function	113385-001	- - 1	
Printed Circuit Card Assembly	113771-001	1 - -	7-3, PC1
Interface, 8 switches. See Table 7-3 for contents			
Printed Circuit Card Assembly Interface, 5 switches, See Table 7-3 for contents	113771-002	- 1 -	7-4, PC1
Printed Circuit Card Assembly Interface, 1 switch. See Table 7-3 for contents	113771-003	- - 1	
The following assembly is contained in the Kit of Parts.			
Cable Assembly, Interconnect	113619-001	1 1 1	Ref.
Connector, 25-pin, Cannon DB-25S	706510-211	1 1 1	P1
Connector, 25-pin, Cannon DB-25P	706500-231	1 1 1	P2
Connector, 3M 3414-0000	706510-213	1 1 1	P3
Junction Shell, Cannon DB24659	706540-144	2 2 2	P1, P2
Key, Polarizing, 3M 3435-0000	706540-153	1 1 1	(P3)
Screw Lock Assembly, Male, Cannon D-20419-16	706540-124	2 2 2	P1, P2
The following is an option.			
Kit Rack Mounting, RMJ 0001	113391-1	1 1 1	
Panel, Rack	113378-1	1 1 1	
Screw, BHMS, 6-32 x 7/16	709031-307	4 4 4	

NOTE: WHEN ORDERING SPARE PARTS, CONTACT REMEX SPARES ORDER DESK AND REFERENCE COMPLETE MODEL AND SERIAL NUMBER OF UNIT. ALWAYS REFER TO ADDENDUM AT THE REAR OF THE MANUAL (IF APPLICABLE) FOR POSSIBLE PART NUMBER CHANGES.

Table 7-3. Parts List Interface Card 113771-001, 002, 003

Description and Manufacturer's Part No.	REMEX Part No.	Quantity	Reference Designation
Model RJA2322 uses -001 assembly (Figure 7-3), Model RJA2321 uses -002 assembly (Figure 7-4) and Model RJR2321 uses -003 assembly. This parts list was written for the D assembly and F schematic revisions. Subsequent revisions are listed on a P.C. Card Change Record form contained in the addendum.		-1 -2 -3	
In the Quantity column -1 represents -001, -2 represents -002 and -3 represents -003.			
Capacitor, 250 μ f, 25V, Electrolytic Cornell Dubilier, P C Class 201.1	702365-257	1 1 1	C1
Capacitor, 0.22 μ f, 50V, Ceramic, monolythic Sprague 7C023224D8500E	702131-224	3 3 3	C2-C4
Capacitor, 10 μ f, 25V, Solid Tantalum Sprague 196D106X9025KA1	702395-106	1 1 1	C5
Capacitor, 50 μ f, 25V, Electrolytic Cornell Dubilier, P C Class 201.1	702365-506	1 1 1	C6
Capacitor, 0.01 μ f, 100V, Ceramic Disk, Eric 805X5V103Z	702121-103	13 13 13	C7-C9, C27- C32, C35, C41, C43, C47
Capacitor, 470 pf, 200V, Ceramic, Type CK05	702128-471	10 10 4	C18-C25, C44, C46 C26
Capacitor, 1 μ f, 35V, Solid Tantalum, Polarized Sprague 196D105X9035HA1	702396-105	1 1 1	
Capacitor, 330 pf, 200V, Ceramic, Type CK05	702128-331	6 3 3	C33, C34, C36-C39 C40, C42
Capacitor, 0.22 μ f, 100V Metallized Mylar Electrocube 217A1B224K	702181-224	2 2 1	
Capacitor, 3.3 μ f, 15V, Solid Tantalum Polarized, Sprague 196D335X9015HA1	702394-335	1 1 -	C45
Capacitor, 0.02 μ f, 100V, Metallized Mylar Electrocube, 217A1B203K	702181-203	1 1 1	C48
Connector, 25-pin, Cannon DBP-25 PAC	706500-255	1 1 1	J1
Connector, 25-pin, Cannon DBP-25 SAC	706510-267	1 - -	J2
Connector, 34-pin, Berg 65461-014	706500-289	1 1 1	J3
Connector, 3-pin, White, Molex 09-60-1031	706501-039	1 1 1	J4
Connector, 6-pin, Molex 22-03-2061	706500-317	3 3 -	J5, J6, J7
Connector, 8-pin, Molex 22-03-2081	706500-308	2 2 2	J8, J9
Connector, 5-pin, Molex 22-03-2051	706500-315	2 2 -	J10, J11
Connector, 2 socket, Amp 530153-2	706510-314	9 9 2	P5-P11
Crystal, 1,8432 MHz, Cal Crystal HC6/1,8432	703800-112	1 1 1	Y1
Diode, 1N5059	704000-107	4 4 4	CR1-CR4
Diode, LED, REMEX Specification	704004-006	1 1 1	CR5
Diode, FDH6666	704000-110	1 1 -	CR6
Heat Sink, IERC PB1-2CB	715033-135	1 1 1	(Z1)

NOTE: WHEN ORDERING SPARE PARTS, CONTACT REMEX SPARES ORDER DESK AND REFERENCE COMPLETE MODEL AND SERIAL NUMBER OF UNIT. ALWAYS REFER TO ADDENDUM AT THE REAR OF THE MANUAL (IF APPLICABLE) FOR POSSIBLE PART NUMBER CHANGES.

Table 7-3. Parts List Interface Card 113771-001,002, 003 (Continued)

Description and Manufacturer's Part No.	REMEX Part No.	Quantity	Reference Designation
I.C. Package, 74C906	704800-105	6 6 3	Z8A, Z8B, Z8C, Z7E, Z5D, Z1C
I.C. Package, 4069	704800-110	6 6 6	Z7A, Z7B, Z2C, Z2E, Z6E, Z1B
I.C. Package, 4081	704800-112	5 5 4	Z4E, Z2F, Z3B, Z6G, Z5G
I.C. Package, 4001	704800-107	1 1 1	Z7C
I.C. Package, 4082	704800-114	1 1 1	Z6D
I.C. Package, 4071	704800-111	4 4 3	Z3F, Z8E, Z4G, Z1G
I.C. Package, 4011	704800-108	2 2 2	Z7F, Z1F
I.C. Package, 4073	704800-113	2 2 2	Z3G, Z1E
I.C. Package, 4050	704800-115	1 1 -	Z5B
I.C. Package, 4049	704800-103	3 3 2	Z7D, Z8D, Z9C
I.C. Package, 4068	704800-109	2 2 -	Z6A, Z4B
I.C. Package, IM6402A	704810-115	1 1 1	Z6B
I.C. Package, 4013	704810-106	5 5 3	Z2B, Z6F, Z8F, Z3E, Z1D
I.C. Package, MC14411	704810-114	1 1 1	Z3C
I.C. Package, 4528	704810-113	2 2 1	Z2G, Z14
I.C. Package, 4019	704810-109	3 2 1	Z4CZ8G, Z7G
I.C. Package, 4085	704810-111	2 2 -	Z5F, Z5E
I.C. Package, 4044	704810-112	1 1 1	Z4D
I.C. Package PROM IM 5610	113379-001	1 1 -	Z5C
I.C. Package, 75189	704610-175	2 1 1	Z9D, Z9G
I.C. Package, 75188	704610-174	2 1 1	Z9E, Z9F
I.C. Package, 4N28	704216-101	2 2 -	Z9, Z15
I.C. Package, Resistor, 2.2K	701900-014	2 2 2	Z9A, Z9B
I.C. Package, Resistor, 10K	701900-007	5 5 4	Z5, Z6, Z10-Z12
I.C. Package, Resistor, 100K	701900-015	4 4 4	Z4, Z7, Z8, Z13
Resistor, 8.25K, 1/4W, ± 1%	701218-251	1 1 1	R1
Resistor, 5.11K, 1/4W, ± 1%	701215-111	1 1 1	R2
Resistor, 2.15K, 1/4W, ± 1%	701212-151	1 1 1	R3
Resistor, 5.62K, 1/4W, ± 1%	701215-621	1 1 1	R4
Resistor, 4.7K, 1/4W, ± 5%	701003-472	4 4 2	R5, R8, R13, R14
Resistor, 15M, 1/4W, ± 5%	701003-156	1 1 1	R6
Resistor, 270 ohm, 1/4W, ± 5%	701003-271	2 2 -	R7, R9
Resistor, 100K, 1/4W, ± 5%	701003-104	1 1 1	R11
Resistor, 10K, 1/4W, ± 5%	701003-103	6 6 3	R10, R16, R18
Resistor, 22K, 1/4W, ± 5%	701003-223	1 1 1	R22, R24, R25 R29

P.C. CARD CHANGE RECORD

CARD ASSY NO. 113771-001 thru-00
 SCHEMATIC NO. 113772-001

SCH REV	ASSY REV	FAB REV	DESCRIPTION OF CHANGE
B	C	A	Added PICK signal at S10-3 (3A7). Deleted 8E-11, 12, 13 (4C6). Changed RSR circuit (2A5), 2A6, 2B1). Allows CTS to be used to Start/Stop reader.
C	C ₁	A	Added TBRL signal at Z2C-10 (2A3). Z8E-13 is TRE was TBRE. Z6D-11 was tied to TRE is now tied to TBRE; Z2E-10 was tied to Z4E-5 is now tied to Z5G-8. Connection between Z6F-1 and Z5G-8 deleted. Z5G-9 tied to TBRL instead of Z6F-12.
D	C ₂	A	Revised circuitry on sheet 4, zones C5, C6, C7, D5, D6, D7, E5, E6 and E7 to eliminate glitch on RS232 bus when change of modes for Terminal to monitor is made. No component change.
E	C ₃	A	Make the following circuit changes: Pg 8-7/8-8 zone B7, remove RRUN signal from Z6D-10. Tie Z6D-10 to Z6D-9; zone C8 Z5G-5 signal should be MM/T instead of MOD. Pg 8-9/8-10, zone A6, tie MMT to Z5F-9; zone C7, Z5E-5 signal should be MM/T instead of MOD. On page 8-9/8-10, zones E7, E6, break connection between Z6E-2 and Z8G-7. Tie Z6E-2 to unused OR gate Z4G-2. Z4G-3 output ties to Z8G-7. The other input to Z4G at 1 ties to Z8G-6.
F	D	D	On sheet 2, zone C7 added signal DB8*. On sheet 2, zone B5 added DB8* to Z6A-3. DB6* and DB7* are now ANDED at Z4E-1, 2 and applied to Z6A-2. On sheet 2, zones D1, D2, C1 and C2 added Z14 one shot which ties to Z1G-6. Z14-6 no longer ties to Z1G-6. On sheet 3, zones A6, A7, B6, B7 deleted AND gates Z6G pins 12 and 13. Pin Z6E-2 no longer connects to Z8G-7 instead of Z8G. Z4G-1 now connect to Z8G-6. Changed connect type for J5, J6 and J7. Added connector P12 and P13. Added Z1E on -003 assembly. Added R29 and R30. Added C48 and test points A1, A2 and A3. R30 allows for a reader intercharacter delay as described in Section 3.7.2.

112670-092B

7-6A/7-6B

NOTE: WHEN ORDERING SPARE PARTS, CONTACT REMEX SPARES ORDER DESK AND REFERENCE COMPLETE MODEL AND SERIAL NUMBER OF UNIT. ALWAYS REFER TO ADDENDUM AT THE REAR OF THE MANUAL (IF APPLICABLE) FOR POSSIBLE PART NUMBER CHANGES.

Table 7-3. Parts List Interface Card 113771-001, 002, 003 (Continued)

Description and Manufacturer's Part No.	REMEX Part No.	Quantity	Reference Designation
Resistor, 470 ohm, 1/4W, ± 5%	701003-471	1 1 -	R12
Resistor, 3.3K, 1/4W, ± 5%	701003-102	3 3 2	R15, R19, R28
Resistor, 180 ohm, 1/2W, ± 5%	701004-181	1 1 1	R17
Resistor, 470K, 1/4W, ± 5%	701003-474	2 2 1	R20, R21
Resistor, 1K, 1/4W, ± 5%	701003-102	1 1 -	R R26
Resistor, 470 ohm, 1/2W, ± 5%	701004-471	1 1 -	R27
Resistor, Variable, 1M, 1/2W, Spectrol 53-1-1-105	701659-105	2 2 1	R23, R30
Screw Lock Assembly	706540-123	2 1 1	(J1, J2)
Socket, 40-Pin, Dip, Robinson Nugent ICN-406-S4-T	706515-139	1 1 1	Z6B
Switch, 1 Position, REMEX Specification	715059-191	- - 1	S1
Switch, 5 Position, REMEX Specification	715059-190	- 1 -	S1-S5
Switch, 8 Position, REMEX Specification	715059-189	1 - -	S1-S8
Switch, 5 Position, Dip, Molex 10040-105	715064-105	1 1 1	S9
Switch, 7 Position, Dip, Molex 10040-107	715064-106	1 1 1	S10
Test Point, Phoenix Tool 23-1669-11	706530-170	13 13 13	TP1-TP10 A1, A2, A3
Transistor, Motorola MPSA06	704203-118	3 3 1	Q1-Q3
Voltage Regulator, μA78MGUIC	704520-141	1 1 1	Z1
Voltage Regulator, μA79MGUIC	704520-142	1 1 1	Z2
Voltage Regulator, μA7805UC	704520-143	1 1 1	Z3

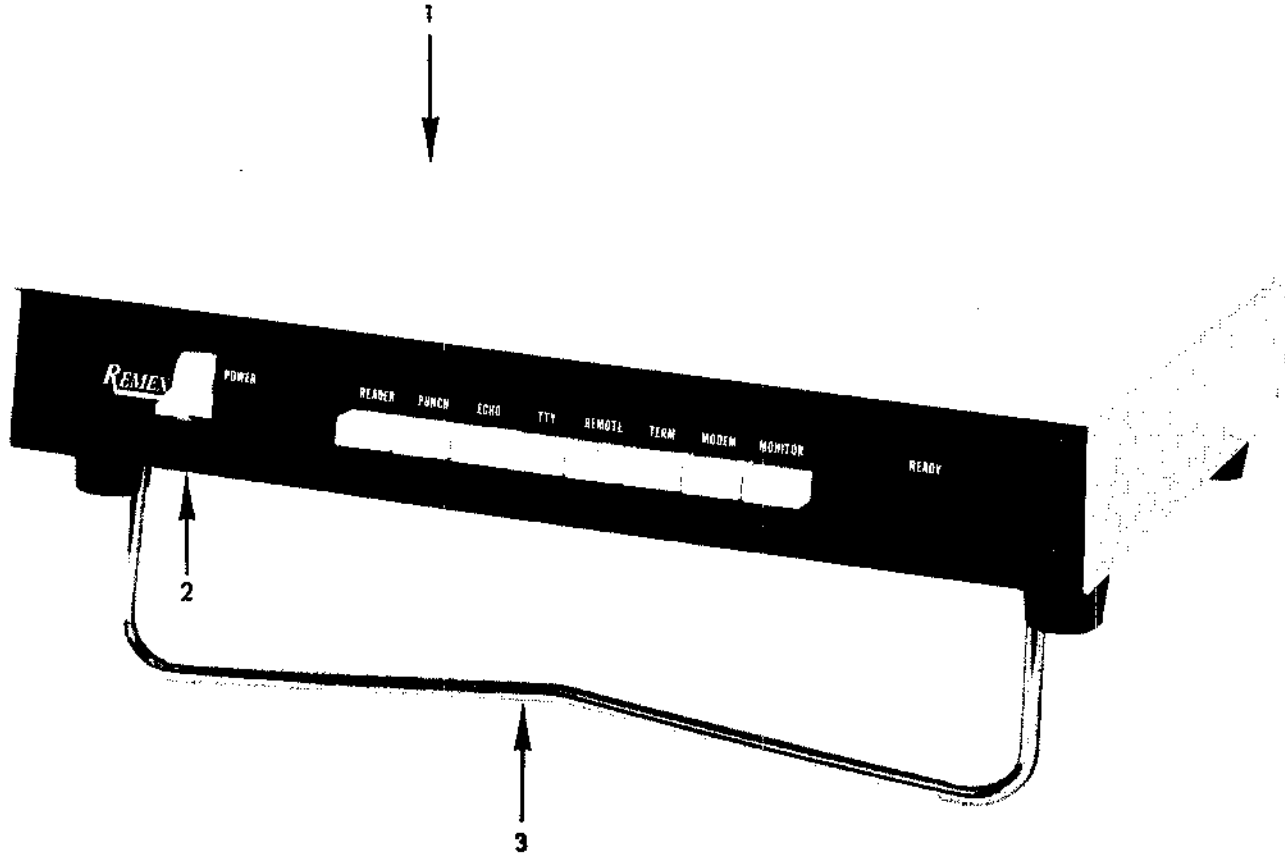

Figure 7-1. REMEX Interface, Model RJA2322.

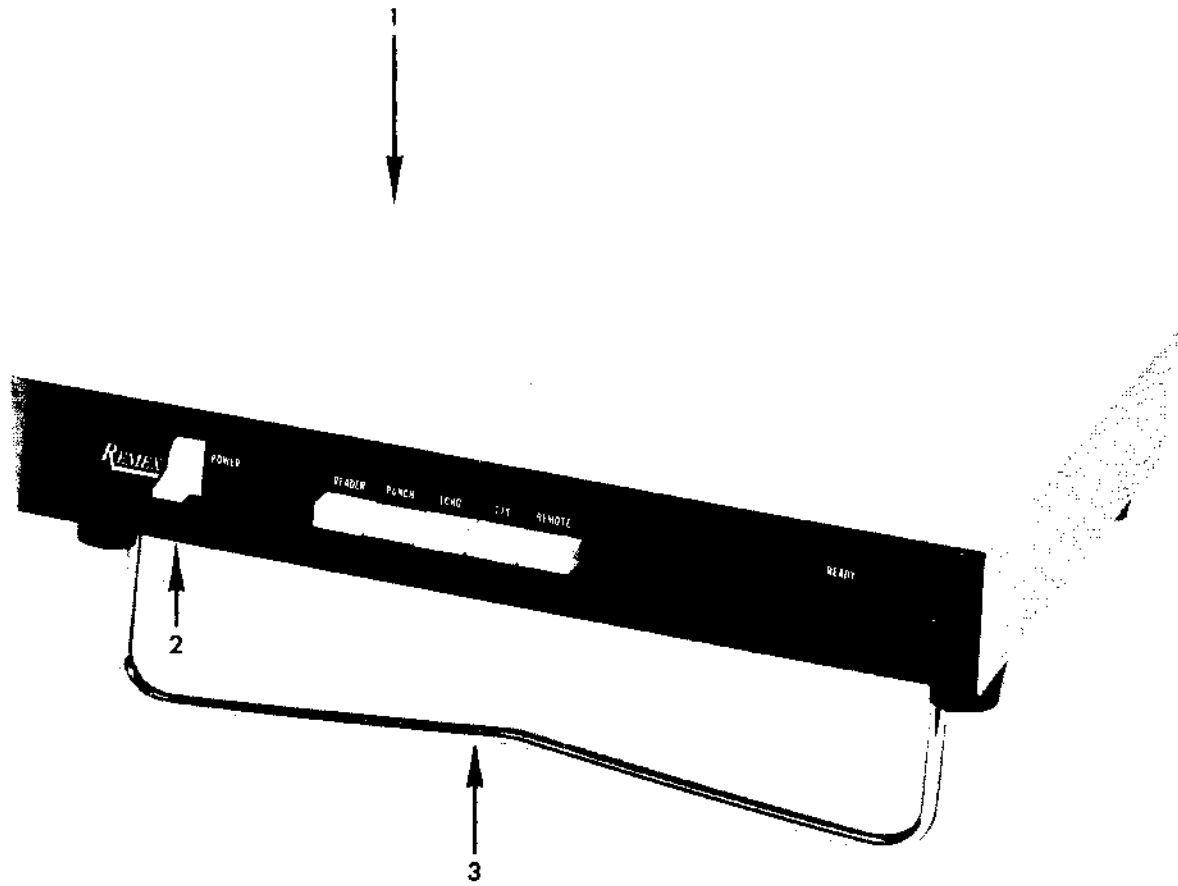

Figure 7-2. REMEX Interface, Model RJA2321.

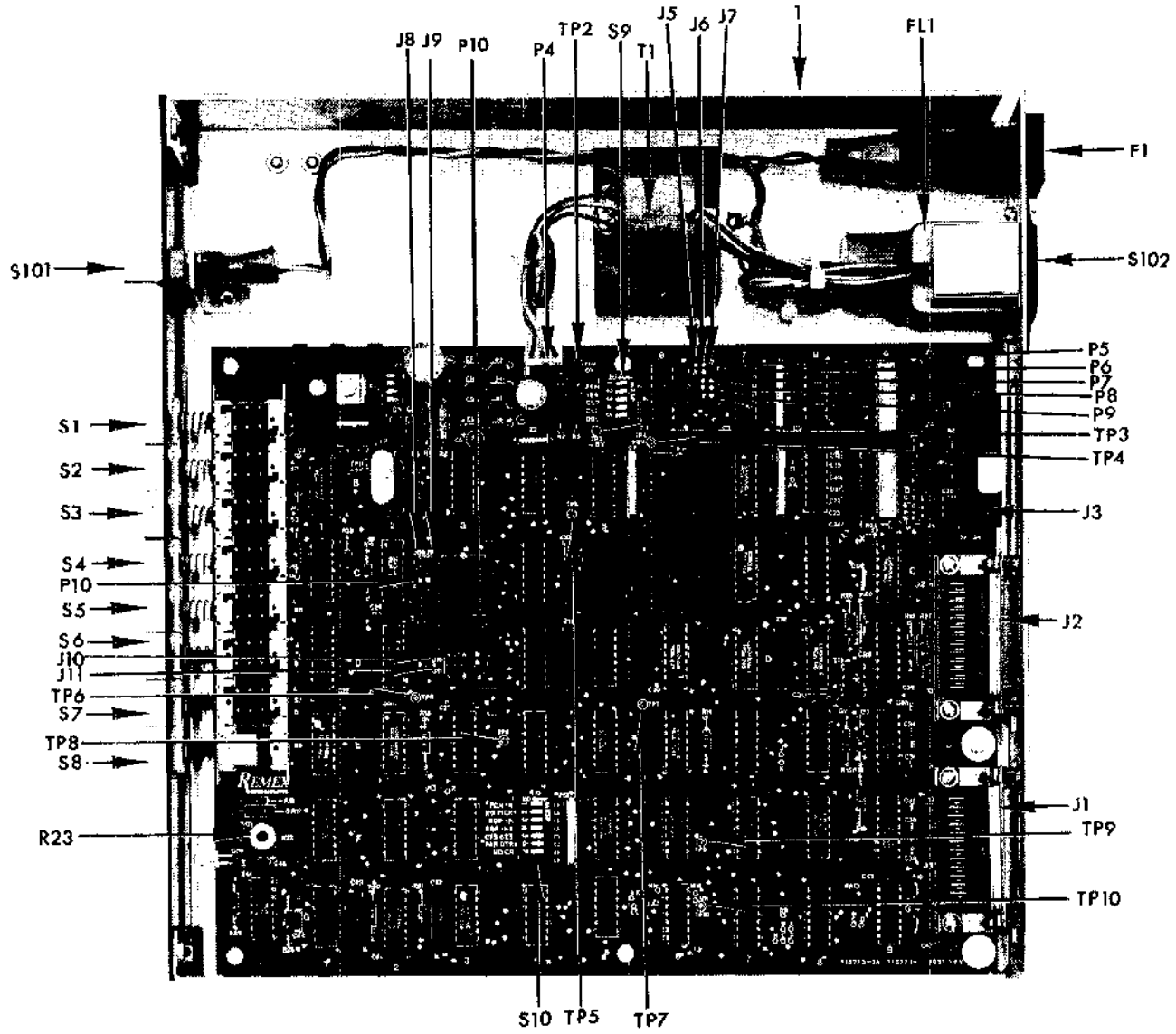

Figure 7-3. Chassis Assembly, Model RJA2322.

Photo Not Available at
Time of Printing

Figure 7-4. Chassis Assembly, Model RJA2321.

SECTION III

SCHEMATIC DRAWINGS

8.1 GENERAL

Figure 8-1 contains the schematic diagram for the RJX232X systems for revision A-C of card 113771-00X. Figure 8-2 contains the REMEX standard symbols used on the drawings. Figure 8-3 contains the schematic for the RJX232X system for revision D and higher of card 113771-00X.

SIGNAL INDEX (1)								
SIGNAL	SOURCE	ADDRESS	SIGNAL	SOURCE	ADDRESS	SIGNAL	SOURCE	ADDRESS
BS *	3D6	2C4	ECHO	4C1	4C4	RBR 1	2E3	3E7
			ECHO *	4C1	4E4	RBR 2	2E3	3E7
CRDY *	2B1	3D5	ETX *	2B4	3E6	RBR 3	2E3	3E7
						RBR 4	2E3	3D7
			ICTS	3C6	2B5	RBR 5	2E3	3D7
DB1	2EG	2CG	IDTR	5C4	4CG, 4D6	RBR 6	2E3	3D8
DB1 *	2EG	2CG	IRTS	3C2	2B5, 4E2	RBR 7	2E3	3C8
DB2	2EG	2CG, 2EG				RCLK	9E3	3A7
DB2 *	2EG	2CG				RCLK *	9E3	2A5, 2CG
DB3	2D6	2CG, 2EG	LOC	3C1	3E5, 3A2	RDEN	3D1	3D5
DB3 *	2D6	2B6				RDEN *	3D1	3D5
DB4	2D6	2B6, 2EG	MCTS	4D6	3C8	REM	3C1	2C4, 3C8, 3E5
DB4 *	2D6	2B6	MOD	4C1	3C8, 4C7, 4E7	RRI	4A3	2D6
DB5	2D6	2B6, 2EG	MR	2C3	2D6, 3D6, 2B3	RZLN	3D2	4E7
DB5 *	2D6	2B6	MR *	2B3	3E4, 3E4, 3D6	RZLN *	3D2	4E7
DB6	2CG	2EG	M/T	4B1	4B6, 4C7, 4E7	RZR	2A5	3B4, 5D4
DB6 *	2CG	2B6				SWRTS	3C7	4C5
DB7	2CG	2EG				TBRE	4D5	3B7
DB7 *	2CG	2B6				TBRL *	2A3	2D6
DB8	2CG	2EG	PHTO *	5C5	3E5	TERM	4B1	3C7, 4B6, 4C7, 4D7
DR	2D5	2C4, 3C8, 3D5, 3C7	PCLK	5D3	2D6, 3C7	TRE	2D5	3B4
DRDY	2B7	3B7	PCLK *	3D3	3D5	TRO	2D5	4B4, 4D6
DRDY *	2B7	3B5	PCMD	3C4	2C3	TTY	4D1	4A4
DRR *	3D4	2D6	PE	2D5	3D5	TTY *	4C1	4A4
DSR *	4CG	2A5						
			PEN *	3C1	3E5	WORDY	3B6	2B1
			PRDY	3D7	3C5			

JUMPING WIRE LIST (35)					
-1 ASSY		-2 ASSY		-3 ASSY	
FROM	TO	FROM	TO	FROM	TO
-	-	A	B	A	B
-	-	C	D	C	D
-	-	E	F	E	H
-	-	-	-	J	K
T	U	T	U	-	-
Y	W	V	W	-	-
-	-	-	-	X	Y
-	-	-	-	-	-
DD	EE	DD	EE	-	-
CC	EE	CC	EE	-	-
-	-	STA-C	STA-NO	STA-C	STA-NO
-	-	SSA-C	SSA-NC	SSA-C	SSA-NC
-	-	-	-	SSA-C	SSA-NC
-	-	-	-	-	-
-	-	-	-	5E-3	5E-10
-	-	-	-	-	-

- NOTE: UNLESS OTHERWISE SPECIFIED
- (1) THE THREE CHARACTER SOURCE/ADDRESS IS AS FOLLOWS:
SHEET NUMBER-VERTICAL ZONE-HORIZONTAL ZONE.
- CAPACITORS ARE 100V.
 - RESISTORS ARE 1/4W, ±5%.
 - CR1-4 ARE 704000-107 (IN30B9).
 - CR5 IS 704004-006 (LED).
 - Q1, Q2, Q3 ARE 704203-113 (MPSA06).
 - Z1 IS 704320-141.
 - Z2 IS 704320-142.
 - Z3 IS 704320-143.
 - Z4, 7, B, 13 ARE 701900-013.
 - E5, 6, 10, 11, 12 ARE 701900-007.
 - Z9A AND Z9B ARE 701900-014.
 - Z9 IS 704216-101.
 - Z1B, 2C, 2E, 6E, 7A, 7B ARE 704800-110 (4069).
 - Z1C, 3D, 7E, 8A, 8B, 8C ARE 704800-105 (4090G).
 - Z1D, 2D, 3E, 6F, 8F ARE 704810-106 (4013).
 - Z1E, 3G ARE 704800-113 (4073).
 - Z1F, 7F ARE 704800-108 (4011).
 - Z1G, 3F, 4G, 8E ARE 704800-111 (4071).
 - Z2F, 3B, 4E, 5G, 6G 704800-112 (4081).
 - Z2G, Z14 ARE 704810-113 (4528).
 - Z3C IS 704810-114 (14411).
 - Z4B, 6A ARE 704800-109 (4068).
 - Z4C, 7G, 8G ARE 704810-109 (4019).
 - Z4D, 5S 704810-112 (4044).
 - Z5B IS 704800-115 (4090).
 - Z5C IS 113379-001.
 - Z5E, 5F ARE 704810-111 (4085).
 - Z6B IS 704810-115 (1M6402A).
 - Z6D IS 704800-114 (4082).
 - Z7C IS 704800-107 (4001).
 - Z7D, 8D, 9C IS 704800-103 (4049).
 - Z9D, 9G ARE 704610-175 (75189).
 - Z9E, 9F ARE 704610-174 (75188).
- (35) SEE WIRE LIST FOR JUMPERS.
- (36) -001 ASSY ONLY.
- (37) -001 & -002 ASSEMBLIES ONLY.
38. REF ASSY DWG 113771-*.
39. CRG IS 704000-110 (FDH6666)

SPARES:

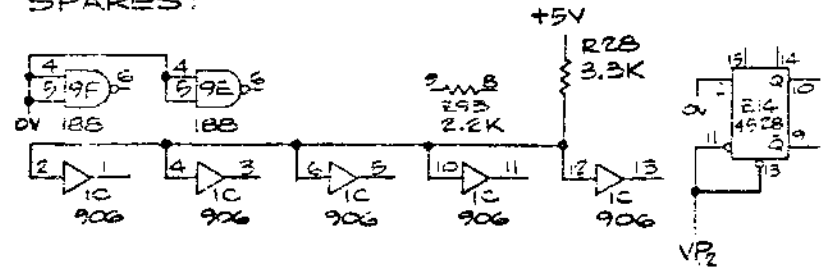

LAST DESIGNATION USED	UNUSED
CAPACITOR C47	C10-17
DIODE CRG	
INTEGRATED CIRCUIT Z9G	
RESISTOR R28	
TRANSISTOR Q3	

RJX232X	-
RAR20511	-
RPR20511	-
USED ON NEXT ASSY	

REVISION STATUS		
SCHEM	FAB	ASSY
A	A	A

Figure 8-1. Schematic RJX232X, Card 113771-001, -002 and -003. Revs A-C.

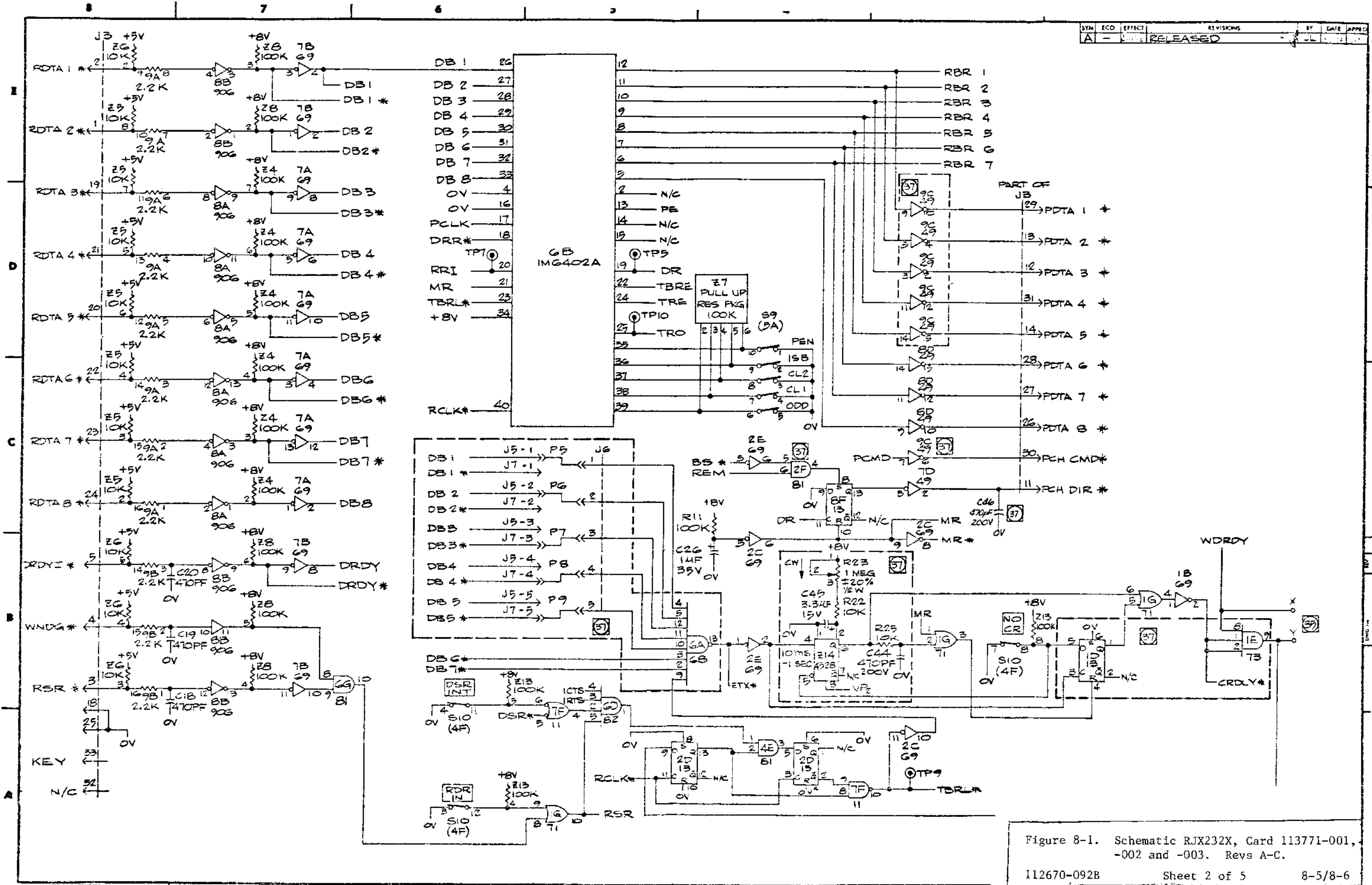

Figure 8-1. Schematic RJX232X, Card 113771-001, -002 and -003. Revs A-C.
112670-092B Sheet 2 of 5 8-5/8-6

SYM	ECO	EFFECT	REVISIONS	BY	DATE	APPR
A	-	RELEASED		JL		

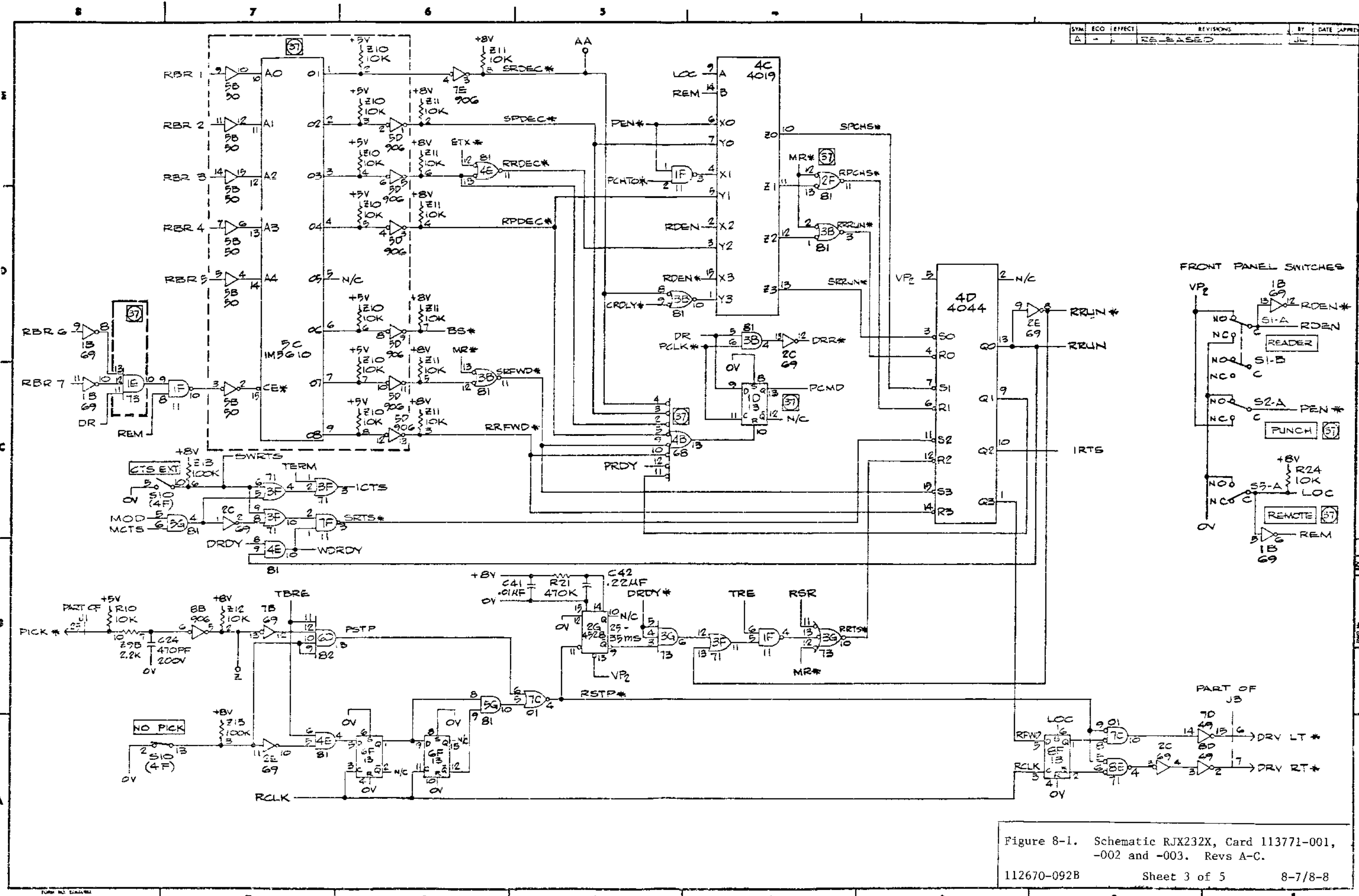
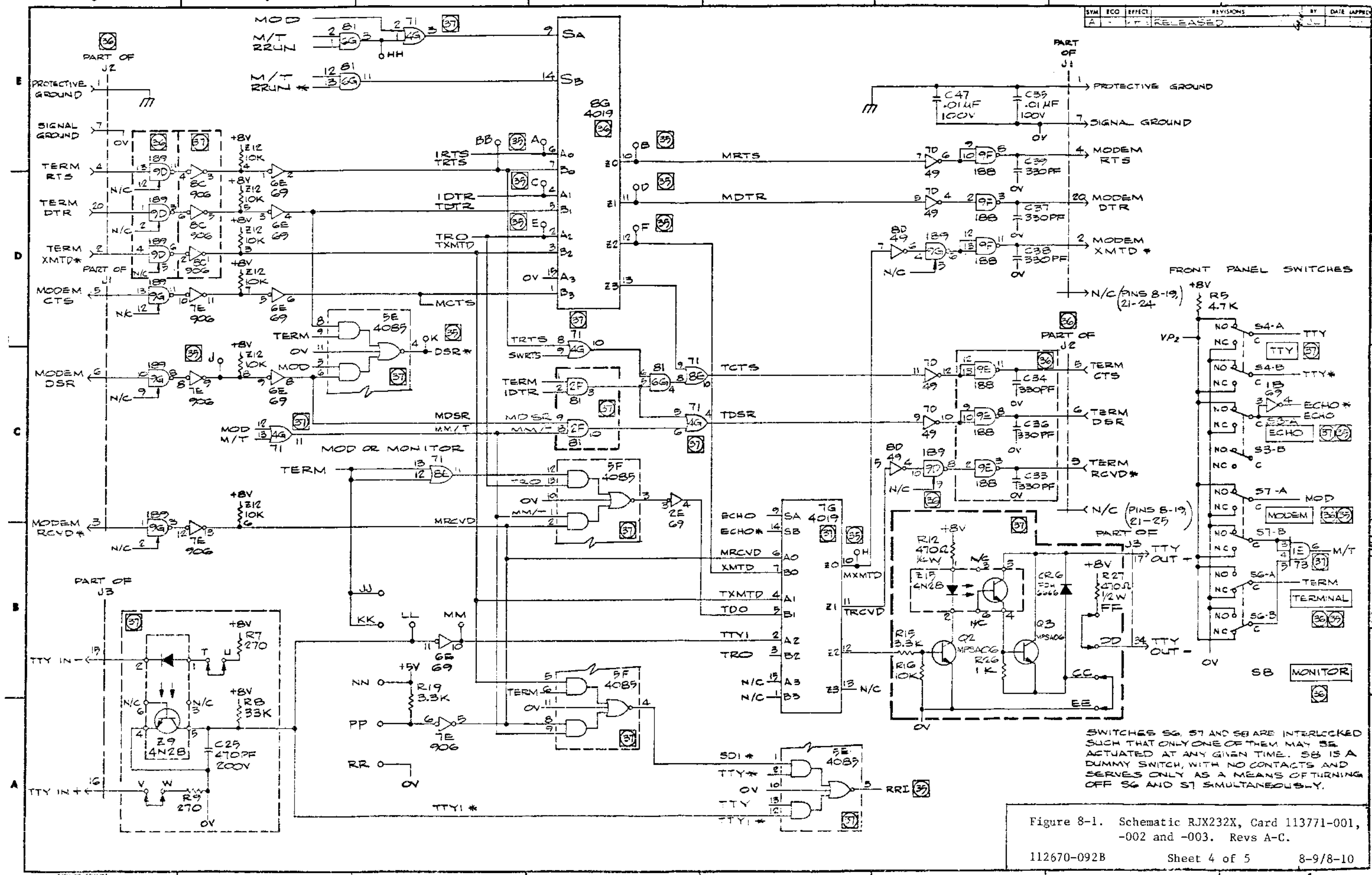

Figure 8-1. Schematic RJX232X, Card 113771-001, -002 and -003. Revs A-C.
112670-092B Sheet 3 of 5 8-7/8-8

SYM	ECO	EFFECT	REVISIONS	BY	DATE	APPROV
A	-	-	RELEASED			



SWITCHES S6, S7 AND S8 ARE INTERLOCKED SUCH THAT ONLY ONE OF THEM MAY BE ACTUATED AT ANY GIVEN TIME. S8 IS A DUMMY SWITCH, WITH NO CONTACTS AND SERVES ONLY AS A MEANS OF TURNING OFF S6 AND S7 SIMULTANEOUSLY.

Figure 8-1. Schematic RJX232X, Card 113771-001, -002 and -003. Revs A-C.
112670-092B Sheet 4 of 5 8-9/8-10

STN	ECO	EFFECT	REVISIONS	BY	DATE	APPROV
A	-	RELEASED				

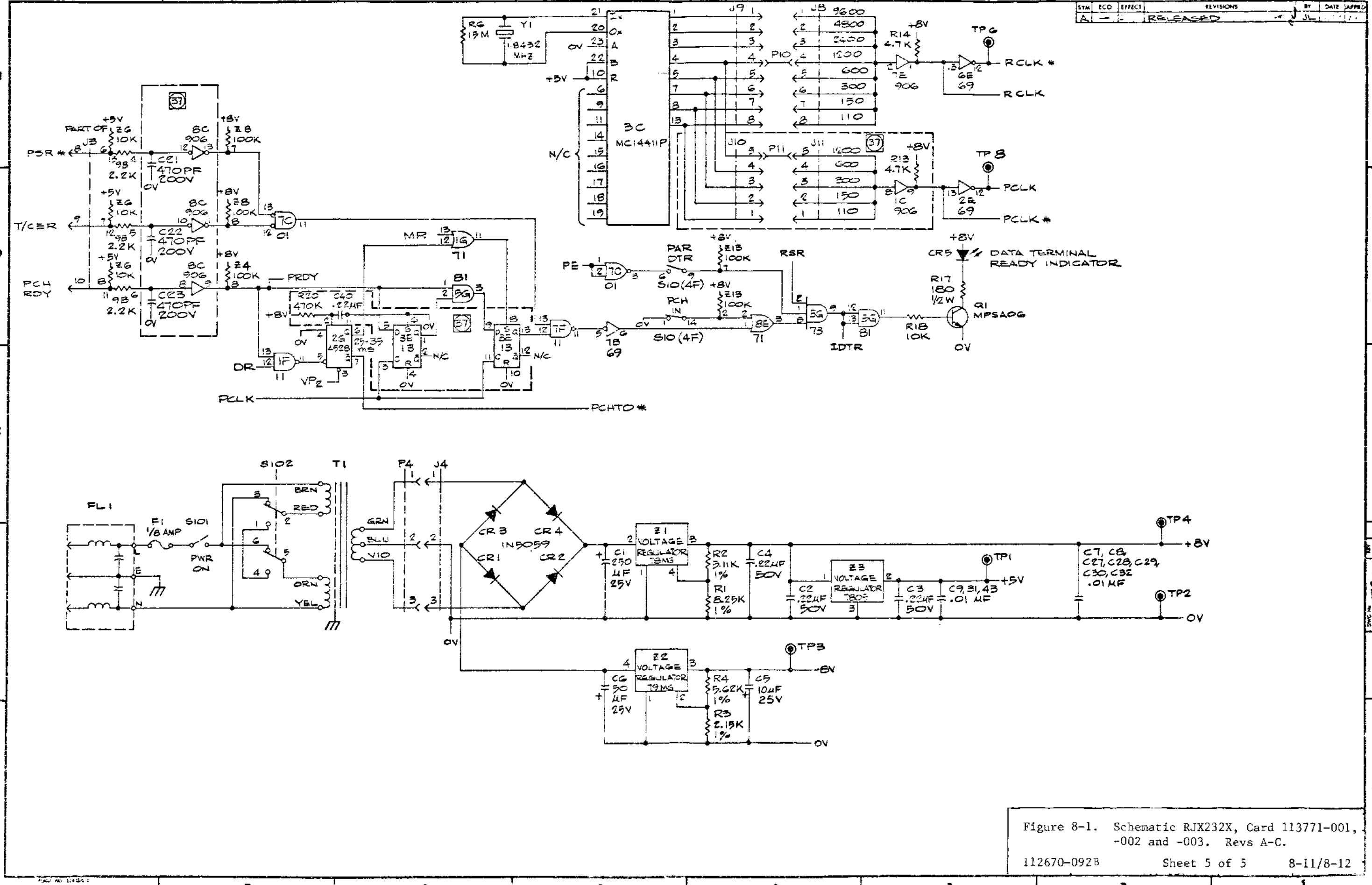

Figure 8-1. Schematic RJX232X, Card 113771-001, -002 and -003. Revs A-C.
112670-092B Sheet 5 of 5 8-11/8-12

COMPONENT & REF DESIGNATOR	SYMBOL	REMARKS	COMPONENT & REF DESIGNATOR	SYMBOL	REMARKS
SWITCH, 'S'	S1		Z INTEGRATED CIRCUIT PACKAGE POSITIVE TRUE LOGIC SYMBOLS Z LOGIC FUNCTION DESIGNATORS PER MANUFACTURER'S SPECIFICATIONS	NAND NOR AND OR EXCLUSIVE OR INVERTER AMPLIFIER	Z XX INDICATES I.C. Pkg. LOCATION ON P.C. CARD (LEFT TO RIGHT TOP TO BOTTOM SEQUENCE) Z XX Y INDICATES I.C. Pkg. LOCATION ON P.C. CARD IN XY COORDINATE SYSTEM (X=NUMBER, Y=LETTER) Z EITHER NUMBERING SYSTEM SHOWN ABOVE MAY BE USED DEPENDING ON SIZE OR COMPLEXITY OF P.C. CARD
SAFETY INTERLOCK	S2 (N.C.)				
LIMIT SW.	S3 (N.O.) S4 (N.C.) S5 (N.O.) S6 (N.C.) S7 (N.O.) S8 (N.C.) S9 (N.O.) S10 (N.C.)				
POWER	P1 (PWR ON) P2 (PWR OFF)				
PUSH BUTTON, 'PB'	PB1 (N.O.) PB2 (N.C.)				
TRANSFER	T1 (SPOT) T2 (3 POSITION CENTER OFF)				
TIMER CONTACTS	DE-ENERGIZED ENERGIZED				
TRANSISTOR, 'Q'	Q1 (PNP) Q2 (NPN)				
VJT, 'Q'	Q3 (N-TYPE) Q4 (P-TYPE)	ARROW POINTS TOWARD BI FOR 'N' TYPE & AWAY FROM BI FOR 'P' TYPE			
FET, 'Q'	Q5 (N-TYPE) Q6 (P-TYPE)				
DIODE, 'CR' or 'D'		* USE 'D' ON N/C APPLICATIONS			
ZENER DIODE, 'CR'	XXV	V = VOLTS			
TRIAC		INDICATE TERMINALS 1 AND 2			
SCR					
BRIDGE RECTIFIER, 'BR' or 'D'		* USE 'D' ON N/C APPLICATIONS			
CABLE RUN (OPTIONAL)	X1, X2, X3, X4, X5, X6, X7, X8, X9, X10				
CABLE, 2 OR MORE CONDUCTORS		IF SHIELDED CONDUCTOR SHOW TERMINATION OF SHIELD			
THISTED WIRES	PAIR, TRIPPLE				
COAXIAL CABLE					

Figure 8-2. REMEX Standard Schematic Symbols, Sheet 1 of 2.

COMPONENT # REF DESIGNATOR	SYMBOL	REMARKS	COMPONENT # REF DESIGNATOR	SYMBOL	REMARKS
CAPACITOR 'C'		GIVE VOLTAGE ON ELECTROLYTICS, MOTOR AND A.C. CAPACITORS IN A.C. CIRCUITS, VOLTAGE OPTIONAL FOR ALL OTHERS.	TERMINAL 'E'		USE % LOGICAL DESCRIPTION OR BOTH
CELL, PHOTOSENSITIVE 'V'					
GND					
COIL RELAY 'K' OR NUMERICAL DESIGNATOR CONTACTS					
CONTACT CONNECTOR 'P', 'J'					
SEPARABLE CONNECTORS, ENGAGED		DEFINITION: PLUS: USUALLY MOVABLE JACK: USUALLY STATIONARY REVERSE: IDENTIFIC. PLUS: — JACK: —			
CONNECTORS, AC POWER 'P', 'J'					
FUSE, 'F'					
INDUCTOR, VARIOUS 'L' REACTOR, OR SOLENOID		GIVE INDUCTANCE OR COVER IN NOTES			
TRANSFORMER		POLARITY DOTS TO BE SHOWN IF NECESSARY TO CIRCUIT FUNCTION			
LAMP, INDICATING 'DS'					
CRYSTAL, 'Y'					
BOARD, TERMINAL 'TB' OR FANNING STRIP 'YS'					
EDGELET, PC CARD					
TEST POINT, 'TP'					
JUMPER WIRE, PC		FOR OPTIONAL WIRING			
RESISTOR, FIXED, VARIABLE 'R'		OPTIONAL ADJUSTMENT SYMBOL: SCREW DRIVER KNOW VALUE AND TOLERANCE TO BE SHOWN OR PUT IN NOTES			
LAMP, GLOW 'N'					
LINE CROSS					
LINE CONNECT					

STANDARD SCHEMATIC SYMBOLS
107700

107700

Figure 8-2. REMEX Standard Schematic Symbols, Sheet 2 of 2.

SYM	ECO	EFFECT	REVISIONS	BY	DATE	APPROV
A	-	-	RELEASED			
N	REC-321	-	UPDATED REV STATUS		6-27-84	
B	19959	-	CHANGE ALLS CTS SWITCH READER		6-27-84	
C	19274	280	UPDATE REV STATUS		6-27-84	
D	19485	281	INITIAL SWITCH ON RES30 BUS		6-27-84	
E	19281	281	REVISED WIRE LIST		6-27-84	
F	19016	281	UPDATE REV STATUS		6-27-84	

SIGNAL INDEX (1)								
SIGNAL	SOURCE	ADDRESS	SIGNAL	SOURCE	ADDRESS	SIGNAL	SOURCE	ADDRESS
BS *	3D6	2C4	ECHO	4C1	4C4	RBR 1	2E3	3E7
			ECHO *	4C1	4B4	RBR 2	2E3	3E7
CRDY *	2B1	3D9	ETX *	2B-	3E6	RBR 3	2E3	3E7
						RBR 4	2E3	3D7
			ICTS	3C6	2B9	RBR 5	2E3	3D7
DB1	2EG	2CG	IDTR	3C4	4C6, 4D6	RBR 6	2E3	3DB
DB1 *	2EG	2CG	IRTS	3C2	2B9, 4E6	RBR 7	2E3	3CB
DB2	2EG	2CG, 2EG				RCLK	5E3	3A7
DB2 *	2EG	2CG				RCLK *	5E3	2A9, 2CG
DB3	2DG	2CG, 2EG	LOC	3C1	3E3, 3A2	RDEN	3D1	3D9
DB3 *	2DG	2B6				RDEN *	3D1	3D9
DB4	2DG	2B6, 2EG	MCTS	4D6	3CB	REM	3C1	2C4, 3CB, 3E5
DB4 *	2DG	2B6	MOD	4C1	4C7, 4E6	RRI	4A3	2DG
DB5	2DG	2B6, 2EG	MR	2C3	2CG, 5D6, 2B3			
DB5 *	2DG	2B6	MR *	2B3	3B4, 3E4, 3D6	RSR	2A5	3E4, 3D4
DB6	2CG	2EG	M/T	4B1	4B6, 4C7, 4E6	SWRTS	3C7	4C9
DB6 *	2CG	2B6	MM/T	4A6	3CB, 4C7	TBRL	2A3	3A6
DB7	2CG	2EG				TBRL *	2A3	2DG
DB7 *	2CG	2B6	PCHTO *	5C5	3E5	TERM	4B1	3C7, 4B6, 4C7, 4D7
DB8	2CG	2EG	PCLK	5D3	2DG, 3C7	TRE	2D9	3B4, 3B7, 2A6
DR	2D9	2C4, 3CB, 3D9, 3C7	PCLK *	5D3	3D9	TRO	2D9	4E4, 4E7
DRDY	2B7	3B7	PCMD	3C4	2C3	TTY	4D1	4A4
DRDY *	2B7	3B5	PE	2D9	3D9	TTY *	4C1	4A4
DRR *	3D4	2DG	PICK	3A7	2B6			
DSR *	4CG	2A5	PEN *	3C1	3E5	WDROY	3B6	2B1
			PRDY	3D7	3C5			

JUMPERING WIRE LIST (36)					
-1 ASSY		-2 ASSY		-3 ASSY	
FROM	TO	FROM	TO	FROM	TO
-	-	A	B	A	B
-	-	C	D	C	D
-	-	E	F	E	F
-	-	-	-	J	K
T	U	T	U	-	-
V	N	V	N	-	-
-	-	-	-	X	Y
-	-	-	-	-	-
DD	FF	DD	FF	TT	VV
CC	EE	CC	EE	UU	WW
-	-	STA-C	STA-NO	STA-C	STA-NO
-	-	SGA-C	SGA-NC	SGA-C	SGA-NC
-	-	-	-	SBA-C	SBA-NC
-	-	-	-	3E-3	3E-10
-	-	-	-	-	-

- NOTE: UNLESS OTHERWISE SPECIFIED
- (1) THE THREE CHARACTER SOURCE/ADDRESS IS AS FOLLOWS:
SHEET NUMBER: VERTICAL ZONE - HORIZONTAL ZONE.
- CAPACITORS ARE 100V.
 - RESISTORS ARE 1/4W, 5%.
 - Z1, Z2 ARE 704000-107 (N5059).
 - CR9 IS 704004-006 (LED).
 - Q1, Q2, Q3 ARE 704203-118 (MPSA06).
 - Z1 IS 704520-141.
 - Z2 IS 704520-142.
 - E3 IS 704520-143.
 - Z4, Z5, Z6 ARE 701900-019.
 - Z7, Z8, Z9 ARE 701900-007.
 - Z9A AND Z9B ARE 701900-014.
 - Z9 IS 704216-101.
 - Z1B, Z2, Z5, Z6, Z7A, Z7B ARE 704800-110 (4069).
 - Z1C, Z1D, Z1E, Z1F, Z1G, Z1H ARE 704800-105 (740906).
 - Z1D, Z1E, Z1F, Z1G, Z1H ARE 704810-106 (4013).
 - Z1E, Z1G ARE 704800-113 (4073).
 - Z1F, Z1H ARE 704800-108 (4011).
 - Z1G, Z1H, Z1I, Z1J ARE 704800-111 (4071).
 - Z1K, Z1L, Z1M, Z1N ARE 704800-112 (4081).
 - Z1O, Z1P ARE 704810-113 (4528).
 - Z1Q IS 704810-114 (14411).
 - Z1R, Z1S ARE 704800-109 (4068).
 - Z1T, Z1U, Z1V ARE 704810-109 (4019).
 - Z1W IS 704810-112 (4044).
 - Z1X IS 704800-113 (4090).
 - Z1Y IS 113379-001.
 - Z1Z, Z1AA ARE 704810-111 (4085).
 - Z1AB IS 704810-113 (1M6402A).
 - Z1AC IS 704800-114 (4082).
 - Z1AD IS 704800-107 (4001).
 - Z1AE, Z1AF, Z1AG ARE 704800-103 (4049).
 - Z1AH, Z1AI ARE 704610-175 (75189).
 - Z1AJ, Z1AK ARE 704610-174 (75188).

- (35) SEE WIRE LIST FOR JUMPERS.
- (36) -001 ASSY ONLY.
- (37) -001 & -002 ASSEMBLIES ONLY.
38. REF ASSY DWG 113771-*.
39. CR6 IS 704000-110 (FDH6666)

SPARES:

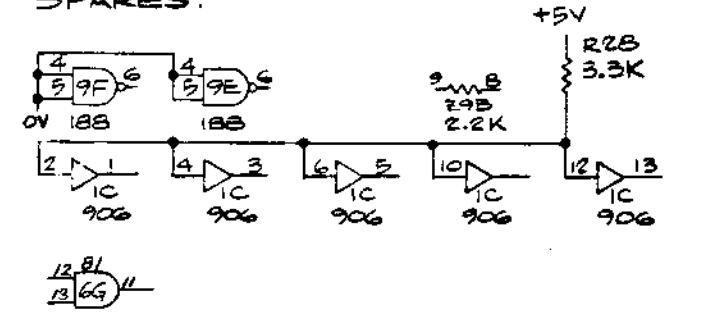

LAST DESIGNATION USED	UNUSED
CAPACITOR C4B	C10-17
DIODE CR6	
INTEGRATED CIRCUIT Z9G	
RESISTOR R30	
TRANSISTOR Q3	

RJX232X	-
RAR3051	-
RPR3051	-
USED ON NEXT ASSY	

REVISION STATUS		
SCHEM	FAB	ASSY
A	A	A
A	A	B
B	A	C
C	A	C ₁
D	A	C ₂
E	A	C ₃
-	B	-
F	C	D
F	D	D

Figure 8-3. Schematic RJX232X, Circuit Card Assembly 113771-001, -002 and -003. Revs D and above.

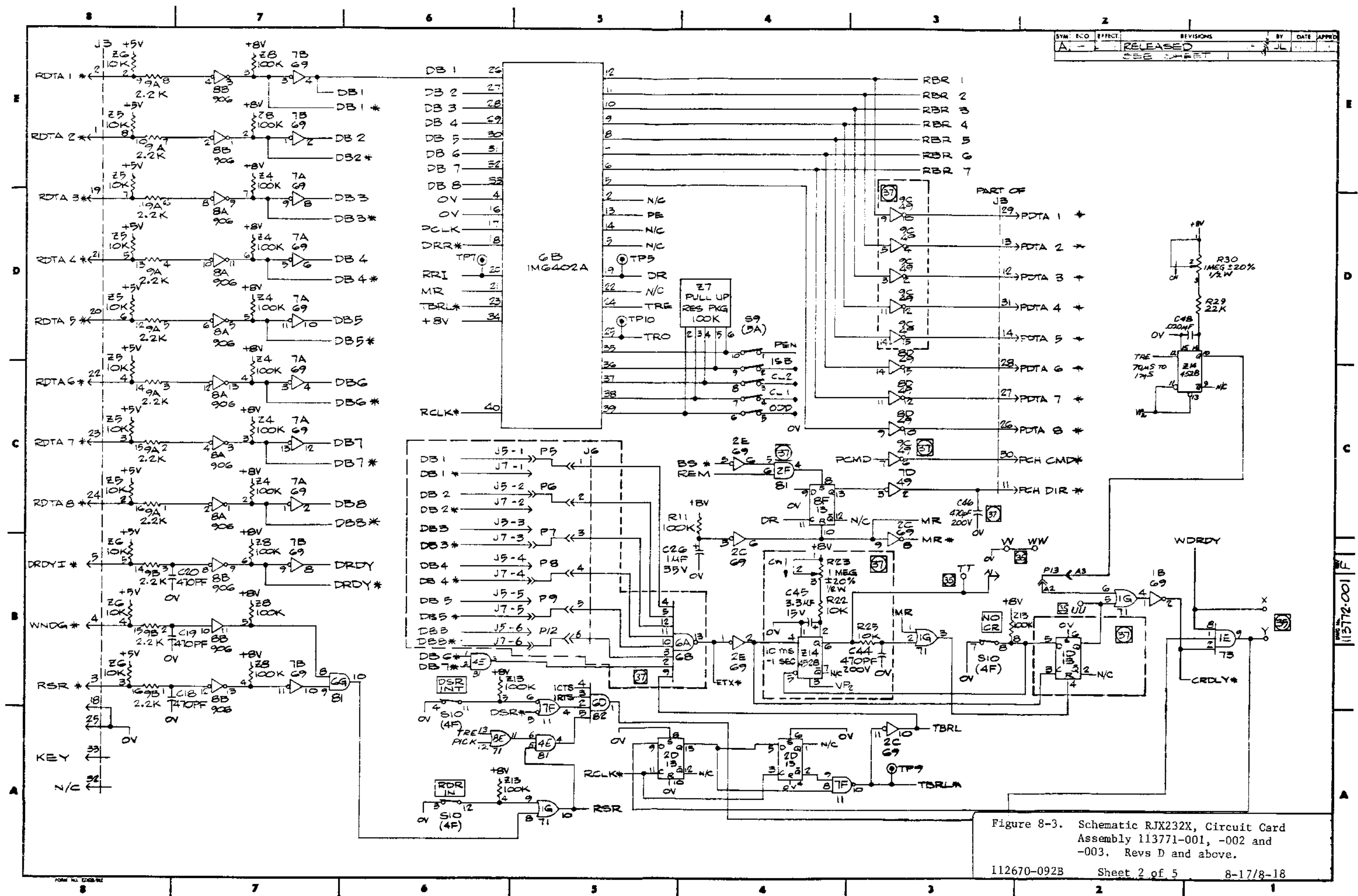

Figure 8-3. Schematic RJX232X, Circuit Card Assembly 113771-001, -002 and -003. Revs D and above.

SYM	ECO	EFFECT	REVISIONS	BY	DATE	APPROV
A	-	RELEASED		JL		
		SEE SHEET				

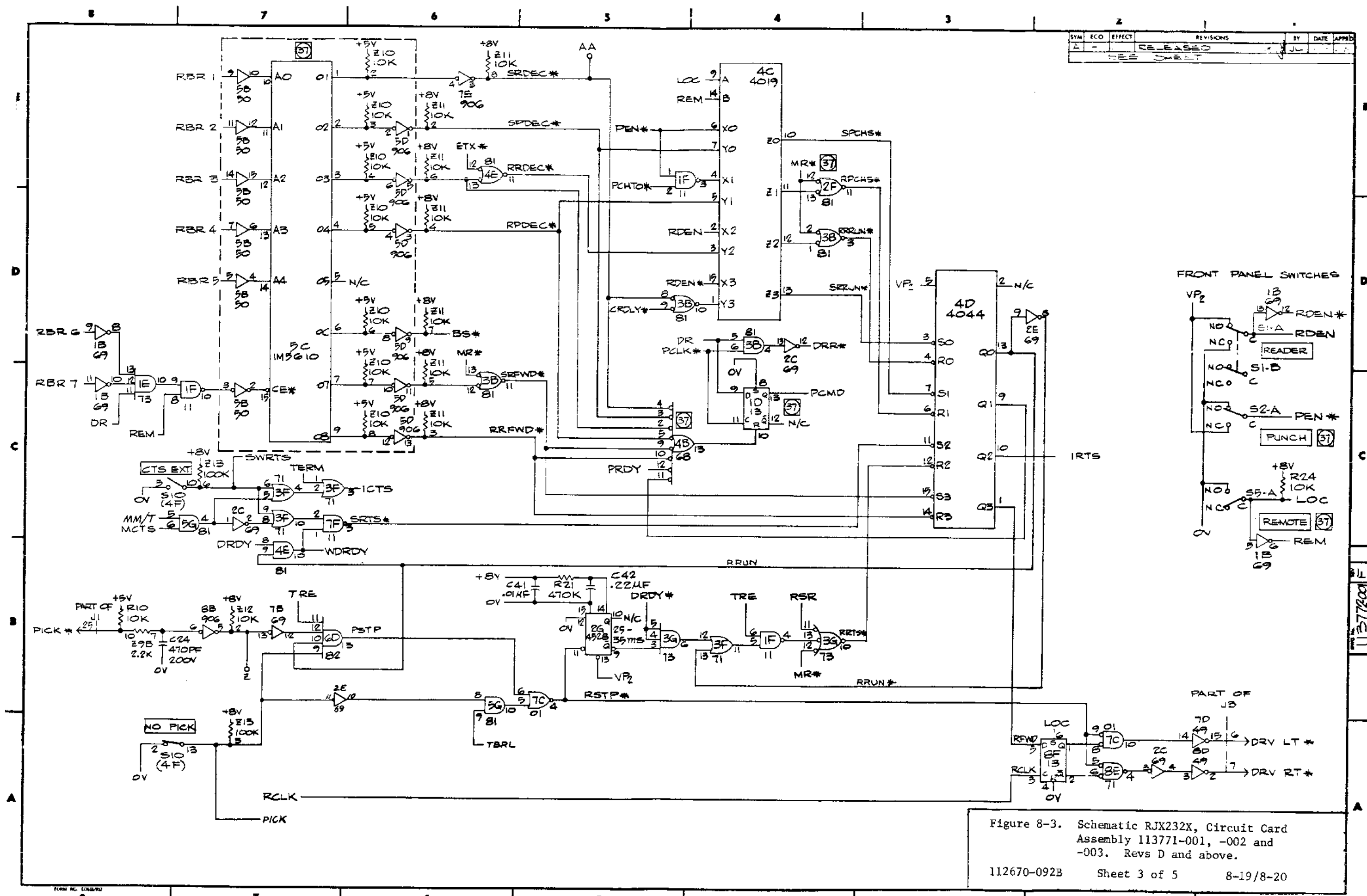

Figure 8-3. Schematic RJX232X, Circuit Card Assembly 113771-001, -002 and -003. Revs D and above.
 112670-092B Sheet 3 of 5 8-19/8-20

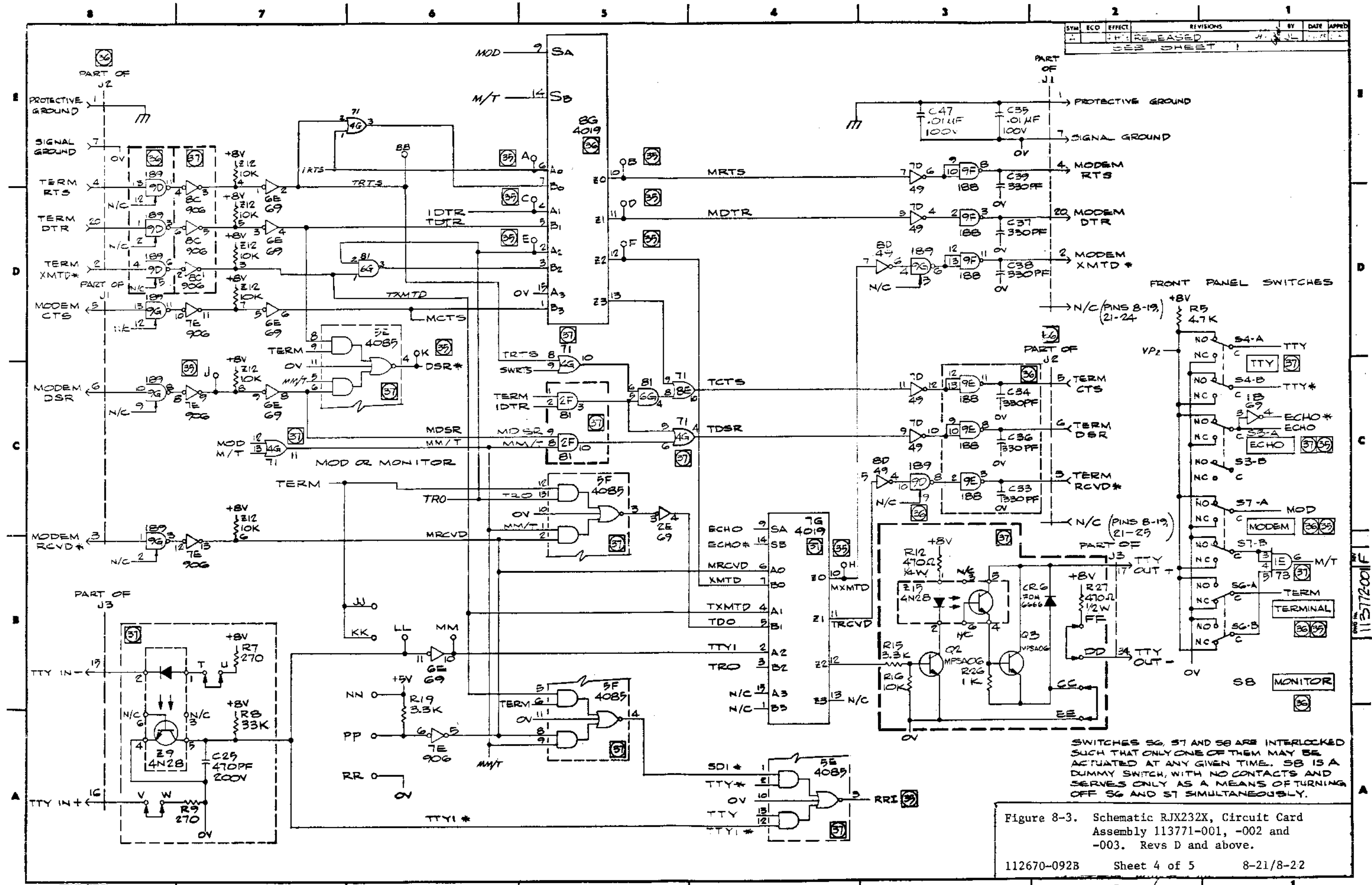

Figure 8-3. Schematic RJX232X, Circuit Card Assembly 113771-001, -002 and -003. Revs D and above.
112670-092B Sheet 4 of 5 8-21/8-22

SYM	ECO	EFFECT	REVISIONS	BY	DATE	APPROV
A	-	RELEASED				
		SEE SHEET 1				

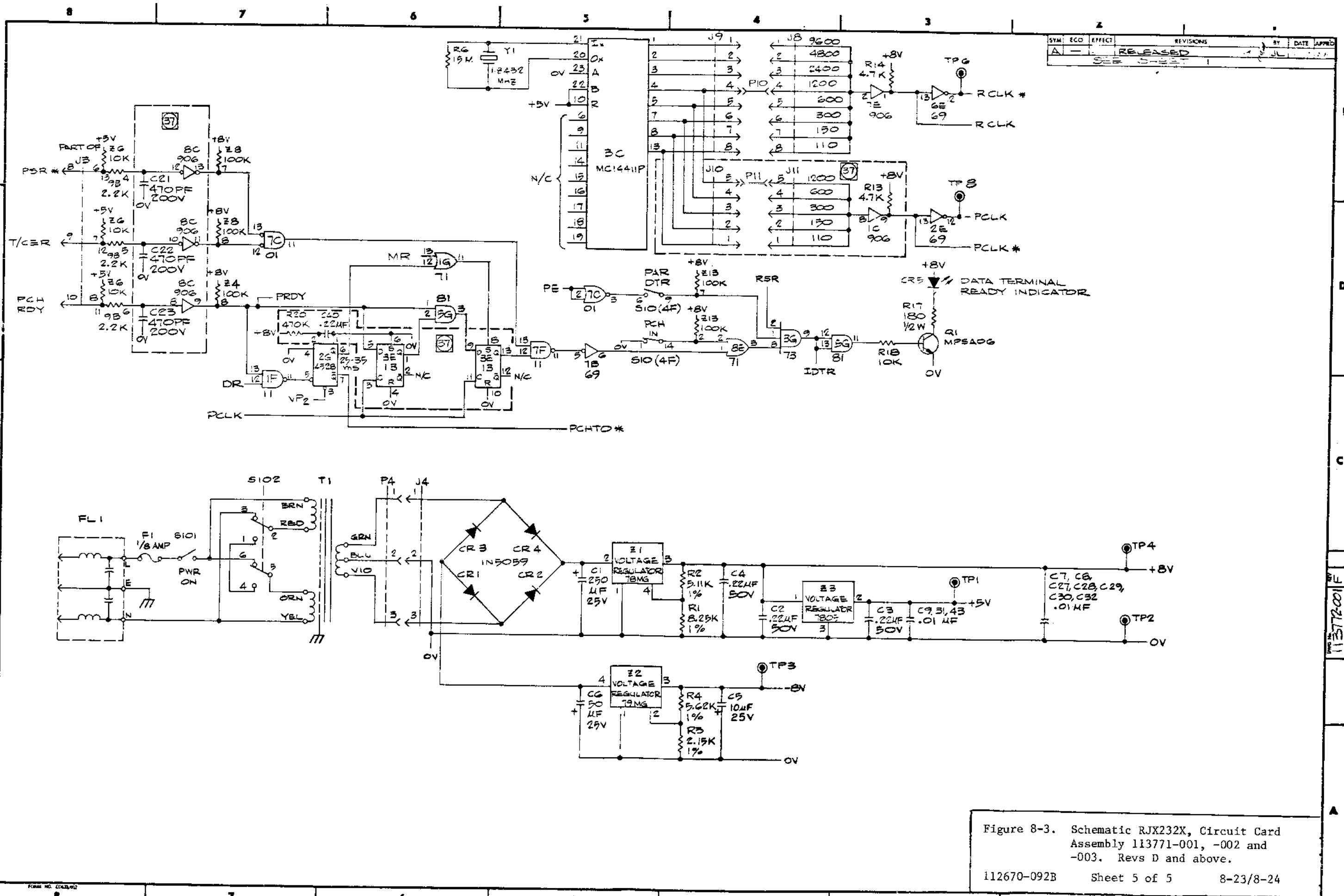

Figure 8-3. Schematic RJX232X, Circuit Card Assembly 113771-001, -002 and -003. Revs D and above.
112670-092B Sheet 5 of 5 8-23/8-24

ADDENDUM SHEET

THE FOLLOWING CHANGES IN THE MANUAL ARE REQUIRED:

1. A copy of drawing 113772-001 replaces Figure 8-3, sheets 1-5.
2. On Page 1-1, Paragraph 1.1, Sentence 1, Line 2 change:
RJR231 to RJR2321
3. On Page 2-3, add the following to CAUTION:
Damage may occur if 230 VAC is applied with unit set for 115 VAC operation.
4. On Page 3-4, Table 3-3, delete all phrases in column (2), column (1) shows designations of deletions. See Table below:

CONTROL/ SWITCH (1)	Deletions (2)
Stop Bit Select 1SB	(lever pointing toward 1SB lettering).
Even/Odd Parity (ODD)	(lever pointing to the ODD lettering).
Punch Connection (PCH IN)	(lever pointing toward PCH IN lettering).
Pick Option (NO PICK)	(lever pointing away from the NO PICK lettering).
Reader Connection (RDR IN)	(lever pointing toward RDR IN lettering).
Data Set Ready Internal/External (DSR INT)	(lever pointing away from the DSR INT lettering).
Clear to Send Internal/External (CTS EXT)	(lever pointing to CTS EXT lettering).
Data Terminal Ready Disable During Parity Error (PAR DTR)	(lever pointing toward the PAR DTR lettering).
Carriage Return Delay Enable (NO CR)	(lever pointing away from the NO CR lettering).

ADDENDUM (Cont'd)

5. On Page 3-4, Table 3-3, delete "NOTE" in Description Section on Character Length Switches (CL1,CL2). (NOTE is no longer true).
6. On Page 3-18, Figure 3-5, make the following changes on MMC 745 Dwg:
 - (a) In Case 1: delete wiring from J3 pin 16 to J3 pin 34.
(Wiring is not necessary).
 - (b) In Case 2: change J2 pin 6 to J2 pin 4.
 - (c) In Case 2: delete (OR MODEM PORT).
 - (d) In Case 2: change phrase; "installed in J1" to "installed in J2".
 - (e) In Case 3: change J1 pin 6 to J1 pin 4.
 - (f) In Case 1: add to ACTION REQ'D Column: CTS EXT must be OFF.

P.C. CARD CHANGE RECORD

CARD ASSY NO. 113771-001,002,003
 SCHEMATIC NO. 113772-002

112670-092B
 RIA-2327

SCH REV	ASSY REV	FAB REV	DESCRIPTION OF CHANGE
G	E	D	On sheet 2: Deleted R25, C44, Z1G-1, 2, 3, and Z1D. Added Z9E-4, 5, 6 which ties to Z14-13.
			On sheet 3: Tied EKP* signal to Z7B-13.
			On sheet 4: Added Z6G-11, 12, 13 between Z6E-4 and Z8G-5. Tied Z8G-4 to Z6C-12 and Z6E-4 to Z6G-13 and Z6G-11 to Z8G-5. Replaced MM/T signal at Z2F-8 and Z5F-1 with M/T signal.
G ₁	E	E	No change; updated revision status block.
G ₂	F	F	No change; updated revision status block.

SIGNAL INDEX								
SIGNAL	SOURCE	ADDRESS	SIGNAL	SOURCE	ADDRESS	SIGNAL	SOURCE	ADDRESS
BS*	300	204	ECHO	401	404	RBR 1	2E3	3E7
			ECHO*	401	404	RBR 2	2E3	3E7
CRDY*	2E4	305	ETX*	2B4	3E6	RBR 3	2E3	3E7
						RBR 4	2E3	3D7
			CTS	306	2B5	RBR 5	2E3	3D7
DB1	2E6	206	DTR	304	406, 406	RBR 6	2E3	3DB
DB1*	2E6	206	RTS	302	2B5, 2E6	RBR 7	2E3	308
DB2	2E6	206, 2E6				RLK	5E3	3A7
DB2*	2E6	206				RCLK*	5E3	2A5, 206
DB3	206	206, 2E6	LOC	301	3E5, 3A2	RDEN	3D1	3D5
DB3*	206	2B6				RDEN*	3D1	3D5
DB4	276	2B6, 2E6	MCTS	406	308	REM	301	204, 308, 3E5
DB4*	276	2B6	MOD	401	407, 4E6	RRI	4A3	2D6
DB5	276	2B6, 2E6	MR	203	2D6, 306,			
DB5*	276	2B6	MR*	2B3	3B4, 3E4, 306			
DB6	206	2E6	M/T	4A1	405, 407, 4E6	RSR	2A5	3B4, 374
DB6*	206	2B6	MM/T	4A6	308, 407	SWTS	307	407
DB7	206	2E6				TBRL	2A3	3A6
DB7*	206	2B6				TBR*	2A3	2D6
DB8	206	2E6	PCHT*	305	3E5	TERN	4B1	307, 4B6, 407, 407
DR	2D5	204, 308, 375, 307	PCLK	3D3	2D6, 307	TRE	2D5	3B4, 3B7, 2A6, 2D2
DRDY	2B7	3B7	PCLK*	3D3	3D5	TRO	2D5	4E4, 4E7
DRDY*	2B7	3B5	PCMD	304	203	TTY	4D1	4A4
DRR*	3D4	2D6	PE	2D5	3D5	TTY*	401	4A4
DSR*	406	2A5	PICK	3A7	2A6, 202			
			PEN*	301	3E5	WDROY	3B6	2B1
			PRDY	3D7	308			
EPK*	3B7	202						

JUMPERING WIRE LIST					
-1 ASSY		-2 ASSY		-3 ASSY	
FROM	TO	FROM	TO	FROM	TO
-	-	A	B	A	B
-	-	C	D	C	D
-	-	E	F	E	H
-	-	-	-	J	K
-	-	J	L	-	-
V	N	V	N	-	-
-	-	-	-	X	Y
TT	UU	TT	UU	-	-
DD	EE	DD	EE	TT	VV
CC	EE	CC	EE	UU	WW
-	-	STAC	STAN	STAC	STAN
-	-	SGA-C	SGA-NC	SGA-C	SGA-NC
-	-	-	-	SB1-C	SB1-NC
-	-	-	-	SE-3	SE-10

NOTE: UNLESS OTHERWISE SPECIFIED

① THE THREE CHARACTER SOURCE/ADDRESS IS AS FOLLOWS:
SHEET NUMBER (VERTICAL ZONE) - HORIZONTAL ZONE.

② CAPACITORS ARE 100V.
③ RESISTORS ARE 1/4W, ±5%.
④ CR1-4 ARE 704000-107 (43039).
⑤ CR5 IS 704004-006 (LED).
⑥ CR6, CR7, CR8 ARE 704203-118 (MPSA06).
⑦ CR9 IS 704320-141.
⑧ CR10 IS 704320-142.
⑨ CR11 IS 704320-43.
⑩ CR12, CR13 ARE 701900-015.
⑪ CR14, CR15 ARE 701900-007.
⑫ CR16 AND CR17 ARE 701900-014.
⑬ CR18 IS 704216-101.
⑭ CR19, CR20, CR21, CR22, CR23 ARE 704810-110 (4069).
⑮ CR24, CR25, CR26, CR27, CR28 ARE 704810-109 (40906).
⑯ CR29, CR30, CR31, CR32 ARE 704810-106 (4013).
⑰ CR33, CR34 ARE 704810-113 (4013).
⑱ CR35, CR36 ARE 704810-108, 4011.
⑲ CR37, CR38, CR39 ARE 704810-111 (4071).
⑳ CR40, CR41, CR42, CR43 ARE 704810-112 (4081).
㉑ CR44, CR45 ARE 704810-113 (4528).
㉒ CR46 IS 704810-114 (14411).
㉓ CR47, CR48 ARE 704810-109 (4068).
㉔ CR49, CR50, CR51 ARE 704810-109 (4019).
㉕ CR52 IS 704810-112 (4044).
㉖ CR53 IS 704810-113 (4070).
㉗ CR54 IS 113379-001.
㉘ CR55, CR56 ARE 704810-111 (4085).
㉙ CR57 IS 704810-115 (1M6402A).
㉚ CR58 IS 704810-114 (4082).
㉛ CR59 IS 704810-107 (4001).
㉜ CR60, CR61, CR62 IS 704810-103 (4049).
㉝ CR63, CR64 ARE 704610-175 (75189).
㉞ CR65, CR66 ARE 704610-174 (75188).
⑤ SEE WIRE LIST FOR JUMPERS.
⑥ -001 ASSY ONLY.
⑦ -001 & -002 ASSEMBLIES ONLY.
⑧ REF ASSY DWG 113771-*.
⑨ CR6 IS 704000-110 (FDH6666).

SPARES:

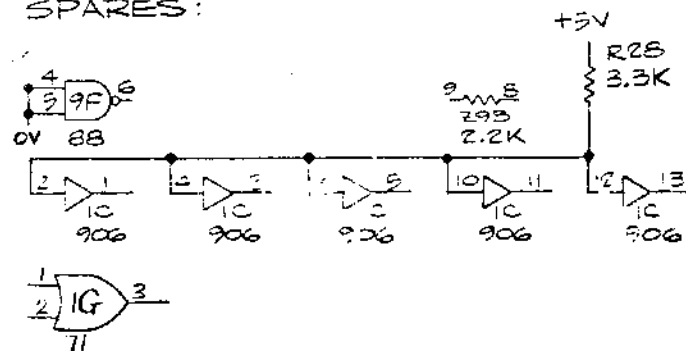

LAST DESIGNATION USED	UNUSED
CAPACITOR C48	C10-17
DIODE CR6	
INTEGRATED CIRCUIT E99	
RESISTOR R311	
TRANSISTOR Q2	

REV STATUS CONT			REVISION STATUS		
SCHEM	FAB	ASSY	SCHEM	FAB	ASSY
G	F	F	A	A	A
			B	A	B
			C	A	C
			D	A	C
			E	A	C
			F	C	D
			G	D	E
			H	E	-

MAX 22X	-
MAX 22Y	-
MAX 22Z	-

SCHEMATIC - RS232 INTERFACE CARD

REVEX 1722 ALTON STREET RIVINE, CALIF. 92714

DWG NO. 5712-001G

SHEET 05

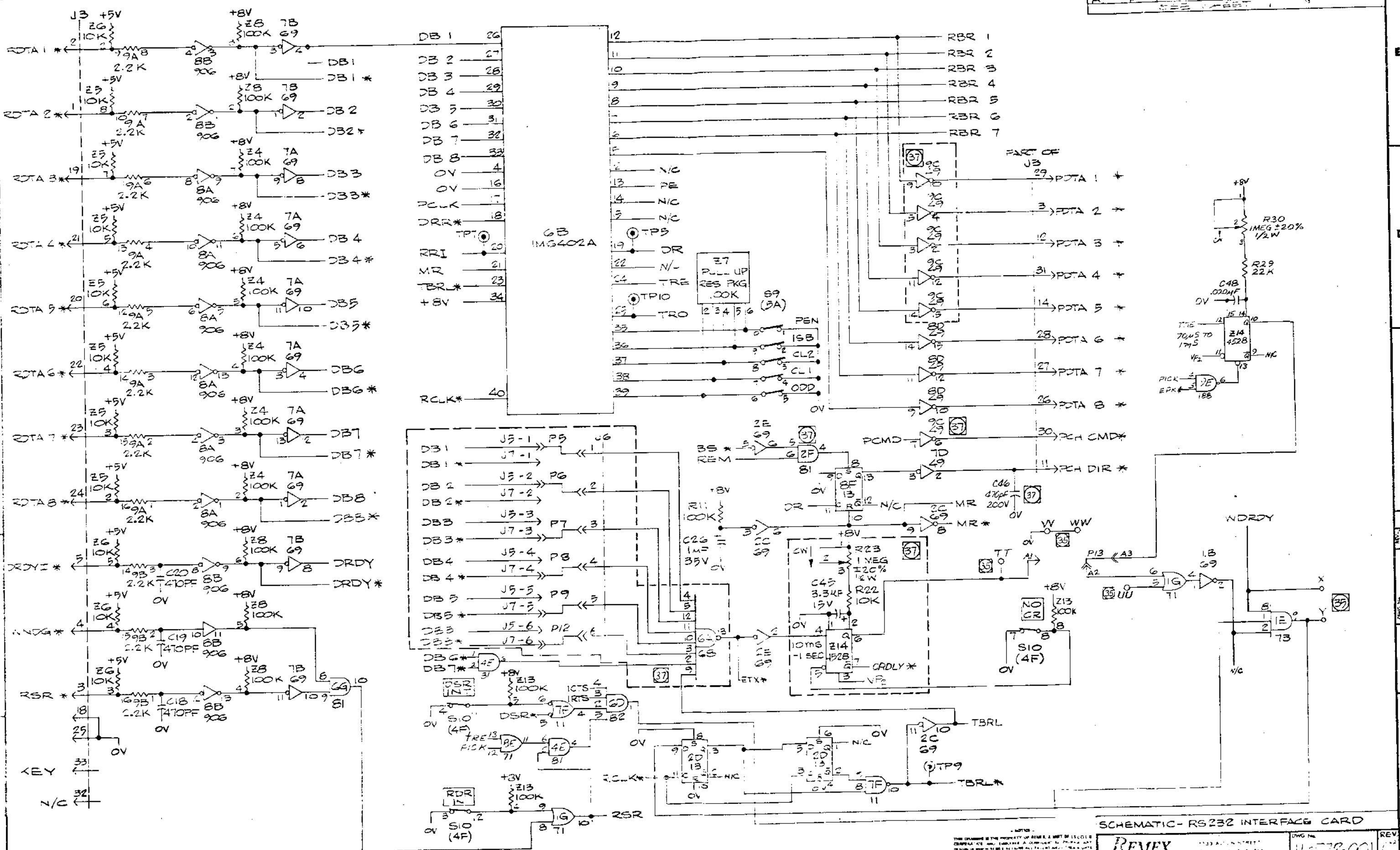

115772-001 G

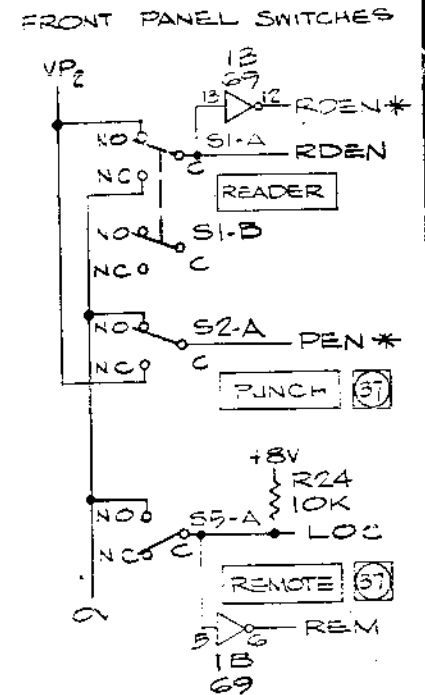
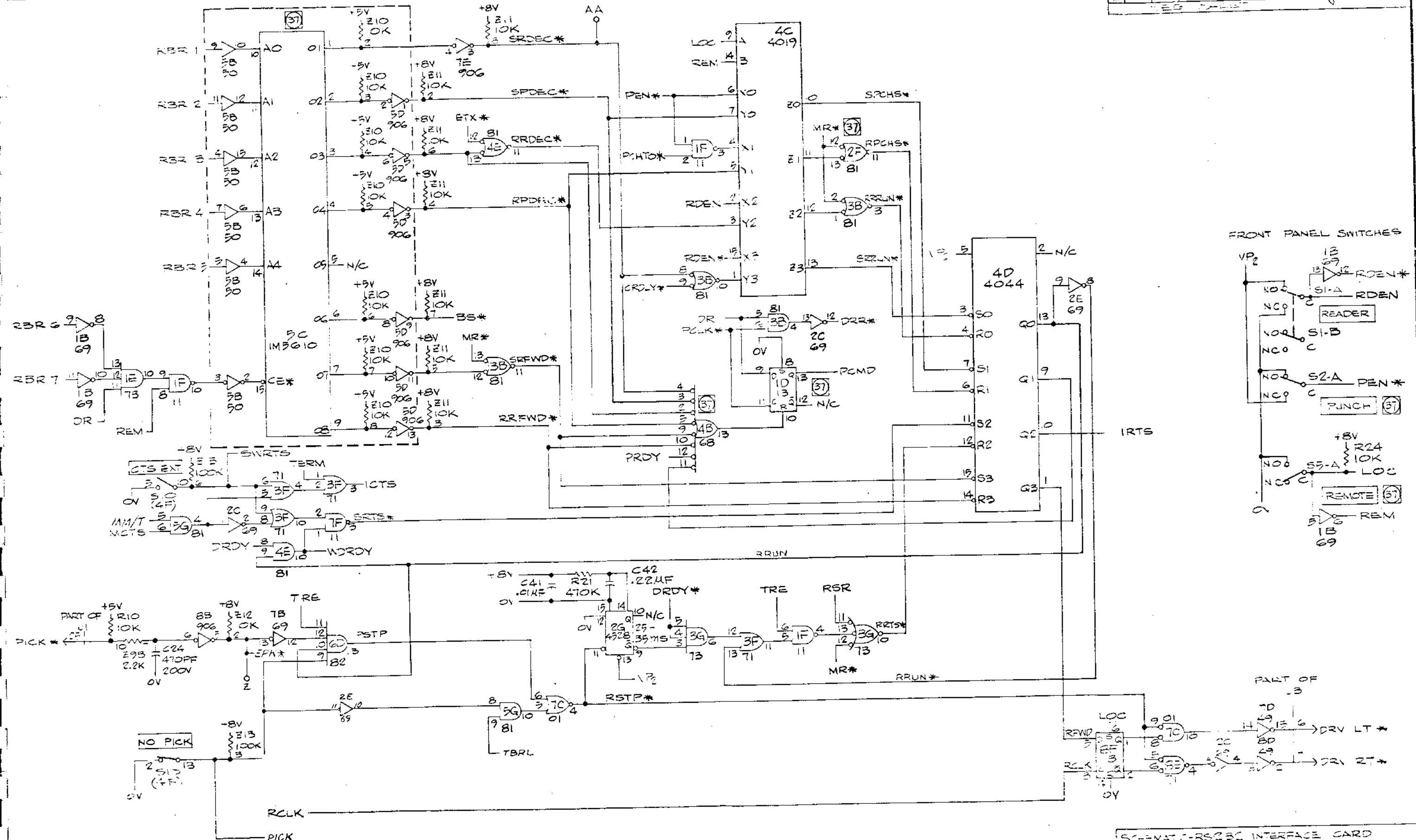

SC-5040 C-RS232C INTERFACE CARD

REMEX	1333 ALTON STREET IRVINE, CALIF. 92614	DWG No.	11377201 G	REV.	
NOTES			SHEET 3 OF 5		

11377201 G
 Dwg No.

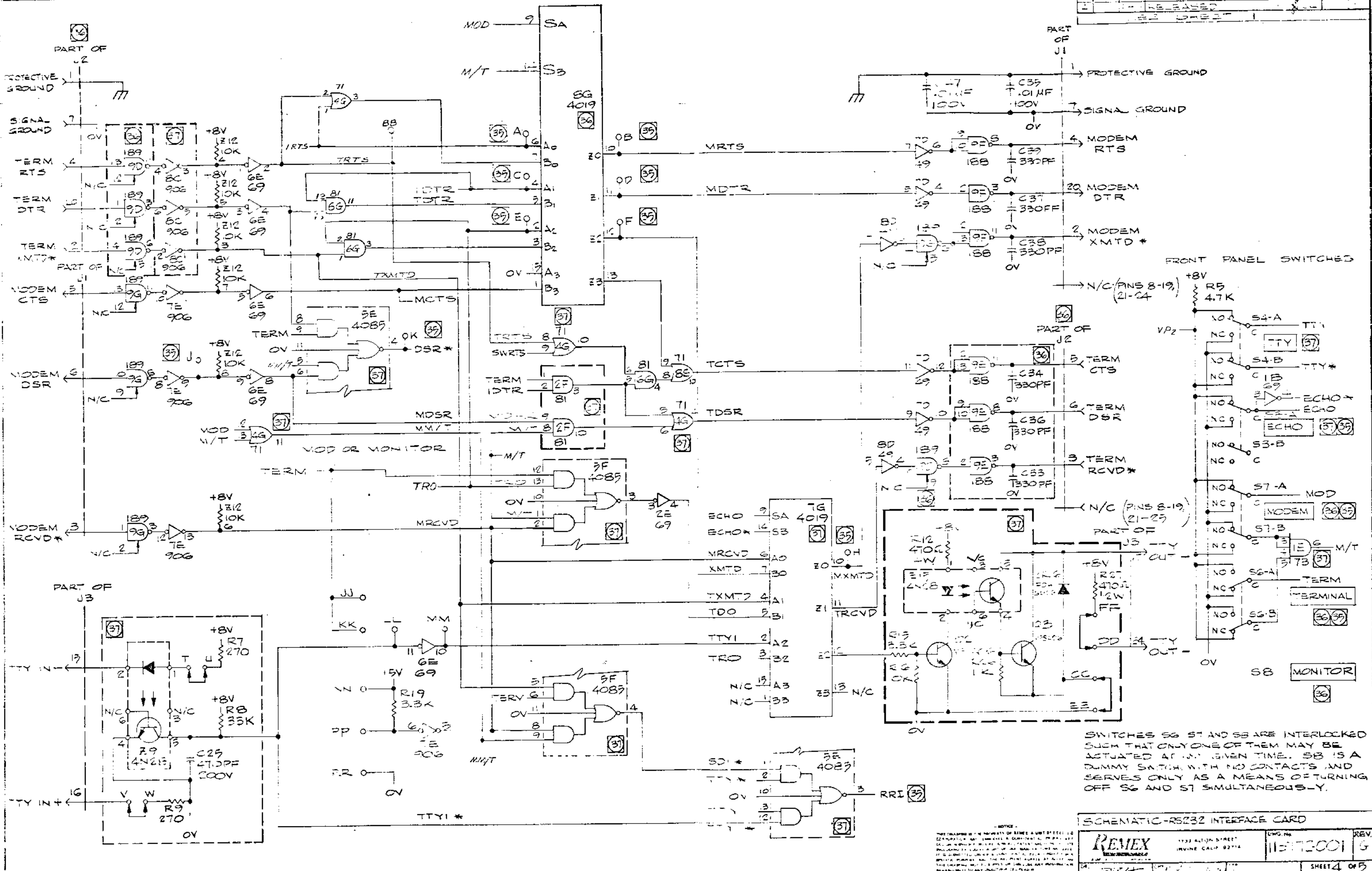

SWITCHES S6 S7 AND S8 ARE INTERLOCKED SUCH THAT ONLY ONE OF THEM MAY BE ACTUATED AT ANY GIVEN TIME. S8 IS A DUMMY SWITCH WITH NO CONTACTS AND SERVES ONLY AS A MEANS OF TURNING OFF S6 AND S7 SIMULTANEOUSLY.

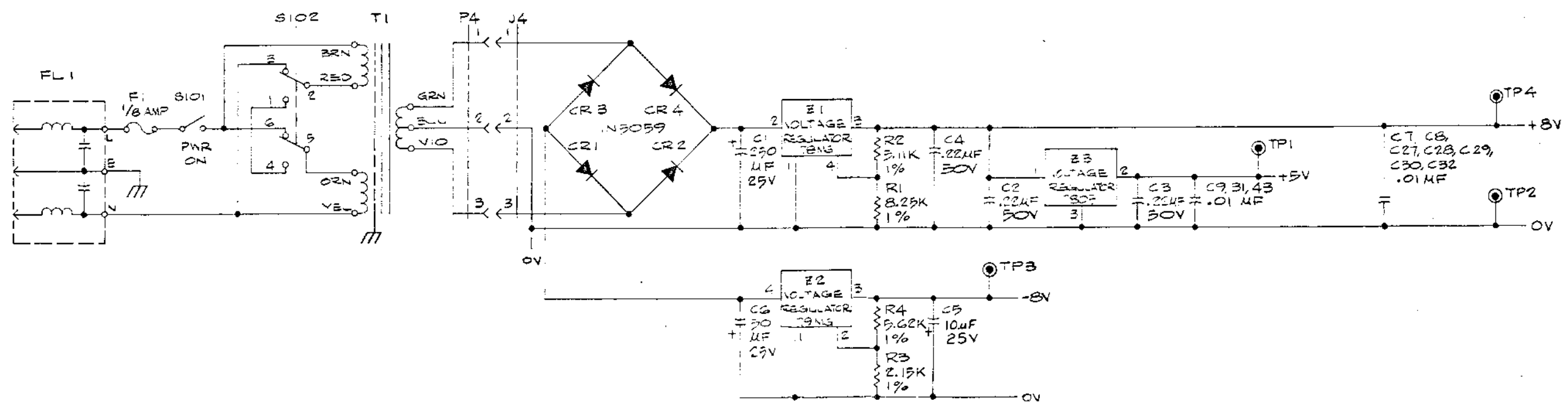
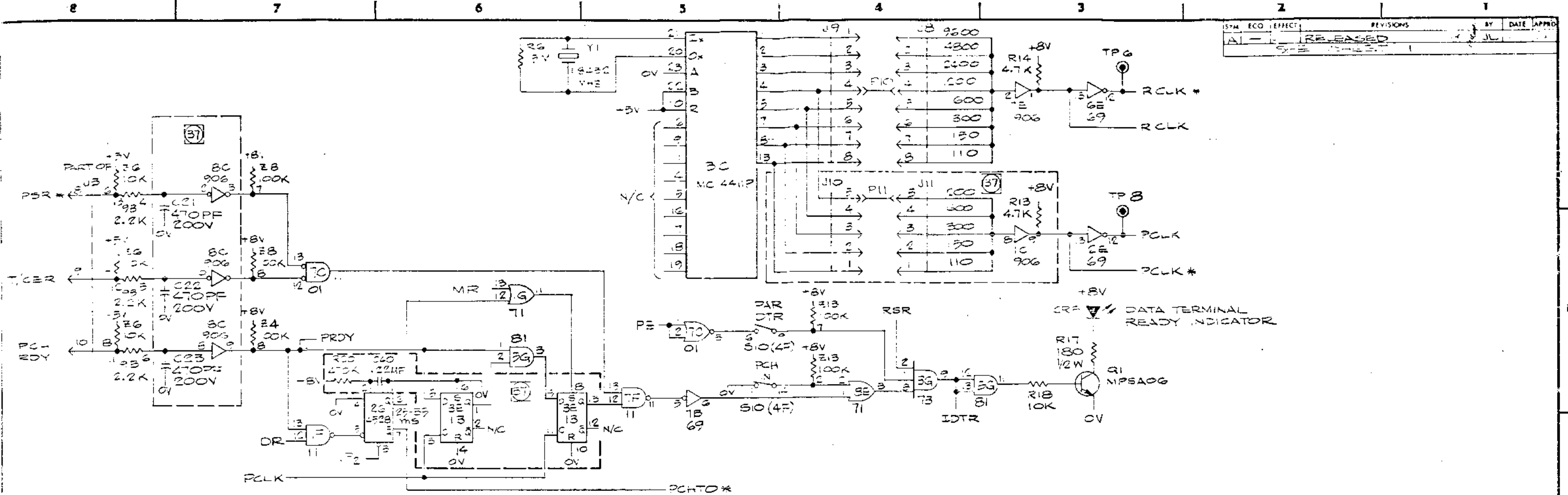

NOTICE: THE DRAWING IS THE PROPERTY OF REMEX. IT IS LOANED TO YOU FOR YOUR INFORMATION ONLY. IT IS NOT TO BE REPRODUCED OR TRANSMITTED IN ANY FORM OR BY ANY MEANS, ELECTRONIC OR MECHANICAL, INCLUDING PHOTOCOPYING, RECORDING, OR BY ANY INFORMATION STORAGE AND RETRIEVAL SYSTEM, WITHOUT THE WRITTEN PERMISSION OF REMEX. THE ENGINEER WILL BE RESPONSIBLE FOR ANY AND ALL REVISIONS TO ANY DRAWING IN THIS DRAWING.

Ex-Cell-O Corporation

REMEX DIVISION