

REMEX

A UNIT OF EX-CELL-O CORPORATION

REFER TO ADDENDUM SHEET

TECHNICAL MANUAL

TAPE READER/PERFORATOR SYSTEM

MODELS: RDB3075BC1, RAB3075BC1
RDF3075BC1, RAF3075BC1

REFER TO ADJUSTMENT SHEET
TECHNICAL MANUAL

TAPE READER/PERFORATOR SYSTEM

MODELS: RDB3075BC1, RAB3075BC1
RDF3075BC1, RAF3075BC1

SERIAL ~~3797~~ 37997

REMEX
A UNIT OF EX-CELL O CORPORATION

1733 ALTON STREET
SANTA ANA, CALIFORNIA 92705
(714) 557-6860

Copyright © 1972 by REMEX, A Unit of Ex-Cell-O Corporation. Printed in the United States of America. All rights reserved. This book or parts thereof may not be reproduced in any form without permission of the publishers.

WARRANTY

Remex warrants to the original buyer that this product is free from defects in workmanship and material under normal use and service. Unless otherwise agreed to in writing, Remex's obligation under this warranty shall be limited to furnishing a replacement for, or at Remex's option, repairing this product or any part or parts thereof which, to Remex's satisfaction, prove defective within one year (unless specifically excepted below*) from the date of shipment by Remex, provided all warranty stipulations of Remex Standard Terms and Conditions are complied with. No product or part may be returned without Remex's prior approval. In no event will any claim for labor in removing or replacing a defective product or part or for consequential damages be allowed.

NOTE:

No warranty is made as to this product or part which has not been registered, installed, operated or maintained in accordance with instructions conveyed by Remex or the instructions contained in this technical manual or which has been subject to misuse, abuse, accident or alteration or to improper or negligent use, maintenance, storage, transportation or handling.

This warranty is in lieu of all other warranties, expressed or implied, and Remex neither assumes, nor authorizes any person or firm to assume for it, any other or further obligations or liability in connection with the sale, installation or use of this product.

A Warranty Registration Card is included with each unit which must be completed and mailed within (30) days after receipt of the product.

*(Excludes lamps and fuses in all products. Excludes all punch mechanisms for labor in excess of 90 days or that have exceeded a use volume of 700 rolls (84 million characters) of Remex recommended paper tape.)

TABLE OF CONTENTS

<u>Section</u>	<u>Title</u>	<u>Page</u>
I	GENERAL DESCRIPTION.	1-1
1.1	<u>EQUIPMENT DESCRIPTION</u>	1-1
1.2	<u>EQUIPMENT SUPPLIED</u>	1-2
1.3	<u>EQUIPMENT WARRANTY</u>	1-5
1.4	<u>MAINTENANCE EQUIPMENT REQUIRED BUT NOT SUPPLIED</u>	1-5
1.5	<u>SPECIFICATIONS</u>	
1.6	<u>MODEL NUMBER DESIGNATION</u>	1-7
1.7	<u>PHYSICAL DESCRIPTION</u>	1-10
1.8	<u>TAPE CHANNEL NUMBERING</u>	1-10
1.9	<u>TAPE PREPARATION SPECIFICATIONS</u>	1-12
II	INSTALLATION	2-1
2.1	<u>UNPACKING</u>	2-1
2.2	<u>SYSTEM MOUNTING</u>	2-1
2.3	<u>INITIAL ADJUSTMENTS</u>	2-1
2.4	<u>POWER AND SYSTEM CONNECTIONS</u>	2-2
2.4.1	TRANSFORMER WIRE CHANGES FOR DIFFERENT AC SUPPLY VOLTAGES	2-2
2.5	<u>INTERFACE CIRCUITRY</u>	2-4
III	OPERATION.	3-1
3.1	<u>INPUT-OUTPUT SIGNALS</u>	3-1
3.2	<u>CONTROL FUNCTIONS</u>	3-1
3.3	<u>OPERATING INSTRUCTIONS, PERFORATOR</u>	
3.3.1	TAPE LOADING AND THREADING, PERFORATOR	3-1
3.3.2	TAPE FEED/DELETE MODE.	3-5
3.3.3	ASYNCHRONOUS FORWARD MODE.	3-6
3.3.4	ASYNCHRONOUS REVERSE MODE.	3-6
3.4	<u>OPERATING INSTRUCTIONS, READER</u>	3-8
3.4.1	TAPE LOADING AND THREADING, READER	3-8
3.4.2	TAPE DRIVE, ASYNCHRONOUS OPERATION, EXTERNAL INPUT	3-9

TABLE OF CONTENTS (Continued)

<u>Section</u>	<u>Title</u>	<u>Page</u>
3.4.3	TAPE DRIVE, HIGH SPEED OPERATION	3-9
3.4.4	ASYNCHRONOUS OPERATION, FRONT PANEL SWITCHES	3-11
3.5	<u>OPERATING INSTRUCTIONS, DUPLICATOR (RDB and RDE Units)</u>	3-11
3.6	<u>TAPE RECOMMENDATIONS</u>	3-11
3.7	<u>OPERATIONAL MAINTENANCE</u>	3-11
3.7.1	CHAD DETECTOR RESET.	3-13
3.8	<u>TAPE PREPARATION REQUIREMENTS</u>	3-13
IV	THEORY OF OPERATION	
4.1	<u>BLOCK DIAGRAM DESCRIPTION</u>	4-1
4.1.1	TAPE PERFORATION CONTROL	4-1
4.1.2	READER DRIVE CONTROL	4-2
4.1.3	TAPE READING	4-6
4.1.4	MANUAL SPOOLER OPERATION	4-6
4.1.5	DUPLICATION MODE OPERATION	4-6
4.2	<u>CIRCUIT DESCRIPTIONS</u>	4-9
4.2.1	CONTROL LOGIC AND FEED HOLE DRIVER CARD 110261	4-9
4.2.1.1	<u>Punch Command Control</u>	4-9
4.2.1.2	<u>FEED Switch Operation</u>	4-10
4.2.1.3	<u>DELETE Switch Operation</u>	4-11
4.2.1.4	<u>System Ready Signal Description</u>	4-11
4.2.1.5	<u>Tape Handling Signal Description</u>	4-11
4.2.1.6	<u>Chad Error Signal Description</u>	4-12
4.2.1.7	<u>Tape Low Signal Description</u>	4-12
4.2.2	DATA LOGIC CARD 110251	4-12
4.2.3	STEP MOTOR POWER SUPPLY CARD, 109061-2	4-13
4.2.4	STEP MOTOR DRIVER CARD 109891.	4-17
4.2.4.1	<u>Motor Control Circuit Description, Asynchronous Modes</u>	4-17
4.2.4.2	<u>Synthetic Feed Hole and Data Circuitry</u>	4-23

TABLE OF CONTENTS (Continued)

<u>Section</u>	<u>Title</u>	<u>Page</u>
4.2.4.3	<u>High Speed Mode Operation</u>	4-24
4.2.4.4	<u>Power Turn-On and Load</u>	4-25
4.2.5	READER MOTOR AMP CARD, 110011.	4-25
4.2.6	CHAD DETECTOR CARD 110291-1	
4.3	<u>RPM1075 PUNCH MECHANISM</u>	4-25
4.4	<u>LIGHT SOURCE</u>	4-26
4.5	<u>HYBRID READ HEAD ASSEMBLY</u>	4-26
V	MAINTENANCE.	5-1
5.1	<u>GENERAL</u>	5-1
5.2	<u>PREVENTIVE MAINTENANCE, PERFORATOR SECTION</u>	5-1
5.2.1	50 ROLL SERVICE.	5-2
5.2.1.1	<u>Functional Check</u>	5-2
5.2.2	500 ROLL SERVICE	5-4
5.2.2.1	<u>Supply Platter Brake Wear (RAB and RDB Units Only)</u>	5-4
5.2.2.2	<u>Bearing Checks (RAB and RDB Units Only)</u>	5-4
5.2.2.3	<u>Control Logic</u>	5-4
5.2.2.4	<u>Power Supply Voltages (Perforator Section)</u>	5-5
5.2.2.5	<u>Supply Deck Checks (RAB and RDB Units Only)</u>	5-5
5.2.2.5.1	Tape Tension Arm	5-5
5.2.2.5.2	Tape Low Switch Actuation.	5-5
5.2.2.5.3	Supply Brake	5-6
5.2.2.5.4	Supply Error Switch, S7.	5-6
5.2.3	2000 ROLL SERVICE.	5-6
5.2.3.1	<u>Parts Check</u>	5-6
5.2.3.2	<u>Moveable Parts</u>	5-6
5.3	<u>PREVENTIVE MAINTENANCE, READER SECTION</u>	5-6
5.3.1	CLEANING	5-7
5.3.1.1	<u>Read Head Assembly Cleaning</u>	5-9
5.3.1.2	<u>Lamp and Lens Cleaning</u>	5-9

TABLE OF CONTENTS (Continued)

<u>Section</u>	<u>Title</u>	<u>Page</u>
5.3.1.3	Sprocket Cleaning.	5-9
5.3.1.4	<u>Tape Cleaning</u>	5-10
5.3.1.5	<u>General Cleaning</u>	5-10
5.3.2	LUBRICATION.	5-10
5.3.3	POWER SUPPLY VOLTAGES, READER SECTION.	5-10
5.4	<u>TROUBLE SHOOTING</u>	5-11
5.5	<u>ADJUSTMENTS, PERFORATOR SECTION.</u>	5-20
5.5.1	GENERAL.	5-20
5.5.2	CONTROL LOGIC TIMING ADJUSTMENTS	5-20
5.5.3	+5V POWER SUPPLY	5-21
5.5.4	RUN-LOAD SWITCH.	5-21
5.5.5.	SUPPLY DECK ADJUSTMENTS (RDB and RAB UNITS ONLY)	5-22
5.5.5.1	<u>Tape Tension Arm Adjustment (RDB and RAB Units Only)</u>	5-22
5.5.5.2	<u>Tape Low Switch Actuator (RDB and RAB Units Only)</u>	5-22
5.5.5.3	<u>Brake Linkage (RDB and RAB Units Only)</u>	5-22
5.5.5.4	<u>Supply Error Switch, S7 (RDB and RAB Units Only)</u>	5-24
5.6	<u>READER ADJUSTMENT PROCEDURES</u>	5-25
5.6.1	GENERAL.	5-25
5.6.2	READER DRIVE SYSTEM AND LAMP ALIGNMENT	5-25
5.6.3	+5.40 LAMP VOLTAGE ADJUSTMENT.	5-28
5.6.4	ANTI-JITTER CONTROL ADJUSTMENT	5-28
5.6.5	READER SPEED ADJUSTMENT.	5-31
5.6.6	TAPE SPLICING.	5-31
VI	PARTS REPLACEMENT.	6-1
6.1	<u>GENERAL</u>	6-1
6.2	<u>PUNCH REMOVAL (RDB AND RAB UNITS ONLY)</u>	6-1
6.3	<u>PUNCH REMOVAL (RDF AND RAF UNITS ONLY)</u>	6-1
6.4	<u>FRONT PANEL - CHASSIS SEPARATION (RDB AND RAB UNITS ONLY)</u>	6-2

TABLE OF CONTENTS (Continued)

<u>Section</u>	<u>Title</u>	<u>Page</u>
6.5	<u>FRONT PANEL - CHASSIS SEPARATION (RDF AND RAF UNITS ONLY)</u>	6-4
6.6	<u>CARD REMOVAL</u>	6-4
6.7	<u>LOW TAPE ARM - BRAKE BLOCK DISASSEMBLY (RAB AND RDB UNITS ONLY)</u>	6-4
6.8	<u>SUPPLY ARM REPLACEMENT (RDB AND RAB UNITS ONLY)</u>	6-6
6.9	<u>UPPER COVER, READER</u>	6-6
6.10	<u>READ HEAD ASSEMBLY REPLACEMENT</u>	6-6
6.11	<u>LIGHT SOURCE ASSEMBLY REPLACEMENT</u>	6-8
6.12	<u>SPROCKET WHEEL OR STEP MOTOR ASSEMBLY REPLACEMENT</u>	6-9
6.13	<u>TRANSFORMER REPLACEMENT</u>	6-9
VII	PARTS LIST	
7.1	<u>GENERAL</u>	7-1
7.2	<u>KIT OF PARTS</u>	7-2
7.3	<u>RECOMMENDED SPARE PARTS</u>	7-2
7.3.1	RECOMMENDED SPARE PARTS, MODELS RAB3075 AND RDB3075	7-2
7.3.2	RECOMMENDED SPARE PARTS, MODELS RAF3075 AND RDF3075	7-3
7.4	<u>PARTS LIST, RAB3075 AND RDB3075</u>	7-4
7.5	<u>PARTS LIST RAF3075 AND RDF3075</u>	7-17
7.6	<u>PARTS LIST, OPTIONS</u>	7-27
VIII	DRAWINGS	8-1/8-2
8.1	<u>GENERAL</u>	8-1/8-2

LIST OF ILLUSTRATIONS

<u>Figure</u>	<u>Title</u>	<u>Page</u>
1-1	REMEX Punched Tape Reader/Perforator System, Model RDB3075BC1	1-3
1-2	REMEX Punched Tape Reader/Perforator System, Model RAF3075BC1	1-4
1-3	Installation Drawing, Model RAB3075 and RDB3075.	1-8
1-4	Installation Drawing, Model RAF3075 and RDF3075.	1-9
1-5	REMEX Model Number Code.	1-11
1-6	Tape Channel Numbering and Dimensions.	1-12
2-1	Reader/Perforator System Connections to External Equipment.	2-3
2-2	Recommended Interface Circuitry.	2-4
2-3	Chassis Slide Installation	2-5/2-6
3-1	Timing Diagram, Perforator Section	3-7
3-2	Timing Diagram, Tape Reader Section.	3-10
4-1	Block Diagram, Punch Control Section	4-3
4-2	Block Diagram, Step Motor Driver Card 109891-6X0	4-4
4-3	Waveforms and Timing Diagram, Perforator Section	4-7/4-8
4-4	Timing Diagram, Motor Control Circuit, Asynchronous Operation.	4-15/4-16
4-5	Synthetic Feedhole Timing Diagram, Step Motor Driver Card 109891.	4-19/4-20
4-6	Motor Control Circuit Timing Diagram, High Speed Operation, Step Motor Driver Card 109891	4-21/4-22
5-1	Location of Circuit Card Potentiometers and Test Points.	5-21
5-2	Supply Deck Adjustments.	5-23
5-3	Reader Drive System and Lamp Alignment	5-26
5-4	Setting of the Lower and Upper Tape Guides in Relation to the Sprocket	5-27
5-5	FH Cell Test Pin Output During the Adjustment of the Anti-Jitter Control Circuitry.	5-29
5-6	Tape Splicing Procedure.	5-33
6-1	Punch and Chassis Mounting Screw Locations, RDB and RAB Units Only	6-3
6-2	Punch and Chassis Mounting Screw Locations, RAF and RDF Units Only	6-5
6-3	Exploded View of Low Tape Arm - Brake Block Assembly	6-7
7-1	Exploded View of Read Head Assembly.	7-8
7-2	RDB3075BCX, Top View.	7-11
7-3	RDB3075BCX, Top View of Deck Assembly with Hub Assembly.	7-12
7-4	RDB3075BCX, Front View of Front Panel.	7-13

LIST OF ILLUSTRATIONS

<u>Figure</u>	<u>Title</u>	<u>Page</u>
7-5	RDB3075BCX, Rear View of Front Panel.	7-14
7-6	RDB3075BCX, Rear View	7-15
7-7	RDB3075BCX, Bottom View	7-16
7-8	RAF3075BCX, Top View.	7-22
7-9	RAF3075BCX, Front View of Front Panel	7-23
7-10	RAF3075BCX, Rear View of Front Panel.	7-24
7-11	RAF3075BCX, Rear View	7-25
7-12	RAF3075BCX, Bottom View	7-26
7-13	Control Logic and Feed Hole Driver Card 110261-60 Assembly.	7-29
7-14	Data Logic and Driver Card 110251-6 Assembly.	7-31
7-15	Step Motor Power Supply Card 109061-2 Assembly.	7-33
7-16	Step Motor Driver Card 109891-660 Assembly.	7-36
7-17	Optional Chad Detector Card 110291-1 Assembly	7-38
8-1	Schematic, RAB3075BC1	8-3/8-4
8-2	Schematic, RDB3075BC1	8-5/8-6
8-3	Schematic, RAF3075BC1	8-7/8-8
8-4	Schematic, RDF3075BC1	8-9/8-10
8-5	Schematic, Control Logic and Feed Hole Driver Card 110261	8-11/8-12
8-6	Schematic, Data Logic and Driver Card 110251.	8-13/8-14
8-7	Schematic, Power Supply 109061-2.	8-15/8-16
8-8	Schematic, Step Motor Driver 109891	8-17/8-18
8-9	Schematic, Reader Motor Amplifier Card 110011-1	8-19/8-20
8-10	Schematic, Chad Detector Card 110271, Option.	8-21/8-22
8-11	Feed Hole Test Pin Circuitry, Reader Sensor	8-23
8-12	IC Assembly Modules Used on the Circuit Cards	8-24
8-13	IC Modules Used on the Circuit Card	8-25
8-14	IC Modules Used on the Circuit Card	8-26
8-15	IC Modules Used on the Circuit Card	8-27
8-16	REMEX Standard Schematic Symbols.	8-28
8-16	REMEX Standard Schematic Symbols.	8-29/8-30

LIST OF TABLES

<u>Table</u>	<u>Title</u>	<u>Page</u>
1-1	Equipment Supplied	1-2
1-2	Specifications for the RAB3075, RAF3075, RDB3075 and RDF3075.	1-5
3-1	Interface Signal Descriptions.	3-2/3-3
3-2	Front Panel Controls	3-4
3-3	Acceptable Tapes	3-12
5-1	Maintenance Equipment Required	5-1
5-2	Preventive Maintenance Schedule and Log, Perforator Section.	5-3
5-3	Preventive Maintenance Schedule and Log, Reader Section.	5-8
5-4	Trouble Shooting Chart	5-12
7-2	Data Logic Card 110251-X Assembly.	7-30
7-3	Step Motor Power Supply Card 109061-2 Assembly	7-32
7-4	Step Motor Driver Card 109891-6X1 Assembly	7-34
7-5	Optional Chad Detector Card 110291-1 Assembly.	7-37

SECTION I
GENERAL DESCRIPTION

1.1 EQUIPMENT DESCRIPTION

This manual has been prepared to assist the user in operating, installing and maintaining the following REMEX reader/perforator combinations: RAB3075BC1 (Figure 1-1) RAF3075BC1 (Figure 1-2) RDB3075BC1 and RDF3075BC1. All units punch tape at 75 characters/second and read tape at up to 300 characters/second. In addition, the RDB and RDF3075 systems have the ability to duplicate the tape being read by the reader. The RDB3075 appears the same as the RAB3075 and the RDF3075 appears the same as the RAF3075 except for a switch change.

A complete description of the model number is given in Section 1.6 and the specifications are listed in Table 1-2. Material covered in this manual is applicable to all models except as specifically noted. The operation and maintenance of the punch mechanism itself is described in a separate manual.

Incorporating its highly successful tape punch, Model RPM1075, these perforator/reader combinations provide a selection for most applications where punched tape is used. Tape is supplied from a standard 1000 foot roll or a box of 1000 feet of fanfolded tape mounted on a deck assembly above the chassis and threaded through the perforator. Punching is controlled by means of input signals which are processed and used to operate the punch at speeds up to 75 characters/second. The roll type punched tape is fed through an opening in the front panel where it is available for customer take-up. Fanfolded tape, after it is punched, is folded into a bin on the front panel.

The function of the reader is to convert the information stored in the form of punched holes into electronic signals. A plug-in circuit board provides the logic control for tape movement in either direction from external signals or the front panel switches. The outputs from the card control a step motor which drives the tape via a sprocket wheel. Data outputs are generated from the hybrid photocell read head which contains both the photocells and output amplifiers. As tape passes over the photocells, changes in light intensity are sensed by the photocells, amplified, and brought out to an

external connector. Operation of the reader is independent of the punch so that they can both be operated at the same time if required.

Several options are available as listed in Table 1-2 including positive (mode 5) or negative (mode 6) logic and selectable AC power input.

1.2 EQUIPMENT SUPPLIED

Various items have been included with the tape reader/perforator system for spare parts, installation, and maintenance. These items are listed in Table 1-1.

Table 1-1. Equipment Supplied

<u>Item</u>	<u>REMEX Part No.</u>	<u>Quantity</u>
Brush	716003-101	1
Connector, P1, Cannon DB-25P	706500-231	1
Connector, 15 pin, modified, P3	109143	1
Contacts (P3)	706530-133	15(RAB) 20(RAF)
Cover, Connector (P1)	706540-136	1
Fuse (100, 115, or 127 VAC operation) 2.5 amp, Slow-Blow, F1	705710-124	1
Fuse (220, 230, or 240 VAC operation) 1.5 amp, Slow-Blow, F1	705710-138	1
Fuse, Punch Mechanism, 2.0 amp	716072-184	3
Grease, Rocol, 1 oz tube	716004-169	1
Lubrication Instructions Punch	110275	1
Instruction Sheet, Chassis Slide Mounting	110304	1
Manual	-	1
Nipple, Grease (for punch lubrication)	716072-201	1
Power Cord, 10 feet (P2)	708000-020	1
Screw, 10-32 x 5/16 long (RAB and RDB Units Only)	709931-805	4
Screw, 10-32 x 3/4 long (RAF Units Only)	709931-812	4
Screw Lock Assembly, Male (P1)	706540-124	2
Striker Plate Assembly, Left (RAB and RDB Units Only)	109475-1	1
Striker Plate Assembly, Right (RAB and RDB Units Only)	109475-2	1
Striker Plate Assembly, Left (RAF and RDF Units Only)	109925-1	1
Striker Plate Assembly, Right (RAF and RDF Units Only)	109925-2	1
Tape, Roll (RAB and RDB Units Only)	715200-002	1
Tape, Fanfold (RAF and RDF Units Only)	715200-001	1
Washer, Lock, No. 10	713541-306	4

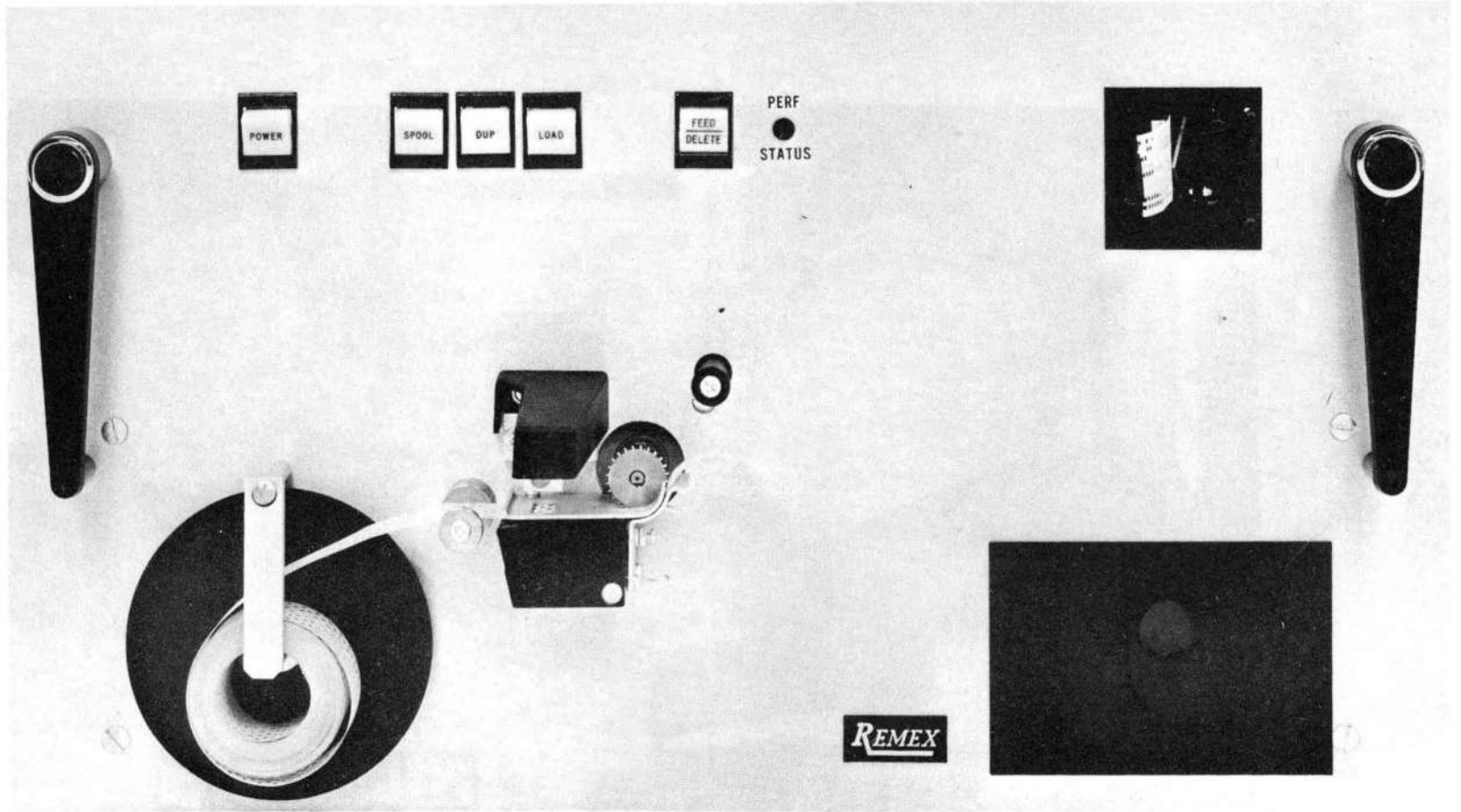

Figure 1-1. REMEX Punched Tape Reader/Perforator System, Model RDB3075BC1. The FAB3075 is identical except for two switch function changes.

1.3 EQUIPMENT WARRANTY

A statement covering the warranty of this equipment is given on page iii (second page in book). It should be read and understood. All preventive maintenance procedures must be performed as outlined in Section 5.2 during the warranty period in order that the warranty remain in effect. Any questions arising concerning the warranty should be directed to the REMEX Service Department.

1.4 MAINTENANCE EQUIPMENT REQUIRED BUT NOT SUPPLIED

The maintenance procedures in Section 5 require equipment that is not supplied. This equipment is listed in Table 5-1.

1.5 SPECIFICATIONS

Listed in Table 1-2 are the characteristics and specifications of the REMEX tape reader/perforator combinations. Also see Section 1.6 for complete model number description and Figure 1-5 which indicates how the options are incorporated into the model structure. An X in a particular digit designator denotes any of the combinations given in Figure 1-5 (for that designator) can be used. Model designations using X's are frequently used throughout the manual, especially the parts list. Refer to Table 3-1 for signal descriptions.

Table 1-2. Specifications for the RAB3075, RAF3075, RDB3075 and RDF3075.

Characteristics	Perforator	Reader
Tape Material and Dimensions	Perforates standard 5, 6, 7 and 8 track unoled (preferred) or oiled paper tapes as well as most Mylar-paper-Mylar and Mylar-foil-Mylar laminate tapes with a thickness between 0.003 and 0.0043 inch.	Reads tape of any material with thickness between 0.0027" and 0.0045" whose transmissivity does not exceed 57% (oiled buff paper tape). Tape must be prepared to ANSI X3.18 or ECMA 10 standards for base material and perforations. Reads 1", 8-channel tapes. Special tape options available.
Tape Loading	Threading	In-Line
Tape Form	1,000 foot roll (2 inch core) (RAB or RDB) or fanfolded (RAF or RDF)	Loop, Strip, or Fanfolded (RAF or RDF Only).

Table 1-2. Specifications for the RAB3075, RAF3075,
RDB3075 and RDF3075 (Continued)

Characteristics	Perforator	Reader
Tape Direction	Bidirectional with backspacing limited to 10 rows (1" max.)	Bidirectional (left-to-right or right-to-left)
Speed	Up to 75 characters per second asynchronously.	Asynchronously, up to 200 characters per second. High speed at 300 characters/sec. min. See operational modes.
Timing	Timing Diagram shown in Figure 3-1.	Timing Diagram shown in Figure 3-2.
Life Expectancies	Minimum punch life expectancy is 8.4×10^7 characters when used with oiled or unoled paper tape.	Reader lamp has been derated approximately 15% to provide a life expectancy in excess of 13,000 hours.
Operational Modes	<p><u>Tape Feed/Delete:</u> Under control of front panel switch unit will feed tape forward at approximately 75 cps while punching sprocket holes only in FEED or all holes in DELETE.</p> <p><u>Asynchronous Forward:</u> Tape moves forward one row and is punched at a rate up to 75 cps. See Section 3.3.3.</p> <p><u>Asynchronous Reverse:</u> Tape moves in reverse direction without punching data or sprocket holes. See Section 3.3.4.</p>	<p><u>Asynchronous Operation:</u> Reader drives tape at up to 200 characters/sec. min., with pulse or continuous drive signal. See Section 3.4.2.</p> <p><u>High Speed Operation:</u> Reader drives tape at 300 cps, min. with pulse or continuous drive signal. See Section 3.4.3.</p>
Input-Output Control Signals	See Table 3-1, Interface Signal Descriptions.	See Table 3-1, Interface Signal Descriptions.
The following specifications apply to the entire reader/perforator systems.		
Input Power	100, 115, or 127 VAC, 47 to 64 Hz, single-phase, 2.2 amps; 220 or 240 VAC, 47 to 64 Hz, single phase, 1.1 amps.	
Environmental	<p>Temperature: Operating: +5°C to +55°C (free air).</p> <p>Humidity: Operating: 10% to 90% relative humidity without condensation.</p> <p>Non-Operating: All conditions without condensation of either water or frost.</p>	

Table 1-2. Specifications for the RAB3075, RAF3075, RDB3075 and RDF3075 (Concluded)

Characteristics	Perforator	Reader
Dimensions	See Installation Drawing, Figures 1-3 and 1-4.	
Weight	RAF or RAB3075: 42 lbs	
Options	<ol style="list-style-type: none"> 1. Positive (Mode 5) or negative (Mode 6) logic on Punch Command and Punch Data input lines. All RDF3075 and RDB3075 units must be mode 5. 2. Positive (Mode 5) or negative (Mode 6) logic on Punch Ready and Tape Handling Error output lines. All RDF3075 and RDB3075 units must be mode 6. 3. Tape Handling Error being true will not inhibit Punch Ready Output or Punch Command input. 4. 100, 115, 127, 220 or 240 VAC, 47-64 Hz power input (customer wirable). 5. Positive (Mode 5) or negative (Mode 6) logic on Reader Outputs. All RDF3075 and RDB3075 units must be mode 5. 6. One of the following chassis slide assemblies is available (not coded as part of the model number). <ul style="list-style-type: none"> 109600-1: Two 12-inch long slides with 13-inch travel and two slide mounting plates. 109601-1: Two 22-inch long slides with 23-inch travel and two slide mounting plates. 109602-1: Two 22-inch long slides with 23-inch travel, four slide mounting brackets and two slide mounting plates. 110305-1: Two 12-inch long slides with 13-inch travel, four slide mounting brackets and two slide mounting plates. 110345-1: Two 22-inch long x 3/8" wide slides with mounting brackets and plates. 7. Chad Detector Option which inhibits punch when chad reaches a predetermined level (not coded as part of model number). 8. Desk Top Enclosure (not coded as part of model number). 	

1.6

MODEL NUMBER DESIGNATION

The REMEX model designation is used to code the basic functions, options, and configurations of a particular product line. Figure 1-5 illustrates the model code structure for the RAB/RDB/RAF/RDF3075 series and indicates the various options. An X in a particular digit designator (as used in many parts of this manual, especially the parts list) denotes any of the combinations given in Figure 1-5 can be used.

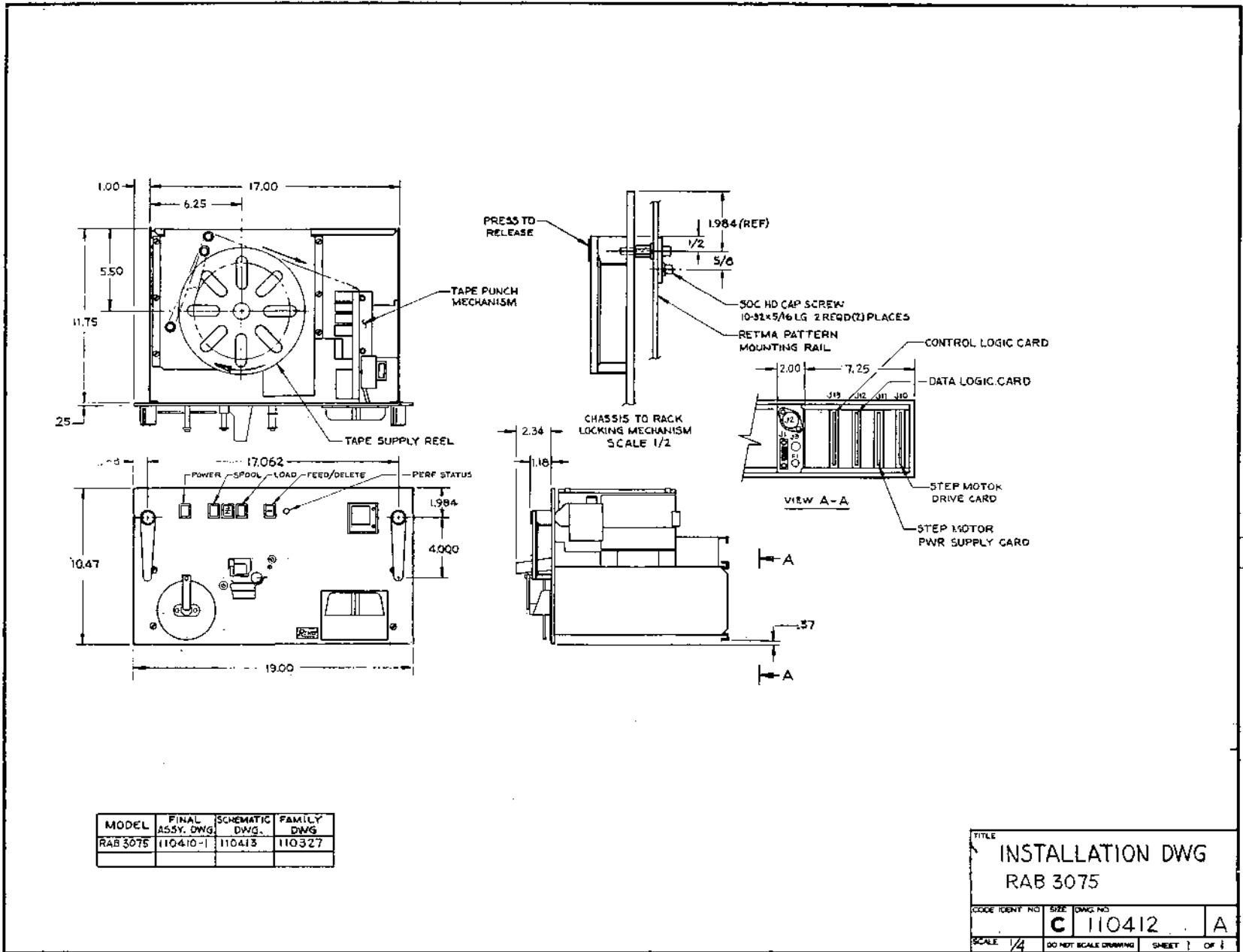

FORM No. ED 603/011

110412 A

Figure 1-3. Installation Drawing, Model RAB3075 and RDB3075

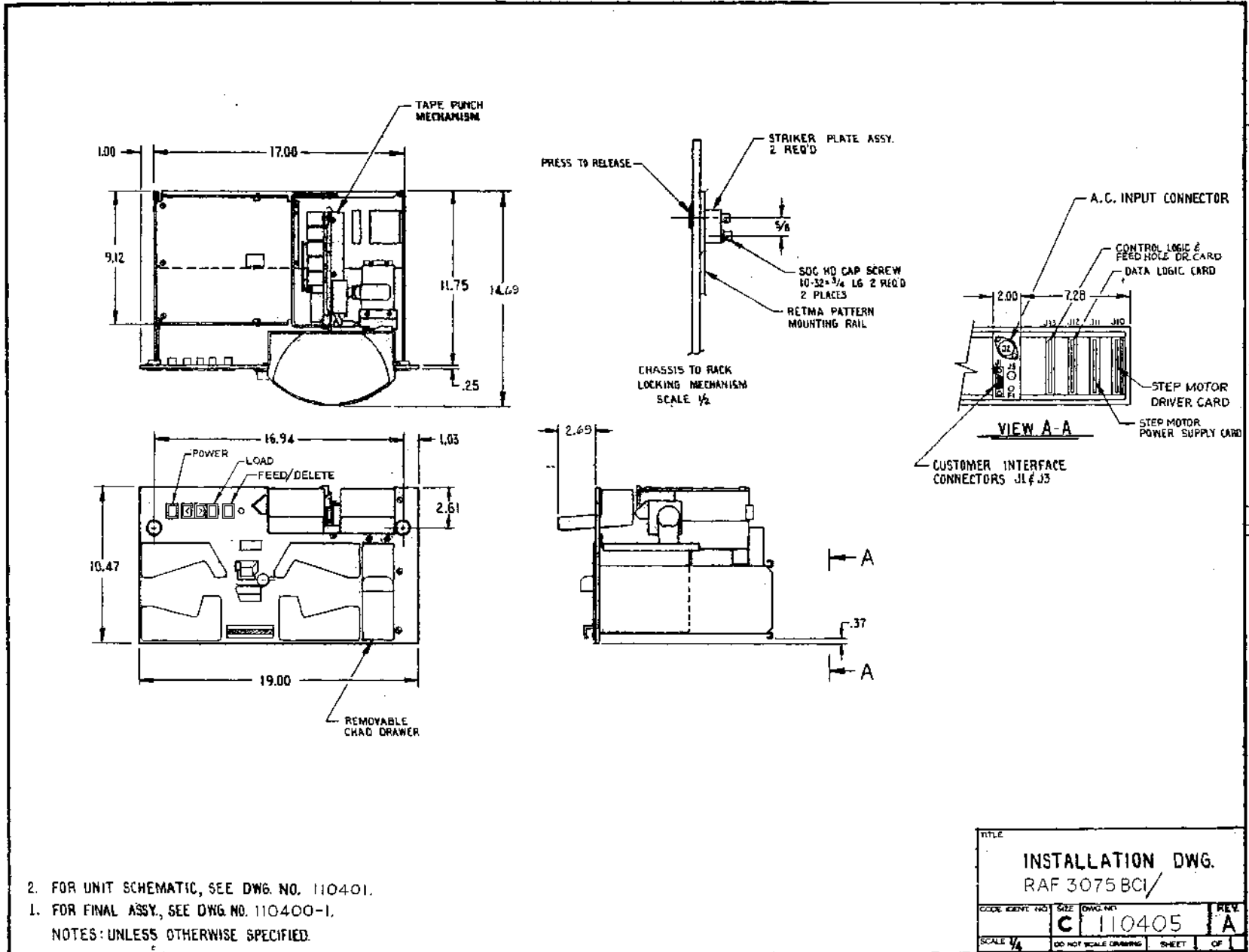

2. FOR UNIT SCHEMATIC, SEE DWG. NO. 110401.

1. FOR FINAL ASSY, SEE DWG. NO. 110400-1.

NOTES: UNLESS OTHERWISE SPECIFIED.

TITLE			
INSTALLATION DWG.			
RAF 3075 BCI/			
CODE IDENT. NO.	SIZE	DWG. NO.	REV.
	C	110405	A
SCALE 1/4	DO NOT SCALE DRAWING		SHEET OF

FORM No. ED 603/011

Figure 1-4. Installation Drawing, Model RAF3075 and RDF3075

Nonstandard (special) units use the last three numbers of the model number to denote a special unit. The difference between any special unit and the standard unit is described in an addendum at the end of the manual. Units with 000 and 901 and higher are standards and are covered in this manual without addendums.

Standard options not shown in Figure 1-5 are used in the 901 and higher numbers (standard units only) and are listed on the serial tag below the model number in the form of a series of three digit numbers depending upon the number of options used. For example, a unit with 902 in the last three digits of the model number would list two three digit numbers. Because the list of possible options is constantly changing, it is not included in the manual. Generally, this list consists of special customer requirements that do not affect the operation of the unit and includes such things as special paint, no logo, mill edge panel, etc.

Always consult the serial number tag for proper voltage and frequency to be used and for model identification. Failure to do so could result in damage to the unit. The serial tag is located on one of the rear surfaces. In all correspondence, always refer to the complete model number including the mode, the last three numbers, and the unit's serial number. Refer to the CAUTION in Section 2.4.

1.7 PHYSICAL DESCRIPTION

The REMEX tape reader/perforator combination is mounted on a 19-inch panel with a height of 10-1/2 inches. Detailed dimensions are shown in Figures 1-3 and 1-4. The electronic chassis and supply deck is mounted at the rear of the unit and contains the circuit cards. The front panel contains the tape reading and transport mechanism and fanfold tanks (RAF and RDF models) which extend 2.48 inches out from the front panel. Chassis slides are also provided to give easy access to the supply deck and punch mechanism.

1.8 TAPE CHANNEL NUMBERING

REMEX tape reader/perforator combinations are available to punch tape of the configurations shown in Figure 1-6. The type of tape guide used in any given unit is coded in the tenth digit as part of the model number. See Figure 1-5. Note that regardless of the width of the tape or the number of tracks, the numbering of the track holes is always the same. Also see Section 1.9.

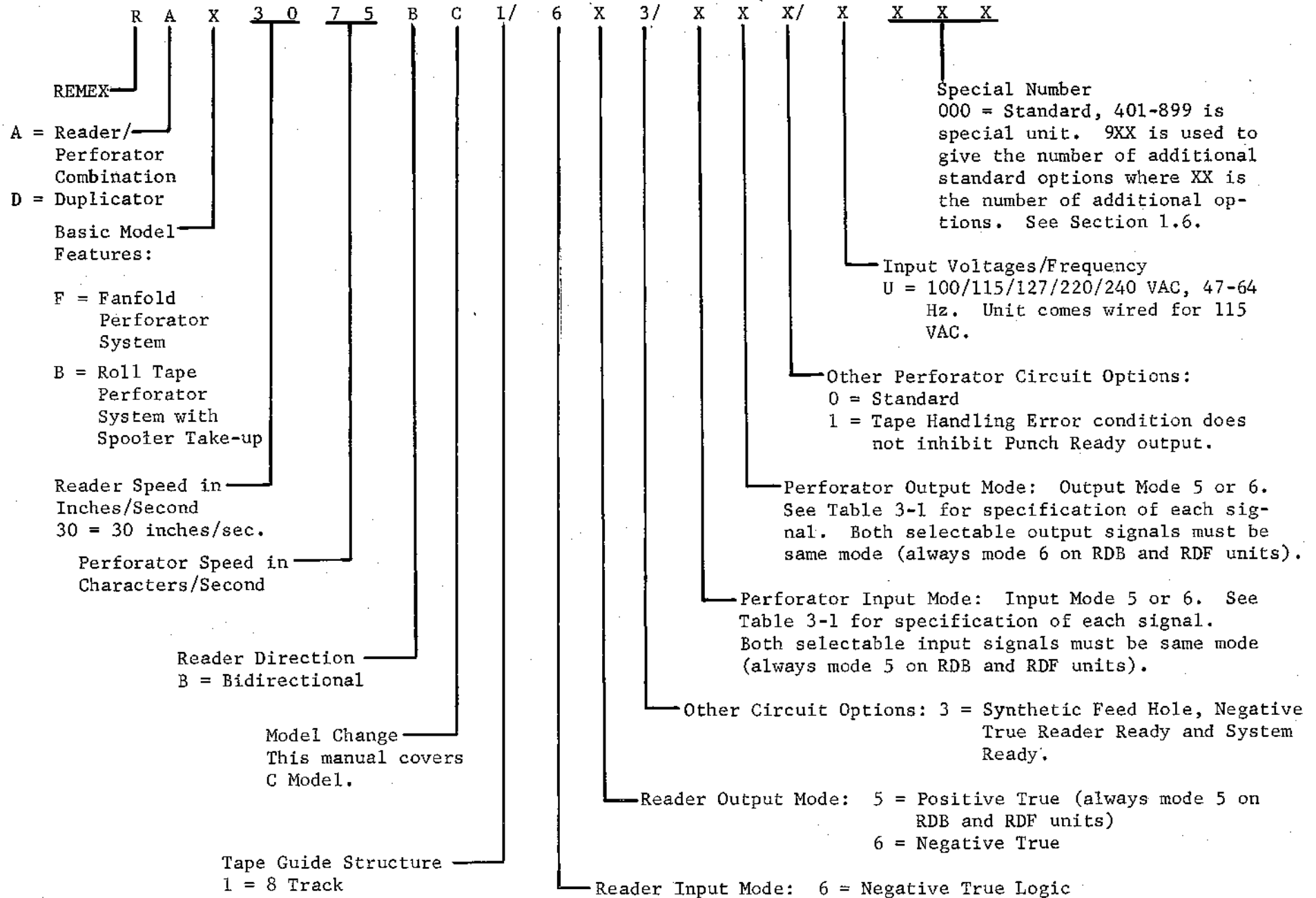
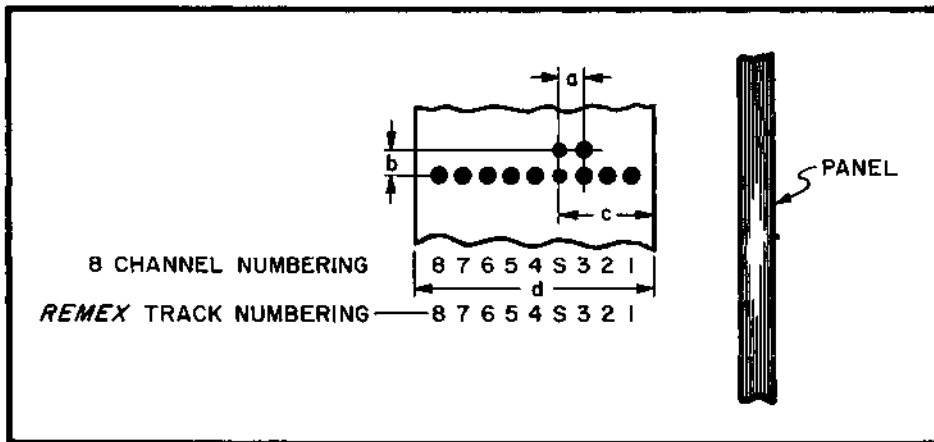

Figure 1-5. REMEX Model Number Code

Tape specifications as given in Figure 1-6, are based on the American National Standards Institute Standard X3.18-1967 (ANSI; formerly United States of America Standards Institute). A tape gauge is included at the rear of the RPM1075 manual so that longitudinal and perpendicular transverse spacings can be checked. To use the gauge, place the feed hole of one end of a 5-inch span in the arc until one of the cross hairs is centered in the feed hole. Read the measurement adjacent to that cross hair (plus tolerances to the right and minus tolerances to the left). A second 5-inch gauge is printed at the bottom to check longitudinal and perpendicular transverse center line spacing.



MMC 285

$$a = 0.100 \pm 0.002$$

In span of 1 inch feed hole center lines are ± 0.010 .

In span of 5 inches feed hole center lines are ± 0.025 .

$$b = 0.100 \pm 0.003$$

$$c = 0.392 \pm 0.004$$

$$d = 1.000 \pm 0.003$$

$$\text{Data Hole Diameter} = 0.072 \pm .002$$

$$\text{Sprocket Hole Diameter} = 0.046 \begin{matrix} +.002 \\ -.001 \end{matrix}$$

Tolerances on location of code holes in any one transverse row, relative to the center line of the feed hole in that row, shall be ± 0.003 inch in the longitudinal direction.

Figure 1-6. Tape Channel Numbering and Dimensions.

SECTION II

INSTALLATION

2.1 UNPACKING

Specially designed, reinforced packing cartons have been used in the shipment of the tape reader/perforator system to provide the best possible protection during transit. Also packed with the unit in separate plastic bags and packages is the kit of parts listed in Table 1-1. A careful visual inspection of the unit should be made as soon as it is removed from the carton for any apparent damage incurred during shipping. In the event the unit has been damaged as a result of shipping, the carrier and REMEX should be notified as soon as possible. When carrying or removing the unit from the carton, it is important that it be lifted by the handles, front panel, or chassis. Never attempt to lift it by the covers, tape tanks, chassis slides or other parts which may not support the weight of the unit.

2.2 SYSTEM MOUNTING

The unit contains chassis slides which mount to the cabinet wall. See Figure 1-3 or 1-4. The mounting dimensions of all slide options are the same. In addition, the front panel of the rear unit secures to the cabinet by means of two mounting studs which snap into sockets at the rear of the two handles. RAF and RDF units also use two mounting studs but they snap into sockets of two release push buttons. The studs are part of two striker plates which are mounted on each side of the rack by two screws each. To release the sockets from the studs, depress the button at the top of the handle. Figures 1-3 and 1-4 illustrate the mounting of the striker plates and chassis slide mounting hole pattern. Mounting should be in such a manner that adequate cooling is provided. The ambient temperature should not exceed the value listed in Table 1-2. Figure 2-3 illustrates the installation of the slides.

2.3 INITIAL ADJUSTMENTS

Each unit has been accurately adjusted and aligned before leaving the factory. No adjustments or calibrations are required prior to installation or use.

A.C. power is applied to the unit through a standard three-prong receptacle, J2, located at the rear of the unit.

CAUTION

All units come wired for 115 VAC, 47-64 Hz operation. If another voltage is to be used, a wire change on the transformer must be made as described in Section 2.4.1. In addition, before operating the system, the proper fuse value (as indicated in Table 1-1) must be inserted from the kit of parts. Discard the other fuse (unless, of course, a different voltage operation is anticipated).

Refer to the serial tag for proper operating modes of the unit. See Section 1.6 and Figure 1-5 for an explanation of the model number and operating modes.

All control signals and output signals are routed through J1 for the perforator and J3 for the reader which are also located at the rear of the unit. Figure 2-1 lists the signals associated with each pin and their description is given in Table 3-1. All wire sizes are 22 AWG unless noted in Figure 2-1. The proper mating connectors for J1-J3 have been supplied with the unit. The insert contacts for P3 can either be crimped (using an Amp crimping tool) or soldered to the customer cable. To disconnect P3 and J3 (or any other plastic connector) it is necessary to press in on the two guide interlocks on each side of the receptacle that fit into the plug.

2.4.1 TRANSFORMER WIRE CHANGES FOR DIFFERENT AC SUPPLY VOLTAGES

Units are supplied with a transformer which allows any of five input voltages to be used: 100, 115, 127, 220 or 240 VAC, 47-64 Hz. Unless otherwise directed by the customer, all units are wired for 115 VAC.

If it becomes necessary to use one of the other four voltages, a simple wire change is required. See schematic for appropriate unit, Figures 8-1 through 8-4. Power from the a.c. plug J2 (hi-line) is routed through J8/P8, pin 2, S1, and J8/P8, pin 1 to T1. It is necessary, then, to change the wire coming from J8, pin 1 at terminal 3 (115 VAC) on T1 to terminal 2 for 100 VAC, to terminal 5 for 127 VAC, to terminal 6 for 220 VAC or to terminal 7 for 240 VAC. The hi-line connecting the fan from J5, pin 6, must remain tied to terminal 4 on T1.

J1			
	1	_____	Data Track 1 Input
	2	_____	Data Track 2 Input
	3	_____	Data Track 3 Input
	4	_____	Data Track 4 Input
	5	_____	Data Track 5 Input
	6	_____	Data Track 6 Input
	7	_____	Data Track 7 Input
	8	_____	Data Track 8 Input
	10	_____	Direction Input
	11	_____	Punch Command Input
	12	_____	Punch Ready Output
	13	_____	Punch System Ready Output
	① 14	_____	\overline{DR} , Drive Right, Dup. Output
	① 15	_____	Punch/Command/Reader Ready Dup Input
	16,17	20 AWG	Chassis Ground
	① 18	_____	Punch Ready Dup. Output
	20	_____	Tape/Chad Error Output
	21	_____	Tape Low Output
	25	20 AWG	Signal Ground, 0V
	J2	_____	AC Power
	J3		
	1	_____	Data Track 1 Output
	2	_____	Data Track 2 Output
	3	_____	Data Track 3 Output
	4	_____	Data Track 4 Output
	5	_____	Data Track 5 Output
	6	_____	Data Track 6 Output
	7	_____	Data Track 7 Output
	8	_____	Data Track 8 Output
	9	_____	Sprocket Track Output
	10	20 AWG	Signal Ground, 0V
	11	_____	\overline{DL} , Drive Left Input
	12	_____	\overline{DR} , Drive Right Input
	13	_____	Reader System Ready Output
	14	_____	High Speed Input
	15	_____	Reader-Ready Output

Perforator
Operation -
To External
Equipment

Reader
Operation -
To External
Equipment

① Used only with RDB and RDF units when operating in Duplicate mode.

Figure 2-1. Reader/Perforator System Connections to External Equipment.
See Table 3-1 for signal descriptions.

INTERFACE CIRCUITRY

Figure 2-2 illustrates suggested drive and output circuitry with which to interface with the REMEX circuitry as referenced in Table 3-1. Note the termination network for the output signals. This should be incorporated in the external equipment for maximum noise immunity. See Figures 3-1 and 3-2 for proper timing.

NOTE

All input and output logic signals are defined for positive logic, i.e., logic 0 = 0V and logic 1 = +5V. Therefore, signals that are only 0V true (mode 6 only) for logic 1 (action condition) are written with a bar over the designation, e.g., Reader Ready Output.

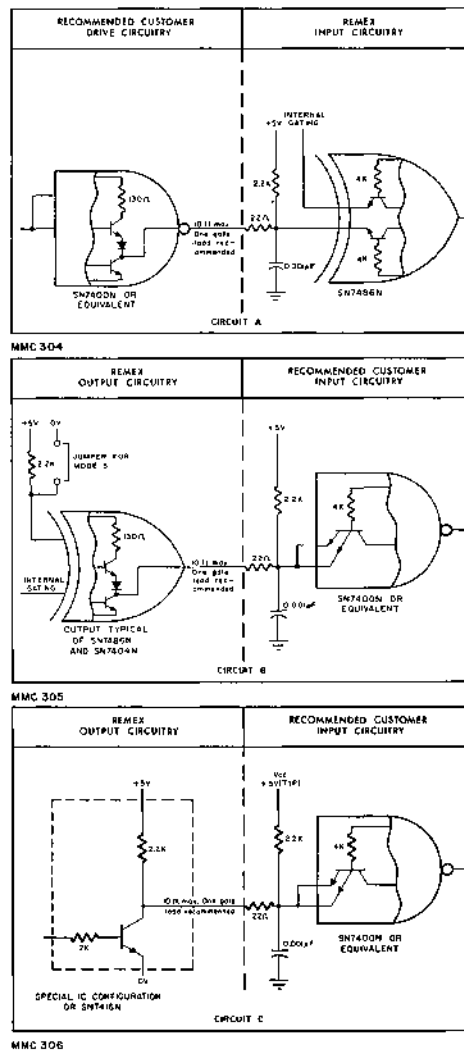
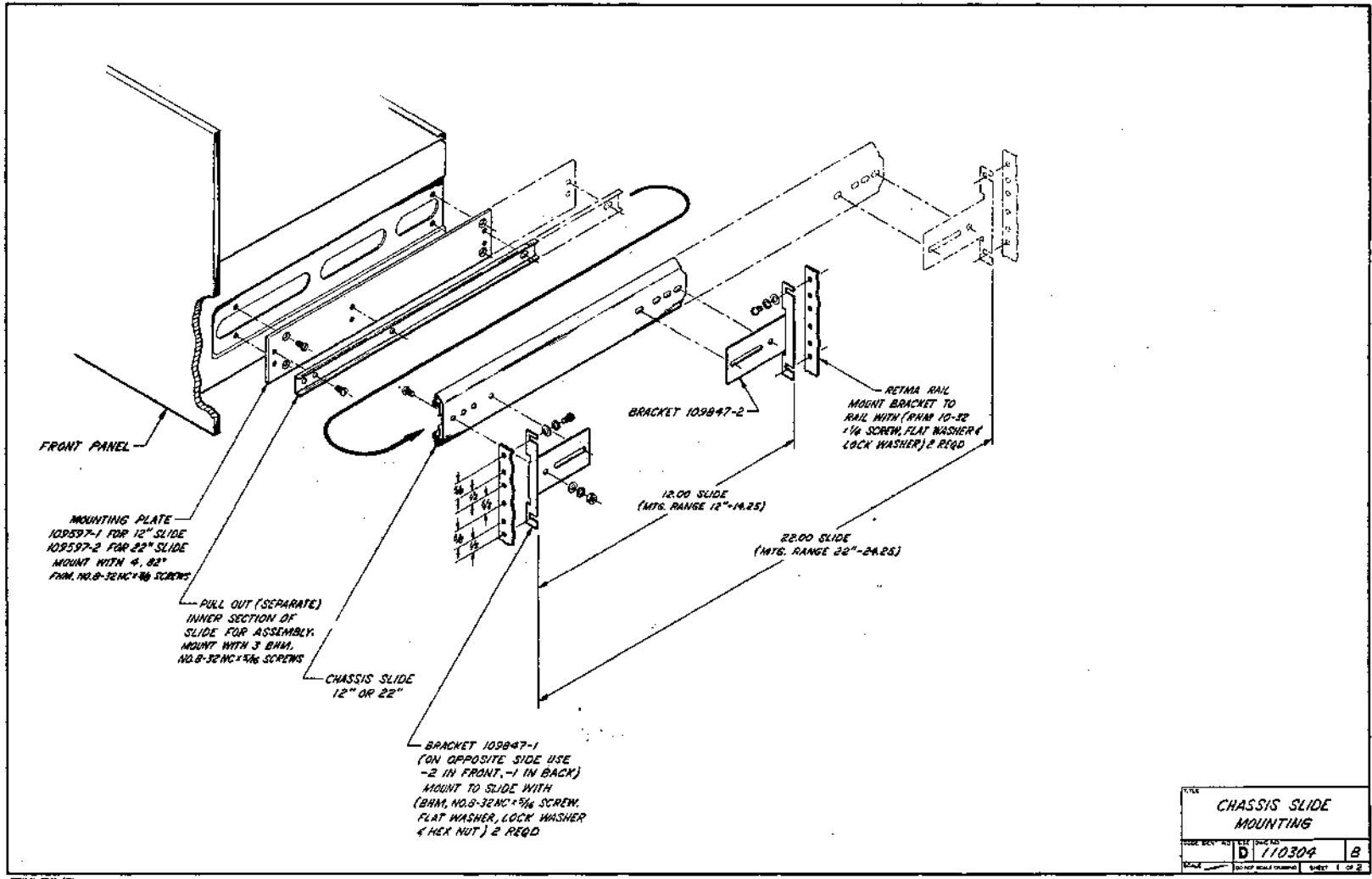

Figure 2-2. Recommended Interface Circuitry.



B 402011

Figure 2-3. Chassis Slide Installation, Sheet 1 of 2

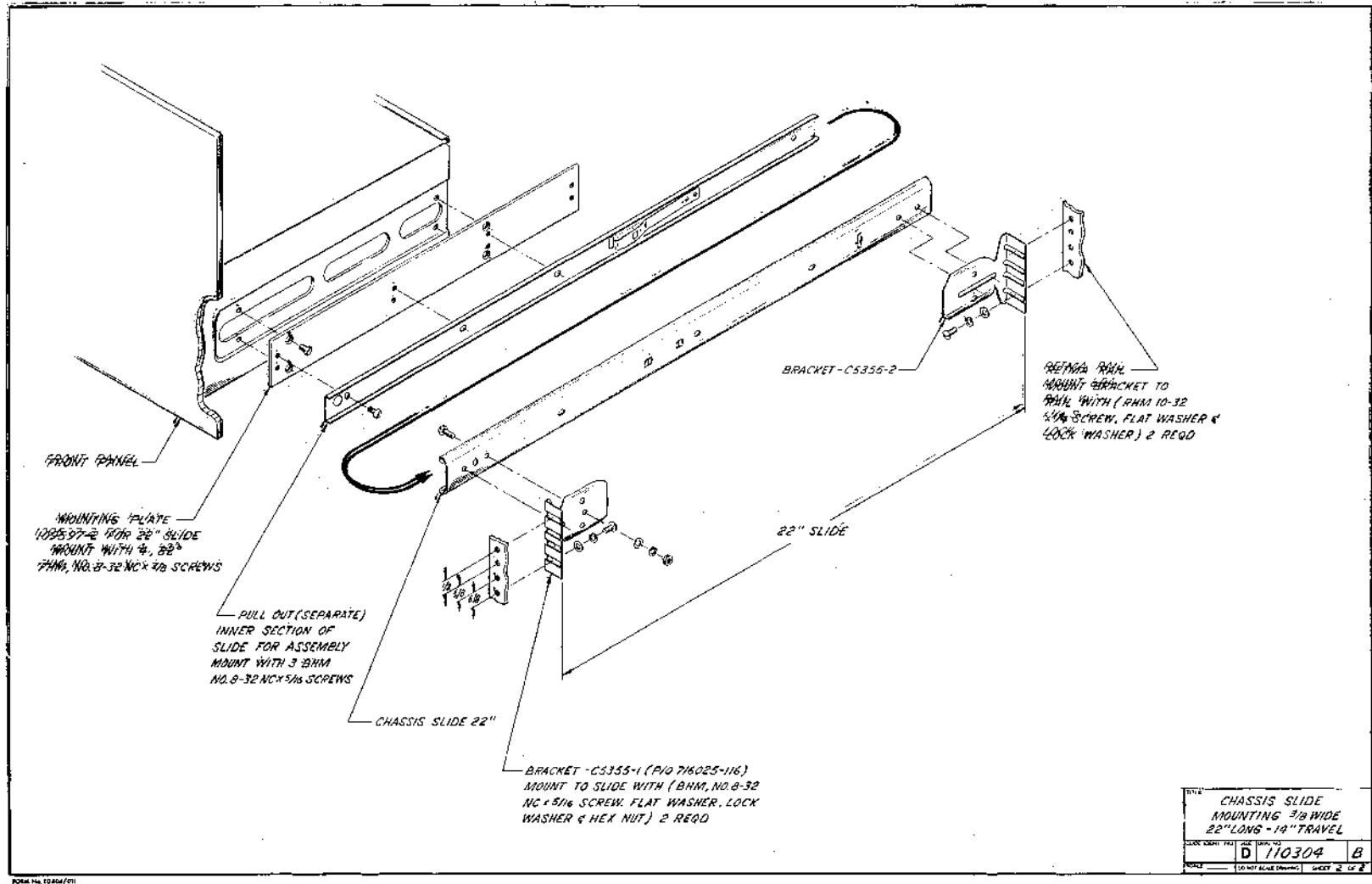

Figure 2-3. Chassis Slide Installation, Sheet 2 of 2

SECTION III

OPERATION

3.1 INPUT-OUTPUT SIGNALS

Table 3-1 lists the input and output signals which are routed through J1, J2, and J3. The definition and/or usage of these signals are also included in the table. Figure 3-1 shows timing diagrams for the perforator and Figure 3-2 shows the timing diagram for the reader. Also see Note, Section 2.5.

3.2 CONTROL FUNCTIONS

Table 3-2 lists the operating controls located on the front panel along with their descriptions and functions.

3.3 OPERATING INSTRUCTIONS, PERFORATOR

The following procedures should be followed when operating the perforator portion of the system. Refer to Figures 1-1 or 1-2 for location of switches. The reader and perforator portions operate independently, so either the reader, perforator, or both can be operated at the same time.

3.3.1 TAPE LOADING AND THREADING, PERFORATOR

Tape is supplied from the tape deck located at the top of the unit and above the chassis and is threaded through the punch mechanism. The following procedure is recommended when loading tape:

- a. Place the POWER switch in its on (lighted) position.
- b. Place the perforator RUN-LOAD switch in the LOAD position. This is accomplished by moving the RUN-LOAD lever to the left until it engages the step.
- c. RAB or RDB Units: Place a spool of tape on the supply reel and thread it through the punch and out the opening in the front panel. The threading path is shown in Figure 7-2, and on a decal mounted adjacent to the punch. RAF or RDF Units: Place a box of fanfolded tape on the supply deck and thread it through the punch and out the opening in the front panel. See Figure 7-8.

CAUTION

When pulling the perforator-reader combination system out from the cabinet on its chassis slides, do not pull beyond its mechanical stops. Doing so could remove the units from its slides resulting in the unit dropping to the floor.

Table 3-1. Interface Signal Descriptions

Connector Pin	Description	Interface Circuit (Figure 2-2)	① Positive Logic/Mode 5 Levels		① Negative Logic/Mode 6 Levels	
			False Cond. Logic 0 Level	True Cond. Logic 1 Level	False Cond. Logic 0 Level	True Cond. Logic 1 Level
PERFORATOR OPERATION						
J1-1 thru J1-8	Tracks 1-8 Data Input. True condition causes a hole to be punched for that track when a true punch command is given. Data must be present at the time a punch command is initiated and must remain on the line for 2 usec. (min.) after the punch command input reaches the true level.	A	0 < V < +0.4 @ 4.2 mA max. (ext. sink) No Hole	+2.4 < V < +5 or open circ. Hole	+2.4 < V < +5 or open circ. No Hole	0 < V < +0.4 @ 4.2 mA max. (ext. sink) Hole
J1-10	Direction Input. True condition moves tape forward and false condition moves tape in reverse as described in Operating Specifications, Modes of Operation, Table 1-2.	A	0 < V < +0.4 @ 9.0 mA max. (ext. sink) Reverse Tape Movement	+2.4 < V < +5 or open circ. Forward Tape Movement	NOT SELECTABLE IN MODE 5 ONLY	- OPERATES ONLY
J1-11	Punch Command Input. A true condition moves tape and initiates punching at up to 75 char/sec. as described in Operating Specifications, Modes of Operation, Table 1-2. This input line is disabled under the following conditions: 1) Punch Ready output is false, 2) Tape/Chad Error output is true if so optioned, 3) Chad drawer is full if so optioned. (See figure 1-5)	A	0 < V < +0.4 @ 4.2 mA max. (ext. sink) Tape Stopped	+2.4 < V < +5 or open circ. (transition) Tape Advances one row and punches.	+2.4 < V < +5 or open circ. Tape Stopped	0 < V < +0.4 @ 4.2 mA max. (transition; ext. sink) Tape Advances one row and punches.
J1-12	Punch Ready Output. True condition indicates unit is ready to accept a punch command. Output is false under the following conditions: 1) During advance and punch cycle (approx. 13 msec. following a punch command), 2) Whenever Tape/Chad Error output (J1-20) is true if so optioned, 3) When chad drawer is full if so optioned.	B	0 < V < +0.4 @ TTL fan-out of 10 Perforator Not Ready	+2.4 < V < +5 @ TTL fan-out of 10 Perforator Ready	+2.4 < V < +5 @ TTL fan-out of 10 Perforator Not Ready	0 < V < +0.4 @ TTL fan-out of 10 Perforator Ready
J1-13	System Ready Output. True condition indicates internal voltages have stabilized after power turn-on. False condition indicates power is off or internal voltages have not stabilized.	B	NOT SELECTABLE - OPERATES IN MODE 6 ONLY		+2.4 < V < +5 or open circ. TTL fan-out of 9. Perf. System Not Ready	0 < V < +0.4 @ TTL fan-out of 10. Perf. System Ready
J1-16,17	Chassis Ground. Output connection to chassis (isolated from signal ground).					
J1-20	Tape/Chad Error Output. True condition indicates one or more of the following conditions: (a) Perforator RUN-LOAD switch in LOAD or (b) Tape from supply is loose, broken or tight. In perforator system mode XX0 (see Figure 1-5) a true signal disables Punch Command input (J1-11); does not inhibit in mode XX1. On units with the Chad Detector option this signal will be true when the chad level reaches a predetermined height and will inhibit punching (all modes).	B	0 < V < +0.4 @ TTL fan-out of 9 No Tape Malfunction	+2.4 < V < +5 A TTL fan-out of 9 Tape Malfunction	+2.4 < V < +5 @ TTL fan-out of 9 No Tape Malfunction	0 < V < +0.4 @ TTL fan-out of 9 Tape Malfunction

① All RDB and RDF units are reader mode 653 and perforator mode 56X.

Table 3-1. Interface Signal Descriptions (Continued)

Connector Pin	Description	Interface Circuit (Figure 2-2)	① Positive Logic/Mode 5 Levels		① Negative Logic/Mode 6 Levels	
			False Cond. Logic 0 Level	True Cond. Logic 1 Level	False Cond. Logic 0 Level	True Cond. Logic 1 Level
PERFORATOR OPERATION (Cont'd)						
J1-21	Tape Low Output. True condition indicates tape supply nearly exhausted. False condition indicates supply is greater than preset low tape level. For informational purposes only; does not affect operation of the system.		0 < V < +0.4 @ TTL fan-out of 9 Tape Supply Above Preset Level	+2.4 < V < +5 @ TTL fan-out of 9 Tape Low	NOT SELECTABLE - OPERATES IN MODE 5 ONLY	
J1-25	Signal Ground. 0V signal ground reference for all inputs and outputs (isolated from chassis ground). Tied internally to J3-10.					
J2	AC Power Input. See Input Power Specifications, Table 1-2.					
READER OPERATION						
J3-1 thru J3-9	Reader Outputs of Data Tracks 1 through 8 and Synthetic Feed Hole (SFH). Synthetic feed hole is an exact duplicate of the feed hole but free from noise and jitter. Data envelops sprocket by at least 100 usec. on both rising and falling edges.	C	0 < V < +0.4 @ 16 mA (sink) No Hole	+2.4 < V < +5.0 @ 0.2 mA (2.2K to +5V) No Hole	+2.4 < V < +5.0 @ 0.2 mA (2.2K to +5V) No Hole	0 < V < +0.4 @ 16 mA (sink) Hole
J3-10	Signal Ground. 0V signal ground reference for all inputs and outputs (isolated from chassis ground). Tied internally to J1-25.					
J3-11	DL, Drive Left Input. A drive state moves reader tape to the left as described in Section 3.4.2 and 3.4.3.	A	NOT SELECTABLE - OPERATES IN MODE 6 ONLY		+2.4 < V < +5 2K to +5V or open circ. Stop	0 < V < +0.4 @ 4.2 mA max. Drive
J3-12	DR, Drive Right Input. Same as described for J3-11 except for right direction.					
J3-13	System Ready Output. True signal indicates reader is in run (Reader RUN-LOAD switch in RUN) and system power up to operating levels. False signal indicates one or both of above conditions not present.	C	NOT SELECTABLE - OPERATES IN MODE 6 ONLY		2K to +5V Open collector Reader System Not Ready	0 < V < +0.4 @ 40 mA (sink) Reader System Ready
J3-14	High Speed Input. False condition and a true drive signal drives tape asynchronously at 200 char/sec. True condition and a true drive signal drives tape at 300 char/sec. min. See Section 3.4.3.	A	NOT SELECTABLE - OPERATES IN MODE 6 ONLY		+2.4 < V < +5.0 or open circ. Asynchronous Mode Oper.	0 < V < +0.4 @ 5 mA max. High Speed Mode Oper.
J3-15	Reader Ready Output. True condition indicates reader is stopped and ready to accept the next command. False condition indicates reader is advancing tape.	C	NOT SELECTABLE - OPERATES IN MODE 6 ONLY		2K to +5V Open collector Reader Not Ready	0 < V < +0.4 @ 40 mA (sink) Reader Ready

① All RDB and RDF units are reader mode 653 and perforator mode 56X.

- d. Place the perforator RUN-LOAD switch in the RUN position.
- e. Depress the FEED switch and verify that tape is advancing properly. The Punch Command line must be held in the false state while feeding with the FEED switch. On RAF and RDF units, approximately three folds of tape must be placed in the take-up tray so the tape will fold properly. Depress the FEED switch again and verify that tape is folding properly in the take-up tray.
- f. Empty the chad bin each time a new box or roll of tape is installed. This is important to prevent chad from backing up into the punch.
- g. The tape perforator portion may now be operated in one of the three modes described in Sections 3.3.2 through 3.3.4. It is recommended that the punching of fanfolded tapes be limited to 140 feet or less at one time since this is the maximum storage capacity of the fanfold bin on the front panel.

CAUTION

Whenever the punch is operated in mode 5 (especially when the punch is not connected to the normal system, i.e., bench operation), all false level inputs must be tied to 0V (not open circuited). Since most inputs are internally biased to +5V, not tying them to the false (0V) condition in mode 5 could cause erratic operation. Mode 5 systems will not advance tape via the FEED switch unless the Punch Command (J1-11) is held low.

Table 3-2. Front Panel Controls





Switch	Position	Function
POWER	ON	Applies AC power to unit.
	OFF	Removes AC power from unit.
SPOOL (RAB and RDB Units Only)	MOMENTARY ON	Operates manual spooler which winds tape counter-clockwise.
	OFF	Removes control of spooler.
  (Not on RDB Units)	 (Momentary)	Causes reader to drive tape to the right. This is a separate switch on RAF units.
	 (Momentary)	Causes reader to drive tape to the left. This is a separate switch on RAF units.
	OFF	Allows reader to be controlled by external signals

Table 3-2. Front Panel Controls (Continued)

Switch	Position	Function
DUP (RDB and RDF units only)	ON	Allows punch to duplicate the tape being read in the reader.
	OFF	Allows punch and reader to operate in normal mode of operation.
LOAD	ON	Inhibits Reader and applies false signal to Reader System Ready output at J3-13.
	OFF	Allows Reader to operate and applies true signal to System Ready output at J3-13.
FEED/ DELETE	FEED (Momentary)	Causes punch to feed tape and punch feed holes only, at approximately 75 cps. Data input lines will be inhibited (Note: The punch command line J1-11 must be held false while operating this switch.)
	DELETE (Momentary)	Same as FEED except enters an all-hole character on each line of the tape.
PERFORATOR STATUS LAMP	Illuminated	Indicates tape supply is nearly exhausted or with optional Chad Detector, indicates chad level is above predetermined height. Low tape condition does not affect punch system operation but chad error inhibits punch until punch drawer is emptied and the Chad Detector circuit is reset. See Section 3.6.
RUN-LOAD	RUN	Allows operation of the punch mechanism and tape supply system.
	LOAD	Disengages the pinch roller from the capstan on the punch mechanism and places the Tape/Chad Error output in the true condition.

3.3.2 TAPE FEED/DELETE MODE

This mode of operation allows the unit to feed tape through the punch mechanism at approximately 75 cps and punch feed holes only or an all hole delete code.

- a. Make sure tape has been threaded into the punch. See Section 3.3.1, steps a through c.
- b. Place the POWER switch in the on (lighted) position.
- c. Place the perforator RUN-LOAD switch in the RUN position.
- d. Place the TAPE FEED/DELETE switch into its FEED position to punch tape with feed holes only or into its DELETE position to punch tape with the all hole delete code until the desired amount of tape has been punched.

3.3.3 ASYNCHRONOUS FORWARD MODE

In this mode of operation, the unit will punch feed holes and data holes at up to 75 cps in the forward direction under control of input signal lines. See Figure 3-1 for proper timing. On RDB3075 and RDF3075 units, make sure the duplicator cable is removed between J1 and J3 unless the unit is to be operated as a duplicator. If it is see Section 3.5.

- a. Perform Section 3.3.1, steps a through d.
- b. Check to see that the Punch Ready Output at J1, pin 12, is in the Ready state, depending upon the mode. See Table 3-1.
- c. Check to see that the System Ready Output at J1, pin 13, is between 0V and +0.4V.
- d. On units with the Chad Detector option make sure the perforator status lamp is not lighted. If it is lighted due to excessive chad, punching will be inhibited.
- e. Check to see that the Tape/Chad Error Output at J1, pin 20, is in the false (No Malfunction) state, depending upon mode. See Table 3-1.
- f. Apply a forward signal $+2.4 < V < +5.0$ or open circuit to the Direction Input Line at J1, pin 10. Direction input must be stable for 500 nsec., min., before the punch command is given (step g). See Figure 3-1.
- g. Apply a true (hole) signal to each pin (J1, pin 1 through J1, pin 8) for the desired tracks to be punched depending upon the mode. See Table 3-1 and Figure 3-1. Data commands must be present at the time a punch command is initiated (step g) and must remain on the line for 2 usec. (min.) after the punch command input reaches the true level.
- h. Apply the true (punch command) signal to J1, pin 11, depending upon the mode. See Table 3-1. The tape will advance one row and punch a feed hole plus those data tracks which are true (step f).
- i. Repeat steps b through g for each line to be punched.

3.3.4 ASYNCHRONOUS REVERSE MODE

In this mode of operation, the unit will move tape in the reverse direction under control of input signals up to 75 cps for 10 rows (1 inch), without punching data or feed holes.

- a. Perform Section 3.3.1, steps a through d.
- b. Check to see that the Punch Ready Output at J1, pin 12 is in the Ready state, depending upon the mode. See Table 3-1.

- c. Check to see that the System Ready Output at J1, pin 13, is between 0V and +0.4V.
- d. On units with the Chad Detector option make sure the perforator status lamp is not lighted. If it is lighted due to excessive chad, punching will be inhibited.
- e. Check to see that the Tape/Chad Error Output at J1, pin 20, is in the false (No Malfunction) state, depending upon mode. See Table 3-1.
- f. Apply a reverse signal between 0V and +0.4V to the Direction Input line at J1, pin 10. Direction input must be stable for 500 nsec., min., before the punch command is given (step f). See Figure 3-1.
- g. Apply the true (punch command) signal to J1, pin 11, depending upon the mode. See Table 3-1. The tape will backspace one row without punching sprocket or data.
- h. Repeat steps b through f for each line to be backspaced up to 10 lines (1 inch) maximum.

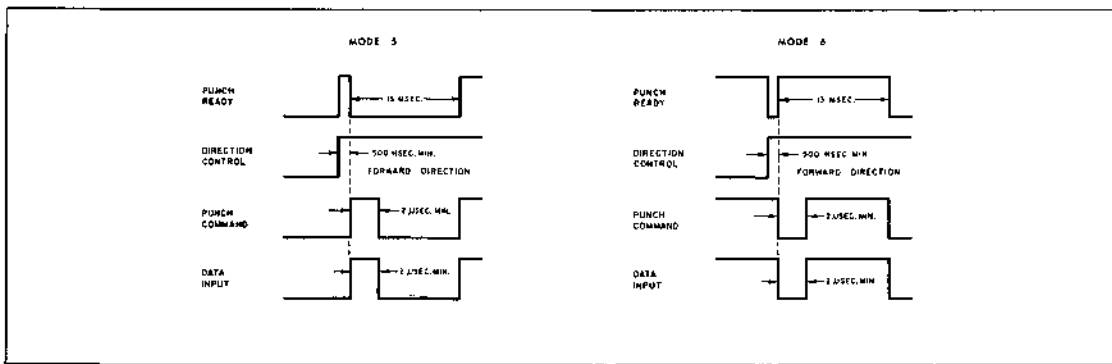

MMC 300

Figure 3-1. Timing Diagram, Perforator Section

Perform the following procedures when operating the reader portion of the reader/perforator system. Refer to Figures 1-1 or 1-2 for locations of switches.

3.4.1 TAPE LOADING AND THREADING, READER

Use the following procedure when loading tape into the reader:

- a. Place the POWER switch into its on position (lighted).
- b. Place the LOAD switch in its on position (lighted).
- c. Place the lower tape guide located on the right side of the sprocket wheel into its open (down) position. Hold it in its open position by moving the torsion spring (located below the lower tape guide) forward.
- d. RAB and RDB Units: Place the roll of tape to be read on the spooler. During drive right tape reading, the sliding hub is pushed back behind the circular plate and the roll of tape is placed on the shaft. If a loop of tape is used, proceed to step e. RAF or RDF Units: Place the fanfolded tape in the right bin for drive left reading or in the left bin for drive right reading.
- e. Insert the tape between the upper and lower tape guides and engage the sprocket holes in the tape with the sprocket drive wheel pins. Make sure the tape is on top of the tape guide shaft and flush with the front and rear tape guide edges (located to the left of the read head).
- f. RAB and RDB Units: Insert the tape over the tape roller located to the right of the read head assembly. RAF or RDF Units: Insert the tape over the right tape guide located at the entrance of the right tape bin (for right direction reading) or over the left tape guide located at the entrance to the left bin (left direction reading).
- g. Raise the lower tape guide to its closed (upper) position (so that it guides the tape into the sprocket wheel) and lock it in its upper position by moving the torsion spring to its rear position. Check for proper alignment of the tape within the sprocket and the front and rear edges of the tape guide.
- h. Place the LOAD switch in its off position (unlighted).
- i. The reader may now be operated in one of the four modes listed in Section 3.4.2 through 3.4.4.
- j. To wind tape back onto spooler (RAB or RDB units) pull the sliding hub out as far as it will go and insert the end of the tape into the slot. Depress the SPOOL switch until the tape is rewound.
- k. To unload tape, stop tape movement and place the LOAD switch in its on position (lighted).
- l. Place the lower guide in its bottom position and remove the tape.
- m. To remove power, place the POWER switch into its off position (unlighted).

3.4.2 TAPE DRIVE, ASYNCHRONOUS OPERATION, EXTERNAL INPUT

In this mode of operation, the reader is controlled from an external signal as follows:

- a. Perform Section 3.4.1, steps a through h.
- b. Make sure the High Speed input at pin 14 of J3 is between +2.4 and +5.0V or an open circuit. Also make sure the Reader Ready signal at pin 15 of J3 is in the true (low) condition. See Table 3-1 and Figure 3-2.

Apply the following drive left (\overline{DL}) signal to pin 11 of J3 or the drive right (\overline{DR}) signal to pin 12 of J3 as required.

Stop: $+2.4 < V < +5.0$ (2K to +5V) or an open circuit

Run: $0 < V < +0.4$ @ 5 ma.

Tape will be driven at 200 characters/second. To stop on character, the run signal must be removed within 1 millisecond after the leading edge of the feed hole. Next drive signal may be applied any time after Reader Ready signal comes true. See Figure 3-2, Timing Diagram A.

If a pulse is used, the pulse must remain true until Reader Ready signal goes false (approximately 1 μ s). The next pulse may be applied any time after the Reader Ready signal comes true (approximately 5 ms between pulses). See Figure 3-2, Timing Diagram B.

- c. Only one run signal must be present at one time. If both run signals are present, the reader will drive to the right.

3.4.3 TAPE DRIVE, HIGH SPEED OPERATION

Use the following procedure when operating the reader in high speed operation, i.e., 300 characters/second.

- a. Perform Section 3.4.1, steps a through H.
- b. Make sure the Reader Ready signal at pin 15 of J3 is in the true condition depending upon mode. See Table 3-1 and Figure 3-2, Timing Diagram C. Also make sure the High Speed input at pin 14 of J3 is between 0 and +0.4V. Apply the following drive left (\overline{DL}) signal to pin 11 of J3 or the drive right (\overline{DR}) signal to pin 12 of J3 as required.

Stop: $+2.4 < V < +5.0$ (2K to 5V) or an open circuit

Run: $0 < V < +0.4$ @ 5 ma.

Tape will be driven at 300 characters/second, min. Tape will stop on character if drive command is removed in less than 100 μ s after leading edge of next sprocket. Next continuous drive command must be present within 100 μ s after the leading edge of the sprocket or else the drive commands may be locked out for up to 20 ms. Within this 100 μ s period, the Reader Ready signal should not be sampled since it will be false but the drive command (if required) should be reapplied. The Reader Ready true condition is required only at the initial drive command or after the 20 ms lockout. See Figure 3-2, Timing Diagram C.

If a pulse is used, the pulse must remain true until the Reader Ready signal goes false (approximately 1 μ s) and the next pulse may be applied under the same conditions as described in the previous paragraph for continuous drive command.

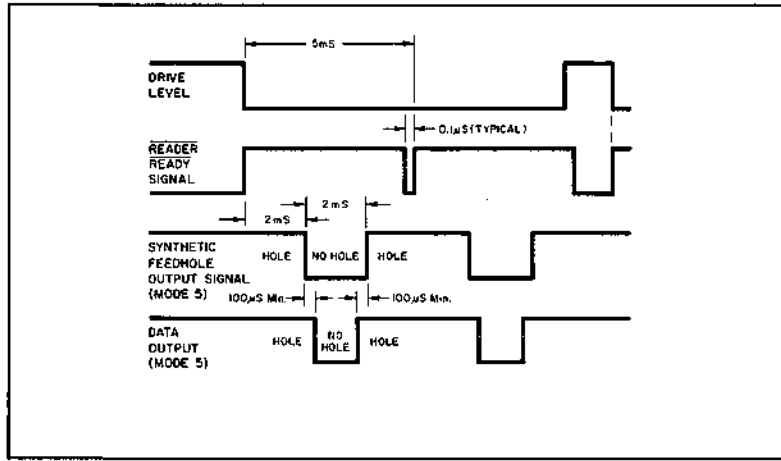

TIMING DIAGRAM A

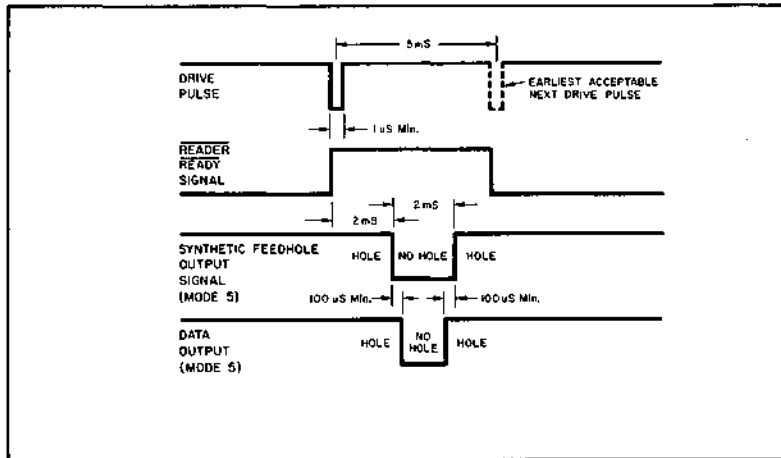

TIMING DIAGRAM B

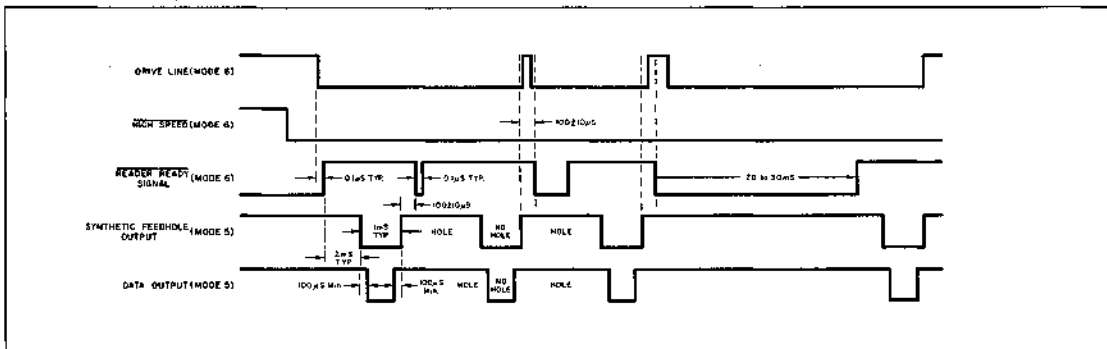

TIMING DIAGRAM C

Figure 3-2. Timing Diagram, Tape Reader Section.

- c. Only one run signal must be present at a time. If both run signals are present, the reader will drive to the right.

3.4.4 ASYNCHRONOUS OPERATION, FRONT PANEL SWITCHES

In this mode of operation, the reader is controlled by the direction switch on the front panel as follows:

- a. Perform Section 3.4.1, steps a through h.
- b. Make sure the external control signals, \overline{DL} and \overline{DR} (pins 11 and 12 of J1) are greater than +2.4V (stop condition).
- c. Depress the left direction switch for drive left or the right direction switch for drive right until the desired amount of tape has been read. On RDB units, these switches are not present.

3.5 OPERATING INSTRUCTIONS, DUPLICATOR (RDB and RDF Units)

Perform the following procedures when operating the RDB3075 or the RDF3075 as a duplicator:

- a. Load the tape to be duplicated into the reader by performing Section 3.4.1 steps a through h.
- b. Connect the duplicator cable (REMEX Part No. 110374-1) between the perforator input connector J1 and the reader input connector J3.
- c. Place the DUP switch into its on (lighted) position until the required amount of tape has been duplicated. The punch will duplicate the tape being read in the reader, a line at a time.

3.6 TAPE RECOMMENDATIONS

Table 3-3 lists the tapes REMEX recommends for use. Basic tape specifications are given in Table 1-2.

3.7 OPERATIONAL MAINTENANCE

After every 6 to 8 hours of reader use, the operator should check the tape transport area of the reader for cleanliness. This is extremely important since any dirt or foreign material covering the read head can cause readout errors. For general cleaning, use the bristle brush supplied. Cleaning of the photocell assembly is described in Section 5.3.1.1. Make sure the tape remains clean at all times since any residue picked up by the tape can be deposited on the read head. It has been found in certain cases that residue picked up by the tape comes from soiled hands. It is important that care be exercised when handling

tape, especially in machining areas or other areas where grease, oil and sprays are present.

It is important that the chad tray at the lower left corner of the front panel be emptied periodically to prevent chad from backing up into the punch and creating punching errors. A good practice to follow is to empty the tray when each new roll of tape is installed. See Section 3.3.1, step f. Units containing the Chad Detector option will inhibit punching when the chad level raises above a predetermined level. See Section 3.7.1.

Table 3-3. Acceptable Tapes

Remex has found the following tapes acceptable for use on the system.

Type	Manufacturer	Part Number
Paper, Uncoiled or oiled (see note) except black carbon filled tapes	REMEX	1000 ft Roll, 715200-002 1000 ft Fanfold, 715200-001
	Paper Manufacturer's Inc.	Perfection Series
	Bemis	Paper Tape Series
	Crown Zellerbach	Paper Tape Series
	Friden	Paper Tape Series
Special Paper (roll only)	Nova Tech	Syntosil Machine Tool Tape
Special Mylar, Paper-Mylar or Polyester (roll only)	3M Brand	N/C Tape #401 or #301
	Arvey	RVCZ 60
	Chase Foster	MFM-153515, MFM-103515, or PMP01151

NOTE: Oiled paper tapes may be used but with more frequent punch cleaning periods. ALSO ACCEPTABLE, BUT WITH REDUCED PUNCH LIFE: Black Carbon Filled Tapes. NOT ACCEPTABLE FOR THIS PUNCH APPLICATION: Mylar-Foil, 2.6 mil, Arvey RVCT52 and all other tapes with a thickness less than 3 mil and greater than 4.3 mil.

ALSO NOT ACCEPTABLE: Arvey RVCP23, Numeridex #0500 and all vulcanized fiber tapes.

3.7.1 CHAD DETECTOR RESET

The optional chad detector circuit is triggered when the chad in the chad tray reaches a predetermined height. This will inhibit the punch circuitry until the tray is emptied. After the tray has been replaced, the circuit must be reset by depressing S9 located near the punch. This will reset the circuit until the chad again reaches the preset level. Generally, however, if the chad is emptied after each new roll of tape, the chad detector circuitry will not be triggered.

3.8 TAPE PREPARATION REQUIREMENTS

Proper tape reader operation requires that the maximum accumulated longitudinal error between feed hole centers in the punched tape be ± 0.025 inch within any span of 5 inches, as specified in the American National Standards Institute Standard X3.18-1967 (ANSI: formerly United States of America Standards Institute). In the event a user has, because of punching problems, a number of tapes which do not conform to this specification by an amount consistently out of tolerance, the reader may be set up as in Section 5.6.2 using one of these tapes rather than the type specified.

A tape gauge is included at the rear of the RPM1075 manual so that the ± 0.025 tolerance specification can be checked. To use the gauge, place the feed hole of one end of a 5 inch span (50 characters) at the single cross hair and swing the other end of the 5 inch span in the arc until one of the cross hairs is centered in the feed hole. Read the measurement adjacent to that cross hair (plus tolerances to the right and minus tolerances to the left). A second 5 inch gauge is printed at the bottom to check both longitudinal and perpendicular transverse center line spacing.

SECTION IV
THEORY OF OPERATION

4.1 BLOCK DIAGRAM DESCRIPTION

The REMEX tape reader/perforator system performs three basic functions: (1) controls the operation of the RPM1075 punch mechanism in response to the input control signals, (2) reads small rolls (RAB and RDB units) or fanfolded (RAF and RDF units) tapes, and (3) duplicates tapes read by the reader (RDB and RDF units only). Each function is described below in block diagram form and illustrated in Figures 4-1, and 4-2. See also the system schematics, Figures 8-1 through 8-4. Electronic descriptions are given in Section 4.2.

4.1.1 TAPE PERFORATION CONTROL

Two logic cards are used to control the punch mechanism: (1) Control Logic and Feed Hole Driver Card and (2) Data Logic and Driver Card. The former controls the logic and timing of the perforator and the direction of tape movement while the latter controls the data logic and solenoid driver amplifiers. Refer to Block Diagram, Figure 4-1.

Proper operation requires that the direction and data inputs be present when the punch command is given. See Sections 3.3.3 and 3.3.4. Applying the punch command starts the timing of single shot SS1 and initiates the Data Clock Pulse. During the SS1 time period, coil L1, L2, or L3 is energized, depending upon the state of the L1-L3 counter and the direction present, causing tape to be advanced (or back-spaced) one line. At the same time, the Data Clock Pulse latches the data track information in the data latch circuits Z3 and Z7. This presents the track data to the input of the data amplifiers Q1-Q8.

When SS1 times out (tape advanced), SS2 and SS3 are triggered and begin their time periods. SS2 is used to update the L1-L3 counter, to turn on the feed hole solenoid amplifier which operates the feed hole solenoid, and to generate the Punch Clock signal. The Punch Clock signal is used to turn on those data amplifiers, Q1-Q8, which have logical ones present at their input. The data amplifier outputs, in turn, operate their respective punch solenoids.

The period of SS3 runs concurrent with SS2 but lasts a short time longer to make sure the punch pins are clear of the tape and the punch is ready to accept the next advance command. At the end of SS3, the Punch Ready signal becomes true signaling the external equipment that the system can accept the next line of information.

Switch S1, FEED/DELETE, provides a second input to the punch signal interface logic which also generates the Punch Command Pulse. An identical sequence is produced as previously described for the Punch Command except that in the FEED position this signal also inhibits the data track signals on the Data Logic and Driver Card resulting in only feed holes being punched. In the DELETE position all data tracks are enabled so that the all hole delete code is punched.

On RAB and RDB units, switches S6 and S7 (S6 only on RAF and RDF units) combine to provide a Tape Handling Error Signal which is amplified on the Control Logic and Feed Hole Driver Card and paralleled with the optional Chad Error signal to provide the Tape/Chad Error signal to external equipment. This signal is present when one of the following conditions occurs: (1) the RUN-LOAD switch S6 is in LOAD or (2) a supply error is present (supply tape too loose or tight causing S7 to open; RAB3075 and RDB3075 units only). This removes the 0V signal causing the Tape Handling Error Amplifier on the Control Logic and Feed Hole Driver Card to turn on and give a true Tape/Chad Error Signal System.

On systems containing the Chad Detector Option, a 0V true Chad Error signal is generated by the Chad Detector Card when chad in the tray reaches a predetermined level. This signal is paralleled with the Tape Handling Error signal on the Control Logic and Feed Hole Driver Card to give a true Tape/Chad Error Signal to external equipment.

4.1.2 READER DRIVE CONTROL

Step Motor Driver card 109891-6X1 to control tape movement. Figure 4-2 shows the Block Diagram for this card. The electronic details are described in Section 4.2.3. The drive system consists of a stepping motor which is directly coupled to the sprocket drive wheel. Each pulse to the motor advances it either 15° clockwise or 15° counterclockwise and, in turn, causes the sprocket to advance the tape one line. The tape stops on character and waits for the next motor pulse.

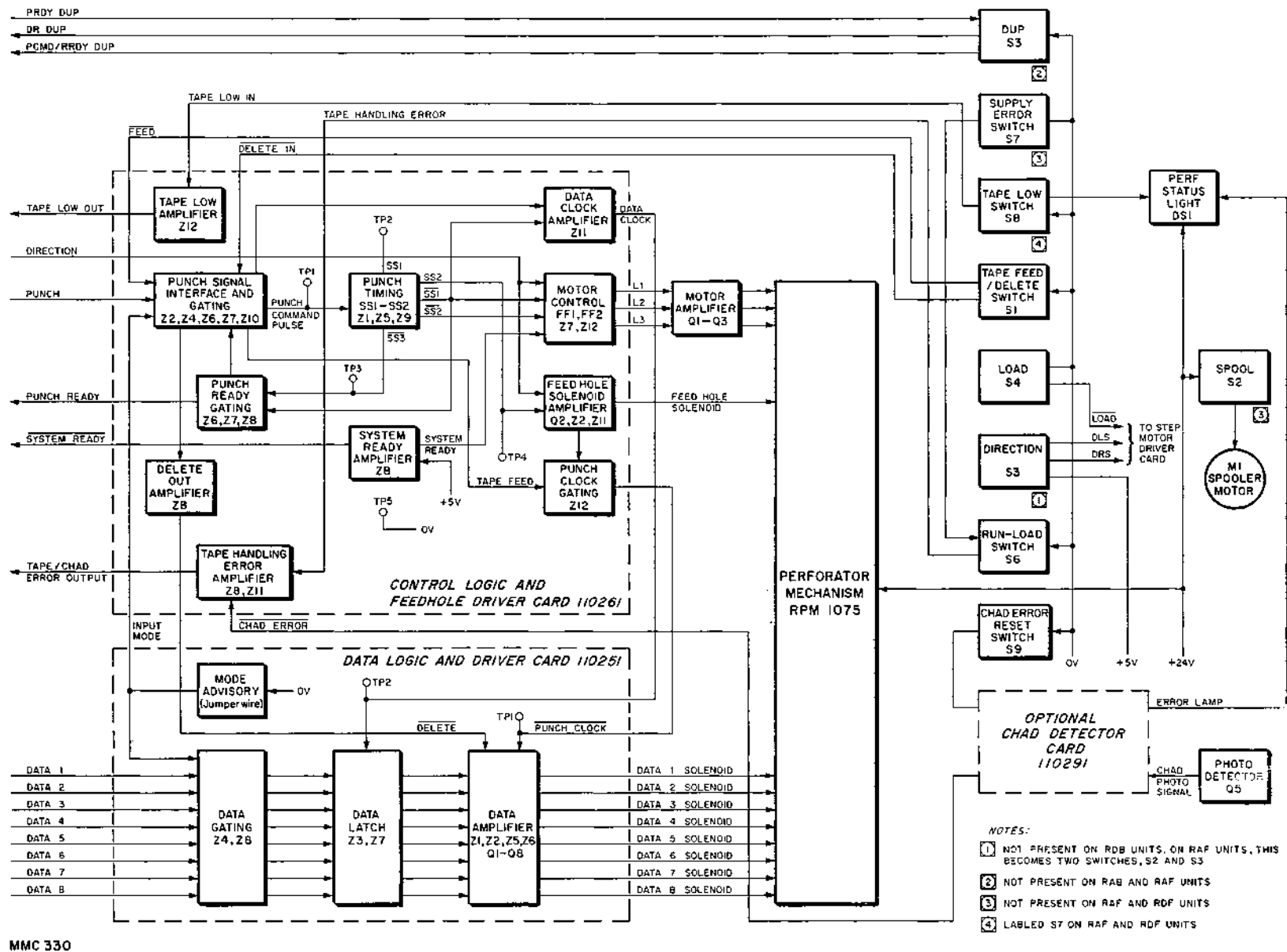

MMC 330

Figure 4-1. Block Diagram, Punch Control Section

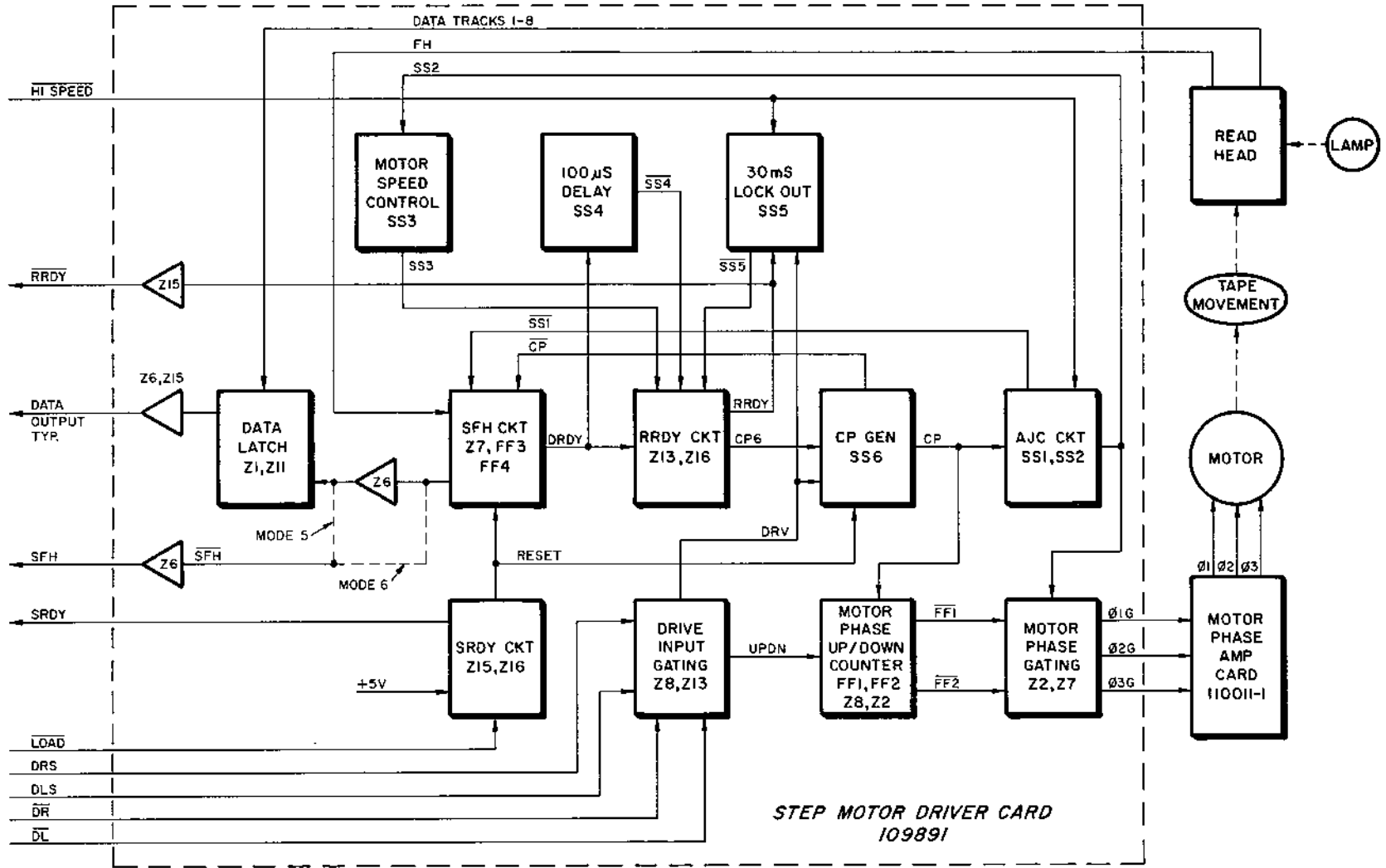

MMC 295

Figure 4-2. Block Diagram, Step Motor Driver Card 109891-6X0.

The step motor driver card is used to generate the required motor pulse signals in response to the drive inputs for either asynchronous operation (Section 3.4.2) or high speed operation (Section 3.4.3). When the Hi Speed input is false (+5V or open circuit) and an OV true drive signal applied to either the drive left or drive right line or a command from either direction control switch, S2 or S3, will generate the first system clock pulse, CP. The CP signal is used to advance the motor phase control flip-flops and trigger the anti-jitter control (AJC) circuit. Gated outputs from the flip-flops step the motor and the anti-jitter control output prevents oscillation of the motor and sprocket and, in turn, the sprocket outputs.

When the next feed hole is read and single-shot SS3 times out, the Reader Ready (RRDY) signal is generated. It is this signal which initiates the next CP. All subsequent CP signals are also generated in this manner. The motor speed control circuit is adjusted to control the reader speed at 200 characters/second. When the High Speed line is true, SS2 and SS3 are disabled. The generation of the first CP is identical to that just described. However, as soon as the next feed hole is read, SS4 is triggered causing $\overline{SS4}$ to be present for 100 us. If the reader is to stop on that character, the drive signal must be removed during this 100 us period or else the next CP will be generated, causing the tape to step one more line. Thus with the elimination of SS2 and SS3 (SS1 is also shortened), a 50% faster stepping rate can be obtained.

Because sprocket wheel oscillation is inherent with stepping motors and because anti-jitter circuit is eliminated in High Speed operation, the sprocket will oscillate as it stops on character. This oscillation is even more apparent if the drive signal is removed and not reapplied before $\overline{SS4}$ times out to the extent that the sprocket may move off and back on character a number of times. To prevent this from appearing on the outputs, the SFH and data outputs are latched up using Z1, Z7 and Z11. It is also necessary to allow the sprocket to settle before applying the next drive signal. This is accomplished by SS5 which is enabled by the Reader Ready line. If a new drive signal is applied after $\overline{SS4}$ times out, SS5 becomes energized. This locks out any drive signal for up to 30 ms and allows the sprocket to settle before the next drive signal generates the next CP signal. A system ready circuit is also included using Z15 and Z16 to provide an external signal when the unit is not in load and when power is up to operating levels.

4.1.3 TAPE READING

The tape reading circuits are located in the read head assembly and consist of a hybrid arrangement of discrete components which are used to sense the punched tape perforations and convert them into output signals. As tape is advanced over the read head by the sprocket drive, photovoltaic cells in the read head are energized by the light source when the corresponding holes are present in the tape. The photocell output is subsequently amplified and routed to the output plug. Tape guiding is achieved by the front and rear tape guide edges located to the left of the photoelectric sensor assembly and the use of the sprocket wheel pins.

4.1.4 MANUAL SPOOLER OPERATION

RAB and RDB 3075 units are equipped with a motorized hub (M1) operated by the SPOOL push button. The hub is moveable and is pushed back behind the circular plate during drive right tape reading, allowing a small roll of tape to be placed on the shaft. To rewind the roll back onto the hub, the hub is pulled out as far as it will go, the end of the tape inserted into the slot on the hub and the SPOOL push button depressed until tape is rewound.

4.1.5 DUPLICATION MODE OPERATION

RDB and RDF 3075 units are provided with a duplication cable which connects between the perforator input connector J1 and the reader connector J3. These units are also supplied only with reader mode 653 and perforator mode 56X for compatibility. When the cable is connected and the DUP switch, S3, is operated as described in Section 3.5, OV is removed from the punch command input at J1-11 allowing it to be controlled only by the $\overline{\text{RRDY}}$ OUT line at J3-15. See Figure 8-2 or 8-4. OV from C3 is also applied from S3 to the $\overline{\text{DR}}$ IN line on the reader at J3-12 causing it to advance tape. Immediately, the $\overline{\text{RRDY}}$ OUT line goes positive which causes those holes still present in the reader to be punched. The tape then advances to the next character where it stops and waits for the next drive signal. This signal comes from the Punch Reader output at J1-12 in the form of a negative going pulse which is coupled through C3 to the $\overline{\text{DR}}$ IN line on the reader and the sequence is repeated.

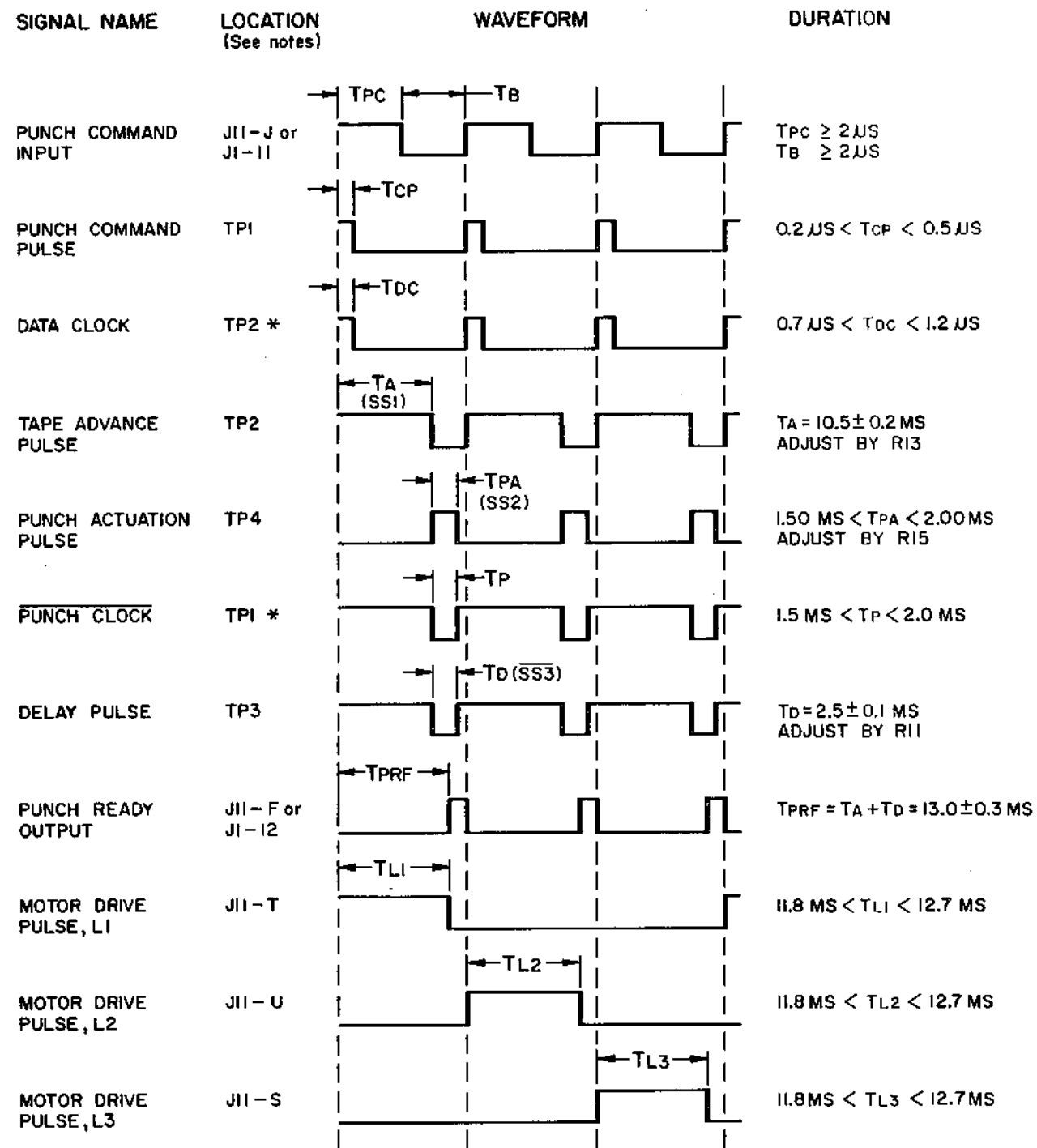

NOTES: 1. ALL LOCATIONS EXCEPT (*) ARE ON CONTROL LOGIC AND FEED HOLE DRIVER CARD. LOCATIONS MARKED WITH (*) ARE ON DATA LOGIC AND DRIVER CARD ALTHOUGH THESE SIGNALS ARE GENERATED ON THE CONTROL LOGIC AND FEED HOLE DRIVER CARD.

MMC 328

Figure 4-3. Waveforms and Timing Diagram, Perforator Section.

This section describes the theory of operation and electronic details of the five circuit cards used in the tape perforator system.

4.2.1 CONTROL LOGIC AND FEED HOLE DRIVER CARD 110261

This card controls the punch timing and logic and the operation of the feed hole solenoid. Punching is accomplished by using (1) external Punch Command, Direction and Data Input signals (2) the FEED switch to punch feed holes only, or (3) the DELETE switch to punch the all hole delete code on the tape. In addition this card generates two other output signals: (1) the Tape/Chad Error signal and (2) the Tape Low output. The schematic for this card is given in Figure 8-5.

4.2.1.1 Punch Command Control

Before the Punch Command can be applied, the following signals must be present as described in Sections 3.3.3 and 3.3.4: (1) the Punch Ready output signal must be true indicating the punch is cleared and ready for the next line input, (2) a Direction Control signal must be present, (3) the desired Data Input signals must be present, and (4) the FEED and DELETE switches must be in their off positions. See Table 3-1 for the voltage levels of the input signals corresponding to the particular mode being used. Also see Figure 4-3 which shows the waveforms at selected points on the Control Logic and Feed Hole Driver card.

Applying the Punch Command signal at J1-11 produces a +5V output at Z7-11 since the true level of the Punch Command signal is of the opposite polarity to that of the Input Mode signal at Z7-13. Refer to Figure 8-5. The Input Mode signal originates on the Data Logic and Driver card; See Section 4.2.2. As Z7-11 (and Z10-4) goes to +5V, Z10-6 also goes to +5V which places Z4-8 at 0V until C4 charges (between 0.2 and 0.5 us). This signal is inverted to +5V at Z11-4 and is used as the positive going Data Clock signal (applied to the Data Logic card). Z4-8 is also inverted at Z8-12 and applied to Z6-5. Since Z6-4 is already +5V ($\overline{SS1}$ and $\overline{SS3}$ are at +5V) Z6-6 goes positive and is used (1) to trigger single-shot SS1 and (2) as the CP signal for the two direction control flip-flops FF1 and FF2. SS1 is adjusted by R13 for a period of 10.5 ± 0.2 ms.

Flip-flops FF1 and FF2 are connected through Z7 and Z12 to form a three state counter which determines the energizing sequence of the punch motor windings L1, L2 and L3. The direction of counting is determined by the direction line which places +5V at pins 1 and 10 of Z7 for the forward direction (L1, L2 and then L3 energizing sequence) or 0V for the reverse direction (L1, L3 and then L2 energizing sequence). Figure 4-3 illustrates the forward direction and assumes FF1 and FF2 are initially in their reset states. The outputs of FF1 and FF2 are gated at Z10, pins 2, 9 and 13 with the negative going $\overline{SS1}$ and $\overline{SS2}$ signals from Z6-3 to cause L1, L2 or L3 (depending upon the state of the counter) to go positive for the time period of SS1 and SS2 (approx 12.35 ms).

When SS1 times out, the positive-going edge of $\overline{SS1}$ triggers SS2 and SS3. SS2 is a positive-going signal and is gated at Z2-10 with the Direction signal. If the Direction signal is +5V (forward), Q2 is turned on which energizes the Feed Hole Solenoid causing a feed hole to be punched; if the Direction signal is 0V (reverse), Q2 stays off and no feed hole is punched. The 0V true output at pin 8 of Z2 is also gated with the 0V FEED switch signal from Z2-6 causing a 0V true Punch Clock output at Z12-3 which is used on the Data Logic card. If the direction is reverse, Z12-3 remains at +5V and the data is inhibited (See Section 4.2.2). The pulse width of SS2 is set between 1.40 and 2.0 msec. and is adjusted by R15.

SS3 is set by R11 for a 2.5 ± 0.1 msec. on time period which is slightly greater than SS2. This delay pulse is inserted to make sure the punch pins have recovered and that the system is ready for the next Punch Command input. When SS3 times out, the positive going $\overline{SS3}$ signal is gated at Z6-13 causing Z6-11 and Z6-8 to be +5V ($\overline{SS1}$ at Z6-12 is already +5V). The Punch Ready output at Z7-6 then becomes true (0V or +5V depending upon the mode) and indicates to the external equipment that the punch system is ready for the next Punch Command input.

4.2.1.2 FEED Switch Operation

The FEED switch sequence generates almost the same sequence as described for the Punch Command input; see Section 4.2.1.1. Actuation of the FEED switch applies 0V to Z2-5 which locks up the latch composed of Z2, pins 1-6 and places 0V at Z2-3 (Z2-1 is approximately +3V due to the R8-R9 divider). As Z2-3 goes to 0V, Z4-11 becomes +5V and generates a +5V signal at Z10-6. The same sequence as described for the Punch Command signal in Section 4.2.1.1 occurs except only a feed hole is punched

since the +5V signal at Z2-6 holds the Punch Clock signal at +5V. When SS3 has timed out and Z6-8 goes positive, the 0V signal at Z2-8 is capacitively coupled to Z2-1 through C7. This places a negative pulse at Z2-1 which shuts off the feed cycle until C7 charges. After C7 charges, the cycle is repeated, providing the FEED switch is still actuated. It is necessary when using the FEED switch that the Direction Input be +5V or open circuit to place the FF1-FF2 counter in the forward sequence of operation.

4.2.1.3 DELETE Switch Operation

The DELETE switch is provided as a means of placing an all hole code on the tape manually. Actuating the DELETE switch places 0V at Z4-5 which locks up the latch composed of Z4, pins 1-6 and places 0V at Z4-3 (Z4-1 is approximately +3V due to R8-R9 divider). As Z4-3 goes to 0V, Z4-11 becomes +5V and generates a +5V signal at Z10-6. The same sequence as described for the Punch Command signal in Section 4.2.1.1 occurs. In addition the +5V signal at Z4-6 is inverted at Z8-8 and applied to the Data Logic card causing all holes to be punched. When SS3 has timed out and Z6-8 goes positive, the 0V signal at Z2-8 is capacitively coupled to Z4-1 through C7. This places a negative pulse at Z4-1 which shuts off the feed cycle until C7 charges. After C7 charges the cycle is repeated, providing the DELETE switch is still actuated. It is necessary when using the DELETE switch that the Direction Input be +5V or open circuited to place the FF1-FF2 counter in the forward sequence of operation.

4.2.1.4 System Ready Signal Description

The System Ready signal indicates that the system's voltages have reached the proper operating levels. When power is first turned on, C6 begins charging and continues charging until it reaches the level sufficient to switch the System Ready output at Z8-6 to 0V. This signal is then inverted at Z8-4 and applied to the Clear input at FF1 and FF2 to set the counter to zero.

4.2.1.5 Tape Handling Signal Description

The Tape Handling Error input signal at Z11-5 is normally 0V as described in Section 4.1.1. Actuation of S6 or S7 removes the 0V signal at Z11-5 which places the Tape/Chad Error output at +5V for mode 5 or 0V for mode 6. The 0V signal at Z11-6 is also applied to Z6-9 which inhibits the Punch Ready output and, in turn, the Punch Command input by causing Z6-8 to go to 0V. Systems which do not require

that the Tape Handling Error inhibit these signals (optional mode XX1) have the jumper wire between Z11-6 and Z6-9 removed.

4.2.1.6 Chad Error Signal Description

The Chad Error signal is generated on the Chad Error detector card and applied to the Control Logic and Feed Hole Driver Card. See Section 4.2.5. A predetermined level of chad in the chad box causes the Chad Error signal to drop to 0V. This signal is applied to Z6-9 which inhibits the Punch Ready output and, in turn, the Punch Command input by causing Z6-8 to go to 0V. In addition, for mode XX0, the 0V Chad Error signal also places the Tape Chad Error output at +5V for mode 5 or 0V for mode 6.

4.2.1.7 Tape Low Signal Description

The Tape Low signal is normally 0V when tape supply is sufficient. When the tape roll drops below a preset level, switch S8 on the tape deck opens and removes the 0V signal from Z12-9 and 10. These pins are now biased through the 2.2K resistor in Z14 to +5V causing pin 8 of Z12 to go to +5V.

4.2.2 DATA LOGIC CARD 110251

This card controls the gating and punching of the data tracks. Because the operation of all eight tracks are identical, only Data 1 will be used in this discussion. Applying the true Data 1 signal (+5V for mode 5 or 0V for mode 6) to Z4-4 switches Z4-6 to +5V since Z4-5 is of the opposite polarity to that of the true Data signal. Refer to the Schematic, Figure 8-6. The input to the 4-bit, bistable Z3 is thus +5V for a true Data input.

Latch Z3 stores the input information at input 1D and transfers it to the output $1\bar{Q}$ (inverted from the input; 0V for true Data signal) when the Data Clock input from the Control Logic and Feed Hole Driver card (See Section 4.2.1.2) goes positive. The \bar{Q} output will follow the data input at 1D inversely as long as the Data Clock remains high. When the Data Clock goes low, the information is retained at the \bar{Q} output until the clock again goes high. With +5V at Z3-2, the output Z3-1 will be 0V and remain at 0V when the Data Clock drops to 0V. The Data Clock occurs simultaneously with the Punch Command signal at Z6-6 on the Control Logic and Feed Hole Driver card (See Section 4.2.1.1). It can be seen, then, that the data inputs must be stable at the time the Data Clock falls (0.2 to 2 usec after the leading edge of the Punch Command).

During the SS2 time period on the Control Logic and Feed Hole Driver Card, the 0V true Punch Clock is generated and applied to the Data Logic and Driver Card at Z1-5 for track 1. If Data track 1 is true, Z2-3 will be 0V causing Z1-4 to go positive. This turns on data 1 solenoid amplifier Q1 and punches track 1.

4.2.3 STEP MOTOR POWER SUPPLY CARD, 109061-2

AC voltage is applied from a secondary winding on transformer T1 and used to generate the +5 VDC for the logic elements. Refer to the schematic, Figure 8-7. The -2 assembly is used on this unit. A five-volt regulator, LM309K is used to develop the +5 VDC. Approximately 11 VDC is applied to the input at pin 1 and with R6 in the ground path at pin 3, an adjustable voltage slightly greater than +5 VDC is present at pin 2. It is subsequently reduced to +5 VDC due to the drop through CR6 and CR7. Adjustment of R6 will provide the required output voltage of 5.00 ± 0.25 VDC. R4 and Q1 provide an adjustable +5.4 VDC for the lamp supply voltage. CR1 and CR2 are used to rectify 48/60 VRMS AC voltage to give the +28/34 VDC range used to operate the stepper motor.

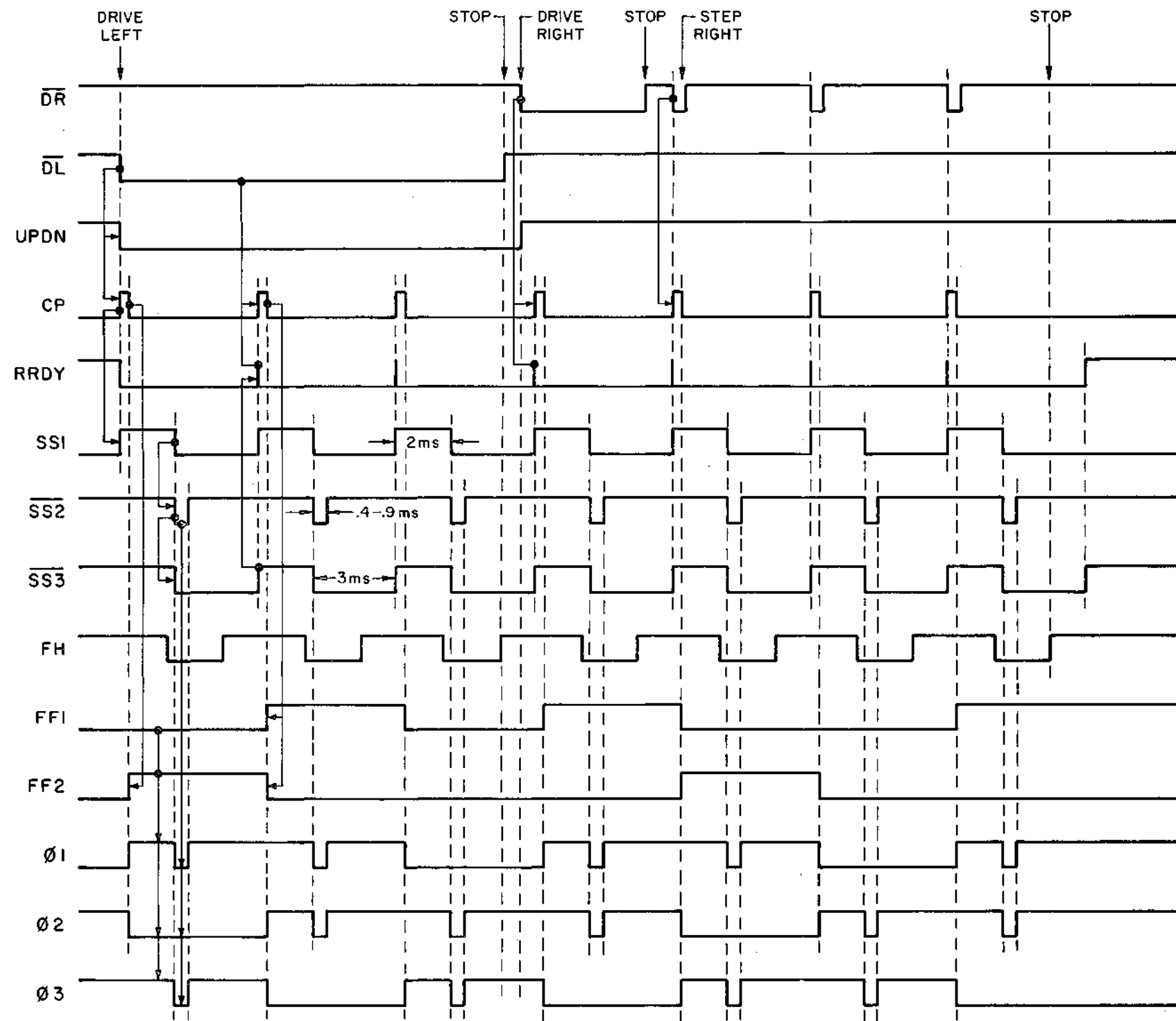

MMC 292

Figure 4-4. Timing Diagram, Motor Control Circuit, Asynchronous Operation

This card is used to generate outputs which drive the three phases of reader stepper motor in response to the drive inputs. It allows the reader to be operated in (1) asynchronous mode as described in Sections 3.4.2 and 3.4.4 or (2) in high speed mode as described in Section 3.4.3.

4.2.4.1 Motor Control Circuit Description, Asynchronous Modes

The following description assumes initially that tape is stopped and no drive signal is present. Figure 4-4 shows waveforms at selected points for drive left, drive right, stop and step right operations. The figure begins at the extreme left with tape stopped after being driven to the right. The chart is intended as a guide to show the sequence of events and which signal initiates other signals (originating signal or signals shown by dot end of arrow and resulting signal shown at arrow head). It must be cautioned that due to the wide range of pulse widths, no attempt has been made to draw the time axis to scale. Also refer to the schematic, Figure 8-8.

With the reader stopped, the FH signal is +5V true and all single-shots have timed out (their \bar{Q} outputs are +5V). FF3 is in the clear state (DRDY, data ready signal at the \bar{Q} output is +5V) having been reset by the previous positive going edge of FH. This places Z16, pin 3 (RRDY, Reader Ready) at +5V and the external \overline{RRDY} (Ready) at 0V indicating the reader is ready to accept the next command.

Figure 4-4 shows the \overline{DL} (drive left) signal being applied first. Note that the external inputs are paralleled by their respective switch inputs (SL or SR) so that either input will generate the following sequence of events. The 0V true \overline{DL} signal switches the \overline{DLG} (drive left gate) at pin 8 of Z8 from +5V to 0V which causes the Z13 flip-flop (pins 1 through 6 of Z13 are connected to form a flip-flop) to change state and switch the UPDN (Up-Down) line from +5V to 0V. The \overline{DLG} signal also switches the DRV (Drive) line at Z13, pin 11, from 0V to +5V. This triggers SS6 and generates the positive going CP signal (approximately 0.25 us).

The CP signal is used three places: (1) as the clock input for the two motor phase control flip-flops, FF1 and FF2, (2) to trigger single-shot SS1, and (3) to set FF4 (the complement, \overline{CP} , is fed to Z12, pin 4). Outputs $\overline{FF1}$ and $\overline{FF2}$ are gated at Z2 and Z7 and used to generate the three phase outputs for the motor windings, which

are subsequently amplified by the Reader Motor Amp card 110011. See Section 4.2.5 also see schematic Figure 8-9. Flip-flops FF1 and FF2 are connected through Z8 to form a three state up-down counter. The phasing sequence is determined by the UPDN (Up-Down) line which places 0V at pins 1 and 5 of Z8 for drive left (phase sequence order: phase 1, phase 2 and then phase 3) at +5V for drive right (phase sequence order: phase 3, phase 2 and then phase 1). Figure 4-4 illustrates drive left first and assumes FF1 and FF2 are initially in the reset states.

The positive going edge of CP is used to trigger single-shot SS1. R8 adjusts the pulse width of SS1 and should be set for 2 ms (see Section 5.6.4.2). (During High Speed operation, R7 is pulled to 0V in the time constant circuit (R7, R9, R8, C5) which reduces SS1 to approximately 1.5 ms.) At the end of the 2 ms pulse, the negative going edge of SS1 triggers SS2. The 0V level of $\overline{SS1}$ is used to set flip-flop FF3 which is described in Section 4.2.5.2. SS2 is adjusted by R16 for a pulse width of between 0.4 and 0.9 ms as described in Section 5.6.4.2. $\overline{SS2}$ is applied as a negative OR combination to pins 12, 3 and 9 of Z2 and causes the remaining two motor windings which are not energized during any phase sequence to become energized during the SS2 time period. This momentary energizing of all motor phases dampens the inherent oscillation in the stepper motor as it moves from one position to the next.

The positive going edge of SS2 is used to trigger single-shot SS3 at the end of the SS1 time period. R13 adjusts the pulse width of SS3 (see Section 5.6.5) for approximately 2.75 ms so that with it and the 2 ms pulse width of SS1, the time between each CP and hence each character is approximately 4.75 ms or 210 \pm 3 cps (the actual figure is higher than 200 cps in order that the reader can be operated at 200 cps using step pulses). Shortly before SS3 times out, the next sprocket hole is read which resets FF3 and places the DRDY (Data Ready) line at +5V. When $\overline{SS3}$ goes positive, both pins 12 and 13 of Z16 are +5V and the next CP is generated causing the cycle to be repeated (provided the drive signal is still present). The DRDY signal also triggers the SS4 single-shot but in asynchronous operation it has no significance since it times out before SS3. In addition, SS5 is not used during asynchronous mode.

Operation during drive right is very similar except for two major differences: (1) the \overline{DR} signal is now 0V (\overline{DL} is +5V) and (2) the UPDN line is +5V causing the

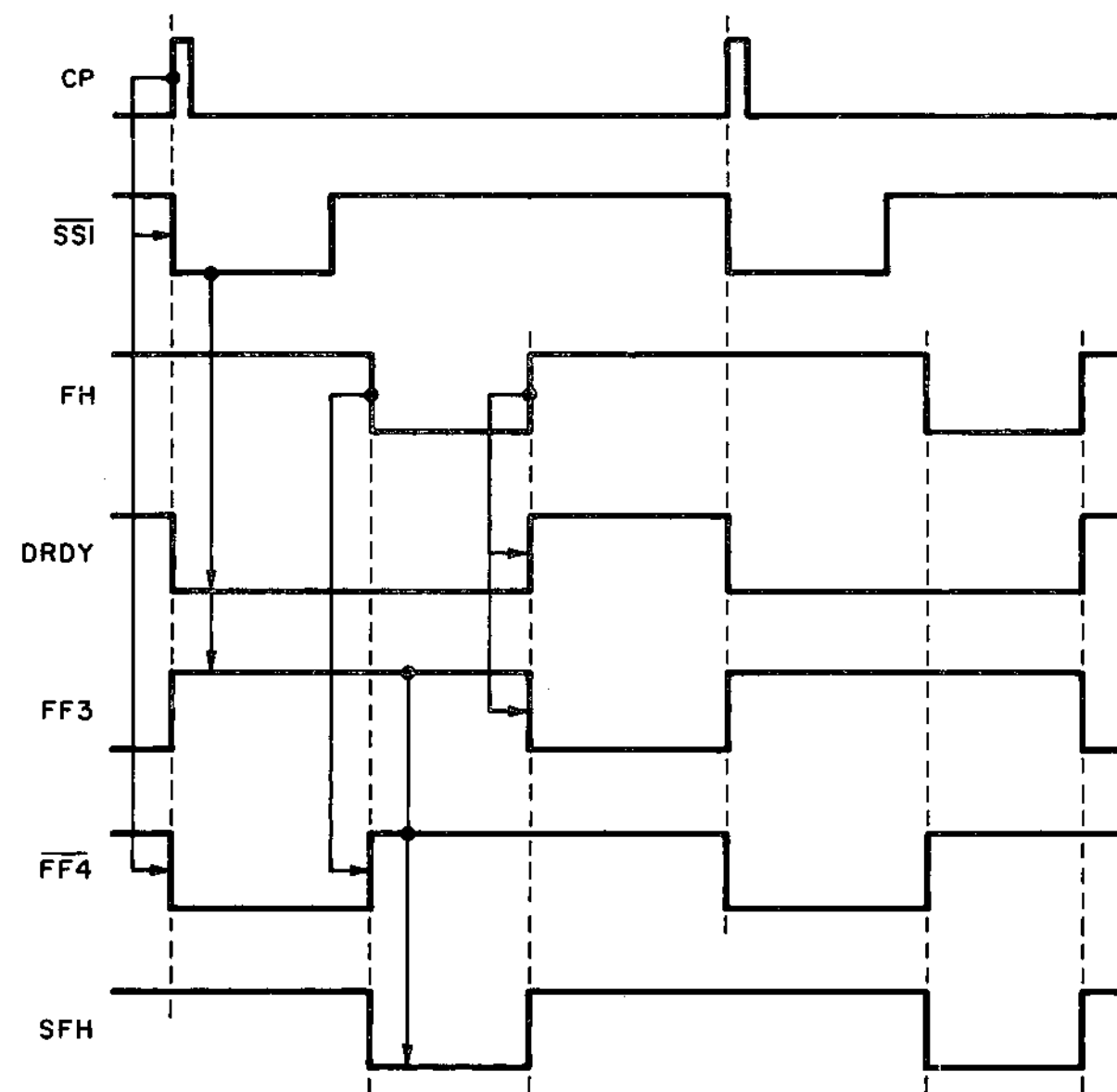

MMC 290

Figure 4-5. Synthetic Feedhole Timing Diagram, Step Motor Driver Card 109891.

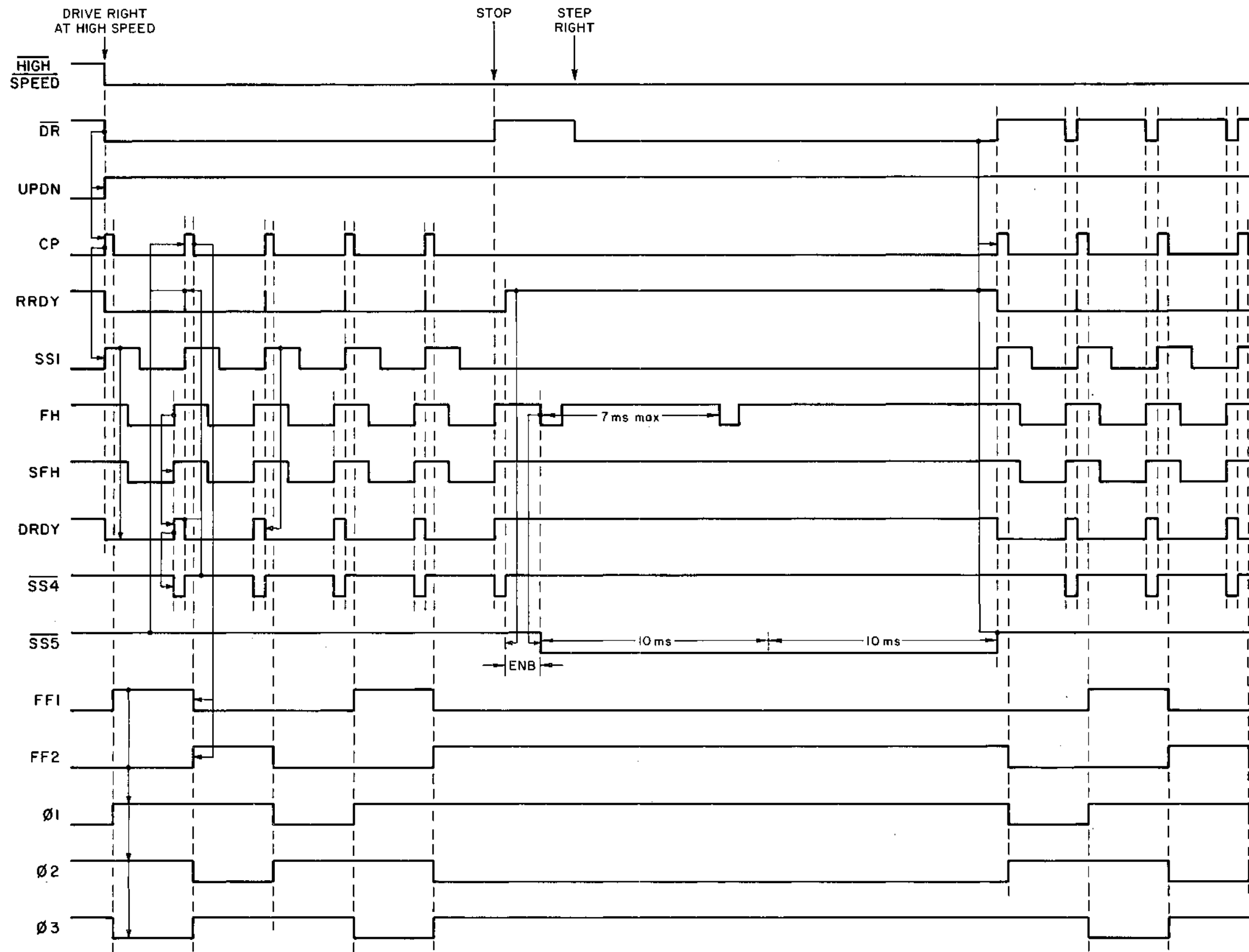

MMC 291

Figure 4-6. Motor Control Circuit Timing Diagram, High Speed Operation, Step Motor Driver Card 109891.

motor phase sequence to be phase 3, phase 2 and then phase 1. Note that in the sequence given in Figure 4-4, although \overline{DR} is 0V, the first CP is not generated until the previous left drive is completed, i.e., SS3 has timed out.

The reader may be operated by applying step pulses as described in Section 3.4.2 instead of a continuous drive signal. See Figure 4-4, the right half section. In this mode of operation, the reader is under control of step pulses only and one pulse must be present for each line. Operation of the card using step pulse inputs is identical to that just described for continuous drive signals except that each CP is generated from each new step pulse. The pulse width must be wide enough so that the DRV line signal can generate the CP signal (approximately 1 us). In addition, it must not be so wide that it is still present when the feed hole goes on character or else it may drive one more character.

4.2.4.2 Synthetic Feed Hole and Data Circuitry

Flip-flops FF3 and FF4 and gate Z7 are used to generate a synthetic feed hole (SFH). This output is identical to the FH signal but free from any noise or oscillation which may be present in the true FH signal as it goes on character at the end of each step. Both FF3 and FF4 are set at approximately the same time: FF3 by \overline{SSI} and FF4 are set at approximately the same time: FF3 by \overline{SSI} and FF4 by \overline{CP} . See Figure 4-5. Outputs FF3 and $\overline{FF4}$ are then combined at pins 9 and 10 of NAND gate Z7 and inverted at Z6, pin 10 to produce \overline{SFH} which, in turn, is again inverted by Z6 pin 12 (mode 5 output) to give SFH. In mode 6, SFH is generated directly from Z7, pin 8 and inverted at Z6, pin 12. FF3 and FF4 are set (FF3 output is +5V and $\overline{FF4}$ is 0V) at the beginning of each CP (FF3 by \overline{SSI} and FF4 by \overline{CP}) resulting in SFH being high. As the tape advances, the feed hole goes off character causing \overline{FH} to go high and to reset FF4. $\overline{FF4}$ is now +5V causing SFH to be 0V which follows FH. When FH goes back on character, FF3 is reset placing FF3 at 0V and returning SFH to +5V. SFH remains at +5V until the next stepping sequence is repeated and FH again goes off character. If through jitter or noise FH goes off and on character, SFH will not see it since FF3 and $\overline{FF4}$ are locked up until the next sequence.

Latches Z1 and Z11 are used to synthesize the data output so that they too are free from jitter, especially during High Speed mode. The track outputs are unlatched when \overline{SFH} is +5V (FH off character) and follow the cell outputs. When FH is true (on character) \overline{SFH} goes to 0V and latches the data. Since SFH does not switch until another CP signal is generated, the data outputs will remain fixed, regardless of any tape

jitter. This arrangement also allows the data to envelope the sprocket by at least 100 us on both the rise and fall sides.

4.2.4.3 High Speed Mode Operation

High speed operation (300 char/sec) is accomplished by disabling the motor damping pulse, allowing the motor to accelerate more rapidly. A 0 volt level on the $\overline{\text{HI SPD}}$ line disables SS2 (and SS3 which is triggered by SS2) and enables SS5. Refer to Figure 4-6.

The period of SS1 is shortened due to R7 being removed since CR3 is back biased (Z7, pin 3 in high speed mode is +5V). Thus the RRDY signal at Z16, pin 3 is dependent only on the DRDY line and the 100 us delay provided by $\overline{\text{SS4}}$. The first CP generated after the application of the drive signal, however, is still generated by the DRV line as described in Section 4.2.4.1. Therefore in High Speed operation, the reader drives tape at the maximum rate allowed by the characteristics of the stepper motor (in excess of 300 characters/sec) and not the predetermined 200 characters/second as set by SS1 and SS3.

One other important difference is the inhibiting of SS2 which is used to eliminate the stepper motor oscillation as the tape comes on character. At 300 characters, if the reader remains in drive (DRV line true), this is not significant since the motor starts driving again as soon as it reaches the next character (except for the relatively small 100 us delay of SS4). If the drive signal is removed and then re-applied within 100 us after the leading edge of the sprocket, no problem will occur. However, if the drive signal were removed and then reapplied when a second feed hole is read, a double reading would occur. To prevent this, SS5 is used to lock out all drive signals for approximately 25 ± 5 ms until the tape has settled out.

Referring to Figure 4-6, when a drive command is removed, SS5 is enabled by the negative going DRV signal. The next drive signal will generate a new CP at the end of SS4 provided it is applied within 100 us after the leading edge of the sprocket (before SS4 times out). If the drive signal is not applied and SS4 times out, SS5 is triggered and the $\overline{\text{SS5}}$ signal drops to 0V for 25 ± 5 ms and holds the $\overline{\text{CPG}}$ signal at +5V. Thus all drive commands are locked out until the tape has settled. This, of course, has no effect on the data outputs since they are latched (see Section 4.2.4.2). When SS5 times out and $\overline{\text{SS5}}$ goes to +5V, a new drive sequence can be started.

4.2.4.4 Power Turn-On and Load

Flip-flops FF3 and FF4 are reset by one of the following conditions: (1) when power is first turned on or (2) when the LOAD switch is actuated. When power is first turned on, pin 9 of Z16 is at 0V causing pin 8 of Z16 to be 0V which resets the flip-flops. When C10 charges (approximately 50 milliseconds) to +5V, pin 8 of Z16 will go high providing the LOAD switch is not actuated. If the LOAD switch is actuated, pin 8 will remain at 0V until the $\overline{\text{LOAD}}$ signal is removed. If during initial turn-on, both Q outputs of FF1 and FF2 are at +5V (a prohibitive condition), pin 3 of Z2 inverts these outputs and resets the flip-flops.

4.2.5 READER MOTOR AMP CARD, 110011

Mounted on the inside of chassis is the Reader Motor Amplifier card. This card is used to amplify the $\emptyset 1$, $\emptyset 2$ and $\emptyset 3$ output from the 109891 Step Motor Driver card which is used to operate the stepper motor. See Figure 8-9 for schematic and assembly.

4.2.6 CHAD DETECTOR CARD 110291-1

The optional Chad Detector card is used to determine if the level of chad in the chad drawer is above a preset level. This level is detected by a lamp-photocell, DS4-Q4, arrangement. See Figure 8-1, 8-2 or 8-3 depending upon the model. The schematic of the Chad Detector card is shown in Figure 8-10. If the level of chad builds up so that Q4 shuts off, the base of Q1 on the Chad Detector card will go high, turning on Q1. This causes the latch composed of Z1, pins 4-10 to be set and places 0V at Z1-8. Z1-11, in turn, goes to +5V which turns on Q2 and the ERROR lite. Z1-11 also causes Z1-3 to go to 0V which is applied to the Control Logic and Feed Hole Driver Card producing a true Tape/Chad Error output (mode XX0 only). After the chad has been emptied, the latch is reset by depressing the Chad reset switch S9, located near the punch. This places 0V at Z1-9 causing the latch to reset.

4.3 RPM1075 PUNCH MECHANISM

The operation and maintenance of the RPM1075 Punch Mechanism is described in a separate manual. The RPM1075 consists of punch head, punch pin drive linkage, solenoids, incremental motor, capstan and pinch roller, tape guide and pathways. Three motor windings, L1, L2, and L3, control the movement of the tape and their energizing sequence determines the direction of movement. See the description of

the Direction Control Flip-Flops FF1 and FF2 in Section 4.2.1. The solenoids are operated from Q1-Q8 on the Data Logic and Driver card. See Section 4.2.2. Suppression diodes CR1-CR8 for the solenoids are mounted on the Data Logic and Driver Card. Chassis-mounted Zener diode Z1 is used to speed the suppression process. Each motor winding and solenoid is fused with a 2A, 250V fuse. These fuses are mounted on the side of the Punch Mechanism.

4.4 LIGHT SOURCE

A straight line filament lamp rated at 5.8 VDC @ 500 milliamps is used as the light source. It has been derated approximately 10% to provide a long life expectancy in excess of 13,000 hours. The lamp is mounted in a bracket which along with the lens is replaced in the event of a lamp failure. The light source assembly replacement is described in Section 6.11. The power supply voltage for the lamp is +5.40 and is adjusted as described in Section 5.6.3.

4.5 HYBRID READ HEAD ASSEMBLY

The read head assembly contains a complete photocell and amplifier assembly. The negative going on character photocell output from each track is amplified and brought to the output plug J1. The output of the read head amplifiers is 0V when no character is sensed and $> +2.4V$ when a hole is sensed. The output stage of each track is identical and is shown in Figure 2-2, Circuit C. A pair of test pins for the feed hole cell output is available for the adjustment procedures described in Section 5 and is located under the photoelectric sensor assembly. See Figure 5-2. A schematic of the test pin circuitry is given in Figure 8-11.

SECTION V

MAINTENANCE

5.1 GENERAL

The REMEX tape reader/perforator systems are designed to keep maintenance as simple and infrequent as possible. Table 5-1 lists the maintenance equipment required for the various procedures. To prolong the life of the equipment and minimize down-time, certain checks and preventive procedures are set up in Sections 5.2 and 5.3 and Table 5-2 with suggested schedules. Section 5.4 outlines possible malfunctions along with probable cause and remedies. The remaining sections describe the required adjustment procedures. Replacement procedures are given in Section 6.

Table 5-1. Maintenance Equipment Required

<u>Item</u>	<u>Quantity</u>
Extender Board, REMEX Part Number 109091	1
*Extractor Tool (for pin removal on Amp plastic connectors) Amp 454747-1	1
*Flexible Feeler Gauge, 0.010 to 0.011 inch or three pieces of 3.7 mil mylar tape stapled together	1
*Frequency Counter, 10 Hz to 10 MHz, 5V input	1
Miller-Stephenson MS-200 Magnetic Tape Head Cleaner (REMEX Part Number 716004-150)	1
*Pulse Generator, 10 Hz to 1 MHz, up to +5V amplitude, 1 μ s to 100 ms width	1
*Oil, non-detergent, SAE-10	-
*Oscilloscope, DC to 10 MHz, single sweep	1
Spring Scale, 1 lb.	1
*Voltmeter, Digital, 0-0.1 ma, 0-100 mV dc, 0-100V dc, 100K impedance or greater	1
REMEX Read Head Alignment Tool 109299	1

* Not available from REMEX.

5.2 PREVENTIVE MAINTENANCE, PERFORATOR SECTION

Preventive maintenance, which includes inspection, cleaning and lubrication, should be check periodically in order to maintain peak performance. In addition, in order that the warranty remain in effect, the unit must be maintained in accordance with

the instructions outlined below (see Section 1.3 and page iii). A preventive maintenance schedule and log are presented in Table 5-2 which indicates the item, frequency of action, and references the maintenance paragraph. For customer convenience the table is arranged so that a log can be kept of when each maintenance procedure was performed. Periodic service is determined by the number of rolls of tape punched (1000 ft. rolls). See Section 5.3 for preventive maintenance of the reader section.

NOTE

The frequency of service as listed in Table 5-2 has been adopted for clean environmental conditions and usage. These intervals, however, may vary from one installation to another. The punching of oiled paper tapes may increase the frequency of service. See the note in Section 5.2.1.

Table 5-2 gives the Preventive Maintenance Schedule for only the tape supply and take-up portion of the perforator system. Preventive maintenance and adjustment procedures for the RPM1075 Punch are given in REMEX Technical Manual for the RPM1075 Punch and must also be followed.

5.2.1 50 ROLL SERVICE

Preventive maintenance after every fifty (50) rolls of tape consists of dust removal from the punch, a functional check and lubrication when used with certain types of tape. See the REMEX Technical Manual for the RPM1075 Punch for details.

NOTE

When punching oiled paper tapes, more frequent dust removal is necessary since the dust and oil mixture will tend to adhere to the punch capstan and affect registration. Also remove oil accumulated from capstan and pinch roller with alcohol on cloth. Don't get alcohol on bearings or pins.

5.2.1.1 Functional Check

The following items should be checked for the proper operation after every 50 rolls of tape:

- a. Check each of the front panel control switches to see that they perform the functions outlined in Table 3-2.
- b. Check the Tape Handling Error signal at J1-20, to make sure it is in its true state for those conditions listed in Table 3-1.

Table 5-2. Preventive Maintenance Schedule and Log, Perforator Section

Frequency, Rolls of Tape	Date	Initial	Frequency, Rolls of Tape	Date	Initial	5.2.1		500 Roll Service										2000 Roll Service	
						5.2.1	5.2.1.1	5.2.2.1	5.2.2.2	5.2.2.3	5.2.2.4	5.2.2.5.1	5.2.2.5.2	5.2.2.5.3	5.2.2.5.4	5.2.3.1 and 5.2.3.2			
50			1050			X	X												
100			1100			X	X												
150			1150			X	X												
200			1200			X	X												
250			1250			X	X												
300			1300			X	X												
350			1350			X	X												
400			1400			X	X												
450			1450			X	X												
500			1500			X	X	X	X	X	X	X	X	X	X	X	X		
550			1550			X	X												
600			1600			X	X												
650			1650			X	X												
700			1700			X	X												
750			1750			X	X												
800			1800			X	X												
850			1850			X	X												
900			1900			X	X												
950			1950			X	X												
1000						X	X	X	X	X	X	X	X	X	X	X	X		
			2000			X	X	X	X	X	X	X	X	X	X	X		X	

- c. Check to see that the voltage across R1 (mounted on the chassis near the transformer) is between 7.5 and 9 volts when one of the punch motor windings is energized. An oscilloscope should be used for this.
- d. Check each data line to verify that the appropriate track is punched when the data input line is in the true condition as described in Section 3.3.3.
- e. Verify the proper operation of Asynchronous Reverse Operation as described in Section 3.3.4.
- f. Verify the presence of the Punch Ready and System Ready outputs as described in Table 3-1.
- g. Check for proper hole registration as shown in Figure 1-6.

5.2.2 500 ROLL SERVICE

Preventive maintenance after every 500 rolls of tape consists of those items outlined in Section 5.2.1 and those items called out after 500 rolls in the REMEX Technical Manual for the RPM1075 Punch manual. In addition, a check of those items listed in Section 5.2.2.1 through 5.2.2.5 is required.

5.2.2.1 Supply Platter Brake Wear (RAB and RDB Units Only)

Check the condition of the supply platter brake. If the wear has become excessive, such that even contact is not made with the platter, replace the brake as described in Section 6.7.

5.2.2.2 Bearing Checks (RAB and RDB Units Only)

The bearings in the following areas should be checked and replaced if required:

- a. Supply Platter
- b. Tape Low Sensor Arm
- c. Tape Guide Rollers
- d. Supply Arm

5.2.2.3 Control Logic

Check the adjustments on the Control Logic and Feed Hole Driver card as described in Section 5.5.2. Line voltage should be set at nominal value for the voltage being used; not the $\pm 10\%$ tolerance levels.

5.2.2.4 Power Supply Voltages (Perforator Section)

Measure and record all voltages listed below with a voltmeter. A change in voltage may be indicative of a gradual component failure. Before taking any measurements, allow a short period of time for warm up after turning on power. The +24V measurement should be made while punching all holes. The +5.00 VDC is adjusted as described in Section 5.5.3 and the +5.40 VDC is adjusted as described in Section 5.6.3. See Section 5.3.3 for reader section voltages. All voltages given are with ac at nominal value for the voltage being used; not the $\pm 10\%$ tolerance levels.

<u>Voltage</u>	<u>Card</u>	<u>Measure</u>		<u>Pot</u>
		<u>From</u>	<u>To</u>	<u>Adjustment</u>
+5.00 \pm 0.05 VDC	Step Motor Power Supply	TP3	TP4	R6
+24 VDC \pm 3V		BRI + Terminal	TB2-1	-

5.2.2.5 Supply Deck Checks (RAB and RDB Units Only)

Sections 5.2.2.5.1 through 5.2.2.5.4 describe the areas of the supply deck which should be checked after every 500 rolls of tape.

5.2.2.5.1 Tape Tension Arm

Measure the tension on the supply take-up arm. With the arm at the center of its travel area (brake release point), the tension on the arm should be 3.00 ± 0.25 oz. when measured at the tape roller. If this is not the case, perform Section 5.5.5.1.

5.2.2.5.2 Tape Low Switch Actuation

Measure the distance from the inside edge of the tape low sensing arm to the hub at the point S8 is actuated. This distance should be $5/16"$. If this is not the case, perform Section 5.5.5.2.

5.2.2.5.3 Supply Brake

Measure the distance of the tape tension arm from its rest position when the brake contacts the rim of the supply platter. This distance should be $2-3/4 \pm 1/4$ inches. If this is not the case, perform Section 5.5.5.3.

5.2.2.5.4 Supply Error Switch, S7

Check Supply Error Switch, S7, for proper actuation by the tape tension arm at both ends of its travel. If the switch is not actuated as described, perform Section 5.5.5.4.

5.2.3 2000 ROLL SERVICE

Preventive maintenance after 2000 rolls of tape consists of those items outlined in Sections 5.2.1 and 5.2.2 and those items listed in the REMEX Technical Manual for the RPM1075 Punch manual for 2000 rolls of tape. In addition, a check of those items listed in Section 5.2.3.1 and 5.2.3.2 should also be made.

5.2.3.1 Parts Check

The operation of the following items should be checked and replaced if not functioning properly:

- a. Supply Platter Linkage
- b. Supply Platter Brake
- c. Supply Hub Springs

5.2.3.2 Moveable Parts

Remove, clean and check all moveable parts, shafts and bearing sleeves. Re-assemble and lubricate all contacting surfaces with SAE-10 non-detergent oil.

5.3 PREVENTIVE MAINTENANCE, READER SECTION

Preventive maintenance, which includes cleaning and lubrication, should be checked periodically in order to maintain peak performance. In addition, in order that the warranty remain in effect, the unit must be maintained in accordance with the instructions outlined below (see Section 1.3 and page iii). A preventive maintenance schedule and log are presented in Table 5-3 which indicates the item, frequency of action and references the maintenance paragraph in this section. For customer convenience, the table is arranged so that a log can be kept of when each maintenance procedure was performed. Also refer to Section 3.6, Operational Maintenance.

NOTE

The frequency of cleaning as listed in Table 5-3 has been adopted for clean environmental conditions and usage. These times, however, may vary greatly from one installation to another. For example, a reader used in a machine shop to program numerical controls may require maintenance procedures considerably more frequently.

5.3.1

CLEANING

CAUTION

In all cleaning procedures, avoid using cleaning methods and materials other than those recommended in this manual. Certain cleaning compounds will damage parts of the reader, especially in the readout assembly area. REMEX primarily recommends the use of Miller-Stephenson MS-200 Magnetic Tape Head Cleaner (REMEX Part No. 716004-150) for most areas requiring cleaning. However, due to the degreasing nature of the cleaner, it should not be used in areas where the spray may come in contact with bearings or other oiled parts. This cleaner may be obtained from REMEX or directly from Miller-Stephenson Chemical Company at one of the following locations:

1001 East First Street 1350 West Fullerton Avenue
Los Angeles, California 90012 Chicago, Illinois 60614

Route 7
Danbury, Connecticut 06810

To use the cleaner, hold the spray can 4 to 6 inches from the area to be cleaned and allow spray to flush the dirt off. If a heavy buildup is present, loosen with the spray mist and scrub with a cotton swab. A 6-inch pin-point, spray nozzle extension is available for hard-to-reach areas or for delicate applications. Avoid spraying on lubricated surfaces or parts.

If the Miller-Stephenson cleaner is not available, a small amount of isopropyl alcohol applied to a clean, lint-free cloth or cotton swab may also be used. However, it should be used carefully and sparingly since damage to the photocell and the finish on the plastic covers may result. Use only clear, unadulterated isopropyl alcohol. Do not use ethyl alcohol or denatured alcohol as the denaturing agents vary and may damage reader.

It is important that, whether the MS-200 cleaner or the isopropyl alcohol is used, only the amount required to clean the surfaces be applied. Never saturate or drench the areas to be cleaned. Never apply these materials to the lamp assembly.

Table 5-3. Preventive Maintenance Schedule and Log, Reader Section

Frequency* of Action Weeks	Date	Initial	Frequency* of Action Weeks	Date	Initial	5.3.1.1	5.3.1.2	5.3.1.3	5.3.1.4	5.3.1.5	5.3.3	5.6.2	5.6.3	5.6.4	5.6.5
						Cleaning					Check Adjustments				
2			28			X	X	X	X						
4			30			X	X	X	X						
6			32			X	X	X	X						
8			34			X	X	X	X						
10			36			X	X	X	X						
12			38			X	X	X	X						
14			40			X	X	X	X		X	X	X	X	X
16			42			X	X	X	X						
18			44			X	X	X	X						
20			46			X	X	X	X						
22			48			X	X	X	X						
24			50			X	X	X	X						
26						X	X	X	X		X	X	X	X	X
			52			X	X	X	X	X	X	X	X	X	X

5.3.1.1 Read Head Assembly Cleaning

The top surface of the photoelectric sensor assembly and the area between the upper and lower tape guides should be cleaned every two weeks (for most installations having clean environments; dirtier environments which contain dust, oil and sprays, such as machining areas, may require cleaning as must as every eight hours). Cleaning is extremely important because any dirt or foreign material in this area can create errors in readout. Use the bristle brush supplied to clean the readout area of the photoelectric sensor. Use a small amount of the recommended cleaning solvents applied to a cotton swab if necessary. Care should be exercised so that no residue remains from the recommended cleaning materials when the cleaning operation is completed.

5.3.1.2 Lamp and Lens Cleaning

The lamp and lens should be checked for cleanliness every two weeks and cleaned as required. To clean the lamp assembly and lens, use only a soft cloth. Do not use the items described in the caution in Section 5.3.1. Remove the upper cover and carefully clean the lamp and lens. Care should be taken so that the adjustment of the lamp is not disturbed. If the lamp requires adjustment, refer to Section 5.6.2.

CAUTION

Some lenses are made of plastic and tend to scratch easily. Care should be exercised when cleaning the plastic lens. The reflective material on the lamp is easily damaged by strong solutions. Use care in cleaning this area.

5.3.1.3 Sprocket Cleaning

The sprocket wheel should be checked for cleanliness every two weeks. Depending upon tape conditions, accumulations may build up on the sprocket and be transferred to the sprocket holes in the tape which may cause readout errors. Use the recommended cleaning materials described in the caution in Section 5.3.1. Care should be taken so that the alignment of the sprocket wheel is not disturbed. If the sprocket wheel requires adjustment, refer to Section 5.6.2.

5.3.1.4 Tape Cleaning

Repeated handling and usage of the tape leads to a build up of grease, oil and dirt on the tape. When the build up becomes excessive, this material will become lodged in the tape transport areas and could cause tape reading errors. To prevent this, the tape should be thoroughly inspected every two weeks and cleaned as required.

5.3.1.5 General Cleaning

The entire reader should be cleaned every year. Use the following procedure:

- a. If necessary for a particular problem area, separate the front panel from the chassis (paragraph 6.4 or 6.5).
- b. Using the bristle brush supplied with the unit and/or compressed air, remove all dust and dirt from both assemblies, paying particular attention to all moving parts. Use the recommended materials described in the caution in Section 5.3.1 to remove any grease or other accumulations. When cleaning, use care not to damage components on the circuit boards.
- c. Reassemble the front panel to the chassis assembly.

5.3.2 LUBRICATION

All points of rotation on the reader have permanently lubricated bearings and should not require lubrication for the life of the part.

5.3.3 POWER SUPPLY VOLTAGES, READER SECTION

Check all voltages listed below with a voltmeter once every three months. A change in voltage may be indicative of a gradual component failure. Before taking any measurements, allow a short period of time for warm up after turning on power. See Section 5.2.2.4 for perforator section voltages. All voltages given are at nominal ac line being used; not the $\pm 10\%$ tolerance levels.

<u>Voltage and Tolerance</u>	<u>Card</u>	<u>Measure</u>		<u>Pot</u>
		<u>From</u>	<u>To</u>	<u>Adjustment</u>
+31 VDC \pm 15%	Step Motor Power Supply	TP1	TP4	None
+5.00 VDC \pm 0.05 VDC	Step Motor Power Supply	TP3	TP4	R6
+5.40 VDC \pm 0.05 VDC	Step Motor Power Supply	TP2	TP4	R4

Note: Adjust for +5.00 VDC voltage and then Lamp Voltage (+5.40 VDC).

Trouble shooting is presented in the form of a chart, Table 5-4, which should be consulted whenever the performance of the perforator system is unsatisfactory. The chart is divided into three columns: Indication - the way in which the malfunction became evident, Probable Cause - the possible reason or reasons for the malfunction, and Remedy - the manner in which the malfunction may be corrected.

NOTE

When disconnecting the plastic connectors, it is necessary to depress the two guide interlocks on each side of the receptacle before separating.

These procedures assume that the proper input signals are being applied and that all connectors are properly mated and functioning. In the event pins need to be removed from the Amp connectors, an extractor tool, Amp 454747-1 is available from Amp.

Table 5-4. Trouble Shooting Chart

Indication	Probable Cause	Remedy
1. Tape does not feed nor punch.	1. AC power not present.	1. Check to see if ac power cord is plugged in at both ends.
	2. Fuse F1 faulty.	1. Check fuse F1 and replace if blown.
	3. Switch S1 faulty.	1. Check switch S1 and replace if faulty.
	4. Tape/Chad Error present.	1. Check for presence of tape/chad error at J1, pin 20. If present, correct supply error.
	5. +24V not present.	1. Check for presence of +24 VDC at red terminals of BR1. If not present, check for 24 VAC at yellow terminals. If not present, replace T1. If present at yellow terminals, replace BR1.
		2. Check for proper operation of Z1 on chassis and replace if defective.
6. +5V not present or not properly adjusted.	1. Check for presence of +5 VDC at pin 16 on step motor power supply card. Readjust as described in Section 5.5.3. If not present, check for 22 VRMS at pins 3 and 4. If ac is not present at pins 3 and 4, replace T1. If ac is present, replace step motor power supply card.	
2. Tape punches but does not feed.	1. Control Logic and Feed Hole Driver card faulty.	1. Check operation of card for presence and proper sequencing of L1, L2, and L3 outputs. Replace card if outputs are not correct.
	2. R1 faulty.	1. Check R1 on chassis and replace as required.
	3. Q1, Q2, or Q3 faulty.	1. Check Q1-Q3 on chassis and replace as required.

Table 5-4. Trouble Shooting Chart (Continued)

Indication	Probable Cause	Remedy
2. Tape punches but does not feed. (Cont'd)	4. Faulty Punch Step Motor.	1. Check mechanism per RPM1075 manual.
	5. Blown step motor fuse(s).	1. Check mechanism fuses.
3. Tape feeds but does not punch data holes.	1. Data Input signals not present at input or improperly timed.	1. Check to see that data inputs are present and of correct timing. See Section 3.3.3.
	2. Control Logic and Feed Hole Driver card faulty; no Punch Clock signal.	1. Check TP2 on Data Logic and Driver card for positive going Punch Clock signal. If not present, replace Control Logic and Feed Hole Driver card.
	3. Data Logic card faulty. Faulty punch solenoids or fuses.	1. Check proper operation of Data Logic card.
4. No feed holes being punched. Data holes ok.	1. Control Logic and Feed Hole Driver card faulty.	1. Check for presence of Feed Hole Solenoid output at pin 2 on Control Logic and Feed Hole Driver card. Replace card if output is not present.
	2. Q2 or CR12 faulty.	1. Q2 or CR12 on Control Logic and Feed Hole Driver Card for proper operation and replace if faulty.
	3. Punch Solenoid or fuse faulty.	1. Check feed hole solenoid on punch and replace if faulty. Refer to Punch Mechanism Manual.

Table 5-4. Trouble Shooting Chart (Continued)

Indication	Probable Cause	Remedy
5. One data track not being punched when true input signal is present.	1. Data Logic and Driver card faulty.	1. Check associated output on Data Logic and Driver card for OV true signal when Data and Data Clock are present. If output not present, replace card.
	2. Punch Solenoid or fuse faulty.	1. Check appropriate solenoid on punch and replace if faulty.
	3. Card connector contacts dirty.	1. Clean connector contact.
6. Punched holes incomplete or ragged.	1. Timing improperly adjusted.	1. Adjust control logic timing as described in Section 5.5.2.
7. Supply reel unwinds too much tape; Supply switch actuates (RAB or RDB units).	1. Brake linkage improperly adjusted.	1. Adjust brake linkage as described in Section 5.5.5.3.
	2. Tape tension arm misadjusted.	1. Adjust tension on tape tension arm as described in Section 5.5.5.1.
	3. Brake block worn.	1. Check condition of brake block and replace if worn as described in Section 6.7.
8. No low tape indication when tape supply is low.	1. Low tape light burned out.	1. Check low tape lamp and replace if burned out.
	2. Tape Low Switch Actuator misadjusted.	1. Adjust Tape Low Switch Actuator as described in Section 5.5.5.2.
	3. Switch S8 faulty.	1. Check S8 for proper operation and replace if faulty.

Table 5-4. Trouble Shooting Chart (Continued)

Indication	Probable Cause	Remedy
<p>9. Tape FEED/DELETE Switch, S5, depressed; tape does not feed.</p>	<p>1. Switch S5 faulty.</p>	<p>1. Check switch S5 for proper operation and the presence of 0V at J13, pin 6, when switch is in FEED position or 0V at J13, pin 5 when switch is DELETE position.</p>
	<p>2. Control Logic and Feed Hole Driver card faulty.</p>	<p>1. Check operation of Z2 on card and replace if faulty.</p>
<p>10. Tape FEED/DELETE Switch, S5, in FEED position, tape feeds, data tracks not inhibited.</p>	<p>1. 0V not present at Data Logic and Driver card.</p>	<p>1. Check for presence of 0V at pin D of J12. If present, replace Data Logic and Driver card.</p>
<p>11. Same data line repunched on next line with new data present at input.</p>	<p>1. Control Logic and Feed Hole Driver card faulty.</p>	<p>1. Check for presence of positive going Data Clock signal at TP1 on the Data Logic and Driver card. If not present, replace Control Logic and Feed Hole Driver card.</p>
	<p>2. Data Logic and Driver card faulty.</p>	<p>1. If data clock signal is present at TP1 on the Data Logic and Driver card, replace that card.</p>
<p>12. Punch advances tape in one direction only.</p>	<p>1. Input Signal not present.</p>	<p>1. Check for presence of proper input signal as listed in Table 3-1.</p>
	<p>2. Control Logic and Feed Hole Driver card faulty.</p>	<p>1. If proper input is present, replace Control Logic and Feed Hole Driver card.</p>

Table 5-4. Trouble Shooting Chart (Continued)

Indication	Probable Cause	Remedy
13. Wrong data being punched (more than one hole).	1. Data Logic and Driver card faulty.	1. Check for proper inputs at J1, pins 1-8. If correct inputs are present, replace Data Logic and Driver card.
	2. Data inputs not stable before Punch Command is issued.	1. Check operating instructions, Sections 3.3.3 and 3.3.4.
14. Holes being punched instead of no holes and no holes punched where holes are required.	1. Input mode not compatible.	1. Check inputs to see if they conform to the input mode of the unit (see Table 3-1).
		2. If inputs are correct, check Data Logic and Driver card for -5 and -6 mode operation. See Table 7-2. If wrong dash number, replace card or remove jumper (mode 5) or install jumper (mode 6). See Figure 7-14.
15. Short registration or double punching.	1. Punch mechanism faulty.	1. Check trouble shooting chart in punch manual.
	2. Excessive supply tension.	1. Check adjustment in Section 5.5.5.1.
	3. Incorrect control logic timing.	1. Check adjustments in Section 5.5.2.
	4. Run-Load lever holding pinch roller off capstan in punch mechanism.	1. Check for proper operation of RUN-LOAD lever.
	5. Punch pins sticking.	1. Lubricate punch per instructions in the RPM1075 manual.

Table 5-4. Trouble Shooting Chart (Continued)

Indication	Probable Cause	Remedy
16. No track outputs on any track, Reader section.	1. Read head dirty.	1. Clean read head assembly as described in Section 5.3.1.1.
	2. Illumination system misalignment.	1. Check illumination system alignment as described in Section 5.6.2.
	3. +5V not present at read head or read head malfunction.	1. Check for +5V at pins 11 and 12 of J6. If not present, check power supply card for proper operation. If present, replace the photoelectric sensor assembly as described in Section 6.10.
17. Output present on all but one track, Reader section.	1. Read head dirty.	1. Clean read head assembly as described in Section 5.3.1.1.
	2. Read head malfunction.	1. Replace read head assembly as described in Section 6.10.
18. One track output at reduced level or intermittent, Reader section.	1. Read head dirty.	1. Clean read head assembly as described in Section 5.3.1.1.
	2. Read head malfunction.	1. Replace the read head assembly as described in Section 6.10.
19. One track output too narrow or wide, Reader section.	1. Read head dirty.	1. Clean read head assembly as described in Section 5.3.1.1.
	2. Tape holes out of specification.	1. Check tape to see that it conforms to the specification described in Section 3.8.
20. Track output present with no hole punched in tape, Reader section.	1. Tape transmissivity too high.	1. Tape must have transmissivity of 57% or less as specified in Table 1-2.
	2. Read head malfunction.	1. Replace the read head assembly as described in Section 6.10.

Table 5-4. Trouble Shooting Chart (Continued)

Indication	Probable Cause	Remedy
21. LOAD switch in deactivated position, POWER switch in ON, correct drive signals present, tape does not move, Reader section.	1. POWER switch, S1 defective.	1. Check switch S1 and replace if defective.
	2. Light source improperly aligned.	1. Check illumination system alignment as described in section 5.6.2.
	3. Sprocket wheel improperly aligned.	1. Adjust sprocket as described in Section 5.6.2.
	4. Defective Step Motor Driver card.	1. Check operation of step motor driver card. Replace with spare if available.
	5. Step Motor defective.	1. Check output of step motor driver card to see if outputs are present. If so, replace stepper motor.
	6. LOAD switch, S4, defective.	1. Check switch S4 and make sure 0V is not present on the <u>LOAD</u> line.
22. Tape does not stop on character or bounces on and off character, Reader section.	1. Anti-Jitter Control not properly adjusted.	1. Adjust anti-jitter control as described in Section 5.6.4.
	2. Sprocket misaligned.	1. Adjust sprocket as described in Section 5.6.2.
	3. Step Motor Driver card faulty.	1. Check card for proper operation and replace if faulty.
23. POWER switch in ON position, lamp does not turn on, no dc voltages, Reader section.	1. No ac power.	1. Make sure ac power cord is plugged into ac source.
	2. Fuse F1 blown.	1. Check fuse and replace if required.

Table 5-4. Trouble Shooting Chart (Continued)

Indication	Probable Cause	Remedy
23. POWER switch in ON position, lamp does not turn on, no dc voltages, Reader section. (Cont'd)	3. POWER switch, S1, defective.	1. Check switch and replace if required.
	4. Step Motor Driver Power Supply card defective.	1. Check card and replace with spare if defective.
	5. T1 malfunctioned.	1. Check T1 and replace if faulty.
24. Tape speed not at 200 characters/second in asynchronous mode.	1. Reader speed misadjusted.	1. Adjust reader speed as described in Section 5.6.5.
25. Outputs jittery as tape stops on character.	1. Anti-Jitter Control misadjusted.	1. Adjust anti-jitter control as described in Section 5.6.4.
	2. Reader drive misadjusted.	1. Adjust reader drive as described in Section 5.6.2.
	3. Step Motor Driver card faulty.	1. Check card for proper operation and replace if faulty.
26. Irregular movement of tape.	1. Drive system improperly adjusted.	1. Check and adjust, if required, as described in Section 5.6.2.
	2. Sprocket wheel bent or worn.	1. Replace sprocket wheel as described in Section 6.12.
	3. Rear tape guide edge (front or rear) worn.	1. Replace appropriate tape guide.
27. Proper lamp voltage or +5V supply cannot be obtained. Other dc voltages ok.	1. Step Motor Driver Power Supply card malfunction.	1. Check card and replace if defective.

5.5 ADJUSTMENTS, PERFORATOR SECTION

5.5.1 GENERAL

Proper operation depends upon making and maintaining accurate adjustments. Although all adjustments are made at the factory, the following adjustments should be checked periodically (refer to Section 5.2 and Table 5-2) and should be performed when the perforator performance is unsatisfactory or when certain assemblies are replaced. Adjustments of the punch are covered in the REMEX Technical Manual for the RPM1075.

5.5.2 CONTROL LOGIC TIMING ADJUSTMENTS

The following single-shot adjustments on the Control Logic and Feed Hole Drive card control the punching cycle and are required any time the Control Logic and Feed Hole Driver Card or punch is replaced. This procedure is to be performed with a nominal line voltage of 115VAC or that voltage on which the transformer is set to run; not the 10% high or low tolerance. See Figure 5-1 for location of potentiometers and test points.

- a. Install a roll of tape (RAB units) or a box of fanfolded tape (RAF units) of the type to be used and thread it through the system. See Section 3.3.1.
- b. Place an oscilloscope probe at TP1 and the ground lead at TP4.
- c. Depress the DELETE switch and adjust R9 for a pulse width of 10.5 ± 0.2 msec. See Figure 4-3. Continue depressing the DELETE switch for steps d through f.
- d. Place the scope probe at TP2 and adjust R14 for a positive pulse width of 1.85 msec. See Figure 4-3.
- e. Place the scope probe at TP3 and adjust R10 for a negative pulse width of 2.5 ± 0.1 ms. See Figure 4-3.
- f. Continue punching approximately 50 feet with all holes after steps c through e have been performed.
- g. Examine the tape holes for poor punching (double punch, tearing holes, incomplete punch, etc.) and perform step h or i as required.
- h. If the holes are elongated, torn, or double punched, adjust R14 to decrease the pulse width at TP2. Do not go below 1.4 ms.
- i. If the holes are not being punched or are not being punched completely, adjust R14 to increase the pulse width at TP2. Do not go above 2.0 ms.

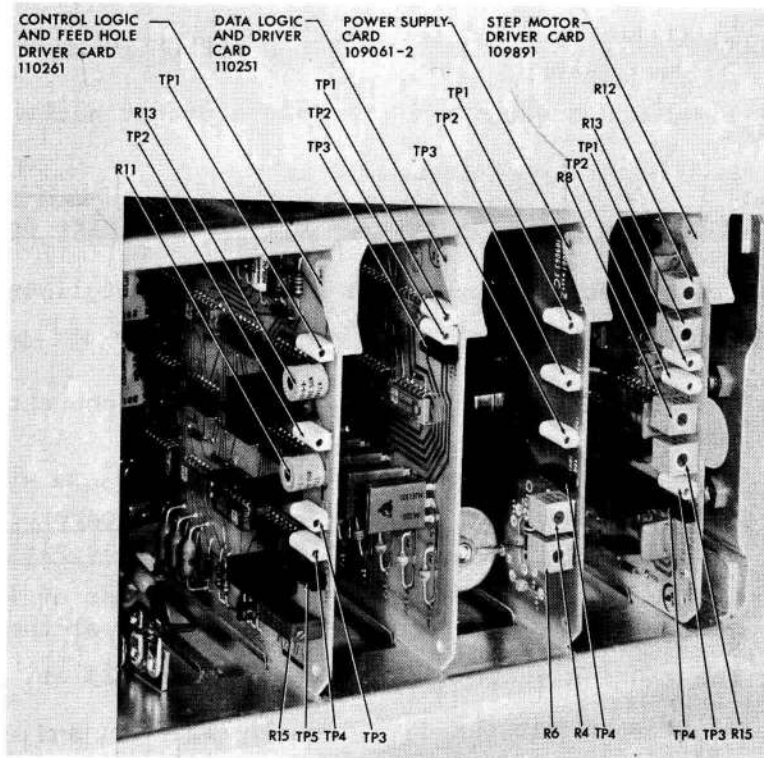

Figure 5-1. Location of Circuit Card Potentiometers and Test Points.

5.5.3 +5V POWER SUPPLY

The following procedure describes the adjustment of the +5V power supply:

- a. Place the POWER switch into the ON position.
- b. Place a digital voltmeter across TP3 and TP4 on the Step Motor Power Supply card.
- c. Adjust R6 until the meter reads $+5.00 \pm 0.05$ VDC.
- d. Remove the meter leads.

5.5.4 RUN-LOAD SWITCH

The adjustment of the RUN-LOAD switch, S6, when the lever is in the LOAD position is performed as follows:

- a. Remove all power from the punch system by disconnecting P1, P2 and P3.
- b. Place an ohmmeter across the NO and C contacts (bottom two contacts on each half of the switch).
- c. Place the RUN-LOAD lever in the LOAD position. The ohmmeter should read zero ohms (switch actuated). If it does not, loosen the nut which holds the actuator screw and rotate the actuator screw until the switch actuates. Tighten the lock nut.

5.5.5 SUPPLY DECK ADJUSTMENTS (RDB and RAB UNITS ONLY)

The following adjustments are required to insure proper mechanical operation of the supply deck.

5.5.5.1 Tape Tension Arm Adjustment (RDB and RAB Units Only)

The adjustment of the tape tension arm is performed as follows: All items in parenthesis refer to the items in Figure 5-2.

- a. Remove all power from the system by disconnecting P1, P2, and P3.
- b. Remove the set screw which holds the supply platter to the shaft. Remove the supply platter. Be careful not to lose the ball bearing in the shaft hole in the platter.
- c. Rotate the tape tension arm to the center of its travel arc and attach a spring gauge to the roller at the end of the arm.
- d. The tension gauge should read 3.00 ± 0.25 oz.
- e. If this is not the case, loosen nuts (A) and rotate screw (B) either in or out to achieve the reading specified in step d. Tighten nuts (B).
- f. Remove the gauge and replace the platter by performing the reverse of step b.

5.5.5.2 Tape Low Switch Actuator (RDB and RAB Units Only)

The adjustment of the tape low switch actuator is performed as follows. All items in parenthesis refer to the items in Figure 5-2.

- a. Remove all power from the system by disconnecting P1, P2, and P3.
- b. Remove any tape from the deck assembly.
- c. Place an ohmmeter across the NO and C contacts of switch S8.
- d. Move the low tape arm in toward the hub and note the distance at which the switch actuates (meter read zero ohms). This distance should be $5/16$ " from the hub.
- e. If it is not, loosen nut (C) and rotate screw (D) until S8 actuates at the distance specified in step d.
- f. Remove the ohmmeter.

5.5.5.3 Brake Linkage (RDB and RAB Units Only)

The following procedure describes the adjustment of the brake linkage. All items in parenthesis refer to items in Figure 5-2.

- a. Rotate the tape tension arm in toward its rest position to a distance of $2-3/4 \pm 1/4$ inches from its rest position. See Figure 5-2. At this point, the brake should come in contact with the platter.

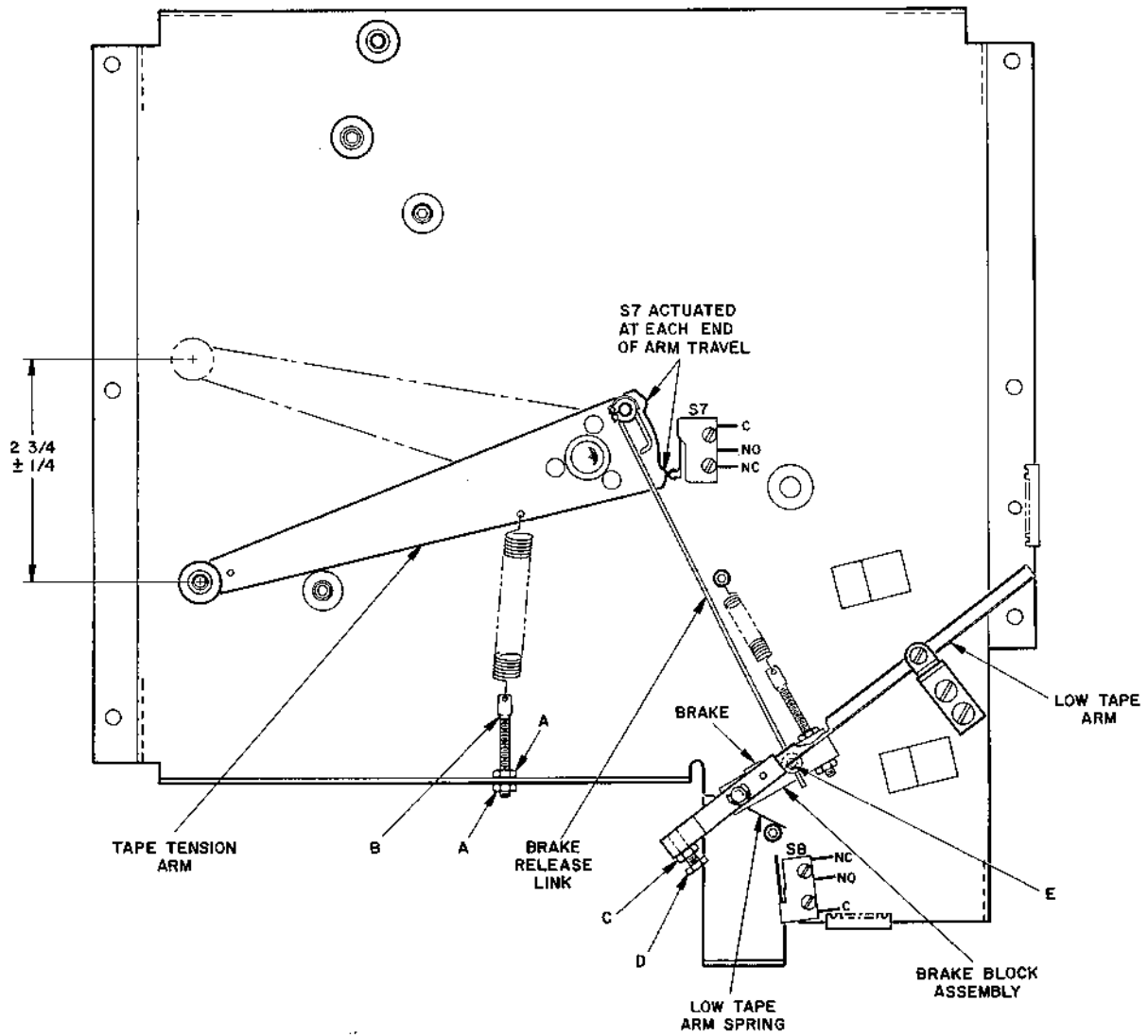

MMC 229

Figure 5-2. Supply Deck Adjustments.

5.5.5.4 Supply Error Switch, S7 (RDB and RAB Units Only)

The following procedure describes the adjustment of S7:

- a. Remove power from the unit by disconnecting P1, P2, and P3.
- b. Place an ohmmeter across the C and NC contacts on S7. The meter should read a closed circuit when the tape tension arm is in the center of its travel.
- c. Rotate the tape tension arm clockwise to the end of its travel. The meter should read open circuit.
- d. Rotate the tape tension arm counterclockwise to the end of its travel. The meter should read open circuit.
- e. If steps c and/or d are not as described, loosen S7 and adjust it until the conditions in steps c and d are satisfied. Tighten the screws.

5.6 READER ADJUSTMENT PROCEDURES

5.6.1 GENERAL

Proper operation depends upon making and maintaining accurate adjustments. Although all adjustments are made at the factory, the following adjustments should be checked periodically (refer to Table 5-3) and should be performed when the tape reader performance is unsatisfactory or when certain assemblies are replaced.

5.6.2 READER DRIVE SYSTEM AND LAMP ALIGNMENT

The following procedure describes the adjustment of the read head assembly, the light source assembly and sprocket wheel. This procedure assumes that the other adjustments in this section are correct. They have been cross referenced in this procedure in the event they too are required. All letters and numbers refer to items in Figure 5-3.

- a. Remove all power and control signals by disconnecting P1, P2, and P3 at the rear of the chassis.
- b. Remove the upper cover. See Section 6.9.
- c. Loosen two screws (A) and the lock nut on screw B. Adjust screw A to provide an approximate gap of 0.010 to 0.011 inch at gap A. This can be accomplished by using three pieces of 3.7 mil Mylar tape stapled together at the ends. Make sure the sprocket holes are exactly aligned for the three tapes. Move the tapes through the gap and adjust screws (A) until the tapes just move through without binding. Repeat using two pieces of tape which should move freely.
- d. Adjust screw (B) for an approximate gap of 0.011 inch between the curved surfaces of the upper and lower tape guides. Use the three pieces of stapled tapes which should just move through freely without binding.
- e. Make sure the lower edge of the sprocket wheel is positioned in the slot in the upper and lower guide as shown in Figure 5-4. The rim of the wheel should match the running surface of the upper guide allowing teeth B and C in Figure 5-4 to overlap line D but not allow the corners of the sprocket wheel to protrude beyond line A (upper guide). A minimum of three teeth must overlap line "D" either fully or partially. If this is not the case, loosen two screws (C, Figure 5-3) which hold the read head assembly mounting block to the front panel and move the read head assembly until this condition exists.
- f. Depress the LOAD switch.
- g. Reconnect P1, P2, and P3 and place the POWER switch in its ON position. The lamp should come on. Make sure the lamp voltage is $+5.40 \pm 0.05$ VDC. See Section 5.6.3, step c.

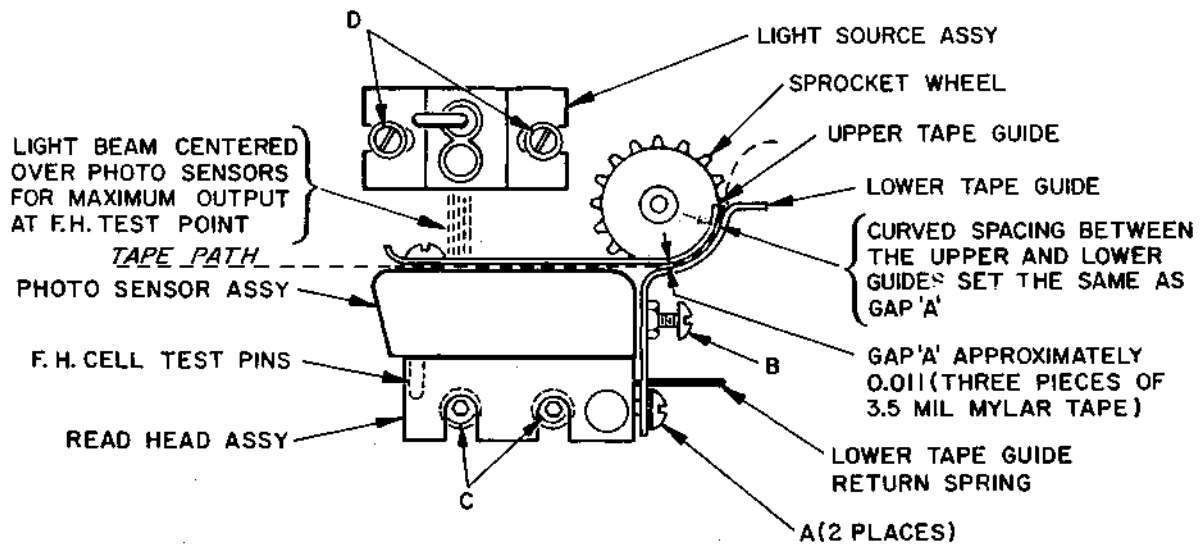
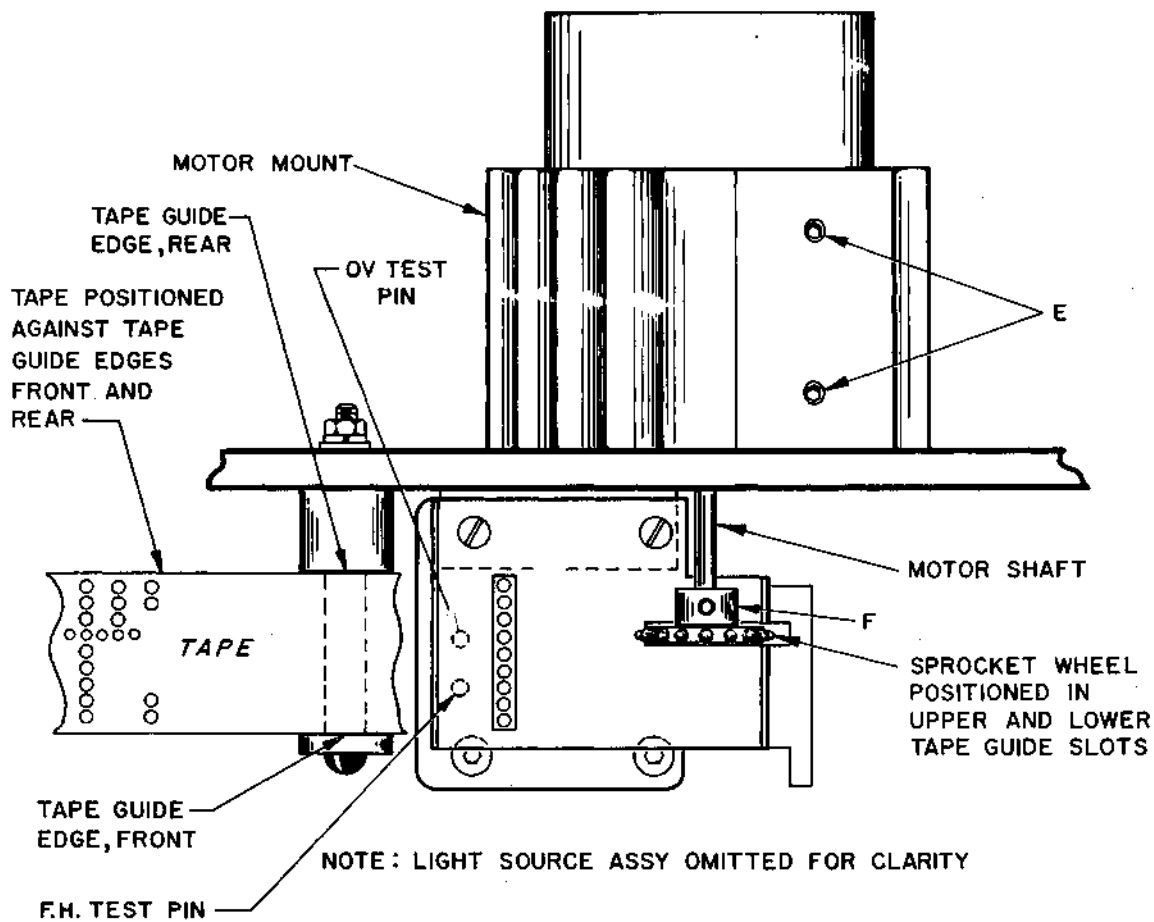

MMC 222

Figure 5-3. Reader Drive System and Lamp Alignment.

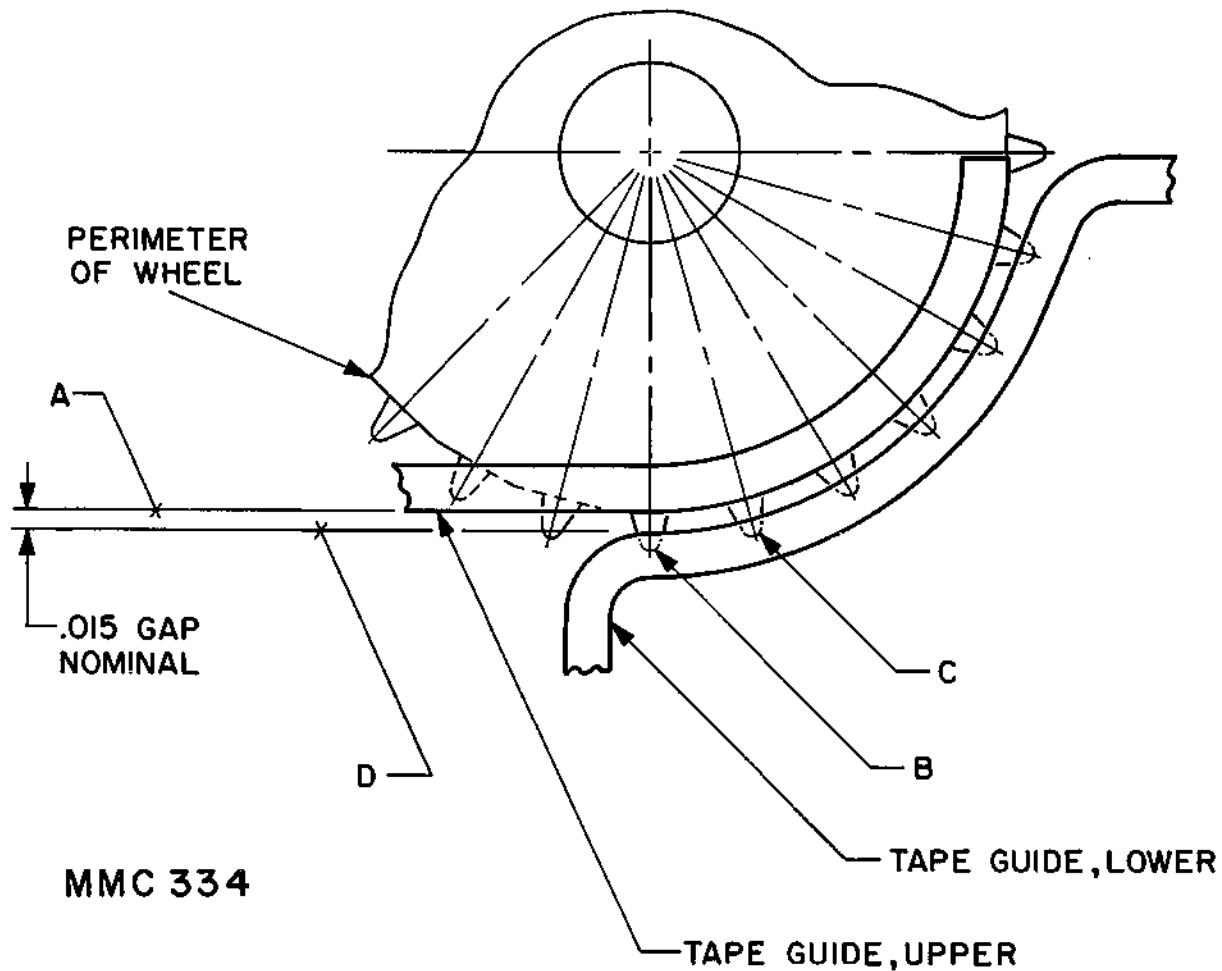

Figure 5-4. Setting of the Lower and Upper Tape Guides in Relation to the Sprocket

- h. Place a digital (or high impedance) voltmeter across the two test pins (FH cell out) located on the bottom side of the photoelectric sensor. Figure 8-11 shows the circuitry in the photoelectric sensor assembly associated with the FH test pins. The 0V test pin is the one nearest the panel; See Figure 5-3.
- i. Loosen the two screws (D) which hold the light source to the front panel and adjust the light source assembly as follows:
 - (1) Horizontally so that the light beam is centered over all nine photoelectric sensor readout holes and the reading on the voltmeter is at its absolute maximum (-0.20 VDC, min.; the feed hole output at test point is negative true when light is present).
 - (2) Adjust azimuth for alignment with the glass beads of the read head.

Tighten the screws carefully making sure the adjustment is not disturbed. Check the meter reading to be sure adjustment has not changed.
- j. Insert a loop of tape with holes punched in all tracks and known to be punched to the specifications described in Section 3.8 (a tape gauge is also available for this alignment, REMEX part number 109299). Make sure the tape (or gauge) is positioned against the front or rear tape guide edges and remains there during the next step.

- k. Loosen the two socket screws (F) which hold the sprocket to the motor shaft. Position the sprocket in or out so that the sprocket pins are centered in the sprocket holes in the tape (or gauge). Tighten the two socket screws.
- l. Loosen the socket screws (E) which hold the stepper motor to the heat sink. Rotate the motor so that the output reading on the meter is at its maximum (tape holes centered over readout cells). Tighten the set screws being careful not to disturb the setting of the sprocket. When rotating motor, use care not to disturb the in and out setting made in step k (the motor should set into the heat sink as far as it will go, i.e. up snug with the front panel).

WARNING

Use great care in handling the stepping motor since the case temperature may be very high, especially after running for a period of time. It is recommended that either the motor be allowed to cool or gloves be used in step l.

- m. Remove the meter leads and test tape.
- n. Perform the reverse of step b.

5.6.3 +5.40 LAMP VOLTAGE ADJUSTMENT

The lamp voltage is adjusted as follows:

- a. Place the POWER switch into its ON position.
- b. Perform Section 5.5.3 before performing this section.
- c. Place the leads of a voltmeter across TP2 (+5.40 VDC) and TP4 (OV) on the step motor power supply card.
- d. Adjust R4 on the step motor power supply card for a $+5.40 \pm 0.05$ VDC reading on the voltmeter.
- e. Remove the leads.
- f. Check the anti-jitter control adjustment. See Section 5.6.4
- g. Remove the voltmeter leads and test tape.

5.6.4 ANTI-JITTER CONTROL ADJUSTMENT

The anti-jitter control circuit is used to eliminate the jitter present in stepping motors when stepping from one character to the next. Before performing this procedure, make sure Sections 5.6.2 and 5.6.3 have been performed.

- a. Insert a loop of tape with all tracks punched and known to be punched as described in Section 3.8.
- b. Place the POWER switch into its on position and the LOAD switch in the off (run) position.

- c. Adjust R13 on the 109891 Step Motor Driver card fully clockwise (maximum speed).
- d. Connect a pulse generator to the \overline{DR} input, J3, pin 12. Set the pulse generator for 100 pps. See Section 3.4.2, Asynchronous Operation.
- e. Place the leads of an oscilloscope across TP1 ($\overline{SS2}$ output) and TP4 (OV) on the Step Motor Driver card. Trigger the scope on the negative going edge of the CP signal (TP2) on the step motor driver card.
- f. Start the pulse generator and observe the negative going edge of the $\overline{SS2}$ output (TP1) and adjust R8 until the interval from the negative going edge of CP to the negative going edge of $\overline{SS2}$ is 2.0 ± 0.1 msec.

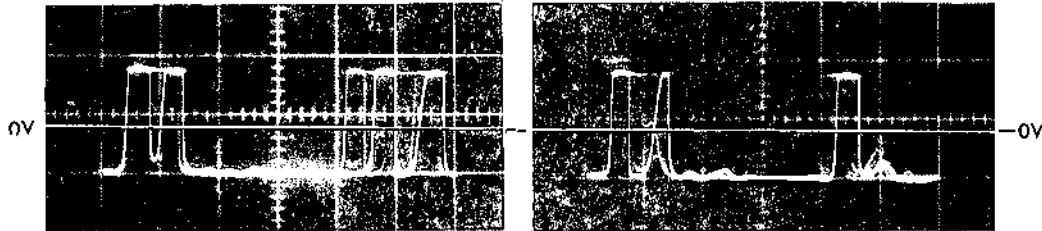

Two Examples of Anti-Jitter Control Misadjusted

SCALE: 0.5 V/CM, 5 MSEC/CM

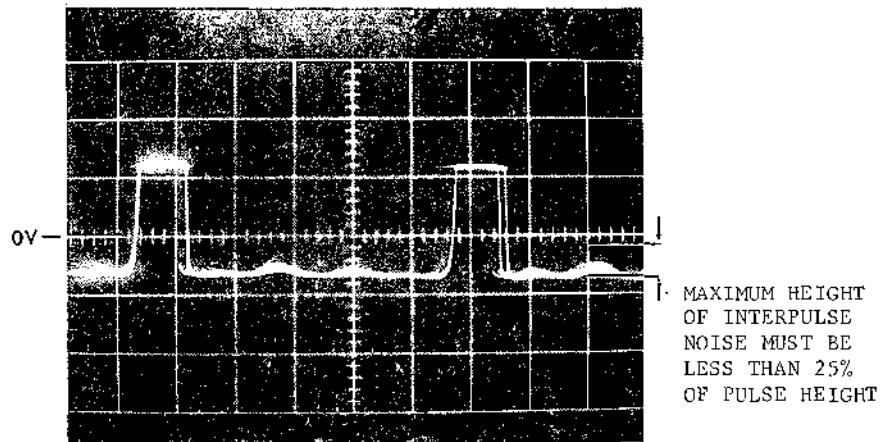

Anti-Jitter Control Properly Adjusted

SCALE: 0.5 V/CM, 2 MSEC/CM

MMC204A

Figure 5-5. FH Cell Test Pin Output During the Adjustment of the Anti-Jitter Control Circuitry.

- g. Place the leads of an oscilloscope across the FH cell output test pins located under the photoelectric sensor assembly (part of the read head assembly on the front panel). The OV test pin is nearest the panel; see Figure 5-3.
- h. Adjust R12 on the Step Motor Driver card until the ripple in the feed hole test point waveform disappears. The ripple is defined as amplitude variations in the -0.2 VDC level and not at the +0.6 VDC level nor the time jitter in the leading or trailing edges of the waveform. See Figure 5-5.
- i. Repeat step h but apply the pulse generator to the \overline{DL} input (pin 11 of J3).
- j. Turn off the pulse generator.
- k. Connect a pulse counter to the CP signal at TP2.
- l. Place the reader in high speed operation for drive left. See Section 3.4.3. Measure the speed by counting the CP signals per second.
- m. Repeat step l for drive right.
- n. If the speeds of steps l and m differ by more than 5% loosen the two socket screws (item E, Figure 5-3) which hold the motor to the heat sink. Rotate the motor slightly so that the difference in slew speeds is less than 5%. Repeat steps l, m and n as required. When rotating the motor, make sure it is kept tight to the panel so that the in and out position of the sprocket wheel is not disturbed. Also make sure the conditions of step m in Section 5.6.2 are maintained (i.e., with the tape stopped, the tape holes are centered over the photocells).
- o. Place the reader in Asynchronous Mode of operation using the pulse generator. See Section 3.4.2. Cycle the reader between 25 and 200 cps using step right pulses at J3, pin 12. Observe the FH cell test pins and readjust R12 such that at no step rate between 25 and 200 pps does the ripple at the feed hole test point exceed 25% of the total peak to peak waveform. See Figure 5-5.
- p. Repeat step o using step left pulses at J3, pin 11.
- q. Place the leads of an oscilloscope across TP3 (SS4 output) and TP4 (OV) and place the reader in asynchronous mode of operation using the pulse generator. Adjust R15 for a 100 ± 5 us positive pulse at TP3.
- r. Remove the test equipment and test tape.
- s. Perform Section 5.6.5

5.6.5 READER SPEED ADJUSTMENT

The speed of the reader should be adjusted to 210 ± 3 characters/second but not until Sections 5.6.2, 5.6.3 and 5.6.4 have been performed.

- a. Insert a loop of tape known to be punched as described in Section 3.7.
- b. Place the POWER switch into its on position.
- c. Place the LOAD switch in the off (run) position.
- d. Apply a drive right signal to pin 12 of J3.
- e. Connect a pulse counter to the FH cell test pins or to the feed hole output at J3, pin 9.
- f. Adjust R13 on Step Motor Driver card 109891 for a pulse repetition rate of 210 ± 3 pps. The reader is set at a speed slightly higher than 200 cps to allow it to function at a rate of 200 cps using step pulses. If operation with step pulses is not required, the reader may be set to 200 cps.
- g. See Text copy.

5.6.6 TAPE SPLICING

If tape breakage occurs, this break may result in damage to one, two, or possibly three characters. When splicing tape for this reader, great care should be used to ensure that the proper sprocket hole spacing be preserved. A lap splice should not be used; use only a butt type splice. To repair the tape without loss of characters, the process shown in Figure 5-6 is recommended and is accomplished as follows:

- a. Bring the tape ends together as shown in Figure 5-6A.
- b. Make a sketch of character(s) at the break (A-B-C) and five additional characters to the left (5-4-3-2-1) and five to the right (1-2-3-4-5) of the broken character(s) (A-B-C).
- c. Place the left end of the broken tape over a section of blank tape containing only feed holes so that at least eight or ten feed holes in each tape are aligned with one another as shown in Figure 5-6B. Cut the tapes at the third undamaged character to the left of damaged characters (A-B-C). Use care to insure that feed holes are aligned and make cut through the center of the holes in the third undamaged character. Characters 5, 4, and half of 3 should remain on the broken tape.
- d. Place the right end of the broken tape over the section of blank tape so that at least eight or ten feed holes are aligned with one another. Feed holes for one-half of 3, 2 and 1 on the blank tape cut in step c should be visible to the left of the broken tape end as shown in Figure 5-6C. Cut the tapes at the

third undamaged character to the right of the damaged character. Be sure that feed holes are aligned and make the cut through the center of the holes in the third undamaged character.

NOTE

One half of character 3 and characters 4 and 5 should remain in the broken tape.

- e. Place tape ends and new section on a flat surface with feed holes forward as shown in Figure 5-6 (tape is bottom side up). Using silver Scotch[®] tape, No. 852, splice the new section and the old tape ends as shown. That portion of tape that secures the old tape ends must cover the first two and a half characters (one-half of 3, 4, and 5) on the old tape ends. The edges of the tape should be between characters as shown. Use of 1/2-inch wide splicing tape is recommended as shown in Figure 5-6D.
- f. Repunch the characters recorded in step d.

[®]Registered Trademark of 3M Company

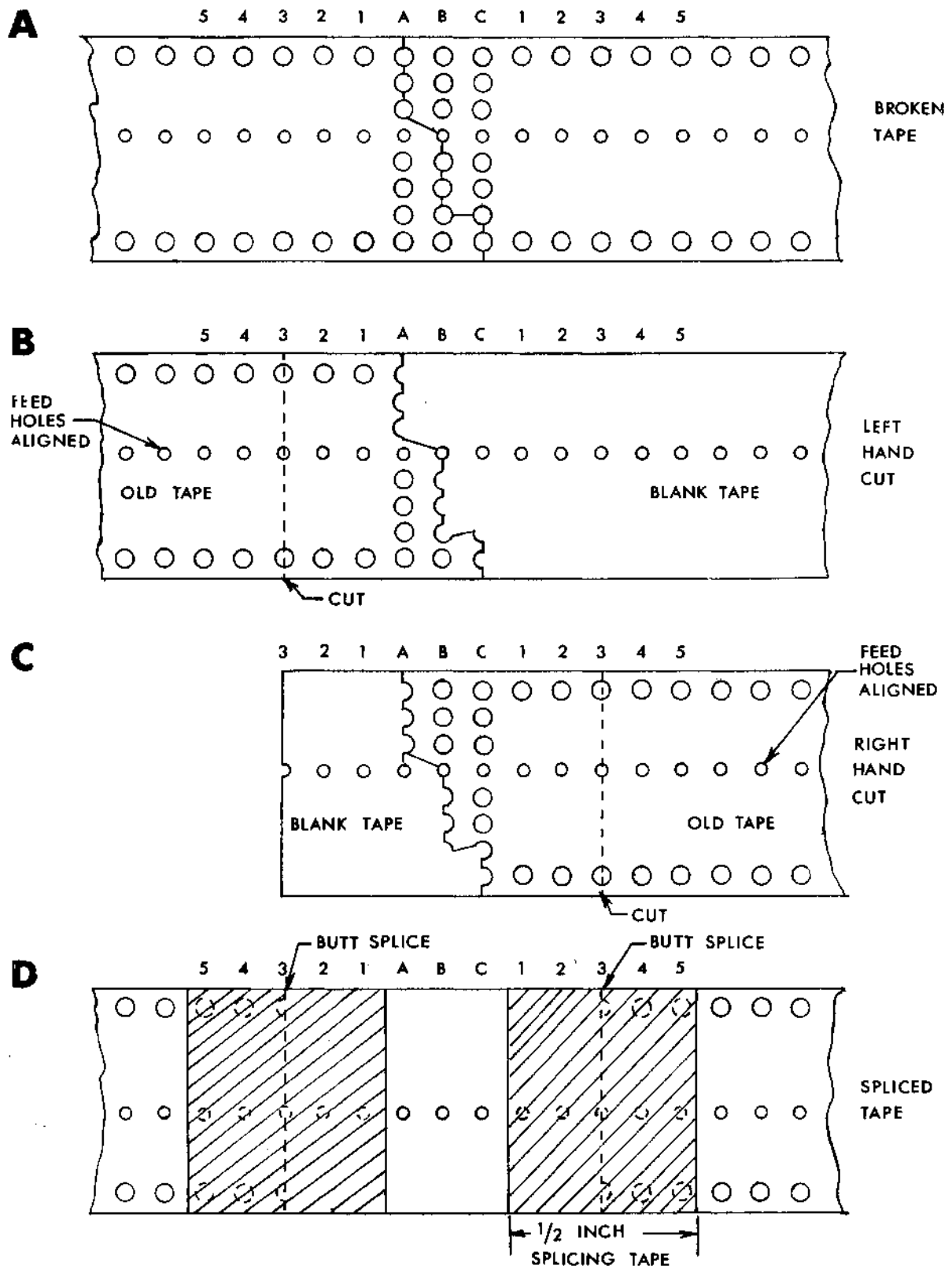

MMC 120A

Figure 5-6. Tape Splicing Procedure.

SECTION VI
PARTS REPLACEMENT

6.1 GENERAL

When any part of the punch system requires replacement or disassembly, the procedures outlined below should be followed closely. The warnings and cautions are included to protect personnel and equipment. Notes are included to assist persons unfamiliar with the equipment. Before attempting any procedure, all instructions for that disassembly should be read and understood.

6.2 PUNCH REMOVAL (RDB AND RAB UNITS ONLY)

The following procedure should be used when removing the punch. The letters in parenthesis refer to items in Figure 6-1.

- a. Remove all power and control signals from the unit by disconnecting P1, P2, and P3.
- b. Disconnect P9/J9.
- c. Loosen and remove screws (A) which hold the chad chute and chad chute mounting bracket to the punch.
- d. Loosen one screw (B) which holds one of the support brackets to the front panel.
- e. Loosen and remove the two screws (C₁ and C₂) which hold the punch mounts to the punch support brackets.
- f. The punch is now free and can be removed from the system.
- g. Replacement is the reverse of steps f, e, d, c, and then b.
- h. Perform Section 5.5.2.

6.3 PUNCH REMOVAL (RDF AND RAF UNITS ONLY)

The following procedure should be used when removing the punch. The letters in parenthesis refer to items in Figure 6-2.

- a. Remove all power and control signals from the unit by disconnecting P1/J1, P2/J2, and P3/J3.
- b. Disconnect P9/J9.

- c. Remove the retaining ring (A) which holds the tape-release rod to the punch tape release lever. The retaining ring is located under the tape-release rod.
- d. Remove screw (B) which holds the punch retaining bracket to the tape feed guide.
- e. Loosen and remove the two screws (C1 and C2) which hold the punch mounting bracket to the punch shock mount.
- f. The punch is now free and can be removed from the system.
- g. Replacement is the reverse of steps f, e, d, and then c. When replacing the screws, do not tighten completely until step k.
- h. Place an ohmmeter across the NO and C contacts (center and top contacts respectively) on S6.
- i. Place the RUN-LOAD lever in the LOAD position. The ohmmeter should read zero ohms (switch actuated) and the punch pinch roller should be released to allow tape to pass through the punch.
- j. Place the RUN-LOAD lever in the RUN position. The ohmmeter should read open circuit (switch not actuated) and the punch pinch roller should be engaged against the capstan preventing tape from being inserted.
- k. If the conditions of steps i and j are not satisfied, move the punch in its mounting holes until the conditions are satisfied. If necessary, move the punch shock mounts. Tighten the screws of step g.
- l. Perform the reverse of step b and then a.
- m. Perform Sections 5.5.2.

6.4 FRONT PANEL - CHASSIS SEPARATION (RDB AND RAB UNITS ONLY)

The following procedure should be used when separating the front panel from the chassis. Items in parenthesis refer to callouts in Figure 6-1.

- a. Remove all power and control signals from the unit by disconnecting P1, P2, and P3.
- b. Disconnect J4/P4, J5/P5, J6/P6, J7/P7, and J8/P8.
- c. Remove the four 10-32 x 9/16 machine screws which hold the front panel to the chassis and the one 8-32 x 5/8 machine screw which holds the front panel to the deck assembly. These screws are located at the front of the unit.
- d. Remove the 6-32 x 3/8" screw (D) which holds the deck assembly to the tape punch support bracket and the two 6-32 x 3/8" screws (E) which hold the tape punch support bracket to the side of the chassis.
- e. Remove the one rear screw (C2) which holds the punch mount to the chassis.
- f. The front panel with the punch attached should now be free from the chassis assembly with the tape deck attached.
- g. Reassembly is the reverse of steps f, e, d, c, b, and then a.

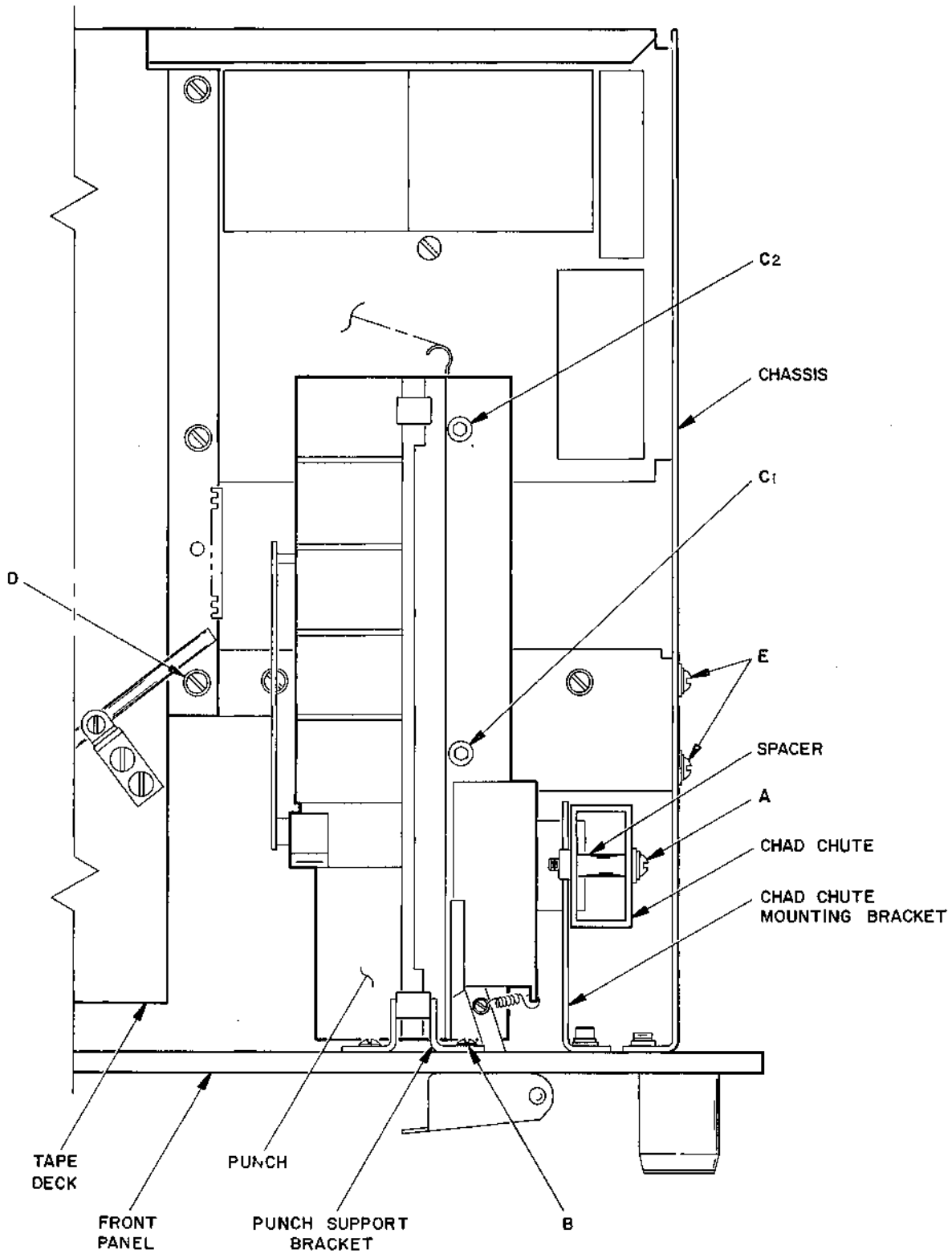

MMC 233

Figure 6-1. Punch and Chassis Mounting Screw Locations, RDB and RAB Units Only.

6.5

FRONT PANEL - CHASSIS SEPARATION (RDF AND RAF UNITS ONLY)

The following procedure should be used when separating the front panel from the chassis. The letters in parenthesis refer to items in Figure 6-2.

- a. Remove all power and control signals from the unit by disconnecting P1/J1, P2/J2, and P3/J3.
- b. Disconnect J4/P4, J6/P6, and J7/P7.
- c. Remove the four 10-32 x 9/16 machine screws which hold the front panel to the chassis and the two 6-32 x 1/2 machine screws (D) which holds the front panel to the tape release bracket. These screws are located at the front of the unit.
- d. The front panel can now be separated from the chassis and punch.
- e. Reassembly is the reverse of steps d, c, b and then a.

6.6

CARD REMOVAL

The following precautions should be used when replacing or removing the printed circuit cards.

- a. Remove all power and control signals by disconnecting P1, P2, and P3 at the rear of the unit.
- b. Never force a card into its connector. The cards pull out and push in firmly, but excessive force should never be required.
- c. If the Control Logic and Feed Hole Driver Card is replaced, perform Section 5.5.2.
- d. If the Step Motor Power Supply card is replaced, perform Sections 5.5.3 and 5.6.3.
- e. If the Step Motor Driver card is replaced, perform Sections 5.6.4 and 5.6.5.

6.7

LOW TAPE ARM - BRAKE BLOCK DISASSEMBLY (RAB AND RDB UNITS ONLY)

The following procedure should be used when replacing any of the items associated with the low tape arm - brake block assembly on the tape deck assembly. The items in parenthesis refer to the items in Figure 6-3.

- a. Remove the nut (A) which holds the spring adjust screw to the brake block assembly and remove the spring adjust screw.
- b. Remove the socket head screw (B) which holds the brake release link (C) to the link swivel (D). Remove the link swivel.
- c. Remove retaining ring (E), low tape arm (F), retaining ring (G), nylon washer (H), spring (I), nylon washer (J), retaining ring (K), and the brake block assembly (L). Leave spacer (M) attached.
- d. Install the new brake block assembly.

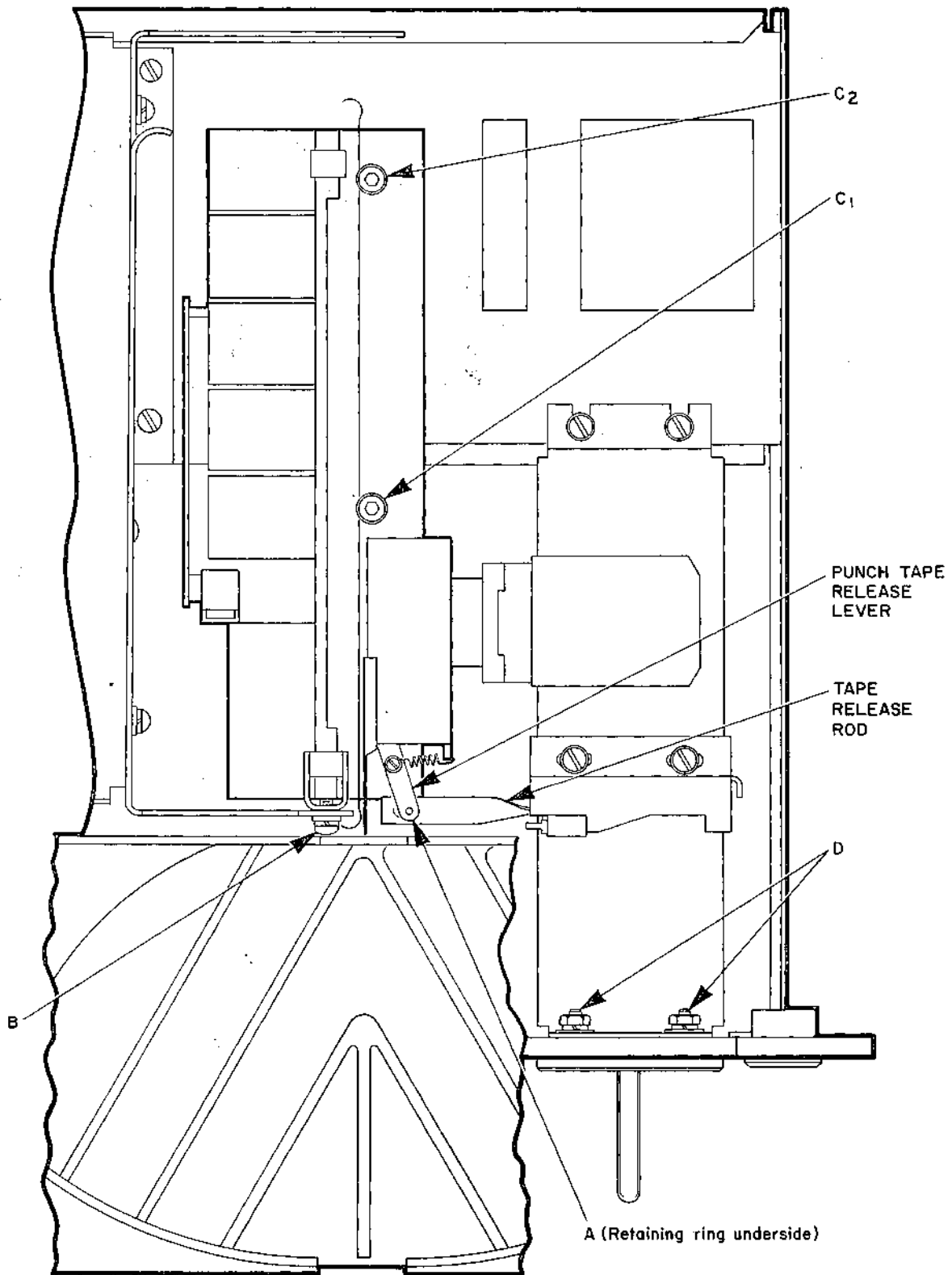

MMC 289

Figure 6-2. Punch and Chassis Mounting Screw Locations, RAF and RDF Units Only.

- e. Reassemble by performing the reverse of steps c, b, and then a. When installing spring (1), make sure the long end of the spring is at the bottom and rests against socket head screw (see Figure 5-2).
- f. Perform Section 5.5.5.2.
- g. Perform Section 5.5.5.3.

6.8 SUPPLY ARM REPLACEMENT (RDB AND RAB UNITS ONLY)

The following procedure should be used when replacing the supply arm:

- a. Remove the set screw which holds the platter assembly to the platter shaft. Slide the platter assembly off. Be careful not to lose the ball bearing in the shaft hole in the platter.
- b. Unhook the tape tension spring from the supply arm.
- c. Remove the grip ring which holds the brake release link to the supply arm. Remove the link and washer.
- d. Remove the flat washer and retaining ring which holds the supply arm to the platter shaft. Remove the supply arm.
- e. Remove the tape roller and install it on the new arm.
- f. Install the new arm and perform the reverse of steps d, c, and b.
- g. Perform Section 5.5.5.1.
- h. Perform Section 5.5.5.3.

6.9 UPPER COVER, READER

The upper cover is held to the front panel by means of a slot head screw and a fixed set screw. The set screw should not be turned. The cover is removed by loosening the slot head screw and lifting the cover straight up. To replace, align the slots in the cover with the slot head screw and the set screw and slide the cover down as far as it will go. Tighten the slot head screw.



When removing or replacing the upper cover, care should be exercised so as not to bump the lamp assembly.

6.10 READ HEAD ASSEMBLY REPLACEMENT

The read head assembly 109697-1 is replaced as a complete unit. Figure 5-3 shows how the assembly is mounted to the front panel. The replacement procedure is as follows:

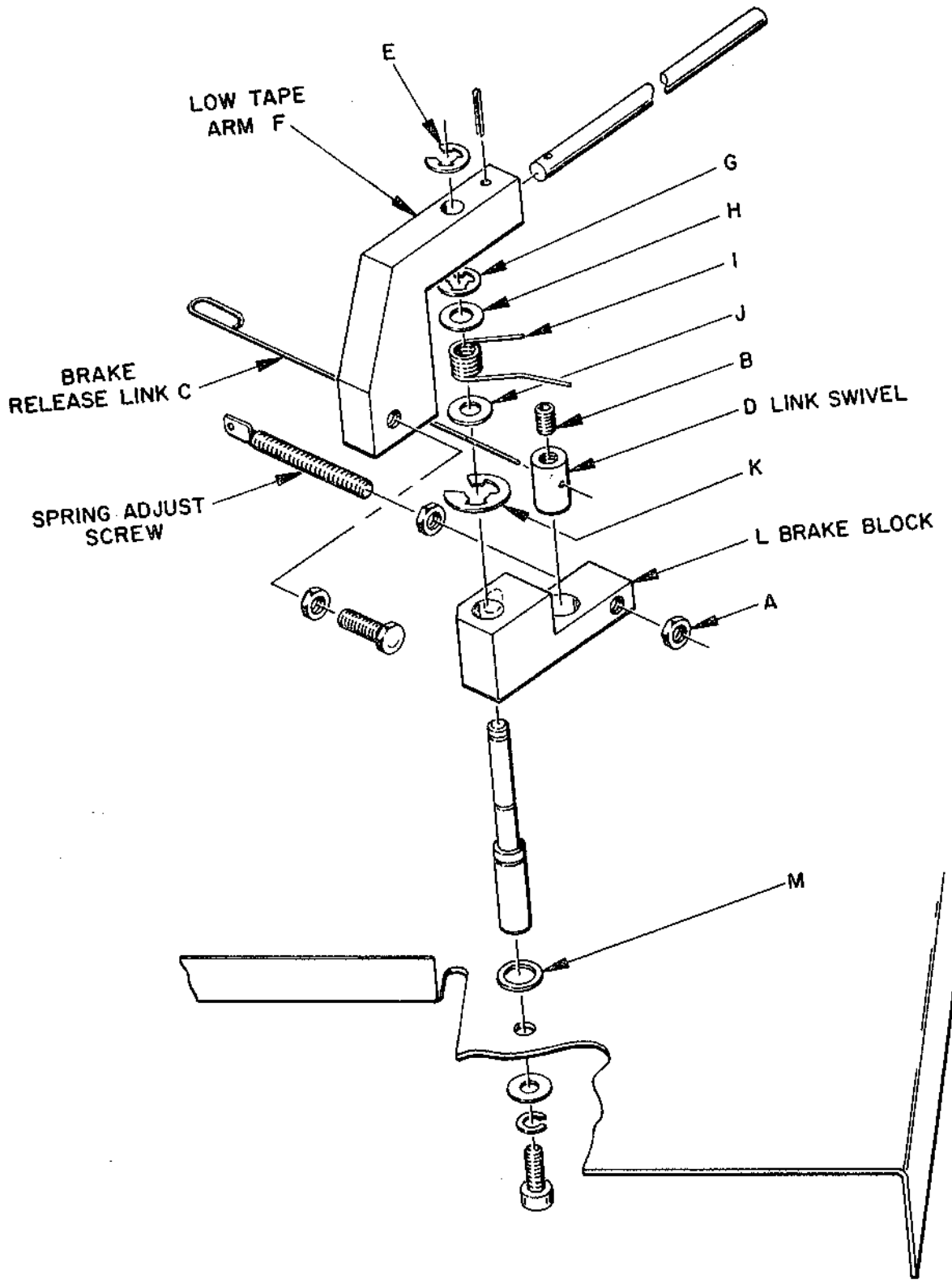

MMC 230

Figure 6-3. Exploded View of Low Tape Arm - Brake Block Assembly.

- a. Remove all power and control signals by disconnecting P1, P2, and P3 at the rear of the unit.
- b. Disconnect P6 from J6 (orange).
- c. Cut the wires going to P6 near the connector.
- d. When ordering a read head assembly, a new connector plug P6 (REMEX part number 706510-208) should also be ordered. The new read head assembly has the pins attached to the cable. The pins are inserted into the connector plug later in this procedure.
- e. Loosen the two 6-32 socket head screws (Item (C), Figure 5-3) which hold the readout assembly to the front panel and remove the read head assembly.
- f. Insert the cable from the new read head assembly through the hole in the front panel.
- g. Perform the reverse of step e. When mounting the read head assembly to the front panel, adjust the read head to properly position the sprocket wheel in the slot in the upper tape guide. The rim of the wheel should match the running surface of the upper guide allowing the teeth to correctly engage the sprocket holes.
- h. Connect the pins of the read head assembly to P6. See Figures 8-1 through 8-4 for proper pin connections to P6.
- i. Connect P6 to J6.
- j. Perform Section 5.6.2. Check the adjustments in Sections 5.6.4 and 5.6.5.

6.11 LIGHT SOURCE ASSEMBLY REPLACEMENT

When a lamp fails, it is recommended that the light source assembly, 109375, be replaced as follows:

- a. Remove all power and control signals by disconnecting P1, P2, and P3 at the rear of the unit.
- b. Remove the upper cover. See Section 6.9.
- c. At the terminals on the light source, unsolder the two wires which come through the front panel and attach to the light source.
- d. Loosen the two screws which hold the light source assembly to the front panel and remove the light source assembly.
- e. Install the new light source assembly and tighten the two screws. Resolder lead wires.
- f. Perform Section 5.6.2, beginning with step g.



Allow sufficient time for the motor to cool before any maintenance. Because of the relatively large amount of power dissipated by the step motor, the temperature of the outside case and the front panel to which it is mounted may become hot enough to produce a burn if touched.

The following procedure should be followed when replacing the step motor assembly. If the step motor assembly needs replacing it is recommended that the entire assembly 109273 be replaced. Refer to Figure 5-3 for letter designations in parenthesis.

- a. Remove all power and control signals by unplugging P1, P2, and P3 at the rear of the unit.
- b. Disconnect P7 from J7 (yellow).
- c. Loosen the two set screws (E) that hold the sprocket wheel to the step motor shaft.
- d. Loosen the two set screws that hold the step motor assembly to the heat sink and slide the step motor assembly back away from the heat sink. Connector P7 is part of the step motor assembly and should be discarded with the old motor. The replacement step motor assembly 109273 will have a connector with it.
- e. Place the sprocket wheel in the upper and lower tape guide slots and slide the motor shaft through the sprocket wheel by performing the reverse of step d. See Figure 5-3. Rotate the sprocket wheel so that one of the set screws will tighten on the flat of the motor shaft.
- f. Connect P1/J1, P2/J2, P3/J3 and P7/J7.
- g. Perform Section 5.6.2. Check the adjustments in Sections 5.6.4 and 5.6.5.

Replacement of the transformer is accomplished as follows:

- a. Remove all power and control signals by disconnecting P1, P2, and P3 at the rear of the unit.
- b. Unsolder the wires at all terminals. Identify each wire (including the jumper wires) as it is removed so it can be replaced in the proper position. Proper operation requires that these wires be correctly replaced.
- c. Remove the four 8-32 round head machine screws and nuts that hold the transformer to the chassis.

- d. Insert new transformer and mount it to the chassis.
- e. Refer to Section 5.5.6 for connection of terminal 2 and 3 depending upon voltage requirement.
- f. Replace the other leads removed in step b. (Do not forget the jumpers.)
- g. Perform the reverse of steps c, b and then a.

SECTION VII

PARTS LIST

7.1 GENERAL

This section lists the electronic and mechanical parts used on the RAB3075BC1, RDB3075BC1, RAF3075BC1 and RDF3075BC1. Because of the similarity of units, the list is given in two parts: the RAB and RDB units are covered in Section 7.4 with Figures 7-2 through 7-7 illustrating the component locations, the RAF and RDF units are covered in Section 7.5 with Figures 7-8 through 7-12 illustrating the component locations. Standard hardware items are not listed. An X in a particular model number digit designator denotes any of the combinations given in Figure 1-5 for that designator is applicable.

Indented items are part of the assembly under which they are indented and the quantity of these items are per each assembly. Reference designations refer to the parts illustrated in Figures 7-2 through 7-12. All electronic components are identified by letter-number combinations in the Reference Designation column and mechanical parts are identified by number. Reference designations in parenthesis are associated with or function with the parenthetical item. These items are generally individual items and not part of an assembly, but for reference are related back to the associated item. Those items identified by a broken arrow in Figures 7-1 through 7-12 indicate the approximate location of parts not visible in the photograph.

Section 7.3 lists the recommended spare parts. Tables 7-1 through 7-5 and Figures 7-13 through 7-17 contain the printed circuit card components and photographs of the card. Note that each card shows the parts list on the left, the photo on the right and, if required, the schematic can be folded out to the right from Section 8 and the timing diagram can be folded out to the left from Section 4, all in view at once. Section 7.6 lists the various options available on the 3075 units.

The parts list for the punch mechanism, Model RPM1075, is contained in the separate manual for that unit.

All parts are available from REMEX Spares Order Desk, 1733 Alton Street, Santa Ana, California 92705.

7.2 KIT OF PARTS

The kit of parts contains items used for installation and maintenance and is shipped with the unit. Refer to Table 1-1, Equipment Supplied. Some of these parts are also repeated in Sections 7.4 and 7.5 for reference.

7.3 RECOMMENDED SPARE PARTS

Section 7.3.1 lists the recommended spare parts for the RAB and RDB3075 and Section 7.3.2 lists the recommended spare parts for the RAF3075 and RDF3075. Recommended spare parts for the RPM1075 punch mechanism are listed in the manual for that unit.

7.3.1 RECOMMENDED SPARE PARTS, MODELS RAB3075 AND RDB3075

Description and Manufacturer's Part No.	REMEX Part No.	Quantity	Reference Designation
Diode, 1N5059 or 1N4003	704000-107	1	CR1-CR3
Diode, Zener, 5.6V, 1N4561	704022-103	1	Z1
Fuse, 2.5 Amp, 250V Slow-Blow (100, 115, or 127 VAC Operation Only)	705710-124	1	F1
Fuse 1.5 Amp, 250V, Slow-Blow (220, 240 VAC Operation Only)	705710-138	1	F1
Lamp, Red Indicating, 28V Dialco 507-3917-0331-600	715071-122	1	DS1
Light Source Assembly	109375	1	DS2
Printed Circuit Card Assembly, Control Logic and Feed Hole Driver (See Table 7-1 for dash number determination)	110261-XX	1	
Printed Circuit Card Assembly, Data Logic and Driver (See Table 7-2 for dash number determination.)	110251-X	1	
Printed Circuit Card Assembly, Power Supply	109061-2		
Printed Circuit Card Assembly, Step Motor Driver (See Table 7-4 for dash number determination.)	109891-6X1	1	
Read Head Assembly	109697-1	1	
Rectifier Bridge, Motorola MDA962A-2	704005-130	1	BR1
Switch, Base, Cutler Hammer SC2CX	715061-100	1	S1, S4, (S3*)
Switch, Base, Cutler Hammer SC2GX	715061-200	1	S2
Switch, Base, Cutler Hammer SC2JX	715061-400	1	S5 (S3*)

* Note: The RDB3075 uses 715061-100 for S3 and the RAB3075 uses 715061-400 for S3.

7.3.1

RECOMMENDED SPARE PARTS, MODELS RAB3075 AND RDB3075 (Continued)

Description and Manufacturer's Part No.	REMUX Part No.	Quantity	Reference Designation
Switch, Limit, Micro Switch 311SM778-H4	715058-126	1	S6
Switch, Micro Switch 311SM68-H4	715058-125	1	S7
Switch, Micro Switch 311SM723-H4	715058-127	1	S8
Transistor, Heat Sink Assembly Motorola MJE1101	704204-119	1	Q1-Q3
Transistor, Read Motor Amplifier Card, Motorola MJE1100	704204-115	1	Q1-Q3

7.3.2

RECOMMENDED SPARE PARTS, MODELS RAF3075 AND RDF3075

Description and Manufacturer's Part No.	REMUX Part No.	Quantity	Reference Designation
Diode, 1N5059 or 1N4003	704000-107	1	CR1-CR3
Diode, Zener, 5.6V, 1N4561	704022-103	1	Z1
Fuse 2.5 Amp, 250V, Slow-Blow (<u>100,115 or 127 VAC Operation</u>)	705710-124	1	F1
Fuse 1.5 Amp, 250V, Slow-Blow (<u>220 or 240 VAC Operation</u>)	705710-138	1	F1
Lamp, Red, Indicating, 28V, Dialco 507-3917-0331-600	715071-122	1	DS1
Light Source Assembly	109375	1	DS2
Printed Circuit Card Assembly, Control Logic and Feed Hole Driver (See Table 7-1 for dash number determination.)	110261-XX	1	
Printed Circuit Card Assembly, Data Logic and Driver (See Table 7-2 for dash number determination.)	110251-X	1	
Printed Circuit Card Assembly, Power Supply	109061-2	1	
Printed Circuit Card Assembly, Step Motor Driver (See Table 7-4 for dash number determination.)	109891-6X1	1	
Read Head Assembly	109697-1	1	
Rectifier Bridge Motorola MDA962A-2	704005-130	1	BR1
Switch, Base, Cutler Hammer SC2CX, <u>RAF3075</u>	715061-100	1	S1,S4
Switch, Base, Cutler Hammer SC2CX, <u>RDF3075</u>	715061-100	1	S1,S2,S4
Switch, Base, Cutler Hammer SC2GX, <u>RAF3075</u>	715061-200	1	S2,S3
Switch, Base, Cutler Hammer SC2JX, <u>RDF3075</u>	715061-400	1	S3,S5
Switch, Base, Cutler Hammer SC2JX, <u>RAB3075</u>	715061-400	1	S5
Switch, Limit, Micro Switch 311SM778-H4	715058-126	1	S7
Transistor, Heat Sink Assembly, Motorola MJE1101	704204-119	1	Q1-Q3
Transistor, Read Motor Amplifier Card, Motorola MJE1100	704204-115	1	Q1-Q3

NOTE: WHEN ORDERING SPARE PARTS, CONTACT REMEX SPARES ORDER DESK AND REFERENCE COMPLETE MODEL AND SERIAL NUMBER OF UNIT. ALWAYS REFER TO ADDENDUM (IF PRESENT) AT THE REAR OF THE MANUAL FOR POSSIBLE PAET NUMBER CHANGES.

7.4 PARTS LIST, RAB3075 AND RDB3075

Description and Manufacturer's Part No.	REMEX Part No.	Quantity	Reference Designation
Top Assembly, RAB3075BC1	110410-1	1	Ref.
Top Assembly, RDB3075BC1	110420-1	1	Ref.
The subassemblies for 110410-1 and 110420-1 are the same except as noted:			
Bracket, Tape Punch Support	109444	1	1
Cable Assembly, <u>RDB3075BC1 Only</u>	110374-1	1	(P1,P3)
Connector, Cannon DB-25P	706500-231	1	P1
Connector, Housing, 15 Pin, Modified	109143	1	P3
Contact, Pin, Amp 61121-1LP	706530-131	1	(P3)
Cover, Connector, Cannon DB19678-2	706540-136	1	(P1)
Screw Lock Assembly, Male, Cannon D-20419-1	706540-124		
Chad Bin	110333-1	1	2
Chad Chute	109442-1	1	3
Chassis Assembly	110392-1	1	Ref.
Bracket Assembly, Connector	109805-1	1	(J1-J3,F1,C2)
Bracket, Connector Mounting	109807-1	1	4
Capacitor, 2 x .01 µf, 125 VAC Dual Ceramic, Sprague 36C219	702127-103	1	C2A/B
Connector, Cannon DB-25S	706510-211	1	J1
Connector, Amphenol 160-5	706500-104	1	J2
Connector, Amp 1-480423-0	706500-223	1	J3
Fuse, 2.5 Amp, 250V, Slow-Blow (100,115,127 VAC Operation)	705710-124	1	F1
Fuse, 1.5 Amp, 250V, Slow-Blow, (220, 240 VAC Operation)	705710-138	1	F1
Fuseholder, Littlefuse 342004	705750-100	1	(F1)
Screw Lock Assembly, Female Cannon D-20418-2	706540-123	2	(J1)
Socket, Insert Contacts, Amp 61123-1LP	706530-132	12	(J3)
Bracket, Support	109443	1	5
Capacitor, 21K µf, 40V, Electrolytic STM 71C40CC213	702313-104	1	C1
Chassis	109589-1	1	6
Clamp, Cable, Thomas/Betts TC-342A	715040-141	1	
Connector, Housing, 7 Pin, Amp 1-480421-0, White	706500-221	1	J4
Connector, Housing, 15 Pin, Amp 1-480423, White	706500-223	1	J5
Connector, Housing, 12 Pin, Amp 1-480409-3, Orange	706500-229	1	J6
Connector, Housing, 7 Pin, Amp 1-480421-4, Yellow	706500-226	1	J7
Connector, Housing, 7 Pin, Amp 1-480421-7, Violet	706500-228	1	J8
Connector, P.C. Card, S.A.E. SAC22D/1-2	706510-212	3	J10,J12,J13
Connector, P.C. Card, S.A.E. SAC22S/1-2	706510-204	2	J9, J11
Contact, Connector, Socket, Amp 61123-1LP	706530-132	40	(J4-J8)

NOTE: WHEN ORDERING SPARE PARTS, CONTACT REMEX SPARES ORDER DESK AND REFERENCE COMPLETE MODEL AND SERIAL NUMBER OF UNIT. ALWAYS REFER TO ADDENDUM (IF PRESENT) AT THE REAR OF THE MANUAL FOR POSSIBLE PART NUMBER CHANGES.

7.4 PARTS LIST, RAB3075 AND RDB3075 (Continued)

Description and Manufacturer's Part No.	REMEX Part No.	Quantity	Reference Designation
Decal, Fuse Value	109599-1	1	7
Diode, Zener, 5.6V, 1N4561	704022-103	1	Z1
Heat Sink Assembly	110349-1	1	(Q1-Q3)
Diode, 1N5059 or 1N4003	704000-107	3	CR1-CR3
Heat Sink, Ierc E1C03-0655B	715033-117	1	(Q1-Q3)
Transistor, Motorola MJE1101	704204-119	3	Q1-Q3
Key, Polarizing, S.A.E. 007900	706540-134	4	(J10-J13)
Printed Circuit Card Assembly, Read Motor Amplifier	110011-1	1	PC1
Diode, 1N5059 or 1N4003	704000-107	3	CR1-CR3
Transistor, Motorola MJE1100	704204-115	3	Q1-Q3
Rectifier, Bridge, Motorola MDA962A-2	704005-130	1	BR1
Resistor, 2.5 ohm, 50W, 3%, Wirewound, Dale RH50-3%	701182-R50	1	R1
Resistor, 3 ohm, 5W, Axial, Ohmite 995-5B	701016-3R0	1	R2
Shield, Transformer	109596-1	1	(T1)
Spacer, Nylon, 1/4 dia x 5/16, Weckesser SP-45	715030-163	2	8
Spacer, 5/16 long, Amatom 9225-A-0140-1B	715030-178	2	9
Spacer, 7/16 long, Amatom 9227-A-0140-1B	715030-179	2	10
Strap, Capacitor	109458	1	(C1)
Terminal Strip, 4 terminals, Cinch Jones 54B	715010-121	1	TB2
Transformer, REMEX Specification	703010-135	1	T1
Connector, Cannon DB-25P	706500-231	1	P1
Connector, 15 pin modified	109143	1	P3
Cover, Chad Bin	110336-1	1	11
Cover, Chad Chute	109567-1	1	12
Cover, Upper	109790-1	1	13
Decal, Identification Nameplate	109595-1	1	14
Decal, Patent Pending	108547	1	15
Decal, Punch Lub	110388-1	1	16
Deck Assembly	110343-1	1	Ref.
Arm, Low Tape	110387-3	1	17
Arm, Tape Supply	110387-2	1	18
Blade Fan, Howard 6-218-125	715076-110	1	(M3)
Bracket, Mounting, Catch	109566-1	1	19
Brake Block Assembly	109446	1	20
Bumper, Rubbercraft 9114	715021-115	2	21
Catch, Low Tape Arm, Builders Brass Works BW-801	713656-120	1	22
Clamp, Cable, Weckesser HPC25	715040-137	2	23
Connector, Housing, Amp 1-480420-0, 7 pin	706510-201	1	P4
Contact, Pin, Amp 61121-1LP	706530-131	7	(P4)
Deck, Tape Supply	109565-1	1	24
Grommet, General Cement 1042	715020-107	1	25
Grommet, Caterpillar, 2 inch, Nylon Mould Co. G51H-A	715020-111	1	26

NOTE: WHEN ORDERING SPARE PARTS, CONTACT REMEX SPARES ORDER DESK AND REFERENCE COMPLETE MODEL AND SERIAL NUMBER OF UNIT. ALWAYS REFER TO ADDENDUM (IF PRESENT) AT THE REAR OF THE MANUAL FOR POSSIBLE PART NUMBER CHANGES.

7.4 PARTS LIST, RAB3075 AND RDB3075 (Continued)

Description and Manufacturer's Part No.	REMEX Part No.	Quantity	Reference Designation
Link, Brake Release	109426	1	27
Motor, Fan, Howard 1075-10-3038	715075-172	1	M3
Ring, Grip, Truarc 5555-18-H	715025-138	1	28
Ring, Retainer, Truarc 5100-37MF	715025-114	1	29
Ring, Retainer, Truarc 5133-25	715025-136	1	30
Ring, Retainer, Truarc 5144-18	715025-142	2	31
Screw, Spring Adjust	109464-1	1	32
Screw, Spring Adjust	109464-3	1	33
Shaft, Low Tape Arm	109429	1	34
Shaft, Platter	109568-1	1	35
Shroud, Fan	110118-1	1	36
Spacer, 3/8 x 1/2 x .020, P.I.C. 83-10	715030-174	1	37
Spacer, Tape Roller	109581-1	2	38
Spring, Torsion, Assoc. Spring Co. TO21-360-18U	714090-117	1	39
Spring, Extension, Lane Spring Co. 168-A	714090-118	1	40
Spring, Extension, Lane Spring Co. 179-B	714090-119	1	41
Switch, Supply Error, Micro Switch 311SM68-H4	715058-125	1	S7
Switch, Low Tape, Micro Switch 311SM723-44	715058-127	1	S8
Swivel	109428	1	42
Tape Roller Assembly	102202	3	43
Front Panel Assembly, RAB3075BC1	110416-1	1	Ref.
Front Panel Assembly, RDB3075BC1	110419-1	1	Ref.
The subassemblies for 110416-1 and 110419-1 are identical except as indicated:			
Actuator, Run/Load	109418-2	1	44
Actuator, Run/Load	110338-1	1	45
Axle, Tape Roller	109084-1	1	46
Bracket, Chad Chute Mounting	109441	1	47
Bracket, Run/Load	110348-1	1	48
Bracket, Support	109443	2	49
Cap, Rocker, POWER	715062-101	1	(S1)
Cap, Rocker, SPOOL	715062-105	1	(S2)
Cap, Rocker ← (RAB3075 ONLY)	715062-111	1	(S3)
Cap, Rocker → (RDB3075 ONLY)	715062-108	1	(S3)
Cap, Rocker, LOAD	715062-103	1	(S4)
Cap, Rocker, FEED/DELETE	715062-110	1	(S5)
Capacitor, .1 uf, 200V, Ceramic (RDB3075 ONLY)	702128-104	1	C3
Clip, Lamp Retaining, Dialco 515-0051	715072-104	1	(DS1)
Connector, Housing, 15 pin, Amp 1-480422-0, White	706510-203	1	P5
Connector, Housing, 12 pin, Amp 1-480408-3, Orange	706510-208	1	P6*
Connector, Housing, 7 pin, Amp 1-480420-7, Violet	706510-207	1	P8

* Must also be ordered when replacing the Read Head assembly.

NOTE: WHEN ORDERING SPARE PARTS, CONTACT REMEX SPARES ORDER DESK AND REFERENCE COMPLETE MODEL AND SERIAL NUMBER OF UNIT. ALWAYS REFER TO ADDENDUM (IF PRESENT) AT THE REAR OF THE MANUAL FOR POSSIBLE PART NUMBER CHANGES.

7.4 PARTS LIST, RAB3075 AND RDB3075 (Continued)

Description and Manufacturer's Part No.	REMEX Part No.	Quantity	Reference Designation
Connector, Plug, Dialco 515-0050	706515-126	1	(DS1)
Contact, Pin, Amp 61121-1LP	706530-131	29	(P4,P6,P8)
Decal, RUN/LOAD	109939-1	1	50
Handle, Small Part Inc. 125A	715021-118	1	51
Handle Assembly, Southco 34-10-301-10	714096-110	2	52
Heat Sink	109268-2	1	53
Hub, Motor	109963-1	1	54
Lamp, Red Indicating, 28V Dialco 507-3917-0331-600	715071-122	1	DS1
Light Source Assembly	109375	1	DS2
Logo	109782-1	1	54A
Lug, Female, Quick Disconnect, Amp 42470-1	715005-125	2	(S6)
Lever, Run/Load	110347-1	1	54B
Motor Assembly	109968-1	1	M1
Nut, Tinnerman, Push-On C637-012	713500-135	2	55
Panel, Front	110417-2	1	56
Plate, Access	109810-2	1	57
Plate, Back	109962-1	1	58
Read Head Assembly - When replacing the sensor assembly, order complete 109697-1 assembly. See Section 6.10. Also order P6 (706510-208) when ordering a new read head assembly. See Figure 7-1 for assembly.	109697-1	1	59
Mounting Block Read Head	109695-1	1	
Sensor, Photoelectric	109673-1	1	
Shaft, Lower Guide	109106	1	
Spacer, Read Head	109671-1	1	
Spring, Leaf	109794-1	1	
Spring, Torsion	109111	1	
Tape Guide, Lower	109796-1	1	
Tape Guide, Upper	109103	1	
Resistor, 100 ohm, 1/4 W	701003-101	1	R3,R6-R9
Resistor, Variable, 25 ohm, 25W, Ohmite 2-K40D	701825-250	1	R4
Resistor, 15 ohm, 10W	701020-150	1	R5
Roller, Tape	104802-2	1	60
Shroud, Tape Exit	110114-1	1	61
Spacer, NAS43 DDO-24	715030-111	1	62
Spacer (RDB3075 Only), Amatom 9319-26SS-140	715030-167	1	63
Spacer, 3/8 long x 0.180 O.D., Secs Inc. EH14-2	715030-200	RAB-1 RDB-2	63
Spacer, Tape Guide	109340	1	65
Spring, Compression, Lee LC-038D-1	714090-126	1	66
Spring, Lane Spring Co 291	714090-116	1	67
Spring, Hub	100531	1	68
Sprocket, REMEX Specification	716057-102	1	69

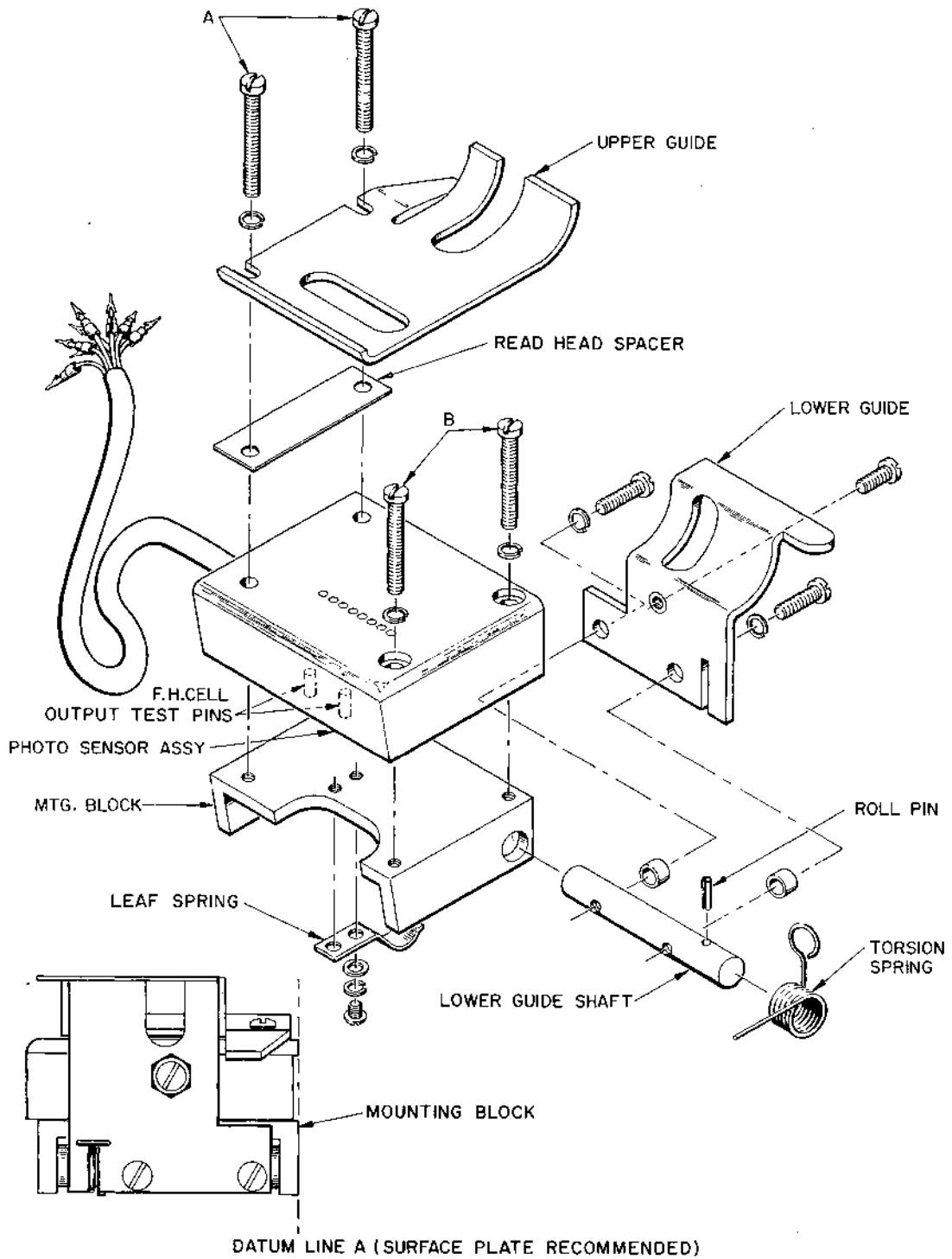

MMC 221 B

Figure 7-1. Exploded View of Read Head Assembly. For reference only. When replacing the Sensor Assembly, the complete Read Head Assembly should be replaced.

NOTE: WHEN ORDERING SPARE PARTS, CONTACT REMEX SPARES ORDER DESK AND REFERENCE COMPLETE MODEL AND SERIAL NUMBER OF UNIT. ALWAYS REFER TO ADDENDUM (IF PRESENT) AT THE REAR OF THE MANUAL FOR POSSIBLE PART NUMBER CHANGES.

7.4 PARTS LIST, RAB3075 AND RDB3075 (Continued)

Description and Manufacturer's Part No.	REMEX Part No.	Quantity	Reference Designation
Standoff, NAS43 DD0-8	715030-138	2	70
Standoff, NAS43 DD1-38	715030-176	2	71
Standoff, 1.5 long, Amatom 8169-A-0440-1B	715030-194	1	72
Step Motor Connector Assembly	109273	1	(M2,P7)
Connector, Amp 1-480420-4, Yellow	706510-205	1	P7
Motor, Stepper, IMC Magnetic, 28VDC	715075-158	1	M2
Pin, Connector, Amp 61121-1LP	706530-131	4	(P7)
Switch Assembly	715061-156	2	(S1,S4)
Base Switch, Cutler Hammer SC2CX	715061-100	1	S1,S4
Bezel, Black	715061-006	1	
Lamp, 28V, Cutler Hammer SW8FL-L1	715061-050	1	
Switch Assembly	715061-256	1	(S2)
Base Switch, Cutler Hammer SC2GX	715061-200	1	S2
Bezel, Black	715061-006	1	
Lamp, 28V, Cutler Hammer SW8FL-L1	715061-050	1	
Switch Assembly (RDB3075 Only)	715061-156	1	(S3)
Base Switch, Cutler Hammer SC2CX	715061-100	1	S3
Bezel, Black	715061-006	1	
Lamp, 28V, Cutler Hammer SW8FL-L1	715061-050	1	
Switch Assembly (RAB3075 Only)	715061-456	1	(S3)
Base Switch, Cutler Hammer SC2JX	715061-400	1	S3
Bezel, Black	715061-006	1	
Lamp, 28V, Cutler Hammer SW8FL-L1	715061-050	1	
Switch Assembly	715061-456	1	(S5)
Base Switch, Cutler Hammer SC2JX	715061-400	1	S5
Bezel, Black	715061-006	1	
Lamp, 28V, Cutler Hammer SW8FL-L1	715061-050	1	
Switch, Limit, Micro Switch 311SM778-H4	715058-126	1	S6
Tape Guide, Edge, Front	109113-1	1	73
Tape Guide, Edge, Rear	109113-2	1	74
Gasket, Chad Chute	109439	1	(3)
Guide, Chad Bin, Unitrack 58-30-40	716053-146	2	(2)
Nut, Tinnerman C-8091-632-4	713500-133	2	75
Platter Assembly	109580-1	1	76
Hub, Platter	110386-1	1	
Ball, 0.375 dia., Stainless	716014-104	1	
Spring, Hub	109452-2	1	
Power Cord, 10 ft, Belden 17460-S	708000-020	1	P2
Printed Circuit Card Assembly, Control Logic and Feed Hole Driver (See Table 7-1 for assembly and dash number determination and Figure 7-12 for component location.)	110261-XX	1	77
Printed Circuit Card Assembly, Data Logic and Driver (See Table 7-2 for assembly and dash number determination and Figure 7-B for component location.)	110251-X	1	78

NOTE: WHEN ORDERING SPARE PARTS, CONTACT REMEX SPARES ORDER DESK AND REFERENCE COMPLETE MODEL AND SERIAL NUMBER OF UNIT. ALWAYS REFER TO ADDENDUM (IF PRESENT) AT THE REAR OF THE MANUAL FOR POSSIBLE PART NUMBER CHANGES.

7.4 PARTS LIST, RAB3075 AND RDB3075 (Continued)

Description and Manufacturer's Part No.	REMEX Part No.	Quantity	Reference Designation
Printed Circuit Card Assembly, Power Supply (See Table 7-3 for assembly and Figure 7-14 for component location.)	109061-2	1	79
Printed Circuit Card Assembly, Step Motor Driver (See Table 7-4 for assembly and cash number determination and Figure 7-15 for component location.)	109891-6X1	1	80
Punch, (See Punch Manual for Assemblies.)	716070-101	1	81
Spacer, 3/8" o.d. x .625 long NAS43 DD4-40	715030-180	1	82
Spacer, 1/4" o.d. x .625 long NAS43 DD1-40	715030-195	1	83
Stand-Off, Amatom 8172-A-0632	715030-168	2	84
Tag, Caulton	109781	1	85

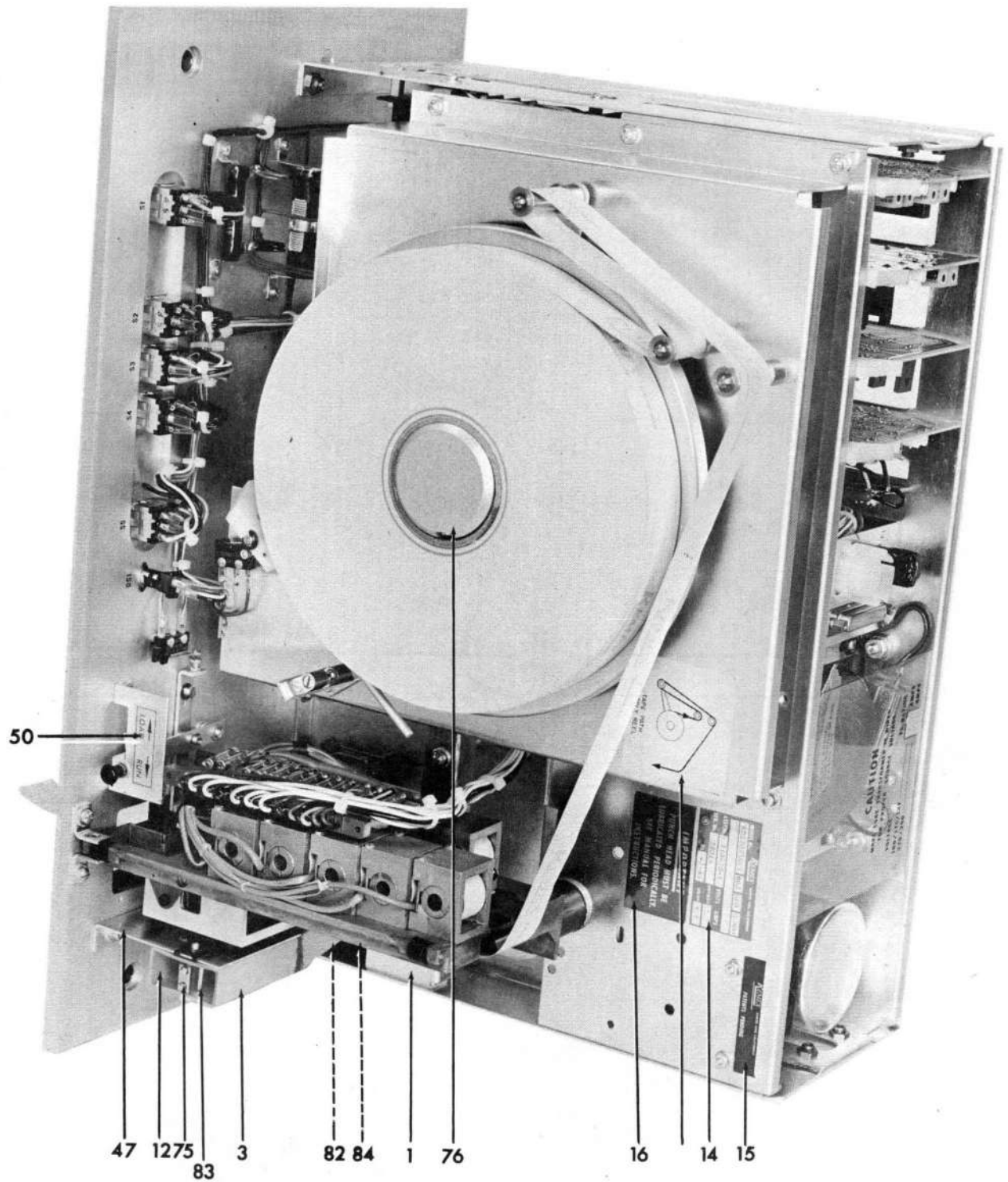

Figure 7-2. RDB3075BCX, Top View, Showing the Threading of the Tape

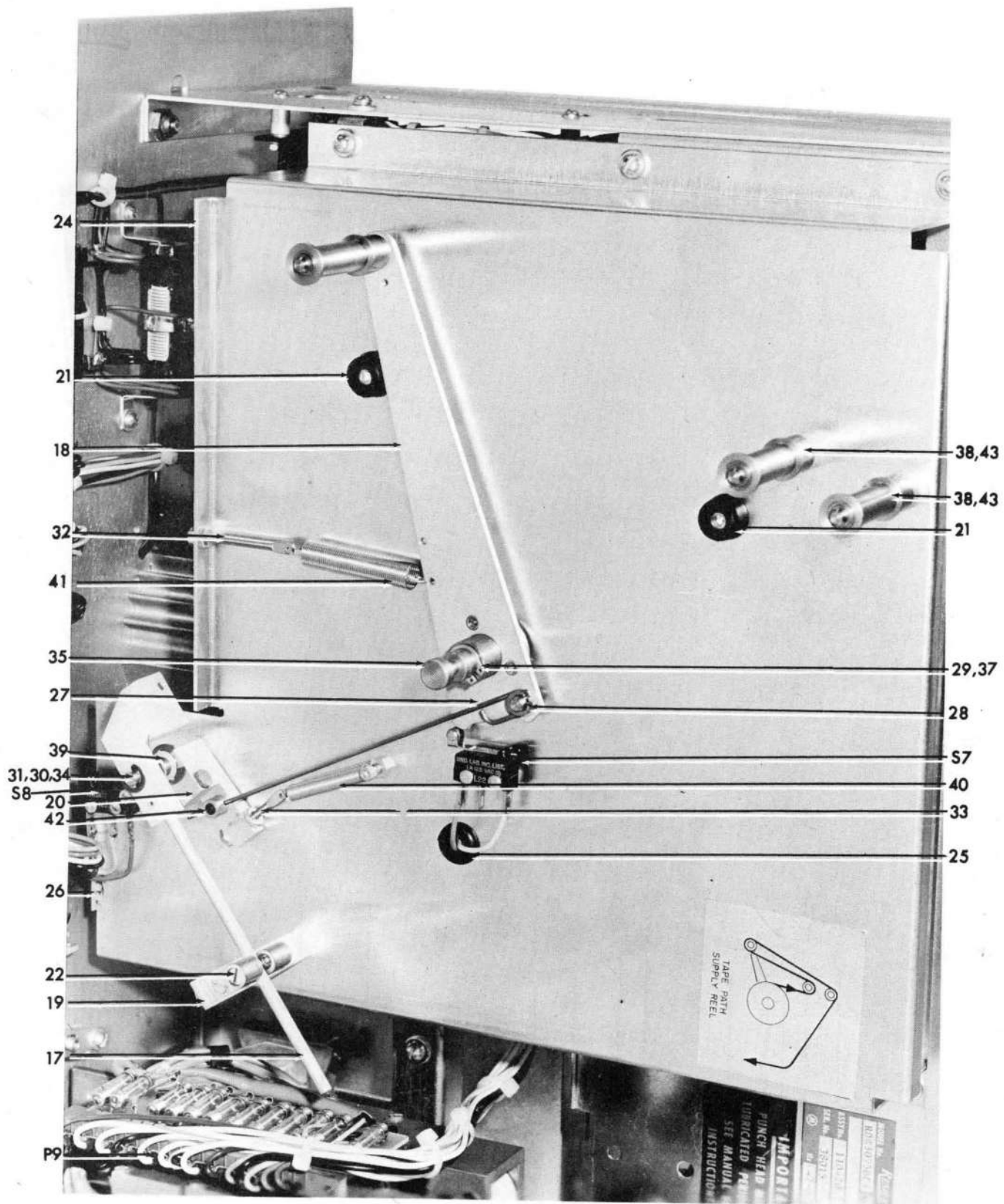

Figure 7-3. RDB3075BCX, Top View of Deck Assembly with Hub Assembly

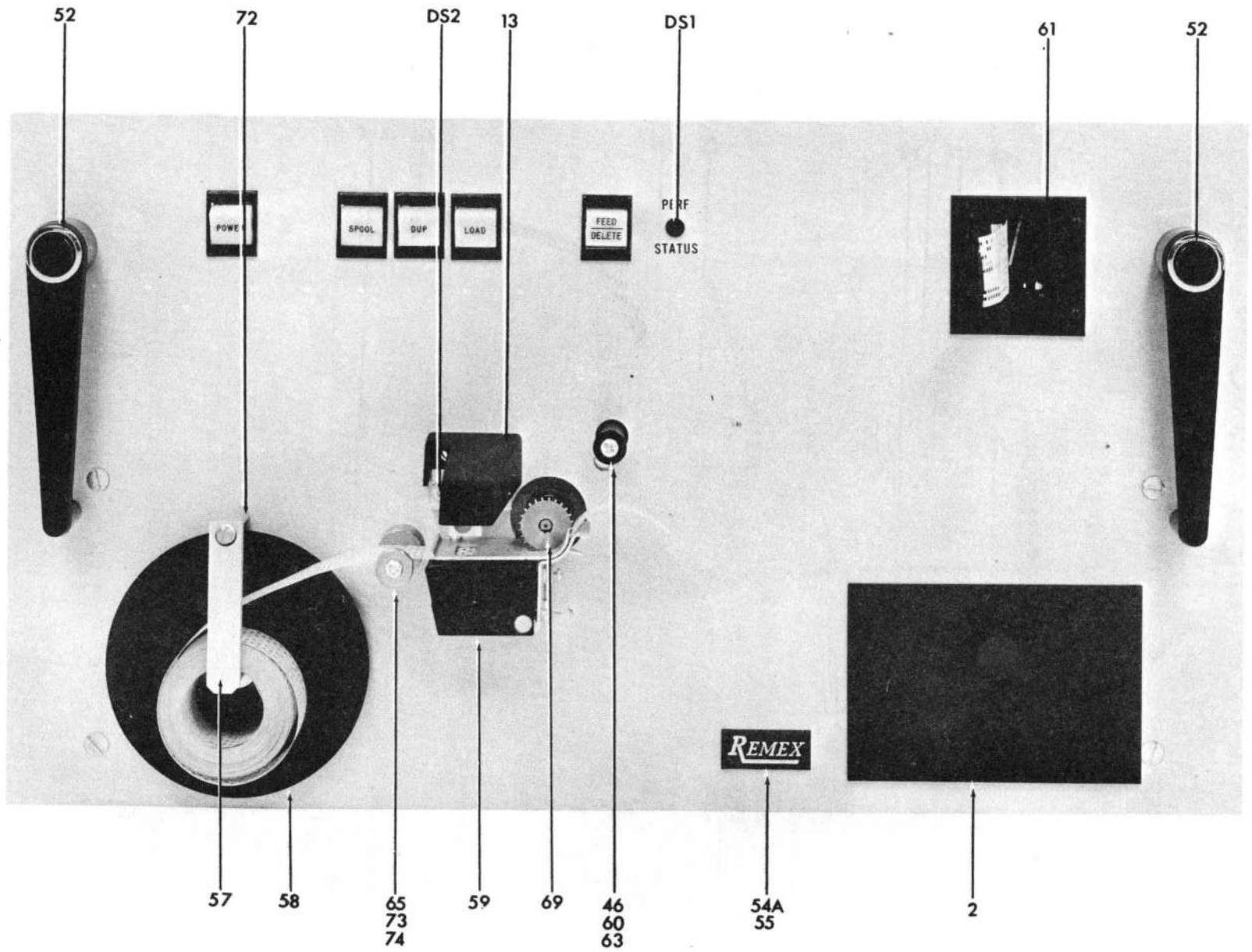

Figure 7-4. RDB3075BCX, Front View of Front Panel

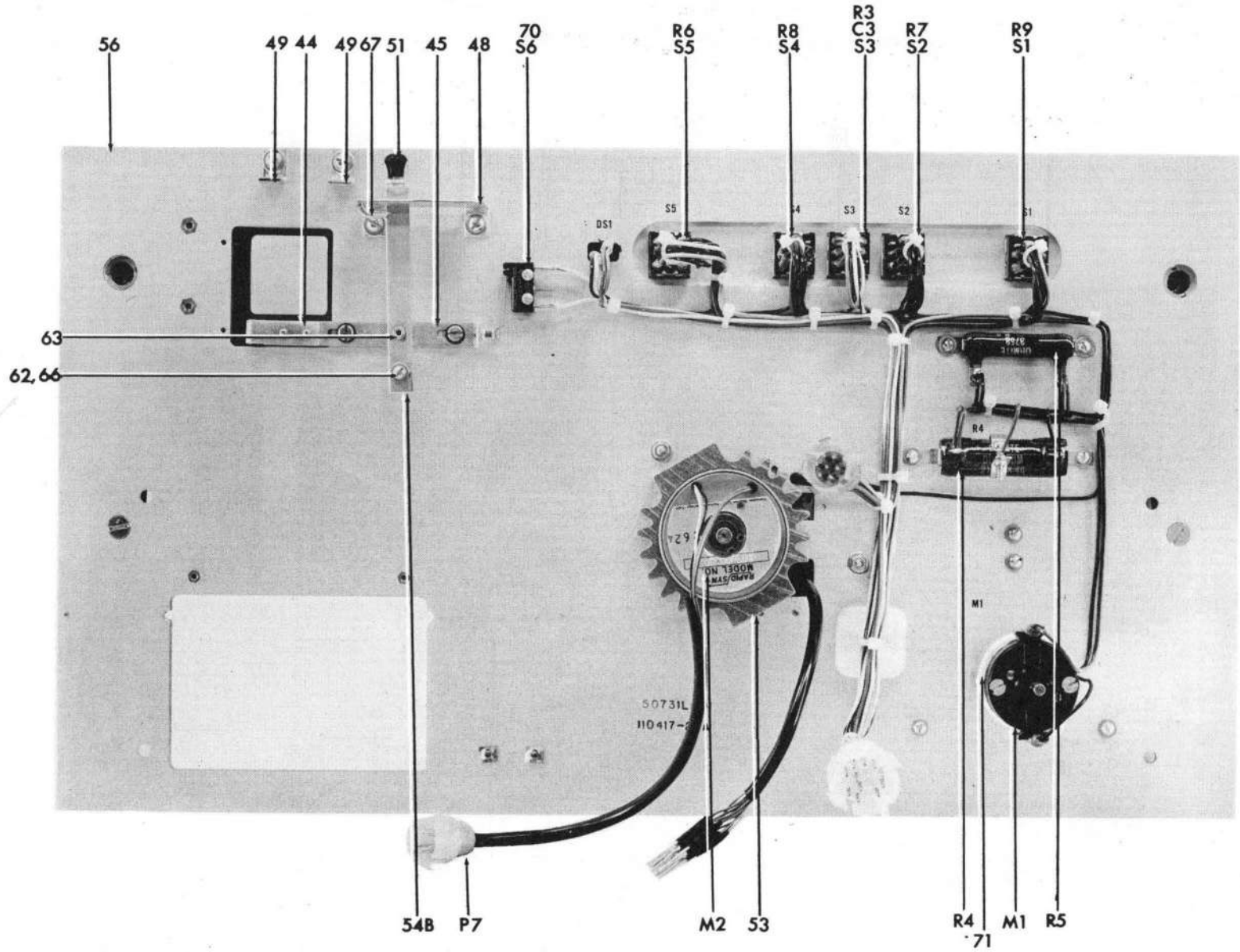

Figure 7-5. RDB3075BCX, Rear View of Front Panel

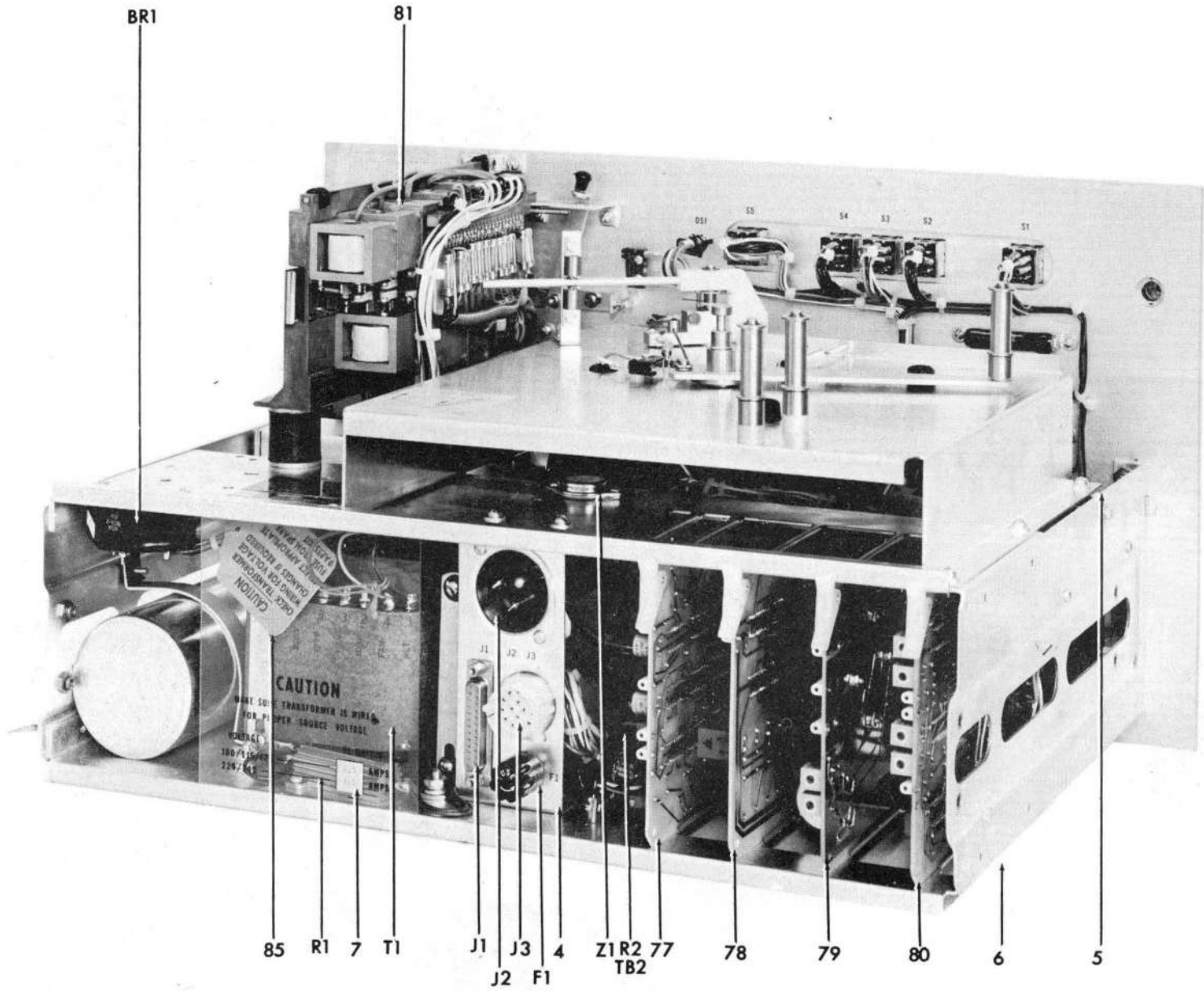

Figure 7-6. RDB3075BCX, Rear View

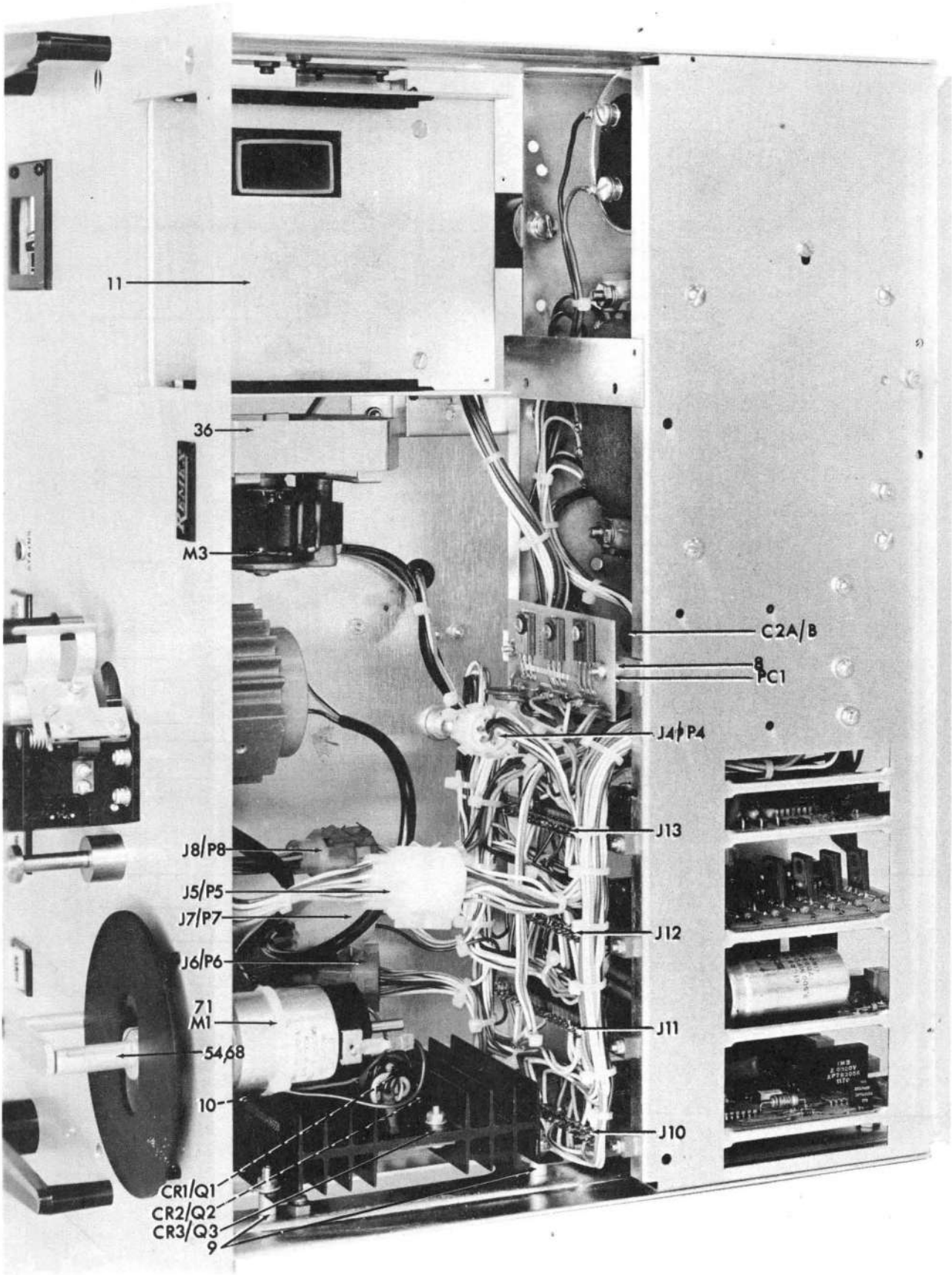

Figure 7-7. RDB3075BCX, Bottom View

NOTE: WHEN ORDERING SPARE PARTS, CONTACT REMEX SPARES ORDER DESK AND REFERENCE COMPLETE MODEL AND SERIAL NUMBER OF UNIT. ALWAYS REFER TO ADDENDUM (IF PRESENT) AT THE REAR OF THE MANUAL FOR POSSIBLE PART NUMBER CHANGES.

7.5

PARTS LIST RAF3075 AND RDF3075

Description and Manufacturer's Part No.	REMEX Part No.	Quantity	Reference Designation
Top Assembly, RAF3075BC1	110400-1	1	Ref.
Top Assembly, RDF3075BC1	110380-1	1	Ref.
The subassemblies for 110400-1 and 110380-1 are the same except as noted:			
Adapter, Chad Exhaust	716072-207	1	1
Bin, Chad	110368-1	1	2
Blade, Fan, Howard 6-218-125	715076-110	1	(M3)
Blade, Tape	109868-1	1	3
Bracket, Punch Mounting	109861-1	1	4
Bracket, Punch Retaining	109866-1	1	5
Bracket, Punch Retaining	109866-2	1	6
Cable Assembly, <u>RDF3075BC1 Only</u>	110374-1	1	(P1,P3)
Connector, Cannon DB-25P	706500-231	1	P1
Connector, Housing, 15 Pin, Modified	109143	1	P3
Contact, Pin, Amp 61121-1LP	706530-131	1	(P3)
Cover, Connector, Cannon DB19678-2	706540-136	1	(P1)
Screw Lock Assembly, Male, Cannon D-20419-1	706540-124	1	(P1)
Chassis Assembly	110403-1	1	Ref.
Bracket, Connector Assembly	109805-1	1	(J1-J3)
Bracket, Connector Mounting	109807-1	1	
Capacitor, 2 x .01 uf, 125 VAC Dual Ceramic Sprague 36C219	702127-103	1	C2A/B
Connector, Cannon DB-25S	706510-211	1	J1
Connector, Amphenol 160-5	706500-104	1	J2
Connector, Amp 1-480423-0	706500-223	1	J3
Fuse, 2.5 Amp, 250V, Slow-Blow (100, 115 or 127 VAC Operation)	705710-124	1	F1
Fuse, 1.5 Amp, 250V, Slow-Blow (220, 240 VAC Operation)	705710-138	1	F1
Fuseholder, Littlefuse 342004	705750-100	1	(F1)
Screw Lock Assembly, Female, Cannon D-20418-2	706540-123	2	(J1)
Socket, Insert Contacts, Amp 61123-1LP	706530-132	12	(J3)
Bracket, Support	109443	1	7
Capacitor, 21 K uf, 40V, Electrolytic STM 71C40CC213	702313-104	1	C1
Chassis	109589-1	1	8
Clamp, Cable, Thomas/Betts TC-342A	715040-141	1	9
Connector, Housing, 12 pin, Amp 1-480409-0, White	706500-222	1	J4
Connector, Housing, 7 pin Amp 1-480421-0, White	706500-221	1	J5
Connector, Housing, 12 pin, Amp 1-480409-3, Orange	706500-229	1	J6
Connector, Housing, 7 pin, Amp 1-480421-4, Yellow	706500-226	1	J7
Connector, Housing, 7 pin, Amp 1-480421-6 Blue	706500-227	1	J8

NOTE: WHEN ORDERING SPARE PARTS, CONTACT REMEX SPARES ORDER DESK AND REFERENCE COMPLETE MODEL AND SERIAL NUMBER OF UNIT. ALWAYS REFER TO ADDENDUM (IF PRESENT) AT THE REAR OF THE MANUAL FOR POSSIBLE PART NUMBER CHANGES.

7.5 PARTS LIST RAF3075 AND RDF3075 (Continued)

Description and Manufacturer's Part No.	REMEX Part No.	Quantity	Reference Designation
Connector, P.C. Card, S.A.E. SAC 22D/1-2	706510-212	2	J10,J12
Connector, P.C. Card, S.A.E. SAC 22S/1-2	706510-204	3	J11,J13,J9
Contact, Connector, Socket, Amp 61123-1LP	706530-132	34	(J4-J8)
Decal, Fuse Value	109599-1	1	10
Diode, Zener 5.6V, 1N4561	704022-103	1	Z1
Heat Sink Assembly	110349-1	1	(Q1-Q3)
Diode, 1N5059 (or 1N4003)	704000-107	3	CR1-CR3
Heat Sink, Ierc EIC03-0655B	715033-117	1	(Q1-Q3)
Transistor, Motorola MJE1101	704204-119	3	Q1-Q3
Key, Polarizing, S.A.E. 007900	706540-134	5	(J10-J13)
Printed Circuit Card Assembly, Read Motor Amplifier	110011-1	1	PC1
Diode, 1N5059 (or 1N4003)	704000-107	3	CR1-CR3
Transistor, Motorola MJE1100	704204-115	3	Q1-Q3
Rectifier, Bridge, Motorola MDA962A-2	704005-130	1	BR1
Resistor, 2.5 ohm, 50W, 3%, Wirewound, Dale RH50-3%	701182-R50	1	R1
Resistor, 3 ohm, 5W	701016-3R0	1	R2
Shield, Transformer	109596-1	1	(T1)
Spacer, 1/4 dia x 1/8 long, NAS43-DD1-8	715030-102	2	12
Spacer, 5/16 long, Amatom 9225-A-0140-1B	715030-178	2	13
Spacer, 7/16 long, Amatom 9227-A-0140-1B	715030-179	2	14
Strap, Capacitor	109458	1	(C1)
Terminal Strip, 4 terminals, Cinch Jones 54B	715010-121	1	TB2
Transformer, REMEX Specification	703010-135	1	T1
Connector, Cannon DB-25P	706500-231	1	P1
Connector, Amp modifier	109143	1	P3
Connector, Housing, 7 pins, Amp 1-480408-0 White	706510-201	1	P5
Contacts, Connector Pin, Amp 61121-1LP	706530-131	5	(P5)
Cover, Chad Bin	109853-1	1	15
① Cover, Tape Tank, Lower	109245	2	16
① Cover, Tape Tank, Upper	109244-1	1	17
① Cover, Tape Tank, Upper	109244-2	1	18
Cover, Reader	109790-1	1	19
Decal, Caution	109890-1	1	20
Decal, Punch Lub	110338-1	1	21
Decal, Run/Load	109939-1	1	22
Deck Tape Supply, Fan Fold	109862-1	1	23
Front Panel Assembly RAF3075	110402-1	1	Ref.
Front Panel Assembly RDF3075	110379-1	1	Ref.
The subassemblies for 110402-1 and 110379-1 the same except as indicated:			
Cap, Rocker, Switch, POWER	715062-101	1	(S1)
Cap, Rocker, Switch, ← (RAD3075 Only)	715062-102	2	(S2,S3)
Cap, Rocker, Switch, DUP (RDF3075 Only)	715062-108	1	(S2)
Cap, Rocker, Switch, ↘ (RDF3075 Only)	715062-111	1	(S3)

① Later models replace these parts with items 59 and 60.

NOTE: WHEN ORDERING SPARE PARTS, CONTACT REMEX SPARES ORDER DESK AND REFERENCE COMPLETE MODEL AND SERIAL NUMBER OF UNIT. ALWAYS REFER TO ADDENDUM (IF PRESENT) AT THE REAR OF THE MANUAL FOR POSSIBLE PART NUMBER CHANGES.

7.5 PARTS LIST RAF3075 AND RDF3075 (Continued)

Description and Manufacturer's Part No.	REMEX Part No.	Quantity	Reference Designation
Cap, Rocker, Switch, LOAD	715062-103	1	(S4)
Cap, Rocker, Switch, FEED/DELETE	715062-110	1	(S5)
Capacitor, .1 uf, 200V (RDF3075 Only)	702128-104	1	C3
Clip, Retaining Lamp, Dialco 515-0051	715072-104	1	(DS1)
Connector, Housing, 12 pin Amp 1-480408-0, White	706510-202	1	P4
Connector, Housing, 12 pin, Amp 1-480408-3, Orange	706510-208	1	P6*
Connector, Housing, 7 pin, Amp 1-480420-6, Blue	706510-206	1	P8
Connector, Plug, Dialco 515-0050	706515-126	1	(DS1)
Contact, Pin, Amp 61121-1LP	706530-131	15	(P4,P6,P8)
Fastener, Pushbutton with retainer Southco 34-10-101-10	713656-122	2	24
Handle, Southco 25-11-101-13	714096-112	1	25
Heat Sink	109268-2	1	26
Lamp, Red, Indicating, 28V Dialco 507-3917-0331-600	715071-122	1	DS1
Light Source Assembly	109375	1	DS2
Logo	109782-1	1	27
Nut, Tinnerman, Push-On C637-012	713500-135	2	28
Panel, Front	110404-2	1	29
Post, Tape Guide	109497	1	30
Read Head Assembly - When replacing the sensor assembly order complete 109697-1 assembly. See Section 6.10. Also order P6 (706510-208) when ordering a new read head assembly. See Figure 7-1 for assembly.	109697-1	1	31
Mounting Block, Read Head	109695-1	1	
Sensor Photoelectric	109673-1	1	
Shaft, Lower Guide	109106	1	
Spacer, Read Head	109671-1	1	
Spring, Leaf	109794-1	1	
Spring, Torsion	109111	1	
Tape Guide, Lower	109796-1	1	
Tape Guide, Upper	109103	1	
Resistor, 100 ohm, 1/4 W	701003-101	5	R3-R7
Sprocket, REMEX Specification	716057-102	1	32
Step Motor Connector Assembly	109273	1	(M2,P7)
Connector, Amp 1-480420-4, Yellow	706510-205	1	P7
Motor, Stepper, IMC Magnetic, 28VDC	715075-158	1	M2
Pin, Connector, Amp 61121-1LP	706530-131	4	(P7)
Switch Assembly, RAF3075 Only	715061-156	2	(S1,S4)
Base Switch, Cutler Hammer SC2CX	715061-100	1	S1,S4
Bezel Black	715061-006	1	
Lamp, 28V, Cutler Hammer SW8FL-L1	715061-050	1	

* Must also be ordered when replacing the Read Head Assembly.

NOTE: WHEN ORDERING SPARE PARTS, CONTACT REMEX SPARES ORDER DESK AND REFERENCE COMPLETE MODEL AND SERIAL NUMBER OF UNIT. ALWAYS REFER TO ADDENDUM (IF PRESENT) AT THE REAR OF THE MANUAL FOR POSSIBLE PART NUMBER CHANGES.

7.5 PARTS LIST RAF3075 AND RDF3075 (Continued)

Description and Manufacturer's Part No.	REMEX Part No.	Quantity	Reference Designation
Switch Assembly, <u>RDF 3075 Only</u>	715061-156	3	(S1,S2,S4)
Base Switch, Cutler Hammer SC2CX	715061-100	1	S1,S2,S4
Bezel Black	715061-006	1	
Lamp, 28V, Cutler Hammer SW8FL-L1	715061-050	1	
Switch Assembly, <u>RAF3075 Only</u>	715061-256	2	(S2,S3)
Base Switch, Cutler Hammer SC2GX	715061-200	1	S2,S3
Bezel, Black	715061-006	1	
Lamp, 28V, Cutler Hammer SW8FL-L1	715061-050	1	
Switch Assembly, <u>RDF3075 Only</u>	715061-456	2	(S3,S5)
Base Switch, Cutler Hammer SC2JX	715061-400	1	S3,S5
Bezel, Black	715061-006	1	
Lamp, 28V, Cutler Hammer SW8FL-L1	715061-050	1	
Switch Assembly, <u>RAF3075 Only</u>	715061-456	1	(S5)
Base Switch, Cutler Hammer SC2JX	715061-400	1	S5
Bezel, Black	715061-006	1	
Lamp, 28V, Cutler Hammer SW8FL-L1	715061-050	1	
Tape Guide, Left	109496	1	33
Tape Guide, Right	109248	1	34
Guide	716053-147	2	35
Guide, Tape Feed	110003-1	1	36
Lever Assembly, RUN/LOAD	110284-1	1	Ref.
Bracket, Tape Release	110334-1	1	38
Handle, Small Parts Inc. 125A	715021-118	1	39
Lever, Tape Release	110369-1	1	40
Rod, Tape Release	110335-1	1	41
Spacer, 3/8 long x .187 O.D., NAS43 DDO-24	715030-111	1	42
Spacer, 0.094 long x .187 O.D., P.I.C. B5-10	715030-146	1	43
Spring, Lane Spring Co. 166-A-.75 LG	714090-121	1	44
Spring, Lee LC-038D-1	714090-126	1	45
Switch, Micro 311SM23-H4	715058-124	1	S6
Motor, Fan, Howard 1075-10-3038	715075-172	1	M3
Nameplate, Decal Identification	109595-1	1	46
Nameplate, Patents Pending	108547	1	47
Power Cord, 10 foot, Belden 17460-S	708000-020	1	P2
Printed Circuit Card Assembly, Control Logic and Feed Hole Driver (See Table 7-1 for assembly and dash number determination and Figure 7-12 for component location.)	110261-XX	1	48
Printed Circuit Card Assembly, Data Logic and Driver (See Table 7-2 for assembly and dash number determination and Figure 7-13 for component location.)	110251-X	1	49
Printed Circuit Card Assembly, Power Supply (See Table 7-3 for assembly and Figure 7-14 for component location).	109061-2	1	50
Printed Circuit Card Assembly, Step Motor Driver (See Table 7-4 for assembly and dash number determination and Figure 7-15 for component location.)	109891-6X1	1	51

NOTE: WHEN ORDERING SPARE PARTS, CONTACT REMEX SPARES ORDER DESK AND REFERENCE COMPLETE MODEL AND SERIAL NUMBER OF UNIT. ALWAYS REFER TO ADDENDUM (IF PRESENT) AT THE REAR OF THE MANUAL FOR POSSIBLE PART NUMBER CHANGES.

7.5 PARTS LIST RAF3075 AND RDF3075 (Continued)

Description and Manufacturer's Part No.	REMEX Part No.	Quantity	Reference Designation
Punch (See Punch Manual for assemblies.)	716070-103	1	52
Ring Retainer, Truarc 5133-14	715025-144	1	53
Shroud, Fan	110118-1	1	54
① Slide, Tape, Lower	109247	2	55
① Slide, Tape, Upper	109246	2	56
Spacer, NAS43 DDO-8, 3/16 O.D. x 1/8 long.	715030-138	2	57
Switch, Limit, Micro Switch 311SM778-H4	715058-126	1	57
Tag, Caution	109781-1	1	58
Tank, Tape, Left Hand	110576-2	1	59
Tank, Tape, Right Hand	110576-1	1	60
Tray Tape	109860-1	1	61
Tube, Angular Connector	716072-208	1	62

① Later models replace these parts with items 59 and 60.

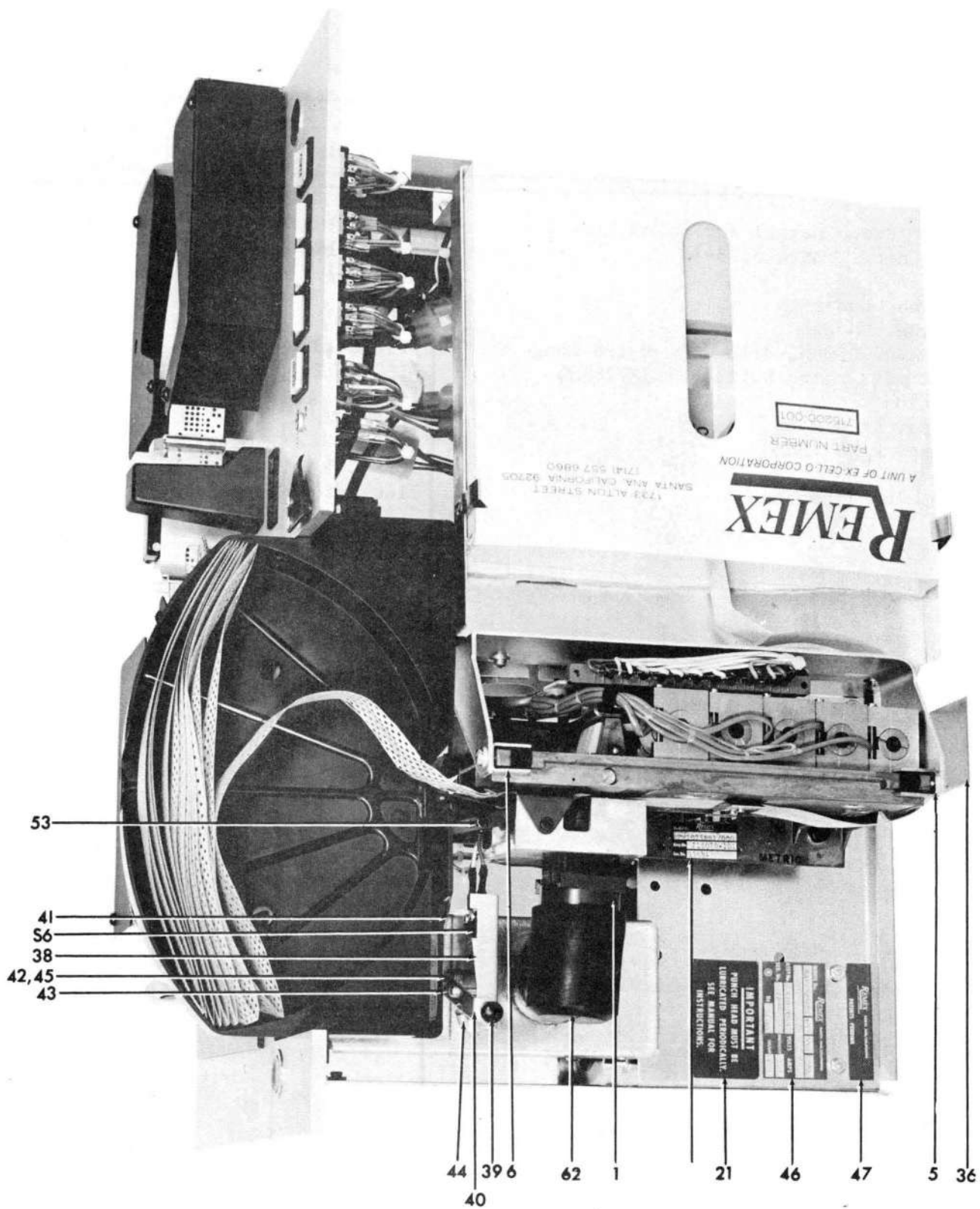

Figure 7-8. RAF3075BCX, Top View, Showing the Threading of the Tape

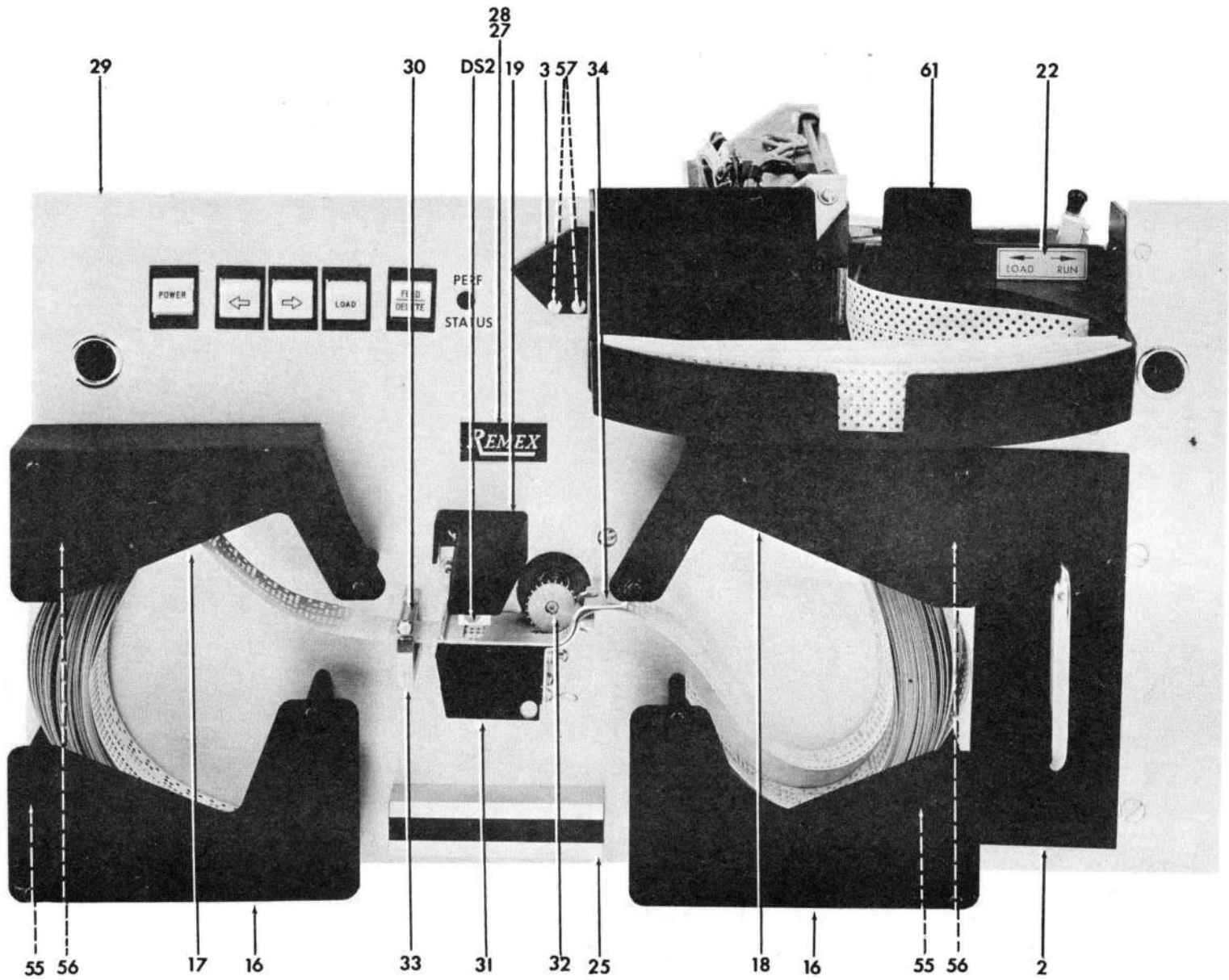

Figure 7-9. RAF3075BCX, Front View of Front Panel

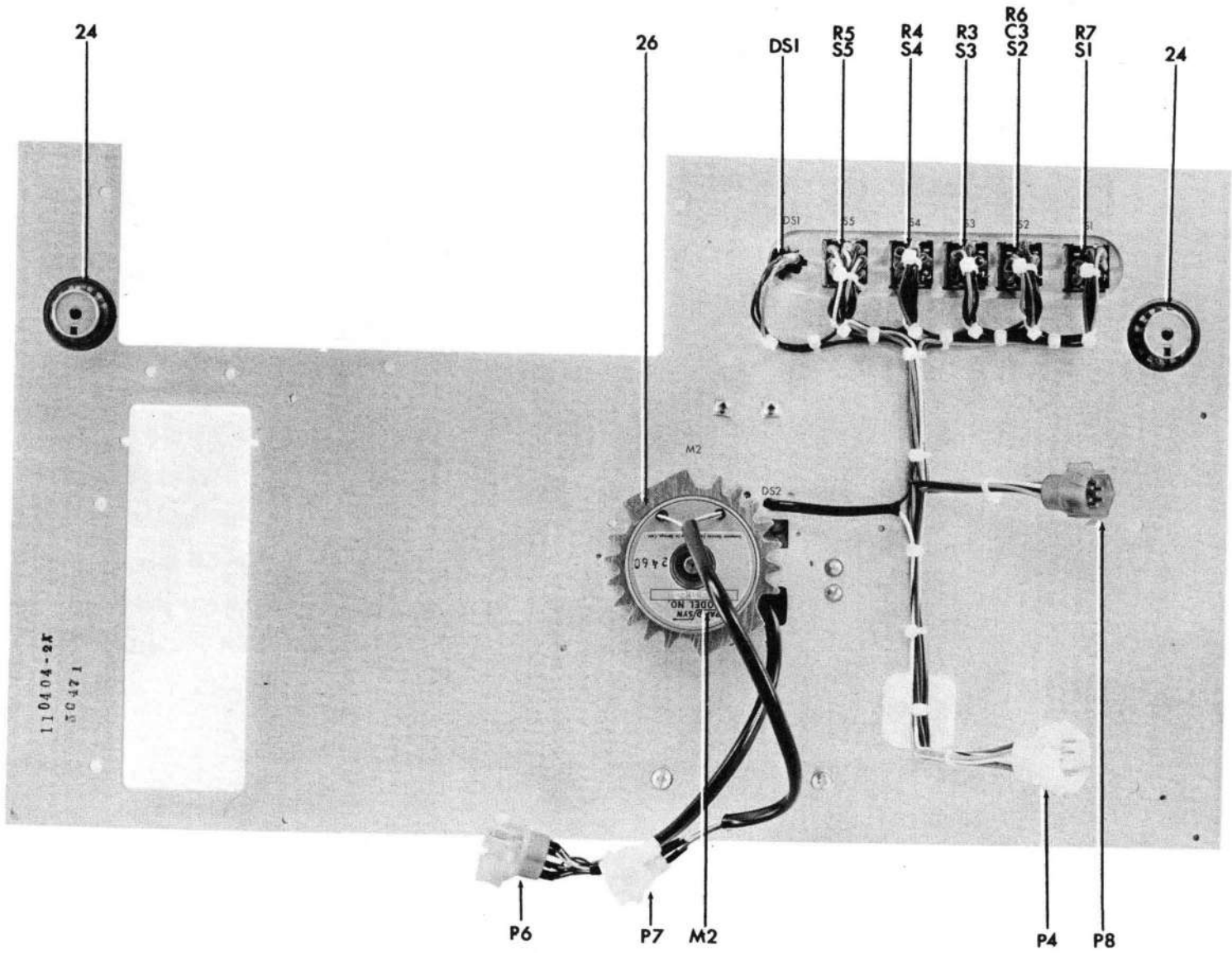

Figure 7-10. RAF3075BCX, Rear View of Front Panel

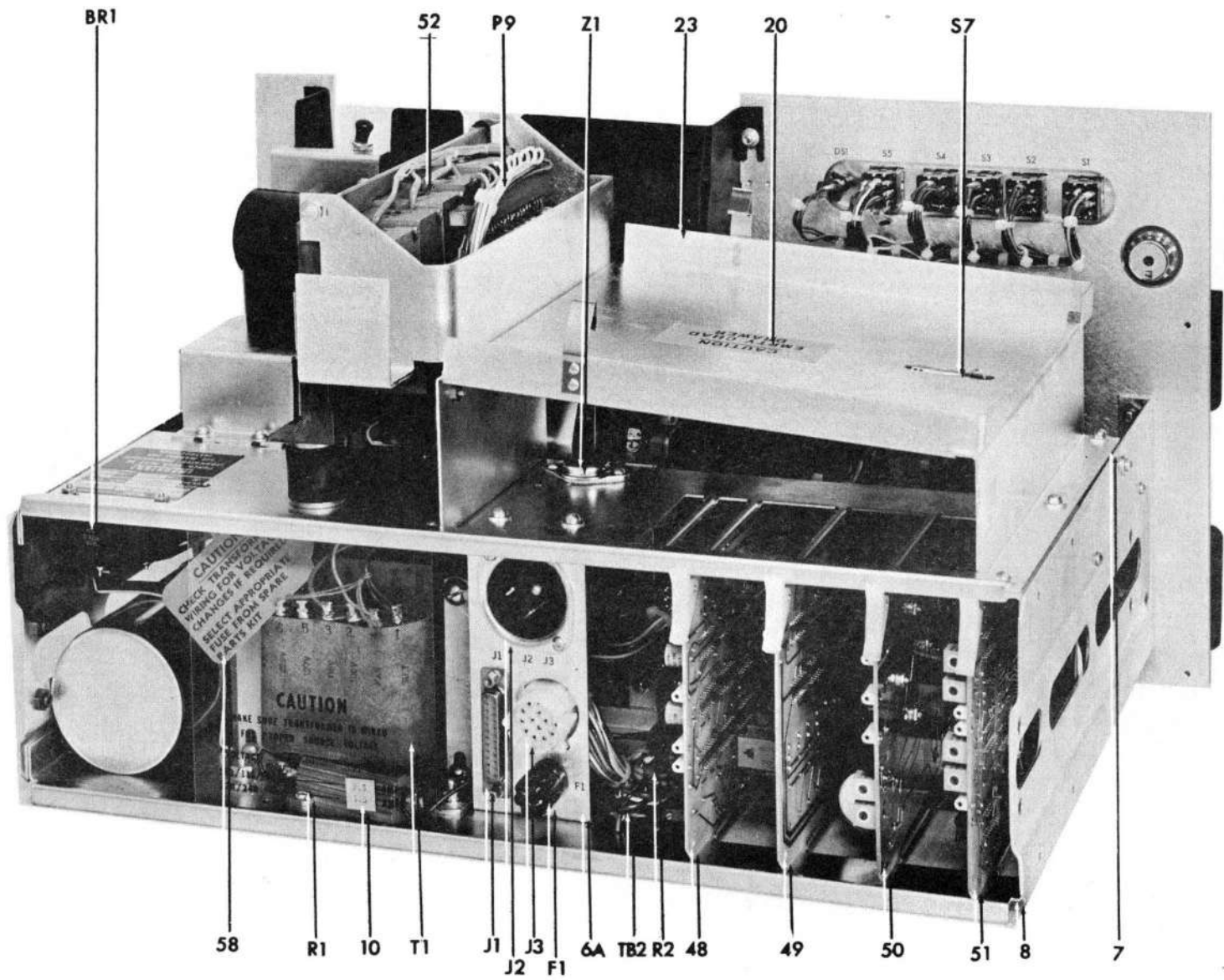

Figure 7-11. RAF3075BCX, Rear View

NOTE: WHEN ORDERING SPARE PARTS, CONTACT REMEX SPARES ORDER DESK AND REFERENCE COMPLETE MODEL AND SERIAL NUMBER OF UNIT. ALWAYS REFER TO ADDENDUM (IF PRESENT) AT THE REAR OF THE MANUAL FOR POSSIBLE PART NUMBER CHANGES

7.6 PARTS LIST, OPTIONS

Description and Manufacturer's Part No.	REMEX Part No.	Quantity	Reference Designation
Chassis Slide Assembly, 12 inch with mounting plates, 1/2" width	109600-1	1	OP1
Mounting Plate, Chassis Slide	109597-1	2	
Slide, Chassis, Grant 4930-12-FD	716025-113	2	
Chassis Slide Assembly, 12 inch with mounting plates and brackets, 1/2" width	110305-1	1	OP1
Bracket, Chassis Slide	109847-1	2	
Bracket, Chassis Slide	109847-2	2	
Mounting Plate, Chassis Slide	109597-1	2	
Slide, Chassis, Grant 4930-12-FD	716025-113	2	
Chassis Slide Assembly, 22 inch with mounting plates, 1/2" width	109601-1	1	OP1
Mounting Plate, Chassis Slide	109597-2	2	
Slide, Chassis, Grant 4930-22-FD	716025-114	2	
Chassis Slide Assembly, 22 inch with mounting plates and brackets, 1/2" width	109602-1	1	OP1
Bracket, Chassis Slide	109847-1	2	
Bracket, Chassis Slide	109847-2	2	
Mounting Plate, Chassis Slide	109597-2	2	
Slide, Chassis, Grant 4930-22-FD	716025-114	2	
Chassis Slide Assembly, 22 inch with mounting plates and brackets, 3/8" width	110345-1	1	OP1
Plate, Mounting	109597-2	2	
Slides, with brackets, pair	716025-116	1	
Chad Detector Assembly	110394-1	1	
<u>Delete</u> Chad Chute 109442-1			
<u>Add</u> the following items:			
Button	715065-114	1	OP2
Cardholder	110346-1	1	OP3
Chad Chute	109442-2	1	OP4
Clip, Retaining Lamp, Dialco 515-0051	715072-104	1	(DS8)
Connector, Plug, Dialco 515-0050	706515-126	1	(DS5)
Decal, RESET	110290-1	1	(S9)
Lamp, Indicating, Red, 28V, Dialco 507-3917-0331-600	715071-122	1	DS5
Printed Circuit Card, Chad Detector (see Table 7-4 for assembly and Figure 7-17 for component location.)	110291-1	1	OP5
Switch, Pushbutton	715059-180	1	S9
Terminal Board	110294-2	1	OP6
Transistor, Photo Amplifier 2N5779	704214-001	1	Q5
Enclosure, Desk Top RPR1075BCX	110418-1	1	
Enclosure, Desk Top RPS1075BCX/XXX/H--	110418-2	1	
Enclosure, Desk Top RPF1075BCX	110418-3	1	
Enclosure, Desk Top RPS1075BCX/XXX/A--	110418-4	1	

NOTE: WHEN ORDERING SPARE PARTS, CONTACT REMEX SPARES ORDER DESK AND REFERENCE COMPLETE MODEL AND SERIAL NUMBER OF UNIT. ALWAYS REFER TO ADDENDUM (IF PRESENT) AT THE REAR OF THE MANUAL FOR POSSIBLE PART NUMBER CHANGES.

Table 7-1. Control Logic and Feed Hole Driver Card 110261-XX* Assembly

Description and Manufacturer's Part No.	REMEX Part No.	Quantity	Reference Designation
Capacitor, 1 uf, 25V, Ceramic, Monolithic Sprague 5C	702130-105	2	C1, C2
Capacitor, 0.0047 uf, 200V, Ceramic, Type CK05	702128-472	2	C3,C8
Capacitor, 0.0022 uf, 200V, Ceramic, Type CK05	702128-222	1	C4
Capacitor, 0.001 uf, 200V, Ceramic, Type CK05	702128-102	1	C5
Capacitor, 330 uf, 6V, Electrolyte Tantalum Mallory TAS337M006P1	702384-337	1	C6
Capacitor, 0.01 uf, 100V, Metallized Mylar, IMB XA2B-103K	702191-103	1	C7
Capacitor, 1 uf, 100V, Metallized Mylar, Electrocube 217A1B105K	702181-105	1	C9
Capacitor, 0.47 uf, 100V, Metallized Mylar, Electrocube 217A1B474K	702181-474	1	C10
Capacitor, 0.1 uf, 100V, Metallized Mylar, Electrocube 217A1B104K	702181-104	1	C11
Diode, Fairchild FD6666	704000-110	1	CR1
Diode, 1N5059 (or 1N4003)	704000-107	1	CR2
Diode, Zener, Motorola, 1N5241B, 11V	704010-119	3	CR3-CR5
Ejector, Scanbe S202 with roll pin	716053-105	1	
I.C. Package, SN74121N	704610-115	3	Z1,Z5,Z9
I.C. Package, SN7400N	704600-101	2	Z2,Z4
I.C. Package, SN74107N	704610-117	1	Z3
I.C. Package, SN7408N	704600-114	1	Z6
I.C. Package, SN7486N	704600-109	1	Z7
I.C. Package, SN7404N	704600-110	1	Z8
I.C. Package, SN7432N	704600-126	2	Z10,Z12
I.C. Package, SN7416N	704600-113	1	Z11
I.C. Package, KD406, R-C Network	701950-001	2	Z13,Z14
Potentiometer, 50K, Spectrol 53-1-1-503	701659-503	2	R11,R13
Potentiometer, 50K Spectrol 41-2-2-503	701681-503	1	R15
Resistor, 0.5 ohm, 3 W, $\pm 5\%$	701015-R50	2	R1,R2
Resistor, 22 ohm, 1/4 W, $\pm 5\%$	701003-220	1	R3
Resistor, 2.2K, 1/4 W, $\pm 5\%$	701003-222	7	R4-R6,R8 R10,R12,R14
Resistor, 4.7K, 1/4 W, $\pm 5\%$	701003-472	1	R7
Resistor, 3.3K, 1/4 W, $\pm 5\%$	701003-332	1	R9
Resistor, 10K, 1/4 W, $\pm 5\%$	701003-103	1	R16
Resistor, 1K, 1/4 W, $\pm 5\%$	701003-102	2	R17,R18
Resistor, 1.5K, 2 W, $\pm 5\%$	701014-152	3	R19-R21
Test Point, White, Ucinite	715078-111	4	TP1-TP4
Test Point, Black, Ucinite	715078-112	1	TP5
Transistor, 2N4403	704202-108	1	Q1
Transistor, MJE 1100	704204-115	1	Q2

NOTE: When ordering spare parts, contact Remex Spares Order Desk and reference complete model and serial number of unit. Always refer to addendum (if present) at the rear of the manual for possible part number changes.

Table 7-1. Control Logic and Feed Hole Driver Card 110261-XX* Assembly (Continued)

*Card dash number is determined by output mode and circuit options as follows:

Model	Card Assembly No.
RXX3075BCX/X50/XXX	110261-50
RXX1075BCX/X51/XXX	110261-51
RXX1075BCX/X60/XXX	110261-60
RXX1075BCX/X61/XXX	110261-61

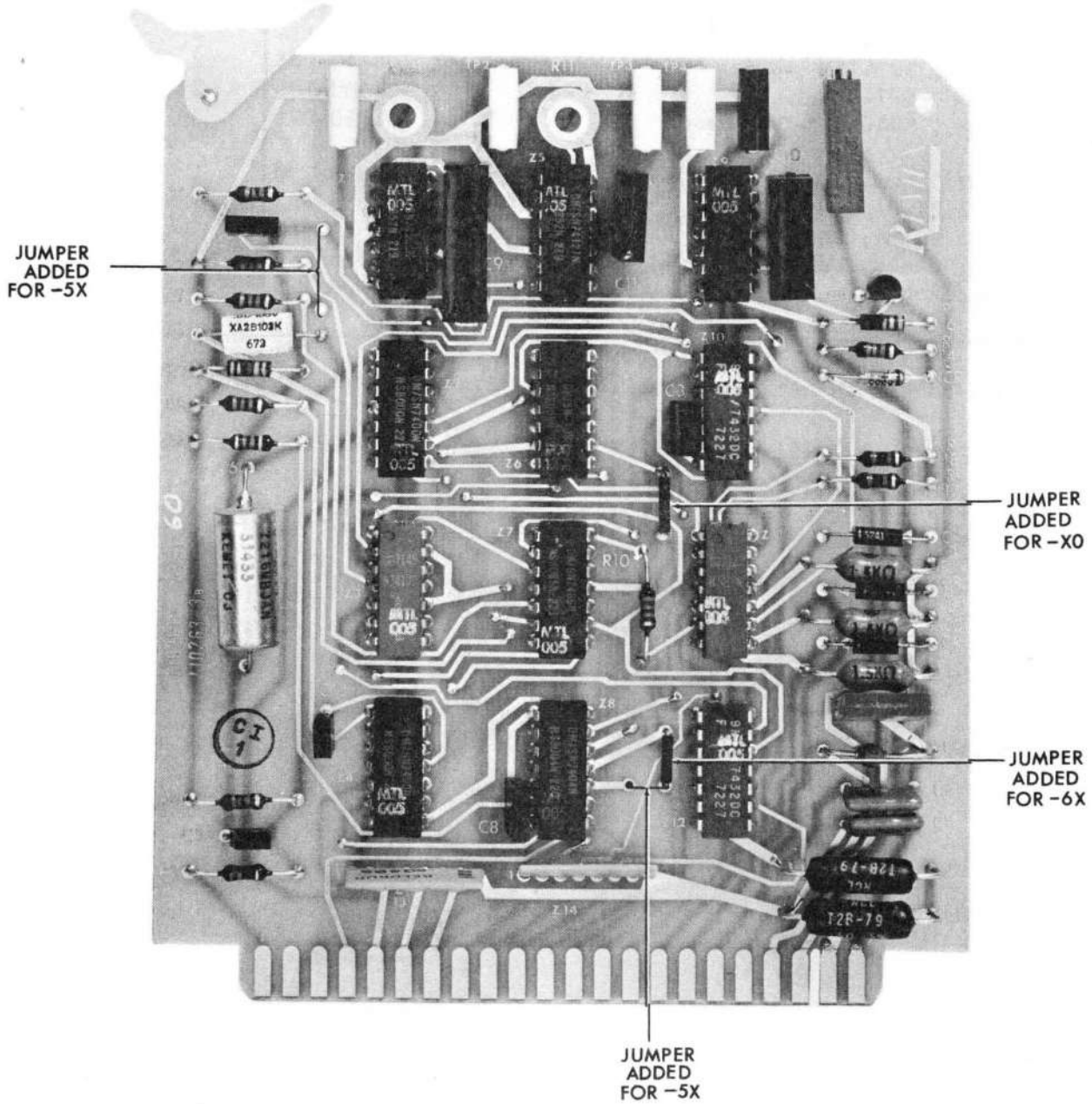

Figure 7-13. Control Logic and Feed Hole Driver Card 110261-60 Assembly

NOTE: WHEN ORDERING SPARE PARTS, CONTACT REMEX SPARES ORDER DESK AND REFERENCE COMPLETE MODEL AND SERIAL NUMBER OF UNIT. ALWAYS REFER TO ADDENDUM (IF PRESENT) AT THE REAR OF THE MANUAL FOR POSSIBLE PART NUMBER CHANGES.

Table 7-2. Data Logic Card 110251-X* Assembly

Description and Manufacturer's Part No.	REMEX Part No.	Quantity	Reference Designation
Capacitor, 1 uf, 25V, Ceramic, Monolithic Sprague 5C	702130-105	1	C1
Diode, 1N5059 (or 1N4003)	704000-107	8	CR1-CR8
Ejector, Scanbe S202 with roll pin	716053-105	1	
I.C. Package, SN7402N	704600-106	2	Z1,Z5
I.C. Package, SN7408N	704600-114	2	Z2,Z6
I.C. Package, SN7475N	704610-105	2	Z3,Z7
I.C. Package, SN7486N	704600-109	2	Z4,Z8
I.C. Package, KD406, R-C Network	701950-001	3	Z9,Z10, Z11
Resistor, 0.5 ohm, 3 W, +5%	701015-R50	1	R1
Resistor, 2.2K, 1/4 W, +5%	701003-222	1	R2
Test Point, White, Ucinite	715078-111	2	TP1,TP2
Test Point, Black, Ucinite	715078-112	1	TP3
Transistor, Motorola MJE 1100	704204-115	8	Q1-Q8

*Card dash number is determined by the input mode as follows:

<u>Model</u>	<u>Card Assembly No.</u>
RXX3075BCX/ <u>5</u> XX	110251- <u>5</u>
RXX3075BCX/ <u>6</u> XX	110251- <u>6</u>

NOTE: All RDB3075 and RDF3075 units must use the 110251-5 card.

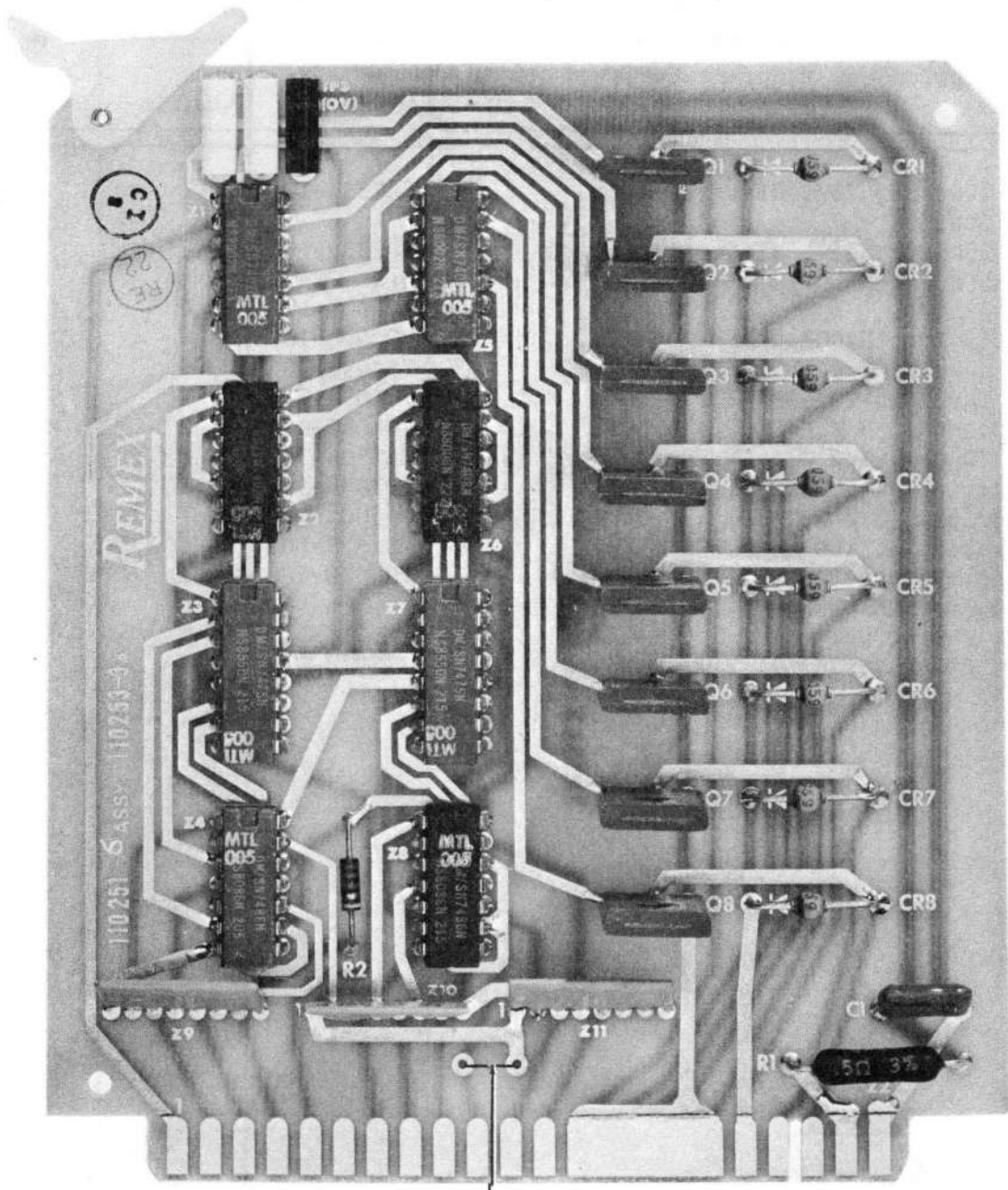

JUMPER
ADDED
FOR -5

Figure 7-14. Data Logic and Driver Card 110251-6 Assembly.

NOTE: WHEN ORDERING SPARE PARTS, CONTACT REMEX SPARES ORDER DESK AND REFERENCE COMPLETE MODEL AND SERIAL NUMBER OF UNIT. ALWAYS REFER TO ADDENDUM (IF PRESENT) AT THE REAR OF THE MANUAL FOR POSSIBLE PART NUMBER CHANGES.

Table 7-3. Step Motor Power Supply Card 109061-2 Assembly

Description and Manufacturer's Part No.	REMEX Part No.	Quantity	Reference Designation
Capacitor, 1000 uf, 75V, Electrolytic STM 61C75TS13	702351-101	1	C1
Capacitor, 3500 uf, 25V, Electrolytic, STM 61C25TA352	702359-101	1	C2
Diode, MR1032B	704005-117	2	CR1-CR2
Diode, 1N5059 (or 1N4003)	704000-107	4	CR3-CR5,CR7
Ejector, Scanbe S202 with roll pin	716053-105	1	
Heat Sink, Ierc HP3-T03-4B	715033-114	1	(A1)
Resistor, 0.5 ohm, 3 W, +5%	701015-R50	2	R1,R2
Resistor, 330 ohm, 1/2 W	701004-331	1	R3
Resistor, Variable, 50 ohm, 1/2 W	701658-500	1	R4
Resistor, 47 ohm, 1/2 W, +5%	701004-470	1	R5
Resistor, Variable, 100 ohm, 1/2 W	701658-101	1	R6
I.C. Package, Voltage Regulator, National Semiconductor LM309K	704520-109	1	A1
Test Point, White, Ucinite	715078-111	3	TP1-TP3
Test Point, Black, Ucinite	715078-112	1	TP4

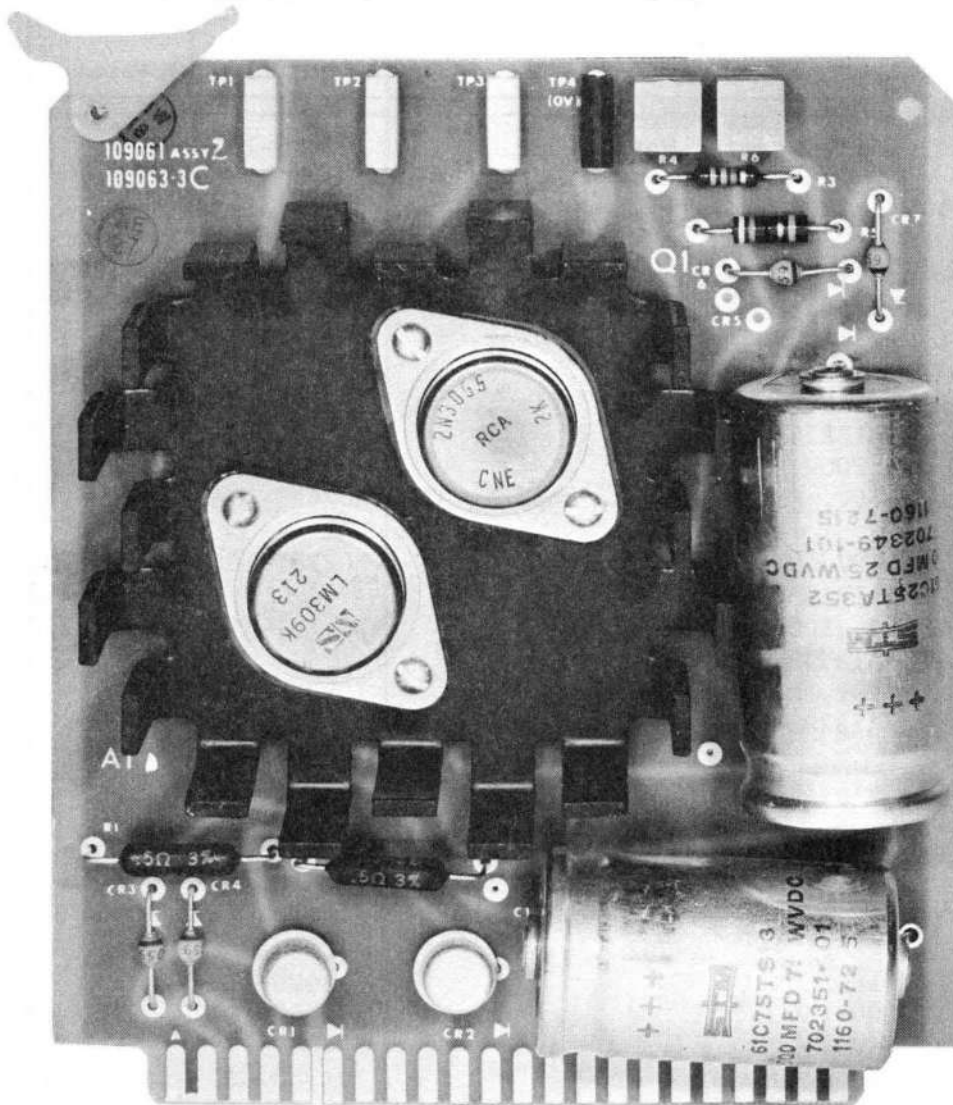

Figure 7-15. Step Motor Power Supply Card 109061-2 Assembly.

NOTE: WHEN ORDERING SPARE PARTS, CONTACT REMEX SPARES ORDER DESK AND REFERENCE COMPLETE MODEL AND SERIAL NUMBER OF UNIT. ALWAYS REFER TO ADDENDUM (IF PRESENT) AT THE REAR OF THE MANUAL FOR POSSIBLE PART NUMBER CHANGES.

Table 7-4. Step Motor Driver Card 109891-6X1 Assembly.

Description and Manufacturer's Part No.	REMEX Part No.	Quantity	Reference Designation
Capacitor, 1 uf, 25V, Ceramic, Monolithic Sprague 5C	702130-105	3	C1-C3
Capacitor, 0.01 uf, 100V, Metallized Mylar, IMB XA2B-103K	702191-103	1	C4
Capacitor, 0.33 uf, 100V, Metallized Mylar, Electrocube 217A1B334K	702181-334	1	C5
Capacitor, 0.001 uf, 100V, Metallized Mylar, IMB XA2B-102K	702191-102	3	C6,C7,C14
Capacitor, 0.22 uf, 100V, Metallized Mylar, Electrocube 217A1B224K	702181-224	1	C8
Capacitor, 100 pf, 200V, Ceramic	702128-101	1	C9
Capacitor, 47 uf, 10V, Electrolytic, Amperex Model ET	702620-476	1	C10
Capacitor, 1 uf, 100V, Metallized Mylar, Electrocube 217A1B105K	702181-105	1	C11
Capacitor, 0.033 uf, 100V, Metallized Mylar, Electrocube 217A1B333K	702181-333	1	C12
Capacitor, 2 uf, 100V, Metallized Mylar, Electrocube 217A1B205K	702181-205	1	C13
Diode, IN276	704000-100	3	CR1-CR3
Ejector with roll pin, Scanbe S202	716053-105	1	
I.C. Package, SN7475N	704610-105	2	Z1,Z11
I.C. Package, SN7403N	704600-112	1	Z2
I.C. Package, SN74107N	704610-117	1	Z3
I.C. Package, SN74123N	704610-119	3	Z4,Z10,Z17
I.C. Package, Resistor, KD404A-202	701900-001	2	Z5,Z14
I.C. Package, SN7416N	704600-113	2	Z6,Z15
I.C. Package, SN7400N	704600-101	2	Z7,Z13
I.C. Package, SN7486N	704600-109	1	Z8
I.C. Package, Resistor/Capacitor KD406	701950-001	1	Z9
I.C. Package, SN7474N	704610-110	1	Z12
I.C. Package, SN7408N	704600-114	1	Z16
Potentiometer, 20 K, 1/2 W, Spectrol 53-2-1-203	701658-203	2	R8,R12
Potentiometer, 50 K, 1/2 W, Spectrol 53-2-1-503	701658-503	2	R13,R15
Resistor, 22 ohm, 1/4 W, +5%	701003-220	3	R1,R2,R14
Resistor, 2.2 K, 1/4 W, +5%	701003-222	5	R3,R6,R9, R20,R21
Resistor, 220 ohm, 1/4 W, +5%	701003-221	2	R4,R5
Resistor, 4.7 K, 1/4 W, +5%	701003-472	2	R7,R11
Resistor, 47 ohm, 1/4 W, +5%	701003-470	1	R10
Resistor, 47 K, 1/4 W, +5%	701003-473	1	R16
Resistor, 330 ohm, 1/4 W, +5%	701003-331	3	R17-R19
Test Point, White, Ucinite	715078-111	3	TP1,TP2,TP3
Test Point, Black, Ucinite	715078-112	1	TP4

Dash Number Determination

Reader Input Mode	Reader Output Mode	Additional Options
6 = Mode 6	5 = Mode 5	1 - None
	6 = Mode 6	

109891-	6	X	1
---------	---	---	---

Jumper Wiring for Output Mode 5 or 6

From	To	
	Output Mode 5	Output Mode 6
UU	VV	TT
WW	BB	AA
XX	DD	CC
YY	FF	EE
ZZ	HH	GG
<u>AA</u>	KK	JJ
<u>BB</u>	MM	LL
<u>CC</u>	PP	NN
<u>DD</u>	SS	RR

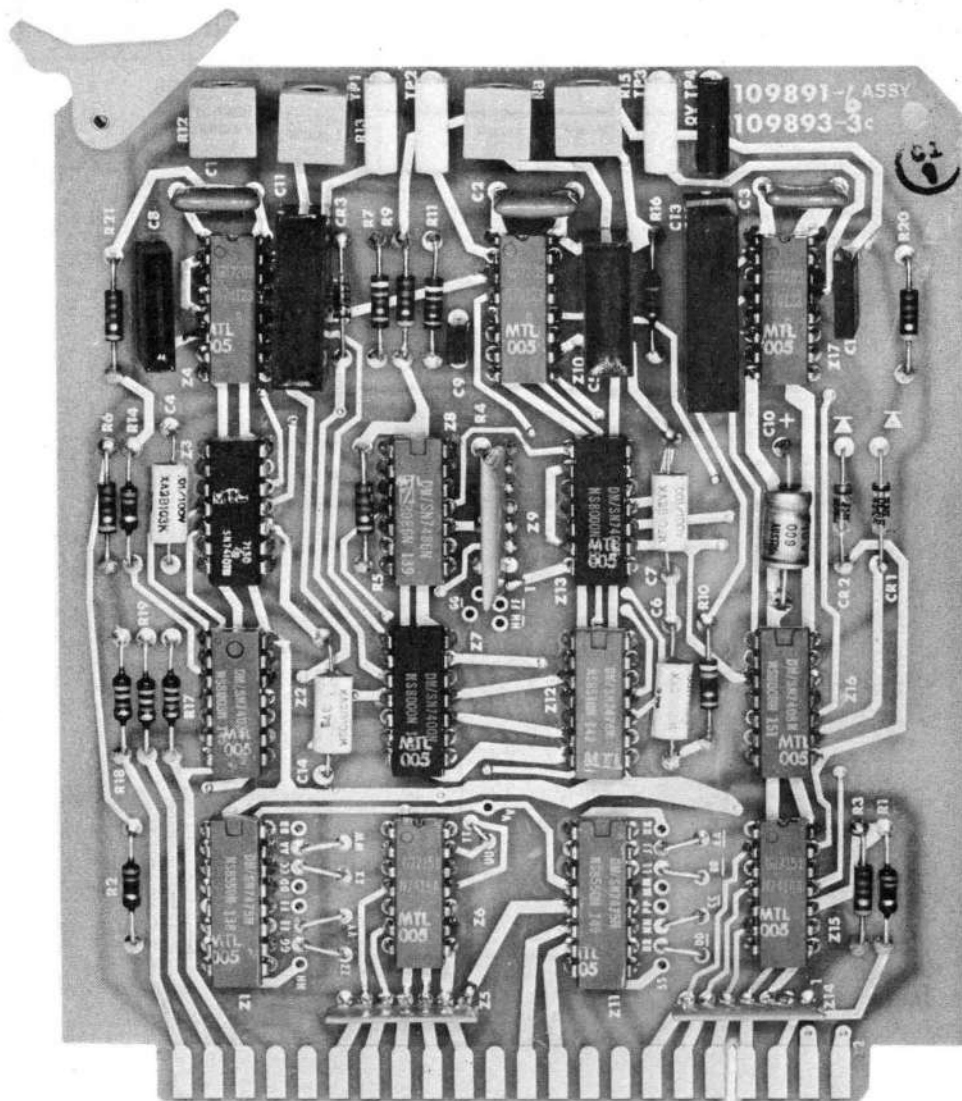

Figure 7-16. Step Motor Driver Card 109891-660 Assembly.

NOTE: WHEN ORDERING SPARE PARTS, CONTACT REMEX SPARES ORDER DESK AND REFERENCE COMPLETE MODEL AND SERIAL NUMBER OF UNIT. ALWAYS REFER TO ADDENDUM (IF PRESNET) AT THE REAR OF THE MANUAL FOR POSSIBLE PART NUMBER CHANGES.

Table 7-5. Optional Chad Detector Card 110291-1 Assembly

Description and Manufacturer's Part No.	REMEX Part No.	Quantity	Reference Designation
Capacitor, 100 uf, 10V, Solid Tantalum, Kemet T360	702393-107	1	C1
Capacitor, 15 uf, 10V, Solid Tantalum, Kemet T360	702393-156	1	C2
Diode, Fairchild FD6666	704000-110	3	CR1-CR3
I.C. Package SN7403N	704600-112	1	Z1
Resistor, 2.2K, 1/4 W, $\pm 5\%$	701003-222	5	R1, R5-R8
Resistor, 200 ohm, 1/4 W, $\pm 5\%$	701003-201	1	R2
Resistor, 4.7K, 1/4 W, $\pm 5\%$	701003-472	1	R3
Resistor, 10K, 1/4 W, $\pm 5\%$	701003-103	1	R4
Resistor, 3.3K, 1/4 W, $\pm 5\%$	701003-332	1	R9
Transistor, 2N4401	704203-114	2	Q1, Q2

(NOT AVAILABLE AT TIME OF PRINTING.
SEE FIGURE 8-10.)

Figure 7-17. Optional Chad Detector Card 110291-1 Assembly.

SECTION VIII

DRAWINGS

8.1 GENERAL

Figures 8-1 through 8-16 contain the schematics of the RAB3075BCX, RAF3075BCX, RDB3075BCX and RDF3075BCX units and their circuit cards. All IC Module outlines and truth tables are reproduced courtesy of Texas Instruments except for the LM300, LM307 and LM309 which are reproduced courtesy of National Semiconductor.

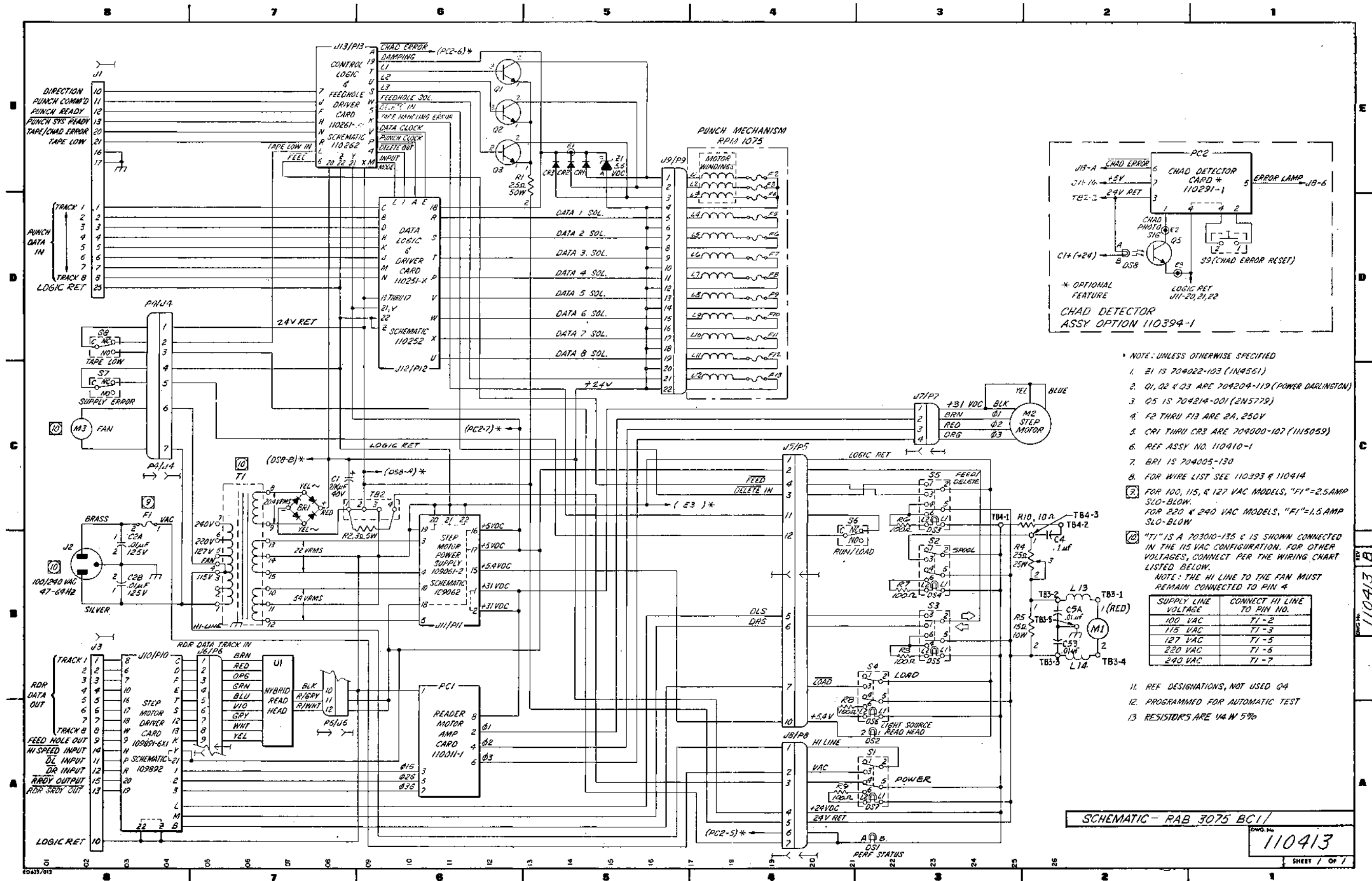

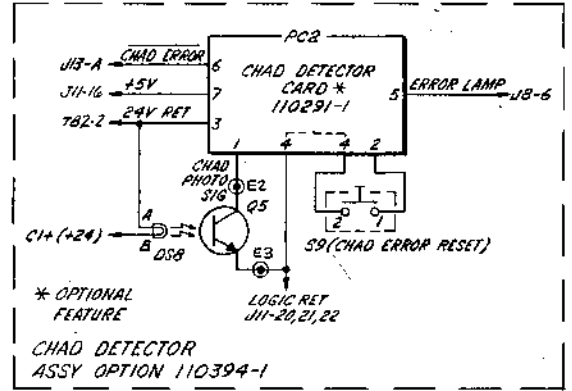
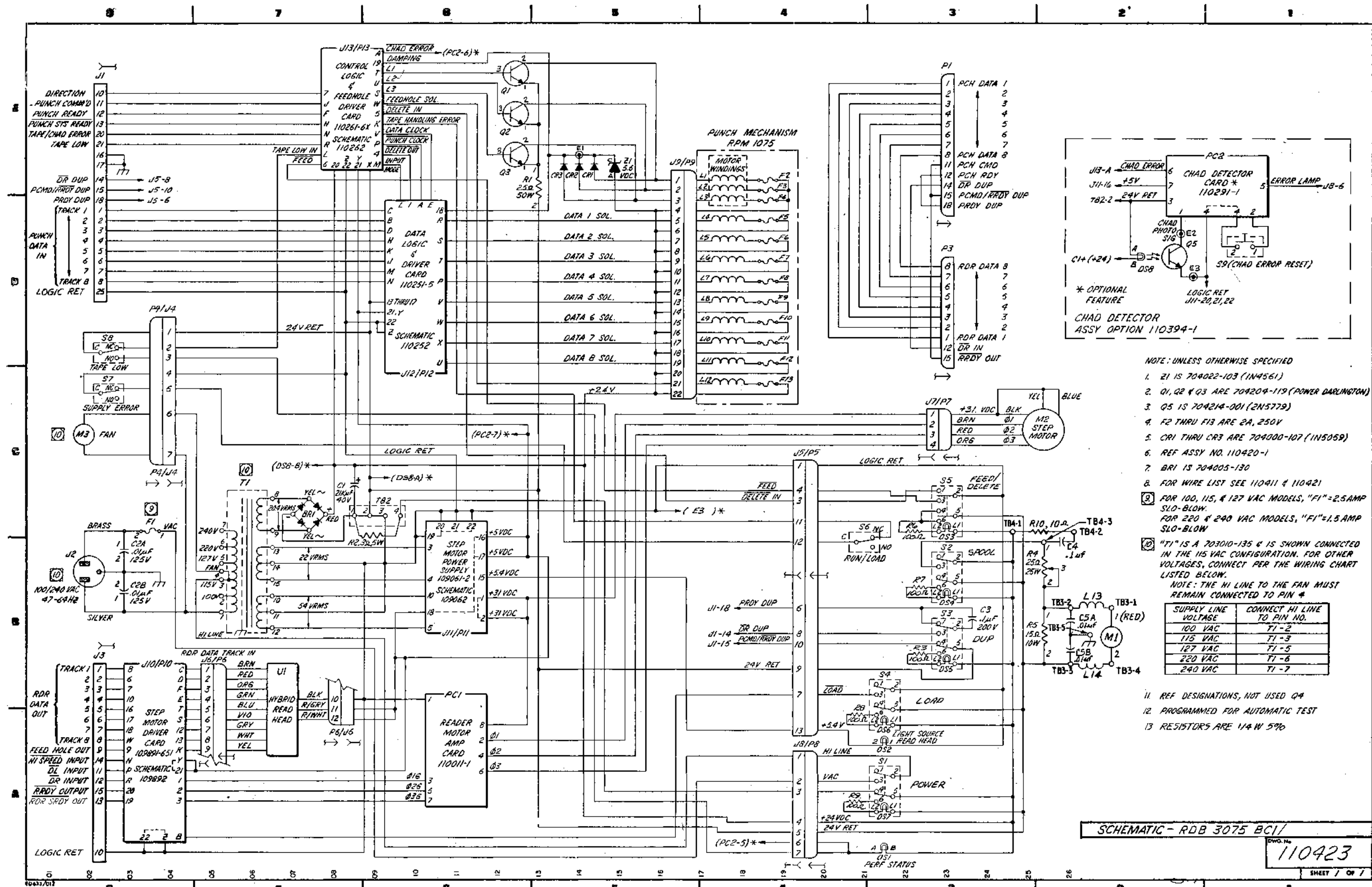

- NOTE: UNLESS OTHERWISE SPECIFIED
1. Z1 IS 704022-103 (1N4561)
 2. Q1, Q2 & Q3 ARE 704204-119 (POWER DARLINGTON)
 3. Q5 IS 704214-001 (2N5779)
 4. F2 THRU F13 ARE 2A, 250V
 5. CR1 THRU CR3 ARE 704000-107 (1N5059)
 6. REF ASSY NO. 110420-1
 7. BR1 IS 704005-130
 8. FOR WIRE LIST SEE 110411 & 110421
 9. FOR 100, 115, & 127 VAC MODELS, "FI" = 2.5 AMP SLO-BLOW. FOR 220 & 240 VAC MODELS, "FI" = 1.5 AMP SLO-BLOW
 10. "T1" IS A 703010-135 & IS SHOWN CONNECTED IN THE 115 VAC CONFIGURATION. FOR OTHER VOLTAGES, CONNECT PER THE WIRING CHART LISTED BELOW.
- NOTE: THE HI LINE TO THE FAN MUST REMAIN CONNECTED TO PIN #
- | SUPPLY LINE VOLTAGE | CONNECT HI LINE TO PIN NO. |
|---------------------|----------------------------|
| 100 VAC | T1-2 |
| 115 VAC | T1-3 |
| 127 VAC | T1-5 |
| 220 VAC | T1-6 |
| 240 VAC | T1-7 |
11. REF DESIGNATIONS, NOT USED Q4
 12. PROGRAMMED FOR AUTOMATIC TEST
 13. RESISTORS ARE 1/4 W 5%

SCHEMATIC - RDB 3075 BCI / 110423

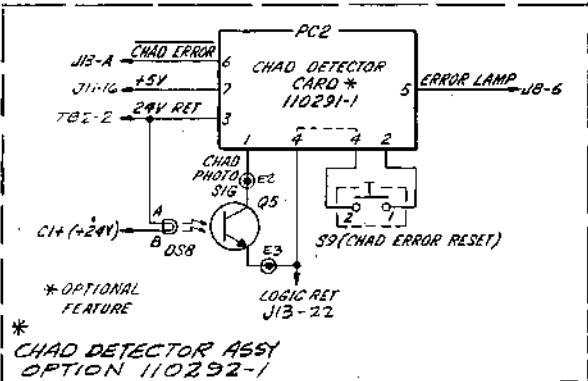
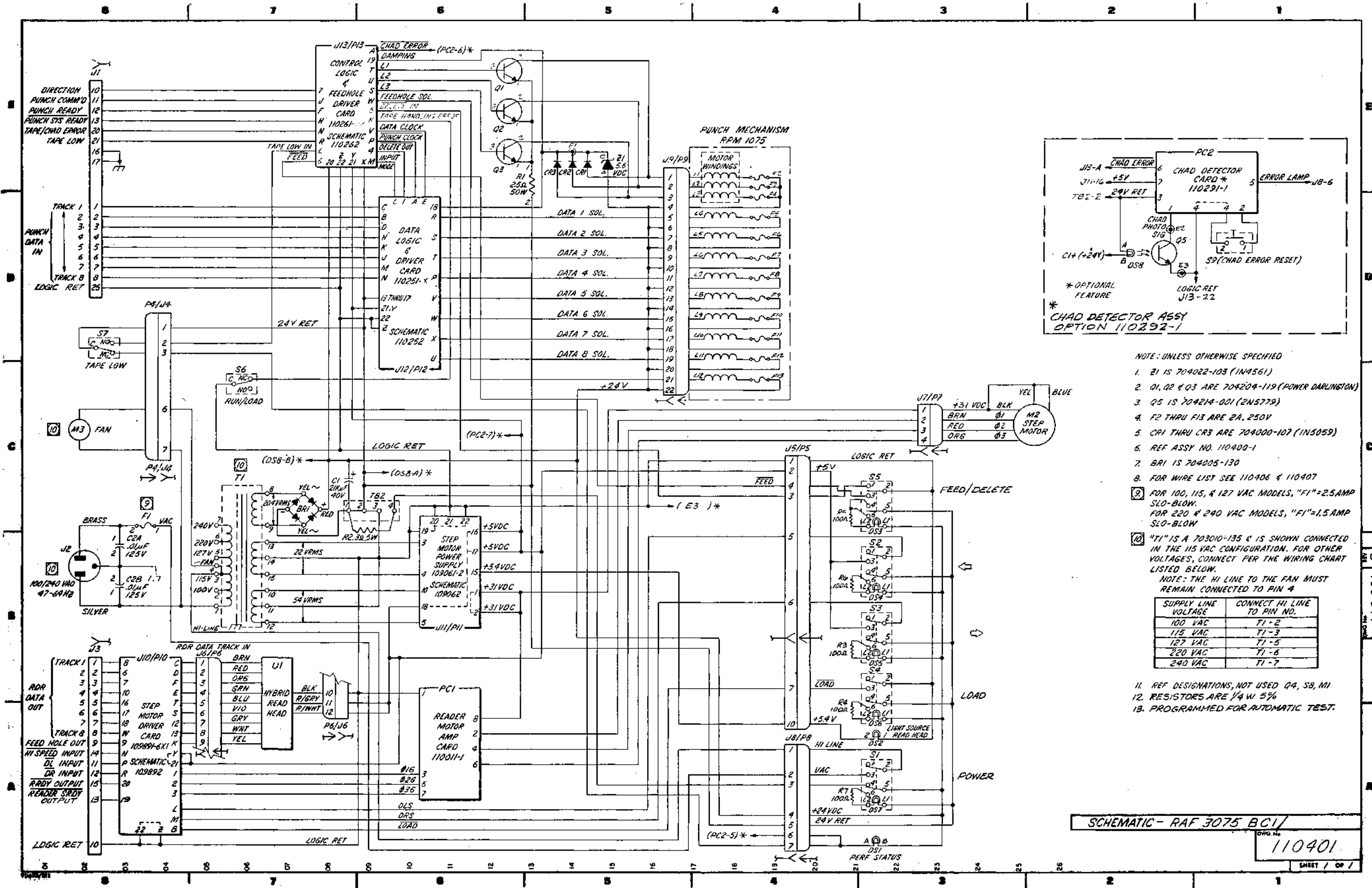

- NOTE: UNLESS OTHERWISE SPECIFIED
- E1 IS 704022-103 (1N4561)
 - Q1, Q2 & Q3 ARE 704204-119 (POWER DARLINGTON)
 - Q5 IS 704214-001 (2N5779)
 - F2 THRU F13 ARE 2A, 250V
 - CRI THRU CR3 ARE 704000-107 (1N5059)
 - REF ASSY NO. 110400-1
 - BR1 IS 704005-130
 - FOR WIRE LIST SEE 110406 & 110407
 - FOR 100, 115, & 127 VAC MODELS, "F1"=2.5 AMP SLO-BLOW. FOR 220 & 240 VAC MODELS, "F1"=1.5 AMP SLO-BLOW
 - "T1" IS A 703010-135 & IS SHOWN CONNECTED IN THE 115 VAC CONFIGURATION. FOR OTHER VOLTAGES, CONNECT PER THE WIRING CHART LISTED BELOW.
- NOTE: THE HI LINE TO THE FAN MUST REMAIN CONNECTED TO PIN 4
- | SUPPLY LINE VOLTAGE | CONNECT HI LINE TO PIN NO. |
|---------------------|----------------------------|
| 100 VAC | T1-2 |
| 115 VAC | T1-3 |
| 127 VAC | T1-5 |
| 220 VAC | T1-6 |
| 240 VAC | T1-7 |
- REF DESIGNATIONS, NOT USED Q4, S8, M1
 - RESISTORS ARE 1/4 W 5%
 - PROGRAMMED FOR AUTOMATIC TEST.

SCHEMATIC - RAF 3075 BC1/ 110401 SHEET 1 OF 1

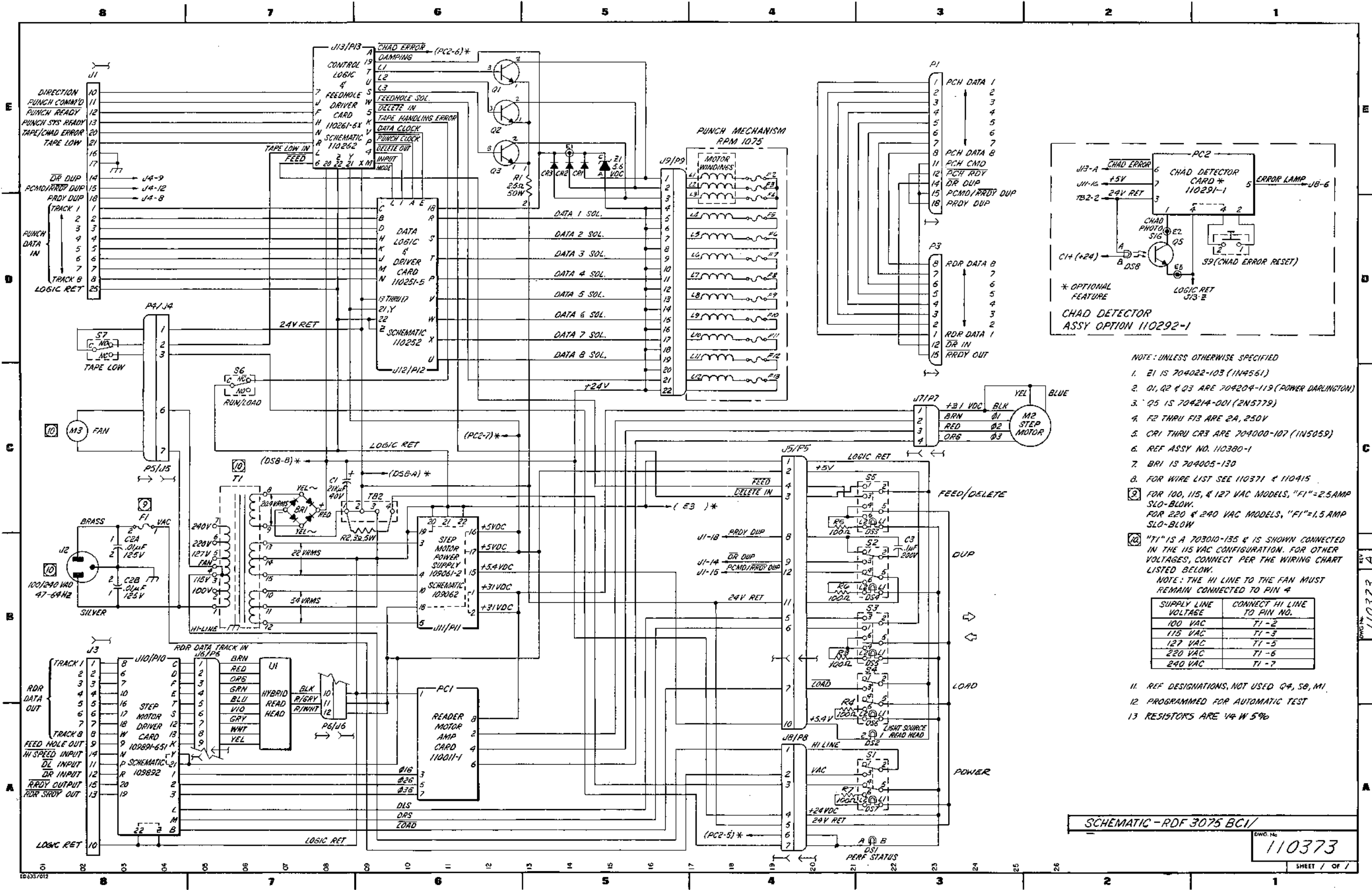

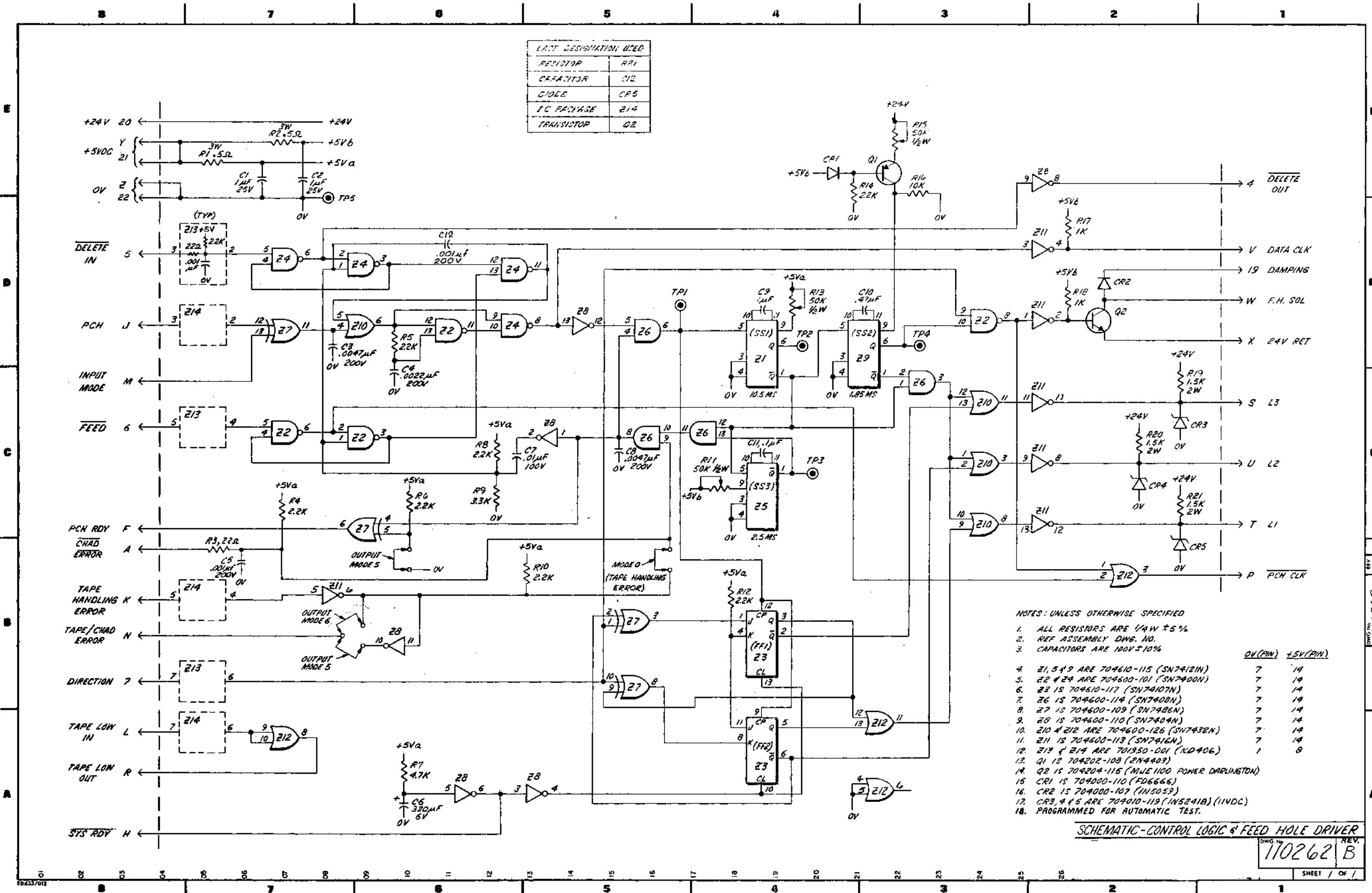

RSM-207V Figure 8-5. Schematic, Control Logic and Feed Hole Driver Card 8-11/8-12 110261

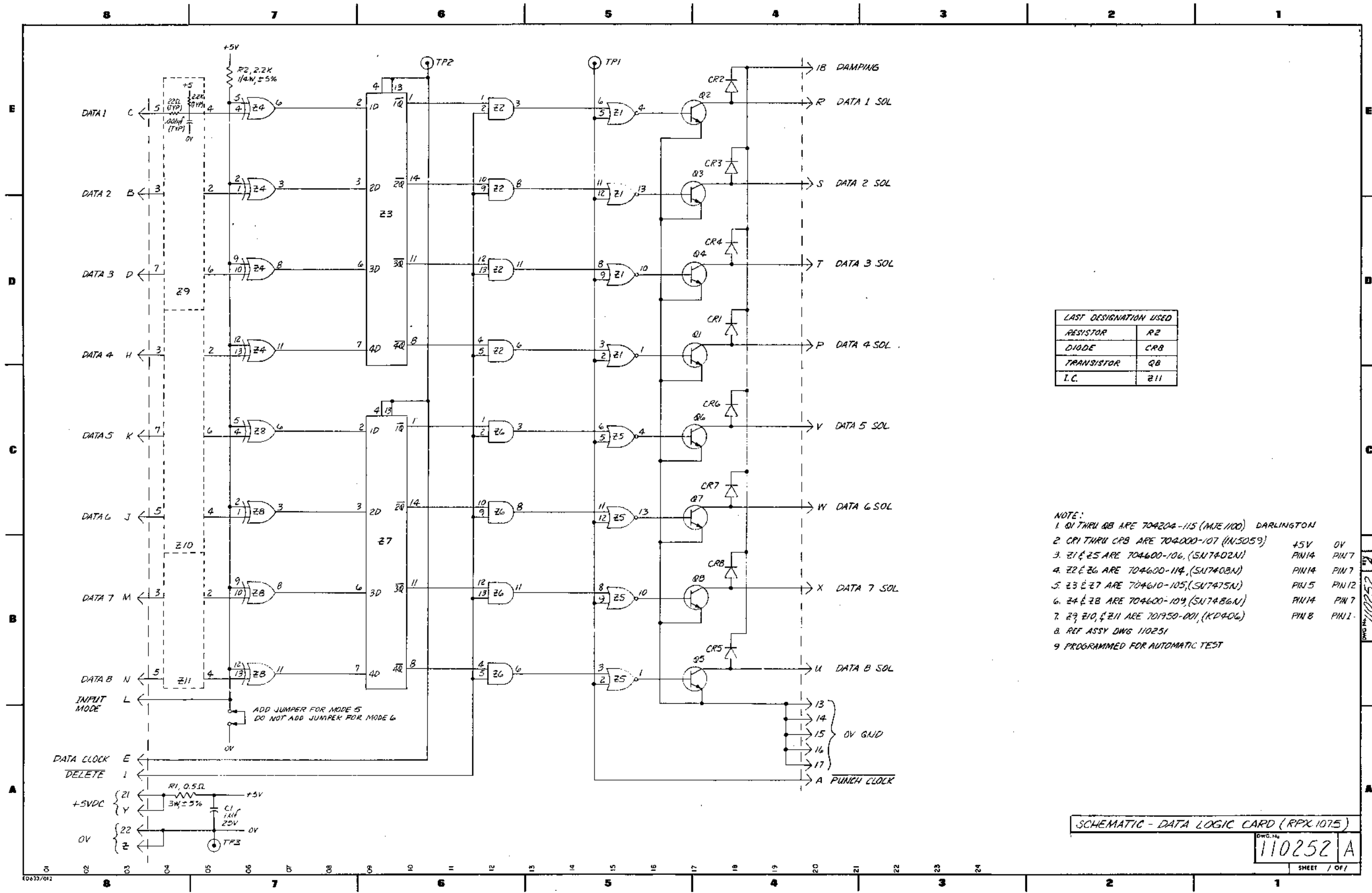

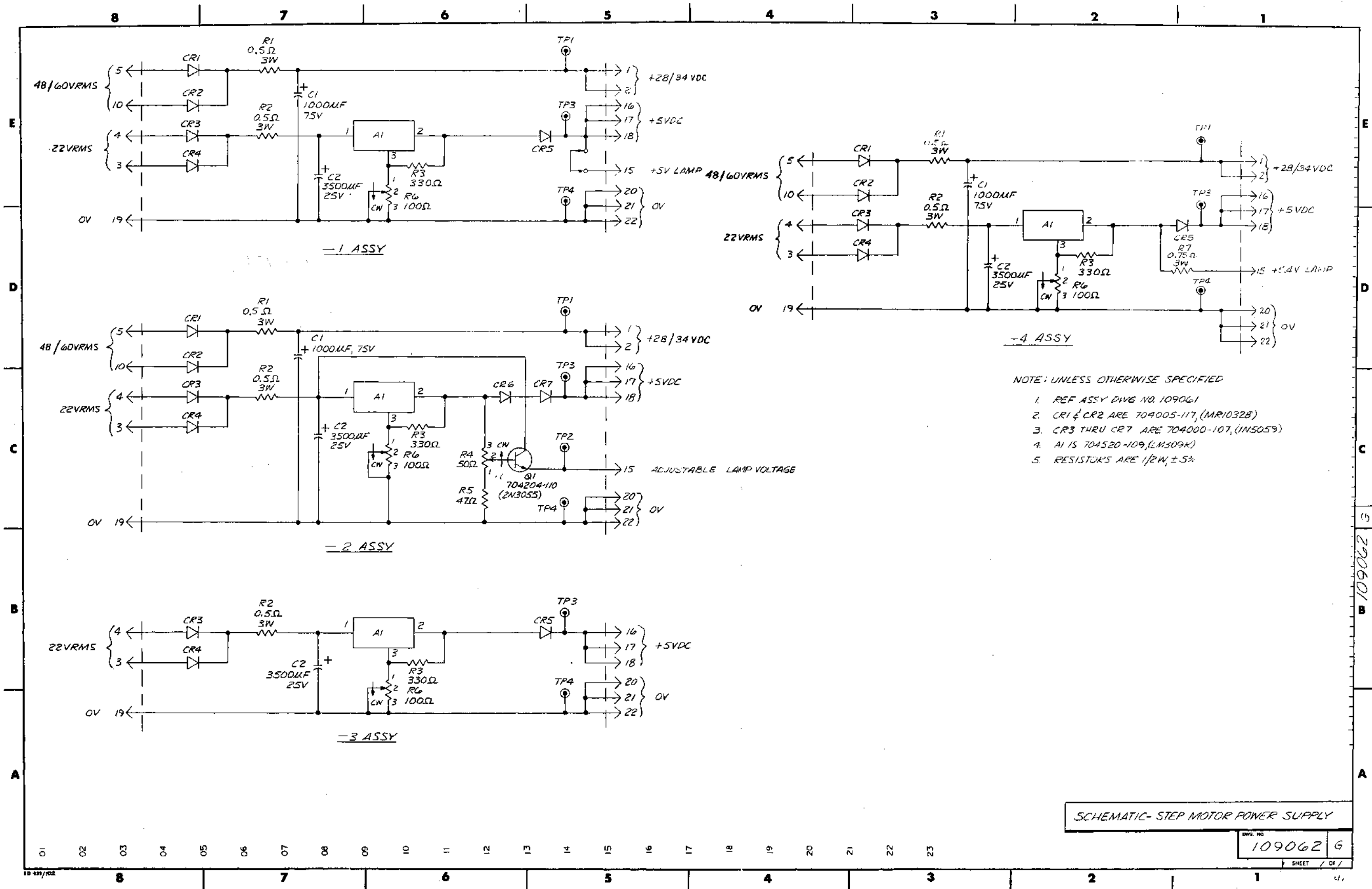

SCHEMATIC-STEP MOTOR POWER SUPPLY

109062 G

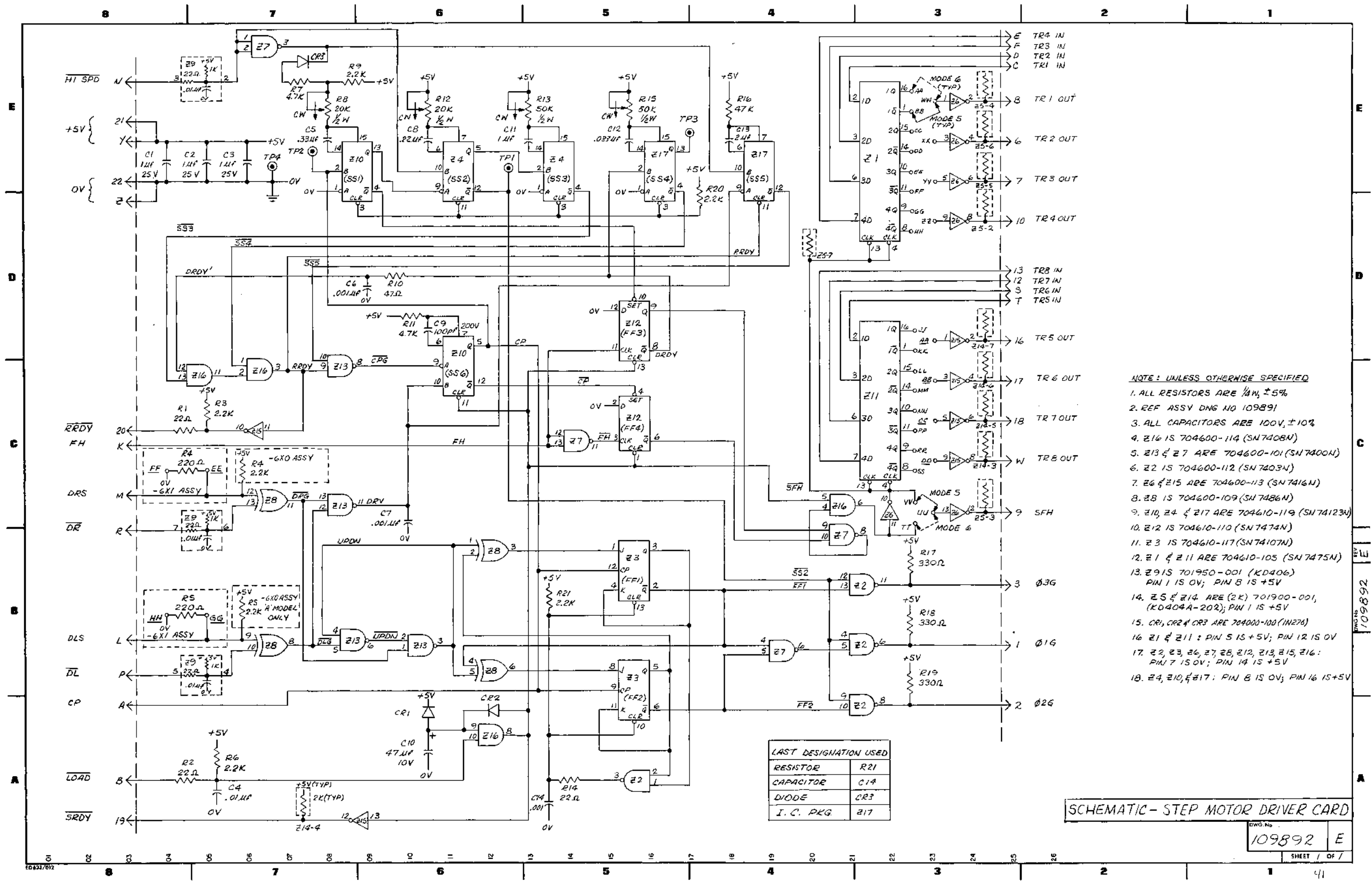

- NOTE: UNLESS OTHERWISE SPECIFIED
1. ALL RESISTORS ARE 1/4W, ±5%
 2. REF ASSY DNG NO 109891
 3. ALL CAPACITORS ARE 100V, ±10%
 4. Z16 IS 704600-114 (SN7408N)
 5. Z13 & Z7 ARE 704600-101 (SN7400N)
 6. Z2 IS 704600-112 (SN7403N)
 7. Z6 & Z15 ARE 704600-113 (SN7416N)
 8. Z8 IS 704600-109 (SN7486N)
 9. Z10, Z4 & Z17 ARE 704610-119 (SN74123N)
 10. Z12 IS 704610-110 (SN7474N)
 11. Z3 IS 704610-117 (SN74107N)
 12. Z1 & Z11 ARE 704610-105 (SN7475N)
 13. Z9 IS 701950-001 (KD406)
PIN 1 IS 0V; PIN 8 IS +5V
 14. Z5 & Z14 ARE (2K) 701900-001,
(KD404A-202); PIN 1 IS +5V
 15. CR1, CR2 & CR3 ARE 704000-100 (IN276)
 16. Z1 & Z11: PIN 5 IS +5V; PIN 12 IS 0V
 17. Z2, Z3, Z6, Z7, Z8, Z12, Z13, Z15, Z16:
PIN 7 IS 0V; PIN 14 IS +5V
 18. Z4, Z10, & Z17: PIN 8 IS 0V; PIN 16 IS +5V

LAST DESIGNATION USED	
RESISTOR	R21
CAPACITOR	C14
DIODE	CR3
I. C. PKG	Z17

SCHMATIC - STEP MOTOR DRIVER CARD
 DWG No 109892 E
 SHEET 1 OF 1

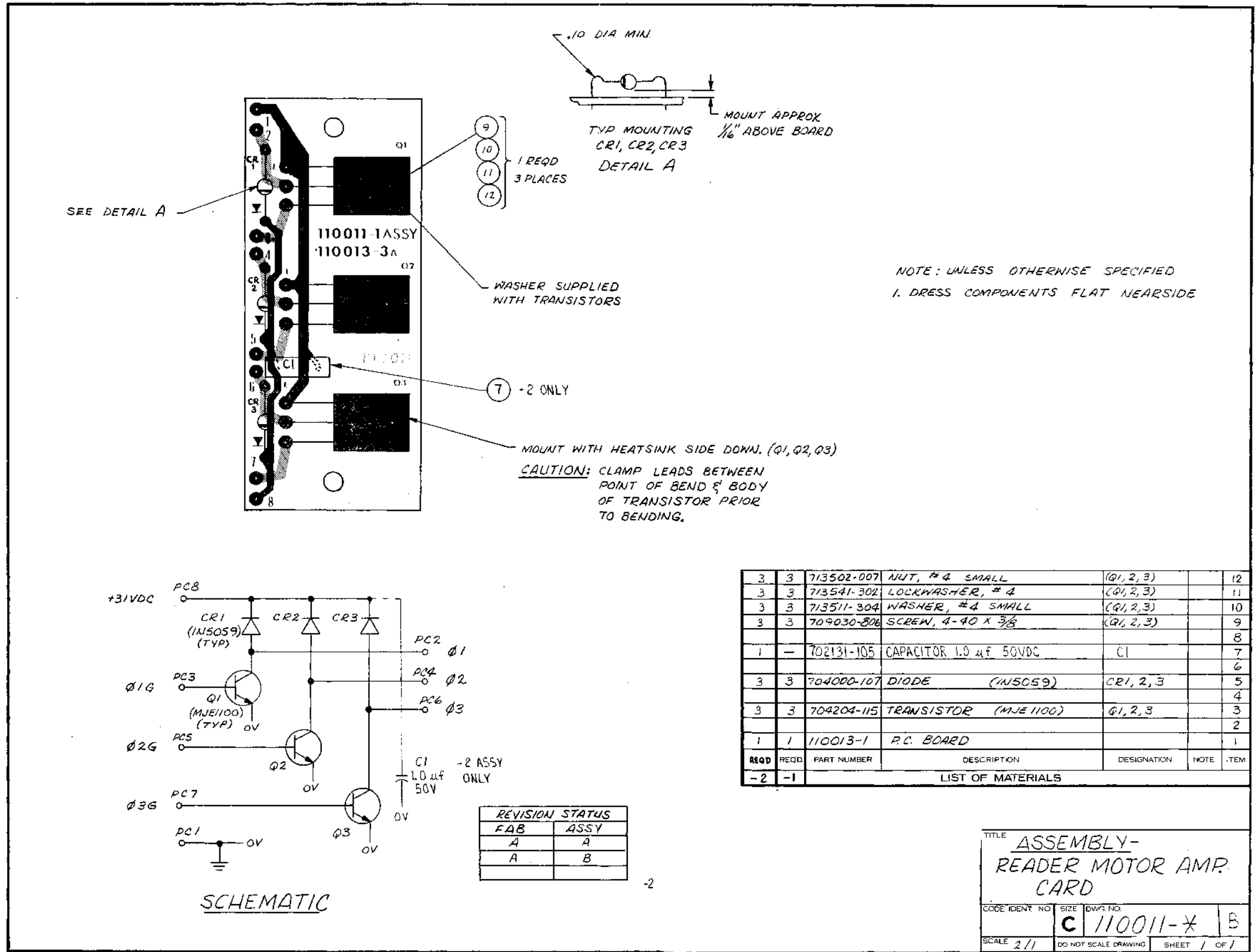

SEE DETAIL A

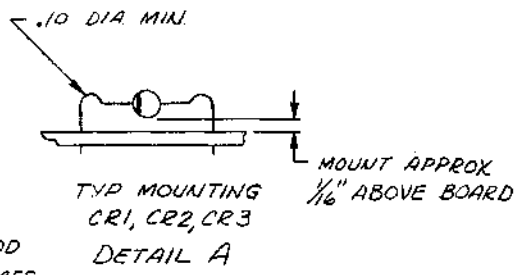

- 9
 - 10
 - 11
 - 12
- 1 REQD
3 PLACES

NOTE: UNLESS OTHERWISE SPECIFIED
1. DRESS COMPONENTS FLAT NEARSIDE

WASHER SUPPLIED WITH TRANSISTORS

7 -2 ONLY

MOUNT WITH HEATSINK SIDE DOWN. (Q1, Q2, Q3)

CAUTION: CLAMP LEADS BETWEEN POINT OF BEND & BODY OF TRANSISTOR PRIOR TO BENDING.

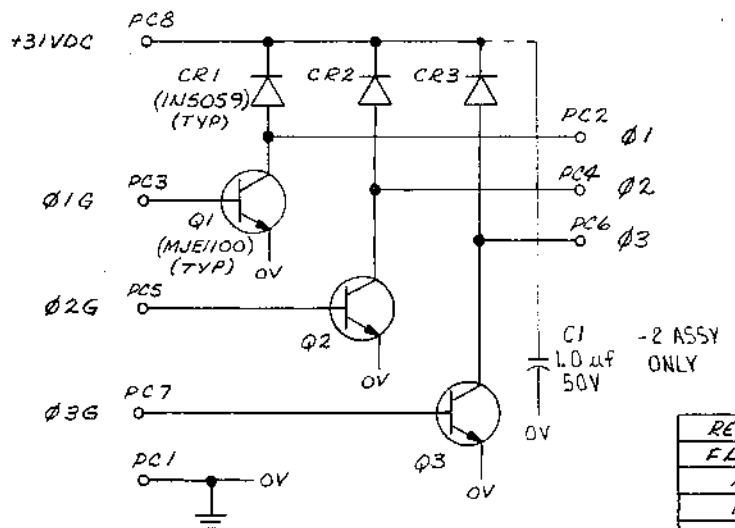

REVISION STATUS	
FAB	ASSY
A	A
A	B

REQD	REQD	PART NUMBER	DESCRIPTION	DESIGNATION	NOTE	ITEM
3	3	713502-007	NUT, #4 SMALL	(Q1, 2, 3)		12
3	3	713541-302	LOCKWASHER, #4	(Q1, 2, 3)		11
3	3	713511-304	WASHER, #4 SMALL	(Q1, 2, 3)		10
3	3	709030-806	SCREW, 4-40 X 3/8	(Q1, 2, 3)		9
1	-	702131-105	CAPACITOR 1.0 uF 50VDC	C1		7
3	3	704000-107	DIODE (IN5059)	CR1, 2, 3		5
3	3	704204-115	TRANSISTOR (MJE1100)	Q1, 2, 3		3
1	1	110013-1	P.C. BOARD			1
-2	-1					

LIST OF MATERIALS

TITLE: ASSEMBLY-
READER MOTOR AMP.
CARD

CODE IDENT NO: C SIZE: 110011-* DWG NO: B

SCALE: 2/1 DO NOT SCALE DRAWING SHEET 1 OF 1

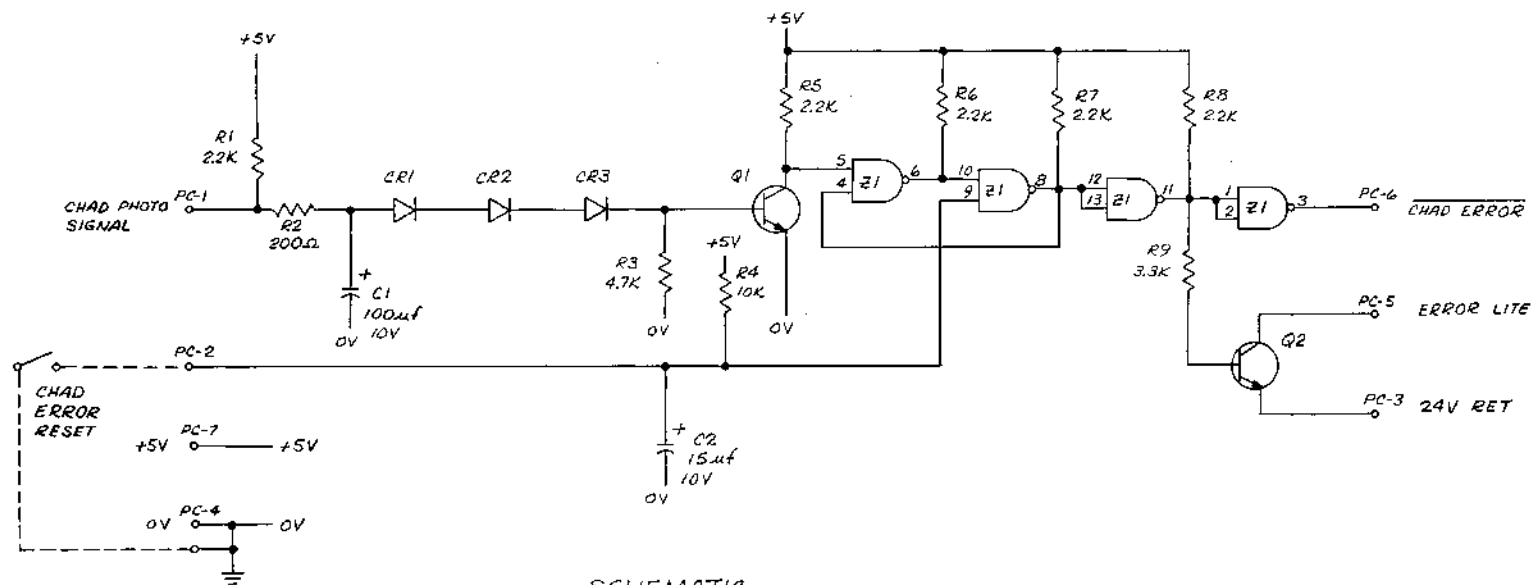
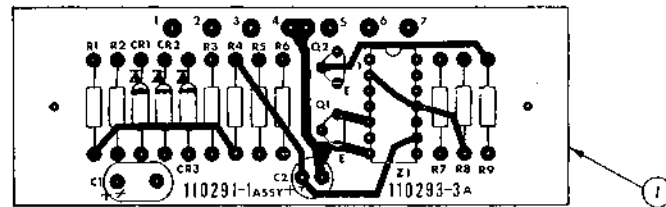

SCHEMATIC

NOTE: UNLESS OTHERWISE SPECIFIED
 1. DRESS COMPONENTS FLAT NEAR SIDE
 2. Z1 PIN 14 IS +5V, PIN 7 IS 0V

					50
					49
					48
					47
					46
					45
					44
					43
					42
					41
					40
					39
					38
					37
					36
					35
					34
					33
					32
					31
					30
					29
					28
					27
					26
					25
					24
					23
					22
					21
					20
					19
					18
1	701003-332	RESISTOR 3.3K 1/4W, ±5%	R9		18
1	701003-103	10K	R4		17
1	701003-472	4.7K	R3		16
1	701003-201	200Ω	R2		15
5	701003-222	RESISTOR 2.2K 1/4W, ±5%	R1,5,6,7,8		14
					13
					12
2	704203-114	TRANSISTOR (2N4401)	Q1,2		11
					10
3	704000-110	DIODE (1FD6666)	CR1,2,3		9
					8
1	702393-156	CAPACITOR 15μf, 10V	C2		7
1	702393-107	CAPACITOR 100μf, 10V	C1		6
					5
					4
1	704600-112	I.C. PKG. (SN7403N)	Z1		3
					2
1	110293-1	P.C. BOARD			1
HLDC	PART NUMBER	DESCRIPTION	DESIGNATION	NOTE	ITEM
LIST OF MATERIALS					

TITLE
 ASSEMBLY / SCHEMATIC
 CHAD DETECTOR CARD

CODE IDENT. NO. SIZE QWG. NO.
 D 110291-1 A

SCALE 2/1 DO NOT SCALE DRAWING SHEET 1 OF 1

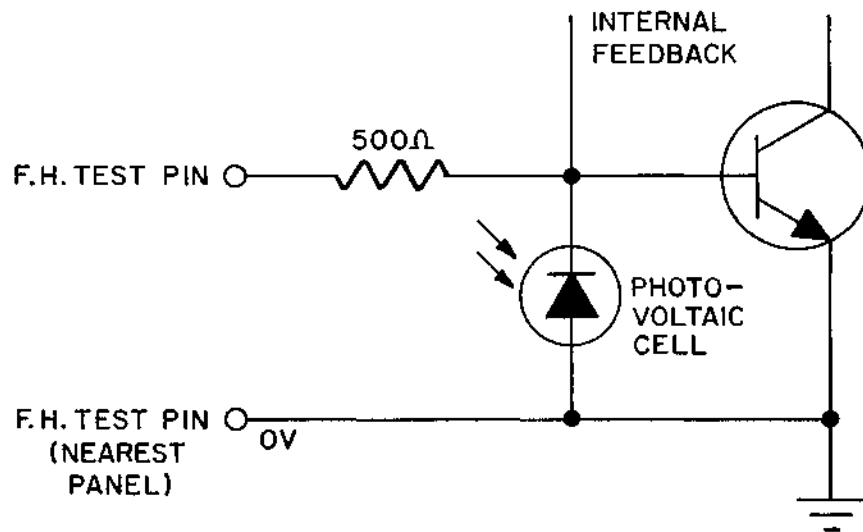

MMC 225

Figure 8-11. Feed Hole Test Pin Circuitry, Reader Sensor

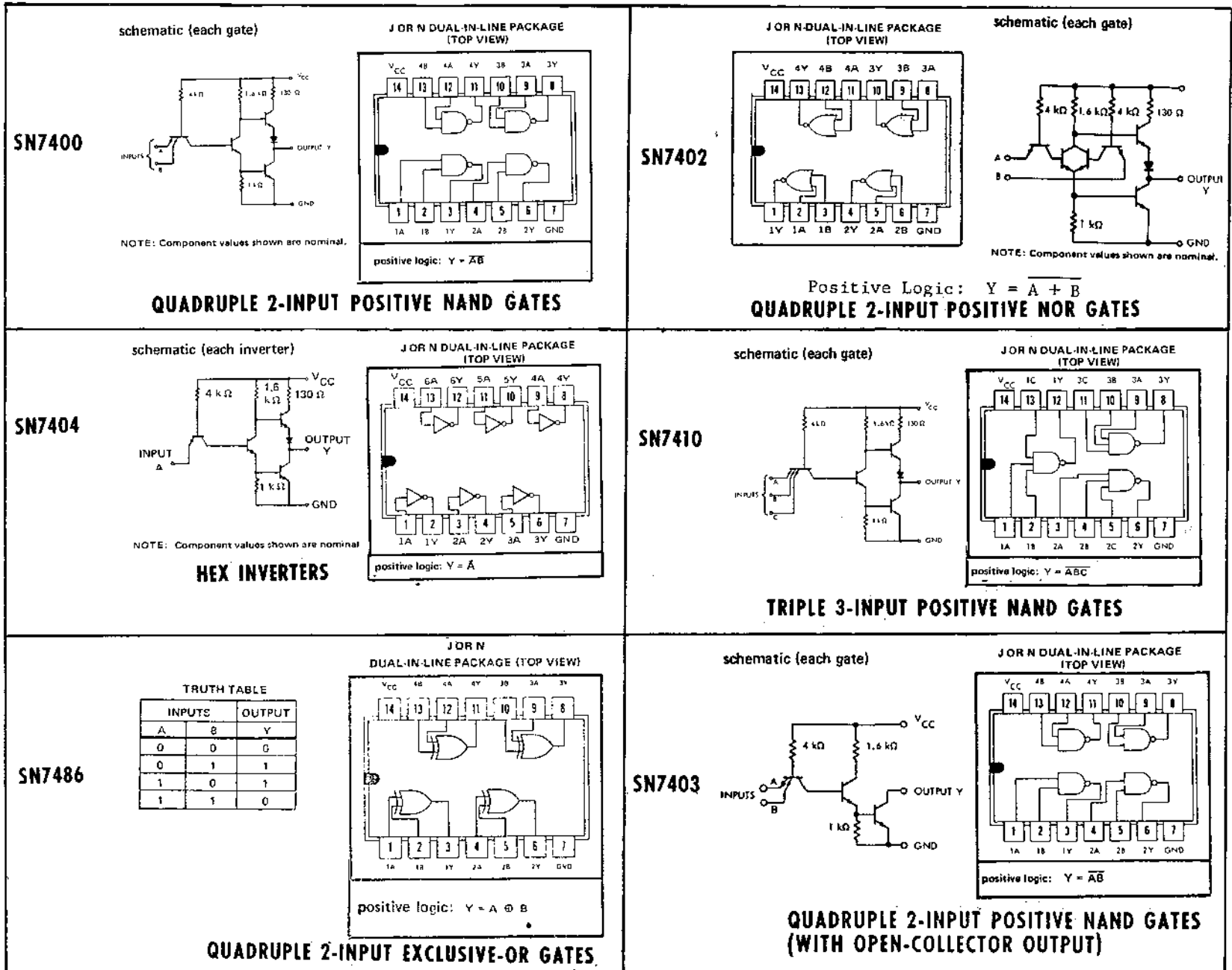

MMC 235

Figure 8-12. IC Assembly Modules Used on the Circuit Cards

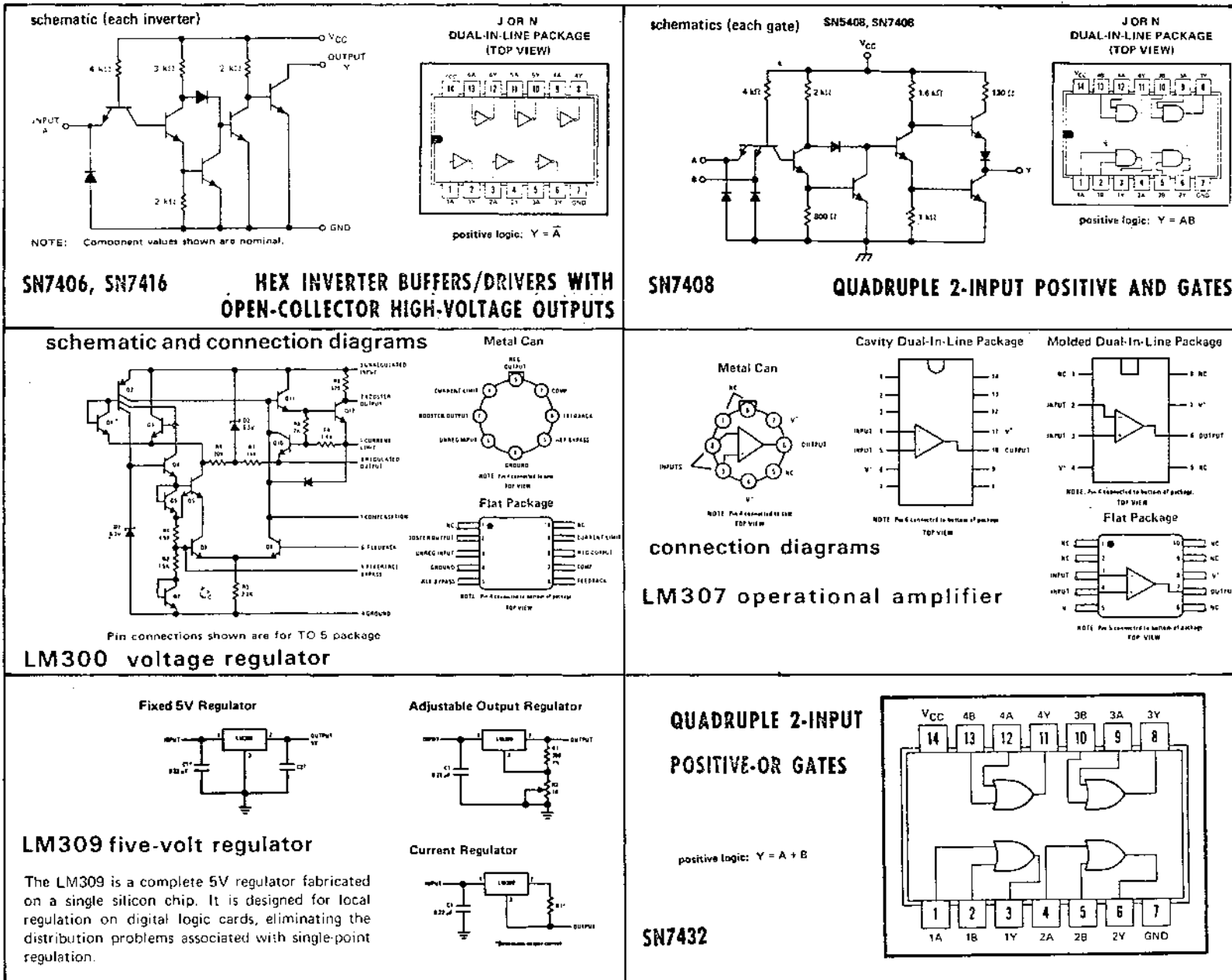

MMC238

Figure 8-13. IC Modules Used on the Circuit Card

SN7473, SN74107

t_n		t_{n+1}	
J	K	Q	\bar{Q}
0	0	Q _n	0
0	1	0	1
1	0	1	0
1	1	\bar{Q}_n	1

NOTES: 1. t_n = Bit time before clock pulse.
2. t_{n+1} = Bit time after clock pulse.

DUAL J-K MASTER-SLAVE FLIP-FLOPS

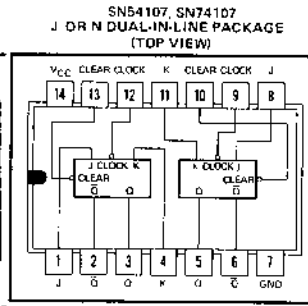
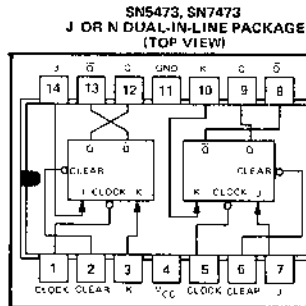

positive logic: Low input to clear sets Q to logical 0.
Clear is independent of clock.

SN7475, SN7477

t_n	t_{n+1}
D	Q
1	1
0	0

NOTES: 1. t_n = bit time before clock pulse transition.
2. t_{n+1} = bit time after clock pulse transition.
NC—No Internal Connection

8-BIT AND 4-BIT BISTABLE LATCHES

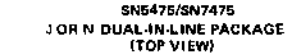
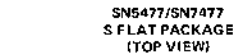

positive logic: see truth table

SN74121

t_n INPUT			t_{n+1} INPUT			OUTPUT
A1	A2	B	A1	A2	B	
1	1	0	1	1	1	Inhibit
0	X	1	0	X	0	Inhibit
X	0	1	X	0	0	Inhibit
0	X	0	0	X	1	One Shot
X	0	0	X	0	1	One Shot
1	1	1	X	0	1	One Shot
1	1	1	0	X	1	One Shot
X	0	0	X	1	0	Inhibit
0	X	0	1	X	0	Inhibit
X	0	1	1	1	1	Inhibit
0	X	1	1	1	1	Inhibit
1	1	0	X	0	0	Inhibit
1	1	0	0	X	0	Inhibit

$$I = V_{in(1)} \geq 2V$$

$$O = V_{in(0)} \leq 0.8V$$

NOTES: 1. t_n = time before input transition.
2. t_{n+1} = time after input transition.
3. X indicates that either a logical 0 or 1, may be present.
4. NC = No Internal Connection.

MONOSTABLE MULTIVIBRATORS

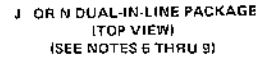

positive logic: see truth table and notes 5 and 6

- A1 and A2 are negative-edge-triggered logic inputs, and will trigger the one shot when neither or both go to logical 0 with B at logical 1.
- B is a positive Schmitt-trigger input for slow edges or level detection, and will trigger the one shot when B goes to logical 1 with either A1 or A2 at logical 0. (See Truth Table)

Figure 8-14. IC Modules Used on the Circuit Card

SN7474

TRUTH TABLE (Each Flip-Flop)

t_n		t_{n+1}	
INPUT	OUTPUT	OUTPUT	OUTPUT
D	Q	Q	\bar{Q}
0	0	0	1
1	1	1	0

NOTES 1. t_n = bit time before clock pulse.
2. t_{n+1} = bit time after clock pulse

DUAL D-TYPE EDGE-TRIGGERED FLIP-FLOPS

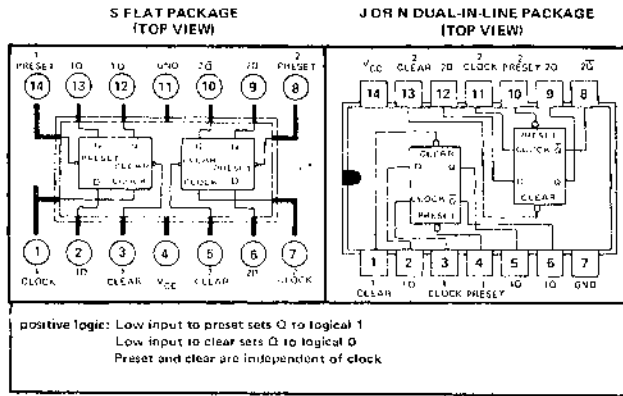

SN74123

RETRIGGERABLE MONOSTABLE MULTIVIBRATORS WITH CLEAR

TRUTH TABLE (See Note A)

INPUTS		OUTPUTS	
A	B	Q	\bar{Q}
H	X	L	H
X	L	L	H
L	L	L	H
L	H	\bar{L}	\bar{H}

NOTES:

- A. H = high level (steady state), L = low level (steady state), L = transition from low to high level, H = transition from high to low level, \bar{L} = one high-level pulse, \bar{H} = one low-level pulse, X = irrelevant (any input, including transitions).
- B. NC = No internal connection.
- C. To use the internal timing resistor of SN54122/SN74122 (10 k Ω nominal), connect R_{int} to V_{CC} .
- D. An external timing capacitor may be connected between C_{ext} and R_{ext}/C_{ext} (positive).

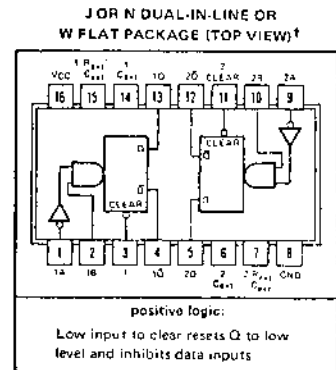

TTL/MONOSTABLE 9602 RETRIGGERABLE RESETTABLE MONOSTABLE MULTIVIBRATOR

GENERAL DESCRIPTION - The TTL/Monostable 9602 is a dual retriggerable, resettable monostable multivibrator which provides an output pulse whose duration and accuracy is a function of external timing components. The 9602 has excellent immunity to noise on the V_{CC} and ground lines. The 9602 uses TTL inputs and outputs for high speed and high fanout capability and is compatible with all members of the Fairchild TTL family.

TRIGGERING TRUTH TABLE

	PIN NO.'S.			Operation
	5(11)	4(12)	3(13)	
H \rightarrow L	L	H		Trigger
H	L \rightarrow H	H		Trigger
X	X	L		Reset

H = HIGH Voltage Level
L = LOW Voltage Level
X = Don't Care
H \rightarrow L = HIGH to LOW Voltage Level transition
L \rightarrow H = LOW to HIGH Voltage Level transition

CONNECTION DIAGRAM DIP (TOP VIEW)

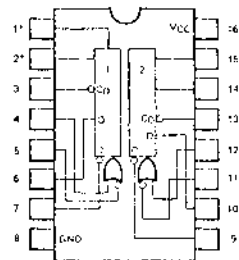

*Pins for external timing.

MMC237

Figure 8-15. IC Modules Used on the Circuit Card

COMPONENT 1 REF DESIGNATOR	SYMBOL	REMARKS	COMPONENT 4 REF DESIGNATOR	SYMBOL	REMARKS
SWITCH, 'S'	S1 S2 (N.C.) (N.O.)		INTEGRATED CIRCUIT PACKAGE	AND, NAND, NOR, AND, OR, EXCLUSIVE OR, INVERTER, AMPLIFIER	* ZXX INDICATES I.C. PKG. LOCATION ON P.C. CARD. (LEFT TO RIGHT TOP TO BOTTOM SEQUENCE) (X=NUMBER, Y=LETTER) * ZFY INDICATES I.C. PKG. LOCATION ON P.C. CARD IN XY COORDINATE SYSTEM. (X=NUMBER, Y=LETTER) NOTE: EITHER NUMBERING SYSTEM SHOWN ABOVE MAY BE USED DEPENDING ON SIZE OR COMPLEXITY OF P.C. CARD
SAFETY INTERLOCK	S1 S2 N.O. N.C.				
LIMIT SW.	S1 S2 N.O. N.C.				
POWER	S1 PWR ON				
PUSH BUTTON, 'PB'	PB1 PB2 N.O. N.C.				
TRANSFER	S7 S5 N.C. N.O. OFF		POSITIVE TRUE LOGIC SYMBOLS		
TIMER CONTACTS	SPDT 3 POSITION CENTER OFF DELAY OCCURS WHEN COIL IS EMERGED DE-ENERGIZED				
TRANSISTOR, 'Q'	Q1 Q2 PNP NPN				
VJT, 'D'	D1 D2 'N' TYPE 'P' TYPE	ARROW POINTS TOWARD D1 FOR 'N' TYPE & AWAY FROM D1 FOR 'P' TYPE			
FET, 'Q'	Q1 Q2 'N' TYPE 'P' TYPE				
DIODE 'CR' or 'D'		* USE 'D' ON N/C APPLICATIONS			
ZENER DIODE 'CR'	XXV	V-VOLTS			
SOLENOID 'SOL'					
TRIAC		INDICATE TERMINALS 1 AND 2			
SCR					
BRIDGE RECTIFIER 'BR' 'O'		* USE 'D' ON N/C APPLICATIONS			
CABLE RUN (OPTIONAL)	X1 X6 X2 X3 X4 X5 X6				
CABLE, 2 OR MORE CONDUCTORS		IF SHIELDED CONDUCTOR SHOW TERMINATION OF SHIELD			
TWISTED WIRES	PAIR TRIPPLE				
COAXIAL CABLE					

NOTE:
ALL SEMICONDUCTORS AND INTEGRATED CIRCUIT DEVICES
ARE TO BE IDENTIFIED BY REMEX PART NUMBER ADJACENT
TO DEVICE OR IN GENERAL NOTES. COMMERCIAL PART
NUMBERS MAY ALSO BE SHOWN AT OPTION OF PROJECT
ENGINEER.

STANDARD SCHEMATIC SYMBOLS
107700 8
107700 8

Figure 8-16. REMEX Standard Schematic Symbols, Sheet 1.

COMPONENT # REF DESIGNATOR	SYMBOL	REMARKS	COMPONENT # REF DESIGNATOR	SYMBOL	REMARKS
CAPACITOR 'C'		GIVE CAPACITANCE & VOLTAGE OR COVER IN NOTES	TERMINAL 'E'		USE 'E', LOGICAL DESCRIPTION OR BOTH
CELL, PHOTOSENSITIVE 'V'					
GND					
COIL, RELAY 'K' OR NUMERICAL DESIGNATOR CONTACTS					
CONTACT, CONNECTOR 'P', 'J'					
SEPARABLE CONNECTORS, ENGAGED		DEFINITION: PLUG: USUALLY MOVABLE JACK: USUALLY STATIONARY HERMAPHRODITE: PLUG: JACK:			
CONNECTORS, AC POWER 'P', 'J'					
FUSE, 'F'					
INDUCTOR, WINDING, 'L', REACTOR		GIVE INDUCTANCE OR COVER IN NOTES			
TRANSFORMER 'T'		POLARITY DOTS TO BE SHOWN IF NECESSARY TO CIRCUIT FUNCTION			
LAMP, INDICATING 'DS'					
CRYSTAL, 'Y'					
BOARD- TERMINAL 'TB' OR FANNING STRIP 'FS'					
EYELET, PC CARD					
TEST POINT, 'TP'					
JUMPER, WIRE, PC		FOR OPTIONAL WIRING			
RESISTOR, FIXED, VARIABLE 'R'		OPTIONAL ADJUSTMENT SYMBOL: SCREEN DRIVER POWER WAITING AND TOLERANCE TO BE SHOWN OR PUT IN NOTES			
LAMP, GLOW 'N'					
LINE CROSS					
LINE CONNECT					

STANDARD SCHEMATIC SYMBOLS
107700 B
SHEET 2 OF 2

Figure 8-16. REMEX Standard Schematic Symbols, Sheet 1.

ADDENDUM SHEET

The following changes in the manual are required:

1. On page 7-7, as part of front panel assemblies 110416-1 and 110419-1 add the following items:

<u>Description</u>	<u>REMEX Part No.</u>	<u>Quantity</u>	<u>Reference Designation</u>
Capacitor, .1uf, 25VDC, Monolithic, Sprague 3C023104D8250A3	702129-104	1	C4
Capacitor, .01uf, 1400VDC, Dual Ceramic, Sprague 36C219	702127-103	1	C5
Filter, Ferroxcube VK200-10/3B	702500-107	2	L13,L14
Resistor, 10 ohm, 1/4W	701003-100	1	R10
Terminal Strip, 4 Terminals, Cinch Jones 54B	715010-121	2	TB3,TB4

2. On page 5-20, steps b through i of Section 5.5.2 should read as follows. Also add step j.
 - b. Place an oscilloscope probe at TP2 and the ground lead at TP5.
 - c. Place the FEED/DELETE switch in the DELETE position. The remaining steps are to be performed with a nominal line voltage of 115 VAC (or that voltage on which the transformer is set to run; not the 10% high or low tolerance).
 - d. Observe the positive pulse at TP2 and adjust R13 for pulse width of 10.5 ± 0.2 msec. See Figure 4-3.
 - e. Place the scope probe at TP4 and adjust R15 for a positive pulse width of 1.85 msec. See Figure 4-3.
 - f. Place the scope probe at TP3 and adjust R11 for a negative pulse width of 2.5 ± 0.1 ms. See Figure 4-3.
 - g. Continue punching approximately 50 feet with all holes after steps d through f have been performed.
 - h. Examine the tape holes for poor punching (double punch, torn holes, incomplete punch, etc.) and perform step i or j as required.
 - i. If the holes are elongated, torn, or double punched, adjust R15 to decrease the pulse width at TP4. Do not go below 1.5 ms.
 - j. If the holes are not being punched or are not being punched completely, adjust R15 to increase the pulse width at TP2. Do not go above 2.0 ms.