

INTERFACING GUIDE
FOR
iCOM MODEL FD3700 SERIES FLOPPY DISK SYSTEMS
iCOM FRUGAL FLOPPY[™] MODEL FF37
AND
CONTROLLER/FORMATTER MODEL CF3700



DOCUMENT NUMBER
250468B

JULY 1978

NOTICE

Information contained within this document may not be reproduced, distributed or disclosed in full or in part by any person without prior approval of Pertec Computer Corporation, Microsystems Division.

Marketing Headquarters

Pertec Computer Corporation
Microsystems Division
20630 Nordhoff Street
Chatsworth, CA 91311
Phone (213) 998-1800
TWX (910) 494-2788

International Marketing Headquarters

Pertec Computer Corporation
Business Systems Division
17112 Armstrong Avenue
Irvine, CA 92714, USA
Phone (714) 540-8340
TWX (910) 595-1912

TABLE OF CONTENTS

Section	Page
I <u>General Description</u>	1
1-1 Introduction1
1-2 Features1
1-3 Physical Description1
1-4 Power Requirements2
1-5 3700 Controller/Formatter2
1-6 Disk Drive2
II <u>Operational Description</u>	.3
2-1 Input Commands3
2-2 Input Command3
2-3 Output Data4
2-4 Operational Sequence4
2-5 Seek5
2-6 Seek Track \emptyset4
2-7 Read4
2-8 Write5
2-9 Write With Deleted Address Mark5
2-10 Clear Error Flags5
2-11 Clear5
2-12 Operational Timing6
2-13 Functional Characteristics7
2-14 Seek7
2-15 Seek Track \emptyset7
2-16 Read7
2-17 Write8
2-18 Read CRC8

TABLE OF CONTENTS (cont)

Section	Page
2-19 Status8
3-20 Busy9
3-21 UN0 and UN1 Unit Select Code9
3-22 Media or CRC Error.9
3-23 Selected Unit Write Protect.9
3-24 Drive Fail10
3-25 Found Deleted Address Mark10
III <u>Interfacing Requirements</u>11
3-1 Signal Levels11
3-2 CF3700 Input Signals11
3-3 CF3700 Output Signals.12
3-4 Cable Installation.12
3-5 I/O Cable.12
3-6 P9 Connector.12
3-7 P5 Connector.13
3-8 P4 Connector.14
2-9 Disk Drive Cable15
2-10 Z1 and Z2 Interconnecting Cables15
2-11 P8 Connector.16
3-12 Interconnection Diagram17
3-13 Signal Flow Diagram18
IV <u>Interfacing Diagrams</u>19

LIST OF ILLUSTRATIONS

Figure	Page
1-1 Top View, FD3712 Dual Drive	vi
1-2 FF37-1, Single Drive Frugal Floppy tm	vi
1-3 CF3700 Controller/Formatter, With Optional Cables	2
2-1 Commands and Input Data Timing	6
2-2 Output Data and Status Timing	6
3-1 Input Receivers	11
3-2 Output Drivers	12
3-3 Interconnection Diagram	17
3-4 Signal Flow Diagram	18
4-1 8080 Interfacing Diagram	20
4-2 8080 Alternate Interfacing Diagram	20
4-3 6800 Interfacing Diagram	21
4-5 RCA 1800 Interfacing Diagram	22

LIST OF TABLES

Table	Page
2-1 Input Commands	3
2-2 Input Data	3
2-3 Seek Specifications	6
2-4 Read/Write Specifications	6
3-1 P5 Connector	13
3-2 P4 Connector	14
3-3 Disk Drive Cable	15
3-4 P8 Connector	16

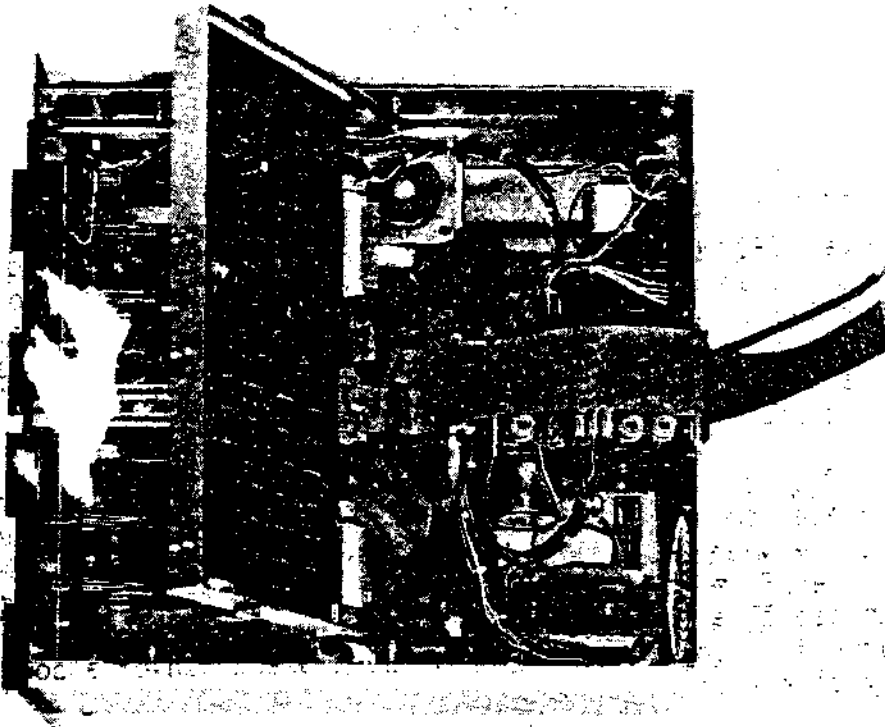

Figure 1-1. Top View, FD3712 Dual Drive
(cover removed and card cage elevated)

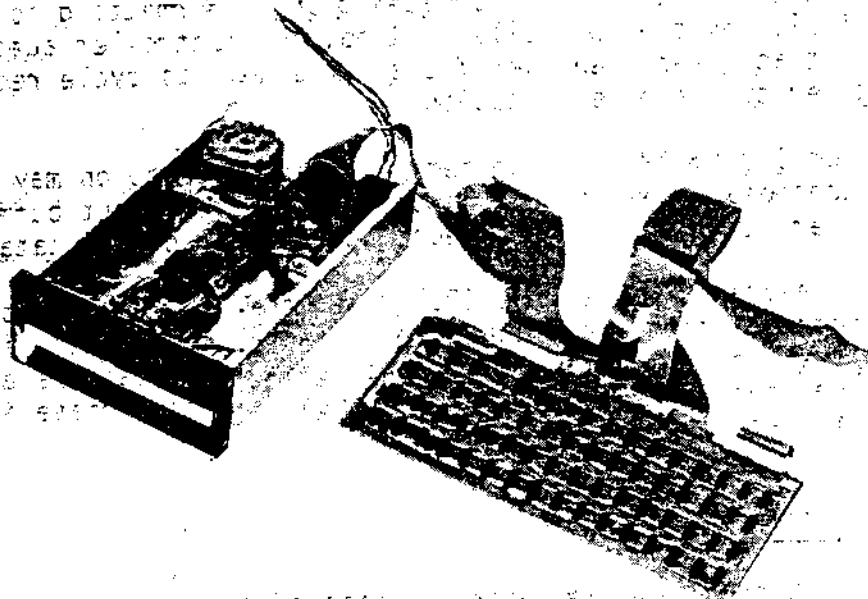

Figure 1-2: FF37-1, Single Drive Frugal Floppytm

SECTION I

GENERAL DESCRIPTION

1-1 INTRODUCTION

The Model CF3700 Floppy Disk Controller/Formatter is used in the ICOM FD3700 and FF37 series floppy disk systems (see also figures 1-1 and 1-2). These floppy disk systems employ Model 511 AC driven disk drives. The controller is designed for easy integration into commercial, industrial, and development applications.

The CF3700 is capable of driving up to four floppy disk drives. Within the controller is a general purpose interface which is compatible with most minicomputers and microcomputers. The Controller/Formatter consists of two printed circuit boards, designated Z1 and Z2. Together, they provide the necessary features for successful and convenient operation of a powerful floppy disk system.

1-2 FEATURES

The CF3700 offers many features which reduce computer service overhead. For example, the controller is compatible with IBM 3540 and 3740 data formats. All formatting and deformatting is done automatically by the controller. Also, the controller automatically performs track, seek, and verification as well as cycle redundancy check generation and verification.

Programmed I/O or DMA (direct memory access) operation may be easily accommodated by the independent input and output buffers. Each buffer can hold one full sector consisting of 128 data bytes.

Interface signals between the CF3700 and the CPU/MPU are comprised of independent input and output data lines as well as an eight bit parallel control port. Controller status indications are routed onto the CPU input data lines when the appropriate input command is received from the CPU.

1-3 PHYSICAL DESCRIPTION

The CF3700 Controller/Formatter consists of two printed circuit boards, Z1 and Z2, that contain a total of 127 integrated circuits. The boards each measure 184 X 381 mm (7.25 X 15 in). All connectors are along one edge of the boards, making the need for card cages or back plane wiring unnecessary. The controller and its optional cables are detailed in figure 1-3.

2-3 OUTPUT DATA

The CF3700 output data to the CPU are DI0 thru DI7, present on connector P4 of Z2. When command bit six (CPU6*) is a one, these data lines contain status information.

2-4 OPERATIONAL SEQUENCE

The following command sequence may be used as guide in developing disk system application software. Numbers within parenthesis are in hex notation.

2-5 SEEK

To perform a Seek operation:

1. Set up CD00 thru CD07 with Unit and Sector.
2. Execute Load Unit/Sector (21). If track is different, set Track Address on DC00 thru CD07.
3. Execute Load Track Address (11).
4. Execute Seek (09).
5. Loop-on-busy by:

Executing Examine Status

Input data, check Busy (0 when completed) and CRC bits.

2-6 SEEK TRACK 0

To perform Seek Track 0 operation:

Use in power-up.

Track address not necessary.

1. Execute Seek Track 0 (00).
2. Loop-on busy as in Seek operation.

2-7 READ

To perform a Read operation:

1. Seek to correct unit, track, and sector.
2. Execute Read (03).
3. Check CRC. Re-read, if DI number is a one.
4. Execute Examine Read Buffer (40).
5. Enter input character.
6. Shift Read Buffer (41).

NOTE

Continue the entering of characters and the incrementing of the Shift Read Buffer, until 128 characters have been entered.

The Status Line signals are:

Busy

UN0, Unit Select Code Bit 0

UN1, Unit Select Code Bit 1

Media or CRC Error

Selected Unit Write Protect

Drive Fail

Found Deleted Data Address Mark

3-20 BUSY

A one indicates that an operation is in process, zero, no operation in process. Busy is cleared by Clear, Clear Error Flags, or head unloading.

3-21 UN0 AND UN1 UNIT SELECT CODE

The code for selecting the desired disk drive unit is:

UN1	UN0	Unit Selected
0	1	0
0	1	1
1	0	2
1	1	3

3-22 MEDIA OR CRC ERROR

These signals indicate a data error in Seek or Read (CRC) operation. Clear Error Flags, clears line before beginning a Read or Write operation.

3-23 SELECTED UNIT WRITE PROTECT

The disk is write protected when this line is low (logical one).

3-24 DRIVE FAIL

Activates to a logical one when drive is not ready or when drive is not fully operable. This may be due to drive not being up to speed, its door is open, diskette not installed, or drive is not properly connected.

3-25 FOUND DELETED ADDRESS MARK

This bit goes low if DDAM precedes a Read command. It is reset by the Clear Error Flags command.

SECTION III

INTERFACING REQUIREMENTS

3-1 SIGNAL LEVELS

All signals pertaining to the Controller/Formatter are standard TTL-compatible negative true. Positive true is available as an option for an additional cost.

3-2 CF3700 INPUT SIGNALS

Logic "0": +2.0V min to +5V max
Logic "1": +0.0V min to +0.8V max

Standard load is a TTL gate (7404 plus 680 ohms to +5V). The other two input load variations shown, are extra cost options designed to accommodate special system requirements.

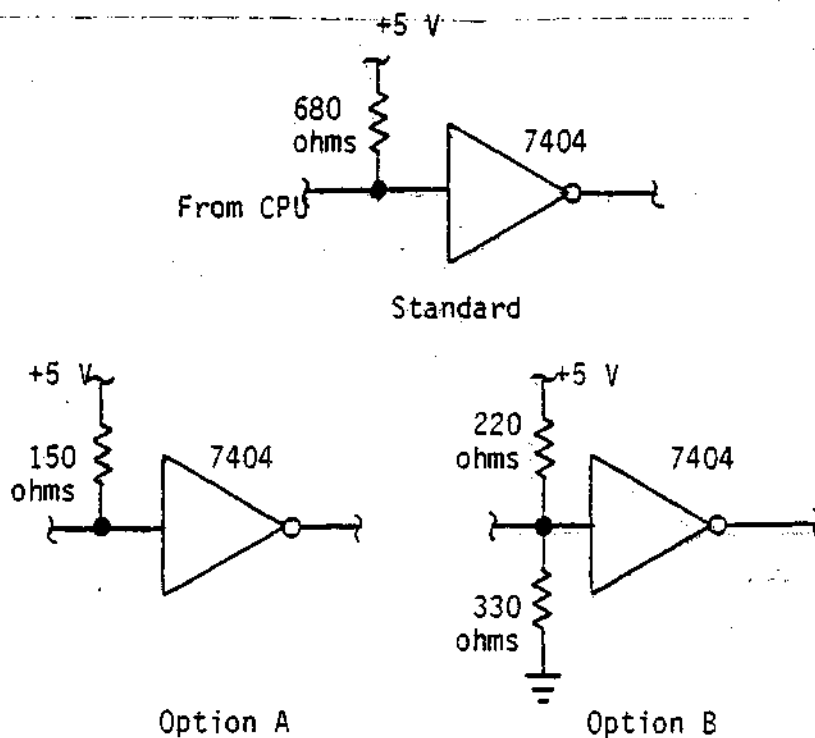

Figure 3-1. Input Receivers

3-3 CF3700 OUTPUT SIGNALS

Logic "0": +2.4V min

Logic "1": +0.0V min to +0.4V max

Current sink at logic "1" is 32 ma

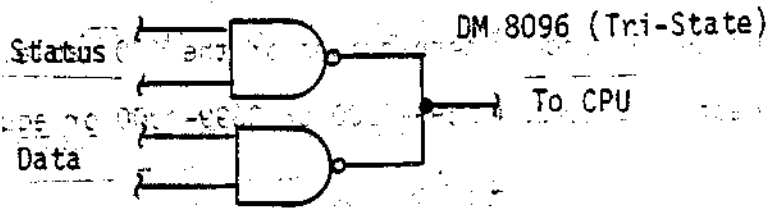

Figure 3-2. Output Drivers

3-4 CABLE INSTALLATION

Four 3M flat cables interconnect the floppy disk system:

<u>P/N</u>	<u>Description</u>
360-27	I/O Cable, connects Controller/Formatter to computer interface.
370-22 (Dual Drive) 370-24 (Four Drive)	Disk Drive Cable, connects drives in a daisy chain fashion to Controller/Formatter.
360-26 and 360-25	Z1 and Z2 Interconnection Cables.

3-5 I/O CABLE

The I/O Cable, a 50 conductor ribbon cable, has a 50 pin connector at one end (P9) and a 20 pin connector (P4) plus a 26 pin connector (P5) at the other end.

3-6 P9 Connector

The 50 pin connector is designated P9 and connects to the interface or CPU of the computer.

The Cable connector is 3M P/N 3433-2002 (solder tail) or 3M P/N 3233-4005 (wire wrap) or equivalent.

The key for this connector is pin 29.

3-7 P5 Connector

P5, the 26 pin connector, mates with P5 of the Z1 board. The output signals from the CPU are routed to P5, the Controller/Formatter input signal connector.

Table 3-1 shows the P9 and P5 connections of the I/O cable.

The cable connector is 3M P/N 3399-0000 or 3399-1000 or equivalent.

NOTE

Reference index of P5 board connector begins at pin 15.

Table 3-1. I/O Cable, P5 Connector

P5 Cable End	P5 on Z1 Board	P9 (CPU end)	Signal	Definition
1-5	15-19		Not used	
2 Key				
5 Key				
		29 Key		
6	20	30	CPU0*	Command Strobe
7	21	31	CPU1*	Command Word
8	22	32	CPU2*	Command Word
9	23	33	CPU3*	Command Word
10	24	34	CPU4*	Command Word
11	25	35	CPU5*	Command Word
12	26	36	CPU6*	Command Word
13	27	37	CPU7*	Command Word
15	29	39	CPU0*	Data out bit 0
16	30	40	CDU1*	Data out bit 1
17	31	41	CDU2*	Data out bit 2
18	32	42	CDU3*	Data out bit 3
19	33	43	CDU4*	Data out bit 4
20	34	44	CDU5*	Data out bit 5
21	35	45	CDU6*	Data out bit 6
22	36	46	CDU7*	Data out bit 7
23-26	37-40	47-50	Signal Ground	

3-8 P4 Connector

The Connector P4, which has 20 pins, mates with P4 of Z2. The CPU input signals are routed through P4, the Controller/Formatter output signal connector.

The P4 and P9 connectors of the I/O cable are detailed in table 3-2.

The cable connector to P4 of Z2 is 3M P/N 3421-0000 or equivalent.

Table 3-2. P4 Connector

P4	P9 (CPU)	Signal	Definition
1-7	1-7	Not Used	
6 Key			
8	8	F DONE*	Done
9	9	DI0/Busy	Data Input 0
10	10	DI1/UN0 Unit Select	Data Input 1
11	11	DI2/UN1	Data Input 2
12	12	DI3/CRC Error	Data Input 3
13	13	DI4/Write Protected	Data Input 4
14	14	DI5/Drive Fail	Data Input 5
15	15	DI6	Data Input 6
16	16	DI7/Deleted Data Address Mark	Data Input 7
17 Key			
18-20	18-20	GRD	

3-9 DISK DRIVE CABLE

The Disk Drive Cable connects the CF3700 to the floppy disk drive. The Controller/Formatter connector is designated P1, and connects to its respective connector on Z2.

Table 3-3: Disk Drive Cable

Pin	Signal	Definition	I/O
1	SEL0*	Drive Select 0	0
2	SEL1*	Drive Select 1	0
3	SEL2*	Drive Select 2	0
5	SEL3*	Drive Select 3	0
6	PHL0D*	Head Load	0
11	WRENA*	Write Enable	0
15	IHIGH*	High Head Current	0
17	IWDATA	Write Data	0
19	ISTIN	Step In	0
21	ISTOUT	Step Out	0
31	DRFAL	Drive Failure	I
32	TRO*	Track Zero	I
33	WP	Write Protect	I
45	INDEX	Index	I
46	RDO*	Read Data	I

Pin 43 is keyed.

3-10 Z1 AND Z2 INTERCONNECTING CABLES

These cables connect the two printed circuit boards, Z1 and Z2, of the Controller/Formatter, CF3700. The P2 cable has 40 conductors, while the P3 cable has 50 conductors.

These interconnecting cables provide for signal transfer between the two sections of the Controller/Formatter.

3-11 P8 CONNECTOR

The printed circuit board edge connector, P8, provides for DC power inputs as well as routing the write protect and the status features to the Z2 board. Table 3-4 furnishes the pin and assigned signal information for P8.

Table 3-4. P8 Connector

<u>Pin</u>	<u>Signal</u>	<u>Description</u>	<u>I/O</u>
1	WP3*	Drive 3 Write Protect	I
A	WP2*	Drive 2 Write Protect	I
2	WP1*	Drive 1 Write Protect	I
B	WP0*	Drive 0 Write Protect	I
3	LDRFAL	Ready	0
C	LBUSY	Busy	0
4	LCRC	CRC Error	0
D	LWRPR	Write Protect	0
5	LUN1	Unit Select Bit 1	0
E	LUN0	Unit Select Bit 0	0
6	+5V		
F	-12V return		
7	+5V		
H	+5V return		
8	+5V		
J	-12V return		
9	+5V		
K	-12V return		
10	-12V		
L	-12 return		

3-12 INTERCONNECTION DIAGRAM

A typical floppy disk system interconnection diagram is given by figure 3-3. Take special note of the fact that drive 0 is at the terminus of the disk drive cable.

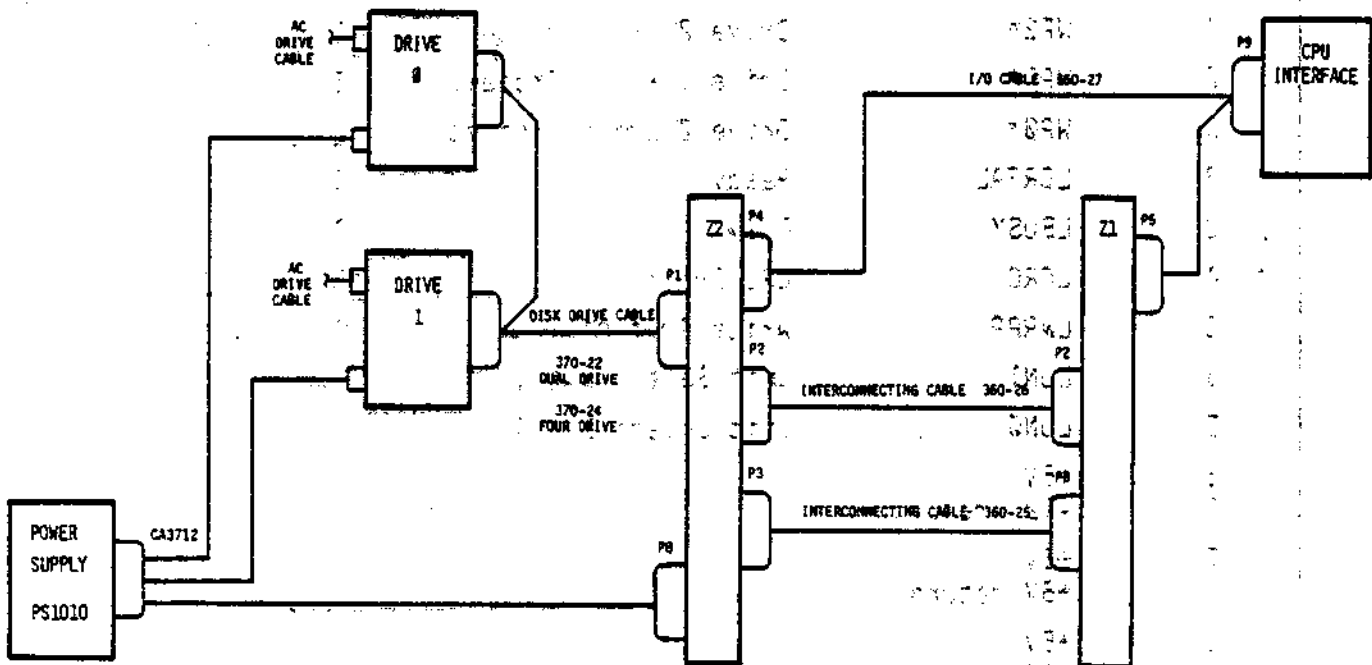

Figure 3-3. Interconnection Diagram

3-13 SIGNAL FLOW DIAGRAM

Figure 3-4 presents the signal flow of a disk drive system, and the CF3700 in particular. Signal flow is from left to right. Thus, an item may appear more than once to illustrate input and output signals. The outputs of Z2 are referenced back to Z1 as inputs.

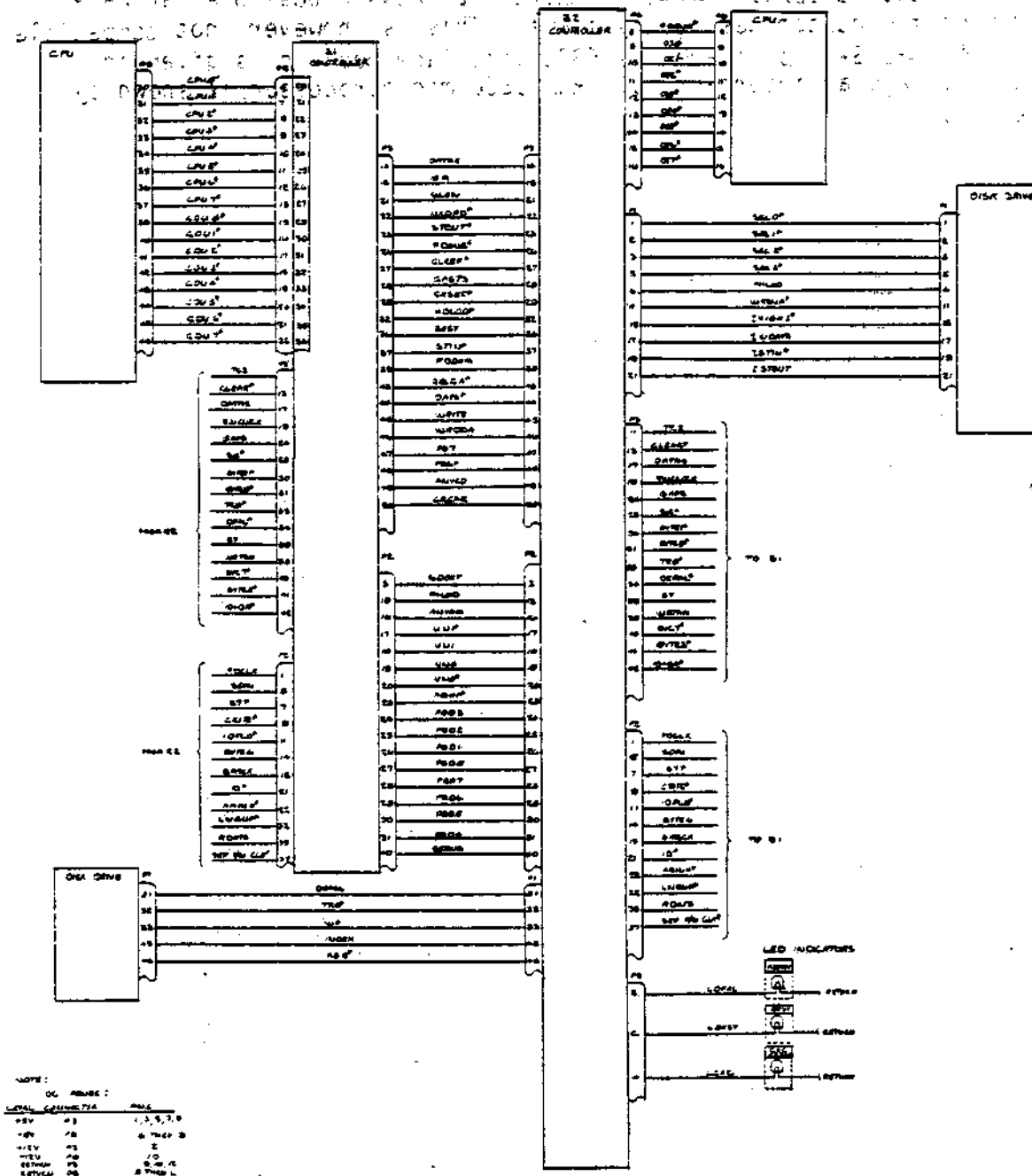

Figure 3-4. Signal Flow Diagram

SECTION IV

INTERFACING DIAGRAMS

This section offers typical diagrams for the interfacing requirements for various microprocessors. Figure 4-1 depicts the interface for iCOM's FDOS-II OEM software. Figure 4-2 shows a possible hardware arrangement for custom designed systems. This is, however, not compatible with iCOM's FDOS-II software. A 6800 interface hook-up is given in figure 4-3. And an interface to a RCA 1800 microprocessor is shown by figure 4-4.

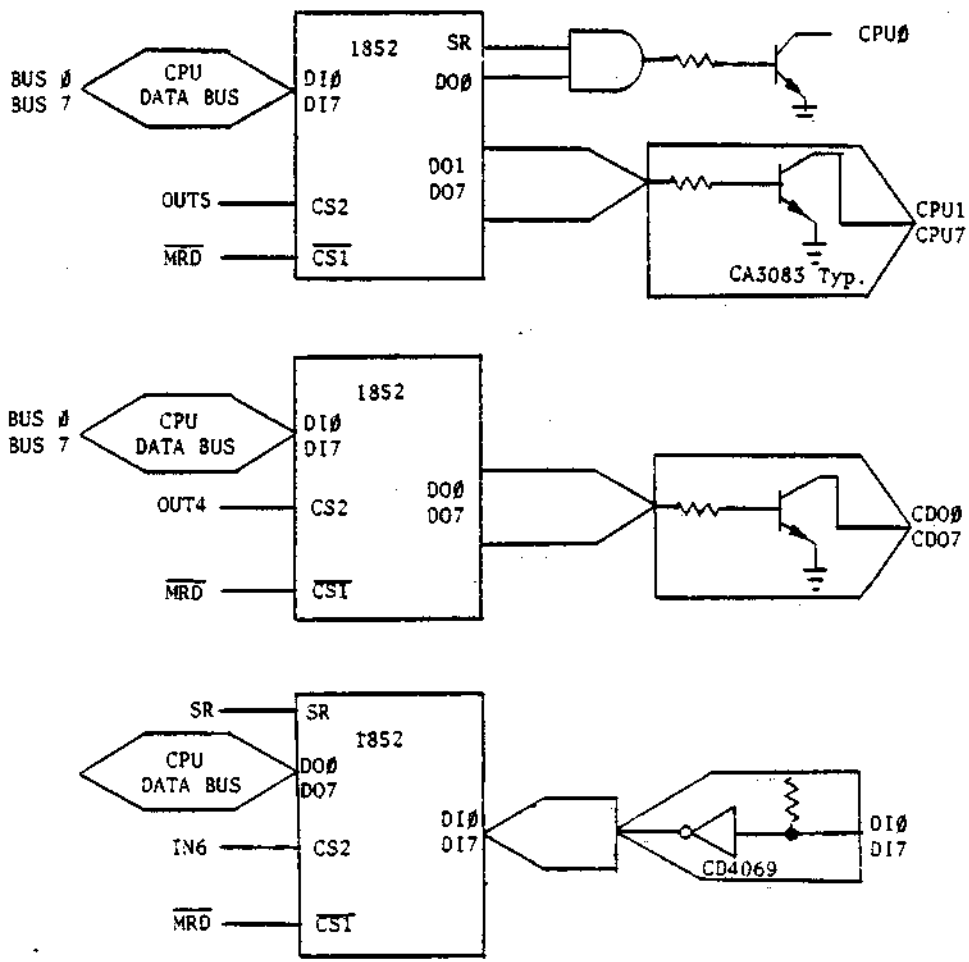

Figure 4-4. RCA 1800 Interfacing Diagram