

1-1. GENERAL

This SPECIFICATION provides a description for the TEAC FD-55GFR, 5.25", high/normal densities, double sided mini flexible disk drive (hereinafter referred to as the FDD). Table 100 shows the outline of the FDD.

Model name	FD-55GFR-340	FD-55GFR-440	FD-55GFR-540
TEAC P/N	19307273-40	19307274-40	19307275-40
Safety standard on label	-	UL	UL & CSA
Unformatted data capacity	1.6M/1.0M bytes		
Track density	96tpi		
Head load mechanism	Not equipped (CSS)		
Front bezel shape	TEAC standard		
Front lever shape	TEAC standard		
Bezel & lever color	Black		
LED indicator color	Red		
Pop-up mechanism	Not equipped		
Shield cover	Not equipped		
Frame ground terminal	Faston 187 tab		
Input signal terminator	330Ω ± 5% on IC socket		
Customer selectable straps	D0 ~ D3, U0, U1, IU, ML, RY, DC2, LG, E2, I/II/IS, FG Refer to item 1-11.		
Strap setting at shipment	D1, U1, DC2, II, FG		
Other optional functions & mechanism	Not equipped		

(Table 100) Specification outline

The FDD is equipped with an input signal for switching high/normal densities on the terminal No.2 of the signal interface connector. When the high density mode is designated, the FDD operates like conventional 8 inch, double sided double density FDD in data capacity and data transfer rate with high density mini flexible disk. When the normal density is designated, the FDD operates like conventional 5.25", 96tpi, double sided FDD. It can read and write the data of 5.25", 96tpi, single/double sided flexible disks, and it can also read the data of conventional 5.25", 48tpi, single/double sided disks. For the normal density mode, two disk rotational speeds are offered for selection using internal switching strap (short bar). One is 300rpm which is currently used in 5.25" FDDs and the other is 360rpm which is the same speed as in high density mode (also the same as in 8" FDDs).

Table 101 shows the summary of the FDD performance.

Speed mode	Density mode	Unformatted data capacity	Disk rotation speed	Data transfer rate/sec
Dual speed	High	1.6M bytes	360rpm	500K bits
	Normal	1.0M bytes	300rpm	250K bits
Single speed	High	1.6M bytes	360rpm	500K bits
	Normal	1.0M bytes	360rpm	300K bits

(Table 101)-Performance summary

1-2. DISK

130mm (5.25 inch) soft sectored high density flexible disks (for high density mode) or 130mm (5.25 inch) soft sectored normal density flexible disks (for normal density mode) which are mutually agreed between the customer and TEAC.

Since it is impossible for the FDD to identify which type of disks is installed, it is required for the host controller to provide some control such as detection of sector identifier or previous designation of the density.

1-3. PHYSICAL SPECIFICATION

- (1) Width: 146mm (5.75 in), Nom.
- (2) Height: 41.3mm (1.63 in), Nom.
- (3) Depth: 203mm (7.99 in), Nom.
(excludes projections of interface connectors)
- (4) Weight: 1.1Kg (2.43 lbs), Nom., 1.2Kg (2.65 lbs), Max.
- (5) External view: See Fig.101
- (6) Cooling: Natural air cooling
- (7) Mounting: Mounting for the following directions are acceptable.
 - (a) Front loading, mounted vertically.
 - (b) Front loading, mounted horizontally with indicator up. Do not mount horizontally with spindle motor up.
 - (c) Mounting angle in items (a) and (b) should be less than 15° with front bezel up.

Note: As to the other mounting directions than the above will be considered separately.
- (8) Installation: With installation holes on the side frame or on the bottom frame of the FDD (See Fig.101).
- (9) Material, Frame: Aluminum diecast
Front bezel: PPHOX (Xyron)

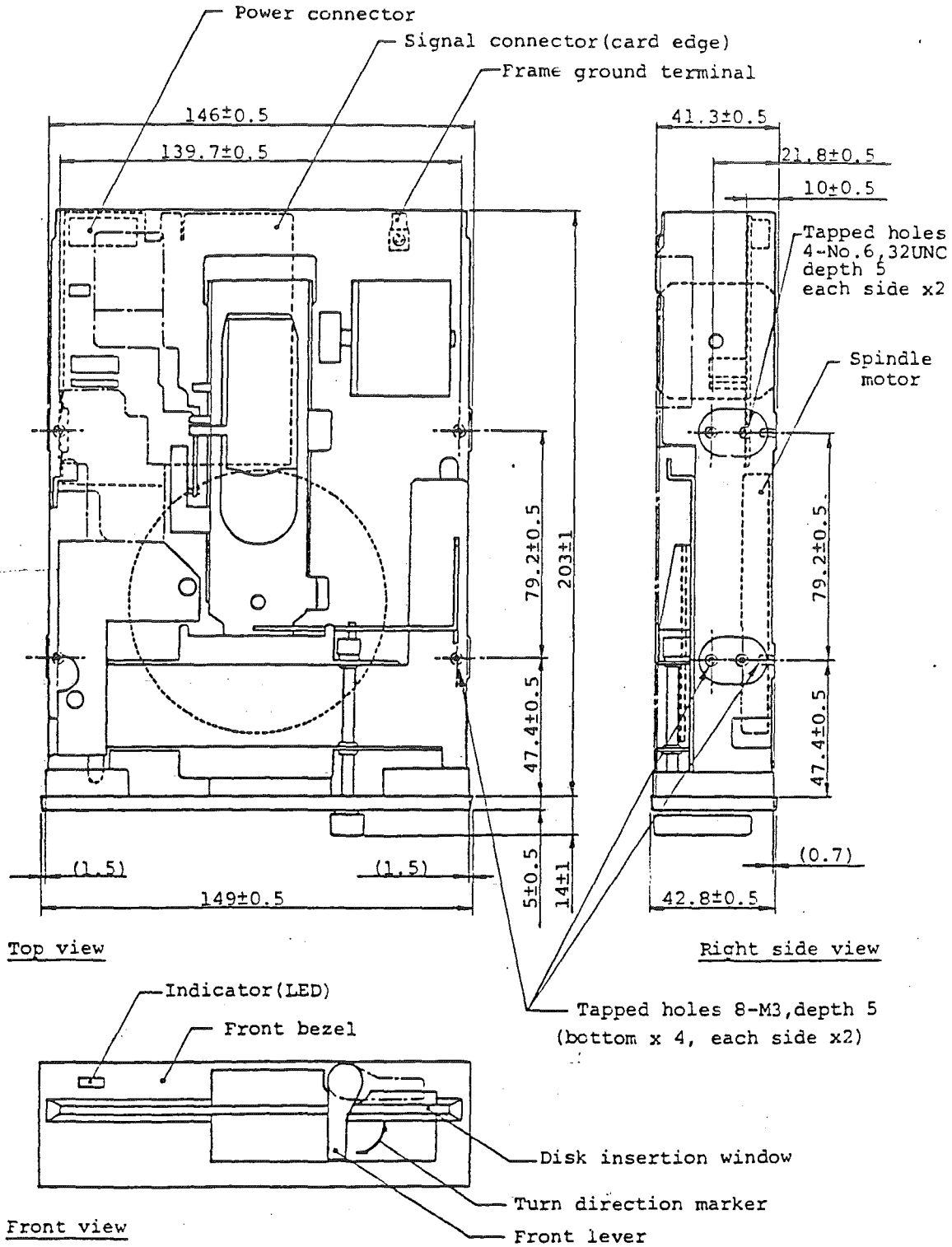

(Fig.101) External view

(Units:mm)

1-4. REQUIRED POWER

The following specifications are applicable at the power connector of the FDD.

(1) DC+12V

(a) Voltage tolerance

Read/write operation: Less than $\pm 5\%$

Others : Less than $\pm 10\%$

(b) Allowable ripple voltage: Less than 200mVp-p (including noise)

(c) Operating current consumption

Typical average: 0.22A

(using a disk of typical running torque)

Maximum average: Less than 0.54A

(using a disk of maximum running torque)

Peak: Less than 1.0A (400msec, Max. at spindle motor start)

(d) Waiting current consumption (spindle motor off)

Typical: 0.03A

Maximum: 0.04A

(2) DC+5V

(a) Voltage tolerance: $\pm 5\%$

(b) Allowable ripple voltage: Less than 100mVp-p (including noise)

(c) Operating current consumption

Typical average: 0.30A

Maximum average: Less than 0.38A

Peak: Less than 0.46A

(d) Waiting current consumption

Typical: 0.23A

Maximum: Less than 0.28A

(3) Power consumption

(a) Typical at operating: 4.1W

(b) Typical at waiting: 1.5W

(4) Power on sequence

Not specified (refer to Note below). Since the FDD is equipped with power reset circuit, disk and data on the disk will not be damaged by power on or off.

Note: If +12V power is turned on more than 320msec after the +5V power, auto-recalibration might not be executed. In such a case, execute ordinary recalibrate operation by commands from host side after turning on both powers.

(5) Power reset time in FDD: Less than 400msec,

Including general power resetting of internal circuit and auto-recalibration.

1-5. ENVIRONMENTAL CONDITIONS

(1) Ambient temperature

(a) Operating: 4°C ~ 46°C (40°F ~ 115°F)

(b) Storage: -22°C ~ 60°C (-8°F ~ 140°F)

(c) Transportation: -40°C ~ 65°C (-40°F ~ 149°F)

(2) Temperature gradient

(a) Operating: Less than 15°C (27°F) per hour

(b) Transportation and storage: Less than 30°C (54°F) per hour

(3) Relative humidity

(a) Operating: 20% ~ 80% (no condensation)

Maximum wet bulb temperature shall be 29°C (84°F)

(b) Storage: 10% ~ 90% (no condensation)

Maximum wet bulb temperature shall be 40°C (104°F)

(c) Transportation: 5% ~ 95% (no condensation)

Maximum wet bulb temperature shall be 45°C (113°F)

(4) Vibration

(a) Operating: Less than 0.5G (less than 55Hz)

Less than 0.25G (55 ~ 500Hz)

(b) Transportation: Less than 2G (less than 100Hz)

(5) Shock

(a) Operating: Less than 10G (less than 10msec)

(b) Transportation: Less than 40G (less than 10msec)

(6) Altitude

(a) Operating: Less than 5,000m (16,500 feet)

(b) Transportation: Less than 12,000m (40,000 feet)

Note: The above requirements are applied for the FDD without shipping box.
When a long period is required for transportation such as by ship,
the storage environmental conditions shall be applied.

1-6. OPERATIONAL CHARACTERISTICS

(1) Data capacity

Recording method		FM	MFM	
Data transfer rate (K bits/sec)		250	500	
Tracks/disk		154 (160)	154 (160)	
Innermost track bit density (bpi)		4,823 (4,935)	9,646 (9,870)	
Innermost track flux density (frpi)		9,646 (9,870)	9,646 (9,970)	
Data capacity	Unformatted	K bytes/track	5.208	10.416
		K bytes/disk	802	1,604
	Formatted 26 sectors /track	K bytes/sector	0.128	0.256
		K bytes/track	3.328	6.656
		K bytes/disk	512.5 (532.5)	1,025.0 (1,065.0)
	Formatted 15 sectors /track	K bytes/sector	0.256	0.516
		K bytes/track	3.840	7.680
		K bytes/disk	591.4 (614.4)	1,182.7 (1,228.8)
	Formatted 8 sectors /track	K bytes/sector	0.512	1.024
		K bytes/track	4.096	8.192
		K bytes/disk	630.8 (655.4)	1,261.6 (1,310.7)

Note: Up to 80 cylinders are available for the FDD. The figures in the blackets are for 80 cylinder's operation (160 tracks).

(Table 102) High density mode data capacity

Recording method			FM	MFM
Data transfer rate (K bits/sec)	Dual speed (300rpm)		125	250
	Single speed (360rpm)		150	300
Tracks/disk			160	160
Innermost track bit density (bpi)			2,961	5,922
Innermost track flux density (frpi)			5,922	5,922
Data capacity	Unformatted	K bytes/track	3.125	6.25
		K bytes/disk	500	1,000
	Formatted 16 sectors /track	K bytes/sector	0.128	0.256
		K bytes/track	2.048	4.096
		K bytes/disk	327.68	655.36

(Table 103) Normal density mode data capacity

(2) Disk rotation mechanism

- (a) Spindle motor: Direct DC brushless motor
- (b) Spindle motor speed
 - Dual speed mode: 360rpm (high density)/300rpm (normal density)
 - Single speed mode: 360rpm (high and normal densities)
- (c) Motor servo method: PLL servo or frequency servo by AC tachometer
- (d) Motor/spindle connection: Motor shaft direct
- (e) Disk speed: The same as the spindle motor speed
 - Long term speed variation (LSV): Less than $\pm 1.5\%$
 - Instantaneous speed variation (ISV): Less than $\pm 1.5\%$
- (f) Start time, 360rpm: Less than 500msec
 - 300rpm: Less than 400msec
- (g) Average latency, 360rpm: 83.3msec
 - 300rpm: 100msec
- (h) Speed change time (360rpm \rightleftharpoons 300rpm): Less than 400msec
 - Note: This item is applied only for dual speed mode.

(3) Index

- (a) Number of index: 1 per disk revolution
- (b) Detection method: LED and photo-transistor
- (c) Detection cycle, 360rpm: 166.7msec $\pm 1.5\%$
300rpm: 200msec $\pm 1.5\%$
- (d) Index burst detection timing tolerance (with specified test disk)
360rpm: $\pm 165\mu\text{sec}$, Max.
300rpm: $\pm 200\mu\text{sec}$, Max.

(4) Track construction

- (a) Track density: 96tpi
- (b) Number of cylinders. high density mode: 77 (80) cylinders
normal density mode: 80 cylinders
- (c) Number of tracks, high density mode: 154 (160) tracks
normal density mode: 160 tracks
- (d) Outermost track radius (track 00): Side 0 57.150mm (2.2500 in)
Side 1 55.033mm (2.1667 in)
- (e) Innermost track radius
For 77 cylinders (track 76): Side 0 37.042mm (1.4583 in)
Side 1 34.925mm (1.3750 in)
For 80 cylinders (track 79): Side 0 36.248mm (1.4271 in)
Side 1 34.131mm (1.3438 in)
- (f) Positioning accuracy: Less than $\pm 20\mu\text{m}$, with specified test disk
(Track 32, 23 $\pm 2^\circ\text{C}$, 40 \sim 60%RH)

(5) Magnetic head

- (a) Magnetic head: Flexure supported read/write head with tunnel erase,
2 sets.
- (b) Effective track width: $0.155 \pm 0.015\text{mm}$ (0.0061 ± 0.0006 in)
- (c) Read/write-erase gap spacing: 0.585mm (0.0230 in), Nom.
- (d) Read/write gap azimuth: $0^\circ \pm 18'$, with specified test disk.

(6) Track seek mechanism

(6) Track seek mechanism

- (a) Head carriage drive mechanism: Stepping motor and steel belt
- (b) Stepping motor: 4-phase, 200 steps per revolution
- (c) Stepping motor drive: 1 step per track
- (d) Track 00 and innermost stopper: Mechanical moving stopper of head carriage
- (e) Track 00 detection method: LED and photo-transistor
- (f) Track to track time: Use 3msec, Min.
- (g) Settling time: Less than 15msec (excludes track to track time)
- (h) Average track access time (includes settling time)
 - For 77 cylinders: 91msec
 - For 80 cylinders: 94msec
- (i) Auto-recalibration:

Auto-recalibration is executed (head moves to track 00 automatically) immediately after power-on. The FDD maintains not-ready state and ignores STEP command during the auto-recalibration.

Refer to item 1-4 (5).

(7) Head load mechanism: Not equipped

(When a disk is inserted and the door is closed, the FDD becomes head load condition).

(8) File protect mechanism: Detection of write protect notch by LED and photo-transistor

(9) Window margin (shipping) with specified test disk, MFM method, PLO separator, and zero write pre-compensation:

- High density mode: More than 300nsec
- Normal density mode, 360rpm: More than 500nsec
- 300rpm: More than 600nsec

(10) Disk in place detection method: LED and photo-transistor.

1-7. RELIABILITY

- (1) MTBF: 10,000 power on hours or more (for typical usage)
- (2) MTTR: 30 minutes
- (3) Design component life: 5 years
- (4) Preventive maintenance: Not required (for typical usage)
- (5) Error rates
 - (a) Soft read error: 1 per 10^9 bits (up to 2 retries)
 - (b) Hard read error: 1 per 10^{12} bits
 - (c) Seek error: 1 per 10^6 seeks
- (6) Safety standard: Complying with UL, CSA

Warning: EMI/RFI countermeasure

This FDD generates and uses radio frequency energy. If the FDD (including the interface cable and connector) is used without shielding, it may cause interference to radio and television reception around it. Be sure to install this FDD in the equipment which is designed for effective EMI/RFI countermeasure.

This FDD installed in a specific equipment has been type tested and found to comply with the limits for a Class B computing device in accordance with the specifications in Subpart J of Part 15 of FCC Rules, which are designed to provide reasonable protection against such interference in a residential installation.

However, there is no guarantee that interference will not occur in a particular installation. If the equipment with this FDD does cause interference to radio or television reception, which can be determined by turning the equipment off and on, the user is encouraged to try to correct the interference by one or more of the following measure.

- a) Reorient the receiving antenna.
- b) Relocate the equipment with respect to the receiver.
- c) Move the equipment away from the receiver.
- d) Plug the equipment into a different outlet so that the equipment and the receiver are on different branch circuits.

1-8. SIGNAL INTERFACE

1-8-1. Electrical Characteristics

(1) Interface driver/receiver: See Fig.102.

(2) Electrical characteristics

The following specifications are applicable at the signal connector of the FDD.

(a) Input signal

LOW level (TRUE): 0V ~ 0.5V

Terminator current: $\frac{5.25 \times 1,000}{\text{Terminator resistor value}}$ mA, Max.

Receiver current: 0.4mA, Max.

HIGH level (FALSE): 2.5V ~ 5.25V

(b) Output signal

LOW level (TRUE): 0V ~ 0.4V

Driver sink current capability: 48mA, Max.

HIGH level (FALSE): 5.25V, Max.

(depending on host side terminator)

(3) Terminator

(a) Resistor value: See Table 100 in item 1-1.

(b) Terminator for DRIVE SELECT 0 ~ 3 input signals:

A terminator resistor is mounted on the PCB with soldering joint.

(c) Terminator for other input signals:

A resistor network is mounted on IC socket on the PCB.

(d) Shipping condition

All of the terminator resistors are mounted.

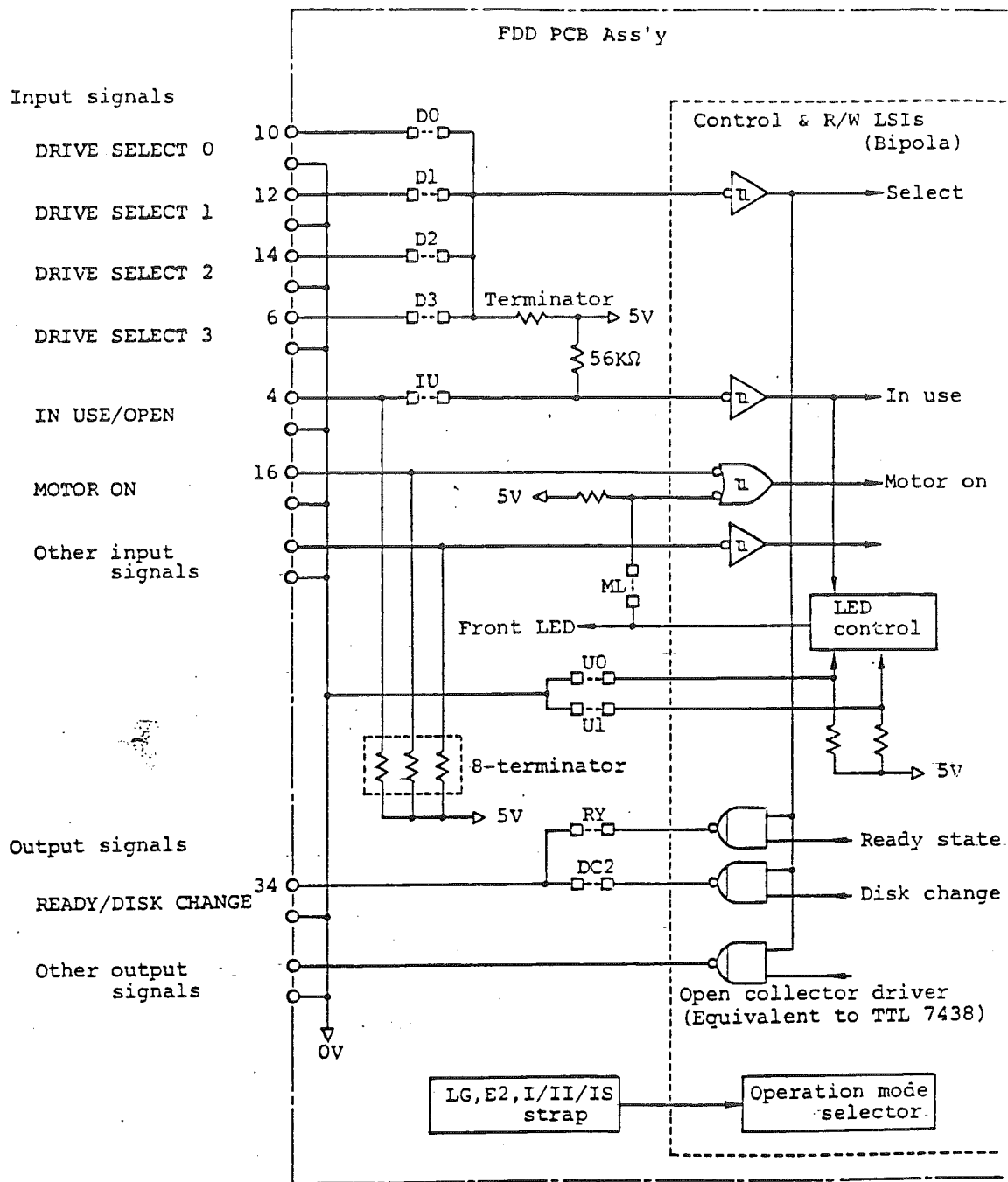

(Fig.102) Signal interface circuit

1-8-2. Signal Connector and Cable

(1) Signal connector

- (a) FDD side connector: Card edge of the main PCBA
- (b) Pin numbers & pin pitch: 34 pins, 2.54mm (0.1 in) pitch
(17 pins on both sides, even number pins are bottom side of the FDD)
- (c) Polarizing key location: Between pins 4 and 6
- (d) Card edge dimensions: See Fig.103
- (e) Interface connections: See Table 102
- (f) Cable side matched connector:
3M, Scotchflex ribbon connector, P/N 3463-0001
or AMP, thin leaf connector, P/N 583717-5 and contactor P/N 1-583616-1
or equivalent.

(2) Maximum interface cable length:

For the multiplex connection by daisy chaining, the total cable length should be less than as follows:

e.g.: 3m, Max. for 330 Ω terminator, 1.5m, Max. for 1K Ω terminator

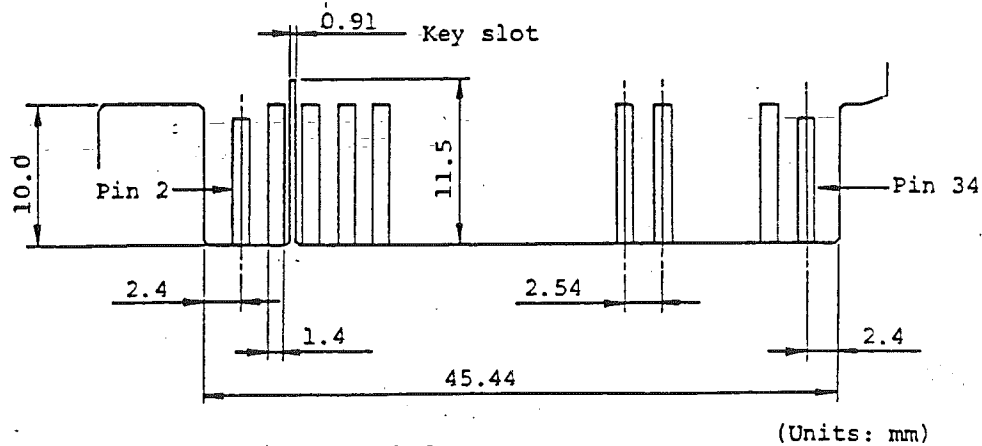

Notes: 1. PCB thickness: 1.6mm, Nom.

2. The figure shows bottom view of the FDD.

(Fig.103) Card edge dimensions of signal connector

Signals	Directions	Terminal Nos.	
		Signals	OV
HIGH/NORMAL DENSITY	INPUT	2	1
IN USE/OPEN	INPUT	4	3
DRIVE SELECT 3	INPUT	6	5
INDEX	OUTPUT	8	7
DRIVE SELECT 0	INPUT	10	9
DRIVE SELECT 1	INPUT	12	11
DRIVE SELECT 2	INPUT	14	13
MOTOR ON	INPUT	16	15
DIRECTION SELECT	INPUT	18	17
STEP	INPUT	20	19
WRITE DATA	INPUT	22	21
WRITE GATE	INPUT	24	23
TRACK 00	OUTPUT	26	25
WRITE PROTECT	OUTPUT	28	27
READ DATA	OUTPUT	30	29
SIDE ONE SELECT	INPUT	32	31
READY/DISK CHANGE	OUTPUT	34	33

(Table 104) Signal interface connections

1-8-3. Input/Output Signals

In the following, input signals are those transmitted to the FDD while output signals are those transmitted from the FDD. Refer to item 1-12 as to the relation between input signals and operating conditions of the front bezel indicator and spindle motor. LOW level of the signals is TRUE.

(1) DRIVE SELECT 0 ~ 3 input signals

- (a) Signals of four lines to select a specific FDD for operating in multiplex control by daisy chaining.
- (b) Only the DRIVE SELECT signal of the same number as of on-state strap among D0 ~ D3 straps is effective.
- (c) All the input/output signals except for the MOTOR ON, IN USE, and HIGH/NORMAL DENSITY signals are effective when this signal is effectively received.
- (d) The time required to make each input or output signal effective after the transmission of this signal is 0.5μsec, Max. including delay time through the interface cable.

(2) MOTOR ON input signal

- (a) Level signal to rotate the spindle motor.
- (b) The spindle motor reaches to the rated rotational speed within 500msec (at 360rpm) or 400msec (at 300rpm) after this signal changes to TRUE.
- (c) Rotational speed is switched between 360rpm and 300rpm according to the HIGH/NORMAL DENSITY signal only when the dual speed mode is selected. Refer to items 1-11 and 1-12-3.

(3) DIRECTION SELECT input signal

- (a) Level signal to define the moving direction of the head when the STEP line is pulsed.

- (b) Step-out (moving away from the center of the disk) is defined as HIGH level of this signal. Conversely, step-in (moving toward the center of the disk) is defined as LOW level of this signal.

(4) STEP input signal

- (a) Pulse signal to move the head. The pulse width shall be more than $0.8\mu\text{sec}$ and the head moves one track space per one pulse.
- (b) The access motion (head seek operation) is initiated at the trailing edge of a STEP pulse. For the subsequent motion in the same direction, the pulses should be input with an interval of more than 3msec, while the pulses should be input with an interval of more than 10msec for a direction change.
- (c) This signal is ineffective when the WRITE PROTECT signal is FALSE and the WRITE GATE signal is TRUE.
Also this signal is ineffective when the TRACK 00 signal is TRUE and the DIRECTION SELECT signal is HIGH level (step-out).
- (d) This signal shall be input according to the timing in Fig.104.

(5) WRITE GATE input signal

- (a) Level signal to erase the written data and to enable the writing of new data.
- (b) The FDD is set to write mode when the following logical expression is satisfied.
$$\text{WRITE GATE} * \text{DRIVE SELECT} * \text{WRITE PROTECT}$$
- (c) This signal should be made TRUE after satisfying all of the following conditions.
 - i) The FDD is in ready state (refer to item (13)).
However, the host controller can ignore this item since the INDEX and the READ DATA pulses are output only when the FDD is in ready state.
 - ii) More than 18msec after the effective receipt of the final STEP pulse.

iii) More than 100 μ sec after the level change of the SIDE ONE SELECT signal.

iv) More than 400msec after the level change of the HIGH/NORMAL DENSITY signal.

(This item is applied only to the dual speed mode).

(d) None of the following operation should be done for at least 590 μ sec (at 360rpm) or 1msec (at 300rpm) after this signal is changed to FALSE.

i) Make a motor-on command FALSE.

ii) Make the DRIVE SELECT signal FALSE.

iii) Start the head seek operation by the STEP pulse.

iv) Change the level of the SIDE ONE SELECT signal.

v) Change the level of the HIGH/NORMAL DENSITY signal.

(This item is applied only to the dual speed mode).

(6) WRITE DATA input signal

(a) Pulse signal to designate the contents of data to be written on a disk. The pulse width should be 0.07 \sim 1.1 μ sec (at high density mode) or 0.07 \sim 2.1 μ sec (at normal density mode) and the leading edge of the pulse is used.

(b) This signal is ineffective while either of the following condition is satisfied.

i) The WRITE GATE signal is FALSE.

ii) The WRITE PROTECT signal is TRUE.

(c) This signal shall be input according to the timing in Fig.105.

(7) SIDE ONE SELECT input signal

(a) Level signal to designate which side of a double sided disk is used for reading or writing.

(b) When this signal is HIGH level, the magnetic head on the side 0 surface of the disk is selected, while the magnetic head on the side 1 surface is selected when this signal is LOW level.

- (c) The READ DATA pulse on a selected surface is valid more than 100µsec after the change of this signal level.
- (d) Write operation (the WRITE GATE signal is TRUE) on a selected surface shall be started more than 100µsec after the change of this signal level.
- (e) When the other side of a disk is selected after the completion of a write operation, the level of this signal shall be switched more than 590µsec (at 360rpm) or 1msec (at 300rpm) after making the WRITE GATE signal FALSE.

(8) IN USE/OPEN input signal

This signal is effective only when the IU strap is on-state. Refer to item 1-11.

- (a) Level signal to indicate that all of the daisy chained FDDs are in use condition under the control of the host system. Refer to item 1-12.
- (b) When the IU strap is off-state, only the terminator is connected to pin 4 of the signal interface connector and the input circuit becomes open condition. Refer to Fig.102.

(9) TRACK 00 output signal

- (a) Level signal to indicate that the head is on track 00 (the outermost track).
- (b) This signal is valid more than 2.8msec after the effective receipt of the STEP pulse.

(10) INDEX output signal

- (a) Pulse signal to indicate the start point of a track and one INDEX pulse per one disk revolution is output.
- (b) INDEX pulse is output when the following logical expression is satisfied.

Index hole detection * DRIVE SELECT * Ready state * Seek-complete

Notes: 1. Seek-complete means the state that more than 15msec through 17msec has been passed after the trailing edge of the final STEP pulse.

2. Refer to item 1-11 "E2 strap" as to the output condition change of the INDEX pulse.

- (c) Fig.106 shows the timing of this signal. Leading edge of the pulse shall be used as the reference and all the output pulses are valid.

(11) READ DATA output signal

- (a) Pulse signal for the read data from a disk composing clock bits and data bits together.
- (b) Fig.107 shows the timing for this signal. Leading edge of the pulse shall be used as the reference.
- (c) READ DATA pulse is output when the following logical expression is satisfied.

Read data detection * DRIVE SELECT * Ready state * Write operation
* Seek-complete

Notes: 1. Seek-complete means the state that 15msec through 17msec has been passed after the trailing edge of the final STEP pulse.

2. Write operation means the state that the WRITE GATE signal is FALSE and more than the erase delay time (1msec, Max. at 300rpm or 590µsec, Max. at 360rpm), has been passed after the WRITE GATE signal changed to FALSE.

3. Refer to item 1-11 "E2 strap" as to the output condition change of the READ DATA pulse.

(d) Output pulse is valid when all of the following conditions are satisfied.

- i) More than 18msec after the effective receipt of the final STEP pulse.
- ii) More than 590µsec (at 360rpm) or 1msec (at 300rpm) after the WRITE GATE signal becomes FALSE.
- iii) More than 100µsec after the level change of the SIDE ONE SELECT signal.
- vi) More than 400msec after the level change of the HIGH/NORMAL DENSITY signal.

(This item is applied only to the dual speed mode).

(12) WRITE PROTECT output signal

- (a) Level signal to indicate that the write enable notch of the disk is masked.
- (b) When this signal is TRUE, the data on the disk are protected from erasing and writing of new data is inhibited.

(13) READY/DISK CHANGE output signal

This signal has either READY or DISK CHANGE function by selecting the RY/DC2 strap. Refer to Fig.102 and items 1-11 and 1-12-3.

(13-1) When READY function is selected:

- (a) Level signal to indicate that the FDD is in ready state.
- (b) The FDD goes to the ready state when all of the following conditions are satisfied.

- i) The FDD is powered on and a disk is installed.
 - ii) A motor-on command from the host side is TRUE and 500msec has been passed.
 - iii) The disk rotates at more than 80% of the rated speed and two INDEX pulses have been counted.
 - iv) INDEX pulse width is less than 13msec.
- (c) The FDD goes to the ready state within 730msec (at 360rpm) or within 800msec (at 300rpm) after making a motor-on command TRUE. 510msec, approx. in average.
 - (d) The ready state is reset within 0.3msec after changing the level of a motor-on command to FALSE.
 - (e) INDEX and READ DATA output signals maintain FALSE while the FDD is not in the ready state.
 - (f) When the dual speed mode is selected with the I strap being on-state, the FDD is reset to not-ready state within 30µsec after the level change of the HIGH/NORMAL DENSITY input signal. If a motor-on command maintains TRUE at that time, the FDD returns to ready state within 600msec again.
 - (g) When the single speed mode is selected or when the dual speed mode is selected with the IS strap being on-state, FDD maintains the ready state with no relation to the level change of the HIGH/NORMAL DENSITY input signal. Refer to items 1-11 and 1-12-3.
- (13-2) When DISK CHANGE function is selected:
- (a) Level signal to indicate that an installed disk is removed (disk change state).
 - (b) This signal goes to TRUE when either of the following conditions are satisfied.
 - i) Power on.
 - ii) Disk is removed.
 - (c) This signal returns to FALSE when both of the following conditions are satisfied.
 - i) Disk is installed.
 - ii) A STEP pulse is received when the DRIVE SELECT signal (selected

by D0 ~ D3 straps) is TRUE.

(14) HIGH/NORMAL DENSITY input signal

- (a) Level signal to switch the operation mode of the FDD.
- (b) When the LG strap is on-state, the LOW level of this signal designates the high density mode, while the HIGH level designates the normal density mode.
- (c) When the LG strap is off-state, the LOW level of this signal designates the normal density mode, while the HIGH level designates the high density mode.
- (d) If the dual speed mode is selected, disk rotation speed is switched between 360rpm (high density mode) and 300rpm (normal density mode) according to this signal level.
- (e) If the single speed mode is selected, disk rotation speed is fixed to 360rpm independent of this signal level.

Note: Treatment of not-used signals

If some of the provided input/output signals are not necessary for your application, keep them open or connect appropriate pull-up resistor (more than 150Ω for an FDD output signal) at the host side.

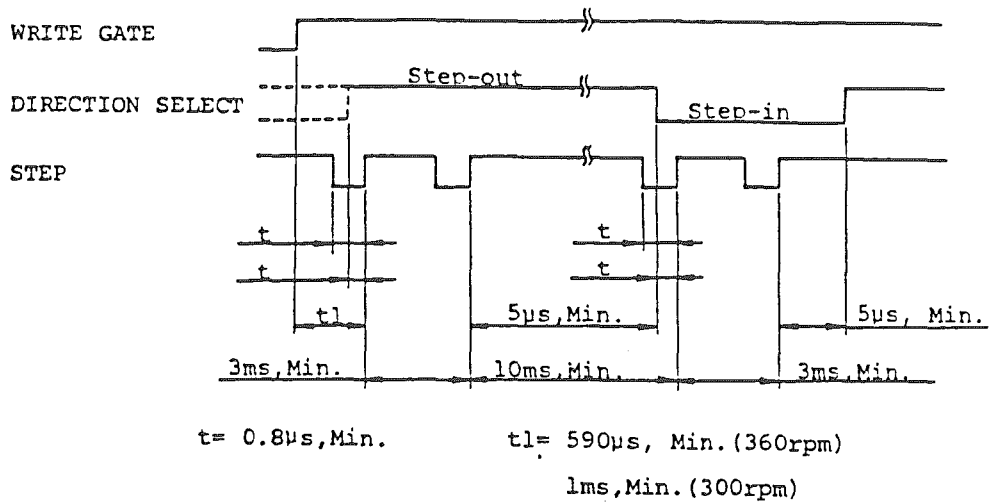

(Fig.104) STEP timing

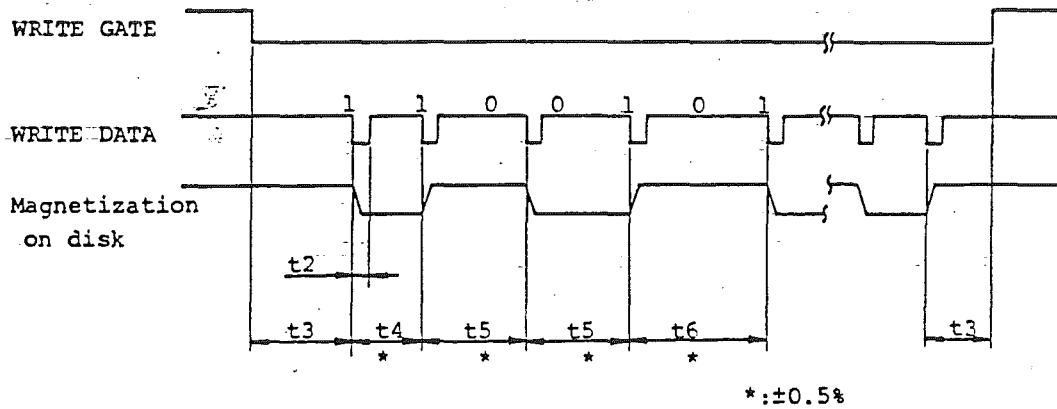

Density & Disk Speed	t2	t3	t4	t5	t6
High, 360rpm	0.07~1.1µs	4µs, Max.	2µs, Nom.	3µs, Nom.	4µs, Nom.
Normal, 360rpm	0.07~2.1µs	6.7µs, Max.	3.3µs, Nom.	5µs, Nom.	6.7µs, Nom.
Normal, 300rpm	0.07~2.1µs	8µs, Max.	4µs, Nom.	6µs, Nom.	8µs, Nom.

(Fig.105) WRITE DATA timing (MFM method)

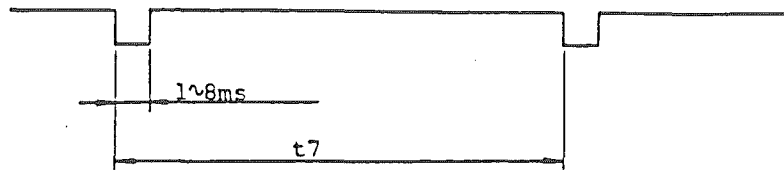

$t7 = 166.7 \pm 2.5 \text{ms}$ (360rpm)
 $200 \pm 3 \text{ms}$ (300rpm)

(Fig.106) INDEX timing

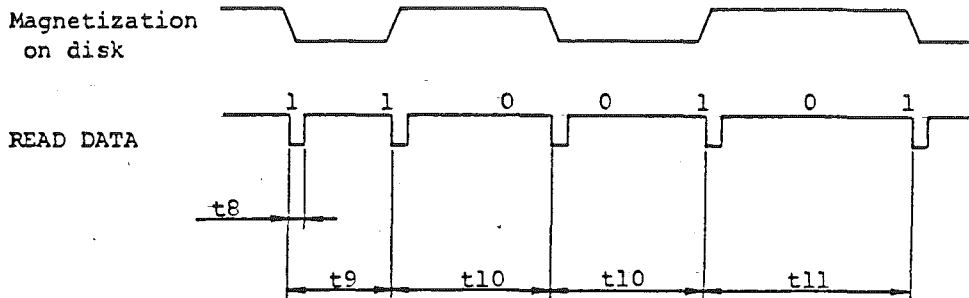

Note: The displacement of any bit position does not exceed "t12" from its nominal position. (When PLO separator is used with zero write pre-compensation.)

Density & Disk speed	t8	t9	t10	t11	t12
High, 360rpm	$0.5 \pm 0.25 \mu\text{s}$	$2 \mu\text{s, Nom.}$	$3 \mu\text{s, Nom.}$	$4 \mu\text{s, Nom.}$	$\pm 350 \text{ns}$
Normal, 360rpm	$0.5 \pm 0.25 \mu\text{s}$	$3.3 \mu\text{s, Nom.}$	$5 \mu\text{s, Nom.}$	$6.7 \mu\text{s, Nom.}$	$\pm 580 \text{ns}$
Normal, 300rpm	$0.5 \pm 0.25 \mu\text{s}$	$4 \mu\text{s, Nom.}$	$6 \mu\text{s, Nom.}$	$8 \mu\text{s, Nom.}$	$\pm 700 \text{ns}$

(Fig.107) READ DATA timing (MFM method)

1-9. POWER INTERFACE

Refer to item 1-4 for power requirements.

(1) Power connector

- (a) FDD side connector: AMP, Mate-N-Lock connector, P/N 172349-1
or equivalent
- (b) Pin numbers: 4 pins
- (c) Protection method for mis-connection: Mechanical protection by the
shape of the connector housing.
- (d) Pin location: See Fig.108
- (e) Power interface connections: See Table 105
- (f) Cable side matched connector: AMP, P/N 1-480424-0 and pins 60617-1,
or 60619-1,
or equivalent

(2) Power cable

Any appropriate cables taking the maximum power consumption of the FDD and the power voltage at the connector into consideration will be acceptable.

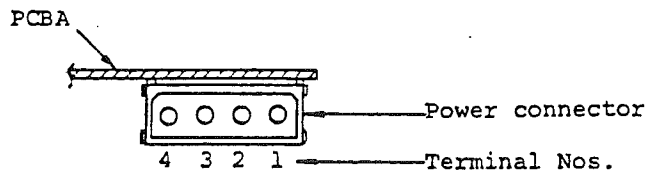

(Fig.108) Power connector pin location (rear view)

Voltage	Terminal Nos.
DC+12V	1
0V	2
0V	3
DC+5V	4

(Table 105) Power interface connections

1-10. FRAME GROUNDING

(1) Frame grounding

- (a) The FDD frame is electrically connected to DC 0V by FG strap on the main PCBA. (See Fig.109).
- (b) The FDD is shipped with the FG strap set to on-state.
- (c) Insulation resistance between the frame and DC 0V is more than $150K\Omega$ at DC 150V, if the FG strap is set to off-state.

(2) Frame ground terminal (back side of the FDD)

- (a) FDD side terminal: AMP Faston 187 tab P/N 61761-2
or equivalent
- (b) Cable side-matched terminal: AMP P/N 60972-2 or 61697-1
or equivalent

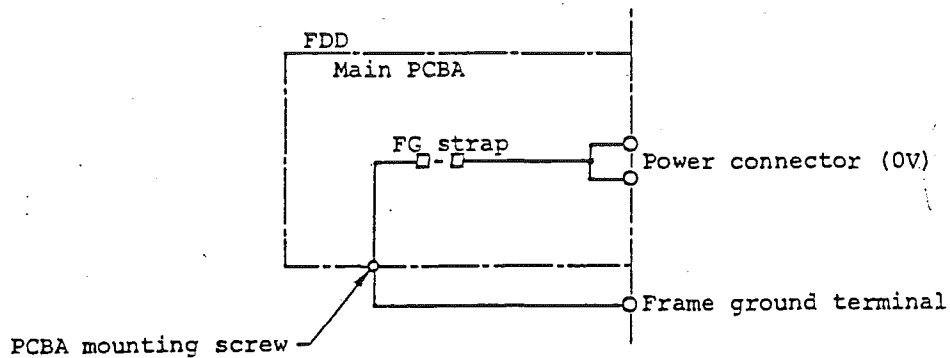

(Fig.109) Frame ground internal connection

1-11. CUSTOMER SELECTABLE STRAPS

All the straps are mounted on the main PCBA of the FDD. Insertion of a short bar onto the post pin is defined as the on-state of the strap. Fig.110 shows the assignment of the straps on the PCBA.

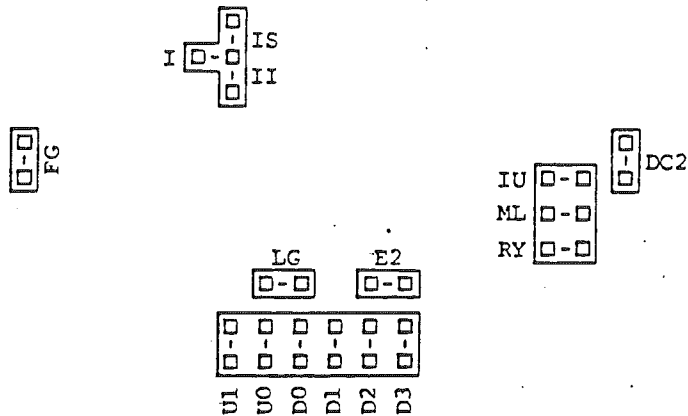

(Fig.110) Assignment of straps

(1) Straps setting at shipment

See Table 100 in item 1-1.

(2) D0 ~ D3 straps

- (a) In the multiplex control by daisy chaining, these straps designate the address of the FDD.
- (b) By the combination with the DRIVE SELECT 0 ~ 3 signals, four addresses of 0 through 3 can be designated. Refer to Fig.102 and item 1-8-3 (1). Never designate more than 2 FDDs to a same address.

(3) U0 and U1 straps

- (a) Straps to select the turn-on condition of the front bezel indicator.

(b) Five turn-on conditions can be selected including the IU strap in item (4). Refer to item 1-12-1.

(4) IU strap

- (a) Strap to make the signal interface terminal 4 be used for the IN USE input signal.
- (b) When this strap is off-state the input circuit is open and the IN USE input signal is ineffective. Refer to Fig.102.

(5) ML strap

- (a) Strap to select the rotational condition of the spindle motor by an external command.
- (b) When this strap is off-state, the spindle motor rotates only by the MOTOR ON input signal.
- (c) When this strap is on-state, the spindle motor rotates by either of the following conditions. (Refer to item 1-12-2).
 - i) While the MOTOR ON input signal is TRUE.
 - ii) While the front bezel indicator turns on.

(6) RY and DC2 straps

- (a) Straps to select the function of the READY/DISK CHANGE output signal (signal interface terminal 34).
- (b) When the RY strap is on-state, the signal of terminal 34 functions as the READY signal, while it functions as the DISK CHANGE signal when the DC2 strap is on-state. Refer to item 1-8-3 (13).

(7) LG strap

- (a) Strap to select the meaning of the HIGH/NORMAL DENSITY input signal level.
- (b) When this strap is on-state, the LOW level of the HIGH/NORMAL DENSITY

signal designates the high density mode.

- (c) When this strap is off-state, the LOW level of the HIGH/NORMAL DENSITY signal designates the normal density mode.

(8) I/II/IS straps

- (a) Straps to select the speed mode of the FDD.
- (b) When the I strap is on-state, the dual speed mode is designated. Disk rotational speed is switched between 360rpm for the high density mode and 300rpm for the normal density mode according to the HIGH/NORMAL DENSITY signal. Also the ready state is reset once synchronizing with the HIGH/NORMAL DENSITY signal. Refer to item 1-8-3 (13-1).
- (c) When the II strap is on-state, the single speed mode is designated. Disk rotation speed is fixed to 360rpm independent of the HIGH/NORMAL DENSITY signal.
- (d) When the IS strap is on-state, the dual speed mode is selected like item (b). However, the FDD maintains the ready state with no relation to the HIGH/NORMAL DENSITY signal.
- (e) One of the I/II/IS straps should be set to on-state.

(9) E2 strap

- (a) Strap to select the output condition of the INDEX and the READ DATA pulses.
- (b) When this strap is off-state, these pulses are output as in items 1-8-3 (10) and (11).
- (c) When this strap is set to on-state, output conditions are changed to the following logical expression (not gated with seek-complete).
INDEX: Index hole detection * DRIVE SELECT * Ready state
READ DATA: Read data detection * DRIVE SELECT * Ready state
* Write operation

(10) FG strap

- (a) Strap to connect the FDD frame electrically to DC OV.
- (b) Refer to item 1-10 as to the details.

1-12. OPERATIONAL CONDITIONS

1-12-1. Front Bezel Indicator

Five turn-on conditions of the front bezel indicator are offered for selection using three straps, U0, U1, and IU as shown in Table 106.

Selection No.	Strap-combinations			Indicator turn-on conditions
	IU	U0	U1	
1	-	-	ON	DRIVE SELECT
2	ON	-	ON	DRIVE SELECT + IN USE
3	ON	ON	-	IN USE
4	-	ON	ON	DRIVE SELECT * READY
5	ON	ON	ON	IN USE + (DRIVE SELECT * READY)

Notes: 1. "-" mark indicates the off-state of the strap.

2. Other combinations not specified in table are not used practically.

(Table 106) Indicator turn-on conditions

(1) Selection No.1

The indicator turns on while the DRIVE SELECT signal (selected by D0 ~ D3 straps) is TRUE.

(2) Selection No.2

The indicator turns on while the DRIVE SELECT signal is TRUE or while the IN USE signal is TRUE.

(3) Selection No.3

The indicator turns on while the IN USE signal is TRUE.

(4) Selection No.4

The indicator turns on while the DRIVE SELECT signal is TRUE and the FDD is in ready state (refer to item 1-8-3 (13)).

(5) Selection No.5

The indicator turns on in the condition of item (3) or (4).

1-12-2. Spindle Motor

The spindle motor starts rotation in either of the following conditions (1) and (2).

(1) Rotation by a command from the host side

Either one of the following conditions can be selected by the ML strap.

(a) Selection 1: Off-state of ML strap

The spindle motor rotates while the following logical expression is satisfied.

MOTOR ON * Disk installed

(b) Selection 2: On-state of ML strap

The spindle motor rotates while the following logical expression is satisfied.

(MOTOR ON + Front bezel LED on) * Disk installed

Note that the Selection Nos. 4 and 5 of the turn-on conditions of the front bezel indicator (refer to item 1-12-1) cannot be used for this purpose.

(2) Automatic rotation by the internal circuit of the FDD

(a) Automatic rotation by the internal circuit will start when a disk is inserted into the front bezel.

(b) Automatic rotation will stop under one of the following conditions.

- i) When the front lever is closed, disk starts rotation, and the FDD goes to ready state. The READY signal maintains FALSE.
- ii) When a disk is removed.
- iii) In a rare case, when a disk is inserted at the index hole position and the front lever is not closed for 8.7 seconds, approx.

1-12-3. Operation Mode

Following operation modes are offered for selection using three strap blocks, LG, I/II/IS, and RY/DC2 as shown in Table 107.

Three strap blocks operate independently each other.

Strap blocks	ON	Operation modes
LG	LG	LOW level of HIGH/NORMAL DENSITY signal designates high density mode.
	-	LOW level of HIGH/NORMAL DENSITY signal designates normal density mode (write current is reduced).
I/II/IS	I	Dual speed mode is selected. Ready state is reset synchronizing with HIGH/NORMAL DENSITY signal. 360rpm: High density, 300rpm: Normal density
	II	Single speed mode is selected. 360rpm: High/normal densities
	IS	Dual speed mode is selected. Ready state maintains TRUE independently of HIGH/NORMAL DENSITY signal. 360rpm: High density, 300rpm: Normal density
RY/DC2	RY	READY output is selected for signal interface terminal 34.
	DC2	DISK CHANGE output is selected for signal interface terminal 34.

(Table 107) Selection of operation mode

OUTLINE

This specification provides a description for the TEAC FD-55GFR, 5.25", high /normal densities, double sided mini flexible disk drive (hereinafter referred to as the FDD).

Model name	FD-55GFR-7149	FD-55GFR-7193	FD-55GFR-7220
TEAC P/N	19307671-49	19307671-93	19307672-20
Bezel & lever color	Gray (PC-AT)	Beige (PS2)	Black
Safety standard on label	UL & CSA		
Unformatted data capacity	1.6M/1M bytes		
Track density	96tpi		
Head load mechanism	Not equipped. (CSS)		
Front bezel shape	TEAC standard		
Front lever shape	TEAC standard		
LED indicator color	Green		
Pop-up mechanism	Not equipped.		
Shield cover	Not equipped.		
Input signal terminator	1k Ω \pm 5%, unremovable		
Customer selectable straps	D0-D3, U0, U1, IU, RY/DC, LG, E2, I		
Strap setting at delivery	D1, DC		
Other optional function	Not equipped.		

PHYSICAL SPECIFICATION

- (1) Width: 146mm (5.75 in), Nom.
- (2) Height: 41.3mm (1.63 in), Nom.
- (3) Depth: 203mm (7.99 in), Nom.
(excludes projections of interface connectors)
- (4) Weight: 1.00kg (2.20 lbs), Nom., 1.10kg (2.43 lbs), Max.
- (5) External view: See Fig.1.
- (6) Cooling: Natural air cooling
- (7) Mounting: Mounting for the following directions are acceptable.
 - (a) Front loading, mounted vertically.
 - (b) Front loading, mounted horizontally with spindle motor down.
 - (c) Mounting angle in items (a) and (b) should be less than 15° with front bezel up.Note: As to the other mounting directions than the above will be considered separately.
- (8) Installation: With installation holes on the frame of the FDD.
Refer to Fig.1.
- (9) Material of frame: Aluminum diecast
- (10) Material of front bezel: PPHOX (Xyron)

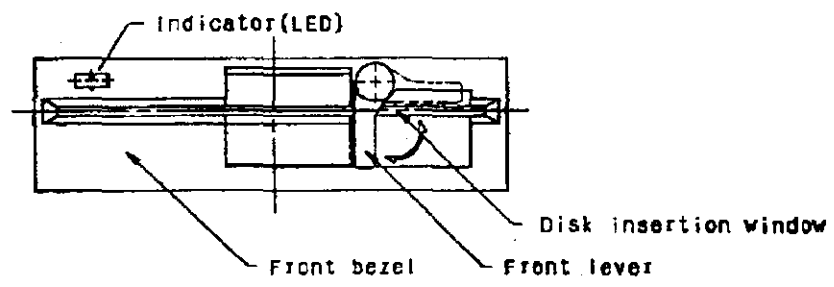
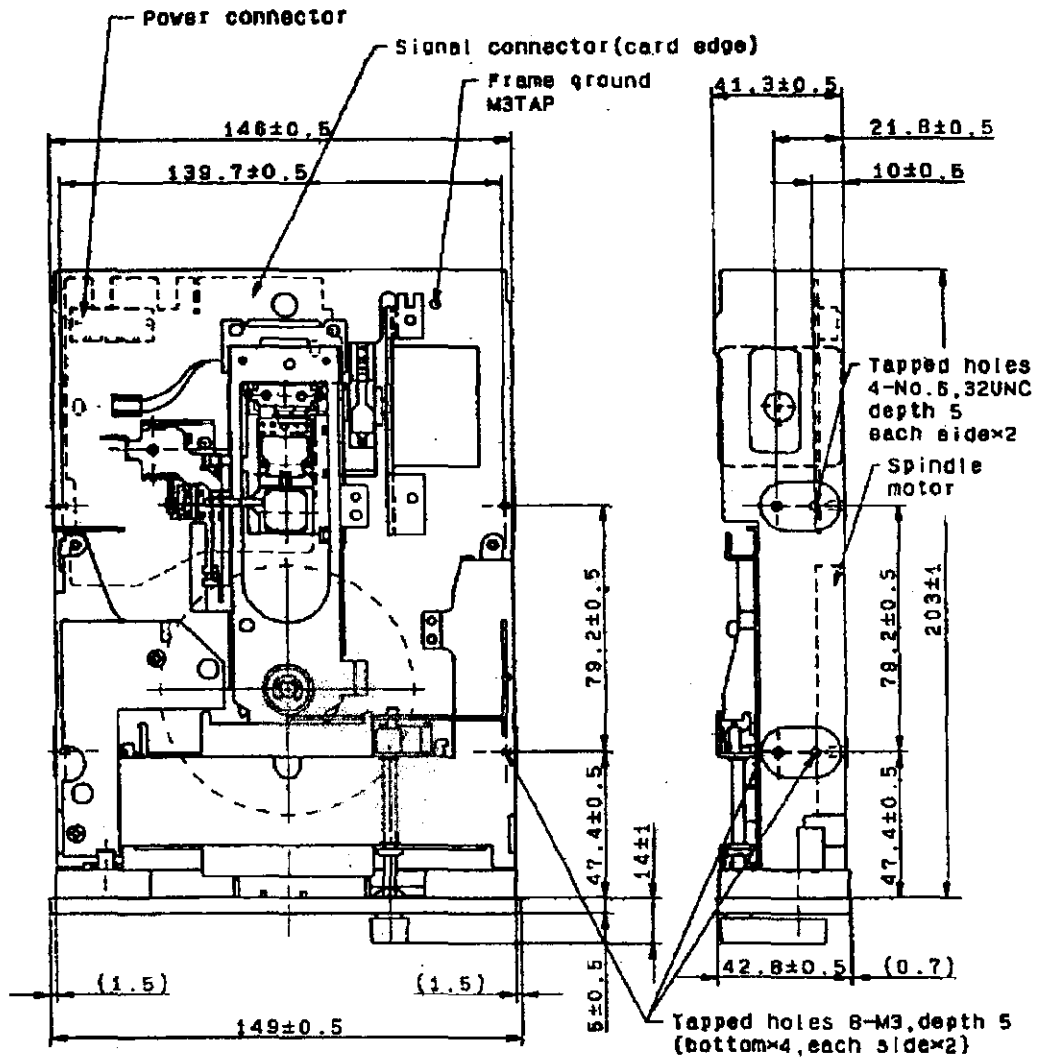

(Units: mm)

ENVIRONMENTAL CONDITIONS

Note: The following requirements are applied for the unpackaged FDD.

(1) Ambient temperature

- (a) Operating : 4 - 46°C (39 - 115°F)
- (b) Storage : -22 - 60°C (-8 - 140°F)
- (c) Transportation: -40 - 65°C (-40 - 149°F)

(2) Temperature gradient

- (a) Operating : 15°C (27°F) or less per hour
- (b) Storage and transportation
: 30°C (54°F) or less per hour

(3) Relative humidity

- (a) Operating : 20 - 80% (no condensation)
Max. wet bulb temperature shall be 29°C (84°F)
- (b) Storage : 10 - 90% (no condensation)
Max. wet bulb temperature shall be 40°C (104°F)
- (c) Transportation: 5 - 95% (no condensation)
Max. wet bulb temperature shall be 45°C (113°F)

(4) Vibration

- (a) Operating : 0.5G or less (55Hz or less)
0.25G or less (55 - 500Hz)
- (b) Transportation: 2G or less (100Hz or less)

(5) Shock

- (a) Operating : 5G (11msec) or less
- (b) Transportation: 50G (11msec) or less

(6) Altitude

- (a) Operating: Less than 5,000m (16,500 feet)
- (b) Transportation: Less than 12,000m (40,000 feet)

Note: The above requirements are applied for the FDD without shipping box.
When a long period is required for transportation such as by ship, the
storage environmental condition shall be applied.

RELIABILITY

- (1) MTBF: 20,000 power on hours or more (for typical operation duty)
- (2) MTTR: Less than 30 minutes
- (3) Design component life: 5 years
- (4) Disk life: 3×10^6 passes/track or more
- (5) Disk insertion: 3×10^4 times or more
- (6) Preventive maintenance: Not required (for typical operation duty)
- (7) Error rate
 - (a) Soft error: 1 per 10^9 bits (up to 2 retries)
 - (b) Hard error: 1 per 10^{12} bits
 - (c) Seek error: 1 per 10^6 seeks
- (8) Safety standard: Complying with UL and CSA

FD55 GPR-7XXX
Strap (jumper) definition.

LG strap:

Strap to select the logical meaning of the Hi/Normal DENSITY input signal level at interface line #2.

LG Strap	OFF		ON	
	HI	LOW	HI	LOW
Density Mode	HI	LOW	HI	LOW
I/F #2 signal level	HI	LOW	LOW	HI

For an AT compatible system LG should be set to the OFF state.

I strap:

Strap to select the rotational speed mode of the FDD for the HI and LOW density modes.

Mode	SINGAL		DUAL	
	HI	LOW	HI	LOW
I Strap	OFF		ON	
Density Mode	HI	LOW	HI	LOW
RPM (Motor speed)	360	360	360	300

For the correct setting of this strap refer to your controller card's documentation.

E2 Strap:

Strap to select the output condition of the INDEX and the READ DATA pulses.

E2 off state:

Index - Index hole detection * DRIVE selected * Ready state * Seek complete.

READ Data - Read data detection * DRIVE selected * Ready state * Not writing * Seek complete.

E2 on state:

Index - Index hole detection * DRIVE selected * Ready state.

READ Data - Read data detected * DRIVE selected * Ready state * Not writing.

**** Note:** Set the E2 strap to the ON state only if your computer requires MASKING THE INDEX. (ie. PC and older PCXT that do not give the drive enough time to reach a ready state when the disk replaced.

FD55 GFR-7XXX
Strap (jumper) definition.

D0 - D3 straps:

Drive Select (address) 0 thru 3.
With a twisted interface cable, both the "A:" and "B:" drives should be set for D1. The "A:" drive should be connected to the twisted end and the "B:" drive to the untwisted connector. On an untwisted cable the position of the drives is not defined, however the "A:" drive should be set at D2 and the "B:" drive set at D1. ** Note: With an untwisted cable you may have to short lines 10 and 16 together to turn the spindle motor on when the drive is selected.

U0 and U1 straps:

Setup one of 5 possible LED (indicator) turn on conditions. It is best to use condition #1 for an AT system.

Cond #	Strap-combination			Indicator turn on conditions
	IU	U0	U1	
1	--	--	--	Drive Select
2	ON	--	--	Drive Select + In Use
3	ON	ON	--	In Use (see IU strap)
4	--	ON	ON	Drive Select * Ready
5	ON	ON	ON	In Use + (Drive Select * Ready)

(+) means OR condition. (*) means AND condition.
(--) means off.

IU strap:

Strap to make the signal interface #4 be used for the IN USE input signal. ON state
The signal interface line #4 is open when the strap is off state.

RY & DC straps:

Straps to select the output signal at interface line #34.
RY on state outputs the READY signal.
DC on state outputs the DISK CHANGE signal.
The disk change signal is the required signal for line #34 when connected to an AT compatible system.

**FD55 GFR-7XXX series FDD
Strap (jumper) definition**

- › **Strap (jumper) location on the printed circuit board.**

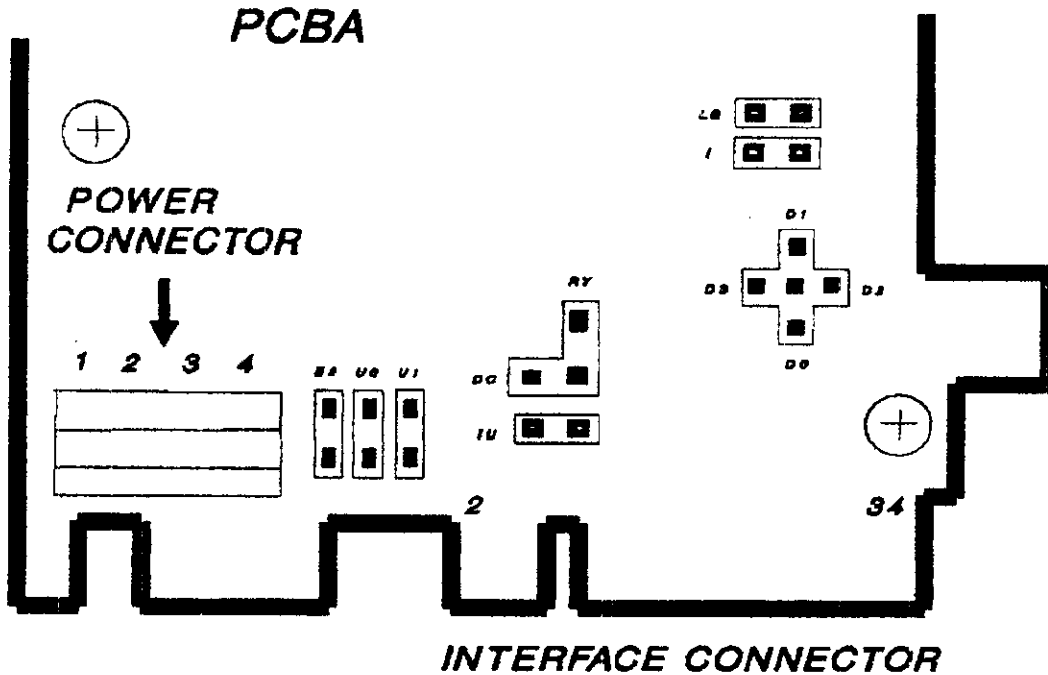

- › **The factory strap (jumper) settings are:**

D1 - Drive Select #1

DC - Disk change signal output at line #34

**This configuration will enable the drive to work
as either an "A:" drive or a "B:" drive.**

If the INTERFACE cable has a twist at the end.

- › **Power connector:** #1 - 12 vdc
#2 & #3 - 0vdc, ground
#4 - 5 vdc

TEAC FD-55 Series 5¼" 1.2 MB Floppy Disk Drive Installation Guide

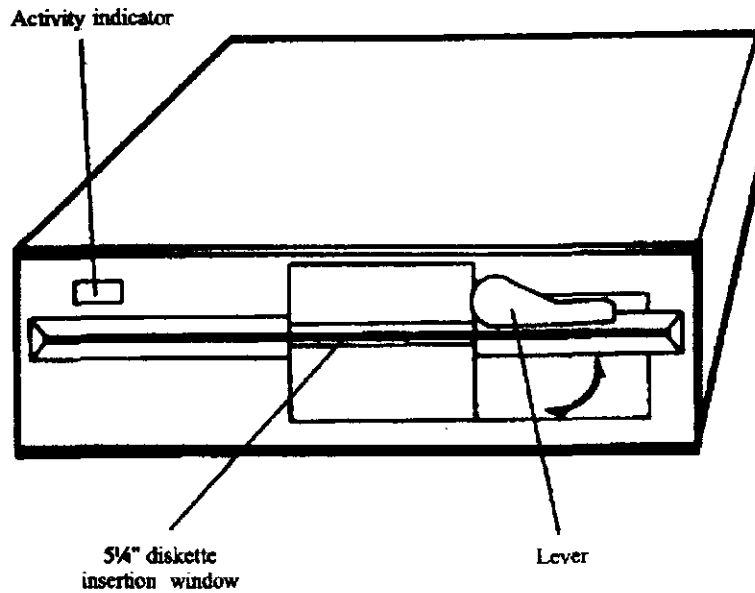

Your FD-55 package includes:

- FD-55 floppy disk drive
- Installation guide

Introduction

Thank you for purchasing the TEAC FD-55 Series 1.2 MB floppy disk drive. This product is intended for use in IBM@ PC/XT/AT@ and compatible computers.

This quality drive will provide trouble-free operation for your computer system if properly installed. PLEASE READ THE ENTIRE INSTALLATION GUIDE THOROUGHLY BEFORE YOU BEGIN THE INSTALLATION. If you have questions or comments on the installation, please call TEAC Technical Support Center at the telephone number listed on the back page of this Guide.

Tools You May Need

Depending on the design of your computer, you may need the following tools to complete the installation.

- a flat blade screwdriver
- a Phillips screwdriver
- needle-nosed pliers



Handling the FD-55 Series 5¼" Drive

Your FD-55 series drive must be handled with care. Avoid applying undue force or abnormal strain to the spindle motor, stepping motor or printed circuit board. Avoid placing your fingers on the **printed circuit board**. It is best to hold the FD-55 by the **diecast frame**, as indicated by the arrows in figure A.

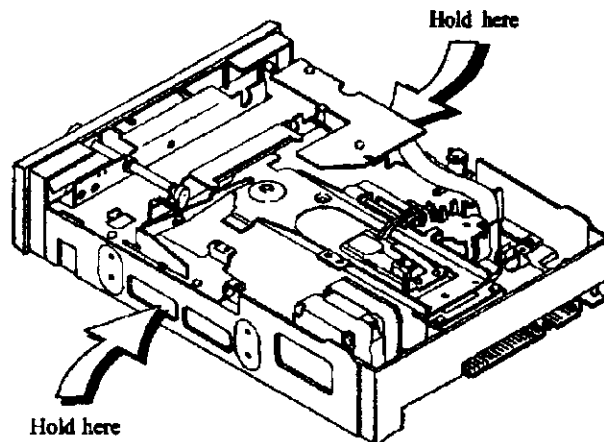

Figure A

Preparing your Personal Computer for FD-55 Floppy Drive Installation

CAUTION: TURN OFF YOUR COMPUTER AND UNPLUG IT FROM THE AC POWER SOURCE BEFORE INSTALLING THE FD-55. FAILURE TO DO SO MAY RESULT IN ELECTRIC SHOCK.

1. Unplug your computer.
2. Detach all input and output devices from your computer, such as printer, keyboard, monitor, etc.
3. Remove cover from your computer. Refer to your computer system manual for this procedure.
4. If you are replacing a current floppy, note the cables that are connected to your floppy disk drive, as these same cables will be required to install your FD-55. The floppy interface cable is the flat "ribbon" type, and the power connector consists of the 4 separate wires attached to a single connector. See figure B.
5. Your system may also have a single ground wire attached to the floppy disk drive. Carefully remove all cables from your floppy disk drive.
6. Install the FD-55 floppy disk drive into an available drive bay.

Rear View of FD-55

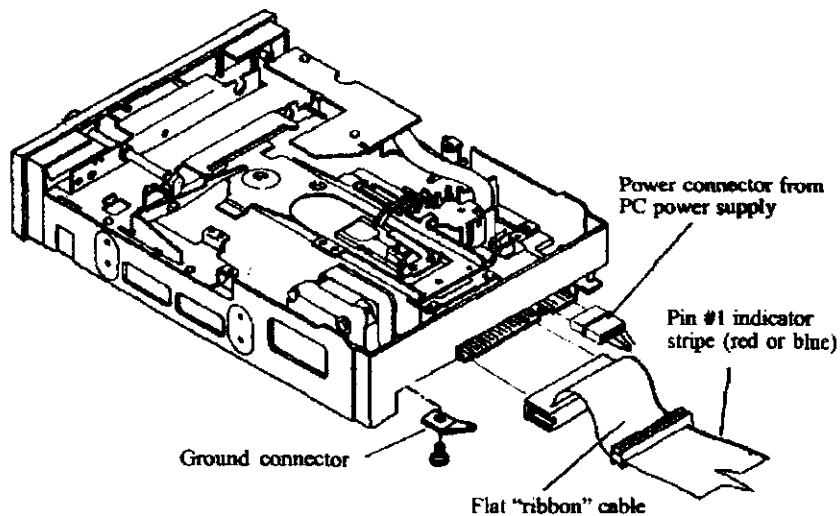

Figure B

Configuring for A: or B: drive

Using an standard IBM PC compatible cable with a twist at the end connector (figure C) and the **factory default strap settings** (shown in figure D).

- a) To configure as your A: drive connect the FD-55 floppy drive to **Connector A:** on the flat "ribbon" cable. **Connector A:** is the end connector of the cable as shown in the sketch.
- b) To configure as your B: drive connect the FD-55 floppy drive to **Connector B:** on the flat "ribbon" cable. **Connector B:** is the middle connector of the cable as shown in the sketch.
- c) Verify jumpers are set as indicated in figure D.
- d) Connect the ground cable if your system requires it.

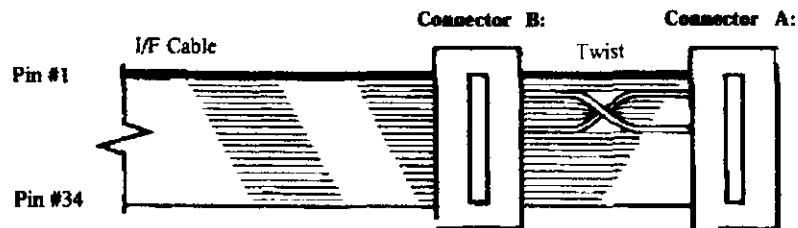

Figure C

Note: Be sure to make the correct changes to the CMOS BIOS setup after you install you FD-55.

FD-55 Jumper Matrix

Factory defaults are shaded.

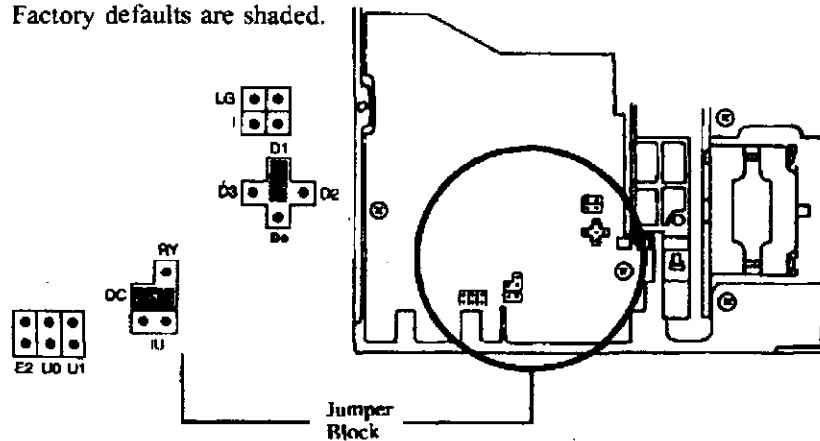

Figure D

Notes on Installing Your FD-55

Slide drive into any available bay.

Locate your system's floppy drive ribbon cable. The cable may be keyed to assist with alignment. If yours is not keyed, it should be attached so that the color strip (red or blue) faces the power connector located on the rear of the FD-55 drive. This is Pin 1.

1. Re-attach power connector.
2. Replace the cover.
3. Re-attach all input and output devices.
4. Plug in computer.

Attaching Mounting Rails, if required

Your system may or may not require mounting rails to install the FD-55 floppy drive.

If rails are required, use rails from disk drive that is being replaced, or contact your local distributor and/or TEAC parts department (ext. 840) for mounting rails.

The tapered end of each rail, when mounted, should point toward the back of the FD-55 floppy drive as shown in figure E.

Note: Each rail is marked on the inside surface with "R" indicating the right rail, or "L" for the left rail.

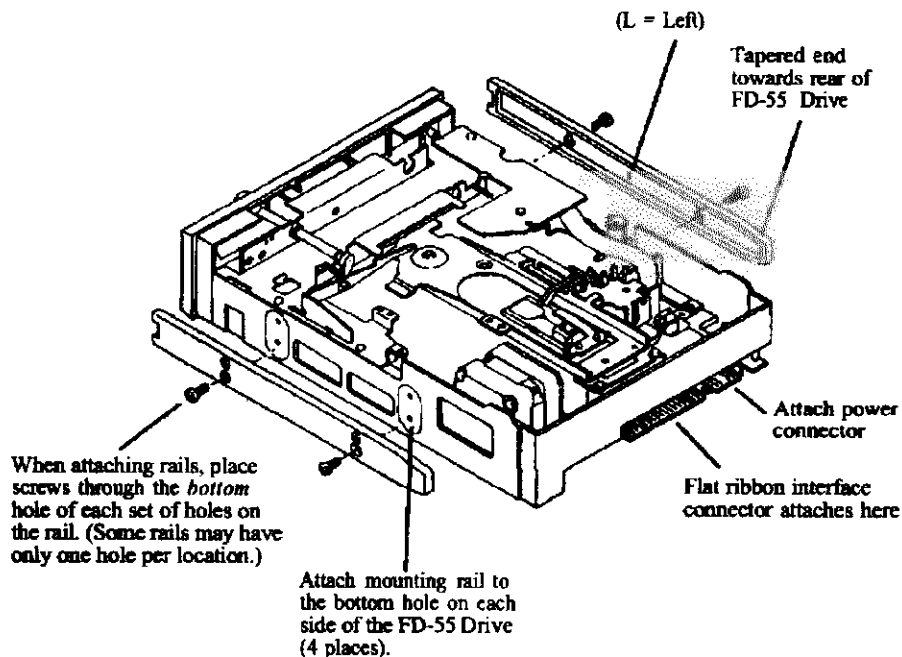

Figure E

Trouble Shooting

Symptom	Solution
Indicator light never turns on when executing READ or WRITE.	Make sure that the interface cable and power cable are properly connected and drive address strap is set correctly.
Indicator light comes on as soon as power is applied and stays on.	The ribbon cable may be reversed. Check pin #1 orientation.
Drive type mismatch during boot.	Check CMOS setup for correct drive type. If the indicator comes on, check for head recalibration to Track 00; if it doesn't, drive may be malfunctioning.
Invalid media or Track 00 bad when formatting.	Attempted to format an HD diskette to 360K or DD diskette to 1.2 MB. Drive is not properly set in CMOS setup. Or controller card is not configured correctly. Check setup by referring to controller documentation.
The same directory is displayed for different diskettes.	Controller card is not receiving disk change signal. Check the drive for the correct disk change strap setting. Pin #34 on the ribbon cable is broken. Or disk drive is malfunctioning.
Drive not ready error reading drive X.	No diskette inserted in the drive or motor not spinning. Drive may need service.
General failure error reading drive X.	Diskette not formatted. Drive out of alignment. LD or ND disk formatted to 1.2 MB. HD disk formatted for 360K. Use correct disk.
Sector not found error.	Head seek error or drive out of alignment.

TEAC Tech Support: To have installation guides, specification sheets, and other product information faxed to you, 7 days a week, 24 hrs. a day, call our Fax on Demand Line at 323-727-7629.

TEAC America, Inc., 7733 Telegraph Rd., Montebello, CA 90640
323-726-0303 ext 860

*IBM PC/XT/AT are registered trademarks of International Business Machines Corp.

4/01/98