

**SA455/465
Minifloppy™
Drive**

P/N 39239-0

**Service Manual
May 1983**

Shugart

TABLE OF CONTENTS

	Page
TABLE OF CONTENTS	i
LIST OF FIGURES	iii
LIST OF TABLES	iv
ABBREVIATIONS/MNEMONICS	v
SECTION I INTRODUCTION	1-1
1.1 General Description	1-1
1.2 Specification Summary	1-1
1.2.1 Performance Specifications	1-1
1.2.2 Functional Specifications	1-2
1.2.3 Physical Specifications	1-2
1.2.4 Reliability Specifications	1-3
1.3 Functional Characteristics	1-3
1.3.1 Read/Write and Control Electronics	1-3
1.3.2 Drive Mechanism	1-3
1.3.3 Positioning Mechanics	1-3
1.3.4 Read/Write Heads	1-3
1.3.5 Recording Formats	1-4
1.4 Functional Operations	1-5
1.4.1 Power Sequencing	1-5
1.4.2 Drive Selection	1-5
1.4.3 Motor On	1-5
1.4.4 Track Accessing	1-5
1.4.5 Step Out	1-5
1.4.6 Step In	1-5
1.4.7 Side Selection	1-5
1.4.8 Read Operation	1-7
1.4.9 Write Operation	1-8
1.4.10 Sequence of Events	1-8
SECTION II ELECTRICAL INTERFACE	2-1
2.1 Introduction	2-1
2.2 Signal Interface	2-2
2.2.1 Input Lines	2-2
2.2.2 Input Line Terminations	2-3
2.2.3 Drive Select 1—4	2-3
2.2.4 Motor On	2-3
2.2.5 Direction Select	2-3
2.2.6 Step	2-3
2.2.7 Write Gate	2-3
2.2.8 Write Data	2-4
2.2.9 Side Select	2-4
2.2.10 Output Lines	2-4
2.2.11 Track 00	2-5
2.2.12 Index/Sector	2-5
2.2.13 Read Data	2-5
2.2.14 Write Protect	2-6
2.2.15 Ready	2-6
2.3 Power Interface	2-6
2.4 Frame Ground	2-6
SECTION III PHYSICAL INTERFACE	3-1
3.1 Introduction	3-1
3.1.1 J1/P1 Connector	3-1
3.1.2 J2/P2 Connector	3-1
3.2 Frame Grounding	3-2

TABLE OF CONTENTS (CONT.)

SECTION IV	THEORY OF OPERATION	4-1
	4.1 Theory of Operation	4-1
	4.2 Read/Write Operations	4-1
	4.3 Read/Write Head	4-3
	4.4 Write Circuit Operation	4-4
	4.5 Read Circuit Operation	4-5
	4.6 Drive Motor Control	4-5
	4.7 Index Detector	4-6
	4.8 Track Zero Indication	4-6
	4.9 Track Accessing	4-6
	4.9.1 Stepper Motor	4-6
	4.9.2 Stepper Control	4-6
	4.10 Drive Select	4-7
	4.11 Write Protect	4-8
	4.12 Ready	4-6
SECTION V	MAINTENANCE	5-1
	5.1 Maintenance Equipment	5-1
	5.1.1 Alignment Diskette	5-1
	5.1.2 Exerciser PCB	5-1
	5.1.3 Special Tools	5-2
	5.2 Diagnostic Techniques	5-2
	5.2.1 Introduction	5-2
	5.2.2 "Soft Error" Detection and Correction	5-2
	5.2.3 Write Error	5-2
	5.2.4 Read Error	5-3
	5.2.5 Seek Error	5-3
	5.3 Trouble-Shooting	5-3
	5.4 Adjustments	5-8
	5.4.1 Head Radial Alignment	5-8
	5.4.2 Read/Write Head(s) Azimuth Check	5-9
	5.4.3 Head Amplitude Check	5-10
	5.4.4 Track Zero Detector Assembly Adjustment	5-11
	5.4.5 Index/Sector Timing Adjustment	5-12
	5.4.6 Motor Speed Adjustment (Using a Frequency Counter)	5-13
	5.4.7 Write Protect Detector	5-13
	5.4.8 Test Points On Drive PCB	5-13
	5.5 Removals and Replacements	5-15
	5.5.1 Faceplate Latch	5-15
	5.5.2 Direct Drive Motor Assembly	5-15
	5.5.3 Head and Carriage Assembly	5-15
	5.5.4 Stepper Motor and Actuator Assembly	5-15
	5.5.5 Clamp Hub	5-15
	5.5.6 Write Protect Sensor and Index Detector	5-15
	5.5.7 Track Zero Photo Detector	5-16
	5.6 Recommended Incoming Receiving Inspection	5-16
	5.6.1 Necessary Equipment	5-16
	5.6.2 Procedure	5-16
SECTION VI	SCHEMATIC DIAGRAMS	6-1
SECTION VII	ILLUSTRATED PARTS CATALOG	7-1
	7.1 Description	7-1
	7.2 Quantity Per Assembly	7-1
	7.3 Recommended Spare Parts Stocking Guide	7-11

LIST OF FIGURES

Figure		Page
1-1	SA455/465 Double Sided Minifloppy™ Drive	1-0
1-2	SA455/465 Functional Diagram	1-4
1-3	Step To Read	1-6
1-4	Write To Step	1-6
1-5	Read To Write (FM)	1-7
1-6	Read Data Timing (FM)	1-7
1-7	FM and MFM Code Comparisons	1-8
1-8	Write Data Timing (FM)	1-9
1-9	Power On To Step	1-9
2-1	Interface Connections	2-1
2-2	Interface Signal Driver/Receiver	2-2
2-3	Step Timing	2-4
2-4	Write Data Timing	2-4
2-5	Index Timing (SA154/164 Media)	2-5
2-6	Index/Sector Timing (SA155/165 Media)	2-5
2-7	Index/Sector Timing (SA157/167 Media)	2-5
3-1	Interface Connectors Physical Locations	3-1
3-2	J1 Connector Dimensions	3-2
3-3	J2 Connector	3-2
4-1	Byte	4-1
4-2	Basic Read/Write Head	4-2
4-3	Recorded Bit	4-2
4-4	Reading A Bit	4-2
4-5	1F and 2F Recording Flux and Pulse Relationship	4-3
4-6	Read/Write Heads	4-3
4-7	Write Circuit	4-4
4-8	Read Circuit	4-5
4-9	Index Detector	4-6
4-10	Stepper Timing	4-7
4-11	Power On Reset	4-7
4-12	Drive Select	4-7
4-13	Write Protect	4-8
5-1	Write Protect Inoperative	5-3
5-2	Diskette Not Rotating	5-4
5-3	Track 00 Indicator Inoperative	5-5
5-4	Drive Not Coming On Line	5-6
5-5	Index Pulse Inoperative	5-7
5-6	Alignment Lobes	5-8
5-7	Stepper Motor Mounting Screws	5-9
5-8	Azimuth Check	5-10
5-9	Track Zero Adjustment	5-11
5-10	Index Burst	5-12
5-11	Index Detector	5-13
5-12	PCB Component Locations, P/N's 25284 and 25286	5-14
6-1	Schematic Diagram, P/N 25284	6-3
6-2	Schematic Diagram, P/N 25286	6-5
7-1	SA455/465 Basic Drive Assembly (4 Sheets)	7-2

LIST OF TABLES

Table		Page
2-1	DC Power Requirements	2-6
7-1	Figure Reference To Part Number Cross Reference	7-10
7-2	SA455/465 Spare Parts Stocking Guide	7-11

ABBREVIATIONS/MNEMONICS

AM	Address Mark	NRZ	Non Return to Zero
bpi	Bits Per Inch	PCB	Printed Circuit Board
CRC	Cyclic Redundancy Check	PM	Preventive Maintenance
fci	Flux Changes Per Inch	POH	Power On Hours
FM	Frequency Modulation	PSI	Product Selection Index
GND	Ground	TP	Test Point
ID	Index	tpi	Tracks Per Inch
I/O	Input/Output	TRK	Track
MFM	Modified FM	WG OFF	Write Gate Off
MTBF	Mean Time Between Failures	1F	Single Density
MTTR	Mean Time to Repair	2F	Double Density

ABOUT THIS MANUAL

While every effort has been made to ensure that the information provided herein is correct, please notify us in the event of an error or inconsistency. Direct any comments on the form at the back of this manual to:

Shugart
Technical Publications, MS 3-14
475 Oakmead Parkway
Sunnyvale, CA 94086
(408) 733-0100

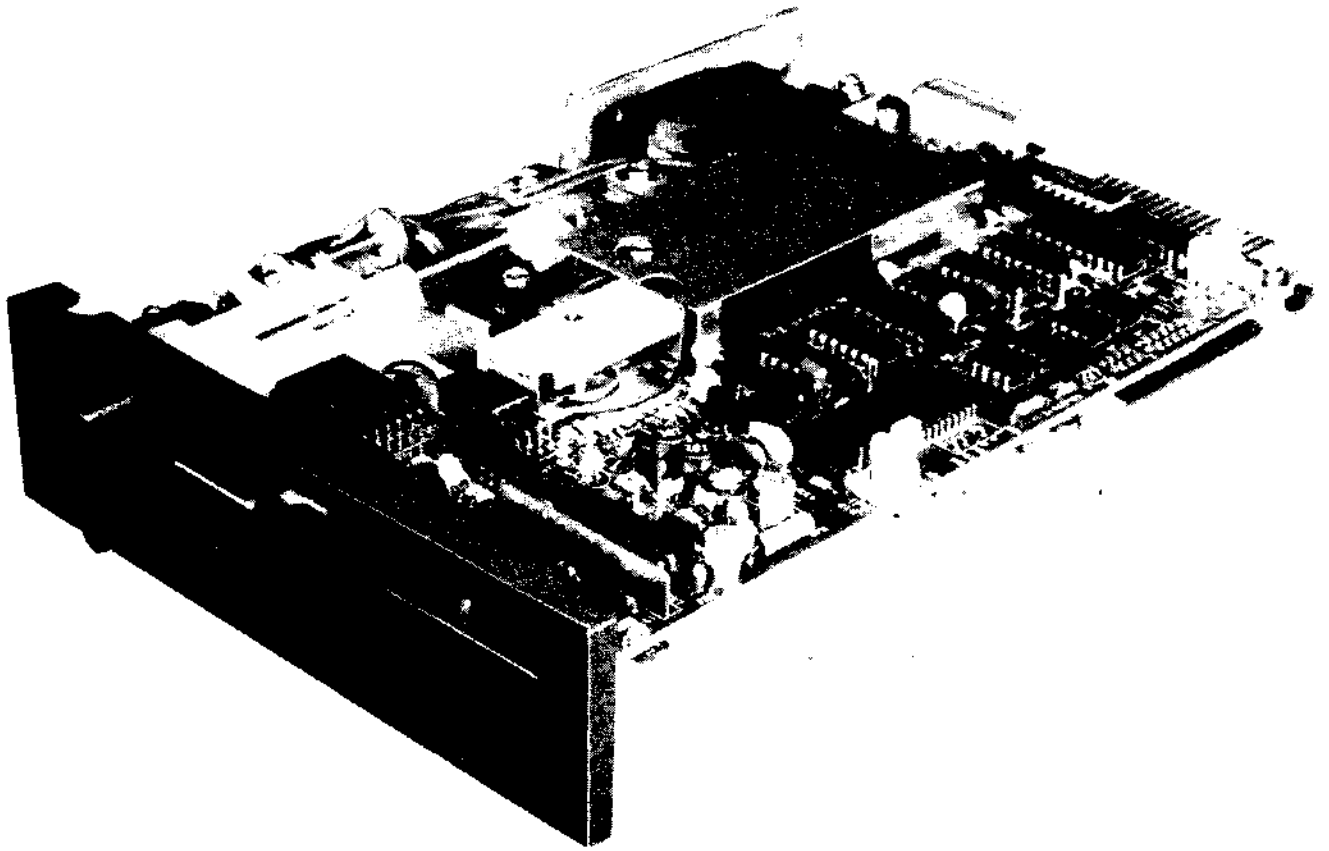

39238-01-A

FIGURE 1-1. SA455/465 DOUBLE-SIDED MINIFLOPPY™ DRIVE

SECTION I INTRODUCTION

1.1 GENERAL DESCRIPTION

The SA455/465 Minifloppy Disk Drives are enhanced double-headed, half-height versions of the Shugart SA400 minifloppy drives. The SA455/465 provides up to four times the on-line storage capacity, faster access time, and improved reliability and maintainability.

SA455/465 drives read and write in single and double density on standard 5.25 inch diskettes on both sides of the diskettes. The new drives are half the height of the Shugart SA400 and are plug compatible.

The compact SA455/465 offers a reliable, low cost, high performance alternative to OEM data storage applications where tape cassette units would have been previously considered.

SA455/465 drives have these standard features: compact size - 1.62 inches high × 5.75 inches wide × 7.96 inches deep, and a weight of 3.3 pounds; low heat dissipation; dc drive motor with precision servo speed control and integral tachometer; band positioner; same proprietary glass bonded ferrite/ceramic read/write head as used in Shugart's large floppy drives; internal write protect circuitry; activity light, and solid die cast chassis.

Typical applications for the SA455/465 are word processing systems, entry level micro-processor systems, intelligent calculators, program storage, hobby computer systems, and other applications where low cost random access data storage is a requirement.

This manual provides depot level maintenance information necessary to maintain, trouble-shoot, and repair the SA455/465. A separate OEM manual (P/N 39238) is available which describes installation, interface, and power requirements useful for the applications of the drive.

Key Features

- a. 0.5 Mbytes (SA455) or 1.0 Mbyte (SA465) storage capacity (unformatted)
- b. Low power (12.5 watts)
- c. 125/250 kbits/second transfer rate
- d. DC drive motor (eliminates ac requirements)

1.2 SPECIFICATION SUMMARY

1.2.1 Performance Specifications

Capacity (in bytes)	SA455 (40 Track)		SA465 (80 Track)	
	Single Density (FM)	Double Density (MFM)	Single Density (FM)	Double Density (MFM)
Unformatted				
Per Disk	250,000	500,000	500,000	1,000,000
Per Surface	125,000	250,000	250,000	500,000
Per Track	3,125	6,250	3,125	6,250

	SA455 (40 Track)		SA465 (80 Track)	
	Single Density	Double Density	Single Density	Double Density
Formatted (16 Records/Track)				
Per Disk	163,840	327,680	327,680	655,360
Per Track	2,048	4,096	2,048	4,096
Per Sector	128	256	128	256
Formatted (10 Records/Track)				
Per Disk	204,800	409,600	409,600	819,200
Per Track	2560	5120	2560	5120
Per Sector	256	512	256	512
Transfer Rate	125 kbits/sec	250 kbits/sec	125 kbits/sec	250 kbits/sec
Latency (avg.)	100 ms	100 ms	100 ms	100 ms
Access Time				
Track to Track	6 ms	6 ms	3 ms	3 ms
Average	93 ms	93 ms	94 ms	94 ms
Settling Time	15 ms	15 ms	15 ms	15 ms

1.2.2 Functional Specifications

Motor Start Time	500 ms	500 ms	500 ms	500 ms
Rotational Speed	300 rpm	300 rpm	300 rpm	300 rpm
Recording Density	2938 bpi	5876 bpi	2961 bpi	5922 bpi
Flux Density	5876 fci	5876 fci	5922 fci	5922 fci
Track Density	48 tpi	48 tpi	96 tpi	96 tpi
Media Requirements				
Soft sectored	SA154	SA154	SA164	SA164
16 sectors hard sectored	SA155	SA155	SA165	SA165
10 sectors hard sectored	SA157	SA157	SA167	SA167
Industry standard flexible diskette				
Oxide on 0.003 in. (0.08 mm) Mylar				
5.25 in. (133.4 mm) square jacket				

1.2.3 Physical Specifications

Environmental Limits	Operating	Shipping	Storage
Ambient Temperature	50° to 115°F (10.0° to 46.1°C)	-40° to 144°F (-40° to 62.2°C)	-8° to 117°F (-22.2° to 47.2°C)
Relative Humidity	20 to 80%	1 to 95%	1 to 95%
Maximum Wet Bulb	78°F (25.6°C)	No Condensation	No Condensation
Shock	0.5G 10 ms	15G 10 ms	35G 10 ms
Vibration	0.5G 5-600 Hz	3G 5-600 Hz	3G 5-600 Hz

DC Voltage Requirements
+12 V ± 10% @ 1.2 A (max), 0.6 A (typ), 100 mV ripple
+ 5 V ± 5% @ 0.9 A (max), 0.6 A (typ), 50 mV ripple

Mechanical Dimensions (exclusive of front panel)
Width = 5.75 inches (146.1 mm)
Height = 1.62 inches (41.1 mm)
Depth = 7.96 inches (202 mm)
Weight = 3.3 lbs (1.5 kg)
Power Dissipation = 9.6 Watts (34.0 BTU) continuous typical
3.6 Watts (13.5 BTU) standby

NOTE

Standby: Drive motor off, drive select off, and stepper at reduced current.

1.2.4 Reliability Specifications

MTBF: 10,000 POH under typical usage.
PM: Not required.
MTTR: 30 minutes.

Error Rates:

Soft Read Errors: 1 per 10^9 bits read.
Hard Read Errors: 1 per 10^{12} bits read.
Seek Errors: 1 per 10^6 seeks.

Media Life:

Passes per Track: 3.0×10^6
Insertions: 30,000 +

1.3 FUNCTIONAL CHARACTERISTICS

The SA455/465 consists of read/write and control electronics, drive mechanism, read/write head, and precision track positioning mechanism. These components perform the following functions:

- a. Interpret and generate control signals.
- b. Move read/write heads to the desired track.
- c. Read and write data.

The interface signals and their relationship to the internal functions are shown in figure 1-2.

1.3.1 Read/Write and Control Electronics

The electronics package contains:

- a. Index detector circuits
- b. Head position actuator driver
- c. Read/write amplifier and transition detector
- d. Write protect detector
- e. Drive select circuit
- f. Drive motor control

1.3.2 Drive Mechanism

The dc drive motor under servo speed control (using an integral tachometer) rotates the spindle at 300 rpm through a direct drive system. An expandable collet/spindle assembly provides precision media positioning to ensure data interchange.

1.3.3 Positioning Mechanics

The read/write head assembly is accurately positioned through the use of a band positioner which is attached to the head carriage assembly. Precise track location is accomplished as this positioner is rotated in discrete increments by a stepping motor.

1.3.4 Read/Write Heads

The proprietary heads are a single element ceramic read/write head with tunnel erase elements to provide erased areas between data tracks. Thus normal interchange tolerances between media and drives will not degrade the signal-to-noise ratio and diskette interchangeability is ensured.

The read/write heads are mounted on a carriage which is located on precision carriage ways. The diskette is held in a plane perpendicular to the read/write heads by a platen located on the base casting. This precise registration assures perfect compliance with the read/write heads. The read/write heads are in direct contact with the diskette. The head surface has been designed to obtain maximum signal transfer to and from the magnetic surface of the diskette with minimum head/diskette wear.

1.3.5 Recording Formats

The formats of the data recorded on the diskette are totally a function of the host system. These formats can be designed around the user's application to take maximum advantage of the total available bits that can be written on any one track.

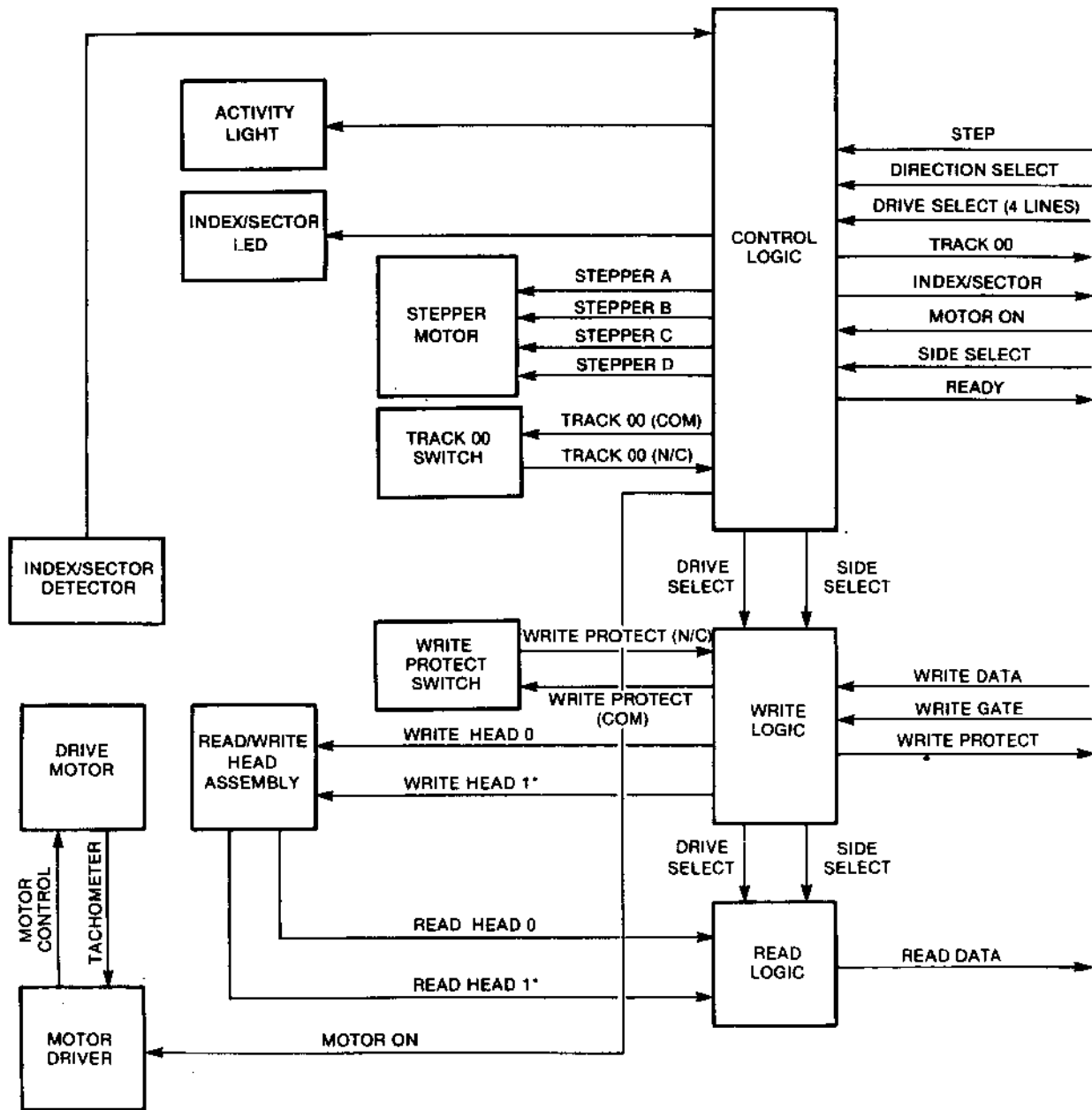

*SA465 ONLY.

39238-02-A

FIGURE 1-2. SA455/465 FUNCTIONAL DIAGRAM

1.4 FUNCTIONAL OPERATIONS

1.4.1 Power Sequencing

Applying dc power to the SA455/465 can be done in any sequence. However, during power up, the WRITE GATE line must be held inactive or at a high level. This will prevent possible "glitching" of the media. After application of dc power, a 100 ms delay should be introduced before any operation is performed. After powering on, initial position of the read/write heads with respect to the data tracks on the media is indeterminant. In order to assure proper positioning of the read/write heads after power on, a Step Out operation should be performed until the TRACK 00 line becomes active (Recalibrate).

1.4.2 Drive Selection

Drive selection occurs when the proper DRIVE SELECT line is activated. Only the drive with this line jumpered will respond to input lines or gate output lines.

1.4.3 Motor On

In order for the host system to read or write data, the dc drive motor must be turned on. This is accomplished by activating the line -MOTOR ON. A 500 ms delay must be introduced after activating this line to allow the motor to come up to speed before reading or writing can be accomplished.

The motor must be turned off by the host system by deactivating the MOTOR ON line. The control electronics keep the motor active for 3 seconds, after MOTOR ON is deactivated. This allows reselecting during copy operations and will ensure maximum motor and media life.

1.4.4 Track Accessing

Seeking the read/write heads from one track to another is accomplished by:

- a. Activating the DRIVE SELECT line.
- b. Selecting desired direction using the DIRECTION SELECT line.
- c. WRITE GATE being inactive.
- d. Pulsing the STEP line.

Multiple track accessing is accomplished by repeated pulsing of the STEP line (with direction valid) until the desired track has been reached. Each pulse on the STEP line will cause the read/write heads to move one track either in or out depending on the DIRECTION SELECT line. Head movement is initiated on the trailing edge of the step pulse.

1.4.5 Step Out

With the DIRECTION SELECT line at a plus logic level (2.4 to 5.25 V), a pulse on the STEP line will cause the read/write heads to move one track away from the center of the disk. The pulse(s) applied to the STEP line must have the timing characteristics shown in figures 1-3 and 1-4.

1.4.6 Step In

With the DIRECTION SELECT line at minus logic level (0 to 0.4 V), a pulse on the STEP line will cause the read/write heads to move one track closer to the center of the disk. The pulse(s) applied to the STEP line must have the timing characteristics shown in figures 1-3 and 1-4.

1.4.7 Side Selection

Head selection is controlled via the I/O signal line designated SIDE SELECT. A plus logic level on the SIDE SELECT line selects the read/write head on the side 0 surface of the diskette. A minus logic level selects the side 1 read/write head. When switching from one side to the other, a 100 μ s delay is required after SIDE SELECT changes state before a read or write operation can be initiated. Figure 1-5 shows the use of SIDE SELECT prior to a read operation.

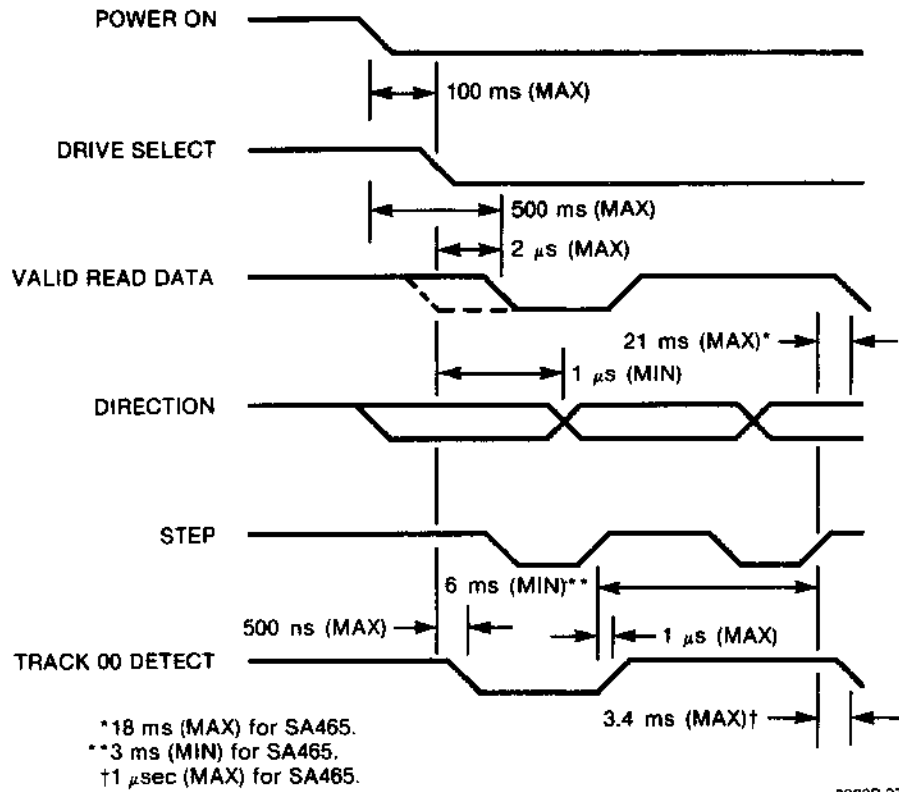

39239-27

FIGURE 1-3. STEP TO READ

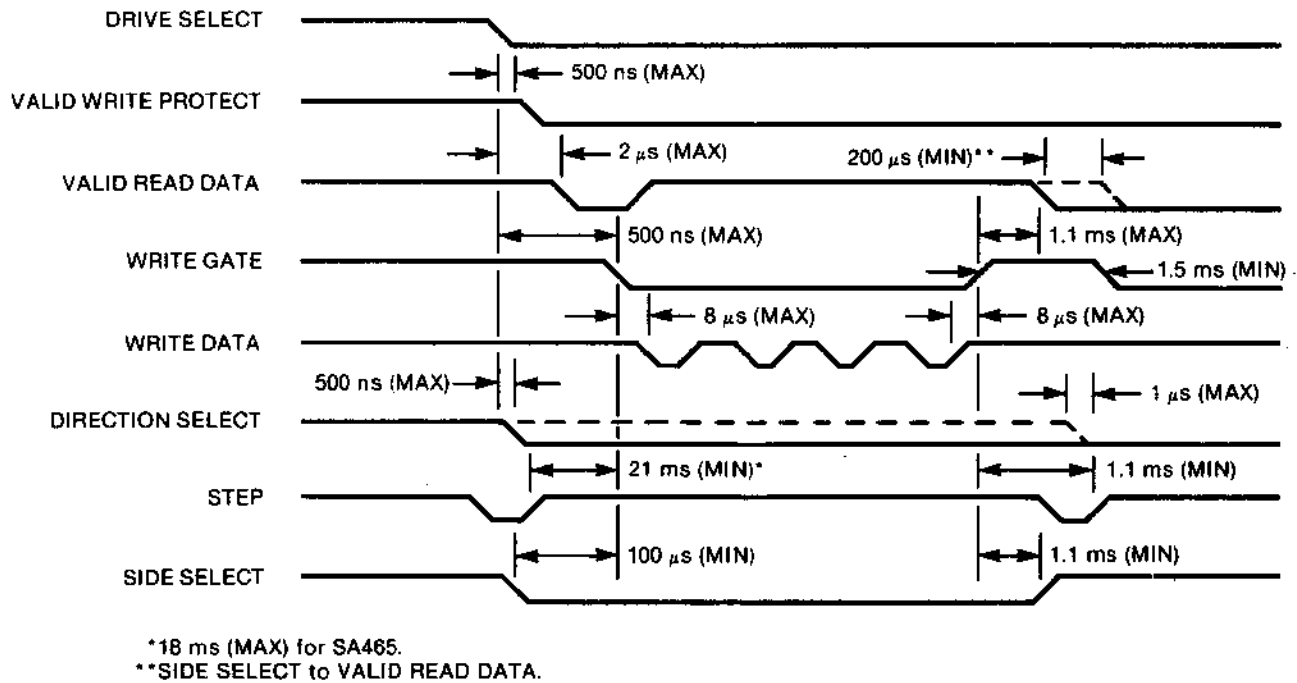

39239-28

FIGURE 1-4. WRITE TO STEP

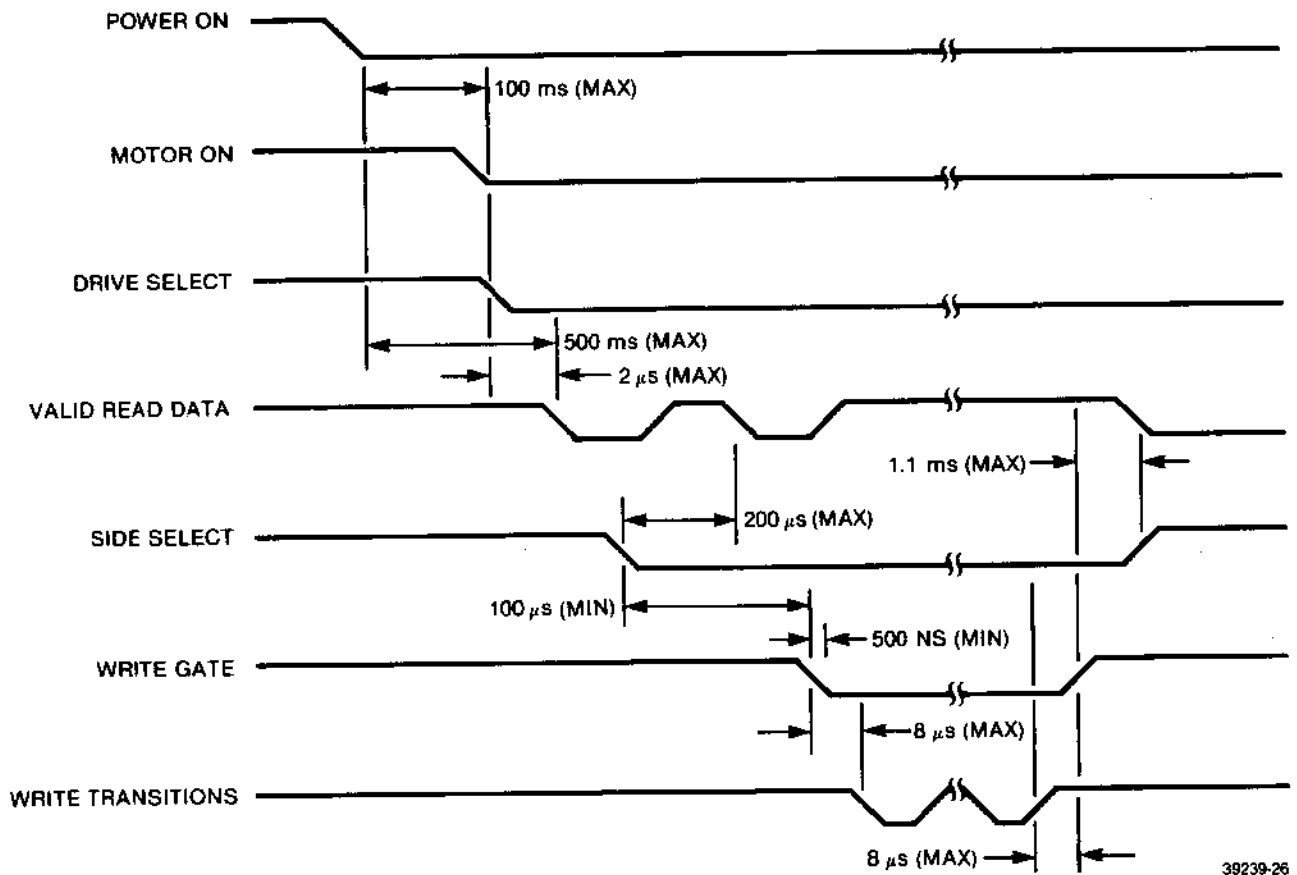

FIGURE 1-5. READ TO WRITE (FM)

1.4.8 Read Operation

Reading data from the SA455/465 is accomplished by:

- Activating the DRIVE SELECT line.
- Selecting the head.
- WRITE GATE being inactive.

The timing relationships required to initiate a read sequence are shown in figure 1-5. These timing specifications are required in order to guarantee that the position of the read/write heads has stabilized prior to reading.

The timing of Read Data (FM) is shown in figure 1-6.

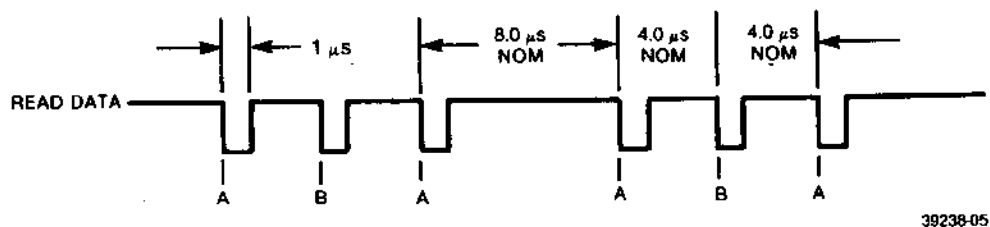

A = LEADING EDGE OF BIT MAY BE ± 800 ns FROM ITS NOMINAL POSITION
 B = LEADING EDGE OF BIT MAY BE ± 400 ns FROM ITS NOMINAL POSITION

FIGURE 1-6. READ DATA TIMNG (FM)

The encoding scheme of the recorded data can be either FM or MFM. FM encoding rules specify a clock bit at the start of every bit cell and a data bit at the center of the bit cell if this cell contains a one data bit, (see figure 1-7). MFM encoding rules allow clock bits to be omitted from some bit cells with the following prerequisites:

- a. The clock bit is omitted from the current bit cell if either the preceding bit cell or the current bit cell contains a one data bit. See figure 1-7.
- b. In the above mentioned encoding schemes, clock bits are written at the start of their respective bits cells and data bits at the centers of their bit cells.

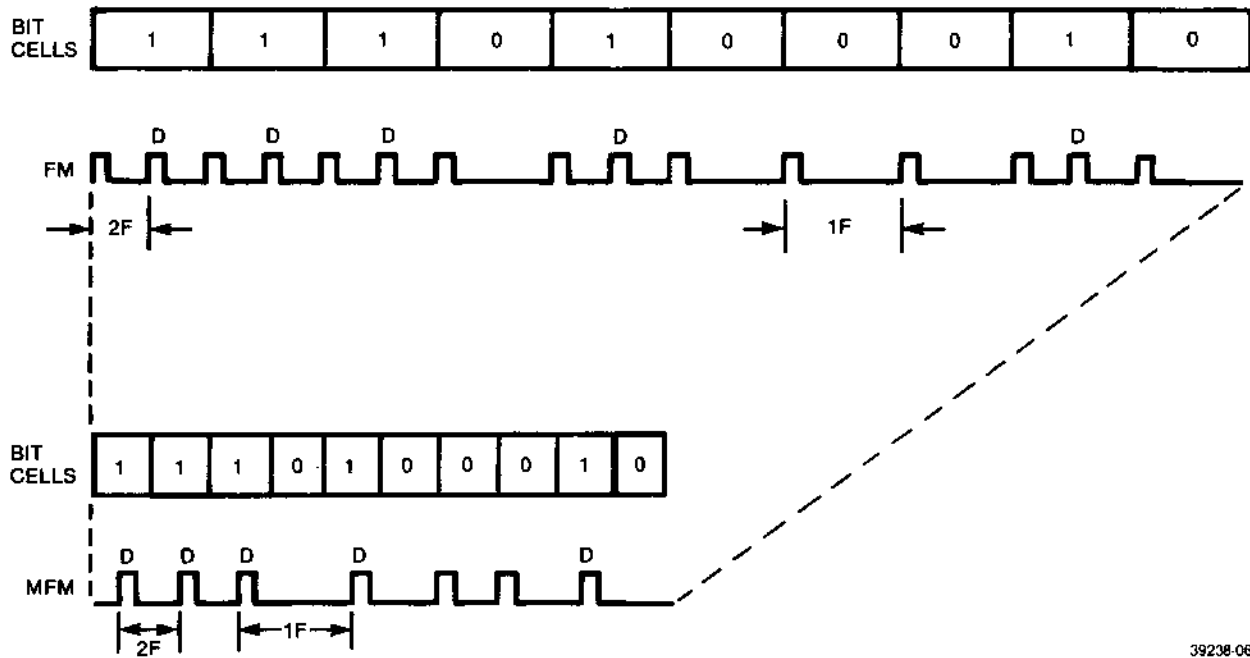

FIGURE 1-7. FM AND MFM CODE COMPARISONS

39238-06

1.4.9 Write Operation

Writing data to the SA455/465 is accomplished by:

- a. Activating the DRIVE SELECT line.
- b. Selecting the head.
- c. Activating the WRITE GATE line.
- d. Pulsing the WRITE DATA line with the data to be written.

The timing relationships required to initiate a Write Data sequence are shown in figure 1-5. These timing specifications are required in order to guarantee that the position of the read/write heads has stabilized prior to writing.

The timing specifications for the write data pulses are shown in figure 1-8. Write data encoding can be FM or MFM. The write data should be precompensated 250 ns starting at track 22 (SA455) or track 40 (SA465) to counter the effects of bit shift. The direction of compensation required for any given bit in the data stream depends on the pattern it forms with nearby bits.

1.4.10 Sequence of Events

The timing diagrams shown in figures 1-3, 1-4, 1-5, and 1-9 show the necessary sequence of events with associated timing restrictions for proper operation.

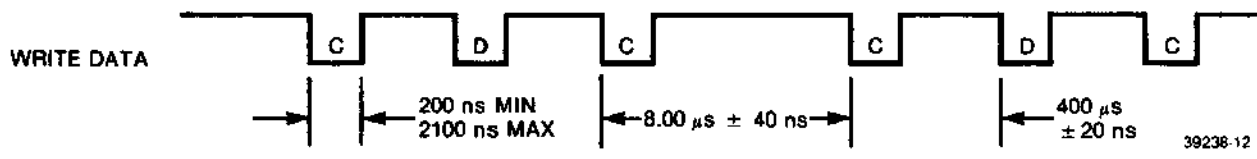

FIGURE 1-8. WRITE DATA TIMING (FM)

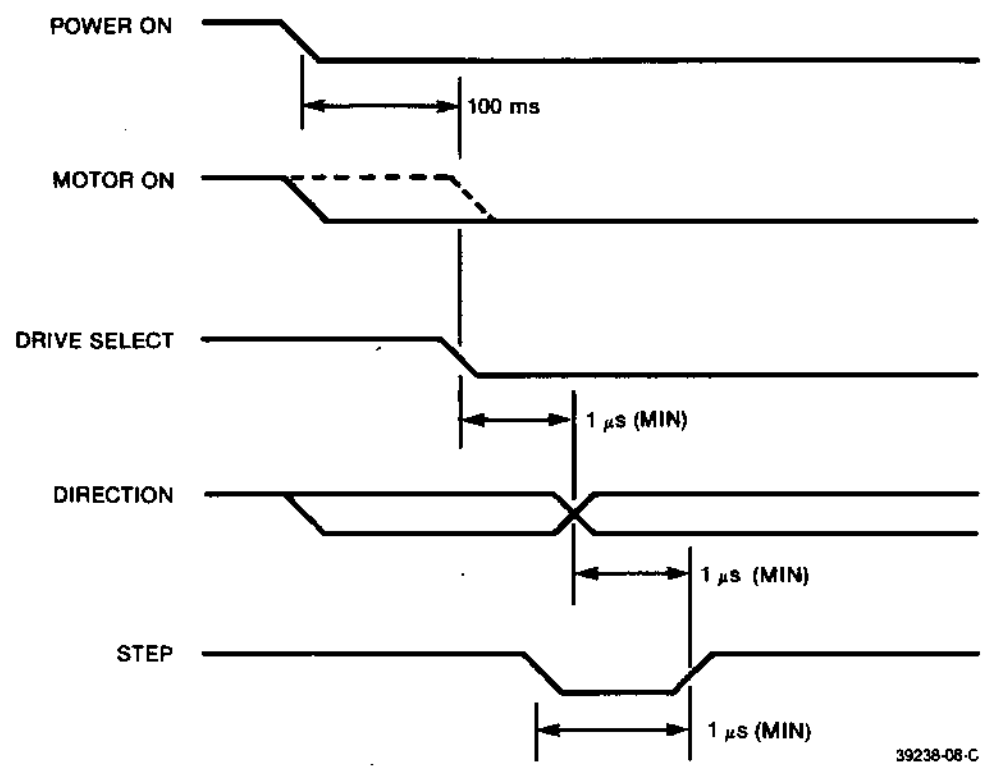

FIGURE 1-9. POWER ON TO STEP

SECTION II ELECTRICAL INTERFACE

2.1 INTRODUCTION

The interface of the SA455/465 can be divided into two categories:

- a. Signal Lines
- b. Power Lines

The following sections provide the electrical definition for each line. See figure 2-1 for all interface connections.

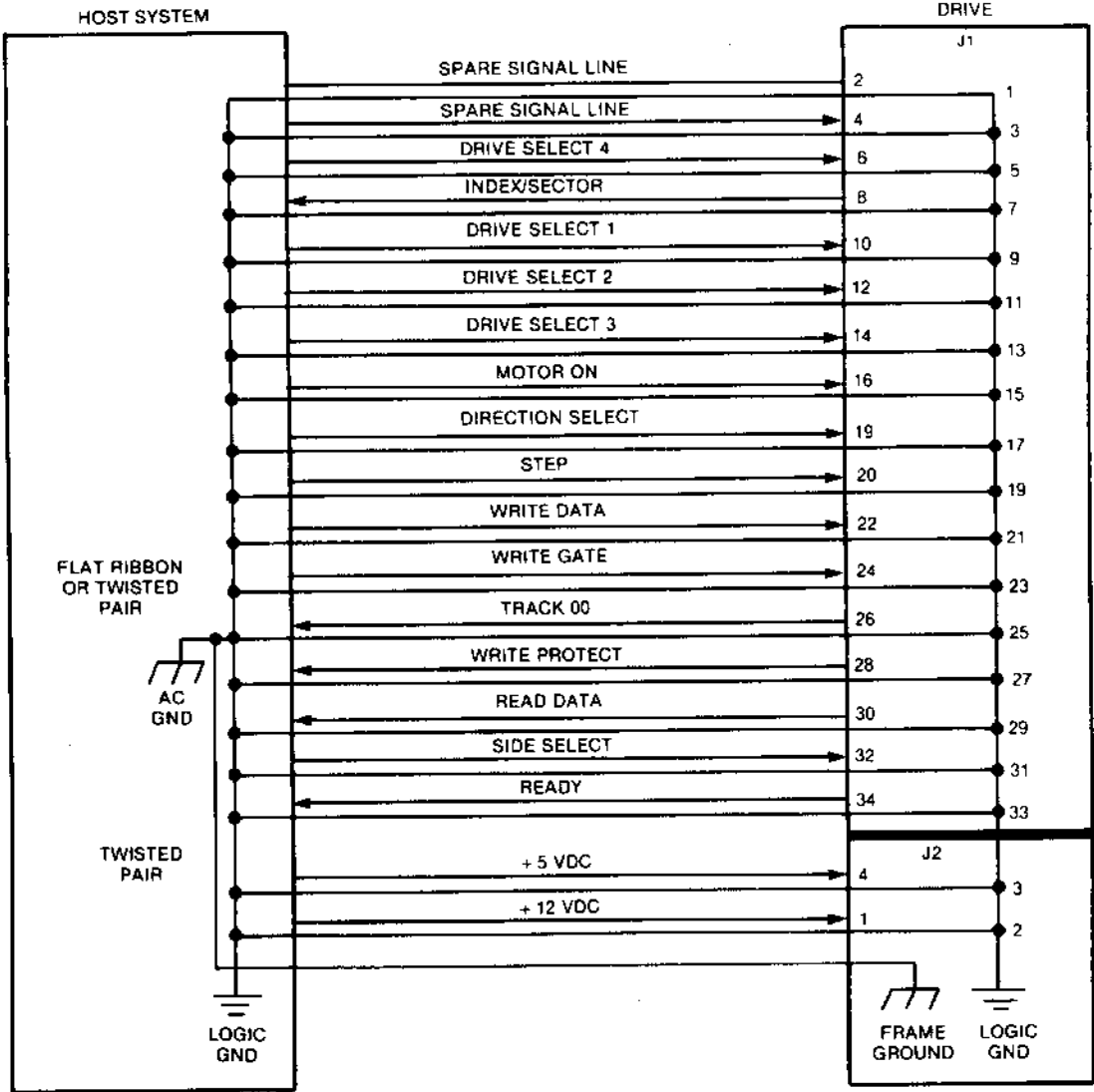

FIGURE 2-1. INTERFACE CONNECTIONS

39238-09-A

2.2 SIGNAL INTERFACE

The signal interface consists of two categories:

- a. Control Lines
- b. Data Transfer Lines

All lines in the signal interface are digital in nature and either provide signals to the drive (input), or provide signals to the host (output), via interface connector P1/J1.

2.2.1 Input Lines

The input signals are of three types: those intended to be multiplexed in a multiple drive system, those which will perform the multiplexing, and those signals which are not multiplexed and affect all the drives in a daisy chain system.

The input signals to be multiplexed are:

- a. DIRECTION SELECT
- b. STEP
- c. WRITE DATA
- d. WRITE GATE
- e. SIDE SELECT

The input signals which are intended to do the multiplexing are:

- a. DRIVE SELECT 1
- b. DRIVE SELECT 2
- c. DRIVE SELECT 3
- d. DRIVE SELECT 4

MOTOR ON is not multiplexed.

The input lines have the following electrical specifications. See figure 2-2 for the recommended circuit.

True = Logical zero = $V_{in} \pm 0.0$ to $+0.4$ V @ $I_{in} = 40$ mA (max)

False = Logical one = $V_{in} + 2.5$ to $+5.25$ V @ $I_{in} = 250$ μ A (open)

Input impedance = 150 ohms

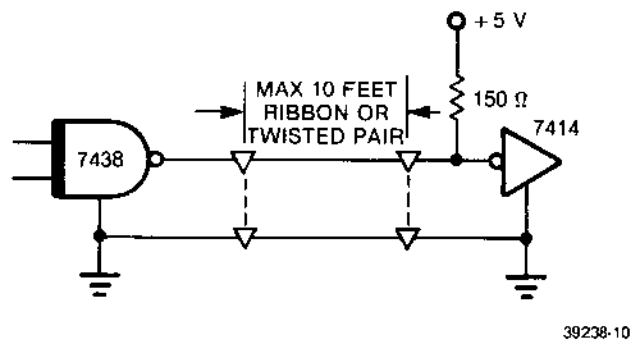

FIGURE 2-2. INTERFACE SIGNAL DRIVER/RECEIVER

2.2.2 Input Line Terminations

The SA455/465 has been provided with the capability of terminating the ten input lines listed below.

- | | |
|-------------------|---------------------|
| 1. DRIVE SELECT 1 | 6. DIRECTION SELECT |
| 2. DRIVE SELECT 2 | 7. STEP |
| 3. DRIVE SELECT 3 | 8. WRITE DATA |
| 4. DRIVE SELECT 4 | 9. WRITE GATE |
| 5. MOTOR ON | 10. SIDE SELECT |

These lines are terminated through a 150 ohm resistor pack. In a single drive system, this resistor pack should be kept in place to provide the proper terminations.

In a multiple drive system, only the last drive on the interface is to be terminated. All other drives on the interface must have the resistor pack removed. External terminations may also be used. However, the user must provide the terminations beyond the last drive and each of the five lines must be terminated to +5 V dc through a 150 ohm, 1/4-watt resistor.

2.2.3 Drive Select 1-4

The SA455/465, as shipped from the factory, is configured to operate in a single drive system. The SA455/465 can be easily modified by the user to operate with other drives in a multiplexed multiple-drive system.

In a multiple drive system, the four input lines (DRIVE SELECT 1 through DRIVE SELECT 4) are provided so that the using system may select which drive on the interface is to be used. In this mode of operation, only the drive with its DRIVE SELECT line active will respond to the input lines and gate the output lines.

2.2.4 Motor On

This input, when activated to a logical zero level, will turn on the drive motor allowing reading or writing on the drive. A 500 ms delay after activating this line must be allowed before reading or writing. This line should be deactivated, for maximum motor life, if no commands have been issued to the drives within 2 seconds (10 revolutions of the media) after completion of a previous command.

2.2.5 Direction Select

This interface line defines the direction of motion the read/write heads will take when the STEP line is pulsed. An open circuit or logical one defines the direction as out. If a pulse is applied to the STEP line, the read/write heads will move away from the center of the disk. Conversely, if this input is shorted to ground or a logical zero level, the direction of motion is defined as in. If a pulse is applied to the STEP line, the read/write heads will move towards the center of the disk.

2.2.6 Step

This interface line is a control signal which causes the read/write heads to move in the direction of motion defined by the DIRECTION SELECT line. This signal must be a logical low going pulse with a minimum pulse width of 1 μ s and then logically high for 5 ms minimum between adjacent pulses. Each subsequent pulse must be delayed by 6 ms (SA455) minimum or 3 ms (SA465) minimum from the preceding pulse.

The access motion is initiated on each logical zero to logical one transition, or at the trailing edge of the signal pulse. Any change in the DIRECTION SELECT line must be made at least 1 μ s before the trailing edge of the STEP pulse. The DIRECTION SELECT logic level must be maintained 1 μ s after the trailing edge of STEP pulse. See figure 2-3 for these timings.

2.2.7 Write Gate

The active state of this signal, or logical zero, enables write data to be written on the diskette. The inactive state or logical one, enables the read data logic and stepper logic. See figure 2-4 for timings.

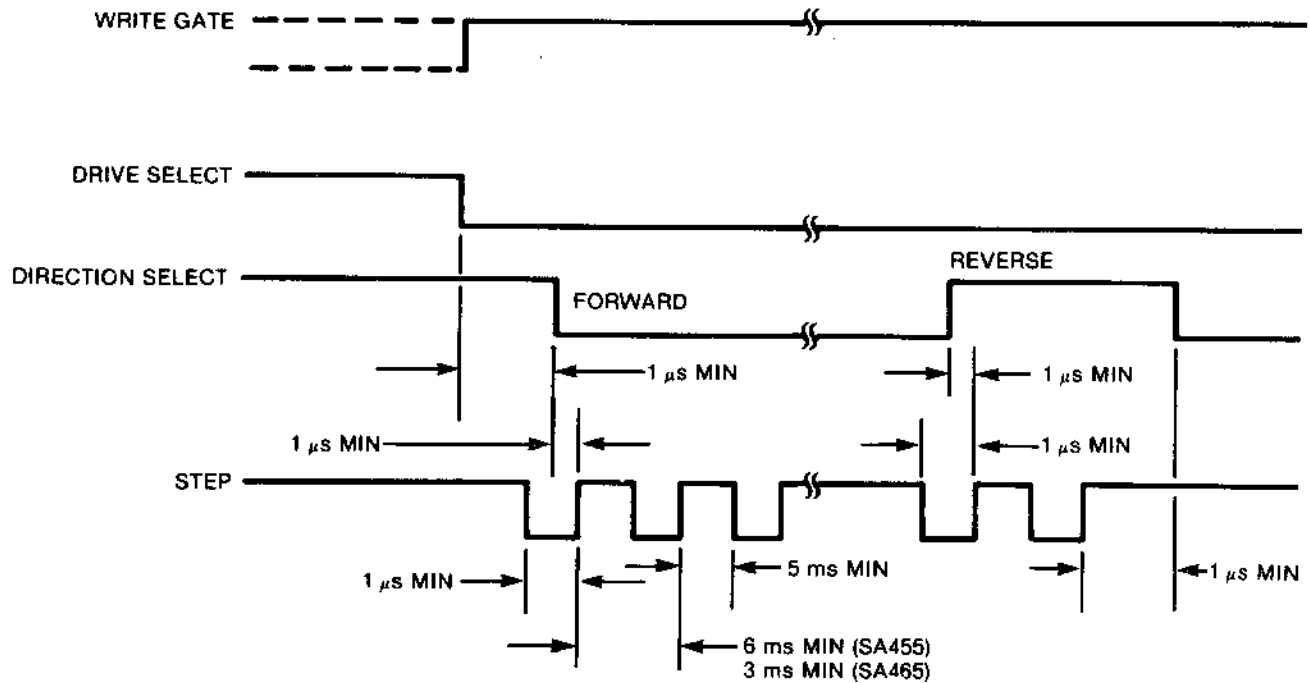

FIGURE 2-3. STEP TIMING

39238-11-A

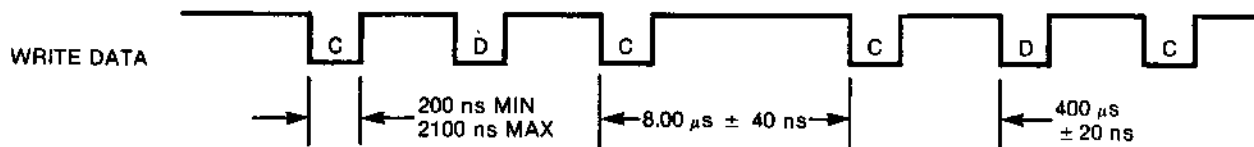

FIGURE 2-4. WRITE DATA TIMING

39238-12

2.2.8 Write Data

This interface line provides the data to be written on the diskette. Each transition from a logical one to a logical zero level, will cause the current through the read/write heads to be reversed thereby writing a data bit. This line is enabled by WRITE GATE being active. Write data must be inactive during a read operation. A write data clamp is provided on the PCB at the interface which holds the WRITE DATA line at a logical zero whenever WRITE GATE is inactive. See figure 2-4 for timings.

2.2.9 Side Select

This signal defines which side of a two-sided diskette is to be written on or read from. A logical one selects the side 0 head. When switching from one side to the other, a 100 μs delay is required before a read or write operation can be initiated.

2.2.10 Output Lines

The output control lines have the following electrical specifications.

True = Logical zero = +0.0 to +0.4 V @ I_{out} = 40 mA (max)

False = Logical one = +5 to +2.5 V (open collector) @ I_{out} = 250 μA (max)

2.2.11 Track 00

The active or logical zero state of this interface signal indicates when the read/write heads are positioned at track zero (the outermost track) and the access circuitry is driving current through phase A of the stepper motor. This signal is at a logical one level, or inactive state, when the read/write heads are not at track zero. When the read/write heads are at track zero and an additional step out pulse is issued to the drive, a mechanical stop will keep the read/write heads at track zero. However, the TRACK 00 signal will go inactive. This is because the stepper motor will go to phase C and not phase A. One more step out pulse will put the stepper motor back into phase A and the TRACK 00 signal will go active again.

2.2.12 Index/Sector

This interface signal is provided by the drive each time an index or sector hole is sensed at the Index/Sector photo detector. Normally, this signal is at a logical one level and makes the transition to the logical zero level each time a hole is sensed.

When using SA154/164 media (soft sectored), there will be one pulse on this interface signal per revolution of the diskette (200 ms). This pulse indicates the physical beginning of a track. See figure 2-5 for the timing.

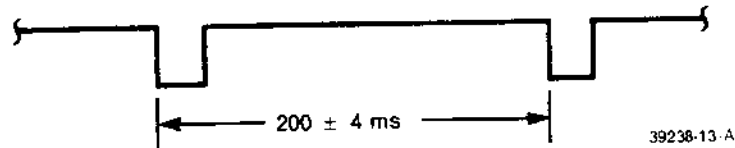

FIGURE 2-5. INDEX TIMING (SA154/164 MEDIA)

When using SA155/165 or SA157/167 media (hard sectored), there will be 17 or 11 pulses on this interface line per revolution (200 ms). To indicate the beginning of a track, once per revolution there is one index transition between 16 or 10 equally spaced sector transitions. The timing for these signals is shown in figures 2-6 and 2-7.

When using the Index/Sector signal, look for an edge or transition rather than a level for determining the status. With no diskette inserted, this signal remains active or at a logical zero level which is an erroneous status.

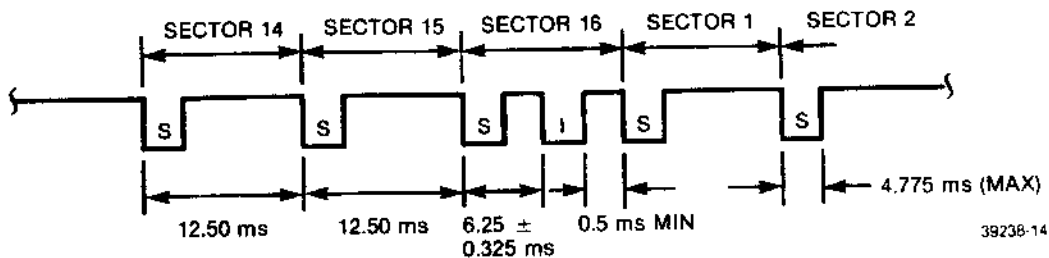

FIGURE 2-6. INDEX/SECTOR TIMING (SA155/165 MEDIA)

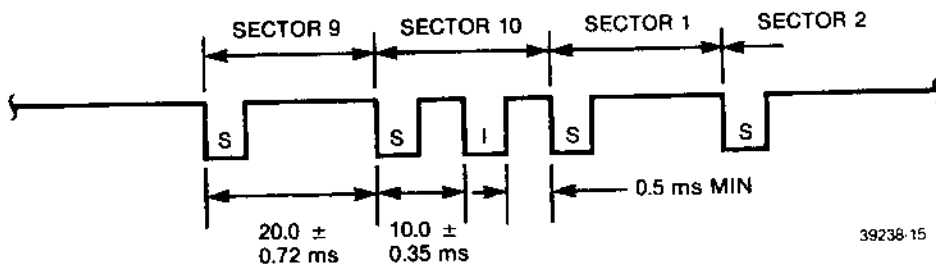

FIGURE 2-7. INDEX/SECTOR TIMING (SA157/167 MEDIA)

2.2.13 Read Data

This interface line provides the raw data (clock and data together) as detected by the drive electronics. Normally, this signal is a logical one level and becomes a logical zero level for the active state. See figure 1-5 for the timing and bit shift tolerance within normal media variations.

2.2.14 Write Protect

This interface signal is provided by the drive to give the user an indication when a write protected diskette is installed. The signal is logical zero level when it is protected. Under normal operation, the drive will inhibit writing with a protected diskette installed in addition to notifying the interface.

2.2.15 Ready

READY informs the controller that a diskette is properly inserted and that the drive motor is up to speed. 500 ms is required for starting the motor and an additional 200 ms is required for one revolution at the rated speed. Thus, READY is available 700 ms after power is applied to the motor. The SA455/465 generates READY by sensing index pulses and measuring their frequency of occurrence. When the index pulses are 200 ms apart, READY becomes active.

2.3 POWER INTERFACE

The SA455/465 requires only dc power for operation. DC power to the drive is provided via P2/J2. The two dc voltages, their specifications, and their P2/J2 pin designators are outlined in table 2-1. The specifications outlined on current requirements are for one drive. For multiple drive systems, the current requirements are a multiple of the maximum current times the number of drives in the system.

TABLE 2-1. DC POWER REQUIREMENTS

P2 PIN	DC VOLTAGE	TOLERANCE	CURRENT	MAX RIPPLE (p to p)
1	+ 12 VDC	± 1.2 VDC	1.2 A MAX 0.6 A TYP	50 mV MAX ALLOWABLE
2	+ 12 RETURN			
3	+ 5 RETURN			
4	+ 5 VDC	± 0.25 VDC	0.9 A MAX 0.6 A TYP	50 mV MAX ALLOWABLE

39238-17-A

2.4 FRAME GROUND

It is important that the drive be frame grounded to the host system ac ground or frame ground. Failure to do so may result in drive noise susceptibility.

SECTION III PHYSICAL INTERFACE

3.1 INTRODUCTION

The electrical interface between the SA455/465 and the host system is via two connectors. The first connector, J1, provides the signal interface. The second connector, J2, provides the dc power.

This section describes the physical connectors used on the drive and recommended connectors to be used with them. See figure 3-1 for connector locations.

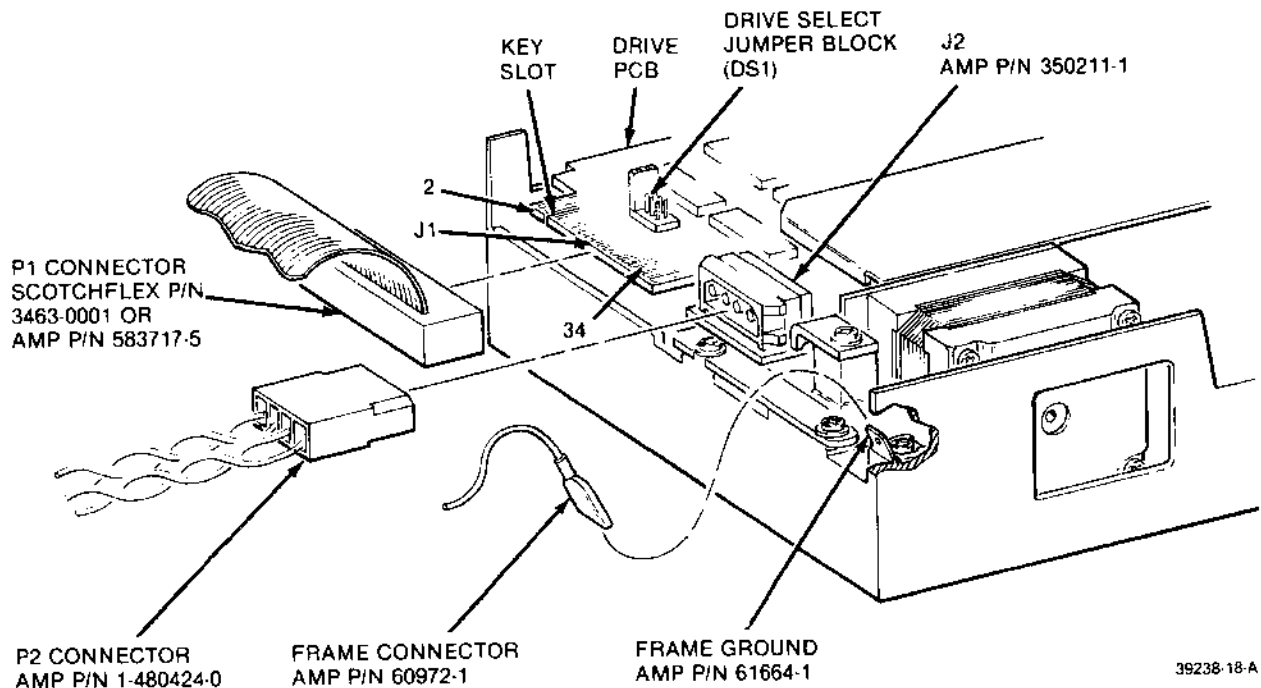

FIGURE 3-1. INTERFACE CONNECTORS PHYSICAL LOCATIONS

3.1.1 J1/P1 Connector

Connection to J1 is through a 34 pin PCB edge connector. The dimensions for this connector are shown in figure 3-2. The pins are numbered 1 through 34 with the even numbered pins on the component side of the PCB. The odd numbered pins are on the non-component side. Pin 2 is located on the end of the PCB connector closest to the corner and is labeled 2. A key slot is provided between pins 4 and 6 for optional connector keying.

3.1.2 J2/P2 Connector

The dc power connector, J2, is a 4 pin AMP Mate-N-Lok connector (P/N 350211-1). The recommended mating connector, P2, is AMP P/N 1-480424-0 using AMP pins P/N 61473-1. J2, pin 1, is labeled on the component side of the PCB. Wire used should be #18 AWG. Figure 3-3 illustrates the J2 connector as seen on the drive PCB from the non-component side.

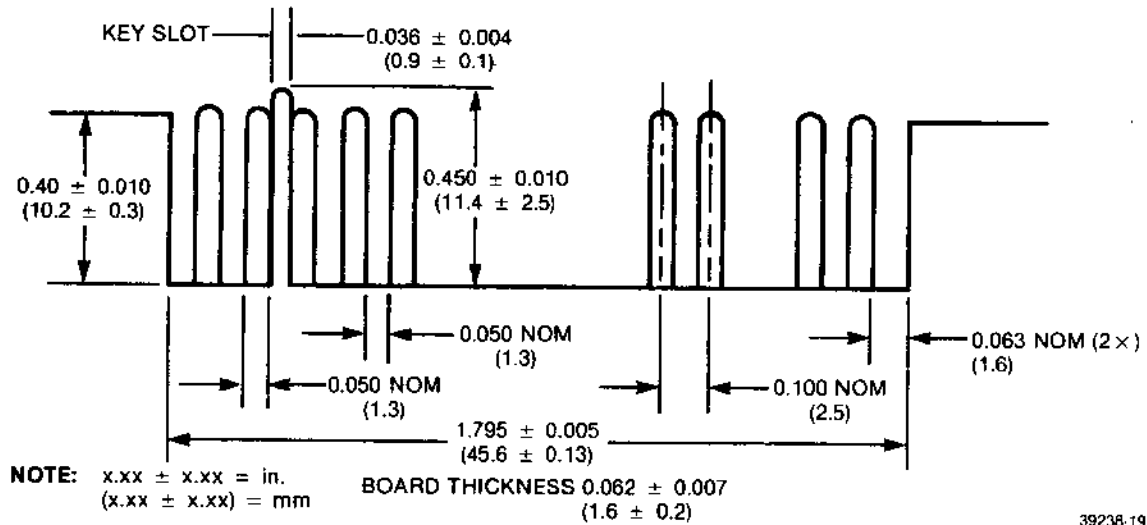

FIGURE 3-2. J1 CONNECTOR DIMENSIONS

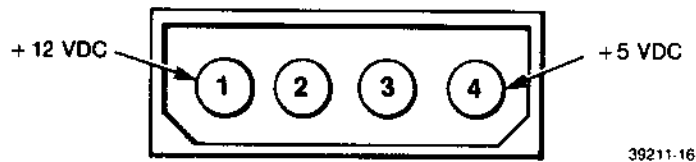

FIGURE 3-3. J2 CONNECTOR

3.2 FRAME GROUNDING

CAUTION

The SA455/465 must be frame grounded to the host system to ensure proper operation. If the frame of the drive is not fastened directly to the frame of the host system with a good ac ground, a wire from the system ac frame ground must be connected to the SA455/465. For this purpose, a faston tab is provided on the drive near the motor control PCB where a faston connector can be attached or soldered. The tab is AMP P/N 61664-1 and its mating connector is AMP P/N 60972-1.

SECTION IV THEORY OF OPERATION

4.1 THEORY OF OPERATION

The SA455/465 floppy diskette drive electronics are packaged on one PCB which contains:

- a. Read/Write Amplifier and Transition Detector
- b. Spindle Motor Control
- c. Drive Select Circuits
- d. Index Detector Circuits
- e. Track Zero Circuits
- f. Track Accessing Circuits
- g. Power On Reset Control
- h. Write Protect Circuits
- i. Drive Status Circuits

The head positioning actuator moves the read/write head(s) to the desired track on the diskette. The head(s) is loaded onto the diskette when the door is closed.

The following paragraphs describe each of the above functions in detail.

4.2 READ/WRITE OPERATIONS

- a. The SA455/465 uses the double frequency non return to zero (NRZ) recording method.
- b. The read/write head, in general, is a ring with a gap and a coil wound at some point on the ring.
- c. During a write operation, a bit is recorded when the flux direction in the ring is reversed by rapidly reversing the current in the coil.
- d. During a read operation, a bit is read when the flux direction in the ring is reversed as a result of a flux reversal on the diskette surface.

The SA455/465 drives use the double-frequency (2F) longitudinal NRZ method of recording. Double frequency is the term given to the recording system that inserts a clock bit at the beginning of each bit cell thereby doubling the frequency of recorded bits. This clock bit, as well as the data bit, is provided by the using system. See figure 4-1.

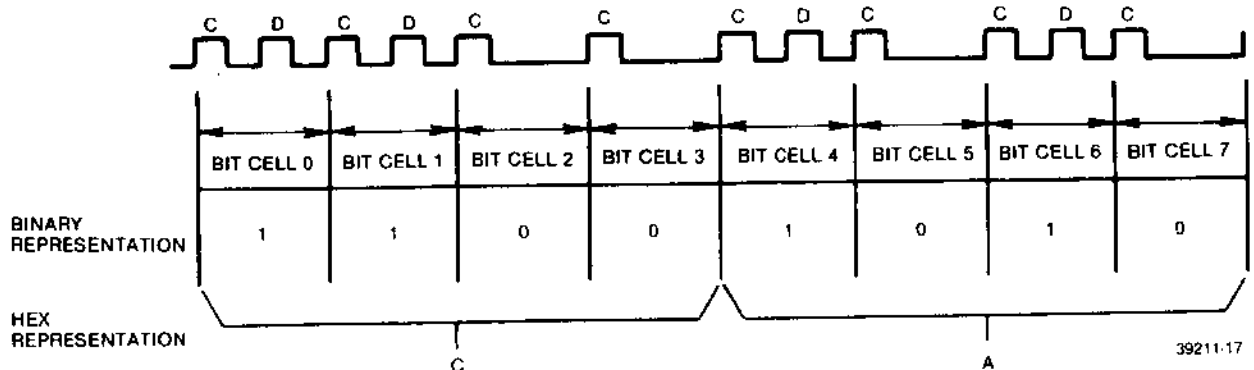

FIGURE 4-1. BYTE

The read/write head is a ring with a gap and a coil wound some point on the ring. When current flows through the coil, the flux induced in the ring fringes at the gap. As the diskette recording surface passes by the gap, the fringe flux magnetizes the surface in a longitudinal direction. See figure 4-2.

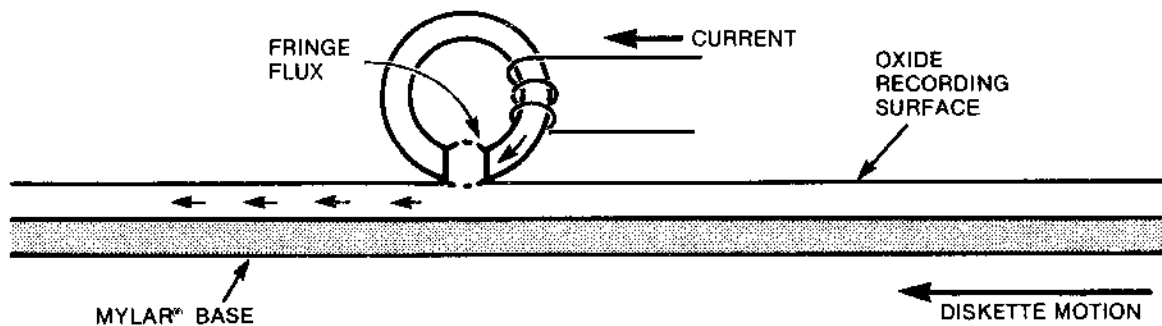

FIGURE 4-2. BASIC READ/WRITE HEAD

39211-18

The drive writes two frequencies: 1F 62.5 k Hz and 2F 125 k Hz. During a write operation, a bit is recorded when the flux direction in the ring is reversed by rapidly reversing the current in the coil. The fringe flux is reversed in the gap and hence the portion of the flux flowing through the oxide recording surface is reversed. If the flux reversal is instantaneous in comparison to the motion of the diskette, it can be seen that the portion of the diskette surface that just passed under the gap is magnetized one direction while the portion under the gap is magnetized in the opposite direction. This flux reversal represents a bit. See figure 4-3.

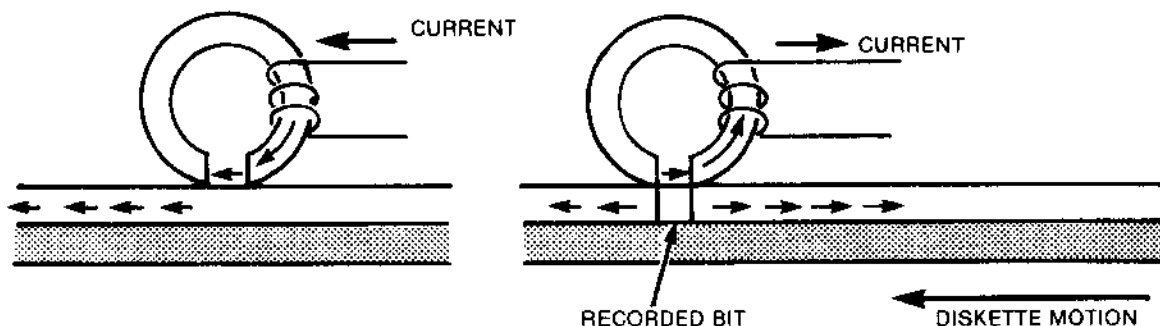

FIGURE 4-3. RECORDED BIT

39211-19

During a read operation, a bit is read when the flux direction in the ring is reversed as a result of a flux reversal on the diskette surface. The gap first passes over an area that is magnetized in one direction and a constant flux flows through the ring and coil. The coil registers no output voltage at this point. When a recorded bit passes under the gap, the flux flowing through the ring and coil will make a 180° reversal. This means that the flux reversal in the coil will cause a voltage output pulse. See figure 4-4.

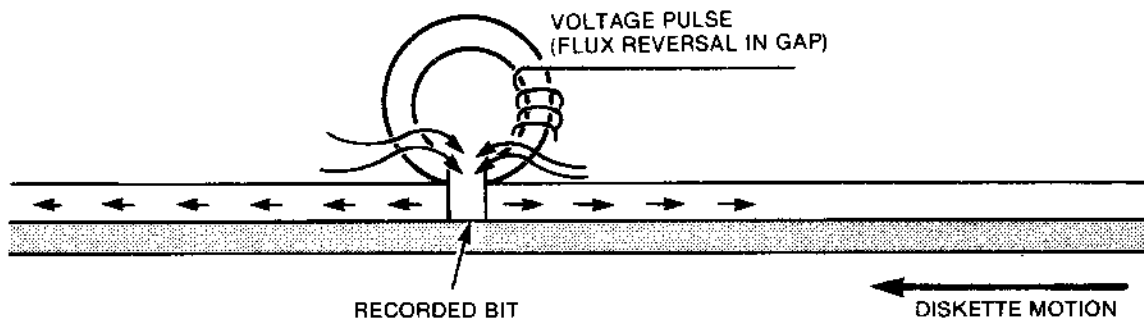

FIGURE 4-4. READING A BIT

39211-20

These flux reversals produce an FM waveform which transmits data to and from the diskette. See figure 4-5.

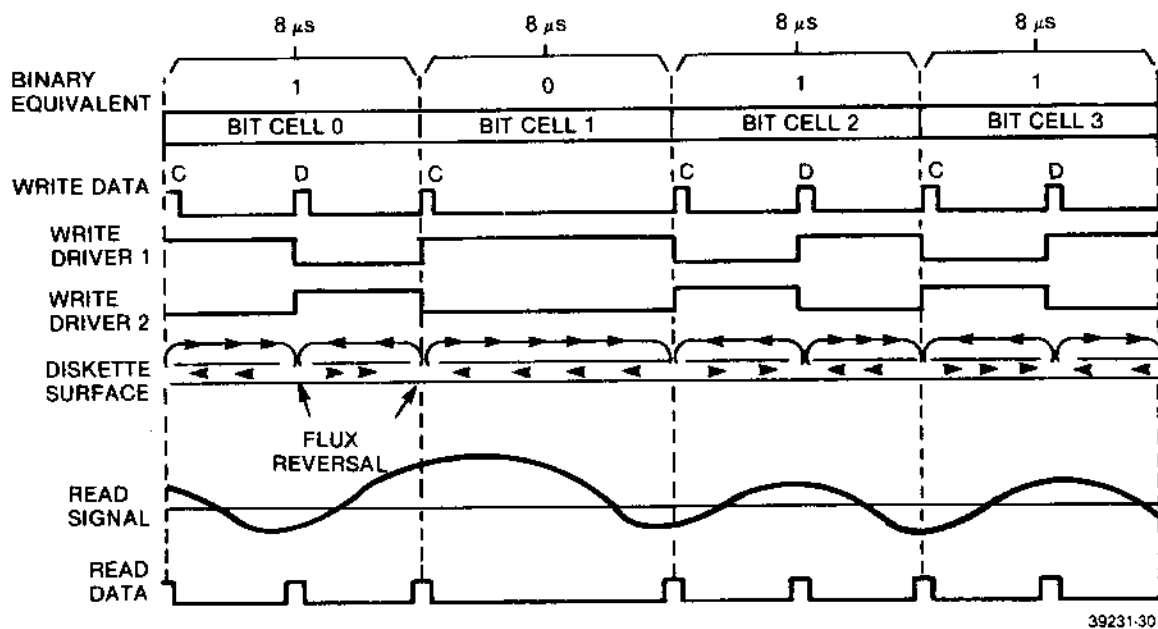

FIGURE 4-5. 1F AND 2F RECORDING FLUX AND PULSE RELATIONSHIP

4.3 READ/WRITE HEAD

- a. The ceramic read/write heads each contain three coils.
- b. When writing, the head erases the outer edges of the track to ensure that the data recorded will not exceed the 0.012 in. (SA455) or 0.006 (SA465) track width.

The read/write head contains three coils. Two read/write coils are wound on a single core, center tapped, and one erase coil is wound on a yoke that spans the track being written. The read/write and erase coils are connected as shown in figure 4-6.

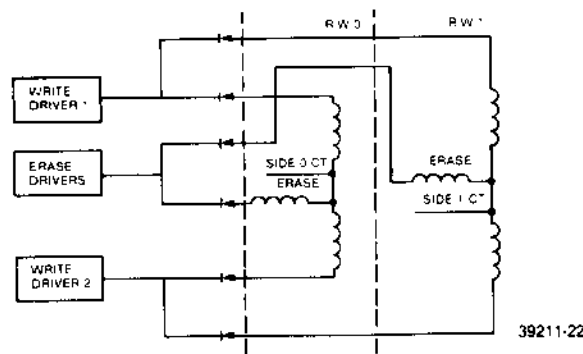

FIGURE 4-6. READ/WRITE HEADS

During a write operation, the erase coil is energized. This causes the outer edges of the track to be trim erased so that the track being recorded will not exceed the 0.012 in. (SA455) or 0.006 in. (SA465) track width. Tunnel erasing allows for minor deviations in read/write head current so as one track is recorded, it will not "splash over" to adjacent tracks.

Each bit written will be directed to alternate read/write coils, thus causing a change in the direction of current flow through the read/write head. This will cause a change in the flux pattern for each bit. The current through either of the read/write coils will cause the old data to be erased as new data is recorded.

During a read operation, the direction of flux changes on the diskette surface as it passes under the gap and current is induced into one of the windings of the read/write head. This results in a voltage output pulse. When the next data bit passes under the gap, another flux change takes place in the recording surface. This causes current to be induced in the other coil, producing another voltage output pulse of the opposite polarity.

4.5 READ CIRCUIT OPERATION

- a. Duration of all read operations is under control of the using system.
- b. As long as the drive is selected and WRITE GATE is not active, the read signal is amplified and shaped and the square wave signals are sent to the interface as READ DATA.

When the using system requires data from the diskette drive, the using system must select the head and disable WRITE GATE. The read signal is then fed to the amplifier section of the read circuit. After amplification, the read signal is fed to a filter where the out of band noise is removed. The read signal is then fed to the differentiator amplifier.

Since a clock pulse occurs at least once every 8 μ s and data bits are present once every 4 μ s, the frequency of the READ DATA varies (FM encoding only). The read signal amplitude decreases as the frequency increases. Note the signals in figure 4-8. The differential amplifier will amplify, differentiate, limit, and digitize the read signals (sine waves).

The drive has no data separator, only a pulse standardizer for the READ DATA signal.

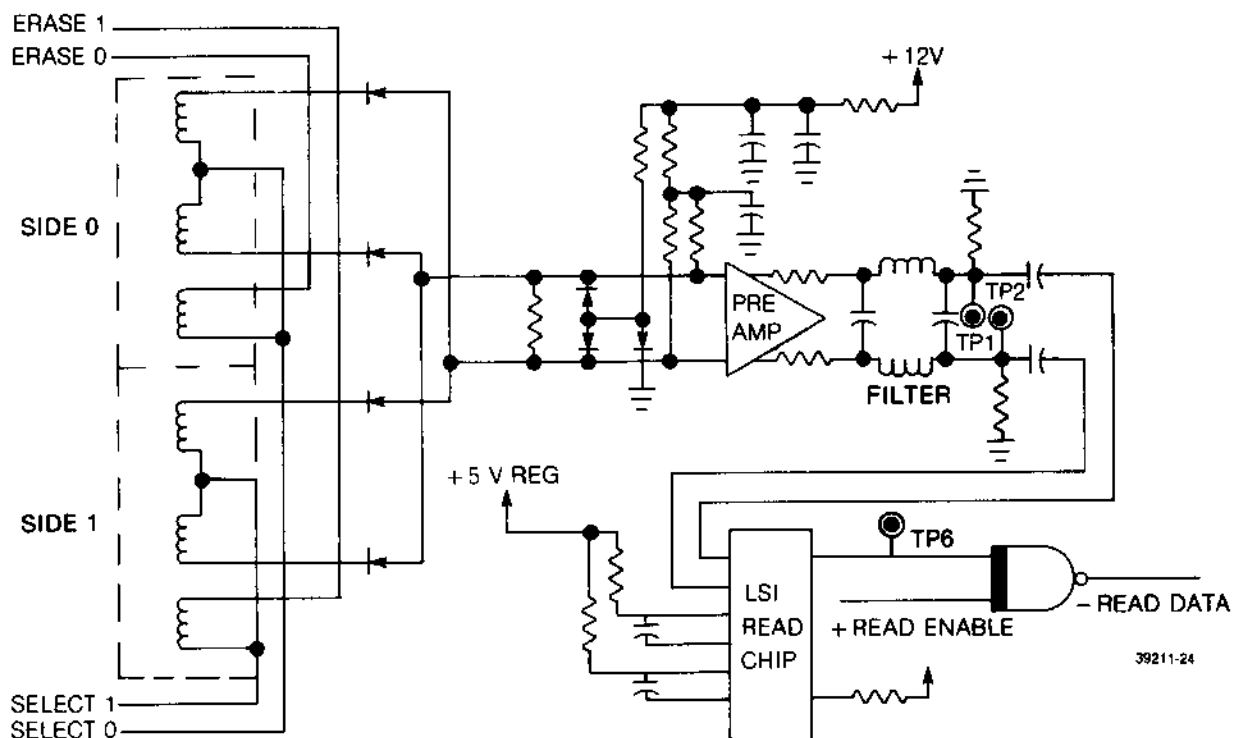

FIGURE 4-8. READ CIRCUIT

4.6 DRIVE MOTOR CONTROL

- a. Start/Stop
- b. Speed Control
- c. Over Current Protection
- d. Speed Adjustment

The motor used in the SA455/465 is a dc drive motor with a separate motor on and off interface line. After activating the MOTOR ON line, a 500 ms delay must be introduced to allow proper motor speed before reading or writing.

When MOTOR ON is activated at pin 16 of the interface, the mode will start by means of current flow through the motor windings. The motor speed control utilizes an integral brushless tachometer. The output voltage signal from this tachometer is compared to a voltage/frequency reference level. The output from the voltage/frequency comparator will control the necessary current to maintain a constant motor speed of 300 rpm. Motor speed adjustment changes the voltage reference through a potentiometer.

4.7 INDEX DETECTOR

Each time an index or sector hole is moved past the index photo detector, a pulse is formed. This pulse is present on the interface as index/sector pin 8. Without a diskette in the drive, the output line will be low and the using system must look for a transition to be a valid signal. The detector output is fed into a schmidt trigger with a level trigger latch back to maintain pulse stability while shaping the pulse. With output enable true, this pulse will be on the interface as a negative going pulse. See figure 4-9.

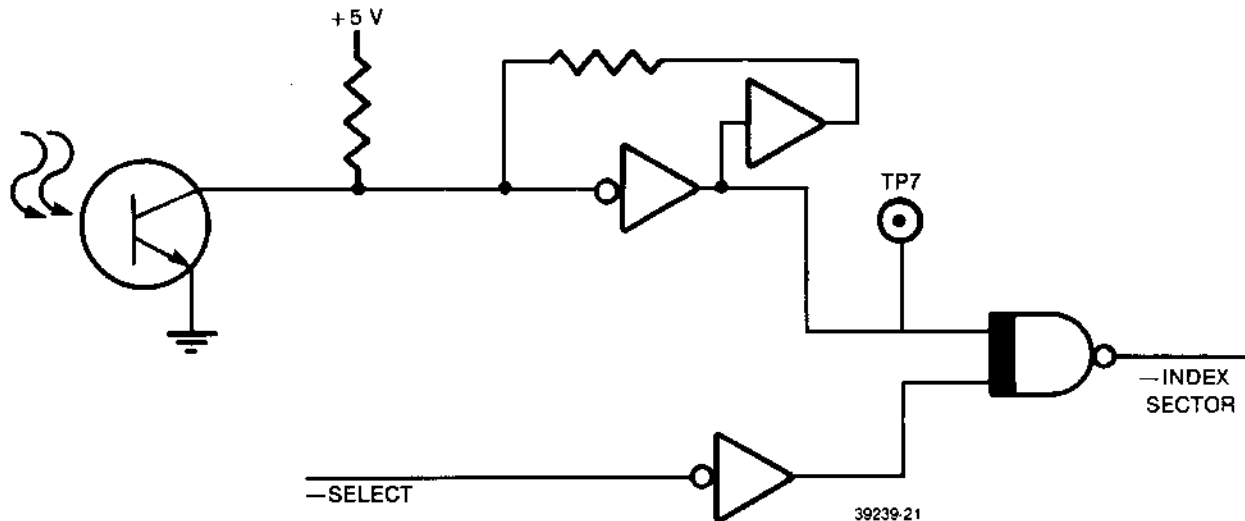

FIGURE 4-9. INDEX DETECTOR

4.8 TRACK ZERO INDICATION

Track 00 signal (pin 26) is provided to the using system to indicate when the read/write head is positioned on track 00. The track 00 indication is provided when the flag attached to the head carriage passes between the photo transistor and the photo detector. On track, DRIVE SELECT is ANDed with the photo detector output. These conditions will cause a track 00 indication to the interface.

4.9 TRACK ACCESSING

- Stepper Motor (Four Phase)
- Stepper Control Logic
- Reverse Seek
- Forward Seek

Seeking the read/write head from one track to another is accomplished by selecting the desired direction utilizing the DIRECTION SELECT interface line, loading the read/write head, and pulsing the STEP line. Multiple track accessing is accomplished by repeated pulsing of the STEP line with WRITE GATE inactive until the desired track has been reached. Each pulse on the STEP line will cause the read/write head to move one track either in or out, depending on the DIRECTION SELECT line.

4.9.1 Stepper Motor

The four phase stepper motor turns the head actuator cam in two step increments per track for the 455 and one step increments for the 465. The band actuator and capstan move the heads track to track.

Two current modes are automatically enabled. The first step pulse will enable full current to the stepper motor. Within 35 ms after that last step pulse is issued, stepper motor current is automatically decreased to approximately 50% of its full value.

4.9.2 Stepper Control

During power on reset time, the stepper control counter is reset to zero. This causes phases -B and -A to be energized in the stepper. Figures 4-10 and 4-11 show the stepper control logic and timing.

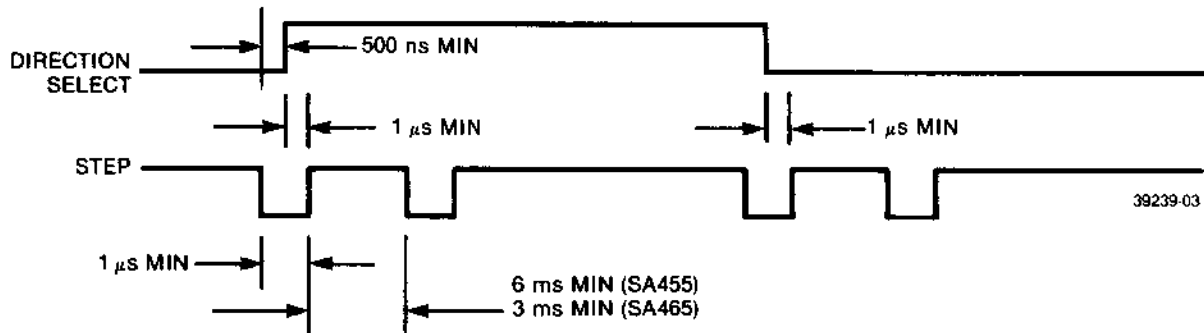

FIGURE 4-10. STEPPER TIMING

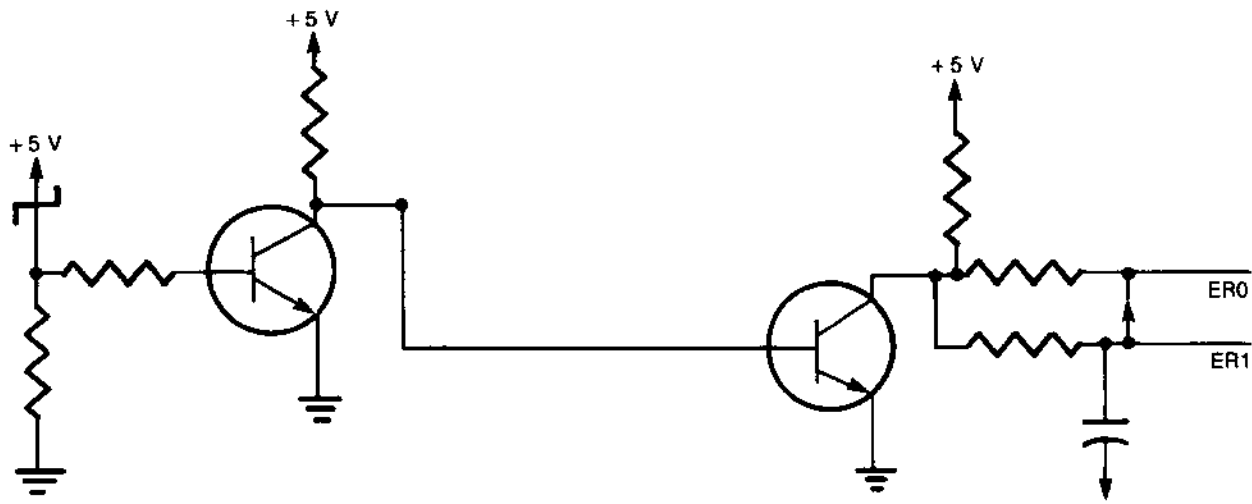

FIGURE 4-11. POWER ON RESET

4.10 DRIVE SELECT

The SA455/465 is configured to operate alone in a single drive system. It can be easily modified to operate with other drives in a daisy chained multiplexed drive system. This is done by selecting the specific drive address and jumpering the appropriate DRIVE SELECT line. See figure 4-12.

The "MX" option is used for single drive systems. By shorting "MX," the I/O lines are always enabled.

The "MS" option allows the motor to be enabled from DRIVE SELECT.

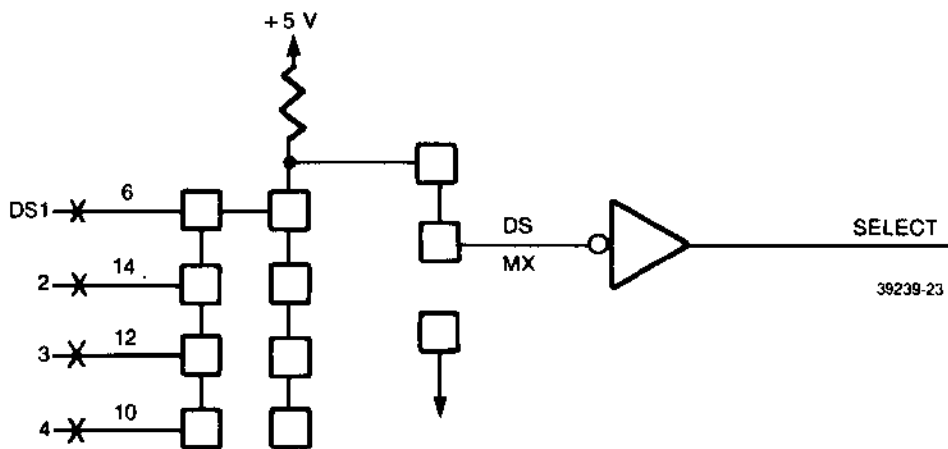

FIGURE 4-12. DRIVE SELECT

4.11 WRITE PROTECT

This interface signal is provided by the drive to indicate to the user when a write protected diskette is installed. The signal is logical 0 level when it is protected. Under normal operation, the drive will inhibit writing with a protected diskette installed in addition to notifying the interface. If the "WP" trace is cut, writing to the diskette is inhibited unless a write protect label is installed over the notch. See figure 4-13.

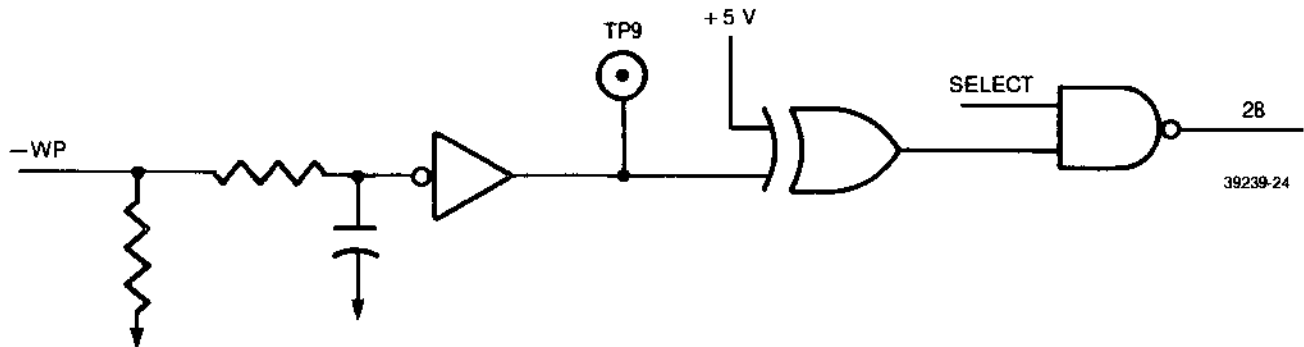

FIGURE 4-13. WRITE PROTECT

4.12 READY

This interface signal gives the user an indication that a diskette is inserted correctly in the drive and the door is closed. The READY signal is active, at a logical 0 level, when all of the following conditions are met:

- a. The door is closed.
- b. The door has not been opened since the drive was last deselected and timed out 500 ms.
- c. Two INDEX/SECTOR pulses have been sensed since the previous conditions were met.

If the READY signal is inactive, the user may deselect and then select the drive to test READY again; if the door had previously been disturbed but is now closed, READY will activate upon sensing an INDEX/SECTOR pulse.

SECTION V MAINTENANCE

5.1 MAINTENANCE EQUIPMENT

5.1.1 Alignment Diskette

The alignment diskette is used for verifying and adjusting the SA455/465. Two alignment diskettes are available. The SA455/465 has two read/write heads and requires written information on both surfaces. The SA128 (48 tpi) alignment diskette should be used when performing service checks on the SA455. The SA465 requires the SA126 (96 tpi) alignment diskette.

The following adjustments and checks can be made using the SA128/126 alignment diskettes.

	SA455-SA128	SA465-SA126
a. Read/Write Head Radial Alignment	TRK 33	TRK 64
b. Index Photo Detector Alignment	Set at TRK 38 Verified at TRK 01	Set at TRK 76 Verified at TRK 02
c. Track 00 Head Position	TRK 00	TRK 00
d. Azimuth Angle (not field adjustable)	TRK 33	TRK 64
e. 125 k Hz Signal Recorded to Check Head Position on Inside Track	TRK 34	TRK 79

Caution should be used not to destroy prerecorded alignment tracks. The write protect tab must be installed to prevent accidental writing on the alignment diskette. If the write protect option is used, remove the write protect tab.

5.1.2 Exerciser PCB

The exerciser PCB can be used in a stand alone mode, built into a test station, or used in a test for field service.

The exerciser will enable the user to make all adjustments and check outs required on the SA455/465 minidiskette drive. It has no intelligent data handling capabilities but can write a 2F 125 k Hz signal which is the recording frequency used for amplitude checks on the SA455/465 drive. The exerciser can start and stop the drive motor, and enable read in the SA455/465 to allow checking for proper read back signals.

5.1.3 Special Tools

The following special tools are available for performing maintenance on the SA455/465.

Description	Part Number
SA128 Alignment Diskette	54573
SA126 Alignment Diskette	54382
Exerciser PCB	54157
Head Cable Extender	54578
Phillips Screw Drivers	Medium and Small
Oscilloscope	Textronix 465 or equivalent

5.2 DIAGNOSTIC TECHNIQUES

5.2.1 Introduction

Incorrect operating procedures, faulty programming, damaged diskettes, and "soft errors" created by airborne contaminants, random electrical noise, and other external causes can produce errors falsely attributed to drive failure or misadjustment. Unless visual inspection of the drive discloses an obvious misalignment or broken part, attempt to repeat the fault with the original diskette, then attempt to duplicate the fault on a second diskette.

5.2.2 "Soft Error" Detection and Correction

Soft errors are usually caused by:

- Airborne contaminants that pass between read/write heads and disk. Usually these contaminants can be removed by cartridge self-cleaning wiper.
- Random electrical noise that usually lasts for a few microseconds.
- Small defects in written data and/or track not detected during write operation may cause soft errors during read.
- Improper grounding of power supply, drive, and/or host system. Refer to SA455/465 OEM manual (P/N 39238) for proper grounding requirements.
- Improper motor speed.

The following procedures are recommended to recover from the above mentioned soft errors:

- Reread track 10 times or until such time as data is recovered.
- If data is not recovered after using step (a), access head to adjacent track in same direction previously moved, then return to desired track.
- Repeat step (a).
- If data is not recovered, error is not recoverable.

5.2.3 Write Error

If an error occurs during a write operation, it will be detected on the next revolution by doing a read operation, commonly called a "write check." To correct the error, another write and check operation must be done. If the write operation is not successful after 10 attempts have been made, a read operation should be attempted on another track to determine if the media or the drive is failing. If the error persists, the diskette should be replaced and the above procedure repeated. If the failure still exists, consider the drive defective. If the failure disappears, consider the original diskette defective and discard it.

5.2.4 Read Error

Most errors that occur will be "soft errors." In these cases, performing an error recovery procedure will recover the data.

5.2.5 Seek Error

- a. Stepper malfunction.
- b. Carriage binds.
- c. To recover from a seek error, recalibrate to track 00 and perform another seek to the original track or do a read ID to find on which track the head is located.

5.3 TROUBLE-SHOOTING

Figures 5-1 through 5-5 provide trouble-shooting procedures for the SA455/465.

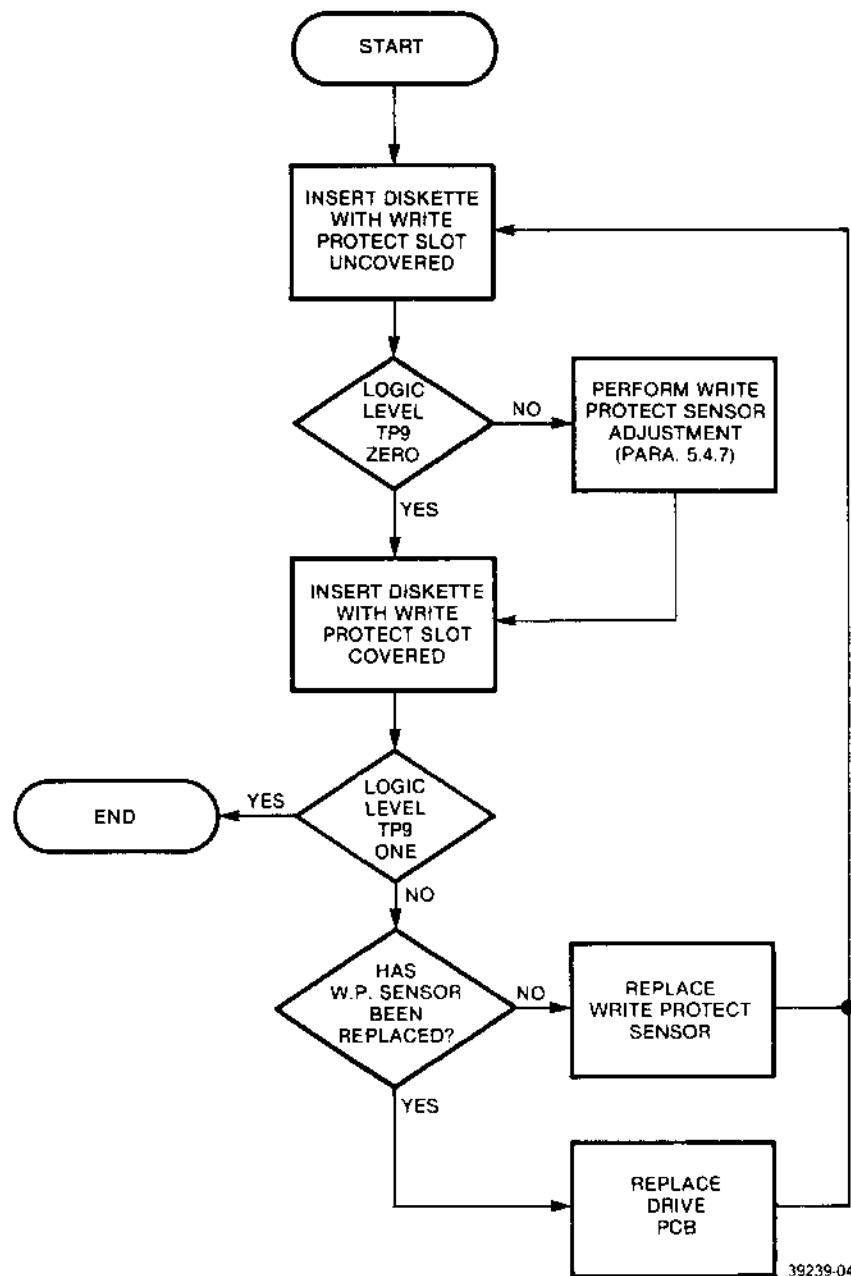
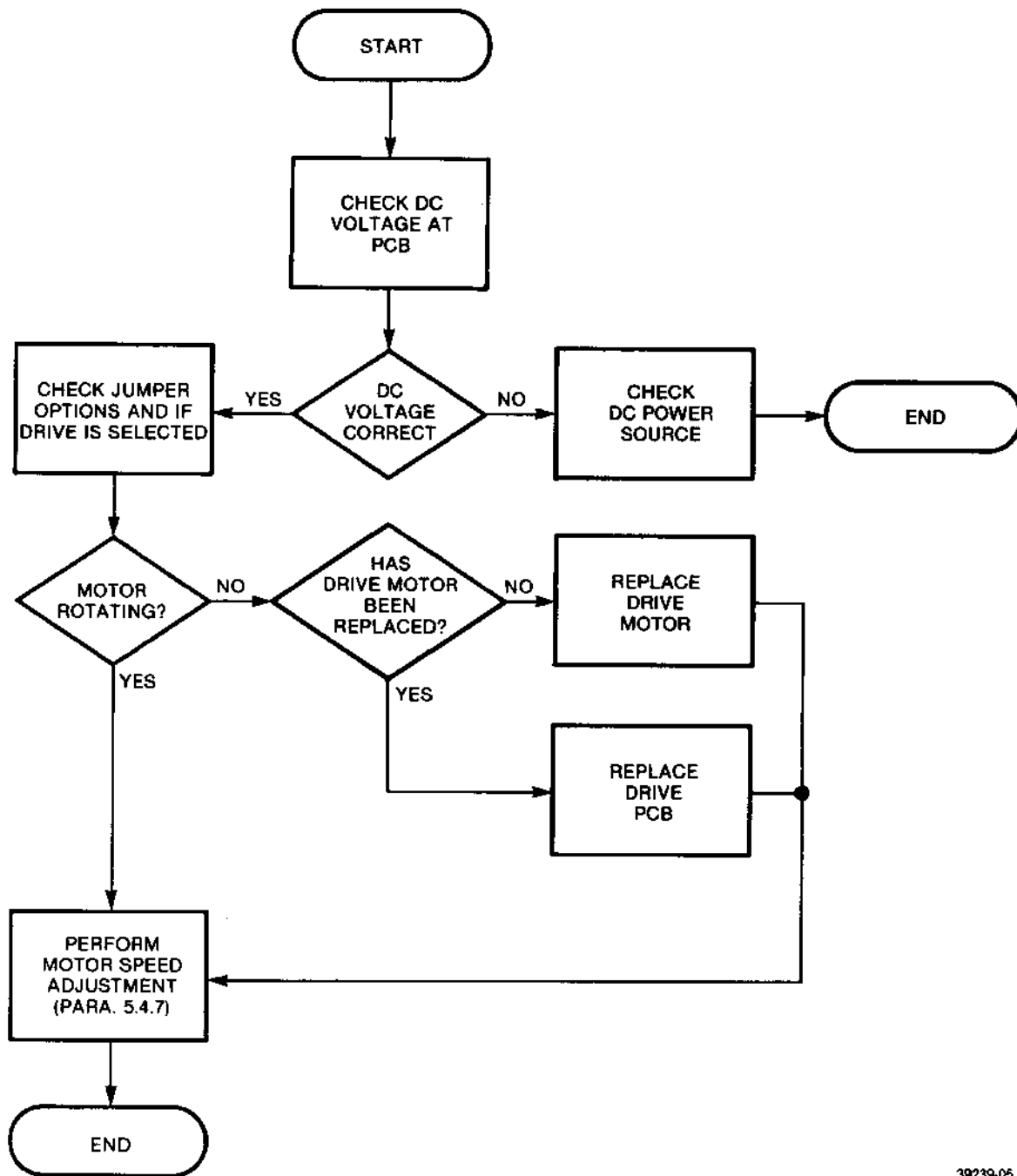
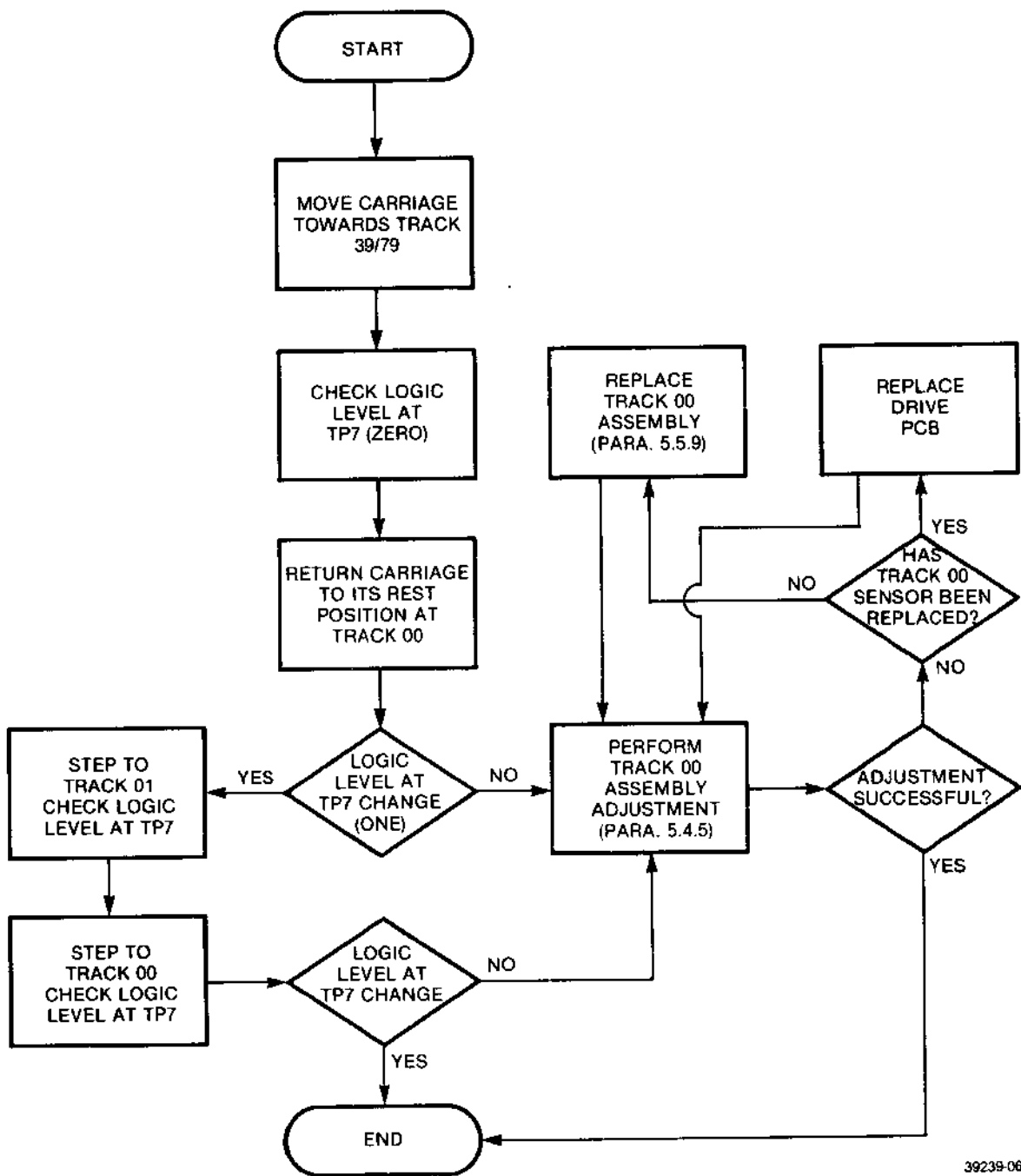

FIGURE 5-1. WRITE PROTECT INOPERATIVE



39239-05

FIGURE 5-2. DISKETTE NOT ROTATING



39238-06

FIGURE 5-3. TRACK 00 INDICATOR INOPERATIVE

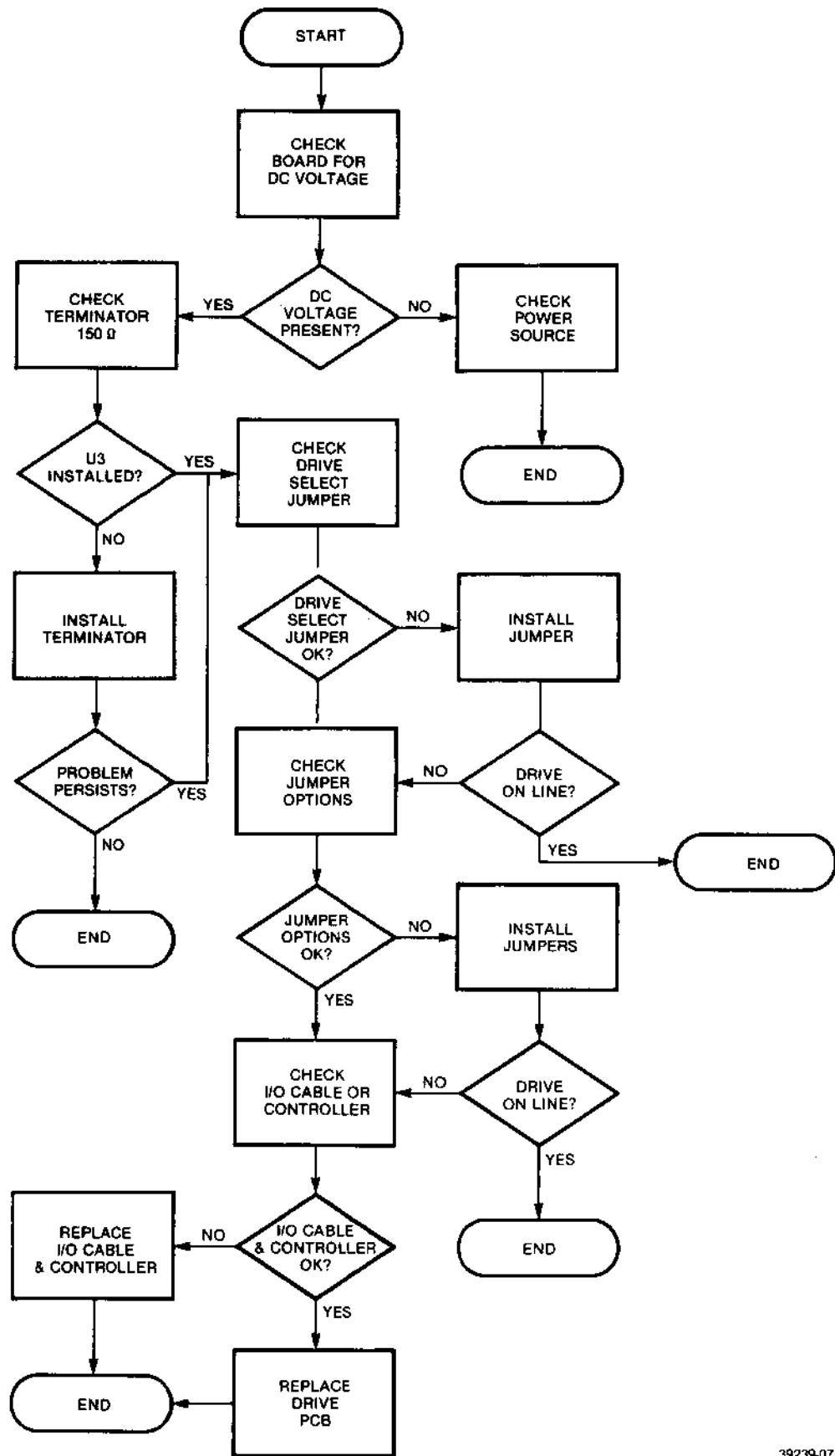

39239-07

FIGURE 5-4. DRIVE NOT COMING ON LINE

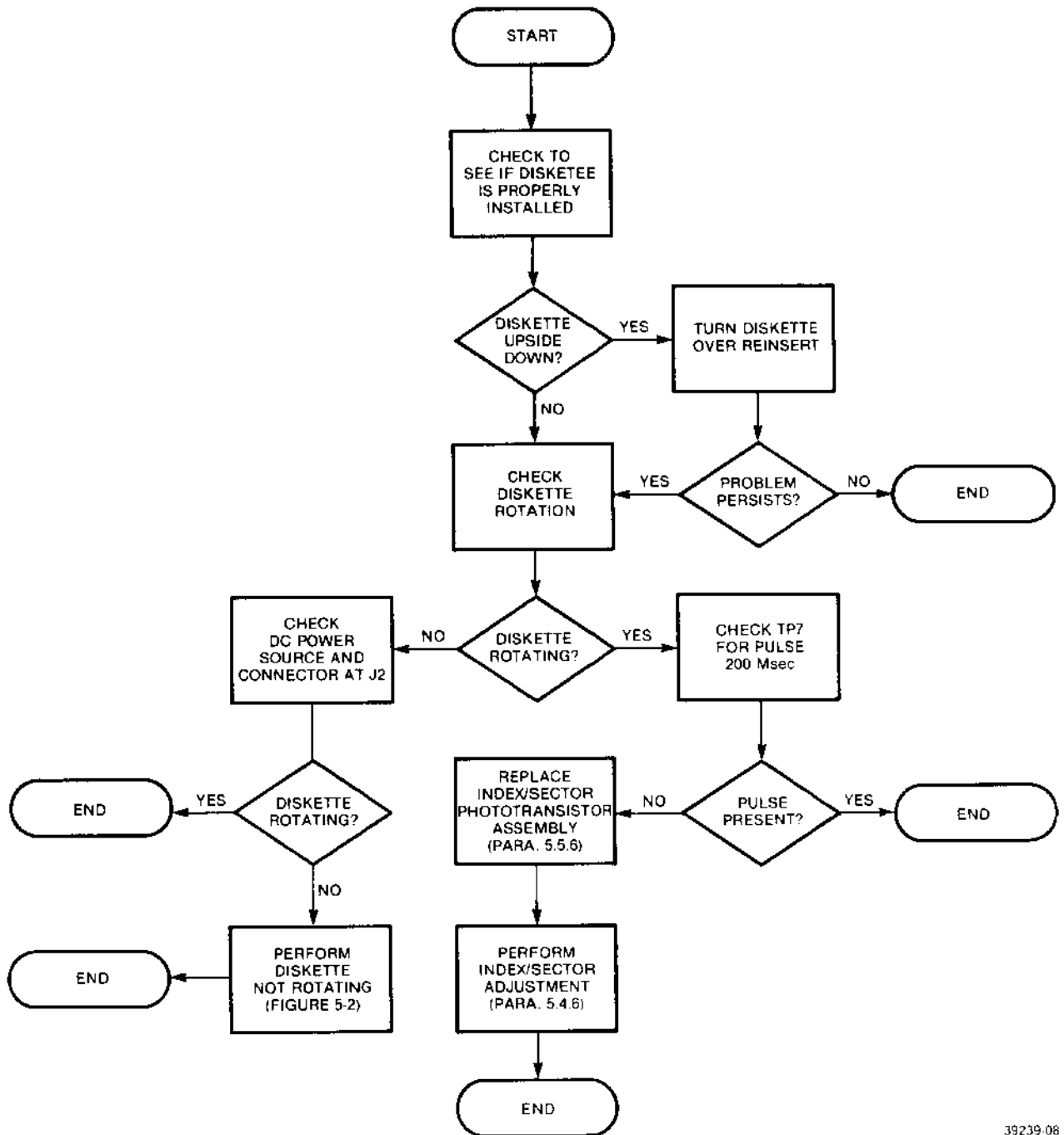

39239-08

FIGURE 5-5. INDEX PULSE INOPERATIVE

5.4 ADJUSTMENTS

5.4.1 Head Radial Alignment

NOTE

The SA465 read/write head assembly is aligned at factory and adjustment of head to head alignment is not field adjustable.

- a. Insert alignment diskette (SA455 = SA128) (SA465 = 126).

NOTE

Alignment diskette should be at room conditions for at least 24 hours before alignment checks.

- b. Select drive and step head(s) to track ³²16 (SA455) or track 64 (SA465).
- c. Sync oscilloscope external negative on TP7 (—INDEX). Set time base to 20 msec per division. This will display over one revolution.
- d. Connect one probe to TP1 and other to TP2. Ground probes to PCB. Set inputs to ac, ADD, and invert one channel. Set vertical deflection to 50 mV/division.
- e. Amplitude of two lobes must be within 70% of each other (80% for 465). If lobes do not fall within specification, continue on with procedure (see figure 5-6).

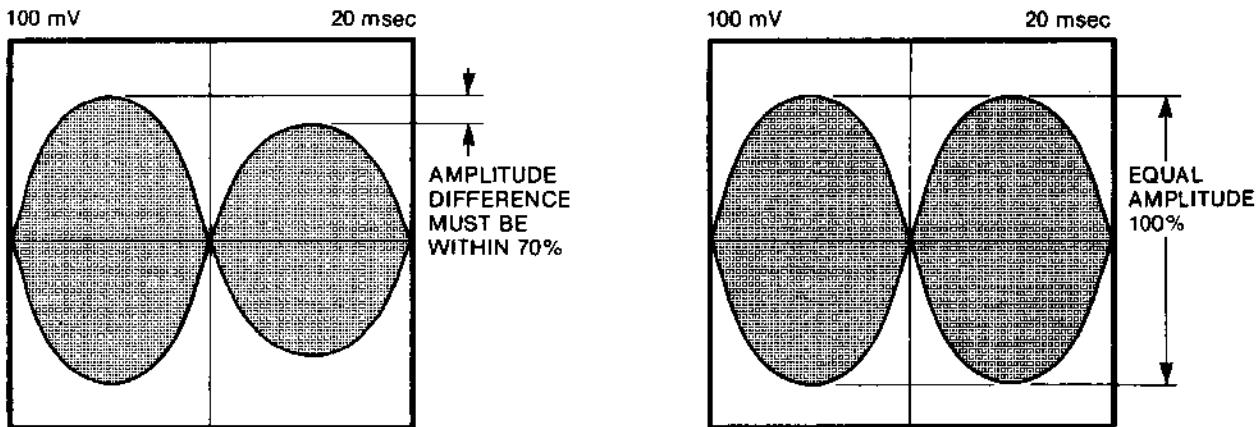

FIGURE 5-6. ALIGNMENT LOBES

39239-25

- f. Loosen two mounting screws, which hold stepper motor to base casting (see figure 5-7).
- g. Adjust stepper motor.
- h. When lobes are of equal amplitude, tighten motor plate mounting screws (see figure 5-7).
- i. Check adjustment by stepping off track and returning. Check in both directions and readjust as required.
- j. Whenever head radial alignment has been adjusted, track 00 detector must be checked (paragraph 5.4.4).

CAUTION

When tightening mounting screws, pressure **must** be applied to the rear of the step motor through the rectangular hole in the side of the casting to keep the motor bracket against the registering surfaces of the casting. Failure to do this will angle the band positioner causing track-to-track problems.

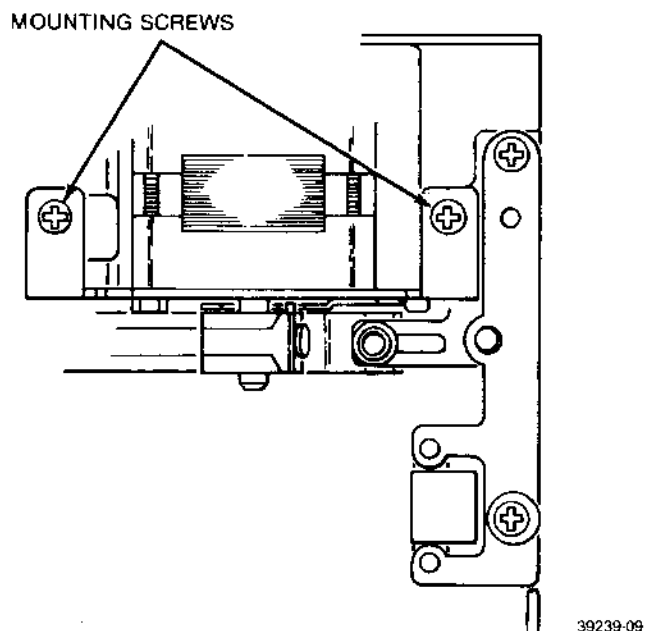

FIGURE 5-7. STEPPER MOTOR MOUNTING SCREWS

5.4.2 Read/Write Head(s) Azimuth Check

The azimuth is not field adjustable. If after performing this check the waveform on the oscilloscope is not within ± 21 minutes, replace the read/write head(s) assembly.

- Install alignment diskette (SA455 = SA128) (SA465 = SA126).
- Select drive and step to track 33 (SA455) or track 64 (SA465).
- Sync oscilloscope external negative on TP7. set time base to 0.5 msec per division.
- Connect one probe to TP1 and other to TP2. Invert one channel and ground probes to PCB. Set inputs to ac. ADD. and 50 mV per division.
- Compare waveform to figure 5-8. If not within range shown, replace read/write head assembly.

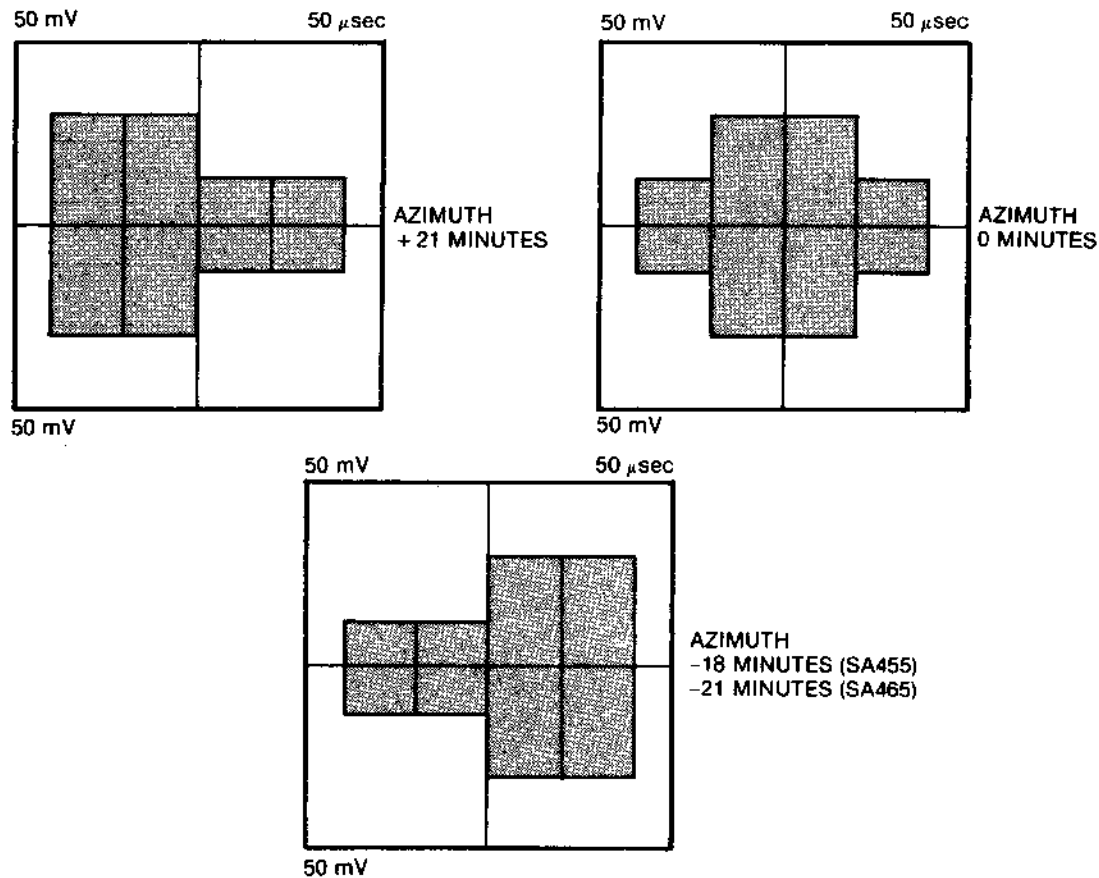

FIGURE 5-8. AZIMUTH CHECK

39239-10

5.4.3 Head Amplitude Check

These checks are only valid when writing and reading back as described below. Ensure the diskette used for this check is not “worn” or otherwise shows evidence of damage on either side.

- a. Install good media.
- b. Start motor.
- c. Select drive and step to track 39 (SA455) or track 79 (SA465).
- d. Sync oscilloscope external on TP7 (+Index); connect one probe to TP2 and TP1 on drive PCB. Ground probes to PCB, ADD, and invert one input. Set volts per division to 50 mV and time base to 20 msec per division.
- e. Select head 0 and write a 2F pattern on entire track. Average minimum amplitude peak-to-peak should be 100 mV.
- f. Select head 1 and write a 2F pattern on entire track. Average minimum amplitude peak-to-peak should be 100 mV.
- g. If either head fails to meet minimum amplitude specifications, continue with procedure.
- h. Install fresh media and recheck.
- i. Check motor speed as per paragraph 5.4.6.
- j. With oscilloscope in “chop” mode, verify that output exists at both TP1 and TP2. If one TP has no output, or significantly less output than other, turn head cable connector over at J4. Should same TP have little or no output, PCB is faulty and needs replacing. If opposite TP now exhibits problem, head assembly is at fault, and should be replaced. Refer to paragraph 5.5.3.

5.4.4 Track Zero Detector Assembly Adjustment

- a. Apply power to drive and install alignment diskette SA128 or SA126.
- b. Select drive and step to track 00.
- c. Sync oscilloscope external negative on TP7 (—Index). Set time base to 20 msec per division.
- d. Connect one probe to TP1 and other to TP2. Ground probes to PCB. Set input to ac, ADD, and invert one channel. Set vertical deflection to 100 mV/division.
- e. The 125 k Hz signal recorded should be observed at this time.
- f. If 125 k Hz signal is not present, step forward one track at a time and verify 125 k Hz signal is present. Step only five tracks.
- g. Step back towards track 00 detector and verify presence of 125 k Hz signal. Repeat stepping until signal is found.
- h. Once 125 k Hz signal is present on oscilloscope, carriage is located at track 00. Disconnect probes from TP1, TP2, and TP7. Connect one channel to TP8 and set input to dc. Set vertical deflection to 2 V per division. Trigger oscilloscope on selected input channel.
- i. Step to track 01 and verify that TP8 goes to zero.
- j. If not, loosen track 00 bracket.
- k. Set drive to seek alternately between tracks 00 and 01.
- l. Adjust eccentric until a 50% duty cycle is obtained (see figure 5-9).
- m. Tighten track 00 bracket and recheck timing.
- n. If same signal is obtained, remove alignment diskette, power down drive, and reinstall PCB. If same signal is not obtained, repeat steps k-n.

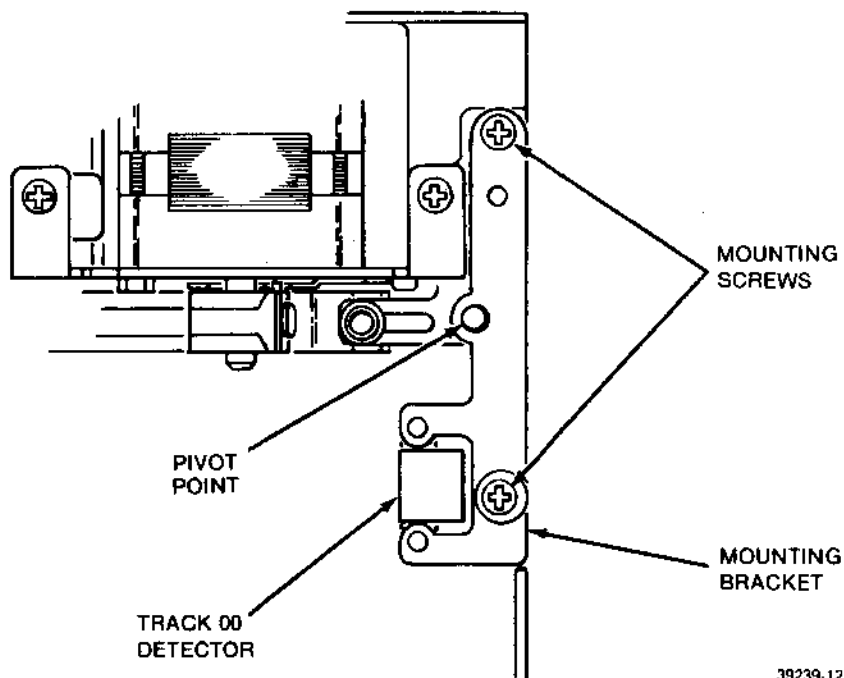

FIGURE 5-9. TRACK ZERO ADJUSTMENT

5.4.5 Index/Sector Timing Adjustment

- a. Insert alignment diskette SA128 or SA126.
- b. Start motor and select head 0.
- c. Step carriage to track 01 (SA455) or track 02 (SA465).
- d. Sync oscilloscope external positive on TP7 (+Index). Set time base to $50 \mu\text{sec}/\text{division}$.
- e. Connect one probe to TP1 and other to TP2. Ground probes to PCB. Set inputs to ac, ADD, and invert one channel. Set vertical deflection to $500 \text{ mV}/\text{division}$.
- f. Observe timing between start of sweep and first data pulse. This should be $200 + 200/-100 \mu\text{sec}$. If timing is not within tolerance, continue on with adjustment. See figure 5-10.
- g. Loosen mounting screw in index detector block until assembly is just able to be moved. See figure 5-11.
- h. Step carriage to track 38 (SA455) or track 76 (SA465).
- i. Observing timing, adjust detector until timing is $200 + 200/-100 \mu\text{sec}$. Ensure that detector assembly is against registration surface on hub frame.
- j. Tighten mounting screw.
- k. Step carriage to track 01 (SA455) or track 02 (SA465).
- l. Recheck timing.
- m. Repeat for head 1.

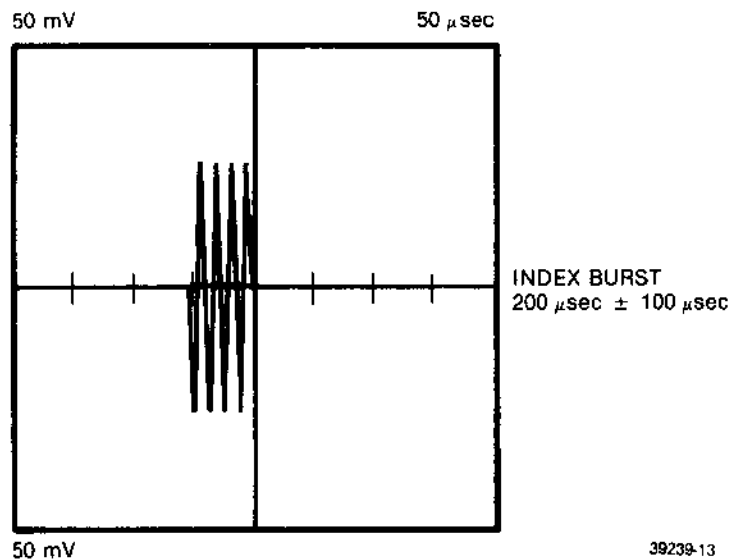

FIGURE 5-10. INDEX BURST

39239-13

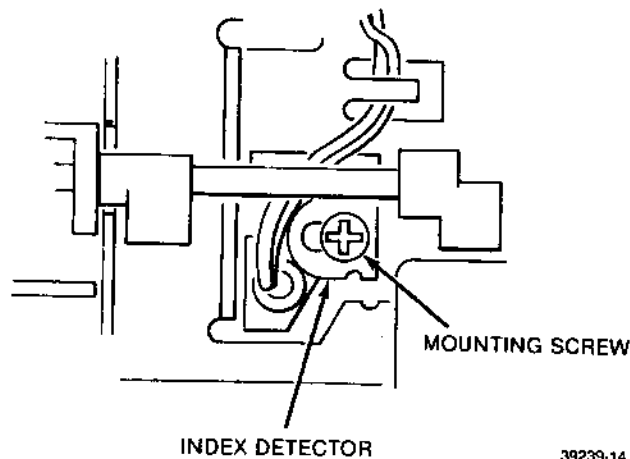

FIGURE 5-11. INDEX DETECTOR

5.4.6 Motor Speed Adjustment (Using a Frequency Counter)

This adjustment is not recommended for the field.

- a. Install SA128/126 or SA154/155 diskette; start motor and step to track 32.
- b. Connect frequency counter to TP7 (+Index) on drive PCB.
- c. Adjust pot located on the motor PCB for 5 ± 0.05 Hz (Period = 200 ± 2 ms).

5.4.7 Write Protect Detector

- a. Insert diskette into drive. Write protect notch must be open.
- b. Set oscilloscope to AUTO SWEEP, 2 V/div. Monitor TP9.
- c. Check to see if logic level changes when diskette is removed.

5.4.8 Test Points On Drive PCB

Test points for the drive PCB are as follows:

1	+Read Data	9	Write Protect
2	-Read Data	10	Ground
5	Signal Ground	12	Step Pulse
6	Digital Read Data	13	Motor On
7	Index	15	Ground
8	Track 00		

See figure 5-12 for test point locations.

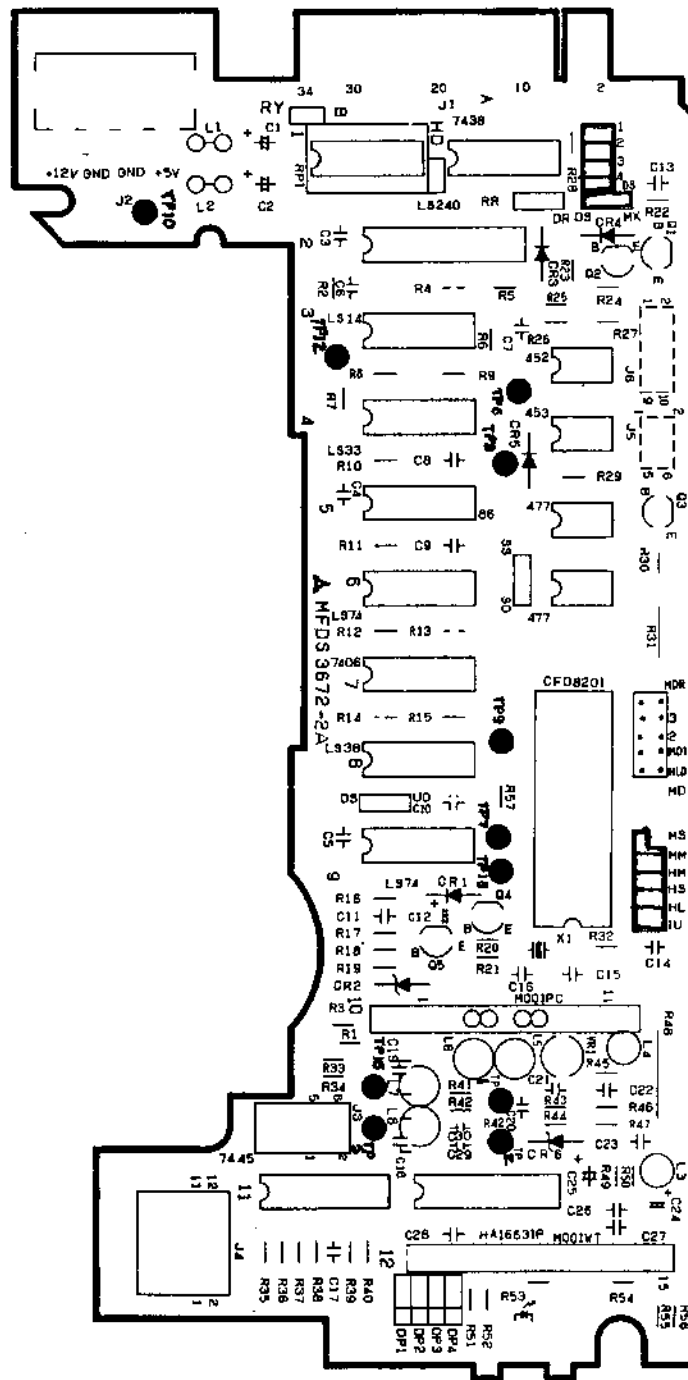

39239-1B

FIGURE 5-12. PCB COMPONENT LOCATIONS, P/N'S 25284 AND 25286

5.5 REMOVALS AND REPLACEMENTS

5.5.1 Faceplate Latch

- a. Open door. Remove door latch.
- b. Remove mounting screw on each side of faceplate. Pull faceplate forward and away from drive casting.
- c. No re-adjustment is required after replacement.

5.5.2 Direct Drive Motor Assembly

This assembly is not recommended for field replacement.

5.5.3 Head and Carriage Assembly

This assembly is not recommended for field replacement.

5.5.4 Stepper Motor and Actuator Assembly

This assembly is not recommended for field replacement.

5.5.5 Clamp Hub

- a. Remove PCB.
- b. Open door.
- c. Remove clamp assembly front and rear screws.
- d. To reinstall: Position hub clamp with spacer and spring in place onto spindle hub. (Large end of spring is placed against hub frame.)
- e. Press hub frame down towards spindle until hub shaft protrudes through mounting hole in hub frame.
- f. Reinstall faceplate. Readjustment is not required.

5.5.6 Write Protect Sensor and Index Detector

- a. Remove connector from PCB.
- b. Remove mounting screw from write protect assembly. This will free assembly.
- c. Remove index detector screw to free detector.
- d. Reverse instructions to reinstall.

5.5.7 Track Zero Photo Detector

- a. Remove PCB and shields from drive.
- b. Remove: white wire from J6 Pin 2.
green wire from J6 Pin 1.
yellow wire from J6 Pin 10.
- c. Loosen mounting bracket screws.
- d. Remove two screws securing LED housing to track 00 plate.
- e. To reinstall, reverse above procedure.
- f. Adjust as directed in paragraph 5.4.5.

5.6 RECOMMENDED INCOMING RECEIVING INSPECTION

5.6.1 Necessary Equipment

All Shugart drives are 100% adjusted and tested before leaving the factory. It is only necessary to inspect for shipping damage on receipt of drives.

Inspection should be simple and test equipment kept to a minimum. Shugart recommends the following equipment.

- a. SA809 Exerciser (P/N 54157)
- b. Exerciser Instruction Manual (P/N 50686)
- c. Power Supply for Exerciser and Drive (+5, +12 V)
- d. Oscilloscope
- e. SA128/126 Alignment Diskette
- f. SA455/465 Service Manual (P/N 39239-0)

5.6.2 Procedure

- a. Unpack drive and inspect for physical shipping damage.
- b. Make sure all power is off.
- c. Attach exerciser cables to appropriate drive connectors.
- d. Power up.
- e. Insert alignment diskette (SA455 = SA128, SA465 = SA126).
- f. Set track addresses of 00 and 39 (SA455) or 79 (SA465) into exerciser.
- g. Select drive.
- h. Start motor and let drive seek automatically for 5 minutes.
- i. Check that activity light is on.
- j. Using this SA455/465 Service Manual and the Exerciser Instruction Manual as guides, perform the following checks:
 - Index Timing Adjustment (paragraph 5.4.6).
 - Head Radial Alignment, Sides 0 and 1 (paragraph 5.4.1).
 - Track Zero Switch is on at track 00 and off at 01 and 02.
- k. Remove alignment diskette and insert SA154/155 diskette.
- l. Seek to track 39 (SA455) or track 79 (SA465) and write a 2F signal. Minimum read back should be 90 mV.
- m. Check write protect sensor adjustment (paragraph 5.4.8).
- n. Power off.
- o. Remove connectors and repack drive.

This procedure verifies that the critical functions of the drive are working properly (i.e., the drive will read and write, the disk will rotate at the proper speed, and critical adjustments are within specification).

SECTION VI SCHEMATIC DIAGRAMS

The following schematic diagram is furnished as an aid to malfunction analysis of PCB's 25284 (SA455) and 25286 (SA465).

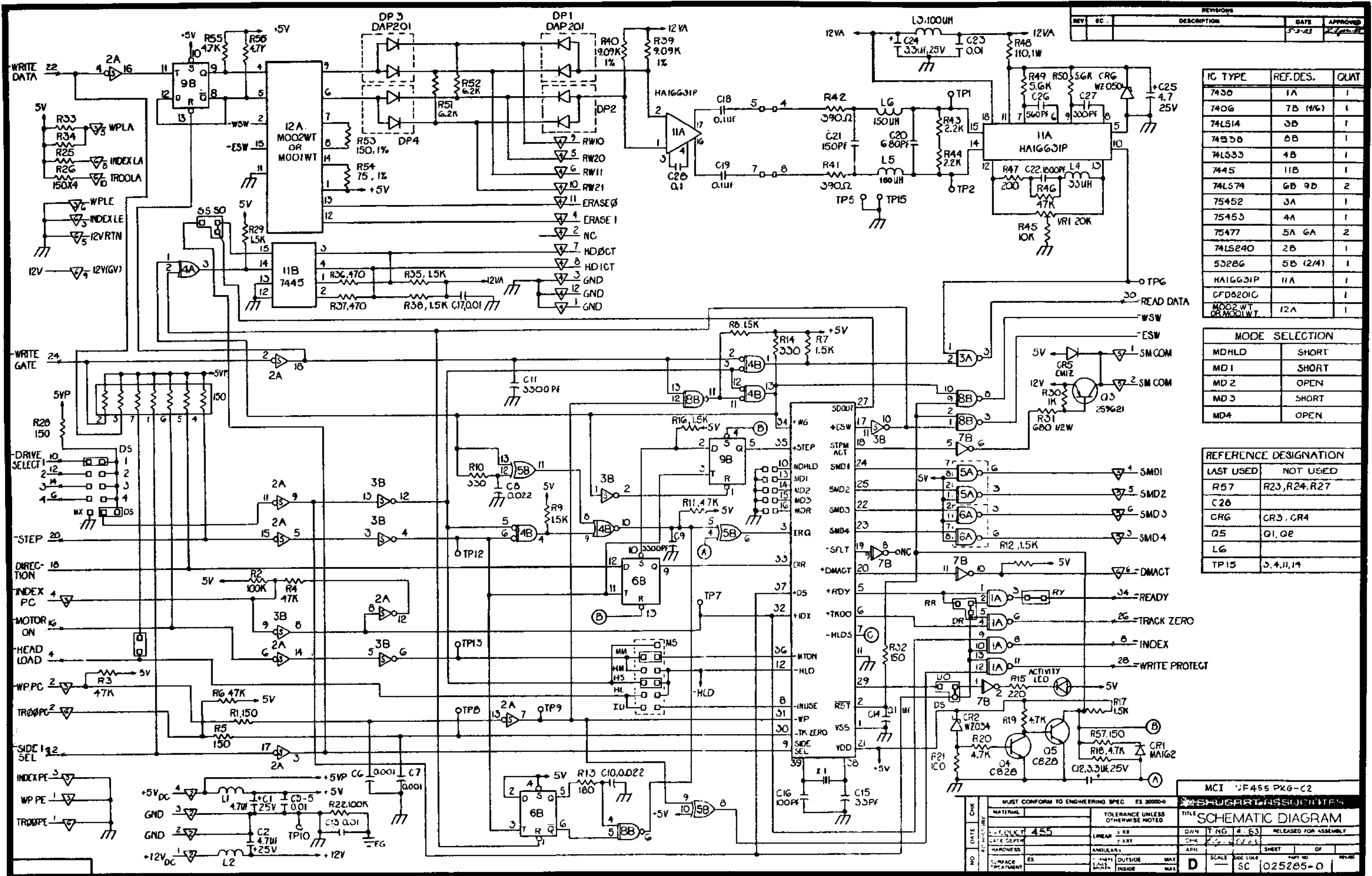

FIGURE 6-1. SCHEMATIC DIAGRAM, P/N 25284

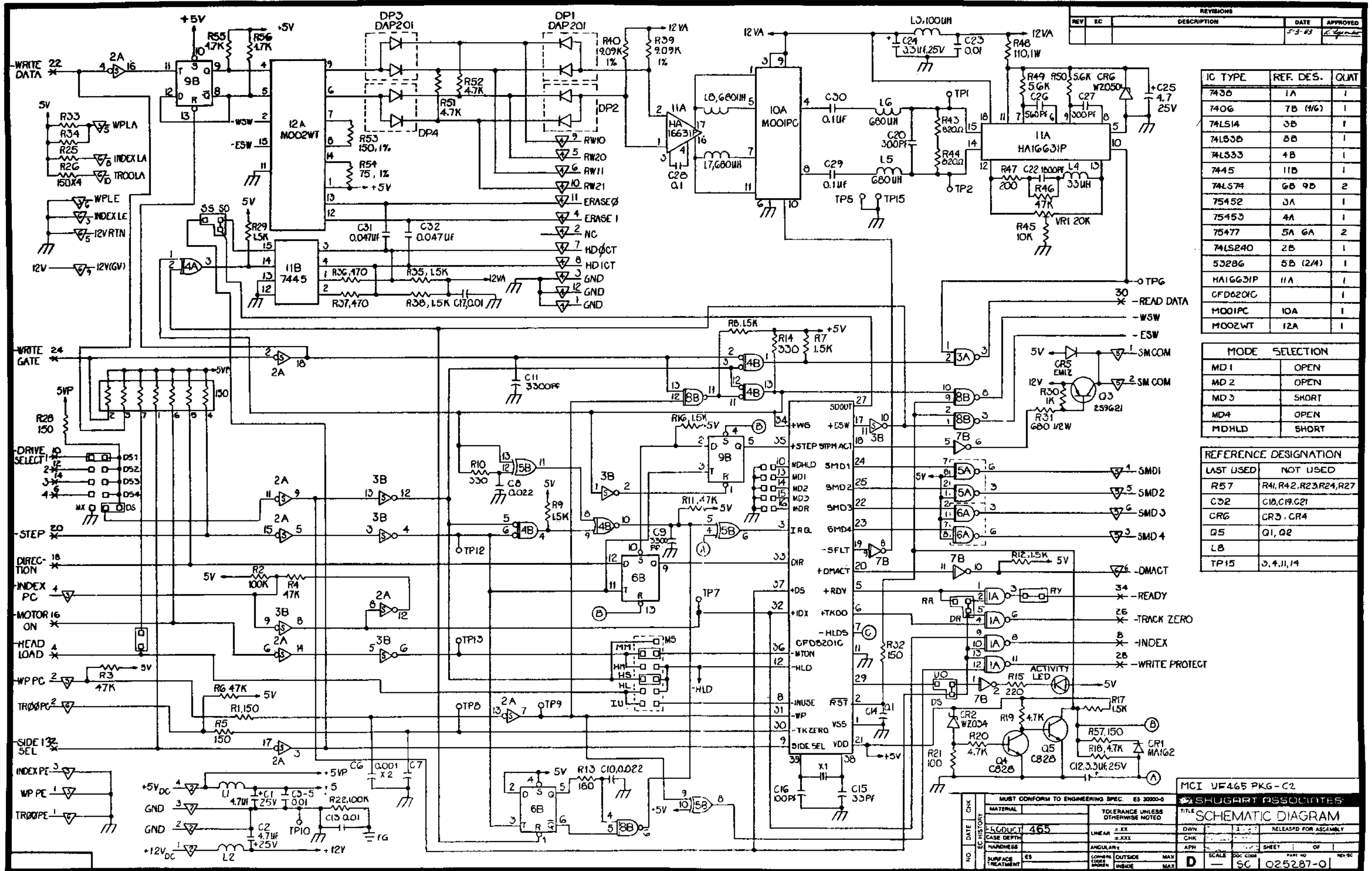

FIGURE 6-2. SCHEMATIC DIAGRAM, P/N 25286

SECTION VII ILLUSTRATED PARTS CATALOG

7.1 DESCRIPTION

The Illustrated Parts Catalog (IPC) is arranged so that the figure will always precede the parts listing and, when possible, will appear directly above the parts list or on the left hand page immediately preceding it.

The first number in the list will always refer to the figure number. The second number will refer to the reference number of the part within the figure.

Part numbers enclosed in parentheses refer to parts belonging to a Next Higher Assembly (NHA) and are of importance only to those customers with alternate assemblies. Following the descriptions of these parts, the designation NHA P/N _____ gives the part number of the assembly to which they pertain. When applicable to the customer's assembly, these alternate parts will be used in lieu of the part listed directly above them. Assume that the quantity per assembly for these alternate parts is the same unless otherwise listed.

When an assembly is referred to within a figure and a further breakdown is shown on another figure, then the referenced figure will be called out.

7.2 QUANTITY PER ASSEMBLY

The quantity listed is the quantity used on the major assembly. Major assemblies themselves will not have a quantity listed.

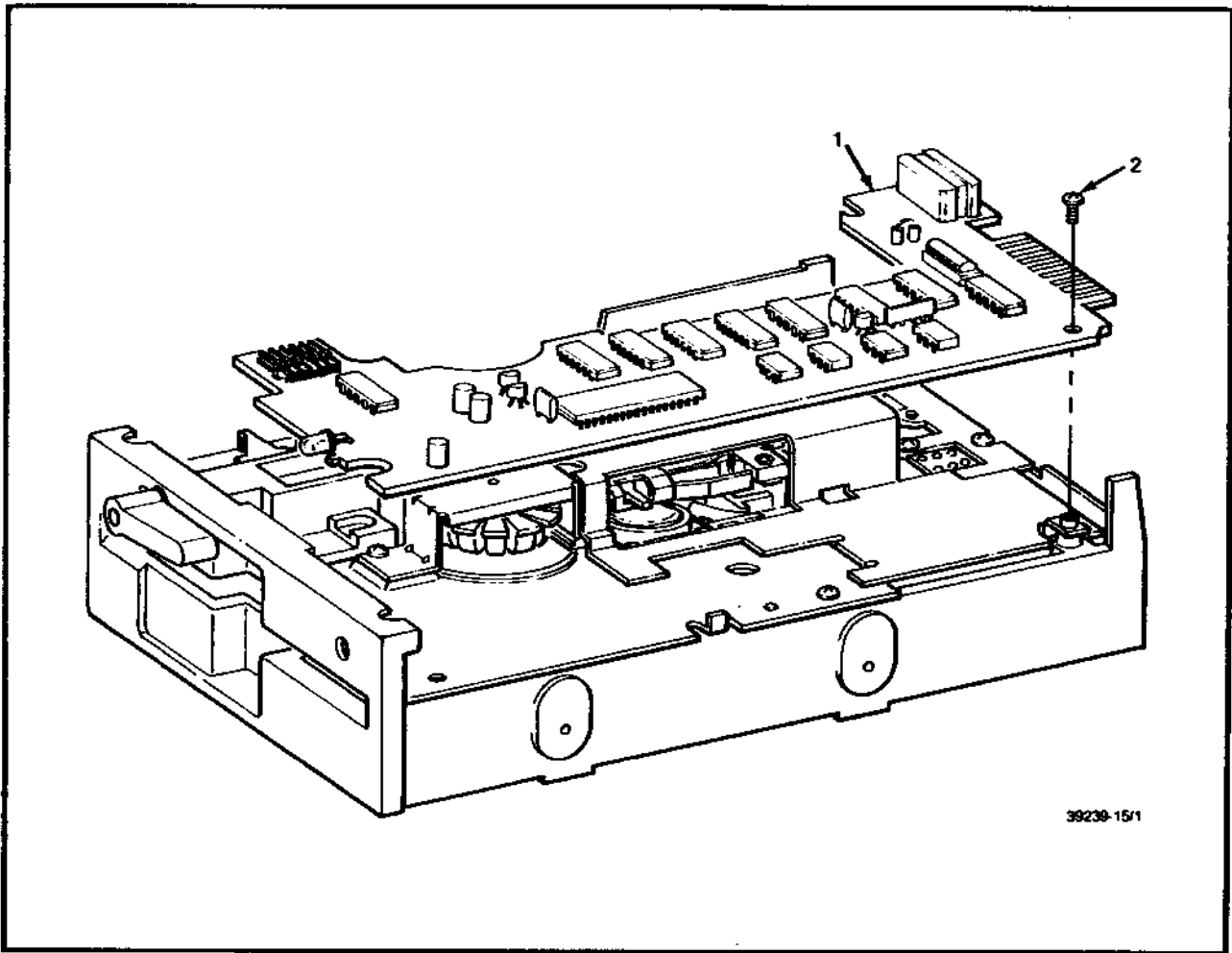

39238-15/1

FIGURE 7-1. SA455/465 BASIC DRIVE ASSEMBLY (SHEET 1 OF 4)

SA455/465 BASIC DRIVE ASSEMBLY

REFERENCE NUMBER	PART NUMBER	DESCRIPTION	QTY
Ref	51756	SA455/465 MINIFLOPPY™ DRIVE	
1	25284	SA455 PCB	1
	25286	SA465 PCB	1
2	11477	SCREW	2

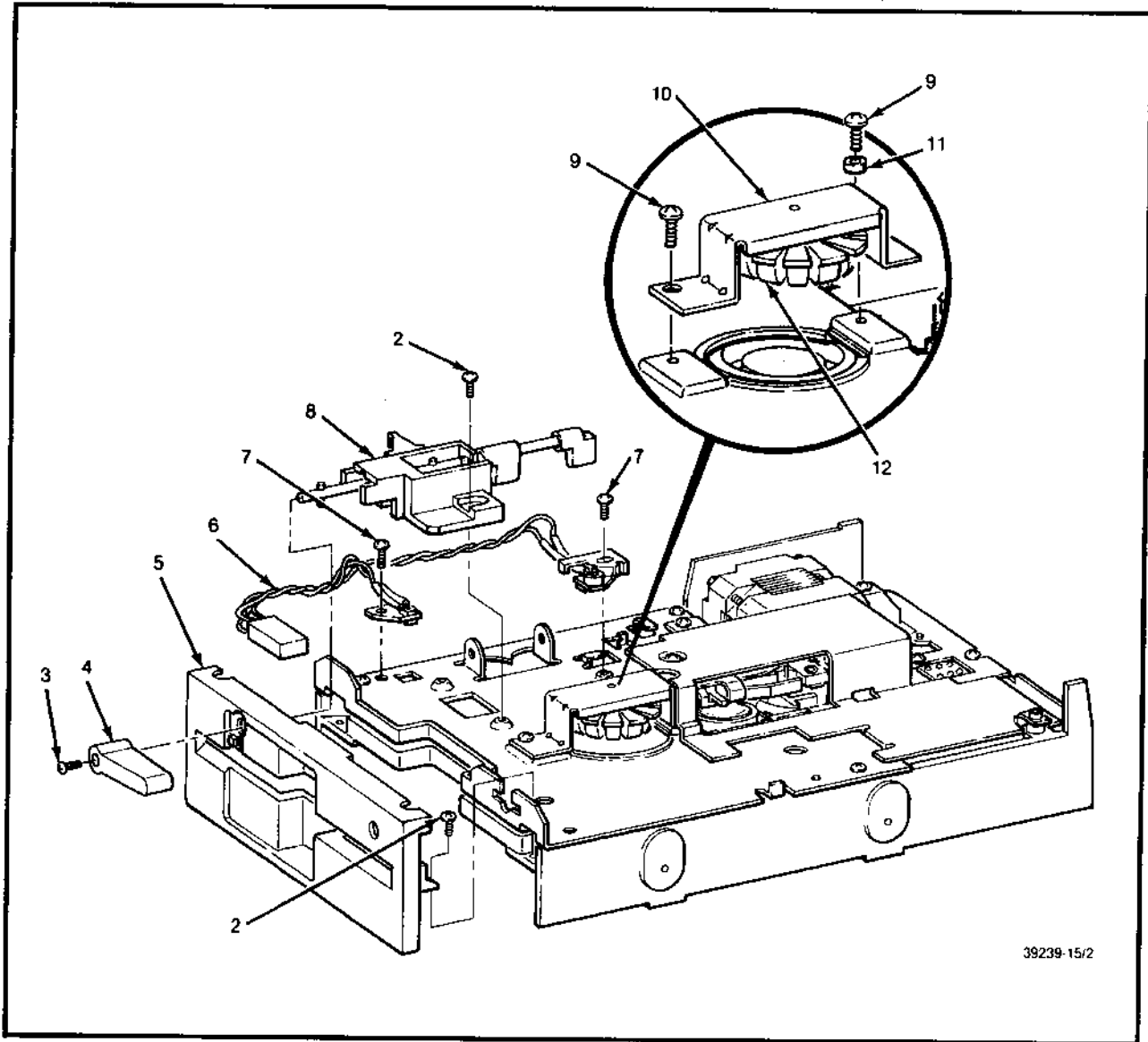
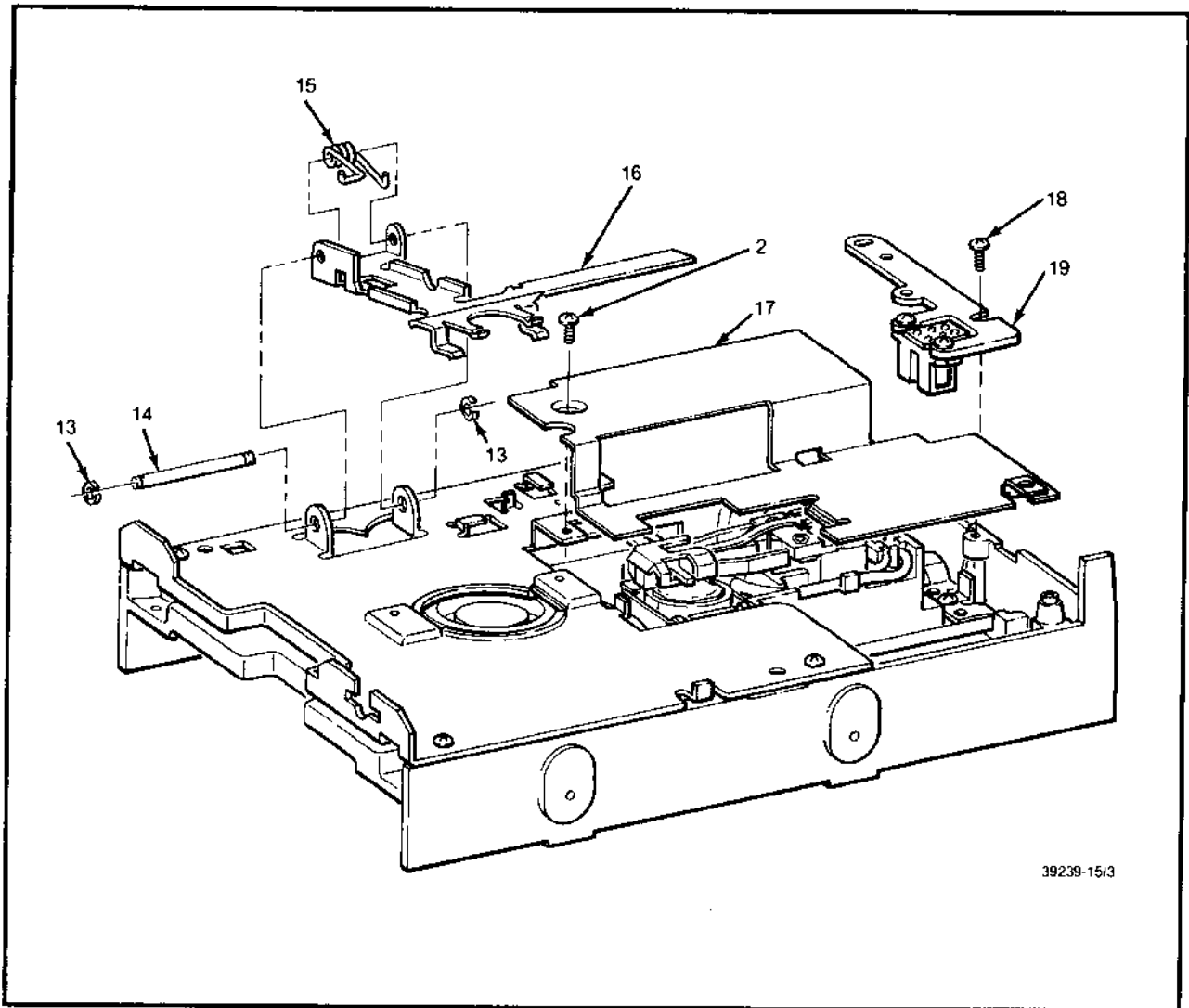

FIGURE 7-1. SA455/465 BASIC DRIVE ASSEMBLY (SHEET 2 OF 4)

SA455/465 BASIC DRIVE ASSEMBLY (CONT.)

REFERENCE NUMBER	PART NUMBER	DESCRIPTION	QTY
3	11464	SCREW	1
4	51782	CLAMP HANDLE	1
5	52446	FACE PLATE	1
6	54758	WRITE PROTECT/INDEX DETECTOR	1
7	11475	SCREW	2
8	51896	GUIDE SHAFT ASSEMBLY	1
9	11450	SCREW	2
10	51898	CLAMP CAM ASSEMBLY	
11	51788	SPACER	1
12	54765	COLLET	1



39239-15/3

FIGURE 7-1. SA455/465 BASIC DRIVE ASSEMBLY (SHEET 3 OF 4)

SA455/465 BASIC DRIVE ASSEMBLY (CONT.)

REFERENCE NUMBER	PART NUMBER	DESCRIPTION	QTY
13	11461	E-RING	2
14	51785	LIFT SHAFT	1
15	51784	LIFT SPRING	1
16	51786	LIFTER	1
17	54768	SHIELD PLATE	1
18	11468	SCREW	1
19	54762	TRACK 00 SENSOR	1

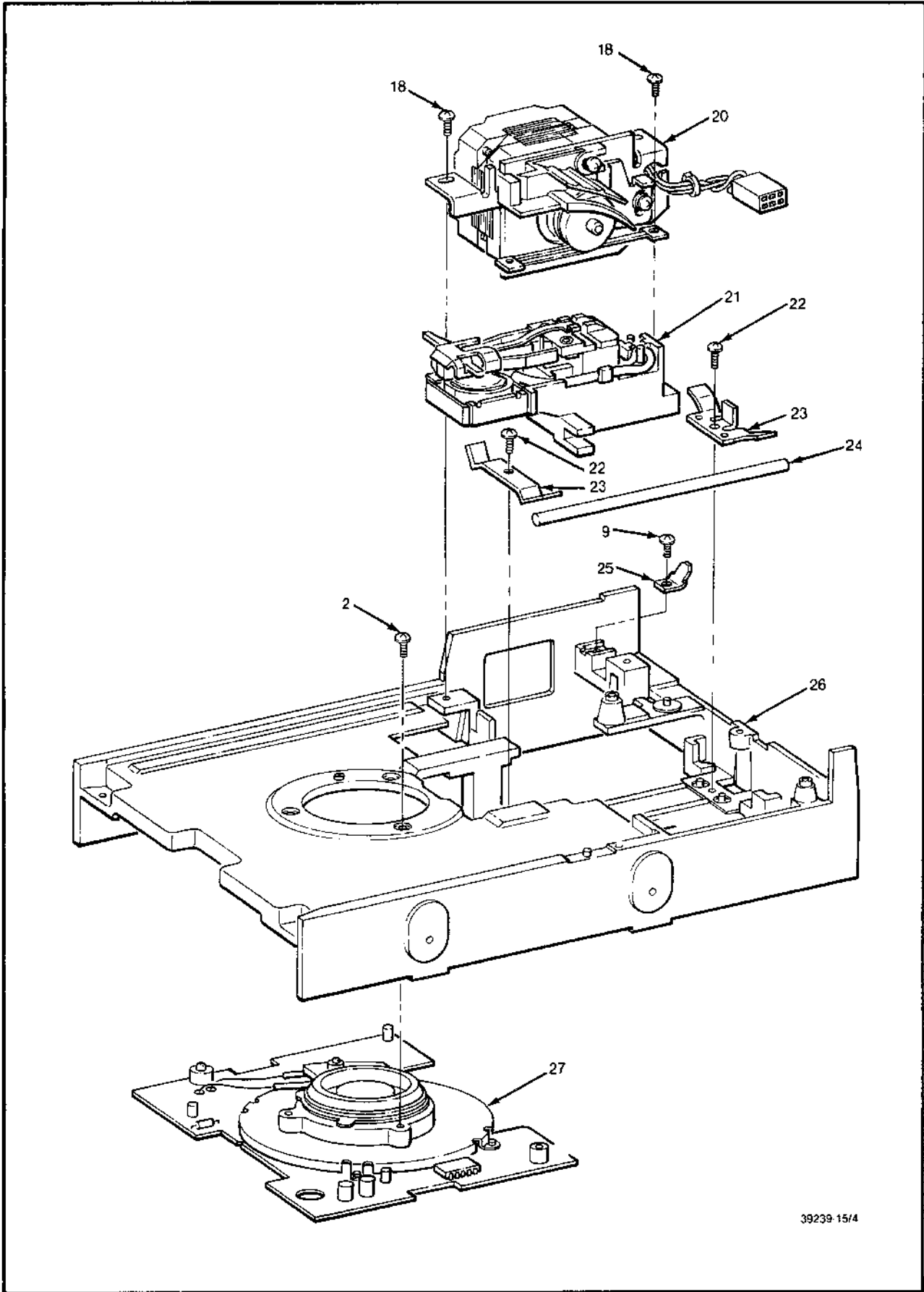

39239-15/4

FIGURE 7-1. SA455/465 BASIC DRIVE ASSEMBLY (SHEET 4 OF 4)

SA455/465 BASIC DRIVE ASSEMBLY (CONT.)

REFERENCE NUMBER	PART NUMBER	DESCRIPTION	QTY
20	51754	STEPPER ASSEMBLY	1
21	54773	SA455 HEAD CARRIAGE ASSEMBLY	1
	54814	SA465 HEAD CARRIAGE ASSEMBLY	1
22	11476	SCREW	2
23	51895	CLAMP, Guide Rod	2
24	51801	GUIDE ROD	2
25	11456	FASTEN TAB	1
26	51757	BASE	1
27	51800	DRIVE MOTOR	1

TABLE 7-1. REFERENCE NUMBER TO PART NUMBER CROSS REFERENCE

Part Number	Reference Number
11450	1-9
11456	1-32
11461	1-23
11464	1-3
11468	1-18
11475	1-7
11476	1-22
11477	1-2
25284	1-1
25284	1-2
51754	1-26
51757	1-33
51771	1-36
51782	1-4
51783	1-9
51784	1-17
51785	1-24

Part Number	Reference Number
51786	1-18
51788	1-14
51800	1-34
51801	1-30
51895	1-23
51896	1-8
51898	1-13
52446	1-5
54758	1-6
54762	1-22
54765	1-15
54768	1-20
54773	1-27
54814	1-24

39239-19

7.3 RECOMMENDED SPARE PARTS STOCKING GUIDE

The spare parts stocking guide is broken down into three levels. These levels are: Site or Field Support Engineer, Branch Office, and Depot or Headquarters. The quantities listed assume that the Site is replenished by the Branch immediately and the Branch replenished by the Depot within 30 days.

The inventories that the levels can maintain are:

Site	1 to 20 machines
Branch	1 to 100 machines
Depot	
Depot only parts	Unlimited
Branch replenishment	Same as Branch ratio

Table 7-2 shows the spare parts required to support the SA455/465 in the field.

TABLE 7-2. SA455/465 SPARE PARTS STOCKING GUIDE

PART NUMBER	DESCRIPTION	QUANTITY PER LEVEL		
		SITE	BRANCH	DEPOT
25284	PCB, SA455	1	3	4
25286	PCB, SA465	1	3	4
51781	LOCK CAM			2
51782	CLAMP HANDLE	1	4	4
51783	LOCK SPRING	1	2	2
51784	LIFTER SPRING	1	2	2
51785	LIFTER SHAFT		2	2
51896	GUIDE SHAFT ASSEMBLY			2
51899	CLAMP BEARING			2
52445	STEPPER MOTOR			2
52446	FACE PLATE		2	3
54755	FACE PLATE (FULL HEIGHT)		2	3
54758	WRITE PROTECT/INDEX DETECTOR ASSEMBLY	1	3	3
54762	TRACK 00 ASSEMBLY	1	3	3
54765	COLLET ASSEMBLY		2	2
54768	SHIELD PLATE		1	2
54770	SPINDLE MOTOR			2
54771	GUIDE ROD			2
54773	SA455 HEAD CARRIAGE		2	3
54814	SA465 HEAD CARRIAGE		2	3

**COMPONENT DESCRIPTION
OF 25270 IN PROCESS.**

Shugart Corporation
475 Oakmead Parkway
Sunnyvale, CA 94086

408 733-0100
TWX: 910-339-9355
SHUGART SUVL
