

REVISIONS				
ZONE	REV	DESCRIPTION	DATE	APPROVED

INSTRUCTION FORMAT	15	14	13	12	11	10	9	8	7	6	5	4	3	2	1	0	
INSTRUCTION FORMAT	S ₁	S ₀	C	L	ALU FCN				OPERAND								
ARITHMETIC	0	0	C	0	ALU FCN				R _{WE}	INPUT				REG ADRS			
	0	1	C	0	ALU FCN				A _{WD}	INPUT				REG ADRS			
LOGICAL	0	0	0	1	ALU FCN				R _{WE}	INPUT				REG ADRS			
	0	1	0	1	ALU FCN				OUTPUT				REG ADRS				
FLAG	0	1	1	1					S/C	FLAG DECODE							
JUMP FORMAT	S ₁	S ₀	P/P	FE	F/T	ADDRESS											
	1	1	1	1	0	ADDRESS											
JUMP INST.	1	0	0	1	0	ADDRESS											
	1	1	X	0	0	ADDRESS											
	1	X	0	0	F/T	COND CODE											

Q (ACC, INPUT) → REG
 Q (ACC, INPUT) → ACC
 R (ACC, INPUT) → REG
 R (ACC, REG) → OUTPUT
 R (ACC, CONSTANT) → ACC
 JSR - JUMP & PUSH
 RET - RETURN & POP
 JUMP
 CONDITIONAL SKIP

INPUT (LOW TRUE PULSE)

- 0 REG
- 1 SWITCHES
- 2 DRIVE STAT
- 3 ECC HI
- 4 ECC LO
- 5 DATA BUS
- 6 AUX STAT
- 7 SPARE

OUTPUT REGS (LOW TRUE PULSE)

- 0 LD ACCUMULATOR
- 1 WR ADRS MARK
- 2 LD DSR
- 3 LD CCL
- 4 LD OHR
- 5 ECC CLK
- 6 LD LED
- 7 LD RWCL
- 8 UP INC
- 9 LD BUFFER ADRS LO
- A LD BUFFER ADRS HI
- B SPARE
- C SPARE
- D SPARE
- E SPARE
- F SPARE

BYTE	BIT							
	7	6	5	4	3	2	1	0
DRV STAT	SEK IN _D COMPL	DRV RDY	TRK RDY	WR 00	ACK FLT	SEL * R	BUSY	HOST
ECC LO	E21	E20	E19	E18	E17	E16	E15	E14
ECC HI	SEL'D 3	SEL'D 2	SEL'D 1	SEL'D 0	PAR OK	ECC OK	E23	E22

ARITHMETIC DECODE

C	S ₃	S ₂	S ₁	S ₀	
1	0	0	0	0	INC (PORT A)
1	0	1	1	0	SUB
0	0	1	1	0	SBWC
1	1	0	0	1	ADD
0	1	0	0	1	ADWC
1	1	1	0	0	SHFT
0	1	1	0	0	ROT
1	1	1	1	1	DEC
0	1	1	1	1	MOVIA

R_{WE} = IF SET ENA REG WRITE
 A_{WD} = IF SET DISABLE ACC WRITE
 C = PSEUDO CARRY
 S/C = SET/CLR
 F/T = FALSE / TRUE
 P/P = PUSH/POP
 X = DON'T CARE

FLAGS (HIGH TRUE SIGNALS)

- 0 WRITE GATE
- 1 DIRECTION IN
- 2 REDUCED WRITE CURRENT
- 3 STEP
- 4 BUFFER XCVR DISABLE
- 5 SERDES LOAD/SHIFT
- 6 SERDES HOLDING REG OUTPUT DISABLE
- 7 DISABLE OUTPUT HOLDING REG
- 8 READ GATE
- 9 DISABLE HOST RCVR
- A TBUSY
- B REQUEST DATA
- C COMMAND / DATA
- D HARD/FLOPPY PLL SELECT
- E REG BANK SEL
- F ENABLE HOST XMTR

CONDITION CODES

- 0 ALU 1
- 1 3
- 2 5
- 3 T
- 4 CARRY FF
- 5 ALU = 0
- 6 BYTE RDY
- 7 ADDRESS MARK

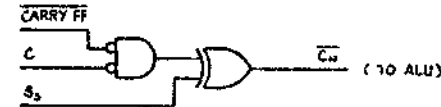

BYTE BIT

	7	6	5	4	3	2	1	0
DSR	DRV 4	DRV 3	DRV 2	DRV 1	SPARE	HD 2	HD 1	HD 0
CCL	SPARE	SPARE	INTR	TSEL	SPARE	W/R BUF	C _{MUX} 0	C _{MUX} A
R/W CL	CLR SER	CLR ECC	WR DATA	EN WR	EN RD	ECC SEL	ECC CLK	S/L ECC

* = LOW TRUE

AUG 05 1986

QTY REQD	FRM NO.	PART OR IDENTIFYING NO.	NOMENCLATURE OR DESCRIPTION	MATERIAL SPECIFICATION
PARTS LIST				
UNLESS OTHERWISE SPECIFIED DIMENSIONS ARE IN INCHES TOLERANCES ARE: FRACTIONS DECIMALS ANGLES			CONTRACT NO. 1403	DTC Data Technology Corporation
MATERIAL			APPROVALS	DATE
FINISH			DRAWN C. THEIN	9-22-89
NEXT ASSY			CHECKED	
USED OR			ISSUED	
APPLICATION			SCALE	
DO NOT SCALE DRAWING			SIZE	
			PCOM NO. D	
			DRG. NO. 01000-00010	REV.
			SCALE	SHEET 1 OF 1

AC-00030 1

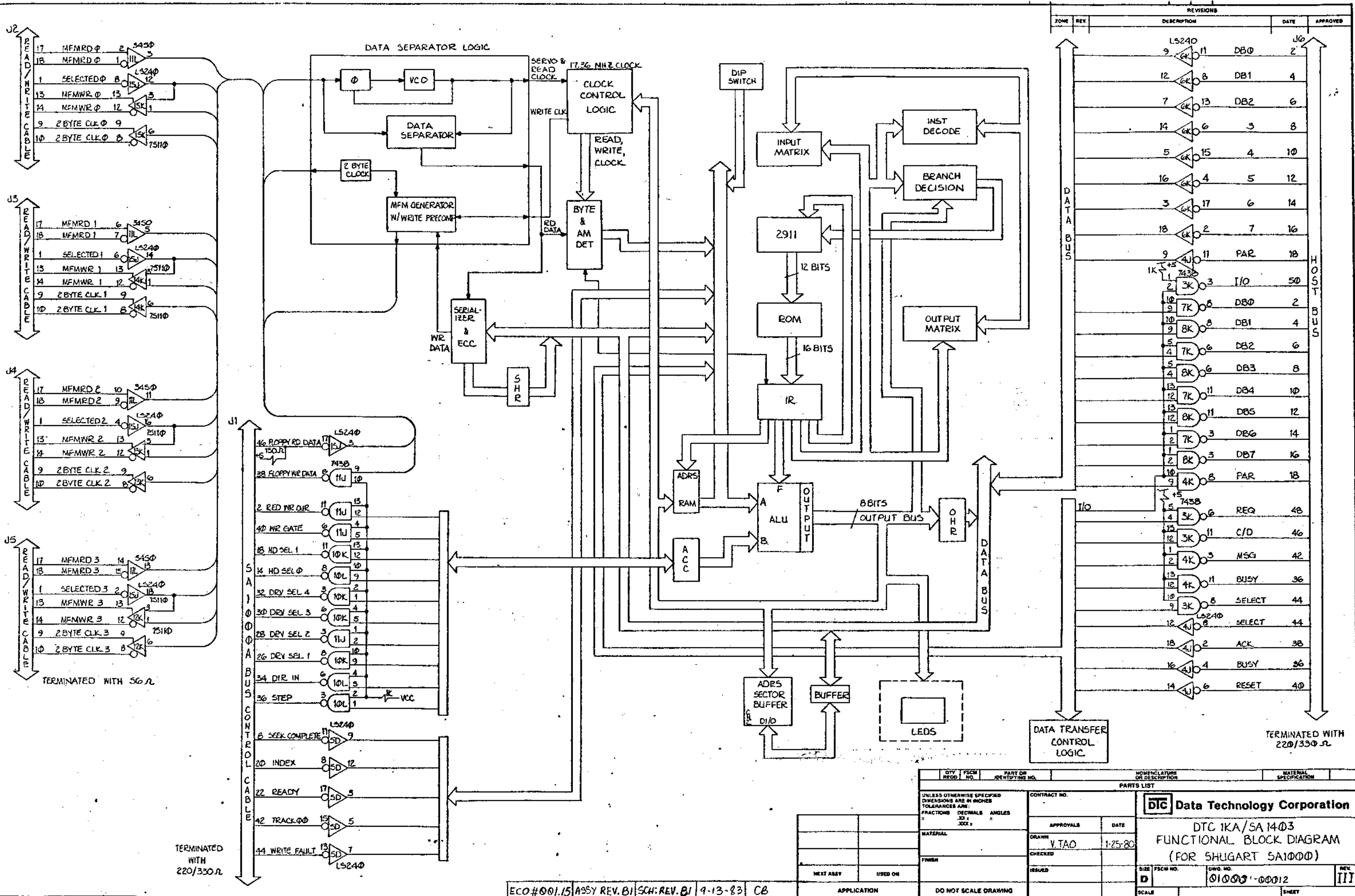

REVISIONS				
ZONE	REV	DESCRIPTION	DATE	APPROVED

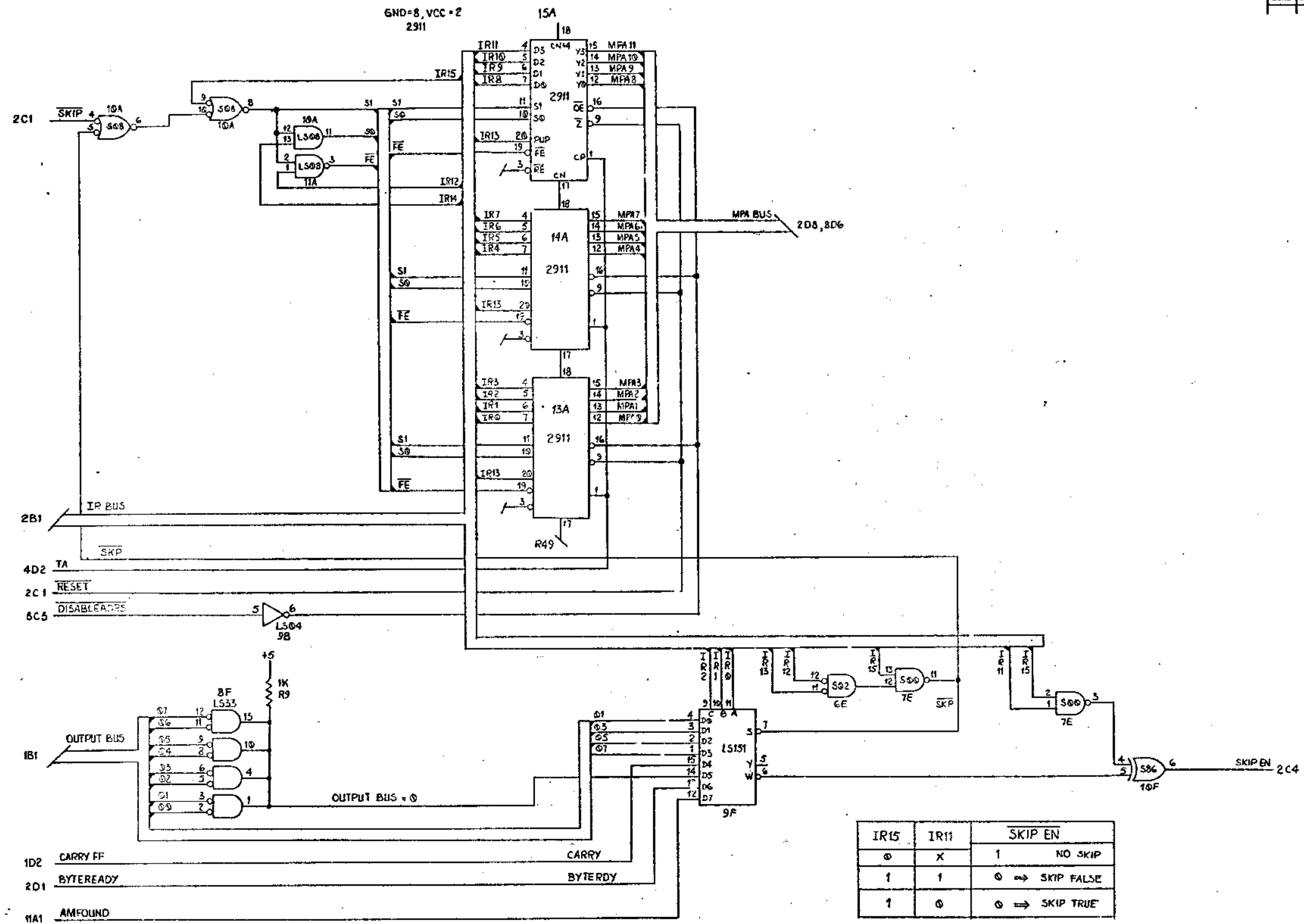

QTY	FROM	PART OR IDENTIFYING NO.	NOMENCLATURE OR DESCRIPTION	MATERIAL SPECIFICATION

UNLESS OTHERWISE SPECIFIED DIMENSIONS ARE IN INCHES TOLERANCES ARE: FRACTIONS DECIMALS ANGLES XX ± .001 ±		CONTRACT NO. SA 1403	 SA 1403 CONTROLLER ADDRESS REG & SKIP DECODE
APPROVALS	DATE	DRAWN L TSENG 8-18-80	
CHECKED		ISSUED	SIZE D FICH NO.
			DWG. NO. 01000-00006 SCALE
			SHEET 3 OF 15

REVISIONS				
EDWH	REV	DESCRIPTION	DATE	APPROVED

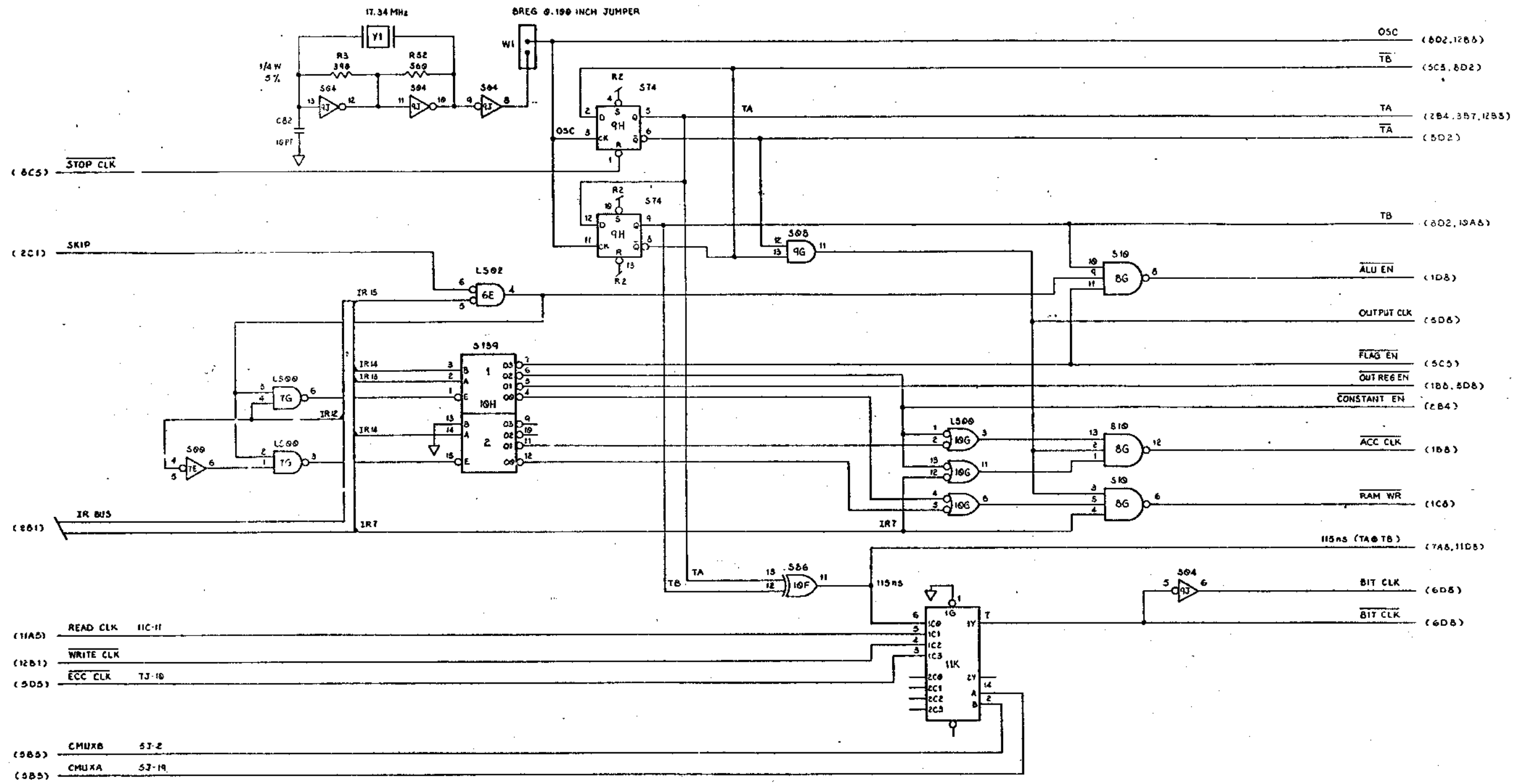

- (8C5) STOP CLK
- (2C1) SKIP
- (8B1) IR BUS
- (11A5) READ CLK IIC-11
- (12B1) WRITE CLK
- (5D5) ECC CLK TJ-10
- (5B5) CMUXB 57-2
- (5B5) CMUXA 57-19

- OSC (802,12B5)
- TB (5C5,8D2)
- TA (2B4,3B7,12B3)
- TA (5D2)
- TB (802,19A5)
- ALU EN (1D8)
- OUTPUT CLK (5D6)
- FLAG EN (5C5)
- OUT REG EN (1B5,5D8)
- CONSTANT EN (2B4)
- ACC CLK (1B8)
- RAM WR (1C6)
- I15RS (TA@TB) (7A5,11D5)
- BIT CLK (6D5)
- BIT CLK (6D8)

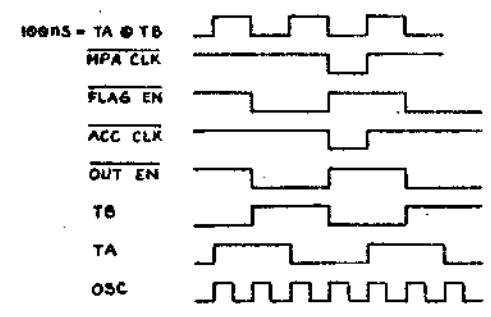

QTY	PSCH	PART OR	NOMENCLATURE	MATERIAL
REQD	NO.	IDENTIFYING NO.	OR DESCRIPTION	SPECIFICATION
PARTS LIST				
UNLESS OTHERWISE SPECIFIED DIMENSIONS ARE IN INCHES TOLERANCES ARE: FRACTIONS DECIMALS ANGLES .XX = .00XX °				
CONTRACT NO. SA 1403		DTC Data Technology Corporation		
APPROVALS	DATE	SA 1403 CONTROLLER		
DRAWN C. THEIN	9-11-80	TO, TI, CLOCKS & DECODE (INST)		
CHECKED				
ISSUED				
REV. NO. D	PSCH. NO.	DWG. NO. 01000-00000	REV. B1	
SCALE		SHEET 4 OF 15		

REVISIONS				
ZONE	REV	DESCRIPTION	DATE	APPROVED

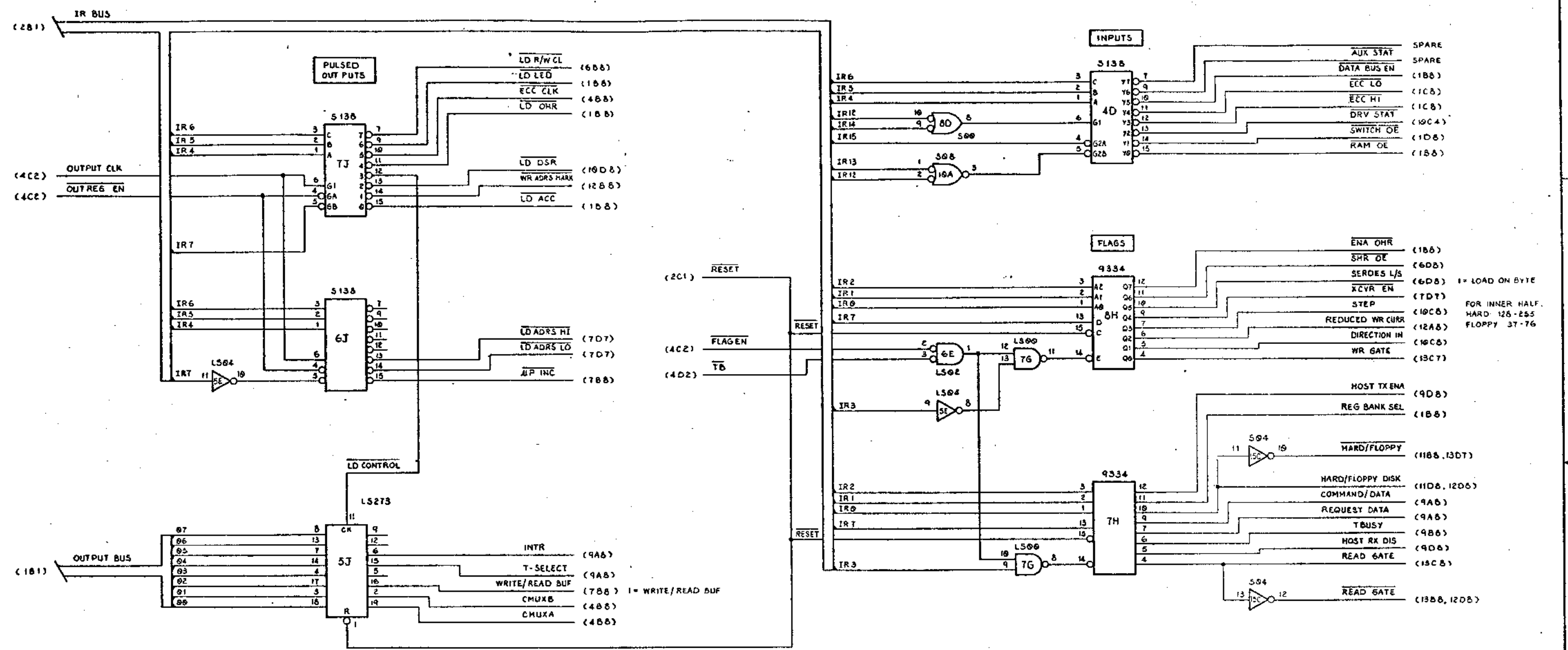

QTY	FRGM	PART OR	NOMENCLATURE	MATERIAL
REQD	NO.	IDENTIFYING NO.	OR DESCRIPTION	SPECIFICATION
PARTS LIST				
UNLESS OTHERWISE SPECIFIED DIMENSIONS ARE IN INCHES TOLERANCES ARE:		CONTRACT NO. SA 1403		
FRACTIONS DECIMALS ANGLES		APPROVALS DATE		
.XX ± .XX ±		DRAWN C. THEIN 9/11/80		
.XXX ±		CHECKED		
MATERIAL		ISSUED		
FINISH		SIZE FRGM NO. DWG. NO. REV		
NEXT ASSY		D		01000-00006 B1
USED ON		SCALE		SHEET 5 OF 13
APPLICATION		DO NOT SCALE DRAWING		

DTIC Data Technology Corporation

SA 1403 CONTROLLER
OUTPUTS, FLAGS, INPUT & CONTROL LATCH

REVISIONS				
ZONE	REV.	DESCRIPTION	DATE	APPROVED

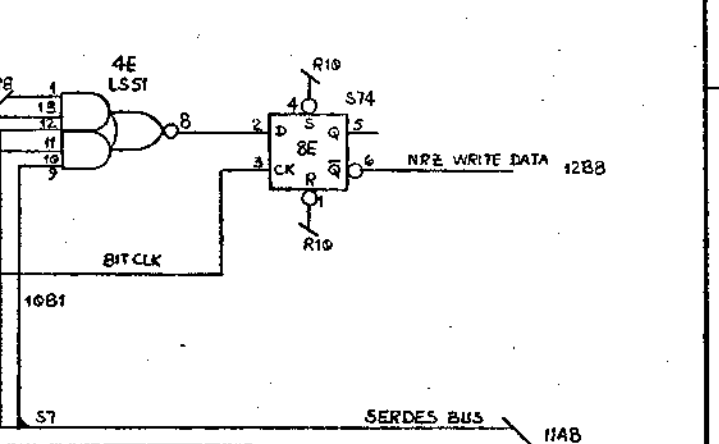

BYRDY	2D4
LD SHR	7B5
Td (LS195A)	26ns
Tsu (LS374)	23ns

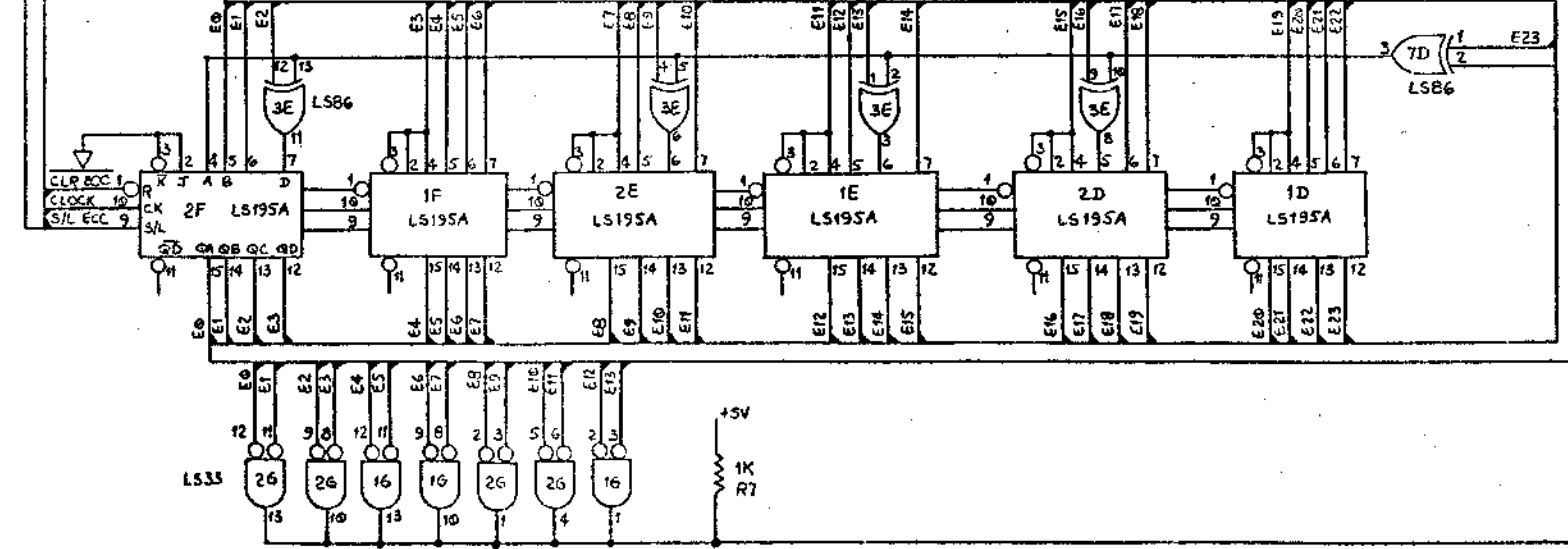
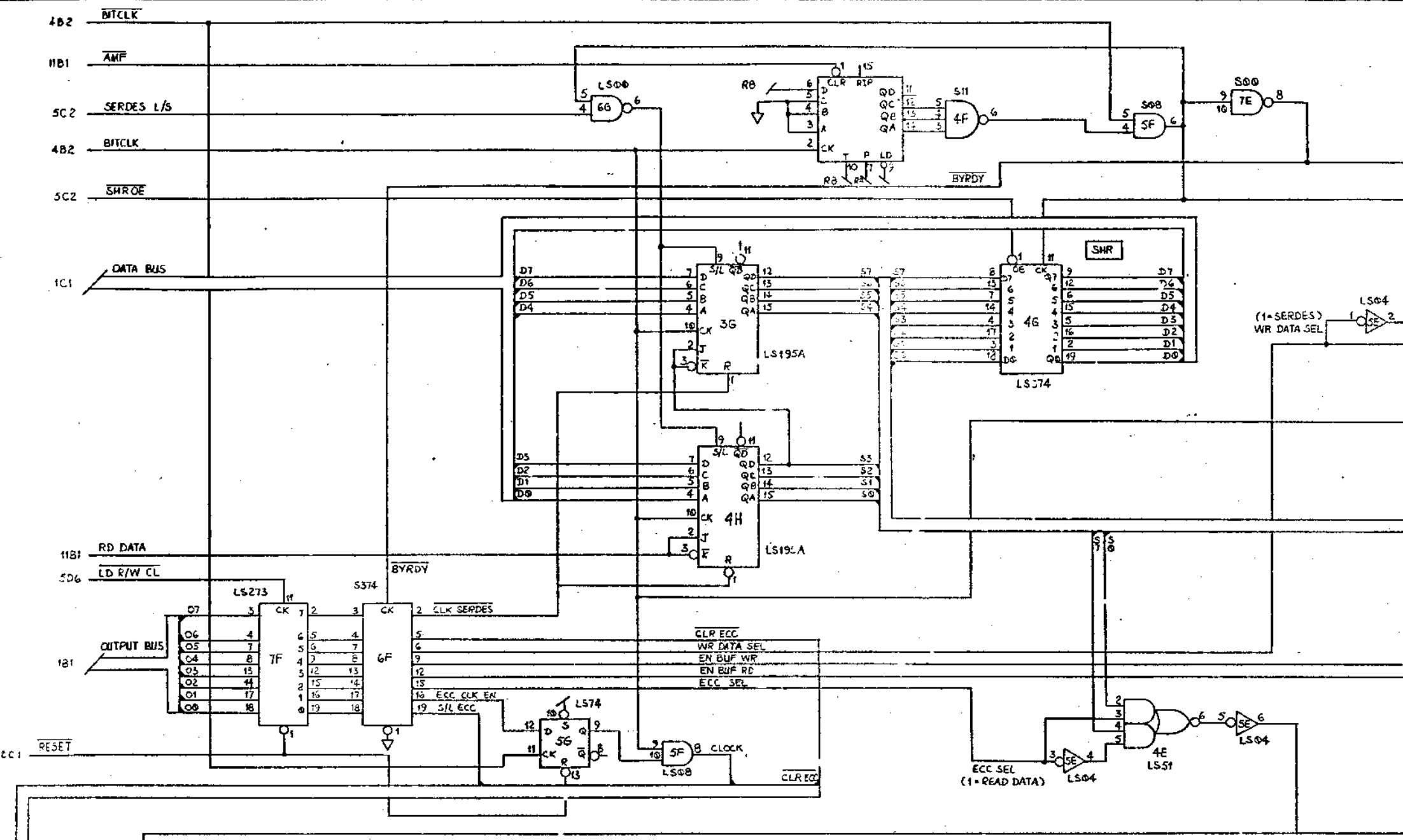

QTY REQD		PCHM NO.		PART OR IDENTIFYING NO.		NOMENCLATURE OR DESCRIPTION		NATERIAL SPECIFICATION	
PARTS LIST									
UNLESS OTHERWISE SPECIFIED DIMENSIONS ARE IN INCHES TOLERANCES ARE: FRACTIONS DECIMALS ANGLES .XXX -									
CONTRACT NO.		SA 1403							
APPROVALS		DATE 19-8-80							
DRAWN		L TSENG							
CHECKED									
ISSUED									
MATERIAL		SA 1403 CONTROLLER SERIALIZER/DESERIALIZER							
FRM/N		SIZE PCHM NO.		DWG. NO.		REV.		REV.	
NEXT ASSY		USED ON		D 01000 - 00006		B1		B1	
APPLICATION		DO NOT SCALE DRAWING							
SCALE		SHEET 6 OF 13							

D

C

B

A

REVISIONS				
ZONE	REV	DESCRIPTION	DATE	APPROVED

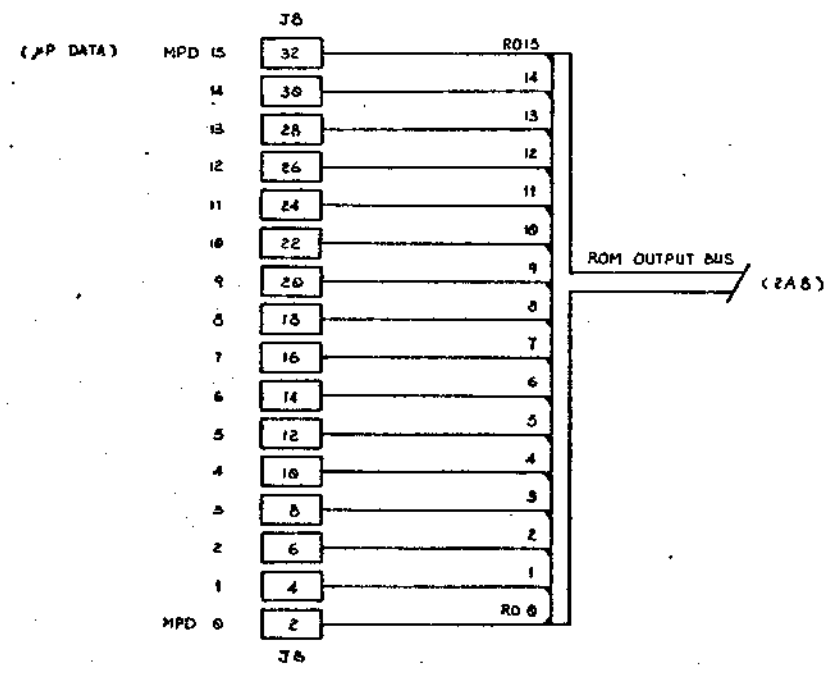
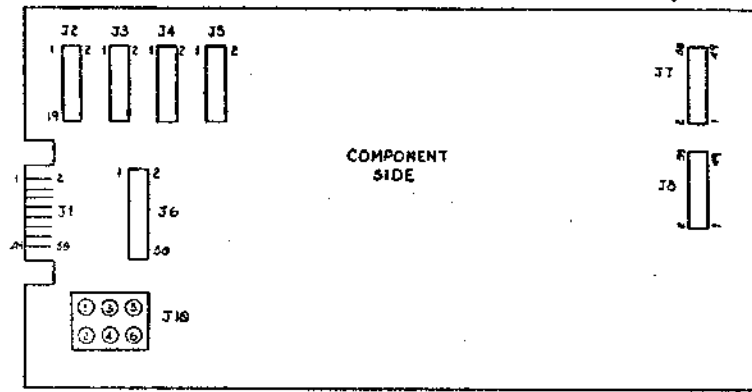
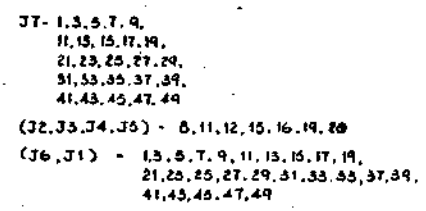
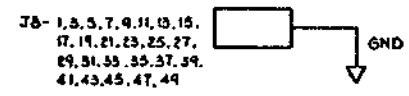
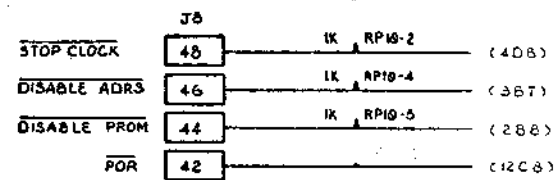
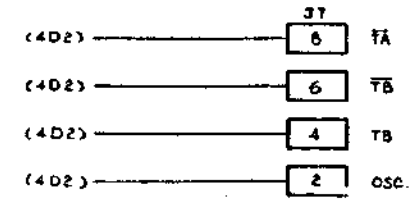
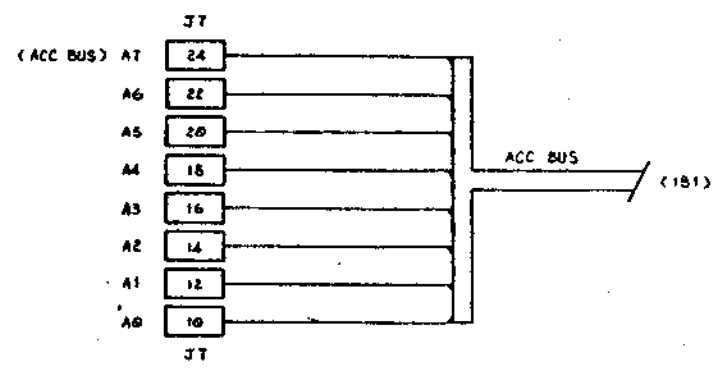
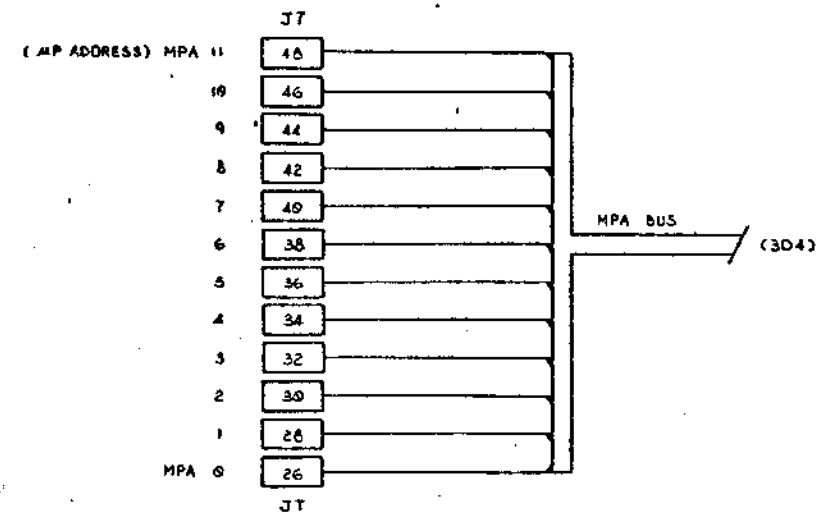

QTY	FRM	PART OR IDENTIFYING NO.	DESCRIPTION OR DESCRIPTION	MATERIAL SPECIFICATION
PARTS LIST				
UNLESS OTHERWISE SPECIFIED DIMENSIONS ARE IN INCHES TOLERANCES ARE:		CONTRACT NO. SA 1403		
FRACTIONS DECIMALS ANGLES		APPROVALS DATE		
1/16 0.0005 15/16		DRAWN C. THEIN 9-13-89		
MATERIAL		CHECKED		
FINISH		ISSUED		
NEXT ASSEMBLY USED ON		SCALE		
APPLICATION		DO NOT SCALE DRAWING		
		Dwg. No. 01000-00006		REV. B1
		SHEET 8 OF 15		

D
C
B
A

REVISIONS				
ZONE	REV	DESCRIPTION	DATE	APPROVED

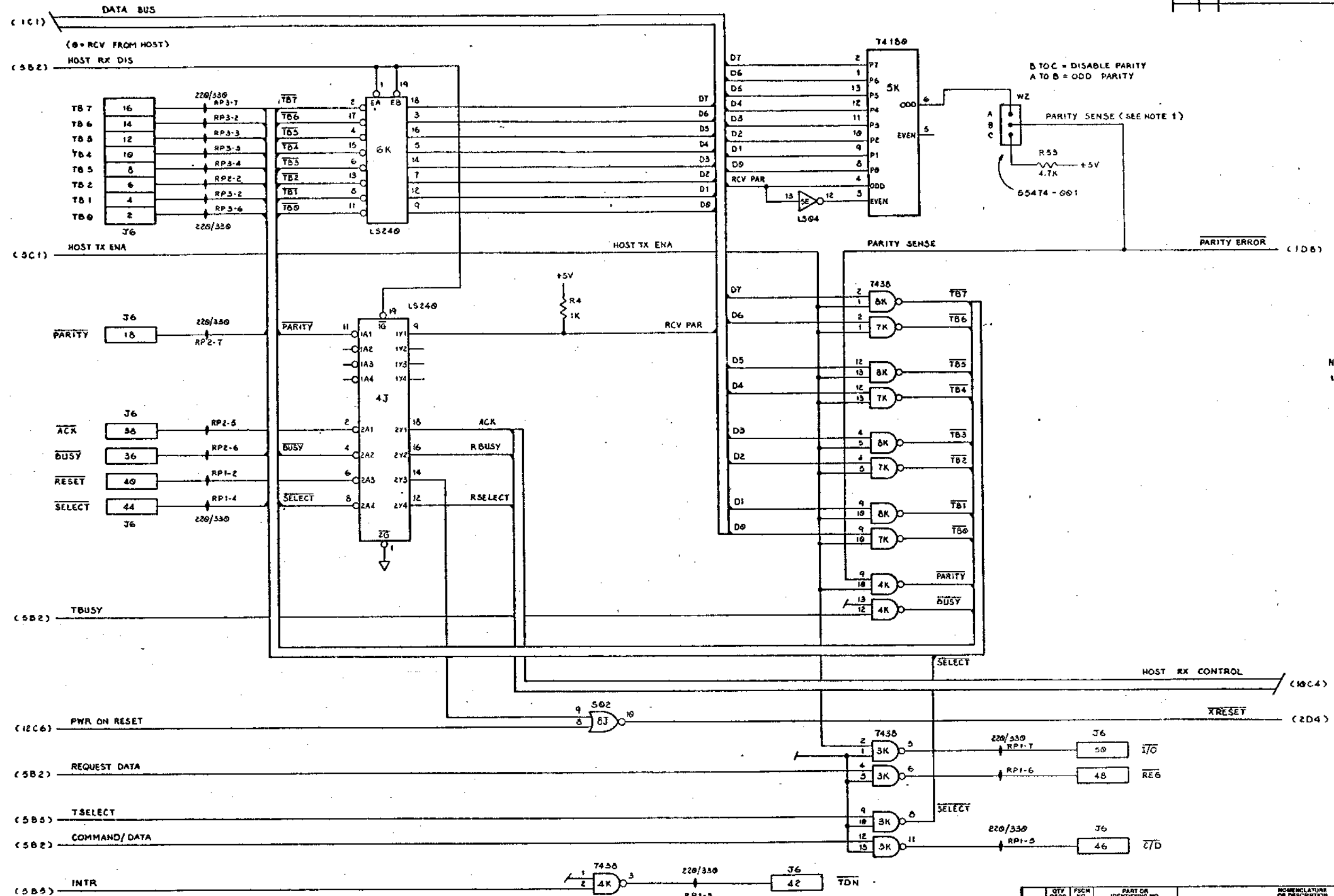

NOTES:
 1. UPON XMISSION, 'PARITY SENSE' IS THE PARITY BIT SENT TO THE HOST. 'RCV PAR' IS BIASED TO 1. UPON RECEPTION 'PARITY SENSE' IS THE 'PARITY ERROR' INDICATOR; 0 = ERROR.

QTY	FRSH	PART OR IDENTIFYING NO.	NOMENCLATURE OR DESCRIPTION	MATERIAL SPECIFICATION

UNLESS OTHERWISE SPECIFIED DIMENSIONS ARE IN INCHES TOLERANCES ARE: FRACTIONS DECIMALS ANGLES ± .XX ± .XXX ± °		CONTRACT NO. SA 1403	
APPROVALS	DATE	SA 1403 CONTROLLER HOST INTERFACE	
DRAWN C. THE IN	9-15-80	CHECKED	ISSUED
FINISH			
NEXT ASSY	USED ON		
APPLICATION	DO NOT SCALE DRAWING		

SIZE	FRSH NO.	DWG. NO.	REV.
D		01000-00006	B1
SCALE			SHEET 9 OF 13

REVISIONS				
ZONE	REF	DESCRIPTION	DATE	APPROVED

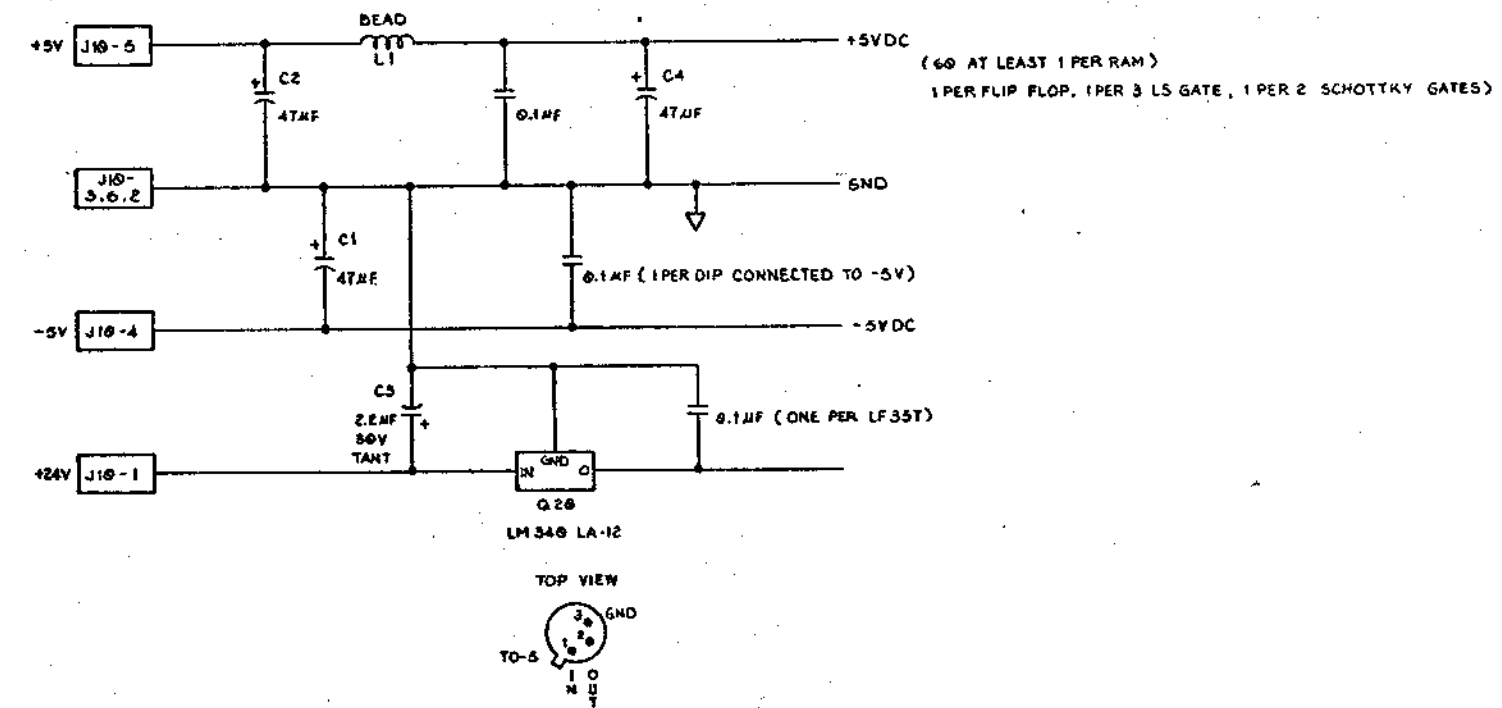
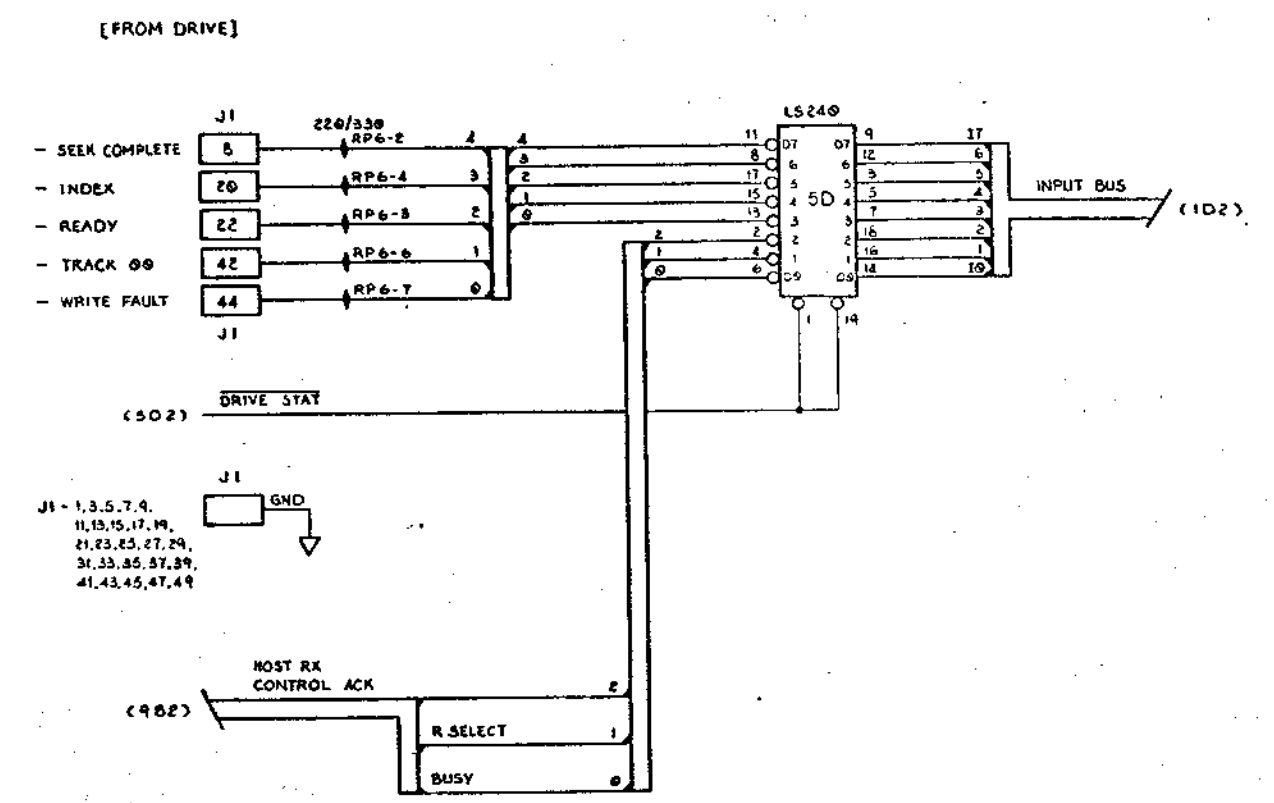
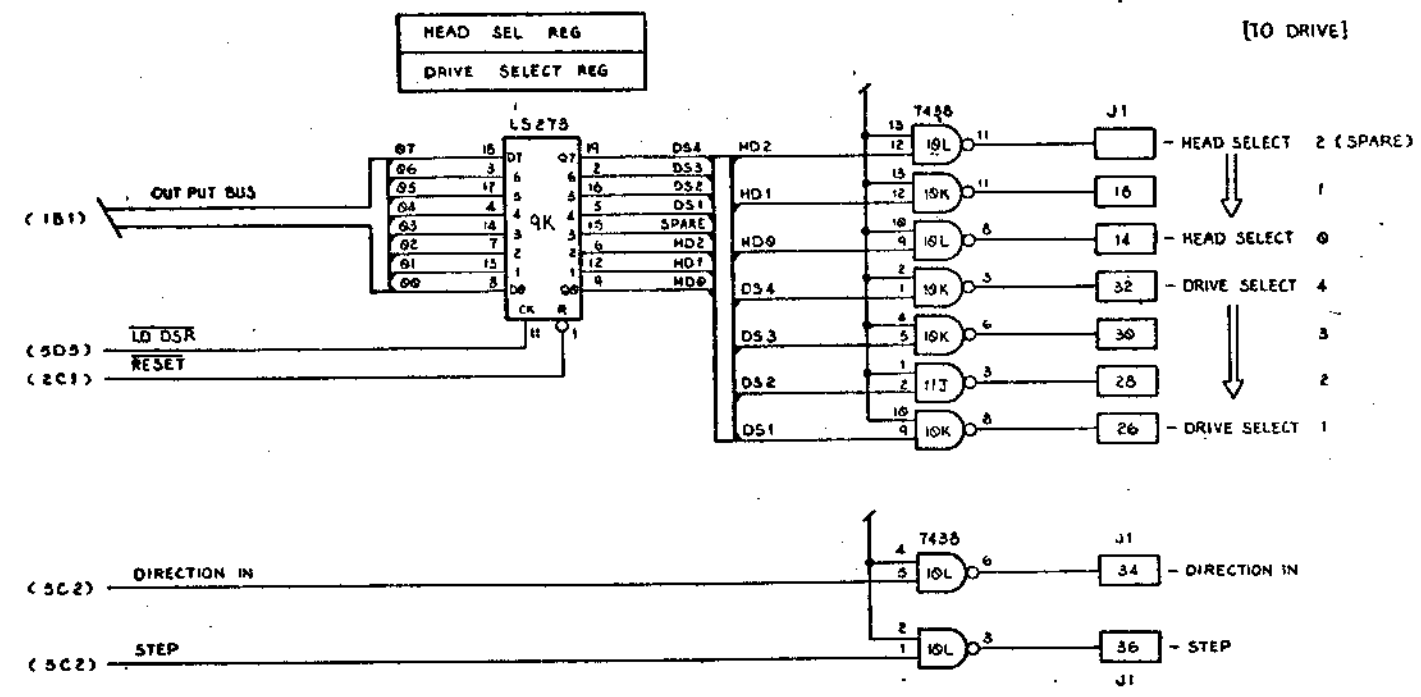

QTY	FROM	PART OR IDENTIFYING NO.	NOMENCLATURE OR DESCRIPTION	MATERIAL SPECIFICATION
PARTS LIST				
UNLESS OTHERWISE SPECIFIED DIMENSIONS ARE IN INCHES FRACTIONS DECIMALS ANGLES		CONTRACT NO. SA 1403		
DRAWN C. THEIN		DATE 9-17-60		
CHECKED		ISSUED		
NEXT ASSY	USED ON	SCALE	SIZE FROM NO. D	DWG. NO. 01000-00000
APPLICATION		DO NOT SCALE DRAWING		SHEET 10 OF 15

DIC Data Technology Corporation
SA 1403 CONTROLLER
DRIVE INTERFACE, CONTROL CABLE

DRAWN: C. THEIN
 DATE: 9-17-60
 CHECKED: []
 ISSUED: []
 SCALE: []
 SIZE FROM NO.: D
 DWG. NO.: 01000-00000
 SHEET 10 OF 15

REVISIONS				
ZONE	REL.	DESCRIPTION	DATE	APPROVED

D

C

B

A

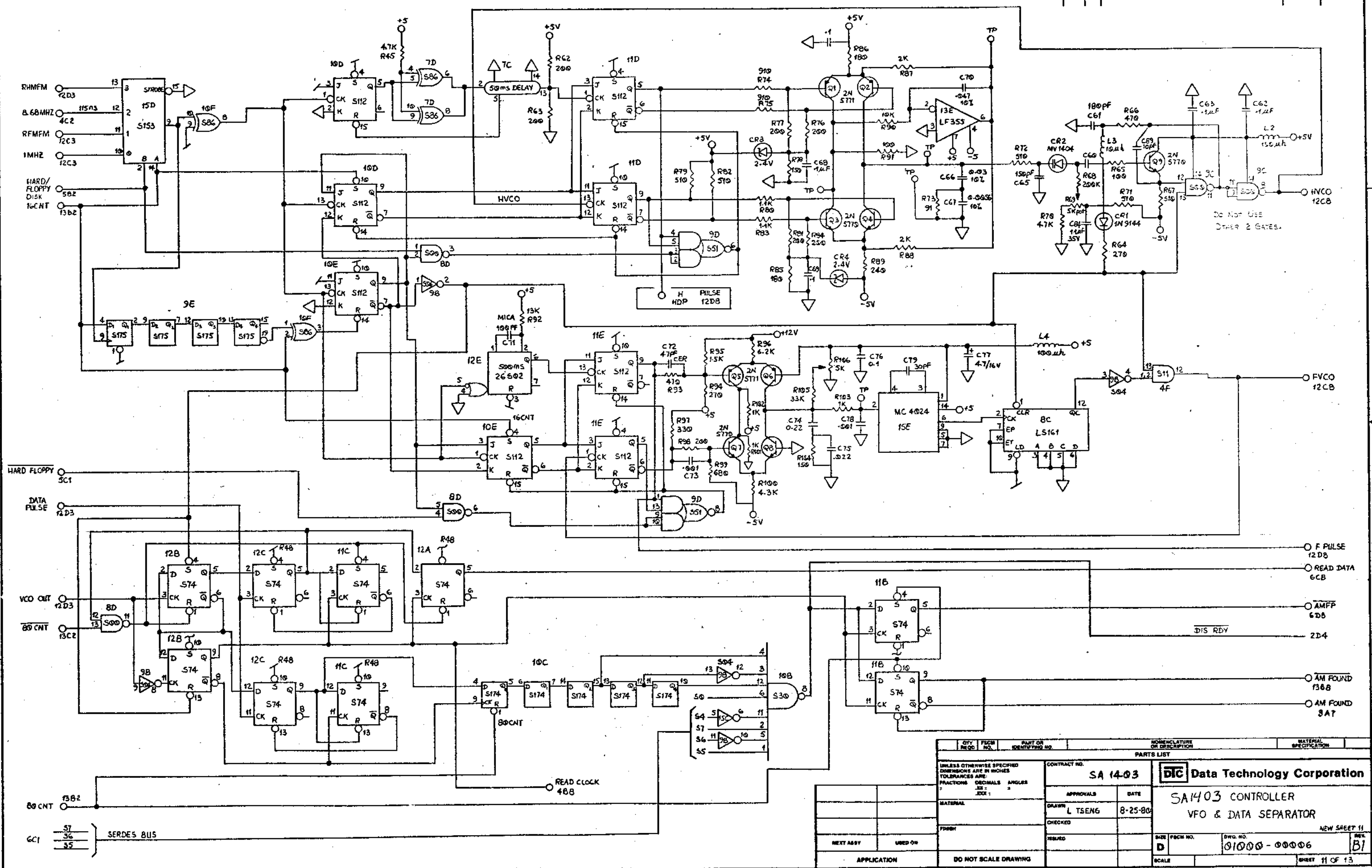

QTY REQD.		PART OR IDENTIFYING NO.		NOMENCLATURE OR DESCRIPTION		MATERIAL SPECIFICATION	
PARTS LIST							
UNLESS OTHERWISE SPECIFIED DIMENSIONS ARE IN INCHES TOLERANCES ARE: FRACTIONS DECIMALS ANGLES				CONTRACT NO. SA 14-03			
DRAWN L TSENG				DATE 8-25-80			
CHECKED				APPROVALS			
PREPARED				DATE			
NEXT ASSY				USED ON			
APPLICATION				DO NOT SCALE DRAWING			
D		SA 1403 CONTROLLER VFO & DATA SEPARATOR		NEW SHEET 11		REV. B1	
SCALE		Dwg. No. 01000-00006		SHEET 11 OF 13			

REVISIONS			
ZONE	REV.	DESCRIPTION	DATE

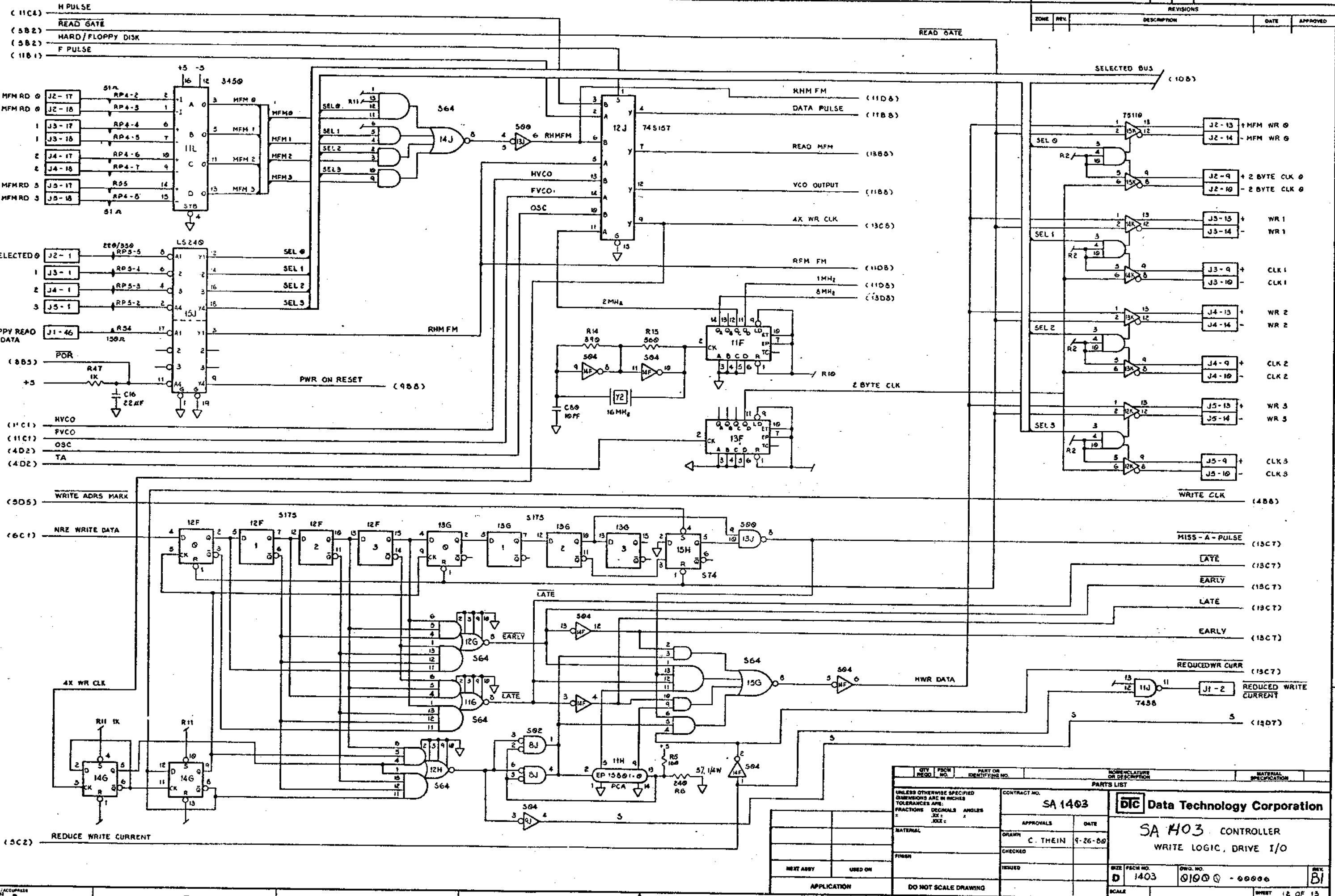

QTY FROM		PART OR IDENTIFYING NO.		NOMENCLATURE OR DESCRIPTION		MATERIAL SPECIFICATION	
UNLESS OTHERWISE SPECIFIED DIMENSIONS ARE IN INCHES TOLERANCES ARE:				CONTRACT NO. SA 1403			
FRACTIONS DECIMALS ANGLES				APPROVALS DATE			
3/16 0.001 1/16				C. THEIN 9-26-80			
MATERIAL				DRAWN			
FINISH				CHECKED			
NEXT ASSY				ISSUED			
USED ON				SIZE FECH NO. D 1403			
APPLICATION				DO NOT SCALE DRAWING			
				OWN. NO. 01000 - 00000			
				SCALE			
				REV. B1			
				SHEET 12 OF 15			

D
C
B
A

REVISIONS				
ZONE	REV	DESCRIPTION	DATE	APPROVED

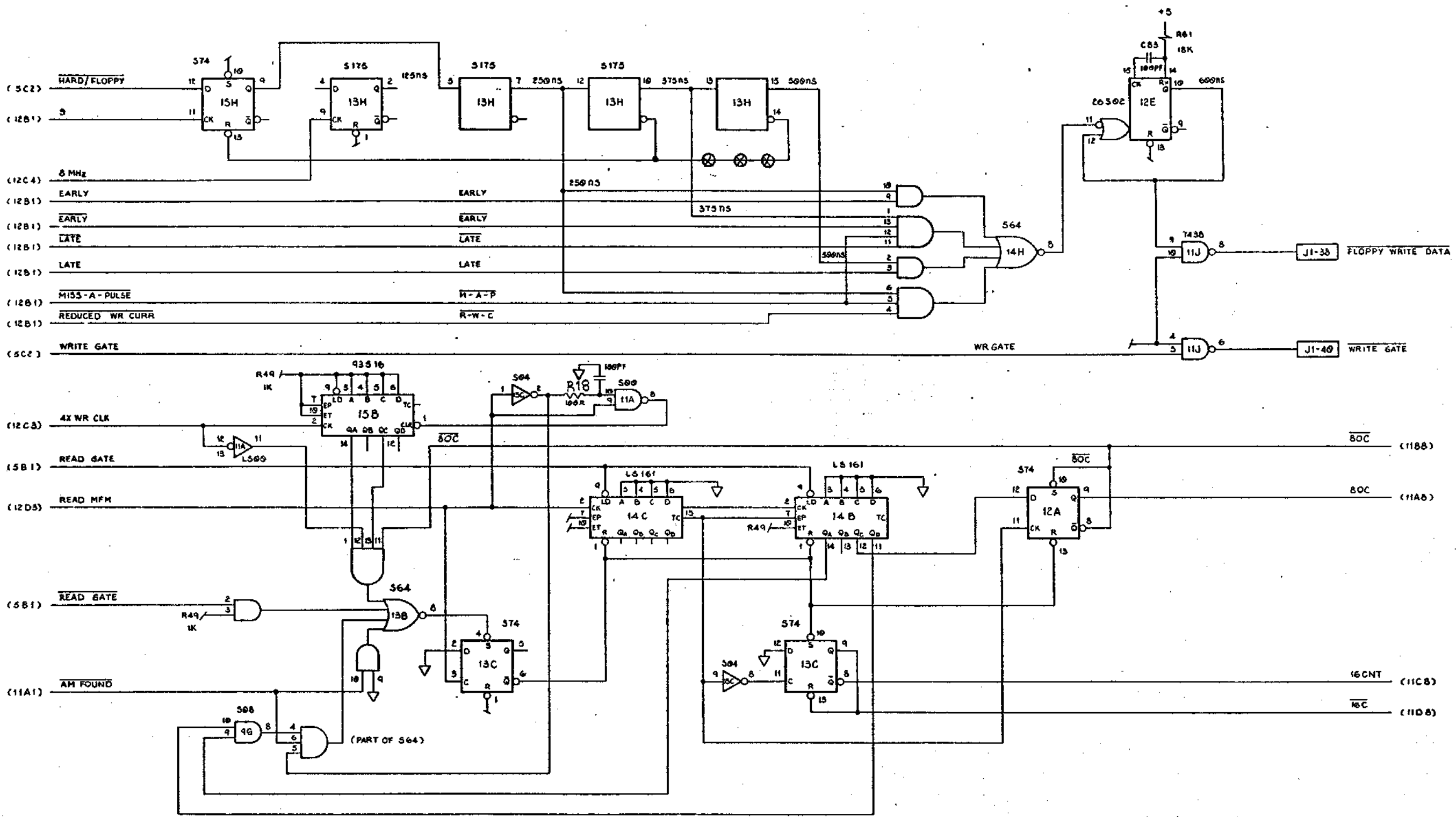

QTY	PRICE	PART OR IDENTIFYING NO.	NOMENCLATURE OR DESCRIPTION	MATERIAL SPECIFICATION
PARTS LIST				
UNLESS OTHERWISE SPECIFIED DIMENSIONS ARE IN INCHES TOLERANCES ARE: FRACTIONS DECIMALS ANGLES			CONTRACT NO. SA 1403	
DRAWN C. THEIN			DATE 9-30-80	
CHECKED			ISSUED	
NEXT ASSY			USED ON	
APPLICATION			DO NOT SCALE DRAWING	
SA 1403 CONTROLLER			FLOPPY WRITE PRECOMP & RDMFM ZEROES DETECT	
SIZE D			REV B1	
SCALE			SHEET 13 OF 13	