

3302

**PCC** PERTEC  
COMPUTER  
CORPORATION  
PERIPHERALS DIVISION

HS/D-72

**PCC** PERTEC  
COMPUTER  
CORPORATION  
PERIPHERALS DIVISION

9600 Irondale Avenue, Chatsworth, California 91311, Phone (213) 882-0030, TWX (910) 494-2093

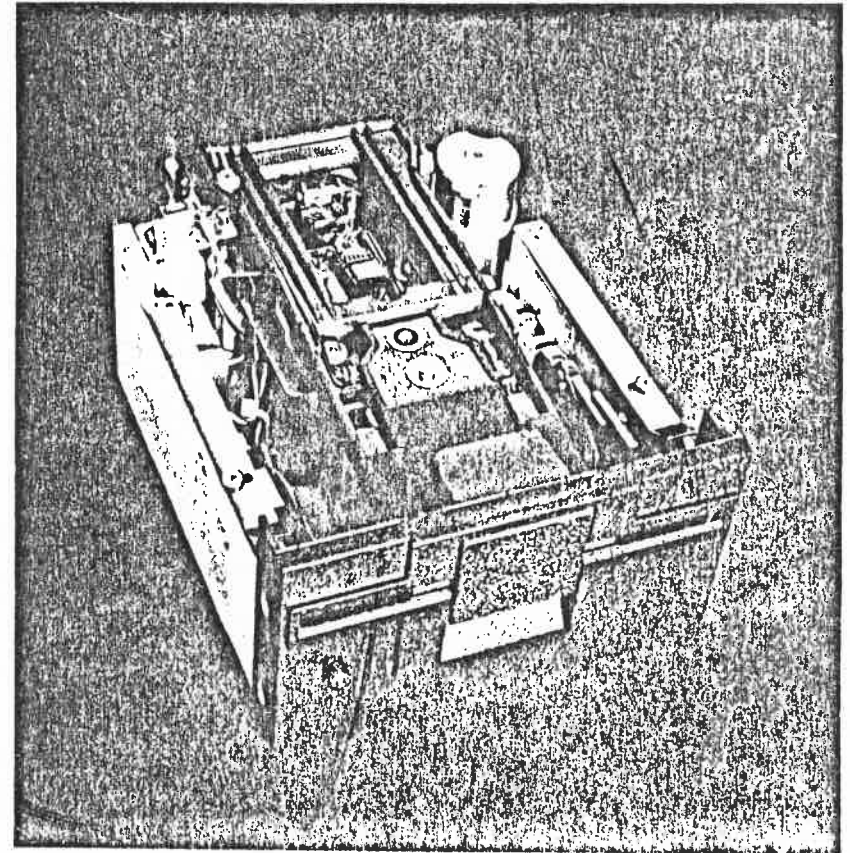

**MODEL FD250 FLEXIBLE DISK DRIVE  
OPERATING AND SERVICE MANUAL NO. 600508**

TABLE OF CONTENTS

FOREWORD

This manual provides operating and service instructions for the FD250 Flexible Disk Drive, manufactured by the Pertec Computer Corporation, Peripherals Division (PCC PD), Chatsworth, California.

The contents include specifications, installation and operating instructions and a photo parts list.

PROPRIETARY NOTICE

Information contained in this document is copyright by Pertec Computer Corporation and may not be duplicated in full or in part by any person without prior written approval of Pertec Computer Corporation. Its purpose is to provide the User with adequately detailed documentation so as to efficiently install, operate, maintain, and order spare parts for the equipment supplied. Every effort has been made to keep the information contained in this document current and accurate as of the date of publication or revision. However, no guarantee is given or implied that the document is error-free or that it is accurate with regard to any specification.

Page

SECTION I — GENERAL DESCRIPTION AND SPECIFICATIONS

1.1	Introduction	1
1.2	Purpose of Equipment	1
1.3	Physical Description of Equipment	1
1.4	Functional Description	2
1.5	Mechanical and Electrical Specifications	2
1.6	Interface Specifications	2
1.7	Uncrating the Disk Drive	2
1.8	Physical Checkout	3
1.9	Interface Connections	4
1.10	DC Power Requirements	4
1.11	Chassis Ground	4
1.12	Mounting the Disk Drive	4
1.12.1	Hardware	4
1.12.2	Dust Cover	4
1.12.3	Cooling	4
1.12.4	Drive Separation	5
1.13	Diskettes	5
1.14	Diskette Handling and Storage	6
1.15	Loading the Diskette	7
1.16	Write Protect	8

SECTION II — THEORY OF OPERATION

2.1	Introduction	9
2.2	Organization of the Disk Drive	9
2.3	Functional Block Diagram Description	9
2.3.1	Head Load Driver	9
2.3.2	Index Pulse Shaper	9
2.3.3	Write Protect	9
2.3.4	Track 0 Switch	11
2.3.5	Spindle Drive Control	11
2.3.6	Positioner Control	11
2.3.7	Data Electronics	11

SECTION III — OPERATION

3.1	Introduction	14
3.2	Physical Description, PCBA No. 600491	14
3.3	Interface Electronics Specifications	14
3.3.1	Input Control Lines	16
3.3.2	Output Status Lines	17
3.4	Circuit Board Test Points	17
3.4.1	Logic Ground (TP1)	17
3.4.2	Differentiated Read Signal (TP3, TP4)	17
3.4.3	Read Data Single Shot (TP9)	17
3.4.4	Index Pulse (TP2)	17
3.4.5	Amplified Read Signal (TP5, TP6)	17
3.4.6	Write Gate (TP7)	17
3.4.7	Analog Ground (TP8)	17
3.4.8	Trim Erase Driver (TP10)	17
3.5	Option Select	17
3.5.1	Head Load with Select	17
3.5.2	Head Load with Drive Motor Enable	18
3.5.3	Spindle Drive Enable with Diskette in Place and Drive Motor Enable	18
3.5.4	Spindle Drive Enable with Drive Motor Enable	18
3.5.5	Busy Indicator with Select	18
3.5.6	Busy Indicator with Busy	18
3.5.7	Head Selection with Head Select	18
3.5.8	Head Selection with Direction Select	18
3.5.9	Select Switch, S1	18
3.6	Maintenance Philosophy	18
3.6.1	Cleaning the Heads	18

	Page
3.7 Adjustment .....	18
3.7.1 Drive Motor Speed .....	18
3.7.2 CE Alignment .....	19
3.7.3 Track 0 Switch .....	20
3.7.4 Write Protect Switch .....	20
3.7.5 Diskette In Place Switch .....	20
 SECTION IV — PARTS LISTS AND SCHEMATIC/ASSEMBLY DRAWINGS	
4.1 Introduction .....	21
4.2 Illustrated Parts Breakdown (IPB) .....	21
4.3 Recommended Spare Parts .....	21

LIST OF ILLUSTRATIONS

Figure		Page
1-1	FD250 Disk Drive .....	1
1-2	Physical Dimensions .....	5
1-3	Recording Medium .....	6
1-4	Diskette Care and Handling .....	7
1-5	Write Protect Tab .....	8
2-1	FD250 Functional Block Diagram .....	10
2-2	Single Density Recording .....	11
2-3	Write Timing Diagram .....	12
2-4	Read Timing Diagram .....	13
3-1	FD250 PCBA No. 600491, Test Point and Connector Placement .....	14
3-2	Interface Configuration .....	15
3-3	Cats Eye Pattern .....	19
3-4	Index to Data Burst .....	20
4-1	FD250, Top View .....	22
4-2	FD250, Bottom View .....	24
4-3	FD250 Bottom View, PCBA Removed .....	25

LIST OF TABLES

Table		Page
1-1	Mechanical and Electrical Specifications .....	3
3-1	Interface Connector Pin Assignments, J1/P1 .....	15
3-2	Power Connector Pin Assignment, J3/P3 .....	15
4-1	FD250 Photo Parts Index .....	23
4-2	FD250 Photo Parts Index .....	24
4-3	FD200/FD250 Photo Parts Index .....	25
4-4	FD250 Recommended Spare Parts List .....	26

SECTION I  
GENERAL DESCRIPTION AND SPECIFICATIONS

1.1 INTRODUCTION

This section provides a physical description, functional description, and specifications of the FD250 Flexible Disk Drive, manufactured by the Perlec Computer Corporation, Peripherals Division (PCC PD), Chatsworth, California.

In addition to the unique features described, the following features are included in all models.

- Write Protect Sensor. Used to disable the disk drive write electronics, thus preventing overwriting the protected diskettes.
- Trim erase timing circuits internal to the disk drive.
- Diskette in place sensor. Used to stop the spindle drive motor rotation when no diskette is installed.

1.2 PURPOSE OF EQUIPMENT

The FD250 disk drive is a compact disk memory device designed for random access data storage, data entry, and data output applications. These applications typically are intelligent terminal controllers, microcomputers, word processing systems, data communications systems, error logging and microprogram logging, and point of sale terminals.

The FD250 has the capability of recording and reading digital data using a single density (FM) or a double density (MFM or M<sup>2</sup>FM) encoding technique.

1.3 PHYSICAL DESCRIPTION OF EQUIPMENT

The FD250 flexible disk drive is shown in Figure 1-1. The drive can be mounted in any vertical or horizontal plane; however, when mounted horizontally, side 1 of the diskette must be uppermost.

The mechanical components of the drive consist of a belt-driven spindle which is driven by a dc motor, and a stepper motor/cam combination. This combination is used for positioning the magnetic read/write/erase head assemblies.

The read/write/erase head assemblies are glass-bonded ferrite/ceramic structures which have a life expectancy in excess of 20,000 hours.

Operator access for diskette loading is provided via a latched slot located on the front of the unit.

The electronic components of the drive are mounted on a single PCBA which is located beneath the chassis. Power and interface signals are routed through connectors which plug directly into the PCBA.

NOTE

Information regarding format and control of PCC flexible disk drives is contained in a series of Application Notes, PCC document numbers 75605, 75607, and 76601 and may offer guidelines to the user.

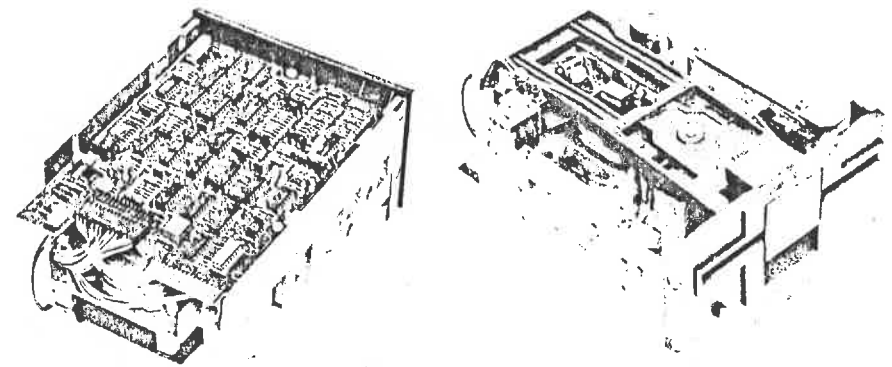

3248

3249

Figure 1-1. FD250 Disk Drive

#### 1.4 FUNCTIONAL DESCRIPTION

The FD250 is fully self contained and requires no operator intervention during normal operation. The drive consists of a spindle drive system, head load and positioning system, and read/write and erase system.

When the front latch is opened, access is provided for the insertion of a diskette. The diskette is positioned in a lateral and up/down direction by internal cartridge guides. In/out location is provided by ensuring that the diskette is inserted until a back stop is encountered.

Closing the front latch activates the cone/clamp system resulting in (1) centering the recording medium and (2) clamping the diskette to the drive hub. The drive hub is driven at a constant speed of 300 rpm by a dc motor.

In operation, the magnetic heads are loaded into contact with the recording medium by the head load system. For reliable operation, it is important that the head/diskette relationship is controlled. This is accomplished by:

- (1) Referencing the diskette to a platen surface.
- (2) Referencing the head surfaces to the same platen surface as the diskette.
- (3) Providing pressure pads which apply a loading force of 18 to 20 grams to the opposite side of the recording medium from each head.

The magnetic heads are positioned over the desired track by means of a 4-phase stepper motor/cam assembly and its associated electronics. This positioner employs a 2-step movement to cause a 1-track linear motion.

When a write protected diskette is inserted into the drive, the Write Protect Sensors disable the write electronics of the drive.

A single density recording scheme is typically employed in the FD250 flexible disk drive. Data storage capacity may be doubled by use of a double density encoding scheme, such as MFM or M<sup>2</sup>FM.

When performing a write operation, an 0.33 mm (0.013-inch) (nominal) data track is recorded. This track is then tunnel erased to 0.30 mm (0.012 inch) (nominal).

Data recovery electronics include a low-level read amplifier, differentiator, zero-crossing detector, and digitizing circuits. No data decoding facilities are provided in the basic drive.

The drive is also supplied with the following sensor systems.

- (1) A Track 0 switch which senses when the Head/Carriage assemblies are positioned at Track 0.
- (2) An Index sensor, which consists of an LED light source and phototransistor, is positioned such that when an index hole is detected, a digital signal is generated. The index sensor is a high resolution device which can distinguish holes placed close together, i.e., hard-sectored (multi-hole) diskettes.
- (3) A Diskette In Place sensor which stops the rotation of the spindle drive motor when no diskette is installed.

#### 1.5 MECHANICAL AND ELECTRICAL SPECIFICATIONS

The mechanical and electrical specifications for the flexible disk drive family are given in Table 1-1.

#### 1.6 INTERFACE SPECIFICATIONS

Levels: True = +0.2v (±0.2v) approximately

False = +3.0v approximately

Pulses: Levels as above.

The interface circuits are designed so that a disconnected wire results in a false signal.

#### 1.7 UNCRATING THE DISK DRIVE

The disk drive is shipped in a protective container which, when bulk packaged, meets the National Safe Transit Specification (Project 1A, Category 1). The container is designed to minimize the possibility of damage during shipment. The following procedure describes the recommended method for uncrating the disk drive.

- (1) Place the shipping container on a flat work surface. Ensure that the carton is positioned as indicated on the carton.
- (2) Remove the bands from around the inner container.
- (3) Remove the upper half of the inner container.
- (4) Remove the disk drive from the lower half of the inner container.
- (5) Check the contents of the shipping container against the packing slip. Investigate the contents for possible damage; notify the carrier immediately if any damage is noted.

Table 1-1  
Mechanical and Electrical Specifications

Media	Industry-compatible 5¼-inch diskette
Tracks per inch	48
Number of Tracks	70 (both surfaces)
Read/Write Track Width	0.30 mm (0.012 inch)
Dimensions	
Height	82.55 mm (3.25 inches)
Width	146.05 mm (5.75 inches)
Depth	203.2 mm (8.0 inches)
Weight	1.45 kg (3.2 pounds)
Temperature	
Operating	10°C to 42°C (50°F to 108°F)
Non-operating	-40°C to 71°C (-40°F to 160°F)
Relative Humidity	
Operating	20% to 80%
Non-operating	5% to 95% (non-condensing)
Vibration	6-600 Hz 0.5g peak
Seek Time	25 msec track-to-track
Head Settling Time	10 msec (last track addressed)
Head Loading Time	35 msec (maximum)
Error Rate	1 per 10 <sup>9</sup> recoverable (maximum) 1 per 10 <sup>12</sup> non-recoverable (maximum)
Head Life	20,000 hours (normal use)
Media Life	3 million passes on a single track
Disk Speed	300 rpm ± 1.5%
Instantaneous Speed Variation	± 1.0%
Start/Stop Time	1 second (maximum)
Transfer Rate	125/250k bits/sec
Recording Density (inside track, upper head)	2728/5456 bpi
Bits per Side per Disk (unformatted)	875k/1.75M (maximum)
Bits per Track	25,000/50,000 (maximum)
Recording Mode	FM single/MFM double density
Power	+ 12v dc ± 0.6v, 1.6 amps maximum 5v dc ± 0.25v, 0.8 amps maximum

#### 1.8 PHYSICAL CHECKOUT

Before applying power to the unit and before integrating it into a system, the following inspections should be performed.

- (1) Check that the front access latch opens and closes. Note that when the latch is opened, the head-load arm raises.
- (2) Remove the protective insert from the drive.
- (3) Ensure that the bezel is secure.
- (4) Manually rotate the drive hub. The hub should rotate freely.
- (5) Manually rotate the stepper motor cam. The cam should rotate without hindrance and should cause the head carriage to advance and retract as the cam is rotated alternately clockwise and counterclockwise.
- (6) Check that the PCBA is secure. Access to the PCBA is from the bottom of the drive. Check that the connectors are firmly seated.

#### CAUTION

OPERATION OF THE DISK DRIVE WITH THE UNIT SITTING HORIZONTALLY ON A FLAT SURFACE WITH NO PROVISION FOR AIR FLOW BENEATH THE UNIT MAY CAUSE OVERHEATING. DO NOT OPERATE THE DRIVE IN THIS CONFIGURATION FOR AN EXTENDED PERIOD.

## 1.9 INTERFACE CONNECTIONS

Signal connections for the FD250 are made via a user-supplied 34-pin flat ribbon connector (3M Part No. 3463-0001, or equivalent). This connector mates directly with the PCBA connector at the rear of the drive. Power connections are divided for dc requirements. The dc connector is a 4-pin connector (Amp Mate-N-Lok, Part No. 1-480424-0) which mates with the PCBA connector at the rear of the drive. The interface description of the connectors, and the location of each, is contained in Section III.

The signal connector harness should be of the flat ribbon type with the following characteristics.

- (1) Maximum length of 9.14 m (30 feet).
- (2) 30 gauge conductor compatible with the connector to be used.

## 1.10 DC POWER REQUIREMENTS

- + 12 ± 0.6v dc: 1.6 amp (maximum)
- + 5 ± 0.25v dc: 0.8 amp (maximum), 100 mv ripple

### NOTE

*If the unit is intended to be used in a system listed by Underwriters Laboratories, Inc. and/or Canadian Standards Association (UL/CSA approved), the dc supplies must be current limited (fused) to 5 Amperes maximum.*

Power connections should be made with 18 AWG cable (minimum). In addition, the PCBA mounted dc power connector is keyed.

## 1.11 CHASSIS GROUND

To ensure proper operation of the drive, the chassis should be connected to earth ground. The circuit board hold down screw, located at the rear of the chassis, holds a lug which is provided to facilitate this connection.

## 1.12 MOUNTING THE DISK DRIVE

The drive has been designed such that it can be mounted in any plane, i.e., upright, horizontal, or vertical. The only mounting restriction is that when mounted horizontally, the label side of the diskette must be the uppermost side. Tapped holes are provided in various locations for the attachment of user-supplied hardware. Figure 1-2 shows the location of the recommended mounting holes.

The user should comply with the guidelines contained in the following paragraphs when designing an enclosure for the flexible disk drive. Outline dimensions are shown in Figure 1-2.

### 1.12.1 HARDWARE

The flexible disk drive is a precision device in which certain critical internal alignments must be maintained. Therefore, in keeping with rigid disk requirements, it is important that the mounting hardware does not introduce significant stress on the drive.

Any mounting scheme in which the drive is part of the structural integrity of the enclosure is not permitted.

Since the disk drive cannot be subjected to significant stress when it is slide mounted, this type of mounting generally satisfies the foregoing requirements.

Mounting schemes should allow for adjustable brackets or incorporate resilient members to accommodate tolerances.

Mounting schemes involving more than two hard mounting points and a third point should be avoided.

### 1.12.2 DUST COVER

Since the flexible disk drive is not provided with a dust cover, the design of an enclosure should incorporate a means to prevent direct ingress of loose items, e.g., dust, paper punch waste, etc.

### 1.12.3 COOLING

Heat dissipation from a single disk drive is normally 12 watts (40 Btu/Hr) and a maximum of 22 watts (74 Btu/Hr) under high line conditions. When the drive is mounted so that the components have access to the free flow of air, normal convection cooling allows operation over the specified temperature range.

When the drive is mounted in a confined environment, air flow may have to be provided to maintain specified air temperatures in the vicinity of the motors, PCBA, and diskette.

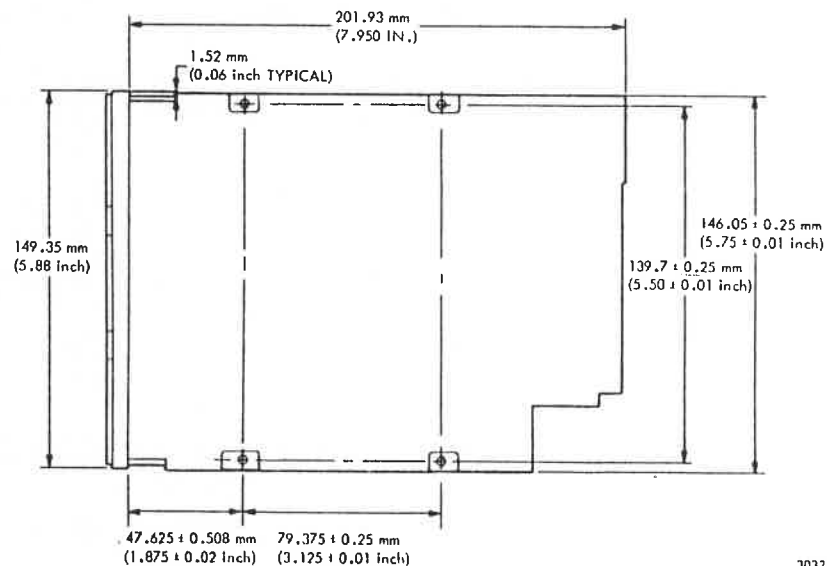
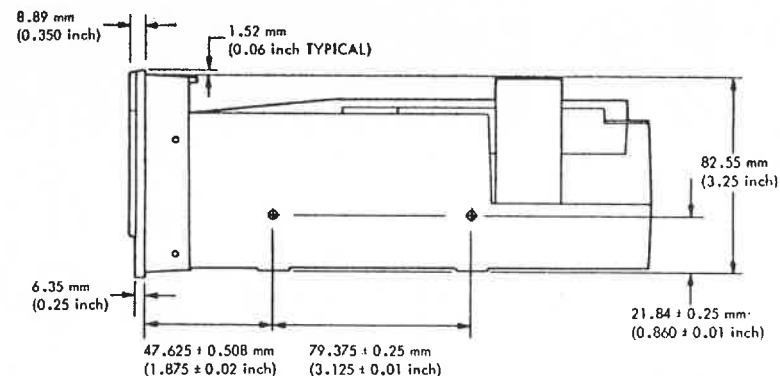

Figure 1-2. Physical Dimensions

## 1.12.4 DRIVE SEPARATION

In addition to the cooling requirements specified in Paragraph 1.12.3, a minimum separation of 25.4 mm (1 inch) between drives is recommended. This is required to avoid electrical interference between the motors of one drive and the magnetic heads of another drive. Closer mounting is allowable if a grounded sheet of steel at least 1.52 mm (0.060-inch) thick is interposed between units. However, use of this steel sheet may increase the cooling requirements.

## 1.13 DISKETTES

The standard 133.4 mm (5.25 inch) diskette is designed for use with a format in which sector mark information may be prerecorded on the diskette. In this case, a single index hole is provided for reference purposes. Detection of this hole is accomplished by an index phototransistor/LED combination.

Other diskettes available are designed with multiple sector holes which provide sector mark information, via the same circuitry that is used in the single hole configuration.

Figure 1-3 is a simplified drawing of the diskette used with the flexible disk drive. It can be seen that the recording medium is a flexible magnetic disk enclosed in a protective jacket. The disk, which is free to rotate within the jacket, is continuously cleaned by the soft fabric inner lining of the jacket during normal operation. The protective jacket is provided with various holes and slots to provide access for the magnetic heads and sensor assemblies.

### 1.14 DISKETTE HANDLING AND STORAGE

It is important that the diskette be handled and stored properly so that the integrity of the recorded data is maintained. A damaged or contaminated diskette can impair or prevent recovery of data and can result in damage to the read/write heads.

Figure 1-3 illustrates the physical configuration of the diskette. The diskette is an oxide coated, flexible mylar disk, 130.2 mm (5.125 inches) in diameter, and is enclosed in a 133.4 mm x 133.4 mm (5.25 x 5.25 inch) protective jacket. Read/write/erase head access is made through an aperture in the jacket. Openings for the drive hub, diskette index hole, and write protect sensor are also provided.

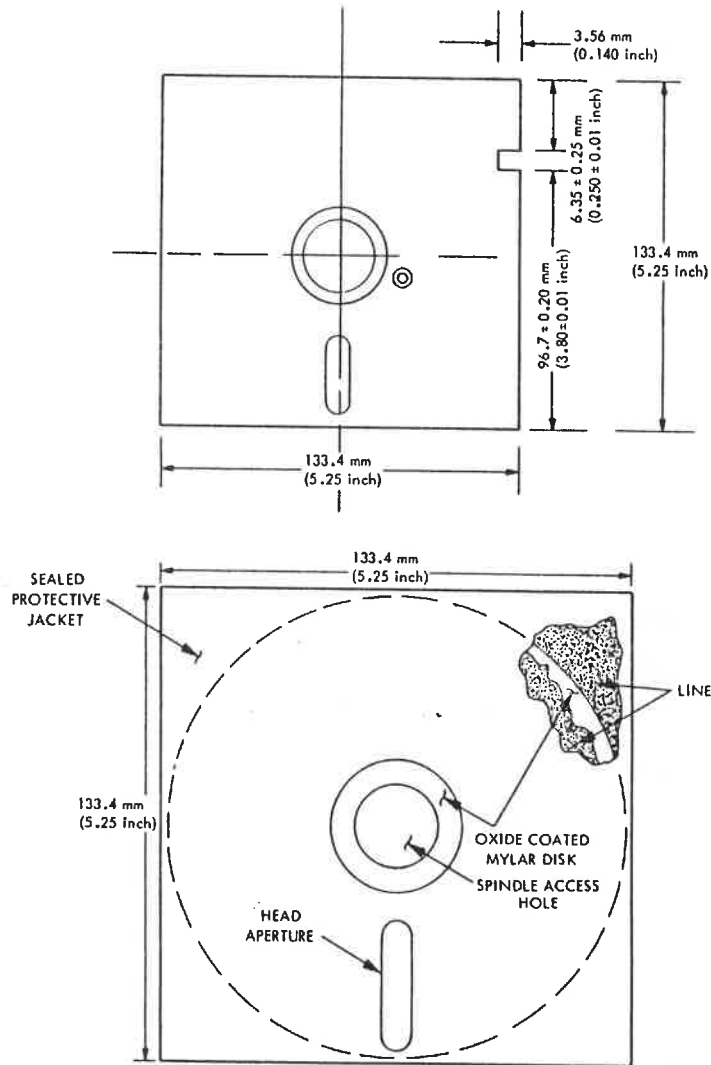

Figure 1-3. Recording Medium

Figure 1-4 provides some helpful hints on the care and handling of the disk drive and diskettes. Additionally, to assure trouble-free operation and enhance the service life of the diskette, the following procedures for handling should be observed.

- Return the diskette to the protective jacket when not in use.
- Store the diskette vertically; do not stack.
- Avoid exposing the diskette to any magnetizing force in excess of 400 A/m (50 oersted).

#### NOTE

The 400 A/m (50 oersted) level of magnetizing force is reached at a distance of approximately 76 mm (3 inches) from a typical source, e.g., motors, generators, transformers.

- Do not store the diskette in direct sunlight; warping could result.
- Do not use a lead pencil or ballpoint pen to write on the label; use a felt tip pen and mark lightly on the label.

### 1.15 LOADING THE DISKETTE

Diskette loading is accomplished by inserting the properly oriented diskette into the mail box type slot provided. Access to the diskette loading slot is obtained by opening the latch.

The diskette should be carefully inserted in the slot until the diskette jacket is solidly against the stops.

#### CAUTION

DAMAGE TO THE DRIVE HUB HOLE IN THE DISKETTE MAY RESULT IF THE LATCH IS CLOSED WHEN THE DISKETTE IS NOT PROPERLY INSERTED.

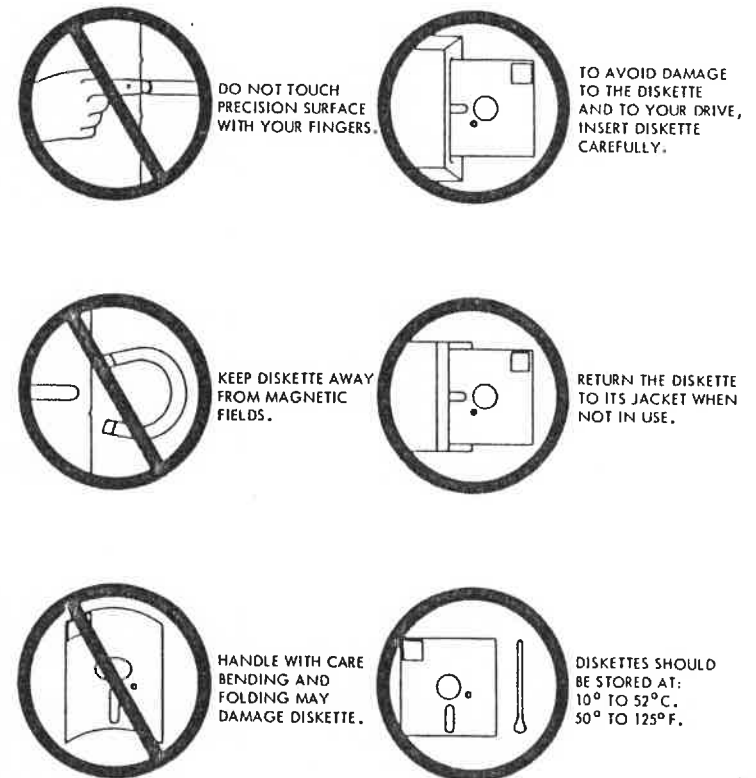

Figure 1-4. Diskette Care and Handling

### 1.16 WRITE PROTECT

The flexible disk drive is equipped with a write protect sensor assembly. This sensor operates in conjunction with a diskette having a slot cut in the protective jacket. The location of the slot is shown in Figure 1-5.

When the slot is covered, the diskette is write protected. The slot must be uncovered to write on the diskette. Figure 1-5 illustrates how to install a tab to cover the slot. (A write protect tab may be fabricated from an adhesive-backed label such as Avery #BSF-K1-S1608.)

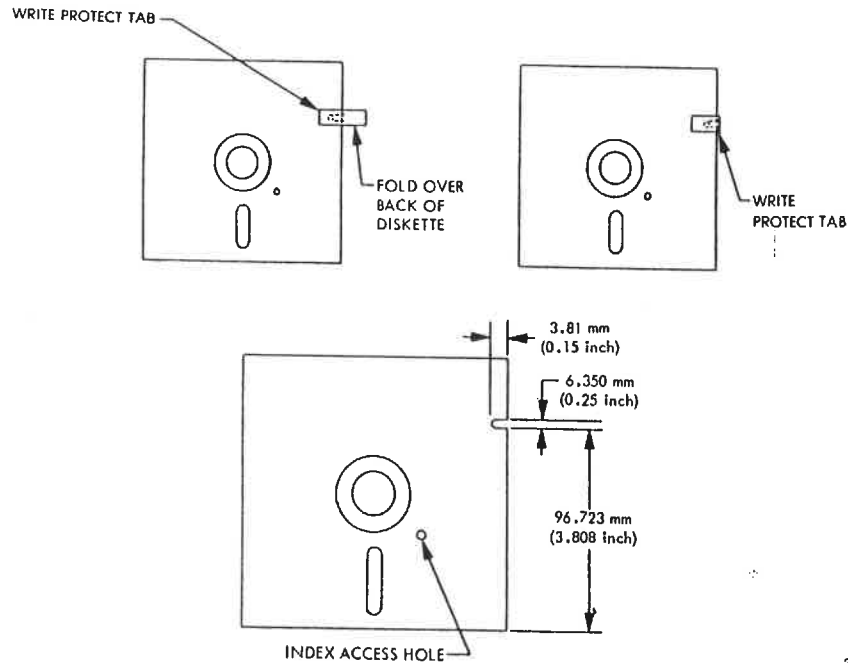

Figure 1-5. Write Protect Tab

3067

## SECTION II THEORY OF OPERATION

### 2.1 INTRODUCTION

This section provides a basic description of the operation of the PCC FD250 disk drive.

The flexible disk drive consists of the mechanical and electrical components necessary to record and read digital data on a diskette. User provided dc power at +12v, +5v is required for operation.

### 2.2 ORGANIZATION OF THE DISK DRIVE

All electrical subassemblies in the disk drive, except the magnetic heads, are constructed with leads which terminate in AMP push-in pins. These leads are merged and inserted in the 30-pin PCB connector body which interfaces with the single electronics PCBA in the drive. Thus, the individual assemblies can be removed without providing individual connectors with their associated space requirements on the PCBA.

The magnetic heads are connected to the PCBA via cables terminated in a 10-pin female connector and its associated male socket which is located in close proximity to the data electronics.

Interface signals and power are provided via connector(s) at the rear of the drive. Detailed description of these signals are presented in Section III.

### 2.3 FUNCTIONAL BLOCK DIAGRAM DESCRIPTION

Figure 2-1 is a functional block diagram of the FD250 disk drive and should be referred to in conjunction with the following discussion.

#### NOTE

*The identification of the elements in this discussion and the associated figures, although related to the actual schematic, are not exact. Total correspondence is not possible since the schematic contains functions which are only represented in simplified form in this section.*

The flexible disk drive consists of the following functional groups.

- (1) Head Load Driver
- (2) Index Pulse Shaper
- (3) Write Protect Sensor
- (4) Diskette In Place Sensor
- (5) Track 0 Switch
- (6) Spindle Drive Control
- (7) Positioner Control
- (8) Data Electronics

#### 2.3.1 HEAD LOAD DRIVER

The Head Load Driver consists of a head load solenoid driver and a Head Load Solenoid. The logic may be configured to cause the head to load via the DRIVE MOTOR ENABLE interface line or the UNIT SELECT interface lines. A true level on the appropriate interface line causes the Head Load Solenoid to energize. This action loads the upper head against the surface of the disk causing the recording surface to conform to the Write/Read Head. The upper head is lifted from the media when the access door is opened.

#### 2.3.2 INDEX PULSE SHAPER

An index pulse is provided to the user system via the INDEX PULSE interface line. The index circuitry consists of an index LED, an index phototransistor, and a pulse shaping network. As the index hole in the diskette passes the index LED/phototransistor combination, light from the LED strikes the index phototransistor causing it to conduct. The signal from the index phototransistor is passed to the index pulse shaper which produces a pulse for each hole detected. This pulse is presented to the user on the INDEX PULSE interface line.

#### 2.3.3 WRITE PROTECT

A Write Protect signal is provided to the user system via the WRITE PROTECT interface line. The write protect circuitry consists of a Write Protect Sensor and circuitry to route the produced signal.

When a write protected diskette is inserted in the drive, the sensor is closed and the logic disables the write electronics and supplies the status signal to the interface.

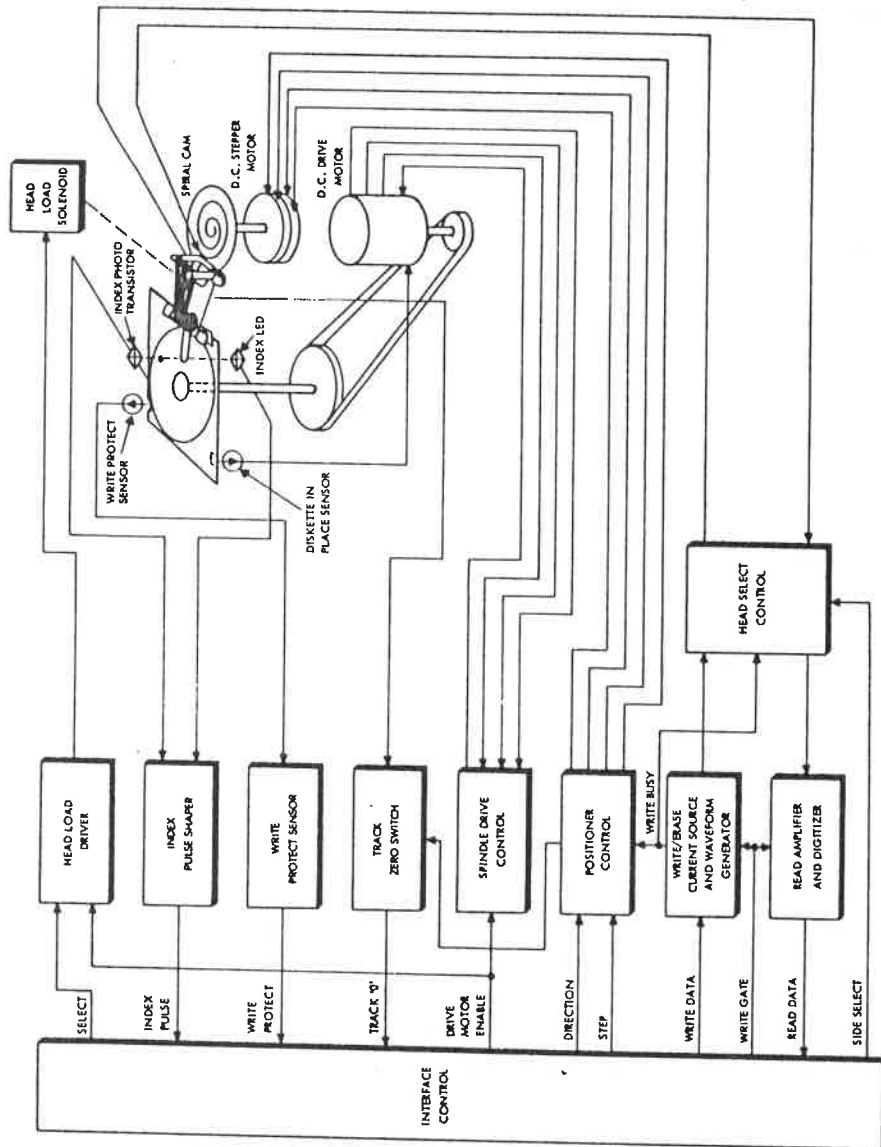

Figure 2-1. FD250 Functional Block Diagram

### 2.3.4 TRACK 0 SWITCH

The level on the TRACK 0 interface line is a function of the magnetic head assembly. When the heads are positioned at Track 0 and the stepper motor is on the home position, a true level is generated and sent to the user system. The Track 0 latch is activated by the Track 0 switch and inhibits response to any further step out commands issued by the user.

### 2.3.5 SPINDLE DRIVE CONTROL

The Spindle Drive system consists of a spindle assembly belt-driven by a combination dc motor-tachometer.

Associated with the spindle drive motor are the electronics required for control. Speed regulation is accomplished by a circuit which takes timing information from the tachometer, compares it to a reference time and generates a driving voltage proportional to the time difference.

The control circuitry also includes a current limiter and an interface control line. When the DRIVE MOTOR ENABLE interface line is true, the drive motor is allowed to come up to speed. When the current through the drive motor exceeds one ampere, the current limit circuitry disables the motor drive.

### 2.3.6 POSITIONER CONTROL

The head positioning system utilizes a four phase stepper motor driven through two phases for each track advancement of the Read/Write carriage. The positioner control circuit provides *home phase* pulses and *transient* pulses to generate the correct sequences of pulses for required stepper motor rotation. In addition to the steering logic necessary for motion control, a latch is provided as a memory element for inhibiting positioner motion during a write operation. If a step command has been issued during the write operation, the command will be executed upon completion of the write operation.

### 2.3.7 DATA ELECTRONICS

Information is normally recorded on the diskette in a single density code. Figure 2-2 illustrates the magnetization profiles in each bit cell for the number sequence shown.

The erase gaps serve to trim the recorded track from 0.330 to 0.305 mm (0.013 inch to 0.012 inch) and also provide an erased guard band on either side of the recorded track. This provides for tolerances in track positioning.

All signals required to control the data electronics are provided by the user system and are shown in the block diagram, Figure 2-1. These control signals are:

- SIDE SELECT
- WRITE GATE
- WRITE DATA
- READ DATA

The READ DATA composite signal is sent to the user system via the interface.

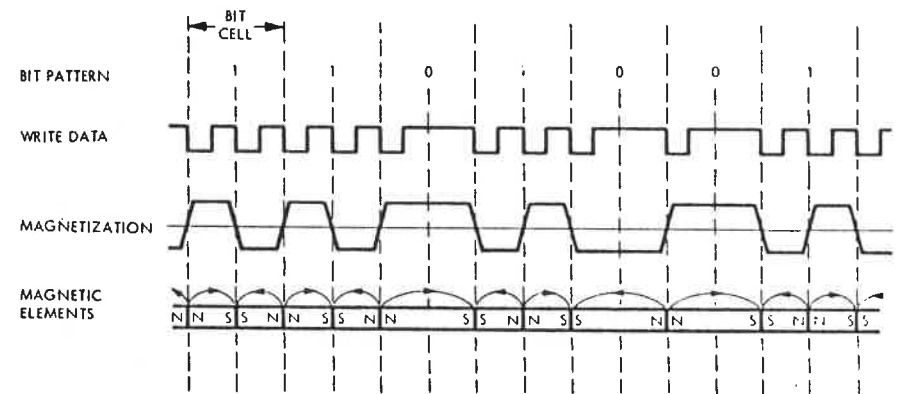

Figure 2-2. Single Density Recording



### 2.3.7.1 Data Recording

Referring to Figure 2-1, it can be seen that the Write Electronics consists of a Write/Erase Current Source and Write Waveform Generator, Erase Current Source, Trim Erase Control Logic, and logic to enable selection of the desired head.

The read/write winding on the magnetic head is center-tapped. During a write operation, current from the Write Current Source flows in alternate halves of the winding under control of the Write Waveform Generator.

Before recording can begin, certain conditions must be satisfied. The conditions required for recording (i.e., unit ready) must be established by the user system as follows.

- (1) Drive speed stabilization. This condition will exist 1 second after starting the drive motor.
- (2) Subsequent to any step operation, the positioner must be allowed to settle. This requires 10 msec after the last step pulse is initiated, i.e., 25 msec for the step motion and 10 msec for settling.
- (3) Subsequent to a Head Load operation, 35 msec is required for the head-media relationship to stabilize.
- (4) Subsequent to a change in the HEAD SELECT line, 100  $\mu$ sec is required for the Read Switch and Head Select circuitry to stabilize. Note that the Head Select logic prevents any change in the head being selected until after WRITE BUSY goes false. If the HEAD SELECT line is changed while WRITE BUSY is true, a 100  $\mu$ sec delay is required between the time WRITE BUSY goes false and the initiation of the recording process on the newly selected head.

#### NOTE

All of the foregoing operations can be overlapped, if required.

Figure 2-3 shows the relevant timing diagram for a write operation. At  $t = 0$  when the unit is ready, the WRITE GATE interface line goes true (Plot 1); this enables the Write Current Source.

Since the trim erase gaps are behind the read/write gap, the TRIM ERASE control goes true (Plot 2) 430  $\mu$ sec after the WRITE GATE interface line. It should be noted that this value is optimized between the requirements at Track 0 and Track 34 so that the encroachment by the trim erase gaps on previous information is minimized.

Plot 4 shows the information on the WRITE DATA interface line; Plot 5 shows the output of the Write Waveform Generator which toggles on the leading edge of every WRITE DATA pulse.

Note that Plot 4 indicates a minimum of 4  $\mu$ sec and a maximum of 8  $\mu$ sec between WRITE GATE going true and the first WRITE DATA pulse. This period is recommended only if faithful reproduction of the first WRITE DATA transition is significant.

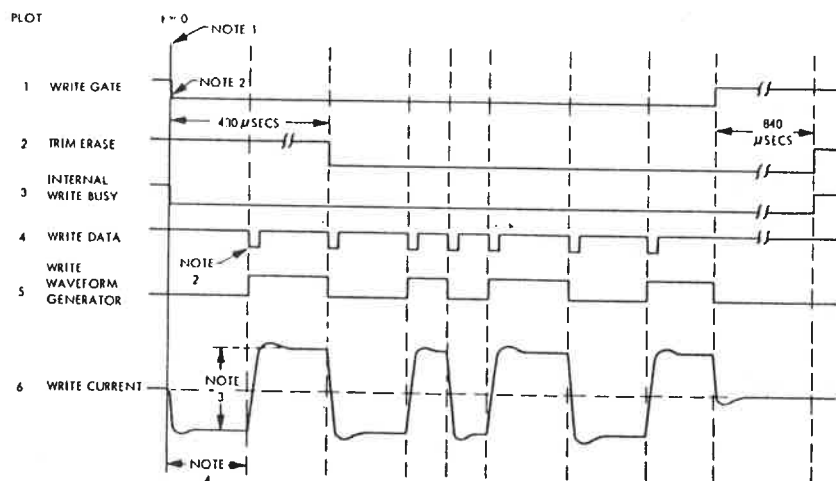

- NOTES: 1.  $t = 0 = 1$  SEC AFTER DRIVE MOTOR STARTS, OR 35 MSEC AFTER HEAD LOAD COMMAND, OR 35 MSEC AFTER LAST STEP PULSE, OR 100  $\mu$ SEC AFTER A CHANGE IN HEAD SELECT LINE AT A TIME WHEN WRITE BUSY WAS FALSE, OR 100  $\mu$ SEC AFTER WRITE BUSY GOES FALSE IF HEAD SELECT LINE WAS CHANGED WHILE WRITE BUSY WAS TRUE (WHICHEVER IS THE LATEST TIME)
- 2 UNSYNCHRONIZED
3. 8 MA PEAK TO PEAK
- 4 4  $\mu$ SECONDS MINIMUM, 8  $\mu$ SECONDS MAXIMUM

3254

Figure 2-3. Write Timing Diagram

At the end of recording, at least one additional pulse on the WRITE DATA line must be inserted after the last significant WRITE DATA to avoid excessive peak shift effects.

The TRIM ERASE signal (Plot 2) must remain true for 840  $\mu$ sec after the termination of WRITE GATE to ensure that all recorded data are trim erased. This value is again optimized between the requirements at Tracks 0 and 34.

The duration of a write operation is from the true-going edge of WRITE GATE to the false-going edge of TRIM ERASE. This is indicated by the internal WRITE BUSY waveform shown in Plot 3.

#### NOTE

Further information regarding format and control of the flexible disk is contained in a series of Application Notes, PCC Document Numbers 75605, 75607, and 76601.

### 2.3.7.2 Data Reproduction

- Read Switch and Head Select Control
- Read Amplifier
- Filter
- Differentiator
- Comparator and Digitizer

The read switch is used to isolate the Read Amplifier from the voltage excursions across the magnetic heads during a write operation. The switch is operated by the WRITE BUSY signal.

Before reading can begin, the drive must be in a ready condition. As with the data recording operation, this ready condition must be established by the user system. In addition to the requirements established in Paragraph 2.3.7.1, a 100  $\mu$ sec delay must exist from the trailing edge of the WRITE BUSY signal to allow the Read Amplifier to settle after the transient caused by the read switch returning to the Read mode.

Referring to Figure 2-4, the output signal from the read/write head is amplified by a *balanced-in/balanced-out* read amplifier and filtered to remove noise by a linear phase Filter. The linear output from the Filter (Plot 1) is passed to the Differentiator which generates a waveform (Plot 2) whose zero crossovers correspond to the peaks of the read signal (Plot 1). This signal is then fed to the Comparator and Digitizer circuit.

The Comparator and Digitizer circuitry generates a 1  $\mu$ sec READ DATA pulse (Plot 3) corresponding to each peak of the read signal.

This Composite Read Data signal is then sent to the user system via the READ DATA interface line.

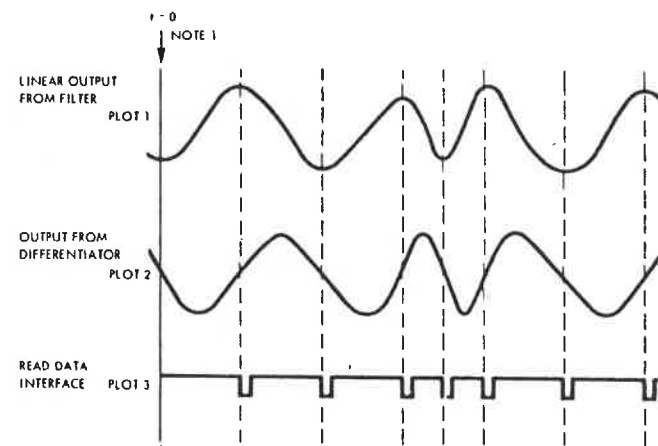

- NOTES: 1.  $t = 0 = 1$  SEC AFTER DRIVE MOTOR STARTS, OR 35 MSEC AFTER HEAD LOAD COMMAND, OR 35 MSEC AFTER STEP COMMAND, OR 100  $\mu$ SEC AFTER TERMINATION OF WRITE BUSY, OR 100  $\mu$ SEC AFTER SELECTING A DIFFERENT HEAD (WHICHEVER IS THE LATEST TIME)
2. 1  $\mu$ SEC PULSE WIDTH

3253

Figure 2-4. Read Timing Diagram

SECTION III  
OPERATION

3.1 INTRODUCTION

This section contains the interface description and the mechanical/electrical adjustments necessary for the FD250 Disk Drive.

3.2 PHYSICAL DESCRIPTION, PCBA NO. 600491

The PCBA is approximately 193 mm (7.6 inches) long by 130 mm (5.1 inches) wide. Figure 3-1 illustrates the placement of test points and connectors.

There are four connectors on the PCBA. J1 is the interface connector and is slotted to mate with a key in the mating plug; J2 is a 30-pin right angle connector into which the subassembly connector plugs; J3 is mounted on the reverse side to allow for dc power connections; J4, also mounted on the reverse side, is the connector into which the read/write head plugs.

3.3 INTERFACE ELECTRONICS SPECIFICATIONS

All interface signals are TTL compatible. Logic true (low) is at +0.4v (maximum), logic false (high) is +2.4v (minimum). Figure 3-2 illustrates the interface configuration.

It is recommended that the interface cable be twisted pairs, each with a characteristic impedance of 100 ohms (or equivalent) flat ribbon cable. Maximum interface cable length is 9.14 m (30 feet).

Interface connector pin assignments and power connector pin assignments are given in Tables 3-1 and 3-2, respectively.

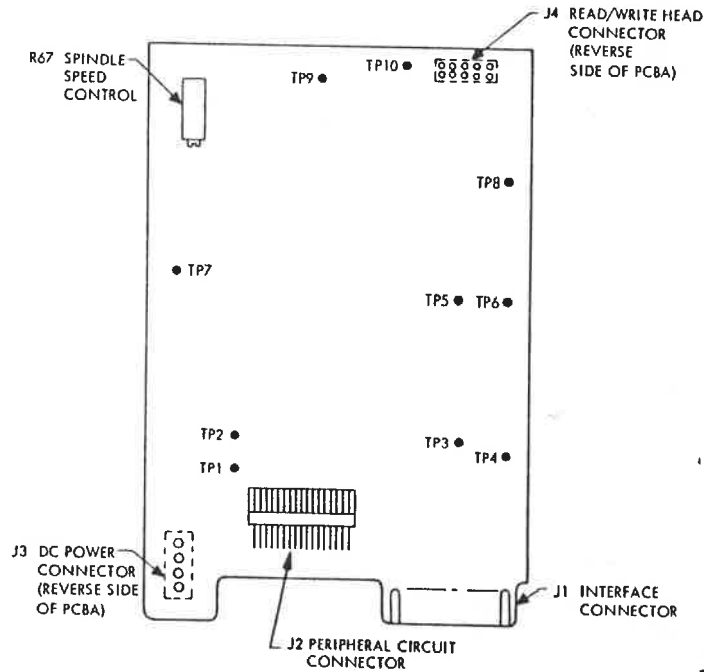
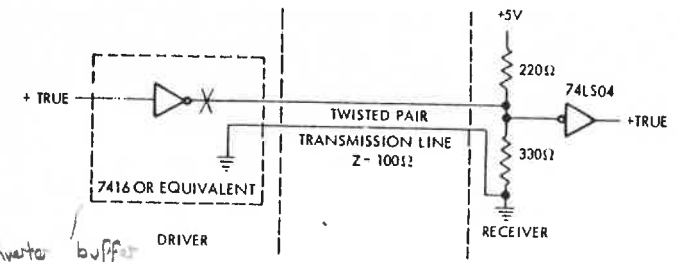

Figure 3-1. FD250 PCBA No. 600491, Test Point and Connector Placement

3251



hex inverter  
o/c  
buffer

Figure 3-2. Interface Configuration

1988

Table 3-1  
Interface Connector Pin Assignments, J1/P1

Controller-to-Disk Drive		
Ground	Signal	Description (Mnemonic)
1	2	(Spare)
3	4	(Spare) (IBSY Optional)
5	6	(Spare) (ISLT3 Optional)
9	10	SELECT 0 (ISLT0)
11	12	SELECT 1 (ISLT1)
13	14	SELECT 2 (ISLT2)
15	16	DRIVE-MOTOR ENABLE (IDEN)
17	18	DIRECTION (IDIR)*
19	20	STEP (ISTP)
21	22	WRITE DATA (IWDA)
23	24	WRITE GATE (IWGT)
31	32	SIDE SELECT (ISSLT)
Disk Drive-to-Controller		
7	8	INDEX (IINXP)
25	26	TRACK 0 (ITRK0)
27	28	WRITE PROTECT (IWPT)
29	30	READ DATA (IRDA)
33	34	(Spare)
*SIDE SELECT Optional		

Table 3-2  
Power Connector Pin Assignment, J3/P3

Pin	Power Supply
1	+ 12v dc
2	Return (+ 12v dc)
3	Return (+ 5v dc)
4	+ 5v dc

### 3.3.1 INPUT CONTROL LINES

#### 3.3.1.1 SELECT (ISLT0—ISLT3)

The SELECT lines provide a means of selecting and deselecting a disk drive. These four lines (ISLT0—ISLT3 standard; ISLT3 optional) select one of the four disk drives attached to the controller. When the signal logic level is true (low), the disk drive electronics are activated, the heads are loaded, and the drive is conditioned to respond to step or read/write commands. When the logic level is false (high), the input control lines and output status lines are disabled.

A SELECT line must remain stable in the true (low) state until the execution of a step or read/write command is completed.

The disk drive address is determined by a Select Switch on the PCBA. SELECT lines 0—3 provide a means of daisy-chaining a maximum of four disk drives to a controller. Only one line can be true (low) at a time. An undefined operation might result if two or more units are assigned the same address or if two or more SELECT lines are in the true (low) state simultaneously.

#### 3.3.1.2 DRIVE MOTOR ENABLE (IDEN)

When this signal line logic level goes true (low), the disk drive accelerates to its nominal speed of 300 rpm and stabilizes in less than 1 second. When the logic level goes false (high), the disk drive decelerates to a stop in less than 1 second.

#### 3.3.1.3 DIRECTION and STEP (2 Lines) (IDIR) (ISTP) (+ SIDE SELECT Optional)

When the disk drive is selected, a true (low) pulse with a time duration greater than 200 nsec, but less than 2 msec, on the STEP line initiates the access motion. The direction of motion is determined by the logic state of the DIRECTION line when a STEP pulse is issued. The motion is towards the center of the disk if the DIRECTION line is in the true (low) state when a STEP pulse is issued. The direction of motion is away from the center of the disk if the DIRECTION line is in the false (high) state when a STEP pulse is issued. To ensure proper positioning, the DIRECTION line should be stable 0.1  $\mu$ sec (minimum) before the trailing edge of the corresponding STEP pulse and remain stable until the trailing edge of the STEP pulse. The access motion is initiated on the trailing edge of the STEP pulse.

The direction line may additionally (at the option of the user) be used to select the lower or upper head as required. When this option is utilized, a true (low) state on this interface line causes the upper head (head 1) to be selected. A false (high) state causes the lower head (head 0) to be selected.

#### 3.3.1.4 SIDE SELECT (ISSLT)

A true (low) level on this interface line causes the upper head (head 1) to be selected for reading or writing. A false (high) level causes the lower head (head 0) to be selected.

#### 3.3.1.5 WRITE DATA (IWDA)

When the disk drive is selected, this interface line provides the bit-serial WRITE DATA pulses that control the switching of the write current in the head. The write electronics must be conditioned for writing by the WRITE GATE line (see Paragraph 3.3.1.6).

For each high-to-low transition on the WRITE DATA line, a flux change is produced at the write head gap. This causes a flux change to be stored on the medium.

A single density type encoding technique is used in which data and clock form the combined WRITE DATA signal. It is generally recommended that the repetition of the high-to-low transitions, when writing all 0s, be equal to the nominal data rate,  $\pm 0.1$  percent. The repetition rate of the high-to-low transitions, when writing all 1s, should be equal to twice the nominal data rate,  $\pm 0.1$  percent.

#### 3.3.1.6 WRITE GATE (IWGT)

When this signal is true (low), the write electronics are prepared for writing data (read electronics disabled). This signal turns on write current in the read/write head. Data is written under control of the WRITE DATA input line. It is generally recommended that changes of state on the WRITE GATE line occur before the first WRITE DATA pulse. However, the separation between the leading edge of WRITE GATE and the first significant WRITE DATA pulse should not be less than 4  $\mu$ sec and not greater than 8  $\mu$ sec. The same restrictions exist on the relationship between the least significant WRITE DATA pulse and the termination of the WRITE GATE signal. When the WRITE GATE line is false (high), all write electronics are disabled.

When a write-protected diskette is installed in a FD250 Disk Drive, the write electronics are disabled irrespective of the state of the WRITE GATE line.

#### 3.3.1.7 BUSY (IBSY) (Optional)

The BUSY interface line can (at the option of the user) may be used to turn on the BUSY INDICATOR LED. If this option is installed, a true (low) level on this interface line turns the LED on and a false (high) level turns it off.

### 3.3.2 OUTPUT STATUS LINES

#### 3.3.2.1 INDEX (IINXP)

The INDEX signal is provided once each revolution (200 msec, nominal) to indicate to the controller the beginning of a track. The INDEX line remains in the true (low) state for the duration of the INDEX pulse. The duration of an INDEX pulse is nominally  $4.0 \pm 1.0$  msec.

The leading edge of an INDEX pulse must always be used to ensure diskette interchangeability between PCC disk drives.

#### 3.3.2.2 TRACK-0 (ITRK0)

When the disk drive is selected, the TRACK-0 interface signal indicates to the controller that the read/write head is positioned at track 0. The TRACK-0 signal remains true (low) until the head is moved away from track 0.

#### 3.3.2.3 WRITE PROTECT (IWPT)

When the disk drive is selected, this signal line logic goes true (low) when the diskette is write protected. The write electronics are internally disabled when the diskette is write protected.

When the level on this line is false (high), the write electronics are enabled and the write operation can be performed. It is generally recommended that the controller not issue a write command when the WRITE PROTECT signal is true (low).

#### 3.3.2.4 READ DATA (IRDA)

This interface line transmits the readback data to the controller when the drive is selected. It provides a pulse for each flux transition recorded on the medium. The READ DATA output line goes true (low) for a duration of  $1 \pm 0.2$   $\mu$ sec for each flux change recorded.

The leading edge of the READ DATA output pulse represents the true positions of the flux transitions on the diskette surface.

## 3.4 CIRCUIT BOARD TEST POINTS

The following test point descriptions assume that the PCBA is installed in a FD250 Flexible Disk Drive and that the drive is in an operational mode with a diskette installed.

#### 3.4.1 LOGIC GROUND (TP1)

A digital logic ground reference point is provided near the I/O Connector.

#### 3.4.2 DIFFERENTIATED READ SIGNAL (TP3, TP4)

Unit is in the operational mode with diskette installed, head loaded and positioned at track 0. The differential amplitude of this signal when reading an all 1s (2F) pattern should be 3v peak-to-peak (nominal value, slide 0).

#### 3.4.3 READ DATA SINGLE SHOT (TP9)

The output of the single shot used in the read section is nominally  $1.0 \pm 0.2$   $\mu$ sec for each flux transition detected.

#### 3.4.4 INDEX PULSE (TP2)

With a standard diskette installed, the signal is a high-going pulse nominally 4.0 msec in duration every 200 msec.

#### 3.4.5 AMPLIFIED READ SIGNAL (TP5, TP6)

These test points are provided to observe the differential output of the first stage of read signal amplification.

#### 3.4.6 WRITE GATE (TP7)

This signal is the gated WRITE GATE interface line.

#### 3.4.7 ANALOG GROUND (TP8)

Analog ground reference point is provided when measuring read/write waveforms.

#### 3.4.8 TRIM ERASE DRIVER (TP10)

Output of the trim erase drive transistor.

### 3.5 OPTION SELECT

This section describes each jumper, etch cut, switch position and the related option.

#### 3.5.1 HEAD LOAD WITH SELECT

The standard configuration allows the head to be loaded with the SELECT line.

### 3.5.2 HEAD LOAD WITH DRIVE MOTOR ENABLE

The head may be loaded with the DRIVE MOTOR ENABLE interface line. To utilize this option, cut etch HL and add jumper DL.

### 3.5.3 SPINDLE DRIVE ENABLE WITH DISKETTE IN PLACE AND DRIVE MOTOR ENABLE

The standard configuration allows the spindle to turn with the DRIVE MOTOR ENABLE line and then only when a diskette is installed.

### 3.5.4 SPINDLE DRIVE ENABLE WITH DRIVE MOTOR ENABLE

With this option, the spindle is allowed to turn with the DRIVE MOTOR ENABLE line without regard to whether or not a diskette is installed. To utilize this option, add jumper DP.

### 3.5.5 BUSY INDICATOR WITH SELECT

The standard configuration allows the BUSY INDICATOR LED to be activated with the SELECT line.

### 3.5.6 BUSY INDICATOR WITH BUSY

The BUSY INDICATOR LED may be activated from the BUSY interface line. To utilize this option, cut etch HB and add jumper IB.

### 3.5.7 HEAD SELECTION WITH HEAD SELECT

The standard configuration allows the desired head to be selected with the HEAD SELECT interface line.

### 3.5.8 HEAD SELECTION WITH DIRECTION SELECT

The desired head may be selected with the direction select line. To utilize this option, cut etch IS and add Jumper DH.

### 3.5.9 SELECT SWITCH, S1

This Select Switch Array provides address selection for unit position. The switch positions should be exclusive, i.e., only one position active at a time. The following list specifies unit select via switch position. Etch DC on the component side of the PCBA must be cut to enable operation of the Select Switch.

S1-1	Select 0
S1-2	Select 1
S1-3	Select 2
S1-4	Select 3

## 3.6 MAINTENANCE PHILOSOPHY

To ensure that the disk drive operates at its optimum design potential, the only scheduled preventive maintenance required is periodic cleaning of the magnetic recording heads.

Mechanical and electrical adjustment details are provided for the case where further service is required as a result of disassembly or repair.

### 3.6.1 CLEANING THE HEADS

To clean the magnetic heads, use a lint-free cloth or cotton swab moistened with 91% Isopropyl alcohol. Wipe the heads carefully to remove all accumulated oxide and dirt. Dry the head using a lint-free cloth.

#### CAUTION

*ROUGH OR ABRASIVE CLOTH SHOULD NOT BE USED TO CLEAN THE MAGNETIC RECORDING HEADS. USE ONLY 91% ISOPROPYL ALCOHOL. USE OF OTHER CLEANING SOLVENTS, SUCH AS CARBON TETRACHLORIDE, MAY DAMAGE THE HEAD LAMINATION ADHESIVE.*

## 3.7 ADJUSTMENT

### 3.7.1 DRIVE MOTOR SPEED

- (1) Apply necessary power and control to turn on the drive.
- (2) Insert soft-sectored diskette.
- (3) Ensure that Drive Motor Enable line is active.
- (4) With counter-timer connected to Index Pulse (TP2), measure the duration of Index to Index pulse.
- (5) Adjust Speed Control potentiometer R67 until Index duration is 200 msec  $\pm$  3 msec.

## 3.7.2 CE ALIGNMENT

The CE alignment procedure locates the magnetic read/write head at the proper radial distance from the hub centerline, thus assuring accurate track location. This adjustment is necessary only after service, or for suspected diskette interchange problems.

### 3.7.2.1 Disk Drive Preparation

- (1) Manually rotate the stepper motor cam until the carriage is positioned at Track 0.
- (2) Apply the necessary power and control to turn on the disk drive.
- (3) Insert a CE Alignment Diskette (PCC Part No. 522-0250) into the drive and close the loading door.
- (4) Attach oscilloscope signal probes to test points TP3 and TP4; place ground clips of signal probes to TP8. Adjust the oscilloscope to read differentially (A + B with B inverted). Sync the oscilloscope on the leading edge of the Index pulse at TP2 with sync probe ground clip at TP1.

### 3.7.2.2 Radial Track Alignment

- (1) Load magnetic heads.
- (2) Select the lower head.

#### NOTE

*The physical relationship of the upper head to the lower head is accurately set during manufacture and is not field adjustable. If the lower head is accurately aligned and upper head misalignment is suspected, the drive must be returned to manufacturer for verification and subsequent repair.*

- (3) Perform 16 Step-In commands. The carriage will move to Track 16 (approximately).
- (4) Loosen the two stepper motor retaining screws on bottom of chassis.
- (5) Manually rotate stepper motor until the cats-eye pattern shown in Figure 3-3 is observed. Carefully rotate stepper motor until the cats-eye pattern has equal amplitudes (one lobe being 80 percent of the other is the acceptable limit).
- (6) Secure the stepper motor by tightening the retaining screws. Torque the two screws 9 to 11 in-lb.
- (7) After securing the stepper motor screws, verify Step (5). Repeat as required.

### 3.7.2.3 Index Sensor Alignment

- (1) Position index sensor (located on Clamp Support Beam) to center of travel; lightly tighten retaining screws.
- (2) Load magnetic heads.
- (3) Perform CE alignment as required to locate the cats-eye pattern at Track 16 (refer to Paragraph 3.7.2.2).
- (4) Perform 15 repetitive Step-Out commands to position the carriage at Track 01.
- (5) Set oscilloscope horizontal time base to 20  $\mu$ sec per division.
- (6) Referring to Figure 3-4, adjust phototransistor mounting block until the first transition of the 2 msec burst recorded at Track 01 occurs 200  $\pm$  100  $\mu$ sec after the leading edge of the index pulse. Adjustment may be made with the use of a flat-bladed screwdriver placed between the phototransistor mounting block and Clamp Support Beam cavity as required.

#### NOTE

*Care should be taken to avoid breakage of the web of the Clamp Support Beam forward of the phototransistor mounting block during adjustment.*

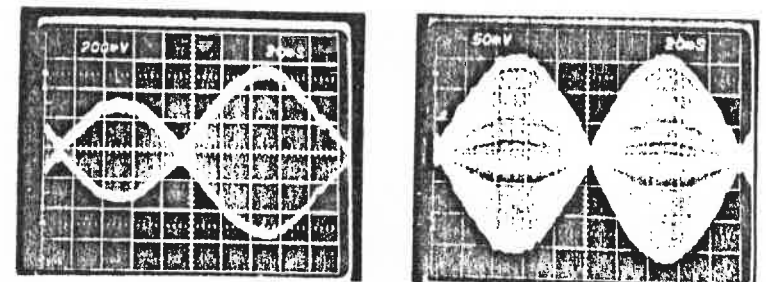

OFF TRACK INDICATION

ON TRACK INDICATION

3098

Figure 3-3. Cats Eye Pattern

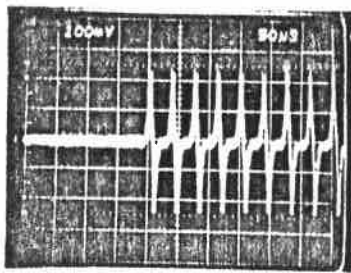

3099

Figure 3-4. Index to Data Burst

- (7) Secure retaining screws on the phototransistor mounting blocks and verify burst location; readjust as necessary.
- (8) Verify the cats-eye pattern at Track 16.

### 3.7.3 TRACK ZERO SWITCH

- (1) Apply the necessary power and control to turn on the drive.
- (2) Insert CE Alignment Diskette (PCC Part No. 522-0250) into the drive and close the loading door.
- (3) Load magnetic head.
- (4) Position the carriage to Track 16. Confirm the Track 16 position by observing the cats-eye pattern. Position the carriage to Track 01.
- (5) Loosen the two retaining screws of the Track 0 bracket.
- (6) Adjust the Track 0 switch bracket so that the switch is closed when the carriage is positioned at Track 01 and open at Track 02. Secure the two retaining screws.

### 3.7.4 WRITE PROTECT SWITCH

- (1) Insert diskette to within 1.016 mm (0.040 inch) of diskette stop.
- (2) Ensure that the switch is actuated.
- (3) Insert diskette fully against diskette stop and close the loading door.
- (4) Adjust switch by loosening retaining screws and setting sense arm in center of notch.

### 3.7.5 DISKETTE IN PLACE SWITCH

- (1) Insert diskette until it engages the switch actuator.
- (2) Ensure that the switch is actuated.
- (3) Remove the diskette and ensure that the switch is not actuated.
- (4) If conditions in (2) and (3) are not met, loosen the switch retaining screws and adjust switch.
- (5) Ensure that conditions in (2) and (3) are satisfied and repeat adjustment if necessary.

## SECTION IV PARTS LISTS AND SCHEMATIC/ASSEMBLY DRAWINGS

### 4.1 INTRODUCTION

This section contains the illustrated parts lists, recommended spare parts lists, and schematic/assembly drawings.

### 4.2 ILLUSTRATED PARTS BREAKDOWN (IPB)

Figures 4-1, 4-2 and 4-3, used in conjunction with Tables 4-1, 4-2 and 4-3, respectively, provide identification, by PCC PD part number, of the mechanical and electrical components of the FD250 Flexible Disk Drive. Notations are made when parts do not apply to all model configurations.

### 4.3 RECOMMENDED SPARE PARTS

Table 4-4 provides a list of the recommended spare parts. The customer should always furnish model and serial number of the Disk Drive when ordering parts.

An additional recommended spare parts list containing the part number, description, current price for component parts, subassembly parts, and special tools is also available. This list can be obtained by providing the unit part number from the ID label on the Disk Drive to Spares Product Management, Perdec Computer Corporation, Peripherals Division, 9600 Irondale Avenue, Chatsworth, CA 91311.

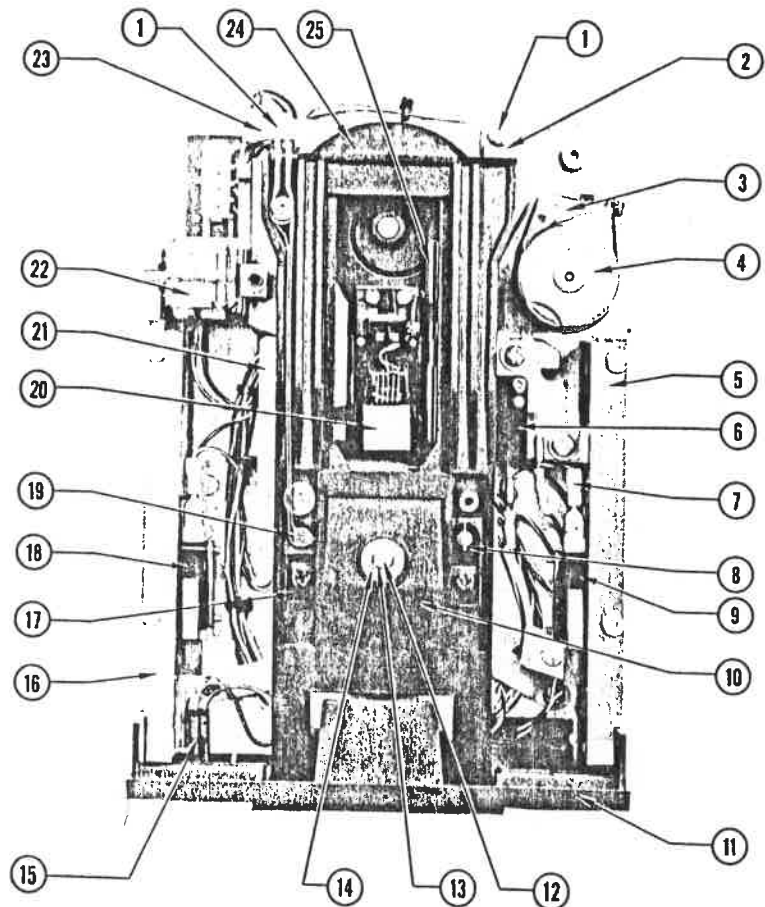

7110

Figure 4-1. FD250, Top View

Table 4-1  
FD250 Photo Parts Index

Figure & Index No.	Part No.	Description
Figure 4-1		
1	608-0607	Screw (21 places)
2	600430-01	Spring, Clamp Support Beam (2 places)
3	102245-01	RFI Filter Assembly
4	500-0010 600-0608	DC Motor With AC Tachometer Screw (2 required)
5	600482-02 608-0607	Cartridge Guide (right) Screw (2 required)
6	600438-01 608-0607 606-0600 506-9204	Track 0 Switch Assembly with Bracket Screw (2 required) Washer (2 required) Switch Only
7	656-0044	Push-on Terminal (7 places)
8	600421-01 608-0607	LED Mount Screw
9	600446-02 600-0412 506-9205	Diskette In Place Sensor Screw (2 required) Switch Only
10	600489-01	Clamp Support Beam
11	600415-01 607-0605	Bezel Screw (4 required)
12	600448-01	Clamp Support Shaft
13	611-0022	Retaining Ring (2 required, top and bottom of beam)
14	612-0004	Shim
15	600462-01 600469-01 509-0010	Diode Connector Assembly Diode Lens
16	600482-01 608-0607	Cartridge Guide (left) Screw
17	600502-01 608-0607 301-5455	Index LED Assembly (partially shown) Screw LED Only
18	600446-01 600-0412 506-9205	Write Protect Assembly Screw (2 required) Switch Only
19	600503-01 608-0605	Index Phototransistor Assembly Screw
20	526-0250	Carriage Head Assembly
21	600440-02	Spring, Carriage Guide Rail
22	600488-01 608-0607 502-0200	Head Load Actuator Assembly Screw Relay Only
23	661-0020	Clamp
24	600418-01	Positioner Cam
25	600432-01	Carriage Shaft
Not Shown	600461-01 616-7206 600417-01 600419-01 600462-01	Compliant Clamp Assembly Compression Spring Lever Door Pivot Shaft Hub Assembly With Shaft

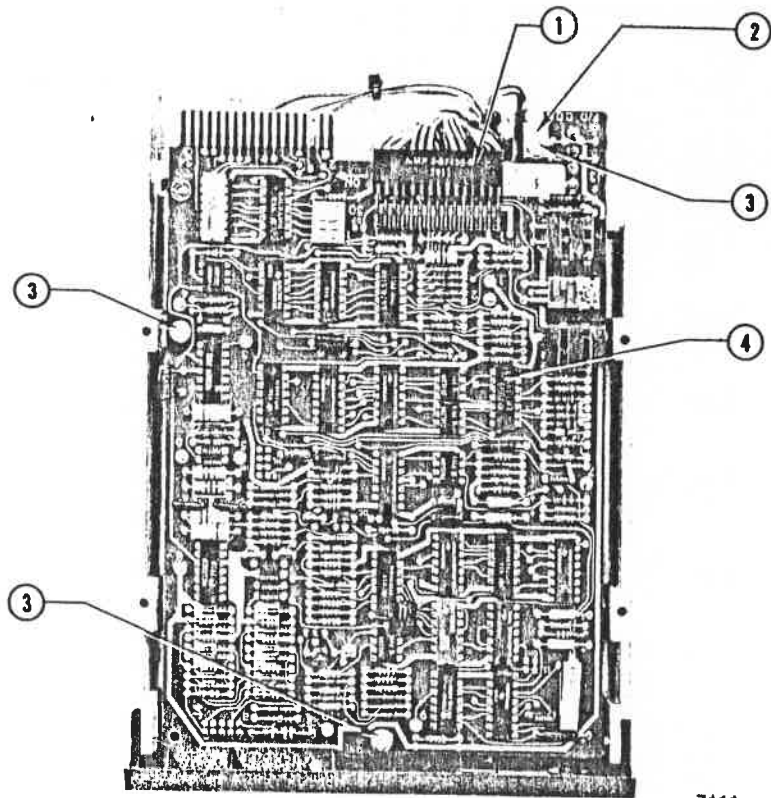

Figure 4-2. FD250, Bottom View

7111

Table 4-2  
FD250 Photo Parts Index

Figure & Index No.	Part No.	Description
Figure 4-2		
1	503-0142	Connector Housing
2	657-0002	Terminal
3	608-0607	Screw
4	600491.*	PCBA FD Control J

\*Order as indicated on PCBA, component side.

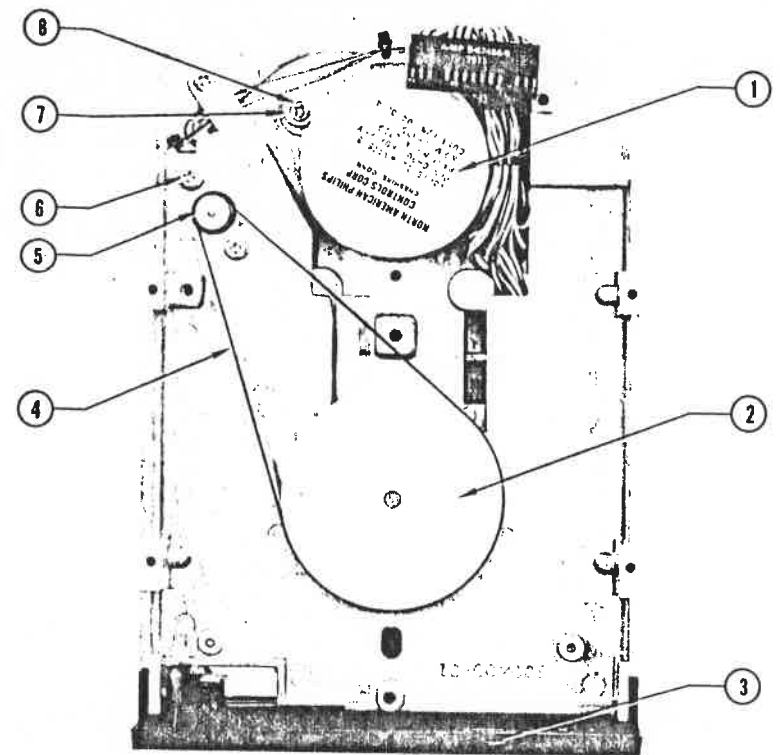

Figure 4-3. FD250 Bottom View, PCBA Removed

7112

Table 4-3  
FD200/FD250 Photo Parts Index

Figure & Index No.	Part No.	Description
Figure 4-3		
1	504-0004	Stepping Motor
2	600430-01	Drive Pulley
3	600415.*	Bezel
4	610-0022	Drive Belt
5	500-0010	Part of DC Motor
6	600-0608	Screw
7	600443-01	Mounting Cleat
8	600-0607	Screw

\*Order as indicated on bezel.



DENOTES PIN NO. 1

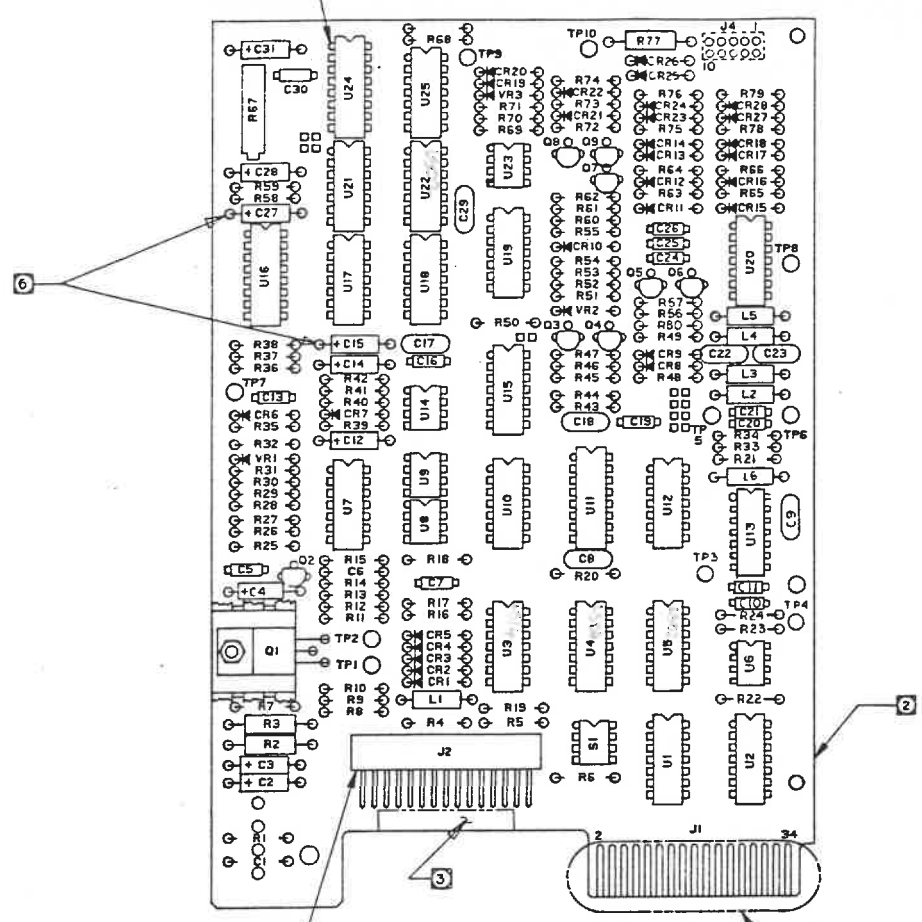

U2 is resistor

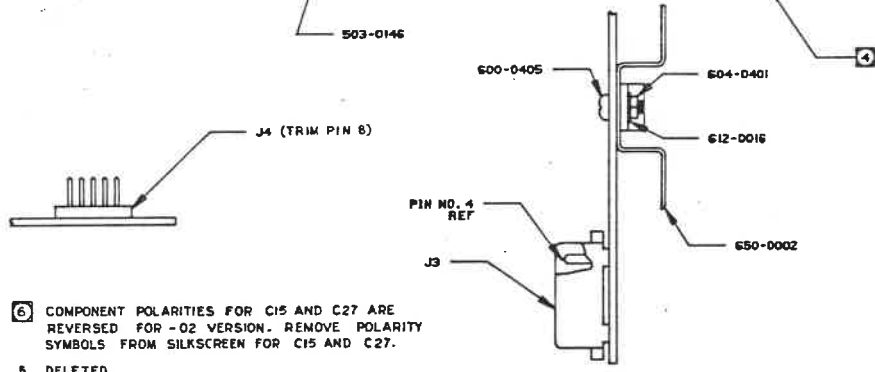

- 6 COMPONENT POLARITIES FOR C15 AND C27 ARE REVERSED FOR -02 VERSION. REMOVE POLARITY SYMBOLS FROM SILKSCREEN FOR C15 AND C27.
- 5. DELETED
- 4 MASK AREAS SHOWN DURING FLOW SOLDER OPERATION.
- 3. MARK VERSION NUMBER AND VERSION ISSUE LETTER IN AREA SHOWN.
- 2 THIS ASSEMBLY SHALL BE MADE FROM PROCESS BOARD 600492-01 REV B. AND SUBSEQUENT.
- 1. ASSEMBLE PER STANDARD MANUFACTURING METHODS.

NOTES: UNLESS OTHERWISE SPECIFIED

<b>PERTEC</b> <small>a member of Perkin-Elmer Corporation</small>		
TITLE <b>PCBA, FD CONTROL J</b>		
SIZE E	ISSUE NO. 32097	DRWG NO. 600491
		REV E

1



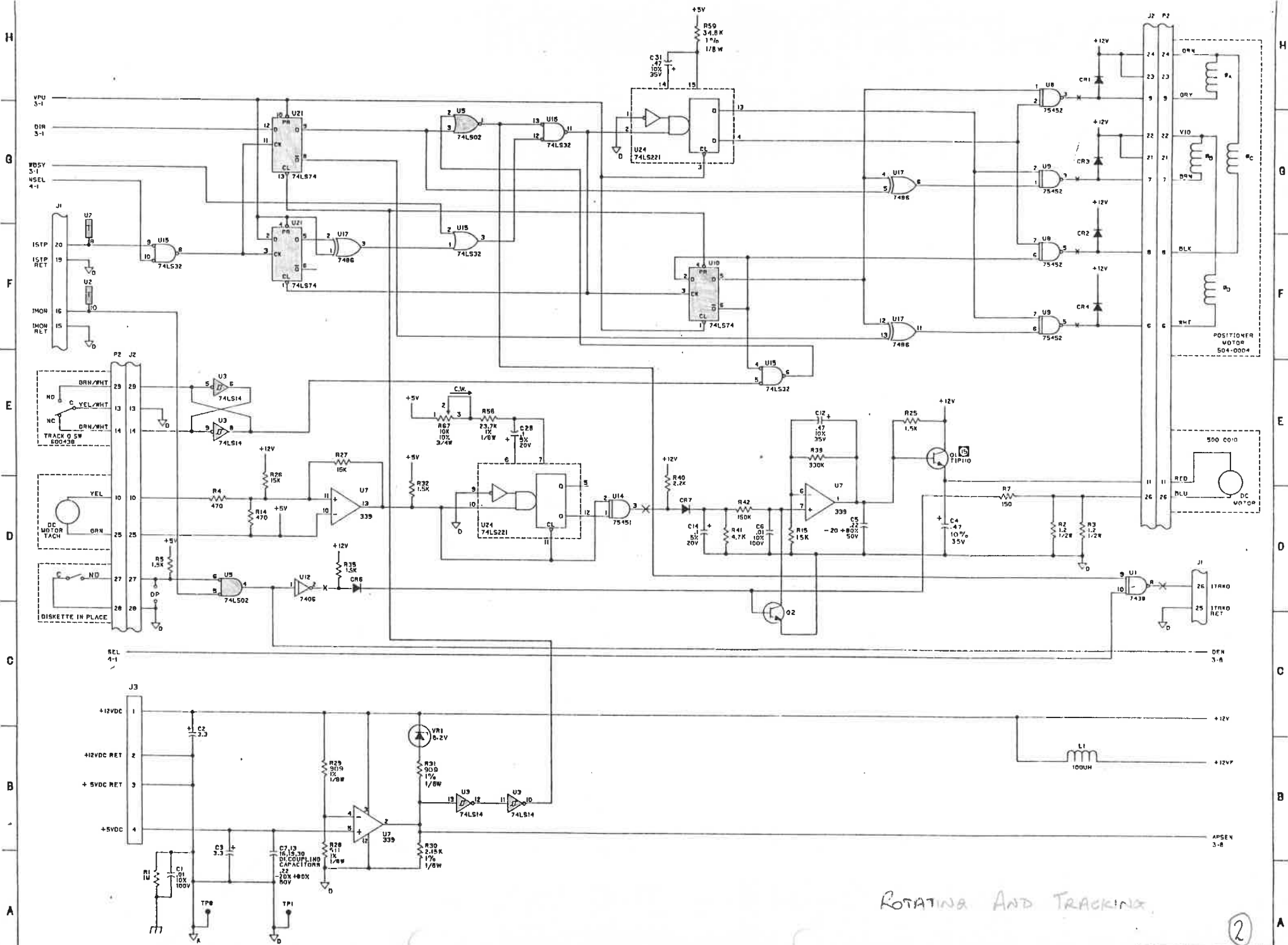

ROTATING AND TRACKING

2

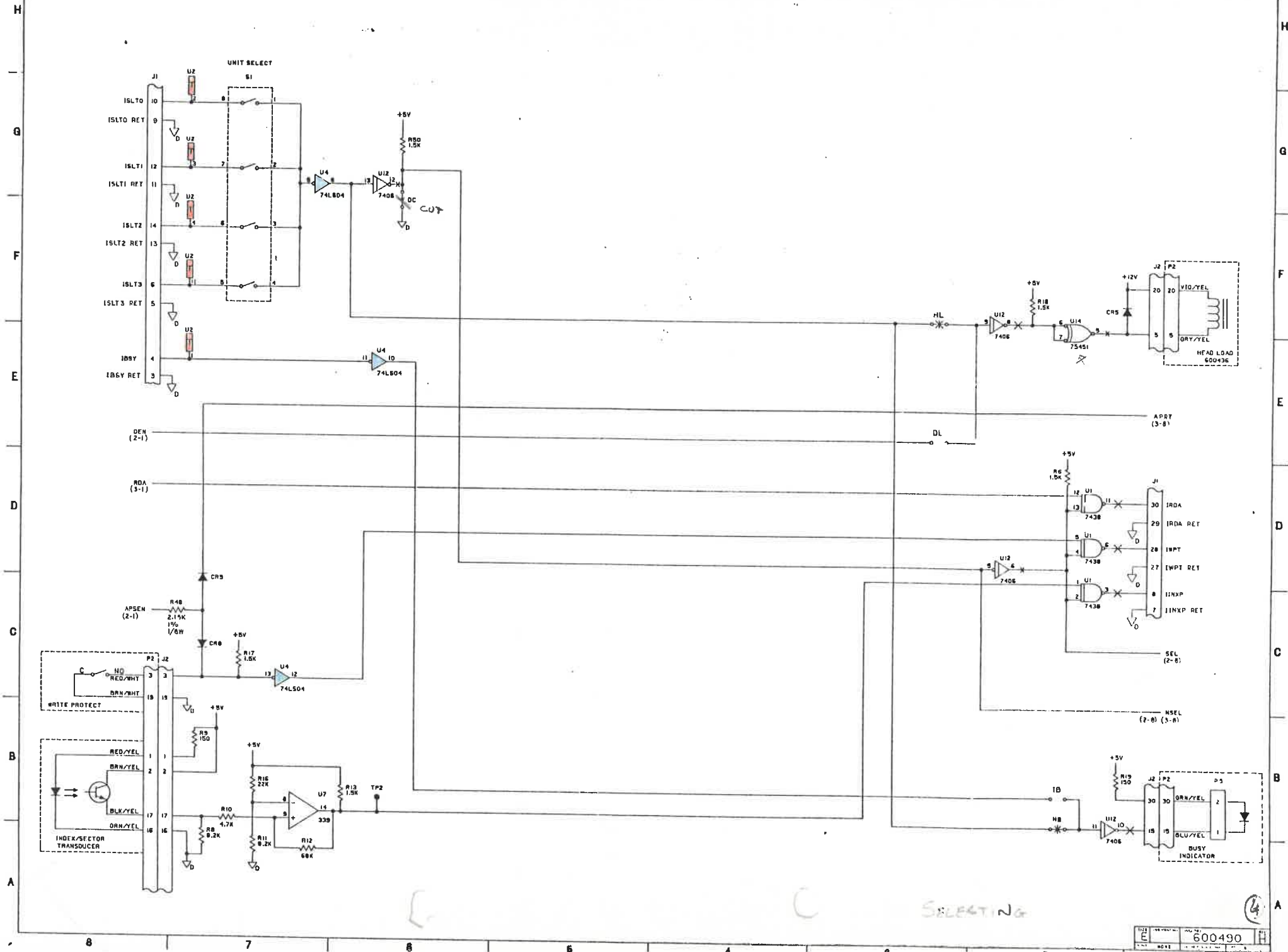

SELECTING

write

read amplifiers

lower

upper

write trim

read data recovery

READING AND WRITING

