

# **FD1165**

## **Flexible Disk Drive Maintenance Manual**

**NEC**

**NEC Information Systems, Inc.**

819-000090-2001  
10-82

## LIABILITY DISCLAIMER

NEC Information Systems, Inc. products are warranted in accordance with the terms of the applicable NEC Information Systems, Inc. product specification. Product performance is affected by system configuration, software, the application, customer data and operator control of the system among other factors. While NECIS products are considered to be compatible with most systems, the specific functional implementation by customers of the product may vary.

Therefore, the suitability of a product for a specific application must be determined by the customer and is not warranted by NECIS.

This manual is as complete and factual as possible at the time of printing, however, the information in this manual may have been updated since that time. NEC Information Systems, Inc. reserves the right to change the functions, features, or specifications of its products at any time, without notice.

NEC Information Systems, Inc. has prepared this document for use by NECIS employees and customers. The information contained herein is the property of NECIS and shall not be reproduced in whole or in part without prior written approval from NECIS.

First Printing - October 1982

Copyright 1982<sup>©</sup>  
NEC Information Systems, Inc.  
5 Militia Drive  
Lexington, MA 02173

Printed in U.S.A.

FEDERAL COMMUNICATIONS COMMISSION RADIO FREQUENCY  
INTERFERENCE STATEMENT

Although disk drives as subsystem type components do not require FCC rating, the following statement applies to the Model FD1165.

This unit has been type tested and found to comply with the limits for a Class B computing device in accordance with the specifications for Subpart J of Part 15 of FCC Rules, which are designed to provide reasonable protection against such interference in a residential installation.

Manufacturer's Instructions and User's Responsibilities  
to Prevent Radio Frequency Interference

Manufacturer's Instructions

The user must observe the following precautions in installing and operating this device:

1. Operate the equipment in strict accordance with the manufacturer's instructions for the model.
2. Ensure that the unit is plugged into a properly grounded wall outlet and that the power cord supplied with the unit is used and not modified.
3. Ensure that the unit is always operated with the factory installed cover set on the unit.
4. Make no modification to the equipment which would affect its meeting the specified limits of the Rules.
5. Properly maintain the equipment in a satisfactory state of repair.

## User's Responsibility

The user has the ultimate responsibility to correct problems arising from harmful radio-frequency emissions from equipment under his control. If this equipment does cause interference to radio or television reception, which can be determined by turning the equipment off and on, the user is encouraged to try to correct the interference by one of the following measures. All of these responsibilities and any others not mentioned are exclusively at the expense of the user.

1. Change in orientation of the receiving device antenna.
2. Change in orientation of the equipment.
3. Change in location of equipment.
4. Change in equipment power source.

If these attempts are unsuccessful, install one or all of the following devices:

1. Line isolation transformers
2. Line filters
3. Electro-magnetic shielding

If necessary, the user should consult the dealer, NEC or an experienced radio/television technician for additional suggestions. The user may find the following booklet prepared by the Federal Communications Commission to be helpful; "How to Identify and Resolve Radio-TV Interference Problems." This booklet is available from the U.S. Government Printing Office, Washington, D.C. 20402, Stock No. 004-000-00345-5.

"Note: The operator of a computing device may be required to stop operating his device upon finding that the device is causing harmful interference and it is in the public interest to stop operation until the interference problem has been corrected."

# CONTENTS

	<u>Page</u>
<b>CHAPTER 1 GENERAL INFORMATION</b>	
1.1	DESCRIPTION..... 1-1
1.2	CONSTRUCTION AND FEATURES..... 1-2
1.2.1	Base Frame..... 1-2
1.2.2	Spindle Assembly..... 1-2
1.2.3	Dc Direct Drive Spindle Motor..... 1-3
1.2.4	Carriage Read/Write Assembly Heads... 1-3
1.2.5	Stepping Motor..... 1-3
1.2.6	Head Load Cam Assembly..... 1-3
1.2.7	Pop-Up Feature..... 1-4
1.2.8	Index Sensor..... 1-4
1.2.9	00 Track Sensor..... 1-4
1.2.10	Write Protect Sensor..... 1-4
1.2.11	Media-In Sensor..... 1-4
1.2.12	Collet Assembly..... 1-4
1.2.13	Printed Circuit Board (PCB)..... 1-4
1.2.14	Variable Frequency Oscillator (Optional)..... 1-4
1.2.15	Display Lamps..... 1-5
1.2.16	Front Panel..... 1-5
1.2.17	Movable Door Handle..... 1-5
1.2.18	Door Lock Solenoid..... 1-5
1.3	SPECIFICATIONS..... 1-5
<b>CHAPTER 2 INSTALLATION AND OPERATION</b>	
2.1	PRELIMINARY INSPECTION..... 2-1
2.2	UNPACKING AND REPACKING..... 2-1
2.2.1	Unpacking Procedure..... 2-1
2.2.2	Repacking Procedure..... 2-1
2.2.3	Preinstallation Inspection..... 2-3
2.3	ENVIRONMENTAL REQUIREMENTS..... 2-3
2.3.1	Operating Environment..... 2-3
2.3.2	Space and Weight Data..... 2-3
2.3.3	Mounting..... 2-3

## CONTENTS (cont'd)

	<u>Page</u>
2.4 POWER SUPPLY.....	2-6
2.4.1 Power Supply Specifications.....	2-6
2.4.2 Power Connector.....	2-6
2.4.3 Power Connector Pin Assignments.....	2-7
2.5 INTERFACE CONNECTION.....	2-8
2.6 TERMINATOR RESISTORS.....	2-9
2.7 DRIVE IDENTIFICATION (DX) SELECTION.....	2-12
2.8 OPTION SELECTION.....	2-12
2.8.1 Head Load Jumper (HL).....	2-12
2.8.2 Radial Ready Jumper (RX).....	2-12
2.8.3 Side Select Jumper (SS).....	2-12
2.8.4 Write Protect Jumper (PR).....	2-13
2.8.5 File Unsafe Jumper (FR).....	2-13
2.8.6 Door Lock Jumpers (DL, DR, DH).....	2-13
2.8.6.1 DR Jumper.....	2-13
2.8.6.2 DL Jumper.....	2-13
2.8.6.3 DH Jumper.....	2-13
2.8.7 In Use Pins (US).....	2-14
2.8.8 Read Data Pins (RD).....	2-14
2.8.9 Busy Lamp Jumpers (BU, BS).....	2-14
2.8.9.1 Busy Lamp On During Head Load.....	2-14
2.8.9.2 Busy Lamp On During Drive Select.....	2-15
2.8.9.3 Busy Lamp On During In Use.....	2-15
2.9 OPERATING THE FD1165.....	2-15
2.9.1 Inserting a Flexible Disk.....	2-15
2.9.2 Removing a Flexible Disk.....	2-16
2.10 DISPLAY LAMPS.....	2-16
2.10.1 Ready Lamp.....	2-16
2.10.2 Busy Lamp.....	2-17

## CONTENTS (cont'd)

	<u>Page</u>
CHAPTER 3 INTERFACE INFORMATION	
3.1 BASIC OPERATIONAL DESCRIPTION.....	3-1
3.2 ELECTRICAL INTERFACE.....	3-2
3.2.1 Signal Levels.....	3-2
3.2.2 Driver/Receiver Circuits.....	3-2
3.2.3 Interface Lines.....	3-3
3.3 INPUT SIGNALS.....	3-3
3.3.1 Drive Select 1 Through 4 (DSX1 to 4).	3-3
3.3.2 Head Load (HDL).....	3-4
3.3.3 Step (STP).....	3-4
3.3.4 Direction Select (DIR).....	3-4
3.3.5 Side Select (SSL).....	3-4
3.3.6 Write Gate (WGT).....	3-5
3.3.7 Write Data (WDT).....	3-5
3.3.8 Low Write Current (LWC).....	3-5
3.3.9 File Unsafe Reset (FUR).....	3-6
3.3.10 In Use (USE).....	3-6
3.4 OUTPUT SIGNALS.....	3-6
3.4.1 Index (IDX).....	3-6
3.4.2 Track 00 (TK0).....	3-7
3.4.3 Dual-Sided (TSD).....	3-7
3.4.4 Ready (RDY).....	3-7
3.4.5 File Unsafe (FUS).....	3-7
3.4.6 Read Data (RDT).....	3-8
3.4.7 Write Protect (PRT).....	3-8
3.4.8 Disk Change (DCG).....	3-8
3.5 VFO INTERFACE SIGNALS.....	3-9
3.5.1 Modified Frequency Modulation Mode (MFM).....	3-9
3.5.2 VFO Synchronization (SYC).....	3-9
3.5.3 Standardized Read Data (SRD).....	3-9
3.5.4 Window (WID).....	3-9
3.6 INTERFACE TIMING.....	3-10
3.6.1 Power On Sequence.....	3-10
3.6.2 Drive Select.....	3-10
3.6.3 Step and Track 00.....	3-10
3.6.4 Access.....	3-11
3.6.5 Write.....	3-11
3.6.6 Read.....	3-12

## CONTENTS (cont'd)

	<u>Page</u>
CHAPTER 4 MAINTENANCE	
4.1	PREVENTIVE MAINTENANCE..... 4-1
4.2	MAINTENANCE TOOLS..... 4-1
4.3	MAINTENANCE PARTS..... 4-1
4.4	REMOVAL AND REPLACEMENT PROCEDURES..... 4-2
4.4.1	PCB Removal..... 4-2
4.4.2	Collet Assembly Removal, Replacement, and Adjustment..... 4-3
4.4.3	Carriage Assembly Removal and Replacement..... 4-6
4.4.4	Head Load Cam Assembly and Head Load Cam Removal and Replacement..... 4-8
4.4.5	Write Protect Sensor and Media-In Sensor Removal and Replacement..... 4-9
4.4.6	Optical Tachometer Sensor Removal and Replacement..... 4-10
4.4.7	Sensor Cable Assembly (LED Assembly and Index Sensor Removal and Replacement..... 4-11
4.4.8	Removing and Replacing the Carbon Brushes..... 4-14
4.4.9	Armature Removal..... 4-15
4.4.10	Spindle Assembly Removal..... 4-16
4.4.11	Front Panel Removal..... 4-17
4.4.12	Picker Rod Removal and Replacement... 4-17
4.4.13	Pop-Up Assembly Removal and Replacement..... 4-18
4.4.14	Guide Rail Removal..... 4-19
4.4.15	Checking the Operation of the Pop-Up Feature..... 4-19
4.4.16	Door Lock Solenoid Removal and Replacement..... 4-20
CHAPTER 5 ADJUSTMENTS	
5.1	DIAGNOSTIC TESTS..... 5-1
5.1.1	Auto Tap Test..... 5-2
5.1.2	Auto Seek Test..... 5-2
5.1.3	Auto Seek and Auto Tap Test..... 5-2
5.2	HEAD UNLOAD DELAY..... 5-2
5.3	TEST POINTS..... 5-3



## CONTENTS (cont'd)

	<u>Page</u>
5.4 ADJUSTMENTS AND CHECKS USING THE ALIGNMENT FLEXIBLE DISK.....	5-3
5.4.1 Head Radial Alignment Check or Adjustment.....	5-4
5.4.2 Azimuth Check.....	5-6
5.4.3 Index Alignment Check or Adjustment..	5-7
5.5 OTHER ADJUSTMENTS.....	5-8
5.5.1 LED Assembly/Index Assembly Check and Adjustment.....	5-8
5.5.2 00 Track Sensor Check or Adjustment..	5-9
5.5.3 Write Protect Sensor Check or Adjustment.....	5-10
5.5.4 Head Load Check.....	5-10
5.6 TRIM POTS.....	5-11
CHAPTER 6 ILLUSTRATED PARTS BREAKDOWN	
CHAPTER 7 SCHEMATIC	

## ILLUSTRATIONS

<u>Figure</u>	<u>Title</u>	<u>Page</u>
1-1	FD1165 Flexible Disk Drive.....	1-2
2-1	Unpacking.....	2-2
2-2	Model FD1165 Physical Dimensions.....	2-4
2-3	Vertical Installation.....	2-4
2-4	Horizontal Installation.....	2-4
2-5	On-End Installation.....	2-5
2-6	Air Flow Requirements for Natural Air Cooling.....	2-5
2-7	Power Connector Location.....	2-7
2-8	Pin and Line Assignments for the Power Connector.....	2-7
2-9	Contact Arrangement for Edge Connector.....	2-8
2-10	Interface Connector.....	2-8
2-11	Terminator Resistors and Jumper Locations on the PCB.....	2-10
2-12	Parallel and Series Configurations.....	2-11
2-13	Closing the Door of the FD1165.....	2-15
2-14	Unlocking the Door and Removing the Flexible Disk.....	2-16
3-1	Driver/Receiver Circuits.....	3-2
3-2	Interface Lines.....	3-3
3-3	Step Signal Timing.....	3-4
3-4	WGT Timing.....	3-5
3-5	Write Data Signal Timing.....	3-6
3-6	Index Signal Timing.....	3-6
3-7	Read Data Signal Timing.....	3-8
3-8	Disk Change Signal Timing.....	3-9
3-9	Read Data and Window Signal Timing.....	3-10
3-10	Step and Track 00 Timing.....	3-10
3-11	Access Timing.....	3-11
3-12	Write Timing.....	3-11
3-13	Read Timing.....	3-12
4-1	Removing the Collet Assembly.....	4-3
4-2	Replacing the Collet Assembly.....	4-4
4-3	Head Unload Spring in Relation to Spring Plate.....	4-5
4-4	Position of the Spring Plate.....	4-5
4-5	Carriage Assembly Position on the Base Frame	4-7
4-6	Removing the Head Load Cam.....	4-8
4-7	Installing the Head Load Cam Assembly.....	4-9
4-8	Write Protect or Media-In Sensor Connections.....	4-10
4-9	Installing the Write Protect or Media-In Sensor.....	4-10
4-10	Removing the Replacing the Optical Tachometer Sensor.....	4-11

## ILLUSTRATIONS (cont'd)

<u>Figure</u>	<u>Title</u>	<u>Page</u>
4-11	Removing the Sensor Cable Assembly.....	4-12
4-12	Installing the Index Sensor.....	4-13
4-13	Removing a Carbon Brush.....	4-14
4-14	Removing the Armature.....	4-15
4-15	Removing the Spindle Assembly.....	4-16
4-16	Removing the Front Panel.....	4-17
4-17	Adjusting the Picker Rod.....	4-18
4-18	Removing the Pop-Up Assembly and Guide Rail.	4-19
4-19	Removing the Door Lock Solenoid.....	4-20
4-20	Adjusting the Door Lock Solenoid.....	4-21
5-1	Location of Diagnostic Test Pins and Test Points.....	5-1
5-2	Head Radial Alignment Waveform.....	5-5
5-3	Adjusting Head Radial Alignment.....	5-6
5-4	Azimuth Waveform.....	5-7
5-5	Index Alignment Waveform.....	5-8
5-6	Waveforms at TP7 and TP10.....	5-9
5-7	Track 00 Signal.....	5-9
5-8	Head Load Waveform.....	5-11
6-1	FD1165 Flexible Disk Drive.....	6-5
6-2	G9NYF PCB Assembly.....	6-7

## TABLES

<u>Table</u>	<u>Title</u>	<u>Page</u>
1-1	FD1165 Specifications.....	1-5
2-1	Power Supply Specifications.....	2-6
2-2	Power Connector Part Number.....	2-6
2-3	Data and Control Interface Contact Assignments.....	2-9
2-4	Door Lock Jumper Combinations.....	2-14
4-1	Maintenance Tools.....	4-1
4-2	Maintenance Parts.....	4-2
5-1	Test Points and Signals.....	5-3
5-2	Adjustments.....	5-3
5-3	Head Radial Alignment Oscilloscope Settings.	5-4
5-4	Head Azimuth Oscilloscope Settings.....	5-6
5-5	Index Alignment Oscilloscope Settings.....	5-7
6-1	List of Illustrations.....	6-3

## LIST OF ABBREVIATIONS

A	Ampere
DIR	Direction Select
DCG	Disk Change
DLH	Door Lock Hold
DSX	Drive Select
FDD	Flexible Disk Drive
FM	Frequency Modulation
FUR	File Unsafe Reset
FUS	File Unsafe
HLD	Head Load
IC	Integrated Circuit
IDX	Index
I/O	Input/Output
k	1000
kg	Kilogram
LED	Light Emitting Diode
LSI	Large-Scale Integration
LWC	Low Write Current
mA	Milliampere
MB	Megabyte
MFM	Modified Frequency Modulation
ms	Millisecond
mV	Millivolt
PCB	Printed Circuit Board
POH	Power-On-Hours
pp	Peak-To-Peak
PRT	Write Protect
RDT	Read Data
RDY	Ready
rpm	revolutions per minute
SRD	Standardized Read Data
SSL	Side Select
STP	Step
SYC	Synchronization
TK0	Track 00
TSD	Two-Sided Disk
TTL	Transistor Transistor Logic
USE	In Use
Vdc	Volts direct current
VFO	Variable Frequency Oscillator
WDT	Write Data
WGT	Write Gate
WID	Window
μs	Microsecond



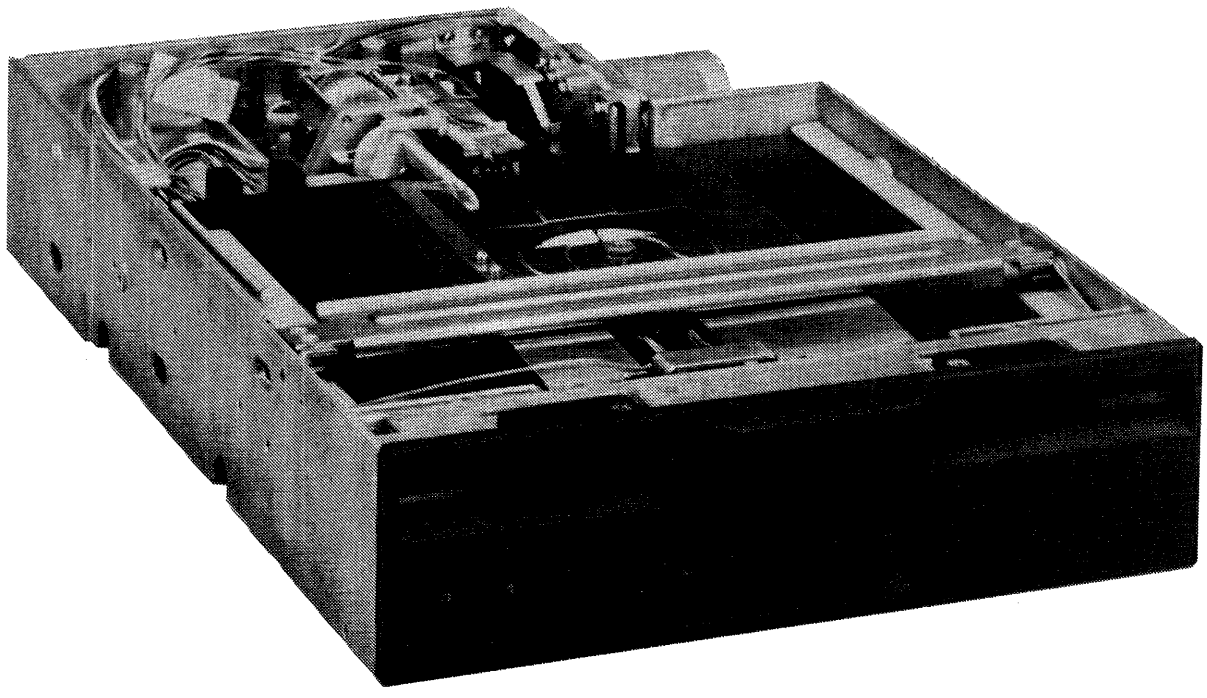

# CHAPTER 1

## GENERAL INFORMATION

This chapter gives an overall description of the Model FD1165 8-Inch Flexible Disk Drive, describes the features and parts of the disk drive in detail, and lists the specifications.

### 1.1 DESCRIPTION

The Model FD1165 Flexible Disk Drive is a compact magnetic disk storage device that uses single- or dual-sided, single- or double-density flexible disks. The storage capacity of the disk drive depends on the type and format of the diskette that is used. With a dual-sided flexible disk and a double-density format, the maximum-storage capacity is 1.6 million bytes (MB).

The most apparent features of the Model FD1165 are its small size and light weight. The disk drive measures 8.55 inches (217.2 mm) high, by 2.28 inches (58.0 mm) wide by 13.20 inches (335.0 mm) deep and weighs only 7.7 pounds (3.5 kg). The disk drive has all the features and performance of larger, conventional units, and is media-compatible and interface-compatible with them. Because the Model FD1165 measures one-half the height of conventional disk drives, two disk drives can be mounted in the same space as one conventional drive.

The Model FD1165 is operated by an external controller (NEC  $\mu$ PD765 is recommended) through a Transistor Transistor Logic (TTL) interface. The disk drive requires an external power supply that must supply and control two voltages, +5 Vdc (for the TTL) and +24 Vdc (for the dc direct drive spindle motor) (see Section 1.2.3). The disk drive features a microprocessor-controlled head loading mechanism that minimizes head and media wear. The head position mechanism (stepping motor) is also microprocessor-controlled to ensure extremely accurate head positioning.

## 1.2 CONSTRUCTION AND FEATURES

This section describes the construction of the Model FD1165 and explains the features of the various assemblies. See Figure 1-1 to identify the assemblies that are described in this section.

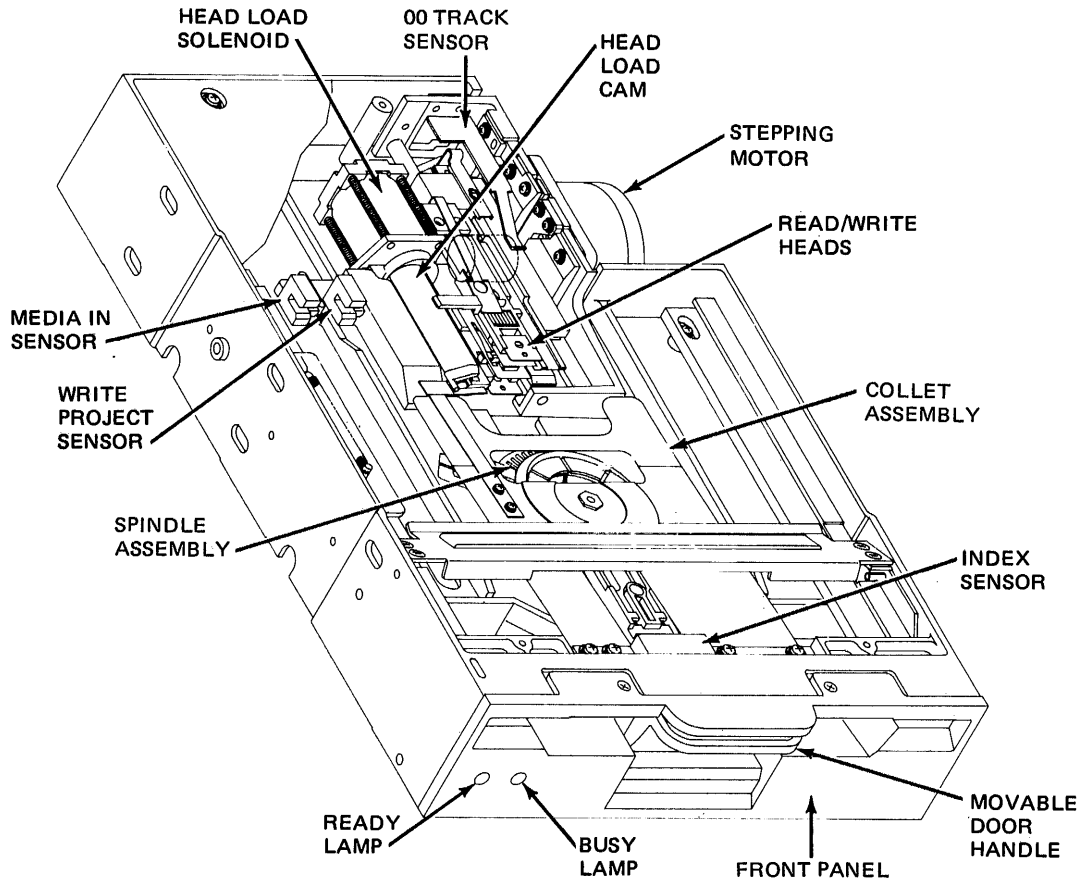

Figure 1-1 FD1165 Flexible Disk Drive

### 1.2.1 Base Frame

The base frame is the metal form that supports the sub-assemblies of the disk drive.

### 1.2.2 Spindle Assembly

The spindle assembly supports the flexible disk in the disk drive and rotates the flexible disk at 360 revolutions per minute (rpm).



### 1.2.3 Dc Direct Drive Spindle Motor

The dc direct drive motor (not shown) rotates the spindle assembly. This dc motor eliminates the problems that are associated with conventional ac motor drives.

- The motor does not use drive pulleys or belts, eliminating the problems associated with these parts.
- The motor consumes less power than conventional ac motors. Low-power, inexpensive power supplies can be used.
- The motor uses direct current, so that there are no concerns about voltages and frequencies.
- The motor generates less heat than conventional units.

The spindle motor has an up-to-speed time of 700 ms.

### 1.2.4 Carriage Read/Write Assembly Heads

The read/write heads touch each side of the flexible disk, allowing data to be written to the flexible disk and to be read from it. The read/write heads are part of a precision carriage assembly that shifts the heads from track to track. During the loading of a flexible disk, the read/write heads are held away from the surface of the flexible disk.

### 1.2.5 Stepping Motor

The stepping motor, under microprocessor control, positions the carriage assembly with a tensioned steel belt. This arrangement provides fast and accurate data access. For each pulse the stepping motor receives, the stepping motor shaft rotates 1.8 degrees. This action, in turn, moves the carriage 1/2 track on the flexible disk.

### 1.2.6 Head Load Cam Assembly

The head load cam assembly (rotary solenoid) lowers the heads onto the flexible disk with a force that is controlled by a microprocessor. This action prevents damage to the flexible disk and reduces wear of the read/write heads.

### 1.2.7 Pop-Up Feature

For easy removal of the flexible disk from the disk drive, the pop-up feature ejects the flexible disk from the disk drive when the door is opened. After ejection, the edge of the flexible disk protrudes approximately 1/2 inch (13 mm) from the disk drive.

### 1.2.8 Index Sensor

The index sensor is a combination LED and phototransistor that senses the index position of the flexible disk. The Model FD1165 has a dual index sensor to detect both single-sided and dual-sided flexible disks.

### 1.2.9 00 Track Sensor

The 00 Track sensor detects when the read/write head is at the 00 track (track 0, side 0).

### 1.2.10 Write Protect Sensor

The write protect sensor detects the presence or absence of a write protect notch on the flexible disk. If there is a notch, the write function is disabled. If no notch exists, the write function operation is enabled.

### 1.2.11 Media-In Sensor

The media-in sensor detects the presence of a flexible disk in the disk drive.

### 1.2.12 Collet Assembly

The collet assembly holds the flexible disk in position on the spindle when the door is closed.

### 1.2.13 Printed Circuit Board (PCB)

The PCB (not shown) supports the electronic drive and logic circuits of the disk drive.

### 1.2.14 Variable Frequency Oscillator (Optional)

The optional Variable Frequency Oscillator (VFO) PCB makes the interface signals to the controller more stable, increasing the overall reliability of the disk drive.

### 1.2.15 Display Lamps

Two lamps on the front panel provide a visual display of the ready and busy states of the disk drive.

### 1.2.16 Front Panel

The front panel holds the display lamps and provides an attractive appearance for the front of the disk drive.

### 1.2.17 Movable Door Handle

The movable door handle, when closed, engages the collet assembly.

### 1.2.18 Door Lock Solenoid

The door lock solenoid (not shown) makes it impossible to remove the flexible disk during certain drive operations, thereby preventing data loss or physical damage to the flexible disk.

## 1.3 SPECIFICATIONS

Table 1-1 lists the specifications for the Model FD1165 Flexible Disk Drive.

Table 1-1 FD1165 Specifications

FEATURES	SPECIFICATIONS								
	SINGLE-SIDED SINGLE-DENSITY			DUAL-SIDED SINGLE-DENSITY			DUAL-SIDED DUAL-DENSITY		
Unformatted Capacity (Kbytes)	400			800			1600		
Formatted Capacity									
Sectors/track	26	15	8	26	15	8	26	15	8
Bytes/sector	128	256	512	128	256	512	256	512	1024
Bytes/track	3328	3840	4096	3328	3840	4096	6656	7680	8192
K bytes/Disk	246	284	303	493	568	606	985	1137	1212
Media	IBM Diskette 1 or equivalent			IBM Diskette 2 or equivalent			IBM Diskette 2D or equivalent		
Media Dimensions (inches/mm)	8 x 8/203 x 203								
Tracks Per Disk	77			154			154		
Bit Density (bits per inch)	3268			3408			6816		
Transfer Rate (Kbytes per second)	31.25			31.25			62.5		
Recording Method	FM			FM			MFM		

Table 1-1 FD1165 Specifications (cont'd)

FEATURES	SPECIFICATIONS		
	SINGLE-SIDED SINGLE-DENSITY	DUAL-SIDED SINGLE-DENSITY	DUAL-SIDED DUAL-DENSITY
Track Density (tracks per inch)	48		
Rotational Speed (rpm)	360		
Access Times (ms)			
Track-to-track	3.0		
Seek settling time	15.5		
Head load time	30.0		
Latency time (average)	83.3		
Start time	700.0		
Power Requirements	+24 Vdc $\pm 10\%$ @ 0.9 Amp (maximum)		
	+5 Vdc $\pm 5\%$ @ 0.8 Amp (maximum) without VFO/ 0.9 Amp (maximum) with VFO		
Power Consumption	26 Watts (27 Watts with VFO)		
Physical dimensions			
Height	2.28 in. (58 mm)		
Width	8.55 in. (217.2 mm)		
Depth	13.19 in. (335 mm)		
Weight	7.7 pounds (3.5 Kg)		
Environment requirements			
Ambient temperature			
Operating	50°F to 113°F (10°C to 45°C)		
Nonoperating	23°F to 158°F (-5°C to 70°C)		
Relative humidity			
Operating	20% to 80%		
Reliability			
Mean Time Between Failures	24,000 Power On Hours (POH)		
Mean Time to Repair	0.5 hours		
Soft Error Rates	1 bit in 10 <sup>9</sup>		
Hard Error Rates	1 bit in 10 <sup>12</sup>		
Seek Error Rates	1 in 10 <sup>6</sup>		

## CHAPTER 2

### INSTALLATION AND OPERATION

This chapter gives unpacking and installation information and operating instructions for the Model FD1165 Flexible Disk Drive.

#### 2.1 PRELIMINARY INSPECTION

Before you unpack the Model FD1165, inspect the shipping carton for damage. If there is damage, notify the carrier immediately. Do not open the carton until the representative of the carrier inspects it. If the carton is undamaged, unpack the disk drive by following the unpacking instructions (see Section 2.2.1).

#### 2.2 UNPACKING AND REPACKING

This section describes unpacking and repacking the Model FD1165.

##### 2.2.1 Unpacking Procedure

To unpack the Model FD1165, refer to Figure 2-1 and use the following procedure. Save all shipping materials for possible use in reshipment.

- a. Remove the tape band from around the shipping package.
- b. Slide the styrofoam case out of the cardboard sleeve.
- c. Open the styrofoam case.
- d. Remove the plastic film cover from the disk drive.
- e. Inspect the disk drive for any shipment damage.

##### 2.2.2 Repacking Procedure

To repack the Model FD1165 for reshipment, reverse the procedure in Section 2.2.1.

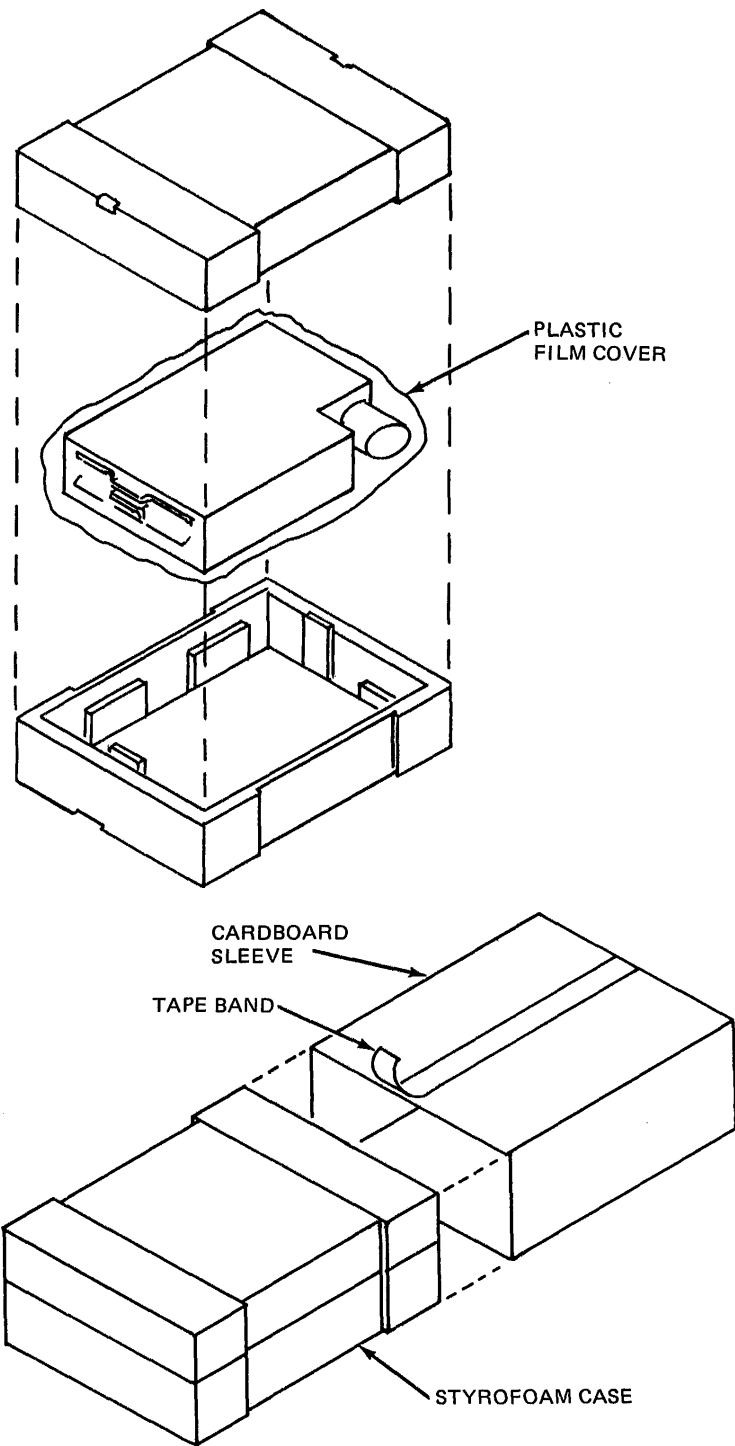

Figure 2-1 Unpacking

### 2.2.3 Preinstallation Inspection

After unpacking the Model FD1165, perform the following procedures.

- a. Inspect the disk drive for damage, loose parts, or other obvious indications of problems.
- b. Remove the dummy flexible disk from the unit.
- c. Insert a flexible disk through the door until the flexible disk locks in place and close the door.
- d. Press the door handle and make sure that the flexible disk is ejected.

## 2.3 ENVIRONMENTAL REQUIREMENTS

This section describes the required operating environment for the Model FD1165, gives space and weight data for the disk drive, and shows recommended mounting methods.

### 2.3.1 Operating Environment

The disk drive can be installed in any clean, relatively dust-free environment with an ambient temperature of 50°F to 113°F (10°C to 45°C) and relative humidity of 20% to 80%. The maximum stray magnetic field is 4000 Amperes per meter (A/m). Typical heat dissipation is 22.3 Kilogram Calories per Hour (Kcal/h) (23.3 Kcal/h with VFO).

### 2.3.2 Space and Weight Data

The unit should be mounted to provide space for cabling and servicing. Refer to Figure 2-2 for the physical dimensions of the disk drive. The unit weighs 7.7 pounds (3.5 kg).

### 2.3.3 Mounting

The disk drive can be mounted vertically, horizontally, or on-end. See Figures 2-3, 2-4, and 2-5 for recommended mounting methods. See Figure 2-6 for space requirements for adequate air flow. When the FD1165 is installed as recommended, no forced air cooling is necessary. If smooth air flow cannot be ensured, a forced air cooling system may be needed.

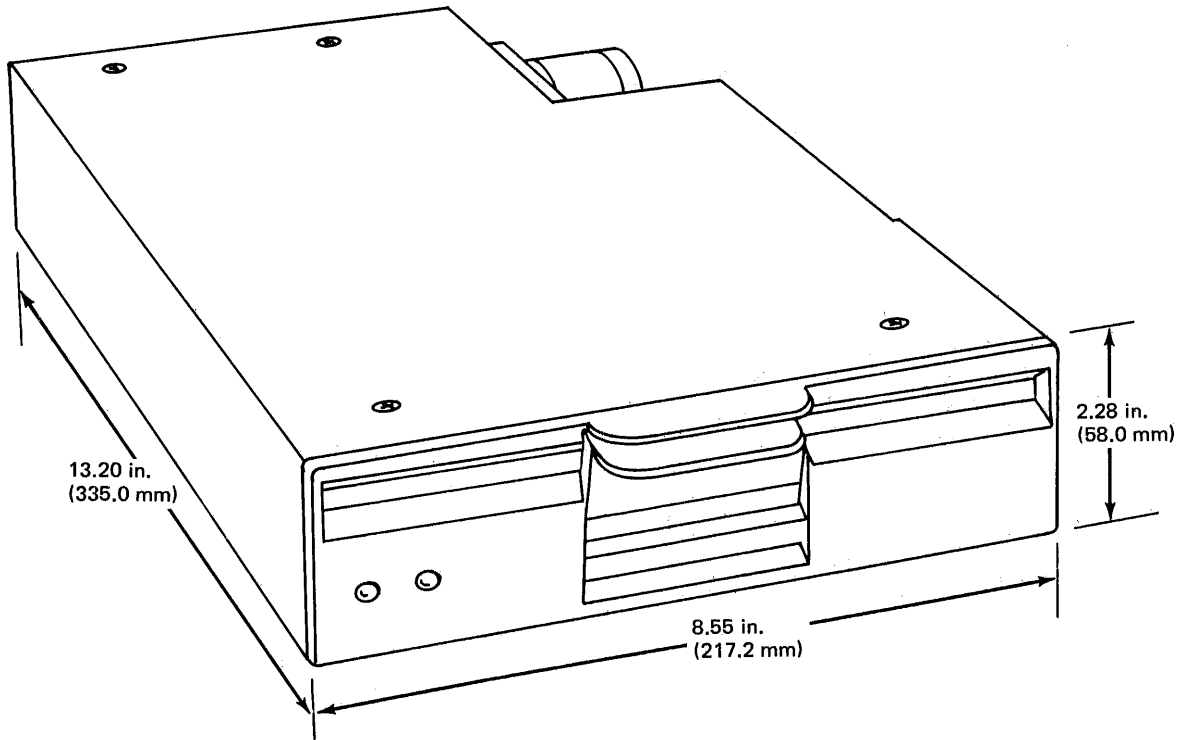

Figure 2-2 Model FD1165 Physical Dimensions

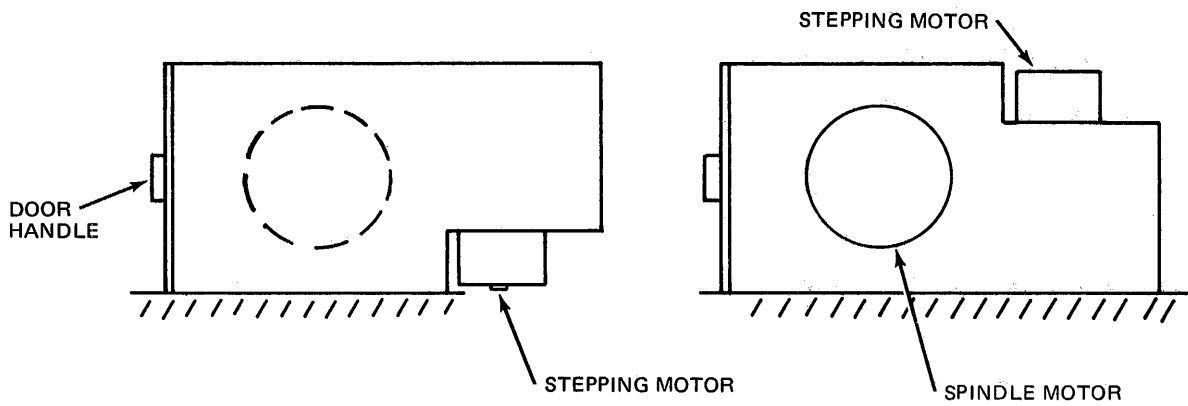

Figure 2-3 Vertical Installation

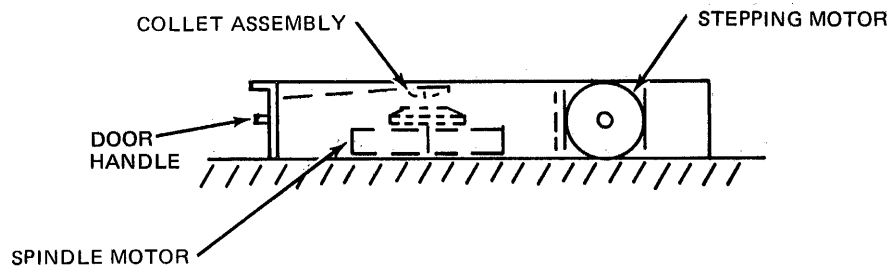

Figure 2-4 Horizontal Installation



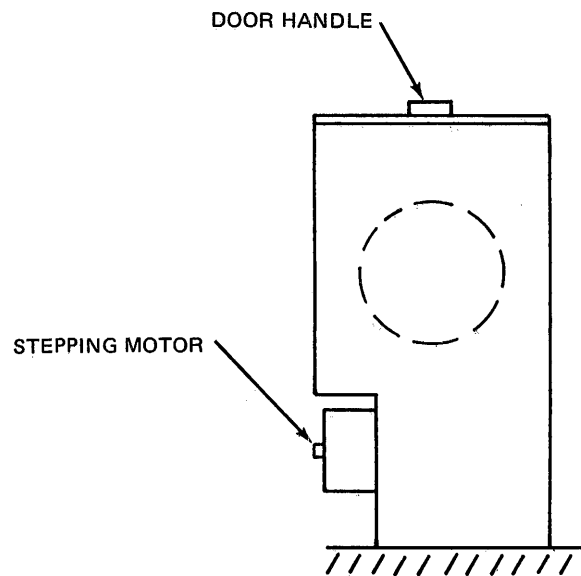
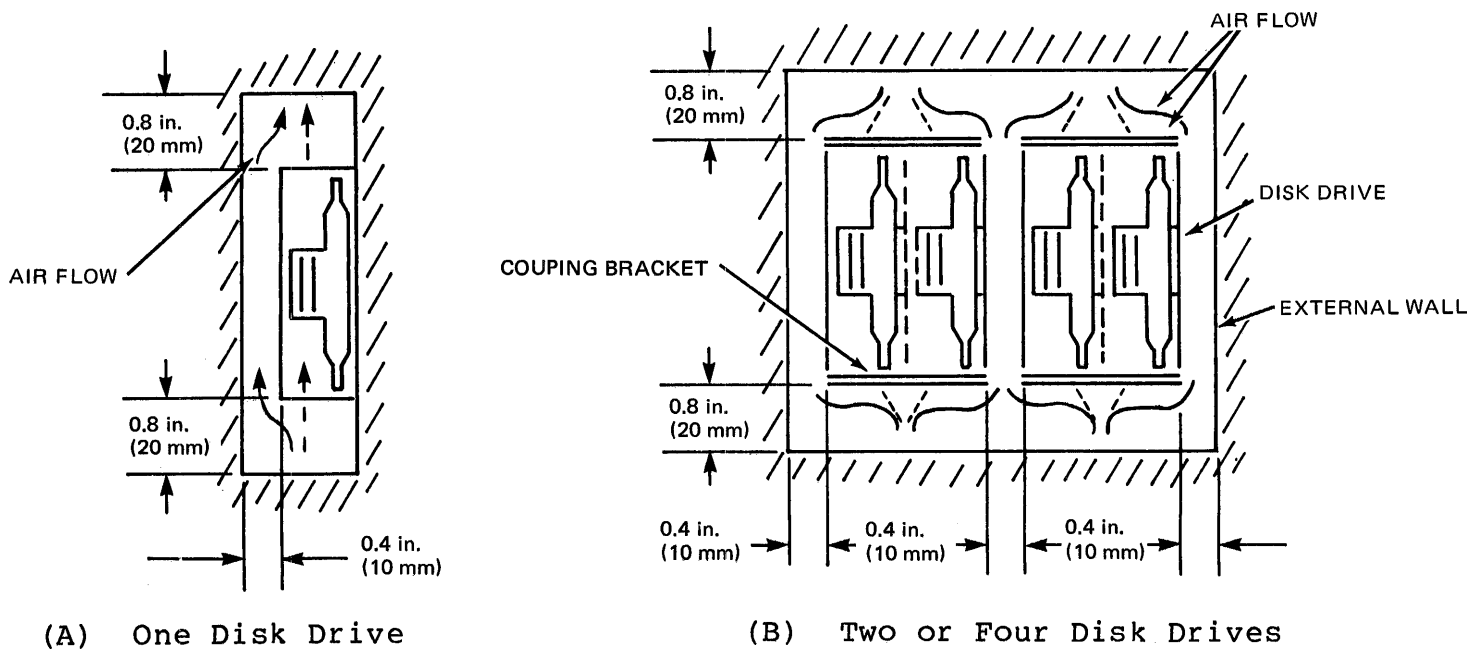

Figure 2-5 On-End Installation



NOTE: AIR FLOW SHOWN BY BROKEN LINES PASSES THROUGH DISK DRIVES THROUGH HOLES IN THE COUPLING BRACKET

Figure 2-6 Air Flow Requirements for Natural Air Cooling

## 2.4 POWER SUPPLY

This section describes power supply requirements for the Model FD1165.

### 2.4.1 Power Supply Specifications

Because the Model FD1165 does not include a power supply, a separate power supply must be provided. This power supply must provide +24 Vdc and +5 Vdc. See Table 2-1 for complete specifications.

Table 2-1 Power Supply Specifications

SPECIFICATION	+24 VDC SUPPLY	+5 VDC SUPPLY
Voltage	+24 $\pm$ 10%	+5 $\pm$ 5%
Normal Current (Operating)	0.75 A	0.8 A    0.9 A wo/VFO   w/VFO
Starting Current	0.9 A	0.8 A    0.9 A wo/VFO   w/VFO
Ripple Voltage*	Not greater than 400 mV pp	Not greater than 70 mV pp
Transient Response Time	200 ms	
* Not including voltage spikes.		

### 2.4.2 Power Connector

The power supply connects to the PCB of the Model FD1165 through a 7-pin connector. Table 2-2 lists the part numbers for the power connector. Figure 2-7 shows the power connector and its attachment to the disk drive.

Table 2-2 Power Connector Part Number

ITEM	AMP EI CONNECTOR	NEC PART NUMBER	QTY
Housing	171822-7	806-927339-0	1
Pin	170204-1	806-927340-0	5

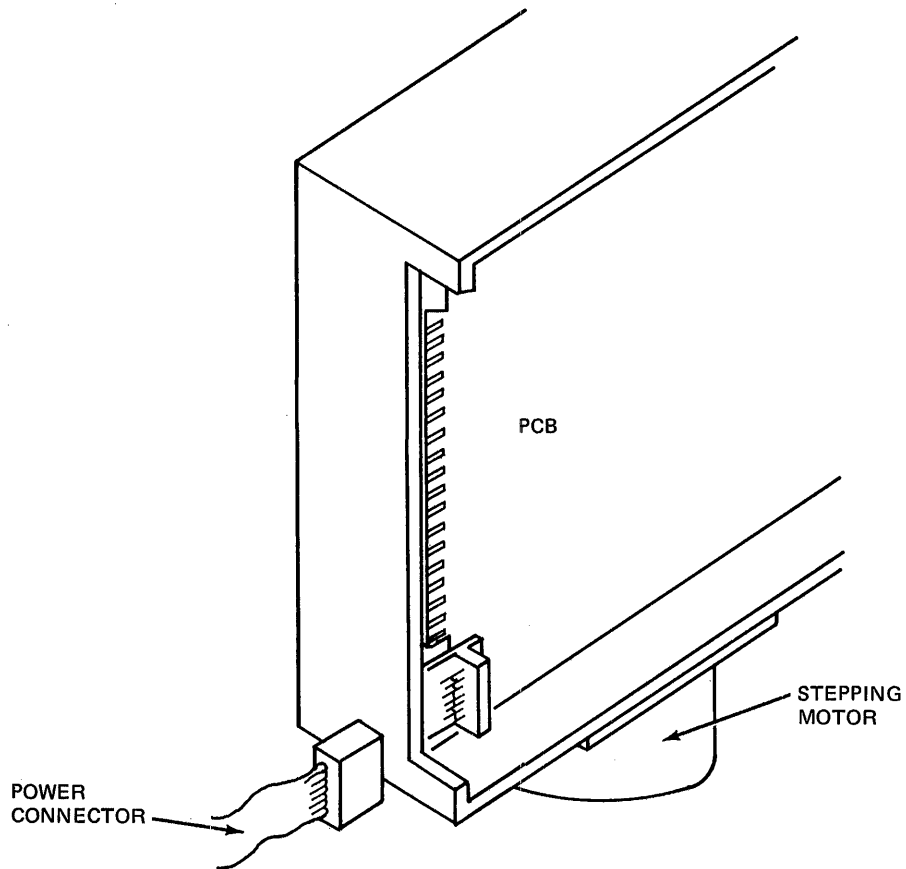

Figure 2-7 Power Connector Location

### 2.4.3 Power Connector Pin Assignments

The pin assignments for the power connector are shown in Figure 2-8.

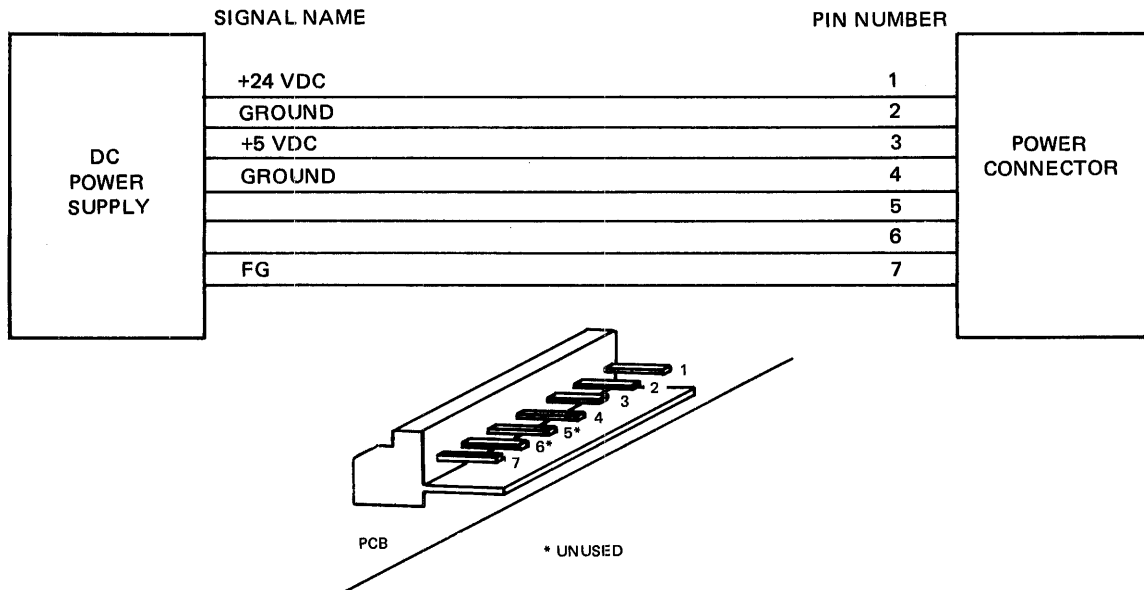

Figure 2-8 Pin and Line Assignments for the Power Connector

## 2.5 INTERFACE CONNECTION

The data and control line interface connector (3M Part Number 3415-0001) connects to a 50-contact edge connector that is located on the edge of the PCB. At the edge connector, the odd-numbered contacts, 1 through 49, are located on the noncomponent side of the PCB; the even numbered contacts, 2 through 50 are located on the component side of the PCB (see Figure 2-9). Figure 2-10 shows the recommended interface connector. Table 2-3 lists the contact assignments for the connector.

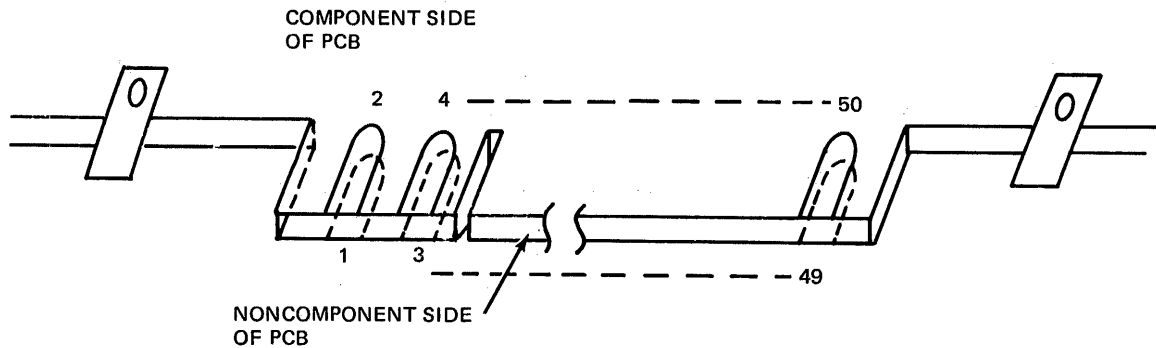

Figure 2-9 Contact Arrangement for Edge Connector

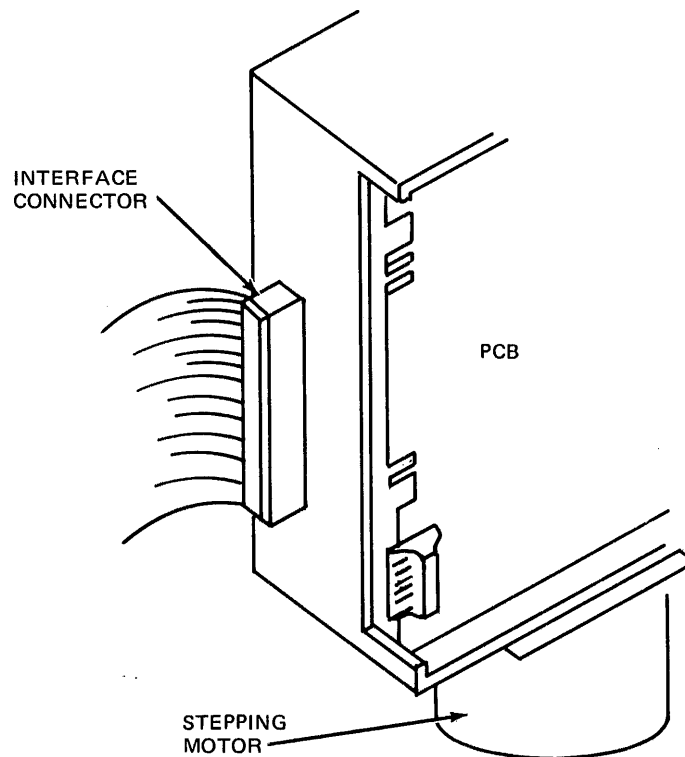

Figure 2-10 Interface Connector

Table 2-3 Data and Control Interface Contact Assignments

SIGNAL NAME	CONTACT NUMBER	SIGNAL NAME	CONTACT NUMBER
GROUND	1	LOW CURRENT	2
GROUND	3	UNSAFE RESET	4
GROUND	5	FILE UNSAFE*	6
GROUND	7	(UNUSED)	8
GROUND	9	TWO-SIDED	10
GROUND	11	DISK CHANGE	12
GROUND	13	SIDE SELECT*	14
GROUND	15	IN USE	16
GROUND	17	HEAD LOAD	18
GROUND	19	INDEX	20
GROUND	21	READY*	22
GROUND	23	VFO SYNC**	24
GROUND	25	DRIVE SELECT 1*	26
GROUND	27	DRIVE SELECT 2*	28
GROUND	29	DRIVE SELECT 3*	30
GROUND	31	DRIVE SELECT 4*	32
GROUND	33	DIRECTION SELECT	34
GROUND	35	STEP	36
GROUND	37	WRITE DATA	38
GROUND	39	WRITE GATE	40
GROUND	41	TRACK 00	42
GROUND	43	WRITE PROTECT	44
GROUND	45	READ DATA	46
GROUND	47	MFM**	48
GROUND	49	WINDOW**	50

\*Enabled by jumpers  
 \*\*Signals used only when VFO option is installed.

## 2.6 TERMINATOR RESISTORS

The Model FD1165 is shipped with terminator resistor arrays RN1 and RN2 installed as shown in Figure 2-11. Do not remove these resistors when only a single disk drive is used in a system. Do not remove these resistors when two or more disk drives are connected in parallel to a single controller (see Figure 2-12A). However, when two or more disk drives are connected in series to a single controller, remove RN1 and RN2 from each disk drive except the last one in the circuit (see Figure 2-12B).

TERMINATOR RESISTORS

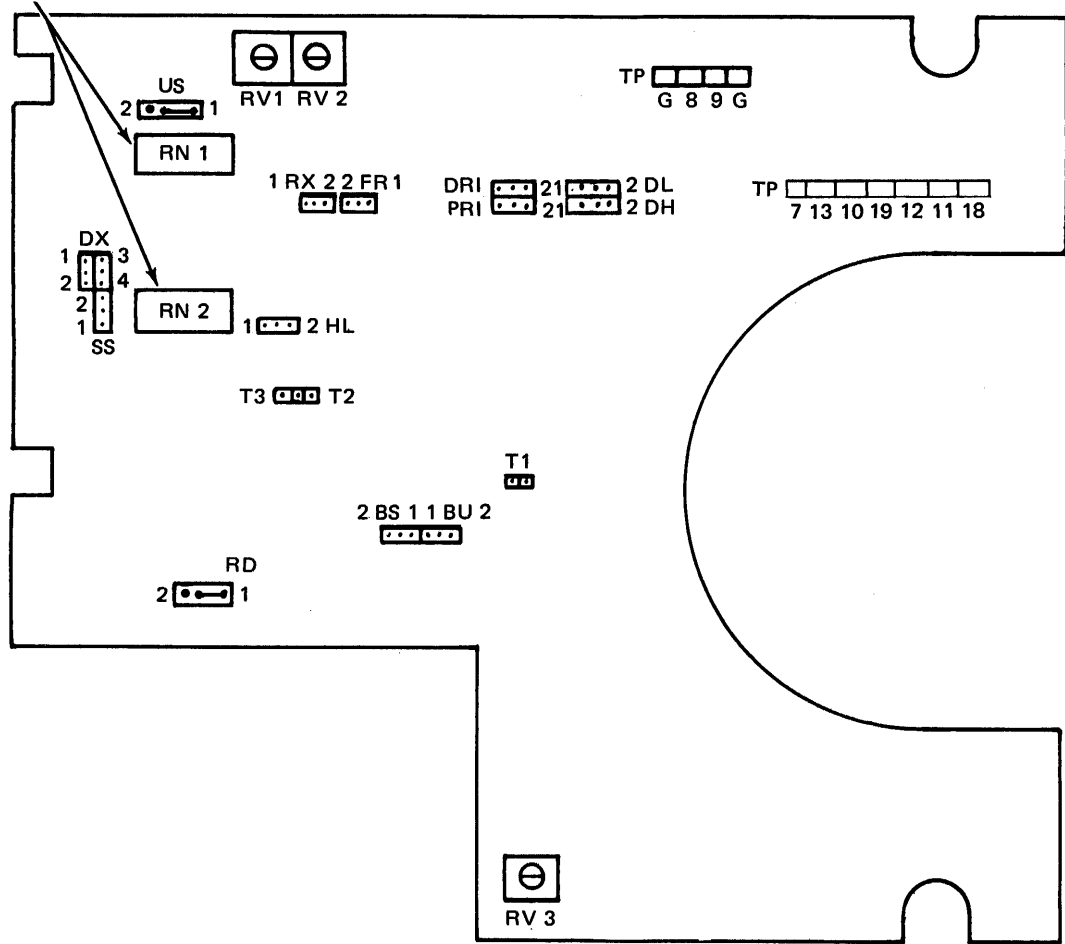

	DX1	DX2	DX3	DX4																																								
DX PLUG	<table border="1"> <tr><td>1</td><td>3</td></tr> <tr><td>•</td><td>•</td></tr> <tr><td>•</td><td>•</td></tr> <tr><td>•</td><td>•</td></tr> <tr><td>2</td><td>4</td></tr> </table>	1	3	•	•	•	•	•	•	2	4	<table border="1"> <tr><td>1</td><td>3</td></tr> <tr><td>•</td><td>•</td></tr> <tr><td>•</td><td>•</td></tr> <tr><td>•</td><td>•</td></tr> <tr><td>2</td><td>4</td></tr> </table>	1	3	•	•	•	•	•	•	2	4	<table border="1"> <tr><td>1</td><td>3</td></tr> <tr><td>•</td><td>•</td></tr> <tr><td>•</td><td>•</td></tr> <tr><td>•</td><td>•</td></tr> <tr><td>2</td><td>4</td></tr> </table>	1	3	•	•	•	•	•	•	2	4	<table border="1"> <tr><td>1</td><td>3</td></tr> <tr><td>•</td><td>•</td></tr> <tr><td>•</td><td>•</td></tr> <tr><td>•</td><td>•</td></tr> <tr><td>2</td><td>4</td></tr> </table>	1	3	•	•	•	•	•	•	2	4
1	3																																											
•	•																																											
•	•																																											
•	•																																											
2	4																																											
1	3																																											
•	•																																											
•	•																																											
•	•																																											
2	4																																											
1	3																																											
•	•																																											
•	•																																											
•	•																																											
2	4																																											
1	3																																											
•	•																																											
•	•																																											
•	•																																											
2	4																																											

	POS1	POS2																
RX,HL,DR, PR, DL, DH, BU, JUMPERS	<table border="1"> <tr><td>1</td><td>•</td><td>•</td><td>2</td></tr> <tr><td>•</td><td>•</td><td>•</td><td>•</td></tr> </table>	1	•	•	2	•	•	•	•	<table border="1"> <tr><td>1</td><td>•</td><td>•</td><td>2</td></tr> <tr><td>•</td><td>•</td><td>•</td><td>•</td></tr> </table>	1	•	•	2	•	•	•	•
1	•	•	2															
•	•	•	•															
1	•	•	2															
•	•	•	•															

	POS1	POS2																
BS,FR, JUMPERS	<table border="1"> <tr><td>2</td><td>•</td><td>•</td><td>1</td></tr> <tr><td>•</td><td>•</td><td>•</td><td>•</td></tr> </table>	2	•	•	1	•	•	•	•	<table border="1"> <tr><td>2</td><td>•</td><td>•</td><td>1</td></tr> <tr><td>•</td><td>•</td><td>•</td><td>•</td></tr> </table>	2	•	•	1	•	•	•	•
2	•	•	1															
•	•	•	•															
2	•	•	1															
•	•	•	•															

	POS1	POS2																
US,RD PINS (SOLDER TYPE)	<table border="1"> <tr><td>2</td><td>•</td><td>•</td><td>1</td></tr> <tr><td>•</td><td>•</td><td>•</td><td>•</td></tr> </table>	2	•	•	1	•	•	•	•	<table border="1"> <tr><td>2</td><td>•</td><td>•</td><td>1</td></tr> <tr><td>•</td><td>•</td><td>•</td><td>•</td></tr> </table>	2	•	•	1	•	•	•	•
2	•	•	1															
•	•	•	•															
2	•	•	1															
•	•	•	•															

Figure 2-11 Terminator Resistors and Jumper Locations on the PCB

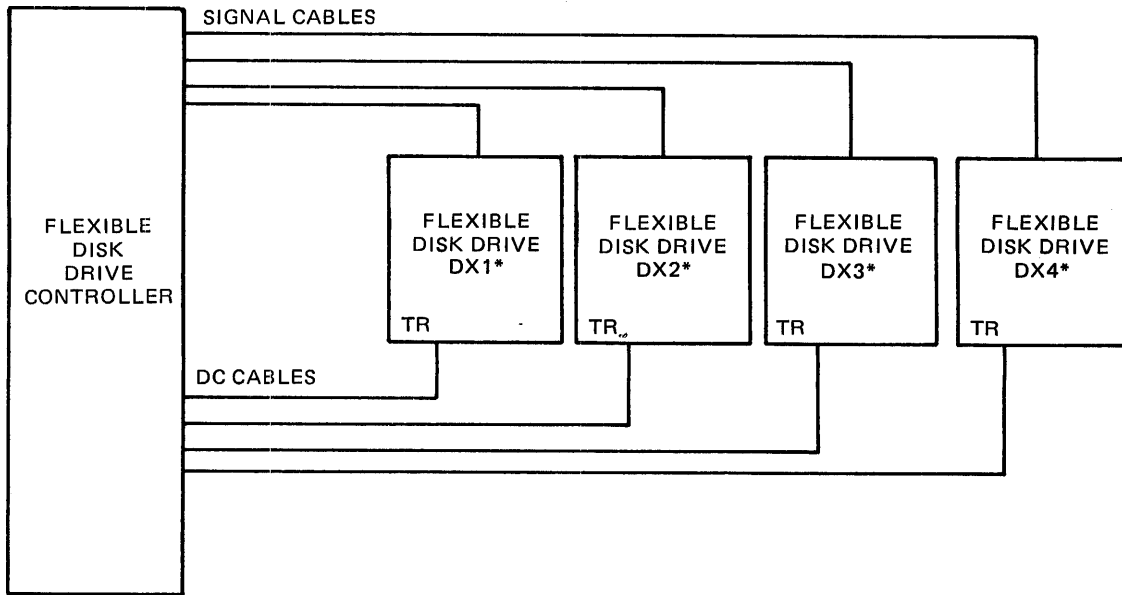

(A) PARALLEL CONFIGURATION

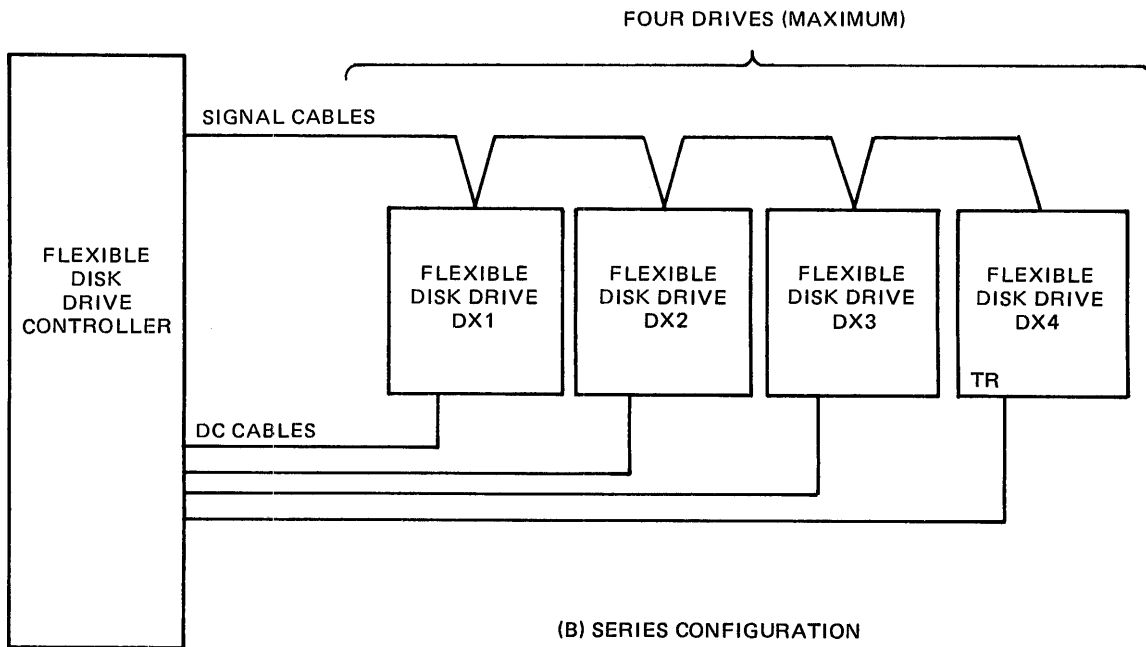

(B) SERIES CONFIGURATION

TR = TERMINATOR RESISTOR

Figure 2-12 Parallel and Series Configurations

## 2.7 DRIVE IDENTIFICATION (DX) SELECTION

The controller identifies each disk drive in a system by the position of the drive identification (DX) jumper on the disk drive. When only one disk drive is used in a system, insert the DX jumper (see Figure 2-11) to identify that disk drive as DX1. When two to four disk drives are used in a system, assign each one a different DX number and insert the jumper for that unit accordingly (see Figure 2-11). A maximum of four disk drives can be used in a system. The Model FD1165 is supplied with the DX jumper in the DX1 position.

## 2.8 OPTION SELECTION

The Model FD1165 can be tailored to fulfill specific system requirements by changing the positions of the option selection jumpers on the PCB. This section describes the options that are available by using the jumpers. See Figure 2-11 for the location of the jumpers. For an explanation of the signals that are affected by changing the option selection jumpers, see Chapter 3.

### 2.8.1 Head Load Jumper (HL)

A Head Load signal from the controller initiates head load action when the HL jumper is in the HL1 position. When the jumper is in the HL2 position, a Drive Select signal from the controller initiates head load action. The FD1165 is supplied with HL1 selected.

### 2.8.2 Radial Ready Jumper (RX)

In the RX1 position, the Ready signal from the disk drive is gated by the Drive Select signal. In the RX2 position, the Ready signal is independent of the Drive Select signal. The FD1165 is supplied with the RX1 selected.

### 2.8.3 Side Select Jumper (SS)

The Side Select signal from the controller determines the disk side when the SS jumper is in the SS1 position. When the jumper is in the SS2 position, the Direction Signal from the controller determines the disk side. If the Direction Signal level is High, side 0 is selected. If the Direction Signal level is Low, side 1 is selected. The FD1165 is supplied with SS1 selected.



#### 2.8.4 Write Protect Jumper (PR)

If the flexible disk has a write protect notch and jumper position PR1 is selected, the disk drive sends a write protect signal to the controller and inhibits recording on the disk. If jumper position PR2 is selected, the disk drive sends the write protect signal to the controller but recording on the disk is permitted. The disk drive is supplied with PR1 selected.

#### 2.8.5 File Unsafe Jumper (FR)

Jumper position FR1 disables the File Unsafe function. Jumper position FR2 enables the File Unsafe function. The disk drive is supplied with FR2 selected.

#### 2.8.6 Door Lock Jumpers (DL, DR, DH)

The Model FD1165 has three door lock jumpers which are used in different combinations with the In Use signal to determine the door lock condition. This section describes the functions of the door lock jumpers.

##### 2.8.6.1 DR Jumper

When DR1 is selected, the Ready signal from the controller enables the door lock function (see Table 2-4). When DR2 is selected, the door locks function is independent of the Ready signal. The disk drive is supplied with DR1 selected.

##### 2.8.6.2 DL Jumper

In the DL1 position, In Use and Drive Select signals lock the door. In the DL2 position, the In Use signal locks the door (see Table 2-4). The disk drive is supplied with DL1 selected.

##### 2.8.6.3 DH Jumper

When DH1 is selected, a Door Lock Hold signal (generated by the disk drive) locks the door. In the DH2 position, the Door Lock Hold signal is disabled (see Table 2-4). The disk drive is supplied with DH1 selected.

Table 2-4 Door Lock Jumper Combinations

JUMPER POSITION			DOOR LOCK LOGIC (SIGNALS NEEDED FOR DOOR LOCK TO OCCUR)
DR	DL	DH	
1	1	1	RDY . (HLD . DSX) + (USE AND DSX)
1	1	1	RDY . (HLD . DSX) + (USE AND DSX) + DLH
1	2	2	RDY . (HLD . DSX) + USE + DLH
1	2	1	RDY . (HLD . DSX) + USE
2	2	1	HLD . DSX + USE
2	2	2	HLD . DSX + USE + DLH
RDY = Ready HLD = Head Load DSX = Drive Select USE = In Use DLH = Door Lock Hold			. = And + = Or

#### 2.8.7 In Use Pins (US)

The In Use pins are solder-type pins; they cannot be selected by jumper. To enable the In Use signal, solder Pin 1 to the center pin. To disable the In Use signal, solder Pin 2 to the center pin. The disk drive is supplied with US1 connected to the center pin.

#### 2.8.8 Read Data Pins (RD)

The read data pins are solder-type connectors. To enable the Read Data signal, solder Pin 1 to the center pin. To enable the Standardized Read Data signal (for the VFO option), solder Pin 2 to the center pin. The Model FD1165 is supplied with RD1 connected to the center pin.

#### 2.8.9 Busy Lamp Jumpers (BU, BS)

The busy lamp jumpers determine the conditions under which the busy lamp will be on. The unit is supplied with BU2 and BS2 selected.

##### 2.8.9.1 Busy Lamp On During Head Load

To have the busy lamp on when a Head Load signal is present, select BU2 and BS2.

### 2.8.9.2 Busy Lamp On During Drive Select

To have the busy lamp on when a drive select signal is present, select BU2 and BS1.

### 2.8.9.3 Busy Lamp On During In Use

To have the busy lamp on when an In Use signal is present, select BU1 and remove the BS jumper.

## 2.9 OPERATING THE FD1165

This section describes inserting a flexible disk into the disk drive and removing a flexible disk from the disk drive.

### 2.9.1 Inserting a Flexible Disk

Use this procedure to insert a flexible disk into the disk drive.

- a. Turn on the dc power supply.
- b. Insert a flexible disk into the FD1165 until the flexible disk locks in place and close the door (see Figure 2-13).

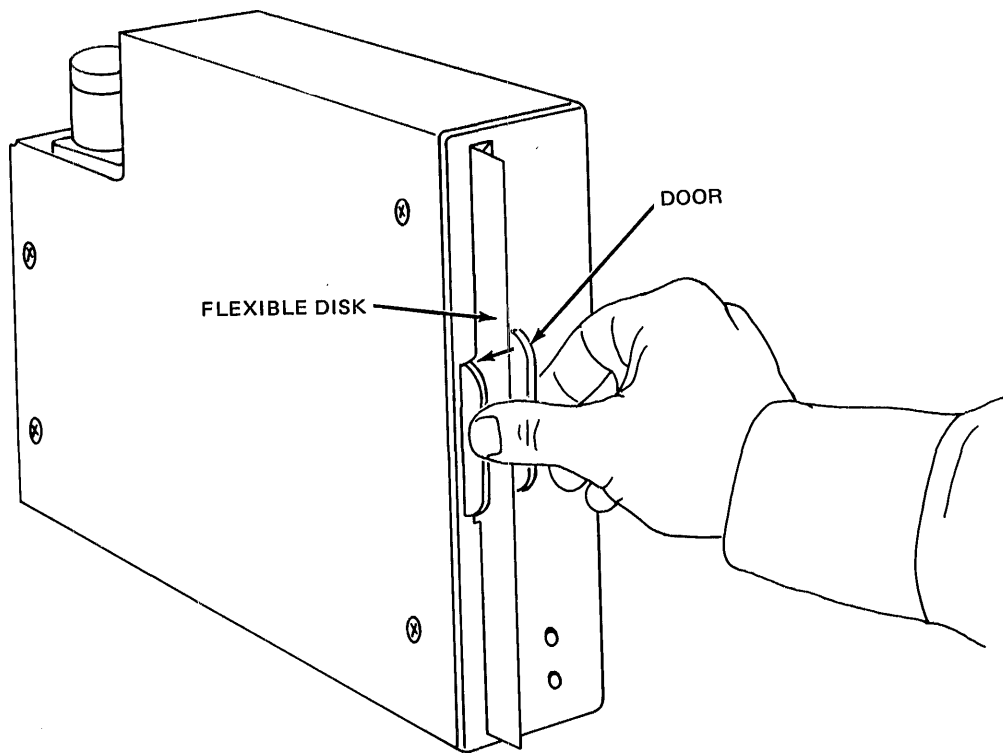

Figure 2-13 Closing the Door of the FD1165

### 2.9.2 Removing a Flexible Disk

Use this procedure to remove a flexible disk from the FD1165.

- a. Make sure that the busy lamp at the front of the FD1165 is off.
- b. Press the door handle as shown in Figure 2-14; the door unlocks and the flexible disk is ejected.

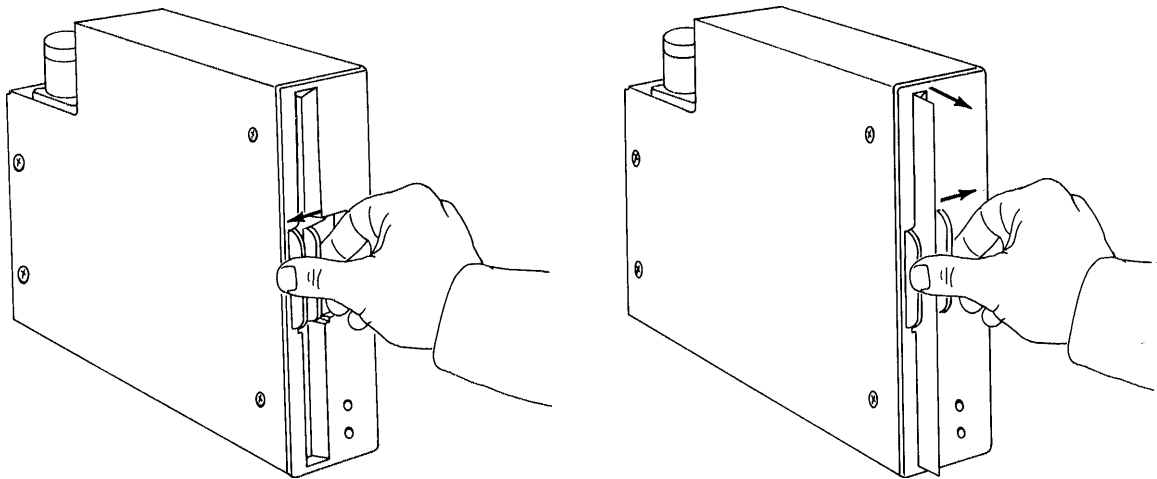

Figure 2-14 Unlocking the Door and Removing the Flexible Disk

## 2.10 DISPLAY LAMPS

The FD1165 has two display lamps on the front panel, the ready lamp and the busy lamp.

### 2.10.1 Ready Lamp

The ready lamp shows that the FD1165 is ready for use. The lamp is lit when the following conditions are met.

- Dc power is supplied.
- A flexible disk is loaded and the door is closed.
- The flexible disk is rotating at 70% (or better) of the prescribed speed (360 rpm) and the Index pulse is detected more than four times.

### 2.10.2 Busy Lamp

The busy lamp indicates that the disk drive is selected, in use, or that the read/write heads are loaded (depending on the position of the BU/BS jumpers; see Section 2.8.9).



## CHAPTER 3

### INTERFACE INFORMATION

This chapter gives interface information for the Model FD1165.

#### 3.1 BASIC OPERATIONAL DESCRIPTION

When a flexible disk is inserted into the Model FD1165 and the door handle is closed, the collet presses into the center hole of the flexible disk centering the disk and clamping it in operating position on the spindle. At the same time, this action switches the drive motor on. The drive motor moves the spindle that, in turn, rotates the flexible disk. Sensors in the disk drive detect the following conditions.

- The flexible disk is inserted properly and the door slot is closed.
- A single- or dual-sided flexible disk is loaded.
- The flexible disk has a write protect notch.
- The read/write head is located on the track 00 of the flexible disk.

An index sensor provides a time reference by generating a pulse for each rotation of the flexible disk. After the flexible disk reaches 70% of its prescribed speed and the Index pulse is detected four times, a Ready signal is sent to the controller. The FD1165 is "ready" about 700 ms after the door is closed.

After the disk drive receives a Step signal and a Direction Select signal (see Sections 3.3.3 and 3.3.4), it energizes the stepping motor to move the read/write heads to the proper track. One of the two read/write heads is selected by the Side Select signal. When the disk drive receives a Head Load signal, the heads are loaded onto the flexible disk by the head load cam. Once the head is loaded, the disk drive reads from or writes to the disk when it receives a Read Data or Write Data signal from the controller.

### 3.2 ELECTRICAL INTERFACE

This section gives a description of the signal levels, the driver/receiver circuits, and the interface lines of the FD1165.

#### 3.2.1 Signal Levels

The input and output signals are at TTL levels and have the following electrical specifications.

True = Logic 0 (low level), 0 to +0.4 Vdc

False = Logic 1 (high level), +2.5 to +5.25 Vdc

#### 3.2.2 Driver/Receiver Circuits

Each driver circuit delivers a signal, on an interface line, to the controller from the disk drive. All driver circuits are the open-collector type of SN7438 Integrated Circuit (IC). The SN7438 driver circuits sink a maximum current of 40 mA at the low level.

Each receiver circuit receives a drive signal from the controller. The receiver circuits are Large Scale Integration (LSI) gate circuits that terminate with 150-ohm resistors. Lines receiving at high speeds use a Schmitt trigger gate. Figure 3-1 shows the recommended driver/receiver circuits.

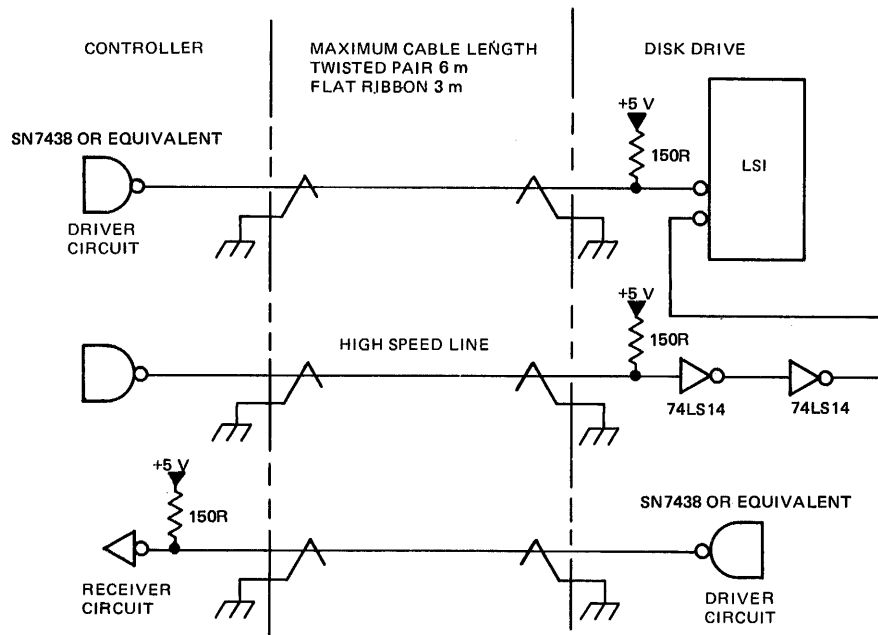
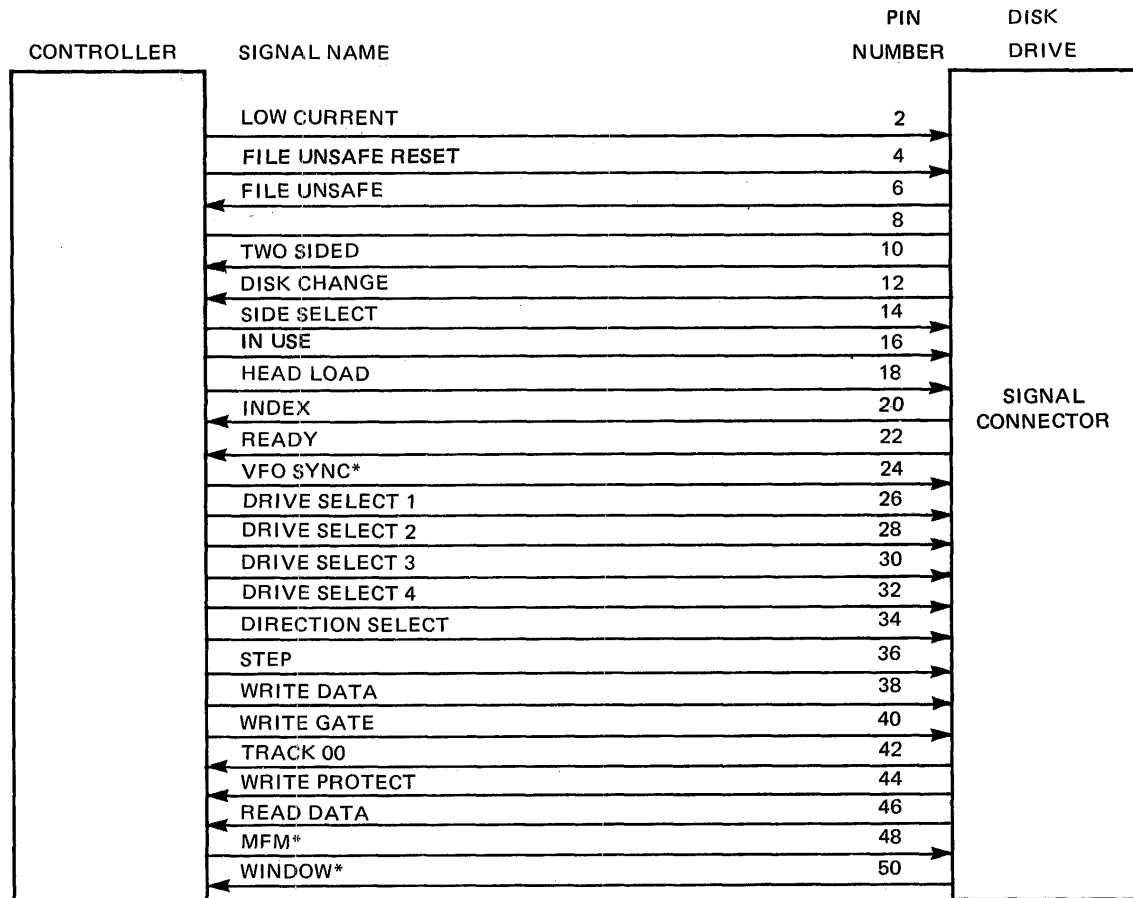

Figure 3-1 Driver/Receiver Circuits



### 3.2.3 Interface Lines

The interface lines for the FD1165 are shown in Figure 3-2. The even-numbered lines (2 through 50) are signal lines. The odd-numbered lines (1 through 49) are grounds. The lines are named for the input or output signals that they carry.



\* SIGNALS USED ONLY WHEN VFO OPTION IS INSTALLED

Figure 3-2 Interface Lines

### 3.3 INPUT SIGNALS

This section describes the input signals that are carried on the interface lines for the Model FD1165.

#### 3.3.1 Drive Select 1 Through 4 (DSX1 to 4)

These signals select one disk drive in the system for input/output (I/O). When one of the signals (DSX1 to DSX4) is Low, the corresponding disk drive is selected. See Section 2.7 for the identification selection procedure.

### 3.3.2 Head Load (HDL)

When the disk drive is in the ready state, a Low on this line initiates loading of the read/write heads.

### 3.3.3 Step (STP)

This pulse directs the stepping motor to move the read/write heads from track to track. The direction of movement is determined by the Direction Select signal (see Section 3.3.4). Figure 3-3 shows the repetition rate and width of the Step pulse. The heads start to move at the leading (positive-going) edge of each pulse. One pulse moves the heads 1/2 track.

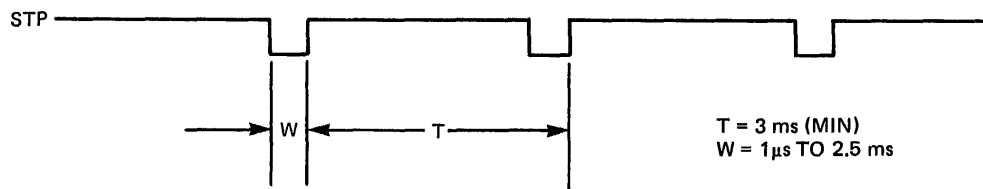

Figure 3-3 Step Signal Timing

### 3.3.4 Direction Select (DIR)

If the Direction Select signal is High, the head moves toward the external tracks. If DIR is Low, the head moves toward the internal tracks. The trailing edge of this signal occurs 1 μs before the leading edge of the STP signal.

### 3.3.5 Side Select (SSL)

This signal selects the side of the disk that is used for the read/write operation. If the Side Select signal is High, side 0 (upper side) is selected. If SSL is Low, side 1 (lower side) is selected. When a single-sided flexible disk is used, side 0 is selected. The SSL signal must occur at least 100 μs before the read/write operation begins.

### 3.3.6 Write Gate (WGT)

This signal selects the read or write operation. If the signal is Low, data is written to the disk. If the signal is High, data is read from the disk. During the Write operation, data is erased between adjacent tracks on the flexible disk for 560  $\mu\text{s}$  after WGT goes High. During this 560  $\mu\text{s}$ , the Head Load signal cannot be disabled, the Side Select signal cannot be changed, and the Step operation cannot be enabled. These signals can be changed only when the WGT and Erase signals are both High. Figure 3-4 is the WGT timing chart.

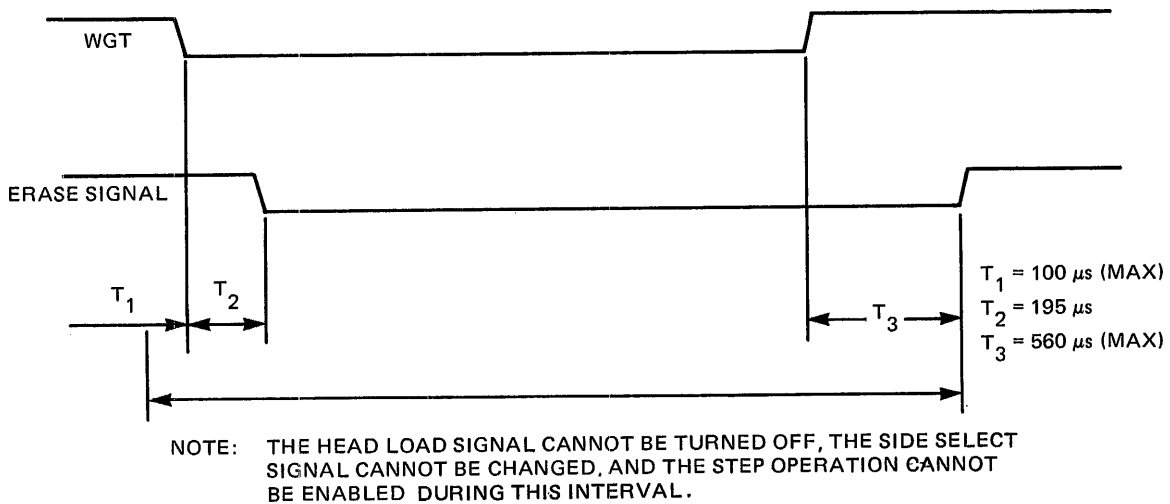

Figure 3-4 WGT Timing

### 3.3.7 Write Data (WDT)

The signals on this line contain the data that is written on the flexible disk. The data is in Frequency Modulated (FM) or in Modified Frequency Modulated (MFM) format (see Figure 3-5).

### 3.3.8 Low Write Current (LWC)

This signal controls the write current amplitude to compensate for the difference in density between the inner and outer tracks of the flexible disk. The LWC signal is High for external tracks (00 to 42) and Low for internal tracks (43 to 76).

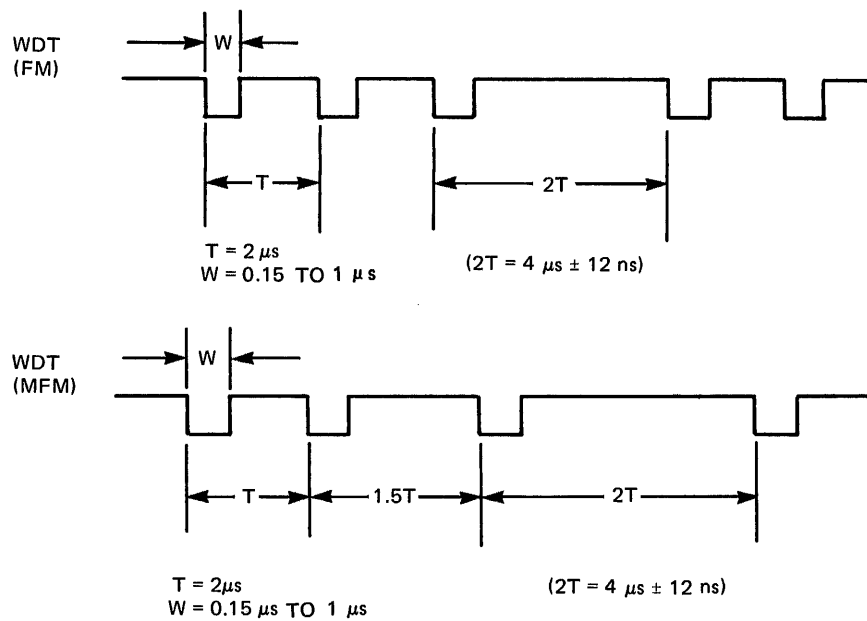

Figure 3-5 Write Data Signal Timing

### 3.3.9 File Unsafe Reset (FUR)

A low FUR signal resets the File Unsafe status (see Section 3.4.5).

### 3.3.10 In Use (USE)

The USE line goes Low to instruct the disk drive to lock the door (see Section 2.8.6 and 2.8.7).

## 3.4 OUTPUT SIGNALS

This section describes the output signals of the Model FD1165.

### 3.4.1 Index (IDX)

This signal occurs on the Index Line once for every rotation of the flexible disk. Figure 3-6 shows the IDX pulse.

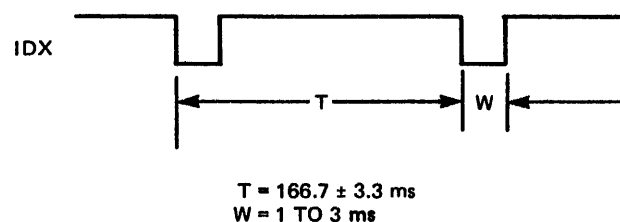

Figure 3-6 Index Signal Timing

#### 3.4.2 Track 00 (TK0)

When the read/write heads are on the zero (0) track on side 0 of the flexible disk, this signal goes Low.

#### 3.4.3 Dual-Sided (TSD)

The TSD signal goes High if the flexible disk is single-sided; the signal goes Low if the flexible disk is dual-sided. If there is no flexible disk inserted, TSD stays High.

#### 3.4.4 Ready (RDY)

The Ready signal goes Low when the Model FD1165 is ready for use. The signal indicates that the following conditions exist.

- Dc power is supplied.
- A flexible disk is inserted and the door is closed.
- The flexible disk has reached 70% of its prescribed rotational speed and four IDX pulses have been generated.
- The flexible disk is single-sided and side 0 is detected.

#### 3.4.5 File Unsafe (FUS)

The File Unsafe signal goes Low when an alarm condition occurs. The low FUS disables write operations and is reset to High by a File Unsafe Reset signal. The line goes Low for any of the following conditions.

- The Write Data signal does not appear within 18  $\mu$ s after the Write Gate signal becomes active.
- The Write Gate signal is active but the Head Load signal is not.
- The Write Gate signal is active but the Ready signal is not.
- The Step signal is active at the same time that the Write gate signal is active.

### 3.4.6 Read Data (RDT)

A signal on this line conditions the data that is sent from the disk drive to the host system. The line transmits the Read Data or the Standardized Read Data signal depending upon the position of the RD jumper (see Section 2.8.8). Figure 3-7 shows typical RDT-conditioned signals.

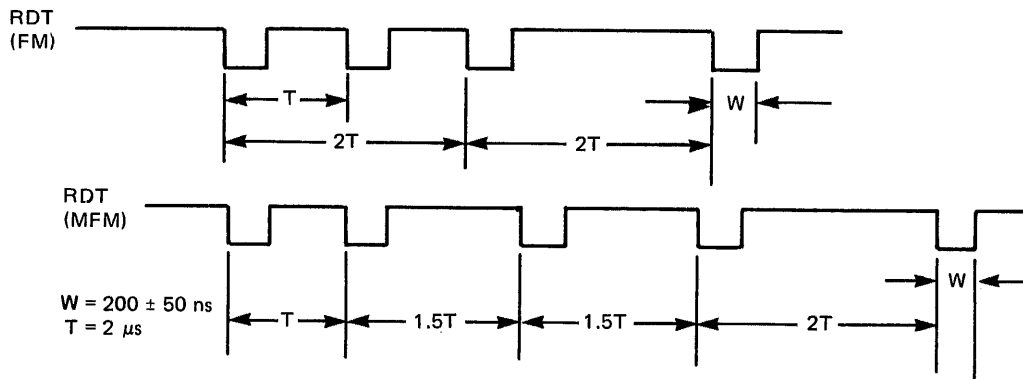

Figure 3-7 Read Data Signal Timing

### 3.4.7 Write Protect (PRT)

The Write Protect signal goes High when the flexible disk does not have a write protect notch. If the flexible disk has a write protect notch, the Write Protect signal goes Low. A Low Write Protect signal puts the flexible disk in a write-protected state.

### 3.4.8 Disk Change (DCG)

When the flexible disk has been changed since the disk drive was last selected, this signal goes Low. Figure 3-8 shows the Disk Change signal timing.

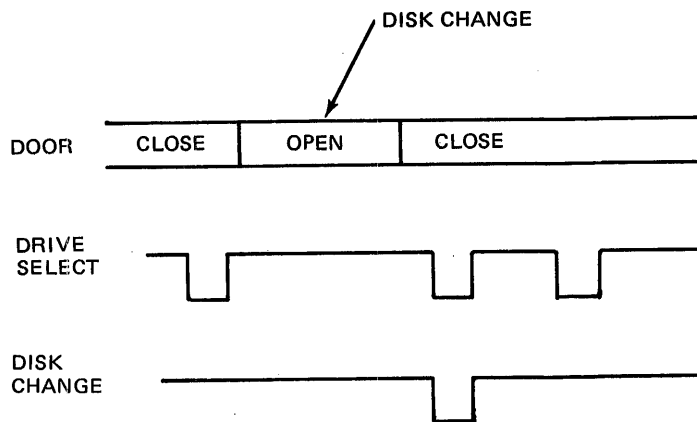

Figure 3-8 Disk Change Signal Timing

### 3.5 VFO INTERFACE SIGNALS

The optional VFO interface signals are described in the following sections.

#### 3.5.1 Modified Frequency Modulation Mode (MFM)

The MFM signal is Low when MFM data is read or written. The line is High when FM data is read or written.

#### 3.5.2 VFO Synchronization (SYC)

The SYC signal goes Low when read data is synchronized by the VFO circuit.

#### 3.5.3 Standardized Read Data (SRD)

The SRD line conveys Standardized Read Data. The data is synchronized by the VFO circuit to make it easily and more reliably read.

#### 3.5.4 Window (WID)

The controller uses the WID signal to distinguish between clock pulses and data output by phase-matching the Window signal with the Standardized Read Data signal. Figure 3-9 shows the timing relationship between the signals. Once the data splice point is passed, timing becomes irregular until the VFO is resynchronized.

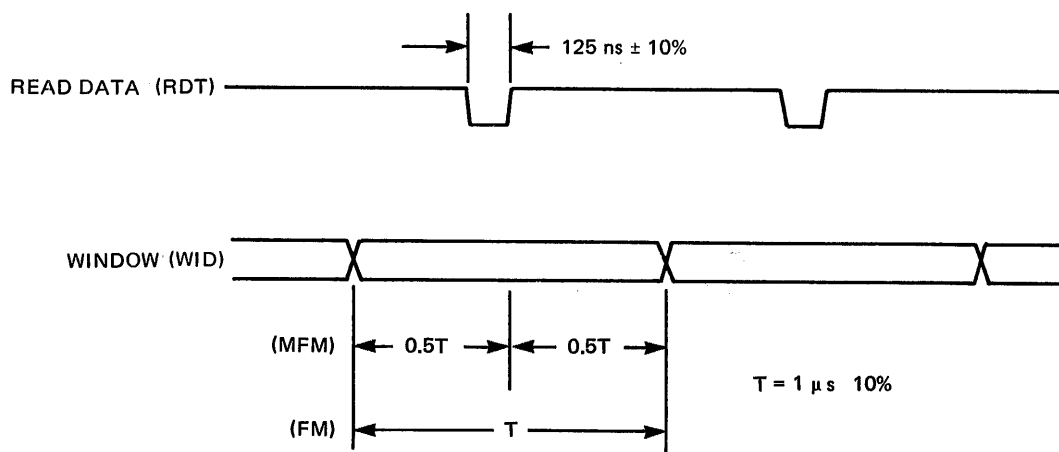

Figure 3-9 Read Data and Window Signal Timing

### 3.6 INTERFACE TIMING

This section describes the interface timing for the Model FD1165.

#### 3.6.1 Power On Sequence

The FD1165 processes valid I/O signals 700 ms after the door is closed.

#### 3.6.2 Drive Select

The disk drive processes valid I/O signals 500 ns after the Drive Select line (DX) goes Low.

#### 3.6.3 Step and Track 00

Figure 3-10 shows the required time relationship between the Step signal from the controller and the Track 00 output signal.

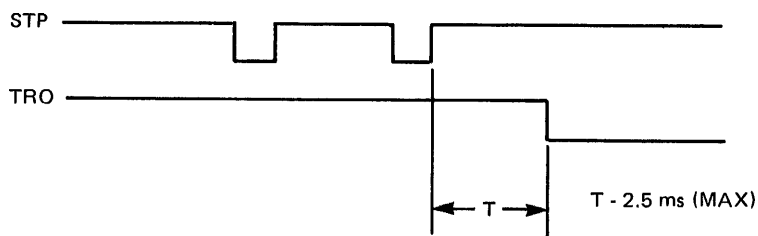

Figure 3-10 Step and Track 00 Timing



### 3.6.4 Access

Figure 3-11 shows the required time relationships between the Write Gate, Step, and Direction Select signals.

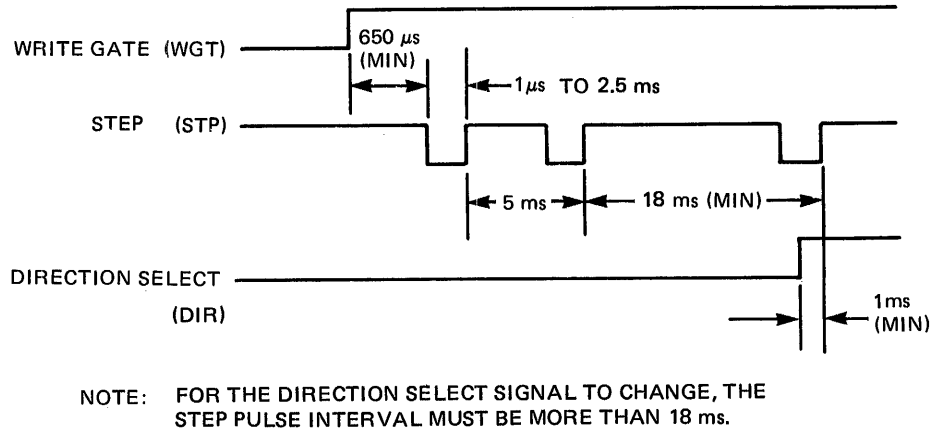

Figure 3-11 Access Timing

### 3.6.5 Write

Figure 3-12 shows the required time relationships of controller signals during a Write operation.

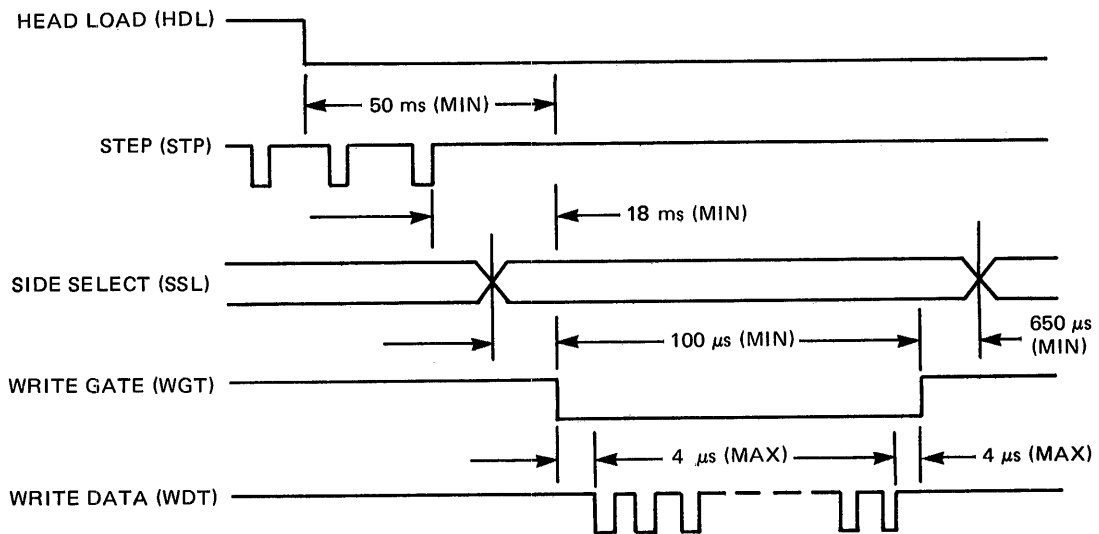

Figure 3-12 Write Timing

### 3.6.6 Read

Figure 3-13 shows the time relationships of controller signals during a Read operation.

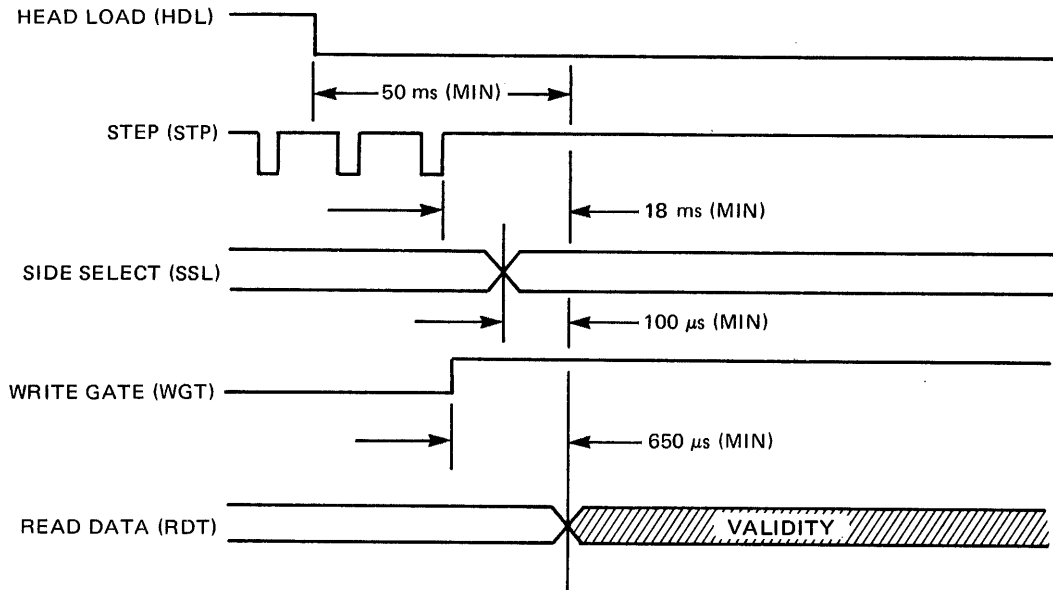

Figure 3-13 Read Timing

## CHAPTER 4

### MAINTENANCE

This chapter describes the maintenance procedures for the Model FD1165. If the disk drive proves defective in the field, it should be exchanged for another unit and the defective unit should be sent to a depot repair facility for repair. The removal and replacement procedures in this chapter and the adjustment procedures in Chapter 5 are used for depot repair.

#### 4.1 PREVENTIVE MAINTENANCE

Use a soft lint-free cloth to remove dust or foreign material from around the insertion slot and from the front panel of the disk drive.

#### 4.2 MAINTENANCE TOOLS

In addition to the standard maintenance tools (oscilloscope, screwdriver, feeler gauge, and so on) several special maintenance tools (see Table 4-1) are required to service the FD1165.

Table 4-1 Maintenance Tools

TOOL	NEC PART NUMBER
Disk Drive Tester	134-190336-0
Adjusting Driver	134-190337-0
Alignment Flexible Disk	806-944184-0
Index Sensor Adjusting Pin	134-190338-0
Collet Assembly Adjusting Jig	134-190339-0
Head-Cleaning Flexible Disk	134-190340-0

#### 4.3 MAINTENANCE PARTS

The parts that are listed in Table 4-2 should be stocked at maintenance depots.

Table 4-2 Maintenance Parts

PART DESCRIPTION	PART NUMBER	QUANTITY PER DISK DRIVE
Collet Assembly	134-132343-0	1
Carriage Assembly	134-132344-0	1
Head Load Cam Assembly	134-132362-0	1
Sensor (Media-in, Write Protect or Optical Tachometer)	134-132502-0	3
Sensor Cable Assembly (includes LED Assembly and Index Sensor)	134-132360-0	1
Carbon Brush	806-942306-006-0	2
Front Panel (Black)	134-147098-002-A	1
Picker Rod	134-147109-0	1
Pop-Up Assembly	134-132355-0	1
Guide Rail	134-132358-0	1
Display Lamp Assembly	134-132357-0	1
Door Handle (Black)	134-147102-002-A	1
00 Track Sensor Assembly	134-132361-0	1
Spindle Assembly	134-132341-0	1
Head Load Cam	134-147097-0	1
G9NYF PCB Assembly	134-835102-0	1

#### 4.4 REMOVAL AND REPLACEMENT PROCEDURES

This section describes the part removal procedures for the Model FD1165. The replacement procedures are the reverse of the removal procedures, unless noted. Mechanical adjustments are included with the removal and replacement procedures. If electrical adjustment is required after replacement, a reference is given to the appropriate section of Chapter 5.

##### 4.4.1 PCB Removal

Use the following procedure to remove the PCB.

- a. Disconnect all the connectors from the PCB.
- b. Remove the four screws that hold the PCB to the base frame.
- c. Lift the PCB out of the base frame.

#### 4.4.2 Collet Assembly Removal, Replacement, and Adjustment

Use the following procedure to remove the collet assembly.

- a. Remove the two screws that fasten the head unload spring to the spring plate and remove the head unload spring (see Figure 4-1).
- b. Remove the four screws that fasten the spring plate and the press plate to the base frame.
- c. Remove the collet assembly from the base frame.

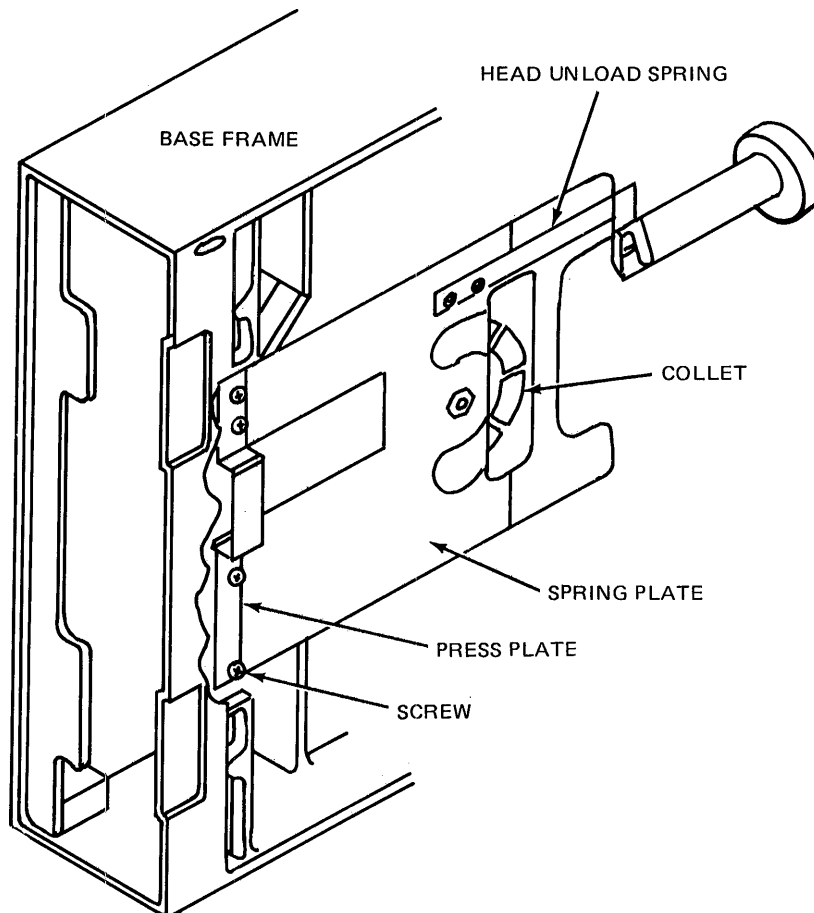

Figure 4-1 Removing the Collet Assembly

Use the following procedure to replace and check the collet assembly.

- a. Fit the collet assembly adjusting jig to the new collet assembly, then fit the collet assembly to the disk drive. Do not fully tighten the screws.

- b. Insert a dummy flexible disk into the disk drive and gently close the door handle so that the collet fits into the spindle.
- c. Tighten the four screws.
- d. Replace the head unload spring. The clearance between the arm on the head load cam and the head unload spring should be 0 to .008 inches (0 to 0.2 mm) (see Figure 4-2).

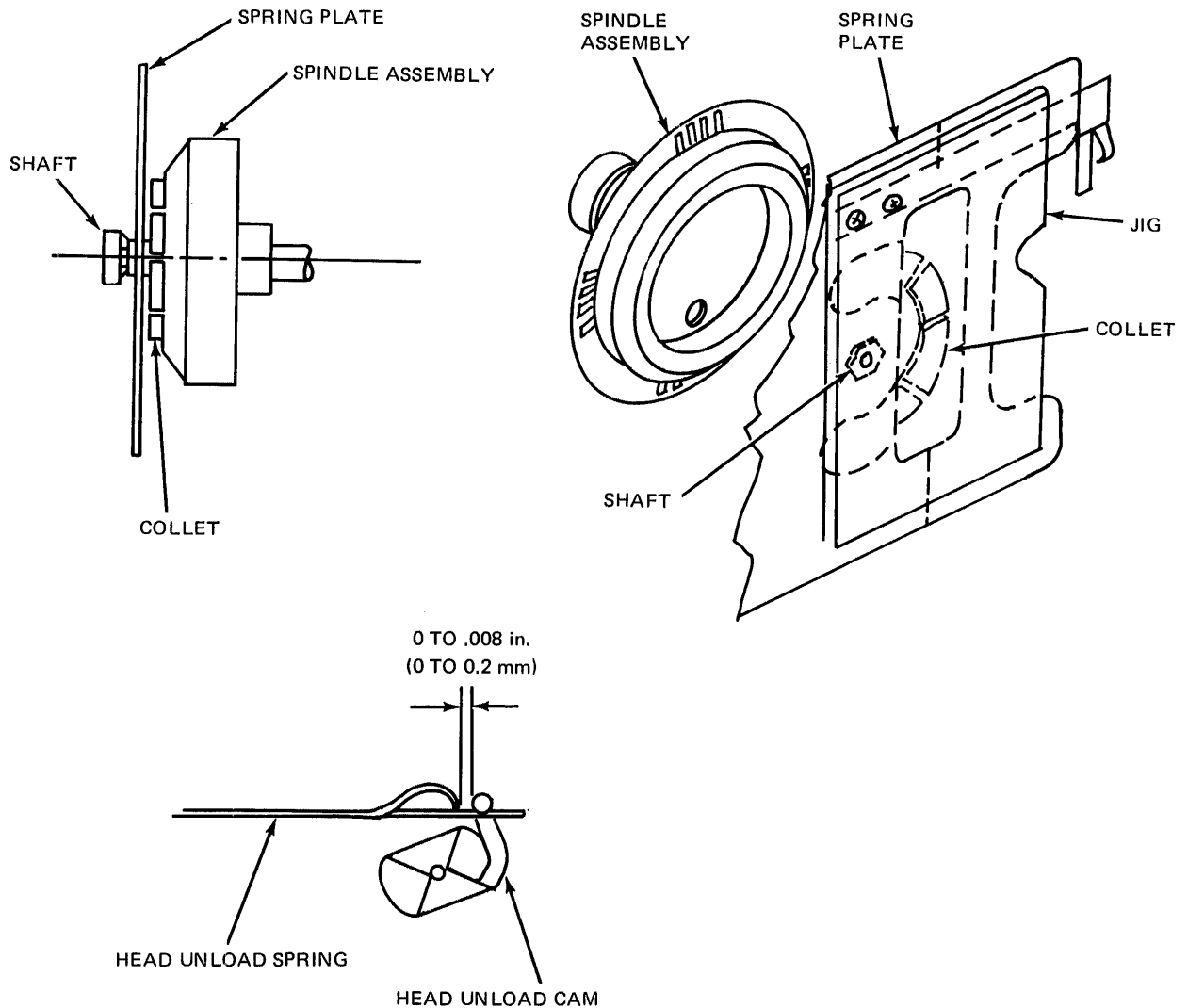

Figure 4-2 Replacing the Collet Assembly

- e. After the collet assembly is in place, check that there is no clearance between the head unload spring and the spring plate (see Figure 4-3). If there is clearance, replace collet assembly with a new one.

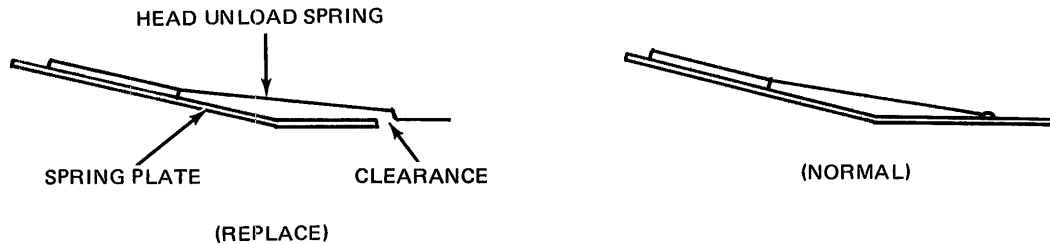

Figure 4-3 Head Unload Spring in Relation to Spring Plate

If the clearance between the head unload spring and the spring plate is within specifications, check the position of the spring plate as follows.

- a. Make sure that the head load cam is in the unload position.
- b. Insert a flexible disk into the drive until the disk locks in place; remove the flexible disk and close the door.
- c. Check with a feeler gauge that the clearance between the spring plate and the surface of the base frame is .044 to .060 inches (1.1 to 1.5 mm) (see Figure 4-4).

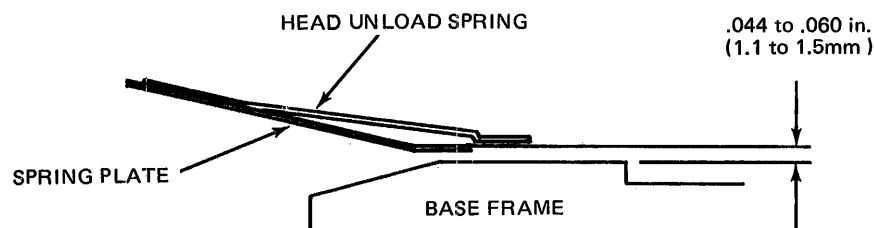

Figure 4-4 Position of the Spring Plate

- d. Open the door of the disk drive, insert a flexible disk, and close the door.
- e. Check on the stepping motor side of the disk drive that the spring plate does not contact the jacket of the flexible disk.
- f. If the specifications in Step c and Step e cannot be met, replace the collet assembly.

After checking the head unload spring and spring plate, check the timing relationship between disk ejection and head unloading as follows.

- a. Move the carriage to the outer track, insert a flexible disk, and close the door.
- b. Rotate the head load cam to load the heads.
- c. Open the door, making sure that the heads unload before the flexible disk "pops up."
- d. Make sure that the flexible disk does not contact the heads during ejection.

#### 4.4.3 Carriage Assembly Removal and Replacement

Use the following procedure to remove the carriage assembly.

- a. Remove the PCB.
- b. Trace the wiring to the carriage assembly and free the wiring from the plastic clips that secure the wiring to the base frame.
- c. Remove the wiring, through the base frame, toward the carriage assembly.
- d. Remove the screws that secure the metal clips to the base frame and remove the clips (see Figure 4-5).
- e. Remove the two screws that secure the carriage assembly to the base frame, separate the carriage assembly from the base frame, then remove it.



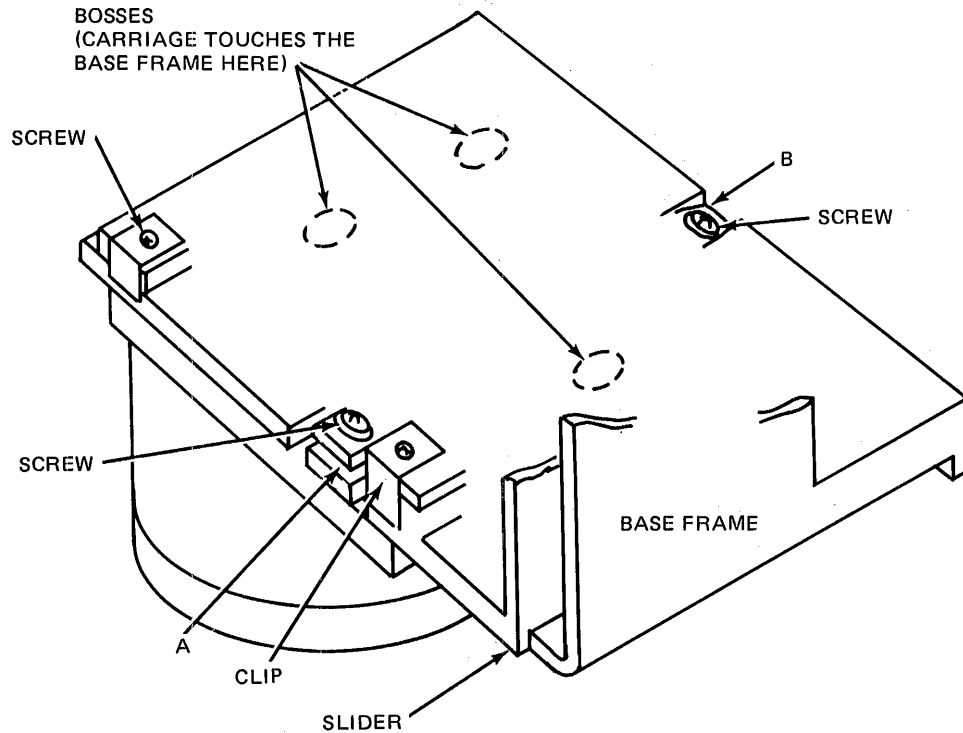

Figure 4-5 Carriage Assembly Position on the Base Frame

Use the following procedure to replace the carriage assembly.

- a. Fit the carriage assembly into the base frame.
- b. Hold the carriage assembly against the side of the base frame and measure the gap at points A and B in Figure 4-5.
- c. Select two spacers to insert into the gaps.

NOTE

Determine the size of the spacers as follows. The spacer for gap A is the measured value minus .016 inches (0.4 mm). The spacer for gap B is the measured value minus .012 inches (0.3 mm). If the measured values are .016 inches (0.4 mm) and .012 inches (0.3 mm) (or less) respectively, no spacers are needed.

- d. Insert the spacers and loosely install the screws.
- e. Install the spring clips.

- f. Check that the three boss surfaces are in contact (see Figure 4-5).
- g. Perform the head radial alignment adjustment (see Section 5.4.1).

#### 4.4.4 Head Load Cam Assembly and Head Load Cam Removal and Replacement

Use the following procedure to remove the head load cam assembly.

- a. Remove the PCB.
- b. Trace the wiring harness to the head load cam assembly and separate the wiring harness from the clips that fasten it to the base frame.
- c. Remove the three screws that secure the head load cam assembly to the base frame.
- d. Turn the head load cam to the unload position.
- e. Holding the head load cam assembly by the bracket, remove it from the base frame by moving it clockwise.

To remove the head load cam, remove the screw that secures it to the rotary solenoid (see Figure 4-6).

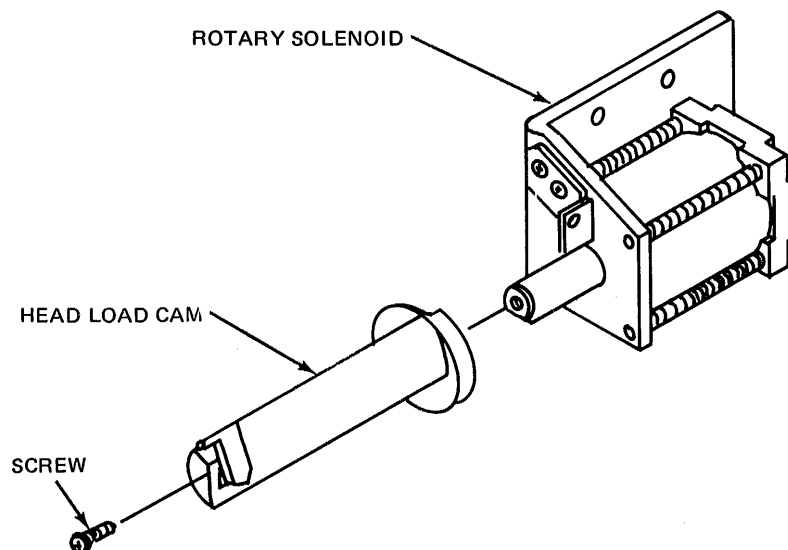

Figure 4-6 Removing the Head Load Cam

To replace the head load cam assembly,

- a. Hold the head load cam assembly against the reference surface of the base frame and install the screws (see Figure 4-7).
- b. Run the wiring harness through the base frame and fasten it to the base frame with the appropriate clips.
- c. Replace the PCB.

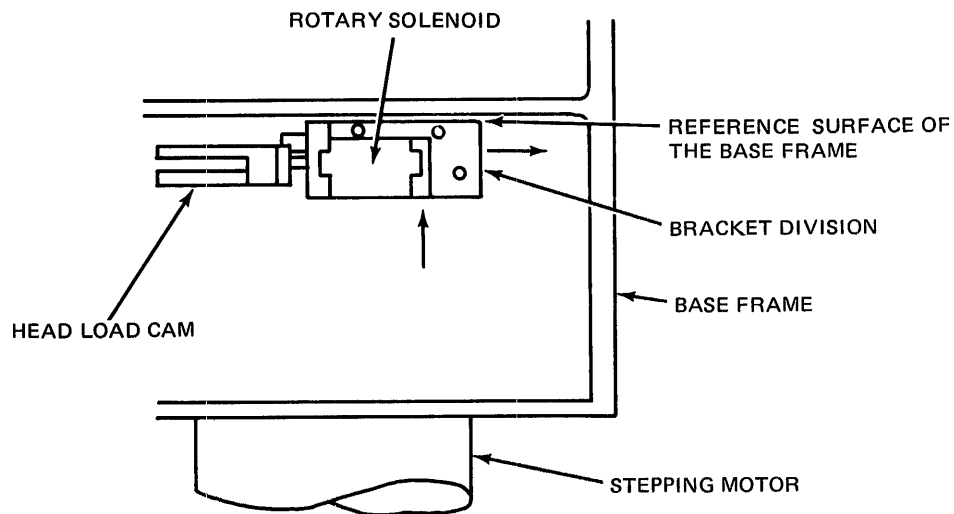

Figure 4-7 Installing the Head Load Cam Assembly

#### 4.4.5 Write Protect Sensor and Media-In Sensor Removal and Replacement

Use the following procedure to remove either sensor.

- a. Removing the screw that fastens the sensor to the base frame assembly.
- b. Remove the heat-shrinkable tubing from the sensor connections and unsolder the wires (see Figure 4-8).

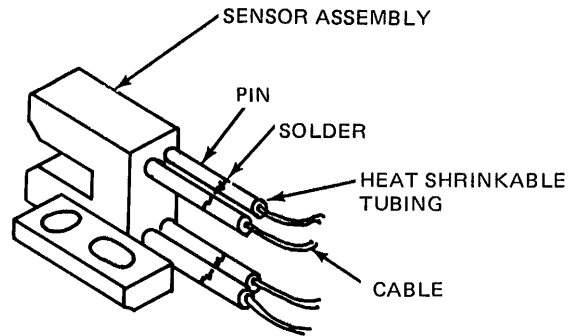

Figure 4-8 Write Protect or Media-In Sensor Connections

Use the following procedure to replace either sensor.

- a. Reverse the removal procedure, but do not tighten the screw.
- b. Push the sensor towards the front of the disk drive until the shaft of screw touches the rear of the elongated hole in the sensor (see Figure 4-9).
- c. Tighten the screw.

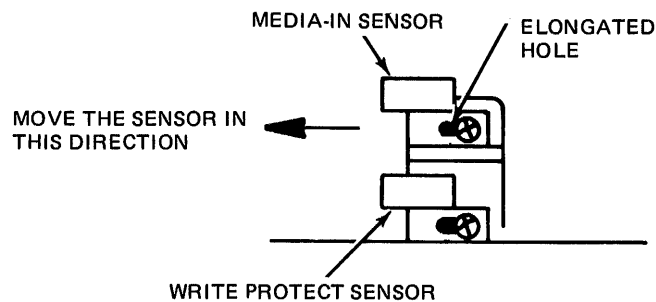

Figure 4-9 Installing the Write Protect or Media-In Sensor

#### 4.4.6 Optical Tachometer Sensor Removal and Replacement

Use the following procedure to remove the optical tachometer sensor.

- a. Remove the collet assembly.
- b. Remove the screw that fastens the sensor to the base frame.

- c. Slide the sensor out of the base frame, being careful not to damage the encoder (see Figure 4-10).
- d. Remove the heat-shrinkable tubing from the sensor connections and unsolder the wires.

Use the following procedure to replace the optical tachometer sensor.

- a. Reverse the removal procedure; do not tighten the screw.
- b. Slide the sensor into the channel in the base frame until the gap between the spindle and the sensor is .008 to .040 inches (0.2 to 1.0 mm) (see Figure 4-10).
- c. Replace the collet assembly.
- d. Tighten the screw.

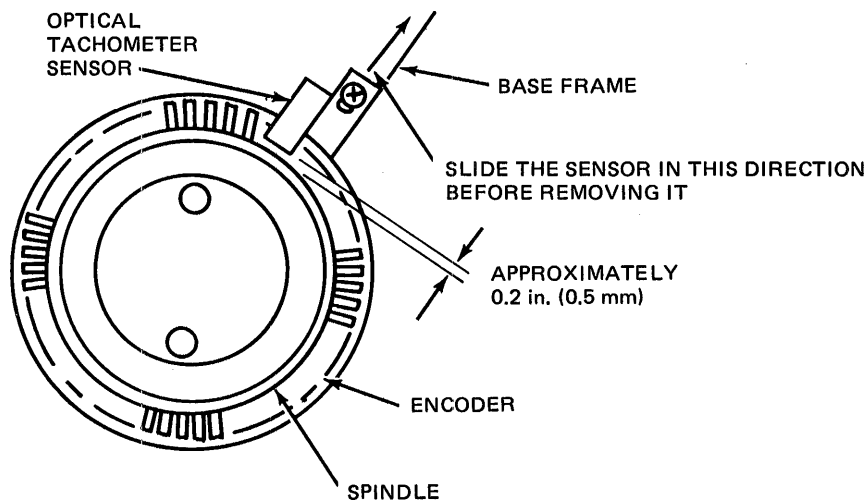

Figure 4-10 Removing and Replacing the Optical Tachometer Sensor

#### 4.4.7 Sensor Cable Assembly (LED Assembly and Index Sensor) Removal and Replacement

The LED assembly and index sensors are replaced as a sensor cable assembly.

Use the following procedure to replace the sensor cable assembly.

- a. Remove the lever plate by removing the four screws that fasten it to the two lever hinges (see Figure 4-11).

- b. Remove the collet assembly.
- c. Separate the sensor cable connector from the PCB and slide the connector through the hole in the base frame.
- d. Remove the two screws that fasten the LED assembly to the base frame.
- e. From the PCB side of the disk drive, remove the single screw that fastens the index sensor to the base frame.

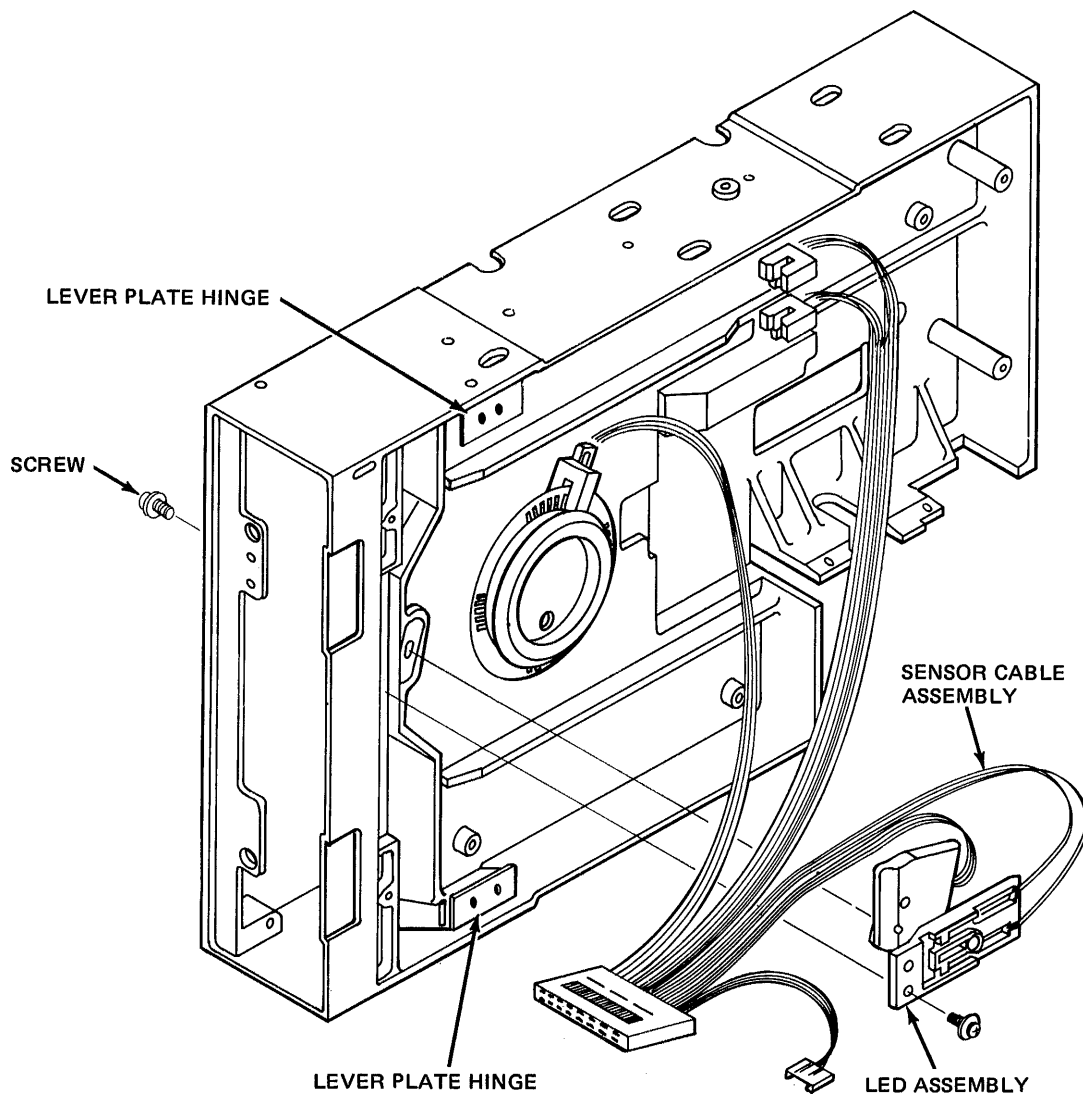

Figure 4-11 Removing the Sensor Cable Assembly

- f. Separate the connector to the 00 track sensor.
- g. Remove the heat-shrinkable tubing and unsolder the connections of the media-in sensor, the write protect sensor, and the optical tachometer sensor.
- h. Separate the sensor cable assembly from the base frame by spreading the clips that fasten the sensor cable to the base frame.
- i. Remove the sensor cable assembly from the base frame with the LED assembly and index sensor attached.

Use the following procedure to install and adjust the index sensor.

- a. Insert the index sensor into the index sensor groove in the base frame.
- b. Install the screw that fastens the sensor to the base frame but do not tighten it.
- c. Insert the index sensor adjusting pin into the hole in the index sensor.
- d. Push the index sensor so that the adjusting pin touches the adjusting surface of the base frame (see Figure 4-12).
- e. Tighten the screw that fastens the index sensor to the base frame. Do not remove the adjusting pin.

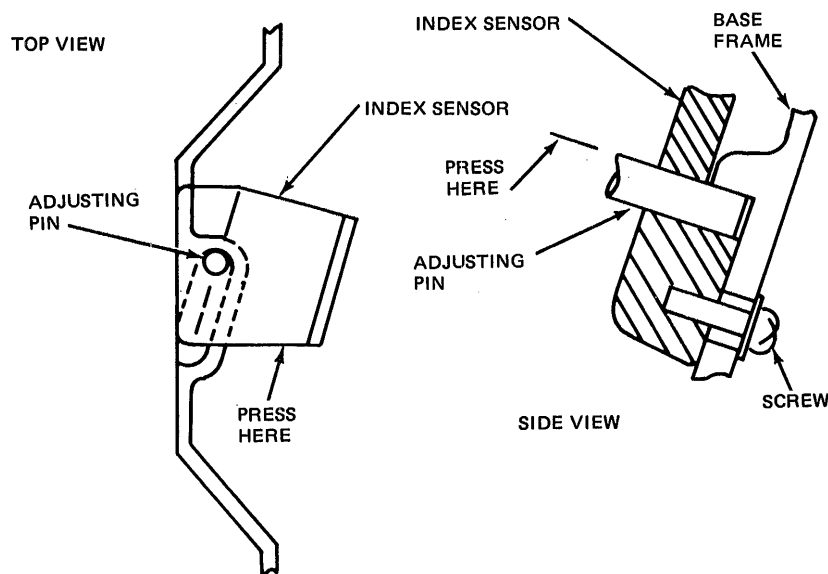

Figure 4-12 Installing the Index Sensor

Use the following procedure to install the LED Assembly.

- a. Install the LED assembly so that the hole in the LED unit fits over the adjusting pin.
- b. Install the two screws that fasten the LED assembly to the base frame (see Figure 4-11).
- c. Remove the adjusting pin.
- d. Perform the index alignment adjustment (see Section 5.4.3).

#### 4.4.8 Removing and Replacing the Carbon Brushes

Use the following procedure to remove a carbon brush,

- a. Remove the brush stopper (see Figure 4-13).
- b. Remove the brush.

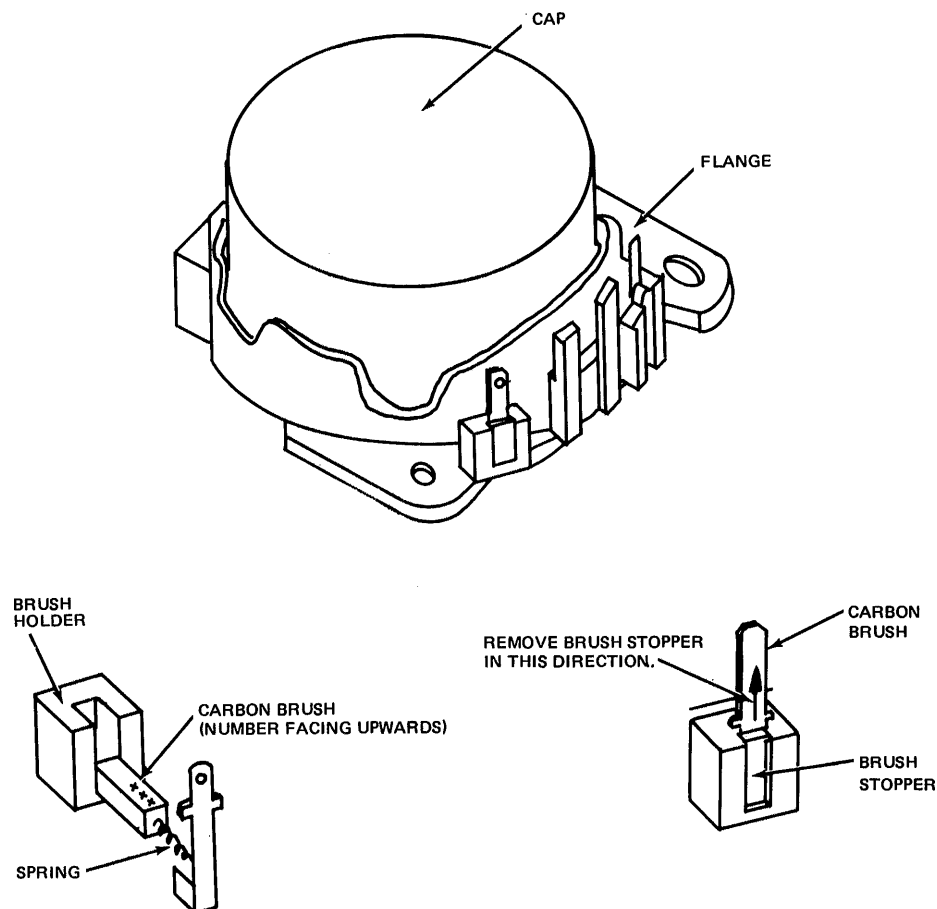

Figure 4-13 Removing a Carbon Brush



Use the following procedure to replace a carbon brush.

- a. Insert the carbon brush with the identification number facing upwards (see Figure 4-13).
- b. Insert the brush stopper.

#### 4.4.9 Armature Removal

Use the following procedure to remove the armature.

- a. Remove the PCB.
- b. Insert two nonmagnetic screwdrivers between the magnet cap and the motor flange as shown in Figure 4-14.

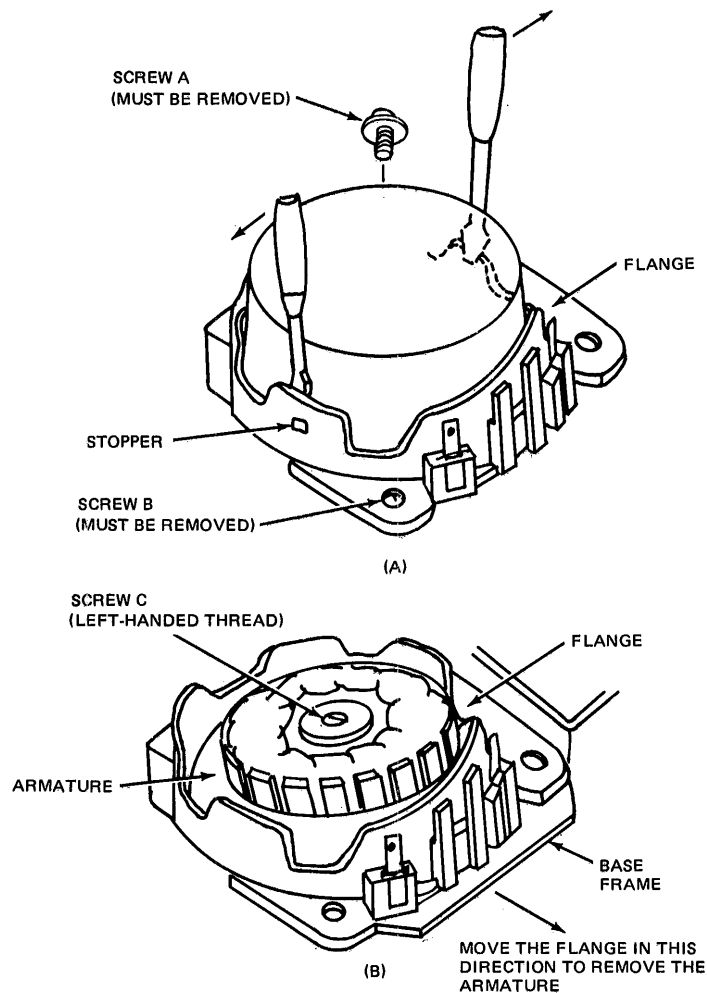

Figure 4-14 Removing the Armature

- c. Pick up the magnet cap slowly and evenly (it is highly magnetized).
- d. If the carbon brushes are installed, remove the screws A and B (see Figure 4-14) that hold the motor flange, loosen screw C, and move the flange toward the front of the disk drive to take pressure off of the carbon brushes.
- e. Remove the spindle screw (left-handed thread) and lift the armature up to remove it.

#### 4.4.10 Spindle Assembly Removal

Use the following procedure to remove the spindle assembly.

- a. Remove the armature.
- b. Remove the optical tachometer sensor.
- c. Turn the spindle until the two holes in the spindle line up with the screws that fasten the spindle assembly to the base frame.
- d. Remove the two screws (see Figure 4-15) and lift the spindle assembly out of the base frame.

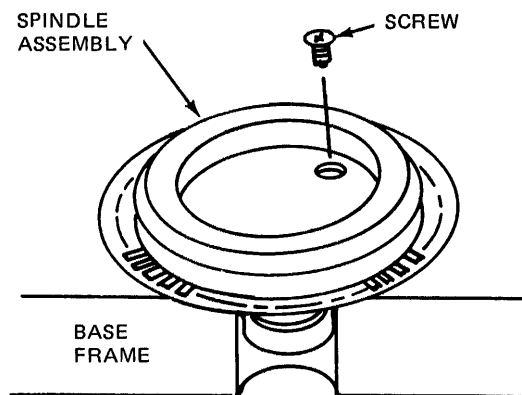

Figure 4-15 Removing the Spindle Assembly

#### 4.4.11 Front Panel Removal

Use the following procedure to remove the front panel.

- a. Remove the two screws that fasten the front panel to the base frame (see Figure 4-16).
- b. Pinch the two panel latches (see Figure 4-16) and remove the front panel.

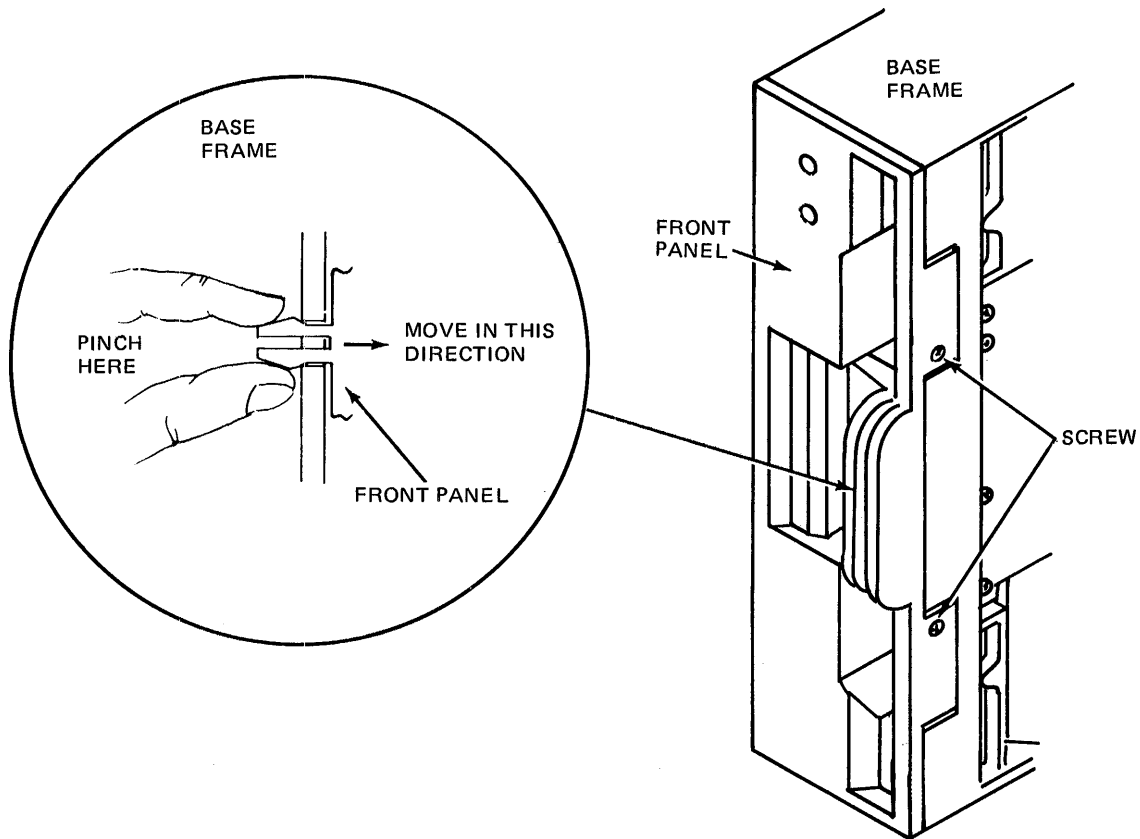

Figure 4-16 Removing the Front Panel

#### 4.4.12 Picker Rod Removal and Replacement

To remove the picker rod, remove the screw that fastens the picker rod to the handle plate.

Use the following procedure to replace the picker rod.

- a. Install the picker rod; do not tighten the screw.
- b. Adjust the clearance between the picker rod and the picker rod holder to 0.04 to 0.06 inches (1 to 1.5 mm) (see Figure 4-17).

- c. Tighten the screw.
- d. Check the operation of the picker rod (see Section 4.4.15).

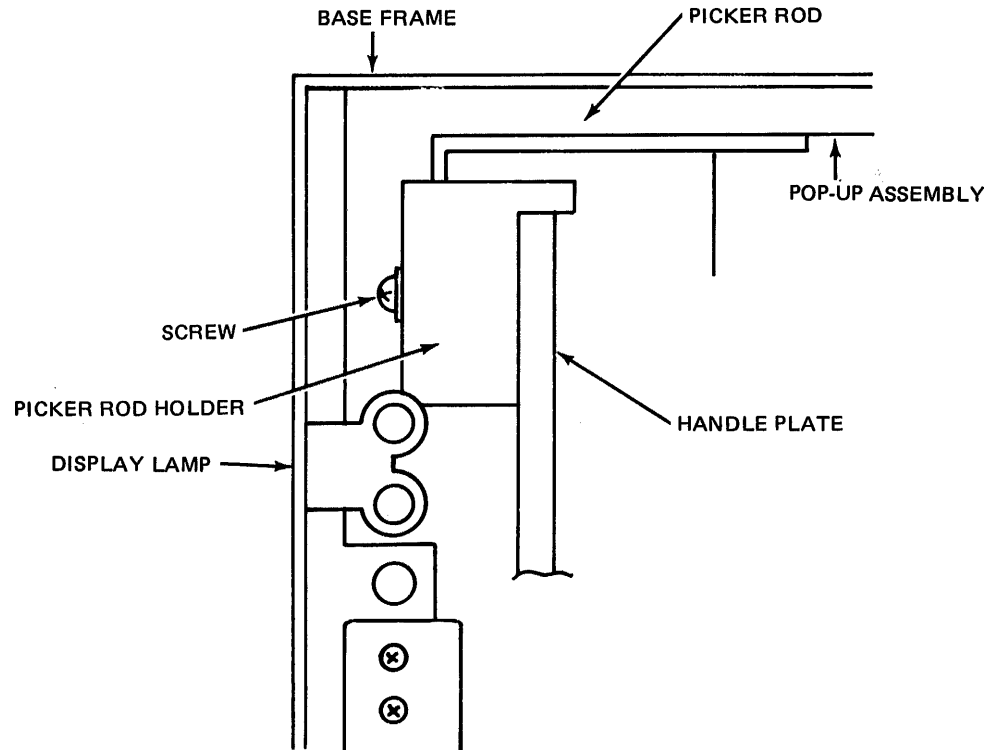

Figure 4-17 Adjusting the Picker Rod

#### 4.4.13 Pop-Up Assembly Removal and Replacement

Use the following procedure to remove the pop-up assembly.

- a. Remove the lever plate by removing the four screws that secure it to the lever plate hinges.
- b. Loosen the pop-up assembly by removing the two screws that fasten it to the base frame (see Figure 4-18).
- c. Move any wiring that is in the way and lift the pop-up assembly out of the base frame.

Use the following procedure to replace the pop-up assembly.

- a. Install the pop-up assembly into the base-frame, being careful not to damage the picker rod.
- b. Check the operation of the pop-up assembly (see Section 4.4.15).

#### 4.4.14 Guide Rail Removal

Use the following procedure to remove the guide rail.

- a. Remove the lever plate by removing the four screws that secure it to the lever plate hinges.
- b. Remove the two screws that fasten the guide rail to the frame (see Figure 4-18).
- c. Remove the guide rail.

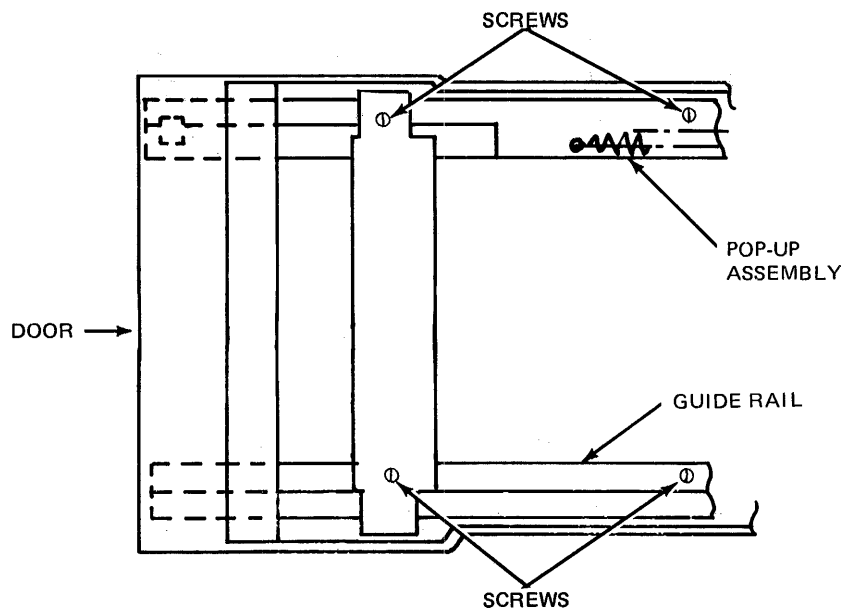

Figure 4-18 Removing the Pop-Up Assembly and Guide Rail

#### 4.4.15 Checking the Operation of the Pop-Up Feature

After replacing the picker rod or the pop-up assembly, check the operation of the pop-up feature as follows.

- a. Turn on the power supply for the disk drive.
- b. Insert the flexible disk and make sure that the pop-up feature locks in place.
- c. Close the door of the disk drive.

- d. Open the door and make sure that the disk drive ejects the flexible disk about 1/2-inch (13 mm).
- e. Insert a dummy flexible disk and close the door.
- f. Hold the disk in place by hand.
- g. Open and close the door about 10 times to insure that the door operates correctly.

#### 4.4.16 Door Lock Solenoid Removal and Replacement

Use the following procedure to remove the door lock solenoid.

- a. Remove the front panel
- b. Remove the two screws that fasten the door lock solenoid and bracket to the base frame.
- c. Trace the wire to the door lock solenoid and separate the wire from the clips that secure it to the base frame.
- d. Unplug the wire of the door lock solenoid at the PCB.
- e. Remove the door lock solenoid.

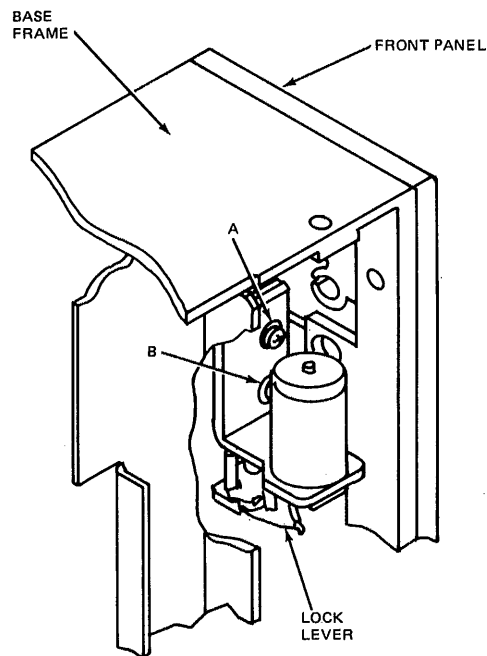

Figure 4-19 Removing the Door Lock Solenoid

To replace the door lock solenoid, reverse the removal procedure, then do the following.

- a. Lock the door and activate the solenoid by pushing in at the end of the solenoid that is opposite the shaft.
- b. Make sure that the clearance between the solenoid shaft and the lock lever is  $0.02 \pm .006$  inches ( $0.5 \pm 0.15$  mm) (see Figure 4-20A). To adjust this value, loosen the screws that fasten the door handle to the handle plate, then move the handle to change the position of the lock lever, and tighten the screws.

If even greater adjustment is needed loosen screws A and B (see Figure 4-19), move the door lock solenoid, and tighten the screws.

- b. Make sure that the lock pin protrudes beyond the lock lever  $0.06 \pm .006$  inches ( $1.5 \text{ mm} \pm 0.15 \text{ mm}$ ) (see Figure 4-20B). Adjust this value by moving the door handle.
- c. With the solenoid activated the clearance from the edge of the lock lever to the tip of the shaft of the solenoid is  $0.03 \pm .006$  inches ( $0.7 \text{ mm} \pm 0.15 \text{ mm}$ ) (see Figure 4-20B).

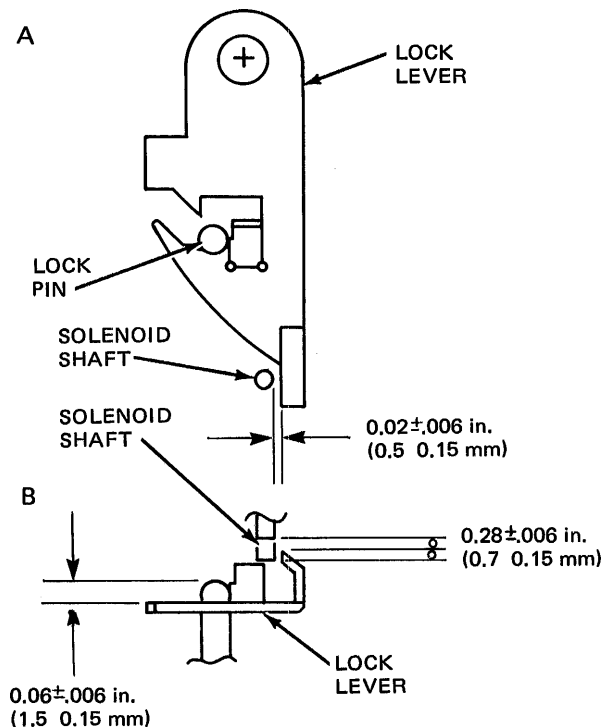

Figure 4-20 Adjusting the Door Lock Solenoid





## CHAPTER 5 ADJUSTMENTS

This chapter describes the diagnostic tests, adjustment procedures, and checks for the Model FD1165.

### 5.1 DIAGNOSTIC TESTS

This section describes the diagnostic tests for the Model FD1165. Diagnostic tests are performed using of diagnostic test pins T2 and T3 (see Figure 5-1). The FD1165 is supplied with the test pins open (not connected).

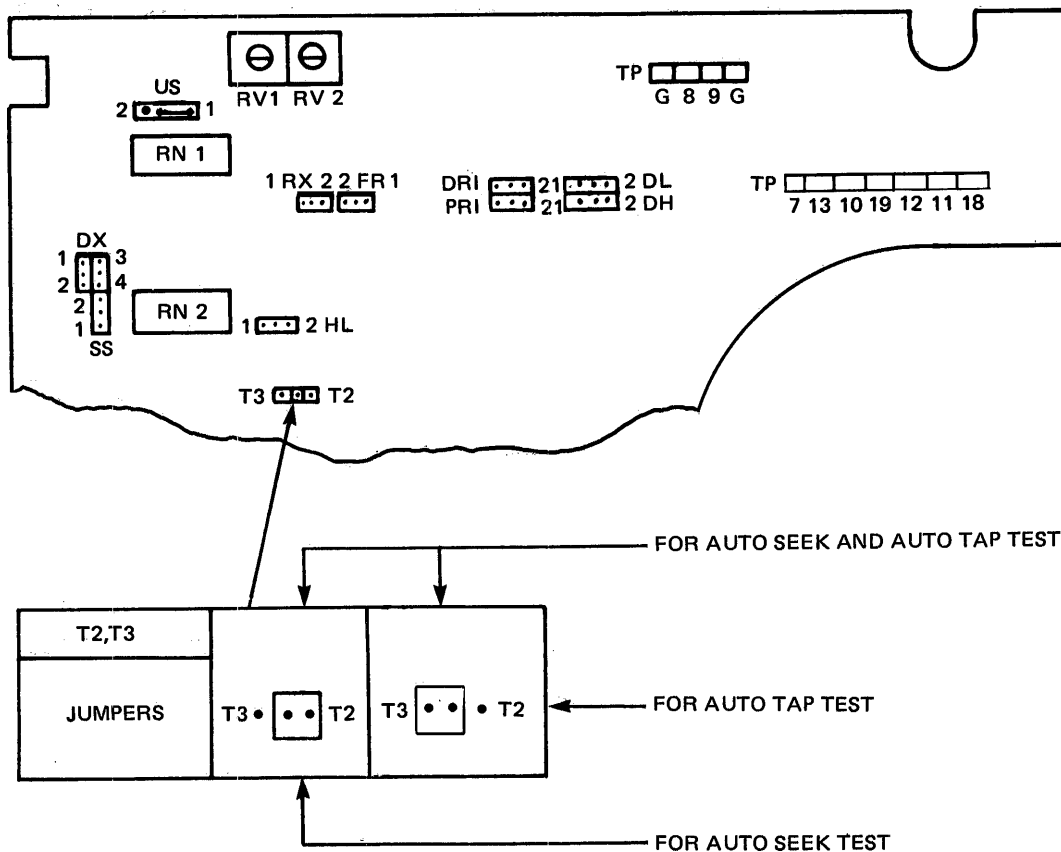

Figure 5-1 Location of Diagnostic Test Pins and Test Points

### 5.1.1 Auto Tap Test

The auto tap test consists of a head load/head unload action. To initiate the auto tap test, use the following procedure.

- a. Turn off the power to the disk drive.
- b. Connect diagnostic pin T2 to the center pin.
- c. Select head load jumper position HL2 and connect HL2 to ground.
- d. Turn on the power to the disk drive to start the auto tap test.

### 5.1.2 Auto Seek Test

The auto seek test consists of a continuous track seek, from track 0 to track 76, with the read/write heads unloaded. Select the auto seek test as follows.

- a. Turn off the power to the disk drive.
- b. Connect diagnostic pin T3 to the center pin.
- c. Turn on the power to the disk drive to start the auto seek test.

### 5.1.3 Auto Seek and Auto Tap Test

The auto seek and auto tap test performs the auto seek and auto tap functions simultaneously. Select the auto seek and auto tap test as follows.

- a. Turn off the power to the disk drive.
- b. Connect diagnostic pins T2 and T3 to the center pin.
- c. Select head load jumper position HL2 and connect HL2 to ground.
- d. Turn on the power to the disk drive to start the auto seek and auto tap test.

## 5.2 HEAD UNLOAD DELAY

To delay the head unload action by 250 ms, short pin T1 (see Figure 5-1) to ground. With T1 shorted to ground, rapid head load/unload actions (less than 250 ms apart) cannot occur. Normally this pin is open.

### 5.3 TEST POINTS

The test point (TP) numbers (see Figure 5-1) and the signals available at these points are listed in Table 5-1. Test points not listed in the table are used in manufacturing only.

Table 5-1 Test Points and Signals

PIN NUMBER	SIGNAL
TP7	Index signal for dual-sided flexible disks
TP8, TP9	Analog signal (differential) of head output, used to check or adjust CE, Azimuth, or Index
TP10	Index signal for single-sided flexible disks
TP11	Write Protect Signal
TP12	Track 00 Signal
TP13	Media detect sensor output

### 5.4 ADJUSTMENTS AND CHECKS USING THE ALIGNMENT FLEXIBLE DISK

Table 5-2 lists the adjustments and checks using the NEC Alignment Flexible Disk (Part Number, 806-944184-0) and indicates when the adjustments and checks should be performed.

Table 5-2 Adjustments

ADJUSTMENT OR CHECK	WHEN PERFORMED
Head Radial Alignment	After carriage assembly replacement
Azimuth	After carriage assembly replacement
Index	After index sensor replacement or after carriage assembly replacement

In addition to the usual care that should be taken with a flexible disk, take the following extra precautions with the alignment flexible disk.

- Before making adjustments, acclimate the flexible disk for one hour in the working environment.
- Keep the disk drive in the "power-on" status for one hour.
- Do not allow the flexible disk to remain immobile under a head load condition for long.
- Use the flexible disk in a temperature range of 68 to 78.5°F (20° to 26°C).

#### 5.4.1 Head Radial Alignment Check or Adjustment

Set the oscilloscope to the settings shown in Table 5-3, then perform the head radial alignment as follows.

Table 5-3 Head Radial Alignment Oscilloscope Settings

ITEM	SETTING
Channel 1	Normal
Channel 2	Inverted
Mode	Add
Inputs	Ac
Input range	100 mV/division
Test points	TP8 and TP9
Trigger	TP7 (dual-sided media) TP10 (single-sided media)
Time base	20 ms/division
Probes	x1 or x10

- a. Insert the alignment flexible disk and step the carriage (with the drive tester) from track 00 to track 38.
- b. Load the read/write heads for three minutes.

- c. Check the waveform (see Figure 5-2). The two lobes that are displayed should be within 70% of each other in amplitude.

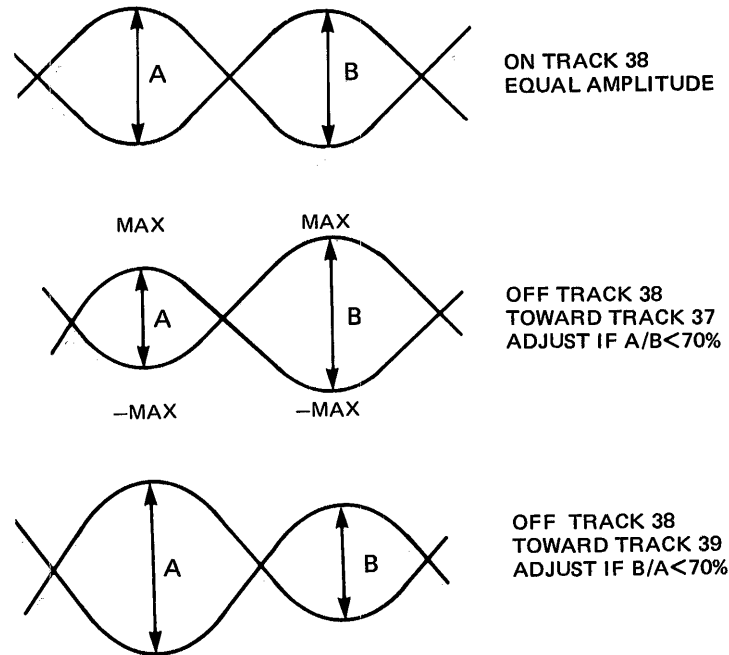

Figure 5-2. Head Radial Alignment Waveform

- d. If the ratio of the lobes of the waveform is not within specifications, loosen the two screws that fasten the carriage to the base frame and adjust the carriage position (in or out) with the adjusting driver (see Figure 5-3).
- e. Tighten the screws.
- f. Unload the heads, step the carriage to track 76 then step it back to track 38, and load the heads for three minutes.
- g. Recheck the waveform.
- h. If the waveform is within specifications, check the 00 track sensor (see Section 5.5.2).

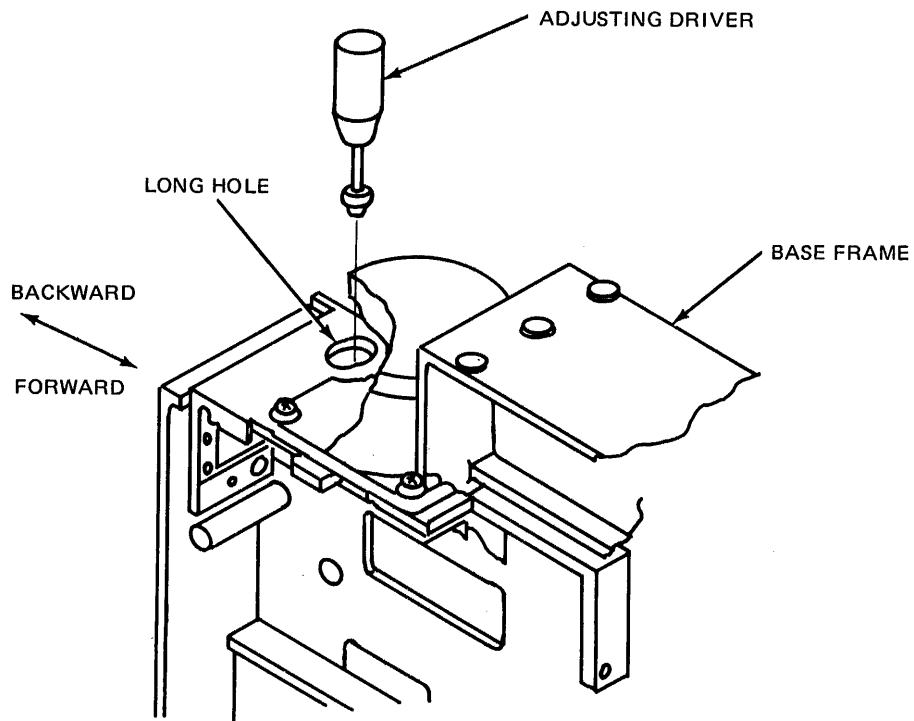

Figure 5-3 Adjusting Head Radial Alignment

#### 5.4.2 Azimuth Check

Carriage assembly replacement is usually required to correct Azimuth error. Set the oscilloscope to the settings in Table 5-4, then use the following procedure to check for Azimuth error.

Table 5-4 Head Azimuth Oscilloscope Settings

ITEM	SETTING
Channel 1	Normal
Channel 2	Inverted
Mode	Add
Inputs	Ac
Input range	50 mV/division
Test points	TP8 and TP9
Trigger	TP7 (dual-sided) TP10 (single-sided)
Time base	0.5 ms/division
Probes	x1

- a. Insert the alignment flexible disk and step the carriage to track 76.
- b. Load the heads.
- c. Compare the waveform in Figure 5-4 with the waveform that is displayed on the oscilloscope.
- d. If the waveform is not within specifications, replace the carriage assembly.

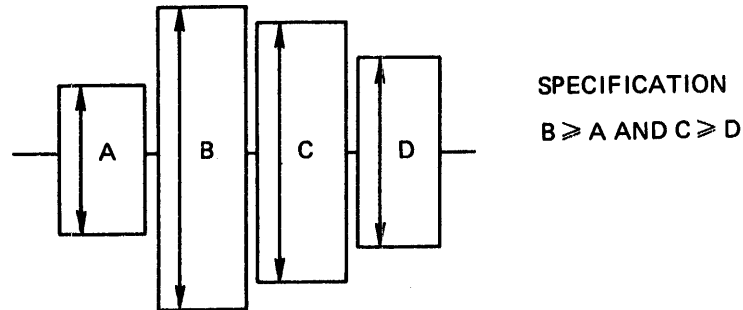

Figure 5-4 Azimuth Waveform

#### 5.4.3 Index Alignment Check or Adjustment

Set the oscilloscope to the settings in Table 5-5, then use the following procedure to check or adjust the Index alignment.

Table 5-5 Index Alignment Oscilloscope Settings

ITEM	SETTING
Channel 1	Normal
Channel 2	Inverted
Mode	Add
Inputs	Ac
Input range	200 mV/division
Test points	TP8 and TP9
Trigger	TP7 (dual-sided) TP10 (single-sided)
Time base	0.1 ms/division
Probes	x1

- a. Insert an alignment flexible disk.
- b. Step the carriage to track 01.
- c. Load the heads.
- d. Observe the timing between the trailing edge of the index pulse and the first peak of the read waveforms (see Figure 5-5). It should be  $200 \mu\text{s} \pm 200 \mu\text{s}$ .
- e. If the waveform does not meet this specification, adjust the index sensor as described in Section 4.4.7. If the LED assembly and the index assembly have been replaced, see Section 5.5.1.

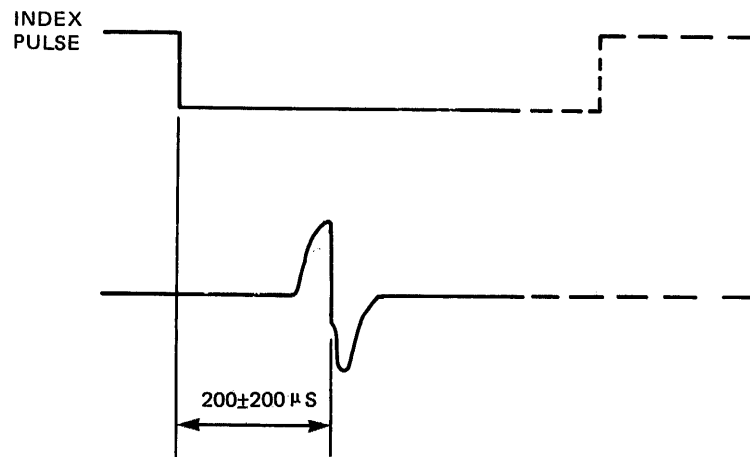

Figure 5-5 Index Alignment Waveform

## 5.5 OTHER ADJUSTMENTS

The checks and adjustments in this section do not require the use of the alignment flexible disk.

### 5.5.1 LED Assembly/Index Assembly Check and Adjustment

If the index sensor and LED assembly are replaced, perform the following check in addition to the index alignment adjustment.

- a. When using a single-sided flexible disk, measure the waveform at TP10, checking for a pulse width of 1 to 3 ms (see Figure 5-6).



- b. When using a dual-sided flexible disk, measure the waveform at TP7 checking for a pulse width of 1 to 3 ms (see Figure 5-6).
- c. If the waveform does not meet this specification, adjust the index sensor as in Section 4.4.7.

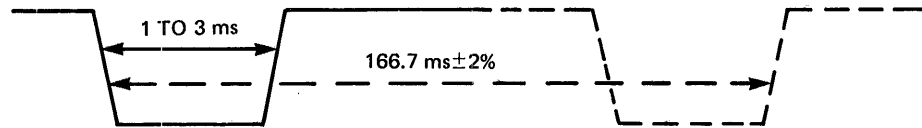

Figure 5-6 Waveforms at TP7 and TP10

### 5.5.2 00 Track Sensor Check or Adjustment

If the 00 track sensor in the carriage assembly is replaced, carry out the following procedure.

- a. Repeatedly perform a seek between track 0 and track 7 at a step time of 3 ms to 5 ms.
- b. Check that the Track 00 signal occurs within 2.0 ms to 2.5 ms of the Step signal to track 00 (see Figure 5-7).
- c. If the timing exceeds the specified value, loosen the installation screw of the 00 track sensor and move it inwards until the signal meets the specification (2.0 to 2.5 ms). Make sure that you do not move the sensor too much or it may identify track 2 as track 00.

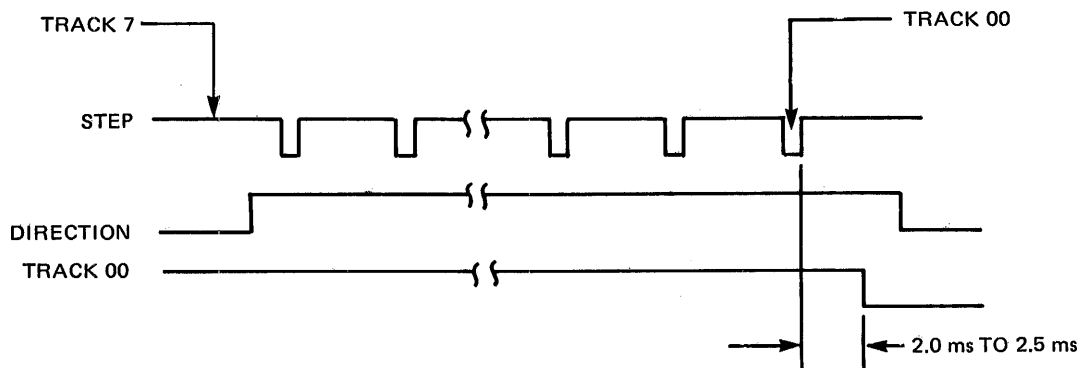

Figure 5-7 Track 00 Signal

### 5.5.3 Write Protect Sensor Check or Adjustment

After the write protect sensor is replaced, perform the following check.

- a. Insert a flexible disk that has a write protect notch into the disk drive.
- b. Check that the voltage at TP11 is less than 0.5 V. Move the jacket of the flexible disk to make sure that the voltage at TP11 does not change.
- c. If the voltage changes, loosen the screw that fastens the sensor and change the position of the sensor until the voltage does not change when the flexible disk is moved.
- d. Remove the flexible disk and insert a disk without a write protect notch.
- e. Check that the voltage at TP11 is more than 3.3 V. Move the jacket and make sure that the voltage does not change.
- f. If the voltage changes, change the position of the sensor until the voltage does not change when the jacket is moved.

### 5.5.4 Head Load Check

Perform this check after replacement procedures are performed.

- a. Write data of all 0s to an assigned track (using the drive tester).
- b. Load the heads and look at the read waveform.
- c. If the unstable area of the waveform is not within the specifications shown in Figure 5-8, replace the carriage assembly.

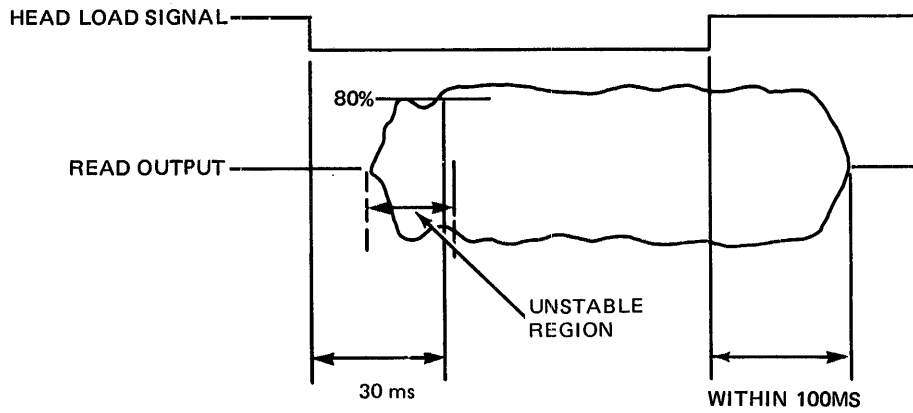

Figure 5-8 Head Load Waveform

## 5.6 TRIM POTS

There are three trim pots on the PCB of the Model FD1165. RV1 and RV2 determine the write current. They are adjusted at the factory and should never be adjusted in the field. RV3 determines the speed of the spindle motor. This trim pot is adjusted for an index pulse width of  $166.6 \pm 0.5$  ms.



## CHAPTER 6

### ILLUSTRATED PARTS BREAKDOWN

This chapter identifies the major parts of the flexible disk drive and contains a mechanical illustrated parts breakdown (IPB) and a PCB IPB.

The mechanical IPB is arranged in four columns.

- Item - contains the item numbers referred to in the callouts on the exploded view.
- Part Number - contains the NEC part number you use for ordering spares or replacement parts.
- Description - contains a brief description of the part. Parts and assemblies are listed followed by the attaching hardware. Screws, nuts, and washers are described in coded form.
- Quantity - contains the number of items per assembly.

The components of the PCB are listed in a four column format.

- Component Designation - contains the reference designation identifying the part on the PCB and on logic/schematic diagrams, in alphanumeric order.
- Part Number - contains the NEC part number to use when ordering spare or replacement parts.
- Description - contains a brief description of the part.
- Quantity - contains the number of items per assembly.

Screws, nuts, washers, and other standard fastening hardware are described in coded form. For example:

CPIMS x 3 x 6 x 15BF  
|        |        |        |  
a.        b.        c.        d.

Galvanized pan-head metric screw with cross groove, with nominal diameter of 3 mm and length of 6 mm.

The code is interpreted as follows.

a. Head code.

CP○MS : Pan-head metric screw with cross groove  
CF○MS : Flat-head metric screw with the cross groove  
AHEX○N : A-type hexagon nut  
BHEX○N : B-type hexagon nut  
S○WA : Small washer  
P○WA : Polished washer  
#2○LWA : Spring washer  
  
L-CP○MS  
S-CP○MS  
P-CP○MS SEMUSU screw (see Item e)  
SL-CP○MS  
PL-CP○MS

The symbol ○ is replaced by one of the following codes to show the material type that is used.

I = Iron  
B = Brass  
ST = Spring Steel

b. Nominal diameter in mm.

c. Length in mm. (Not used for nuts and washers.)

d. Finish. For example:

15BF - Galvanization, lustrous coloration,  
chromate finishing.

3GF - Lustrous nickel-plated finishing.

e. The SEMUSU screw is always provided with a washer as shown in the following examples.

L-CP $\bigcirc$ MS: Pan-head metric screw with cross groove plus spring washer

P-CP $\bigcirc$ MS: Pan-head metric screw with cross groove plus polished washer

S-CP $\bigcirc$ MS: Pan-head metric screw with cross groove plus small washer

PL-CP $\bigcirc$ MS: Pan-head metric screw with cross groove plus spring washer plus polished washer

SL-CP $\bigcirc$ MS: Pan-head metric screw with cross groove plus spring washer plus small washer

Table 6-1 List of Illustrations

FIGURE NUMBER	TITLE	PART NUMBER
6-1	FD1165 Flexible Disk Drive	134-100390-GRP-A
6-2	G9NYF PCB Assembly	134-835102-A

## 134-100390-GRP-A FD1165 Flexible Disk Drive

ITEM	PART NUMBER	DESCRIPTION	QTY
1	134-132359-0	Spindle Motor Assembly	1
2	806-942306-006-0	Carbon Brush	2
3	806-942306-007-0	Brush Stopper	2
4	806-942306-011-0	Armature	1
5	134-147133-0	Spindle Screw	1
6	134-132341-0	Spindle Assembly	1
7	134-132502-0	Sensor	3
8	134-132344-0	Carriage Assembly	1
9	134-132343-0	Collet Assembly	1
10	134-147144-0	Collet	1
11	134-132362-0	Head Load Assembly (includes 12, 13)	1
12	134-132351-0	Rotary Solenoid	1
13	134-147097-0	Head Load Cam	1
14	134-132355-0	Pop-Up Assembly	1
15	134-147094-0	Guide Rail	1
16	134-132360-0	Sensor Cable Assembly (includes LED Assembly and Index Sensor)	1
17	134-835102-0	G9NYF PCB Assembly	1
18	134-132358-0	Lock Lever Assembly	1
19	134-147119-0	Base Frame	1
20	134-132357-0	Display Lamp Assembly	1
21	134-147098-002-A	Front Panel	1
22	134-147102-002-A	Door Handle	1
23	134-147602-0	Front Panel Screw	2
24	134-147100-0	Lever Plate	1
25	134-147106-0	Handle Plate	1
26	134-132455-0	Hinge Assembly	1
27	134-132498-0	Door Lock Solenoid	1
28	134-147124-0	Cover Plate	1
201	805-010026-004-0	CFIMSx26x4x15BF	4
203	805-010003-006-0	CFIMSx3x6x15BF	2
206	805-300026-004-0	PL-CPIMSx2.6x6x15BF	6
207	805-300003-106-0	PL-CPIMSx3x6x15BF	2
209	805-310026-008-0	SL-CPIMSx2.6x8x15BF	2
210	805-310003-006-0	SL-CPIMSx3x6x15BF	3
212	805-311103-006-0	SL-CPBMSx3x6x15GF	2
213	805-341126-006-0	S-CPIMSx2.6x6x15BF	4
214	805-320003-005-0	P-CPIMSx3x5x15BF	4



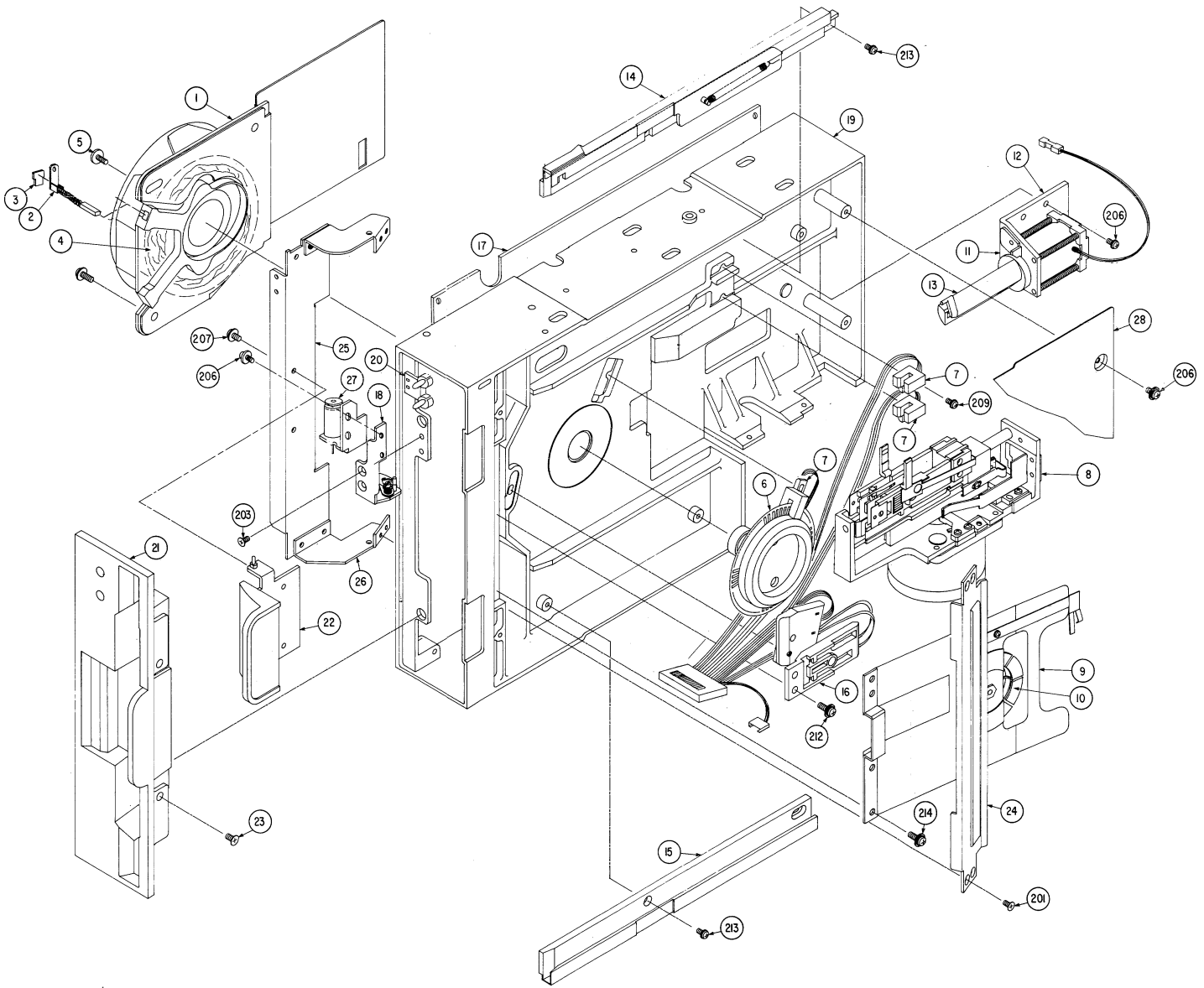
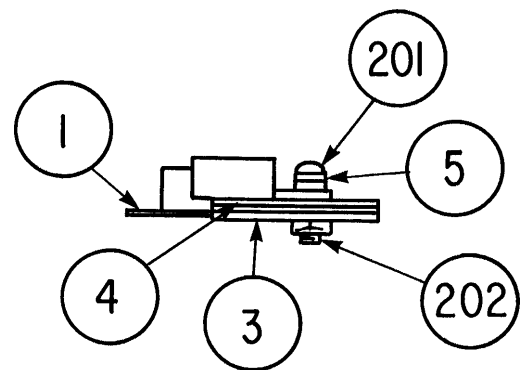
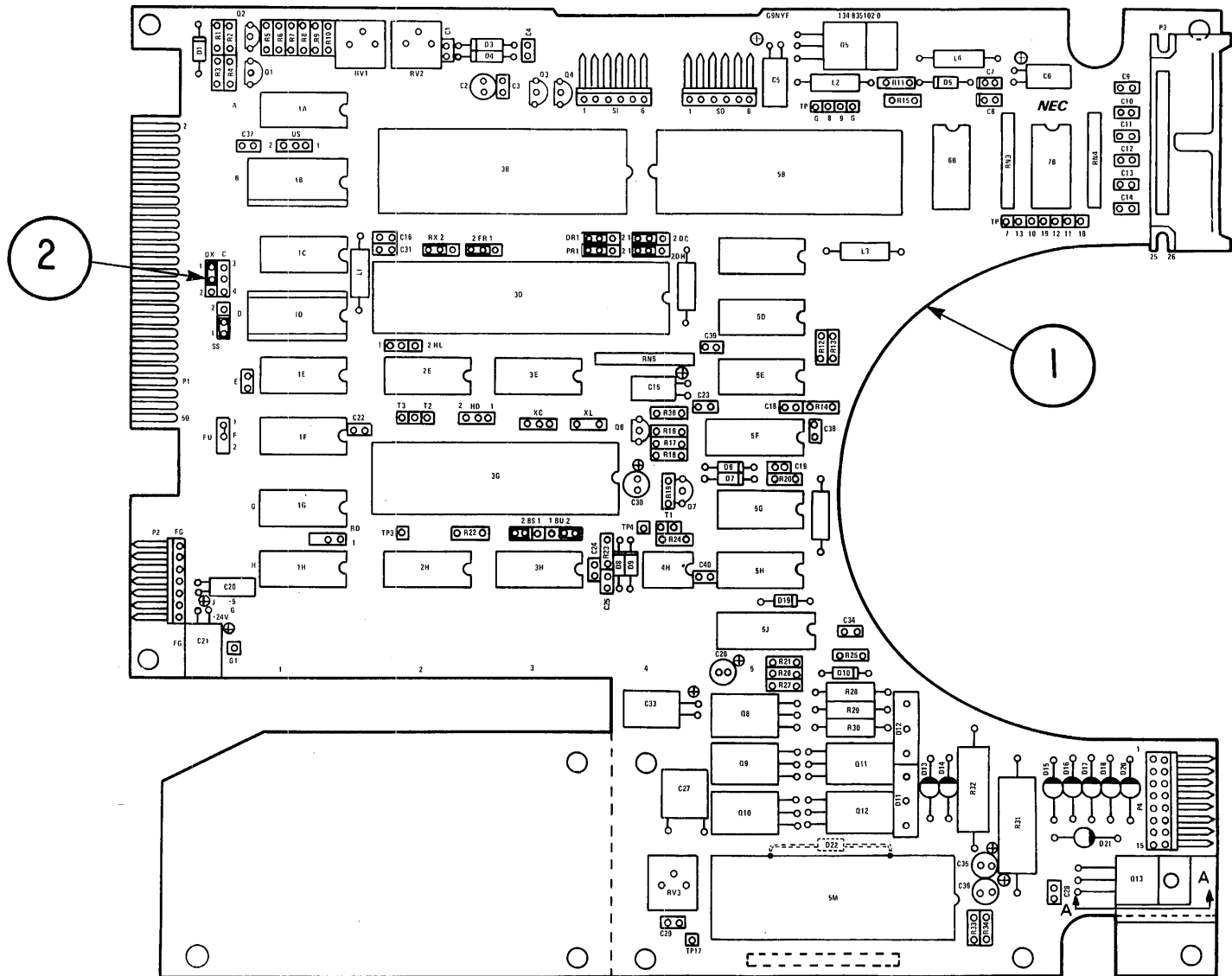

Figure 6-1 FD1165 Flexible Disk Drive

ASSEMBLY OR LOCATION	PART NUMBER	DESCRIPTION	QTY
1A, 1F, 1G	802-110123-002-A	Integrated Circuit SN7438N	1
1B, 1D	802-730014-116-0	16-pin Socket	2
1C, 1H, 7B	802-120110-002-A	Integrated Circuit 74LS14PC	3
1E	802-121076-001-A	Integrated Circuit SN74LS11N	1
2E, 2H, 5H	802-120050-002-A	Integrated Circuit SN74LS04N	3
3B	806-921691-0	Integrated Circuit HMC 105	1
3D	806-921640-001-0	Integrated Circuit #PD52502D	1
3E, 5D	802-120056-002-A	Integrated Circuit 74LS74PC	2
3G	806-921411-005-0	Integrated Circuit #PD8748-E15	1
3H	802-120051-002-A	Integrated Circuit SN74LS08N	1
4H	802-180092-002-0	Integrated Circuit 555 Timer	1
5B	806-921692-0	Integrated Circuit HMC 106	1
5C, 5G	802-110070-002-0	Integrated Circuit SN7406N	2
5E	802-120055-002-A	Integrated Circuit SN74LS51N	1
5F	802-110063-002-0	Integrated Circuit 9602 PC	1
5J	806-921669-001-0	Integrated Circuit SN75468N	1
5M	806-921665-0	Integrated Circuit HMC 93	1
6B	802-180106-002-A	Integrated Circuit #PC 319C	1
C1, C4	802-410047-104-0	Capacitor CCD10CH1H220K	2
C2	802-410046-002-0	Capacitor CN1A220M1S	1
C3, C7-C15	802-410047-406-0	Capacitor CKD10F1H1042	19
C22, C23, C25			
C28, C29, C34, C38-C40			
C5, C6, C20	806-924154-082-0	Capacitor SM50VB-470M	3
C16, C37	802-410047-308-0	Capacitor CKD10C1H632M	2
C18	802-410047-118-0	Capacitor CCD10CH1H331K	1
C19	802-410047-109-0	Capacitor CCD10CH1H560K	1
C21, C33	806-924154-088-0	Capacitor SM50VB-470M	2
C24	802-410047-307-0	Capacitor CKD10C1H472M	1
C26, C36	802-410046-024-0	Capacitor DN1A470M1S	2
C27	806-924151-045-0	Capacitor AMX-683K	1
C30	802-410046-019-0	Capacitor DN1A68M1S	1
C35	802-410046-061-0	Capacitor DN1V100M1S	1
D1	802-230013-016-0	Diode RD3.6EB	1
D3, D4, D8, D9, D10, D19	806-922121-0	Diode 1S953	6
D5	802-230014-041-0	Diode RD18FB	1
D6, D7	806-922318-049-0	Diode RD223B1	2
D11, D12	806-922208-001-0	Diode MI101	2
D13, D14	802-230014-047-0	Diode PD24FB	2
D15-D18, D21	802-210002-0	Diode F14C	5
D22	802-230013-042-0	Diode RD12EB	1
L1, L5	802-530001-037-0	Inductor TP0410L-102J	2
L2, L3	802-530001-034-0	Inductor TP0410L-331J	2
L4	802-530001-015-0	Inductor TP0410L-330K	1
P2	802-710165-207-0	Connector 171826-7	1
P3	806-927164-826-0	Connector 3493	1
P4	806-927325-216-0	Connector 65625-216	1

ASSEMBLY OR LOCATION	PART NUMBER	DESCRIPTION	QTY
Q1, Q2, Q6, Q7	802-250023-0	Transistor 2SC2002	6
Q3, Q4	802-250022-0	Transistor 2SK163	2
Q5	802-180104-001-0	Transistor 78M12	1
Q8	806-922652-0	Transistor 2SB744A	1
Q9, Q11	802-260053-0	Transistor 2SD985	2
Q10, Q12	802-260054-0	Transistor 2SB794	2
Q13	802-260028-0	Transistor 2SD560	1
R1, R4, R12, R13, R19	806-923120-049-0	Resistor 1 K $\Omega$ , 1/4 W, $\pm$ 2%	5
R2	806-923120-060-0	Resistor 3 K $\Omega$ , 1/4 W, $\pm$ 2%	1
R3	806-923120-035-0	Resistor 270 $\Omega$ , 1/4 W, $\pm$ 2%	1
R5, R6	806-923120-071-0	Resistor 3.2 K $\Omega$ , 1/4 W, $\pm$ 2%	2
R7-R10, R15	806-923120-053-0	Resistor 11.5 K $\Omega$ , 1/4 W, $\pm$ 2%	5
R11, R23	806-923120-069-0	Resistor 6.8 K $\Omega$ , 1/4 W, $\pm$ 2%	2
R14	806-923120-072-0	Resistor 9.1 K $\Omega$ , 1/4 W, $\pm$ 2%	1
R16	806-923120-079-0	Resistor 18 K $\Omega$ , 1/4 W, $\pm$ 2%	1
R17	806-923120-085-0	Resistor 33 K $\Omega$ , 1/4 W, $\pm$ 2%	1
R18	806-923120-057-0	Resistor 2.2 K $\Omega$ , 1/4 W, $\pm$ 2%	1
R20, R21, R27	806-923120-067-0	Resistor 5.6 K $\Omega$ , 1/4 W, $\pm$ 2%	1
R22, R25, R36	806-923120-073-0	Resistor 10 K $\Omega$ , 1/4 W, $\pm$ 2%	3
R24	806-923120-064-0	Resistor 4.3 K $\Omega$ , 1/4 W, $\pm$ 2%	1
R26	806-923120-047-0	Resistor 920 $\Omega$ , 1/4 W, $\pm$ 2%	1
R28	806-923109-109-0	Resistor 10 $\Omega$ , 1/2 W, $\pm$ 2%	1
R29, R30	806-923109-165-0	Resistor 2.2 $\Omega$ , 1/2 W, $\pm$ 2%	2
R31	806-923152-166-0	Resistor MSS03N750J	1
R32	806-923152-028-0	Resistor MSS02N2R0J	1
R33, R34	806-923120-033-0	Resistor 220 $\Omega$ , 1/4 W, $\pm$ 2%	2
R35	806-923109-147-0	Resistor 390 $\Omega$ , 1/4 W, $\pm$ 2%	1
RN1, RN2	802-190022-001-0	Resistor Module 6613R150	2
RN3	806-923150-043-0	Resistor Module RDSG7x561J	1
RN4	806-923150-033-0	Resistor Module RDS7x221J	1
RN5	806-923150-073-0	Resistor Module RDSG7x103J	1
RV1, RV2	806-923205-010-0	Trim Pot 72PR10K	2
RV3	806-923205-011-0	Trim Pot 72PR20K	1
SO, SI	806-927324-006-0	Connector FS-6PA-S4LT1-A1	2
SS, BV, BS, HL, PR, FR, RX, DX, DR, DR, DL	806-927214-403-0	Terminal 2-149-3P	12
T(n), TP(n)	803-070040-001-0	Wrapping Post	20
XC	806-924152-001-0	Capacitor Module	1
XL	802-830036-001-0	Crystal	1
(1)	134-855102-0	G9NYF PCB	1
(2)	806-927214-100-0	Jumper 2128	11
(3)	134-147132-0	Heat Sink	1
(4)	134-147132-0	Insulator	1
(5)	806-928810-0	Bushing	1
(201)	805-311103-010-0	SL-CPRMSx3x10x3GF	1
(202)	805-501103-0	AHEXBNx3x3GF	1



View AA

Figure 6-2 G9NYF PCB Assembly



## CHAPTER 7

### SCHEMATIC

This chapter contains the schematic drawings for the G9NYF PCB.



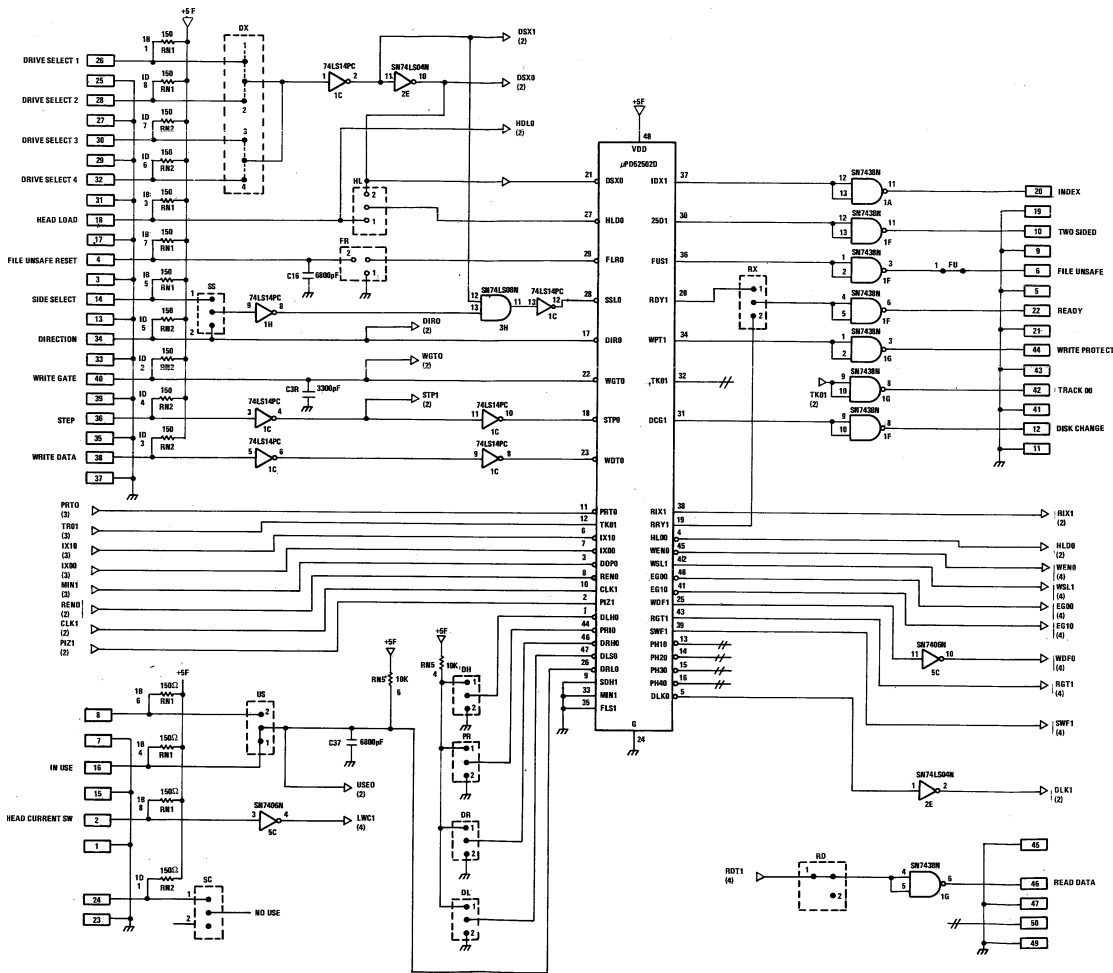

134-110390-501-0  
 FD1165 G9NYF PCB (Sheet 1 of 4)  
 7-3/4

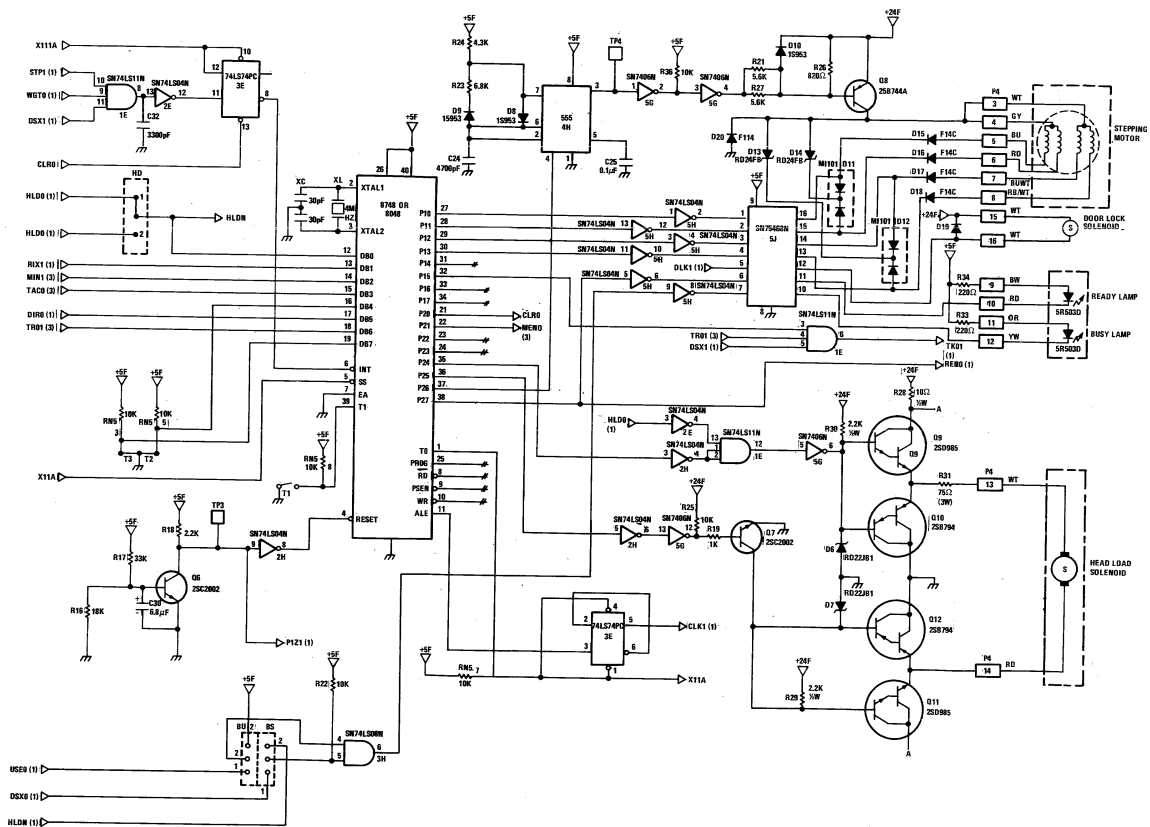

134-110390-501-0  
 FD1165 G9NYF PCB (Sheet 2 of 4)

7-5/6



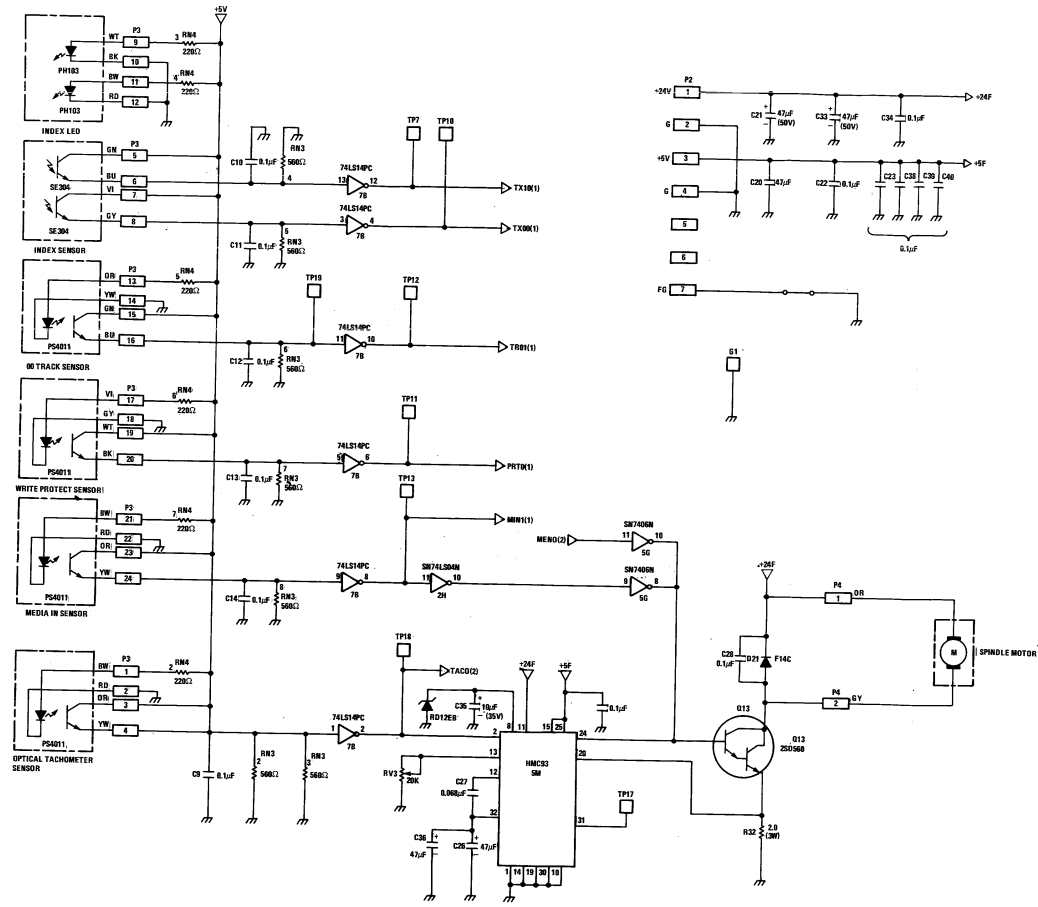

134-110390-501-0  
 FD1165 G9NYF PCB (Sheet 3 of 4)  
 7-7/8

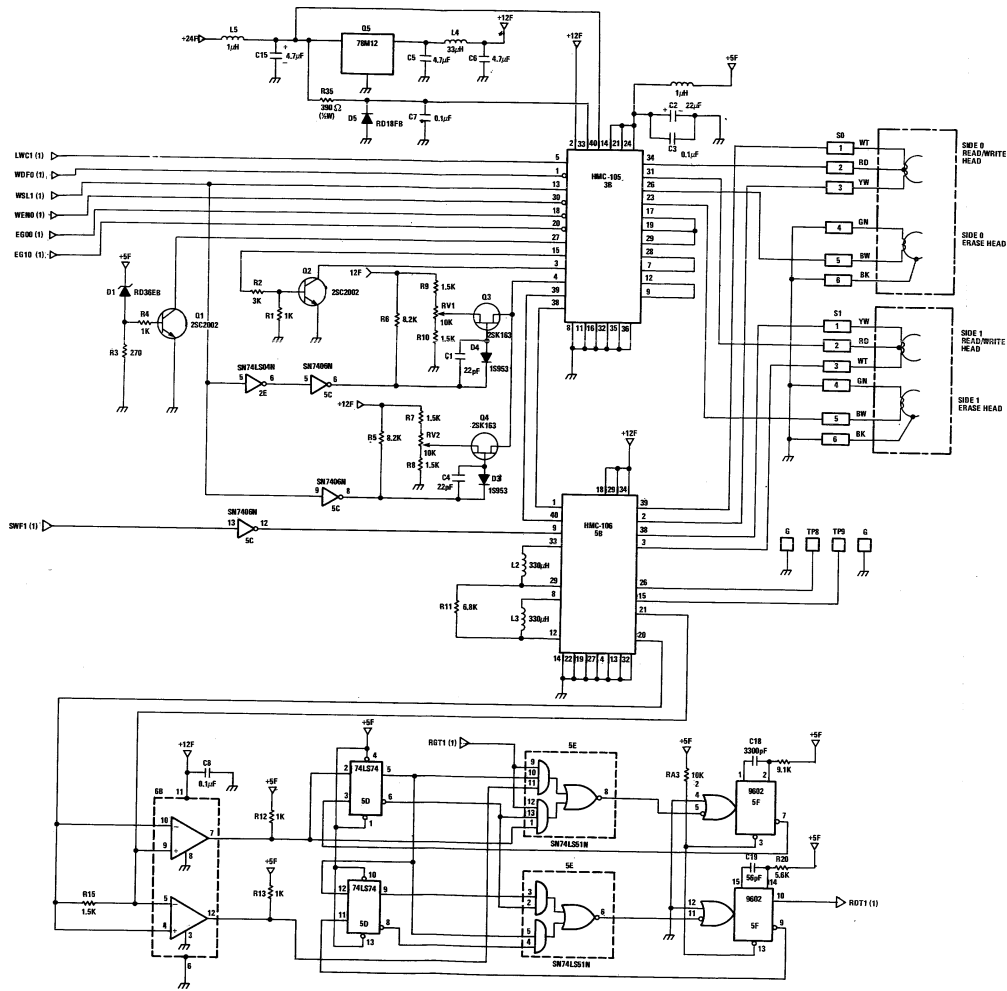

134-110390-501-0  
 FD1165 G9NYF PCB (Sheet 4 of 4)  
 7-9/10

## USER'S COMMENTS FORM

**Document:** FD1165 Flexible Disk Drive Maintenance Manual

**Document No.:** 819-000090-2001

Please suggest improvements to this manual.

---

---

---

---

---

---

---

---

---

---

---

Please list any errors in this manual. Specify by page.

---

---

---

---

---

---

---

---

---

---

---

**From:**

Name \_\_\_\_\_

Title \_\_\_\_\_

Company \_\_\_\_\_

Address \_\_\_\_\_

Date: \_\_\_\_\_

Please cut along this line.

Seal or tape all edges for mailing-do not use staples.

FOLD HERE



NO POSTAGE  
NECESSARY  
IF MAILED  
IN THE  
UNITED STATES

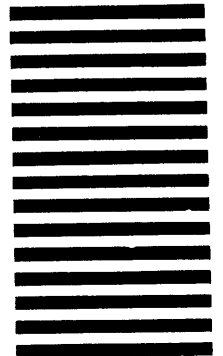

**BUSINESS REPLY CARD**

FIRST CLASS PERMIT NO. 386 LEXINGTON, MA

POSTAGE WILL BE PAID BY ADDRESSEE

**NEC Information Systems, Inc.**  
Dept: Publications  
5 Militia Drive  
Lexington, MA 02173

FOLD HERE

Seal or tape all edges for mailing-do not use staples.