

TJ2-G30048 D

5.25 INCH FLEXIBLE DISK DRIVE

MODEL M4852

MAINTENANCE MANUAL

(STANDARD)

mitsubishi electric co., ltd.

## CONTENT

	PAGE
1. General	1
2. References (Schematic and Manuals)	1
3. Names of Unit Parts	1
4. Operating Information	2
4.1 Environment	2
4.2 Diskette Handling	3
5. Regular Maintenance	4
5.1 Caution	4
5.2 Head Cleaning	5
5.3 Check and Adjustment	6
5.3.1 Diskette rotation cycle adjustment	6
5.3.2 TK 00 sensor position adjustment	8
5.3.3 Index sensor position check	10
5.3.4 Head alignment                    adjustment	11
5.3.5 Head Azimuth check	13

1. General

This manual explains the handling, maintenance and adjustments of M4852 flexible disk unit.

2. References (schematics and manuals)

M4852/4853 Specifications SJ2-3375C

PCA NAMFA schematic diagram for maintenance

TJ2-G4319-A

Illustrated parts list TJ

Packing manual (10 set) -J

3. Names of Unit parts

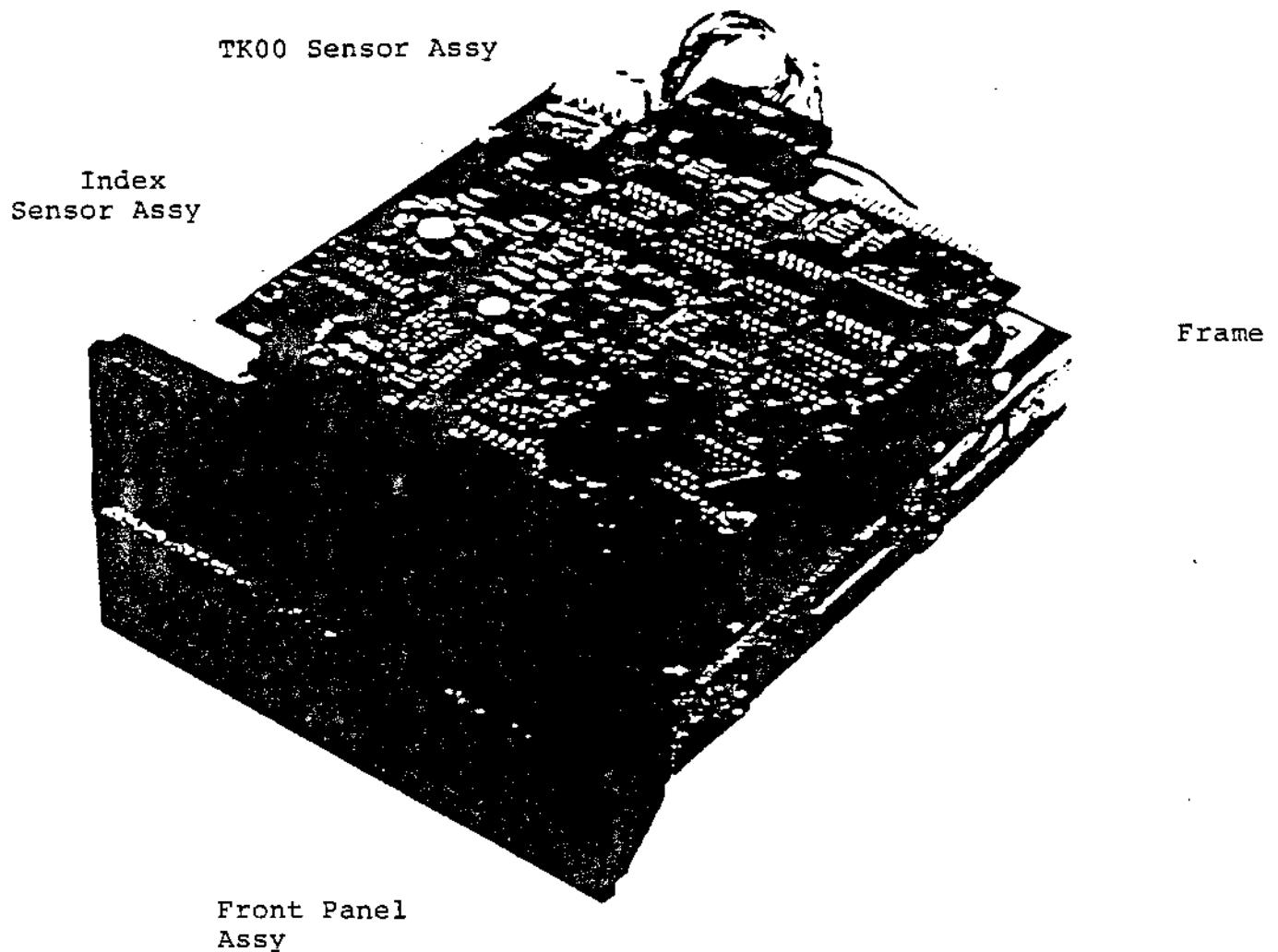

#### 4. Operating Information

##### 4.1 Environment

There is no problem in operating under normal office conditions but when operating out of following conditions, Drive may not work properly or Diskette may get damaged.

##### 1 Temp./Humid. Range

	<u>During operation</u>	<u>During non operation</u>
Temperature Range	5 <sup>0</sup> C - 43 <sup>0</sup> C	-10 <sup>0</sup> C - 50 <sup>0</sup> C
Humidity Range	20% - 80% RH (DEW LESS)	20% - 80% RH (DEW LESS)
	(Maximum wet bulb temp 29.4 <sup>0</sup> C)	

##### 2 Impact shock Vibration

During operation : Less than 0.25G (5 - 100HZ)

During non operation: Continuous vibration  
less than 3.0G (5 - 100HZ)

##### 3 Dust

Be extra careful of dust entering unit because it may cause damage to head or diskette media.

##### 4.2 Diskette Handling (Be extra careful of the following)

- 1 Keep diskette media away from any appliance which may generate magnetic field.  
(ex, Radio, TV, Motor/Dynamo and other electrical appliances)
- 2 Do not bring any ferro magnetic materials near the diskette.
- 3 Do not bend media under any condition.
- 4 Return the diskette to storage envelope when transporting and storing it.
- 5 Do not touch or attempt to clean the disk media surface with alcohol.
- 6 Do not expose diskette to head, dust, or sunlight.
- 7 Do not write anywhere except on the media label and only use a soft felt tip pen.

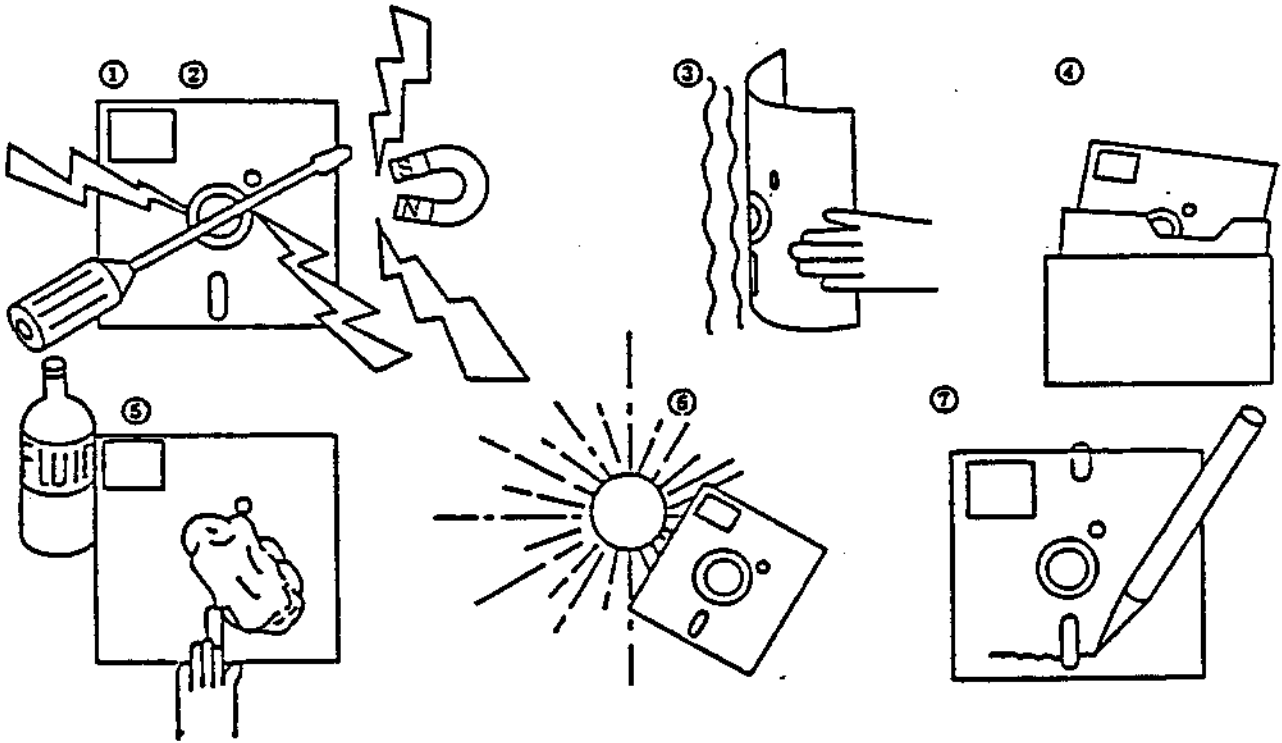

Figure 2

## 5. Regular Maintenance

"Unit life can be affected by damaged parts as a result of dusty environment or excessive operation." So maintenance by such methods as visual inspection, cleaning/change of damaged parts and regular functional checks will keep the unit in good condition and enable the discovery of any problem at an early stage.

Time span between maintenance is calculated at an actual operation rate of 8 hours a day so in case of greater rate, differences modification is needed. When operating at a normal environment condition, perform maintenance once a year.

### 5.1 Caution

- 1 During maintenance, be careful of dust entering unit, and damaging head.
- 2 Make sure power switch is off first, when starting maintenance.
- 3 When put off/on Printed circuit Board (P.C.B.) Assy, make sure power switch is "off" to protect semiconductors and ICs.
- 4 Do not touch Disk media surface or head directly and do not bring any ferro magnetic materials near it.
- 5 When using this unit for Read data only (when using CE Disk), be careful of write mode mishandling to protect data.
- 6 Do not touch steel belt and do not adjust related mechanism.
- 7 Avoid static shock or excessive force to head carriage assembly because it has been carefully adjusted. To not readjust any screws except where specified in this manual.

## 5.2 Head Cleaning on Field Applications

Head cleaning is recommended at user's sites, especially when used in severe environments, because the heads may accumulate dust in the air and magnetic coating material of the disk, causing chance of error increase and/or scratch on the disk surface.

Recommended schedules and procedures are as follows:

### 1) Cleaning Schedules

- (1) Periodical cleaning using wet type cleaning disk.
  - i. Once a month for normal usage in normal environments.
  - ii. Should be increased to about once a week when used in severe environments such as dusty area, high humidity, high and low extreme temperatures. Low temperature such as 5 to 10°C (41 to 50°F) under high humidity is most severe for diskettes.
  - iii. Higher frequency for brand new drives would be recommended, for about once a week. Better matching between head and medium would be produced by a long time use, as experienced.
- (2) When frequent errors are detected. (Wet or dry type may be used.)
- (3) When scratch(es) are found on the medium surface. (Wet or dry type may be used.)

### 2) Recommended Head Cleaning Material

#### (1) Wet type

Innovative Computer Products\*, Head Cleaning Kit (or equivalent).

\*18360 Oxnard Street, Tarzana, California 91356  
(213) 996-4911/TWX 910-493-5964

#### (2) Dry type

To be supplied by Mitsubishi representatives. No substitutions would be allowable unless accepted by factory test.

## 5.3 Check and Adjustments

### 5.3.1 Diskette rotational cycle adjustments

#### 1) Equipment

CE Tester

Scratch Diskette

Universal Counter

VR Adjustment Driver

#### 2) Adjustment procedure

2)-1 Connect CE Tester to Drive then turn-on power switch.

2)-2 Load diskette then turn-on motor with drive select.

2)-3 Make sure HLMG ON.

2)-4 Seek to TK00.

2)-5 Connect universal counter to INDEX (TPB2)  
and measure rotational cycle rate.

2)-6 Adjust counter reading until it comes within  
specifications using SPM VR (see Figure 4).

2)-7 After this adjustment, Lock VR with white paint.

#### 3) Test specification

3)-1 Check:  $\pm 1.6\%$  (196.8 - 203.2ms)

3)-2 Adjust:  $\pm 1.0\%$  (198.0 - 202.0ms)



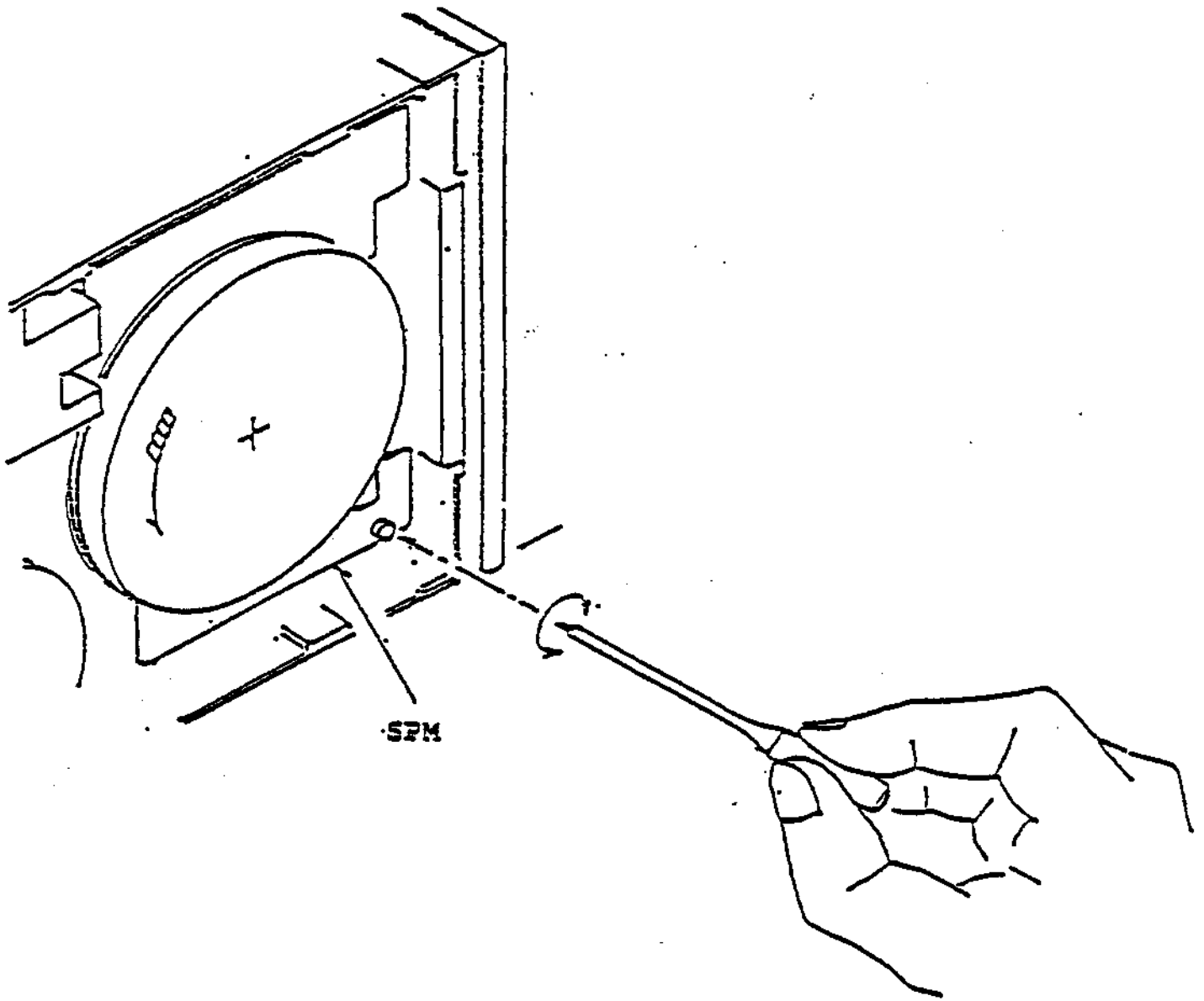

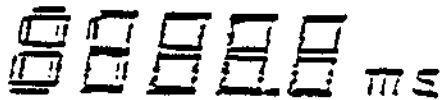
  
 198.0 - 202.0

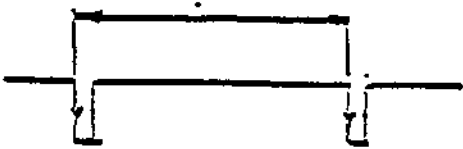

INDEX  
 (TPB2)

FIGURE 4

### 5.3.2 TK00 sensor position adjustment

#### 1) Equipment

CE Tester

Scratch Diskette

No. 1 plus screw driver

Oscilloscope

#### 2) Adjustment procedure

2)-1 Connect CE Tester to Drive then turn-on power switch and load diskette.

2)-2 Turn-on motor and select drive.

2)-3 Repeat seek between TK00 and 02 (see Figure 5).

2)-4 Observe waveform (TK00) at TPB1 using oscilloscope.

trigger	CH1--step (DC, +)	TPB4
signal	CH2--TK00 (DC +)	TPB1

2)-5 Loosen screw and adjust time 7 until it comes to within 3-4ms by moving TK00 in the direction of the arrow (see figure).

#### 3) Note:

3)-1 Set step rate at 3ms using CE tester.

3)-2 Make sure there are 2 pulses on step signals.

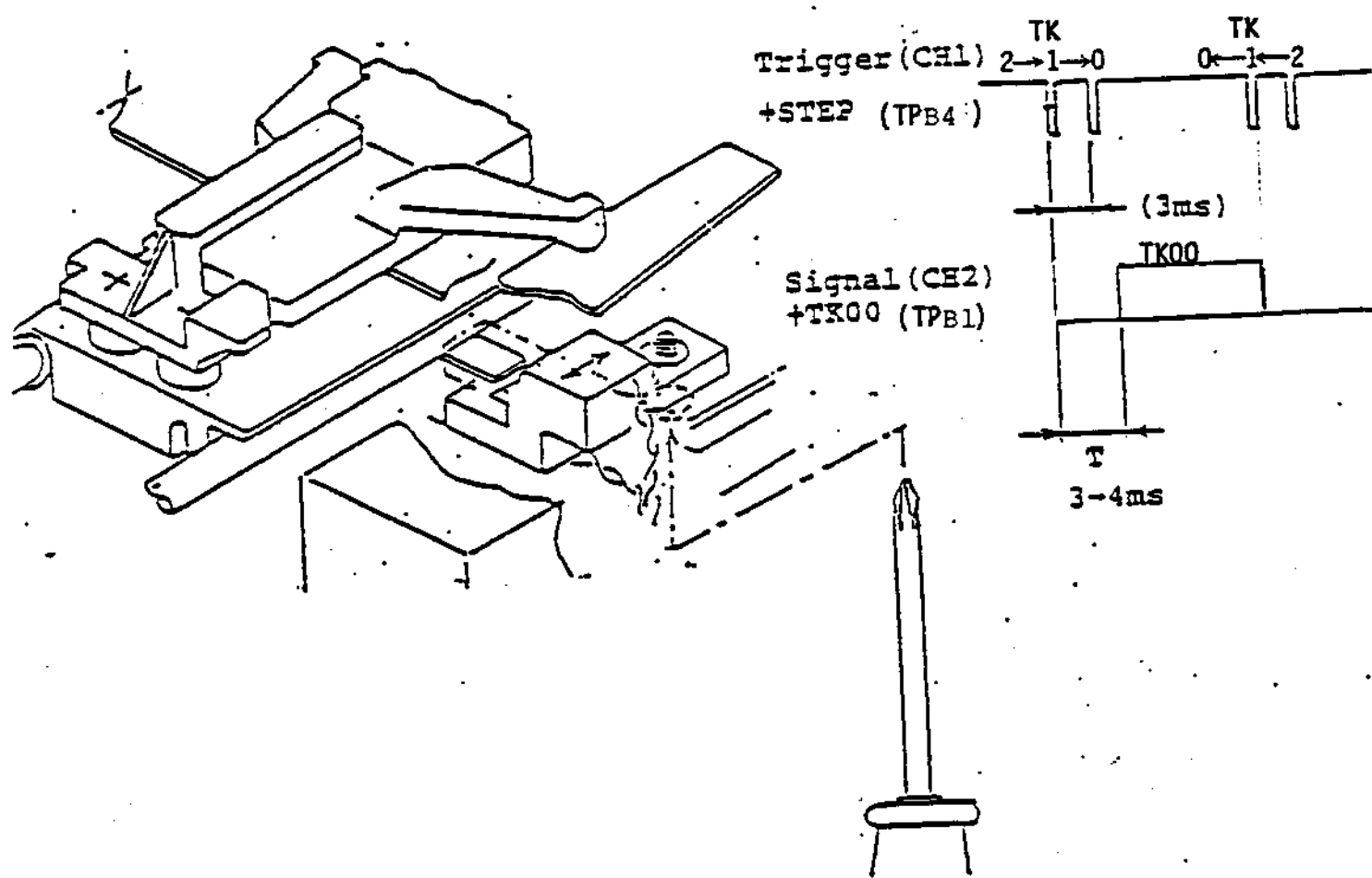

FIGURE 5

### 5.3.3 INDEX sensor position adjustment

#### 1) Equipment

CE Tester

CE diskette (DYMEK 502-1D CE DISKETTE)

No. 1 plus screw driver

Oscilloscope

#### 2) Check procedure

2)-1 Connect CE Tester to Drive (set power off).

2)-2 Turn-on power switch and motor on.

2)-3 Select drive and load CE diskette (close clamp door slowly).

2)-4 Read timing of each waveform at TPB9. TPB10 under read mode TK02, using oscilloscope. (See figure.)

Trigger: EXT - -INDEX (DC, +) (TPB2.)

Signal: CH1 - TPA9 (AC ) Add  
CH2 - TPA10 (AC,INV)

#### 2)-5 Specification

Check:  $200 \pm 200 \mu s$  at TK02 (Side 0)

$200 \pm 300 \mu s$  at TK02 (Side 1)

Adjust:  $200 \pm 100 \mu s$  at TK02 (Side 0)

$200 \pm 200 \mu s$  at TK02 (Side 1)

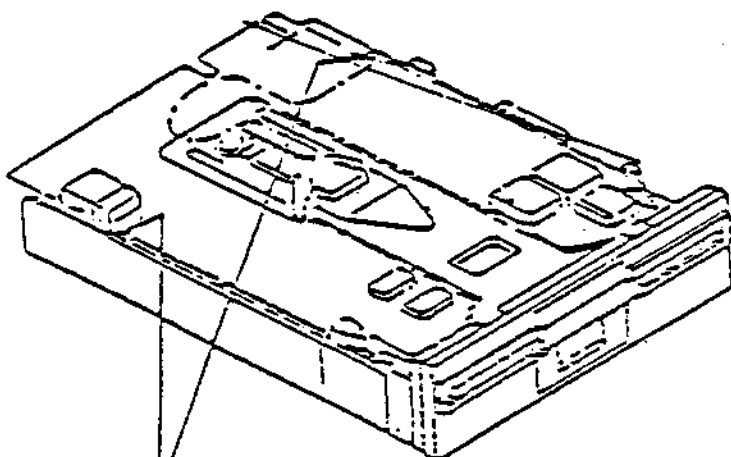

PCA set screw

Trigger  
+INDEX  
(TPB2)

Signal  
TPA9-10  
(Burst  
waveform)

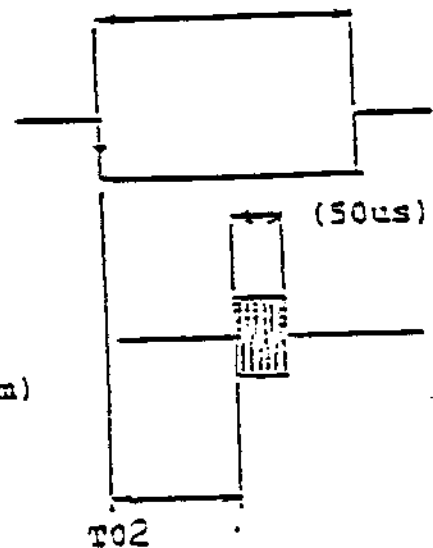

FIGURE 6

### 5.3.4 Head alignment adjustment

1) Equipment

CE Tester

CE Diskette (DYMEK 502-1D CE DISKETTE)

No. 1 screw driver

Oscilloscope

Hex wrench (1.5mm dia.)

(Fine point diagonal cutter)

2) Adjustment procedure

2)-1 Connect CE Tester to Drive (set power off).

2)-2 Turn-on power switch and motor on.

2)-3 Select drive and load CE diskette (close clamp door slowly).

2)-4 Seek TK00 to TK32 then read amplitude of each waveform (positioning waveform) at TP89, TP10 under read mode (see Figure 7).

Trigger: EXT - -INDEX (DC, +) (TPB2)

Signal: CH1 - TPA9 (AC )  
CH2 - TPA10 (AC,INV) Add

Specification:	CHECK	ADJUST
when A>B	B/A > 0.57	0.6
A<B	A/B > 0.57	0.6

2)-6 In case seek direction is TK00 TK32 or TK79 TK32, loosen both set screws, then adjust STM until signal comes within spec. Tighten screw.

3) Note: Adjust under following conditions

Temperature: 23°C ±2°C exposed over 2 hours  
Humidity: 50% ±5%

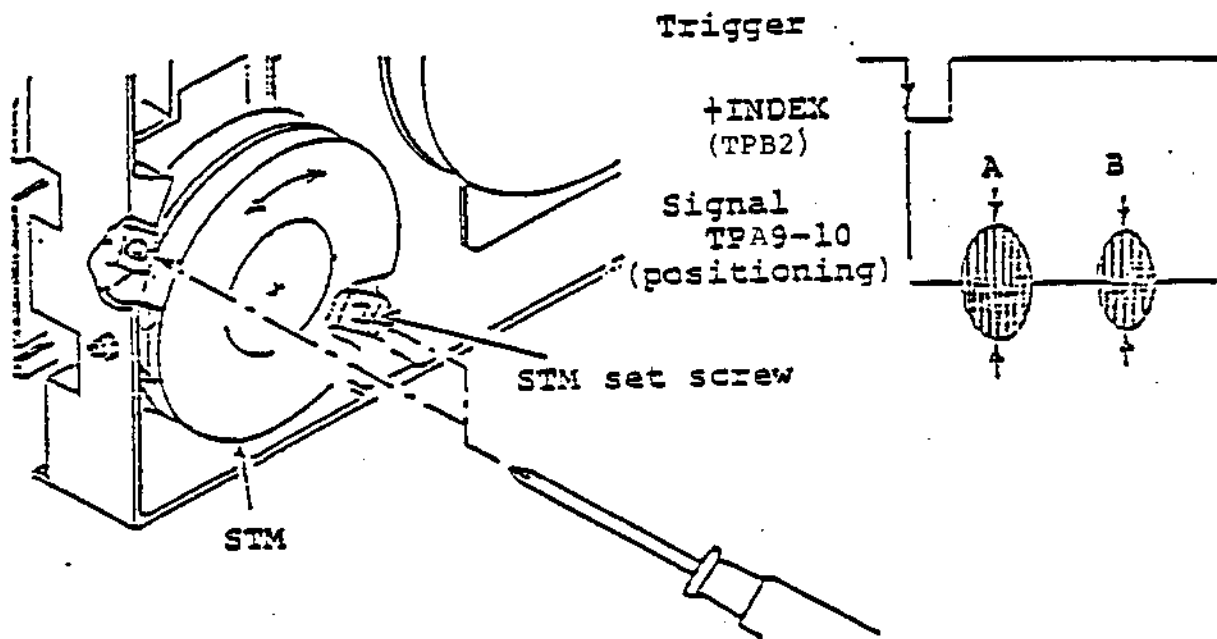

FIGURE 7

### 5.3.5 Head Azimuth

1) Equipment

CE Tester  
 CE Diskette  
 Oscilloscope

2) Check procedure

- 2)-1 Connect CE Tester to Drive then turn-on power switch.
- 2)-2 Turn on motor.
- 2)-3 Select drive and load CE diskette.
- 2)-4 Seek to TK68.
- 2)-5 Read azimuth waveform using oscilloscope.

Trigger: EXT - -INDEX (DC +) (TPB2)

Signal: CH1 - TPA9 (AC )  
 CH2 - TPA10 (AC,INV) Add

- 2)-6 Acceptable when adjusted waveform within following range

FIGURE 8

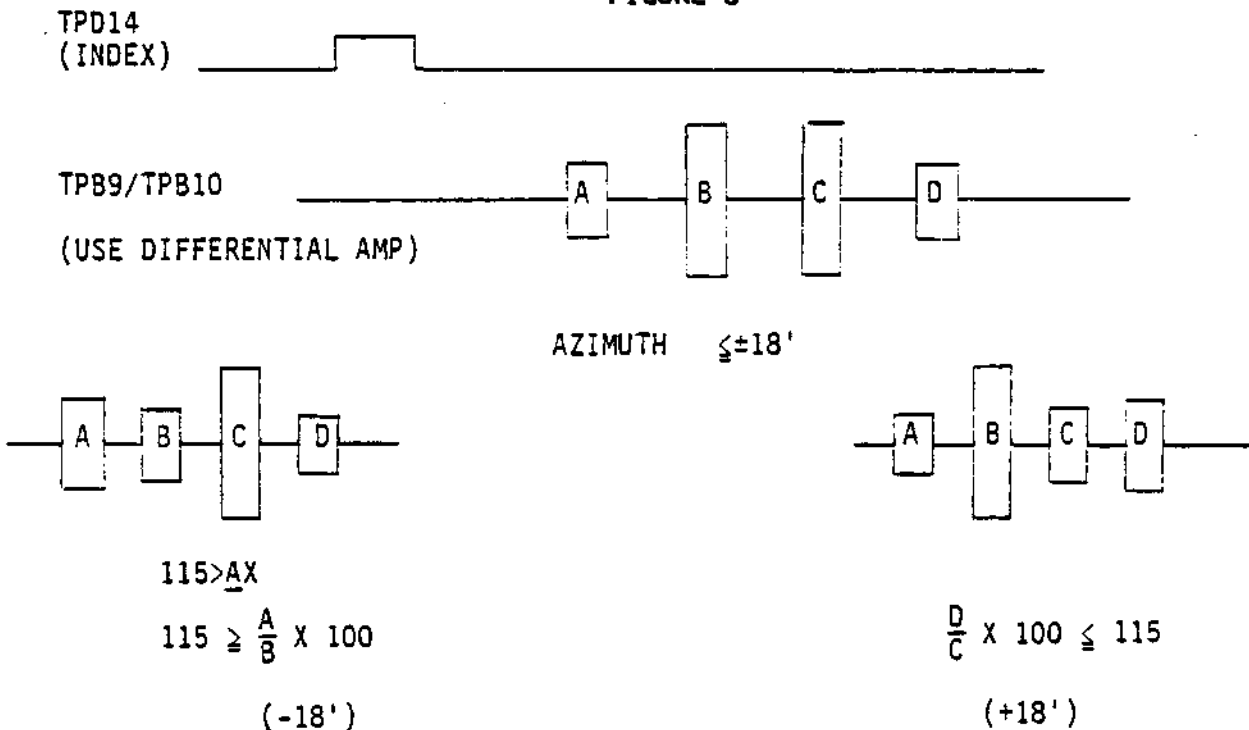

Note: A=B: -12min  
 C=D: +12min

Specification=  $\pm 18$ min

NOTE

The head's azimuth is not adjustable. It is suggested that the drive be sent to an authorized repair center or a new head assembly be installed. In the latter case, all previous adjustments should be made again.