

PRODUCT SPECIFICATION
FOR
FLEXIBLE DISK DRIVE
MODEL 9409

		PC	SPEC. NO.	SHEET	REV.
		A	77653379	2	A

PRODUCT SPECIFICATION FOR THE 9409 FDD

TABLE OF CONTENTS

1.0	GENERAL DESCRIPTION	4
2.0	APPLICABLE DOCUMENTS	5
	2.1 STANDARDS.....	5
	2.2 DOCUMENTS.....	6
3.0	FEATURES	6
	3.1 STANDARD FEATURES	6
	3.2 ACCESSORIES/SPECIAL TOOLS	6
4.0	PERFORMANCE SPECIFICATIONS	7
	4.1 DEFINITIONS.....	7
	4.1.1 Latency	7
	4.1.2 Seek/Settle Time	7
	4.1.3 Head-Load Time	8
	4.1.4 Read Stabilization	8
5.0	FUNCTIONAL SEPCIFICATIONS	8
6.0	RELIABILITY SPECIFICATIONS	8
7.0	PHYSICAL/ELECTRICAL SPECIFICATION.....	9
	7.1 POWER REQUIREMENTS	9
	7.2 POWER DISSIPATION	10
	7.3 INRUSH CURRENT	10
	7.4 ENVIRONMENTAL LIMITS	11
	7.5 MECHANICAL SPECIFICATIONS	11
	7.5.1 Drive Orientation	13
8.0	RECORDING CHARACTERISTICS/FORMAT	13
	8.1 ENCODING METHODS	13
	8.1.1 Single-Density Recording	13
	8.1.2 Double-Density Recording	13
	8.1.2.1 Write Precompensation	14
	8.2 FORMAT CONSIDERATIONS	15
	8.2.1 Index Tolerance	15
	8.2.1.1 Post Index	15
	8.2.1.2 Pre-Index	15
	8.2.2 Inter-Record Tolerance	16
	8.2.2.1 Pre-Address	16
	8.2.2.2 Pre-Data	16
	8.2.3 Soft-Sector Formatting	16
	8.2.4 Hard-Sector Formatting	16

		PC	SPEC. NO.	SHEET	REV.
		A	77653379	3	A

PRODUCT SPECIFICATION FOR THE 9409 FDD

9.0	INSTALLATION INFORMATION	20
9.1	ELECTRICAL INTERFACE	20
9.2	POWER CONNECTOR	20
9.3	I/O CONNECTOR	23
9.4	GROUNDING REQUIREMENTS	24
9.5	CONFIGURATIONS	24
	9.5.1 Daisy-Chain Configuration	24
	9.5.2 Radial Configuration	26
9.6	INTERFACE TERMINATIONS	26
	9.6.1 Areas of Termination	27
	9.6.2 Termination of Radial Configuration	27
	9.6.3 Termination in a Daisy-Chain Configuration	27
	9.6.4 External Terminations.....	27
10.0	ERROR RECOVERY	27
11.0	INTERFACE SIGNAL DESCRIPTION	28
11.1	ACTIVE/INACTIVE LOGIC SIGNALS	28
11.2	INPUT SIGNALS	28
	11.2.1 Drive Select	28
	11.2.2 Motor On	28
	11.2.3 Direction Select	30
	11.2.4 Step	30
	11.2.5 Write Gate	31
	11.2.6 Write Data	32
	11.2.7 Read/Write Operations	33
	11.2.8 Track 00	35
	11.2.9 Index/Sector	35
	11.2.10 Read Data	36
	11.2.11 Write Protect	36
	11.2.12 Side Select	37
	11.2.13 In Use	37
12.0	CUSTOMER SELECTABLE OPTIONS.....	37
12.1	MULTIPLEX OPTIONS	37
12.2	DRIVE SELECT OPTIONS (1, 2, 3, 4)	38
12.3	HEAD LOAD WITH MOTOR ON	39
12.4	HEAD LOAD WITH DRIVE SELECT	39

		PC	SPEC. NO.	SHEET	REV
		A	77653379	4	A

PRODUCT SPECIFICATION FOR THE 9409 FDD

1.0 GENERAL DESCRIPTION

This specification describes the Model 9409 Flexible Disk Drive (FDD). The 5.25-inch FDD features simplicity of design and high reliability at low cost. Device applications include small computer systems, intelligent data terminals, and home computers. Refer to Figures 1 and 2.

The 9409 is a compact, random-access disk drive utilizing standard double-sided 5.25-inch flexible diskette media in either single density (FM) or double density (MFM) recording.

The 9409 contains a drive mechanism to rotate the media, a track accessing positioner, read/write control, and interface circuitry. The interface signal level, power requirements, physical size, and mechanical mounting are compatible with standard industrial requirements. Media interchange is achieved with standard diskette formats which accommodate tunnel erase head structures.

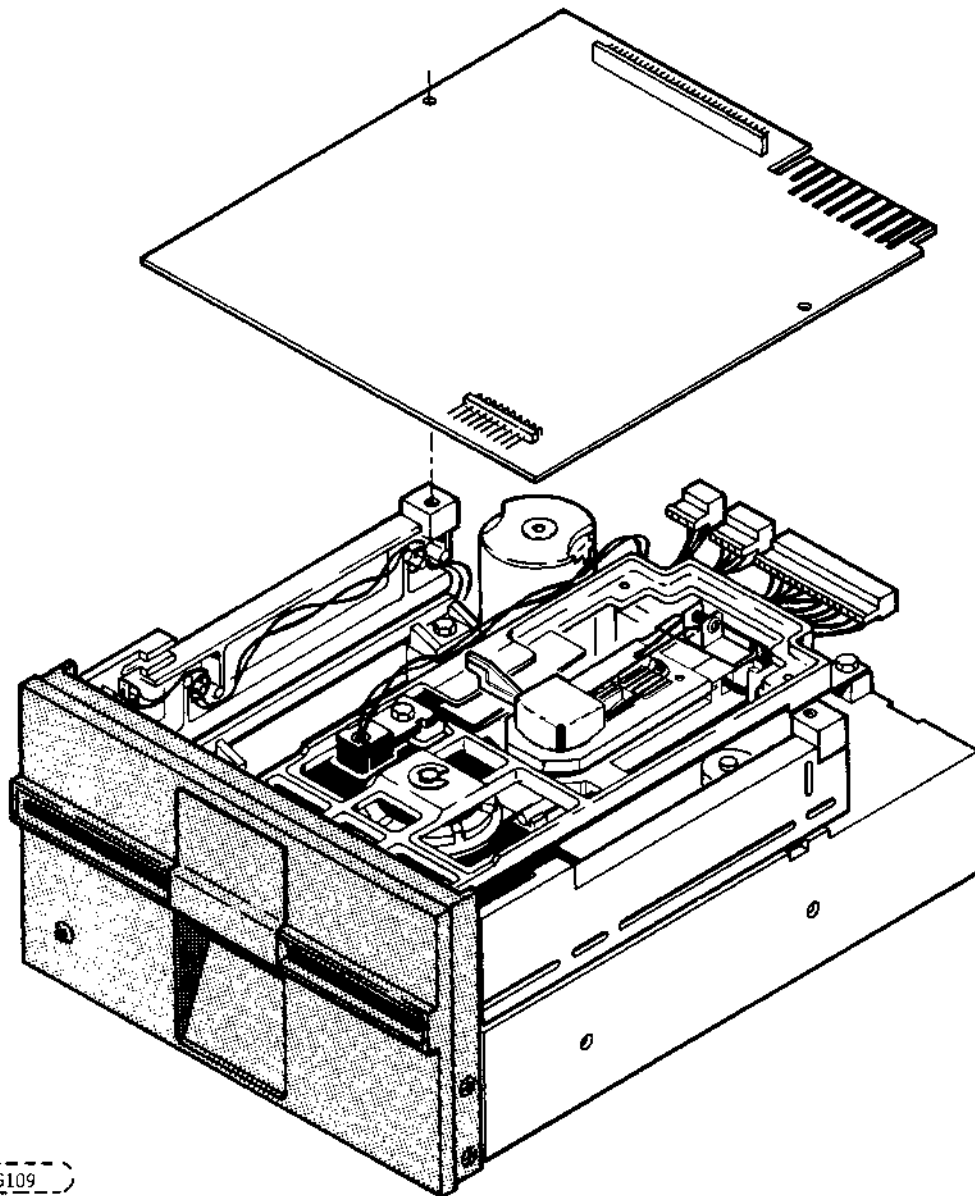

G109

Figure 1. 9409 Flexible Disk Drive

		PC	SPEC. NO.	SHEET	REV.
		A	77653379	5	A

PRODUCT SPECIFICATION FOR THE 9409 FDD

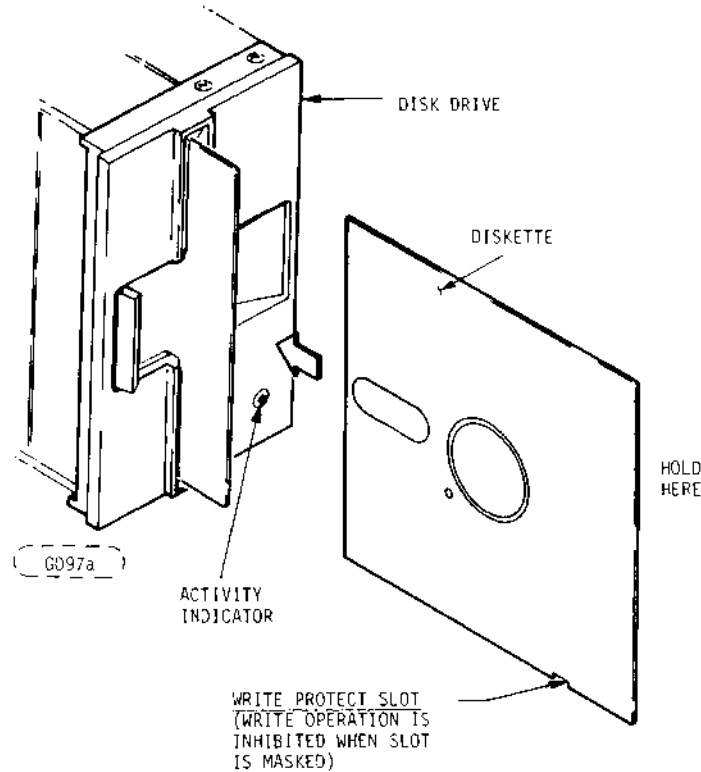

Figure 2. Diskette Insertion

1.0 -contd.

Index pulses are produced by a photoelectric sensing assembly mounted within the 9409. Track-to-track accessing and positioning are accomplished with a DC-powered, +12-volt band stepper motor.

2.0 APPLICABLE DOCUMENTS

2.1 STANDARDS

The Model 9409 FDD has been designed as a system peripheral to the best standards of design and construction. The drive, however, must depend upon its host equipment to receive adequate power and environment in order to provide optimum performance and compliance with applicable industry and governmental regulations. Special attention must be given in the areas of safety, power distribution, grounding, shielding, audible noise control, and temperature regulation of the device to ensure specified performance and compliance with all applicable regulations.

		PC	SPEC. NO.	SHEET	REV.
		6	77653379	6	A

PRODUCT SPECIFICATION FOR THE 9409 FDD

2.1 -contd.

The 9409 is a component and is not subject to standards imposed by FCC Docket 20780/FCC 80-148 Part 15 governing EMI of computing devices.

2.2 DOCUMENTATION

The following documents and specifications provide detailed theory of operation, maintenance procedures, and media format considerations. These documents are not included with each unit, but must be ordered separately.

- Model 9409 FDD Hardware Maintenance Manual, 77653408-3
- Alignment Diskette Specification (Double-Sided Operation), 76209000
- Double-Sided Diskette Specification (5.25-Inch Double Density), 76205900
- Application Note, PLO and Write Precompensation for 5.25-Inch Flexible Disk Drives, 77653447-1
- Application Note, 5.25-Inch FDD Format Considerations and Controller Compatibilities, 75897469

3.0 FEATURES

3.1 STANDARD FEATURES

The 9409 FDD has the following standard features:

- Double-Sided 5.25-Inch Media Capability
- Single-Density (FM) and Double-Density (MFM) Encoding
- Industry-Compatible Interface
- Industry-Compatible Mounting Configurations
- Only Two DC Power Voltages Required (+5 V and +12 V)
- Write Protect Indication
- Activity Indicator
- Long-Life Ceramic Read/Write Heads
- Band Stepper Motor
- Hard or Soft Sector Formatting
- Head Select
- Drive Select
- Track-Zero Detection
- Index Detection
- Step/Direction Control for Track-to-Track Access
- Black Finish

3.2 ACCESSORIES/SPECIAL TOOLS

The following accessories and special tools are recommended:

- Alignment Diskette, CDC Model 445-51
- DIP Switch, AMP 435626-4
- Cutting Tool, AMP 1-435830-4
- Shunt Module, AMP 435704-6
- Connector Kit, 75887774-0

		PC	SPEC NO	SHEET	REV
		A	77653379	7	A

PRODUCT SPECIFICATION FOR THE 9409 FDD

4.0 PERFORMANCE SPECIFICATIONS

	<u>Single Density</u>	<u>Double Density</u>
Capacity		
Unformatted		
Per Disk	250.0 kbytes	500.0 kbytes
Per Surface	125.0 kbytes	250.0 kbytes
Per Track	3.125 kbytes	6.250 kbytes
Formatted (16 Sectors, 128/256 Bytes)*		
Per Disk	163.84 kbytes	327.68 kbytes
Per Surface	81.92 kbytes	163.84 kbytes
Per Track	2048 bytes	4096 bytes
Code	FM	MFM
Transfer Rate	125 kbits/s	250 kbits/s
Latency (Average)	100 ms	100 ms
Seek Time		
Track-to-Track	5 ms	5 ms
Average	80 ms	80 ms
Settle Time	15 ms	15 ms
Head-Load Time	50 ms	50 ms
Side-Select Time	200 μ s**	200 μ s**
Write Precompensation	0	250 ns (trk 0-39)

4.1 DEFINITIONS

4.1.1 Latency

Latency is the time required for the read/write head to reach a particular area on a track after positioning is completed. For a rotational/spindle speed of 300 r/min +3.7%, -3.5%, the 9409 has an average latency of 100 ms.

4.1.2 Seek/Settle Time

The seek/settle time is the time required by the read/write head to move from track to track plus the time needed for the head to stabilize on track prior to data transfer. Seek/settle time for the 9409 is 20 milliseconds: 5 milliseconds for a single track access and 15 milliseconds for head settling time.

* Assumes tunnel erase heads.

** Assumes motor on, drive selected, head loaded, and erase turn-off delay completed from any previous write operation.

		PC	SPEC. NO.	SHEET	REV
		A	77653379	8	A

PRODUCT SPECIFICATION FOR THE 9409 FDD

4.1.3 Head-Load Time

Head-load time is defined as the time from initial activation of the head-load function until valid data transfer between the drive and controller can be assured. The amount of head-load time required by the 9409 is 50 milliseconds. If the unit is configured with head loaded and motor on, valid read data occurs 2 microseconds after drive select.

4.1.4 Read Stabilization

Upon conclusion of a write operation, a minimum delay time of 1 millisecond is required before valid read data can be assured. This time is necessary to allow for the read circuit to stabilize after switching.

5.0 FUNCTIONAL SPECIFICATIONS

	<u>Single Density</u>	<u>Double Density</u>
Encoding Method	FM	MFM
Rotational Speed	300 r/min	300 r/min
Recording Density (Track 39, Side 1)	2938 bpi	5876 bpi
Flux Reversal Density (Track 39, Side 1)	5876 FRI	5876 FRI
Track Density	48 TPI	48 TPI
Tracks per Surface	40	40
Heads	2	2
Inside Recorded Radius (Side 0)	1.437 in (36.49 mm)	1.437 in (36.49 mm)
Outside Recorded Radius (Side 0)	2.250 in (57.15 mm)	2.250 in (57.15 mm)
Inside Recorded Radius (Side 1)	1.354 in (34.39 mm)	1.354 in (34.39 mm)
Outside Recorded Radius (Side 1)	2.167 in (55.04 mm)	2.167 in (34.39 mm)
Motor Start Time	0.5 second	0.5 second
Media	CDC Model 445 or equivalent	CDC Model 445 or equivalent

		PC	SPEC NO	SHEET	REV
		A	77653379	9	A

PRODUCT SPECIFICATION FOR THE 9409 FDD

6.0 RELIABILITY SPECIFICATIONS

The following reliability specifications assume correct host/drive operational interface has been implemented, including all interface timings, power supply voltages, environmental conditions, use of recommended media (or equivalent), and application of recommended data-recovery techniques. (PLO and Write Precompensation Application Note is available on request.) The following MTBF assumes spindle drive motor duty cycle is 25% of power-on hours.

Error Rates

Soft Read Errors	1 per 10 ⁹ bits read
Hard Read Errors	1 per 10 ¹² bits read
Seek Errors	1 per 10 ⁶ seeks

MTBF 8000 Power-On Hours, Typical Usage

MTTR 0.5 Hour

Service Life 5 years

Media Life

Wear Revolutions	Greater than 3 X 10 ⁶
Insertions	Greater than 30,000

Preventive Maintenance None Required

7.0 PHYSICAL/ELECTRICAL SPECIFICATIONS

7.1 POWER REQUIREMENTS

There are no AC power requirements for the 9409. DC power requirements are as shown in Table 1.

Table 1. DC Power Requirements

CONDITIONS	NOMINAL VOLTAGE	
	+5 V	+12 V
Tolerance	±0.25 V	±0.6 V
Ripple (Peak to Peak)	≤50 mV	≤100 mV
Seeking Current:		
Typical	0.5 A	0.9 A
Maximum	*0.7 A	*1.8 A

*Specified current requirements are on a per-drive basis. Current requirement increases by a factor equal to the number of drives per power supply. (For example, two drives per supply would require +12 V at 3.6 A and +5 V at 1.4 A.)

PRODUCT SPECIFICATION FOR THE 9409 FDD

7.2 POWER DISSIPATION

26.4 watts (maximum)
 13.3 watts (nominal)

7.3 INRUSH CURRENT

Inrush current is dependent upon the power source as well as the 9409. Primary considerations are host power supply source impedance(s), host-to-9409 power line resistance and inductance, and 9409 capacitance load presented by the filter capacitors. Schematically, this may be represented as shown in Figure 3.

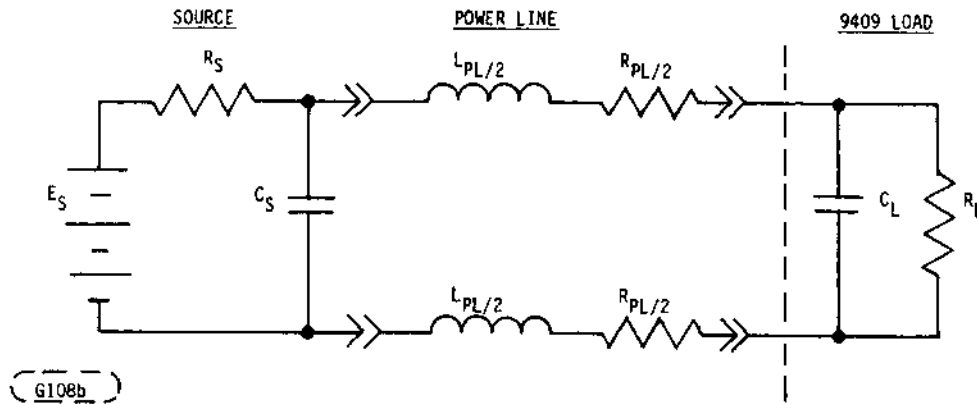

Figure 3. Inrush Current

Nominal equivalent loads for the 9409 are as follows:

	<u>+12 V</u>	<u>+5 V</u>
C_L	22 microfarads	11.8 microfarads
R_L	13 ohms	10 ohms

		PC	SPEC. NO.	SHEET	REV.
		A	77653379	11	A

PRODUCT SPECIFICATION FOR THE 9409 FDD

7.4 ENVIRONMENTAL LIMITS

Temperature and humidity specifications preclude condensation on any drive part. The 9409 is intended for use with host systems which operate in computer room and office environments. Altitude and barometric pressure specifications are referenced to a standard day at 58.7°F (14.8°C).

	<u>Operating</u>	<u>Shipping & Storage</u>
Ambient Temperature	*40° to 115°F *(4.4° to 46.1°C)	-40° to 144°F (-40° to 62.2°C)
Temperature Gradient	18°F/hr (-7.7°C/hr)	36°F/hr (20°C/hr)
Relative Humidity	20% to 80%	0 to 95%
Maximum Wet Bulb Temperature	79°F (26.1°C)	No condensation
Altitude (Sea Level Reference)	-983 to +9850 feet (-300 to +3002 meters)	-983 to +9850 feet (-300 to +3002 meters)
Barometric Pressure		
in. of HG	30.9 to 22.2	30.9 to 18.8
mm of HG	784.9 to 563.6	784.9 to 476.9
psi	15.18 to 10.9	15.18 to 9.22

7.5 MECHANICAL SPECIFICATIONS

Following are mechanical specifications for the 9409. Refer to Figure 4 for detailed mounting dimensions.

Height:	3.38 inches	85.8 mm
Width:	5.88 inches	149.4 mm
Depth:	8.29 inches	210.6 mm
Weight:	3.2 pounds	1.45 kg

*Actual operating temperature is limited by media environmental specifications and performance. See applicable media specifications.

		PC	SPEC. NO	SHEET	REV.
		A	77653379	12	A

PRODUCT SPECIFICATION FOR THE 9409 FDD

WT: 3.2 lbs. (1.45 kg)

MOUNTING HOLES: FOUR ON BOTTOM, TWO EACH SIDE; #6-32 X 0.31 in. (7.9 mm) DEPTH

	PACKAGE DIMENSION	
	INCHES	MILLIMETERS
A	8.00 MAX	203.2 MAX
B	5.75 +0.00 -0.02	146 +0.00 -0.5
C	0.29 ±0.02	7.4 ±0.5
D	1.87 ±0.02	47.5 ±0.5
E	3.12 ±0.02	79.2 ±0.5
F	5.88 ±0.01	149.4 ±0.3
G	3.38 ±0.01	85.9 ±0.3
H	0.06 ±0.01	1.5 ±0.3
I	5.50 ±0.02	140 ±0.5
J	0.86 ±0.02	21.8 ±0.5
K	1.50 ±0.01	38.1 ±0.5
L	1.41 ±0.01	35.8 ±0.5

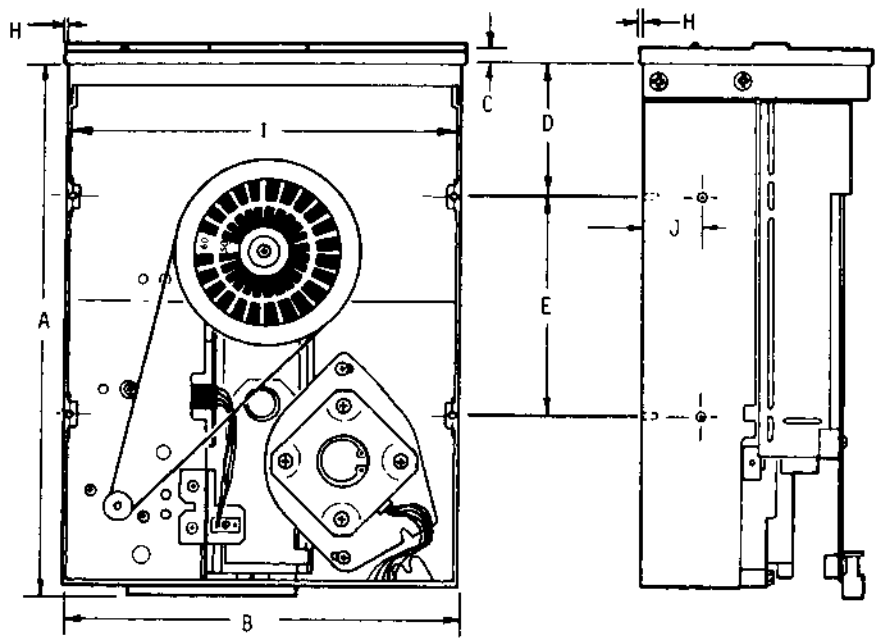
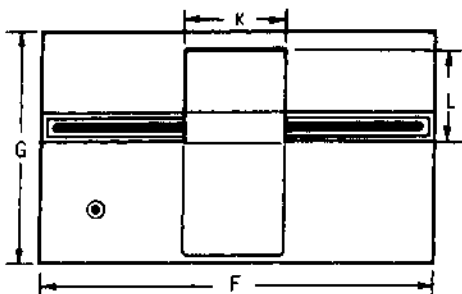

G197a

Figure 4. Dimensions of 9409 FDD

		PC	SPEC. NO	SHEET	REV.
		A	77653379	13	A

PRODUCT SPECIFICATION FOR THE 9409 FDD

7.5.1 Drive Orientation

The 9409 can be mounted in any of the following loading positions:

- horizontal with the access door opening upward and PCB facing upward
- vertical with the access door opening to the left or right
- upright with the front panel at the top.

The drive should not be mounted with the PCB facing downward.

8.0 RECORDING CHARACTERISTICS/FORMAT

Capacity is determined by customer selected data format and coding techniques.

8.1 ENCODING METHODS

Data can be recorded in either FM or MFM encoding. The format of the data recorded is a function of the host system.

8.1.1 Single-Density Recording (Figure 5)

Double-frequency modulation (FM) recording is recommended for use in the single-density mode. FM recording is self-clocking and provides synchronization for data separation utilizing simple one-shot techniques. However, use of a phase-lock oscillator (PLO)* instead of a simple one-shot system will increase operating margins and result in greater data reliability with more tolerance for media imperfections.

8.1.2 Double-Density Recording (Figure 5)

Modified frequency modulation (MFM) recording doubles the drive's capacity. Since the MFM coding technique is not self-clocking, it is necessary to use a PLO* to generate a synchronized clock from the data stream. If both single- and double-density systems are being used, the same PLO serves both applications. Use of MFM recording requires the use of precompensation during writing in order to limit the effective peak shift in the read-back signal.

*PLO and Write Precompensation Application Note is available on request.

		PC	SPEC. NO.	SHEET	REV.
		A	77653379	14	A

PRODUCT SPECIFICATION FOR THE 9409 FDD

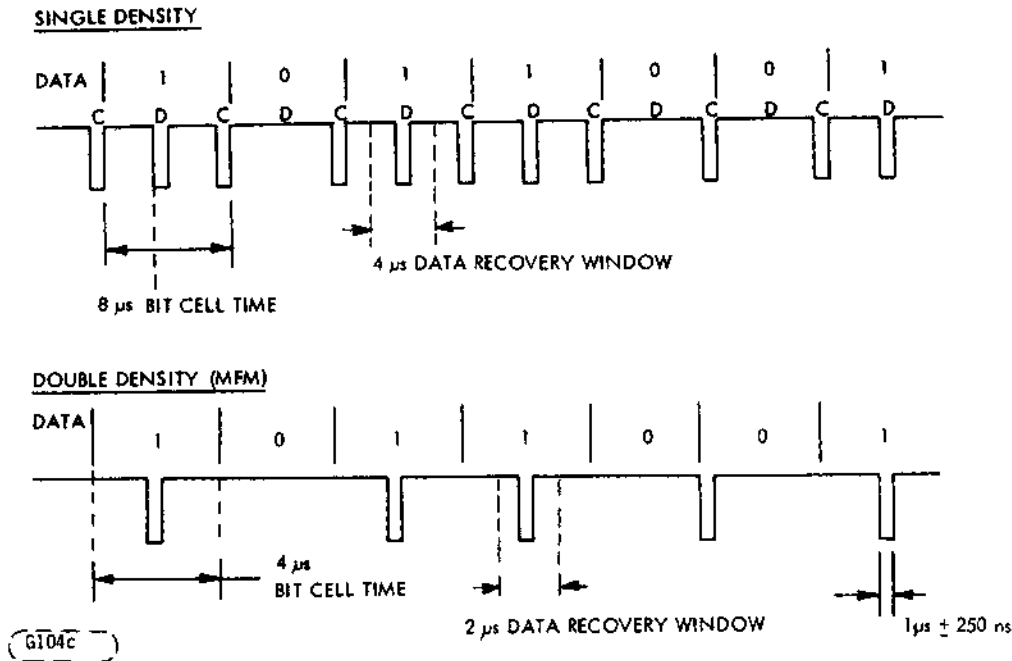

Figure 5. Nominal Data Timing

8.1.2.1 Write Precompensation

Write precompensation is required to decrease the effect of bit shift on the reduced bit cell and window of MFM data. The window is defined as being the total time allowed for the bit to appear and be recognized. The data recovery window of MFM is 2 microseconds as opposed to the FM window of 4 microseconds. The amount of write precompensation is 250 nanoseconds early or late in relation to nominal.

Write precompensation should be applied to all tracks, 0 through 39, on both sides of the disk.

Write precompensation is applied to data patterns that will result in a large amount of bit shift. The controller precompensation circuit looks at three bits on each side of a reference bit and determines whether or not to shift. (PLO and Write Precompensation Application Note is available on request.) The following patterns are compensated (bit-shifted) in the direction of the arrow.

		PC	SPEC. NO.	SHEET	REV.
		A	77653379	15	A

PRODUCT SPECIFICATION FOR THE 9409 FDD

8.1.2.1 -contd.

LATE	EARLY
$\begin{array}{c} \rightarrow \\ X\ 0\ 1\ 1 \\ \rightarrow \\ 1\ 0\ 0\ 0 \end{array}$	$\begin{array}{c} \leftarrow \\ X\ 1\ 1\ 0 \\ \leftarrow \\ 0\ 0\ 0\ 1 \end{array}$

X = Don't Care

The following is an explanation of the MFM write precompensation algorithm. When a flux transition pattern of 011 is written on the disk, the first 1 is shifted toward the 0 (data bit cell with or without flux transition). Write precompensation shifts this 1 in the opposite direction the amount of the expected shift. In the case of the 1000 pattern, the second 0 (clock bit) shifts toward the first 0 (data bit cell with no flux transition) and this clock bit is compensated late towards the third 0 (clock bit). With pattern 110 the second 1 shifts toward the 0 (bit cell with no transition) so this 1 data bit is compensated early towards the first 1 data bit. In the last pattern 0001, the third 0 (clock bit) is shifted towards the 1 (data bit) due to the nominal 6 microseconds between these two bits. Thus, the third 0 (clock bit) is compensated early towards the second 0 to counteract shifting towards the 1.

8.2 FORMAT CONSIDERATIONS

Design of the 9409 allows for data recording using either hard or soft sector formats. The following operational tolerances should be considered when selecting a particular format for the system. For additional information consult Application Note 75897469, 5.25-Inch FDD Format Considerations and Controller Compatibilities.

8.2.1 Index Tolerance

8.2.1.1 Post Index

Before initial recording of data upon a selected track, a minimum gap time of 1 millisecond is required to allow for drive-to-drive and adjustment tolerance.

8.2.1.2 Pre-Index

To compensate for drive-motor speed tolerances, a minimum gap spacing of 7.2 milliseconds is required.

		PC	SPEC. NO.	SHEET	REV.
		A	77653379	16	A

PRODUCT SPECIFICATION FOR THE 9409 FDD

8.2.2 Inter-Record Tolerance

8.2.2.1 Pre-Address

The Pre-address length is a minimum of 1.64 milliseconds, but varies with sector size for 128-byte sector lengths. The pre-address gap timing is Gap No. 3 and is based on the tunnel-erase structure of the read/write head and maximum erase-circuit turn-off delay.

8.2.2.2 Pre-Data

Pre-data gap is Gap No. 2 and has a minimum timing requirement of 489 microseconds. Gap timing is determined by the erase turn-on circuit tolerance and the tunnel-erase structure of the read/write head.

8.2.3 Soft-Sector Formatting

For system use of soft-sector formatting, Figure 6 provides several recommended timing tolerances for individual gaps positioned within the format. For soft-sector formats utilizing MFM recording, Figure 7 presents the minimum gap for timing tolerances required for this recording scheme.

8.2.4 Hard-Sector Formatting

Hard-sector formats use sector holes in the diskette to separate the track into sectors. The mechanical and electrical parameters of flexible disk drives and media require the format to consist of three parts--Preamble, User Data, and Postamble.

The Preamble consists of a defined number of gap bytes that are written starting at the beginning of the sector pulse. The Preamble length is defined so that under worst-case conditions User Data will not be lost due to sector pulse jitter or erase delays.

PRODUCT SPECIFICATION FOR THE 9409 FDD

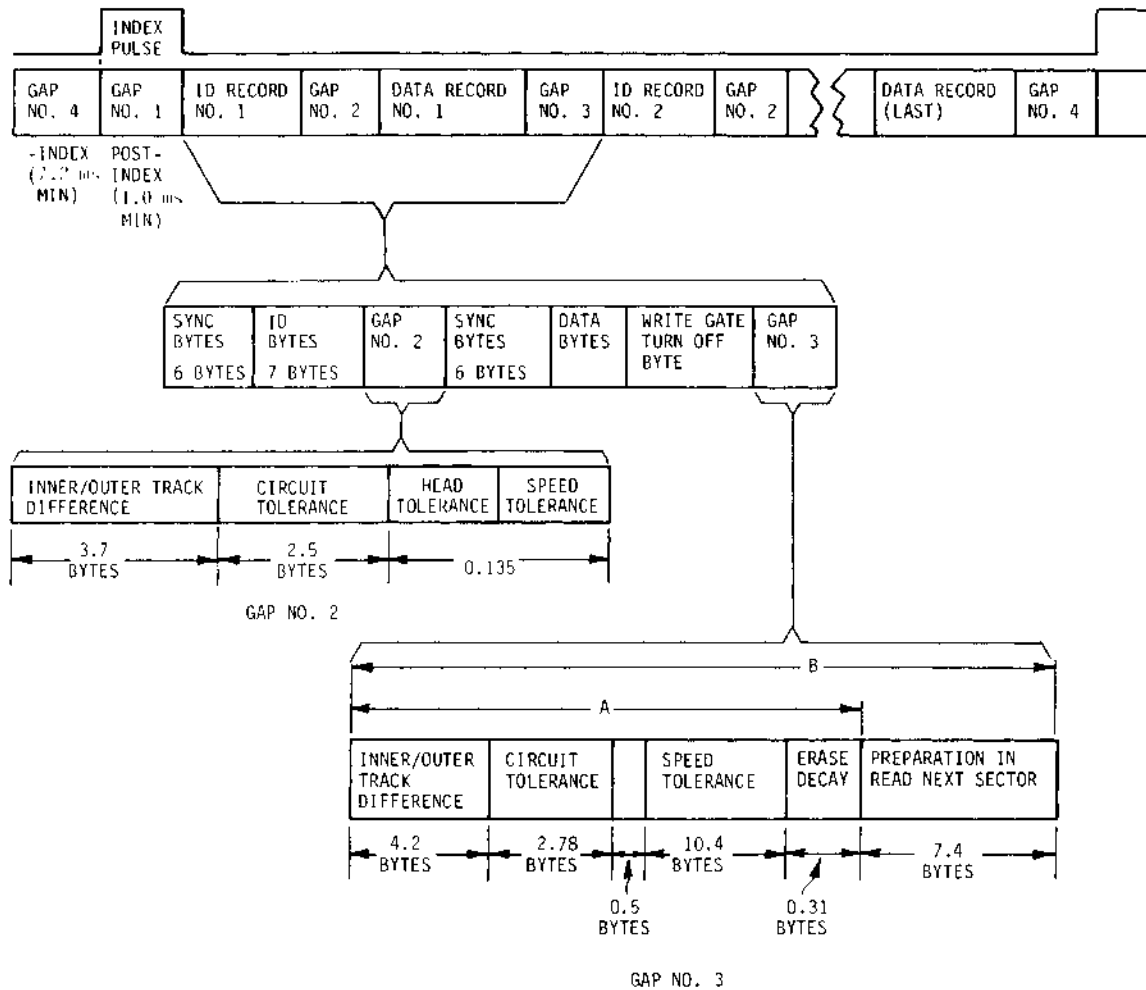

A - 18.2 BYTES - TO PREVENT DATA LOSS UNDER WORST-CASE CONDITIONS.

B - 25.6 BYTES - GUARANTEES CONSECUTIVE SECTOR OPERATION UNDER WORST CASE CONDITIONS.

22102b

Figure 6. Minimum Requirements for Single-Density Soft-Sector Format (Part 1)

		PC A	SPEC. NO. 77653379	SHEET 18	REV. A
--	--	---------	-----------------------	-------------	-----------

PRODUCT SPECIFICATION FOR 9409 FDD

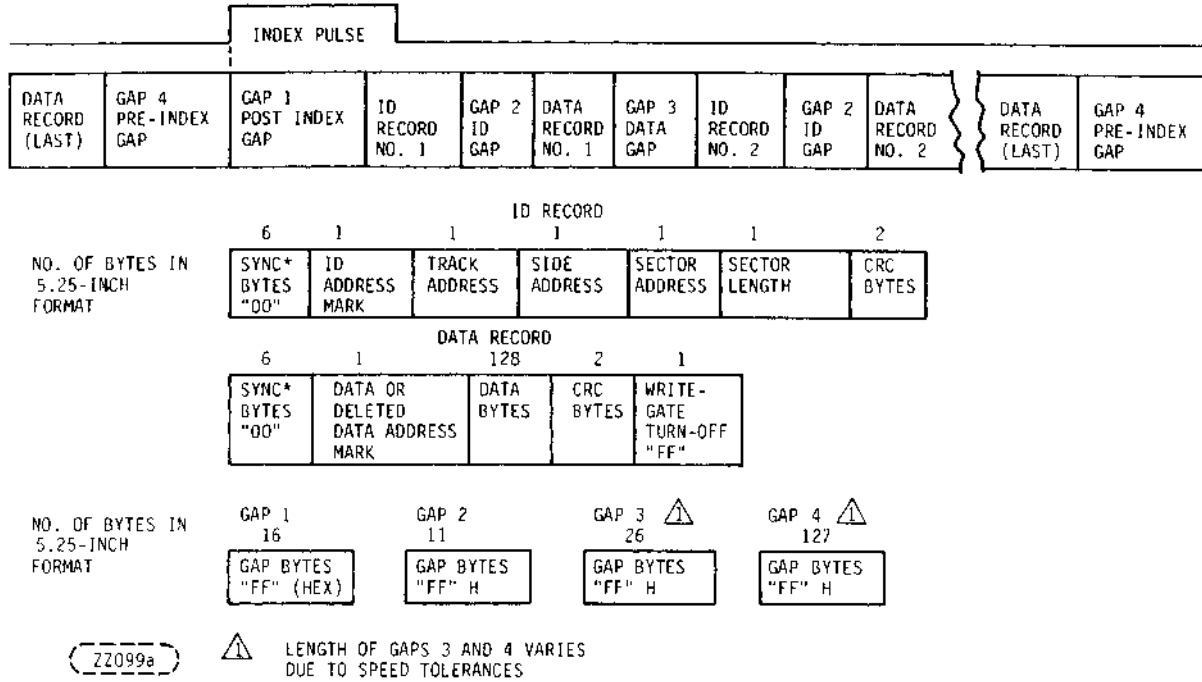

Figure 6. Minimum Requirements for Single-Density Soft-Sector Format (Part 2)

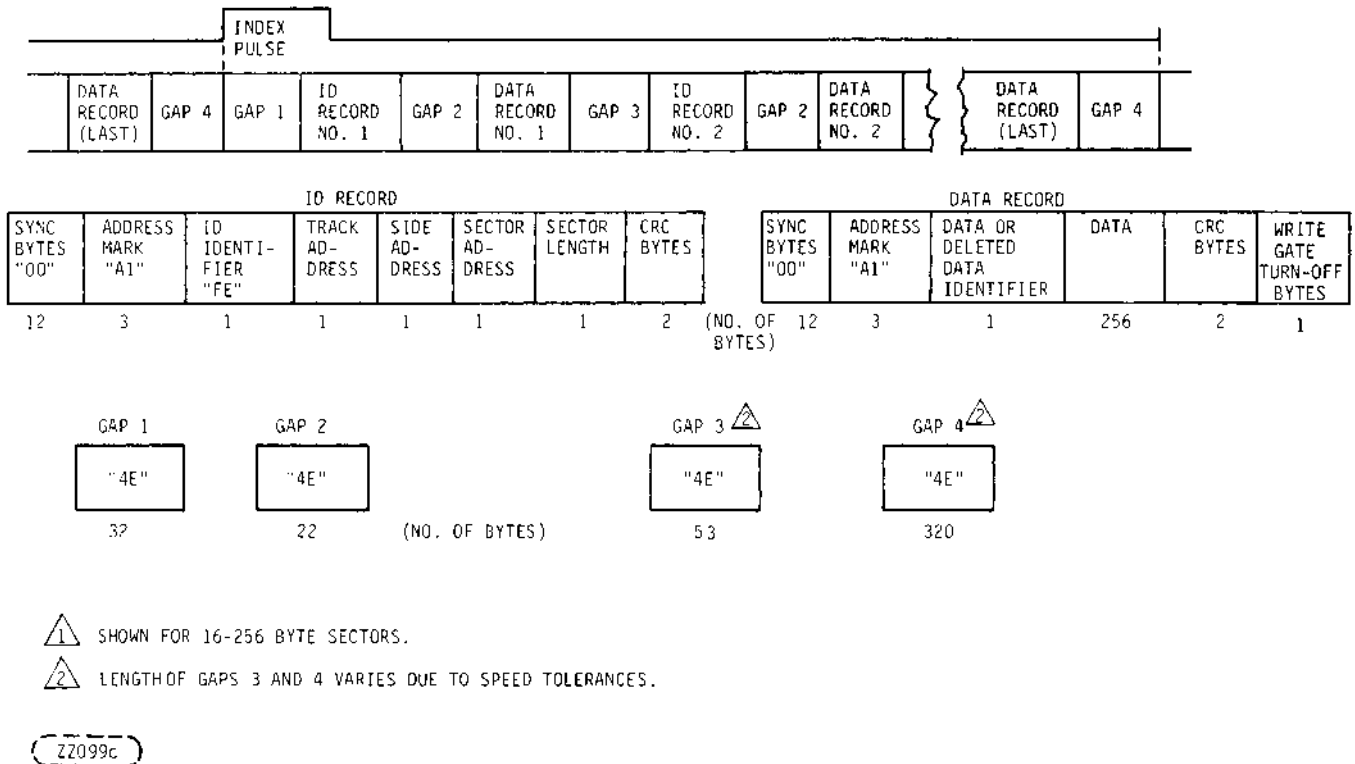

Figure 7. Recommended Double-Density Format

		PC A	SPEC. NO. 77653379	SHEET 19	REV. A
--	--	---------	-----------------------	-------------	-----------

PRODUCT SPECIFICATION FOR THE 9409 FDD

8.2.4 -contd.

User Data consists of data, sync bytes, ID bytes, and CRC bytes used by the particular format. User Data and the Preamble are both written each time a sector is updated.

A buffer zone, or Postamble, is required at the end of a sector between the User Data and the earliest sector pulse.

Recommended minimum Preamble and Postamble gaps are given in Table 2 and illustrated in Figure 8.

Table 2. Recommended Preamble/Postamble Gap

POSTAMBLE		BLANK (NO CHARACTER WRITTEN)	ZEROES (CHARACTER WRITTEN)
16 SECTORS PER TRACK	MINIMUM PREAMBLE	8 BYTES	24 BYTES
	MAXIMUM USER DATA	156 BYTES	148 BYTES
	MINIMUM POSTAMBLE	22 BYTES	15 BYTES
10 SECTORS PER TRACK	MINIMUM PREAMBLE	8 BYTES	23 BYTES
	MAXIMUM USER DATA	269 BYTES	261 BYTES
	MINIMUM POSTAMBLE	27 BYTES	19 BYTES

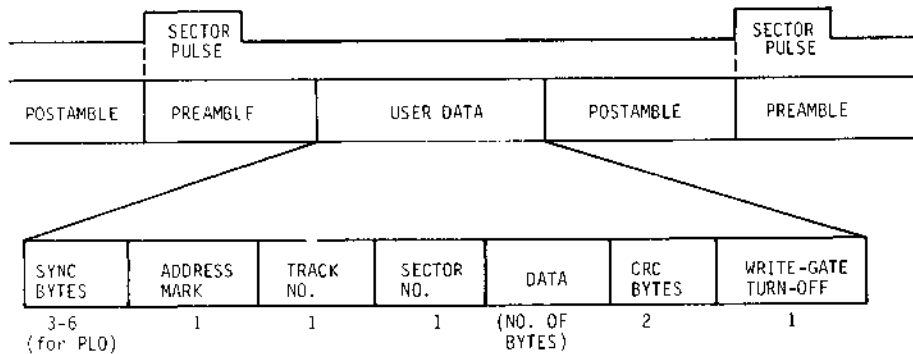

ZZ099b

Figure 8. Recommended Hard-Sector Format

		PC	SPEC NO.	SHEET	REV
		A	77653379	20	A

PRODUCT SPECIFICATION FOR THE 9409 FDD

8.2.4 -contd.

As shown in Table 2, there are two ways to configure the Postamble Field, Blank and Zeroes.

1. Blank (No Character Written) - the controller can turn off write data at the end of the User Data field and leave the Postamble as an empty or blank field.
2. Zeroes (Character Written) - the write gate can turn off write data at the beginning of the next sector pulse. When doing this, the controller must write gap characters; e.g., all zeroes in the Postamble field.

The write gate turn off at the end of the User Data field is recommended because it allows the use of a larger User Data field. The values given for maximum User Data field guarantee maximum recovery for read-after-write operation under worst-case conditions.

9.0 INSTALLATION INFORMATION

9.1 ELECTRICAL INTERFACE

The electrical interface between the 9409 and host system consists of two primary connectors. The I/O signal connector J1 contains all interface signals transmitted to and from the drive. Connector J2 supplies DC power to the 9409. AC power is not applicable to this device. A separate frame ground connection is available at the rear of the unit.

See Figure 9 for interface connections and Figure 10 for connector locations.

9.2 POWER CONNECTOR

There is no AC power connector on the 9409.

DC power is provided to the 9409 by the host system through connector J2, which is mounted on the non-component side of the printed circuit board near the spindle drive motor. Refer to Figure 10 for connector location and Table 3 for pin assignments. Table 4 lists the recommended mating connector for J2.

		PC	SPEC NO.	SHEET	REV
		A	77653379	21	A

PRODUCT SPECIFICATION FOR THE 9409 FDD

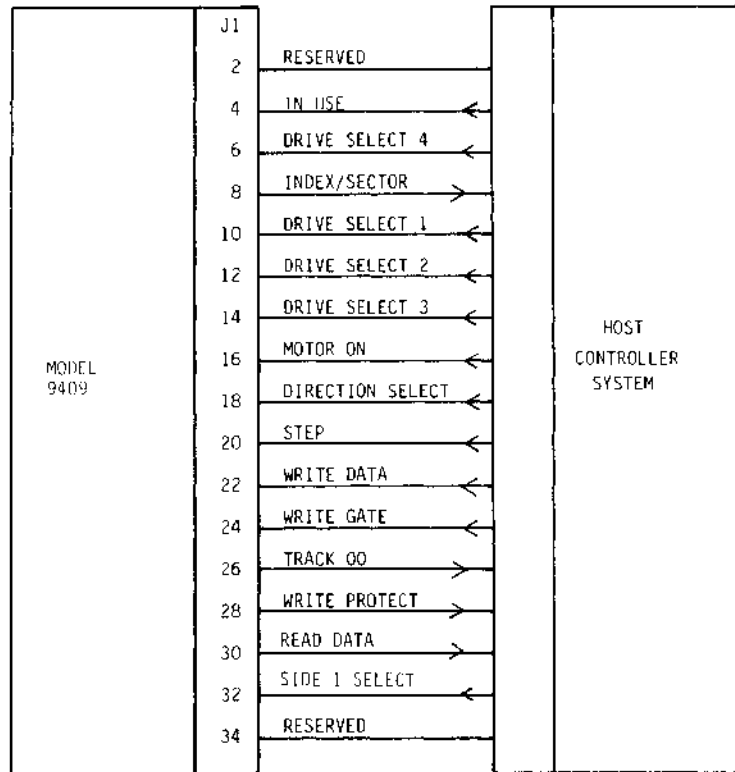

ALL J1 ODD-NUMBER PINS DC GROUND

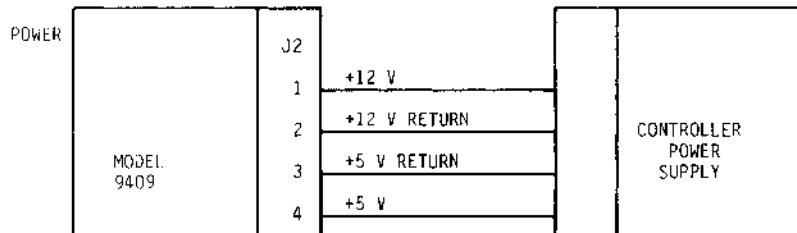

G106b

Figure 9. Interface Connections

		PC A	SPEC NO. 77653379	SHEET 22	REV A
--	--	---------	----------------------	-------------	----------

PRODUCT SPECIFICATION FOR THE 9409 FDD

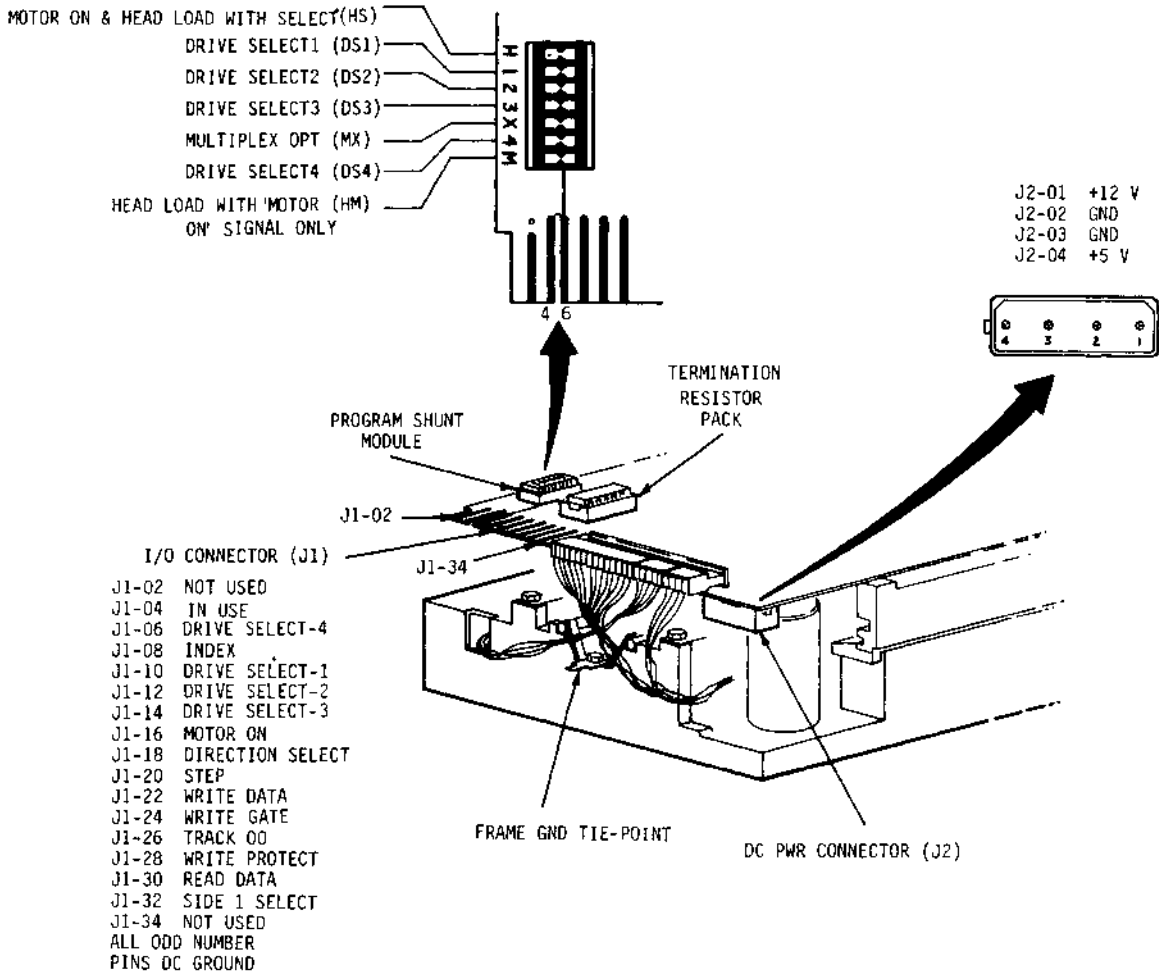

G080a

Figure 10. Input/Output (J1), DC Power (J2), Terminator, and Programmable Shunt Module Location/Description

		PC	SPEC. NO.	SHEET	REV.
		A	77653379	23	A

PRODUCT SPECIFICATION FOR THE 9409 FDD

Table 3. DC Interface

POWER LINE DESIGNATION	PIN NUMBER
+12 VOLTS	J2-01
+12 VOLTS RETURN	J2-02
+5 VOLTS RETURN	J2-03
+5 VOLTS	J2-04

Listed in Table 4 is connector information for J2/P2.

Table 4. J2/P2

TYPE OF CABLE	CONNECTOR	CONTACTS
	J2, 4-pin AMP Mate-N-Lok 350211-1	
18 AWG	P2, AMP 1-480424-0	AMP 61473-1

9.3 I/O CONNECTOR

The I/O connector J1 is a 34-pin PCB edge connector. Its location is shown in Figure 10. The dimensions for J1 are shown in Figure 11. The pins are numbered 1 through 34, with the even-numbered pins appearing on the component side of the PCB and odd-numbered pins on the non-component side. A key slot is provided between pins 4 and 6 for optional connector keying.

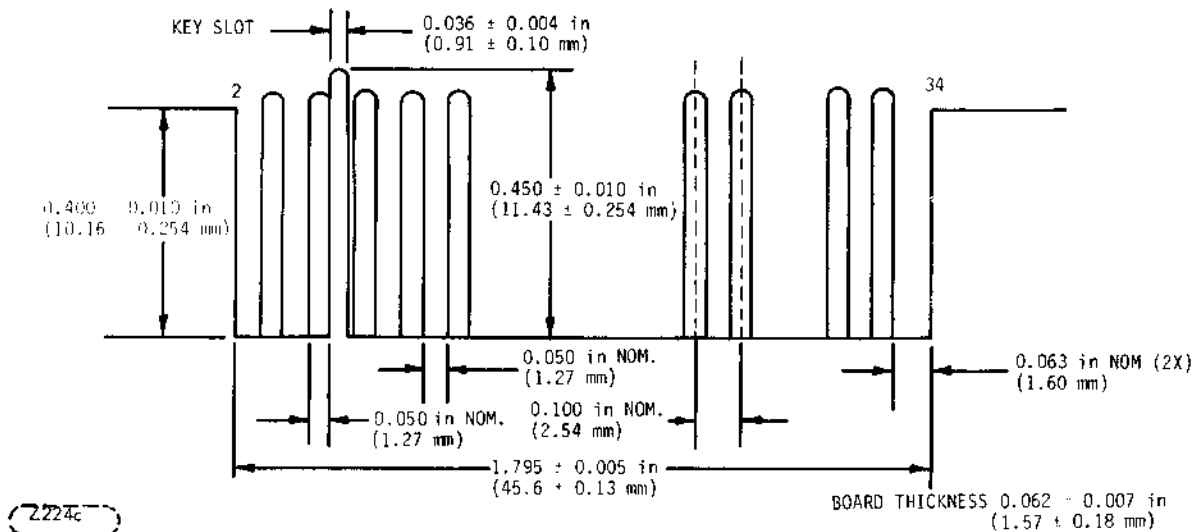

Figure 11. I/O Connector (J1) Dimensions

		PC	SPEC. NO.	SHEET	REV
		A	77653379	24	A

PRODUCT SPECIFICATION FOR THE 9409 FDD

9.3 -contd.

The **maximum** I/O cable length between the host controller and the 9409 (or last FDD in daisy chain configuration) should be no greater than 10 feet.

The recommended mating connector for J1 and type of cable are shown in Table 5.

Table 5. J1/P1

TYPE OF CABLE	CONNECTOR	CONTACTS
TWISTED PAIR, 26 AWG	AMP 583717-5	AMP 1-583616-4
FLAT CABLE	3M SCOTCHFLEX 3463-0001	---
---	AMP KEYING PIN 583274-2	---

9.4 GROUNDING REQUIREMENTS

To ensure optimum performance and noise immunity, the 9409 must be frame grounded to the host equipment AC ground. A Faston tab has been provided on the rear of the casting where its mating Faston connector can be attached or soldered. The tab is AMP part number 61664-1 and its mating connector is AMP part number 60972-1.

9.5 CONFIGURATIONS

9.5.1 Daisy-Chain Configuration

A **daisy-chain** configuration incorporates interfacing of the disk drives on a **common** I/O cable. Only the FDD which is selected by the host system has its control and data signals enabled through this common interface. The program shunt module shown in Figure 10 allows creation of each individual drive-selection address for each drive in the daisy-chain. Four drive selection addresses are made available by the program shunt module for interfacing up to four drives in a daisy chain configuration (shown in Figure 12).

Refer to paragraph 12.0 for descriptions of drive selection and head load options.

Termination in a daisy chain configuration is described in paragraph 9.6.3.

		PC	SPEC NO.	SHEET	REV.
		A	77653379	25	A

PRODUCT SPECIFICATION FOR THE 9409 FDD

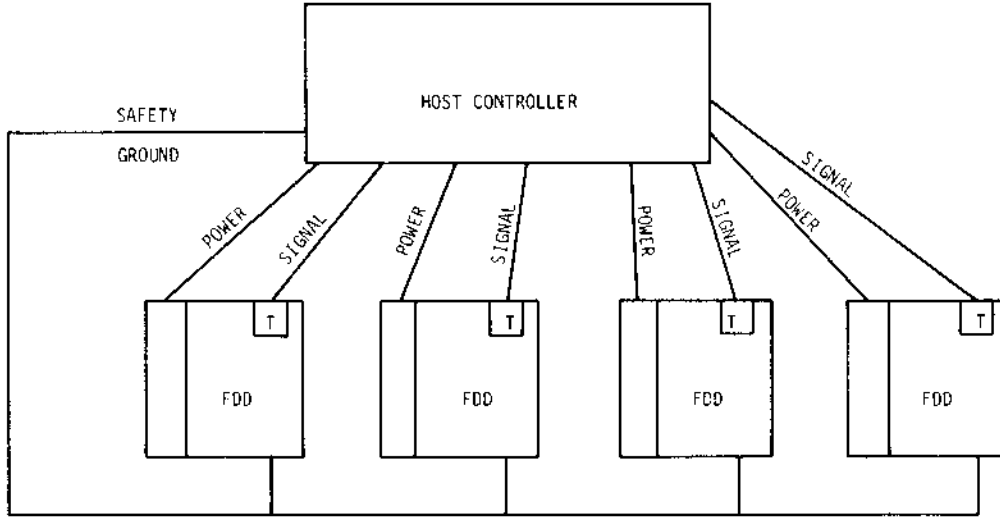

RADIAL CONFIGURATION

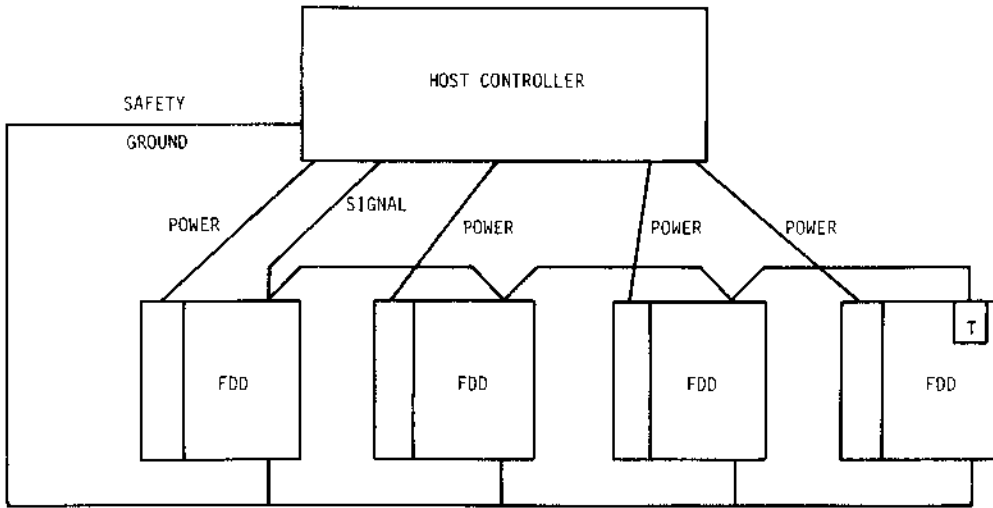

DAISY-CHAIN CONFIGURATION

ZZ1013

T INDICATES PRESENCE OF RESISTOR TERMINATOR PACK.

Figure 12. FDD System Connection Configurations

		PC	SPEC. NO.	SHEET	REV
		A	77653379	26	A

PRODUCT SPECIFICATION FOR THE 9409 FDD

9.5.2 Radial Configuration

In a radial configuration the disk drives do not share the same I/O cable. Each drive is interfaced to its own I/O cable which, in turn, allows interfacing of more than four drives and a variety of system operational techniques. Drive-selection addressing must be accommodated at the program shunt module to allow activation of I/O signals.

Refer to paragraph 12.0 for descriptions of drive select and head load options.

A radial configuration is shown in Figure 12 and termination is described in paragraph 9.6.2.

9.6 INTERFACE TERMINATIONS

Figure 13 provides a logical representation of the interface line termination used for the 9409.

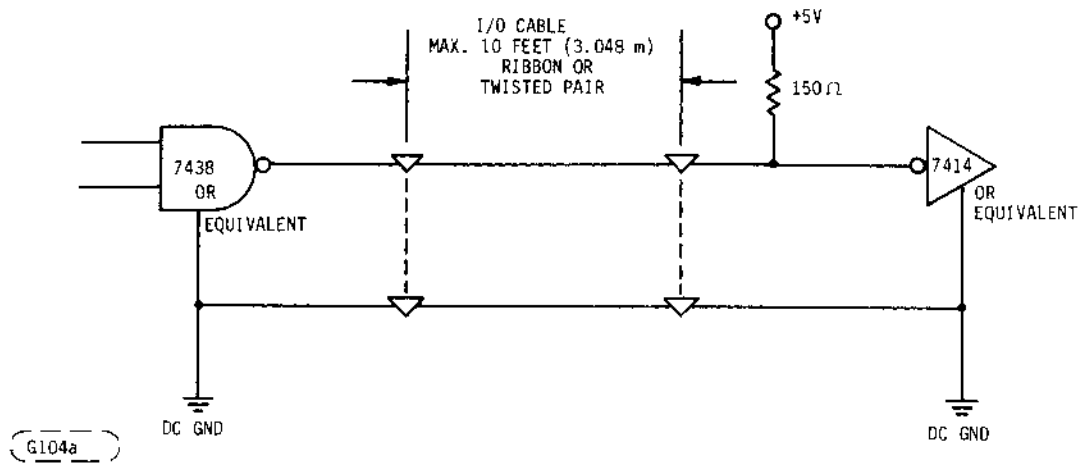

Figure 13. Interface Terminations

		PC	SPEC. NO.	SHEET	REV.
		A	77653379	27	A

PRODUCT SPECIFICATION FOR THE 9409 FDD

9.6.1 Areas of Termination

Termination for each input line is accommodated by a 150-ohm resistor pack installed in a DIP socket located on the PCB of the 9409 (Figure 10).

9.6.2 Termination of a Radial Configuration

In a single drive or radial configuration, the resistor pack must be kept in place on each PCB to provide the proper terminations.

9.6.3 Termination in a Daisy-Chain Configuration

In a daisy-chain configuration, only the last drive on the interface is to be terminated. All other drives on the interface must have the resistor pack removed.

9.6.4 External Terminations

For configurations requiring external termination, the user must terminate each input line to +5 V DC through a 150-ohm, 1/4-watt resistor.

10.0 ERROR RECOVERY

Seek errors will rarely occur unless the stepping rate is exceeded. In the event of a seek error, recalibration of track location can be achieved by repetitive step-out commands until a Track 00 signal is received.

To guard against degradation from imperfections in the media, no more than three attempts to write a record should be attempted when read-after-write errors are encountered. If a record cannot be successfully written within four attempts, it is recommended that the sector or track be labeled defective and an alternate sector or track assigned. If more than two defective tracks are encountered, it is recommended that the diskette be replaced.

In the event of a read error, up to 10 attempts should be made to recover with reread operations. If after 10 attempts the data has not been recovered, step the head several tracks away and then reposition to recover the data. Unloading the head when data transfers are not imminent will increase the data reliability and extend diskette life.

		PC	SPEC. NO.	SHEET	REV.
		A	77653379	28	A

PRODUCT SPECIFICATION FOR THE 9409 FDD

11.0 INTERFACE SIGNAL DESCRIPTION

11.1 ACTIVE/INACTIVE LOGIC SIGNALS

<u>Signal State</u>	<u>Logic Level</u>	<u>Voltage</u>
Inactive (False)	Logic 0/High	+2.5 V to +5.25 V
Active (True)	Logic 1/Low	0.0 V to +0.4 V

11.2 Input Signals

11.2.1 Drive Select

Drive Select (J1-6, -10, -12, -14) activates the internal circuitry of a selected drive. Activating this line to a logic low (active) level will condition the drive's input and output lines. All input and output lines are gated with drive select with the exception of Motor On (J1-16) and In Use (J1-02).

After the activation of the Drive Select line, a minimum time delay is required before the start of any write or read operation (see Figures 14 and 17). See Table 6 for these minimum time delays which are dependent on drive shunt configuration.

Table 6. Minimum Time Delays

MODE OF OPERATION	TIME TO VALID READ DATA
1. Motor up to speed and head loaded.	2 microseconds
2. Motor up to speed, then load the heads.	50 milliseconds
3. Motor on when drive selected.	0.5 seconds

The operation of the Drive Select lines and selection of a designated drive is controlled through the programmable shunt position DS1, DS2, DS3, and DS4. Refer to section 12.0 for further information.

11.2.2 Motor On

The Motor On circuit can be configured to operate in the three different ways described below.

1. If shunt HM is shorted and HS is open, the drive motor will turn on and the head will load when a logic low is applied to Motor On line J1-16. There is a minimum 0.5 second delay from active Motor On until there is valid read data.

		PC	SPEC. NO.	SHEET	REV.
		A	77653379	29	A

PRODUCT SPECIFICATION FOR THE 9409 FDD

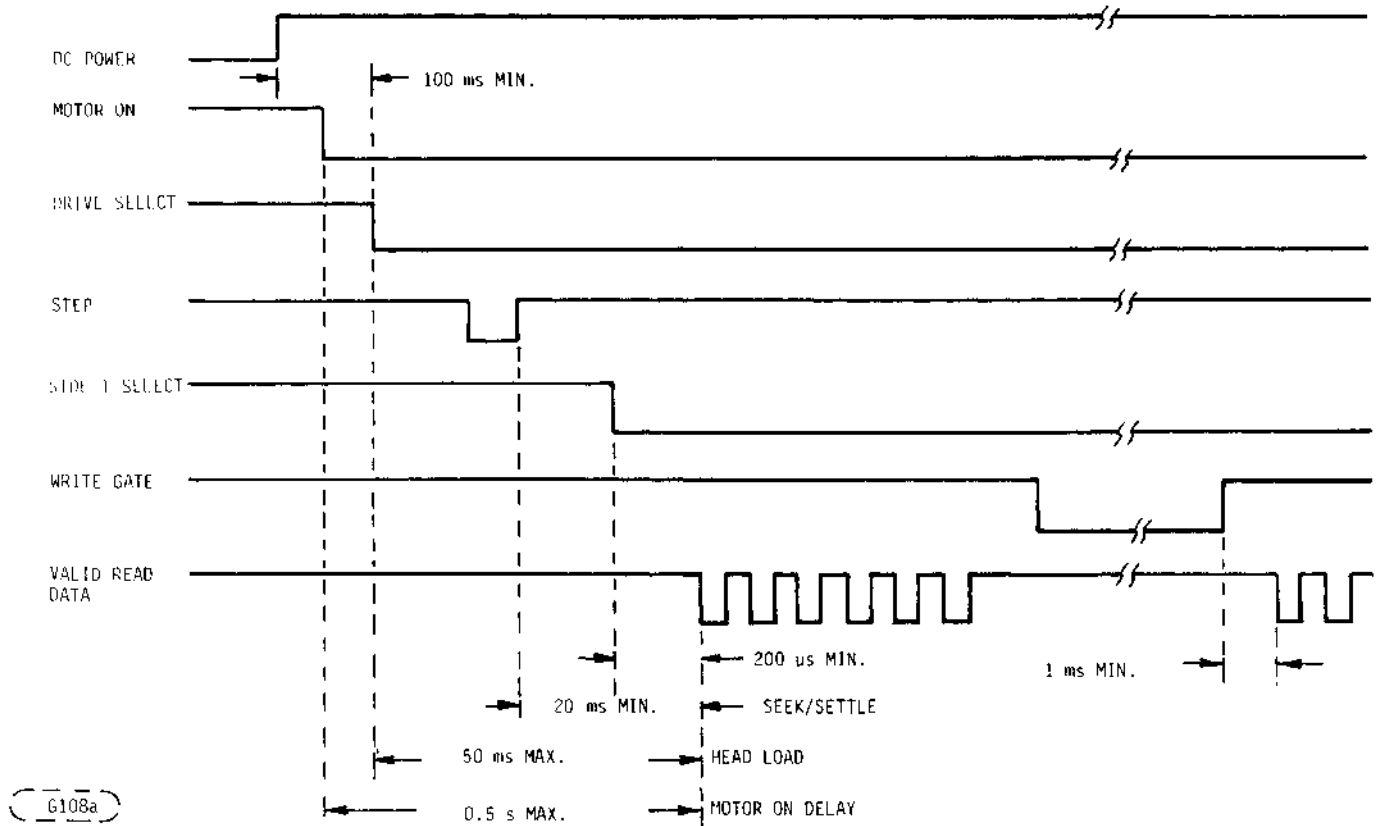

Figure 14. Read Initiate Timing

11.2.2 -contd.

- a. The advantage of this configuration is that after initial motor up-to-speed delay, the drive can be selected (Drive Select line active) and there is a maximum of 2 microseconds to valid read data. (Motor must be on and head-loaded for this to be valid).
 - b. The disadvantage of this configuration is that with motor on and head loaded at all times, there is increased wear to drive motor, media, and heads.
2. If shunt HS is shorted and shunt HM is open, the drive motor will turn on when a logic low is applied to any of the drive select lines J1-6, -10, -12, or -14. This configuration uses the drive select line to start the motor and load the heads. The minimum delay from drive selection to valid read data is now 0.5 second due to the delay for motor start time.

		PC	SPEC. NO.	SHEET	REV.
		A	77653379	30	A

PRODUCT SPECIFICATION FOR THE 9409 FDD

11.2.2 -contd.

- a. The advantage of this configuration is reduced motor, media, and head wear because motor, media, and heads are only used when needed (selected).
 - b. The disadvantage of this configuration is that the maximum time from drive selection to valid read data is 0.5 second.
3. Same as Configuration 2 (HS shorted and HM open), except that logic low on Motor On can start the motor. Then, at Drive Select and head is loaded and the drive is selected. If the drive is operated in this manner after an initial motor up-to-speed delay, there is a maximum 50 millisecond delay to allow for head load time until valid read data.

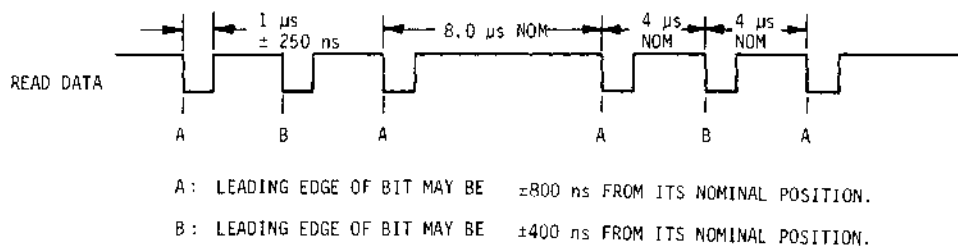

ZZ096b

Figure 15. Read Signal Timing

11.2.3 Direction Select

Direction Select (J1-18) transfers a control signal to determine the direction the read/write head will move when the step line is pulsed.

A logic high defines the direction as "out," and if a pulse is applied to the Step line, the read/write head will move away from the center of the disk. Conversely, if this input is a logic low level, the direction of motion is defined as "in," and if a pulse is applied to the Step line, the read/write head will move toward the center of the disk. Refer to Figure 16 for timing details.

11.2.4 Step

Step (J1-20) pulses are control signals which cause the read/write head to move in a direction determined by the condition of the Direction Select line.

		PC A	SPEC. NO. 77653379	SHEET 31	REV. A
--	--	---------	-----------------------	-------------	-----------

PRODUCT SPECIFICATION FOR THE 9409 FDD

* NOTE: STEPPING IS INHIBITED WHEN WRITE GATE IS ENABLED.

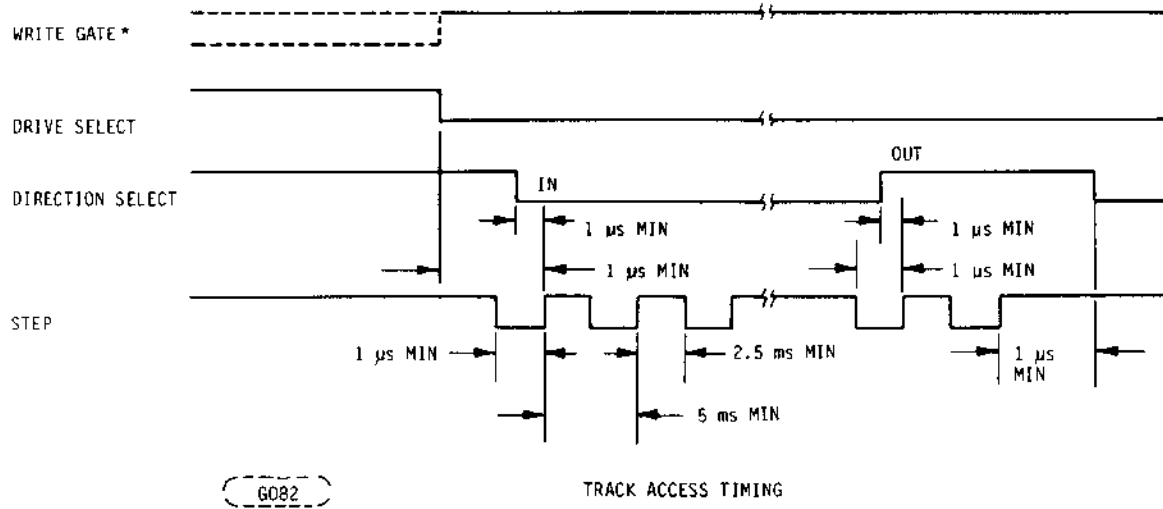

Figure 16. Track Access Timing

11.2.4 -contd.

Access motion is initiated on each logic low to logic high transition, or on the trailing edge of each signal pulse. Any change in the Direction Select line must be made at least 1 microsecond before the trailing edge of the Step pulse. A requirement exists for the Direction Select logic level to be maintained 1 microsecond after the trailing edge of the Step pulse.

Activation of the Write Gate line while using a write-protected diskette will not inhibit movement of the read/write head during transmission of Step pulses.

Refer to Figure 16 for timing details.

11.2.5 Write Gate

The active state of Write Gate (J1-24), or logic low, enables Write Data to be written on the diskette. The inactive state, or logic high, enables the Read Data logic and Step logic.

A maximum delay time of 8 microseconds is allowed between the switching sequence of the Write Gate line and the leading edge of the first data pulse to be recorded. Figure 17 illustrates this sequence of events.

		PC	SPEC. NO.	SHEET	REV.
		A	77653379	32	A

PRODUCT SPECIFICATION FOR THE 9409 FDD

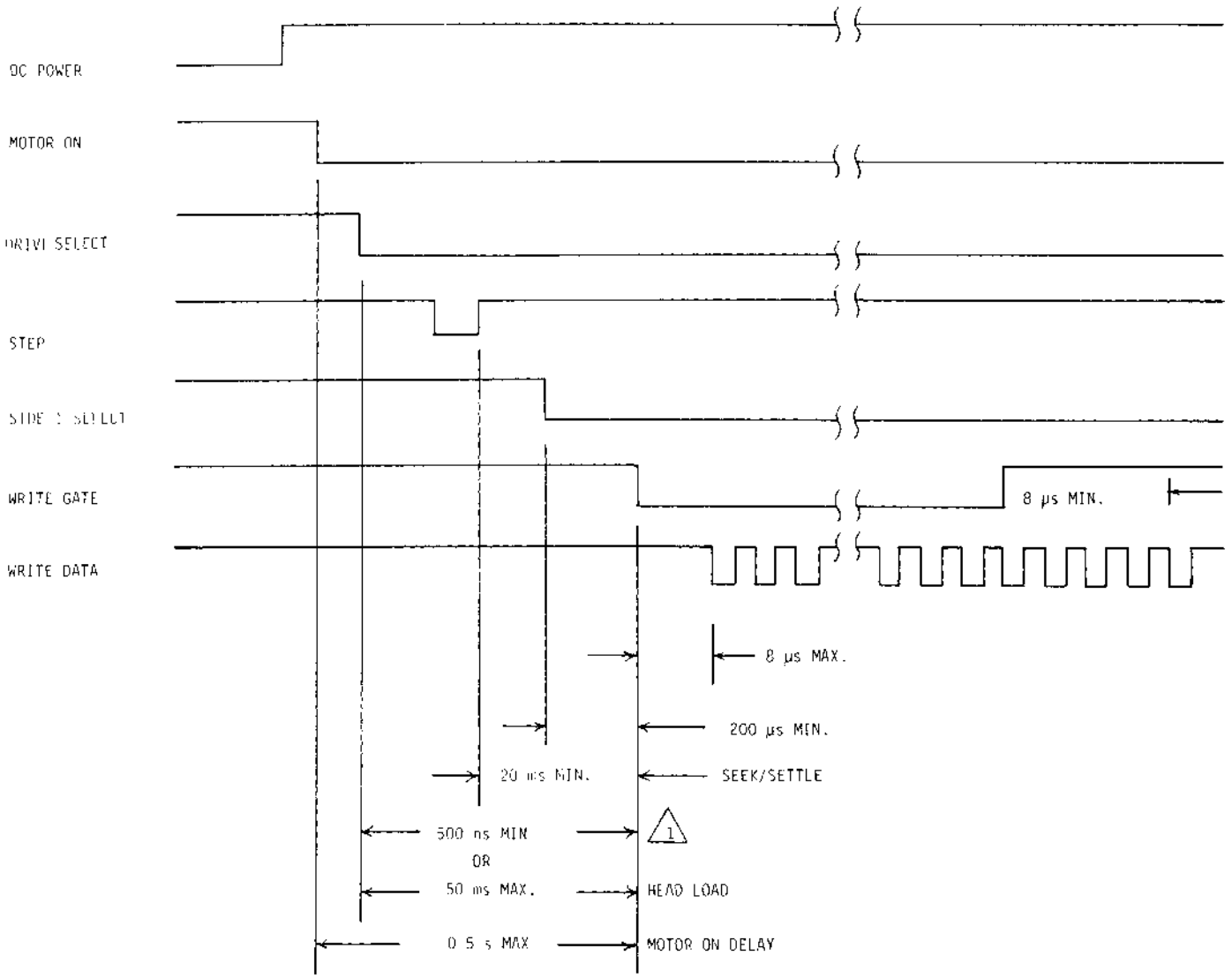

1 ASSUMES HEAD IS LOADED AND MOTOR IS UP TO SPEED WHEN DRIVE IS SELECTED.

G105

Figure 17. Write Initiate Timing

11.2.6 Write Data

Write Data (J1-22) provides data to be written on the diskette. Each pulse transition from a logic high to a logic low level, as clocked through a D flip-flop within the logic circuitry, will cause current through the read/write head to reverse, creating a data bit.

		PC	SPEC. NO.	SHEET	REV.
		A	77653379	33	A

PRODUCT SPECIFICATION FOR THE 9409 FDD

11.2.6 -contd.

Signals transmitted on the Write Data line are transmitted in the form of clock/data composite pulses. The recommended pulse width for both data bit and clock pulse is 200 nanoseconds (minimum) and 2.1 microseconds (maximum). Generation of data on the media is possible only during activation of the Write Gate to a logic low level. Figure 18 illustrates these timing sequences. Refer to paragraph 8.1.2.1 for recommended write precompensation.

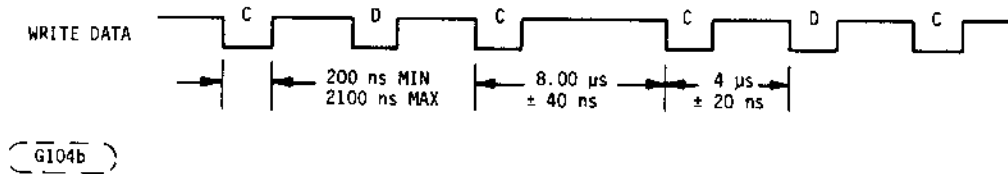

Figure 18. Write Data Timing (FM)

11.2.7 Read/Write Operations

At the conclusion of a write or read operation, there are a number of timing considerations which must be observed.

1. After any write operation, there is a 1-millisecond minimum time delay to allow for the erase turn-off delay required with the tunnel erase head. Interface signals which must remain in a stable state during this delay are: a) Drive Select, b) Head Load, c) Motor on, d) Side 1 Select, and 3) Step. This can be considered as write-operation-to-read-operation time.
2. If a side change occurs at the termination of a write operation, the side change delay of 200 microseconds plus the 1-millisecond erase-turn-off delay is required; that is, a total of 1200 microseconds. This is write-to-read time including a side change.
3. In going from a read operation to a read-operation-including-a-side-change, only the side change delay of 200 microseconds must be observed.

Refer to Figure 19 for detailed timing.

		PC	SPEC. NO.	SHEET	REV.
		A	77653379	34	A

PRODUCT SPECIFICATION FOR THE 9409 FDD

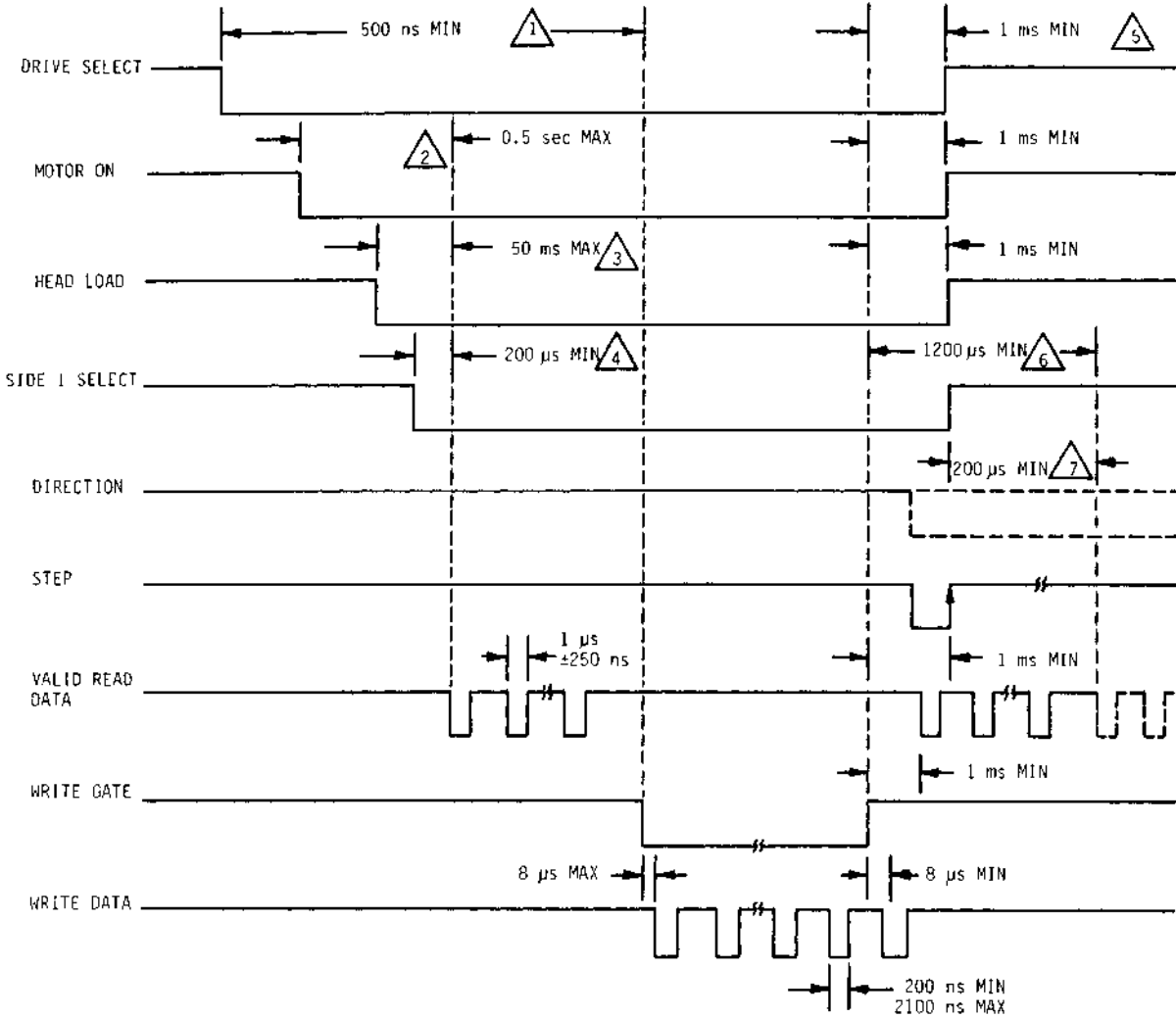

- △1 ASSUMES MOTOR ON AND HEAD LOADED.
- △2 ASSUMES HEAD LOADED DURING MOTOR ON TIME DELAY.
- △3 ASSUMES MOTOR UP TO SPEED.
- △4 ASSUMES MOTOR UP TO SPEED AND HEAD LOADED.
- △5 THE 1 ms IS THE ERASE TURN-OFF DELAY REQUIRED FOR TUNNEL ERASE HEADS.
- △6 THE 1200 μs IS THE ERASE TURN-OFF DELAY PLUS SIDE CHANGE DELAY.
- △7 THE 200 μs IS REQUIRED FOR A CHANGE IN SIDE CHANGE.

G237

Figure 19. Read/Write Operations

		PC	SPEC. NO.	SHEET	REV.
		A	77653379	35	A

PRODUCT SPECIFICATION FOR THE 9409 FDD

11.2.8 Track 00

The active or logic low state of the Track 00 signal (J1-26) indicates the read/write head is positioned at track 00.

This signal is at a logic high level (inactive state) when the read/write head is not at track 00.

When the read/write head is at track 00, and an additional step-out pulse is issued to the drive, motion is inhibited and the Track 00 signal will remain active (logic low).

11.2.9 Index/Sector

The Index/Sector signal (J1-8) is detected and transmitted to the controller each time an index or sector hole is sensed by the index/sector photocell detector.

The signal generated is a 0.5 millisecond (min.) pulse which indicates the presence of an Index or Sector hole during its transition from a logical one to a logical zero level as shown in Figure 20.

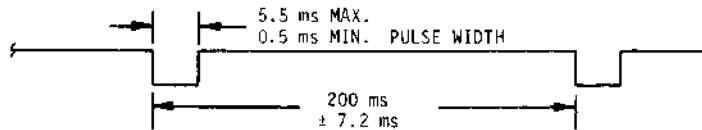

ZZ096d

Figure 20. Index Timing (Soft-Sector Media)

		PC	SPEC. NO.	SHEET	REV.
		A	77653379	36	A

PRODUCT SPECIFICATION FOR THE 9409 FDD

11.2.9 -contd.

Using soft-sectored media, a single pulse will be generated per revolution of the diskette, every 200 ± 7.2 milliseconds, indicating the physical beginning of a track.

Using hard-sectored media (16 or 10 sectors), 17 or 11 pulses, respectively, will be generated per revolution. Figures 21 and 22 provide an illustration of index/sector timings for 16 and 10 sector applications.

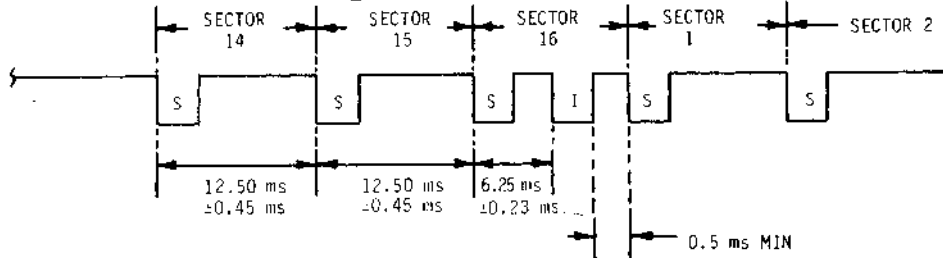

ZZ101b

Figure 21. Index/Sector Timing (16 Hard-Sector Media)

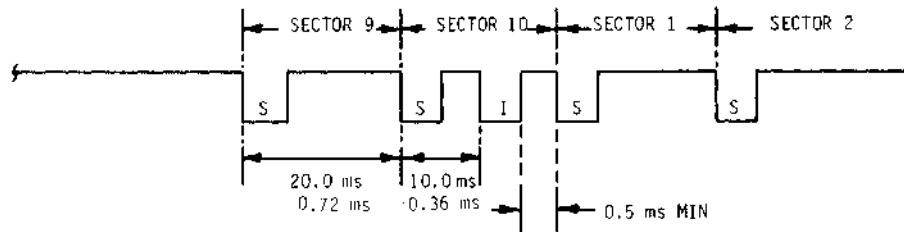

ZZ101c

Figure 22. Index/Sector Timing (10 Hard-Sector Media)

11.2.10 Read Data

Read Data (J1-30) provides a transmission of composite clock and data pulses of 1 microsecond, ± 250 nanoseconds, to indicate the presence of either a clock or data pulse by means of a logic high to a logic low transition. Figures 14 and 15 provide references for timing and bit shift tolerance within normal media variations.

11.2.11 Write Protect

Write Protect (J1-28) notifies the user that a write protected diskette (i.e., when the write protect slot on the diskette is masked) is installed in the drive. The normal configuration is that a logic low level will appear on the interface line J1-28 indicating that the diskette is write protected and writing will be inhibited.

		PC	SPEC. NO.	SHEET	REV.
		A	77653379	37	A

PRODUCT SPECIFICATION FOR THE 9409 FDD

11.2.11 -contd.

If it is necessary to invert this output signal so that an unmasked slot gives a write protect indication and inhibits writing, the user must move the black wire on the write protect switch to the unused switch pin (the one closest to the PWA). This gives write protect indication to the I/O and inhibits writing on a diskette with an unmasked slot.

11.2.12 Side 1 Select

Side 1 Select (J1-32) defines which side of a two-sided diskette is used for reading and writing.

A logic high selects side 0, the lower surface. A logic low selects side 1, the upper surface. When the selected diskette side is changed, a delay of 200 microseconds is required before any read or write operation is initiated (assuming that drive is selected, motor is on, and head is loaded).

11.2.13 In Use

In Use (J1-4) allows for the activation of the activity LED independent of Drive Select. When a logic low is applied to In Use the activity LED is turned on whether or not the drive is selected. In daisy-chain operation, all drives would have the activity LED illuminated if In Use is active.

12.0 CUSTOMER SELECTABLE OPTIONS

The 9409 contains a 14-pin program shunt module mounted on the PCB (Figure 23) which allows the drive to be selected to operate in a single drive system or a multiplexed drive system.

As shipped from the factory, each shunt position is shorted. Drive selection is accomplished by cutting selected shunt positions.

The program shunt module is AMP part number 435704-6. The shunt positions can be cut using an AMP cutting tool (part number 1-435830-1). The shunt is installed in a DIP socket and at the customer's option can be replaced by a DIP switch (AMP part number 435626-4).

Table 7 provides a listing of optional configurations which can be utilized by the customer.

12.1 MULTIPLEX OPTION

The 9409 is shipped from the factory configured to operate in a single drive system. To activate the multiplex option, cut the MX (5-10) position of the programmable shunt. This will allow the multiplexing of I/O lines. For single drive applications, shorting MX will cause a constant enable on the I/O signal lines whenever the drive is powered on.

		PC	SPEC. NO.	SHEET	REV.
		A	77653379	38	A

PRODUCT SPECIFICATION FOR THE 9409 FDD

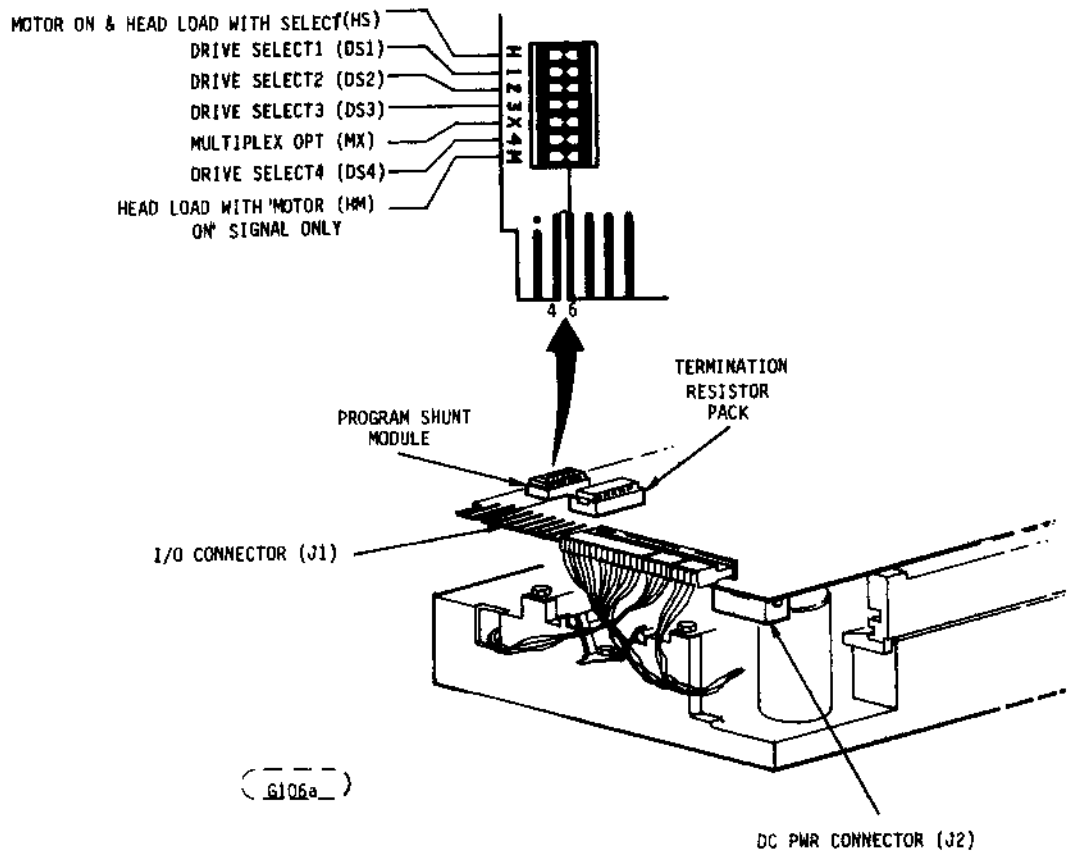

Figure 23. Program Shunt Module

12.2 DRIVE SELECT OPTIONS (1, 2, 3, 4)

The 9409 utilizes four input lines for designation of a particular drive. With MX (5-10) cut, positions DS1 through DS4 are used to select the Drive Select line which will activate the unique drive. Only the drive with its Drive Select line activated will respond to the input lines, gate the output lines, and turn on the indicator located on the front panel. (Exception: The In Use line will turn on the indicator independent of all other lines.) For example, in designating a drive as Drive 1, the user must cut Drive Select shunts DS2, DS3, DS4 (pins 3-12, 4-11, and 6-9, respectively) and leave DS1 (pins 2-13) shorted. Refer to Figure 24 for Drive Select shunt configurations.

		PC A	SPEC. NO. 77643379	SHEET 39	REV. A
--	--	---------	-----------------------	-------------	-----------

PRODUCT SPECIFICATION FOR THE 9409 FDD

12.3 HEAD LOAD WITH MOTOR ON

With HM (7-8) shorted and HS (1-14) open*, the read/write head will load against the media when the Motor On line is activated to a logic low.

12.4 HEAD LOAD WITH DRIVE SELECT

With HS (1-4) shorted and HM (7-8) open* the head load solenoid will energize with Drive Select activated and load the read/write head.

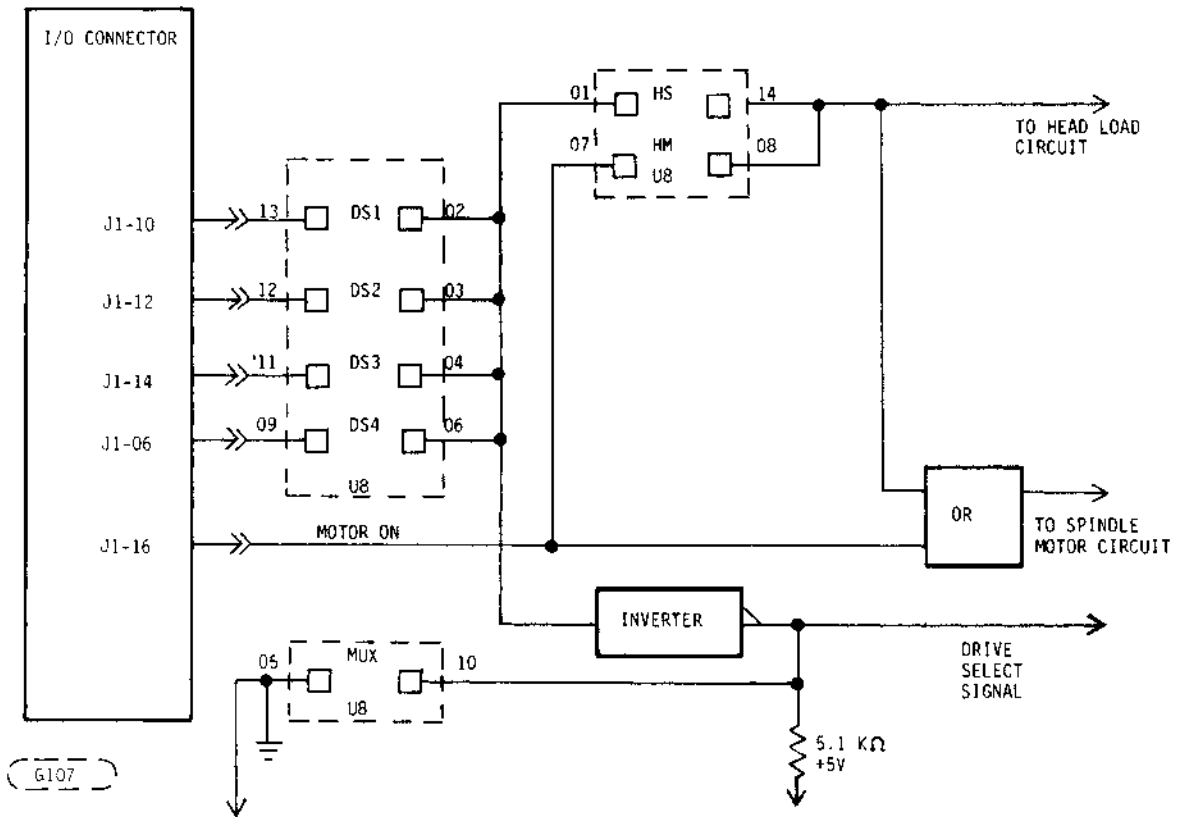

Figure 24. Drive Select Shunt Configuration

* It is an invalid configuration to have both HS (1-14) and HM (7-8) shorted. In such a configuration, input current to Motor On and/or Drive Select may damage drivers on the host.

