



**CONTROL DATA®
FLEXIBLE DISK DRIVE
MODEL 9404-B**

**GENERAL DESCRIPTION
OPERATION
INSTALLATION AND CHECKOUT
THEORY OF OPERATION
DIAGRAMS
MAINTENANCE
WIRE LISTS
PARTS DATA**

MAGNETIC PERIPHERALS INC.

 a subsidiary of
CONTROL DATA CORPORATION

HARDWARE MAINTENANCE MANUAL

REVISION RECORD															
REV	DATE	TABLE OF CONTENTS SHEETS AFFECTED	MANUAL/SECTION REVISION STATUS												CHANGE AUTHORITY
			1	2	3	4	5	6	7	8	9	10	11	12	
A	79 JUN 8		A	A	A	A	A	A	A	A	K			JAM	
B	79 Sept 24 PF		B	B	B	B	B	B	B	B	K			PL 21188 A	
C	79 Dec 13 PF	ii and vii	B	B	B	B	B	B	B	B	L			PL 21210	
D	79 JUN 11	ii	B	B	B	D	D	D	B	L				PL 21228	
E	80 MAY 20	ii, iv, viii, vi	B	B	E	E	E	E	B	M				PL 21239	
F	80 DEC 9 S.W.	ii, iii, v	B	B	E	E	E	E	B	M				PL 21262	
G	81 MAY 20 S.W.	ii	B	B	E	E	G	E	B	N				PL 21289	
H	82 MAY 10	ii	B	B	E	E	G	H	B	N				PL 21333	

Address comments concerning this manual to:

Technical Publications
Magnetic Peripherals Inc.

or use the enclosed user comment sheet.

Copyright 1979, 1980, 1981
Magnetic Peripherals Inc.

Printed in the United States of America
All Rights Reserved

PREFACE

This manual provides the information needed to install, operate and maintain the Control Data Corporation Model 9404B Flexible Disk Drive (FDD) and is intended to support customer engineers who require detailed information about the Flexible Disk Drive's operation.

The total content of the manual is comprised of two publications, each having a unique publication number, and is contained in one volume. The Manual's publication number (75897465) is that of the front matter, Sections 1 (one) through 7 (seven). This number should be used when making reference to the 9404B Flexible Disk Drive Hardware Maintenance Manual. Section 8 (eight), Parts Data, is identified by the unique publication number 77834771.

A configurator sheet is provided on the following page which describes FDD configurations supported by this manual. Refer to the equipment nameplate located on the right-hand side of the unit (viewed from the front) to determine the appropriate Top Mechanical Assembly (TMA) and equipment (BR) identification numbers. Then use the Configurator sheet as a starting point to establish the maintenance level for the device.

EMI NOTICE

NOTICE: This equipment has been designed as a component to high standards of design and construction. The product, however, must depend on receiving adequate power and environment from its host equipment in order to obtain optimum operation and to comply with applicable industry and governmental regulations. Special attention must be given by the host manufacturers in the areas of safety, power distribution, grounding, shielding, audible noise control, and temperature regulation of the device to insure specified performance and compliance with all applicable regulations. This equipment is a component supplied without its final enclosure and therefore is not subject to standards imposed by FCC Rules for Electro-Magnetic Interference (EMI). Federal Docket 20780/FCC 80-148 Part 15.

FLEXIBLE DISK DRIVE CONFIGURATOR SHEET

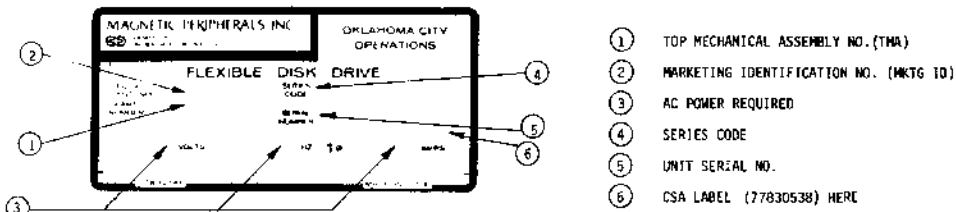

- ① TOP MECHANICAL ASSEMBLY NO. (TMA)
- ② MARKETING IDENTIFICATION NO. (MKTG ID)
- ③ AC POWER REQUIRED
- ④ SERIES CODE
- ⑤ UNIT SERIAL NO.
- ⑥ CSA LABEL (77830538) HERE

POWER REQUIREMENTS	WRITE PROTECT								
	TMA NO.	EQUIP. NO.	PWA NO.						
DC	15, 124 AT J7								
AC	230, 1Ø 50/60 HZ								
	120, 1Ø, 60 HZ								
	220, 1Ø, 50 HZ								
	75744080	BR8A5F	77643100	X		X			X
	75755081	BR8A5G	77643100			X			X
	75744083	BR8A5K	77643100	X	X				X
	75744084	BR8A5L	77643100		X				X
	75744087	BR8A5R	77644650	X		X			X
	75744088	BR8A5S	77644650	X			X		X

ZZ063b

TABLE OF CONTENTS

SECTION	PAGE
EMI NOTICE	iii
GENERAL DESCRIPTION	
1.1 INTRODUCTION	1-1
1.2 PURPOSE AND USE OF EQUIPMENT	1-1
1.3 PRODUCT DESCRIPTION	1-1
1.3.1 Physical Description	1-2
1.3.2 Electrical Description	1-2
1.3.3 Performance Characteristics	1-2
OPERATION	
2.1 INTRODUCTION	2-1
2.2 OPERATING INSTRUCTIONS	2-1
2.2.1 Flexible Diskette Loading	2-1
2.2.2 Flexible Diskette Removal	2-1
2.3 ERROR RECOVERY	2-1
2.3.1 Seek Error	2-1
2.3.2 Write Error	2-1
2.3.3 Read Error	2-2
2.4 DISKETTE HANDLING RECOMMENDATIONS	2-2
INSTALLATION AND CHECKOUT	
3.1 INTRODUCTION	3-1
3.2 UNPACKING	3-1
3.3 INSTALLATION	3-1
3.4 CABLING AND CONNECTIONS	3-1
3.4.1 INPUT-OUTPUT CABLE	3-1
3.4.2 DC POWER CONNECTION	3-2
3.4.3 AC POWER CONNECTION	3-2
3.5 ENVIRONMENT	3-2
3.6 INITIAL CHECKOUT	3-3
THEORY OF OPERATION	
4.1 INTRODUCTION	4-1
4.2 GENERAL DESCRIPTION	4-1
4.3 FUNCTIONAL DESCRIPTION	4-3
4.3.1 Control Logic	4-3
4.3.2 Write Logic	4-5
4.3.3 Read Logic	4-5
4.3.4 Customer-Installed Options	4-6
4.3.5 Disk Drive	4-7
4.3.6 Read/Write Head	4-7
4.4 Control and Data Line Characteristics	4-7
4.4.1 Logic Levels	4-7
4.4.2 Transmitter Characteristics	4-7
4.4.3 Line Receiver Characteristics	4-7
4.4.4 Control and Data Line Functions	4-7

SECTION

PAGE

DIAGRAMS AND MAINTENANCE AIDS

5.1	DIAGRAMS	5-1
5.2	MAINTENANCE AIDS	5-1
5.2.1	Introduction	5-1
5.2.2	Physical Description (Logic)	5-1
5.2.3	Use of Relative Level Indicators	5-1
5.2.4	Integrated Circuits	5-1

MAINTENANCE

6.1	INTRODUCTION	6-1
6.2	MAINTENANCE TOOLS	6-1
6.3	PREVENTIVE MAINTENANCE	6-1
6.4	HEAD CLEANING	6-1
6.5	TROUBLESHOOTING	6-2
6.5.1	DC Voltage and Signal	6-2
6.6	ADJUSTMENT PROCEDURES	6-4
6.6.1	Carriage-Stop Adjustment	6-4
6.6.2	Burst To Index Check and Adjustment	6-4
6.6.3	Actuator Alignment (Diskette)	6-7
6.6.4	Push-Rod Travel Adjustment	6-8
6.6.5	Door-Interlock Switch Adjustment	6-9
6.6.6	Disk-Load Bail Adjustment	6-10
6.6.7	Spindle and Cone Adjustment	6-11
6.6.8	Write Protect Assembly Adjustment (Where Applicable) ...	6-12
6.6.9	Track '00' Switch Adjustment	6-12
6.7	REMOVAL AND REPLACEMENT PROCEDURES	6-12
6.7.1	Printed Circuit Board (PWA)	6-13
6.7.2	Actuator Assembly	6-13
6.7.3	Drive-Motor Assembly	6-15
6.7.4	Head-Load-Pad Replacement	6-15
6.7.5	Solenoid Replacement and Tang Adjustment	6-15
6.7.6	Carriage and/or Stepper Motor Replacement	6-17
6.8	FREQUENCY CONVERSION	6-18
6.8.1	Operating Frequencies Conversion Procedure	6-18

WIRE LISTS

7.1	INTRODUCTION	7-1
7.2	UPPER HARNESS ASSEMBLIES	7-1
7.3	LOWER HARNESS ASSEMBLY	7-1
7.4	STEPPER MOTOR	7-1
7.5	WRITE PROTECT	7-1

SECTION	PAGE
PARTS DATA	
8.1 INTRODUCTION	8-1
8.2 ILLUSTRATIONS	8-1
8.3 PARTS LISTS	8-1
8.4 TOP MECHANICAL AND ASSEMBLY LOCATION	8-1
8.4.1 Top Mechanical Assembly (TMA)	8-1
8.5 REPLACEMENT PARTS	8-1
8.6 PARTS LIST INSTRUCTIONS	8-12
8.6.1 Illustration Parts Lists	8-12
8.6.2 Top-Down Assembly/Component Parts Lists	8-12
8.6.3 Cross Reference Index	8-12
8.6.4 Sheet Number Referencing	8-12

LIST OF ILLUSTRATIONS

FIGURE NO.	TITLE	PAGE
2-1	Diskette Installation	2-2
4-1	Functional Block Diagram	4-2
5-1	Timing	5-2
5-2	Schematic	5-3
5-3A	Assembly and Parts List (PWA 77643100)	5-5
5-3B	Assembly and Parts List (PWA 77644650)	5-5.1
5-4	J1 and J7 Pin Assignments	5-6
6-1	Head Load and Door Interlock Switch	6-2
6-2	Differential Read Signal for Entire Track	6-3
6-3	Differential Read Signal For Portion of Outer Track	6-3
6-4	Write Data and Head Write Voltage For Outer Track	6-3
6-5	Base and Chassis Support Assembly	6-5
6-6	Carriage-Stop Adjustment	6-6
6-7	Write Splice Bit To Index Timing	6-6
6-8	Head Alignment Amplitude	6-8
6-9	Chassis Base Assembly	6-9
6-10	Disk Load Solenoid	6-10
6-11	Spindle and Cone	6-11
6-12	Base Casting Assembly	6-14
6-13	Head-Load-Pad Replacement Illustration	6-16
6-14	Solenoid Adjustment	6-17
6-15	Drive Pulley Reversal	6-18

LIST OF TABLES

TABLE NO.	TITLE	PAGE
4-1	Phase Sequence of Stepper Motor	4-4
4-2	Input/Output Lines	4-8

1.1 INTRODUCTION

The Model 9404B single-sided LSI Flexible Disk Drive (FDD) is a compact, random access, data storage device that interfaces with a central processor via a control unit. Input/output data and control signals are transmitted by means of an I/O cable.

1.2 PURPOSE AND USE OF EQUIPMENT

Data, in the form of magnetized bits, is written on, or read from the tracks of a rotating diskette. The FDD uses a single, flexible, removable diskette (one recording surface) enclosed in a sealed jacket. The unit is capable of 32 hard-sector or soft-sector format operation.

1.3 PRODUCT DESCRIPTION

The major FDD components are the spindle, disk drive motor, read/write head, stepping motor, track-indexing device, and printed-circuit board.

A write-protect option is offered.

All FDD components are mounted on a base assembly. The front panel has a spring-loaded door through which the diskette is installed. The door is mechanically linked to the disk loading mechanism and the head-load interlock switch; therefore, when the door is closed the Read/Write head may be loaded on the diskette in preparation for the transfer of data.

Star- versus Daisy-Chain-Connected Configurations - Throughout this manual certain features and operations of the Flexible Disk Drive are described in terms of the manner in which the FDD is configured for connection to its controller, either star or daisy chain.

Star-configured devices are designed to be connected to their associated controller in "star" fashion wherein each FDD unit has its own complete umbilical cable connection to the controller, with no interconnection between FDD units.

Daisy-chain-configured devices allow one to four FDD units to be connected serially to a common controller. The controller monitors the operational readiness of any selected FDD in its chain and commands and controls the reading and writing operation.

1.3.1 PHYSICAL DESCRIPTION

The physical dimensions for the equipment are as follows:

Height	4.97 in. (126.2 mm)
Width	8.78 in. (223.0 mm)
Depth	14.24 in. (361.7 mm)
Weight	12 lbs. (5.44 kgm)

1.3.2 ELECTRICAL DESCRIPTION

The electrical specifications for the equipment are as follows:

- DC Power Source (Supplied by Host Equipment)
 - +24 Volts ($\pm 10\%$) @ 1.3 A Typical
 - +5 Volts ($\pm 5\%$) @ 0.7 A Typical
- AC Power Source - Refer to the FDD configurator or nameplate to determine AC Power requirements.

1.3.3 PERFORMANCE CHARACTERISTICS

The equipment specifications for the FDD are as follows:

- ACCESSING TIME

Maximum Access Time	775 ms
Maximum One-Track Access Time	25 ms
Average Access Time	268 ms

- RECORDING

Mode	Double Frequency	MFM
Density (nominal)	1836 BPI (72.3 BPmm)	3672 BPI (144.6 BPmm) Outer Track
	3268 BPI (128.7 BPmm)	6536 BPI (257.3 BPmm) Inner Track

Data Transfer Rate	249,984 bits/sec	499,968 bits/sec
Bits/Byte	8	8
Bits/Track	41,664	83,328
Tracks	77	77
Sectors	Format Determined	Format Determined

- DATA CAPACITY

Bytes/Track	5,208	10,416
Bits/Track	41,664	83,328
Bits/Diskette	3,208,128	6,416,256

- FLEXIBLE DISKETTE
 - CDC 421 Single Density, or Equiv.
 - CDC 423 Double Density, or Equiv.
 - Diskette Dimensions 8 x 8 inches (203.2 x 203.2 mm)
(including jacket)
 - Usable Diskette Recording Surfaces 1
 - Diskette Surface Diameter 7.88 in. (200.2 mm)
 - Recording Radii Track 76 (inner) 2.0290 in. (51.5 mm) nominal
Track 00 (outer) 3.6123 in. (91.8 mm) nominal
 - Diskette Surface Coating Magnetic Oxide
 - Diskette Velocity 360 r/min
- READ/WRITE HEAD
 - Head Unit 1
 - Track Width 0.013 in. (0.33 mm)
 - Track Spacing 0.02083 in. (0.529 mm)
 - Erase to Read/Write Gap 0.035 in. (0.889 mm)

2.1 INTRODUCTION

The FDD is under direct control of the input/output and power sources. No special start-up procedure is required. Operation is fully automatic and requires no normal operator intervention.

2.2 OPERATING INSTRUCTIONS

Verify that power and I/O cables are securely attached before operation.

2.2.1 FLEXIBLE DISKETTE LOADING

- a. Open FDD door.
- b. Apply AC/DC power to unit.
- c. Remove diskette from storage envelope.
- d. On units with the Write-Protect option, be sure the Write-Protect slot in the jacket is open, as shown in Figure 2-1, if the diskette is to be write-protected.
- e. If a diskette with a Write-Protect slot is not utilizing Write Protect (that is, it will be written on), the slot must be covered with a piece of tape which is opaque to infrared when used in an FDD with the Write Protect option.
- f. Carefully slide diskette into FDD, as shown in Figure 2-1, until jacket is solidly against stops.
- g. Carefully close unit door. Ensure that jacket is properly seated, spindle has engaged diskette, and door is closed and latched.
- h. Protect the empty envelope from liquids, dust, and metallic materials.

2.2.2 FLEXIBLE DISKETTE REMOVAL

- a. Open FDD door to stop diskette rotation and disengage spindle.
- b. Remove diskette from FDD and put it in its storage envelope.
- c. Close FDD door.

2.3 ERROR RECOVERY

The following paragraphs give information needed to recover from possible errors in equipment operation.

2.3.1 SEEK ERROR

Seek errors will rarely occur unless the stepping rate is significantly exceeded. In the event of a seek error, recalibration of track location can be achieved by repetitive Step Out commands until a Track 00 signal is received.

2.3.2 WRITE ERROR

To guard against degradation from imperfections in the media, no more than four attempts to write a record should be used when Read After Write errors are encountered. In the event a record cannot be successfully written within four attempts, it is recommended that the sector or track be labeled defective and an alternate sector or track assigned. If more than two defective tracks are encountered, it is recommended that the diskette be replaced.

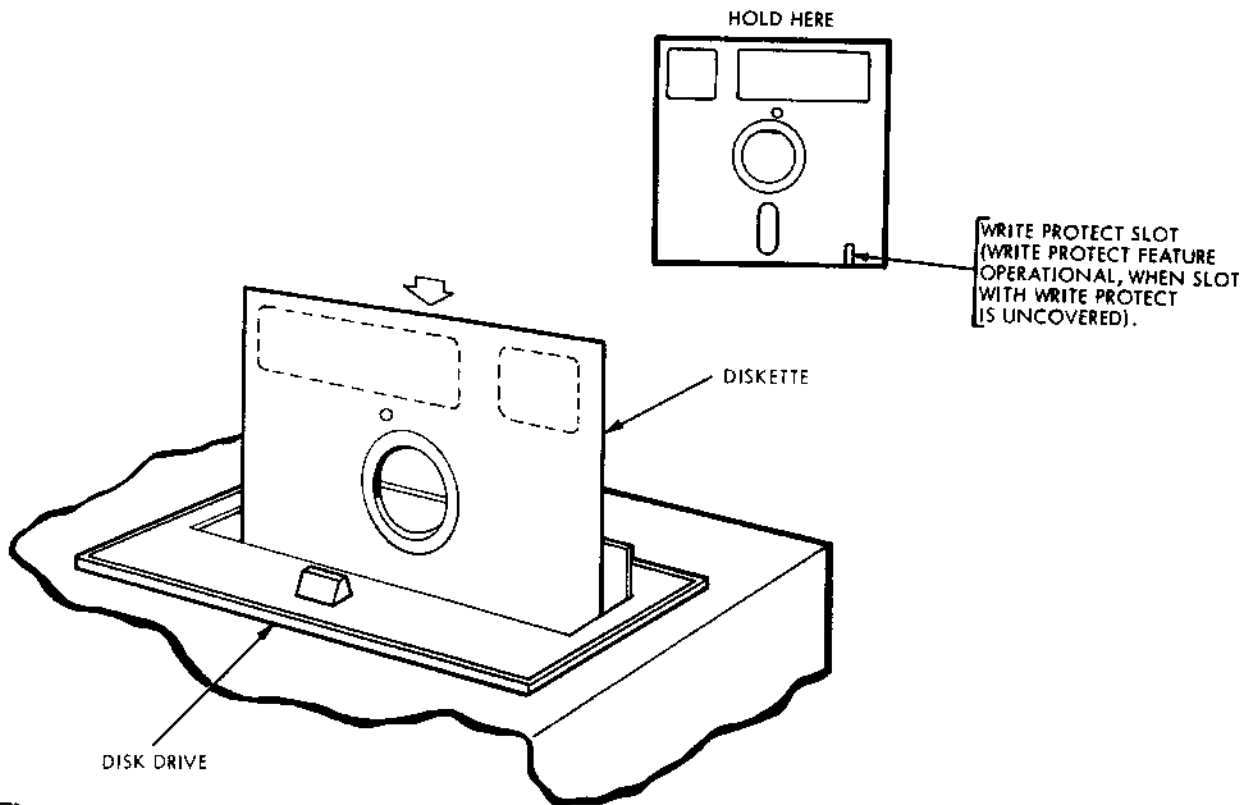

88093

FIGURE 2-1. DISKETTE INSTALLATION

2.3.3 READ ERROR

In the event of a Read error, up to 10 attempts should be made to recover with re-reads. If after 10 attempts the data has not been recovered, step the head several tracks away and then reposition to recover the data. Unloading the head when data transfers are not imminent will increase the data reliability and extend the diskette life.

2.4 DISKETTE HANDLING RECOMMENDATIONS

Since the recorded diskette contains vital information, reasonable care should be exercised in its handling. Longer diskette life and trouble free operation will result if the following recommendations are followed.

- a. Do not use a writing device which deposits flakes, e.g., lead or grease pencils, when writing on diskette jacket label.
- b. Do not fasten paper clips to diskette jacket edges.
- c. Do not touch diskette surface exposed by jacket slot.
- d. Do not clean diskette in any manner.
- e. Keep diskette away from magnetic fields and from ferromagnetic materials that may be magnetized.

- f. Return diskette to envelope when removed from FDD.
- g. Protect diskette from liquids, dust, and metallic substances at all times.
- h. Do not exceed the following storage environmental conditions:

Temperature: 50° to 125°F (10° to 51.7°C)
Relative Humidity: 8% to 80%
Maximum Wet Bulb: 85°F (29.4°C)

- i. Diskettes should be stored in a box or cabinet when not in use.
- j. Remove diskette before applying or removing power to the FDD.

3.1 INTRODUCTION

This section provides the information and procedures necessary to put an FDD into operation.

3.2 UNPACKING

Unpack FDD as follows:

- a. Cut banding and lift top half of styrofoam shell from unit.
- b. Lift unit in polyethylene bag from bottom half of styrofoam shell and remove unit from polyethylene bag.

During unpacking, care must be used so that any tools being used do not inflict damage to the unit. As a unit is unpacked, inspect it for possible shipping damage. All claims for this type of damage should be filed promptly with the carrier involved. If a claim is filed for damages, save the original packing materials.

3.3 INSTALLATION

Install the FDD in the designated location in the host equipment.

3.4 CABLING AND CONNECTIONS

Connect the AC cable, I/O cable, and DC cable between the FDD and host equipment.

3.4.1 INPUT-OUTPUT CABLE

The maximum cable length from connector to connector is 25 feet. All inputs and outputs require pairs, one line for function, one for ground. The characteristic impedance is typically 120 ohms.

The information relative to the I/O connector (J1) and pin/signal assignments are defined in Figures 5-2 and 5-4.

The following mating connectors are recommended:

<u>TYPE OF CABLE</u>	<u>MANUFACTURER</u>	<u>CONN. P/N</u>	<u>CONTACT P/N</u>
Twisted Pair, #26 (crimp or solder)	AMP	1-583717-1	583616-5 (crimp) 583854-3 (solder)
Twisted Pair #26 (solder term.)	VIKING	3VH25/1JN-5	NA
Flat Cable	3M "Scotchflex"	3415-0001	NA

On models configured for daisy-chain operation, the terminating resistor module RM1 (see Figure 5-3) is installed in the end FDD (farthest from the controller) **ONLY**. Terminators in more than one FDD during daisy-chain hookup may result in damage to the controller. For multiple-drive daisy-chain operation, the resistor modules of all but the end unit must be removed. The addresses of additional FDD's are established by moving W1 to the W2 position for Unit 2 address, to W3 for Unit 3 address, and to W4 for Unit 4 address on 77643100 PWA's and by punching out all but the desired shunt which corresponds to the drives' addresses (refer to Figure 5-3B) on 77644650 PWA's. For unit 1 leave shunt 1, for unit 2 leave shunt 2, etc.

3.4.2 DC POWER CONNECTION

DC power (user-supplied) comes through a stranded wire, 18 AWG minimum cable which interfaces with its mating connector on the printed-circuit board. The pin assignments are on Sheet 1 of the schematic, Figure 5-2, and on Figure 5-4. Mating connectors:

For J7 on 77643100 and 77644650 PWA's

<u>MANUFACTURER</u>	<u>CONN. P/N</u>	<u>CONTRACT P/N</u>
AMP	583873-1	583649-6 (Crimp) 583854-3 (Solder)
VIKING	3VH6/ICN-12	NA

For J10 on 77644650 PWA's only

<u>MANUFACTURER</u>	<u>CONNECTOR P/N</u>	<u>CONTRACT P/N</u>
AMP	1-480270-0	60619-1

3.4.3 AC POWER CONNECTION

The AC Power Cable consists of stranded wire, 18 AWG minimum with center pin connection utilized as frame ground. Mating connector:

PLUG:

AMP PN 1-480700-0

CONTACTS: (SOCKET)

AMP PN 350536-1 (STRIP)

AMP PN 350550-1 (LOOSE)

3.5 ENVIRONMENT

Operating and storage environments of the FDD are as follows:

Operating: 55° to 100°F (12.8° to 37.8°C) 12°F (6.7°C)/hr max. fluctuation
20% to 80% relative humidity
(providing there is no condensation).

Non-Operating: -30° to +150°F (-34.4° to 65.6°C)
5% to 95% relative humidity
(providing there is no condensation)
Max. Wet Bulb 80°F (26.7°C).

3.6 INITIAL CHECKOUT

This procedure should be used to determine that the FDD is operational. The procedure assumes that the unit is installed and the I/O and power cables are connected.

- a. Apply AC power to unit and visually check that the spindle rotates.
- b. Apply DC power to unit.
- c. Insert diskette as described in Section 2.
- d. Apply a head-load-command signal to the unit and close the access door. Check that the door microswitch is actuated, and the head-load solenoid actuates.
- e. Apply a stepping-command signal to the unit and check that the actuator steps the head as commanded.
- f. Remove diskette.
- g. Remove the command signals and power from the unit.

4.1 INTRODUCTION

The basic functions performed by the FDD are: (1) Receive and generate control signals; (2) Position the Read/Write head on selected tracks; and (3) Write or Read data upon command from the FDD controller. These functions are accomplished upon selection of the unit and after initial indication to the controller that the FDD is ready to operate and accept commands.

The Theory of Operation for the FDD is divided into two parts. The first part gives a general theory of operation. The second part gives a detailed functional description of all major components both electronic and mechanical and describes all signals exchanged between the FDD and the controller.

4.2 GENERAL DESCRIPTION

The basic function of the FDD is to indicate to the controller when it is ready to operate and respond to the commands of the controller to: (1) Receive and generate control signals; (2) Position the Read/Write head to selected tracks; and (3) Write or Read data on the diskette when selected. The Write-Protect function described may not apply to your particular FDD model. (Refer to the Preface at the front of the manual.)

Signals received and transmitted by the FDD are shown in Figure 4-1, and explained in Table 4-2. All signals received by the FDD are gated with Unit Select so that no stepping, reading, or writing can be performed on an unselected FDD. All signals generated within the FDD are gated with Unit Select so that no signals can be transmitted from an unselected FDD.

During the write operation, the selected FDD receives Write Enable, Head Load, Write Data, and Low Current (Track 43 or greater) signals. During the read operation, the selected FDD will receive a Head Load command. The Write Enable line remaining high implies a read operation. Under these conditions, the FDD will transmit the Composite Read Data signal to the controller. Controller Step commands are received initiating a Track Seek operation on a selected FDD. The FDD transmits Index and Sector pulses as long as it is selected. Also, the selected FDD transmits a Track 00 signal to the controller whenever the Read/Write head is at Track 00.

Positioning of the carriage-mounted Read/Write head is accomplished by a lead screw driven by a stepper motor. Each step command from the user system increments the stepper motor which, in turn, rotates the lead screw 15 degrees. Each 15 degree rotation of the lead screw moves the Read/Write head one track position.

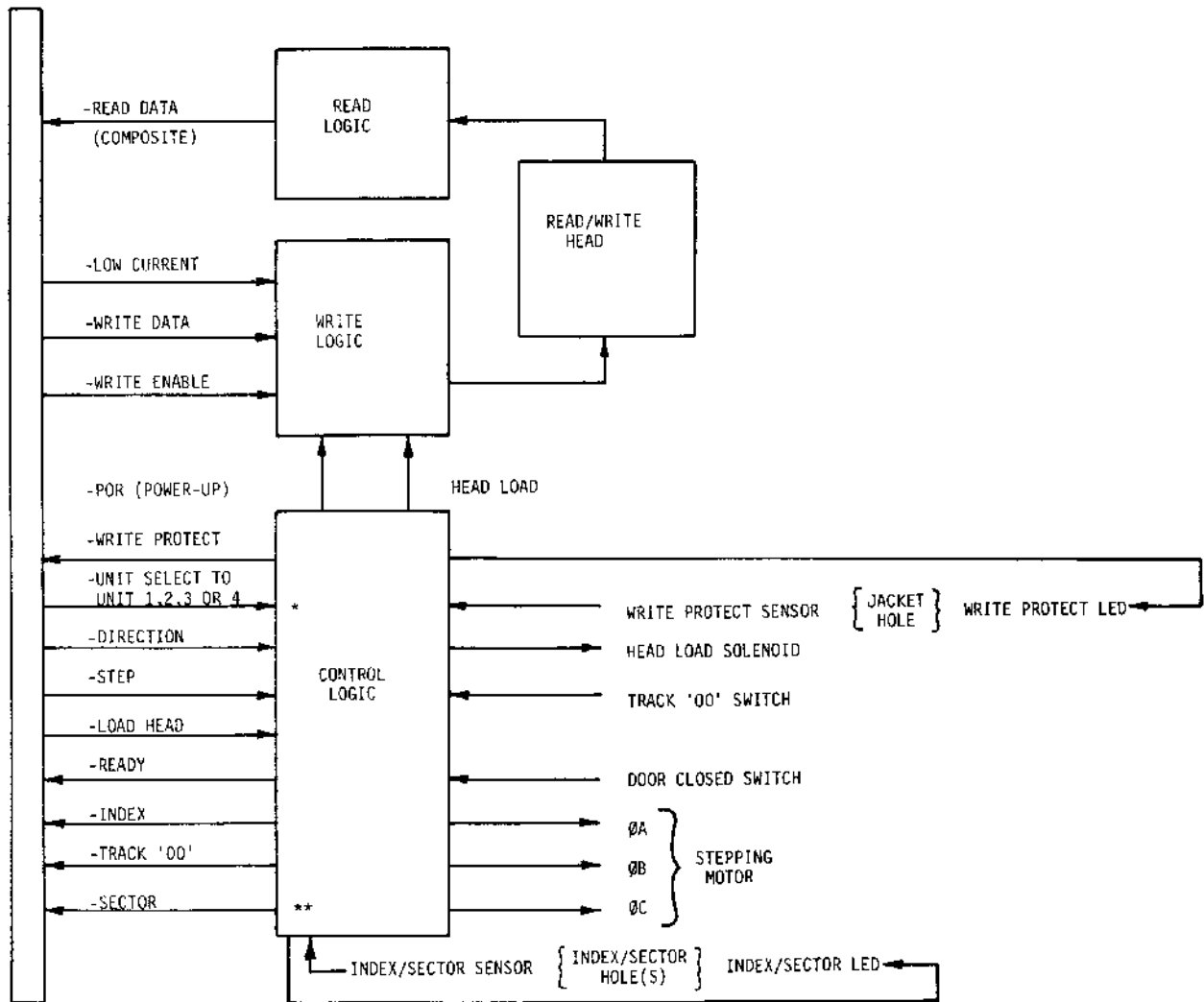

Z2656
 * DAISY-CHAIN CONFIGURATION ONLY
 ** OPTION

FIGURE 4-1. FUNCTIONAL BLOCK DIAGRAM

A reading or writing operation begins by placing the Read/Write head in contact with the diskette with a Head-Load command and at the desired track. To write on the diskette, Write Enable is sent by the controller to condition the write logic. The write current then in the head, reverses polarity synchronous with the low-to-high transitions of the Write Data pulses from the controller. The current reversals cause magnetic flux reversals, the data and clock bits which are induced on the desired diskette track. Erasure of previously recorded data is simultaneously accomplished during the writing operation in addition to a delayed-tunnel-erase which ensures diskette interchangeability.

To read from the diskette, magnetized bits in the format of the prerecorded data are sensed by the Read/Write head. This signal is amplified, digitized, and transmitted to the user system as composite clock and data information.

The FDD utilizes an LSI control chip fabricated from "current-injection logic" (I²L) technology. The LSI circuit contains an internal oscillator-generated clock. This synchronous logic design controls all timing functions. Another LSI (read) chip performs the analog-to-digital conversion within the device.

4.3 FUNCTIONAL DESCRIPTION

Refer to Figures 4-1, 5-1, and the Schematic Diagram, Figure 5-2, for the following discussion.

The FDD is divided into the following major functional areas:

- a. Control Logic
- b. Write Logic
- c. Read Logic
- d. Disk Drive
- e. Read/Write Head

4.3.1 CONTROL LOGIC

The functions of the control logic are to generate the signals that (a) establish the ready status of the FDD, (b) step the Read/Write head in or out upon selection and command of the controller, (c) load the head on the disk for read/write operations, (d) protect the disk from writing if the write-protect slot is present, (e) indicate when the Read/Write head is at Track 00, (f) generate the Index and Sector pulses when the diskette is rotating and the FDD is selected, and (g) provide unit selection of the FDD.

- a. The Ready signal is generated when the diskette comes up to proper operating speed. The Index pulses are used to determine operating speed within LSI control chip U4. The Ready signal is present only when the FDD is selected.
- b. At initial voltage application, ϕA of the stepper motor is energized. Each step command received sequentially energizes one of the three phases of the stepper motor. Either the logic level of the direction signal or the use of Step In or Step Out signals determines whether the phase sequence is ϕA , ϕB , ϕC , ϕAor ϕA , ϕC , ϕB , and ϕA .

Movement of the Read/Write head is initiated by the step commands from the controller. The head is stepped one track, either toward the spindle (In) or away from the spindle (Out), with each step command. The direction is regulated by the status of the Direction line (a low level of the Direction line conditions the Read/Write head to step toward the spindle, and a high level conditions the Read/Write head to step away from the spindle).

Drive to the specific stepper-motor phases, ϕ_A , ϕ_B , and ϕ_C , is provided by logic-driven Darlington transistors Q1, Q2, and Q3.

The phase sequence through which the stepper motor is driven (see Table 4-1) is controlled by U4 pins 30, 31, and 32. During a phase change, the previously active phase from U4 remains on (or overlaps) 4.5 ms after the next (or new) phase is activated. Refer to Figure 5-1.

TABLE 4-1. PHASE SEQUENCE OF STEPPER MOTOR

Change the Active Phase ϕ		To Step
From	To	
A	B	IN
B	C	
C	A	
A	C	OUT
B	A	
C	B	

- c. The Read/Write head of a selected FDD can be loaded when the diskette is fully installed and the front panel door is closed. Closing the front-panel door actuates the door-interlock switch which enables the circuit to the head-load solenoid. When the controller sends a Head Load signal, the head-load solenoid is energized causing the armature bail to actuate. The actuation of the bail permits the head-load arm and its pressure pad, under tension, to hold the diskette surface against the Read/Write head.
- d. The Write Protect function is accomplished through use of an LED (light-emitting diode) and a photo-transistor. These are mounted such that the presence of a write protect slot in the jacket of the diskette will cause pins 1 and 2 of gate U5 to be driven low. This signal is gated with Unit Select at the interface. Write Protect will inhibit writing on any diskette possessing a write-protect slot by shunting write current from the write-current injection pin (8) of U4.
- e. The Track 00 signal is generated when the carriage assembly closes the Track 00 switch. Closing this switch sets the latch formed by the two gates of U3 pin 3 and U3 pin 5. The output of this latch (pin 4) is gated with ϕ_A and Unit Select in U4 to provide the Track 00 signal that is transmitted to the controller from U4 pin 27.

- f. The beginning of each diskette track is indicated by an Index pulse. The diskette rotates between a light source (LED) and a sensor (photo transistor). When the index hole in the diskette passes over the light source, light is detected by the sensor. The sensor output is amplified and transmitted to the controller as the Index pulse when the FDD is selected.

An index/sector separator can be provided on the FDD for use with hard-sectored diskettes. Proper operation of the ready function requires that the index pulses be separated in the FDD. To activate the Index/Sector separator and provide for proper hard-sector operation, jumper W8 must be installed and the Burst-to-Index Adjustment (Section 6.6.2) must be performed.

- g. The unit select function inhibits all command and status signals. The position of the jumper W1, W2, W3, or W4 on 77643100 PWA's and by the shorted shunt position of the DIP shunt DS1 on 77644650 PWA's. The 77643100 PWA, as shipped, has W1 installed.

4.3.2 WRITE LOGIC

A write operation begins with a Write Enable command from the controller when the FDD is selected. This command simultaneously enables the write-data switching drivers within U4 (pins 9 and 10), turns on head center-tap drivers in U4 (pins 5 and 7) causing the center tap to go to approximately +12 volts, blocks the input to the read circuit by reverse-biasing diodes CR1 and CR2, and after a delay energizes the erase windings. Data applied to the Write Data input alternately switches a constant write current through the write drivers to the head windings. Low-current operation, used when writing on track 43 or greater, is selected by switching shunt resistor R28 into the write-current source. The source is contained within U4 and is factory-adjusted at R33.

4.3.3 READ LOGIC

Read operation is enabled when the Read/Write head is loaded on the diskette and Write Enable is inactive. With Write Enable inactive, the data-blocking diodes CR1 and CR2 are forward-biased by parallel 1K resistors in U4 (pins 5 and 7) pulling the head center tap to ground, and data sensed by the Read/Write head is fed to the LSI read-data circuit U2. The read signal from the diskette is in the form of a sine wave.

This analog signal is amplified within U2, filtered by R15, R16, L1, L2, C7, and C8 comprising a passive constant-phase filter, differentiated by R20 and C11 in conjunction with U2's active differentiator, and coupled to a comparator/logic circuit within U2 (a time-domain filter) to detect zero crossings and reject noise in the differentiated read signal. R8 and C4 are the timing components for a 1- μ s one-shot used in the time-domain filter. R9 and C5 are the timing components for the one-shot which establishes data pulse width. DC balance of the active differentiator by adjusting R32 allows symmetry of the read data to be optimized.

4.3.4 CUSTOMER-INSTALLED OPTIONS

The following options may be installed by the customer by soldering in or removing the specified jumper wires. Jumper wires are identified as WXX components in the schematics and the "W" identifiers are etched into the PWA artwork for easy identification.

UNIT SELECT

Jumper W1 is installed in the drive at the factory so that the unit is selected via J1-26 (-UNIT SELECT-1). The device address may be changed to allow for daisy-chain operation by removing W1 and installing W2, W3, or W4 which allow device selection via J1-28, J1-30, or J1-32, respectively.

Alternatively, jumper W5 may be installed to cause the device always to be selected. This feature can only be used in a star or radial configuration.

HEAD LOAD

The head-load function is normally controlled by the host controller via I/O input at J1-18. Jumper W15 can be installed to defeat this external head-load control. With W15 installed, the head will be loaded any time the device is selected and the front door is closed.

SEPARATED SECTOR

The 9404B FDD is configured at the factory to operate with soft-sector diskettes. To operate with 32-hole hard-sector diskettes, install W8. This causes the composite sector and index pulse signal at U4 pin 23 to be separated within U4 so that separated sector pulses are sent to the controller on J1-24 and index pulses are sent on J1-20. Also, the separated-sector-option jumper W8 is required for hard-sector-format operation to assure proper function of the ready logic.

STEP IN/STEP OUT

Installation of jumper W12 changes I/O input functions STEP and DIRECTION to STEP IN and STEP OUT as follows:

-STEP IN (J1-34) - A two-microsecond minimum, three-millisecond maximum logic 1 level pulse on this line causes the head to move one track inward toward the center of the diskette;

-STEP OUT (J1-36) - A two microsecond minimum, three millisecond maximum logic 1 level pulse on this line causes the head to move one track outward from the center of the diskette.

4.3.5 DISK DRIVE

Disk drive is accomplished by clamping the diskette between the cone assembly and a belt-driven spindle. The spindle is rotated at 360 r/min by the disk-drive motor.

4.3.6 READ/WRITE HEAD

The Read/Write head is in direct contact with the diskette during read or write operation. Since the head is rigidly mounted on the carriage assembly, head load is achieved by a solenoid-actuated bail allowing the head-load arm to force the diskette against the Read/Write head. The head surface is designed for maximum signal transfer to and from the magnetic surface of the diskette with minimum head/diskette wear. The tunnel-erase gap DC-erases the intertrack area to improve off-track signal-to-noise ratio and permit diskette interchange between units.

4.4 CONTROL AND DATA LINE CHARACTERISTICS

All signal lines must be terminated at the receiver with a characteristic impedance of 120 ohms, typically. Transmission is by 26 AWG (min.), 120-ohm flat cable or twisted pair (one twist per inch) with a maximum line length of 25 feet. Figure 5-1 shows the timing of typical operations.

4.4.1 LOGIC LEVELS

The following definitions will be used throughout this manual:

low = Logic 1, Active State Refers to the low-voltage condition
+0.4 VDC Max.

high = Logic 0, Inactive State Refers to the high-voltage condition
+2.4 VDC Min.

4.4.2 TRANSMITTER CHARACTERISTICS

The FDD uses the TTL7438 (quad 2-input buffer or driver) and LSI controller U4 to transmit all control and data signals. Each is capable of sinking a current of 25 mA with an output voltage of 0.4 volt.

4.4.3 LINE RECEIVER CHARACTERISTICS

The FDD uses the SN7400 family gates and their equivalent in the LSI controller IC U4 for line receivers. The input of each receiver is terminated in 120 ohms.

4.4.4 CONTROL AND DATA LINE FUNCTIONS

The signals that are exchanged are described in Table 4-2 and are shown relative to a point of origin in Figure 4-1.

TABLE 4-2. INPUT/OUTPUT LINES

SIGNAL	FUNCTION
<u>INPUT LINES</u>	
-STEP	<p>A two-microsecond minimum, three-millisecond maximum logic 1 level pulse on this line causes the head to move one track as determined by the direction line.</p>
-DIRECTION	<p>A logic 1 level on this line and step pulse causes the head to move one track inward toward the center of the diskette. A logic 0 level on this line and step pulse causes the head to move one track outward from the center of the diskette.</p>
-HEAD LOAD	<p>A logic 1 level on this line loads the diskette against the head through the use of a pressure pad on the opposing side of the diskette. The logic 1 level must be initiated 60 milliseconds prior to initiating a read or write operation to allow for head load settling time.</p> <p>For increased head and media life, this signal should be at a logic 0 whenever a data transfer operation is not in process or pending.</p>
-WRITE ENABLE	<p>To enable the FDD write driver, this line is held at a logic 1.</p> <p>To disable the FDD write driver and enable the FDD read circuitry, this line is held at logic 0. 850 microseconds minimum is required after a write operation before read data is stable.</p>

TABLE 4-2. INPUT/OUTPUT LINES (CONT'D)

SIGNAL	FUNCTION
<u>INPUT LINES</u>	
-WRITE DATA	This line contains the composite double frequency coded write clock and data information to the FDD. The write clock and data pulses must be 250 nanoseconds $\pm 20\%$ in length and are true at the logic 1 level. Information to be recorded on the diskette is derived from the transition of each pulse from logic 1 to logic 0.
-LOW CURRENT	This line reduces write current for tracks 43 or greater. A logic 1 level reduces write current.
-UNIT SELECT	On this line a logic 1 level with W1, W2, W3, or W4 present enables the FDD interface.
<u>OUTPUT LINES</u>	
-READY	A logic 1 level indicates that the door is closed, a diskette is rotating, and that the FDD is selected.
-INDEX	This line gives an indication of the rotational position of the diskette by outputting a logic 1 pulse for every index hole of the diskette. The 1-millisecond pulse is generated by sensing the index hole in the diskette using a photo-optical technique.
-SECTOR* (OPTION)	This line gives an indication of the rotational position of the hard-sector diskette by outputting a logic 1 pulse for every sector hole of the diskette. The 1-millisecond pulse is generated by sensing the sector holes with the same photo-optical assembly used for index. (W8 must be present.)
-TRACK 00	A logic 1 level indicates that the head is positioned over Track 00.
-WRITE PROTECT	Logic 1 level indicates that the Write-Protect slot on diskette is uncovered on models which have the Write Protect feature.
-READ DATA COMPOSITE	This line contains the unseparated data and clock information. A logic 1 level pulse of 250 ns corresponds to a data or clock bit read from the diskette.

*The hard-sector option is not active as the FDD is supplied from the factory. To provide for hard-sector operation, it is necessary to install jumper W8 and perform the Burst-to-Index Adjustment in Section 6.6.2.

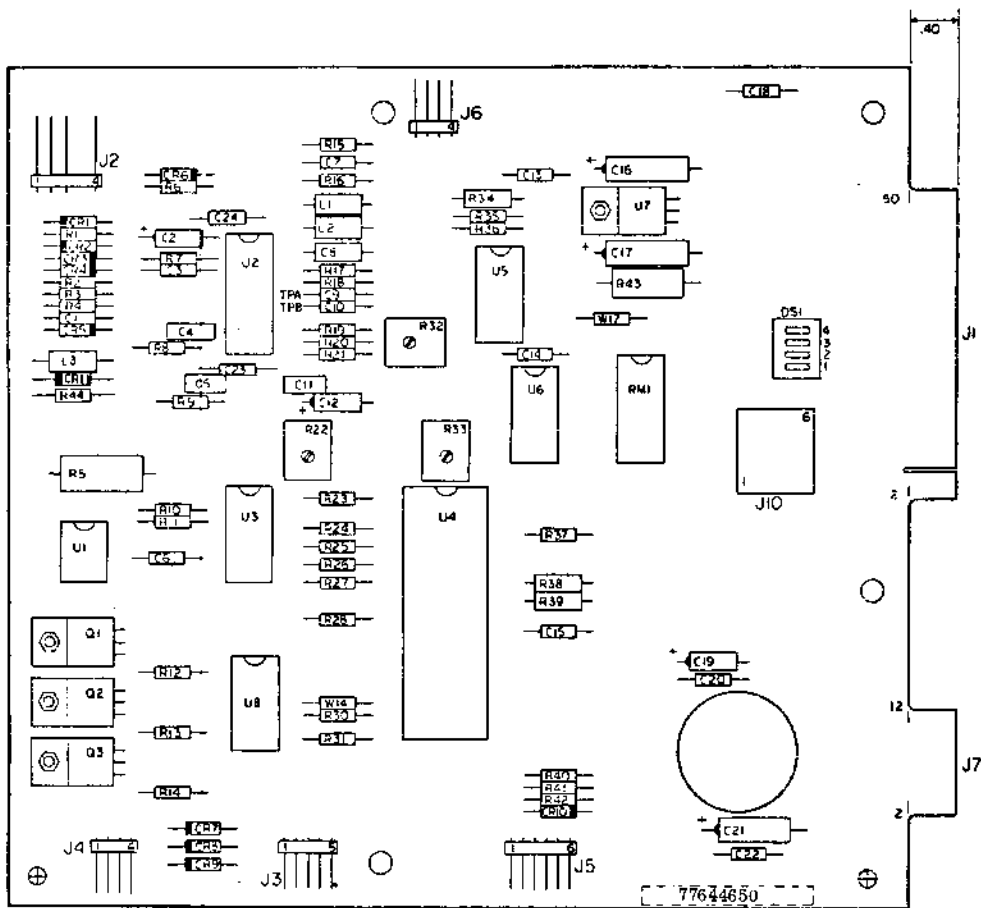

TRANSISTORS	DIODES
Q1, Q2, Q3 - TIP120	CR1, CR2, CR3 } IN914A
	CR4, CR5 } IN914A
	CR6, CR7, CR8 } IN4001
	CR9, CR10, CR11 } IN4001

FIGURE 5-3B. ASSEMBLY AND PARTS LIST
(PWA 77644650)

(DS-1-DIP SHUNT - AMP 435704-4 - shipped with all positions shorted. To select address punch out all shunts except one corresponding to the desired address.)

5.1 DIAGRAMS

This section contains the printed circuit board documentation and related timing diagrams.

Figure 5-1 shows timing diagrams which illustrate signal/time relationships during read, write, step-in, and step-out operations. Figure 5-2 is the printed circuit board schematic, Figure 5-3 contains the assembly drawing, and Figure 5-4 contains J1 and J7 Pin assignments.

5.2 MAINTENANCE AIDS

5.2.1 INTRODUCTION

This section contains detailed information on the logic circuits used in the FDD. The logic consists of two types of circuits: discrete component and integrated circuits (IC). Integrated circuits are contained within a single chip and discrete component circuits contain individually identifiable resistors, capacitors, transistors, etc.

5.2.2 PHYSICAL DESCRIPTION (LOGIC)

All components are mounted on one side of the printed circuit board. The board is 7 in. X 8 in. (177.8 mm X 203.2 mm) and contains both IC and discrete component circuits.

5.2.3 USE OF RELATIVE LEVEL INDICATORS

The relative level indicator is a small triangle located on the input or output to a logic block. The relative level indicator depicts the occurrence of inversion. The presence or absence of this indicator indicates the conditions that are necessary to satisfy the function of the logic block. The presence of the triangle indicates a 1 logic level on that line is needed to satisfy the function. The absence of the triangle indicates a logical 0 is needed to satisfy the function.

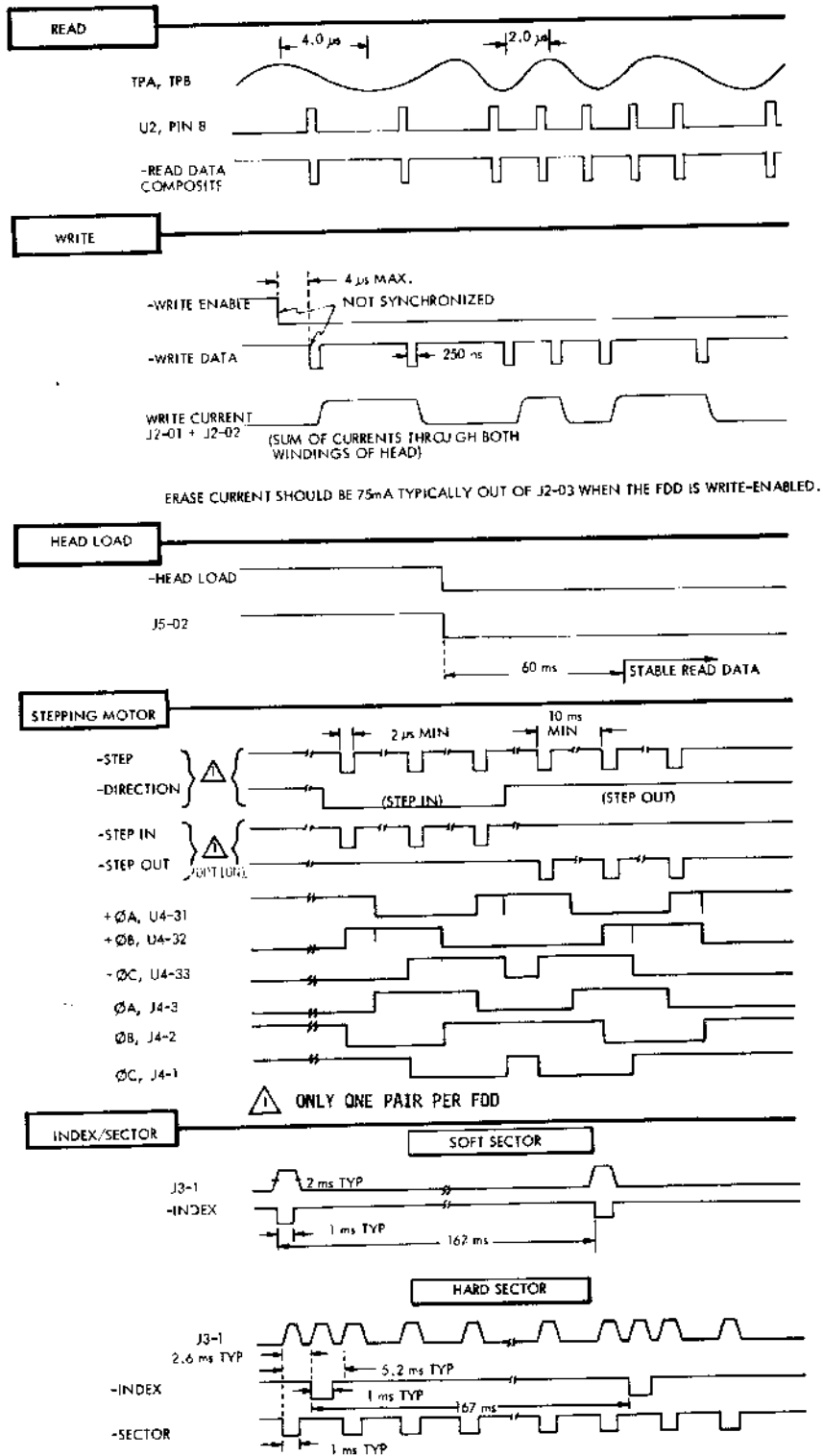

Z266a

FIGURE 5-1. TIMING

FIGURE 5-2. SCHEMATIC (SHEET 1 OF 2)

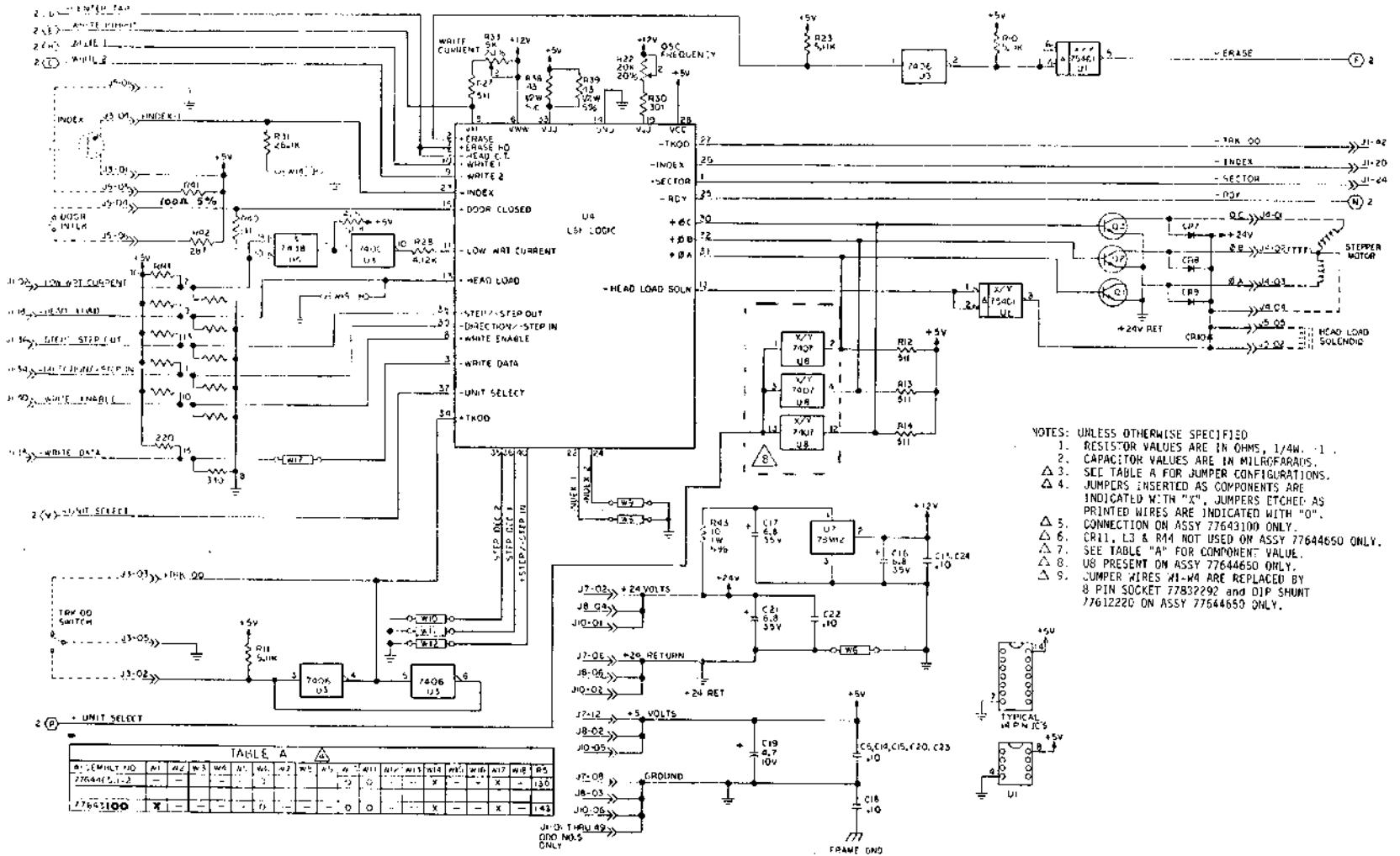
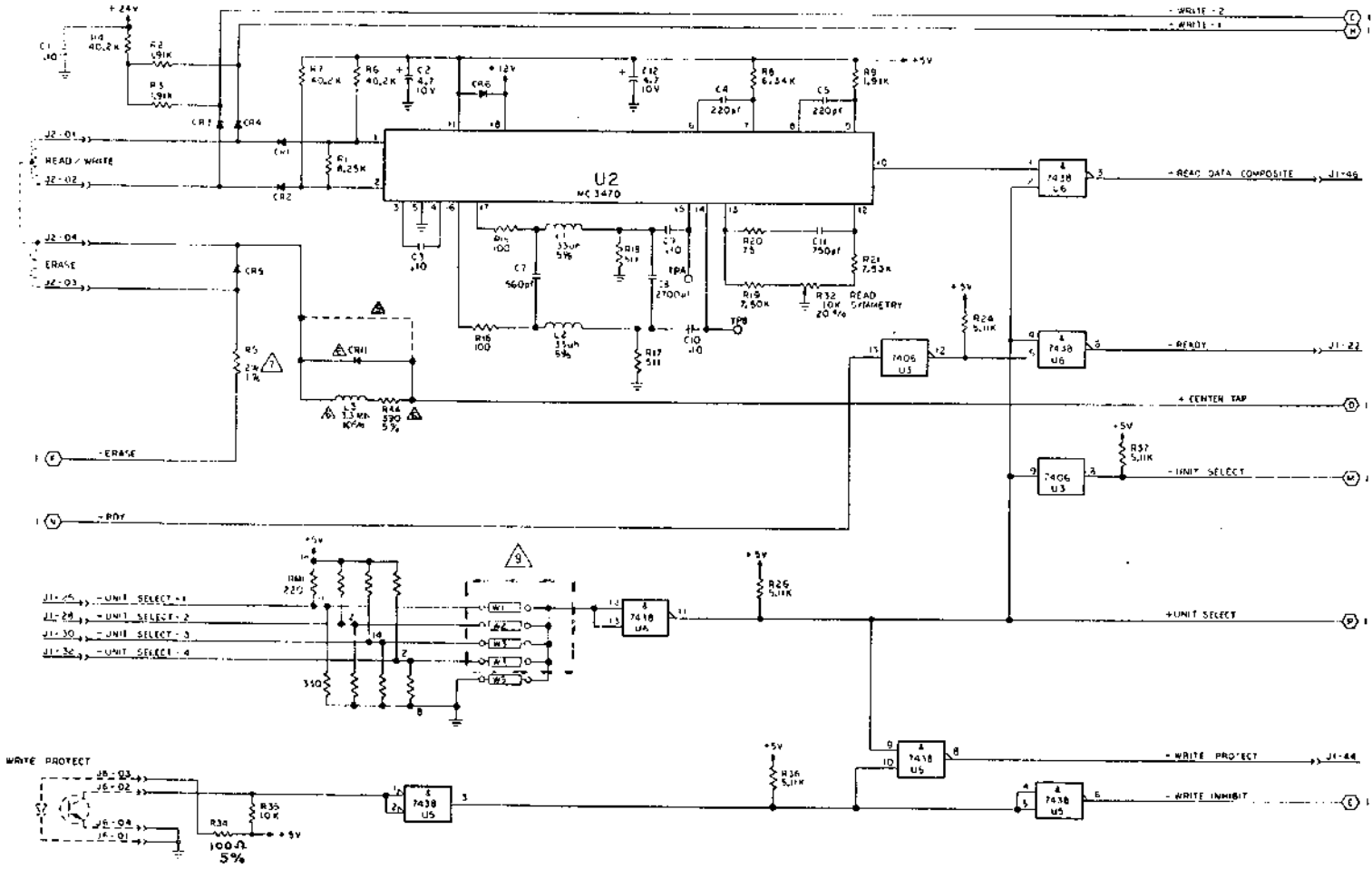
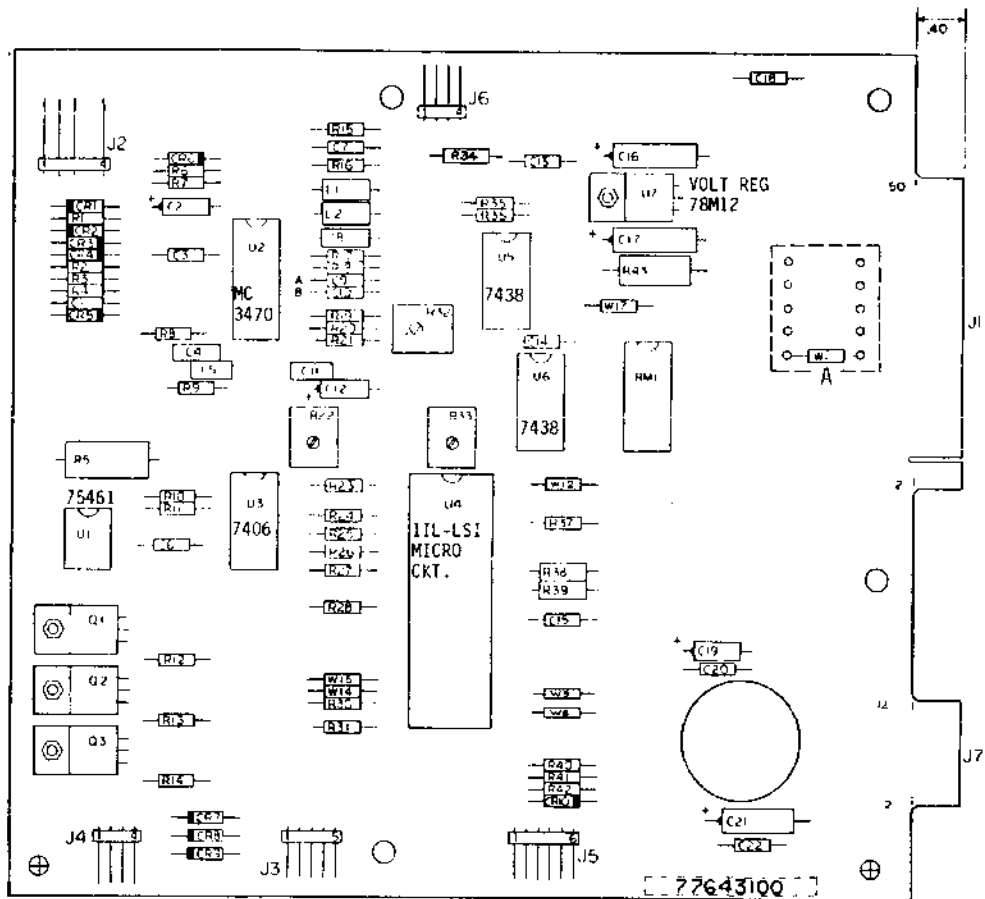
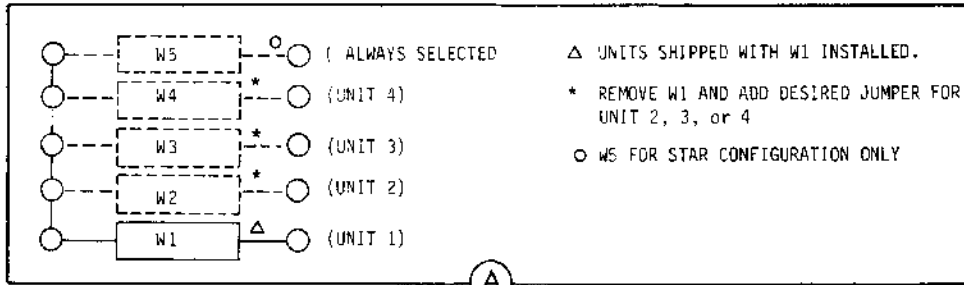

FIGURE 5-2. SCHEMATIC (SHEET 2 OF 2)





- TRANSISTORS
 Q1, Q2, Q3 - T1P120
- DIODES
 CR1, CR2, CR3, CR4, CR5 - 1N914A
 CR6, CR7, CR8, CR9, CR10 - 1N4001



Z267a

FIGURE 5-3A. ASSEMBLY AND PARTS LIST
 (PWA 77643100)

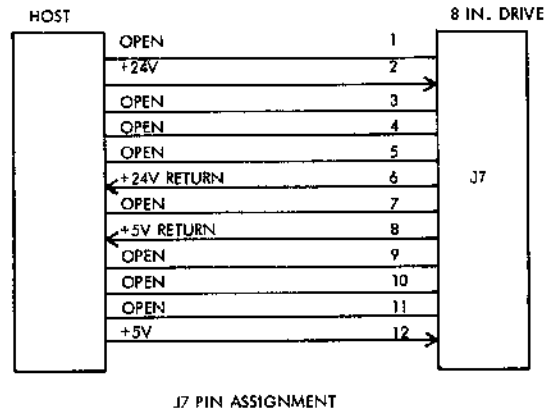
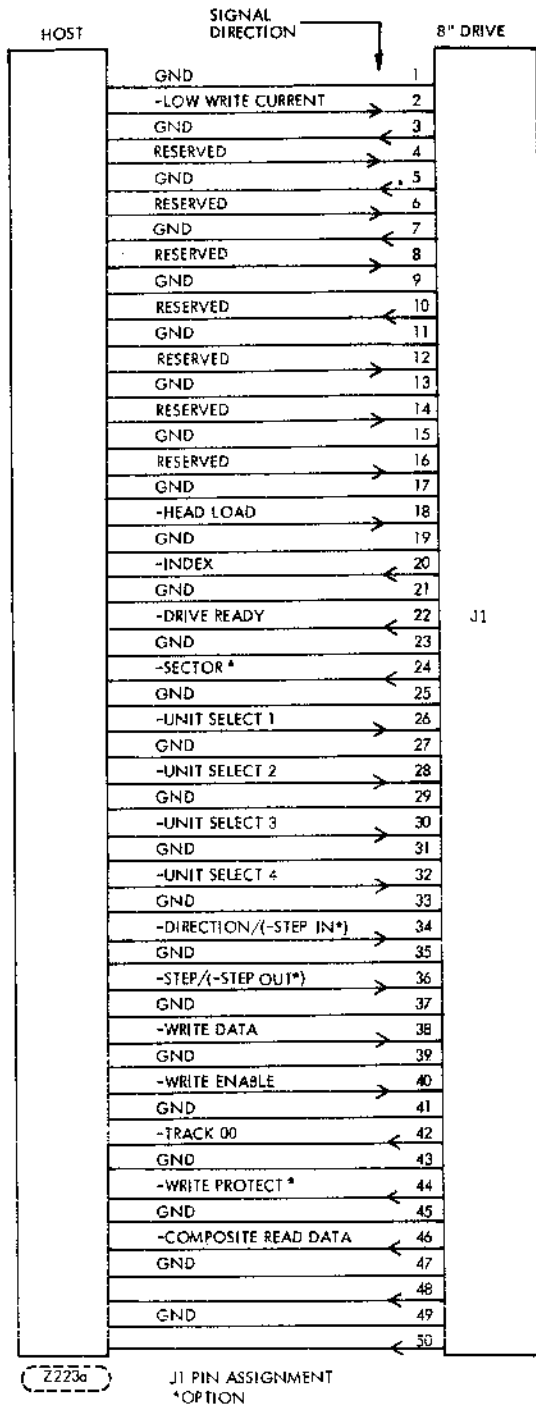

Z223b

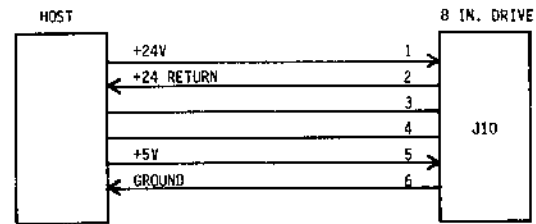

Z223c

* (USE ONLY ON 77644650 PWA)

FIGURE 5-4, J1, J10 AND J7 PIN ASSIGNMENTS

6.1 INTRODUCTION

This section contains the instructions required to maintain the FDD. The information is provided in the form of preventive maintenance, troubleshooting, and corrective maintenance.

6.2 MAINTENANCE TOOLS

The special tools (or equivalent) required to maintain an FDD are as follows:

<u>DESCRIPTION</u>	<u>CDC PART NUMBER</u>
Alignment Diskette (Optional)	Model 421-51W

The standard tools required to maintain the FDD are as follows:

- Socket Wrenches
 Sizes: 5/16" (7.94mm), 1/4" (6.35mm), 3/16" (4.76mm), 11/32" (8.73mm)
- Allen Wrenches
 Sizes: 0.050" (1.27mm), 1/16" (1.59mm), 5/64" (1.98mm), 7/64" (2.78mm)
- Oscilloscope, Tektronix 335, or equivalent.
- Feeler Gauges, wire
 Sizes: 0.030" (0.762mm), 0.058" (1.47mm), 0.060" (1.52mm), 0.062" (1.57mm), 0.079" (2.01mm)
- Feeler Gauge, Shim: 0.072" (1.83 mm), 0.020" (0.508 mm)
 0.010" (0.254 mm), 0.005" (0.127 mm)

6.3 PREVENTIVE MAINTENANCE

The head load pad should be inspected after 650 hours of head-load time. If pad is worn, dirty, torn, or loose it should be replaced. (See paragraph 6.7.4).

6.4 HEAD CLEANING

On occasions the Read/Write head may require cleaning. If this situation occurs clean head as follows:

CAUTION

Do not smoke while cleaning. Do not touch a head surface with fingers. Do not leave residue or lint on the head surfaces. Residual particles can result in a scored disk and/or loss of a head.

Do not raise head-load arm to the 90-degree position and then release it; damage to the load-arm spring and/or to the head (core and ceramics) could result.

- a. Use lint-free cloth to lightly drybuff head surface. Cleaning is completed if deposits are removed.
- b. If oxide deposits were not removed in step (a), dampen (do not soak) cloth with cleaning solution (91% isopropyl alcohol) and wipe head surface. Finish by lightly dry buffing again to ensure that the head is dry and no alcohol residue is left.

6.5 TROUBLESHOOTING

An improperly adjusted FDD may exhibit symptoms of one that has a malfunction; therefore, the Adjustment Procedures (paragraph 6.6) should be performed before assuming that the unit has failed. Before troubleshooting is started, check all DC supply voltages.

6.5.1 DC VOLTAGE AND SIGNAL

- a. Input power should be +5 VDC $\pm 5\%$ and +24 VDC $\pm 10\%$ measured at the input to the FDD (refer to paragraph 3.4.2).
- b. The signals should conform to the various diagrams and waveforms as shown in Figures 5-1, 6-1, 6-2, 6-3 and 6-4.

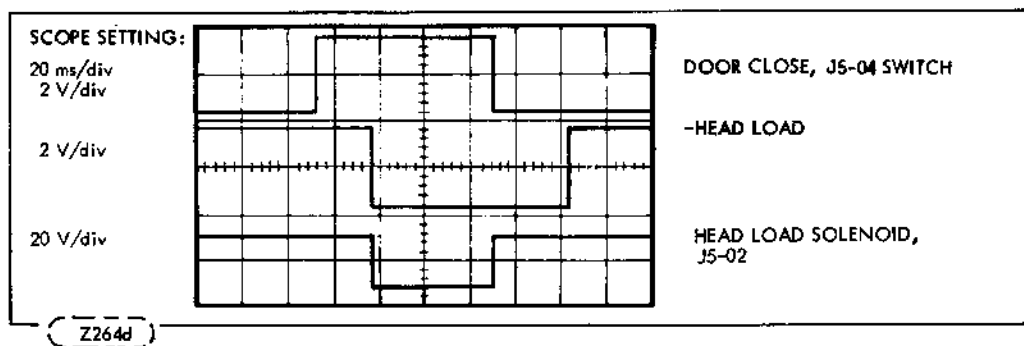

FIGURE 6-1. -HEAD LOAD AND DOOR INTERLOCK SWITCH

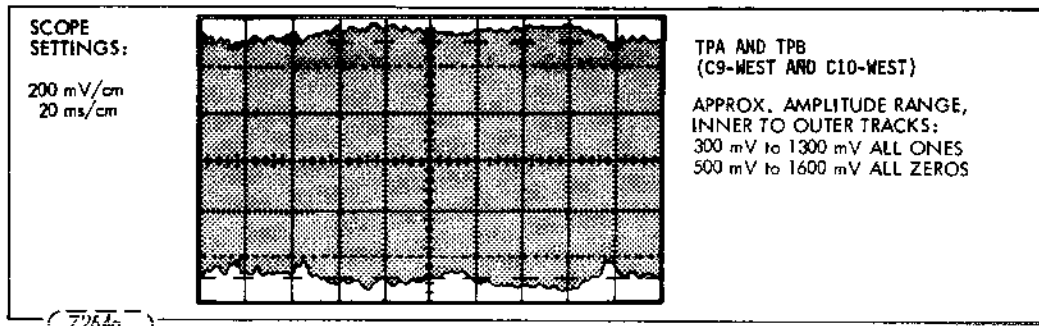

FIGURE 6-2. DIFFERENTIAL READ SIGNAL FOR ENTIRE TRACK

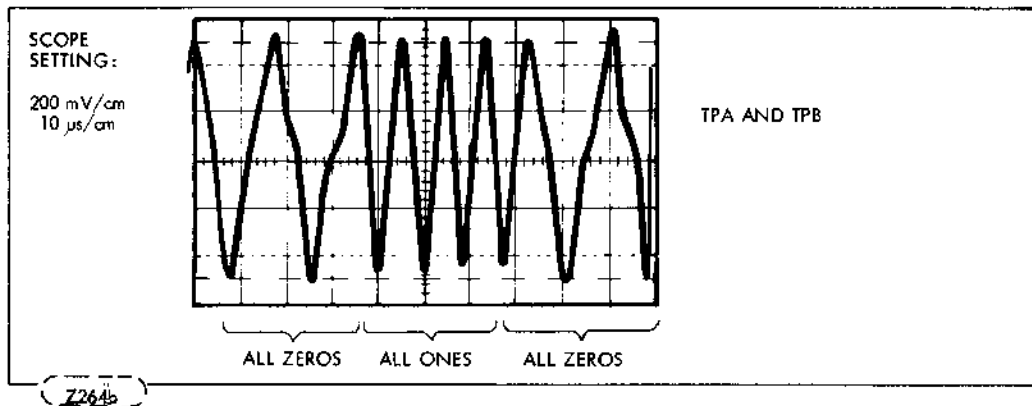

FIGURE 6-3. DIFFERENTIAL READ SIGNAL FOR PORTION OF OUTER TRACK

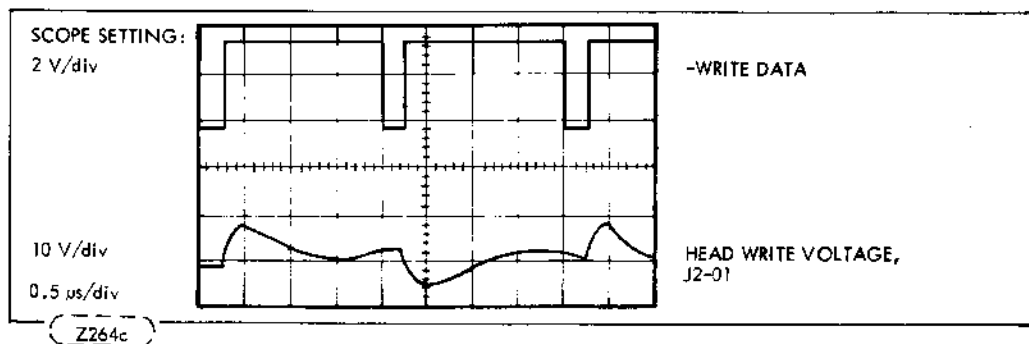

FIGURE 6-4. WRITE DATA AND HEAD WRITE VOLTAGE FOR OUTER TRACK

6.6 ADJUSTMENT PROCEDURES

6.6.1 CARRIAGE-STOP ADJUSTMENT

This procedure must be performed whenever actuator alignment or Track 00 adjustment has been performed.

- a. As shown in Figure 6-6, using a 0.020-inch (0.508 mm) shim, adjust outer (rear) stop clearance beyond track 00 and tighten rear screw, torque to 8-10 inch-lbs.
- b. Rotate the motor shaft manually to check for interference.

6.6.2 BURST-TO-INDEX CHECK AND ADJUSTMENT

The Alignment Diskette is used to perform this procedure.

- a. Precondition the alignment diskette (CDC 421-51W) by allowing it to reach room temperature for one hour.
- b. Install the alignment diskette.

CAUTION

The Alignment Diskette is for read only. Extreme caution should be used to assure this diskette is not written on.

- c. Seek to Track Zero, then seek to Track One and Read. (No data is recorded on Track One.)
- d. Connect Channel 1 of scope to TPA on the PWA, Channel 2 to Index J1-20 of the PWA. Set up the scope as follows:

Chan 1 Volt/Div to: 0.1 volt/div.

Chan 2 Volt/Div to: 2 volt/div.

Chan 1 voltage to: AC

Source to: Chan 1

Chan 2 voltage to: AC

Coupling to: Low Freq.

(Hi Freq. Reject)

Vert. Mode to: Add

Trig. Mode to: Normal

Slope (Sync) to: Pos.

Time Base to: 50 μ s/div

- e. Adjust the time from write splice bit to the leading edge of the index pulse until it measures $450 \pm 100 \mu$ s. (Refer to Figure 6-7) To adjust the write splice to index time, loosen the Allen head screw holding the phototransistor located on bottom of chassis toward the front of the unit. Using the adjustment handle protruding through the casting, move the phototransistor until the specification is met.
- f. Adjust the analog index pulse width to: greater than 1.6 ms for soft-sector applications, or 1.7 ± 0.1 ms for hard-sector applications. To make this adjustment, connect channel 2 of the scope to J3-04 and change the time base to 0.5 ms/div. Loosen the mounting screws on the Index LED Source Mount located on the top plate assembly (refer to Figure 6-9). Adjust the position of the LED mount until the analog Index pulse width observed on the scope is greater than 1.6 ms for soft sector or 1.7 ± 0.1 ms for hard sector, measured at the 50% amplitude point. Replace channel 2 of the scope to J1-20 and verify that the Write Splice-to-Index time is still $450 \pm 100 \mu$ s. Readjust if necessary.
- g. Repeat Steps e and f until the Write Splice-to-Index time and Index pulse width are both within specification. Tighten the hardware on both the phototransistor mount and LED mount and verify both adjustments stay within specification.

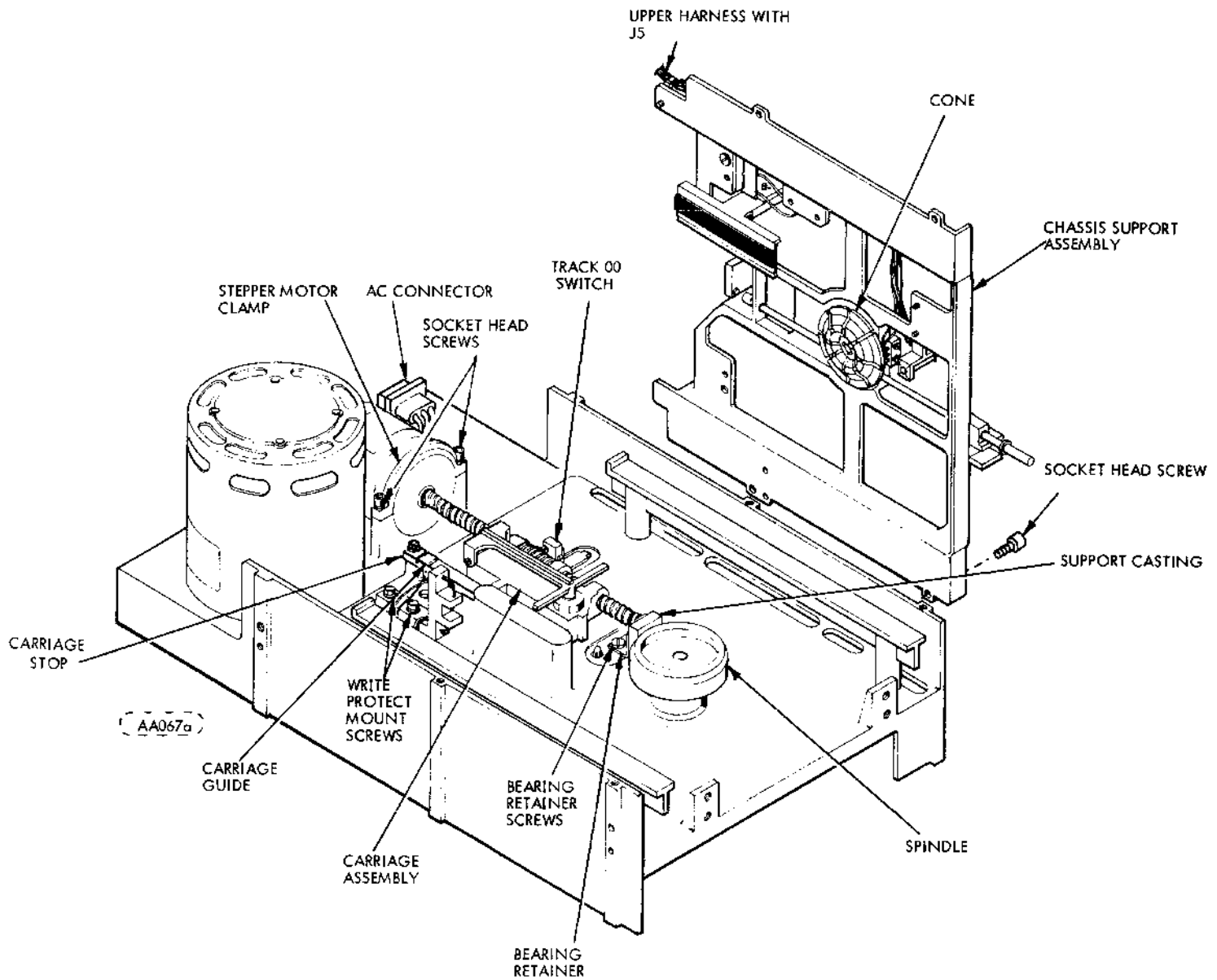
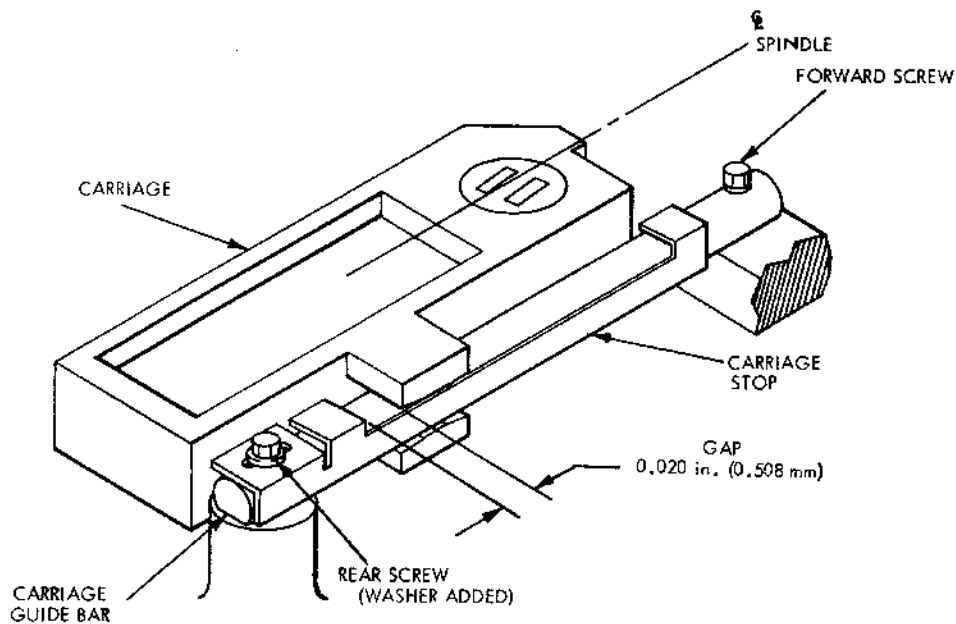

FIGURE 6-5. BASE AND CHASSIS SUPPORT ASSEMBLY



X327a

FIGURE 6-6. CARRIAGE-STOP ADJUSTMENT

- h. All scope settings are to remain as defined in the original setup in step "d", but it may be necessary to slightly adjust the sync. Seek to track 00 then seek to track 1 and perform a read. While observing the signal on the scope, remove and reinsert the diskette three times.

After each insertion, verify that the change in the time from write splice to leading edge of index is less than 50 μ s. If the change is greater than 50 μ s, the cone and spindle must be aligned or replaced (see Section 6.6.7) and steps "a" through "f" repeated.

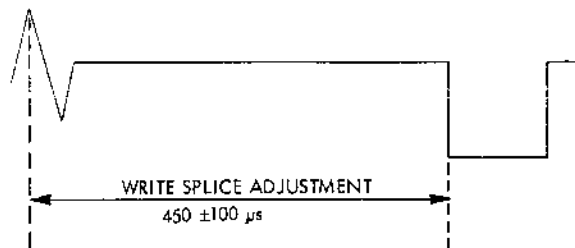

AA036c

FIGURE 6-7. WRITE SPLICE BIT TO INDEX TIMING

6.6.3 ACTUATOR ALIGNMENT (DISKETTE)

The Alignment Diskette is used to perform this procedure.

- a. Alignment Diskette 421-51W shall be preconditioned by allowing it to reach room temperature for one hour.
- b. Install the alignment diskette.

CAUTION

The alignment diskette is for read only.
Extreme caution should be used to assure
this diskette is not written on.

- c. Step to track 38 and perform a read. (No data is recorded on track 38. The tester or system requirements should be noted; refer to tester or system instructions for operation.)
- d. Connect Channel 1 of scope to TPA on the PWA and Channel 2 to TPB on the PWA.
- e. Connect the external sync probe to index at Index, J1-20 on PWA.
- f. Set up the scope as follows:

Channel 1: volts/div to: 0.1 volts/div
Channel 2: volts/div to: 0.1 volts/div (inverted)
Channel 1: input to: AC
Channel 2: inputs to: AC

Vertical Mode to: Add
Slope (Sync) to: Positive
Trigger Source to: External
Trigger Coupling to: Low Frequency (High Frequency Reject)
Trigger Mode to: Normal
Time Base to: 20 ms/div

NOTE

Scope trace after trigger level is adjusted for repetitive trace should display an envelope of data "Cateyes" consisting of two lobes (refer to Figure 6-8). If no such pattern can be displayed, manually turn the stepper motor shaft extending from the rear of the stepper motor one-quarter turn either way to locate pattern. Then proceed to Step "h."

- g. Change the volts/div of Channel 1 and Channel 2 to 0.02 volts/div. Move the trace on the scope (Position Knob) up until the bottom of the two lobes are setting approximately on the base line (refer to Figure 6-8). For an acceptably aligned unit, the voltage ratio of the smaller lobe to the larger lobe should exceed 80%.
- h. If not in alignment, loosen the stepper motor clamp mounting screws to where a gap exists between the clamp and casting (see Figure 6-9) and slowly rotate the stepper motor to adjust the amplitude until the amplitude of both lobes is the same, that is, the difference between the bottoms of both lobes is less than 5 mV.

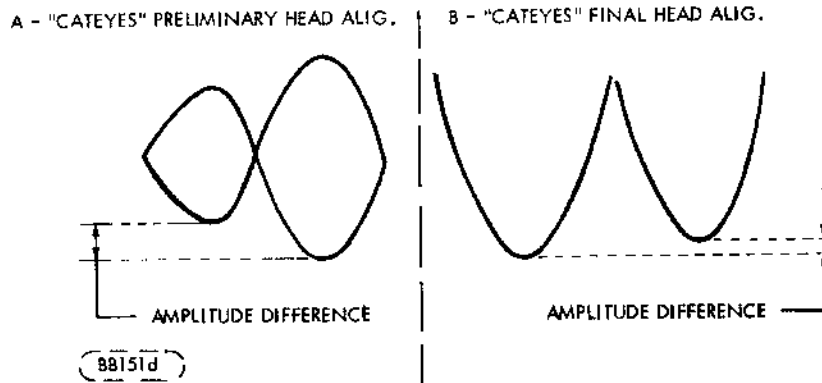

FIGURE 6-8. HEAD ALIGNMENT AMPLITUDE

- i. Tighten the stepper motor clamp. Return to track 00, then seek back to track 38. Verify that the 5 mV specification is still met. If the specification is not met, readjust the stepper motor, return to zero and seek back to track 38. Repeat the adjustment until the 5 mV specification is met.
- j. Verify that the amplitude of the smaller lobe exceeds 200 mV p-p. If it does not, replace the media and repeat the adjustment.
- k. Remove alignment diskette.
- l. Perform Track 00 Switch Adjustment per Paragraph 6.6.9.
- m. Perform Stop Gauge Adjustment per Paragraph 6.6.1.
- n. Recheck all adjustments made in this procedure and repeat all steps having out-of-tolerance indications.

6.6.4 PUSH-ROD TRAVEL ADJUSTMENT

This procedure must be performed whenever chassis support (Figure 6-9) is removed and replaced.

- a. With front panel door closed, verify that a gap exists between the retaining ring and the disk load bushing between 0.025 and 0.045 in. (0.635 and 0.143 mm) (refer to Figure 6-9). Perform Steps b and c if out of adjustment.
- b. Back-off the Door Interlock Switch Adjustment set screw.
- c. Adjust disk load arm set screw (Figure 6-9) until gap is approximately 0.030 in. (0.762 mm), with door closed.
- d. Proceed to Door Interlock Switch Adjustment (paragraph 6.6.5)

6.6.5 DOOR-INTERLOCK SWITCH ADJUSTMENT

This procedure must be performed whenever the Push-Rod Travel Adjustment procedure is performed.

- a. Verify that interlock switch closes (when closing the door) prior to the door latching. Perform step (b) if switch and door are out of sync.
- b. With door closed, adjust set-screw at end of disk load arm (Figure 6-9) while holding door closed against metal stop. Adjust set-screw until micro-switch is almost adjusted flush to top of switch case. This ensures that as the nylon tips on the push-rod wear down, the switch will still close.

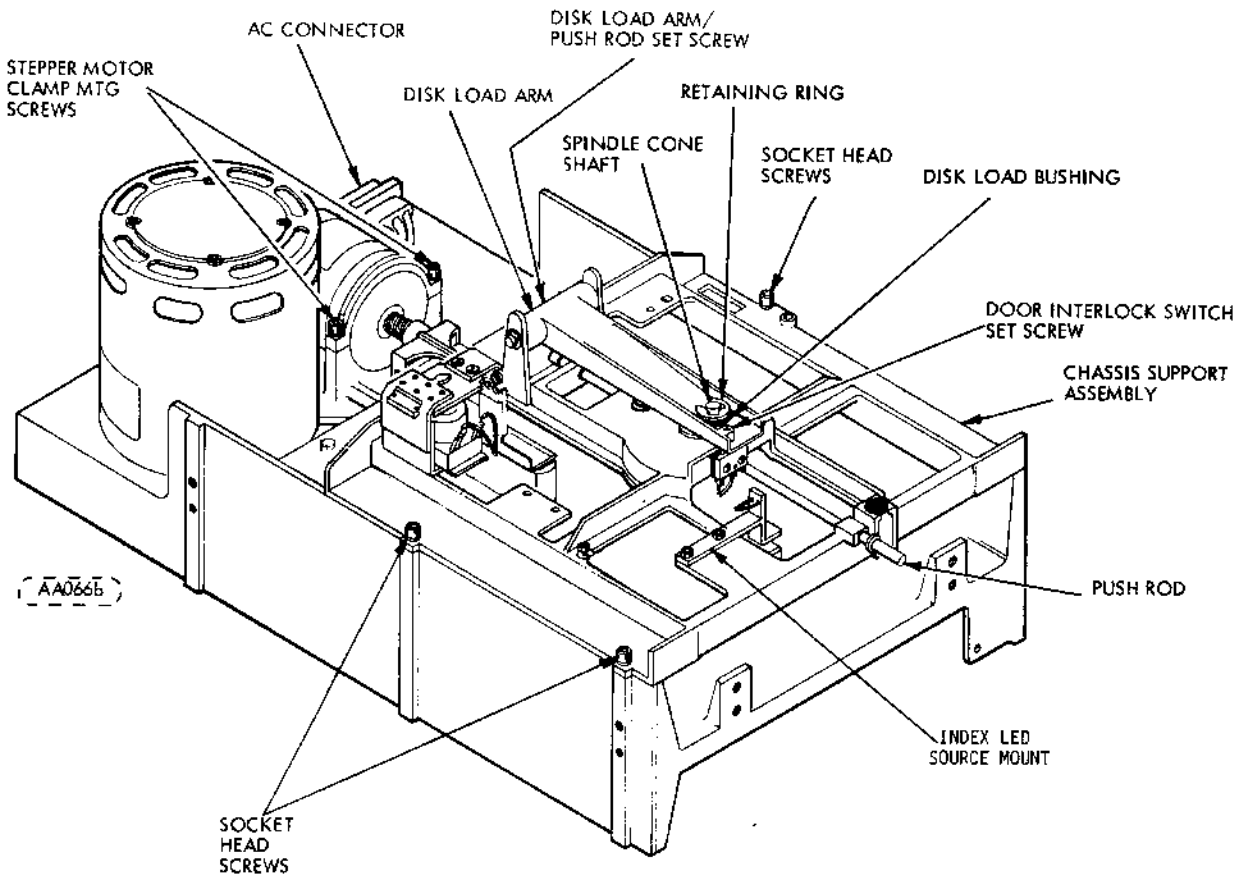

FIGURE 6-9. CHASSIS BASE ASSEMBLY

6.6.6 DISK-LOAD BAIL ADJUSTMENT

This procedure must be performed whenever the solenoid or bail are removed or the screw holding the bail becomes loose.

- a. Place a 0.010 in. (0.254 mm) feeler gauge on boss of bottom support casting underneath bail.
- b. Energize solenoid.
- c. Loosen mounting screw on bail (Figure 6-10).
- d. Adjust Bail so the foam pad touches the feeler gauge.
- e. Tighten mounting screw.

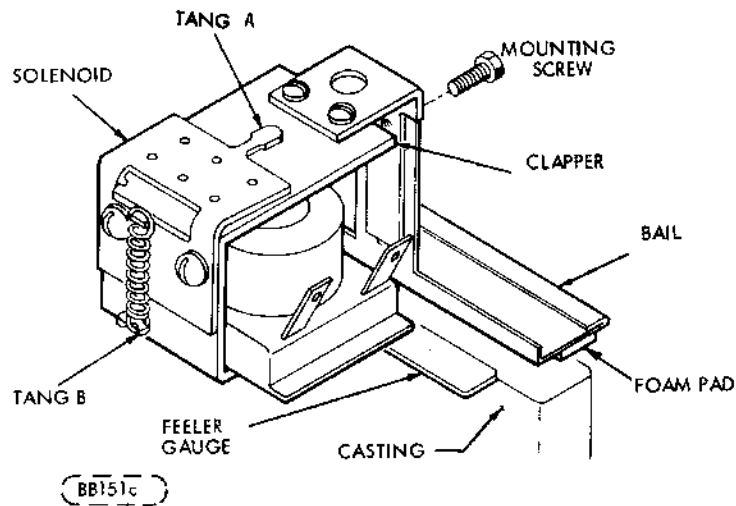

FIGURE 6-10. DISK LOAD SOLENOID

6.6.7 SPINDLE AND CONE ADJUSTMENT

This procedure must be performed whenever the spindle and cone are out of alignment or whenever the actuator assembly is removed or replaced.

- a. Loosen chassis support assembly (Figure 6-9).
- b. Apply AC power to the FDD.
- c. Position chassis assembly by pushing down on the spindle cone shaft so cone seats in the spindle (Figure 6-11). Visually verify that all segments on the cone are fully seated in the spindle.
- d. Secure socket head screws (Figure 6-9).
- e. Fully open and close door four times. Verify that after each closing all cone segments are fully seated. Verify that the load arm does not bind when door is opened and closed.
- f. Perform Push-Rod Travel Adjustment and adjust if necessary (paragraph 6.6.4).

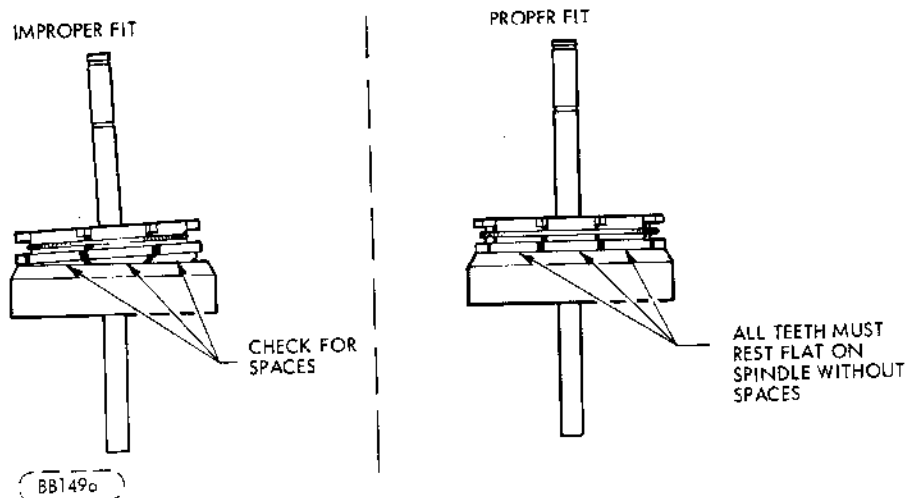

FIGURE 6-11. SPINDLE AND CONE

6.6.8 WRITE-PROTECT-ASSEMBLY ADJUSTMENT (WHERE APPLICABLE)

This adjustment will be required whenever the unit is disassembled, or a different style diskette is utilized in the unit.

- a. With a Write-Protected diskette installed in the unit (Write-Protect slot uncovered), monitor U5 pin 4/R36-East for the WRITE PROTECT signal. A continuous logically high signal will be present whenever the Write-Protect assembly is properly adjusted. A logically low signal will appear if not properly adjusted.
- b. To adjust, loosen the two hex-head screws holding the sensor mount in place. With the front panel door open, push down on the disk load arm (Figure 6-9) to insure that the disk is in the loaded position. At the same time, grasp the end of the envelope and move from side-to-side, and forward and backward while observing the WRITE-PROTECT signal at U5 pin 4/R36-East. Adjust the mount until the WRITE-PROTECT signal is present for any position of the envelope.
- c. Tighten the mount screws, and re-check to verify signal under all conditions of envelope position.

6.6.9 TRACK '00' SWITCH ADJUSTMENT

Perform the procedure given below whenever the Track 00 switch has been replaced, or the device fails to give current Track 00 indication, or if the head has been realigned.

- a. Step the Read/Write head out to Track 01.
- b. Place a 0.010 (0.254 mm) feeler gauge between the carriage assembly and Track 00 switch.
- c. Verify that the Track 00 switch closes by observing a low level at terminal J3-2 on the Component Board Assembly.
- d. If the low level does not occur, loosen the Track 00 switch-bracket mount screw and rotate the switch bracket forward until the low level occurs.
- e. Place a 0.005 (0.127 mm) feeler gauge between the carriage assembly and Track 00 switch after removing the 0.010 (0.254 mm) feeler gauge.
- f. Verify that the Track 00 switch remains open by observing a high level at terminal J3-2 on the Component Board Assembly.
- g. If the high level does not occur, loosen the Track 00 switch-bracket mount screw and rotate the switch bracket backward until the high level occurs.
- h. Repeat "b" through "g" until criteria in "c" and "d" are both satisfied.

6.7 REMOVAL AND REPLACEMENT PROCEDURES

The following procedures give the proper sequence for removal and replacement of major assemblies. To avoid damage to parts, the procedure must be performed in sequence.

6.7.1 PRINTED CIRCUIT BOARD (PWA)

- a. Disconnect I/O cable from J1.
- b. Disconnect DC power cable from J7, and AC power from FDD.
- c. Disconnect harnesses from connectors on printed-circuit board.
- d. Remove two screws from printed-circuit board adjacent to connector J1 (Figure 6-12).
- e. Remove PWA by detaching it from the two push-in clips shown in Figure 6-12.
- f. To replace printed-circuit board, push clips through printed-circuit board.
- g. Replace two screws adjacent to connector J1.
- h. Reconnect harnesses, I/O cable, DC power cable, and AC power cable.
- i. Perform Burst-to-Index Check and adjust if necessary (paragraph 6.6.2).

6.7.2 ACTUATOR ASSEMBLY

- a. Open front-panel door.
- b. Disconnect harness from J2 and J4 on printed-circuit board (see Figure 5-3).
- c. Remove four (4) socket-head screws securing chassis support (Figure 6-9).
- d. Slide chassis support back far enough to clear push rod (Figure 6-9) of front panel and lift support clear of chassis.
- e. Remove two (2) screws securing bearing retainer (Figure 6-5).
- f. Remove stepper-motor clamp by removing two socket-head screws (Figure 6-5). Remove Cable Clamp.
- g. Carefully slide actuator assembly (stepper motor, actuator, and bearings at the end of stepper shaft) straight out toward the rear of the FDD until unit is clear of the casting.
- h. To replace actuator assembly, slip bearings into support casting, Figure 6-5. (Assure carriage assembly is fitted on carriage guide.)

CAUTION

The wavy spring washer between the two bearings can prevent the bearings from being inserted into the support casting if the washer has slipped off-center and protrudes beyond the circumference of the bearings. If this happens, loosen the retainer screw on the end of the shaft so the bearings can separate and the washer can be repositioned. The screw must be retightened after the bearings are successfully inserted.

- j. Replace stepper-motor clamp and two socket head screws (Figure 6-5).
- k. Secure the bearing retainer by replacing the two bearing retainer screws (Figure 6-5).

CAUTION

The bearing retainer clamp should have an included angle of approximately 92° between the base and side. When base is securely fastened to chassis, this will assure proper tension on bearings. If a gap exists between bearing and retainer or if bearing is being bound up by retainer, this angle must be checked.

- l. Replace harness at J2 and J4 of PWA (Figure 5-3).
- m. Perform Actuator Alignment Procedure, (paragraph 6.6.3).
- n. Perform Spindle and Cone Adjustment, (paragraph 6.6.7).
- o. Perform Push-Rod Travel Adjustment, (paragraph 6.6.4).

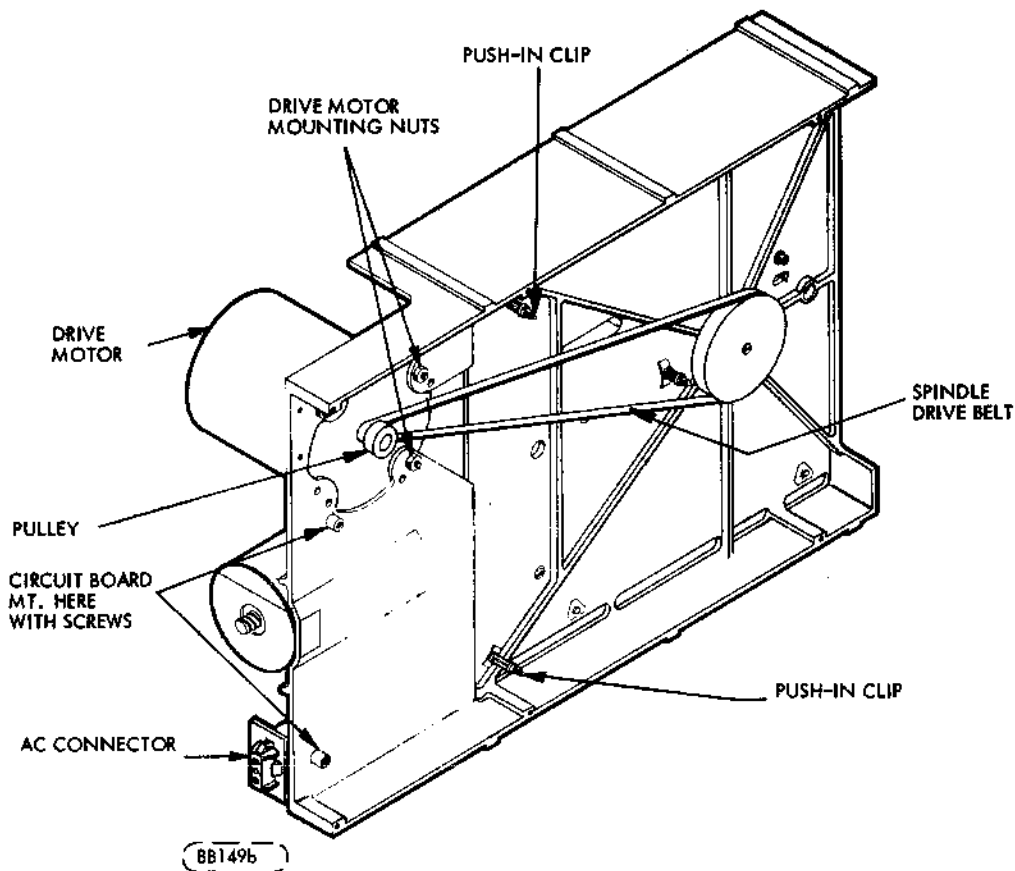

FIGURE 6-12. BASE CASTING ASSEMBLY .

6.7.3 DRIVE-MOTOR ASSEMBLY

- a. Perform removal procedure for printed-circuit board (paragraph 6.7.1).
- b. Remove screws securing drive-motor cable clamps.
- c. Remove AC connector from bracket. (Figure 6-12)
- d. Remove hex-head screw securing ground wire to chassis.
- e. Remove spindle drive belt (Figure 6-12).
- f. Remove three (3) nuts securing drive motor (Figure 6-12).
- g. Remove drive-motor assembly (drive motor and AC connector).
- h. To replace drive-motor assembly perform, in reverse order, Steps g through a substituting the word "replace" for the word "remove."

6.7.4 HEAD-LOAD-PAD REPLACEMENT

CAUTION

Do not raise the head-load arm to the 90-degree position and then release it; damage to the load-arm spring and/or to the head (core and ceramics) could result.

- a. Remove power from the unit.
- b. Move the carriage assembly to its rear most position (toward the stepper motor) by turning the aft part of the stepper motor shaft (Figure 6-13). This will provide clearance for lifting the head load arm.
- c. Lift the head load arm until the head load pad is visible (see Figure 6-13).
- d. Loosen clamping screw holding rim of head-load pad.
- e. Insert screw driver and rotate head-load pad so flattened side will clear clamping screw.
- f. Remove Pad Holder Assembly.
- g. Insert new Assembly, with flat side toward clamping screw.
- h. Assuring that head load pad is fully seated, rotate pad 180 degrees.
- i. Tighten clamping screw to hold pad in place.
- j. Lower arm gently onto head.

6.7.5 SOLENOID REPLACEMENT AND TANG ADJUSTMENT

This procedure must be performed whenever the solenoid is out of alignment or whenever the solenoid assembly is replaced.

- a. Place the tapered end of a flat-head screw driver between Tang A and solenoid clapper. (See Figure 6-10.)
- b. Gently bend the tang upward with the screwdriver.
- c. Using a 0.060-in. (1.52 mm) wire feeler gauge, insert the feeler gauge in the gap between the underside of the clapper and the coil core. (See Figure 6-14.)
- d. If unable to insert 0.060-in. (1.52 mm) wire feeler gauge, continue to gently bend tang upward until feeler gauge can be inserted.
- e. Next, attempt to insert a 0.062-in. (1.57 mm) wire feeler gauge between the underside of the clapper and the coil.
- f. If this gauge can be inserted, bend tang down until a 0.062-in. (1.57 mm) feeler gauge will not insert in the gap between the clapper and the coil core.

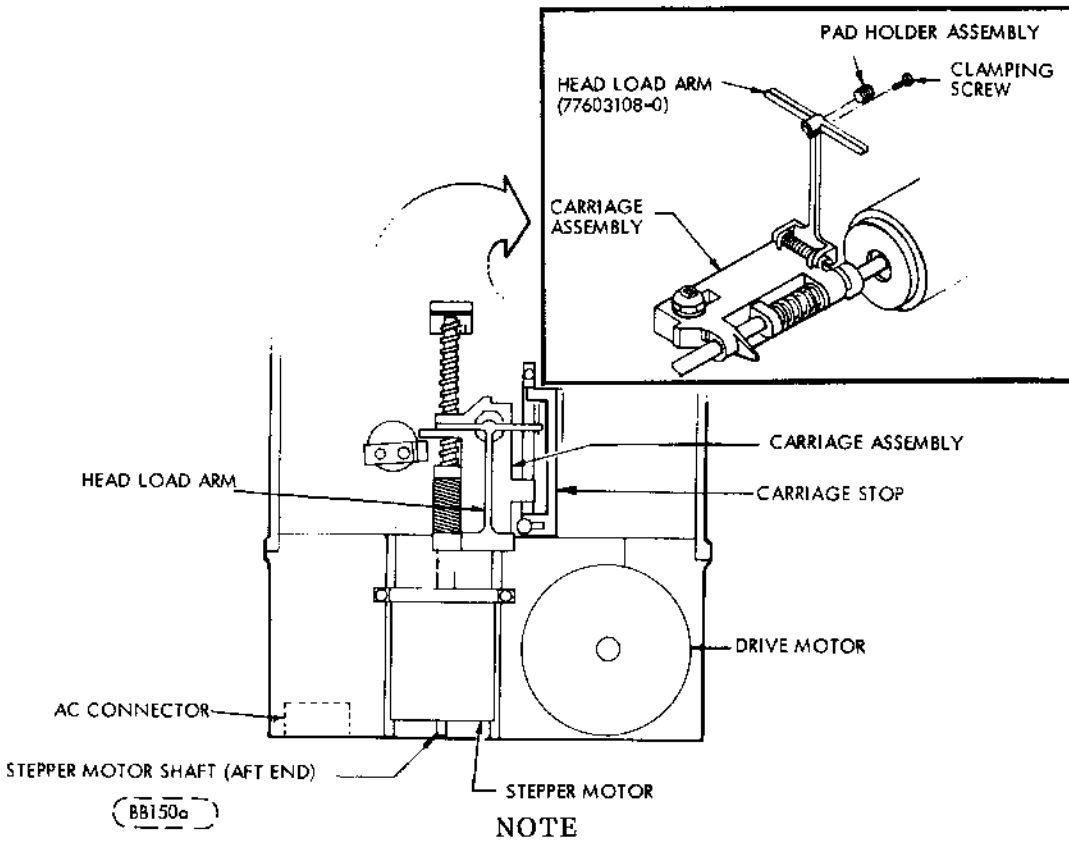

FIGURE 6-13. HEAD-LOAD-PAD REPLACEMENT ILLUSTRATION

- g. Insert a 0.058-in. (1.47 mm) wire feeler gauge in the gap between the underside of the clapper and the coil core.
- h. If 0.058-in. (1.47 mm) feeler gauge will not fit, bend the tang up slightly.
- i. Continue checking with the 0.062-in. (1.57 mm) wire gauge feeler and 0.058-in. (1.47 mm) wire gauge until the following condition is achieved:
 1. 0.062-in. (1.57 mm) feeler gauge will not pass between tang and clapper;
 2. 0.058-in. (1.47 mm) feeler gauge passes freely between tang and clapper.
- j. Check the spring adjustment by gently pressing down on the clapper until the 0.060 in. (1.52 mm) \pm 0.002-in. (0.051 mm) gap is closed.
- k. Allow the clapper to rise slowly and release.
- l. The clapper should be in contact with the tang.
- m. If not, bend the lower tang B, Figure 6-10, downward gently.
- n. Recheck that the clapper rises and perform Step "m" until the clapper and tang make contact.
- o. Check the bail adjustment per paragraph 6.6.6.

6.7.6 CARRIAGE AND/OR STEPPER MOTOR REPLACEMENT

The carriage and stepper motor are to be replaced as one assembly, being factory assembled and tested only. Refer to Section 6.7.2.

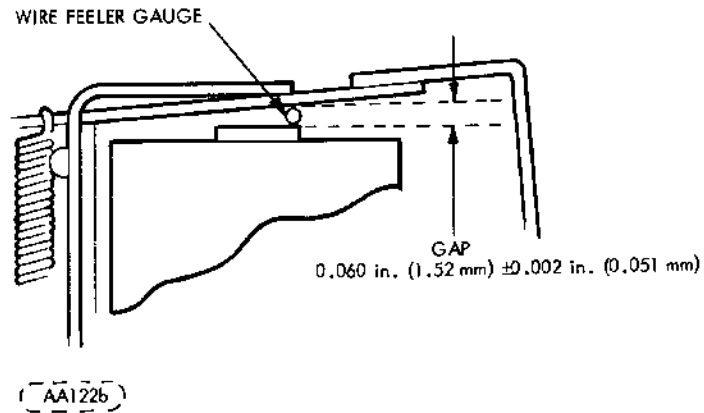

FIGURE 6-14. SOLENOID ADJUSTMENT

6.8 FREQUENCY CONVERSION

6.8.1 OPERATING FREQUENCIES CONVERSION PROCEDURE

This procedure is to be used to convert the FDD unit from 60 Hz operation to 50 Hz operation or vice versa. This is accomplished by reversing the dual diameter reversible pulley on the spindle motor shaft (Figure 6-12) using the following steps:

- Remove AC power.
- Remove Printed Circuit Board Assembly.
- Remove the belt from the spindle motor pulley. (Accessible from the under side of unit).
- Loosen set-screw and remove pulley.
- Reverse pulley and replace on motor shaft.
- Position pulley allowing 0.079 in. (2.01 mm) \pm 0.010 in. (0.254 mm) between shoulder of motor mounting screws and pulley (Figure 6-15).
- Tighten down set-screw.
- Replace belt and Printed Circuit Board.

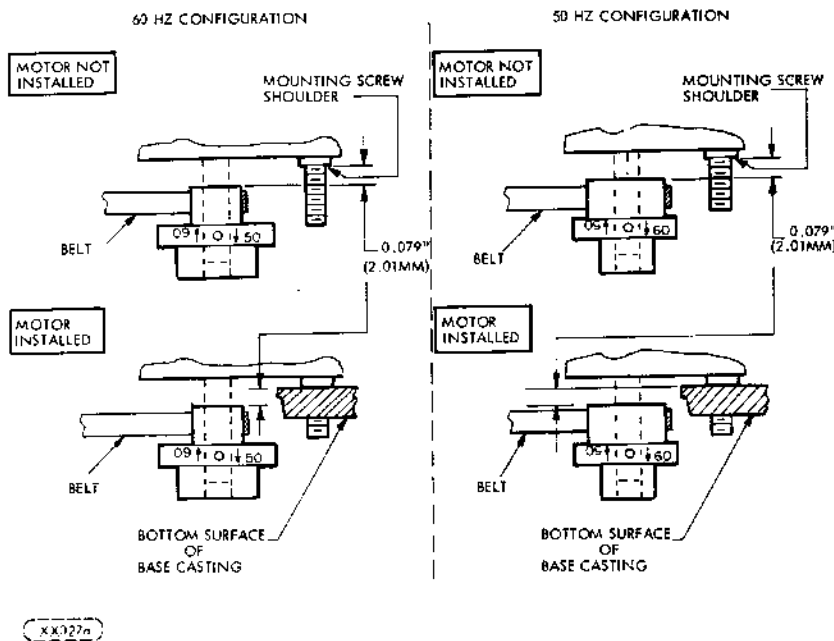

FIGURE 6-15. DRIVE PULLEY REVERSAL

NOTE: When converting from 60 Hz to 50 Hz, the same belt may be used. When converting from 50 Hz to 60 Hz, a new belt must be installed.

7.1 INTRODUCTION

The following paragraphs contain the wire lists for the Upper Harness Assembly, Lower Harness Assembly and the Stepper Motor.

7.2 UPPER HARNESS ASSEMBLIES

<u>Wire Color</u>	<u>Origin</u>	<u>Destination</u>	<u>Approximate Length Inches</u>
Red	Solenoid-A	J5-5	11.0" (279.4mm)
Black	Solenoid-B	J5-2	11.0" (279.4mm)
Orange	Interlock Common	J5-6	13.5" (342.9mm)
White	Interlock N. O.	J5-4	13.5" (342.9mm)
Blue	LED Cathode	J5-1	13.5" (342.9mm)
Yellow	LED Anode	J5-3	13.5" (342.9mm)

7.3 LOWER HARNESS ASSEMBLY

<u>Wire Color</u>	<u>Origin</u>	<u>Destination</u>	<u>Approximate Length Inches</u>
Black	Track 0 Common	J3-5	20.0" (508.0mm)
Red	Track 0 N. C.	J3-3	20.0" (508.0mm)
White	Track 0 N. O.	J3-2	20.0" (508.0mm)
Blue	Photo Transistor Emitter	J3-4	9.0" (228.6mm)
Yellow	Photo Transistor Collector	J3-1	9.0" (228.6mm)

7.4 STEPPER MOTOR

<u>Wire Color</u>	<u>Origin</u>	<u>Destination</u>	<u>Approximate Length Inches</u>
Brown	Stepper Motor	J4-1	13.0" (330.2mm)
Red	Stepper Motor	J4-2	13.0" (330.2mm)
Orange	Stepper Motor	J4-3	13.0" (330.2mm)
Black	Stepper Motor	J4-4	13.0" (330.2mm)

7.5 WRITE PROTECT

<u>Wire Color</u>	<u>Origin</u>	<u>Destination</u>	<u>Approximate Length Inches</u>
Blue	LED Cathode	J6-1	20.0" (508.0mm)
Red	Phototransistor Collector	J6-2	20.0" (508.0mm)
Green	LED Anode	J6-3	20.0" (508.0mm)
White	Phototransistor Emitter	J6-4	20.0" (508.0mm)

PARTS DATA

8.1 INTRODUCTION

This section contains an illustrated parts breakdown that describes and illustrates all variations of the Flexible Disk Drive (FDD). In general, parts are in disassembly sequence but do not necessarily indicate the maximum recommended disassembly of parts in the field.

8.2 ILLUSTRATIONS

Item numbers within a circle 1 indicate an assembly (group of parts). Item numbers without a circle, 1, indicate a single part; a group of parts that are pinned or press fitted together; or a group of parts which is normally replaced as an assembly.

8.3 PARTS LISTS

In addition to the accompanying parts list on each illustration, two additional Parts Lists are available; the Top-Down Assembly/Component Parts List and the Cross Reference Index. Instruction for the use of all Parts lists in paragraph 8.6.

8.4 TOP MECHANICAL AND ASSEMBLY LOCATION

In conjunction with Table 8-1, Figure 8-1 serves two purposes;

1. When used with Table 8-1, it identifies all unique parts and assemblies for each FDD variation.
2. It identifies by sheet location where all major assemblies are broken down.

8.4.1 TOP MECHANICAL ASSEMBLY (TMA)

To determine what parts are used on a particular model, find the applicable model in Table 8-1. The corresponding item number represents the last three digits of the TMA number. Example: Model BR803N, TMA number 75744013. The item numbers at the top of Table 8-1 corresponds with the item numbers in Figure 8-1. All parts and assemblies that apply will be identified with an 'X' ('0' means not applicable).

8.5 REPLACEMENT PARTS

When ordering replacement parts for the FDD, the inclusion of the Model designation and the figure, item and part identification numbers for each part ordered will ensure positive identification of parts. Before ordering parts however, refer to paragraph 8.7 spare parts.

NOTE

Replacement parts for all OEM engineering evaluation units (BRXXXX TMA099) must be obtained from MPI OEM Engineering.

ITEM IDENT NO	DESCRIPTION	WHERE USED	ITEM IDENT NO	DESCRIPTION	WHERE USED
101 83458201	CHASSIS ASM-COMMON PARTS	TMA	138 75791511	ACTUATOR ASM	TMA
102 75291920	DRIVE MOTOR ASM 60 HZ	TMA	139 75774736	CLIP-PUSH IN	TMA
103 75291923	DRIVE MOTOR ASM 50 HZ	TMA	140 77830685	UPPER HARNESS ASM	TMA
104 75291926	DRIVE MOTOR ASM 60 HZ	TMA	141 75747301	UPPER HARNESS ASM	TMA
105 75291927	DRIVE MOTOR ASM 50 HZ	TMA	142 83403504	LOWER HARNESS ASM	TMA
106 75291928	DRIVE MOTOR ASM 50 HZ	TMA	143 83403503	LOWER HARNESS ASM	TMA
107 75291925	DRIVE MOTOR ASM 50 HZ	TMA	144 83403700	CONNECTOR BRACKET	TMA
108 75888178	DRIVE MOTOR ASM 50 HZ	TMA	145 75272300	CONNECTOR BRACKET	TMA
109 75881775	DRIVE MOTOR ASM 60 HZ	TMA	146 77830538	CSA LABEL	TMA
111 75291921	DRIVE MOTOR ASM 60 HZ	TMA	147 77594901	TRACK SWITCH ASM	TMA
112 77834213	DRIVE MOTOR ASSY	TMA	148 83450101	AMP CONN KIT	TMA
113 75291924	DRIVE MOTOR ASM 60 HZ	TMA	149 75746702	CAPACITOR BRACKET	TMA
114 77834214	DRIVE MOTOR ASSY	TMA	150 75898080	FRONT PANEL ASM	TMA
115 75891480	CHASSIS ASM-COMMON PARTS	TMA	151 83401809	FRONT PANEL ASM	TMA
122 94277416	STRAP, CABLE TIE	TMA	152 77822691	MOUNTING KIT	TMA
124 75291902	DRIVE MOTOR ASM 50 HZ	TMA	155 93592240	SCREW-WASHER	TMA
125 83427801	WRITE PROTECT ASM	TMA	156 77830641	AC CONN & RELAY ASM	TMA
127 77830690	DISKETTE DETECT ASM	TMA	157 77830995	COVER	TMA
128 75881779	DRIVE MOTOR ASM 60 HZ	TMA	158 17901508	SCREW	TMA
129 75881780	DRIVE MOTOR ASM 60 HZ	TMA	160 77834336	LABEL, FCO	TMA
130 75888181	DRIVE MOTOR ASM 50 HZ	TMA	161 77834543	FRONT PANEL ASSY	TMA
131 83401806	FRONT PANEL ASM	TMA	162 75746701	CAPACITOR BRACKET	TMA
132 83401801	FRONT PANEL ASM	TMA	164 77836055	LABEL	TMA
133 83401802	FRONT PANEL ASM	TMA	166 83401812	FRONT PANEL ASSY	TMA
134 83401803	FRONT PANEL ASM	TMA	167 83401811	FRONT PANEL ASSY	TMA
135 83401804	FRONT PANEL ASM	TMA	168 77594704	CPT TRACK SENSE ASSY	TMA
136 83401805	FRONT PANEL ASM	TMA	169 77594705	CPT TRACK SENSE ASSY	TMA
137 75791510	ACTUATOR ASM	TMA	170 83401808	FRONT PANEL ASSY	TMA

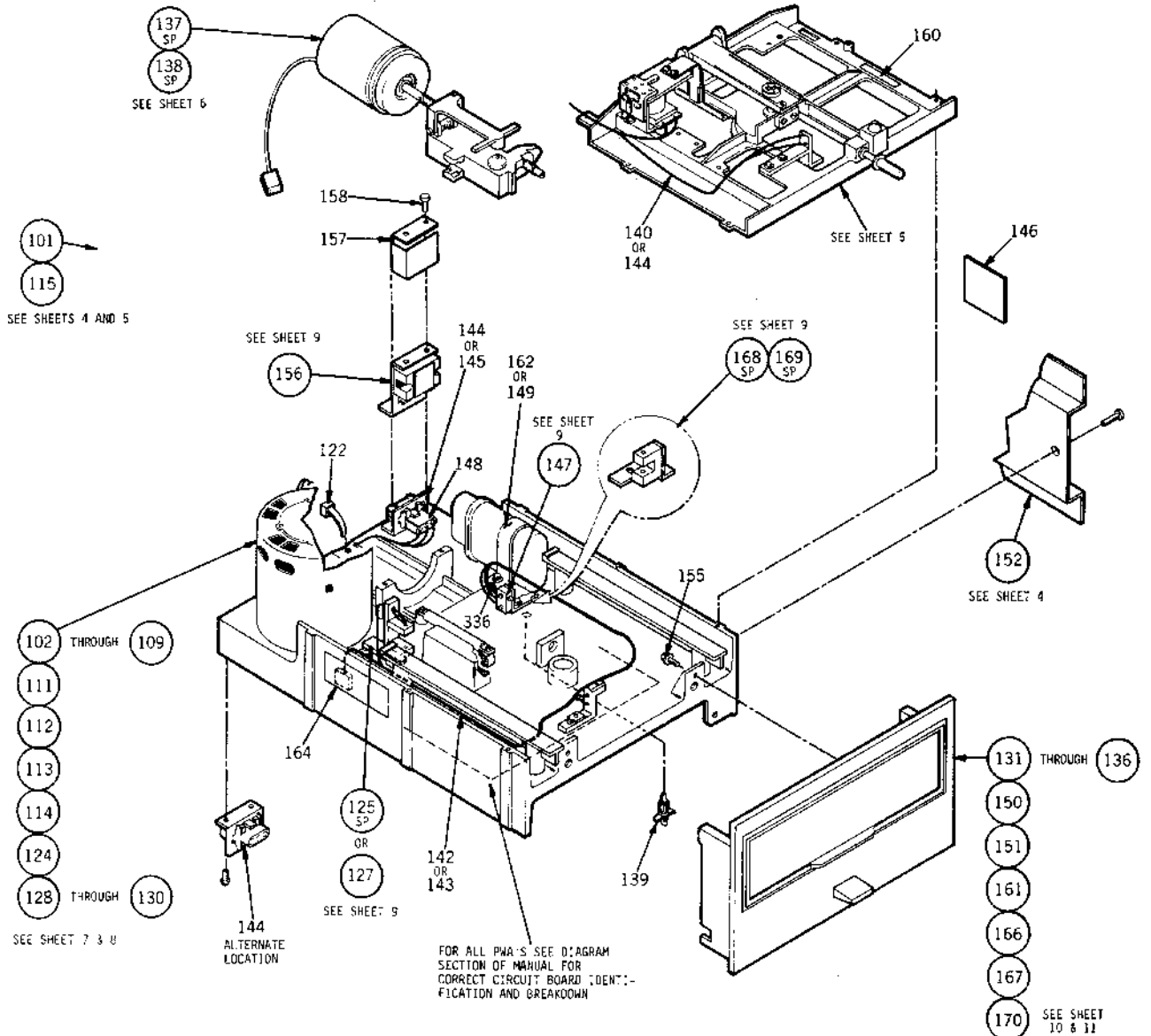

FIGURE 8-1. TOP MECHANICAL ASSEMBLY

ITEM IDENT NO	DESCRIPTION	WHERE USED
101	83458201	CHASSIS ASM-COMMON PARTS TMA
115	75891430	CHASSIS ASM-COMMON PARTS TMA
152	77832691	MOUNTING KIT TMA
153	92602001	CLAMP 101 115
178	10125801	WASHERS SPR LOCK 101 115
180	75293203	BELT-FLAT 101 115
183	75770732	CLIP-PUSH IN 101 115
186	10125803	WASHERS SPR LOCK 101 115
187	10125605	WASHERS PLAIN 101 115
188	77832145	LABEL IDENT 101 115
191	77613697	BEARING FLANGED 101 115
192	93529005	WASHER-SPRING WAVE 101 115
196	16402506	CLAMP CABLE 101 115
199	69000403	SCREW BIND HEAD 101 115
202	10126222	SCREW HEX SOC HD 101 115
205	93592086	SCR HEX SELF TAP 101 115
208	92602003	CLAMP, CABLE-NYLON 101 115
209	10126214	SCR HEX SOC HD CAP 101 115
210	83427900	PLATE-NUT 101 115
218	75887456	CARRIAGE STOP 101 115
219	93592488	SCREW 101 115
255	10127131	SCREW 152
256	10125805	LOCK WASHER 152
301	77830975	ADAPTER 152
336	93592160	SCREW, SELF TAP 101 115
339	10126401	STAR LOCK WASHER 101 115
340	75731302	ELECTRICAL SYMBOL 101 115
342	77594800	DECAL 152
360	75886086	BASE-MECHANISM, DIE 101
361	83403501	SPINDLE 101 115
362	75747000	SPACER BEARING 101 115
363	75745200	PULLEY-SPINDLE 101 115
364	75886087	BASE-MECHANISM, DIE 115
365	83461800	CLAMP, STRPPER MOTDR 101 115
366	75292400	GUIDE-CARRIAGE 101 115
367	83461801	STEPPER MOTOR CLAMP 115
374	94277400	TIE STRAP 101
377	93592486	SCREW 101 115
388	10125603	WASHER 101 115

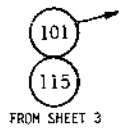
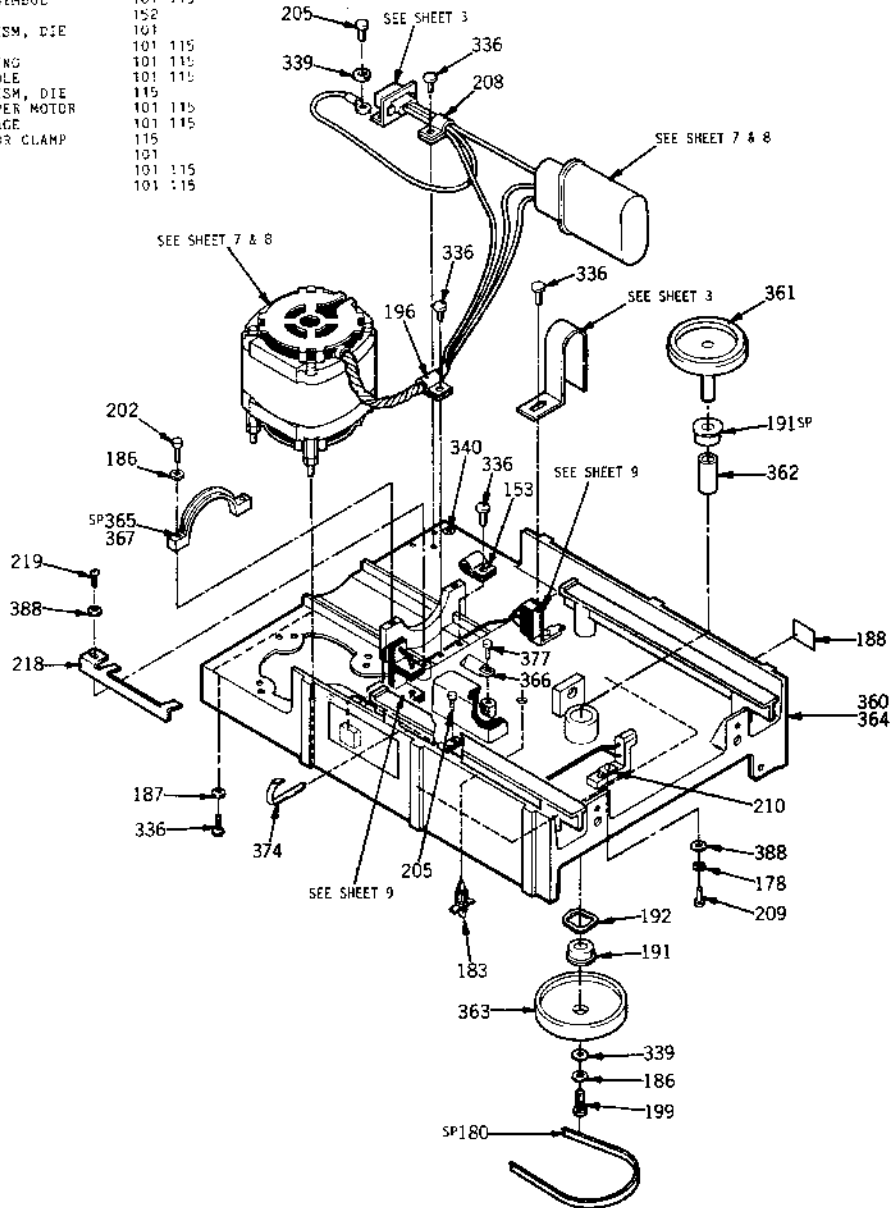
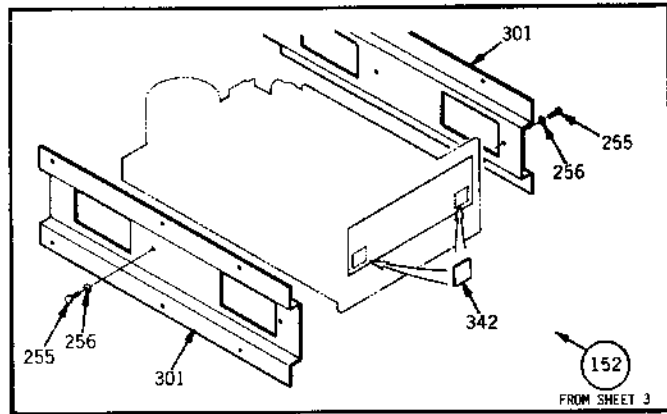
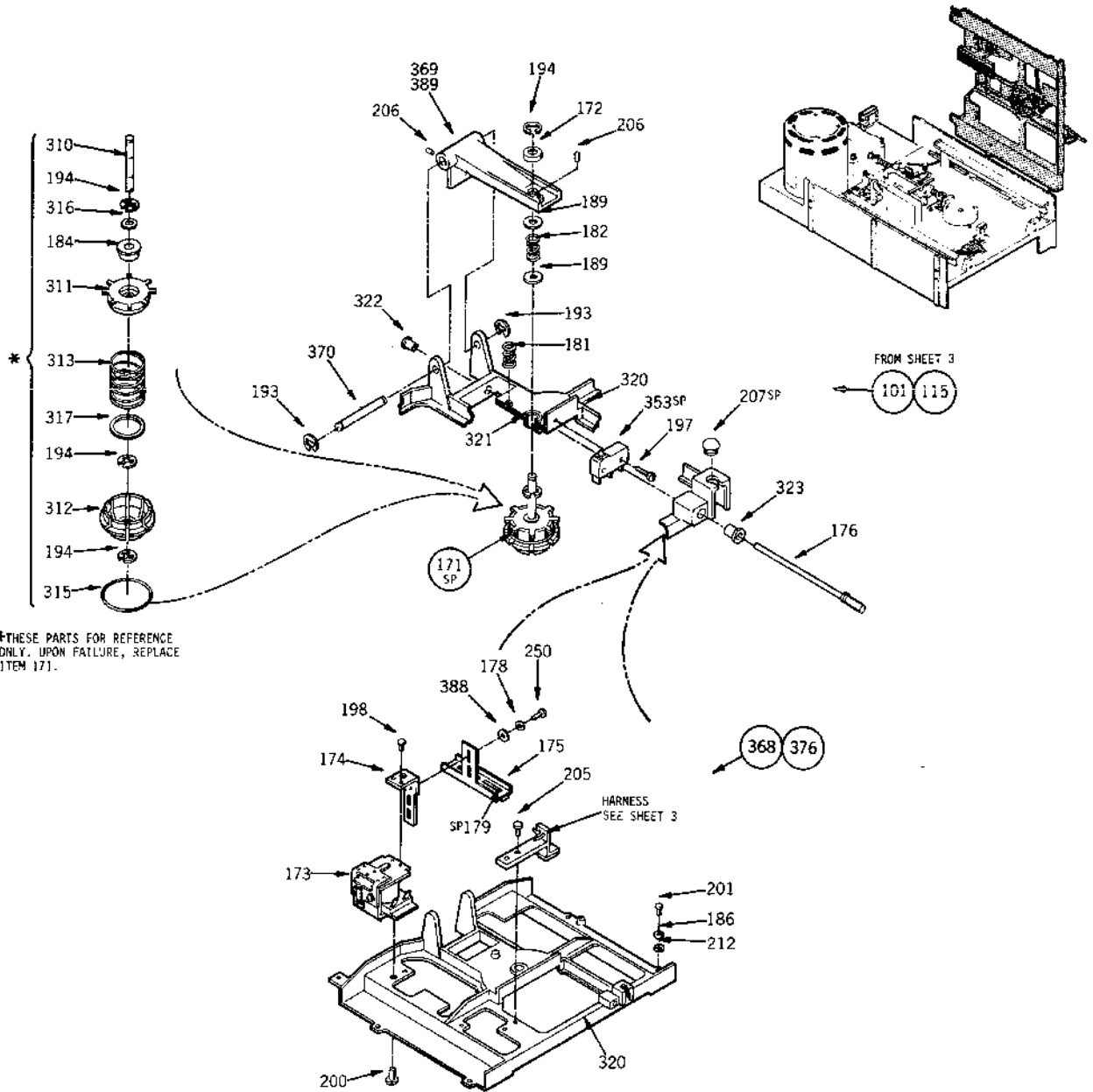

FIGURE 8-2. FDD COMMON PARTS (SHEET 1 OF 2)



*THESE PARTS FOR REFERENCE ONLY. UPON FAILURE, REPLACE ITEM 171.

ITEM IDENT NO	DESCRIPTION	WHERE USED	ITEM IDENT NO	DESCRIPTION	WHERE USED
101 83456201	CHASSIS ASM-COMMON PARTS	TMA	206 93820246	SCREW-SELF LOCKING	101 115
115 75691460	CHASSIS ASM-COMMON PARTS	TMA	207 83411202	BUMPER DOOR	101 115
171 83402101	CONE ASM	101 115	212 54279109	FLAT WASHER	101 115
172 75273200	BUSHING	101 115	250 93592482	SCR HEX HD	101 115
173 75747202	SOLENOID	101 115	310 75790803	SHAFT	171
174 77854331	EXTENSION ARMATURE	101 115	311 83426400	EXPANDER-CONE	171
175 77834326	TAIL ARMATURE	101 115	312 77830481	CONE-DISK LOAD	171
176 75669163	PUSH ROD ASSY	101 115	313 83402200	SPRING CONE	171
178 10125801	WASHERS SPR LOCK	101 115	315 85409701	SPRING-GARTER	171
179 77830732	FOAM PAD	101 115	316 94047069	WASHER	171
181 75891000	SPRING-COMPRESSION	101 115	317 94047070	WASHER	171
182 75292677	SPRING-COMPRESSION	101 115	320 75312011	SUPPORT DIE CAST MACHINED	368
184 77613696	BALL BEARING	171	321 75292807	BEARING-CYLINDRICAL	368
186 10125823	WASHERS SPR LOCK	101 115	322 75813201	BUSHING, PUSH ROD MOLDED	368
189 77835200	WASHER, NYLON	101 115	323 75813202	BUSHING, PUSH ROD MOLDED	368
193 92033037	RING RETAINING	115	353 75724401	ACTUATOR SWITCH	101 115
194 92033038	RETAINING RING	101 115	368 75612021	SUPPORT-ASSEMBLED	101
194 92033038	RETAINING RING	101 115	369 83402803	ARM-DISK LOAD	101
197 09060035	SCREW BIND HEAD	101 115	370 75273000	PIN DISK LOAD ARM	101 115
196 09060032	SCREW BIND HEAD	101 115	376 75812022	SUPPORT-ASSEMBLED	115
200 09060030	SCREW BIND HEAD	101 115	388 10125603	WASHER	101 115
201 10126219	SCR HEX 50C HD CAP	101 115	389 83402804	ARM-DISK LOAD	115
205 93592086	SCR HEX SELF TAP	101 115			

FIGURE 8-2. FDD COMMON PARTS (SHEET 2 OF 2)

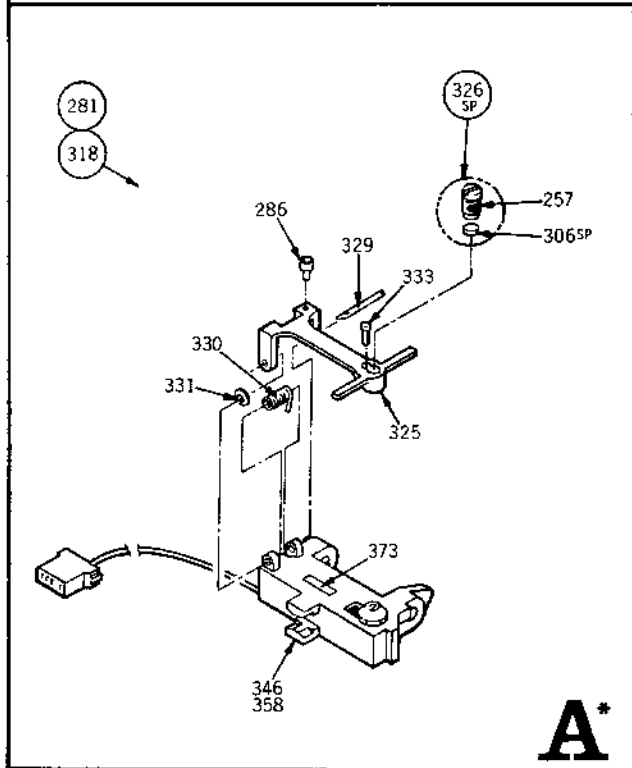
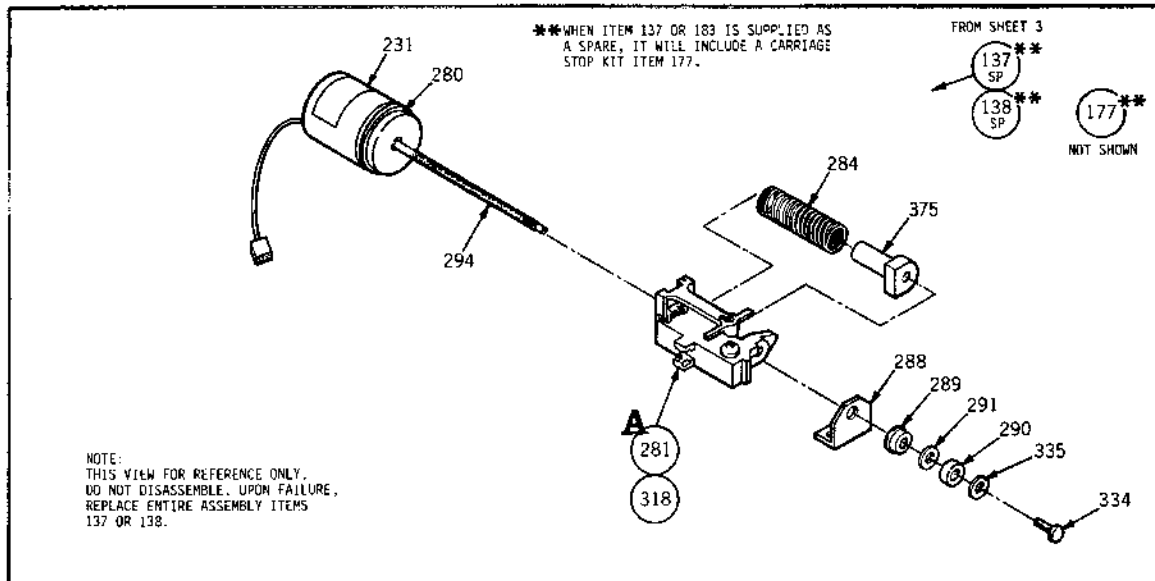

ITEM IDENT NO	DESCRIPTION	WHERE USED	
137	75791510	ACTUATOR ASM	TWA
138	75791511	ACTUATOR ASM	TWA
177	75882711	CARRIAGE STOP KIT	137 138
231	75790000	CAUTION LABEL	137 138
257	83460400	HOLDER PAD	326
280	75747801	STEPPER MOTOR ASM	137 138
281	77839902	CARRIAGE ASM	137
284	77594000	SPRING-CARRIAGE	137 138
286	10126209	SCR-SOC HP CAP	281 318
288	75813000	RETAINER-BEARING	137 138
289	77613699	BEARING FLANGED	137 138
290	94217207	BFG BALL-EXT INNER R	137 138
291	93529001	WASHER-SPRING WAVE	137 138
294	77832455	LUBRICANT	137 138
306	83460701	PAD HEAD LOAD	326
318	77839901	CARRIAGE ASSY	138
325	77603100	ARM-HEAD LOAD	281 318
326	77830482	HOLDER-PAD ASSY	281 318
329	77830998	PIN CARRIAGE	281 318
330	77830999	SPRING TORSION	281 318
331	94047068	WASHER, SPECIAL	281 318
333	10127310	SCREW SLOTTED	281 318
334	10125001	SCREW HEX HD	137 138
335	94047000	WASHER	137 138
346	83426204	CARRIAGE HEAD ASSY	281
358	83426205	CARRIAGE HEAD ASSY	318
373	77835304	LABEL	324 358
375	83427303	NUT CARRIAGE	137 138

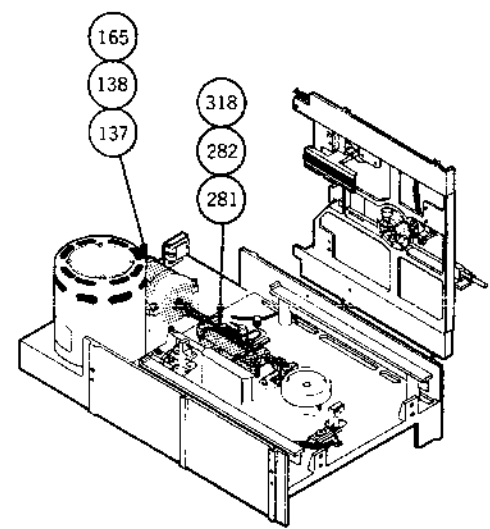
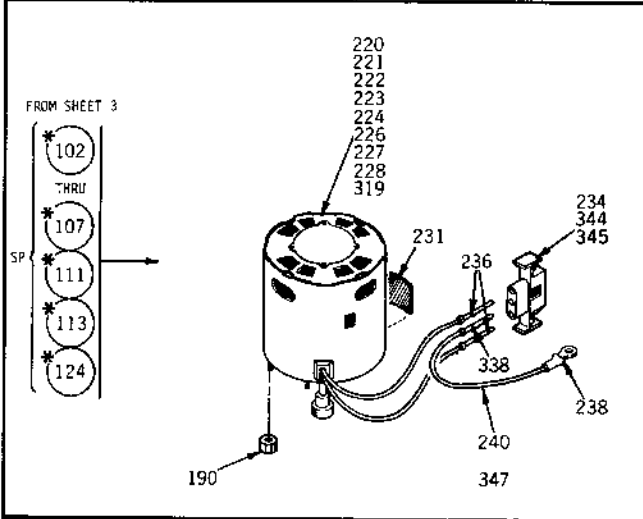
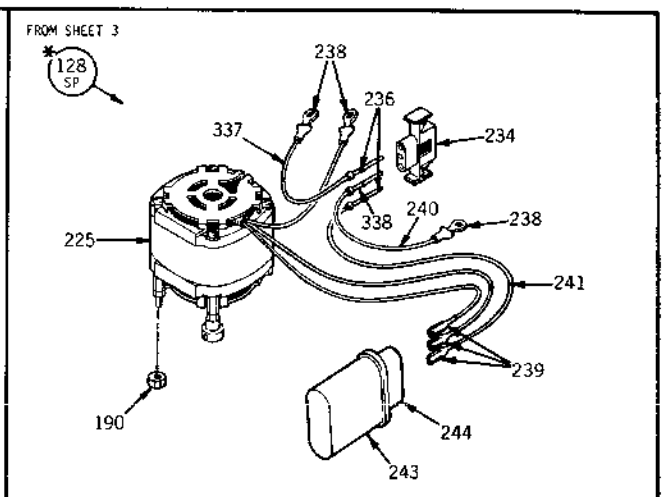
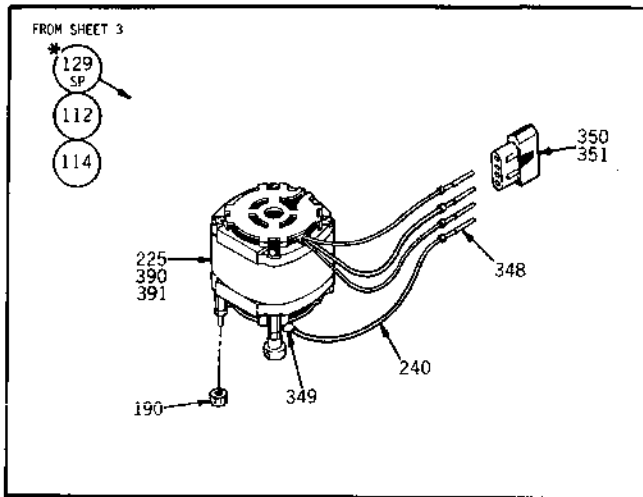
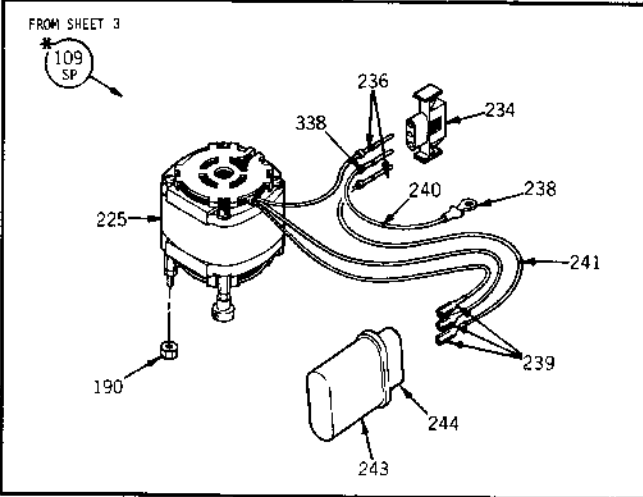

FIGURE 8-3. ACTUATOR AND CARRIAGE ASSEMBLIES



ITEM	IDENT	NO	DESCRIPTION	WHERE USED
102	75291920		DRIVE MOTOR ASM 60 HZ	TMA
103	75291923		DRIVE MOTOR ASM 50 HZ	TMA
104	75291926		DRIVE MOTOR ASM 60 HZ	TMA
105	75291927		DRIVE MOTOR ASM 50 HZ	TMA
106	75291928		DRIVE MOTOR ASM 50 HZ	TMA
107	75291925		DRIVE MOTOR ASM 50 HZ	TMA
108	75888178		DRIVE MOTOR ASM 50 HZ	TMA
109	75881775		DRIVE MOTOR ASM 60 HZ	TMA
111	75291921		DRIVE MOTOR ASM 60 HZ	TMA
112	77834213		DRIVE MOTOR ASSY	TMA
113	75291924		DRIVE MOTOR ASM 60 HZ	TMA
114	77834214		DRIVE MOTOR ASSY	TMA
124	75291902		DRIVE MOTOR ASM 50 HZ	TMA
128	75881779		DRIVE MOTOR ASM 60 HZ	TMA
129	75881780		DRIVE MOTOR ASM 60 HZ	TMA
130	75888181		DRIVE MOTOR ASM 50 HZ	TMA
190	94217702		NUT-SELF LOCK, STL	102-130
220	77833503		MOTOR PULLEY ASSY	111
221	77833504		MOTOR PULLEY ASSY	103
222	77833519		MOTOR PULLEY ASSY	107
223	77833520		MOTOR PULLEY ASSY	105
224	77833507		MOTOR PULLEY ASSY	106
225	75881760		MOTOR PULLEY ASSY	109 128
225	75881760		MOTOR PULLEY ASSY	129
226	77833502		MOTOR PULLEY ASSY	102
227	77833501		MOTOR PULLEY ASSY	124
228	77833506		MOTOR PULLEY ASSY	104
231	75790000		CAUTION LABEL	113
231	75790000		CAUTION LABEL	124 139
231	75790000		CAUTION LABEL	102-107
231	75790000		CAUTION LABEL	111 112
232	77833505		MOTOR PULLEY ASSY	113
234	83435402		CONNECTOR	128
234	83435402		CONNECTOR	111 113
234	83435402		CONNECTOR	102-110
236	83435501		CONTACT PIN	102-128
238	51797233		TERMINAL	102-128
239	52121106		TERMINAL	128 109
240	15003254		WIRE (YELLOW)	102-128
240	15003254		WIRE (YELLOW)	129
241	15003309		WIRE	106-109
241	15003309		WIRE	128
243	75738405		CAPACITOR	109
244	75725000		CAPACITOR BOOT	128 109
319	77833505		MOTOR PULLEY ASSY	113
337	93464000		WIRE BLACK	114 128
338	83435511		CONTACT PIN	102-125
344	75724543		CONNECTOR PANEL MTC	124
345	75724586		CONNECTOR PANEL MTC	124
347	93464555		WIRE 16 GRN	124
348	75724587		CONTACT PIN	129
349	51797214		LUG TERM RING CRIMP	112 119
349	51797214		LUG TERM RING CRIMP	129
350	75724569		CONNECTOR PANEL MTC	112 114
350	75724569		CONNECTOR PANEL MTC	129
351	75724585		CONNECTOR PANEL	129
390	77833527		PULLEY MOTOR ASSY	114
391	77833525		PULLEY MOTOR ASSY	112



*RECOMMENDED FIELD REPLACEMENT LEVEL.
ALL OTHER PARTS SHOULD BE CONSIDERED
REFERENCE DATA ONLY.

FIGURE 8-4, DRIVE MOTOR ASSEMBLY (SHEET 1 OF 2)

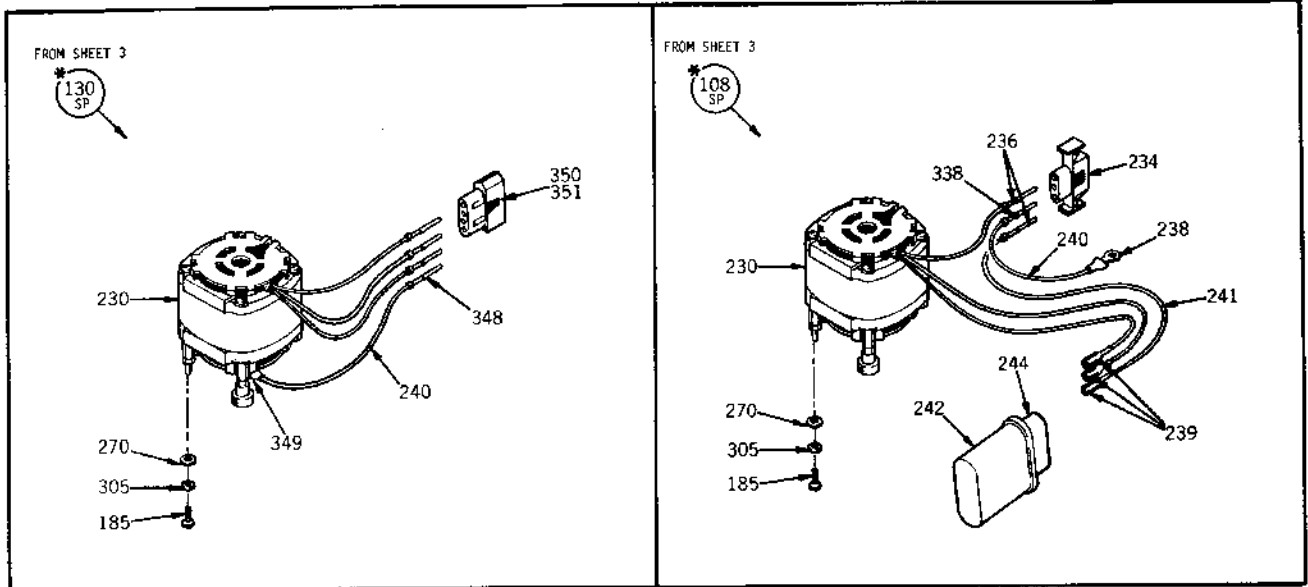

ITEM IDENT NO	DESCRIPTION	WHERE USED
165 1012723	SCREW	108 130
229 75881768	MOTOR PULLEY ASSY	108
230 75881762	MOTOR PULLEY ASSY	130
234 83435402	CONNECTOR	108
236 83435501	CONTACT PIN	108
238 51797233	TERMINAL	108
239 62121108	TERMINAL	108
240 15003254	WIRE (YELLOW)	108 130
241 15003309	WIRE	108
242 75736483	CAPACITOR	108
244 75772503	CAPACITOR BOOT	108
270 16125606	WASHER	108 130
305 16125804	LK WASHER	108 130
338 83435511	CONTACT PIN	108
348 75724587	CONTACT PIN	130
349 51797214	CONTACT PIN	112 114
350 75724569	LLS TERM RING CRIMP	130
351 75724565	CONNECTOR PANEL MTC	130

*RECOMMENDED FIELD REPLACEMENT LEVEL.
 ALL OTHER PARTS SHOULD BE CONSIDERED
 REFERENCE DATA ONLY.

FIGURE 8-4. DRIVE MOTOR ASSEMBLY (SHEET 2 OF 2)

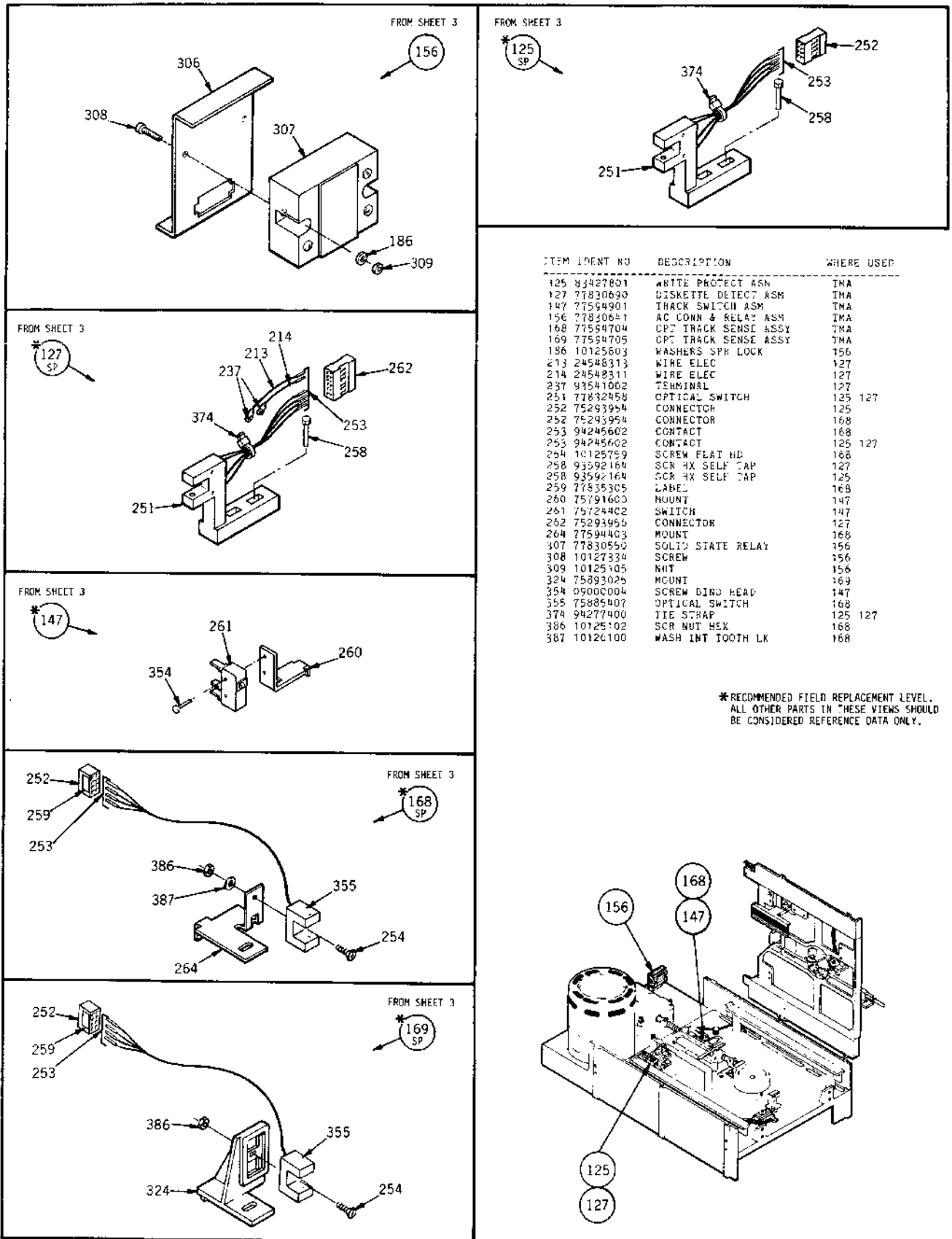

ITEM	QTY	NO	DESCRIPTION	WHERE USED
125		8427801	WHITE PROTECT ASM	TMA
127		77830690	DISKETTE DETECT ASM	TMA
147		77594901	TRACK SWITCH ASM	TMA
156		77840641	AC CONN & RELAY ASM	TMA
168		77594704	CPT TRACK SENSE ASSY	TMA
169		77594705	CPT TRACK SENSE ASSY	TMA
186		10125603	WASHERS SPR LOCK	156
213		24548313	WIRE ELEC	127
214		24548311	WIRE ELEC	127
237		93541002	TERMINAL	127
251		77832458	OPTICAL SWITCH	125 127
252		75293954	CONNECTOR	125
253		75293954	CONNECTOR	168
253		94245602	CONTACT	168
253		94245602	CONTACT	125 127
254		10125759	SCREW FLAT HD	168
258		93592164	SCR HX SELF TAP	127
258		93592164	SCR HX SELF TAP	125
259		77835305	LABEL	168
260		75791603	MOUNT	147
261		75724402	SWITCH	147
262		75293955	CONNECTOR	127
264		77594403	MOUNT	168
307		77830550	SOLID STATE RELAY	156
308		10127334	SCREW	156
309		10125105	NUT	156
324		75893025	MOUNT	169
354		09000004	SCREW DING HEAD	147
355		75885407	OPTICAL SWITCH	168
374		94277400	TIE STRAP	125 127
386		10125102	SCR NUT HEX	168
387		10126100	WASH INT TOOTH LK	168

*RECOMMENDED FIELD REPLACEMENT LEVEL.
ALL OTHER PARTS IN THESE VIEWS SHOULD
BE CONSIDERED REFERENCE DATA ONLY.

FIGURE 8-5. MISCELLANEOUS SUB-ASSEMBLIES

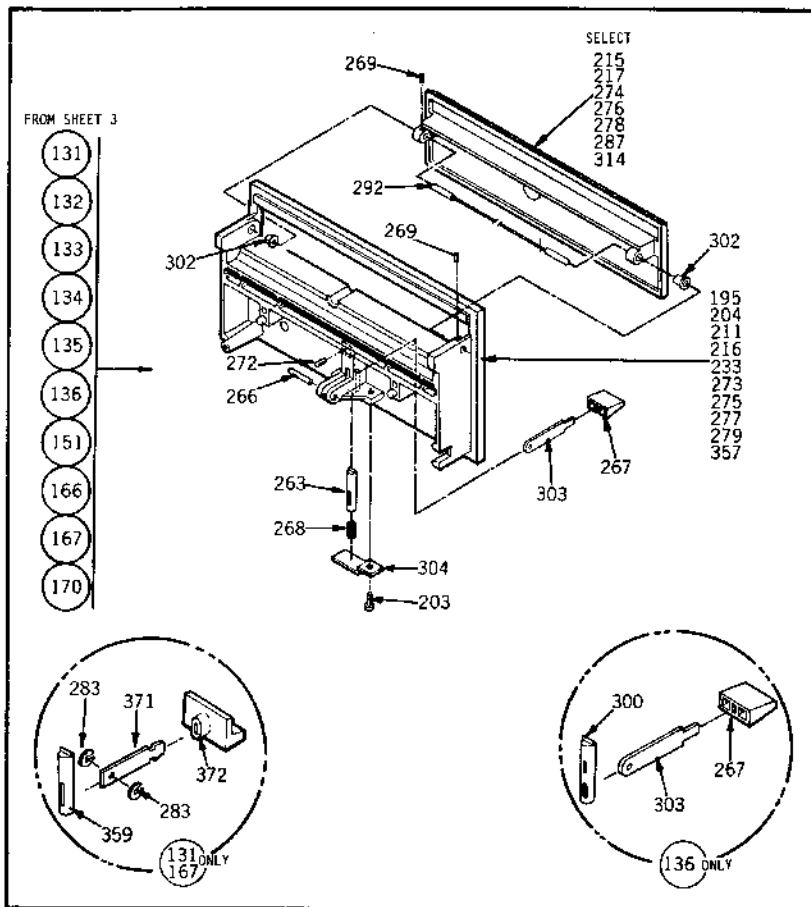

ITEM IDENT NO	DESCRIPTION	WHERE USED	
122	94277416	STRAP, CABLE TIE	161
131	83401806	FRONT PANEL ASM	TMA
132	83401801	FRONT PANEL ASM	TMA
133	83401802	FRONT PANEL ASM	TMA
134	83401803	FRONT PANEL ASM	TMA
135	83401804	FRONT PANEL ASM	TMA
136	83401805	FRONT PANEL ASM	TMA
151	83401809	FRONT PANEL ASM	TMA
161	77834543	FRONT PANEL ASSY	TMA
166	83401812	FRONT PANEL ASSY	TMA
167	83401811	FRONT PANEL ASSY	TMA
170	83401808	FRONT PANEL ASSY	TMA
195	83426624	PANEL FRONT FIN BLK	132
203	93592162	SCR HX WASHER SLF TA	166-167
203	93592162	SCR HX WASHER SLF TA	161-170
203	93592162	SCR HX WASHER SLF TA	131-136
204	75898043	PANEL, FRONT, FIN BLK	151
211	83426626	PANEL FRONT FIN BLU	170
215	75812126	DOOR FINISHED BLU	170
216	77832411	FRONT PANEL (GRAY)	167
217	75812126	DOOR (GRAY)	167
233	83426628	FRONT PANEL (BLK)	166
245	77835131	SOLENOID BRKT	295
246	77834212	SOLENOID	295
247	95520103	PIN ROLL	295
248	75806507	WASHER	295
249	77834323	SPRING	295
263	83402301	LATCH-DOOR INJEC MOL	132-135
263	83402301	LATCH-DOOR INJEC MOL	166-170
265	77834318	LEVER-DOOR	161
266	92096099	PIN-GROOVED	166-167
266	92096099	PIN-GROOVED	161-170
266	92096099	PIN-GROOVED	131-136
267	75292700	KNOB-LEVER	170
267	75292700	KNOB-LEVER	132-136
268	83401200	SPRING-LATCH	161-170
268	83401200	SPRING-LATCH	131-136
268	83401200	SPRING-LATCH	166-167
269	83413406	SCR SET SOC HD 6-32	131-136
269	83413406	SCR SET SOC HD 6-32	166-167
269	83413406	SCR SET SOC HD 6-32	161-170
271	75292701	KNOB-LEVER	161
272	83413404	SCREW-SELF LOCKING	131-136
272	83413404	SCREW-SELF LOCKING	150
272	83413404	SCREW-SELF LOCKING	166-167

ITEM IDENT NO	DESCRIPTION	WHERE USED	
273	83426621	PANEL FRONT, BLACK HW	133
274	75812121	DOOR, FINISHED, PA-BLK	133
275	83426622	PANEL FRONT, WHITE HW	134
276	75812122	DOOR, FINISHED, PA-WHT	134
277	83426623	PANEL FRONT, FIN BLUE	135
278	75812123	DOOR, FINISHED, PA-BLU	135
279	83401810	FRONT PANEL FINISHED	136
283	75881371	SHIP	131-167
285	75898352	DOOR LEVER SPRING	161
287	75812124	DOOR FINISHED BLACK	131-161
287	75812124	DOOR FINISHED BLACK	132-136
292	83403202	BAR TORSION DOOR	166-167
292	83403202	BAR TORSION DOOR	131-136
292	83403202	BAR TORSION DOOR	161-170
293	83461111	FRONT PANEL	161
295	77835133	DOOR LK ASSY	161
296	91976207	SCREW	161
297	77833702	HARNES DR LK	161
298	75810703	RETAINING RING	161
299	75810701	DIODE LIGHT	161
300	83461200	LATCH DOOR	136
302	83401500	BUSHING-DOOR INJECT	161-170
302	83401500	BUSHING-DOOR INJECT	131-136
302	83401500	BUSHING-DOOR INJECT	166-167
303	75746000	LEVER-DOOR	132-136
303	75746000	LEVER-DOOR	170-166
304	75746800	BRACKET LATCH	161-170
304	75746800	BRACKET LATCH	166-167
304	75746800	BRACKET LATCH	131-136
314	75812125	DOOR (BLK)	166
327	10127321	SCR PAN HD	295
328	77643443	LEVER KNOB	166
332	75869161	LATCH DOOR	161
357	77832410	PANEL FRONT BLK-BARR	131
359	77830977	LATCH DOOR	131-167
371	75881370	LEVER DOOR	131-167
372	77832119	ELECTR LATCH	131-167
378	95562300	ANCHOR CABLE TIE	161
375	77251132	SPACER BRKT	295

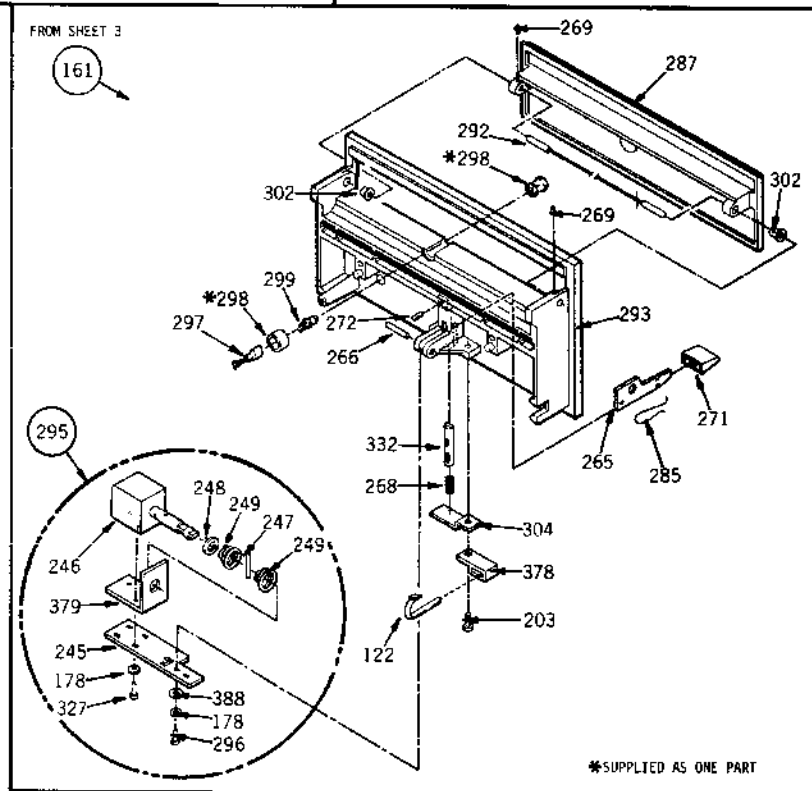
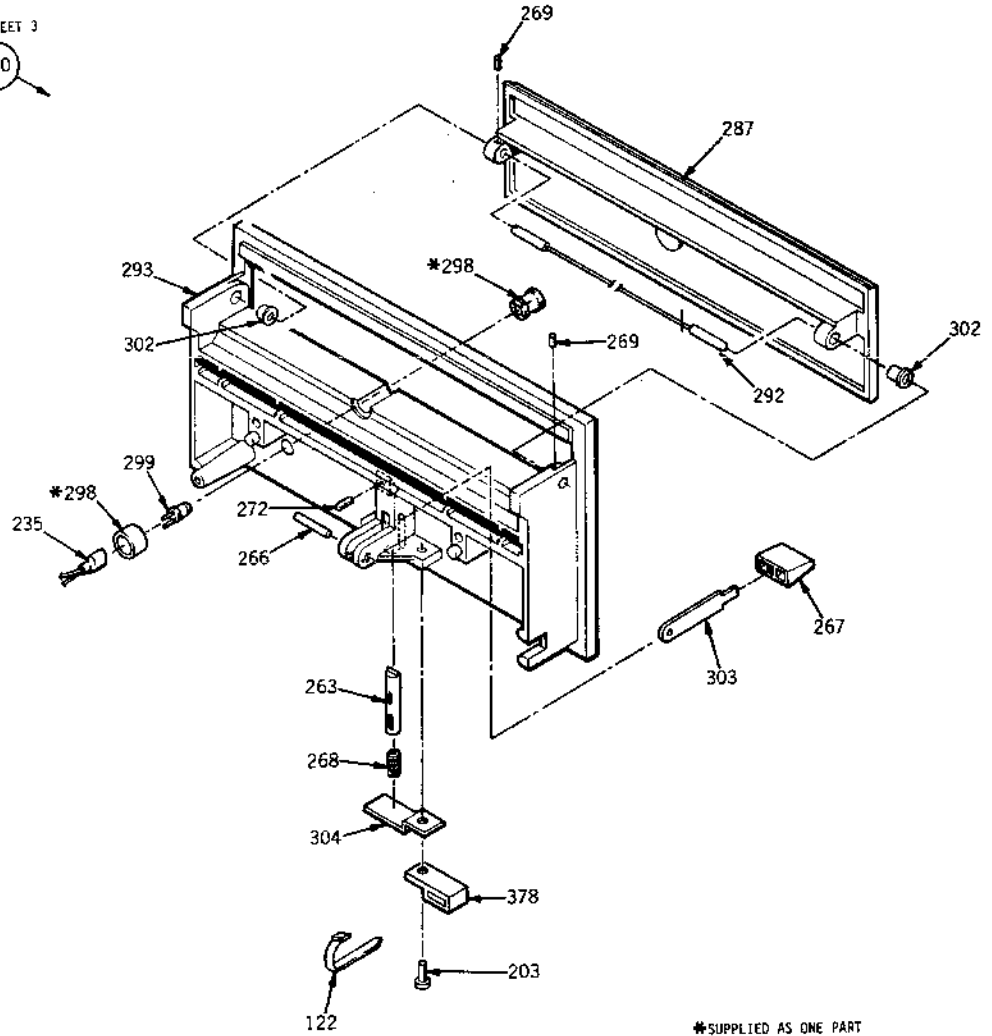

FIGURE 8-6. FRONT PANEL ASSEMBLY (SHEET 1 OF 2)

FROM SHEET 3

150



*SUPPLIED AS ONE PART

ITEM IDENT NO	DESCRIPTION	WHERE USED
122 94277416	STRAP, CABLE TIE	150
150 75898080	FRONT PANEL ASM	TMA
203 93592162	SCR NX WASHER SLF TA	150
235 75898086	HARNESSES	150
263 83402301	LATCH-LOOP INJEC MOL	150
266 92096399	PIN-GROOVED	150
267 75292700	KNOCK-LEVER	150
268 83401200	SPRING-LATCH	150
269 63413406	SCR SET SOC HD 6-32	150
272 83413404	SCREW-SELF LOCKING	381 179
287 75812124	DOOR FINISHED BLACK	150
292 83403202	EAR TORISON DOOR	150
293 83461111	FRONT PANEL	150
299 75810703	RETAINING RING	150
299 75810701	DIGDE LIGHT	150
302 83401500	BUSHING-DOOR INJECT	150
303 75746000	LEVER-DOOR	150
304 75746800	BRACKET LATCH	150
378 95862300	ANCHOR CABLE TIE	150

FIGURE 8-6. FRONT PANEL ASSEMBLY (SHEET 2 OF 2)

8.6 PARTS LIST INSTRUCTIONS

8.6.1 ILLUSTRATION PARTS LISTS

The parts list for each illustration is an extract from the Top-Down Assembly/Component Parts list and contains only those parts depicted. Refer to paragraph 8.6.2 for explanation of parts list.

8.6.2 TOP-DOWN ASSEMBLY/COMPONENT PARTS LIST

- a. Starts at TMA level and lists all parts in Item Number sequence.
- b. Correlates Item numbers with part Identification numbers and the Description of each.
- c. Identifies where each part is used (where used column) within the device by listing the item number(s) of the next higher assembly.

NOTE

Where used data for Figure 8-1 is labeled TMA.
Refer to Table 8-1 for correct application of parts (refer to paragraph 8.4).

- d. Defines the location of each part by listing the sheet number(s) where depicted.

NOTE

The same part may be used in any number of assemblies or sheet locations.

8.6.3 CROSS REFERENCE INDEX

- a. Lists all parts in numeric sequence (by Identification Number).
- b. In conjunction with the referenced sheet number (third column) and illustrations defines the physical location of each item identified.

8.6.4 SHEET NUMBER REFERENCING

Sheet number references of Parts Lists and Illustrations refers to sheet locations in this section. Example: Sheet reference 3 represents sheet 8-3, sheet 4 represents sheet 8-4, etc.

8.7 SPARE PARTS (SP)

This Illustrated Parts Breakdown is complete to the extent that all parts and assemblies are depicted and identified. Replacement part availability depends on the materials and provisioning operation of the supplier.

To assist the service representative in selecting replacement parts with minimum requisitioning lead times, engineering recommended spare parts which reflect the intended service level of the device are identified with the letters SP adjacent to the item number on the face of each illustration. Replacement non-spared items will require longer requisitioning lead times.

TOP-DOWN ASSEMBLY/COMPONENT PARTS LIST

ITEM IDENT NO					DESCRIPTION					WHERE USED SHEET				
101	83408201	CHASSIS ASM-COMMON PARTS	TMA	S3	170	83401808	FRONT PANEL ASSY	TMA	S10					
101	83458201	CHASSIS ASM-COMMON PARTS	TMA	S4	171	83402101	CONE ASM	101 115	S5					
101	83458201	CHASSIS ASM-COMMON PARTS	TMA	S5	172	75273200	BUSHING	101 115	S5					
102	75291920	DRIVE MOTOR ASM 60 HZ	TMA	S3	173	75747202	SOLENOID	101 115	S5					
102	75291920	DRIVE MOTOR ASM 60 HZ	TMA	S7	174	77834331	EXTENSION ARMATURE	101 115	S5					
103	75291923	DRIVE MOTOR ASM 50 HZ	TMA	S3	175	77834326	BATL ARMATURE	101 115	S5					
103	75291923	DRIVE MOTOR ASM 50 HZ	TMA	S7	176	75885163	PUSH ROD ASSY	101 115	S5					
104	75291926	DRIVE MOTOR ASM 60 HZ	TMA	S3	177	75882711	CARRIAGE STOP KIT	137 138	S6					
104	75291926	DRIVE MOTOR ASM 60 HZ	TMA	S7	178	10125601	WASHERS SPR LOCK	101 115	S4					
105	75291927	DRIVE MOTOR ASM 50 HZ	TMA	S3	178	10125801	WASHERS SFR LOCK	101 115	S5					
105	75291927	DRIVE MOTOR ASM 50 HZ	TMA	S7	179	77630732	FOAM PAD	101 115	S5					
106	75291928	DRIVE MOTOR ASM 50 HZ	TMA	S7	180	75293203	BELT-FLAT	101 115	S4					
107	75291928	DRIVE MOTOR ASM 50 HZ	TMA	S3	181	75891000	SPRING-COMPRESSION	101 115	S5					
107	75291928	DRIVE MOTOR ASM 50 HZ	TMA	S7	182	75292517	SPRING-COMPRESSION	101 115	S5					
108	75888178	DRIVE MOTOR ASM 50 HZ	TMA	S3	183	75774732	CLIP-PUSH IN	101 115	S4					
108	75888178	DRIVE MOTOR ASM 50 HZ	TMA	S7	184	77613096	BALL BEARING	171	S5					
108	75888178	DRIVE MOTOR ASM 50 HZ	TMA	S3	185	10127123	SCREW	108 130	S8					
109	75881775	DRIVE MOTOR ASM 60 HZ	TMA	S7	186	10125803	WASHERS SPR LOCK	101 115	S4					
109	75881775	DRIVE MOTOR ASM 60 HZ	TMA	S3	186	10125603	WASHERS SPR LOCK	101 115	S5					
111	75291921	DRIVE MOTOR ASM 60 HZ	TMA	S3	186	10125803	WASHERS SPR LOCK	156	S9					
111	75291921	DRIVE MOTOR ASM 60 HZ	TMA	S7	187	10125605	WASHERS PLAIN	101 115	S4					
112	77834213	DRIVE MOTOR ASSY	TMA	S3	187	77832745	LABEL IDENT	101 115	S4					
112	77834213	DRIVE MOTOR ASSY	TMA	S7	188	77835200	WASHER, NYLON	101 115	S5					
113	75291924	DRIVE MOTOR ASM 60 HZ	TMA	S3	189	77835200	WIT-SELF LOCK, STL B	102-130	S7					
113	75291924	DRIVE MOTOR ASM 60 HZ	TMA	S7	190	94271702	BEARING FLANGED	101 115	S5					
114	77834214	DRIVE MOTOR ASSY	TMA	S3	191	77613657	WASHER-SPRING WAVE	101 115	S5					
114	77834214	DRIVE MOTOR ASSY	TMA	S7	192	93529005	RING RETAINING	101 115	S4					
115	75891480	CHASSIS ASM-COMMON PARTS	TMA	S3	193	92043037	RETAINING RING	101 171	S5					
115	75891480	CHASSIS ASM-COMMON PARTS	TMA	S4	194	92033038	RETAINING RING	115	S5					
115	75891480	CHASSIS ASM-COMMON PARTS	TMA	S5	195	83426624	PANEL FRONT FIN BLK	132	S10					
122	94277416	STRAP, CABLE TIE	TMA	S3	196	16402506	CLAMP CABLE	101 115	S4					
122	94277416	STRAP, CABLE TIE	161	S10	197	09000005	SCREW BIND HEAD	101 115	S5					
122	94277416	STRAP, CABLE TIE	150	S11	198	09000202	SCREW BIND HEAD	101 115	S5					
124	75291902	DRIVE MOTOR ASM 50 HZ	TMA	S3	199	09000403	SCREW BIND HEAD	101 115	S4					
124	75291902	DRIVE MOTOR ASM 50 HZ	TMA	S7	200	09000504	SCREW BIND HEAD	101 115	S5					
125	83427801	WRITE PROTECT ASM	TMA	S3	201	10126219	SCR HEX SOC HD CAP	101 115	S5					
125	83427801	WRITE PROTECT ASM	TMA	S9	202	10126222	SCREW HEX SOC HD	101 115	S4					
127	77830690	DISKETTE DETECT ASM	TMA	S3	203	93592162	SCR HX WASHER SLF TA	131-136	S10					
127	77830690	DISKETTE DETECT ASM	TMA	S9	203	93592162	SCR HX WASHER SLF TA	161 170	S10					
128	75881779	DRIVE MOTOR ASM 60 HZ	TMA	S3	203	93592162	SCR HX WASHER SLF TA	166 167	S10					
128	75881779	DRIVE MOTOR ASM 60 HZ	TMA	S7	204	75898043	SCR HX WASHER SLF TA	150	S11					
129	75881780	DRIVE MOTOR ASM 60 HZ	TMA	S3	205	93592086	PANEL, FRONT, FIN BLK	151	S10					
129	75881780	DRIVE MOTOR ASM 60 HZ	TMA	S7	205	93592086	SCR HEX SELF TAP	101 115	S4					
150	75888181	DRIVE MOTOR ASM 50 HZ	TMA	S3	205	93592086	SCR HEX SELF TAP	101 115	S5					
150	75888181	DRIVE MOTOR ASM 50 HZ	TMA	S7	206	93820248	SCREW-SELF LOCKING	101 115	S5					
131	83401806	FRONT PANEL ASM	TMA	S3	207	83411202	BUMPER DOOR	101 115	S5					
131	83401806	FRONT PANEL ASM	TMA	S10	208	92602003	CLAMP, CABLE-NYLON	101 115	S4					
132	83401801	FRONT PANEL ASM	TMA	S3	209	10126214	SCR HEX SOC HD CAP	101 115	S4					
132	83401801	FRONT PANEL ASM	TMA	S10	210	83427900	PLATE-NUT	101 115	S4					
133	83401802	FRONT PANEL ASM	TMA	S3	211	83426626	PANEL FRONT FIN BLU	170	S10					
133	83401802	FRONT PANEL ASM	TMA	S10	212	94279109	FLAT WASHER	101 115	S5					
134	83401803	FRONT PANEL ASM	TMA	S3	213	24548313	WIRE ELEC	127	S9					
134	83401803	FRONT PANEL ASM	TMA	S10	214	24548311	WIRE ELEC	127	S9					
135	83401804	FRONT PANEL ASM	TMA	S3	215	75812126	DOOR FINISHED BLU	170	S10					
135	83401804	FRONT PANEL ASM	TMA	S10	216	77832411	FRONT PANEL (GRAY)	167	S10					
136	83401805	FRONT PANEL ASM	TMA	S3	217	75812128	DOOR (GRAY)	167	S10					
136	83401805	FRONT PANEL ASM	TMA	S10	218	75882450	CARRIAGE STOP	101 115	S4					
137	75791510	ACTUATOR ASM	TMA	S3	219	93592488	SCREW	101 115	S4					
137	75791510	ACTUATOR ASM	TMA	S6	220	77833503	MOTOR PULLEY ASSY	111	S7					
138	75791511	ACTUATOR ASM	TMA	S3	221	77833504	MOTOR PULLEY ASSY	103	S7					
138	75791511	ACTUATOR ASM	TMA	S6	222	77833519	MOTOR PULLEY ASSY	107	S7					
139	75777436	CLIP-PUSH IN	TMA	S3	223	77833520	MOTOR PULLEY ASSY	105	S7					
140	77830685	UPPER HARNESS ASM	TMA	S3	224	77833507	MOTOR PULLEY ASSY	106	S7					
141	75717301	UPPER HARNESS ASM	TMA	S3	225	75881760	MOTOR PULLEY ASSY	109 128	S7					
142	83403504	LOWER HARNESS ASM	TMA	S3	225	75881760	MOTOR PULLEY ASSY	129	S7					
143	83403503	LOWER HARNESS ASM	TMA	S3	226	77833502	MOTOR PULLEY ASSY	102	S7					
144	83403700	CONNECTOR BRACKET	TMA	S3	227	77833501	MOTOR PULLEY ASSY	124	S7					
145	75272300	CONNECTOR BRACKET	TMA	S3	228	77833506	MOTOR PULLEY ASSY	104	S7					
146	77830538	CSA LABEL	TMA	S3	229	75881768	MOTOR PULLEY ASSY	108	S8					
147	77594901	TRACK SWITCH ASM	TMA	S9	230	75881762	MOTOR PULLEY ASSY	130	S8					
147	77594901	TRACK SWITCH ASM	TMA	S3	231	75790000	CAUTION LABEL	137 138	S6					
148	83461010	AMP CONN KIT	TMA	S3	231	75790000	CAUTION LABEL	124 139	S7					
149	75744702	CAPACITOR BRACKET	TMA	S3	231	75790000	CAUTION LABEL	102-107	S7					
150	75898080	FRONT PANEL ASM	TMA	S3	231	75790000	CAUTION LABEL	111 112	S7					
150	75898080	FRONT PANEL ASM	TMA	S11	231	75790000	CAUTION LABEL	113	S7					
151	83401809	FRONT PANEL ASM	TMA	S3	232	77833505	MOTOR PULLEY ASSY	113	S7					
151	83401809	FRONT PANEL ASM	TMA	S10	232	77833505	MOTOR PULLEY ASSY	113	S7					
152	77832691	MOUNTING KIT	TMA	S3	233	83426628	FRONT PANEL (BLK)	166	S10					
152	77832691	MOUNTING KIT	TMA	S4	234	83435402	CONNECTOR	102-110	S7					
153	92602001	CLAMP	101 115	S4	234	83435402	CONNECTOR	111 113	S7					
153	93592240	SCREW-WASHER	TMA	S3	234	83435402	CONNECTOR	128	S7					
156	77830641	AC CONN & RELAY ASM	TMA	S3	234	83435402	CONNECTOR	108	S8					
156	77830641	AC CONN & RELAY ASM	TMA	S6	235	75898086	HARNESS	150	S11					
157	77830995	COVER	TMA	S3	236	83435401	CONTACT P/N	102-128	S7					
158	17901508	SCREW	TMA	S3	236	83435501	CONTACT P/N	109	S9					
160	77834336	LABEL, FCC	TMA	S3	237	93541002	TERMINAL	127	S9					
161	77834543	FRONT PANEL ASSY	TMA	S3	238	51797233	TERMINAL	102-128	S7					
161	77834543	FRONT PANEL ASSY	TMA	S10	238	51797233	TERMINAL	109	S8					
162	75746701	CAPACITOR BRACKET	TMA	S3	239	62121136	TERMINAL	128 109	S7					
164	77836055	LABEL	TMA	S3	239	62121108	TERMINAL	108	S8					
166	83401812	FRONT PANEL ASSY	TMA	S3	240	15003254	WIRE (YELLOW)	102-128	S7					
166	83401812	FRONT PANEL ASSY	TMA	S10	240	15003254	WIRE (YELLOW)	129	S7					
167	83401811	FRONT PANEL ASSY	TMA	S3	240	15003254	WIRE (YELLOW)	108 130	S8					
167	83401811	FRONT PANEL ASSY	TMA	S10	241	15003309	WIRE	106-109	S7					
168	77594704	DPT TRACK SENSE ASSY	TMA	S3	241	15003309	WIRE	128	S7					
168	77594704	DPT TRACK SENSE ASSY	TMA	S9	241	15003309	WIRE	109	S8					
169	77594705	DPT TRACK SENSE ASSY	TMA	S3	242	75738480	CAPACITOR	108	S8					
169	77594705	DPT TRACK SENSE ASSY	TMA	S9	243	75738405	CAPACITOR	109	S7					
170	83401808	FRONT PANEL ASSY	TMA	S3	244	75772500	CAPACITOR BOOT	128 109	S7					
					244	75772500	CAPACITOR BOOT	108	S8					

TOP-DOWN ASSEMBLY/COMPONENT PARTS LIST (CONT.)

ITEM	IDENT NO	DESCRIPTION	WHERE USED	SHEET	ITEM	IDENT NO	DESCRIPTION	WHERE USED	SHEET
245	77835131	SOLENOID BRKT	295	S10	310	75790803	SHAFT	171	S5
246	77834212	SOLENOID	295	S10	311	83426400	EXPANDER-CONE	171	S5
247	93530103	FIN ROLL	295	S10	312	77830481	CONE-DISK LOAD	171	S5
248	75806507	WASHER	295	S10	313	83402200	SPRING CONE	171	S5
249	77834323	SPRING	295	S10	314	75812129	DOOR (BLK)	166	S10
250	93592482	SCR HEX HD	101 115	S5	315	83409701	SPRING-GARTER	171	S5
251	77832458	OPTICAL SWITCH	125 127	S9	316	94047069	WASHER	171	S5
252	75293954	CONNECTOR	125	S9	317	94047070	WASHER	171	S5
252	75293954	CONNECTOR	168	S9	318	77839901	CARRIAGE ASSY	138	S6
253	94245602	CONTACT	125 127	S9	319	77833505	MOTOR PULLEY ASSY	113	S7
253	94245602	CONTACT	168	S9	320	75812011	SUPPORT DIE CAST MACHINED	368	S5
254	10125759	SCREW FLAT HD	168	S9	321	75292807	BEARING-CYLINDRICAL	368	S5
255	10127131	SCREW	152	S4	322	75813201	BUSHING, PUSH ROD MOLDED	368	S5
256	10125805	LOCK WASHER	152	S4	323	75813202	BUSHING, PUSH ROD MOLDED	368	S5
257	83460400	HOLDER PAD	326	S6	324	75893025	MOUNT	169	S9
258	93592164	SCR HX SELF TAP	125	S9	325	77603100	ARM-HEAD LOAD	281 318	S6
258	93592164	SCR HX SELF TAP	127	S9	326	77830482	HOLDER-PAD ASSY	281 318	S6
259	77835305	LABEL	168	S9	327	10127321	SCR PAN HD	295	S10
260	75791600	MOUNT	147	S9	328	77643443	LEVER KNOB	166	S10
261	75724402	SWITCH	147	S9	329	77830998	PIN CARRIAGE	281 318	S6
262	75293956	CONNECTOR	127	S9	330	77830999	SPRING TORSION	281 318	S6
263	83402301	LATCH-DOOR INJEC MOL	132-135	S10	331	94047068	WASHER, SPECIAL	281 318	S6
263	83402301	LATCH-DOOR INJEC MOL	166 170	S10	332	75889161	LATCH DOOR	161	S10
263	83402301	LATCH-DOOR INJEC MOL	150	S11	333	10127310	SCREW SLOTTED	281 318	S6
264	77594403	MOUNT	168	S9	334	10125001	SCREW HEX HD	137 138	S6
265	77834318	LEVER-DOOR	161	S10	335	94047000	WASHER	137 138	S6
266	92096099	PIN-GROOVED	131-136	S10	336	93592160	SCREW, SELF TAP	101 115	S4
266	92096099	PIN-GROOVED	161 170	S10	337	93464000	WIRE BLACK	114 128	S7
266	92096099	PIN-GROOVED	166-167	S10	338	83435511	CONTACT PIN	102-128	S7
266	92096099	PIN-GROOVED	150	S11	338	83435511	CONTACT PIN	108	S8
267	75292700	KNOB-LEVER	132-136	S10	335	10126401	STAR LOCK WASHER	101 115	S4
267	75292700	KNOB-LEVER	170	S10	340	75731302	ELECTRICAL SYMBOL	101 115	S4
267	75292700	KNOB-LEVER	150	S11	342	77594800	DECAL	152	S4
268	83401200	SPRING-LATCH	131-136	S10	344	75724543	CONNECTOR PANEL MTG	124	S7
268	83401200	SPRING-LATCH	161 170	S10	345	75724586	CONNECTOR PANEL MTG	124	S7
268	83401200	SPRING-LATCH	166-167	S10	346	83426204	CARRIAGE HEAD ASSY	281	S6
268	83401200	SPRING-LATCH	150	S11	347	93464555	WIRE 16 GRN	124	S7
269	83413406	SCR SET SOC HS 6-32	131-136	S10	348	75724587	CONTACT PIN	129	S7
269	83413406	SCR SET SOC HD 6-32	166-167	S10	348	75724587	CONTACT PIN	112 114	S8
269	83413406	SCR SET SOC HD 6-32	161 170	S10	349	75724587	CONTACT PIN	130	S8
269	83413406	SCR SET SOC HD 6-32	150	S11	349	51797214	LUG TERM RING CRIMP	112 114	S7
270	10125606	WASHER	108 130	S8	349	51797214	LUG TERM RING CRIMP	129	S7
271	75292701	KNOB-LEVER	161	S10	349	51797214	LUG TERM RING CRIMP	130	S8
272	83413404	SCREW-SELF LOCKING	131-136	S10	350	75724569	CONNECTOR PANEL MTG	129	S7
272	83413404	SCREW-SELF LOCKING	166-167	S10	350	75724569	CONNECTOR PANEL MTG	112 114	S7
272	83413404	SCREW-SELF LOCKING	150	S10	350	75724569	CONNECTOR PANEL MTG	130	S8
272	83413404	SCREW-SELF LOCKING	161 170	S11	351	75724585	CONNECTION PANEL	129	S7
273	83426521	PANEL FRONT, BLACK HW	133	S10	351	75724585	CONNECTION PANEL	130	S8
274	75812121	DOOR, FINISHED, PA-BLK	133	S10	353	75724401	ACTUATOR SWITCH	101 115	S5
275	83426622	PANEL FRONT, WHITE HW	134	S10	354	09000004	SCREW BIND HEAD	147	S9
276	75812122	DOOR, FINISHED, PA-WHT	134	S10	355	75885407	OPTICAL SWITCH	168	S9
277	83426623	PANEL FRONT, FIN BLUE	135	S10	357	77832410	PANEL FRONT BLK-BURR	131	S10
278	75812123	DOOR, FINISHED, PA-BLU	135	S10	358	83426205	CARRIAGE HEAD ASSY	318	S6
279	83461110	FRONT PANEL FINISHED	136	S10	359	77830977	LATCH DOOR	131 167	S10
280	75747801	STEPPER MOTOR ASM	137 138	S6	360	75886086	BASE-MECHANISM, DIE	101	S4
281	77839902	CARRIAGE ASM	137	S6	361	83403601	SPINDLE	101 115	S4
283	75881371	SHIM	131 167	S10	362	75747000	SPACER BEARING	101 115	S4
284	77594000	SPRING-CARRIAGE	137 138	S6	363	75745200	PULLEY-SPINDLE	101 115	S4
285	75896352	DOOR LEVER SPRING	161	S10	364	75886087	BASE-MECHANISM, DIE	115	S4
286	10126209	SCR-SOC HP CAP	281 318	S6	365	83461800	CLAMP, STEPPER MOTOR	101 115	S4
287	75812124	DOOR FINISHED BLACK	132 136	S10	366	75292400	GUIDE-CARRIAGE	101 115	S4
287	75812124	DOOR FINISHED BLACK	131 161	S10	367	83461801	STEPPER MOTOR CLAMP	115	S4
287	75812124	DOOR FINISHED BLACK	150	S11	368	75812021	SUPPORT-ASSEMBLED	101	S5
288	75813000	RETAINER-BEARING	137 138	S6	369	83402803	ARM-DISK LOAD	101	S5
289	77613699	BEARING FLANGED	137 138	S6	370	75273000	PIN DISK LOAD ARM	101 115	S5
290	94217207	BRG BALL-EXT INNER R	137 138	S6	371	75881370	LEVER DOOR	131 167	S10
291	93529901	WASHER-SPRING WAVL	137 138	S6	372	77832119	BUTTON LATCH	131 167	S10
292	83403202	BAR TORSION DOOR	131-136	S10	373	77835304	LABEL	324 358	S6
292	83403202	BAR TORSION DOOR	166-167	S10	374	94277400	TIE STRAP	101	S4
292	83403202	BAR TORSION DOOR	161 170	S10	374	94277400	TIE STRAP	125 127	S9
292	83403202	BAR TORSION DOOR	150	S11	375	83427303	NUT CARRIAGE	137 138	S6
293	83461111	FRONT PANEL	161	S10	376	75812022	SUPPORT-ASSEMBLED	115	S5
293	83461111	FRONT PANEL	150	S10	377	93592486	SCREW	101 115	S4
294	77832456	LUBRICANT	137 138	S6	378	95862300	ANCHOR CABLE TIE	161	S10
295	77835133	DOOR LK ASSY	161	S10	378	95862300	ANCHOR CABLE TIE	150	S11
296	91976207	SCREW	161	S10	379	77835132	SPACER BKT	295	S10
297	77833702	HARNASS DR LK	161	S10	380	10125102	SCR NUT HEX	168	S9
298	75810703	RETAINING RING	161	S10	381	10125100	WASH FMT TOOTH LK	168	S9
298	75810703	RETAINING RING	150	S11	388	10125603	WASHER	101 115	S4
299	75810701	DIODE LIGHT	161	S10	388	10125603	WASHER	101 115	S4
299	75810701	DIODE LIGHT	150	S11	389	83402804	ARM-DISK LOAD	115	S5
300	83461200	LATCH DOOR	135	S10	390	77833527	PULLEY MOTOR ASSY	114	S7
301	77833975	ADAPTER	152	S4	391	77833525	PULLEY MOTOR ASSY	112	S7
302	83401500	BUSHING-DOOR INJECT	131-136	S10					
302	83401500	BUSHING-DOOR INJECT	166-167	S10					
302	83401500	BUSHING-DOOR INJECT	161 170	S10					
302	83401500	BUSHING-DOOR INJECT	150	S11					
303	75746000	LEVER-DOOR	132-136	S10					
303	75746000	LEVER-DOOR	170 166	S10					
303	75746000	LEVER-DOOR	150	S11					
304	75746800	BRACKET LATCH	131-136	S10					
304	75746800	BRACKET LATCH	161 170	S10					
304	75746800	BRACKET LATCH	166-167	S10					
304	75746800	BRACKET LATCH	150	S11					
305	10125804	LK WASHER	108 130	S8					
306	83460701	PAD HEAD LOAD	326	S6					
307	77830550	SOLID STATE RELAY	156	S9					
308	10127334	SCREW	156	S9					
309	10125105	NUT	156	S9					

CROSS REFERENCE LIST

ITEM IDENT NO	SHEET	ITEM IDENT NO	SHEET	ITEM IDENT NO	SHEET	ITEM IDENT NO	SHEET
154 09000004	S9	162 75746701	S3	127 77830690	S3	269 83413406	S10
197 09000005	S5	149 75746702	S3	127 77830690	S9	269 83413406	S10
198 09000402	S5	304 75746800	S11	179 77830732	S5	269 83413406	S10
199 09000403	S4	304 75746800	S10	301 77830975	S4	269 83413406	S11
200 09000504	S5	304 75746800	S10	359 77830977	S10	346 83426204	S6
334 10125001	S6	304 75746800	S10	157 77830995	S3	358 83426205	S6
386 10125102	S9	362 75747000	S4	329 77830998	S6	311 83426800	S5
309 10125105	S9	173 75747202	S5	330 77830999	S6	273 83426821	S10
388 10125603	S4	141 75747301	S3	372 77832119	S10	275 83426822	S10
388 10125603	S5	280 75747801	S6	168 77832145	S4	277 83426823	S10
187 10125605	S4	244 75772500	S7	357 778322410	S10	195 83426824	S10
270 10125606	S8	244 75772500	S8	216 778322411	S10	211 83426826	S10
254 10125759	S9	183 75774732	S3	294 77832456	S6	233 83426828	S10
178 10125801	S4	139 75774736	S4	251 77832458	S9	375 83427303	S6
186 10125803	S5	231 75790000	S7	152 77832661	S3	125 83427801	S3
186 10125803	S4	231 75790000	S7	152 77832661	S4	125 83427801	S9
186 10125803	S9	231 75790000	S7	227 77833501	S7	210 83427900	S4
305 10125864	S2	231 75790000	S6	226 77833502	S7	234 83434502	S7
756 10125905	S4	310 75790803	S5	220 77833503	S7	234 83434502	S7
387 10146100	S9	137 75791510	S3	221 77833504	S7	234 83434502	S8
286 10126209	S6	137 75791510	S6	232 77833505	S7	234 83434502	S7
209 10146214	S4	138 75791511	S3	319 77833505	S7	236 83435501	S7
201 10126219	S5	138 75791511	S6	228 77833506	S7	236 83435501	S8
202 10126222	S4	260 75791600	S9	224 77833507	S7	338 83435511	S7
339 10126401	S4	248 75806507	S10	222 77833519	S7	338 83435511	S8
185 10127123	S8	299 75810701	S10	223 77833520	S7	101 83458201	S3
254 10127131	S4	299 75810701	S11	391 77833525	S7	101 83458201	S4
333 10127330	S6	298 75810703	S11	390 77833527	S7	101 83458201	S5
327 10127331	S10	298 75810703	S10	297 77833702	S10	148 83460101	S3
308 10127334	S9	320 75812011	S5	246 77834212	S10	257 83460400	S6
240 15003254	S8	368 75812021	S5	112 77834213	S3	306 83460701	S6
240 15003254	S7	376 75812022	S5	112 77834213	S7	279 83461110	S10
240 15003254	S7	274 75812121	S10	114 77834214	S3	293 83461111	S10
241 15003309	S7	276 75812122	S10	114 77834214	S7	293 83461111	S11
241 15003309	S7	278 75812123	S10	265 77834318	S10	300 83461200	S10
241 15003309	S8	278 75812123	S10	249 77834323	S10	365 83461800	S4
196 16402506	S4	287 75812124	S10	175 77834326	S5	367 83461801	S4
155 17901508	S3	287 75812124	S10	174 77834331	S5	296 91976207	S10
214 24548311	S9	215 75812126	S10	160 77834336	S3	193 92033037	S5
213 24548313	S9	217 75812128	S10	161 77834543	S10	194 92033038	S5
349 51797214	S7	314 75812129	S10	161 77834543	S3	194 92033038	S5
349 51797214	S8	288 75813000	S6	245 77835131	S10	266 92096099	S11
349 51797214	S7	322 75813201	S5	379 77835132	S10	266 92096099	S10
238 51797233	S7	323 75813202	S5	295 77835133	S10	266 92096099	S10
238 51797233	S8	371 75881379	S10	189 77835200	S5	266 92096099	S10
239 62121108	S7	283 75881377	S10	373 77835304	S6	153 92602001	S4
239 62121108	S8	225 75881760	S7	259 77835305	S9	208 92602003	S4
145 75272300	S3	225 75881760	S7	164 77836055	S3	307 93464000	S7
370 75273000	S5	230 75881762	S8	318 77839901	S6	347 93464555	S7
172 75273200	S5	229 75881768	S8	281 77839962	S6	291 93529001	S6
124 75291902	S3	199 75881775	S3	268 83401200	S11	192 93529005	S4
124 75291902	S7	199 75881775	S7	268 83401200	S10	247 93530103	S10
102 75291920	S3	126 75881779	S3	268 83401200	S10	237 93541002	S9
102 75291920	S7	126 75881779	S7	302 83401500	S10	205 93592086	S5
111 75291921	S3	129 75881780	S3	302 83401500	S10	205 93592086	S4
103 75291923	S3	129 75881780	S7	302 83401500	S10	335 93592162	S10
103 75291923	S7	218 75882450	S4	302 83401500	S10	203 93592162	S10
113 75291924	S3	177 75882711	S6	132 83401801	S3	203 93592162	S10
113 75291924	S7	176 75885163	S5	132 83401801	S10	203 93592162	S11
107 75291925	S3	355 75885107	S9	133 83401802	S10	258 93592164	S9
107 75291925	S7	360 75886085	S4	133 83401802	S3	258 93592164	S9
104 75291926	S3	364 75886178	S3	134 83401803	S3	155 93592240	S3
104 75291926	S7	108 75886178	S7	134 83401803	S10	250 93592242	S5
105 75291927	S3	130 75886181	S3	135 83401804	S3	377 93592486	S4
105 75291927	S7	130 75886181	S7	135 83401804	S10	219 93592488	S4
106 75291928	S3	130 75886181	S3	136 83401805	S3	206 93820248	S5
106 75291928	S7	332 75889161	S10	136 83401805	S10	335 94047000	S6
182 75292617	S5	181 75891000	S5	131 83401806	S3	321 94047068	S6
366 75292800	S4	115 75891480	S5	131 83401806	S10	316 94047069	S5
267 75292700	S10	115 75891480	S3	170 83401808	S3	317 94047070	S5
267 75292700	S10	115 75891480	S4	170 83401808	S10	290 94217207	S6
271 75292701	S10	328 75893025	S9	151 83401809	S3	190 94217702	S7
321 75292807	S5	285 75896352	S10	151 83401809	S10	253 94245602	S9
180 75293203	S4	204 75898043	S10	167 83401811	S10	253 94245602	S9
252 75293954	S9	150 75898080	S3	167 83401811	S3	374 94277400	S9
252 75293954	S9	150 75898080	S11	166 83401812	S3	374 94277400	S4
262 75293956	S9	235 75898086	S11	166 83401812	S10	122 94277416	S3
353 75724401	S5	284 77594000	S6	171 83402101	S5	122 94277416	S11
261 75724402	S9	254 77594403	S9	313 83402200	S5	122 94277416	S10
344 75724543	S7	168 77594704	S9	263 83402301	S11	212 94279109	S5
350 75724569	S7	159 77594705	S3	263 83402301	S10	378 95862300	S10
350 75724569	S8	159 77594705	S9	263 83402301	S10	378 95862300	S11
350 75724569	S7	342 77594800	S4	369 83402803	S5		
351 75724565	S7	147 77594901	S3	369 83402804	S5		
351 75724565	S8	147 77594901	S9	292 83403202	S10		
345 75724586	S7	325 77603100	S6	292 83403202	S10		
346 75724587	S8	184 77613696	S5	292 83403202	S11		
346 75724587	S7	131 77613697	S4	143 83403503	S3		
348 75724567	S8	289 77613699	S6	142 83403504	S3		
340 75731302	S4	328 77643443	S10	361 83403601	S4		
243 75738403	S7	312 77830461	S5	144 83403700	S3		
242 75738403	S8	326 77830482	S6	315 83409701	S5		
363 75745200	S4	145 77830535	S3	207 83411202	S5		
303 75746000	S10	307 77830641	S9	272 83413404	S11		
303 75746000	S10	155 77830641	S3	272 83413404	S10		
303 75746000	S11	140 77830685	S3	272 83413404	S10		

FIGURE 5-2. SCHEMATIC (SHEET 1 OF 2)

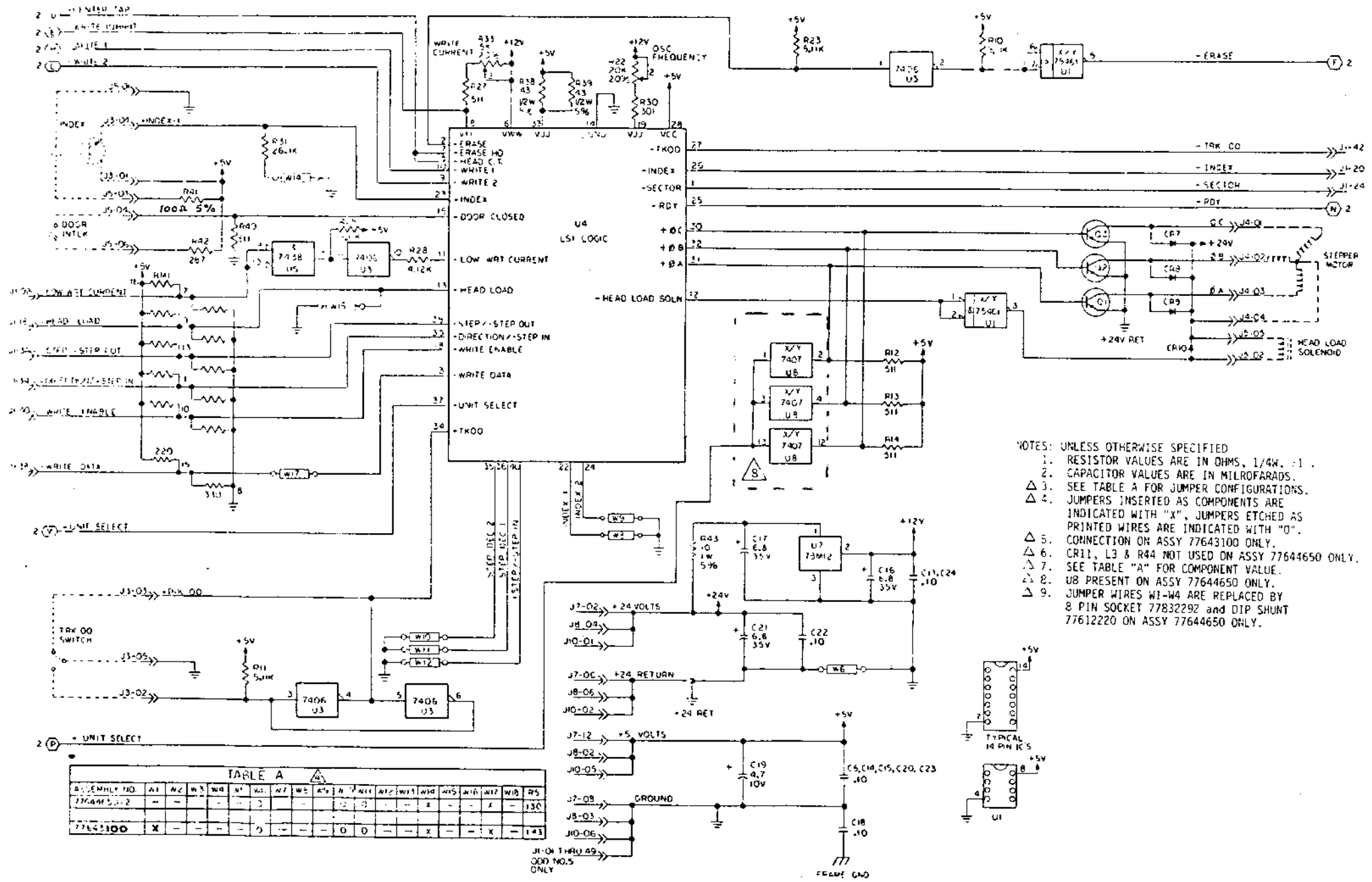
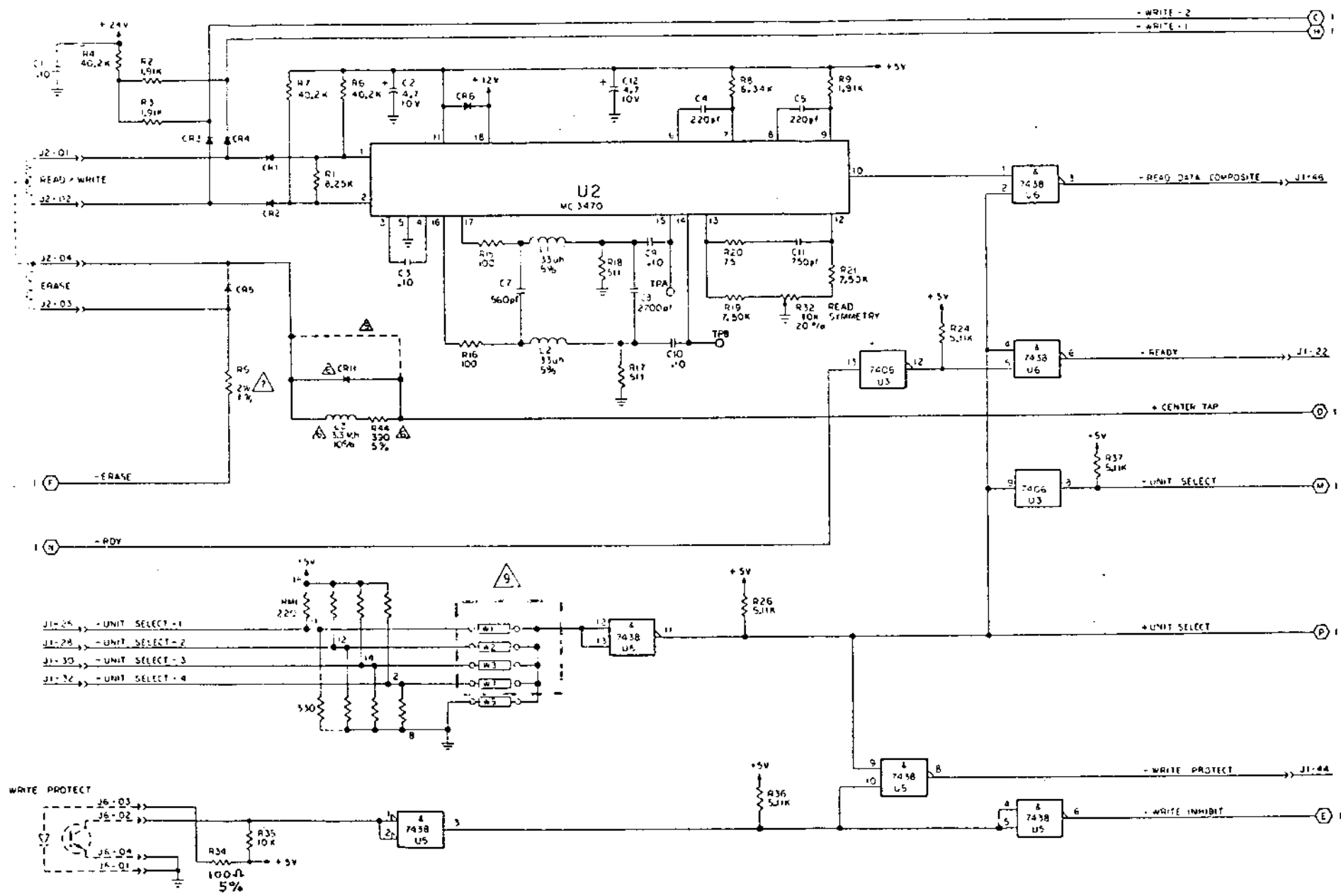

FIGURE 5-2. SCHEMATIC (SHEET 2 OF 2)



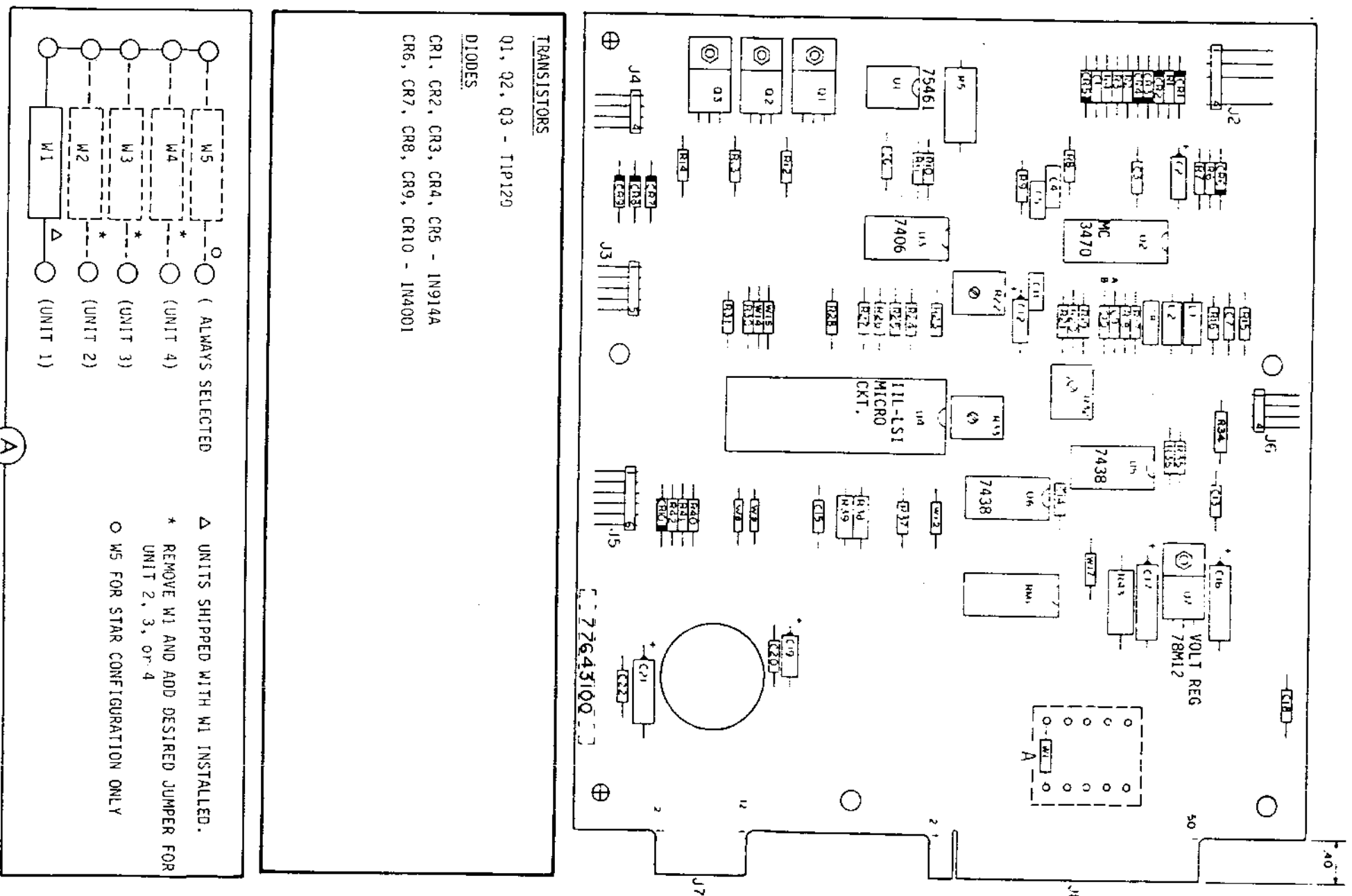
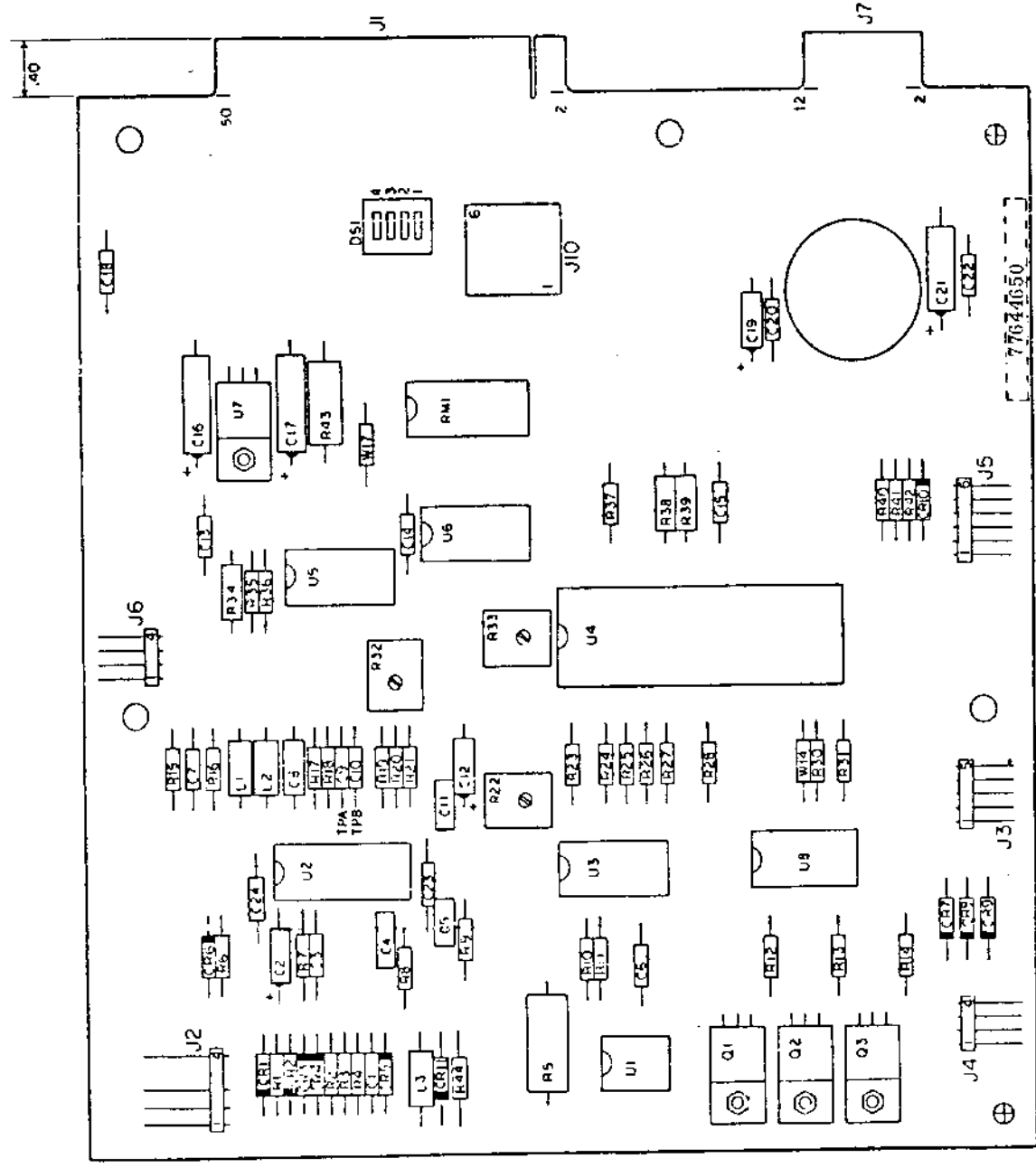

FIGURE 5-3A. ASSEMBLY AND PARTS LIST
 (PWA 77643100)



- TRANSDUCERS
 01, 02, 03 - T1P120
- DIODES
 CR1, CR2, CR3 } 1N914A
 CR4, CR5
 CR6, CR7, CR8
 CR9, CR10, CR11 } 1N4001

FIGURE 5-3B. ASSEMBLY AND PARTS LIST
 (PWA 77644650)

(DS-1-DIP SHUNT - AMP 435704-4 - shipped with all positions shorted.
 To select address punch out all shunts except one corresponding to the
 desired address.)

STAPLE

STAPLE

FOLD

FOLD

BUSINESS REPLY MAIL
 No Postage Stamp Necessary If Mailed in the United States

POSTAGE WILL BE PAID BY

MAGNETIC PERIPHERALS INC.
 P.O. BOX 12313
 OKLAHOMA CITY, OKLAHOMA 73157

Attention Technical Publications, OKM250

FIRST CLASS
 Permit Number 1332
 OKLAHOMA CITY,
 OKLAHOMA

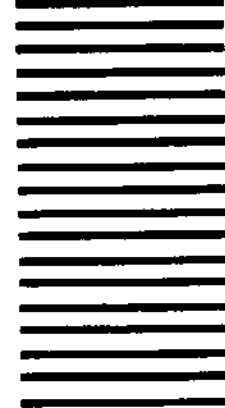

CUT ALONG LINE

FOLD

FOLD