

EK-LW100-OP-001

# Letterwriter 100 Operator Guide

**digital**



# Letterwriter 100 Operator Guide

First Edition, June 1982

Copyright © 1982 by Digital Equipment Corporation

All Rights Reserved

The reproduction of this material, in part or whole, is strictly prohibited. For copy information, contact the Educational Services Department, Digital Equipment Corporation, Maynard, Massachusetts 01754.

The information in this document is subject to change without notice. Digital Equipment Corporation assumes no responsibility for any errors that may appear in this document.

Printed in U.S.A.

• **Class A Computing Devices:**

**Notice:** This equipment generates, uses, and may emit radio frequency energy. The equipment has been type tested and found to comply with the limits for a Class A computing device pursuant to Subpart J of Part 15 of FCC Rules, which are designed to provide reasonable protection against such radio frequency interference when operated in a commercial environment. Operation of this equipment in a residential area may cause interference in which case the user at his own expense may be required to take measures to correct the interference.

The following are trademarks of Digital Equipment Corporation, Maynard, Massachusetts.

DEC	DECnet	OMNIBUS
DECUS	DECsystem-10	OS/8
DIGITAL	DECSYSTEM-20	PDT
Digital Logo	DECwriter	RSTS
PDP	DIBOL	RSX
UNIBUS	EduSystem	VMS
VAX	IAS	VT
Module Mailer	MASSBUS	Letterwriter

## CONTENTS

### INTRODUCTION

### CHAPTER 1 CONTROLS AND INDICATORS

General .....	1-1
Printer Controls .....	1-1
Voltage Selector Switch .....	1-1
Power ON/OFF Switch .....	1-1
Paper Adjust Knobs .....	1-3
Paper Release Knobs .....	1-3
Printhead Release Lever .....	1-3
Printhead Adjustment Lever .....	1-3
Ribbon Adjust Knob .....	1-3
Tractor Release Levers .....	1-3
Tractor Adjust Levers .....	1-3
Paper Out Override Switch .....	1-3
Font Selection Switch .....	1-10
Keyboard Controls .....	1-10
Standard Keys .....	1-10
CAPS LOCK .....	1-10
SHIFT .....	1-10
Auto-Repeat .....	1-13
Function Keys .....	1-13
ESCAPE .....	1-13
TAB .....	1-13
CONTROL .....	1-13
AUTO/MANUAL .....	1-13
LETTER/DRAFT .....	1-13
VIEW/FAULT RESET .....	1-16
LINE/LOCAL .....	1-17
HERE IS .....	1-17
LOCAL FORM FEED .....	1-17
LOCAL LINE FEED .....	1-17
BACKSPACE .....	1-17
BREAK .....	1-17
DELETE .....	1-17
RETURN .....	1-17
LINE FEED .....	1-17
PF1 PF2 PF3 PF4 .....	1-17
ENTER .....	1-18

SET-UP Keys .....	1-18
SET-UP .....	1-18
SET TAB .....	1-18
CLEAR TAB .....	1-18
CLEAR ALL .....	1-18
TOP (Top of Form) .....	1-18
TOP/LEFT MAR (Top/Left Margin) .....	1-18
BOT/RT MAR (Bottom/Right Margin) .....	1-18
MAR CLEAR (Margin Clear) .....	1-18
STATUS .....	1-20
STORE/RECALL .....	1-20
Visual Indicators .....	1-20
POWER/FAULT .....	1-20
SET-UP .....	1-20
DSR .....	1-20
LINE .....	1-20
CTS (Clear to Send) .....	1-20
Font .....	1-20
ROM Cartridge .....	1-23
Column .....	1-23
Audible Indicators .....	1-23

## CHAPTER 2 RIBBON AND PAPER INSTALLATION

General .....	2-1
Ribbon Cartridge Installation .....	2-1
Loading Paper and Preprinted Forms .....	2-4
Friction Feed Paper .....	2-4
Tractor Feed Paper .....	2-4
Loading Friction Feed Paper .....	2-4
Single Sheet .....	2-4
Roll Paper .....	2-6
Loading Tractor Feed Paper/Forms .....	2-8
Printhead Adjustment .....	2-13

## CHAPTER 3 OPERATOR-SELECTABLE FEATURES

General .....	3-1
SET-UP .....	3-1
Operator Preference Features .....	3-2
Last Character View .....	3-2
Keyclick .....	3-2
Form Features .....	3-3
Recommended Sequence .....	3-3
Pitch Select Mode .....	3-4
Horizontal Pitch .....	3-4
Horizontal Margins and Tabs .....	3-6
Clearing Horizontal Margins .....	3-6
Setting Left Horizontal Margin .....	3-8
Clearing a Single Horizontal Tab .....	3-8
Clearing All Horizontal Tabs .....	3-8
Setting Horizontal Tabs .....	3-9
Setting Right Horizontal Margin .....	3-9

Vertical Pitch .....	3-9
Form Length .....	3-11
Top of Form .....	3-13
Vertical Margins and Tabs .....	3-13
Clearing Vertical Margins .....	3-15
Setting Top Vertical Margin .....	3-15
Clearing a Single Vertical Tab .....	3-16
Clearing All Vertical Tabs .....	3-16
Setting Vertical Tabs .....	3-16
Setting Bottom Vertical Margin .....	3-17
Communication Compatibility Features .....	3-17
Parity and Data Bits .....	3-17
Receiver Error Processing .....	3-18
Baud Rate .....	3-18
Modem Control .....	3-19
Paper Fault .....	3-20
Coded Disconnect .....	3-20
Local Echo .....	3-21
Auto-XON/XOFF .....	3-21
Answerback .....	3-23
Entering/Deleting the Answerback Message .....	3-23
Auto-Answerback .....	3-25
End of Line Control .....	3-25
Printer New Line .....	3-26
Printer Character Set .....	3-27
BREAK Key .....	3-28
Alternate Keypad .....	3-29
Auto-Linefeed .....	3-31
Keyboard Layout .....	3-31
Self-Test .....	3-32
Feature Memories .....	3-32
Operating Memory .....	3-32
Status Message .....	3-34
User Permanent Memory .....	3-34
Store .....	3-34
Recall .....	3-36
Default Memory .....	3-36

## CHAPTER 4 MAINTENANCE AND TROUBLESHOOTING

General .....	4-1
Maintenance .....	4-1
Troubleshooting Checklist .....	4-3
Self-Tests .....	4-5
Power-Up Self-Test .....	4-5
Printer Self-Tests .....	4-5
Character Pattern .....	4-9
Single Character .....	4-9
Vertical Bar .....	4-9
Nonprinting .....	4-11
Loopback .....	4-11
Installation/Warranty .....	4-12

DIGITAL Services .....	4-12
On-Site Service .....	4-12
Off-Site Service .....	4-13
Spare Parts .....	4-13
Training .....	4-13

## CHAPTER 5 ACCESSORIES AND SUPPLIES

General .....	5-1
Supplies .....	5-1
Accessories .....	5-3
Loopback Connectors .....	5-7
Documentation .....	5-7
Spares Kits .....	5-8
Ordering Information .....	5-8

## APPENDIX A LETTERWRITER 100 MODEL VARIATIONS

### FIGURES

1-1	Voltage Selector Switch .....	1-2
1-2	Power ON/OFF Switch .....	1-2
1-3	Paper Adjust Knobs .....	1-4
1-4	Paper Release Lever .....	1-4
1-5	Printhead Release Lever .....	1-5
1-6	Printhead Adjustment Lever .....	1-6
1-7	Ribbon Adjust Knob .....	1-7
1-8	Tractor Release Levers .....	1-8
1-9	Tractor Adjust Levers .....	1-9
1-10	Paper Out Override Lever .....	1-9
1-11	Font Selection Switch .....	1-11
1-12	Letterwriter 100 Keyboard .....	1-12
1-13	Standard Keys .....	1-12
1-14	Function keys .....	1-14
1-15	Printing Examples .....	1-15
1-16	SET-UP Keys .....	1-19
1-17	Keyboard Indicators .....	1-21
1-18	Font Indicators .....	1-22
1-19	ROM Cartridge Indicator .....	1-24
1-20	Column Indicator .....	1-25
2-1	Carriage Assembly .....	2-1
2-2	Ribbon Cartridge .....	2-3
2-3	Loading Single Sheet Paper .....	2-5
2-4	Single Sheet Paper Path .....	2-5
2-5	Loading Roll Paper .....	2-7
2-6	Roll Paper Path .....	2-7
2-7	Loading Tractor Feed Paper .....	2-9
2-8	Tractor Feed Paper Path (Without Stand) .....	2-10
2-9	Tractor Feed Paper Path (With Stand) .....	2-12
2-10	Printhead Adjustment .....	2-14
3-1	Horizontal Pitch Examples .....	3-5
3-2	Horizontal Margins and Tabs .....	3-7
3-3	Vertical Pitch Examples .....	3-10
3-4	Selecting Vertical Pitch .....	3-12



3-5	Vertical Form Settings .....	3-14
3-6	Local Echo Feature .....	3-22
3-7	Answerback Message Protect Jumper .....	3-24
3-8	Feature Memories .....	3-33
3-9	Sample Status Message .....	3-35
4-1	Access Cover Removal .....	4-2
4-2	Platen Removal .....	4-2
4-3	AC Line Fuse Location .....	4-3
4-4	Self-Test Examples .....	4-8
4-5	Loopback Connectors .....	4-10

#### TABLES

1-1	Audible Indicators .....	1-26
3-1	Maximum Right Margins .....	3-5
3-2	Printer New Line Selections .....	3-26
3-3	Auxiliary Keypad Characters and Escape Sequences .....	3-30
3-4	Feature Default Values .....	3-37
4-1	Troubleshooting Checklist .....	4-3
4-2	Power-Up Self-Test Indications .....	4-6



## INTRODUCTION

### **The Letterwriter 100**

This section introduces you to the Letterwriter 100 and its new features. The Letterwriter 100 is a microprocessor-controlled, versatile, desk-top printing terminal.

### **Variable Density**

The Letterwriter 100 uses a dot matrix printing technique and can print in four main applications.

- Correspondence quality (high density, low speed)\*
- Memorandum quality (medium density, medium speed)\*
- Draft quality (high speed, low density)
- Graphics (computer defines printed dots)

Any characters printed by the terminal can be printed in draft, memo or letter quality.

### **Fonts**

The terminal can print characters in different font styles. Changing a font changes the shape of the character, but not the character itself. DIGITAL currently provides the following fonts. Additional fonts will be available in the future.

- Courier 10
- Courier 12
- Orator 10
- Gothic 12
- Symbols

The terminal can contain up to five accessible fonts anytime. You do not have to change a print wheel or element to use a different font.

Three of the fonts can be installed inside the terminal only, therefore, they are safe from changes. Two can be installed either inside or outside the terminal using the multiple font option (LAL0X-FL) and read-only memory (ROM) cartridges. Fonts installed on the outside of the terminal are easy to change.

---

\* High or medium density depends on the character ROM selected.

### **Character Sets**

The 7-bit code can access 94 printable characters anytime. So the terminal can use more characters, the characters are grouped in sets of 94 (character sets). Each character set has an associated name and designator character. Up to 80 character sets can be used anytime. Usually the number of character sets does not exceed ten. Changing a character set changes the character accessed by a given code or key. A separate character set is needed for each font.

### **Forcing Fonts or Density**

The computer can select the print density and font. However, you may want to use the same file to print in a different density or font (e.g. print orator for slide presentation and courier for printed handouts). Therefore, it is possible to override or force the computer selected font or density. Force the density using the AUTO/MANUAL key. Force the font using the font select switch. If you force the font or density, the computer cannot change the forced font or density. The computer commands to change font or density are received and processed, but do not take effect until the terminal is set back to the computer select state.

### **Horizontal Pitch**

Horizontal pitch is the width of a character as well as the spacing between characters. The Letterwriter 100 has eight user-selectable horizontal pitches.

Each font has a designed or standard pitch (usually 10 or 12 characters per inch). A character is designed to be printed at a given pitch and is optimized to give the best result at that pitch.

Varying the horizontal pitch can be done by modifying a given character dot pattern or by using different character dot patterns for various pitches.

Characters printed in draft mode can be printed in all eight pitches. In memorandum or letter mode, different character dot patterns must be used to achieve the required quality, unless the requested width is exactly double of the standard pitch.

You can force the draft mode to print only in the pitches that would be available in memorandum or letter mode by using the pitch mode setting.

### **Character ROMs**

Character ROMs contain a certain character set at a certain font at a certain horizontal pitch. A character ROM may be used alone or as a complement to another ROM. If the character ROM is used alone, it is a primary ROM. If it is used to complement another ROM, it is a ROM overlay. Overlay ROMs must match the primary ROM font and pitch, but add different character sets to the primary ROM.

There are two types of character ROMs, plug-in ROMs and ROM cartridges. Plug-in ROMs must be plugged into one of the five ROM sockets inside the terminal. ROM cartridges are used with the multiple font option (LA10X-FL).

You can use the five ROM slots to configure the terminal for the most flexibility for your application. You can use five primary ROMs providing five different fonts or various pitches. Or, you can use three primaries and two overlay ROMs to expand the character sets.

You may choose to install the ROMs inside the terminal so the configuration is stable, or you may use the multiple font option to provide even more flexibility.

Note: The multiple font option replaces two of the internal ROMs. It makes it easier to change the configuration, but does not expand the number of possible ROMs. Remember, you may decide to change the configuration anytime by changing your choice of ROM options.

#### Vertical Form Features

The Letterwriter 100 handles vertical form features differently from previous DIGITAL terminals. Previous terminals base vertical form features on lines. The Letterwriter 100 vertical form features are based on inches. Changing vertical pitch does not change the form length, top and bottom margins, or top of form. The terminal always prints a distance from the top margin which is a multiple of the vertical pitch.

The Letterwriter 100 also has a no form mode that is used with roll feed paper. No form mode allows the terminal to print continuously because roll paper does not require a perforation skip.

#### BOOK INTRODUCTION

A complete list of the Letterwriter 100 models is given in Appendix A. The Letterwriter 100 User Documentation Package covers all Letterwriter 100 model terminals and addresses three general audiences.

- The hardware installer requiring specific installation and checkout information
- The operator requiring general operating information
- The applications programmer requiring interface and control function descriptions

Four documents make up Letterwriter 100 documentation.

- Operator and Programmer Reference Card
- Installation Guide
- Operator Guide
- Programmer Reference Manual

This guide contains required information for operating Letterwriter 100 terminals. The operator should use this guide as a reference when operating the terminal. The application software determines terminal operation with the computer, therefore, you should use your application software document also.

The Operator Guide contains the following chapters.

Chapter 1, Controls and Indicators, provides a general introduction to Letterwriter 100 operation and shows all the controls and indicators of the terminal.

Chapter 2, Ribbon and Paper Installation, describes the procedures to change ribbon cartridges, load paper or preprinted forms, and adjust the printhead.

Chapter 3, Operator Selectable Features, describes in detail the procedure to enter and exit SET-UP and each SET-UP feature.

Chapter 4, Maintenance and Troubleshooting, describes the general cleaning and care recommendations. The chapter also provides a list of checks the operator should make before requesting service. The warranty information and services available from DIGITAL are described in this chapter.

Chapter 5, Accessories and Supplies, describes the accessories and supplies offered for the Letterwriter 100. Included in this chapter is a short description of each accessory and supply, part number, and ordering information.

Appendix A lists and describes all of the Letterwriter 100 models available from DIGITAL.

#### **WARNINGS, CAUTIONS, AND NOTES**

In this book, warnings, cautions, and notes are used for specific purposes. Warnings highlight information used to prevent personal injury. Cautions highlight information used to prevent damage to the terminal. Notes highlight general information.

CHAPTER 1  
CONTROLS AND INDICATORS

**GENERAL**

This chapter describes each Letterwriter 100 control and indicator. Detailed operating information can depend on the computer software. The Letterwriter 100 has many different controls and indicators used by the operator to control and monitor terminal operation. The controls and indicators chapter is organized as follows.

- Printer controls
- Keyboard controls
- Visual indicators
- Audible indicators

**PRINTER CONTROLS**

The following paragraphs describe the function of the printer controls.

**Voltage Selector Switch**

This switch (Figure 1-1) changes the terminal to match the available ac input voltage range. Refer to the Installation Guide to change the voltage range selected.

CAUTION: Failure to set the voltage selector switch to the correct voltage range can damage the power supply.

Always use a small blade screwdriver or ball point pen to change the voltage selection. Never use a lead pencil because broken lead can cause a short circuit on the printed circuit board.

**Power ON/OFF Switch**

This switch turns terminal power on or off (Figure 1-2). The ON position is labeled "ON 1" and the OFF position is labeled "OFF 0". One of the keyboard indicators goes on to indicate that power is on.

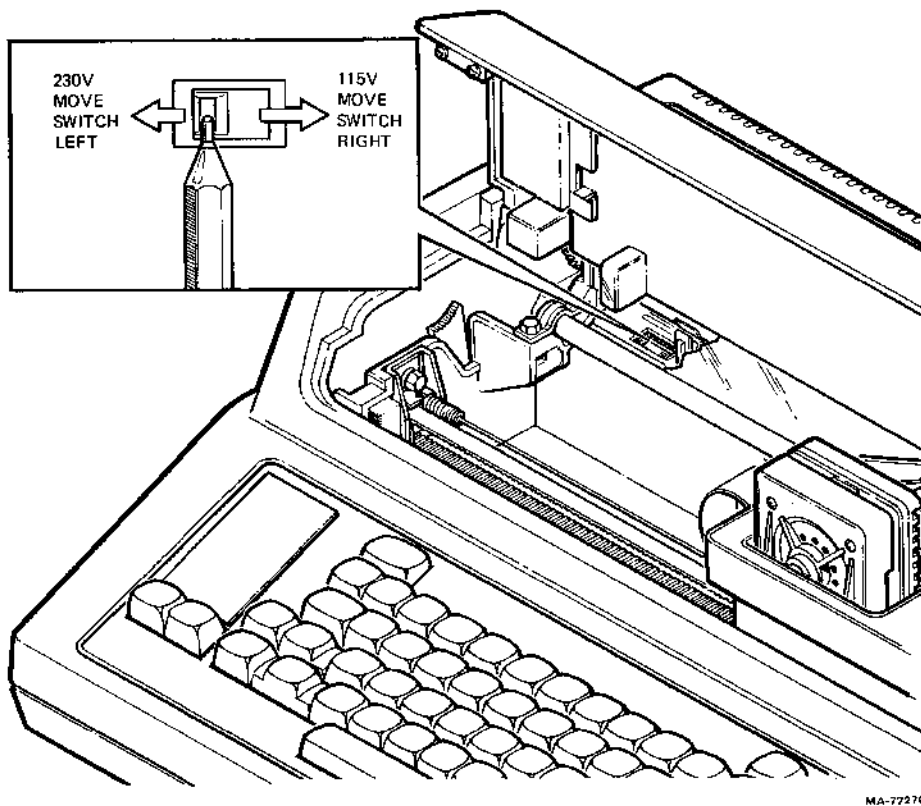

Figure 1-1 Voltage Selector Switch

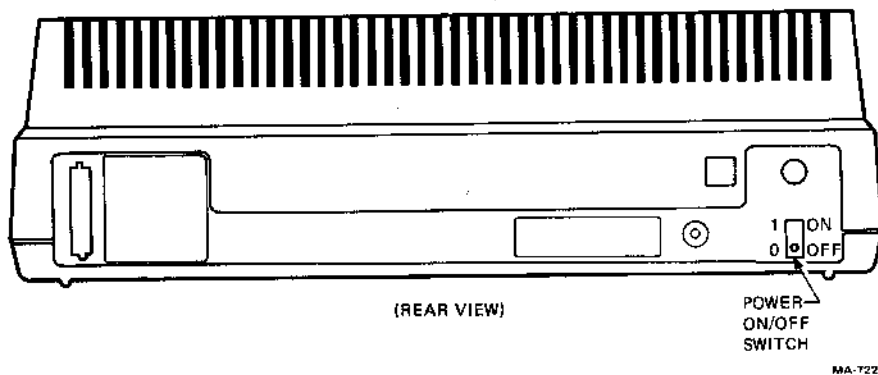

Figure 1-2 Power ON/OFF Switch



### **Paper Adjust Knobs**

These knobs advance paper 1/12 of an inch at a time (Figure 1-3). Press in the right paper adjust knob and turn it in either direction to roll the paper. This knob allows precise vertical paper positioning.

NOTE: Moving the paper adjust knob changes the top of form reference.

### **Paper Release Lever**

This lever (Figure 1-4) is used to reposition or remove paper from the terminal.

### **Printhead Release Lever**

This lever (Figure 1-5) is used to remove or install the printhead. When moved toward the back of the terminal, the printhead can be removed. When moved toward the front of the terminal, the printhead is locked in place.

### **Printhead Adjustment Lever**

This lever (Figure 1-6) controls the space between the printhead and the platen. Use the printhead adjustment lever to adjust the printhead for clear printing on single or multipart forms. Refer to Chapter 2 for the printhead adjustment.

### **Ribbon Adjust Knob**

This knob is used to tighten the ribbon when installing a new ribbon cartridge (Figure 1-7). Refer to Chapter 2 for the ribbon cartridge installation procedure.

### **Tractor Release Levers (Part of the LAX34-AL Tractor Option)**

These levers are used to install or remove the LAX34-AL Tractor Option (Figure 1-8). Refer to the Installation Guide for the tractor option installation procedure.

### **Tractor Adjust Levers (Part of the LAX34-AL Tractor Option)**

The tractors can be moved horizontally to hold different size paper. The tractor adjust levers (Figure 1-9) are used to clamp the tractors in place. Pull the lever toward the front of the terminal to move the tractor. Push the lever toward the back of the terminal to lock the tractor in place. Refer to Chapter 2 for the correct tractor adjustment procedure.

### **Paper Out Override Switch**

This switch is used to disable paper out detection. This feature is useful when using single-sheet paper or forms (Figure 1-10).

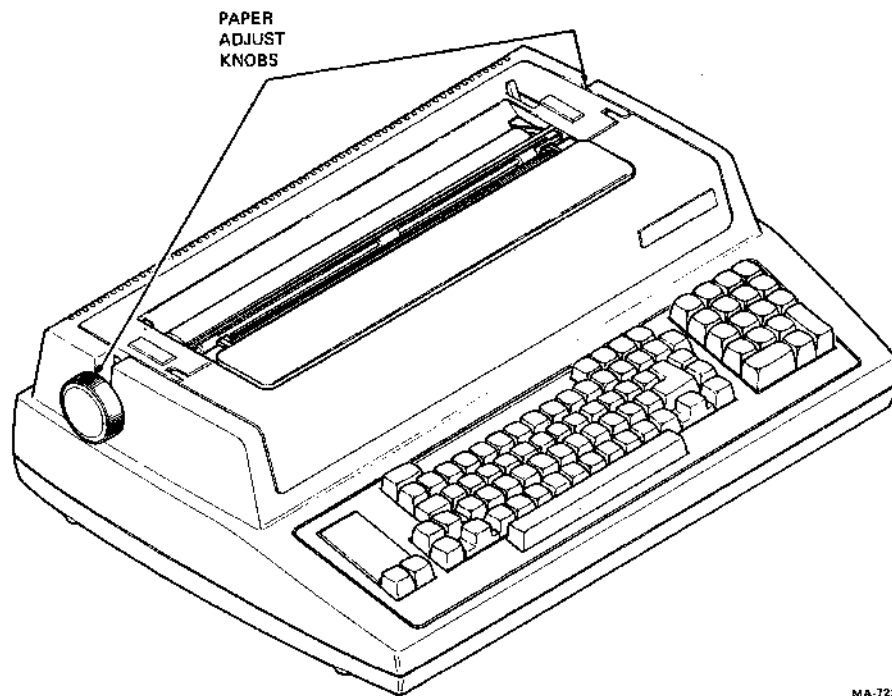

Figure 1-3 Paper Adjust Knobs

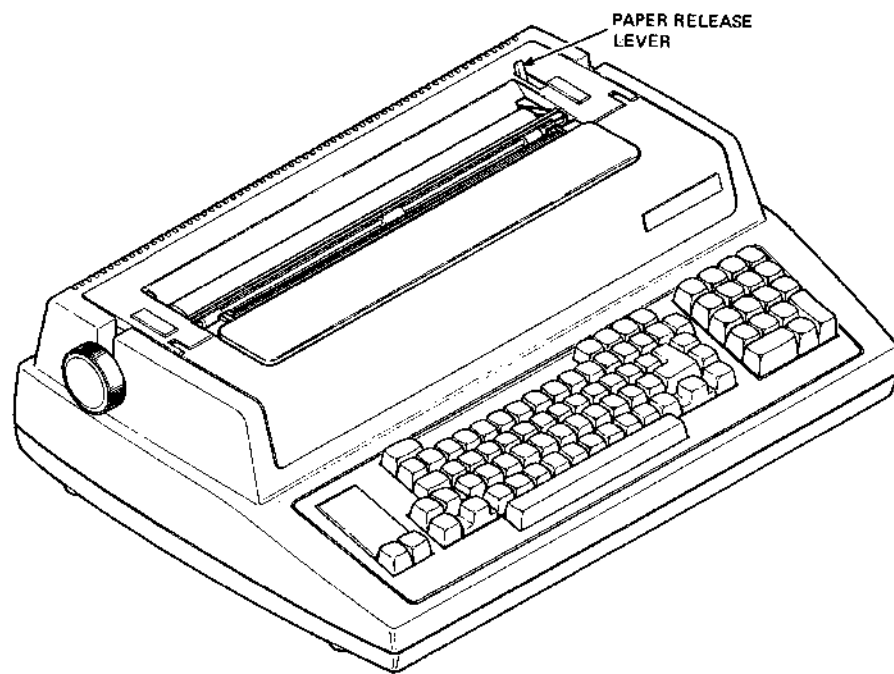
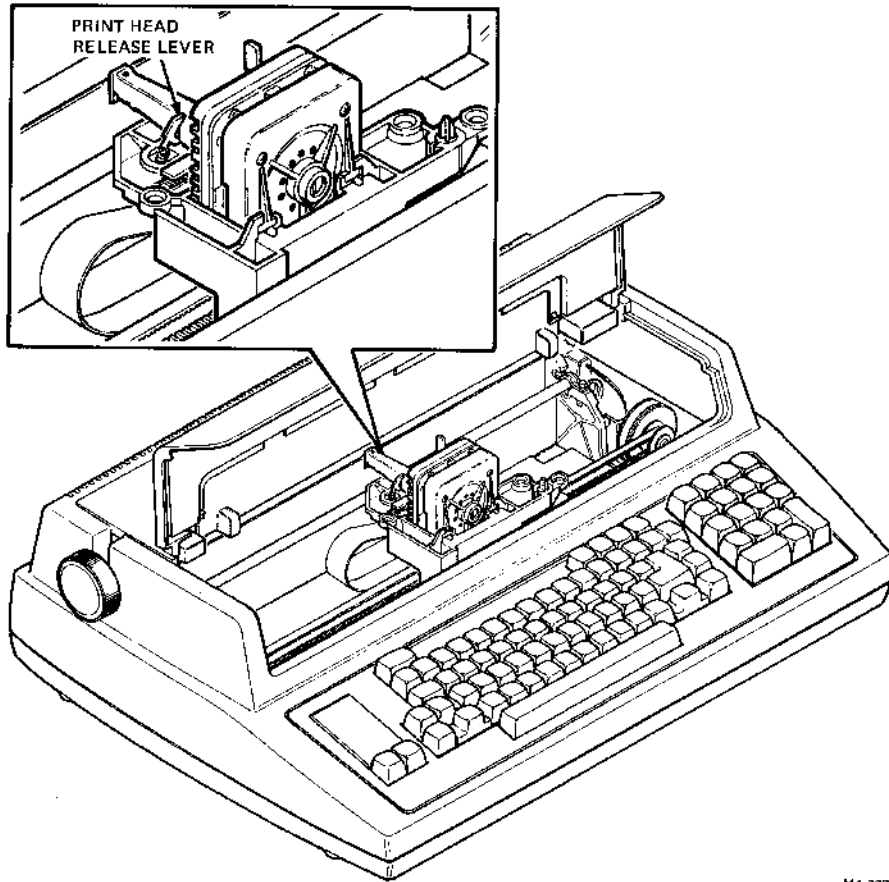
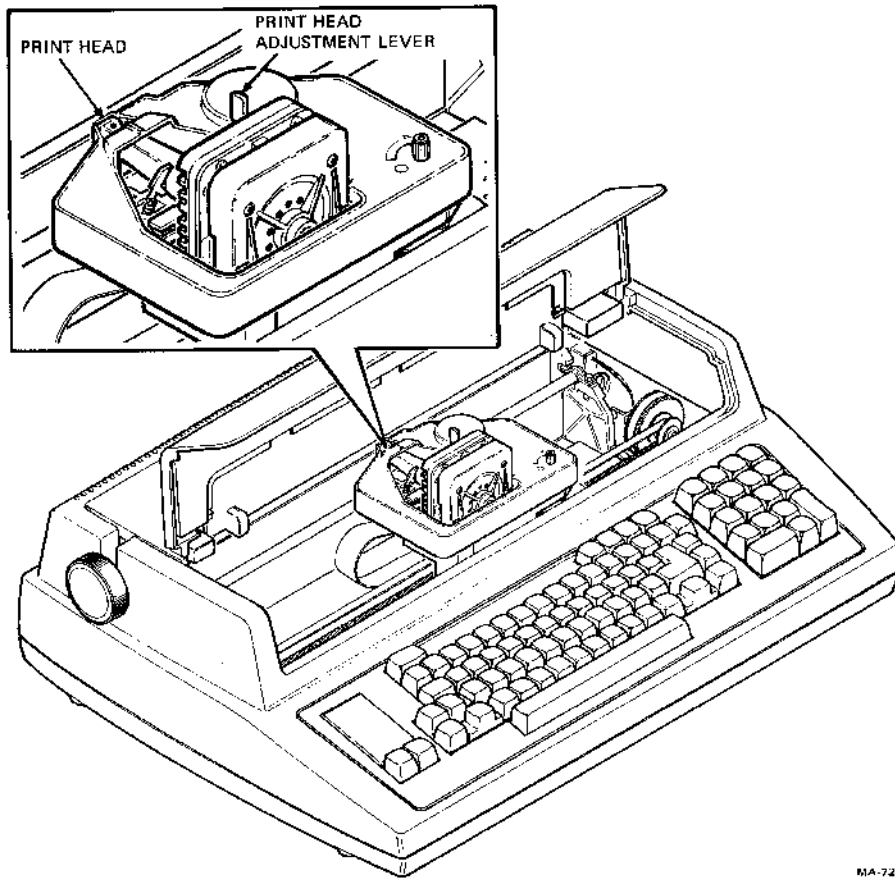

Figure 1-4 Paper Release Lever



MA 7231D

Figure 1-5 Printhead Release Lever



MA-7231C

Figure 1-6 Printhead Adjustment Lever

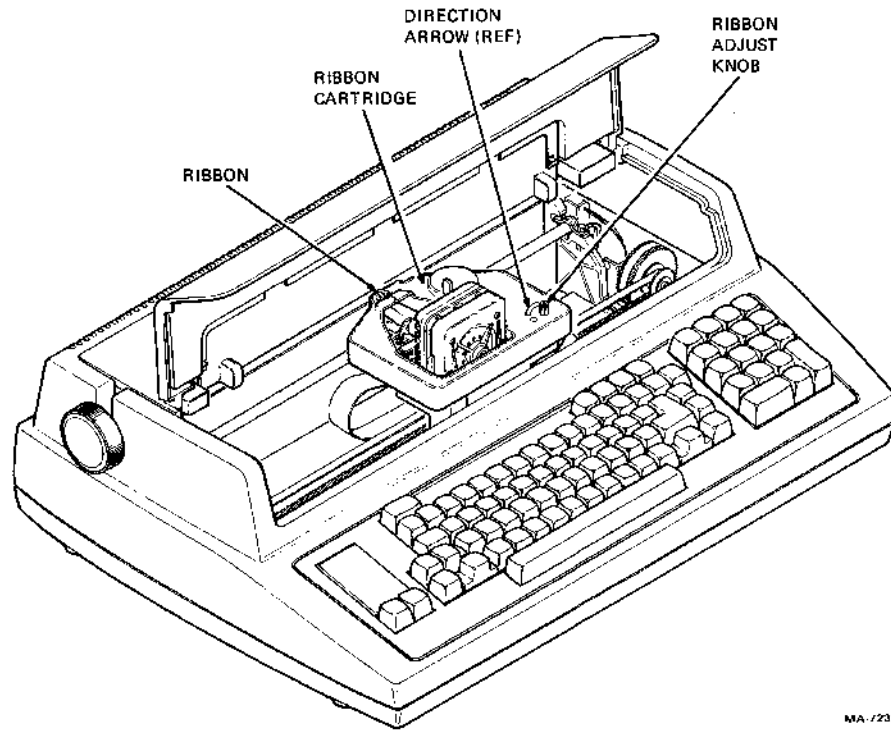

MA /232B

Figure 1-7 Ribbon Adjust Knob

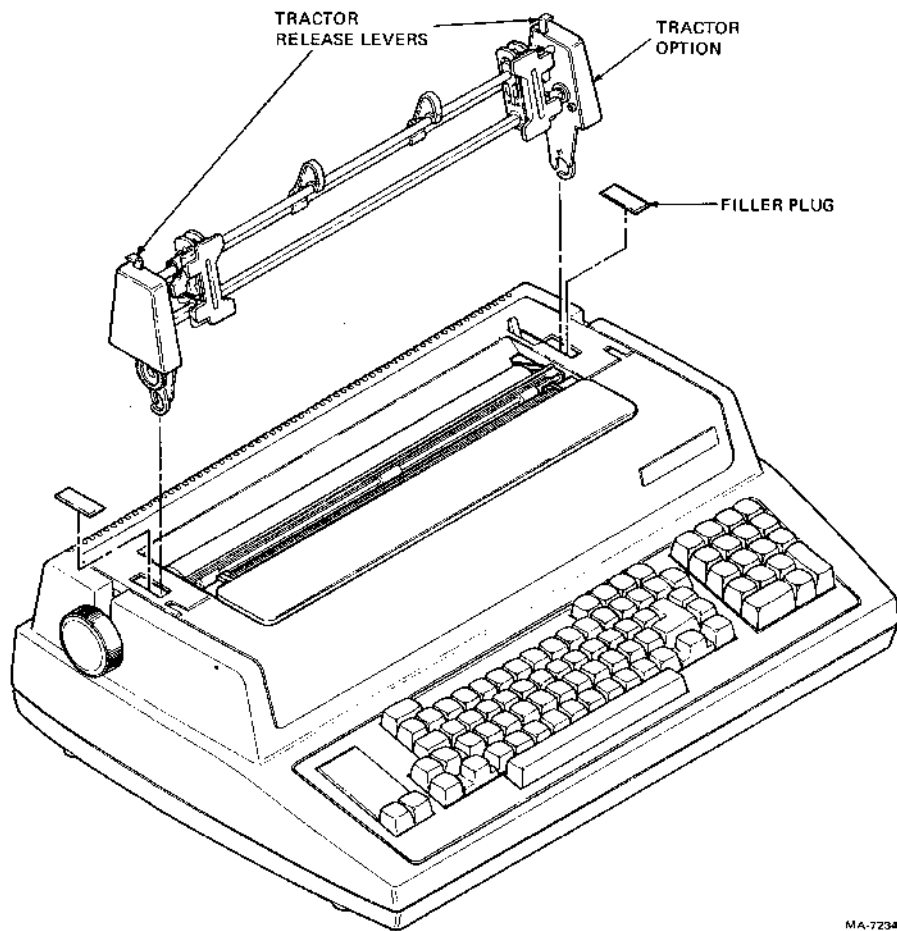

MA-7234B

Figure 1-8 Tractor Release Levers

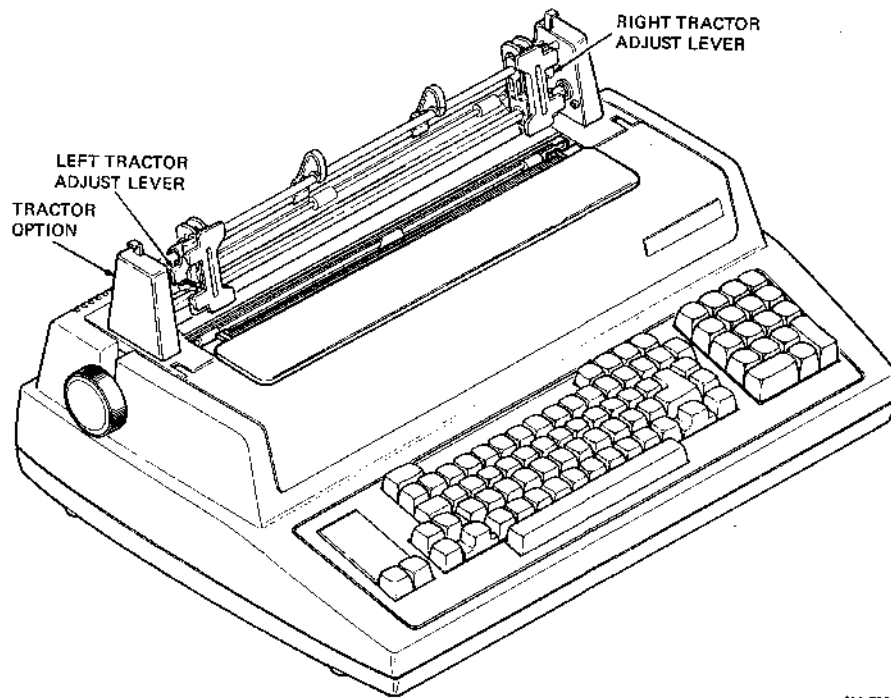

MA-7233B

Figure 1-9 Tractor Adjust Levers

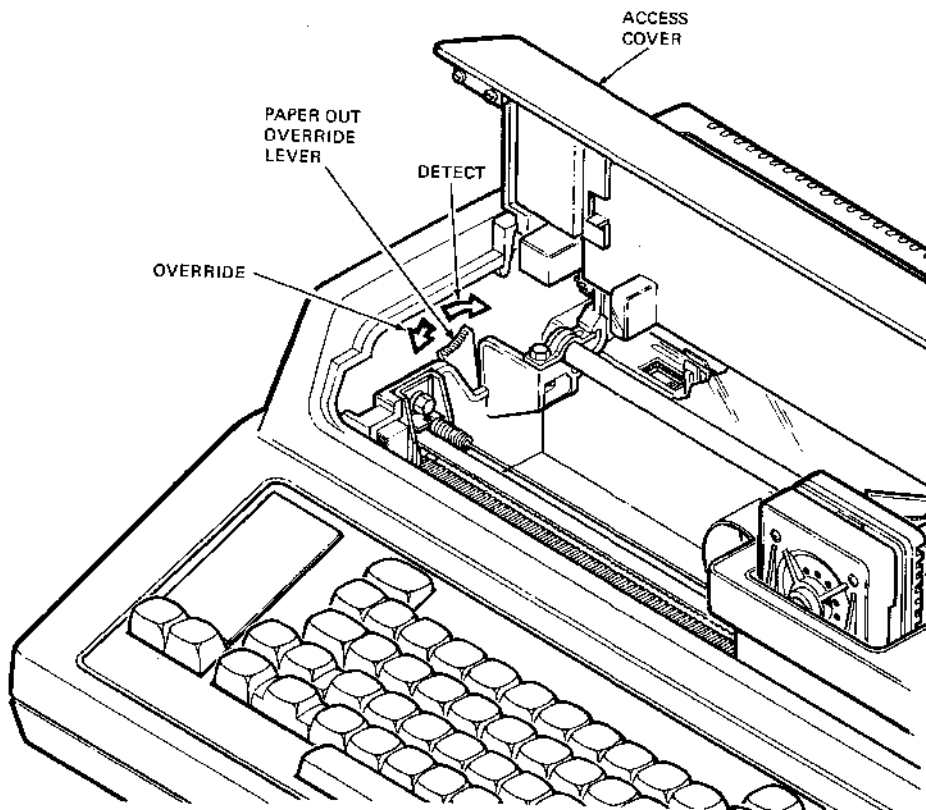

MA-7235B

Figure 1-10 Paper Out Override Lever

### Font Selection Switch (Part of LAX24-FL Multiple Font Option)

This switch (Figure 1-11) is used by the operator to force a font or allow the computer to select the fonts. Each time the switch is pressed, the terminal advances to the next state, skipping fonts that are not installed. If the currently forced font is removed, the terminal advances to the next valid state. The terminal steps through the following states each time the switch is pressed.

- Computer select (power-up state)
- Font 1 forced
- Font 2 forced (upper cartridge)
- Font 3 forced
- Font 4 forced (lower cartridge)\*
- Font 5 forced\*

NOTE: To force a font means that everything is printed using that font despite all computer commands. The computer commands are processed but do not take effect until the terminal is set to computer select mode.

### KEYBOARD CONTROLS

The Letterwriter 100 keyboard has a main keyboard and an optional auxiliary keypad (Figure 1-12). The main keyboard is arranged and operates similarly to a standard office typewriter. The auxiliary keypad is arranged to allow rapid entry of numeric data. The keyboard controls are described in three groups.

- Standard keys
- Function keys
- SET-UP keys

#### Standard Keys

The shaded keys in Figure 1-13 are standard keys. These keys are used to send characters to the computer. The **SHIFT** keys and the **CAPS LOCK** key are also described here. These keys do not transmit characters to the computer. However, they do modify the characters sent by the main keyboard.

NOTE: The alternate keypad SET-UP feature changes the function of the auxiliary keypad keys. Refer to Chapter 3 for more detail.

#### CAPS LOCK

This key is a two-position locking key. In the down position, alphabetic keys generate uppercase characters regardless of the position of the **SHIFT** keys. In the up position, the alphabetic keys generate lowercase characters. The numeric, special symbol, function and auxiliary keypad keys are not affected by this key.

#### SHIFT

Either of these keys cause the standard keys on the main keyboard to generate uppercase characters. The **SHIFT** keys do not affect the function and auxiliary keypad keys.

\* if not used for overlays.



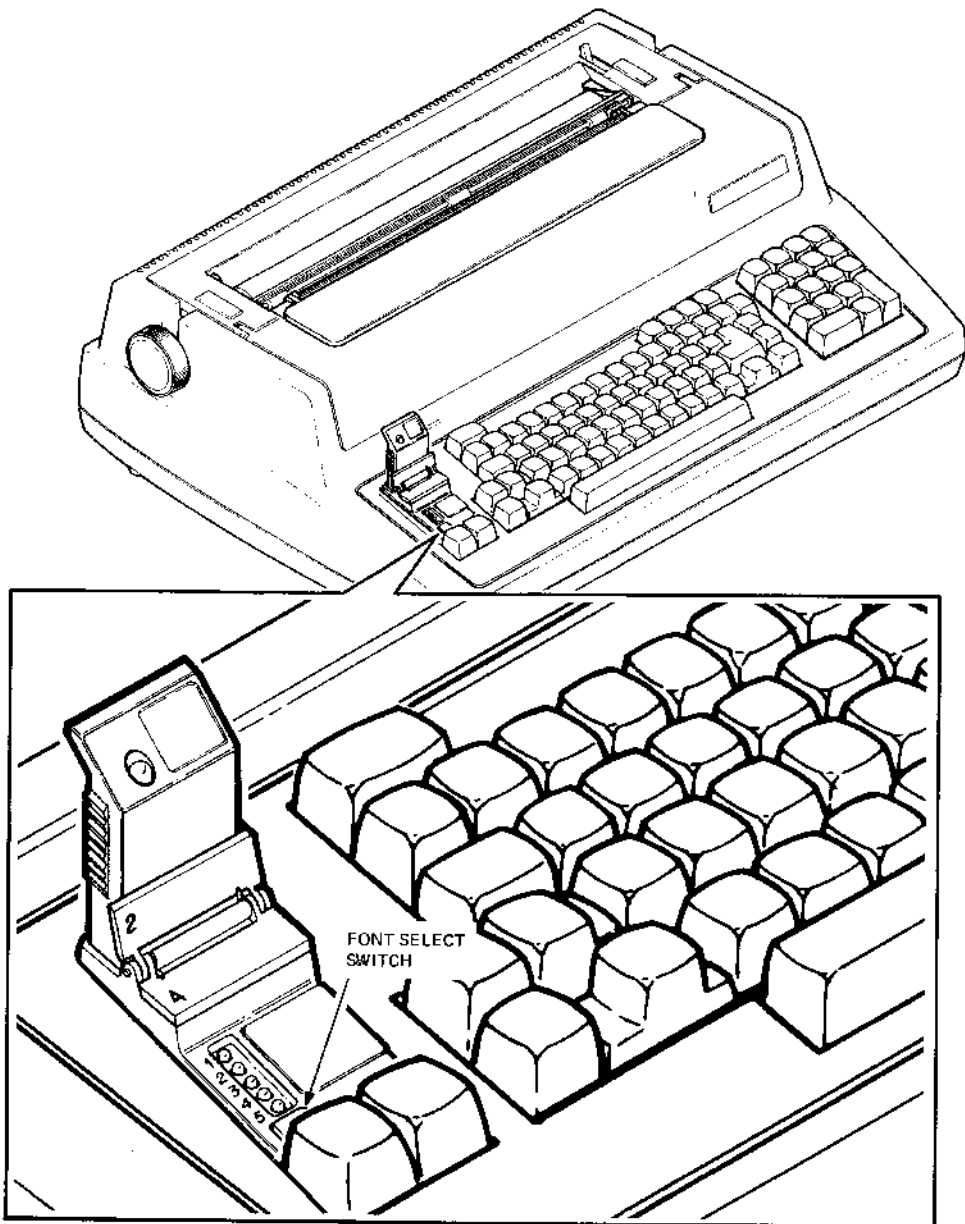

MA-7237G

Figure 1-11 Font Selection Switch

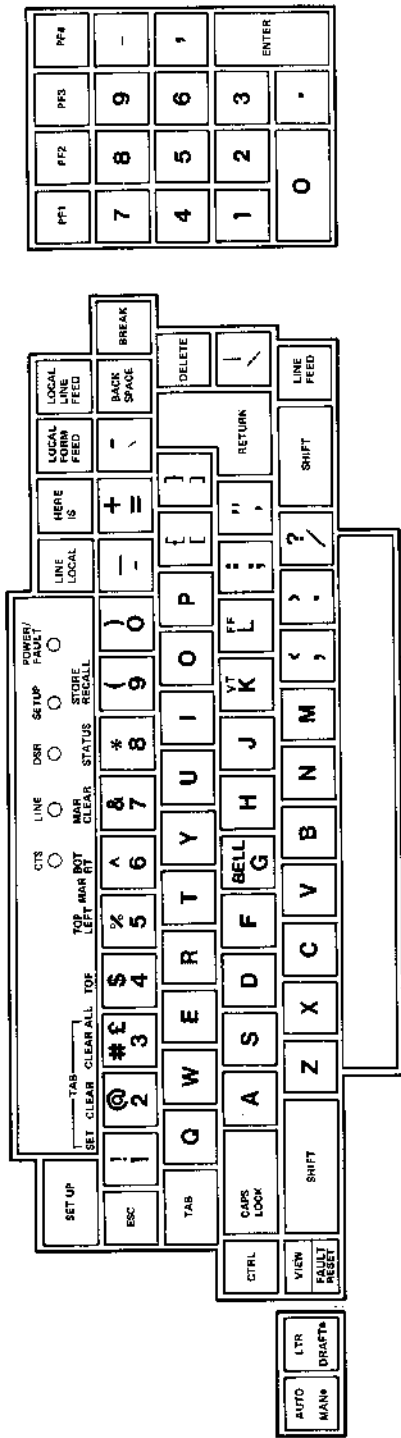

MAJ200

Figure 1-12 Letterwriter 100 Keyboard

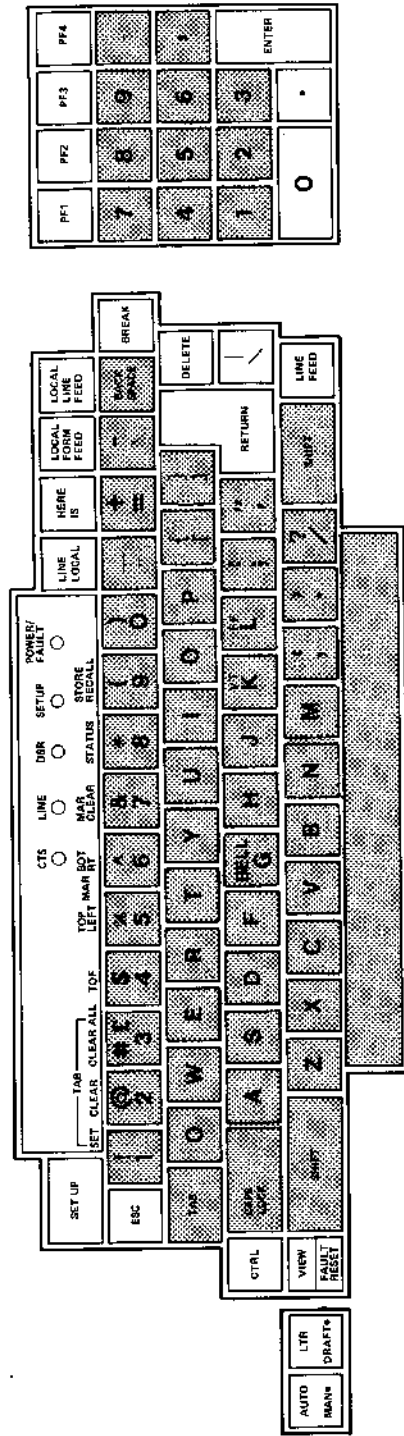

MAJ200

Figure 1-13 Standard Keys

**Auto-Repeat** -- If the **BACKSPACE** key, **DELETE** key, or any of the standard keys outlined in Figure 1-13 are pressed for more than 0.6 seconds, then the code for that key is transmitted over and over at the rate of 15 characters per second. If an auto-repeat is in progress, all other keys pressed are ignored until the repeating key is released. If more than one key is pressed before an auto repeat begins, only the last key pressed will repeat automatically.

### **Function Keys**

Figure 1-14 shows the function keys on the main keyboard. The following paragraphs describe each function key.

#### **ESCAPE**

This key causes the terminal to generate the escape control character.

#### **TAB**

This key causes the terminal to generate the horizontal tab control character.

#### **CONTROL**

When a standard key on the main keyboard is pressed while the **CTRL** key is pressed, the terminal generates a control character.

#### **AUTO/MANUAL**

In the **AUTO** position (up), print quality (draft/letter mode) is controlled by the computer. The **LETTER/DRAFT** key is inactive.

In the **MANUAL** position (down), the print quality (draft/letter mode) is controlled by the **LETTER/DRAFT** key. Quality (draft/letter mode) control escape sequences from the computer are processed, but only take action when auto mode is selected.

#### **LETTER/DRAFT**

In the **LETTER** position (up), the terminal prints letter mode (medium or high density depending on character ROM) characters. See Figure 1-15 for examples.

In the **DRAFT** position (down), the terminal prints draft mode (low density) characters. See Figure 1-15 for an example.

NOTE: The **LETTER/DRAFT** key is active only when the **AUTO/MANUAL** key is the the **MANUAL** (down) position.



!"#\$%&'()\*+,-./0123456789:;<=>?@ABCDEFGHIJKLMN OPQRSTUVWXYZ[\]^\_`abcd  
!"#\$%&'()\*+,-./0123456789:;<=>?@ABCDEFGHIJKLMN OPQRSTUVWXYZ[\]^\_`abcde  
!"#\$%&'()\*+,-./0123456789:;<=>?@ABCDEFGHIJKLMN OPQRSTUVWXYZ[\]^\_`abcdef  
!"#\$%&'()\*+,-./0123456789:;<=>?@ABCDEFGHIJKLMN OPQRSTUVWXYZ[\]^\_`abcdefg

DRAFT

!"#\$%&'()\*+,-./0123456789:;<=>?@ABCDEFGHIJKLMN OPQRSTUVWXYZ[\]^\_`abcd  
!"#\$%&'()\*+,-./0123456789:;<=>?@ABCDEFGHIJKLMN OPQRSTUVWXYZ[\]^\_`abcde  
!"#\$%&'()\*+,-./0123456789:;<=>?@ABCDEFGHIJKLMN OPQRSTUVWXYZ[\]^\_`abcdef  
!"#\$%&'()\*+,-./0123456789:;<=>?@ABCDEFGHIJKLMN OPQRSTUVWXYZ[\]^\_`abcdefg

MEMO

!"#\$%&'()\*+,-./0123456789:;<=>?@ABCDEFGHIJKLMN OPQRSTUVWXYZ[\]^\_`abc  
!"#\$%&'()\*+,-./0123456789:;<=>?@ABCDEFGHIJKLMN OPQRSTUVWXYZ[\]^\_`abcd  
!"#\$%&'()\*+,-./0123456789:;<=>?@ABCDEFGHIJKLMN OPQRSTUVWXYZ[\]^\_`abcde  
!"#\$%&'()\*+,-./0123456789:;<=>?@ABCDEFGHIJKLMN OPQRSTUVWXYZ[\]^\_`abcdef

LETTER

MA-8300

Figure 1-15 Printing Examples

#### **VIEW/FAULT RESET**

When manual last character view is selected, the VIEW key manually causes the printhead to move 1 cm (0.4 in) to the right of the last character printed. This allows the user to see the last character printed. When the VIEW key is pressed along with the CTRL key, last character viewing is switched from manual to automatic. Last character viewing is then performed automatically without operator control. When the VIEW key is pressed again with the CTRL key, the terminal switches back to manual last character view. Refer to Chapter 3 for more detail.

The FAULT RESET key resets the fault indication of the terminal to permit continued operation after any fault (e.g., printhead jam, cover open) has occurred and has been corrected.

#### **LINE/LOCAL**

This key switches the terminal between on-line and local. While on-line, the terminal can transmit and receive characters. While local, the terminal cannot transmit or receive characters and characters typed at the keyboard are printed by the terminal. The LINE indicator lights when the terminal is on-line.

NOTE: After the terminal is switched from on-line to local, any data sent to the terminal from the computer is lost. If a modem is being used, communication with the computer must be restored.

#### **HERE IS**

This key causes the terminal to send an answerback message. The answerback message is selected in SET-UP. Refer to Chapter 3 for more detail.

#### **LOCAL FORM FEED**

This key advances the paper to the next top margin without sending a form feed control character to the computer.

#### **LOCAL LINE FEED**

This key advances the paper one line without sending a linefeed control character to the computer.

#### **BACKSPACE**

This key causes the terminal to generate the backspace control character.

#### **BREAK**

This key causes the terminal to transmit a short break signal with a fixed time duration. When pressed while pressing the SHIFT key, the terminal generates a long break disconnect signal. Refer to the Programmer Reference Manual for more detail on how to use the break signal.

NOTE: The BREAK key can be disabled by a SET-UP feature. Refer to Chapter 3 for more detail.

#### **DELETE**

This key causes the terminal to generate the delete control character.

#### **RETURN**

This key causes the terminal to generate either the carriage return control character or the carriage return and linefeed control characters (when the auto-linefeed feature is on). Refer to chapter 3 for more detail.

#### **LINE FEED**

This key causes the terminal to generate the linefeed control character.

#### **PF1 PF2 PF3 PF4**

These keys cause the terminal to generate escape sequences which may have special meaning to the computer.

**ENTER**

This key generates the same control character(s) as the RETURN key on the main keyboard.

NOTE: The alternate keypad feature changes the characters generated by the auxiliary keypad. Refer to Chapter 3 for more detail.

**SET-UP Keys**

The keys shaded in Figure 1-16 are used during SET-UP. The following paragraphs include a short description of each key. Before using these keys, read the detailed description of SET-UP and the SET-UP features in Chapter 3.

**SET-UP**

When pressed while pressing the CTRL key, the SET-UP key causes the terminal to enter SET-UP. When pressed while in SET-UP, the SET-UP key causes the terminal to exit SET-UP.

**SET TAB**

This key sets a horizontal tab stop at the current column when pressed alone. It sets a vertical tab stop at the current line when pressed while pressing the SHIFT key.

**CLEAR TAB**

This key clears a horizontal tab stop at the current column when pressed alone. It clears a vertical tab stop at the current line when pressed while pressing the SHIFT key.

**CLEAR ALL**

This key clears all horizontal tab stops when pressed alone. It clears all vertical tab stops when pressed while pressing the SHIFT key.

**TOF (Top of Form)**

This key selects the current paper position as the top of form (line 1).

**TOP/LEFT MAR (TOP/LEFT MARGIN)**

This key sets the left margin at the current column when pressed alone. It sets the top margin at the current position when pressed while pressing the SHIFT key.

**BOT/RT MAR (BOTTOM/RIGHT MARGIN)**

This key sets the right margin at the current column when pressed alone. It sets the bottom margin at the current position when pressed while pressing the shift key.

**MAR CLEAR (MARGIN CLEAR)**

This key clears the left and right margins when pressed alone. It clears the top and bottom margins when pressed while pressing the SHIFT key.



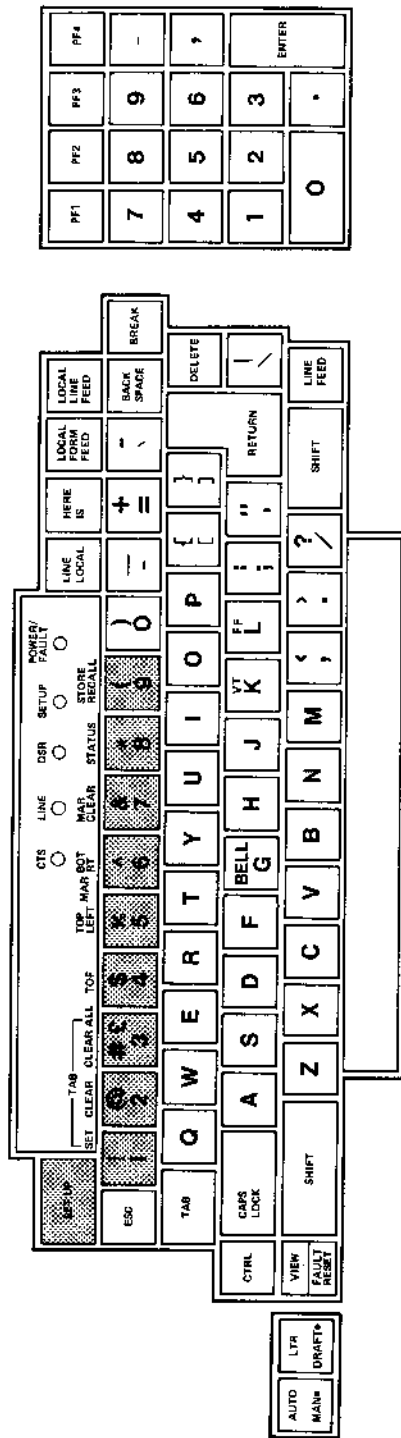

Figure 1-16 SET-UP Keys

## **STATUS**

This key causes the terminal to print the status message. The status message is a list of the currently selected SET-UP features.

## **STORE/RECALL**

This key recalls the SET-UP features stored in user permanent memory when pressed alone. It stores the contents of the operating memory into user permanent memory when pressed while pressing the SHIFT key.

## **VISUAL INDICATORS**

The following paragraphs describe the Letterwriter 100 visual indicators.

### **POWER/FAULT**

This indicator (Figure 1-17) lights when power is turned on. When power is first turned on, the POWER/FAULT and DSR (data set ready) indicators show any errors during the power-up self-test. Refer to Chapter 4 for more detail on the power-up self-test. The POWER/FAULT indicator flashes when the terminal is not ready to print for any of the following reasons.

- Paper is out or low
- Access cover is open
- Printhead is jammed (also indicated by multiple bell tones)

To correct any of these conditions refer to Chapter 4.

### **SET-UP**

This indicator (Figure 1-17) flashes when the terminal is in SET-UP. When storing the SET-UP features (in SET-UP) the indicator steadily remains on for up to 9 seconds.

### **DSR**

This indicator (Figure 1-17) lights when the terminal receives the DSR signal. It is also used with the POWER/FAULT indicator to show any errors during the power-up self-test. Refer to Chapter 4 for more detail on the power-up self-test.

### **LINE**

This indicator (Figure 1-17) lights to show that the terminal is on-line and can transmit and receive characters.

### **CTS (Clear to Send)**

This indicator (Figure 1-17) lights when the terminal receives the CTS signal.

### **Font (Part of LA10X-FL Multiple Font Option)**

These indicators (Figure 1-18) show the currently selected font. One light on indicates that the font shown is forced. One light off indicates that no font is forced. The indicator that is off also shows the currently computer selected font.

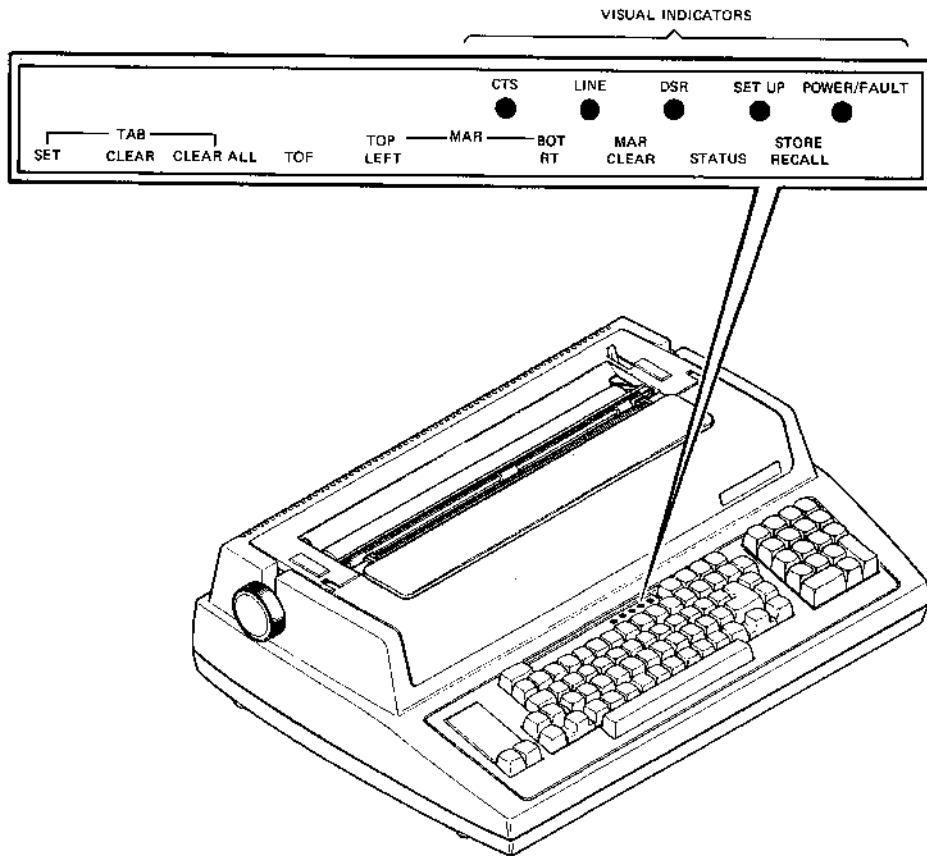

NA-7700A

Figure 1-17 Keyboard Indicators

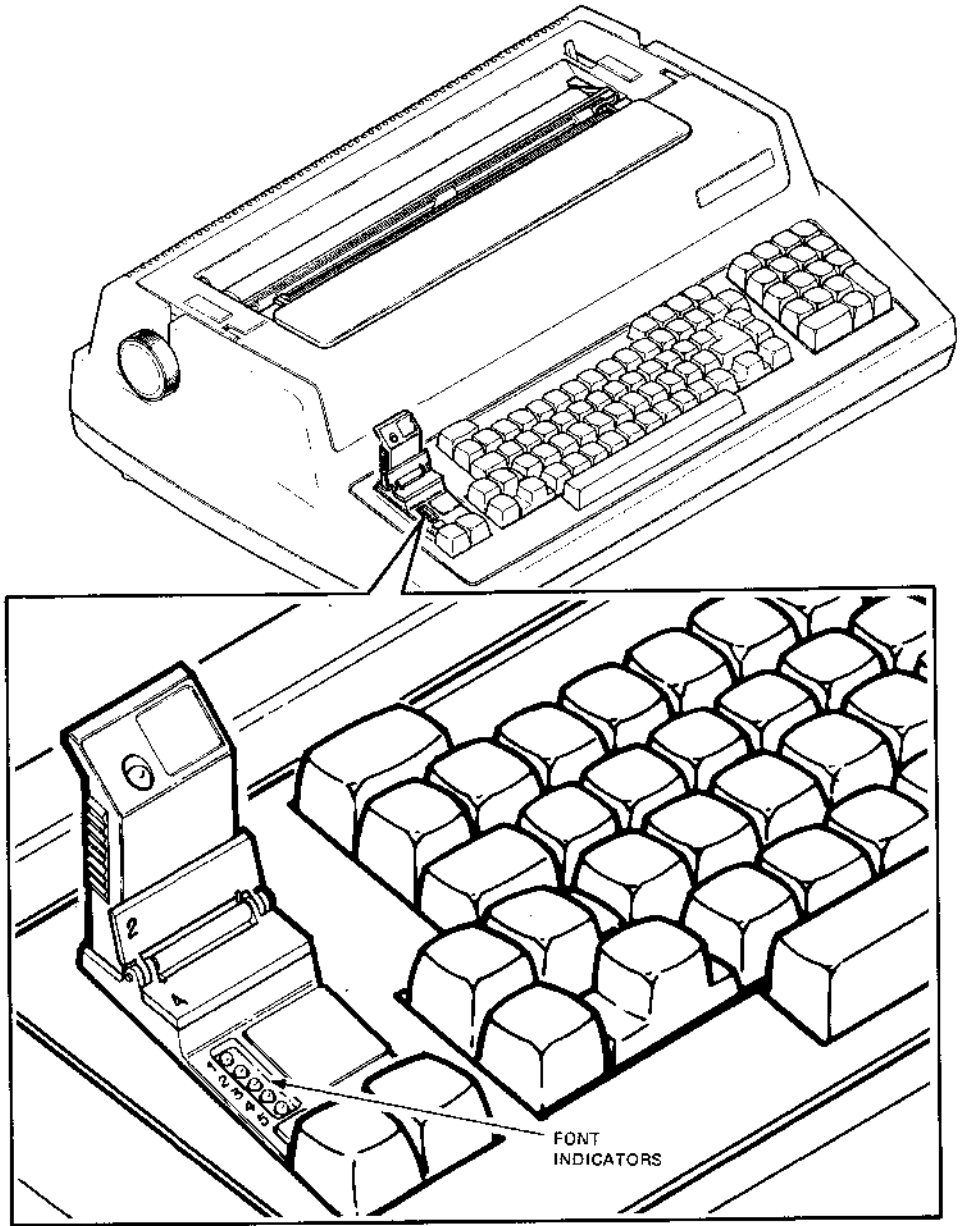

MA 7237H

Figure 1-18 Font Indicators

**ROM Cartridge (Part of ROM Cartridge Options)**

This indicator (Figure 1-19) lights when the ROM cartridge is seated correctly in the ROM cartridge socket.

**Column**

This indicator (Figure 1-20) shows the current position (column) of the printhead. Scales are provided for four of the horizontal pitch (characters per inch) selections.

**AUDIBLE INDICATORS**

Table 1-1 lists the conditions that cause a bell tone.

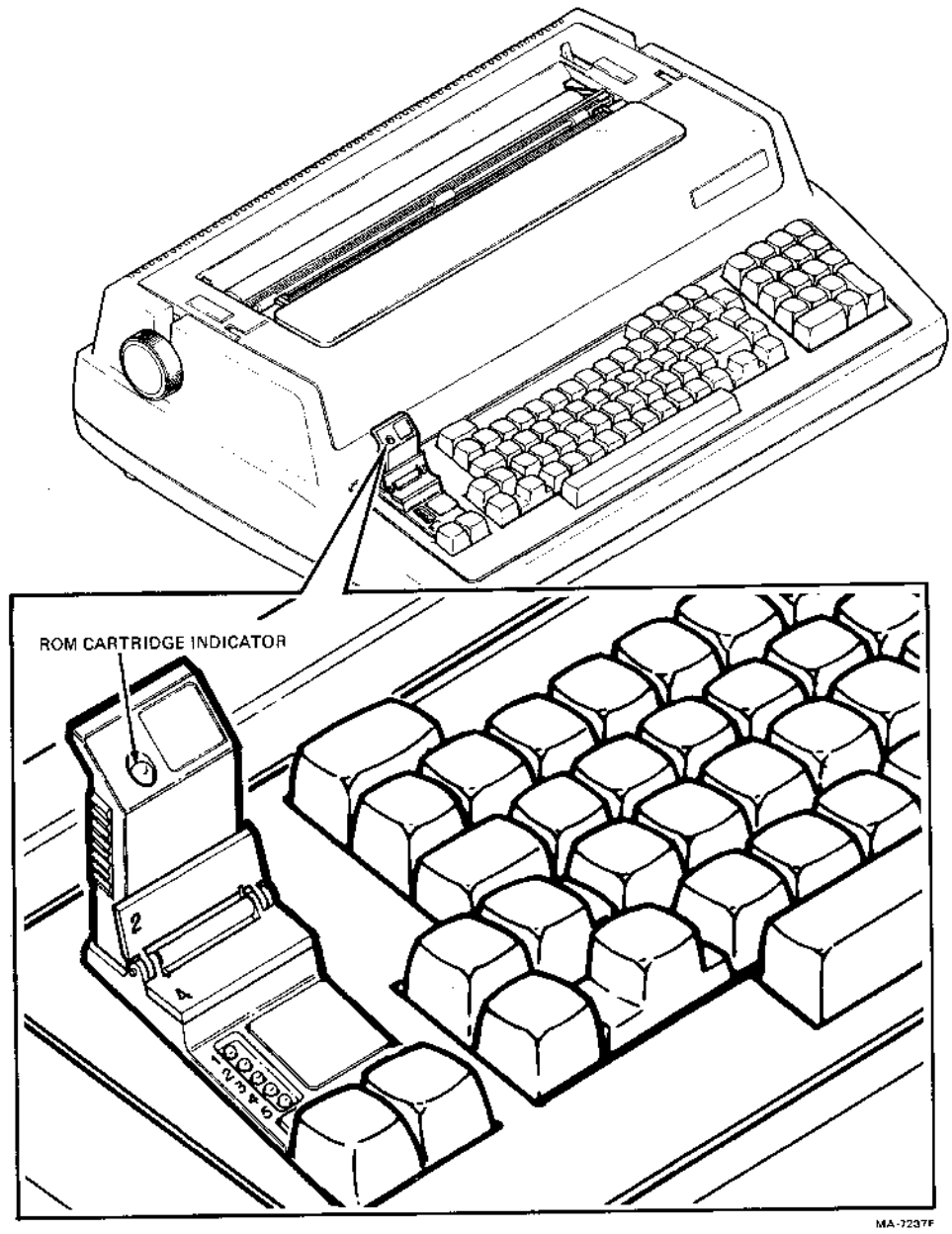
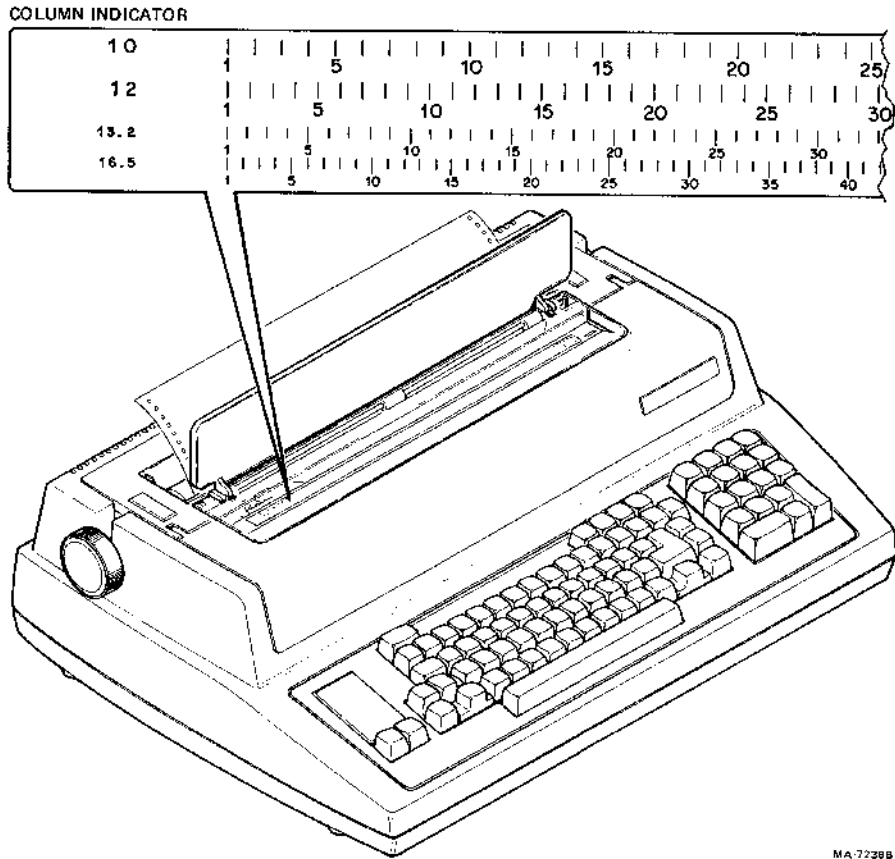

Figure 1-19 ROM Cartridge Indicator



MA-7238B

Figure 1-20 Column Indicator

Table 1-1 Audible Indicators

Cause	Action/Comment
Input buffer overflow	If terminal cannot process characters from input buffer before buffer fills, an input buffer overflow can occur. During an overflow condition, bell tone sounds and character is discarded.
Keyboard buffer overflow	Typing faster than terminal transmits characters from keyboard buffer causes a keyboard buffer overflow. When keyboard buffer is full, every character typed causes a bell tone and character is discarded. Refer to the Programmer Reference Manual for more detail.
Bell code	Each bell code received by terminal causes bell tone to sound.
Incorrect SET-UP command	An incorrect key pressed during SET-UP causes one bell tone.
Printhead jam	Indicated by multiple bell tones and a flashing POWER/FAULT indicator. To correct condition, refer to Chapter 4.



**CHAPTER 2**  
**RIBBON AND PAPER INSTALLATION**

**GENERAL**

This chapter describes how to change ribbon cartridges, load paper or preprinted forms, and adjust the printhead.

**RIBBON CARTRIDGE INSTALLATION**

The ribbon cartridge used in the Letterwriter 100 terminals usually provides 40 hours of continuous printing. Actual cartridge life depends on the type of printing done by the terminal. When the print density is too light, check the printhead adjustment (described later in this chapter). If the printhead is adjusted correctly and the print density is still too light, replace the ribbon cartridge.

CAUTION: Although you can use the DECwriter IV ribbon cartridge with the Letterwriter 100, DIGITAL recommends the Letterwriter 100 ribbon cartridge (P/N LA10R). Using other ribbon cartridges may damage the printhead and void the warranty. Refer to the Accessories and Supplies chapter for ordering information.

Perform the following procedure to install a ribbon cartridge. It is not necessary to turn the power off when installing a ribbon cartridge.

1. Open the access cover (Figure 2-1).
2. Remove (lift) and discard the old ribbon cartridge.
3. Move the printhead adjustment lever all the way to the right (Figure 2-1).
4. Turn the ribbon adjust knob on the new ribbon cartridge clockwise to tighten the ribbon (Figure 2-2).
5. Line up the snap buttons on the new ribbon cartridge with the mounting holes in the carriage assembly (Figure 2-1).
6. Slowly press the new ribbon cartridge onto the carriage assembly while turning the ribbon adjust knob. Verify that the slot in the ribbon cartridge (Figure 2-2) engages the tab on the ribbon advancing mechanism (Figure 2-1).

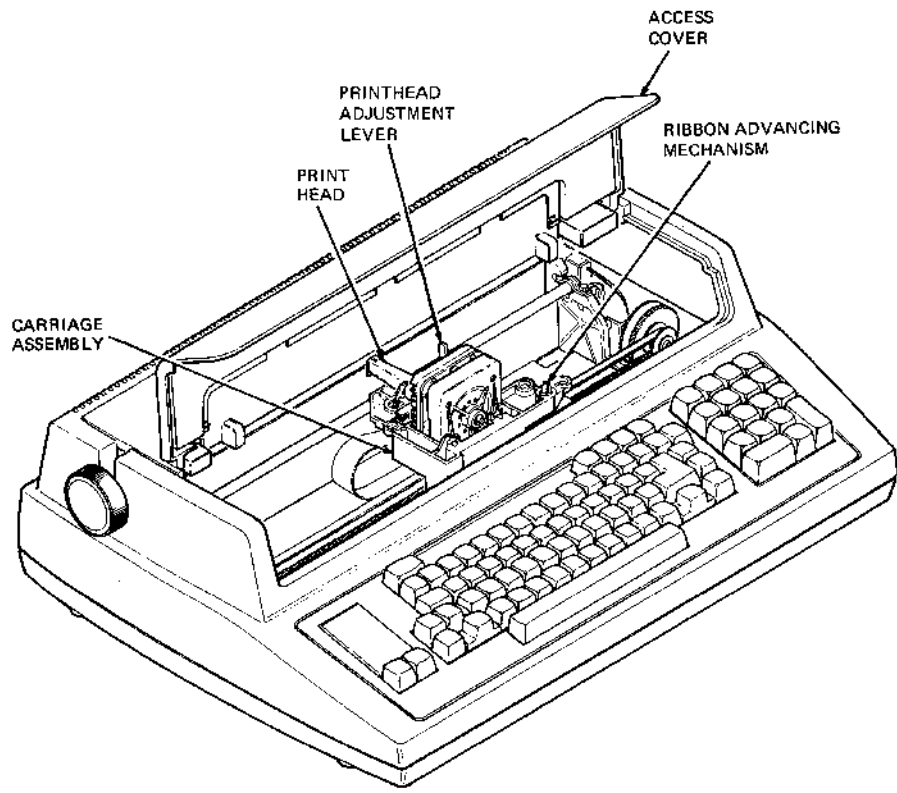

MA-72396

Figure 2-1 Carriage Assembly

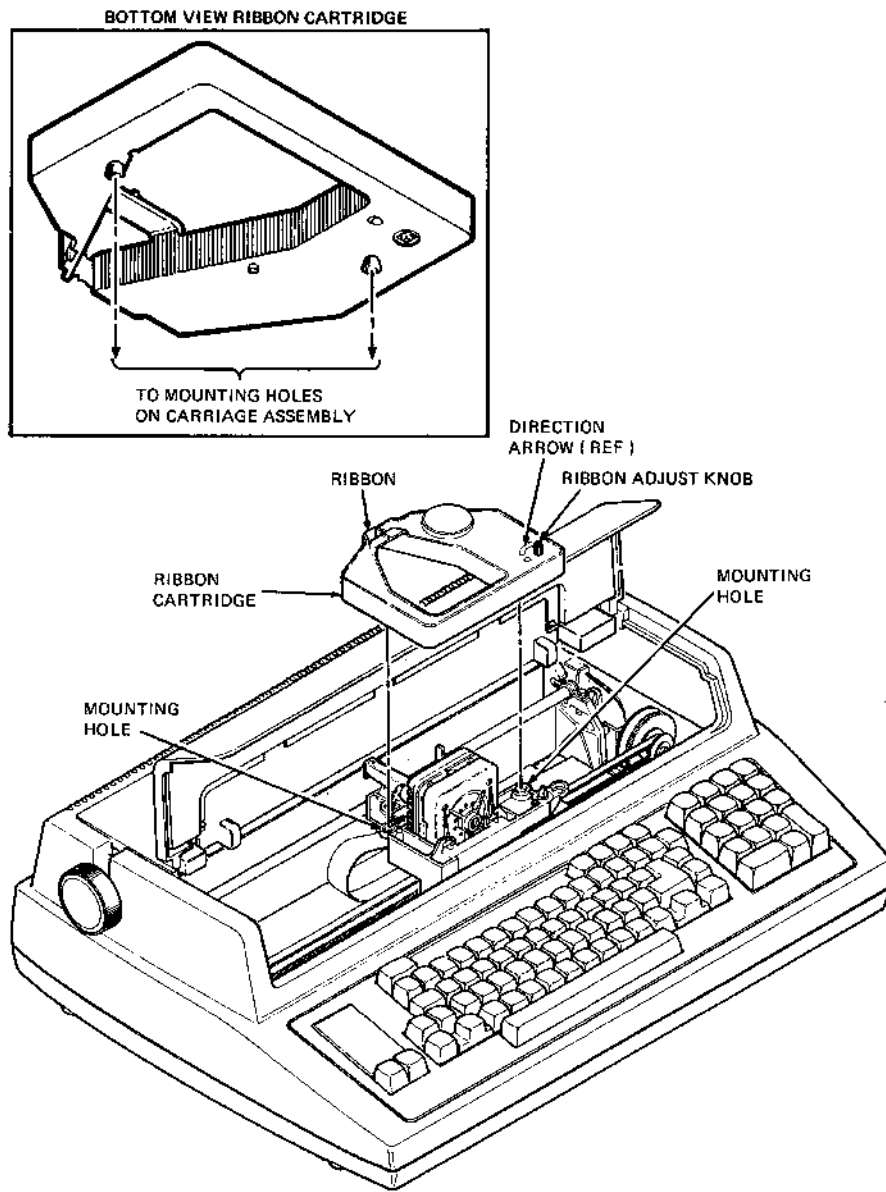

MA-7240B

**Figure 2-2 Ribbon Cartridge**

7. While watching the ribbon adjust knob, manually move the printhead to the right and left two or three times. If the ribbon adjust knob is turning in a clockwise direction when the printhead moves, the ribbon is advancing correctly.
8. Close the access cover and press the RESET key.
9. Adjust the printhead as described later in this chapter.

#### **LOADING PAPER AND PREPRINTED FORMS**

The Letterwriter 100 accepts friction feed or tractor feed paper ranging in width from 3 to 14 7/8 inches. Friction feed roll paper must be used to operate the printer as a graphics output printer. Use the following rules when selecting paper for the Letterwriter 100.

##### **Friction Feed Paper**

Observe these rules when using friction feed paper.

- Use single sheet or roll paper.
- Do not use preprinted roll paper forms.
- Do not use multipart forms.
- Do not use impact paper.
- Do not use card stock.

##### **Tractor Feed Paper**

Observe these rules when using tractor feed paper.

- Use multipart forms three or four parts only and one card part. The card must be the last part.
- Dot or line glue margins are acceptable (one margin only).
- Do not use first-surface impact paper.
- Do not use split forms (different number of sheets on each side of form).
- Do not use stapled forms.

##### **Loading Friction Feed Paper**

The following paragraphs describe how to load friction feed paper, including single sheet and roll paper. It is not necessary to turn the power off to load friction feed paper.

**Single Sheet** -- To use single sheets of paper in the Letterwriter 100, you must disable the paper out or paper low detection options (LAX34-PL or LAX34-LL) if either is installed. (To disable these options refer to the Installation Guide.) To load single sheets of paper, refer to Figures 2-3 and 2-4, and perform the following procedure.

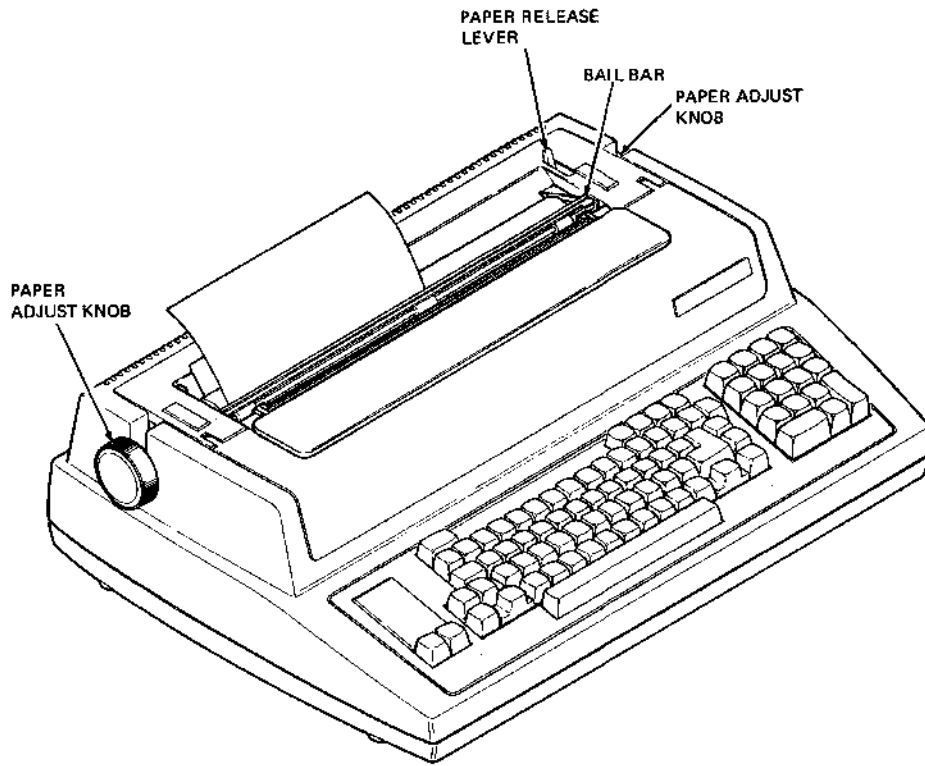

MA-7244B

**Figure 2-3 Loading Single Sheet Paper**

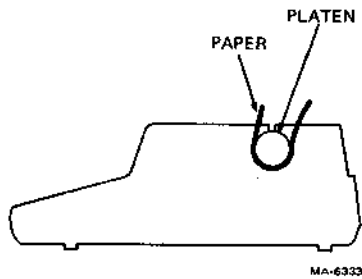

MA-6933

**Figure 2-4 Single Sheet Paper Path**

1. Feed the sheet of paper under the platen from the back. Lift the bail bar and advance the paper, using the paper advance knob, until the top edge of the paper is even with the bottom edge of the paper.
2. Pull the paper release lever toward the front of the printer and position the paper to the left of the printer (as seen from the front).
3. Smooth the paper over the surface of the platen and align the top and bottom edges.
4. Push the paper release lever toward the back of the printer and lower the bail bar to its original position.
5. If necessary, adjust the printhead as described later in this chapter.

**Roll Paper** -- The LAX34-RL roll paper holder option must be installed to use friction feed roll paper. (Refer to Installation Guide.) Perform the following procedure to load friction feed roll paper or preprinted forms into the Letterwriter 100.

1. Remove the mandrel from the roll paper holder and slide one paper roll retainer from the mandrel (Figure 2-5).
2. Remove the old roll of paper. Slide the new roll of paper onto the mandrel. Replace the paper roll retainer previously removed.
3. Reinstall the mandrel on the roll paper holder assembly so the paper feeds from the bottom of the roll (Figure 2-6).
4. Position the paper roll to the left of the holder (as seen from the front). Make sure the paper roll retainers are touching the paper roll to prevent it from moving from side to side. Do not let the paper roll retainers touch the side of the roll paper holder to create unnecessary friction.
5. Feed the paper over the roll holder apron and under the platen from the back. Lift the bail bar and advance the paper, using the paper advance knob, until the top edge extends back over the apron (Figure 2-6). Make sure the paper does not pass under the paper low sensor (Figure 2-6).
6. Pull the paper release lever toward the front of the printer (Figure 2-5). Smooth the paper over the surface of the platen and line up the sides of the paper with the supply roll edges.

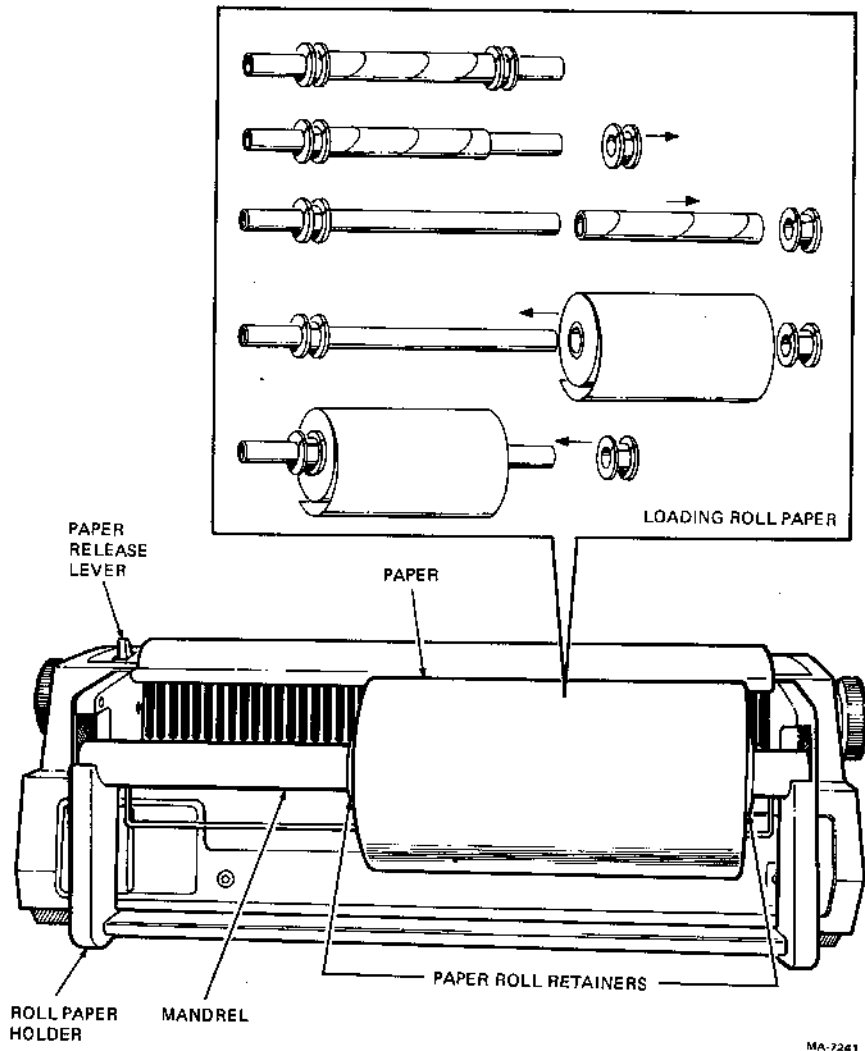

Figure 2-5 Loading Roll Paper

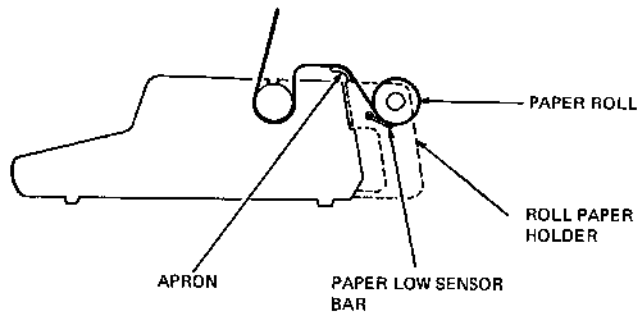

Figure 2-6 Roll Paper Path

7. Push the paper release lever toward the back of the printer and lower the bail bar to its original position.
8. Adjust the printhead as described later in this chapter.

#### **Loading Tractor Feed Paper/Forms**

The following paragraphs describe how to load tractor feed paper or preprinted forms into the Letterwriter 100. The LAX34-AL tractor option must be installed to use tractor feed paper. DIGITAL also recommends using the printer stand option (LAX34-SL) for the most effective paper feeding operation. Tractor feed paper may be loaded through the bottom or from the back of the printer. It is not necessary to turn power off when reloading tractor feed paper. Perform the following procedure to reload tractor feed paper.

NOTE: If paper is loaded from the back of the terminal, the paper out detection option does not operate.

1. Make sure that the bail bar is behind the tractors. If not, remove the tractors and reinstall according to the LAX34-AL tractor option instructions in the Installation Guide.
2. If you are using a different size paper, pull the right tractor adjust levers toward the front of the printer to loosen the right tractor (Figure 2-7).
3. Move the right tractor to the right side plate. Do not tighten the right tractor adjust lever at this time.

NOTE: Step 3 provides margins for 13.2 inch wide paper. If you are using smaller paper, move the right tractor to the place that corresponds to the size of your form. Do not move the left tractor when using smaller forms.

4. Open both tractor covers (Figure 2-7).
5. If you are not using the printer stand option, position the printer as shown in Figure 2-8. Place the back edge of the printer parallel to and slightly over the edge of the table.



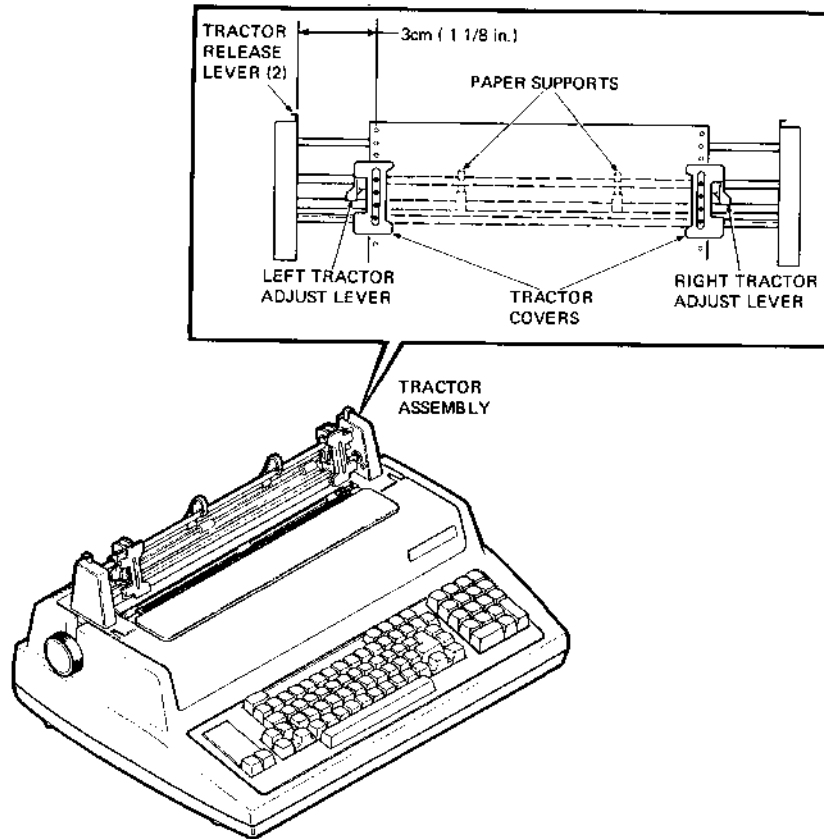

MA-7243B

Figure 2-7 Loading Tractor Feed Paper

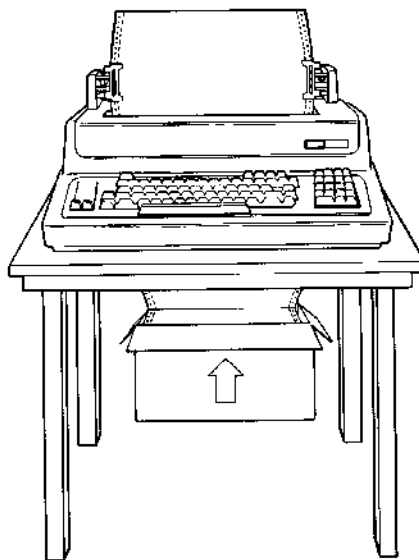
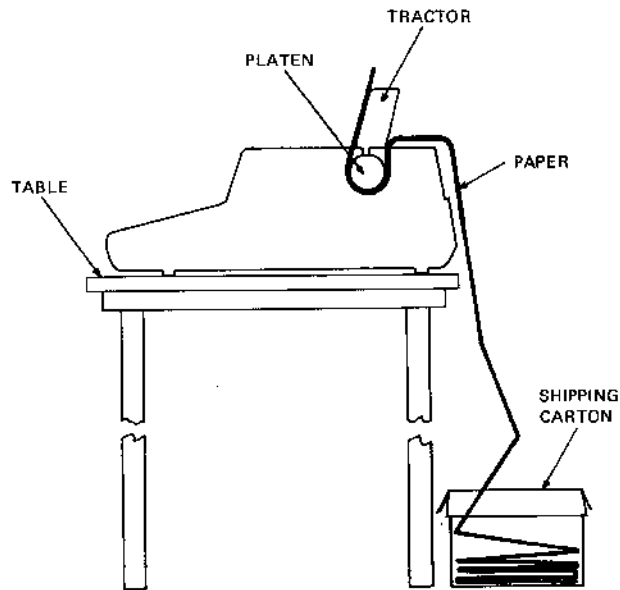

MA-7952

Figure 2-8 Tractor Feed Paper Path  
(Without Stand)

6. Position the paper to feed correctly into the printer.
  - a. If you are using the printer stand, place the paper/forms on the crossmember between the legs of the printer stand (Figure 2-9).
  - b. If you are not using the printer stand, place the paper/forms on the floor behind the table as shown in Figure 2-8. The paper can be left in the shipping container if the container top is removed.

NOTE: If it is not possible to place the paper supply on the floor, place it on the table behind the printer. However, use the LAX34-SW paper tray accessory to prevent interference between the printout and supply paper unless the printer is continuously watched.

7. Feed the paper through the paper slot.
  - a. If you are using the printer stand, align the paper parallel to the bottom paper slot and route the paper through the paper slot (Figure 2-9).

NOTE: Multipart forms might separate if loaded into the printer from the back.

- b. If you are not using the printer stand, feed the paper through the paper slot behind the platen. Rotate the paper advance knob clockwise until the top edge of the paper extends above the tractors (Figure 2-8).

NOTE: Feeding supply paper under the Letterwriter 100 and through the bottom paper slot is not recommended unless the printer stand is used. When paper is loaded from the bottom without the printer stand, the paper perforations might catch on the table and cause the terminal to print uneven lines across the paper.

8. Place the left margin holes over the tractor feed pins. Close the left tractor cover.
9. Position the right tractor to place the right margin holes over the tractor feed pins. Close the right tractor cover.
10. Tighten the right tractor adjust lever to clamp the right tractor in place.

CAUTION: Do not stretch the paper too tight. If the paper pulls against the tractor pins or is loose in the center, readjust the right tractor.

11. Position the paper supports one third of the distance from each tractor (Figure 2-7).

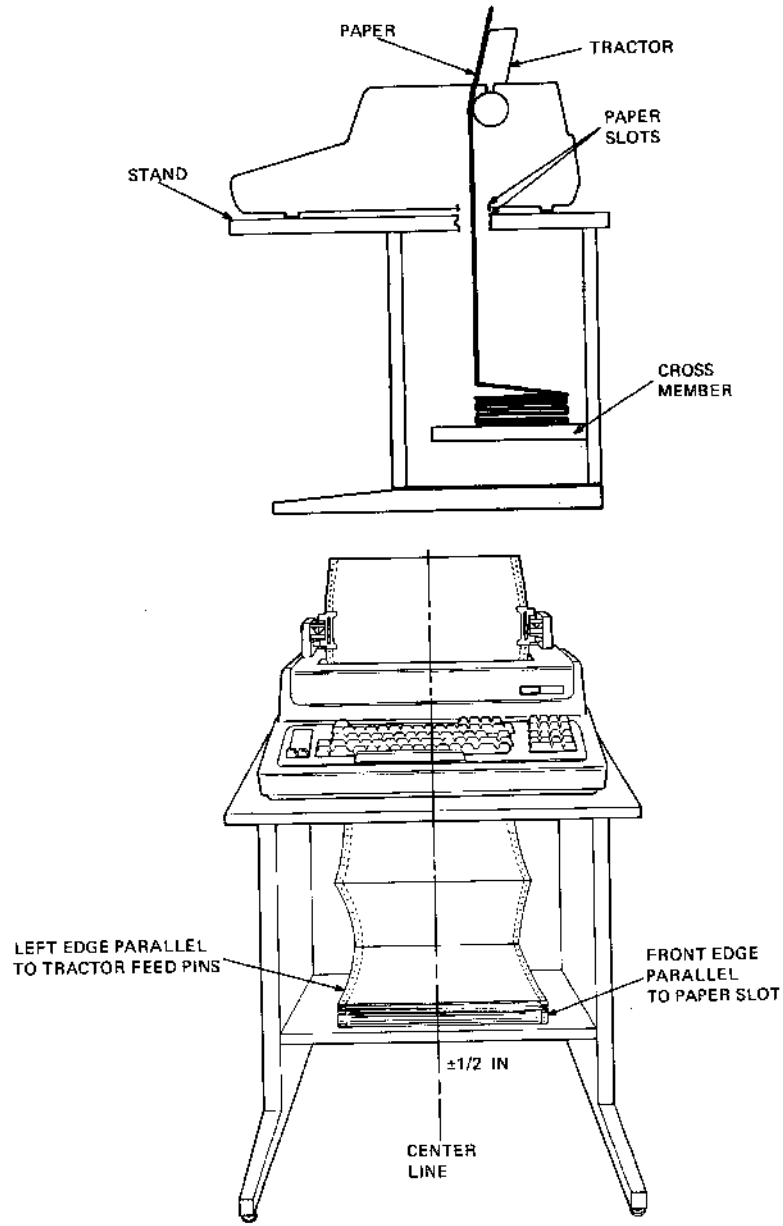

Figure 2-9 Tractor Feed Paper Path (With Stand)

12. Make sure that the paper stack is centered directly under the tractors.
13. Pull the paper release lever toward the front of the printer (Figure 2-5).
14. Adjust the printhead as described later in this chapter.

#### PRINTHEAD ADJUSTMENT

Perform the following procedure to adjust the printhead.

1. Make sure that the power ON/OFF switch is on.
2. Open the access cover and move the printhead adjustment lever all the way to the right (Figure 2-10).
3. Carefully move the printhead adjustment lever one position to the left.
4. Manually move the printhead to the right and left to check for smudging. If the ribbon smudges, first make sure that the paper is installed correctly. If the paper is installed correctly, move the printhead adjustment lever to the right until the smudging stops.
5. Close the access cover and press the **FAULT RESET** key.
6. Type a line of characters and check the printed characters for print quality.

NOTE: If the form ripples or is pulled by the printhead, the printhead is not adjusted correctly. Repeat steps 2 through 6.

7. If necessary, repeat steps 3 through 6 until the printed characters are clear and sharp.

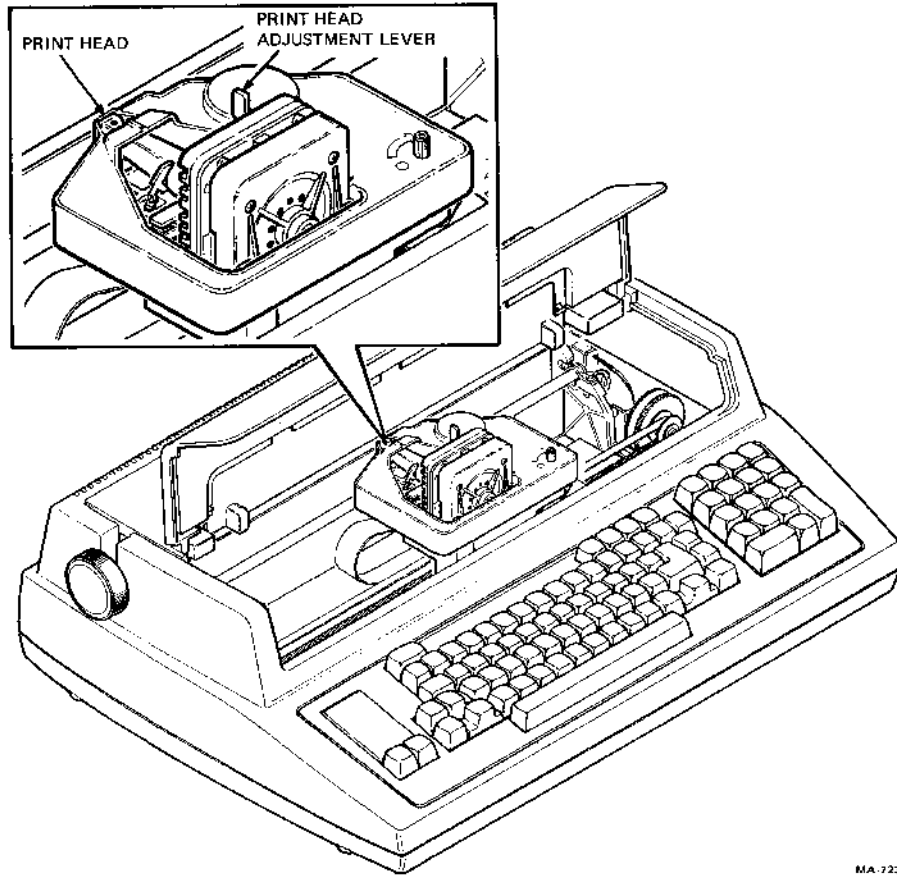

MA 7231C

Figure 2-10 Printhead Adjustment

CHAPTER 3  
OPERATOR SELECTABLE FEATURES

**GENERAL**

Letterwriter 100 terminals have many operator-selectable features (SET-UP features) that allow you to configure the terminal to meet specific applications. These features allow the terminal to handle different forms or provide computer or communication system compatibility.

This section defines SET-UP and each of the SET-UP features in detail. It is organized as follows.

- SET-UP
- Operator preference features
- Form features
- Communication compatibility features
- Feature memories
- Self-test features

**SET-UP**

The operator-selectable features can be changed only while the terminal is in SET-UP. Five steps usually are required to change or select a SET-UP feature.

1. Enter SET-UP.
2. Print a status message to check feature settings.
3. Change a feature such as tabs, baud rate, etc.
4. Store the feature if desired.
5. Exit SET-UP.

NOTE: Storing a feature saves it for future use. Refer to the Feature Memories section in this chapter for more detail.

The terminal can enter SET-UP while on-line or local. However, to prevent data loss while the terminal is on-line, enter SET-UP only while the computer is not transmitting characters or the computer recognizes a selected XON/XOFF feature.

When changing more than one SET-UP feature, it is not necessary to enter and exit SET-UP each time. Also, if you press a key that has no function in SET-UP when changing a SET-UP feature, the terminal prints a question mark (?) and a bell tone rings.

Perform the following procedure to enter and exit SET-UP.

Procedure	Indication/Comment
Press and hold CTRL down. Then press SET-UP and release both keys.	SET-UP indicator flashes, indicating terminal is in SET-UP.
Now you can change any SET-UP feature.	
Press SET-UP again to exit SET-UP.	SET-UP indicator stops flashing.

#### OPERATOR PREFERENCE FEATURES

The following paragraphs describe the operator preference features. You can use these features to configure the terminal for individual needs. Changing these features has no effect on characters transmitted or received by the terminal. You also can store the operator preference features in the terminal for future use. Refer to the Feature Memories section in this chapter for more detail.

##### Last Character View

This feature allows you to see the last character printed. After printing activity stops, the printhead moves to the right to show the last character printed and then automatically moves back to continue printing. This feature can occur automatically or only after you press the VIEW key. For your convenience, you can change the last character view feature without entering SET-UP.

Perform the following procedure to select manual or automatic last character view.

Procedure	Indication/Comment
Press and hold CTRL down. Then press VIEW and release both keys.	Terminal switches between manual and automatic last character view each time CTRL and VIEW are pressed. When printhead moves right and after VIEW is pressed, manual last character view is selected. When printhead moves right and after any printing activity stops, automatic last character view is selected (VIEW key does not function).

##### Keyclick

Keyclick is a sound generated each time a key is pressed. The SHIFT and CTRL keys do not generate keyclicks because they do not generate character codes. They modify character codes generated by other keys. Keyclick can be turned off for low noise environments.



Perform the following procedure to turn the keyclick feature on or off.

Procedure	Indication/Comment
Enter SET-UP.	SET-UP indicator flashes.
Press Q = A RETURN	Keyclick off
Press Q = B RETURN	Keyclick on
Exit SET-UP.	SET-UP indicator stops flashing.

#### FORM FEATURES

When setting up a form in a typewriter, you must position the form, set the left and right margins, and set tabs. Setting up the terminal to print forms is very similar. However, you can set the following features, too.

- Pitch mode
- Horizontal pitch
- Vertical pitch
- Form length
- Top of form
- Vertical margins
- Vertical tabs

You can store the form features in the terminal for future use.

NOTE: The computer can load form settings into the terminal automatically. Refer to the Programmer Reference Manual for more detail.

#### Recommended Sequence

Use the following recommended sequence as a guide when setting up a form. You do not have to use all of the features listed. However, you must follow the order in which the features are presented.

1. Set the pitch select mode.
2. Set the horizontal pitch.
3. Clear horizontal margins.
4. Set the left horizontal margin.
5. Clear the horizontal tabs.
6. Set the horizontal tabs.
7. Set the right horizontal margin.
8. Set the vertical pitch.
9. Set the form length.
10. Set the top of form.
11. Clear the vertical margins.
12. Set the top vertical margin.
13. Clear the vertical tabs.
14. Set the vertical tabs.
15. Set the bottom vertical margin.
16. Store the form settings.

### Pitch Select Mode

This feature selects font pitches or all pitches. When all pitch mode is selected, the terminal can print any of the eight horizontal pitch selections available. All pitch mode is useful when the terminal is used as a printer. When font pitch is selected, the terminal prints the single width pitch of the current font (10 or 12 characters per inch) or its double width (5 or 6 characters per inch) only. Font pitch mode is useful when printing draft copies of letter quality memorandums because the draft copy looks like the letter version.

Perform the following procedure to select font pitch or all pitch.

NOTE: The actual horizontal pitch used by the terminal depends on the density selection (letter or draft quality), pitch select mode, and horizontal pitch features. Refer to all three features when attempting to select horizontal pitch.

Procedure	Indication/Comment
Enter SET-UP.	SET-UP indicator flashes.
Press:	To select:
B RETURN	Prints list of pitch select mode features and current selection.
B = A RETURN	All pitch mode
B = B RETURN	Font pitch mode
Exit SET-UP.	SET-UP indicator stops flashing.

### Horizontal Pitch (Characters Per Inch)

The horizontal pitch of a character is the width of the character as well as the spacing between characters. The terminal has eight different horizontal pitch selections (Figure 3-1).

NOTE: Changing horizontal pitch resets the left margin to column one and the right margin to the maximum column for the selected pitch. Table 3-1 lists the maximum columns for each horizontal pitch.

The actual horizontal pitch used by the terminal depends on the density selection (letter or draft quality), pitch select mode, and horizontal pitch features. Refer to all three features when attempting to select horizontal pitch.

5 CHARACTERS PER INCH  
 6 CHARACTERS PER INCH  
 6.6 CHARACTERS PER INCH  
 8.25 CHARACTERS PER INCH  
 10 CHARACTERS PER INCH  
 12 CHARACTERS PER INCH  
 13.2 CHARACTERS PER INCH  
 16.5 CHARACTERS PER INCH

MA-8323

Figure 3-1 Horizontal Pitch Examples

Table 3-1 Maximum Right Margins

Horizontal Pitch	Maximum Right Margin
10	132
12	158
13.2	168
16.5	217
5	66
6	79
6.6	84
8.25	108

Perform the following procedure to set or change the horizontal pitch feature.

Procedure	Indication/Comment
Enter SET-UP.	SET-UP indicator flashes.
Press:	To select:
H RETURN	Prints list of horizontal pitch selections and current selection.
H = A RETURN	10 characters per inch
H = B RETURN	12 characters per inch
H = C RETURN	13.2 characters per inch
H = D RETURN	16.5 characters per inch
H = E RETURN	5 characters per inch
H = F RETURN	6 characters per inch
H = G RETURN	6.6 characters per inch
H = H RETURN	8.25 characters per inch
Exit SET-UP.	SET-UP indicator stops flashing.

#### Horizontal Margins And Tabs

The left margin specifies the first column in which to print and the right margin specifies the last column in which to print (Figure 3-2).

A horizontal tab stop is a preselected column to which the printhead advances when a horizontal tab control character is received (Figure 3-2). For example, if a horizontal tab stop is set at column nine and a horizontal tab control character is received, the printhead advances to column nine.

Perform the following procedures to set or clear horizontal margins and tabs.

**Clearing Horizontal Margins --** Use this procedure to clear horizontal margins.

Procedure	Indication/Comment
Enter SET-UP.	SET-UP indicator flashes.
Press & 7	Clears left and right horizontal margins.
Exit SET-UP.	SET-UP indicator stops flashing.

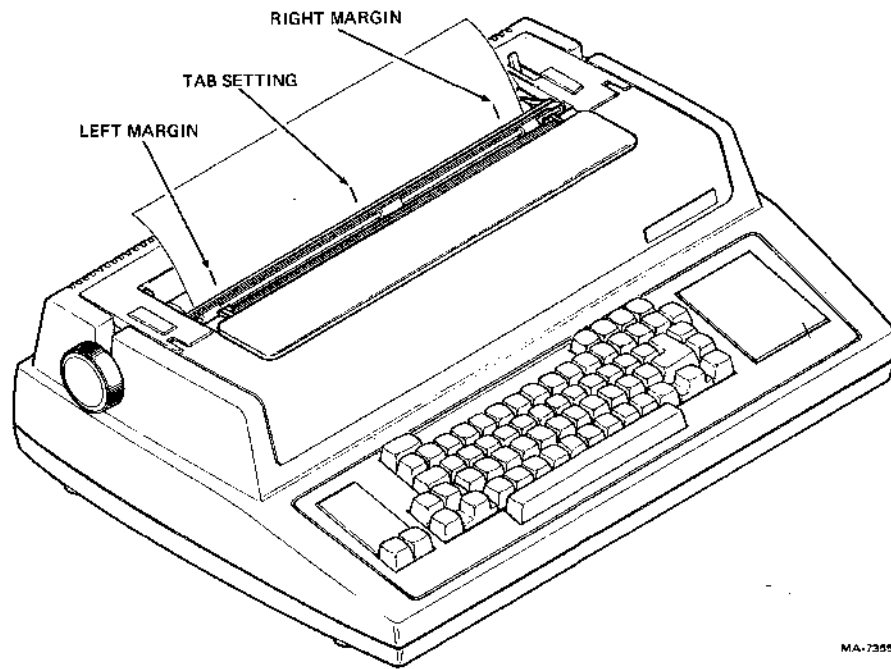

MA-7355A

**Figure 3-2 Horizontal Margins and Tabs**

**Setting Left Horizontal Margin -- Use this procedure to set left horizontal margins.**

<b>Procedure</b>	<b>Indication/Comment</b>
Enter SET-UP.	SET-UP indicator flashes.
Clear current margins if desired.	
Use space bar to advance printhead to desired column.	
Press $\frac{4}{5}$	Sets left margin.
Exit SET-UP.	SET-UP indicator stops flashing.

**Clearing A Single Horizontal Tab -- Use this procedure to clear a single horizontal tab.**

<b>Procedure</b>	<b>Indication/Comment</b>
Enter SET-UP.	SET-UP indicator flashes.
Press TAB to move printhead to desired tab stop.	Printhead advances to horizontal horizontal tab stop.
Press $\frac{0}{2}$	Clears horizontal tab.
Exit SET-UP.	SET-UP indicator stops flashing.

**Clearing All Horizontal Tabs -- Use this procedure to clear all horizontal tabs.**

<b>Procedure</b>	<b>Indication/Comment</b>
Enter SET-UP.	SET-UP indicator flashes.
Press $\frac{4}{3}$	Clears all horizontal tab stops.
Exit SET-UP.	SET-UP indicator stops flashing.

**Setting Horizontal Tabs** -- Use this procedure to set horizontal tabs.

Procedure	Indication/Comment
Enter SET-UP.	SET-UP indicator flashes.
Clear horizontal tab stops if desired.	
Use space bar to advance printhead to desired column.	
Press ! 1	Sets tab.
Repeat last two steps for each additional tab stop.	
Exit SET-UP.	SET-UP indicator stops flashing.

**Setting Right Horizontal Margin** -- Use this procedure to set right horizontal margins.

Procedure	Indication/Comment
Enter SET-UP.	SET-UP indicator flashes.
Clear current margins if desired.	
Use space bar to advance printhead to desired column.	
Press ^ 6	Sets right margin.
Exit SET-UP.	SET-UP indicator stops flashing.

#### Vertical Pitch (Lines Per Inch)

Vertical pitch is the spacing between lines, not the height of the printed characters. The terminal has six different vertical pitch selections (Figure 3-3). This feature allows the terminal to print on a large number of different forms.

Changing vertical pitch changes the:

- Number of lines per page
- Active line (takes affect after first vertical motion command and pitch change)
- Action of vertical margin command





- Position of last printed line (always above bottom margin)
- Position of vertical tabs.

Changing vertical pitch does not change the:

- Top of form
- Form length
- Top margin (first line always printed at same position)
- Bottom margin (last line never printed below bottom margin).

Perform the following procedure to select or change the vertical pitch feature.

Procedure	Indication/Comment
Count number of lines per inch on your form (Figure 3-4).	
Enter SET-UP.	SET-UP indicator flashes.
Set terminal to desired number of lines per inch.	
Press:	To select:
V RETURN	Prints list of vertical pitch selections and current selection.
V = A RETURN	6 lines per inch
V = B RETURN	8 lines per inch
V = C RETURN	12 lines per inch
V = D RETURN	2 lines per inch
V = E RETURN	3 lines per inch
V = F RETURN	4 lines per inch
Exit SET-UP.	SET-UP indicator stops flashing.

#### Form Length

The form length is measured in 1/24 inch lines. The form length can be no longer than 21 inches. To set form length, first make sure the terminal is at the top of form.

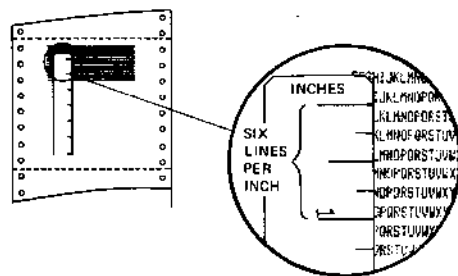

MA-7713A

Figure 3-4 Selecting Vertical Pitch

Perform the following procedure to set form length.

Procedure	Indication/Comment
Measure length of form in inches.	
Multiply result by 24.	
Enter SET-UP.	SET-UP indicator flashes.
Press F RETURN	Prints current form length value.
Press F = n RETURN	Substitutes numeric result obtained in first two steps for n.
Exit SET-UP.	SET-UP indicator stops flashing.

#### Top of Form (TOF)

The top of the form (TOF) is the physical top edge of the paper and line one of the paper. Do not confuse the top of form with the top margin. The top margin is the line where you want printing to begin (Figure 3-5).

NOTE: To avoid losing the TOF setting when reloading paper, the terminal assumes a loading at TOF. Once the fault is cleared, the terminal automatically repositions itself.

Once TOF is defined, you should avoid using the paper adjust knobs to advance the paper. You should use these knobs only to set TOF because any other use loses TOF.

Perform the following procedure to set TOF.

Procedure	Indication/Comment
Enter SET-UP.	SET-UP indicator flashes.
Use paper adjust knob to set form perforation even with top of printhead (Figure 3-5).	
Press \$ 4	Sets TOF. If top margin is not set to line one, paper immediately advances to top margin.
Exit SET-UP.	SET-UP indicator stops flashing.

#### Vertical Margins and Tabs

The top margin is the line where you want printing to begin. The bottom margin is the line where you want printing to end (Figure 3-5). Setting vertical margins does not change the top of form or form length.

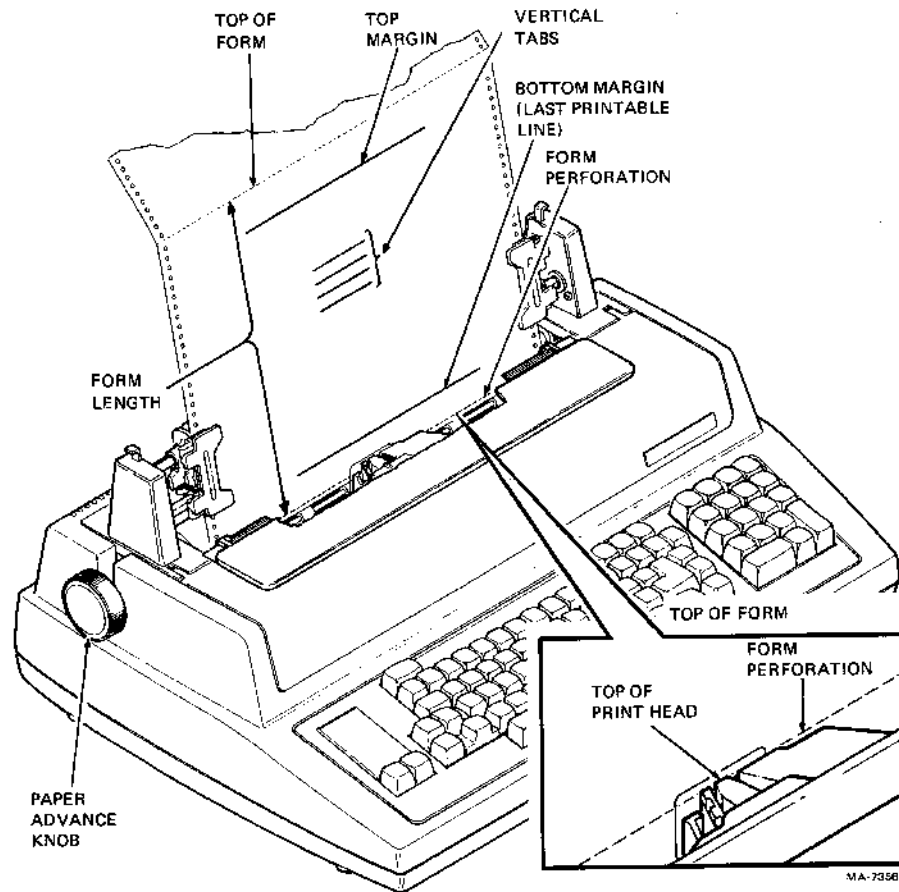

Figure 3-5 Vertical Form Settings

NOTE: Printing always starts the same distance from the top of form, no matter what vertical pitch is used. However, printing stops a variable distance from the bottom of the form, depending on the vertical pitch. Printing never occurs above the top margin or below the bottom margin.

A vertical tab is a preselected line to which the printhead advances when the terminal receives a vertical tab control character (Figure 3-5). You can set or clear vertical tabs anytime. However, when setting up a new form, the best time to set tabs is after setting the top margin.

Perform the following procedures to set or change the vertical margins or tabs features.

NOTE: The actual position of the vertical tab changes with each vertical pitch change.

**Clearing Vertical Margins --** Use this procedure to clear vertical margins.

Procedure	Indication/Comment
Enter SET-UP.	SET-UP indicator flashes.
While pressing SHIFT, press & 7	Clears top and bottom vertical margins.
Exit SET-UP.	SET-UP indicator stops flashing.

**Setting Top Vertical Margin --** Use this procedure to set top vertical margins.

Procedure	Indication/Comment
Enter SET-UP.	SET-UP indicator flashes.
Clear old vertical margins.	
Press LOCAL LINE FEED to advance paper to desired line.	

NOTE: If you can not select the exact margin location you want, you might have to change the vertical pitch.

While pressing SHIFT, press & 5	Sets top margin at current line.
Exit SET-UP.	SET-UP indicator stops flashing.

Clearing A Single Vertical Tab -- Use this procedure to clear single vertical tab.

Procedure	Indication/Comment
Enter SET-UP.	SET-UP indicator flashes.
While pressing CTRL, press K	Form advances to vertical tab stop.
While pressing SHIFT, press @ 2	Clears vertical tab.
Exit SET-UP.	SET-UP indicator stops flashing.

Clearing All Vertical Tabs -- Use this procedure to clear all vertical tabs.

Procedure	Indication/Comment
Enter SET-UP.	SET-UP indicator flashes.
While pressing SHIFT, press # 3	Clears vertical tabs.
Exit SET-UP.	SET-UP indicator stops flashing.

Setting Vertical Tabs -- Use this procedure to set vertical tabs.

Procedure	Indication/Comment
Enter SET-UP.	SET-UP indicator flashes.
Press LOCAL LINE FEED to advance paper to line requiring a tab.	
While pressing SHIFT, press ! 1	Sets tab.
Repeat last two steps for each additional tab.	
Exit SET-UP.	SET-UP indicator stops flashing.

Setting Bottom Vertical Margin -- Use this procedure to set bottom vertical margins.

Procedure	Indication/Comment
Enter SET-UP.	SET-UP indicator flashes.
Press LOCAL LINE FEED to advance paper to desired line.	
While pressing SHIFT, press <sup>^</sup> 6	Sets bottom margin.
Exit SET-UP.	SET-UP indicator stops flashing.

#### COMMUNICATION COMPATIBILITY FEATURES

To transmit and receive data, the terminal must be compatible with the computer and the communication system. Therefore, the communication features are usually preset and should not be changed unless compatibility is verified.

NOTE: Also refer to the Programmer Reference Manual for additional information about communication features.

This section describes the following features in detail.

- Parity and data bits
- Receiver error processing
- Baud rate
- Modem control
- Paper fault
- Coded disconnect
- Local echo
- Auto-XON/XOFF
- Answerback
- Auto-answerback
- End of line control
- Printer new line
- Printer character set
- BREAK key
- Alternate keypad
- Auto-linefeed
- Keyboard layout

#### Parity and Data Bits

The parity and data bits procedure selects two separate but related features, data bits per character and parity. The data bits per character can be set to 7 or 8 data bits per character. Parity selects the type of parity bit that the terminal generates for transmitted and received characters. (Also see Receiver Error Processing).

Perform the following procedure to change the parity or data bit feature.

Procedure	Indication/Comment
Enter SET-UP.	SET-UP indicator flashes.
Press:	To select:
P RETURN	Prints selections and current setting.
P = A RETURN	No parity, 7 data bits, sets 8th bit to mark
P = B RETURN	Even parity, 7 data bits
P = C RETURN	No parity, 7 data bits, sets 8th bit to space
P = D RETURN	Odd parity, 7 data bits
P = E RETURN	Even parity, 8 data bits
P = F RETURN	Odd parity, 8 data bits
Exit SET-UP.	SET-UP indicator stops flashing.

#### Receiver Error Processing

This feature determines the terminal response to an error (e.g., parity error, UART overrun, framing error). When this feature is on and an error occurs, the terminal prints the substitute control character ( **␣** ). When this feature is off, the terminal tries to print characters as received.

Perform the following procedure to enable or disable receiver error processing.

Procedure	Indication/Comment
Enter SET-UP.	SET-UP indicator flashes.
Press R RETURN	Prints list of selections and current setting.
Press R = A RETURN	Prints substitute control character ( <b>␣</b> ) when error occurs.
Press R = B RETURN	Prints characters as received.
Exit SET-UP.	SET-UP indicator stops flashing.

#### Baud Rate (Speed)

Baud rate is the speed at which the terminal transmits and receives characters. In some systems, transmit and receive speeds might be different. This difference is known as split baud rate.



Perform the following procedure to set the baud rate.

Procedure	Indication/Comment
Enter SET-UP.	SET-UP indicator flashes.
Press:	To select:
S RETURN	Prints available selections and current setting.
S = A RETURN	50 baud
S = B RETURN	75 baud
S = C RETURN	110 baud
S = D RETURN	134.5 baud
S = E RETURN	150 baud
S = F RETURN	200 baud
S = G RETURN	300 baud
S = H RETURN	600 baud
S = I RETURN	1200 baud
S = J RETURN	1800 baud
S = K RETURN	2400 baud
S = L RETURN	4800 baud
S = M RETURN	7200 baud
S = N RETURN	9600 baud
S = O RETURN	75 baud send/600 baud receive
S = P RETURN	75 baud send/1200 baud receive
S = Q RETURN	150 baud send/600 baud receive
S = R RETURN	150 baud send/1200 baud receive
S = S RETURN	300 baud send/2400 baud receive
S = T RETURN	300 baud send/4800 baud receive
S = U RETURN	600 baud send/2400 baud receive
S = V RETURN	600 baud send/4800 baud receive
Exit SET-UP.	SET-UP indicator stops flashing.

#### Modem Control

This feature controls the Electronic Industry Association (EIA) control lines that communicate with the computer. The actual lines controlled by each feature are described in the Programmer Reference Manual. Perform the following procedure to select the modem control feature.

Procedure	Indication/Comment
Enter SET-UP.	SET-UP indicator flashes.
Press Z = A RETURN	No modem control, restraint mode
Press Z = B RETURN	No modem control, speed control mode
Press Z = C RETURN	Modem control, restraint mode
Press Z = D RETURN	Modem control, speed control mode
Exit SET-UP.	SET-UP indicator stops flashing.

### Paper Fault

The paper fault feature describes the action the terminal takes when a paper fault occurs. A paper fault can be detected only when the paper out (LAX34-PL) or paper low (LAX34-LL) detection option is installed. (See Installation Guide.)

Four responses are available: no action, send break, disconnect, and do not answer.

A no action response is selected usually for hardwire installations or when no disconnect is desired. When no action is selected the terminal stops printing. If the XON/XOFF feature is on or restraint is selected and the buffer fills, the terminal sends a device control 3 XOFF to the computer or turns the busy line off.

A send break response causes the terminal to transmit a 275 ms + 25 ms BREAK signal when a paper fault occurs.

Disconnect causes the terminal to turn the data terminal ready (DTR) signal off immediately.

The do not answer response is used with the roll paper holder. This response allows the terminal to complete any call in progress. When the call is completed, the terminal disconnects (turns DTR signal off) and does not answer any new calls.

Perform the following procedure to select a paper fault response.

Procedure	Indication/Comment
Enter SET-UP.	SET-UP indicator flashes.
Press 0 = A RETURN	No action
Press 0 = B RETURN	Send break
Press 0 = C RETURN	Disconnect
Press 0 = D RETURN	Do not answer
Exit SET-UP.	SET-UP indicator stops flashing.

### Coded Disconnect

When this feature is selected and the DECwriter V receives the end of transmission (EOT) control character, the terminal disconnects from the communication line. When this feature is off, the terminal ignores the EOT control character.

Perform the following procedure to turn coded disconnect on or off.

Procedure	Indication/Comment
Enter SET-UP.	SET-UP indicator flashes.
Press N = A RETURN	Coded disconnect off (ignore EOT)
Press N = B RETURN	Coded disconnect on (disconnect upon receiving EOT)
Exit SET-UP.	SET-UP indicator stops flashing.

#### Local Echo

When the local echo feature is on, every character sent to the computer is also printed by the terminal (Figure 3-6). If local echo is off, characters are transmitted only. The computer must transmit (echo) the characters back to the terminal for printing when the local echo feature is off.

NOTE: If the terminal prints double characters turn the local echo feature off. The computer is performing the echo function.

NOTE: Enquiry (ENQ) characters are never echoed.

Perform the following procedure to turn the local echo feature on or off.

Procedure	Indication/Comment
Enter SET-UP.	SET-UP indicator flashes.
Press E RETURN	Prints list of available selections and current setting.
Press E = A RETURN	Local echo off
Press E = B RETURN	Local echo on
Exit SET-UP.	SET-UP indicator stops flashing.

#### Auto-XON/XOFF

The auto-XON/XOFF feature prevents the loss of received characters. When auto-XON/XOFF is on, the terminal transmits the device control 3 XOFF and device control 1 XON control characters to indicate when the input buffer is almost empty or full. The device control 3 XOFF character requests the computer to stop sending characters. The device control 1 XON character requests the computer to continue sending characters.

NOTE: The auto-XON/XOFF feature should be changed only when your system is not sending data.

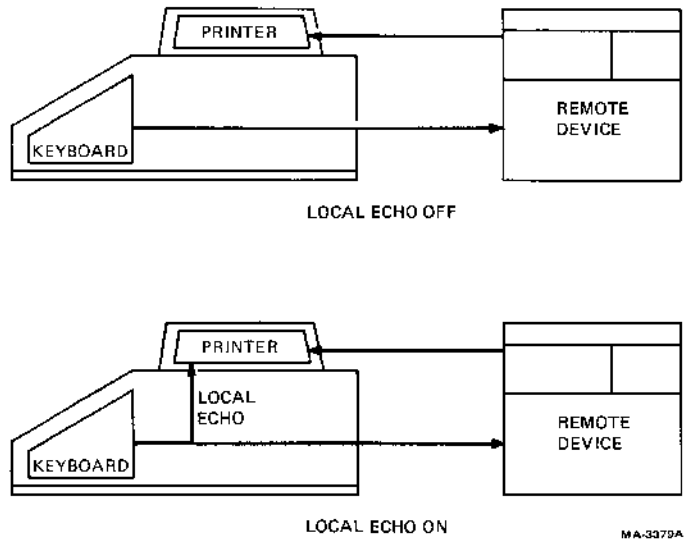

Figure 3-6 Local Echo Feature

Perform the following procedure to select or disable the auto-XON/XOFF feature.

Procedure	Indication/Comment
Enter SET-UP.	SET-UP indicator flashes.
Press X RETURN	Numeric display shows current selection of XON/XOFF.
Press X = A RETURN	Auto-XON/XOFF off
Press X = B RETURN	Auto-XON/XOFF on
Exit SET-UP.	SET-UP indicator stops flashing.

#### Answerback

Answerback is a message of up to 30 characters that identifies the terminal for the computer. You enter the answerback message into the terminal. This message is transmitted from the terminal upon the computer's request or when you press the **HERE IS** key. Printable and control characters can be part of the answerback message.

After entering and testing the answerback message, you can protect the message by setting a switch (Figure 3-7) on the logic board to prevent the message from being changed or erased. (Refer to the Installation Guide for more detail.)

**Entering/Deleting the Answerback Message --** Perform the following procedure to enter or delete the answerback message.

Procedure	Indication/Comment
Enter SET-UP.	SET-UP indicator flashes.
Press M =	Next character typed starts the answerback message.
Type message delimiter	Message delimiter can be any American Standard Code for Information Interchange (ASCII) character, including control characters. Message delimiter is not part of answerback message.
Type up to 30 characters for answerback message.	Answerback message can be any ASCII character, including control characters.

NOTE: If more than 30 characters are typed after the message delimiter, the extra characters are entered into the 30th character position.

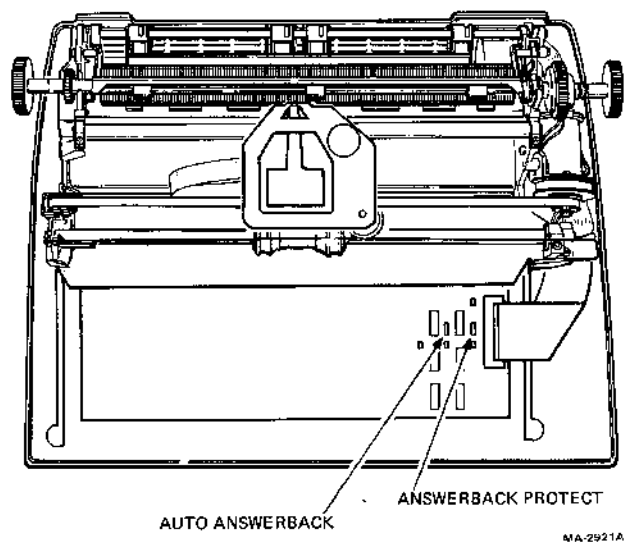

Figure 3-7 Answerback Message Protect Jumper



Perform the following procedure to turn end of line control on or off.

Procedure	Indication/Comment
Enter SET-UP.	SET-UP indicator flashes.
Press J RETURN	Prints available selections and current setting.
Press J = A RETURN	Off
Press J = B RETURN	On
Exit SET-UP.	SET-UP indicator stops flashing.

#### Printer New Line

This feature controls the terminal's response to a received linefeed or carriage return control character. The Letterwriter 100 responds in one of three different ways as described in Table 3-2.

Table 3-2 Printer New Line Selections

Selected Feature	Received Carriage Return Control Character	Received Linefeed Control Character
No new line	Terminal performs carriage return.	Terminal performs linefeed.
Linefeed new line	Terminal performs carriage return.	Terminal performs carriage return and linefeed.
Carriage return new line	Terminal performs carriage return and linefeed.	Terminal performs linefeed.



Perform the following procedure to select or change the printer new line feature.

Procedure	Indication/Comment
Enter SET-UP.	SET-UP indicator flashes.
Press W RETURN	Prints available selections and current selection.
Press W = A RETURN	No new line
Press W = B RETURN	Linefeed new line
Press W = C RETURN	Carriage return new line
Exit SET-UP.	SET-UP indicator stops flashing.

#### Printer Character Set

The character sets primarily are language sets, except for the VT100 line drawing set. The character sets that the terminal can print depend on the font the terminal is using and the selected character set. If the currently used font contains the selected character set, that character set is used. If the currently used font does not contain the selected character set, the default character set for that font is used.

The standard fonts contain the following character sets.

- ISO\* United Kingdom
- ASCII United States
- DIGITAL Finnish
- DIGITAL Norwegian/Danish
- DIGITAL Swedish
- ISO German
- DIGITAL French Canadian
- ISO French
- ISO Italian
- ISO Spanish
- DIGITAL VT100 line drawing set

Two of these character sets can be active anytime with one as G0 and the other G1. Once the character sets are designated, a single control character is used to switch between the active character sets. The shift in (SI, octal 017) control character selects the G0 character set. The shift out (SO, octal 016) control character selects the G1 character set.

NOTE: The printer character sets can be designated by the computer also. Refer to the Programmer Reference Manual for more detail.

---

\* International Standards Organization

Perform the following procedure to change the G0 or G1 character sets.

Procedure	Indication/Comment
Enter SET-UP.	SET-UP indicator flashes.
Press:	To select the G0 character set:
C RETURN	Prints available character sets and current selection.
C = B RETURN	United States (ASCII)
C = A RETURN	United Kingdom
C = 9 RETURN	French Canadian
C = K RETURN	German
C = 7 RETURN	Swedish
C = R RETURN	French
C = 5 RETURN	Finnish
C = 6 RETURN	Norwegian/Danish
C = Ø RETURN	VT100 line drawing set
C = Y RETURN	Italian
C = Z RETURN	Spanish
Press:	To select the G1 character set:
D RETURN	Prints available character sets and current selection.
D = B RETURN	United States (ASCII)
D = A RETURN	United Kingdom
D = 9 RETURN	French Canadian
D = K RETURN	German
D = 7 RETURN	Swedish
D = R RETURN	French
D = 5 RETURN	Finnish
D = 6 RETURN	Norwegian/Danish
D = Ø RETURN	VT100 Line Drawing Set
D = Y RETURN	Italian
D = Z RETURN	Spanish
Exit SET-UP.	SET-UP indicator stops flashing.

#### BREAK Key

The BREAK key feature allows you to turn the BREAK key on or off.

Pressing the BREAK key generates a break signal. A break signal is a transmitted space condition for 0.250 seconds.

Pressing the BREAK key while holding the SHIFT key down generates a long break disconnect. A long break disconnect is a transmitted space condition for approximately 3.8 seconds.

NOTE: The BREAK key feature does not affect the terminal response to a fault condition when the terminal is set to send a break signal. Refer to the paper fault feature in this chapter for more detail.

Perform the following procedure to turn the BREAK key on or off.

Procedure	Indication/Comment
Enter SET-UP.	SET-UP indicator flashes.
Press U RETURN	Prints selections and current status.
Press U = A RETURN	BREAK key on
Press U = B RETURN	BREAK key off
Exit SET-UP.	SET-UP indicator stops flashing.

#### Alternate Keypad

This feature allows the auxiliary keypad to generate characters or escape sequences. Table 3-3 lists the characters and escape sequences the keypad transmits when alternate keypad is on and off.

NOTE: When alternate keypad is on and the terminal is in local mode, the auxiliary keypad does not function.

Perform the following procedure to turn alternate keypad on or off.

Procedure	Indication/Comment
Enter SET-UP.	SET-UP indicator flashes.
Press Y RETURN	Prints selections and current status.
Press Y = A RETURN	Alternate keypad off (keypad in numeric mode)
Press Y = B RETURN	Alternate keypad on (keypad in function mode)
Exit SET-UP.	SET-UP indicator stops flashing.

Table 3-3 Auxiliary Keypad Characters and Escape Sequences

Key	Character Transmitted with Alternate Keypad Off	Character Transmitted with Alternate Keypad On
Enter	CR or CR LF Ø15 or Ø15 Ø12	ESC O M Ø33 117 115
'	' Ø54	ESC O l Ø33 117 154
-	- Ø55	ESC O m Ø33 117 155
.	. Ø56	ESC O n Ø33 117 156
Ø	Ø Ø6Ø	ESC O p Ø33 117 16Ø
1	1 Ø61	ESC O q Ø33 117 161
2	2 Ø62	ESC O r Ø33 117 162
3	3 Ø63	ESC O s Ø33 117 163
4	4 Ø64	ESC O t Ø33 117 164
5	5 Ø65	ESC O u Ø33 117 165
6	6 Ø66	ESC O v Ø33 117 166
7	7 Ø67	ESC O w Ø33 117 167
8	8 Ø7Ø	ESC O x Ø33 117 17Ø
9	9 Ø71	ESC O y Ø33 117 171
PF1	ESC O P Ø33 117 12Ø	ESC O P Ø33 117 12Ø
PF2	ESC O Q Ø33 117 121	ESC O Q Ø33 117 121

Table 3-3 Auxiliary Keypad Characters and Escape Sequences (Cont)

Key	Character Transmitted with Alternate Keypad Off	Character Transmitted with Alternate Keypad On
PF3	ESC O R Ø33 117 122	ESC O R Ø33 117 122
PF4	ESC O S Ø33 117 123	ESC O S Ø33 117 123

### Auto-Linefeed

NOTE: Do not confuse auto-linefeed with end of line control and printer new line.

This feature changes the characters generated by the RETURN and ENTER keys. When auto-linefeed is off and the RETURN or ENTER key is pressed, the terminal generates a carriage return control character. When auto-linefeed is on, the terminal generates the carriage return and linefeed control characters.

NOTE: If the terminal performs double-linefeeds, turn the auto-linefeed feature off. The computer is performing the function.

Perform the following the following procedure to turn auto-linefeed on or off.

Procedure	Indications/Comment
Enter SET-UP.	SET-UP indicator flashes.
Press L RETURN	Prints selections and current status.
Press L = A RETURN	Auto-linefeed off (Sends carriage return only.)
Press L = B RETURN	Auto-linefeed on (Sends carriage return and linefeed.)
Exit SET-UP.	SET-UP indicator stops flashing.

### Keyboard Layout

Use this feature only when a foreign character set keyboard option is installed. When you use a foreign character keyboard, set this feature to match the installed keyboard. (See the Installation Guide for more detail.)

Perform the following procedure to change the keyboard layout selection.

NOTE: Perform this procedure before installing keycaps.

Procedure	Indication/Comment
Enter SET-UP.	SET-UP indicator flashes.
Press:	To select:
K RETURN	Prints available character sets and current selection.
K = A RETURN	United States (ASCII)
K = B RETURN	United Kingdom
K = C RETURN	French Canadian
K = D RETURN	German
K = E RETURN	Swedish
K = F RETURN	French
K = G RETURN	Finnish
K = H RETURN	Norwegian/Danish
Exit SET-UP.	SET-UP indicator stops flashing.

#### SELF-TEST

The Letterwriter 100 has five printer self-test features. You can perform any of the tests to determine if there is a problem with the terminal. The self-tests provide a visual indication that the terminal is operating properly. The procedure to perform the self-tests is in Chapter 4.

#### FEATURE MEMORIES

The Letterwriter 100 features are contained in three memories as shown in Figure 3-8. There is an operating memory and two permanent memories. The following paragraphs describe the feature memories.

##### Operating Memory

The terminal operates according to the features entered in the operating memory. You can change a feature in operating memory by entering SET-UP and changing the feature. The computer can also change some of the features in operating memory. The features in operating memory that you and the computer can change are as follows.

Horizontal pitch	Vertical Tabs
Horizontal margins	End of line control
Horizontal tabs	Printer character sets
Vertical pitch	Alternate keypad
Form length	Printer new line
Vertical Margins	Answerback

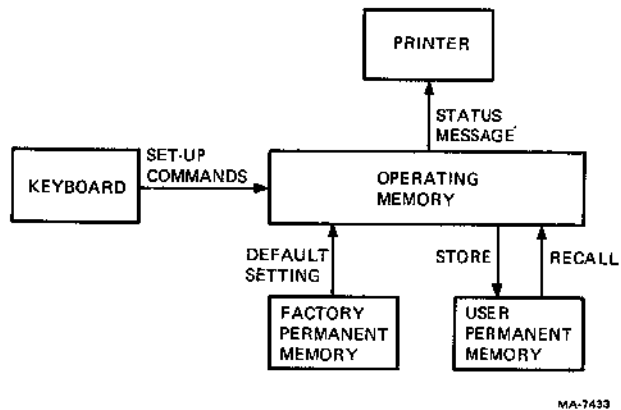

MA-7433

Figure 3-8 Feature Memories

The features in operating memory are replaced with the features in user permanent memory when power is turned on or a recall is performed. If power to the terminal is turned on and the features stored in user permanent memory are invalid or a reset is performed, the features in operating memory are replaced with the features in default memory.

**Status Message** -- To check the features stored in operating memory, print a status message. The status message lists the selected terminal features. A status message example is shown in Figure 3-9.

Perform the following procedure to print the status message.

Procedure	Indication/Comment
Enter SET-UP.	SET-UP indicator flashes.
Press * 8	Prints status message.
Exit SET-UP.	SET-UP indicator stops flashing.

#### **User Permanent Memory**

User permanent memory stores operator-selected features. The computer cannot change the features stored in user permanent memory. You can change the features in user permanent memory by changing the feature and performing a store while in SET-UP. You can enter the features from user permanent memory into operating memory by performing a recall. When power to the terminal is turned on, the features in user permanent memory are entered automatically into the operating memory.

NOTE: Retaining information in the permanent memories requires no power or batteries.

The following paragraphs describe the store and recall procedures.

**Store** -- enters the operating memory features into user permanent memory. Storing features can be performed from the keyboard only. The computer cannot store features.



LA24 version X5.4 14-October-81 KSR  
0.4K Buffer  
DPSs: 006...001003...

\*\*\*Keyboard Settings :

E-Local echo:Disabled  
K-Keyboard:United States  
L-Return key:<CR>  
Q-Keyclick:Disabled  
U-Break Key:Enabled  
Y-Keypad mode:numeric

\*\*\*Printer Settings :

B-Fitch Mode:Font Pitch  
C-G0 Character set:b  
D-G1 Character set:United States  
  G2 Character set:United States  
  G3 Character set:United States  
F-Form Length:264  
H-Horiz pitch (cpi):10  
J-End of line control:wrap mode  
V-Vert pitch (lpi):6  
W-NewLine request char.:none

\*\*\*Communication Settings :

A-Auto-answerback:Disabled  
N-Disconnect on EOT:Disabled  
O-Paper fault processing:XOFF (if enabled)  
P-Parity:7/S  
R-Receiver error:Print error block  
S-Speed(bps):9600  
X-Auto XON/XOFF:Enabled  
Z-Modem Control:No Modem Control-Restraint Mode

MA-8308

Figure 3-9 Sample Status Message

Perform the following procedure to store the features into user permanent memory.

Procedure	Indication/Comment
Enter SET-UP.	SET-UP indicator flashes.
While pressing SHIFT, press ( 9	Stores features in operating memory in user permanent memory. SET-UP indicator stays on for approximately 9 seconds. When SET-UP indicator starts to flash again, store is complete.
Exit SET-UP.	SET-UP indicator stops flashing.

Recall -- enters the features stored in user permanent memory into operating memory. All features previously stored in operating memory are erased.

Perform the following procedure to recall the features stored in user permanent memory.

Procedure	Indication/Comment
Enter SET-UP.	SET-UP indicator flashes.
Press ( 9	Enters features in user permanent memory into operating memory. SET-UP indicator stays on for approximately 1 second.
Exit SET-UP.	SET-UP indicator stops flashing.

#### Default Memory

Default memory, another permanent memory, contains the default settings. This memory holds typical selections for each SET-UP feature. The features stored in the default memory cannot be changed by you or the computer. If no SET-UP information is stored in the user permanent memory when power is turned on, the default settings are entered automatically into the operating memory.

NOTE: Retaining information in the permanent memories requires no power or batteries.

Table 3-4 lists the default values for the terminal.

Perform the following procedure to recall the SET-UP features default settings.

Procedure	Indication/Comment
Enter SET-UP.	SET-UP indicator flashes.
Press I RETURN	Enters terminal default settings into operating memory.
Exit SET-UP.	SET-UP indicator stops flashing.

Table 3-4 Feature Default Values

Feature	Default Value
Last character view	Automatic last character view
Keyclick	Off
Horizontal pitch	10 characters per inch
Left margin	Column 1 (First printable column)
Right margin	Column 132
Horizontal tabs	One tab stop every 8 columns
Vertical pitch	6 lines per inch
Form length	11 inches
Top margin	At 0 inch
Bottom margin	At 11th inch
Vertical tab stops	Tab stops set every line
Parity and data bits	Space parity/7 data bits
Receiver error processing	Check for receiver error (print substitute character)
Baud rate	1200 baud
Modem control	No modem control/restraint mode
Paper fault	No action
Coded Disconnect	Off
Local echo	Off
Auto-XON/XOFF	On
Answerback	None
Auto-answerback	Off
End of line control	On
Printer new line	No new line
Printer character sets	U.S. ASCII
BREAK key	On
Alternate keypad	Numeric
Auto-linefeed	Off
Keyboard layout	U.S. ASCII



CHAPTER 4  
MAINTENANCE AND TROUBLESHOOTING

**GENERAL**

This chapter includes the Letterwriter 100 maintenance procedures, a troubleshooting checklist, and a description of the terminal self-tests. The Maintenance section describes procedures to keep the terminal in good operating condition. The Troubleshooting Checklist describes a series of checks to make before requesting service. The Self-Test section describes the power-up self-test and the printer self-tests.

This chapter also includes installation, warranty, and service information.

**MAINTENANCE**

The Letterwriter 100 does not require you to perform preventive maintenance. Its surfaces and platen can be cleaned with a damp cloth only. Do not use cleaners with solvents or excessive amounts of water. Rubbing the keycaps with a dry or barely moist cloth is enough to clean them.

CAUTION: Do not attempt to remove the keycaps to clean them more thoroughly. You can damage the switch contacts if you replace the keycaps incorrectly.

Perform the following procedure to clean the platen.

1. Open the access cover.
2. Press the cover retainer clips and remove the cover (Figure 4-1).
3. Lift the bail bar.
4. Press the platen release levers and lift the platen straight up (Figure 4-2).
5. Clean the platen with a damp cloth.
6. Replace the platen in its original position. (Platen clicks into place when properly seated.) Make sure the platen rolls freely.

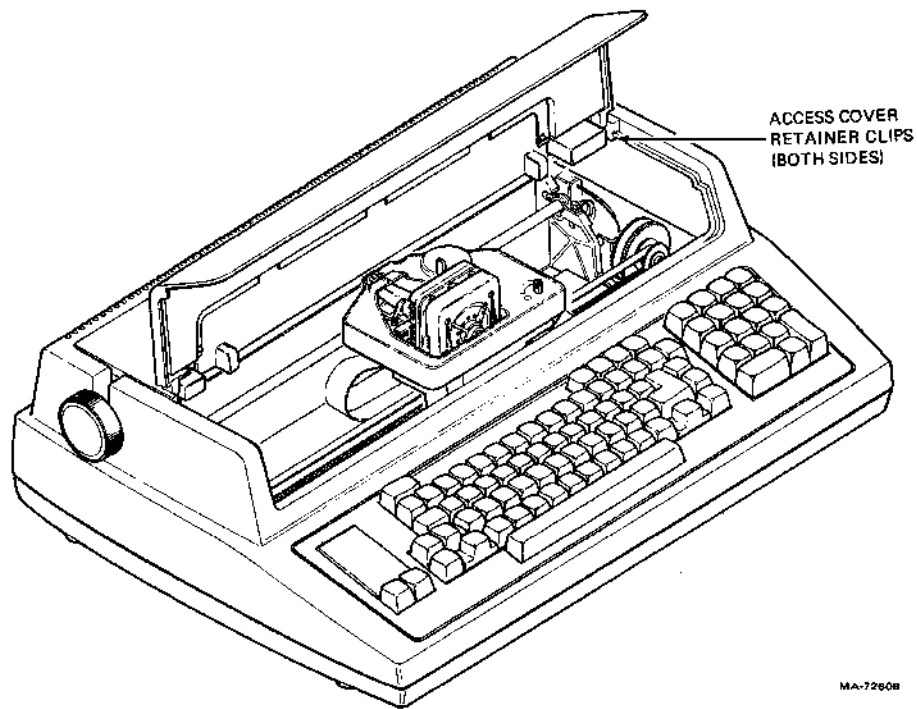

MA-72608

Figure 4-1 Access Cover Removal

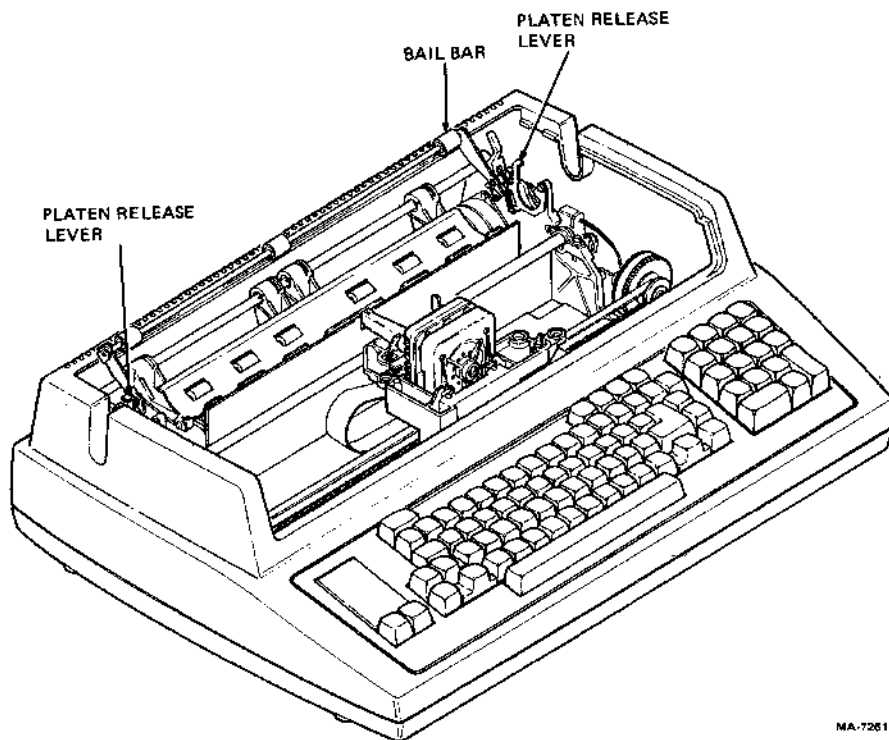

MA-7261B

Figure 4-2 Platen Removal

7. Lower the bail bar to its original position.
8. Reinstall the access cover.

The Letterwriter 100 covers are not meant to be weatherproof. There are several openings in the covers that liquids, coins, paper clips, and other objects can fall through. Such objects disturb the electronic operation of the printer if they come into contact with the circuitry. Therefore, do not place drinks and metal objects on any part of the terminal.

Keep the ventilation slots on the top and bottom of the terminal clear of obstruction. The terminal overheats if you block these slots.

#### TROUBLESHOOTING CHECKLIST

If you are unable to turn on power to the terminal or the terminal appears to be faulty, refer to Table 4-1. This table describes checks you should make before requesting service.

**Table 4-1 Troubleshooting Checklist**

Indication	Possible Cause	Action
Terminal will not turn on when power ON/OFF switch is set to on.	AC power cord is not plugged into wall receptacle or printer.	Plug in cord.
	Power is not coming from wall receptacle.	Check receptacle with a known working electrical device (such as a lamp). If no power, call your electrician.
	AC line fuse blown	Turn printer off and have fuse replaced. Refer to Figure 4-3 for fuse location.

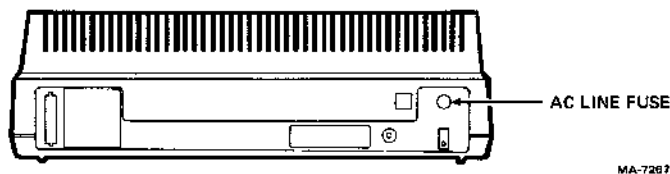

**Figure 4-3 AC Line Fuse Location**

**Table 4-1 Troubleshooting Checklist (Cont)**

Indication	Possible Cause	Action
Characters do not print; POWER/FAULT indicator flashes.	Terminal out of paper	Install paper and press <b>CLEAR FAULT</b> key to reset. Refer to Chapter 2 for paper loading information.
	Access cover open	Close access cover and press <b>CLEAR FAULT</b> key.
Characters do not print; carriage moves.	Printhead too far from paper	Readjust printhead. Refer to Chapter 2.
Characters do not print or are garbled.	Data set (modem) unplugged	Plug in data set.
	Incorrect communication setup	Make sure data communication features are set to match computer. Refer to Chapter 3.
Light print	Printhead too far from paper	Readjust printhead. Refer to Chapter 2.
	Ribbon out of ink	Replace ribbon cartridge. Refer to Chapter 2.
Ink smudges during printing.	Paper not firmly wrapped around platen	Lift bail bar and smooth paper over surface of platen. Lower bail bar to original position.
	Printhead too close to paper	Readjust printhead. Refer to Chapter 2.
Paper does not advance.	Paper not loaded properly	Reload paper. Refer to Chapter 2.
	Paper release lever incorrectly set (roll paper only)	Press paper release lever toward back of printer.
	Feed holes torn	Reload paper. Refer to Chapter 2.



**Table 4-1 Troubleshooting Checklist (Cont)**

<b>Indication</b>	<b>Possible Cause</b>	<b>Action</b>
Multipart paper tears	Printhead too close to paper	Readjust printhead. Refer to Chapter 2.
	Paper not straight in printer	Realign paper stack within 1 cm (1/2 in) of tractors.
	Tractors incorrectly adjusted	Readjust right tractor.
	Paper or printhead jam	Open access cover and clear jam. Close access cover and press CLEAR FAULT key.
Garbled or double characters	Incorrect communication setup	Make sure data communication features are set to match computer. Refer to Chapter 3.

#### **SELF-TESTS**

The Letterwriter 100 can perform a power-up self-test and several printer self-tests.

The following paragraphs describe the Letterwriter 100 self-tests.

#### **Power-Up Self-Test**

The Letterwriter 100 performs a power-up self-test whenever power to the terminal is turned on. Any errors during this self-test are displayed by the keyboard indicators. Refer to Table 4-2 for the power-up self-test indications.

#### **Printer Self-Tests**

The printer self-tests provide a visual indication that the printer is working properly. You can perform any of the following printer self-tests to determine if a problem exists.

- Character pattern
- Single character
- Horizontal registration
- Nonprinting
- Loopback

**Table 4-2 Power-Up Self-Test Indications**

DSR Indicator	POWER/FAULT Indicator	Probable Cause	Action
Off	Off, no carriage motion	Power supply	Refer to Table 4-1.
Off	Off, carriage motion	Defective indicators	Request service.
1 flash	1 flash	Defective font ROM 1	Replace ROM.
2 flashes	2 flashes	Defective font ROM 2 (may be cartridge or plug-in ROM)	Replace ROM.
3 flashes	3 flashes	Defective font ROM 3	Replace ROM.
4 flashes	4 flashes	Defective font ROM 4 (may be cartridge or plug-in ROM)	Replace ROM.
5 flashes	5 flashes	Defective font ROM 5	Replace ROM.
6 flashes	6 flashes	Defective first microcode ROM	Request service.
7 flashes	7 flashes	Defective second microcode ROM	Request service.
8 flashes	8 flashes	Defective RAM	Request service.
9 flashes	9 flashes	Defective optional RAM	Request service.
On or off	Flashing, no bell	Cover open or paper fault	Close cover. Press CLEAR FAULT key.
On or off	Flashing, bell tones	Head jam	Clear jam. Press CLEAR FAULT key.

Table 4-2 Power-Up Self-Test Indications (Cont)

DSR Indicator	POWER/FAULT Indicator	Probable Cause	Action
On	On	On-line/ready to receive data	
Off	On	Terminal is in modem mode with no DSR signal, or SELF-TEST key was pressed before power-up.	Release SELF-TEST key.

Figure 4-4 shows examples of the character pattern, single character, and horizontal registration self-test patterns. During the character pattern self-test, 94 characters are printed continuously within the selected margins. The single character self-test prints the selected character continuously within the selected margins. The horizontal registration self-test prints an asterisk in several passes. The nonprinting self-test causes the carriage to move from the left margin to the right margin, back to the left margin, and then advance one line. This test repeats until you stop the test.

Two loopback self-tests also can be performed. During the first loopback self-test, the transmit and receive lines of the terminal connect to each other. The terminal transmits a set of characters on its transmit lines and receives the characters on its receive lines. All control signals are checked, as are the baud rate and parity. The terminal compares the output and input and then prints one of the following messages.

```
Control line OK
Control line failed (20 mA?, jumpers?)
Data path OK
Data path failed
Data path stopped
```

NOTE: When using the 20 mA interface, the terminal prints the Control line failed (20 mA?, jumpers?) message when the first loopback test is completed successfully. The 20mA interface does not use control lines.

Use the second loopback test when the terminal fails the data path section of the first loopback test. The terminal transmits and prints the 94 printable characters at the selected speed and parity, allowing you to see the type of error.

If the terminal fails the control test (except 20 mA) or the data test, request service.

\$%&'()\*+,-./0123456789:;<=>?@ABCDEFGHIJKLMN0PQRSTUVWXYZ[\]^\_`abcede  
%&'()\*+,-./0123456789:;<=>?@ABCDEFGHIJKLMN0PQRSTUVWXYZ[\]^\_`ahcdef  
&'()\*+,-./0123456789:;<=>?@ABCDEFGHIJKLMN0PQRSTUVWXYZ[\]^\_`abcdefg  
'()\*+,-./0123456789:;<=>?@ABCDEFGHIJKLMN0PQRSTUVWXYZ[\]^\_`abcdefgh  
()\*+,-./0123456789:;<=>?@ABCDEFGHIJKLMN0PQRSTUVWXYZ[\]^\_`abcdefghi

FF  
FF  
FF  
FF  
FF

\*\*\*\*\*  
\*\*\*\*\*  
\*\*\*\*\*  
\*\*\*\*\*  
\*\*\*\*\*

MA-8324

Figure 4-4 Self-Test Examples

Testing is done with the aid of a loopback connector. EIA and 20 mA connectors are available from the Accessories and Supplies Group or can be manufactured locally (Figure 4-5). Refer to Chapter 5 for ordering information.

Perform the following procedures to operate the self-tests.

**Character Pattern** -- Use this procedure to operate the character pattern self-test.

Procedure	Indication/Comment
Press and hold CTRL down. Then press SET-UP and release both keys.	SET-UP indicator flashes.
Press T and then press RETURN	Prints character pattern self-test continuously until you end test.
Press SET-UP to end test and exit SET-UP.	SET-UP indicator stops flashing.

**Single Character** -- Use this procedure to operate the single character self-test.

Procedure	Indication/Comment
Press and hold CTRL down. Then press SET-UP and release both keys.	SET-UP indicator flashes.
Press T and then press any character key.	Prints selected character continuously until you end test.
Press SET-UP to end test and exit SET-UP.	SET-UP indicator stops flashing.

**Vertical Bar** -- Use this procedure to operate the vertical bar self-test.

Procedure	Indication/Comment
Press and hold CTRL down. Then press SET-UP and release both keys.	SET-UP indicator flashes.
Press T and then, while pressing SHIFT press \	Prints vertical bar self-test until you end test.
Press SET-UP to end test and exit SET-UP.	SET-UP indicator stops flashing.

CONNECTORS

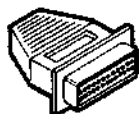

FROM PIN	TO PIN	TO PIN
2	3	
4	5	
20	6	
19	22	
12	23	8

EIA

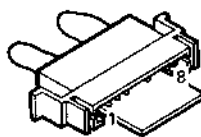

FROM PIN	TO PIN
2	3
5	7

20 MA

MA-7266A

Figure 4-5 Loopback Connectors

**Nonprinting --** Use this procedure to operate the nonprinting self-test.

<b>Procedure</b>	<b>Indication/Comment</b>
Press and hold CTRL down. Then press SET-UP and release both keys.	SET-UP indicator flashes.
Press T and then press SPACE bar.	Starts nonprinting self-test.
Press SET-UP to end test and exit SET-UP.	SET-UP indicator stops flashing.

**Loopback --** Use this procedure to operate the loopback self-tests.

<b>Procedure</b>	<b>Indication/Comment</b>
If 20 mA interface option is used, set one TRANS/REC switch to NORMAL and one to ACTIVE. (Refer to Option Installation Guide for procedure to reach switch.)	
Connect loopback connector to terminal interface.	
Press and hold CTRL down. Then press SET-UP and release both keys.	SET-UP indicator flashes.
Press T and then press \	Starts loopback test 1. Terminal prints a pass or fail message.
Press T and then, while pressing SHIFT, press /	Starts loopback test 2. Terminal prints a pass or fail message.

Procedure	Indication/Comment
Press SET-UP to exit SET-UP.	SET-UP indicator stops flashing.

Remove loopback connector from terminal interface.

If 20 mA interface option is used, return TRANS/REC switches to original positions. (Refer to Option Installation Guide for procedure to reach switch.)

#### INSTALLATION/WARRANTY

For customers who have purchased directly from DIGITAL, reference the sales agreement for installation and warranty terms purchased with this terminal.

For customers who have purchased, leased, or rented from a vendor other than DIGITAL, contact your vendor for information regarding installation and warranty terms purchased with this terminal.

#### DIGITAL SERVICES

DIGITAL provides a wide range of maintenance and customer services for your terminal. Using these services, you can design a plan to meet your service needs, from complete DIGITAL maintenance to complete self-maintenance. Vendors supplying DIGITAL products may use these services as factory backup support.

#### On-Site Service

DIGITAL offers responsive, low-cost, factory-level maintenance performed at your site by trained Terminals Service Specialists. This maintenance is provided through service agreements or per-call service.

- Service Agreements cover all your maintenance needs, including priority response; labor, materials, and travel for a fixed monthly charge.
- Per-call service is provided on a "time" and "materials" basis and can serve as a backup to your own in-house maintenance programs.



### **Off-Site Service**

For customers who have troubleshooting expertise, but need assistance for the component repair, DIGITAL has a worldwide network of Product Repair Centers (PRCs) and the Customer Returns Area (CRA). Through a wide array of service product offerings this logistics network offers cost-effective services that include the following features.

- Module Mailer
- Fixed price exchange
- Product refurbishment

### **Spare Parts**

In further effort to assist customers who choose to perform their own computer maintenance, DIGITAL's Customer Spares organization provides thorough and timely spares support through the following features.

- Spares inventory planning
- Component/subassembly spares
- Maintenance test equipment
- Maintenance documentation service
- Emergency spare parts

### **Training**

DIGITAL's Education Services group offers hardware maintenance courses at any of our 17 worldwide training centers; or, depending on your specific training requirements, courses can be provided in your own facilities.



CHAPTER 5  
ACCESSORIES AND SUPPLIES

**GENERAL**

The Letterwriter 100 offers improved printing quality and forms handling. A wide variety of accessories and supplies are available to enhance printer versatility and make operation easier. The following lists describe the Letterwriter 100 accessories and supplies and the correct ordering information.

**SUPPLIES**

Item Number	Part Number	Description
<b>Ribbon</b>		
1	LA10R-03	Letterwriter 100 cartridge, 3/box
1	LA10R-12	Letterwriter 100 cartridge, 12/box
1	LA10R-A4	Letterwriter 100 cartridge, 12 dozen
1	LA10R-H2	Letterwriter 100 cartridge, 60 dozen
<b>Paper</b>		
2	H9850-PA	14-7/8 in X 11 in, 1/2 inch green and white bar, 18 lb, 1 part
2	H9850-PB	14-7/8 in X 11 in, 1/2 inch green and white bar, 15 lb, 2 part, carbon
2	H9850-PC	14-7/8 in X 11 in, 1/2 inch green and white bar, 15 lb, 4 part, carbon
2	H9850-PD	14-7/8 in X 11 in, 1/2 inch green and white bar, 2 part, no carbon

Item Number	Part Number	Description
2	H9850-PE	14-7/8 in X 11 in, 1/2 inch green and white bar, 15 lb, 4 part, no carbon
2	H9850-PF	9-7/8 in X 11 in, 3 gray rules/in, 15 lb, 1 part
2	H9850-PH	9-1/2 in X 11 in, blank, 20 lb, 1 part, 1/2 inch perforated edges
2	H9850-PJ	9-1/2 in X 11 in, blank, 2 part, no carbon, 1/2 inch perforated edges
2	H9850-PK	9-1/2 in X 11 in, blank, 4 part, no carbon, 1/2 inch perforated edges
2	H9850-PL	8-1/2 in X 11 in, 1/2 inch green and white bar, 15 lb, 1 part
2	H9850-PM	12 in X 8-1/2 in, blank, 1 part
2	H9850-PN	9-7/8 in X 11 in, 3 gray rules/in, 2 part, carbon
2	H9850-PP	9-7/8 in X 11 in, 3 gray rules/in, 4 part, carbon
2	H9850-PR	9-1/2 in X 11 in, blank, 2 part, carbon, 1/2 inch perforated edges
2	H9850-PS	9-1/2 in X 11 in, blank, 4 part, carbon, 1/2 inch perforated edges
2	H9850-PT	8-1/2 in X 11 in, 1/2 inch green and white bar, 2 part, carbon
2	H9850-PU	8-1/2 in X 11 in, 1/2 inch green and white bar, 4 part, carbon
2	36-05365-01	Roll paper, 21.6 cm X 11.4 cm (8-1/2 in X 4-1/2 in), 12/box
2	36-16611-01	Roll paper, 36.8 cm X 7.6 cm, (14-1/2 in X 3 in) approx. 175 ft per roll, 10/box

## ACCESSORIES

Item Number	Part Number	Description
3	LAX34-ZA	Portable terminal carrying case (also room for cables, fanfold paper, and either an acoustic coupler/modem or LAX34-AL paper tractors), 9-1/4 in high X 24 in wide X 19 in deep
4	LAX34-AL	Fanfold paper tractors
5	LAX34-RL	Roll paper holder
6	LAX34-LL	Paper low detection option
7	LAX34-SL	Terminal stand
8	LAX34-SM	Terminal stand casters (set of two)
9	LAX34-SP	Wireform paper catch for LAX34-SL
10	LAX34-SQ	Wireform paper shelf for LAX34-SL
11	LAX34-SR	Table extension for LAX34-SL
12	LAX34-SU	Accessories kit for LAX34-SL
13	H981-A	Copy stand for LAX34-SL
14	LAX34-SW	Wireform paper tray for DECwriter IV and V terminals
15	LA10X-FL	Multiple font option
16	LA10X-AA	Courier-10 ROM cartridge
16	LA10X-AB	Courier-12 ROM cartridge
16	LA10X-AC	Gothic-12 ROM cartridge
16	LA10X-AD	Orator-10 ROM cartridge
16	LA10X-AE	Symbols ROM cartridge
16	LA10X-BA	Courier-10 foreign character set ROM cartridge
16	LA10X-BB	Courier-12 foreign character set ROM cartridge

Item Number	Part Number	Description
16	LA10X-BC	Gothic-12 foreign character set ROM cartridge
16	LA10X-BD	Orator-10 foreign character set ROM cartridge
17	LA10X-CA	Courier-10 plug-in ROM
17	LA10X-CB	Courier-12 plug-in ROM
17	LA10X-CC	Gothic-12 plug-In ROM
17	LA10X-CD	Orator-10 plug-in ROM
17	LA10X-CE	Symbols plug-in ROM
17	LA10X-DA	Courier-10 foreign character set plug-in ROM
17	LA10X-DB	Courier-12 foreign character set Plug-In ROM
17	LA10X-DC	Gothic-12 foreign character set plug-in ROM
17	LA10X-DD	Orator-10 foreign character set plug-in ROM
18	M9850-FA	Paper caddy with four 2 inch swivel casters for transporting printer paper, 15 3/4 in wide X 11 3/4 in deep
19	H9850-DA	Antistatic floor mat, DECmat, 1.22 m X 1.83 m (4 ft X 6 ft), Driftwood (brownish-gray)
19	H9850-DB	Antistatic floor mat, DECmat, 1.22 m X 1.83 m (4 ft X 6 ft), Summer Earth (brown/gold)
19	H9850-DC	Antistatic floor mat, DECmat, 0.91 m X 3.05 m (3 ft X 10 ft), Silver Birch (orange/brown)
19	H9850-DD	Antistatic floor mat, DECmat, 0.91 m X 3.05 m (3 ft X 10 ft), Autumn Bronze (orange/brown)
19	H9850-DE	Antistatic floor mat, DECmat, 0.91 X 3.05 m (3 ft X 10 ft), Driftwood (brownish-gray)

Item Number	Part Number	Description
19	H9850-DF	Antistatic floor mat, DECmat, 1.22 m X 1.83 m (4 ft X 6 ft), Silver Birch (silver-gray/brown)
19	H9850-DH	Antistatic floor mat, DECmat, 1.22 m X 1.83 m (4 ft X 6 ft), Autumn Bronze (orange/brown)
20	H9850-HA	Heavy gauge vinyl dust cover (roll paper holder option)
20	H9850-HB	Heavy gauge vinyl dust cover (tractor option)
21	DF01-A	Acoustic telephone coupler, 300 baud
22	LAX34-CL	20 mA interface option and cable
23	BC22A-10	EIA RS232 female-female shielded null modem cable, 3 m (10 ft)
23	BC22A-25	EIA RS232 female-female null modem cable, 7.6 m (25 ft)
23	BC23A-10	Kit of five BC22A-10
23	BC23A-25	Kit of five BC22A-25

NOTE: EIA RS232C specifies a maximum cable length of no more than 50 feet.

23	BC03M-A0	Female-female null modem cable, 30.5 m (100 ft)
23	BC03M-B5	Female-female null modem cable, 76.2 m (250 ft)
23	BC03M-E0	Female-female null modem cable, 152.4 m (500 ft)
23	BC03M-L0	Female-female null modem cable, 304.8 m (1000 ft)
23	BC22B-10	EIA RS232 male-female shielded extension cable, 3 m (10 ft)
23	BC22B-25	EIA RS232 male-female shielded extension cable, 7.6 m (25 ft)
23	BC23B-10	Kit of five BC22B-10

Item Number	Part Number	Description
23	BC23B-25	Kit of five BC22B-25
23	BC05X-15	20 mA current loop extension cable, 4.6 m (15 ft)
23	BC05X-25	20 mA current loop extension cable, 7.6 m (25 ft)
23	BC05X-50	20 mA current loop extension cable, 15.2 m (50 ft)
23	30-10958-02	DF01-A acoustic telephone coupler interface cable
24	H9850-AP	Media-mate shelf or file storage cart with casters and lockable drawer, 64.1 cm high X 38.1 cm deep X 47 cm wide (25-1/4 in X 15 in X 18-1/2 in)
25	H970-EB	Terminal table, 68.6 cm high X 91.4 cm wide X 76.2 cm deep (27 in X 36 in X 30 in) with levelers
26	H9532-AA	Work-station desk with blue front panel and gray side panels, levelers, 122 cm wide X 76.2 cm high X 76.2 cm deep (48 in X 30 in X 30 in)
26	H9532-AB	Work-station desk with brown front panel and brown side panels, levelers, 122 cm wide X 76.2 cm high X 76.2 cm deep (48 in X 30 in X 30 in)
27	LAX34-KL	Auxiliary keypad option (14 key)
28	LAX34-HL	APL character set keycaps option
28	LAX34-JL	International character set keycaps option
29	LA12X-UA	Blank keycap kit of 50, Row 4*
29	LA12X-UB	Blank keycap kit of 50, Row 1*
29	LA12X-UC	Blank keycap kit of 50, Row 2*

\* Row 1 is immediately above the space bar.



Item Number	Part Number	Description
29	LA12X-UD	Blank keycap kit of 50, F&J type
29	LA12X-UE	Blank keycap kit of 50, SET-UP
29	LA12X-UF	Blank keycap kit of 50, TAB
29	LA12X-UH	Blank keycap kit of 50, CAPS LOCK
29	LA12X-UJ	Blank keycap kit of 50, SHIFT
29	LA12X-UL	Main array blank keycap set
29	LA12X-UM	Blank keycap kit of 50, CR
29	LA12X-UN	Blank keycap kit of 50, ENTER
29	LA12X-UP	Blank keycap kit of 50, Number pad Ø
29	LA12X-UR	Blank keycap kit of 50, Row 3*
29	LA12X-US	Blank keycap kit of 50, Row 5*
29	LA12X-UT	Auxiliary keypad blank keycap set

#### LOOPBACK CONNECTORS

30	12-15336-01	EIA
30	70-18353	20 mA

#### DOCUMENTATION

31	EK-LW100-UG	Letterwriter 100 User Documentation Package:  Installation Guide Operator Guide Programmer Reference Manual Operator and Programmer Reference Card
31	EK-LW100-IN	Letterwriter 100 Installation Guide
31	EK-LW100-OP	Letterwriter 100 Operator Guide
31	EK-LA100-RM	LA100 Programmer Reference Manual
31	EK-LW100-RC	Letterwriter 100 Operator and Programmer Reference Card

\* Row 1 is immediately above the space bar.

Item Number	Part Number	Description
31	EK-LA100-PS	LA100 Series Pocket Service Guide
31	EK-LA100-TM	LA100 Series Technical Manual
31	EK-LA100-IP	LA100 Series Illustrated Parts Breakdown
32		LA100 Engineering Drawings

#### SPARES KITS

--                    4A-LA100-AA       Letterwriter 100 spares kit

#### ORDERING INFORMATION

##### Continental USA

Call 800-258-1710, or mail order to:

Digital Equipment Corporation  
P.O. Box CS2008  
Nashua, NH 03061

##### New Hampshire

Call 603-884-6660, or mail order to:

Digital Equipment Corporation  
P.O. Box CS2008  
Nashua, NH 03061

##### Alaska or Hawaii

Call 408-734-4915, or mail order to:

Digital Equipment Corporation  
632 Caribbean Drive  
Sunnyvale, CA 94086

##### Canada

Call 800-267-6146, or mail order to:

Digital Equipment of Canada LTD.  
P.O. Box 13000  
Kanata, Ontario, Canada K2K 2A6  
Att: A & SG Business Manager  
Telex: 610-562-8732

APPENDIX A  
LETTERWRITER 100 MODEL VARIATIONS

Table A-1 lists and describes the Letterwriter 100 model variations and the options included in each terminal.

**Table A-1 Letterwriter 100 Model Variations**

<b>Option Number</b>	<b>Description</b>
LA10X-AA	English-language model with Courier 10 and Orator 10 fonts
LA10X-BA	English-language model with Courier 10 and Orator 10 fonts, keypad, tractors, BC22A-10 cable, ribbon cartridge, and paper
LA10X-CA	English-language model with Courier 10 and Orator 10 fonts, multiple font option, keypad, tractors, BC22A-10 cable, ribbon cartridge, and paper
LA10X-AB	International model with Courier 10 English, international character sets, international character set keycaps
LA10X-BB	International model with (new) Courier 10 English, international character sets, international character set keycaps, keypad, tractors, BC22A-10 cable, ribbon cartridge, and paper
LA10X-CB	International model with Courier 10 English, international character sets, international character set keycaps, multiple font option, keypad, tractors, BC22A-10 cable, ribbon cartridge, and paper









