

# **TS11 Subsystem**

## **Pocket Service Guide**

**EK-OTS11-PS-005**

# **TS11 Subsystem**

## **Pocket Service Guide**

Prepared by Educational Services  
of  
Digital Equipment Corporation

1st Edition, June 1980  
2nd Edition, December 1980  
3rd Edition, August 1981  
4th Edition, January 1983  
5th Edition, January 1984

Copyright © 1980, 1981, 1983, 1984 by Digital Equipment Corporation.

All Rights Reserved.  
Printed in U.S.A.

The reproduction of this material, in part or whole, is strictly prohibited. For copy information, contact the Educational Services Department, Digital Equipment Corporation, Maynard, Massachusetts 01754.

The information in this document is subject to change without notice. Digital Equipment Corporation assumes no responsibility for any errors that may appear in this document.

This equipment generates, uses, and may emit radio frequency. The equipment has been type tested and found to comply with the limits for a Class A computing device pursuant to Subpart J of Part 15 of FCC rules, which are designed to provide reasonable protection against such radio frequency interference. Operation of this equipment in a residential area may cause interference in which case the user at his own expense will be required to take whatever measures may be required to correct the interference.

The following are trademarks of Digital Equipment Corporation, Maynard, Massachusetts.

<b>digital</b>	DECwriter	RSTS
DEC	DIBOL	RSX
DECSYSTEM-10	MASSBUS	UNIBUS
DECSYSTEM-20	PDP	VAX
DECUS	P/OS	VMS
DECmate	Professional	VT
DECnet	Rainbow	Work Processor

# CONTENTS

## 1 INTRODUCTION

1.1	General .....	1
1.2	Subsystem Overview .....	1
1.3	TS11 Assemblies .....	1
1.4	Controls and Indicators .....	6
1.4.1	Operator Panel (Normal Mode) .....	6
1.4.2	Operator Panel (Maintenance Mode) ...	7
1.4.3	Maintenance Panel (Test Panel) .....	8
1.5	Tools .....	10
1.6	Spares Kit List .....	10
1.7	Applicable Documentation .....	11
1.8	PDP-11 Based Diagnostics .....	12
1.9	VAX-Based Diagnostics .....	13

## 2 INSTALLATION

2.1	M7982 Installation .....	14
2.2	Installation Checklist .....	14

## 3 TROUBLESHOOTING

3.1	General .....	18
3.2	Internal Microdiagnostics .....	18
3.2.1	UTSTM .....	18
3.2.2	STAKM .....	18
3.2.3	IOTSM .....	18
3.2.4	CATSM .....	18
3.2.5	PETSM .....	19
3.3	Initialization Microdiagnostics .....	19
3.4	Off-Line Microdiagnostics .....	19
3.5	Error Codes .....	23
3.5.1	Fatal Errors .....	23
3.5.2	Nonfatal Errors .....	27
3.5.3	Off-Line Test Errors .....	30
3.6	How To Run Microdiagnostics .....	34
3.6.1	Internal Microdiagnostics (Inline) ....	34
3.6.2	Internal Microdiagnostics (Initialization) .....	34

3.6.3	Off-Line Microdiagnostics (Customer Confidence and Maintenance) .....	35
3.7	Customer Confidence Check .....	35
3.8	Operating PDP-11 Based Diagnostics ...	35
3.8.1	Data Reliability Program Tests .....	36
3.8.2	Control Logic Program Tests .....	36
3.8.3	Program Control Flags .....	37
3.8.4	Hardware Parameters .....	37
3.8.5	Software Parameters .....	37
3.9	Operating VAX-Based Diagnostics .....	38
3.9.1	Data Reliability Test Sections .....	38
3.9.2	Subsystem Repair Test Sections .....	38
3.9.3	Control Flags .....	38
3.10	Special Procedures .....	38
3.10.1	Dead Track Card Identifier .....	39

## 4 REMOVAL AND REPLACEMENT

4.1	Special Procedures .....	42
4.2	Module Replacement .....	42
4.3	Operator Panel .....	43
4.4	BOT/EOT Sensor .....	43
4.5	Capstan Wheel .....	43
4.5.1	Removal .....	43
4.5.2	Replacement .....	44
4.6	Fixed Reel Assembly .....	44
4.6.1	Removal .....	44
4.6.2	Replacement .....	44
4.7	Snap Lock Hub Assembly .....	44
4.7.1	Removal .....	45
4.7.2	Replacement .....	45
4.8	Lower Roller Assembly .....	45
4.8.1	Removal .....	45
4.8.2	Replacement .....	45
4.9	Upper Roller Assembly .....	46
4.10	Tension Arm Assembly .....	46
4.10.1	Removal .....	46
4.10.2	Replacement .....	47
4.11	AC Input/Line Filter Box .....	47

## 5 ADJUSTMENTS

5.1	Quick Reference Adjustment Specification .....	48
5.2	Adjustment Procedures .....	51
5.2.1	Tension .....	51
5.2.2	Final Tension Adjustment .....	52
5.2.3	Tape Path Alignment Adjustment ....	53

5.2.4	Tachometer Adjustment .....	55
5.2.5	Speed Test .....	55
5.2.6	Preamplifier Amplitude Adjustment ....	56
5.2.7	Threshold Adjustment .....	58
5.2.8	VCO Adjustment .....	59
5.2.9	Skew Meter Calibration .....	60
5.2.10	Head Skew Adjustment .....	60
5.2.11	Tension Arm Transducer Coarse Adjustment .....	60
5.2.12	Tension Arm Transducer Fine Adjustment .....	61

## APPENDIX A REGISTER SUMMARY

## APPENDIX B TROUBLESHOOTING FLOWCHART

### FIGURES

1-1	TS11 Subsystem Block Diagram .....	2
1-2	TS11 Subsystem Major Assemblies .....	3
1-3	Logic Rack (Rear View) .....	3
1-4	Transport Assemblies (Rear View) .....	4
1-5	Transport Assemblies (Front View) .....	5
1-6	Operator Panel (Maintenance Mode) ....	6
1-7	Maintenance Panel (Front View) .....	8
2-1	M7982 Interface Module .....	16
2-2	Typical Subsystem Configuration .....	17
2-3	TS11 Signal Cabling.....	17
4-1	Deck Plate Assembly (Rear View) .....	46
5-1	Tension Arm Adjustment .....	52
5-2	Capstan Gimbal Adjustment .....	53
5-3	Tape Path Guides .....	54
5-4	Capstan Speed Adjustment .....	56
5-5	Read Preamp Locator .....	57
5-6	Read Preamp Adjustment .....	58
5-7	Threshold and VCO Adjustment .....	59
5-8	Head Skew Adjustment .....	61
A-1	TS11 Register Summary .....	63
A-2	Bus Address Register .....	64
A-3	Data Buffer Register .....	64
A-4	STATUS Register .....	65
A-5	Residual Frame Count Register .....	65
A-6	Extended STATUS Register 0 .....	66
A-7	Extended STATUS Register 1 .....	66
A-8	Extended STATUS Register 2 .....	67
A-9	Extended STATUS Register 3 .....	67
B-1	Troubleshooting Flowchart .....	69

## TABLES

2-1	Interrupt Vector and Address Assignments .....	14
2-2	Address and Vector Examples .....	15
3-1	Test Descriptions .....	19
3-2	Fatal Microprocessor Errors .....	24
3-3	Nonfatal Microprocessor Errors .....	27
3-4	Customer Confidence or Maintenance Mode Test Errors .....	30
3-5	Bring-Up Procedure Errors .....	40
3-6	Dead Track/Module Locations .....	41
4-1	Module and Adjustment Number .....	43
4-2	120 V/240 V AC Input Part Numbers .....	47
5-1	Adjustment Specifications .....	48

# **1 INTRODUCTION**

## **1.1 GENERAL**

This pocket service guide is for technicians trained to service a TS11 Subsystem. Procedures are brief, concise, and support the maintenance philosophy of module replacement.

The first two chapters present product overview and installation information for quick review. Chapter 3 provides troubleshooting information. Diagnostics and maintenance panel features allow quick location of malfunctions. Chapter 4 describes removal and replacement procedures, and Chapter 5 explains how to check and adjust the TS11.

Programming information is not provided, but register summaries and definitions are found in Appendix A and a Troubleshooting Flowchart in Appendix B.

This chapter is a compilation of information and reference material needed to service the TS11 subsystem. It provides a quick overview of the product.

## **1.2 SUBSYSTEM OVERVIEW**

Figure 1-1 shows the TS11 subsystem block diagram.

## **1.3 TS11 ASSEMBLIES**

Figures 1-2 through 1-6 show the major TS11 assemblies.



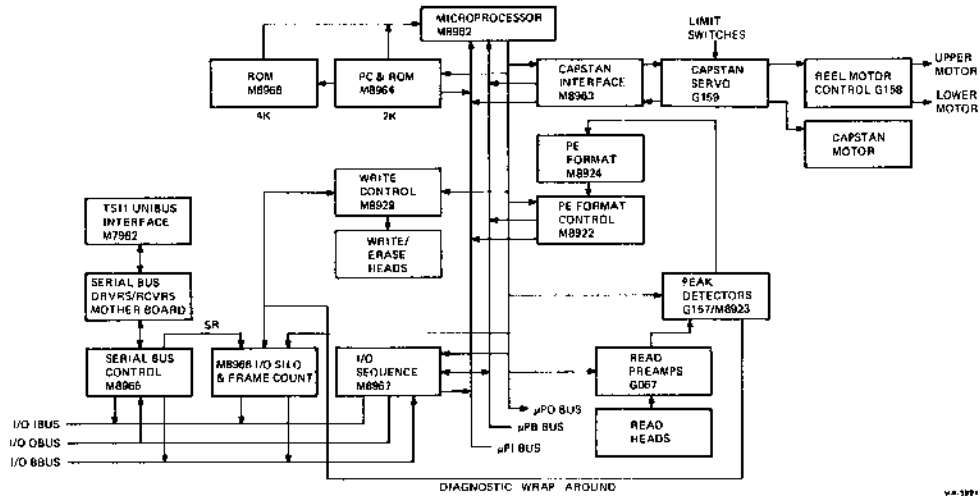
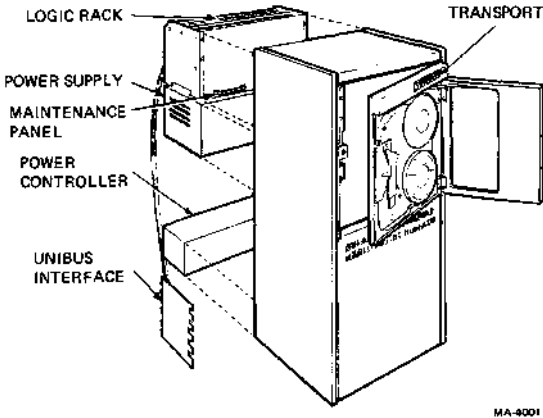
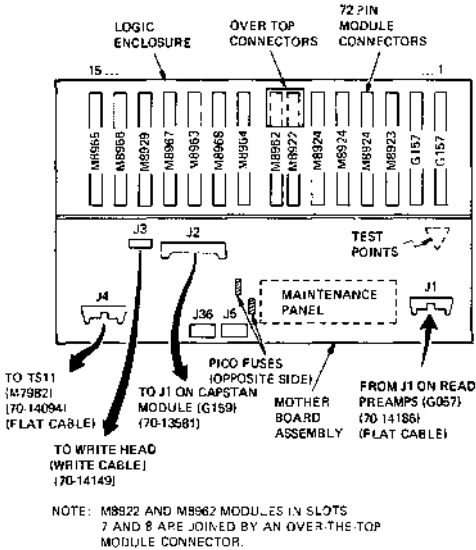

Figure 1-1 TS11 Subsystem Block Diagram



MA-4001

Figure 1-2 TS11 Subsystem Major Assemblies



MA-4002

Figure 1-3 Logic Rack (Rear View)

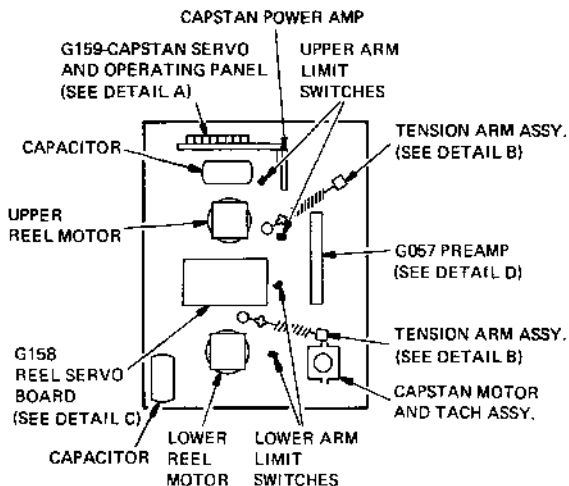

DETAIL A

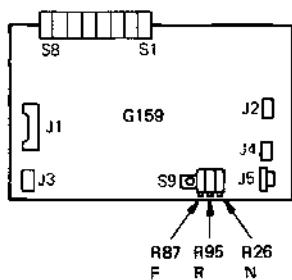

DETAIL B

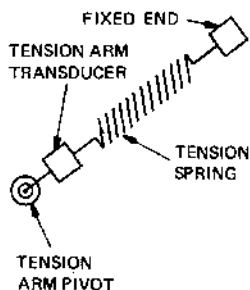

DETAIL C

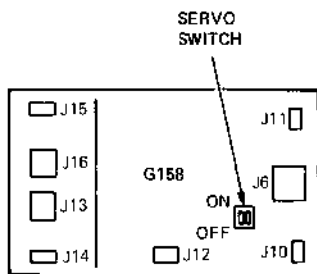

DETAIL D

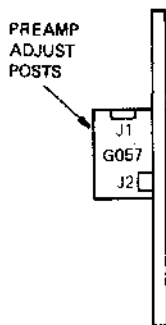

MA-4007

Figure 1-4 Transport Assemblies - Rear View

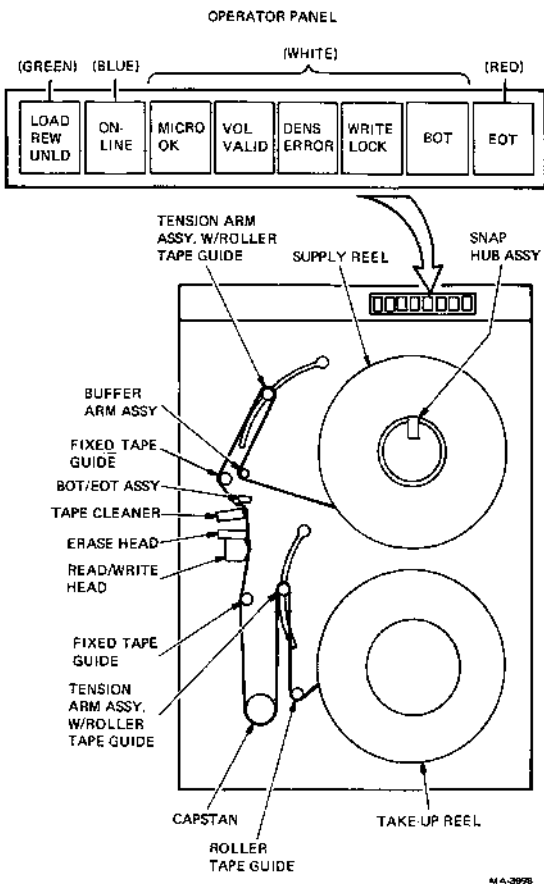
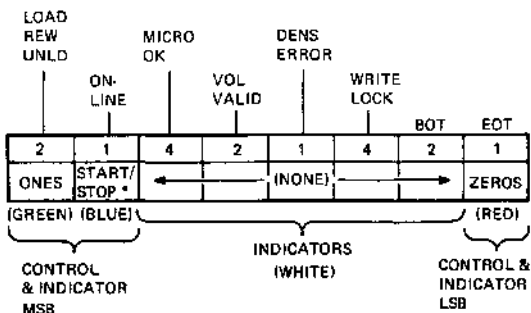

Figure 1-5 Transport Assemblies (Front View)

INDICATOR FUNCTIONSWITCH FUNCTION

\* = ALSO LOADS TAPE  
IF NOT LOADED  
(IF ALL DISPLAY  
LIGHTS ARE OUT)

MA-4000

Figure 1-6 Operator Panel (Maintenance Mode)

**1.4 CONTROLS AND INDICATORS**

The following section offers a brief explanation of TS11 subsystem controls and indicators.

**1.4.1 Operator Panel (Normal Mode)**

Refer to Figure 1-3 while reading the following text.

<b>Control</b>	<b>Function</b>
LOAD REW UNLD	Used to load, unload, or rewind tape.

**NOTE**

**Tape will not rewind if M7982 is not powered up.**

ON-LINE	Used to place unit on-line or off-line.
---------	--

<b>Indicator</b>	<b>Function</b>
LOAD REW UNLD	Tape loaded and reel motors energized when on.

<b>Indicator</b>	<b>Functions</b>
ON-LINE	TS11 ready for system commands when on.
MICRO OK (microprocessor okay)	Correct microprocessor operation when on.
VOL VALID	Tape reel status change occurred when on.
DENS ERROR	Incorrect tape density being read when on.
WRITE LOCK (write locked)	No reel mounted or no write-ring in mounted reel when on.
BOT (beginning of tape)	BOT marker is over sensor when on.
EOT (end of tape)	EOT marker is over or passed sensor when on.

#### **1.4.2 Operator Panel (Maintenance Mode)**

Refer to Figure 1-6 while reading the following text.

<b>Control</b>	<b>Function</b>
ONES LOAD REW UNLD	Enters one into LSB position and shifts entire register contents left when pressed.
START/STOP ON-LINE	Loads tape if not loaded and causes selected test to run when pressed and halt when released.
ZEROS (EOT)	Enters zero into LSB position and shifts entire register contents left when pressed.

#### **Indicator Functions**

All indicators display in octal notation (377 maximum) the number of the test entered by means of the ones and zeros controls. A test failure displays an error code.

### 1.4.3 Maintenance Panel (Test Panel)

Refer to Figure 1-7 while reading the following text.

Test Points	Function
RD0-RD7; RDP	Read channel analog test points; these signals are preamplifier outputs for data and parity channels.
SKEW OUT	Analog output of internal skew meter; signal is overall skew as function of voltage.

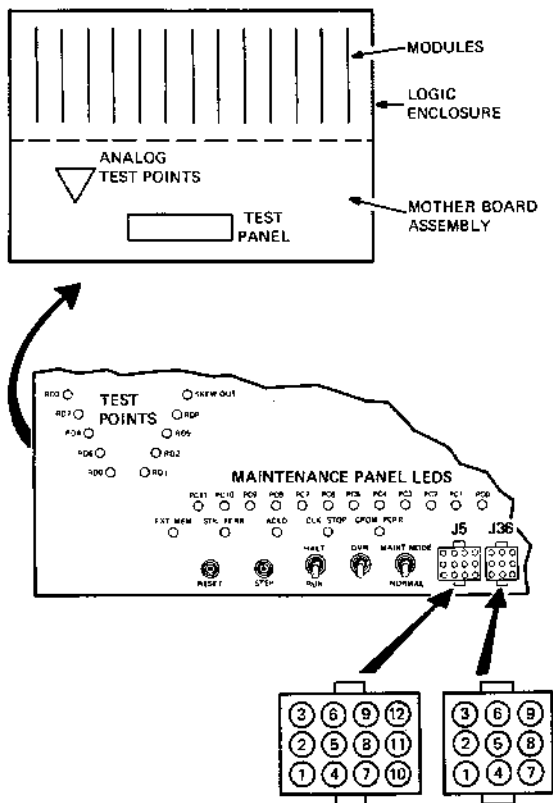

MA-4006

Figure 1-7 Maintenance Panel (Front View)

<b>Indicators</b>	<b>Function</b>
PC11-PC0	Displays contents of microprocessor program counter, PC0 is LSB.
EXT MEM	Indicates which of two 2K memory banks is accessed when PC displays an address larger than 3777(8); i.e., 0-3777 always accesses same ROMs on M8964 but 4000-7777 access one of two banks of ROMs on M8968 depending on state of EXT MEM bit.
STK PERR	Indicates stack parity error has occurred when on.
AC LO	Indicates ac line voltage went below acceptable limits when on.
CLK STOP	Indicates microprocessor clock not running when on.
CROM PERR	Indicates control ROM parity error occurred when on.

<b>Controls</b>	<b>Function</b>
RESET	Resets microprocessor to PC=0 for a reinit and clears registers when pressed.
STEP	Causes halted microprocessor to do one instruction when pressed.
HALT/RUN	Disables or enables microprocessor.



<b>Controls</b>	<b>Function</b>
OVR (override)	Overrides or enables halt-on-error function.
MAINT MODE/ NORMAL	Places transport into maintenance or normal.

### 1.5 TOOLS

In addition to the standard Digital tool kit you need the following tools to service the TSI 1.

<b>Description</b>	<b>Digital PN</b>
Oscilloscope with probes (2-X10)	-
<i>Special test tape</i>	29-11696
Master skew tape (600 ft)	29-22020
(1200 ft)	29-19224
BOT/EOT markers	90-09177
Hub spanner wrench	29-22999
Double height extender	W984
1-3/8 in. socket (3/4 in. drive)	-
Tension gauge (0 g to 500 g)	29-20664
Hub height gauge	96-07951
Torque screwdriver	29-13212
Phillips bit 2	29-11772

## 1.6 SPARES KIT LIST

The spares kit includes the following parts.

<b>Description</b>	<b>Digital PN</b>
Preamplifier module	G057
Read/write module	G157
Reel servo module	G158
Capstan servo module	G159
UNIBUS interface	M7982
PE control	M8922
Read control	M8923
PE format	M8924
Write control	M8929
Microprocessor	M8962
Stack	M8963
ROM board	M8964
I/O shift register	M8965
I/O silo	M8966
I/O control	M8967
ROM extension	M8968
Pico fuses 5A	12-05747
Switch, toggle	12-09590
Switch, pushbutton	12-11079
EOT/BOT assembly	70-16662
Bulbs (GE #73)	12-12716-01
Snap lock hub assembly	12-13119
Fixed roller assembly	70-15475
CD kit case	29-23083
Capstan driver board extender	54-13692
Tension arm	70-14014
Limit switch	70-15666
Capstan wheel	74-18010
Capstan wheel clamp	74-18021
Lens caps	

### **Color Logo**

Green	LOAD REW UNLD	12-14343-30
Blue	ON-LINE	12-14343-31
White	MICRO OK	12-14343-32

**Color Logo**

White	VOL VALID	12-14343-33
White	DENS ERROR	12-14343-34
White	WRITE LOCK	12-14343-35
White	BOT	12-14343-36
Red	EOT	12-14343-37

**1.7 RELATED DOCUMENTATION**

The following documentation is available on the TS11 subsystem.

TS11-A Print Set	MP00849
TS11 Subsystem Technical Manual (User Guide plus theory of operation and servicing)	EK-OTS11-TM
TS11 Subsystem User Guide (installation, microdiagnostic operation, customer care and operating information)	EK-OTS11-UG

All TS11 options are covered by the following Illustrated Parts Breakdowns (IPBs).

872 Power Controller	EK-00872-IP
861 Power Controller	EK-00861-IP
TS11 A (standalone)	EK-TS11A-IP
TS11 B (TS11 A and H9502 cabinet)	EK-TS11B-IP
TS11 C (TS11 A and H9546 cabinet)	EK-TS11C-IP
TS11 D (TS11 A and H950 cabinet)	EK-TS11D-IP

## 1.8 PDP-11 BASED DIAGNOSTICS

Paragraph 3.8 provides operational details for the following tests.

### **Transport Control Logic Test (CZTSI)**

This test causes data-wraparounds through the TS11, the serial bus, the I/O silo, and the formatter. The output of this test calls out a failing module when an error occurs.

### **Transport Data Reliability Test (CZTSH)**

This test simulates a worst-case operating environment for the transport by executing commands in random order, with random record lengths and data. This test is mainly a confidence test.

#### **NOTE**

**Rev C or higher Rev of this diagnostic should be used.**

### **DEC/X11 System Exerciser (CXTSAAO)**

This diagnostic can exercise up to four TS11s by doing a write, read reverse, in-core compare, read forward, in-core compare. Nonstandard printouts are used. See the diagnostic listing for operation.

## 1.9 VAX-BASED DIAGNOSTICS

Paragraph 3.9 provides operational details for the following tests.

### **Data Reliability Diagnostic (EVMAA)**

This test performs a complete check of the tape system. It allows the operator to test the tape system without bringing the system down. The diagnostic contains two sections: the qualification test and the Data Reliability Test.

### **Subsystem Repair Diagnostic (EVMAD)**

This is a standalone diagnostic that tests from 1 to 16 TS11 subsystems. The diagnostic provides fault detection/isolation to the module level whenever possible.

## 2

# INSTALLATION

### 2.1 M7982 INSTALLATION

Table 2-1 lists M7982 vector and address settings. Table 2-2 gives an example of these settings, and Figure 2-1 indicates switch locations on the TS11 interface module. Figure 2-2 shows a typical subsystem configuration.

**Table 2-1 Interrupt Vector and Address Assignments**

TS11	Interrupt Vector	UNIBUS Address	Register
1	224	772 520 772 522	TSBA/TSDB TSSR
2	Floating rank 37	772 524 772 526	TSBA/TSDB TSSR
3	Floating rank 37	772 530 772 532	TSBA/TSDB TSSR
4	Floating rank 37	772 534 772 536	TSBA/TSDB TSSR

### 2.2 INSTALLATION CHECKLIST

Use this procedure to install the TS11 subsystem.

1. Unpack and place.
2. Inspect for the following things.
  - Shorted pins
  - Broken components
  - Proper card seating
  - Complete plug seating
3. Set M7982 address and vector switches.
4. Remove the bus grant card (G727, G7270).

Table 2-2 Address and Vector Examples

Address					
7	7	2	5	2	0
x x x	x x 1	0 1 0 1 0 1 0 1 0	0 1 0	0 x x	
	E34	E90			
x x x	x x 1	1 10 9 8 7 6	5 4 3 2	x x	
x x x	x x off	on off on	off on off	on off on	on x x
Vector					
0	0	0	2	2	4
x x x	x x x	x x x	0 1 0 0 1 0	1 x x	
			E34		
x x x	x x x	x x x	8 7 6 5 4 3 2	x x	
x x x	x x x	x x x	on off on	on off on	off x x

5. Cut CA1 to CB1 (NPG) jumper on the SPC backplane slot.
6. Insert the 7-foot adapter cable into the M7982 module with the red reference edge toward the handle.
7. Insert the M7982 module into any available SPC slot.
8. Connect interface cable to CPU bulkhead and I/O connector bracket on rear of TS11 (Figure 2-3).
9. Verify correct voltage and frequency at the rear of the transport.

#### NOTE

When 50 Hz power is used, both switches on the G158 board must be in the open, or off, position. (At 60 Hz both must be closed, or on.) Also, verify that the ac input box (TS11 power supply) is correct. It is necessary to check the tension arm adjustment when changing from 60 Hz to 50 Hz power.

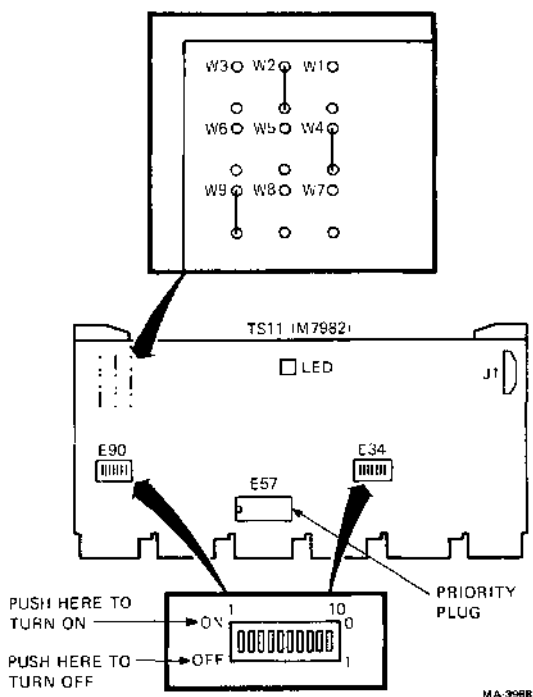

MA-398B

Figure 2-1 M7982 Interface Module

10. Power up the transport and verify all voltages. (Refer to Paragraph 5.1).
11. Place the transport in maintenance mode and view the PC lights. Check for errors.
12. Load a tape (tape will not be positioned at BOT).
13. Run internal diagnostics, the control logic test, then the data reliability test. (Test 47 fails in autosequence mode if the M7982 is not powered up.)

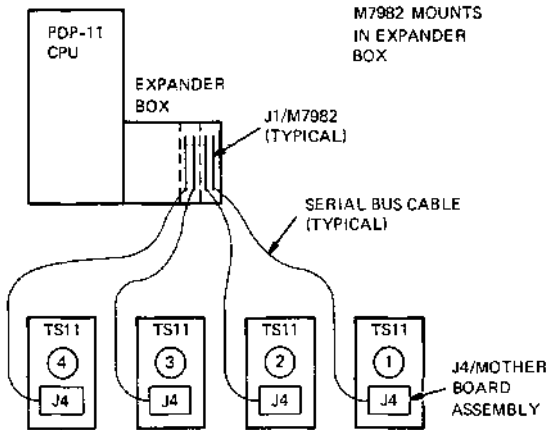

NOTE:  
NPG JUMPER, CA1 TO CB1,  
FOR EACH M7982 SLOT  
MUST BE CUT.

MA 3986

Figure 2-2 Typical Subsystem Configurations

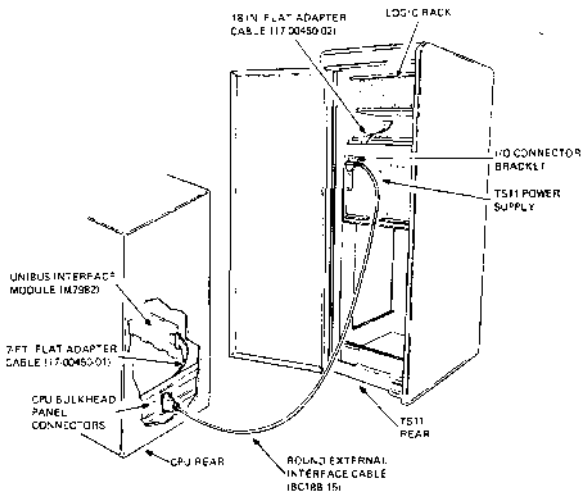

VA 007-62  
SMP 001-64

Figure 2-3 TS11 Signal Cabling



# 3 TROUBLESHOOTING

## 3.1 GENERAL

Paragraphs 3.2, 3.3, and 3.4 describe microdiagnostics; Paragraph 3.5 details error codes and error tables. Paragraph 3.6 describes microdiagnostic operation; Paragraph 3.7 describes the customer confidence check. Paragraph 3.8 describes PDP-11 based diagnostic operation and Paragraph 3.9 lists special troubleshooting aids.

## 3.2 INTERNAL MICRODIAGNOSTICS (IN-LINE)

These five tests verify basic microprocessor operation. They run when the transport is powered up and has not executed a subsystem command for approximately 500 milliseconds. Brief test descriptions follow.

### 3.2.1 UTSTM

This tests the M8962, M8964, and M8968 boards and checks all transport instructions, the input bus, and the output bus.

### 3.2.2 STAKM

This tests the 64-byte push/pop RAM on the M8963 board and communications with the G159 board. Also, STAKM tests parity, overflow detection, attention branch logic, and the attention register of the stack. It performs a data wraparound on the capstan bus and checks the CBus and branch logic.

### 3.2.3 IOTSM

This tests the M8965, M8966, and M8967 boards and attention logic on M8963. IOTSM performs a simple handshake over the TS11 bus.

### 3.2.4 CATSM

This tests the G159 and the remainder of M8963 not checked by STAKM and IOTSM. CATSM checks the 1 KHz clock, simulated capstan motion, and the logic part of the digital servo system.

### 3.2.5 PETSMT

This tests some of M8923, G157, M8929, M8924, and M8922. It checks M8929 clock logic and silo interface to the M8966, G157, and M8923 pulse generators. Also checked is the center frequency of VCO on M8922 and M8924 window logic. PETSMT checks data through the G157, M8923, M8924, and M8922 boards. PETSMT performs XORs and checksums for the formatter table look-up ROMs on the M8922 board.

### 3.3 INITIALIZATION MICRODIAGNOSTICS

These tests are internal (in-line) diagnostics but run under special conditions to check more hardware. They alter registers in the transport and reset them to a specific initial value. If a customer operation was taking place when these were invoked, data could be altered. These diagnostics are invoked by power-up, maintenance panel reset, subsystem initialize, or the UNIBUS initialize.

### 3.4 OFF-LINE MICRODIAGNOSTICS (CUSTOMER CONFIDENCE AND MAINTENANCE TESTS)

These tests check transport operations including tape motion, read data, and write data. A *special test tape* must be loaded on the transport to run the off-line tests. Table 3-1 briefly describes each test.

Table 3-1 Test Descriptions

Test	Description
1	Field Service PM Test (Test 0 is illegal) – Causes tests 2 through 47 to auto sequence to completion or error.
2	Capstan Board Clock Test – Tests capstan 1 ms clock, TAC sync flop, and TAC attention logic.
3	Capstan Simulated Motion Forward Test – Sets capstan maintenance signal to prevent motion and simulates acceleration and deceleration. In forward, capstan should not move; reel motors may shift position slightly.
4	Capstan Simulated Motion Reverse Test – Same as test 3, but in reverse.
5	Reel Motors Off Test – Turns reel motors off and checks G159 board for negation of REEL MOTOR ON signal.
6	Reel Motors On Test – Same as test 5, but turns motors on and looks for assertion of signal.

Table 3-1 Test Descriptions (Cont)

Test	Description
7	Tach Phase Forward Test – Checks tach phase duty cycle and relationship between tach phases 1 and 2 in forward.
<b>NOTE</b> If a tach slot is bad, it may not appear on the scope (because of 500 others) but the test will detect it.	
10	Tach Phase Reverse Test – Same as test 7, but in reverse.
11	Forward Speed Test – Checks forward capstan speed.
12	Reverse Speed Test – Checks reverse capstan speed.
13	Capstan Deceleration Test – Checks capstan stop time in number of ticks.
14	I/O Micro Basic Test – Checks I/O micro attention logic and data path.
15	I/O Micro Flag and Frame Counter Test – Rechecks data path, sets and resets I/O flag bits, clocks and rotates a pattern through frame counter.
16	I/O Silo Good Parity Data Test – Writes I/O silo with good parity and returns it to main micro with silo parity error register to check for errors.
17	I/O Silo Bad Parity Data Test – Same as test 16, but causes bad parity and looks for error in silo parity error register
20	I/O Looparound Zeros Test – Writes into I/O extended address, OP code, and shift registers, then shifts eight times and looks for error.
21	I/O Looparound Ones Test Wraparound – Same as test 20, but with ones to test for bits that cannot be set to one.
22	I/O Looparound MUX Test – Checks I/O's ability to multiplex shifting sequence from 5-bit to 21-bit, to 23-bit shift, checks I/O STWORD and STBYT instructions.
23	Write Board Clock Test – Fills I/O silo with data and checks M8929's ability to empty silo at three selectable data rates.

Table 3-1 Test Descriptions (Cont)

Test	Description
24	Formatter Flag and Sync-Up Test – Sets and clears formatter flag control bit, and tests write board formatter and silo for sync-up time by writing special pattern into I/O silo and timing formatter's time to fill up formatter's silos (done in formatter wraparound mode).
25	Formatter Peak Shift and FWD/REV MUX Test – Checks formatter's ability (M8924 boards) to shift data and phase window to follow peak shift and FWD/REV MUX (M8923 and G157).
26	Formatter Table Look-Up ROM Checksum Test – Checks M8922 ROMs by checksum testing all ROM locations.
27	Not used
30	Not used
31	Skew Meter Calibration Test – Checks skew meter circuit with microprocessor-generated data.
32	Data Head Test – Writes data at 40 percent threshold and verifies each head, five out of eight 64-byte bursts can be read without error.
33	Erase Head Test – Checks that erase head can reduce residual tape signal to less than 7 percent.
37	Feedthrough Test – Checks for noise when reading during write at 7 percent threshold.
40	Tracking Test – Checks that tape path across head is same in forward and reverse.
41	PE Data Test – Writes 72 records at normal thresholds; sets errors for more than four bad records.
42	PE Data Test – Writes 72 records, reads reverse without checking errors, and reads forward at 40 percent threshold; sets error for more than 30 bad records.
43	PE Data Test – Writes 72 records and reads reverse at 40 percent threshold; sets error for more than 30 bad records.
44	PE Signal Sag (RD FWD) – Writes 64 records and positions back and forth over data 10 times, checks to read 32 or more records at 40 percent threshold on final read forward.

Table 3-1 Test Descriptions (Cont)

Test	Description
45	PE Signal Sag(RD REV) Test – Same as Test 44 but read reverse is final operation.
46	Rewind Test – Checks that rewind stops at BOT and no limit switch error.
<b>NOTE</b> This test may be used to rewind tape if M7982 is not powered up.	
47	I/O Serial Bus Wraparound Test – Checks basic serial bus operation, also, sends out bad serial bus parity to the UNIBUS interface to set SPE bit in TSSR after this test.
<b>NOTE</b> This test fails if M7982 is not powered up.	
Auto sequence stops here. Tests 34, 35, and 50 through 57 run manually only	
34	Minimum Amplitude Test – Checks capability to read most 3200 FCI data written at 80 percent threshold.
35	Maximum Amplitude Test – Checks capability to prevent reading most 3200 FCI data transitions when written at 120 percent threshold.
50	Forward/Reverse Skew Test – Checks head skew in forward and reverse.
<b>NOTE</b> A skew tape must be mounted for proper operation.	
51	Forward Read Test – Causes normal PE read cycle, forward at BOT, reverse at EOT.
52	Reverse Read Test – Causes normal PE read cycle, forward at BOT, reverse at EOT.
53	Write Zeros Test – Causes 256 character, all zero records to be written on tape, rewinds when EOT is hit.
54	Write Alternating Ones Test – Same as test 53 with alternating ones pattern. (Parity track will always be a one.)
55	Stack Test – Causes stack verify test to loop with good and bad parity; if error, will halt at 1772–1774.

**Table 3-1 Test Descriptions (Cont)**

Test	Description
56	CBus Test – Causes CBus communication test to loop; if error, will halt at 1775–1777.
57	Manual Switch and Light Test – Scans reel motors on, operator panel switches, limit switches, write lock switch, and BOT/EOT sensors; these are then displayed in operator panel indicators.

### 3.5 ERROR CODES

This section describes the three error code classes and defines the error codes.

#### 3.5.1 Fatal Errors

These errors are caused by a failure in the main micro and are identified by all operator panel indicators off and the CLK STP and CROM PERR indicators on. The PC indicators show the fatal error. Accepted range is from 1750–1777. Values outside this range indicate CROM parity errors. Table 3-2 lists the fatal error, error description, and the module that probably failed.

#### NOTE

**The display in the operator panel indicators and switches at this point may not apply to the error.**

**To loop microdiagnostics on error halt, raise the override (OVR) switch. Set the HALT/RUN switch to halt (for single step). Set the HALT/RUN switch to run to loop continuously. Press the step switch to recycle.**

Table 3-2 Fatal Microprocessor Errors

Error (PC Counter) Test	Error Description	Probable Module	
1750	<p>Main micro detected CROM parity error in I/O during operational code.</p> <p>OP END entry called at wrong time; microcode bug halt.</p> <p>IOM received bad data from I/O at end of data operation when expecting record-length flags; probably means I/O micro problem.</p> <p>Start I/O operation called at wrong time; probably microcode bug.</p>	M8967	
1751	DISPM	Spurious ATTN (Noise on .NATTN line?)	M8963
1752	DISPM MTCTM	Fatal stack parity error or overflow error occurred; may be hardware failure of stack board or microcode stack bug halt.	M8963
1753	DISPM	Stack not empty and nothing more to do. May be hardware stack pointer problem or microcode bug (too many pushes or pops).	
	MTCTM	Maintenance mode fatal microcode bug halt.	
1754	UTSTM	Stack pointer will not hold data.	M8962 M8963 M8964
1755	UTSTM	Failure of one of branch tests	M8964 M8968 M8962
1756	UTSTM	Failure of Z bit test - (Z bit says result of last arithmetic operation was zero.)	M8962 M8964

Table 3-2 Fatal Microprocessor Errors (Cont)

Error (PC Counter) Test	Error Description	Probable Module
1757 UTSTM	Failure of N bit test – (N bit says result of last arithmetic operation was negative or OBus bit 7 was a one during last instruction.)	M8962 M8964
1760 UTSTM	Failure of C bit test – (C bit says result of last arithmetic operation should have caused carry out of high order stage of ALU.)	M8962 M8964
1761 UTSTM	Failure of ones (not Z) test – the Z bit was set even though result of last operation was non-zero.	M8962 M8964
1762 UTSTM	Failure of write/read external test – unsuccessful attempt to write and read an external register (the PC buffer).	M8964 M8962
1763	Failure of register address/data test – each internal register written with its own number, but gave discrepancy when read back.	M8962
1764 UTSTM	Failure of register test 2 – each register written with complement of its own number, but gave discrepancy when read back.	M8962 M8964
1765 UTSTM	Failure of add arithmetic function	M8962 M8964
1766 UTSTM	Failure of ASUB test	M8962 M8964
1767 UTSTM	Failure of BSUB test	M8962 M8964
1770 UTSTM	Failure of shift test – unsuccessful attempt to shift (rotate) data left or right.	M8962 M8964



Table 3-2 Fatal Microprocessor Errors (Cont)

Error (PC Counter) Test	Error Description	Probable Module
1771 UTSTM	Failure of logical operands test (AND, OR, NAND, XOR, etc.)	M8963 M8964
1772 STAKM	Failure of stack parity test – bad parity written into the stack, but stack parity error not detected.	M8963
1773 STAKM	Failure of stack underflow/overflow test – attempted to push data on stack past location 77 (overflow) or pop data off stack past location zero (underflow), and did not get error (or attention condition).	M8963
1774 STAKM	Failure of stack address data test – some location(s) of stack do not contain correct data after being written.	M8963
1775 STAKM	Failure of capstan bus data-wrap test – data written into light register and different data read back.	G159 M8963 CBus cable
1776 STAKM	Failure of CBus branch condition test.	M8963
1777 STAKM	Failure of limit attention flag – LIMIT ATTN was enabled, and status of limit switch does not agree with corresponding position in attention register.	M8963

### 3.5.2 Nonfatal Errors

Errors are identified by CLK STP off and operator panel indicator values from 100–337 (octal). Table 3-3 lists error code, error description, the module that probably failed, and scope loop.

#### NOTE

**This error table is valid when in-line or initialize microdiagnostics are running. If off-line tests are run, see Off-Line Test Errors.**

**To scope loop these tests, enter maintenance mode (ON-LINE switch to off position, MAINT MODE switch up, press RESET). Enter the off-line test number (see the scope loop column in Table 3-3) in the operator console lights, and press the ON-LINE switch. The test will loop until the ON-LINE switch is returned to the off-line position and errors are displayed continuously.**

Table 3-3 Nonfatal Microprocessor Errors

Scope Loop Test No.	Operator Panel Error (Octal)	Test	Error Description	Probable Cause
	337	Operational Code	Capstan runaway error-capstan did not stop within acceptable window after last command.	G159 capstan motor assembly
	300		Limited switch or Init. failure	
14	100	IOTSM	Basic I/O micro failure (parity error, IOATN, handshaking, and data window test between I/O and main micro)	M8967
<b>NOTE:</b>				
<b>Can also be caused by the serial bus .SHIN (shift in) stuck asserted</b>				
15	101	IOTSM	Error in I/O control register test	M8966 M8967

Table 3-3 Nonfatal Microprocessor Errors (Cont)

Scope Loop Test No.	Operator Panel Error (Octal)	Test	Error Description	Probable Cause
15	102	IOTSM	Failure of frame counter test	M8966 M8967
16	103	IOTSM	Failure of I/O silo nonparity error data test or write flag	M8966 M8963 M8967
17	104	IOTSM	Failure of I/O silo parity error test or data late test	M8966 M8967
17	105	IOTSM	Failure of shift loop with zeros	M8965
21	106	IOTSM	Failure of shift loop with ones	M8965
22	107	IOTSM	Failure of shift length multiplexer	M8965
47	110	IOTSM	Failure to receive correct operating code from TS11 when responding to data sent over SBus cable motherboard	M8965
2	111	CATSM	Failure of 1 KHz clock test, also test tach sync flop	G159 M8963 CBus cable
3,4	112	CATSM	Light register changed when motion register cleared.	G159
3,4	113	CATSM	FWD or MVG bits wrong after one tick of simulated command, and tach pulses.	G159
3,4	114	CATSM	Failure of simulated capstan speed test; speed counter was out of range when tape motion at speed was simulated.	G159

Table 3-3 Nonfatal Microprocessor Errors (Cont)

Scope Loop Test No.	Operator Panel Error (Octal)	Test	Error Description	Probable Cause
3,4	115	CATSM	Failure of simulated slow capstan test; speed counter did not latch up with maximum count when slow tach ticks were simulated	G159
3,4	116	CATSM	Failure of simulated capstan deceleration test; counter not zero for forward or 377 for reverse while decelerating, or MVG Bit NCT 1	G159
3,4	117	CATSM	Failure of moving flop to go to zero after stopping (direction reversal for one tach tick)	G159
23	120	PETSM	Failure of write board to turn on and empty silo, or data late bit does not work.	M8929 M8966
24	121	PETSM	Failure of write board to empty silo at correct speed	M8922
24	124	PETSM	Formatter flag does not work on M8922.	M8922
24	125	PETSM	Formatter silo filling and data error	M8922 VCO Adj.
25	126	PETSM	Peak shift test error	M8924 M8922 M8923
26	127	PETSM	Formatter table lookup ROM checksum test error	M8922 M8923 M8924

### 3.5.3 Off-Line Test Errors

These errors occur only when running off-line tests. If running in auto-sequence mode the failing test is displayed first. This failing test can be entered to run in standalone mode. The resulting error code in the operator panel describes the failure and the module that probably failed. Section 3.6 explains how to run off-line tests. Table 3-4 lists the failing test, operator panel indication, error description, and probable cause. The asterisks (\*) indicate customer confidence tests.

**Table 3-4 Customer Confidence or Maintenance Mode Test Errors**

Scope Loop Test No.	Operator Panel Error (Octal)	Error Description	Probable Cause
1	Various	Indicates failed test number.	See Failed Test description.
2	111	1 msec capstan clock off speed TAC sync flop; or TAC ATTN signals not working.	M8963, G159, Motherboard CBus cable
3-4	112	Operator panel affected by WRT CLR to MOT, REG.	G159, CBus cable
3-4	113	MVG or FWD/REV flop not okay.	G159, CBus cable
3-4	114	SPD REG out of tolerance (on speed).	G159, CBus cable
3-4	115	SPD REG wrong (slow speed).	G159, CBus cable
3-4	116	SPD wrong (deceleration).	G159, CBus cable
3-4	117	MVG not set during deceleration.	G159, CBus cable
5*	1	Reel motors off; REEL MOTORS ON signal was one.	G158, G159, reel motor, CBus cable

Table 3-4 Customer Confidence or Maintenance Mode Test Errors (Cont)

Scope Loop Test No.	Operator Panel Error (Octal)	Error Description	Probable Cause
6*	1	Reel motors on; REEL MOTORS ON signal was zero.	G158, G159, reel motor
7-10*	4	Phase angles confused.	G159, tach adj., capstan assembly or motor
7-10*	3	Phase exceeded limit.	G159, tach adj., capstan assembly or motor
11-12*	2	Capstan speed too fast.	G159
11-12*	1	Capstan speed too slow.	G159
13*	10	REV overshoot, too many ticks to stop REV.	G159, decel. adj.
13*	4	REV undershoot, too few ticks or bounced back.	G159, decel. adj.
13*	2	FWD overshoot, too many ticks to stop FWD.	G159, decel. adj.
13	1	FWD undershoot, too few ticks or bounced back.	G159, decel. adj.
14	100	I/O Micro step, I/O	M8967, M8963
15	101	IOCNO register test	M8967
15	102	Frame counter test	M8966
16	103	Silo good parity data flag	M8966, M8963
17	104	Silo bad parity, data late	M8966

Table 3-4 Customer Confidence or Maintenance Mode Test Errors (Cont)

Scope Loop Test No.	Operator Panel Error (Octal)	Error Description	Probable Cause
20	105	I/O looparound, zeros	M8965
21	106	I/O looparound, ones	M8965
22	107	I/O looparound, shift length multiplexer	M8965
47	110	Serial bus/TS11 alive.	M8965, M7982, Motherboard
23	120	I/O silo not being clocked by write board.	M8929, M8966
23	121	WRT BD silo CLKT out of range.	M8929
24	124	FMT FLG in FMT CNTL REG test	M8922, VCO adj.
24	125	PE FMT mode, data, silo	M8922, M8923, M8924 G157, VCO adj.
25	126	PE FMT early/late bit shift test	M8922, M8923, M8924 G157, VCO adj.
26	127	PE FMT table look up ROM checksum test	M8922
31	2	Skew limit too loose, turn R49, M8923 counterclockwise.	M8923, G157
31	1	Skew limit too tight, turn R49, M8923 clockwise.	M8923, G157
32*	200	Track active data error	G157, cables, M8929, G057, Head

Table 3-4 Customer Confidence or Maintenance Mode Test Errors (Cont)

Scope Loop Test No.	Operator Panel Error (Octal)	Error Description	Probable Cause
33	100		Erase head
34-35	100	Data timeout if data expected, TST 32, 34, noise when no data expected, TST 33, 35-40.	G057, M8922, preamp adj.
37*	17	Bit in error, (10 is parity track; decode to bit weight).	Head
40*			Head
41-45*	200	Fatal error, limit exceeded/no data.	Media, head, threshold adj.
51-54	100	Data error, VCO lost sync.	M8922, M8924, M8929 threshold adj.
	40	Tape mark seen.	M8922, M8924, M8929 threshold adj.
	20	Data error VCO still synced.	M8922, M8924, M8929 threshold adj.
50	2	Reverse skew error	Head skew adj., tape path, head
50	1	Forward skew error	Head skew adj., tape path, head
57	200	Reel motors on	Switches, sensors
57	100	ON-LINE switch in (lights ON-LINE)	ON-LINE switch (G159)
57	40	Limit switch exceeded, latch set (all limit switches lights MICRO OK).	Limit switch



Table 3-4 Customer Confidence or Maintenance Mode Test Errors (Cont)

Scope Loop Test No.	Operator Panel Error (Octal)	Error Description	Probable Cause
57	20	LOAD switch in (LOAD switch lights VOL VALID).	LOAD switch (G159)
57	10	Enter zero switch in (EOT switch lights DENS ERROR).	EOT switch (G159)
57	4	Write lock lever out WRT Locked (Write lock lever lights WRITE LOCK).	Write lock assembly
57	2	BOT latch set (BOT sensor lights BOT.)	BOT/EOT sensor
57	1	EOT latch set (EOT sensor lights EOT.)	BOT/EOT sensor

**NOTE**  
Test 57 loops on itself. The loop is broken by pressing the maintenance panel RESET pushbutton.

### 3.6 HOW TO RUN MICRODIAGNOSTICS

This section describes how to run the internal and off-line diagnostics.

#### 3.6.1 Internal Microdiagnostics (In-Line)

These tests run by themselves when the transport is idle for more than 500 milliseconds. They cause fatal and nonfatal errors.

#### 3.6.2 Internal Microdiagnostics (Initialization)

These tests are a superset of in-line diagnostics, and test more logic. They are initiated by a power-up, maintenance panel RESET, subsystem init or UNIBUS init. They cause more fatal and nonfatal errors.

### 3.6.3 Off-Line Microdiagnostics (Customer Confidence and Maintenance)

A write-enabled *special test tape* must be loaded on the transport. Set the MAINT MODE/NORMAL switch on the maintenance panel to MAINT MODE. The operator panel now operates in maintenance mode with the ON-LINE switch out. Enter the off-line test in the operator panel (in octal notation). (The leftmost switch puts a one in LSB and the rightmost switch puts a zero in LSB. The value shifts left after each entry.) Test 1 is autosequence mode; tests 2 through 47 run consecutively. The ON-LINE switch is now a start/stop switch. Press the switch to latch it in and the selected test will run; press it a second time to release it and the test will stop. A new test can be selected whenever the start/stop switch is in the stop position. Successful completion in auto-sequence mode is shown by a rotating pattern in the operator panel (only when connected to a TS11 with power applied). Exit to normal operations by setting the MAINT MODE/NORMAL switch to NORMAL and replace the scratch tape.

### 3.7 CUSTOMER CONFIDENCE CHECK

The customer confidence test is a subset of off-line tests. It can run without going inside the cabinet and setting the maintenance switch. The test is run by the operator to verify the drive. A Field Service *special test tape* must be loaded (LOAD light on), off-line, and write-enabled. Press the LOAD and EOT panel pushbuttons together. The display now shows 300 indicating the customer confidence tests will run as soon as you press the ON-LINE switch on. If a test fails, the test number flashes in the indicators. If all tests pass, the indicators display a rotating pattern. To return the drive to normal operation at any time, press the ON-LINE switch again so the switch is released.

### 3.8 OPERATING PDP-11 BASED DIAGNOSTICS

Use this procedure to operate PDP-11 based diagnostics.

1. Load XXDP+ monitor.
  - a. Enter date.

2. Answer hard core questions.
  - a. 50 Hz? Y or N
  - b. LSI? Y or N  
 This is XXDP+. Type H or H/L for details (help file).  
 [Receive XXDP+ prompt.(dot)]
    -
3. Enter R (space) program.  
 The program is CZTSI or CZTSH etc.  
 The operator entry should look like this:  
 [.R ZTSI??]
4. Receive DR> prompt.
5. Enter the appropriate command. For example, DR>  
 STA for start.
6. Change HW (L) ?
7. Change SW (L) ?

**NOTE**

**The answer to Change HW(L)? must be YES to allow the diagnostic to run. Refer to the diagnostic listing for specific program problems.**

**3.8.1 Data Reliability Program Tests**

- |        |                                   |
|--------|-----------------------------------|
| Test 1 | Basic functions                   |
| Test 2 | Data reliability                  |
| Test 3 | Write compatibility/write utility |
| Test 4 | Read compatibility/read utility   |
| Test 5 | Operator selected sequence        |

**3.8.2 Control Logic Program Tests**

- |         |                             |
|---------|-----------------------------|
| Test 1  | PDP-11/TS11 wrap test       |
| Test 2  | PDP-11/transport wrap test  |
| Test 3  | Set character check         |
| Test 4  | Tract active/inactive test  |
| Test 5  | PE data test                |
| Test 6  | PE skew test                |
| Test 7  | Dead tracks test            |
| Test 8  | ROM look-up table test      |
| Test 9  | Inline microdiagnostic test |
| Test 10 | INIT microdiagnostic test   |

### 3.8.3 Program Control Flags

HOE	Halt on error, causing CMD mode to be entered when error
LOE	Loop on error, causing diagnostic to loop continuously within smallest defined block of coding (segment, subtest, or test)
IER	Inhibit error reporting
IBE	Inhibit basic error reports
IXE	Inhibit extender error reports
PRI	Direct all messages to line printer
PNT	Print number of test being executed
BOE	Bell on error
UAM	Run in unattended mode, bypassing manual intervention tests
ISR	Inhibit statistical reports
IDU	Inhibit dropping of units by diagnostic

### 3.8.4 Hardware Parameters

The following are base address and vector assignment default parameters.

TSSR ADDRESS (172522) ?  
VECTOR (224) ?

Example of STA/TES:2/FLA:IDU:LOE  
commands:

Example meaning: Start test 2, inhibit dropping unit, and loop on error.

### 3.8.5 Software Parameters (Data Reliability Program Only)

Refer to diagnostic listings.

**3.9 OPERATING VAX-BASED DIAGNOSTICS**

Use this procedure to operate VAX-based diagnostics.

1. Load Diagnostic Supervisor (ESSAA or EXSAA).
2. Load and start diagnostic.

- a. EVMAA

```
DS> ATTACH DW750 HUB DWO
```

```
DS> ATTACH TS11 DWO.MSA0 772520 224 5
```

```
DS> SEL MSA0
```

```
DS> RUN EVMAA
```

- b. EVMAD

```
DS> ATTACH DW750 HUB DWO
```

```
DS> ATTACH TS11 DWO.MSA0 772520 224 5
```

```
DS> RUN EVMAD
```

**3.9.1 Data Reliability Test Sections**

1. Qualification Test
2. Data Reliability Test
3. Multi-Drive Test
4. Conversation Mode Test

**3.9.2 Subsystem Repair Test Sections**

1. Default - Runs Test 1-36
2. Manual - Runs Test 37-40
3. All - Runs all Test

**3.9.3 Control Flags**

Refer to diagnostic listing.

**3.10 SPECIAL PROCEDURES**

Use this special procedure to bring up the system when it is "dead in the water." This means nothing else works (tape cannot be loaded or microdiagnostics run) and the power is okay. There are two probable causes; one of the modules that makes up the microprocessor or control read only memory (CROM) is not working, or a module that hangs on the microprocessor buses is hanging a bus.

Hardware and microcode are structured so that all modules except the main micro and main ROM board can be removed from the system and then added one by one until a failure occurs. The diagnostic senses the modules as they are added and expands the test loop to encompass the new board functions. Perform the following initial set-up procedures.

1. Power off.
2. Remove all PC cards in the logic rack except M8962 (microprocessor) and M8964 (PC and ROM 1).
3. Remove the cable from J-2 on backplane. This disconnects G159 (capstan servo board).
4. Remove the cable from J4 on backplane (disconnects TS11 UNIBUS Interface Card M7982).
5. Set the MAINT MODE switch to NORMAL, the ENABLE ERROR switch to ENABLE and the HALT/RUN switch to RUN.

Starting with only the M8962 and M8964 installed, perform the following test sequence procedure.

1. Power up.
2. Wait 20 seconds.
3. Press RESET on the maintenance panel.
4. Table 3-5 lists the correct contents of the maintenance panel and operator panel displays. If the display differs, the last module added is bad.
5. If all display indicators are correct, perform these steps.
  - a. Power off.
  - b. Insert the next card listed in the add column of Table 3-5.
  - c. Go back to step 1 and continue testing.

### 3.10.1 Dead Track Card Identifier

Using Data Reliability Program (CZTSH) Test 2 on PDP-11 Systems or Data Reliability Program (EVMAA) Section 2 on VAX Systems, Table 3-6 shows which card is bad for each dead track recorded in extended status register 2 (XSTAT2).

Table 3-5 Bring-Up Procedure Errors

Add	Maint. Panel CLK STOP	CROM PERR	Front Panel Lights (octal)	Comment
M8962	off	off	N/A	Loop basic micro test
M8964 REV C M8968 REV F	off	off	N/A	Loop basic micro test
M8963	on	on	N/A	Control bus test
G159 cable J2 on backplane	off	off	100	Basic IC test
M8967 REV D	off	off	100	Frame control test
M8966	off	off	103/100	I/O silo test
M8965	off	off	110	Serial bus wrap test
M7982	off	off	120*	Write board/silo test
M8929	off	off	124	PE FMT flag test
M8922 and interconnect jumper	off	off	125	PE silo test
M8923, M8924, G157	off	off	Micro okay	System up (VCK ok) VOL VALID indicator on

\* 110 if host CPU power off.

#### NOTE

The indications in this table are correct for the highest REV level of the modules listed. Other REV levels may show a different indication.

If the operator panel display does not appear in Table 3-5, and the last module added is not the cause, check the nonfatal microprocessor errors in Table 3-3 for the probable cause.

Table 3-6 Dead Track/Module Locations

Dead Track	Bit	Head TK	Slot/Card	Most Likely Bad Slot/Card
1	0	2	2 = G157	6 = M8924
2	1	8	2 = G157	6 = M8924
4	2	1	1 = G157	6 = M8924
10	3	9	1 = G157	5 = M8924
20	4	3	1 = G157	5 = M8924
40	5	5	2 = G157	5 = M8924
100	6	6	2 = G157	4 = M8924
200	7	7	1 = G157	4 = M8924
400	P	4	3 = M8923	4 = M8924



# 4 REMOVAL AND REPLACEMENT

This chapter provides removal or replacement procedures for parts listed in the spares kit list. Complete procedures for all replaceable parts are found in the *TS11 Technical Manual*.

## 4.1 SPECIAL PROCEDURES

Several pieces of the spares kit require no special removal or replacement procedures. Except where noted, no adjustment is required after replacement. Follow normal safety precautions. One module (G158 reel servo board) has line voltage exposed on its surfaces. Always remove power when replacing parts on this unit. The following spares require no special procedures.

- Pico fuses (Digital PN 12-05747) – Refer to Figure 1-3.
- Maintenance panel LED (Digital PN 11-10324) – Refer to Figure 1-7.
- Maintenance panel switches

Toggle (Digital PN 12-09590) – Refer to Figure 1-7.

Pushbutton (Digital PN 12-11079) – Refer to Figure 1-7.

- Limit switch (Digital PN 70-15666) – Check tension arm mechanical adjustment (Figure 5-1).
- Operator panel indicator (Digital PN 12-12716-01) – General Electric 73 (Figure 1-5).
- Operator panel indicator covers – (Paragraph 1.6) Refer to Figure 1-5.

## 4.2 MODULE REPLACEMENT

Table 4-1 lists adjustments to check and perform, as needed, whenever a module is replaced. The adjustments are found in Chapter 5.

Table 4-1 Module and Adjustment Number

Module	Adjustment
M7982	See installation section. Set address and vector switches.
M8922	VCO
M8923	Threshold; skew meter
M8924	*
M8929	*
M8962	*
M8963	*
M8964	*
M8965	*
M8966	*
M8967	*
M8968	*
G057	Preamplifier amplitude
G157	*
G158	Set S1 for appropriate frequency. (Check adjustment tension arm.)
G159	Capstan nulk; Capstan deceleration

\* None

### 4.3 OPERATOR PANEL (G159 MODULE)

This panel is an integral part of the G159 module. If necessary, replace G159 and perform the adjustments shown in Table 4-1. Test switches by using off-line test 57.

### 4.4 BOT/EOT SENSOR (DIGITAL PN 12-11720-00)

When replacing a new sensor, ensure that its face is parallel with the tape path.

### 4.5 CAPSTAN WHEEL (DIGITAL PN 74-18010)

The following procedures describe capstan wheel removal and replacement. A capstan clamp (Digital PN 74-18021) may be necessary to perform this procedure.

#### 4.5.1 Removal

1. Use the Allen wrench to loosen the capstan clamp at the rear of the capstan wheel.
2. Once loose, pull forward until the wheel is free.

### 4.5.2 Replacement

1. Carefully place the new wheel over the capstan motor shaft. Align the wheel flush with the capstan motor shaft.
2. Holding the wheel firmly in place, tighten the capstan clamp with the Allen wrench. Check tape path alignment and tape tracking.

## 4.6 FIXED REEL ASSEMBLY

The following procedures describe fixed reel assembly removal and replacement.

### NOTE

**The fixed reel assembly (four pieces: rear flange, inner hub, front flange, and trim piece) fits against a hub adapter. Do not remove this adapter for normal servicing. A special gauge (Digital PN 96-07951) is provided in the spares kit to check the hub adapter height.**

### 4.6.1 Removal

1. Remove three phillips screws and carefully slide all four assembly pieces forward.

### 4.6.2 Replacement

1. Assemble all four pieces on the hub adapter individually, and align the screw holes as you go.
2. Insert screws and tighten in a clockwise sequence.

## 4.7 SNAP LOCK HUB ASSEMBLY (DIGITAL PN 12-13119)

The following procedures describe snap lock hub assembly removal and replacement.

### NOTE

**This assembly fits against a hub adapter. Do not move the hub adapter to remove or replace the snap lock hub assembly or bezel. A special gauge (hub height tool Digital PN 96-07951) is provided in the spares kit to check hub adapter height.**

#### **4.7.1 Removal**

1. Lift the locking tab and remove the index screw.
2. Rotate the outer hub counterclockwise to unscrew the hub from the hub adapter.

#### **4.7.2 Replacement**

1. Carefully thread the snap lock hub clockwise onto the hub adapter until fully seated with the snap lock open.
2. Back off the hub counterclockwise until the snap lock closes smoothly.
3. Use several reels of tape to check for smooth and firm snap lock action.
4. Locate the nearest index screw hole through the hub and reinstall the index screw.

### **4.8 LOWER ROLLER ASSEMBLY (FIXED ROLLER, DIGITAL PN 12-16060)**

The following procedures describe lower roller assembly removal and replacement.

#### **4.8.1 Removal**

1. Remove capstan wheel (Paragraph 4.5.1).
2. Remove fixed reel assembly (Paragraph 4.6.1).
3. Remove bezel covering the casting by removing eight screws from the rear of the casting (Figure 4-1).
4. Remove two screws from the roller assembly in front.
5. Lift out roller assembly.

#### **4.8.2 Replacement**

1. Screw new roller assembly in place with two screws.
2. Replace bezel by fastening eight screws in the rear of the casting) (Figure 4-1).
3. Replace fixed reel assembly (Paragraph 4.6.2).
4. Replace capstan wheel (Paragraph 4.5.2).
5. Verify tape tracking and tape path alignment (Chapter 5).

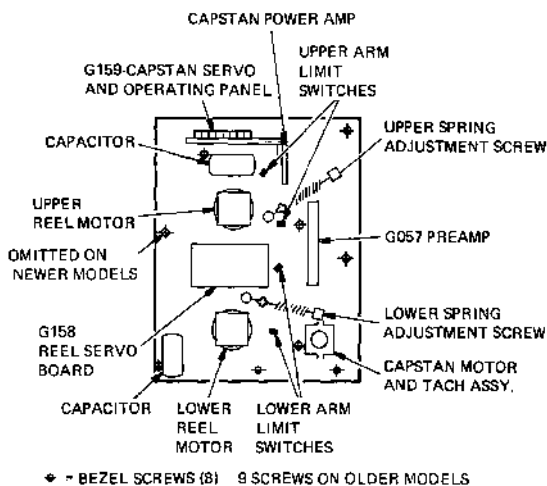

NOTE: IF THE UNIT CONTAINS A NEWER DECK PLATE THE BEZEL SCREWS WILL BE LOCATED IN THE FRONT OF THE DECKPLATE.

MA-4006

Figure 4-1 Deck Plate Assembly (Rear View)

#### 4.9 UPPER ROLLER ASSEMBLY (DIGITAL PN 70-13574)

This roller is part of the head assembly. If it fails, the head assembly must be replaced. Those procedures are found in the *TS11 Technical Manual*.

#### 4.10 TENSION ARM ASSEMBLY (DIGITAL PN 17-14014)

The following procedures describe tension arm assembly removal and replacement.

##### 4.10.1 Removal (Upper or Lower)

1. Remove capstan wheel (Paragraph 4.5.1).
2. Remove fixed reel assembly (Paragraph 4.6.1).
3. Remove bezel by unfastening eight screws from the rear of the deck plate (Figure 4-1).
4. While holding the tension arm spring, loosen and remove the tension block screw. Remove the tension spring from the transducer cable (Figure 4-1).

5. Unhook the transducer cable from the pin in the pivot arm housing.
6. Unscrew the three holding screws from the front of the deck plate and remove the arm assembly through the back of the deck plate.

#### 4.10.2 Replacement

1. Insert the new arm assembly into place through the rear of the deck plate. Ensure the opening in the pivot arm housing points to the tension block assembly (for the transducer cable), then secure with three screws.
2. Place the arm in a vertical position and attach the transducer cable to the pin in the pivot arm housing.
3. Prepare the tension block assembly by having the adjusting screw in place and ready to attach when spring tension is applied.
4. Attach the spring and adjust the tension screw several turns.
5. Adjust course spring tension by using the procedure in Chapter 5.
6. Replace the bezel by fastening eight screws in the rear of the deck plate (Figure 4-1).
7. Replace the capstan wheel (Paragraph 4.5.2).
8. Perform fine tension arm adjustment.
9. Check tape path alignment and tape tracking.

#### 4.11 AC INPUT/LINE FILTER BOX

There is no special procedure to remove or replace the ac input/line filter box. This is the only change for ac input voltage modification. Use Table 4-2 to select the proper parts.

**Table 4-2 120 V/240 VAC Input Part Numbers**

Voltage	Line Filter	Cord
120 V	Digital PN 70-16287-00	Digital PN 70-16295-00
240 V	Digital PN 70-16287-01	Digital PN 70-16295-01

# 5 ADJUSTMENTS

## 5.1 QUICK REFERENCE ADJUSTMENT SPECIFICATION

Table 5-1 provides a quick reference to the various TS11 adjustment specifications.

Table 5-1 Adjustment Specifications

Parameter	Specified Value	Test Points
<b>Supply Voltage</b>	(At motherboard)	
5 V Noise	5.0 to 5.2 Vdc ≤300 mV	J5-7 to ground (Adjust H744.)
+15 V Noise	14.5 to 15.5 Vdc ≤300 mV	J5-3 to ground (Adjust power line monitor/15 V regulator R24.)
-15 V Noise	-14.0 to -16.0 Vdc ≤300 mV	J5-11 to ground (No adjustment.)
Unregulated supply Noise	±15 to ±23 Vdc ≤300 mV	J1-3 (Capstan driver) +15 V to ground J1-4 (Capstan driver) -15 V to ground
<b>Tension (Coarse Adjustment)</b>		
Lower Arm	510 to 540 gm	
Upper arm	460 to 490 gm	
<b>Capstan Position On Shaft</b>	Flush with end of motor shaft	
<b>Limit Switches</b>	Does tension arm actuate switch	
<b>Hub Height</b>		
Upper Hub	Use hub height gauge.	Digital PN 96-07951
Lower Hub		

Table 5-1 Adjustment Specifications (Cont)

Parameter	Specified Value	Test Points
<b>Tension Arm Centering</b>		
Upper	Approx. center of swing	
Lower	Approx. center of swing	
Arm to limit switch distance	2 to 2.5 cm (0.75 to 1.0 in) (Running test 50)	Test 50
<b>Final Tension Adjustment</b>	See procedure.	
<b>Tape Path Alignment</b>	See procedure.  Tape centered on capstan  No tape in and out position change with tape motion (forward and reverse). No tape puckering at roller.	
<b>EOT/BOT Sensor</b>		
Sensor position	Parallel to tape	On G159
<b>Marker voltage</b>		
BOT off	<1 V	BOT, pin 5 E1
BOT on	>3 V	
EOT off	<1 V	EOT, pin 7 E1
EOT on	>3 V	
<b>Capstan Null</b>	-0.1 to +0.1 V	Red lead on capstan motor to ground (R26 on G159)
<b>Tachometer</b>		
<b>Duty cycle</b>		
(FWD) 01	45% to 55%	G159, pin 3 E29
02	45% to 55%	G159, pin 5 E29
<b>Phase shift</b>		
(FWD + REV)	81 to 99 degrees	



Table 5-1 Adjustment Specifications (Cont)

Parameter	Specified Value	Test Points
<b>Speed Test</b>		
Forward		
Period	242.5 to 257.5 $\mu$ s	G159, pin 3 E29
Jitter	less than 5 $\mu$ s	(Test 11)
Reverse		
Period	242.5 to 257.5 $\mu$ s	Pin 3 E29
Jitter	less than 5 $\mu$ s	(Test 12)
<b>Capstan Deceleration</b>		
Forward	Operator panel indicators (EOT,BOT) flicker equally.	Test 13 (R87-G159) Forward
Reverse	Operator panel indicators (DENS ERROR, WRITE LOCK) flicker equally.	(R95-G159) Reverse
<b>Skew Meter Calibration</b>	No operator panel lights on in test.	Test 31 (R49-M8923) Bottom potentiometer
<b>Preamp Amplitude</b>	See following.	Maintenance panel analog
Read after write amplitude Preamble (3200 FCI)	9.75 to 10.25 Vp-p	RD0-RDP (Test 54) With <i>special test tape</i>
Read after write amplitude Data (1600 FCI)	<16.7 Vp-p	
Read forward amplitude Data (1600 FCI)	$\geq$ 90% of above value	Test 51
Read reverse amplitude Data (1600 FCI)	Within $\pm$ 15% of above value	Test 52

Table 5-1 Adjustment Specifications (Cont)

Parameter	Specified Value	Test Points
<b>Threshold (During Data)</b>	0.8 to 1.0 V from ground	Channel 1, pin A3A1 on backplane Channel 2, pin RD0 on maintenance panel Test 54 with <i>special test tape</i>
<b>VCO Level shift (dc) between data and no data</b>	Minimal	Test 54 with <i>special test tape</i> VCO TP1 on M8922 and RD0
<b>Skew Forward</b>	$\leq 2.5$ V	Skew analog Test 51
<b>Reverse</b>	$\leq 3.0$ V	Test 52 (Use master skew tape.)
<b>Complete Microdiagnostics</b>	"Jackpot" in operator panel indicators	Test 1 (auto sequence)

## 5.2 ADJUSTMENT PROCEDURES

The following procedures describe the correct way to perform various TS11 adjustments.

### 5.2.1 Tension (Coarse Adjustment)

Refer to Figure 5-1 when performing this adjustment.

1. Power down the system.
2. Using a 1 ft length of tape with loops at each end, attach a force gauge to the upper arm as shown. Place the tape between the upper fixed guide and the upper roller guide. Pull the arm in the direction shown to the approximate center of its swing. Take care that the force gauge has been zeroed. Adjust the upper spring adjustment screw on the back of the deckplate until the gauge reads  $475 \text{ g} \pm 15 \text{ g}$ .
3. Using the same 1 ft length of tape, attach the force gauge to the lower arm as shown. Place the tape between the capstan and the lower roller guide. Pull the arm in the direction shown to the approximate center of its swing. With the gauge properly zeroed, adjust the lower spring adjustment screw on the back of the deckplate until the gauge reads  $525 \text{ g} \pm 15 \text{ g}$ .

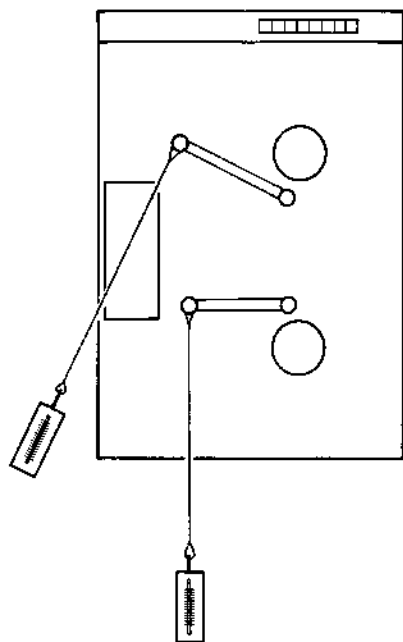

MA-3896

Figure 5-1 Tension Arm Adjustment

### 5.2.2 Final Tension Adjustment

#### NOTE

To perform the following adjustment +5 Vdc is needed (+5 Vdc is available at C1 of the G159).

1. Mount and load a scratch tape.
2. Unplug the two quick disconnect terminals from the capstan motor terminals (not connector J9).
3. Ground one of the capstan motor terminals.
4. Connect an ammeter in series with +5 Vdc and the remaining capstan motor terminals. When connection is made, tape motion will begin. To reverse tape motion, swap the wires at the capstan motor terminals.
5. Adjust upper tension spring so that the current is equal for forward and reverse tape motion.

### 5.2.3 Tape Path Alignment Adjustment

Remove the upper and lower fixed guide reference edge capture washers, and press against the spring-loaded washers (Figures 5-2 and 5-3).

1. Perform maintenance test 11, with a work tape loaded that is known to be good. Ensure the tape has no edge damage.
2. Adjust gimbal screw 2 (Figure 5-2) until the tape rides in line with both the upper and lower fixed guide reference edge (Figure 5-3).
3. Perform maintenance test 50 and adjust gimbal screw 1 (Figure 5-2) until there is no visible difference in tape position on the capstan.
4. Continue maintenance test 50. Repeat adjustment of both gimbal screws 2 and 1 until the tape rides in line with the fixed guide reference edges and maintains a stable position on the capstan.
5. Ensure no tape puckering occurs at the roller guides and that the tape is not rubbing against the reels.

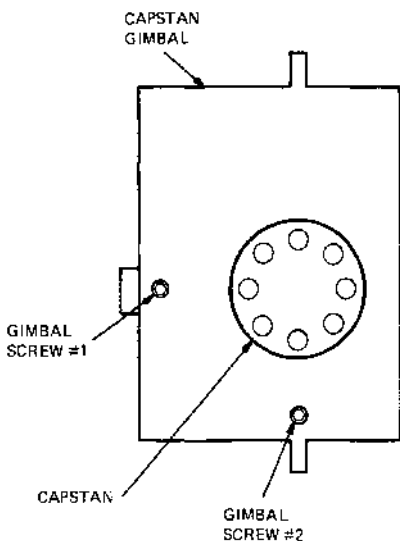
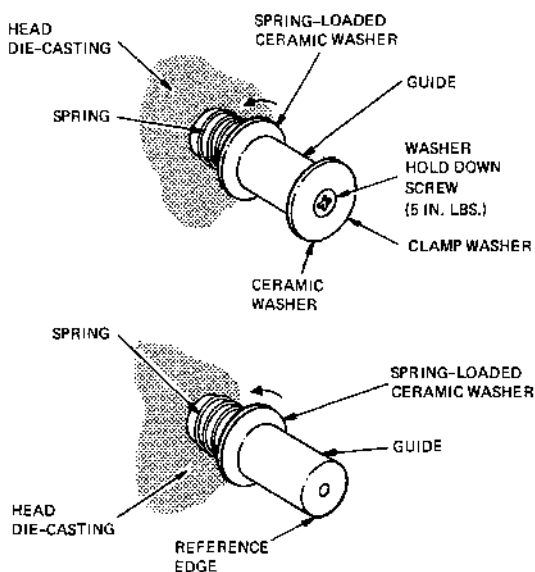

Figure 5-2 Capstan Gimbal Adjustment



MA-4002

Figure 5-3 Tape Path Guides

6. Stop the maintenance test. Carefully replace the capture washers, the beveled edge of the ceramic (brittle) washer facing the tape, and tighten to 5 in.lbs. Release the spring-loaded washers.

**NOTE**

**Use extreme care when tightening hold down screws on tape guides. The ceramic washers are brittle and could easily break.**

7. Perform maintenance test 50 again and check that the results have not changed; repeat all previous steps if necessary.

### 5.2.4 Tachometer Adjustment

Adjust the tachometer in maintenance mode with no tape mounted. Set up the oscilloscope as follows.

Channel 1	5 V/cm
Channel 2	5 V/cm
Vertical coupling	dc
Horizontal	100 $\mu$ s/cm
Trigger	Channel 1, normal, positive slope, ac coupled
Mode	Chop

1. Turn the null potentiometer on G159 (R26) CW four turns. The capstan will turn in a counterclockwise direction. Remove encoder cover.
2. Place probe 1 on chip E29 pin 3 and probe 2 on E29 pin 5 on the G159.
3. Adjust the two encoder potentiometers for 50 percent  $\pm$  5 percent duty cycle square waves on both traces.
4. Pin 5 should lead pin 3 by 90 percent  $\pm$  10 percent. Loosen the encoder mounting screws and adjust for this phase shift.
5. Reinstall encoder cover. Remove scope probes and adjust capstan null for 0 V.

### 5.2.5 Speed Test

Measure speed in the maintenance mode with tape loaded. Monitor Pin 3 E29 of G159 (tach phase 01). Set the oscilloscope as follows.

Channel 1	10 V/cm
Vertical coupling	dc
Horizontal	50 $\mu$ s/cm
Trigger	Channel 1, normal, positive slope

1. Run test 11 (forward) and verify there are no operator panel lights on. Otherwise, perform a tachometer adjustment.
2. Measure the period of the signal to be 250  $\mu$ s  $\pm$  3 percent. Jitter, measured from the same edge from which the scope is triggered, should be less than 5 percent (Figure 5-4).
3. Run test 12 (reverse) and verify the same measurement.

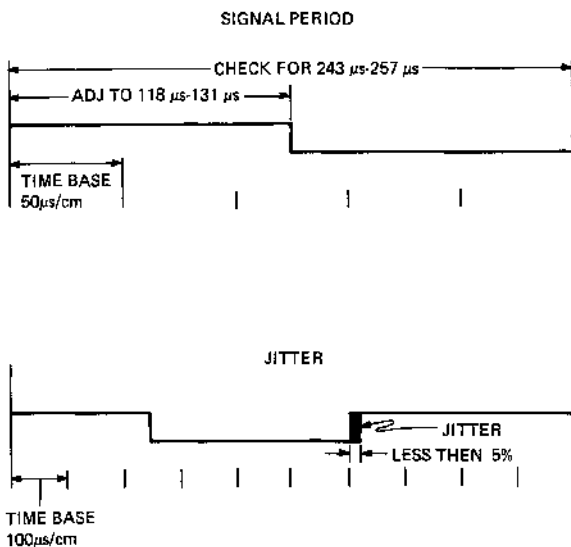

MA-9374

Figure 5-4 Capstan Speed Adjustment

### 5.2.6 Preamplifier Amplitude Adjustment

Perform maintenance test 54 with a *special test tape* loaded.

1. Remove the preamplifier board shield and attach a scope probe to TP0 (Figure 5-5).
2. Adjust the bit weight zero gain potentiometer (Figure 5-5) for  $10 \text{ V}_{p-p} \pm 0.25 \text{ V}$  in the preamble portion of the analog signal on the scope (Figure 5-6).
3. Move the scope probe to the remaining test points and adjust the corresponding gain potentiometers, including test point TPP (Figure 5-6).
4. Ensure the data portion of signals TP0 through TP7 does not exceed  $16.7 \text{ V}_{p-p}$  (Figure 5-6).
5. Stop the maintenance test, remove the scope probe, replace and secure the board shield, and tighten to 6 in. lbs.

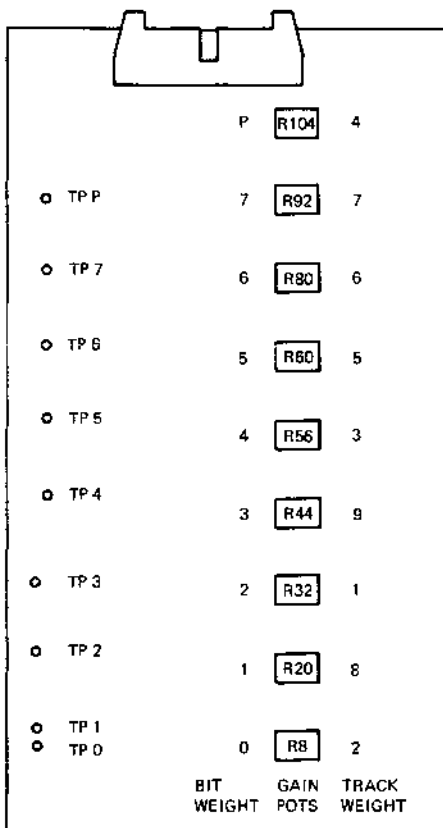

MA-3984

Figure 5-5 Read Preamp Locator



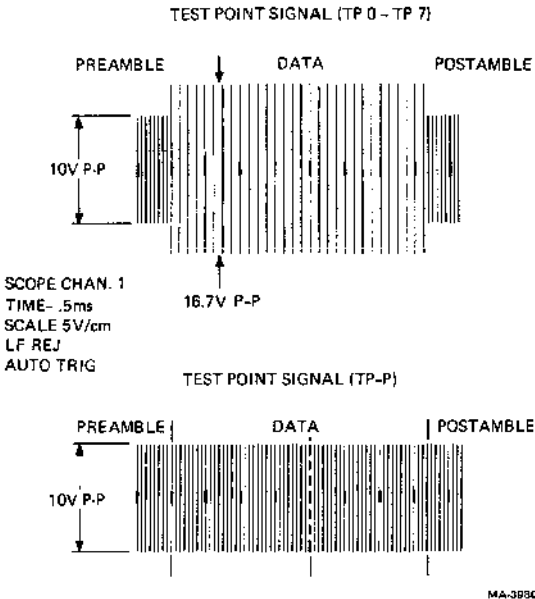

Figure 5-6 Read Preamp Adjustment

### 5.2.7 Threshold Adjustment

Measure in the maintenance mode with a *special test tape* loaded. Set the oscilloscope as follows.

Channel 1	5 V/cm
Channel 2	1 V/cm
Vertical coupling	dc
Horizontal	2 ms/cm
Trigger	Channel 1, normal, positive slope
Mode	Alternate

Channel 1	Monitor RD0 of the maintenance panel.
Channel 2	Monitor Pin A3A1 of the backplane.

1. Run test 54 and verify Pin A3A1 is  $0.9 \text{ V} \pm 0.1 \text{ V}$  during the data portion of the analog signal (Figure 5-7).
2. Adjust the top potentiometer (R46) of M8923 if needed.

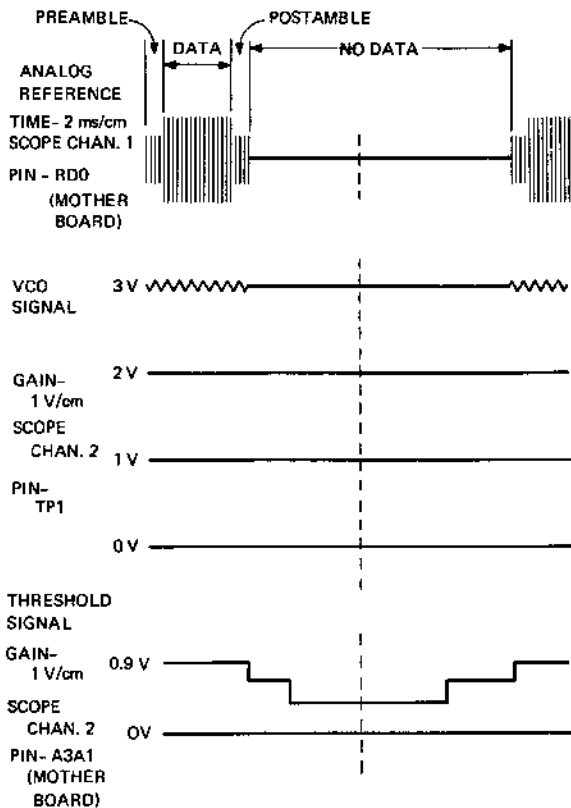

MA-3982

Figure 5-7 Threshold and VCO Adjustment

### 5.2.8 VCO Adjustment

Measure VCO in the maintenance mode with a *special test tape* loaded. Set the oscilloscope as shown in Paragraph 5.2.7.

- |           |                                       |
|-----------|---------------------------------------|
| Channel 1 | Monitor RDO on the maintenance panel. |
| Channel 2 | Monitor VCO TP1 on M8922.             |

1. Run test 54. Adjust the potentiometer on M8922 for minimal level shift (dc) between data and no data portions of the signal on channel 2 (Figure 5-7).

**5.2.9 Skew Meter Calibration**

To calibrate the skew meter run test 31 and adjust the lower potentiometer (R49) on the M8923 until operator panel indicators 0 and 1 stay off.

**NOTE**

**There is considerable lag between adjustment of the potentiometer and an updated display.**

**5.2.10 Head Skew Adjustment**

Measure head skew in the maintenance mode with a master skew tape loaded. Set the oscilloscope as follows.

Channel 1	1 V/cm
Vertical coupling	dc
Horizontal	0.5 ms/cm
Trigger	Channel 1, normal, positive slope

Channel 1      Skew out testpoint on maintenance panel.

1. Run test 51 (forward). Adjust the head azimuth (Figure 5-8) screw for minimum output. It must be at or near 0V (2.5 V max) in the forward direction.
2. Run test 52. Verify that the reverse skew signal is at or near 0 V (3.0 V max).
3. Run test 50. Verify that both the EOT and BOT indicators are off. If not, adjust head azimuth screw until indicators are off.

**5.2.11 Tension Arm Transducer Coarse Adjustment****NOTE**

To perform the following adjustment, make two small loops from tape or string. Place one loop between the upper tension arm roller guide and the buffer arm assembly. Place the other loop between the lower tension arm roller guide and the roller tape guide. (See Figure 1-5 for locations.) Each loop should be long enough to hold each tension arm at 1/2 to 2/3 its travel.

1. Switch to maintenance mode and run test 6.
2. Loosen the tension arm transducer securing screws.
3. Adjust the upper transducer for no movement of the supply reel. Tighten the securing screw.

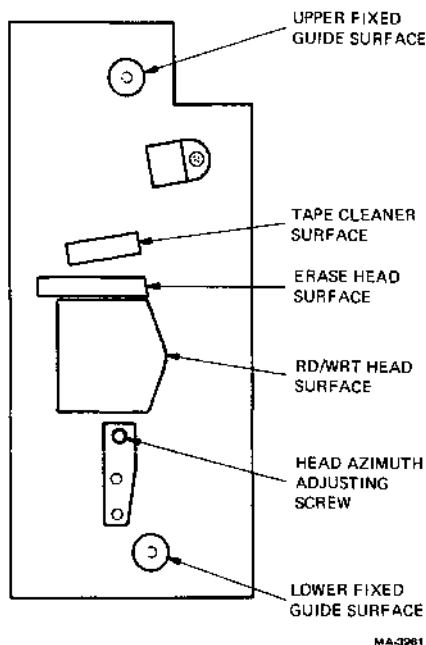

Figure 5-8 Head Skew Adjustment

4. Adjust the lower transducer for no movement of the takeup reel. Tighten the securing screw.
5. Stop test 6. Remove the loops and perform the fine adjustment (below).

### 5.2.12 Tension Arm Transducer Fine Adjustment

1. Load a scratch tape.
2. In maintenance mode, run test 50.
3. Observe the position of the tension arms while tape is moving. There should be a clearance of  $1/2$  to 1 inch between the tension arms and the limit switches at both ends of their travel. If an arm is close at one limit and far away at the other limit, a fine adjustment is necessary.

4. Adjust the associated transducer until the clearances at both ends of travel of the tension arm are equal.

**NOTE**

**Be careful adjusting transducers while tape is moving, as too large an adjustment change can cause the limits to be exceeded, dropping tape tension.**

5. Repeat step 3.
6. Tighten securing screws to 24 in.lbs.

# A REGISTER SUMMARY

REGISTER	BITS															
	15	14	13	12	11	10	09	08	07	06	05	04	03	02	01	00
TSRA (R/O)	A15	A14	A13	A12	A11	A10	A09	A08	A07	A06	A05	A04	A03	A02	A01	A00
TSUB (W/O)	P15	P14	P13	P12	P11	P10	P09	P08	P07	P06	P05	P04	P03	P02	P17	P18
TSSR	SC	UPE	SPL	RMH	NXM	NBA	A17	A16	SSP	OFL	FC1	FC0	TC2	TC1	TC0	
	S	4/5	7/F/2	S	4/5	S	S	S	S	S	?	?	S	S	S	
RBPCR	C15	C14	C13	C12	C11	C10	C09	C08	C07	C06	C05	C04	C03	C02	C01	C00
XST0	TMR	RLS	LET	RLI	WLE	NLF	ILC	ILA	MDT	ONL	IE	VCK	PED	WLK	BOT	EOT
	S/2	2	2	2	3/6	3	3	3	S	S/1/3	S	S/3	S	S/3/6	S/2/3	S/2
XST1	DLT		CDR	CRS	TIG	DBF	SCK		IPR	SYN	IPD	IED	POS	P11L	UNC	MIE
	4		S	4	4	4	4		S/4	4	S/4	4	S/4	4	4	4
XST2	OPM	SIP	BPE	CAF		WCF		DTP	DT7	DT6	DT5	DT4	DT3	DT2	DT1	DT0
	S	7F2	7F2	?		?		S	S	S	S	S	S	S	S	S
XST3	MICRODIAGNOSTIC ERROR CODE								LMX	DPI	HEV	CRF	OCK	NOI	LXS	RIB
	7	7	7	7	7	7	7	7	?	6	6	S	?	S/6	6	6

**Termination Class Codes:**

- 0 - Normal Termination
- 1 - Attention Condition
- 2 - Tape Status Alert
- 3 - Function Reject
- 4 - Recoverable Error - Tape Position = One record slow tape from start of function
- 5 - Recoverable Error - Tape not removed
- 6 - Unrecoverable Error - Tape position lost
- 7 - Fatal Controller Error

**Fatal Class (FC) Codes (in TSSR):**

- 0 - Internal diagnostic failure (displayed in OP panel)
- 1 - IO sequencer CROM parity error or main CROM parity error (if PC = 1750 then error is I/O CROM parity).
- 2 - Microprocessor CROM parity error or other fatal error (Program counter display or SILQ parity in ext. status)
- 3 - Loss of AC power has been detected.

**Non-termination Class Code:**

S = Status

XA 2848A

Figure A-1 TS11 Register Summary

## BUS ADDRESS REGISTER (TSBA)

UNIBUS ADDRESS + 0 BUS ADDRESS - (READ ONLY) - TSBA

15	14	13	12	11	10	09	08	07	06	05	04	03	02	01	00
A15	A14	A13	A12	A11	A10	A09	A08	A07	A06	A05	A04	A03	A02	A01	A00
S	S	S	S	S	S	S	S	S	S	S	S	S	S	S	S

BIT	NAME	DEFINITION
15	A15	100000 BUS ADDRESS BIT 15
14	A14	40000 BUS ADDRESS BIT 14
13	A13	20000 BUS ADDRESS BIT 13
12	A12	10000 BUS ADDRESS BIT 12
11	A11	4000 BUS ADDRESS BIT 11
10	A10	2000 BUS ADDRESS BIT 10
09	A09	1000 BUS ADDRESS BIT 09
08	A08	400 BUS ADDRESS BIT 08
07	A07	200 BUS ADDRESS BIT 07
06	A06	100 BUS ADDRESS BIT 06
05	A05	40 BUS ADDRESS BIT 05
04	A04	20 BUS ADDRESS BIT 04
03	A03	10 BUS ADDRESS BIT 03
02	A02	4 BUS ADDRESS BIT 02
01	A01	2 BUS ADDRESS BIT 01
00	A00	1 BUS ADDRESS BIT 00

MA-4006

Figure A-2 Bus Address Register

## DATA BUFFER REGISTER (TSDB)

UNIBUS ADDRESS - 0 - DATA BUFFER - (WRITE ONLY) - TSDB

15	14	13	12	11	10	09	08	07	06	05	04	03	02	01	00
P15	P14	P13	P12	P11	P10	P09	P08	P07	P06	P05	P04	P03	P02	P17	P16

BIT	NAME	DEFINITION
15	P15	100000 COMMAND POINTER BIT 15
14	P14	40000 COMMAND POINTER BIT 14
13	P13	20000 COMMAND POINTER BIT 13
12	P12	10000 COMMAND POINTER BIT 12
11	P11	4000 COMMAND POINTER BIT 11
10	P10	2000 COMMAND POINTER BIT 10
09	P09	1000 COMMAND POINTER BIT 09
08	P08	400 COMMAND POINTER BIT 08
07	P07	200 COMMAND POINTER BIT 07
06	P06	100 COMMAND POINTER BIT 06
05	P05	40 COMMAND POINTER BIT 05
04	P04	20 COMMAND POINTER BIT 04
03	P03	10 COMMAND POINTER BIT 03
02	P02	4 COMMAND POINTER BIT 02
01	P17	2 COMMAND POINTER BIT 17
00	P16	1 COMMAND POINTER BIT 16

MA-4006

Figure A-3 Data Buffer Register

STATUS REGISTER (TSSR)

(UNIBUS ADDRESS + 2 - READ ONLY)

15	14	13	12	11	10	09	08	07	06	05	04	03	02	01	00
SC	UPE	SPE	RMR	NXM	NEA	A17	A16	SSR	OFL	FC1	FC0	TC2	TC1	TC0	
S	4,5	FC2 7	S	4,5	S	S	S	S	S, 1 .3	7	7	S	S	S	

SC	10000	SPECIAL CONDITION
UPE	40000	UNIBUS PARITY ERROR
SPE	20000	SERIAL BUS PARITY ERROR
RMR	10000	REGISTER MODIFICATION REFUSED
NXM	4000	NON-EXISTENT MEMORY
NBA	2000	NEED BUFFER ADDRESS
A17	1000	UNIBUS ADDRESS BIT 17
A16	400	UNIBUS ADDRESS BIT 16
SSR	200	SUBSYSTEM READY
OFL	100	OFF-LINE
FC1	40	FATAL TERMINATION CLASS 01
FC0	20	FATAL TERMINATION CLASS 00
TC2	10	TERMINATION CLASS BIT 02
TC1	4	TERMINATION CLASS BIT 01
TC0	2	TERMINATION CLASS BIT 00
NA	1	NA

MA-4017

Figure A-4 STATUS Register

RESIDUAL FRAME COUNT REGISTER  
RBPCR



BIT NAME



THIS WORD WILL CONTAIN THE OCTAL COUNT OF RESIDUAL BYTES/RECORDS/ TAPE MARKS FOR THE READ. SPACE RECORDS, AND SKIP TAPE MARK COMMANDS. THE CONTENTS ARE MEANINGLESS FOR ALL OTHER COMMANDS.

MA-5349

Figure A-5 Residual Frame Count Register



## EXTENDED STATUS REGISTER 0 (XSTAT 0)

15	14	13	12	11	10	09	08	07	06	05	04	03	02	01	00
TMK	RLS	LET	RLL	WLE	NEF	ILC	ILA	MOT	ONL	IE	VCK	PED	WLK	BOT	EOT
S,2	2	2	2	3,6	3	3	3	5	S,1 ,3	S	S,3	S	S,3	S,3	S,2

TMK	10000	TAPE MARK (READ-SPACE/WRITE-SKIP/OTHER)
RLS	4000	RECORD LENGTH SHORT
LET	2000	LOGICAL END OF TAPE
RLL	1000	RECORD LENGTH LONG
WLE	400	WRITE LOCK ERROR
NEF	200	NON-EXECUTABLE FUNCTION
ILC	100	ILLEGAL COMMAND
ILA	40	ILLEGAL ADDRESS
MOT	20	CAPSTAN MOVING
ONL	10	ON-LINE
IE	4	INTERRUPT ENABLE
VCK	2	VOLUME CHECK
PED	1	PE DRIVE
WLK	4	WRITE LOCK
BOT	2	BEGINNING OF TAPE
EOT	1	END OF TAPE

MA-4011

Figure A-6 Extended STATUS Register 0

## EXTENDED STATUS REGISTER 1 (XSTAT 1)

15	14	13	12	11	10	09	08	07	06	05	04	03	02	01	00
DLT		COR	CRS	TIG	DBF	SCK		IPR	SYN	IPO	IED	POS	POL	UNC	MTE
4		S,4	4	4	4	4		S,4	4	S,4	4	S,4	4	4	4

DLT	10000	DATA LATE ERROR
NA	4000	NA
COR	2000	CORRECTABLE DATA
CRS	1000	CREASE DETECTED
TIG	400	TRASH IN GAP
DBF	200	DESKEW BUFFER FAILURE
SCK	100	SPEED CHECK
NA	40	NA
IPR	20	INVALID PREAMBLE
SYN	10	SYNC FAILURE
IPO	4	INVALID POSTAMBLE
IED	2	INVALID END DATA
POS	1	POSTAMBLE SHORT
POL	4	POSTAMBLE LONG
UNC	2	UNCORRECTABLE DATA *
MTE	1	MULTITRACK ERROR

\*UNCORRECTABLE DATA WILL BE FLAGGED ON A WRITE ERROR.

MA-4010

Figure A-7 Extended STATUS Register 1

## EXTENDED STATUS REGISTER 2 (XSTAT2)

15	14	13	12	11	10	09	08	07	06	05	04	03	02	01	00
OPM	SIP	BPE	CAF		WCF		DTP	DT7	DT6	DT5	DT4	DT3	DT2	DT1	DT0
S	FC2 7	FC2 7	7		7		S	S	S	S	S	S	S	S	S

OPM	100000	OPERATION IN PROGRESS (TAPE MOVING)
SIP	40000	I/O SILO PARITY ERROR
BPE	20000	SERIAL BUS PARITY ERROR
CAF	10000	CAPSTAN ACCELERATION FAILURE
NA	4000	NA
WCF	2000	WRITE CLOCK FAILURE
NA	1000	NA
DTP	400	DEAD TRACK INDICATORS FOR TRACKS
DT7	200	
DT6	100	
DT5	40	
DT4	20	
DT3	10	
DT2	4	
DT1	2	
DT0	1	DEAD TRACK INDICATORS FOR TRACKS

MA-4013

Figure A-8 Extended STATUS Register 2

## EXTENDED STATUS REGISTER 3 (XSTAT3)

15	14	13	12	11	10	09	08	07	06	05	04	03	02	01	00
MICRODIAGNOSTIC ERROR CODE							LMX	OPI	REV	CRF	DCK	NOI	LXS	RIB	
7	7	7	7	7	7	7	7	6	6	S	7	S,6	6	S	2

NA	100000	NA
NA	40000	NA
NA	20000	NA
NA	10000	NA
NA	4000	NA
NA	2000	NA
NA	1000	NA
NA	400	NA
LMX	200	LIMIT EXCEEDED
OPI	100	OPERATION INCOMPLETE
REV	40	TAPE MOTION REVERSE; IF MULTIPLE RETRY AT LEAST 1 WAS REVERSE
CRF	20	CAPSTAN RESPONSE FAILURE
DCK	10	DENSITY CHECK
NOI	4	NOISE RECORD
LXS	2	LIMIT EXCEEDED STATICALLY (LATCHED)
RIB	1	REVERSE INTO BOT

MA-4014

Figure A-9 Extended STATUS Register 3



# B TROUBLESHOOTING FLOWCHART

