

THIS DRAWING AND SPECIFICATIONS HEREIN ARE THE PROPERTY OF DIGITAL EQUIPMENT CORPORATION AND SHALL NOT BE REPRODUCED OR COPIED OR USED IN WHOLE OR IN PART AS THE BASIS FOR THE MANUFACTURE OR SALE OF ITEMS WITHOUT WRITTEN PERMISSION.
COPYRIGHT © 1978, DIGITAL EQUIPMENT CORPORATION

NOTES:
1. CAUTION: ANY CHANGE TO THIS BACKPLANE ASSY WILL EFFECT THE 1144-T BACK PLANE ASSY (TEST EQUIPMENT DWG WO* E-AD-9505537-0-0 AND MUST BE CHANGED ACCORDINGLY.

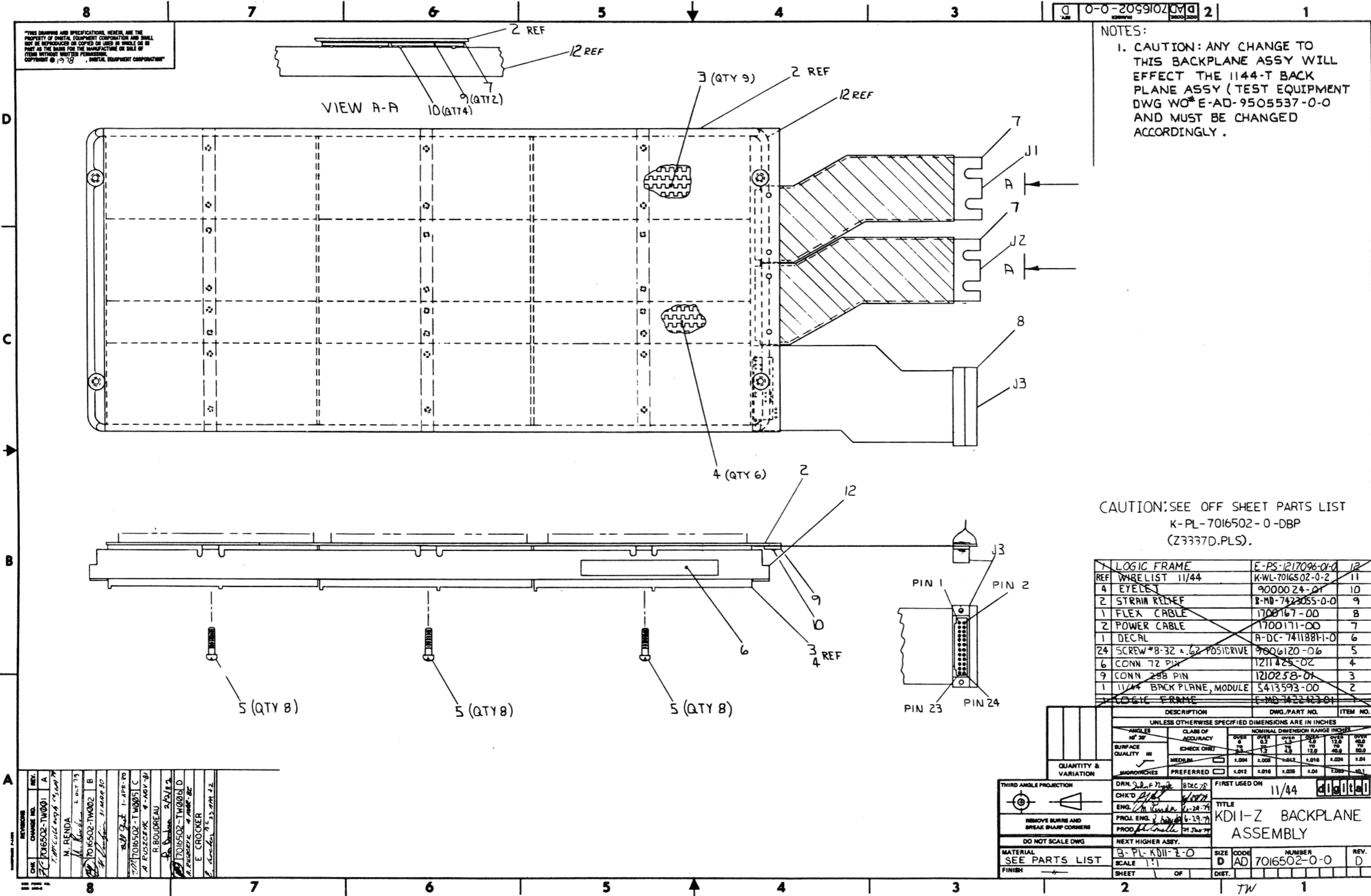

CAUTION: SEE OFF SHEET PARTS LIST K-PL-7016502-0-DBP (Z3337D.PLS).

REF	DESCRIPTION	DWG./PART NO.	ITEM NO.
7	LOGIC FRAME	E-PS-1217096-01-0	12
REF	WIRELIST 11/44	K-WL-7016502-0-2	11
4	EYELET	9000024-01	10
2	STRAIN RELIEF	8-MD-7423055-0-0	9
1	FLEX CABLE	1700167-00	8
2	POWER CABLE	1700171-00	7
1	DECAL	A-DC-7411881-0	6
24	SCREW #8-32 x .62 POSIDRIVE	9006120-06	5
6	CONN 72 PIN	1211425-02	4
9	CONN 288 PIN	1210258-01	3
1	1144 BACK PLANE, MODULE	5413593-00	2
1	LOGIC FRAME	E-MD-7422423-01	1

UNLESS OTHERWISE SPECIFIED DIMENSIONS ARE IN INCHES	
ANGLE 30°	CLASS OF ACCURACY
SURFACE QUALITY	FINISH
QUANTITY & VARIATION	FINISH

THIRD ANGLE PROJECTION

REMOVE BURRS AND BREAK SHARP CORNERS

DO NOT SCALE DWG

MATERIAL SEE PARTS LIST

FINISH

DRN. *[Signature]* 8 DEC 78

CHK'D *[Signature]* 1/1/79

ENG. *[Signature]* 1/1/79

PROJ. ENG. *[Signature]* 1/1/79

PROOF *[Signature]* 1/1/79

FIRST USED ON 11/44

TITLE KD11-Z BACKPLANE ASSEMBLY

SIZE D AD

CODE AD

NUMBER 7016502-0-0

REV. D

REV.	DATE	BY	APP.	DESCRIPTION
A	1-APR-70	M. RENDA		1-APR-70
B	2-OCT-73	M. RENDA		2-OCT-73
C	4-NOV-81	A. RUSZCZYK		4-NOV-81
D	2-22-87	R. BOUDREAU		2-22-87
E	4-NOV-87	E. CROCKER		4-NOV-87

K-PL-7016502-0-0-D

A

THIS DRAWING AND SPECIFICATIONS HEREIN ARE THE PROPERTY OF DIGITAL EQUIPMENT CORPORATION AND SHALL NOT BE REPRODUCED OR COPIED OR USED IN WHOLE OR IN PART AS THE BASIS FOR THE MANUFACTURE OR SALE OF ITEMS WITHOUT WRITTEN PERMISSION
 COPYRIGHT © 1979 DIGITAL EQUIPMENT CORPORATION

REV. A
 9-Z-11DK
 0800
 0800
 3215

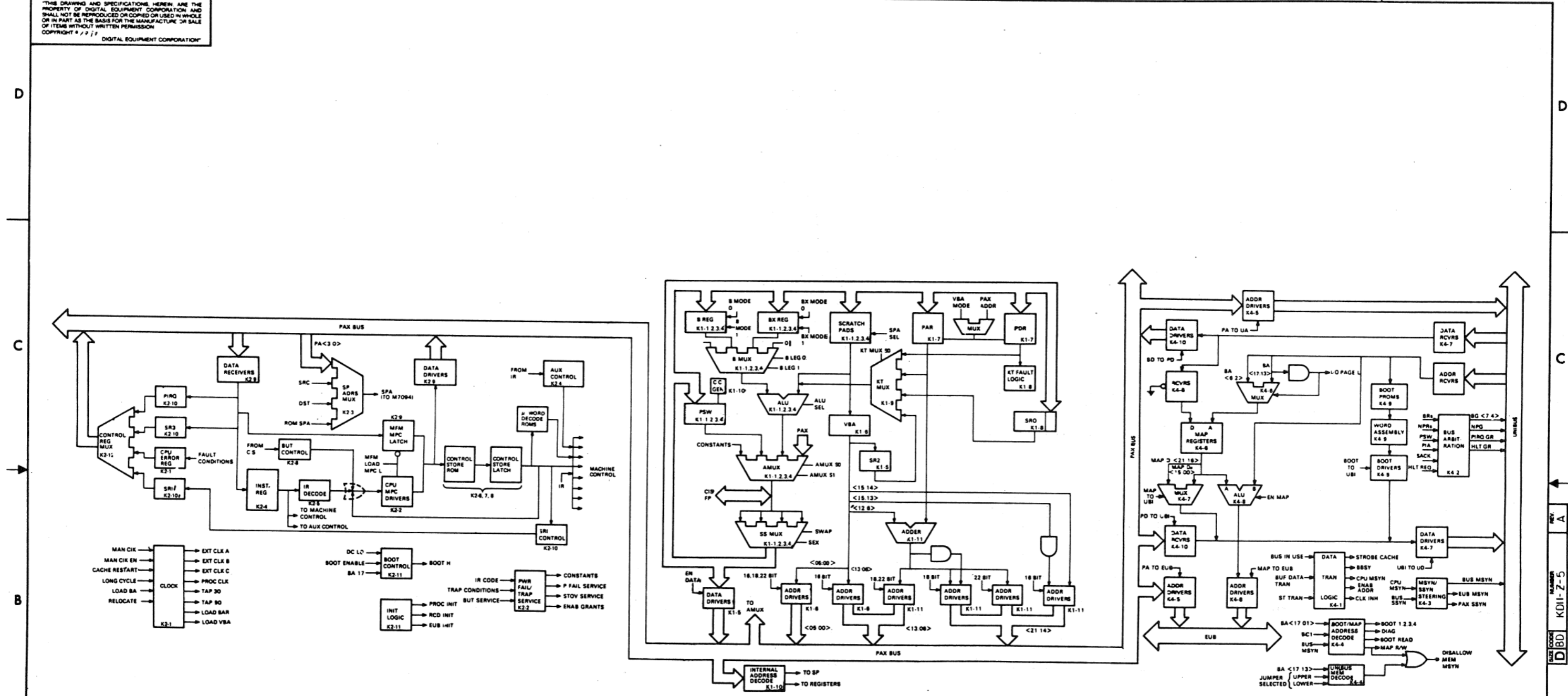

REVISION HISTORY

DATE	ECO NUMBER	REV.
7-81	KDI1-Z-TRG01	A
	(ORIGINATED)	

DRW. S. STEARN	DATE 17-APR-80	TITLE	digital
CHG'D B. GIST	DATE 17-APR-80	KDI1-Z BLOCK DIAGRAM	
DES. ENG. B. GIST	DATE 17-APR-80	DOCUMENT NUMBER	
RESP. ENG. B. GIST	DATE 17-APR-80	KDI1-Z-5	
MFG. ENG. B. GIST	DATE 17-APR-80	SCALE	NONE
NEXT HIGHER DOC. B-DD-KDI1-Z-0		REV.	A

T4-4886

NOTES:
1. REFER TO PAGE 27 FOR CONTROL WORD FIELD DEFINITIONS.

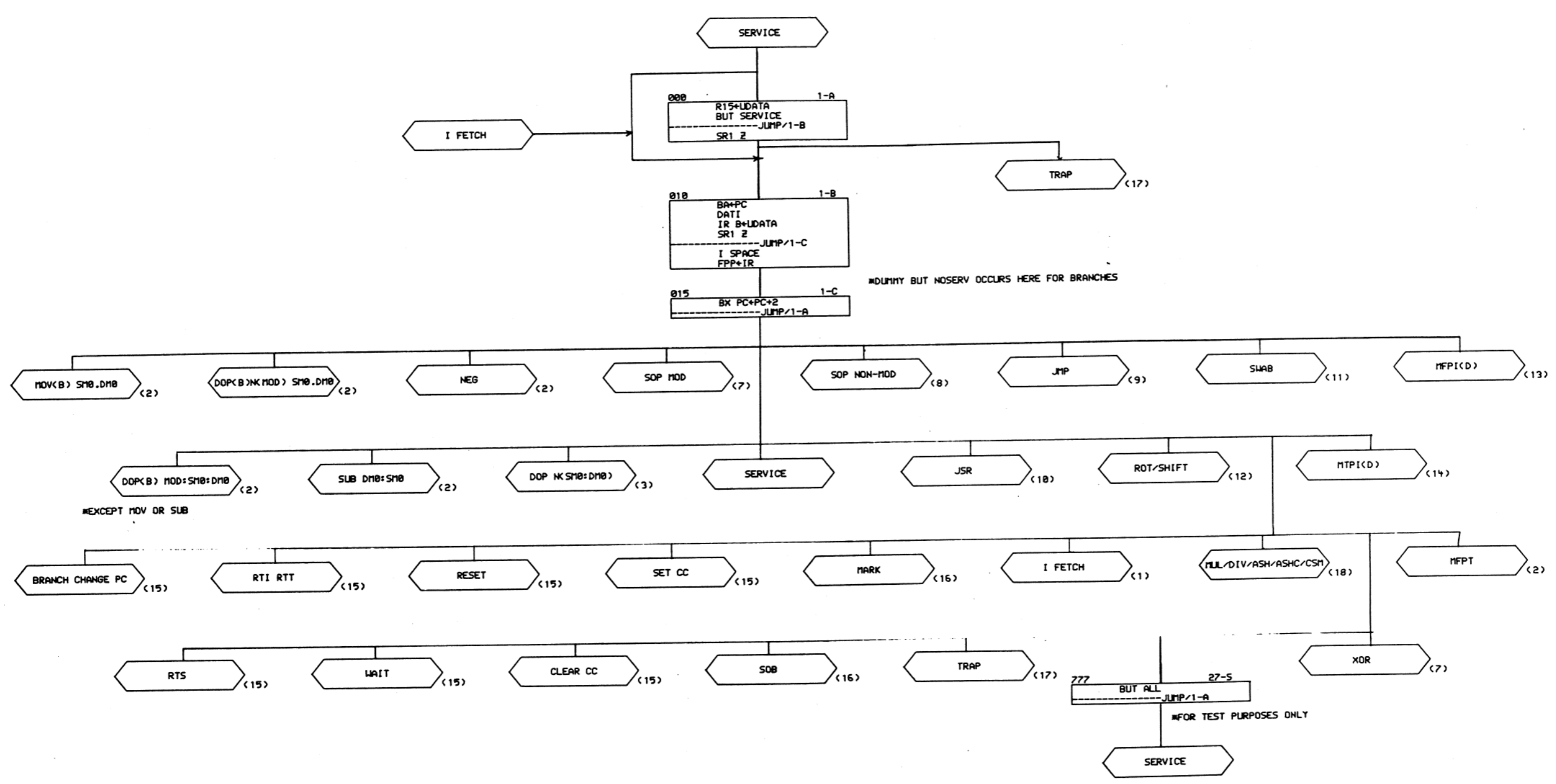

REVISION HISTORY
CHK. NO. NUMBER REV.
741 1011-2-1001 B
E. GUYLER / W. ALPERLEE

DRN. <i>John J. ...</i>	DATE <i>10-28-79</i>	ENG. <i>John J. ...</i>	DATE <i>27 JUN 79</i>	TITLE: KD11-2 FLOW DIAGRAMS
CHK'D. <i>John J. ...</i>	DATE <i>27 JUN 79</i>	BOARD LOCATION: SHEET 1 OF 27	SIZE CODE NUMBER	REV. 5
DSK:PAGE1.T2PC160.54171119-JUN-79 12:36 NEXT HIGHER ASSEMBLY: B-DD-KD11-2-Z				D FD KD11-2-2
FIRST USED ON OPTION/MODEL: 11/44				

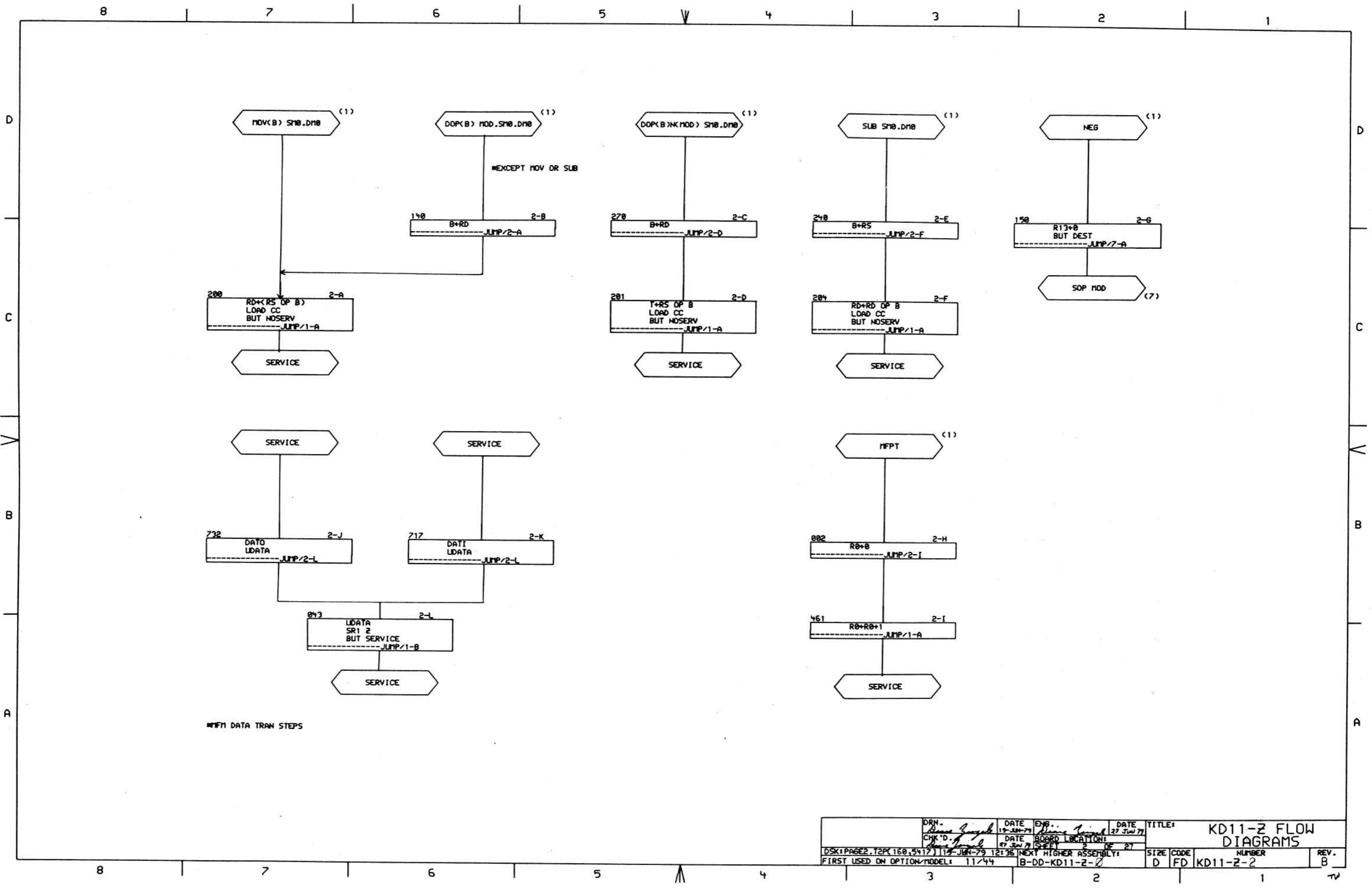

DRN. <i>James Lynch</i>	DATE 19 JUN 79	ENG. <i>James Lynch</i>	DATE 27 JUN 79	TITLE: KD11-Z FLOW DIAGRAMS
CHK'D. <i>James Lynch</i>	DATE 27 JUN 79	BOARD LOCATION: SHEET 2 OF 27	SIZE CODE D FD	NUMBER KD11-Z-2
FIRST USED ON OPTION/MODEL: 11/44	11/44	NEXT HIGHER ASSEMBLY: B-DD-KD11-Z-0	REV. B	

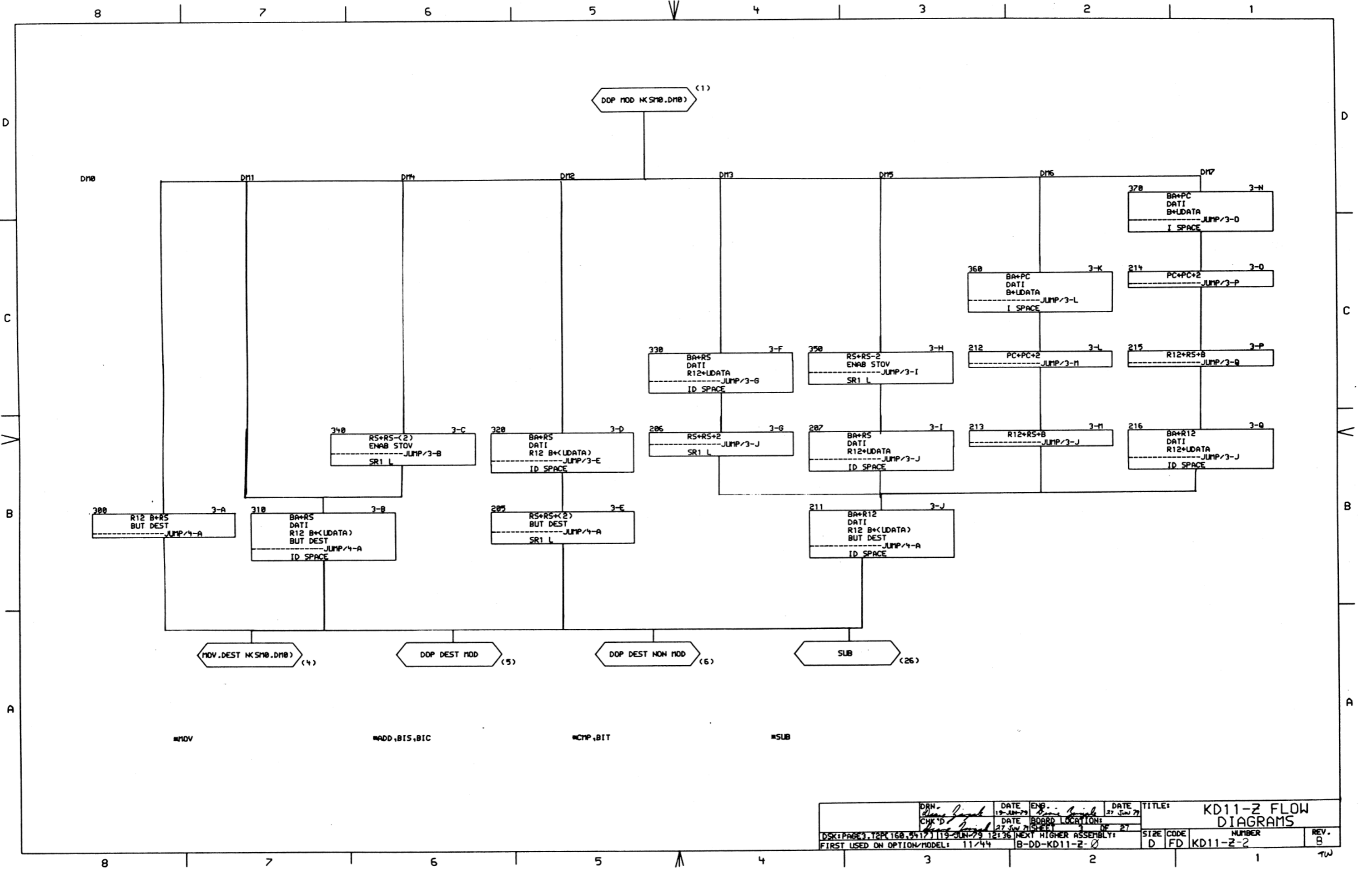

DRN: <i>David B. Smith</i>	DATE: 19-JUN-79	ENR: <i>David B. Smith</i>	DATE: 27 JUN 79	TITLE: KD11-Z FLOW DIAGRAMS
CHK'D: <i>David B. Smith</i>	DATE: 27 JUN 79	DRN: <i>David B. Smith</i>	DATE: 27 JUN 79	REV: B
DSK: PAGE 3, 12PL 160, 5417, 119-JUN-79, 12:36		NEXT HIGHER ASSEMBLY: B-DD-KD11-Z-0		SIZE: D
FIRST USED ON OPTION/MODEL: 11/44		NUMBER: KD11-Z-2		REV: B

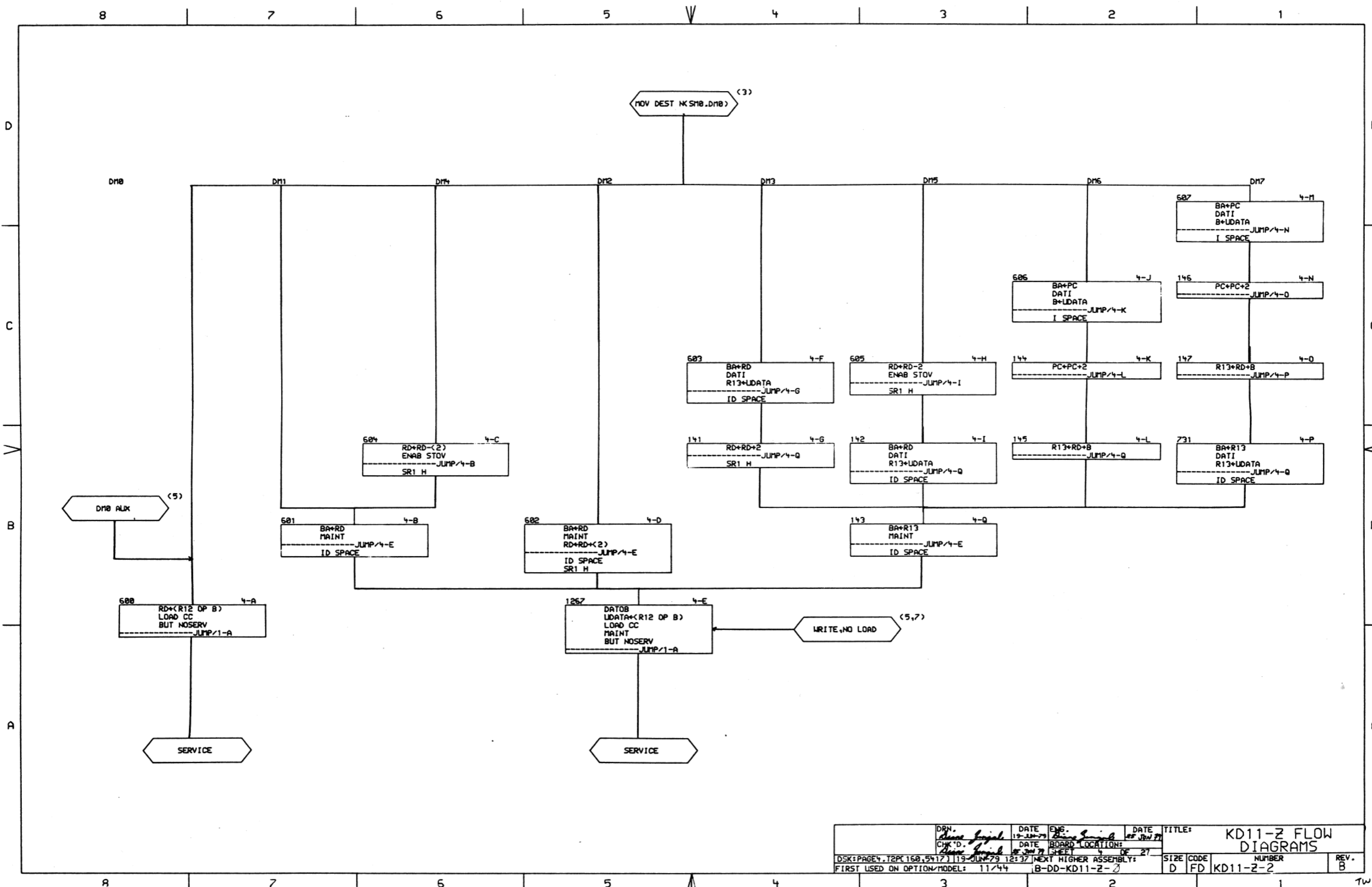

DRN. <i>Steve Fogel</i>	DATE 19 JUN 79	ENG. <i>Steve Fogel</i>	DATE 25 JUN 79	TITLE: KD11-Z FLOW DIAGRAMS
CHK'D. <i>Steve Fogel</i>	DATE 19 JUN 79	BOARD LOCATION: 4 OF 27	SHEET 4 OF 27	SIZE CODE D FD
DSK: PAGE 4, T2PC 160, 5412119 JUN 79 12:37		NEXT HIGHER ASSEMBLY: B-DD-KD11-Z-2		NUMBER KD11-Z-2
FIRST USED ON OPTION/MODEL: 11/44			REV. B	

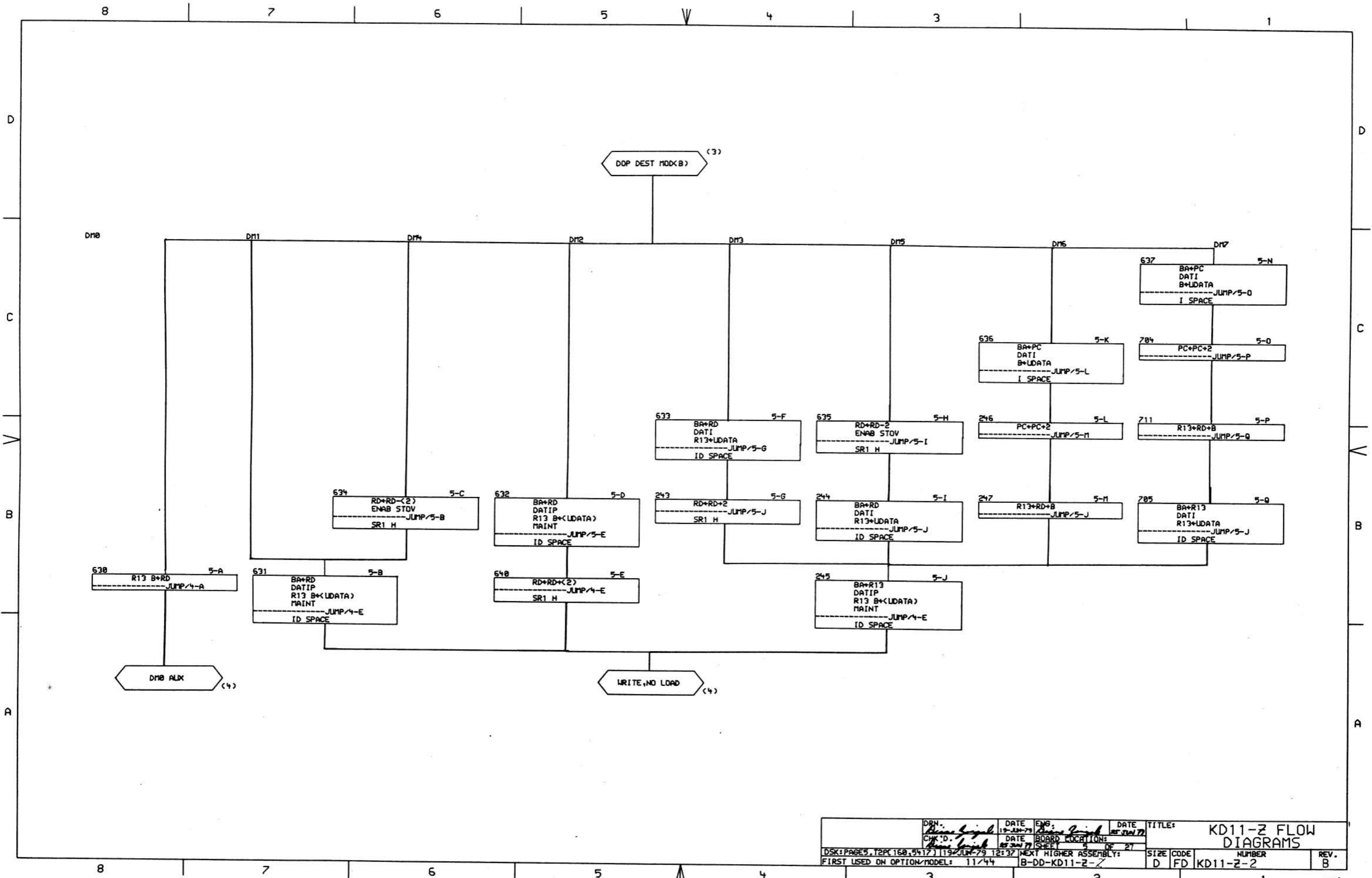

DRN.	DATE	ENG.	DATE	TITLE:
CHK'D.	DATE	BOARD LOCATION:	DATE	KD11-Z FLOW
		SHEET	OF	DIAGRAMS
DSK: PAGES, 12PK 160, 5417, 119, JUN-79 12:37				SIZE CODE
FIRST USED ON OPTION/MODEL: 11/44				D FD
NEXT HIGHER ASSEMBLY: B-DD-KD11-Z-Z				NUMBER
				KD11-Z-2
				REV.
				B

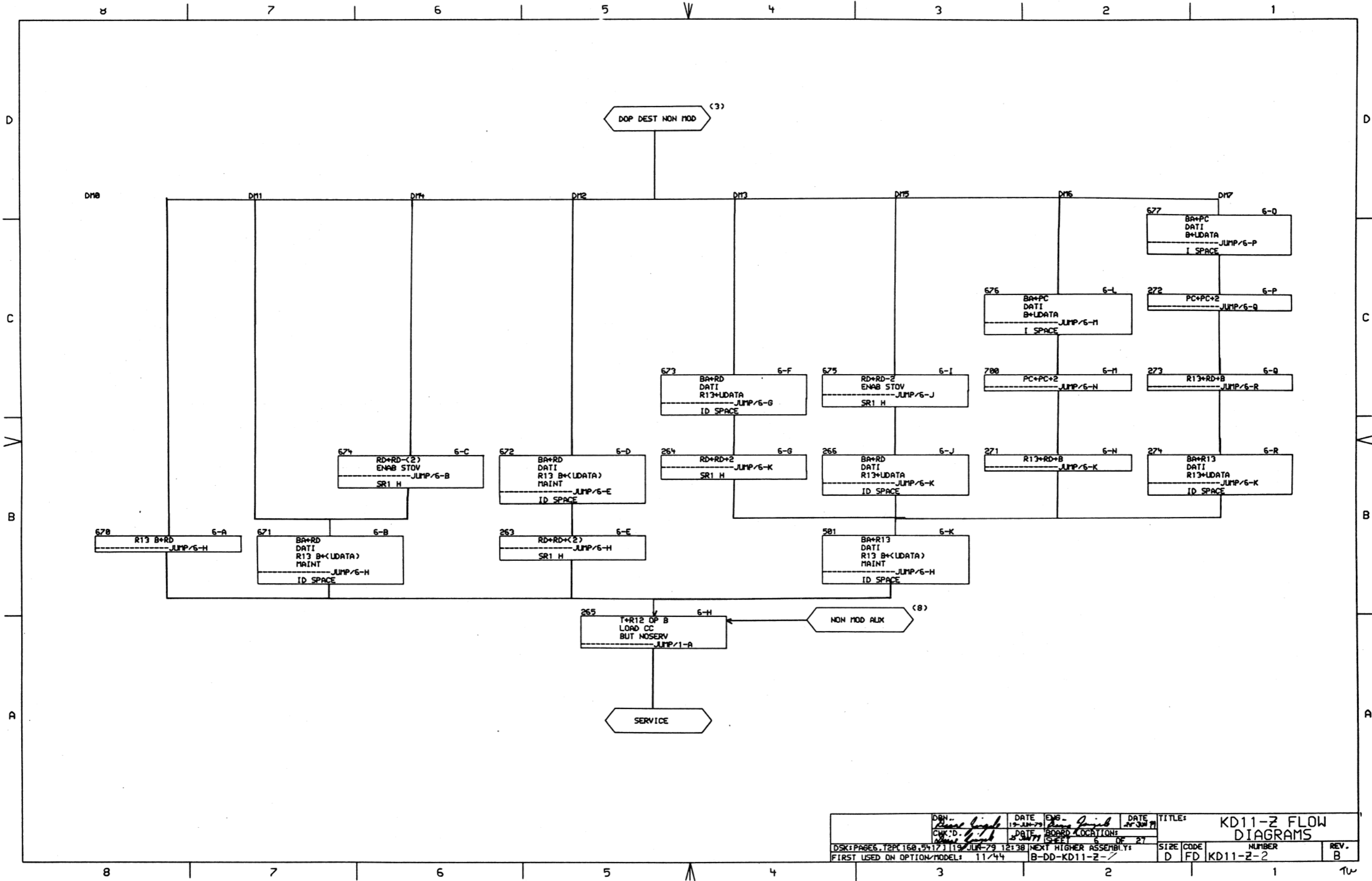

DRN - <i>James Smith</i>	DATE 15 JUN 79	ENG - <i>James Smith</i>	DATE 20 JUN 79	TITLE: KD11-Z FLOW DIAGRAMS
CHK'D - <i>James Smith</i>	DATE 20 JUN 79	DRIF	BOARD LOCATION: SHEET 6 OF 27	SIZE CODE NUMBER REV. D FD KD11-Z-2 B
DSK: PAGE 6, TPC 160, 5417, 119, JUN 79 12:38				NEXT HIGHER ASSEMBLY: B-DD-KD11-Z-2
FIRST USED ON OPTION/MODEL: 11/44				

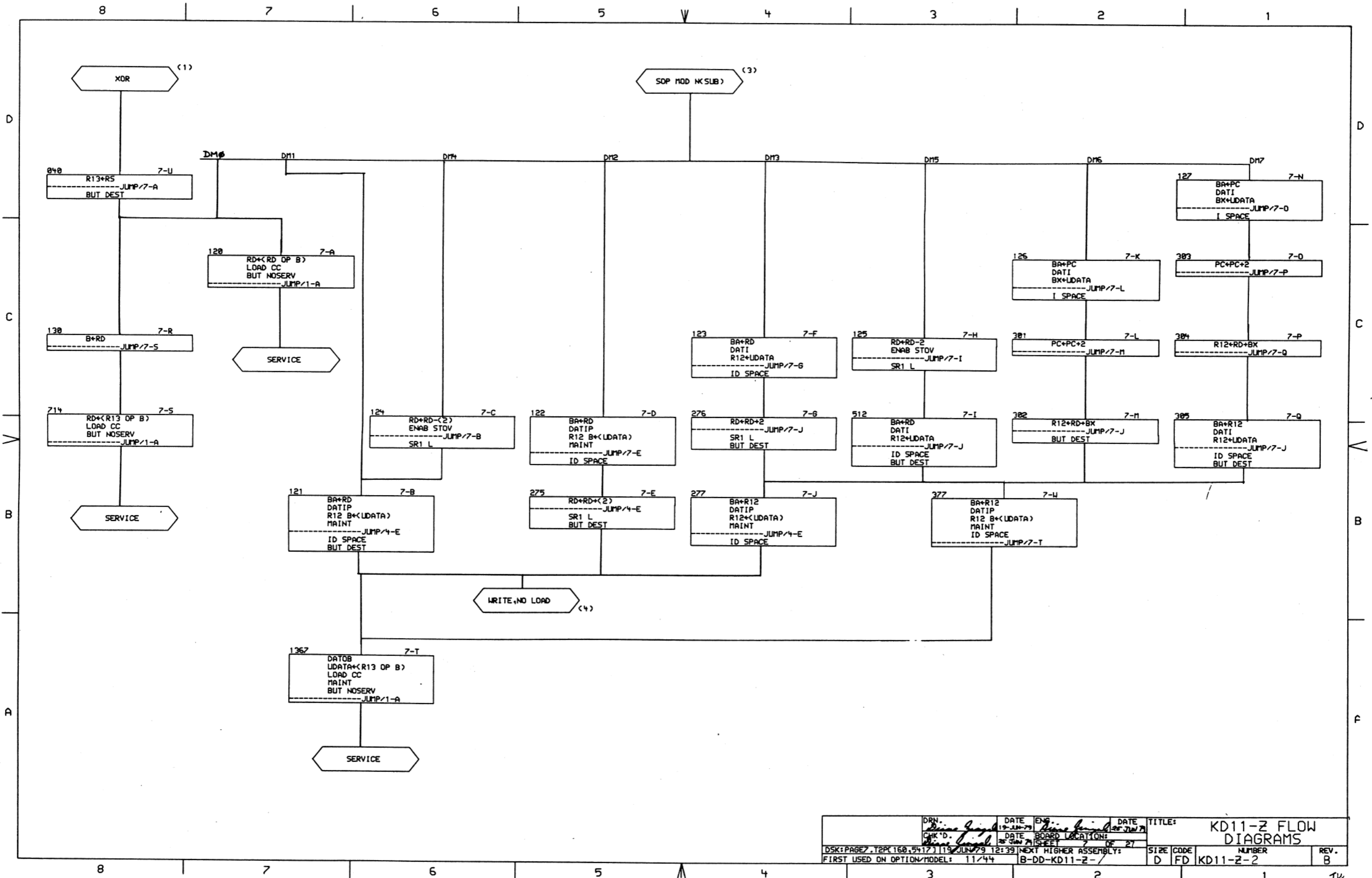

DRN.	DATE	ENG.	DATE	TITLE:
CHK'D.	DATE	BOARD LOCATION:		KD11-Z FLOW DIAGRAMS
			OF 27	
DSK:PAGE7.T2PK160,5417119 JUN 79 12:39 NEXT HIGHER ASSEMBLY:				SIZE CODE NUMBER REV.
FIRST USED ON OPTION/MODEL: 11/44 B-DD-KD11-Z-1				D FD KD11-Z-2 B

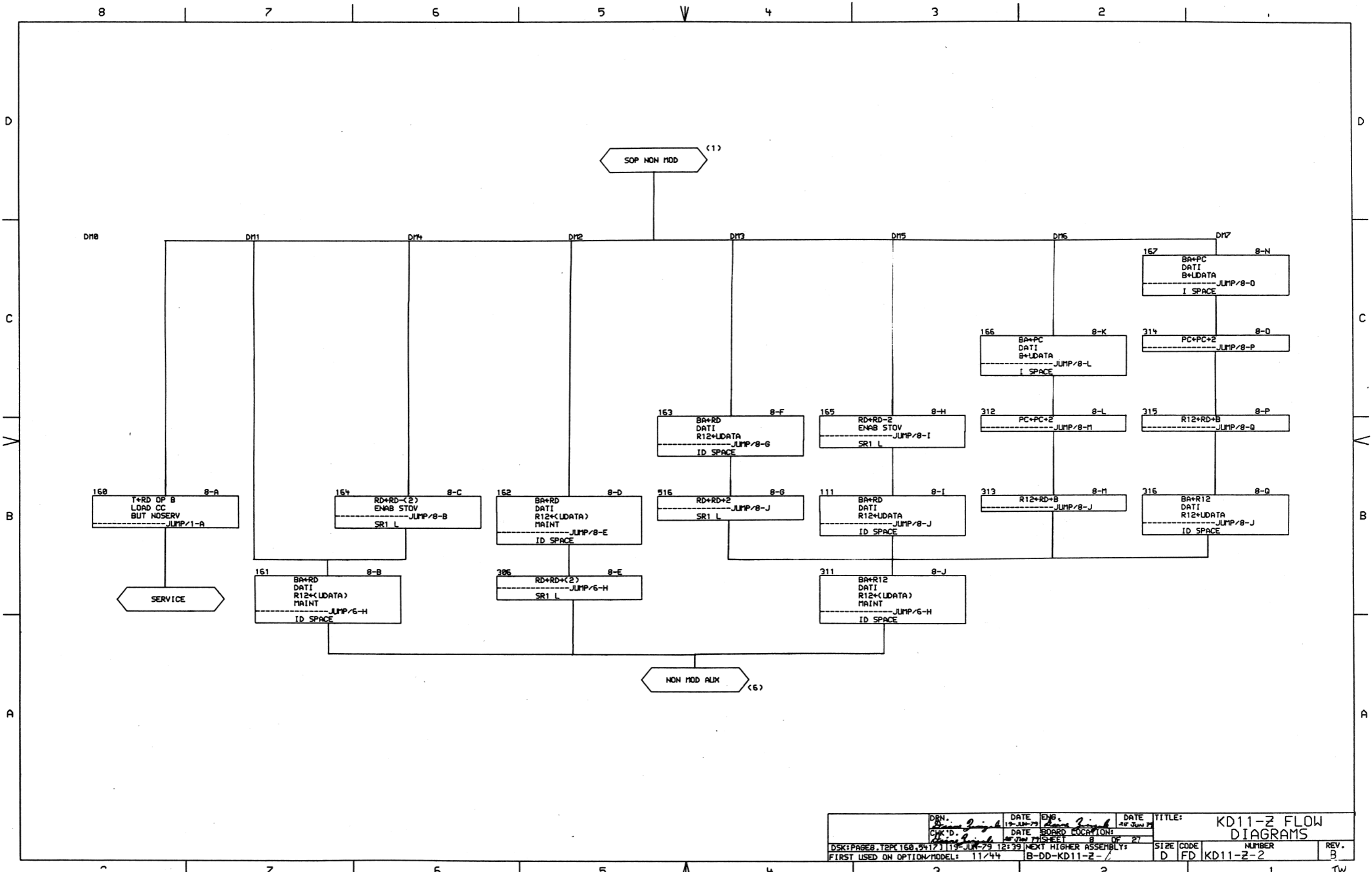

DRN.	DATE	ENG.	DATE	TITLE:
CHK'D.	DATE	BOARD LOCATION:	DATE	KD11-Z FLOW DIAGRAMS
DSK: PAGE 8, T2PK160, 5417113 JUN 79 12:39 NEXT HIGHER ASSEMBLY:				REV. B
FIRST USED ON OPTION/MODEL: 11/44 B-DD-KD11-Z-//				NUMBER
SIZE	CODE	NUMBER	REV.	
D	FD	KD11-Z-2	B	

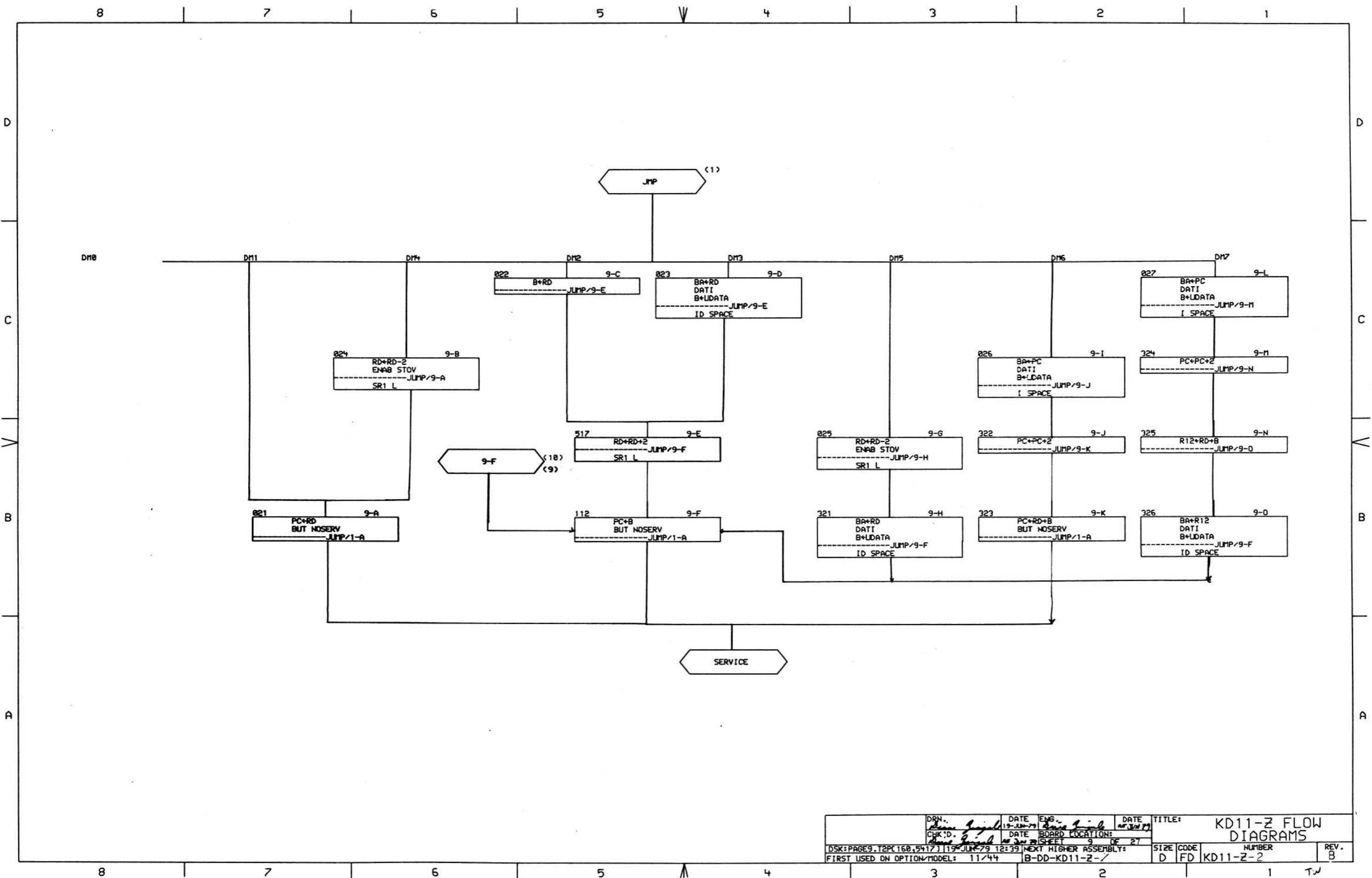

DRN. <i>Steve Engel</i>	DATE 12-18-79	ENG. <i>Steve Engel</i>	DATE 01-30-79	TITLE: KD11-Z FLOW DIAGRAMS
CHK'D. <i>Steve Engel</i>	DATE 01-20-79	BOARD LOCATION: 9	SHEET 27	SIZE CODE D FD
DSK:PAGE9.T2PC160,5417J19	JUN 79 12:39	NEXT HIGHER ASSEMBLY: B-DD-KD11-Z-//	NUMBER KD11-Z-2	REV. B
FIRST USED ON OPTION/MODEL: 11/44				

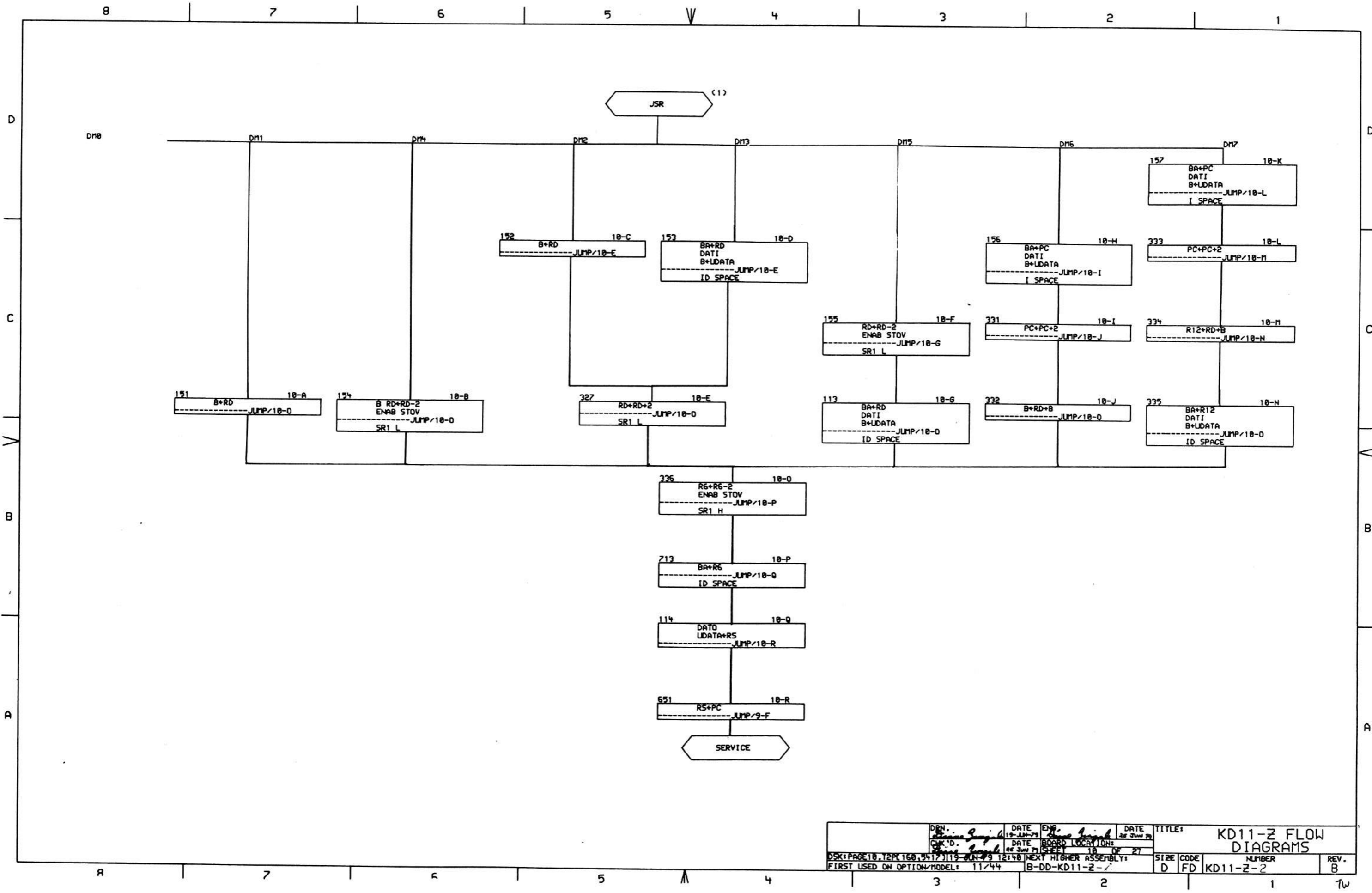

DPN 11-44	DATE 19-11-79	ENR Steve Lynch	DATE 26-11-79	TITLE KD11-Z FLOW DIAGRAMS
CHK'D Steve Lynch	DATE 26-11-79	BOARD LOCATION 18	SHEET 18	OF 27
OSK:PAGE 18, TOP 158, 5412, 119, JUN 79 12:48		NEXT HIGHER ASSEMBLY: B-DD-KD11-Z-2		SIZE D
FIRST USED ON OPTION/MODEL: 11/44		CODE FD	NUMBER KD11-Z-2	REV. B

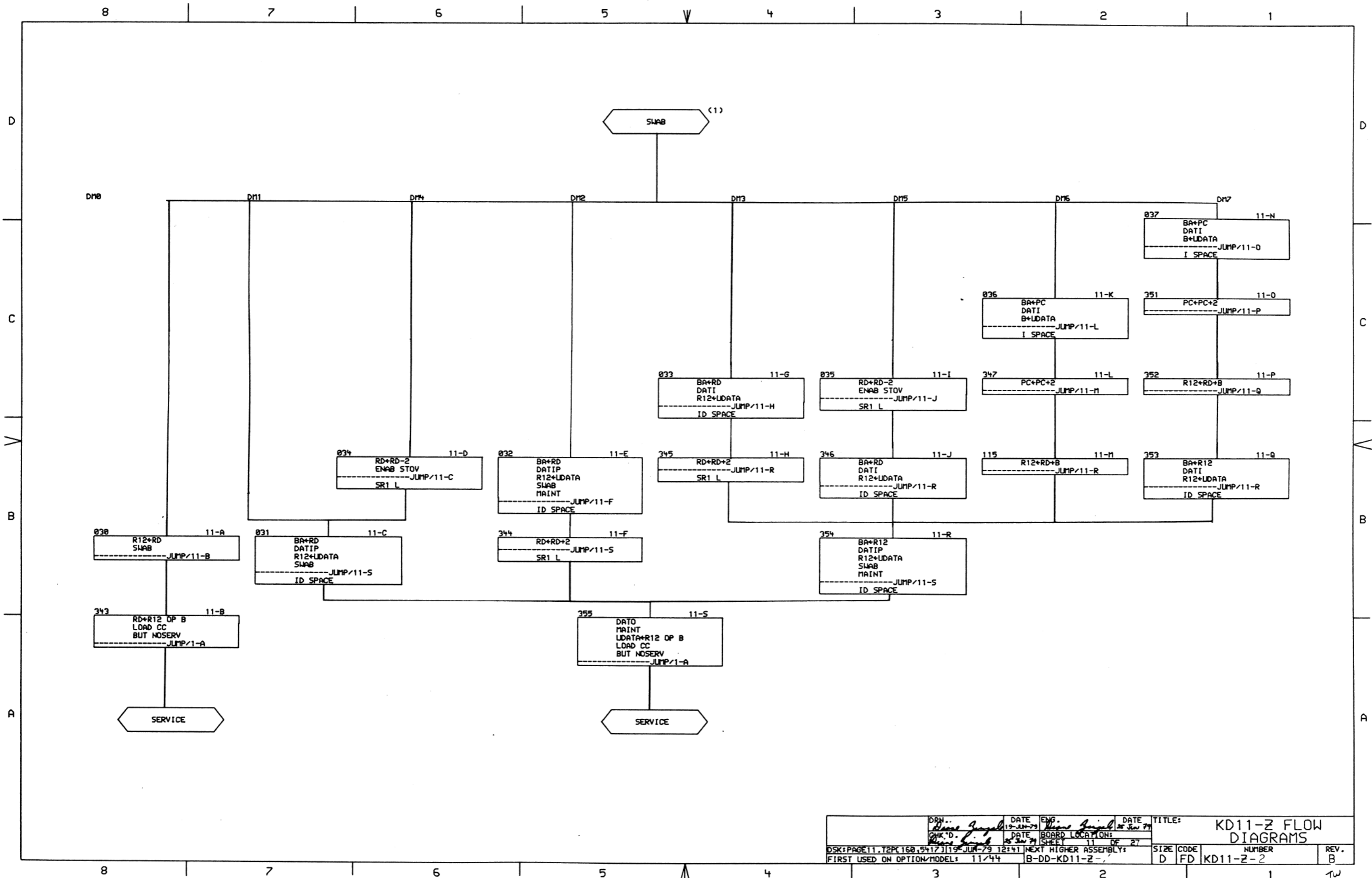

DRN..	DATE	ENG.	DATE	TITLE:	KD11-Z FLOW DIAGRAMS			
CHK'D.	DATE	BOARD LOCATION:	SHEET	11 OF 27	SIZE	CODE	NUMBER	REV.
FIRST USED ON OPTION/MODEL: 11/44				11/44	B-DD-KD11-Z-	D	FD	B

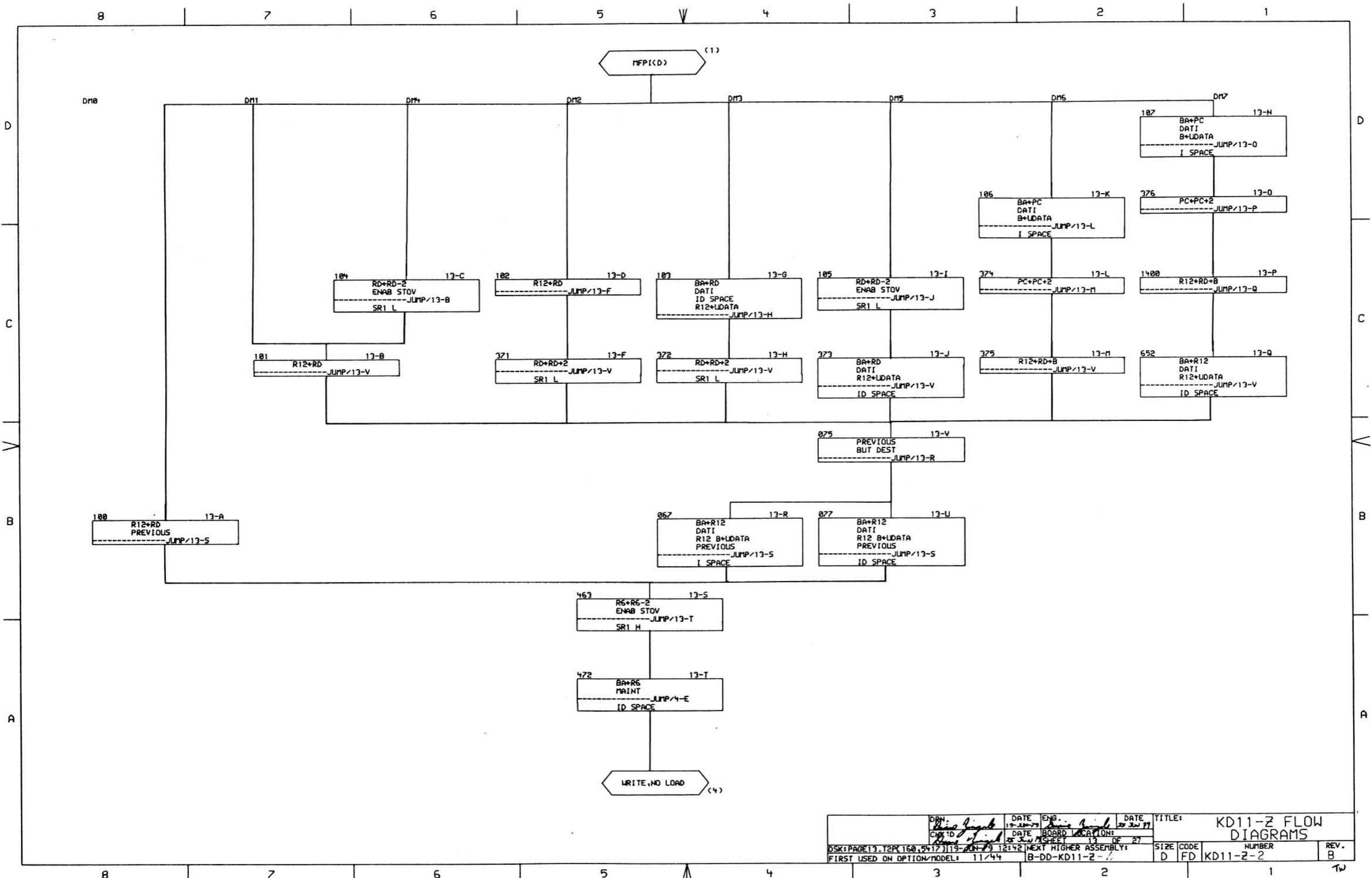

DRN. <i>David J. King</i>	DATE <i>19 JUN 79</i>	ENG. <i>David J. King</i>	DATE <i>20 Jun 79</i>	TITLE: KD11-Z FLOW DIAGRAMS
CHK'D <i>David J. King</i>	DATE <i>25 Jun 79</i>	BOARD LOCATION: <i>13</i>	SHEET <i>27</i>	SIZE CODE: D FD
OSK: PAGE 13, 12PC 160, 5412 J19 JUN 79 12:42 NEXT HIGHER ASSEMBLY: B-DD-KD11-Z				NUMBER: KD11-Z-2
FIRST USED ON OPTION/MODEL: 11/44				REV. B

TW

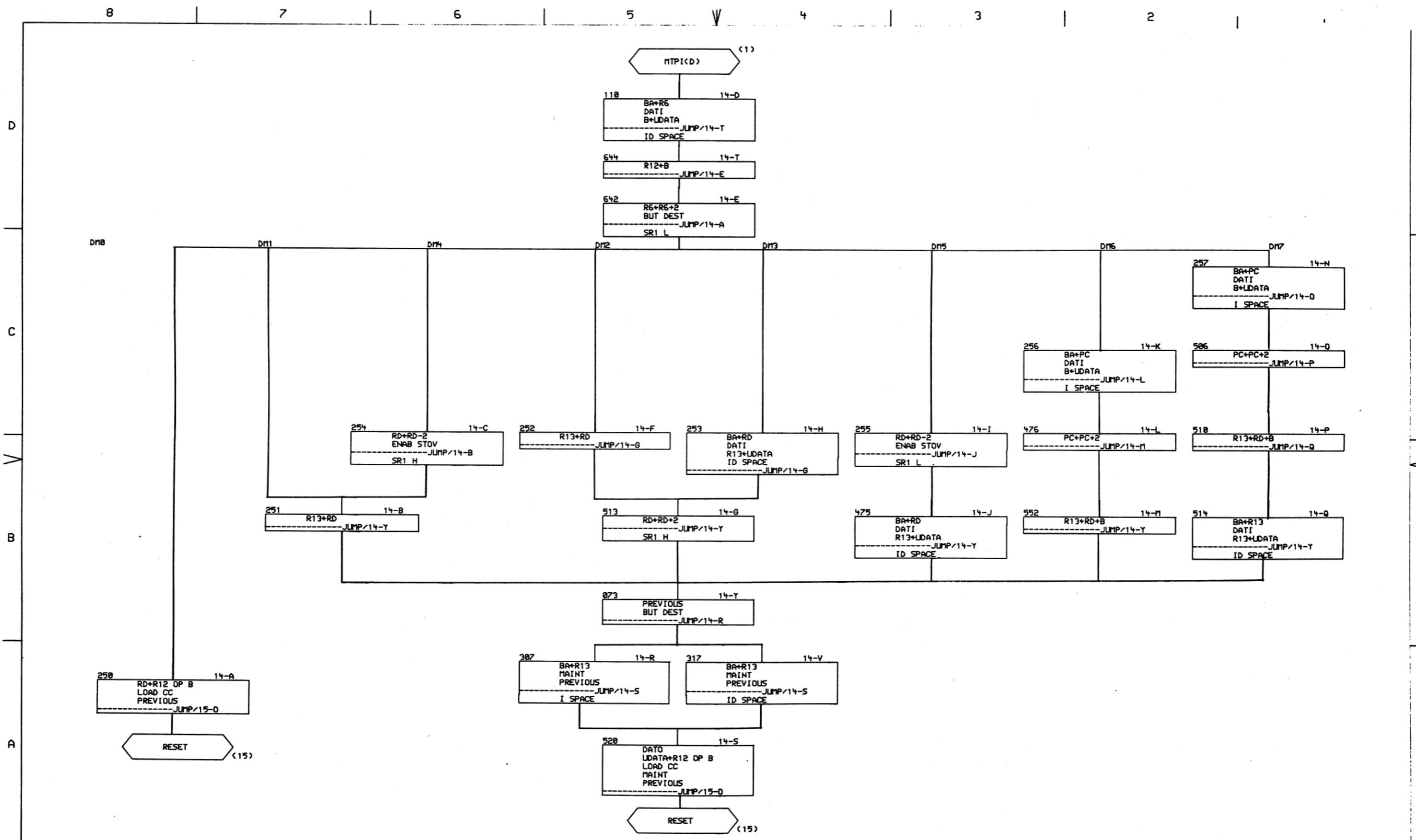

DRY	DATE	ENG	DATE	TITLE
<i>David J. ...</i>	25-JUN-79	<i>David J. ...</i>	25-JUN-79	KD11-Z FLOW DIAGRAMS
CHK'D	DATE	BOARD LOCATION	SHEET	OF
	11/44	B-DD-KD11-Z-0	14	27
DSK: PAGE 14, 12PC 168, 5417 J125 JUN 79 14:02 NEXT HIGHER ASSEMBLY:				SIZE CODE NUMBER REV.
FIRST USED ON OPTION/MODEL:				D FD KD11-Z-2 B

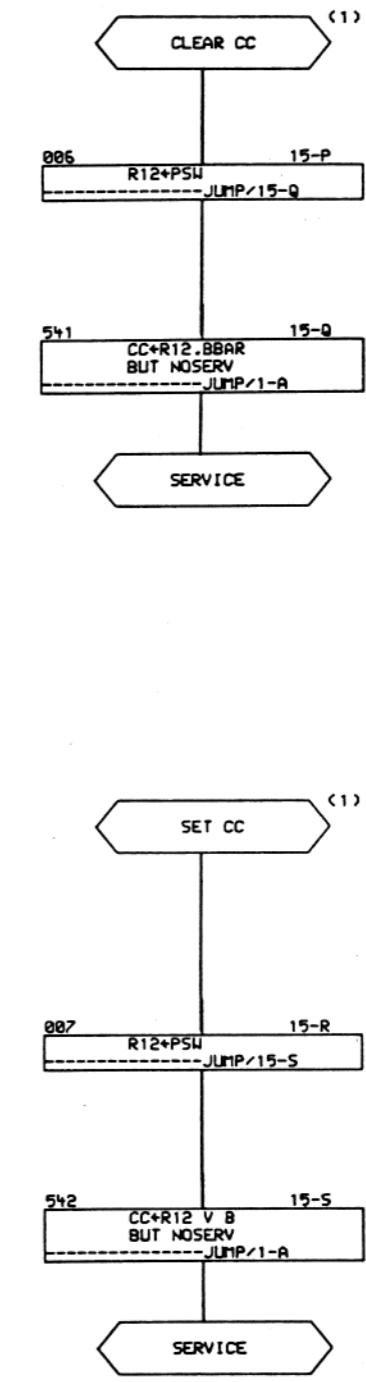
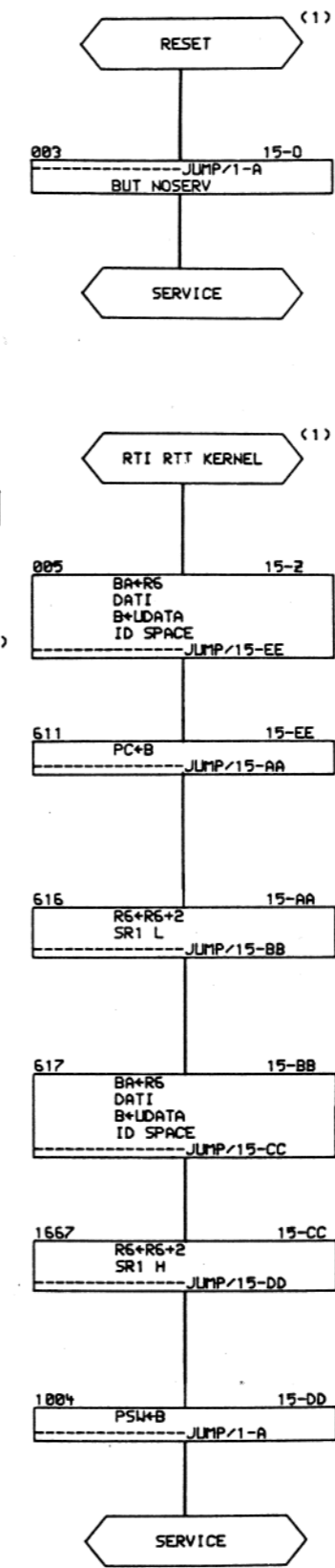
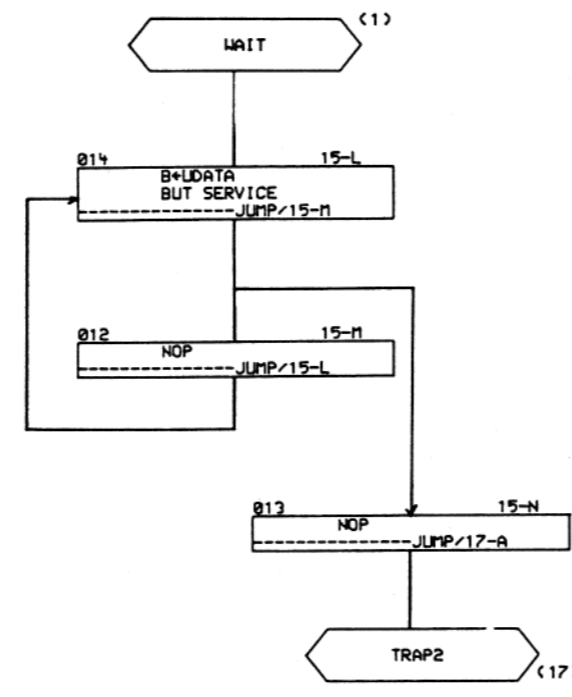
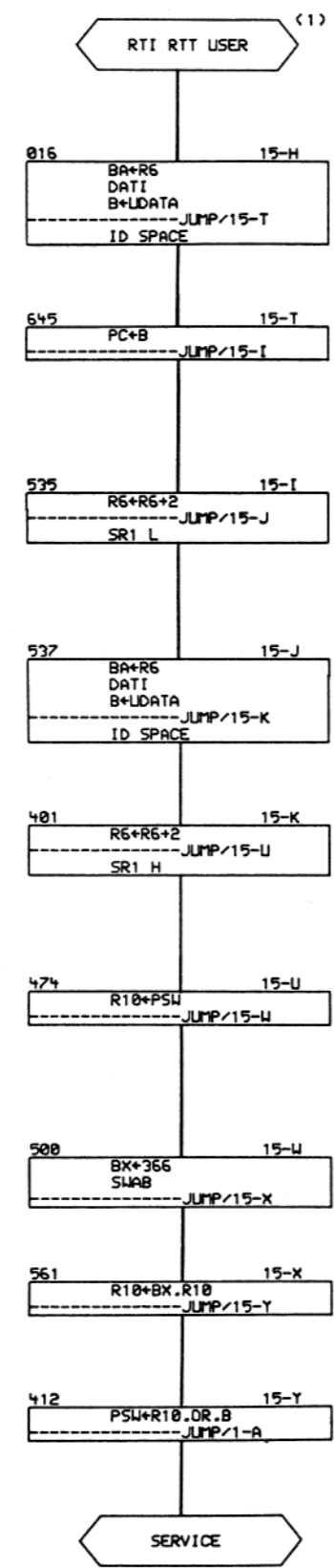
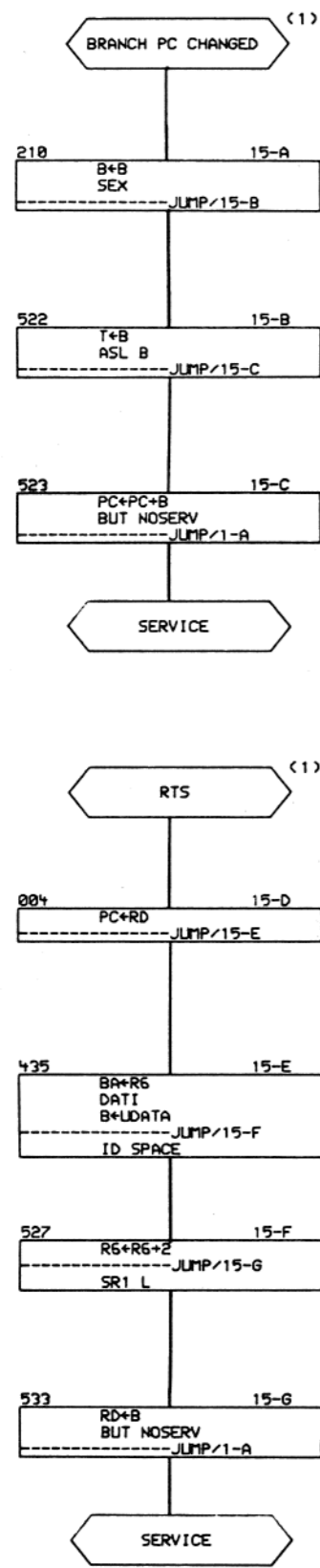

DRN. <i>James J. ...</i>	DATE ENG. <i>12 JUN 79</i>	DATE <i>28 JUN 79</i>	TITLE: KD11-Z FLOW DIAGRAMS
CHK'D. <i>James J. ...</i>	DATE BOARD LOCATION: <i>15</i>	DATE SHEET: <i>15</i>	REV. B
FIRST USED ON OPTION/MODEL: 11/44		SIZE CODE: D FD	NUMBER: KD11-Z-2

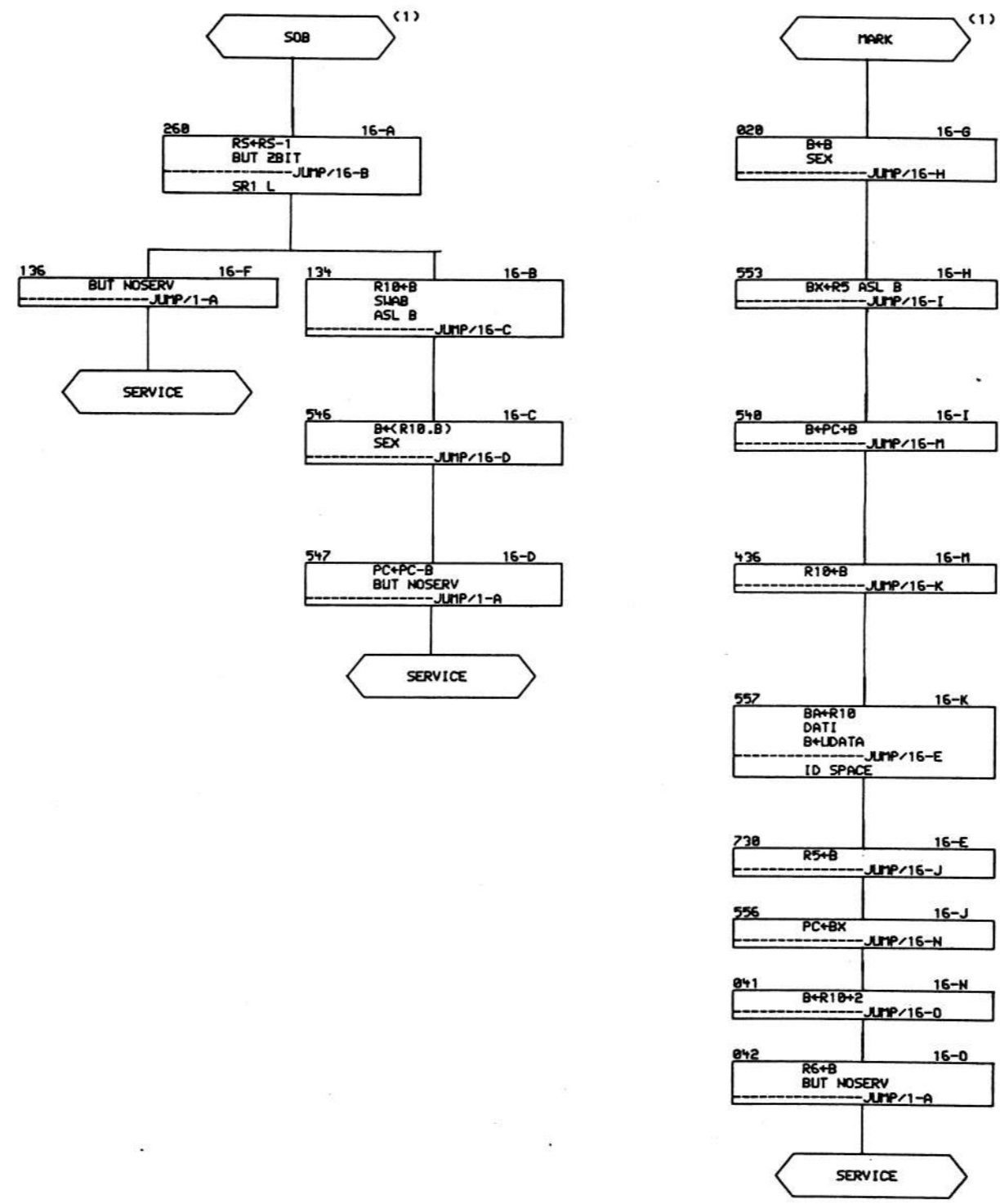

DRN. <i>James J. Smith</i>	DATE 19 JUN 79	ENG. <i>James J. Smith</i>	DATE 20 JUN 79	TITLE: KD11-Z FLOW DIAGRAMS
CHK'D <i>James J. Smith</i>	DATE 20 JUN 79	BOARD LOCATION: SHEET 16 OF 27	SIZE D	CODE FD
DSK: PAGE 16, T2PC160, 5417, 119 JUN 79 16:38		NEXT HIGHER ASSEMBLY: B-DD-KD11-Z-0	NUMBER KD11-Z-2	REV. B
FIRST USED ON OPTION/MODEL: 11/44				

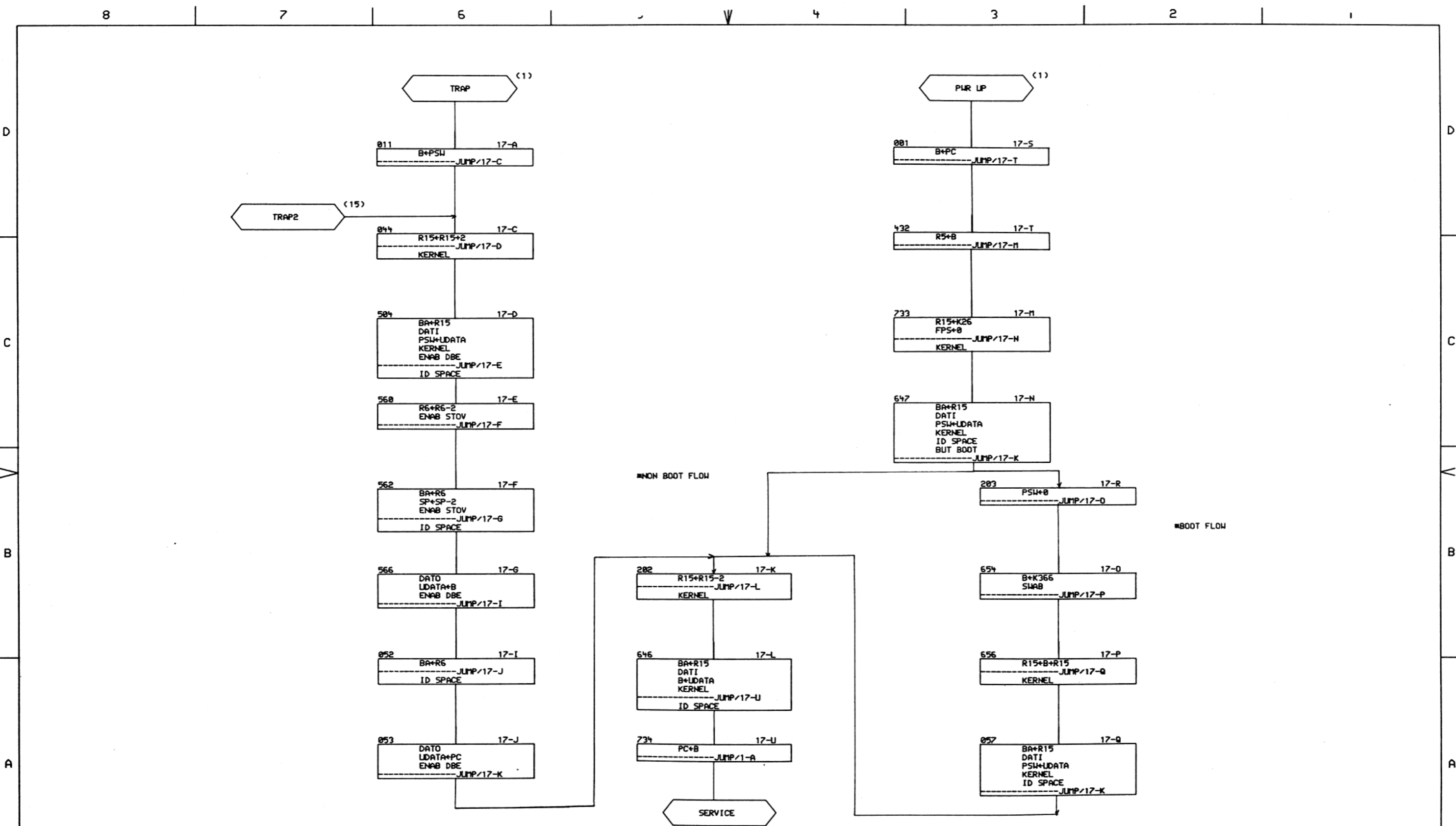

DRN:	DATE:	ENG.:	DATE:	TITLE:
CHK'D:	DATE:	BOARD LOCATION:	DATE:	KD11-Z FLOW
				DIAGRAMS
DSK: PAGE 17, T2PC 168, 5417	11/25 JUN 79	11:28	NEXT HIGHER ASSEMBLY:	SIZE CODE
FIRST USED ON OPTION/MODEL:	11/44	B-DD-KD11-2-0	NUMBER	REV.
			D	B
			FD	KD11-Z-2

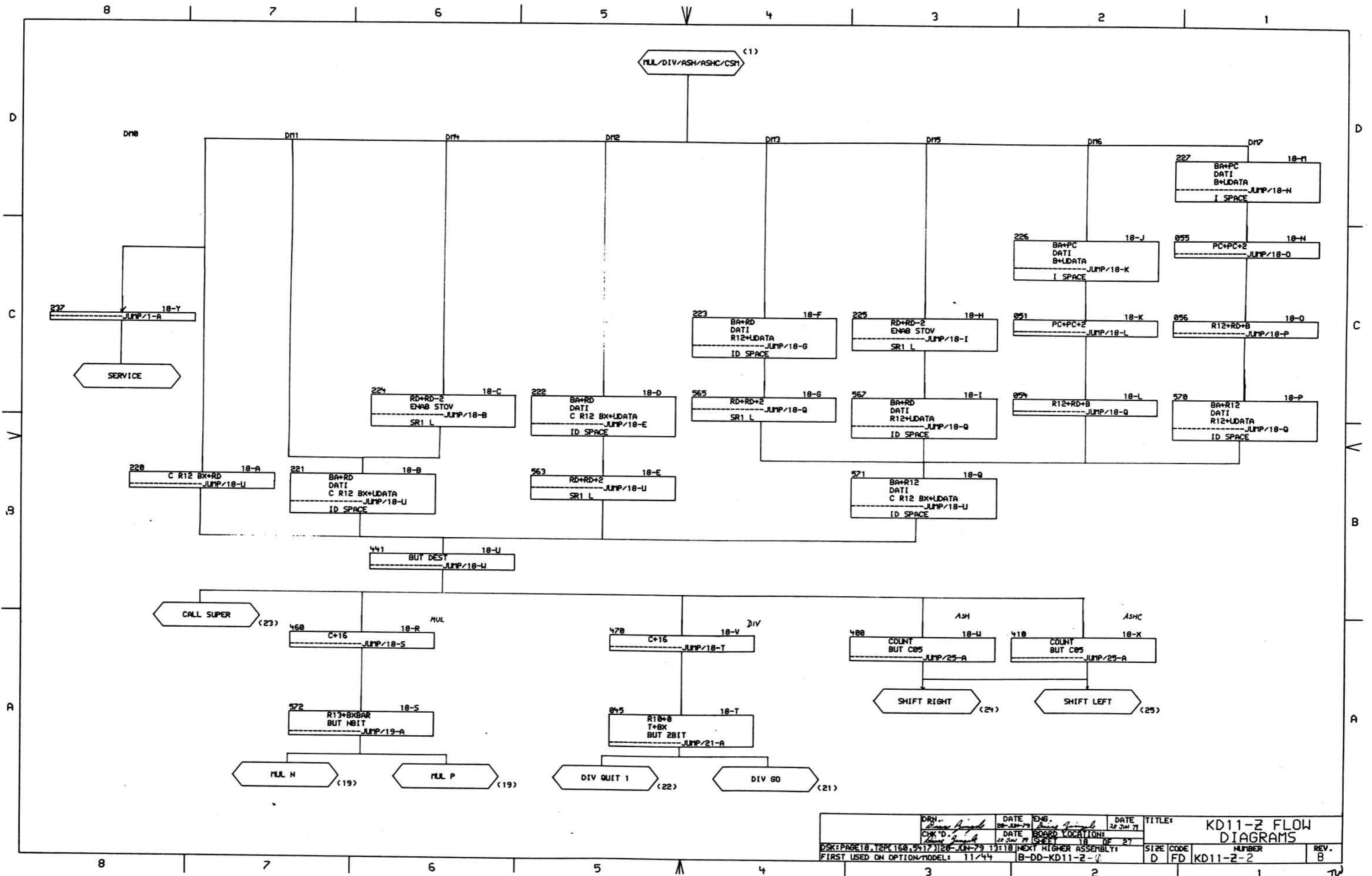

DRN: <i>James Angell</i>	DATE ENG: <i>28 JUN 79</i>	DATE: <i>28 JUN 79</i>	TITLE: KD11-Z FLOW DIAGRAMS
CHK'D: <i>James Angell</i>	DATE BOARD LOCATION: <i>18</i>	DATE: <i>28 JUN 79</i>	NUMBER: 18 OF 27
DATE: <i>28 JUN 79</i>	SHEET: <i>18</i>	REV.:	B
OSK: PAGE 18, 12PK 168, 517, 1128 JUN 79 13:18 NEXT HIGHER ASSEMBLY:		SIZE CODE: D FD	NUMBER: KD11-Z-2
FIRST USED ON OPTION/MODEL: 11/44		B-DD-KD11-Z-2	

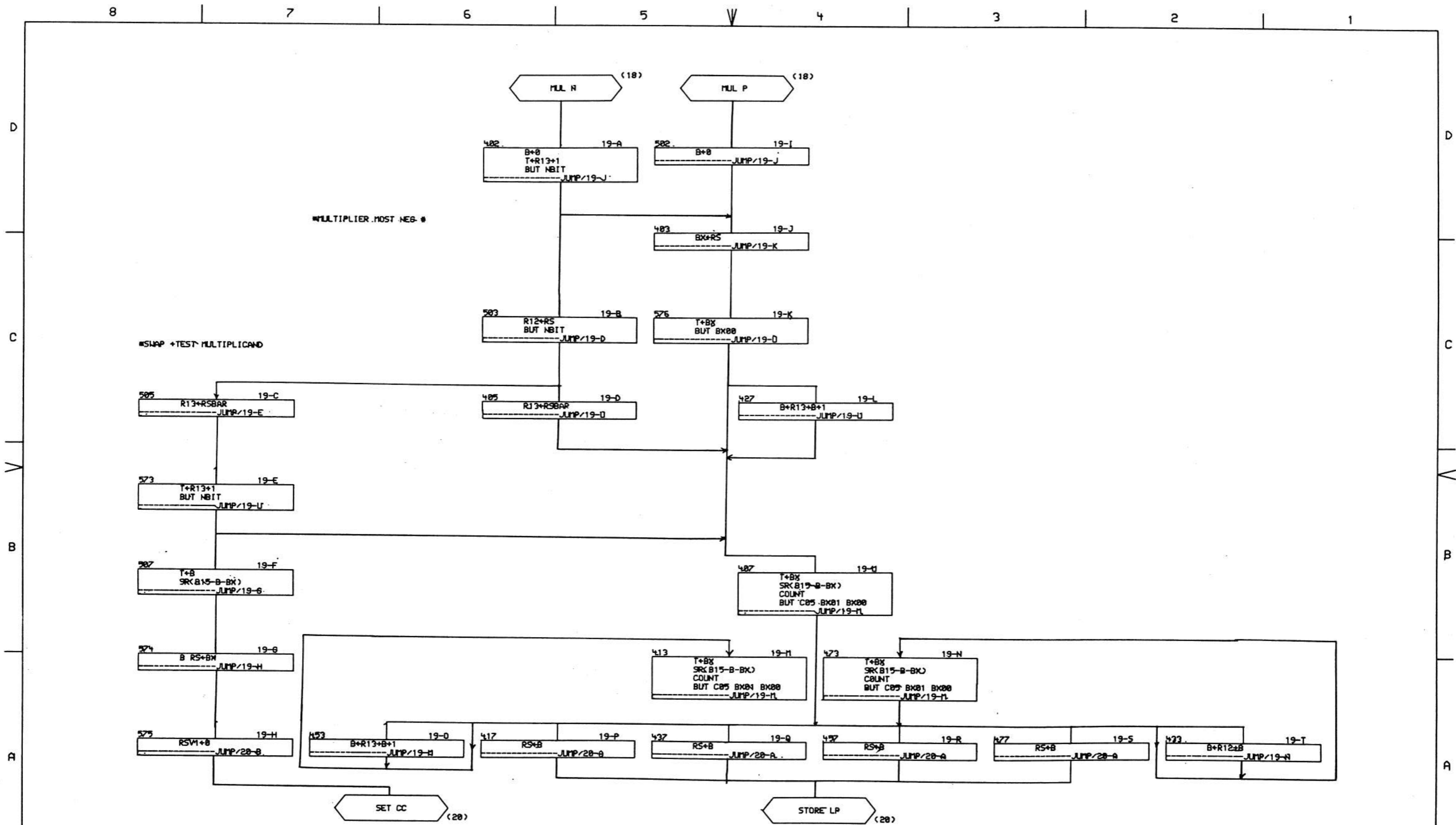

DRN. <i>James Lynch</i>	DATE <i>15-JUN-73</i>	ENG. <i>James Lynch</i>	DATE <i>15-JUN-73</i>	REV. <i>71</i>	TITLE: KD11-Z FLOW DIAGRAMS
CHK'D. <i>James Lynch</i>	DATE <i>15-JUN-73</i>	BOARD LOCATION <i>19</i>	REV. <i>27</i>	SIZE CODE <i>D FD</i>	NUMBER <i>KD11-Z-2</i>
FIRST USED ON OPTION/MODEL: <i>11/44</i>			NEXT HIGHER ASSEMBLY: <i>B-DD-KD11-Z-0</i>		REV. <i>B</i>

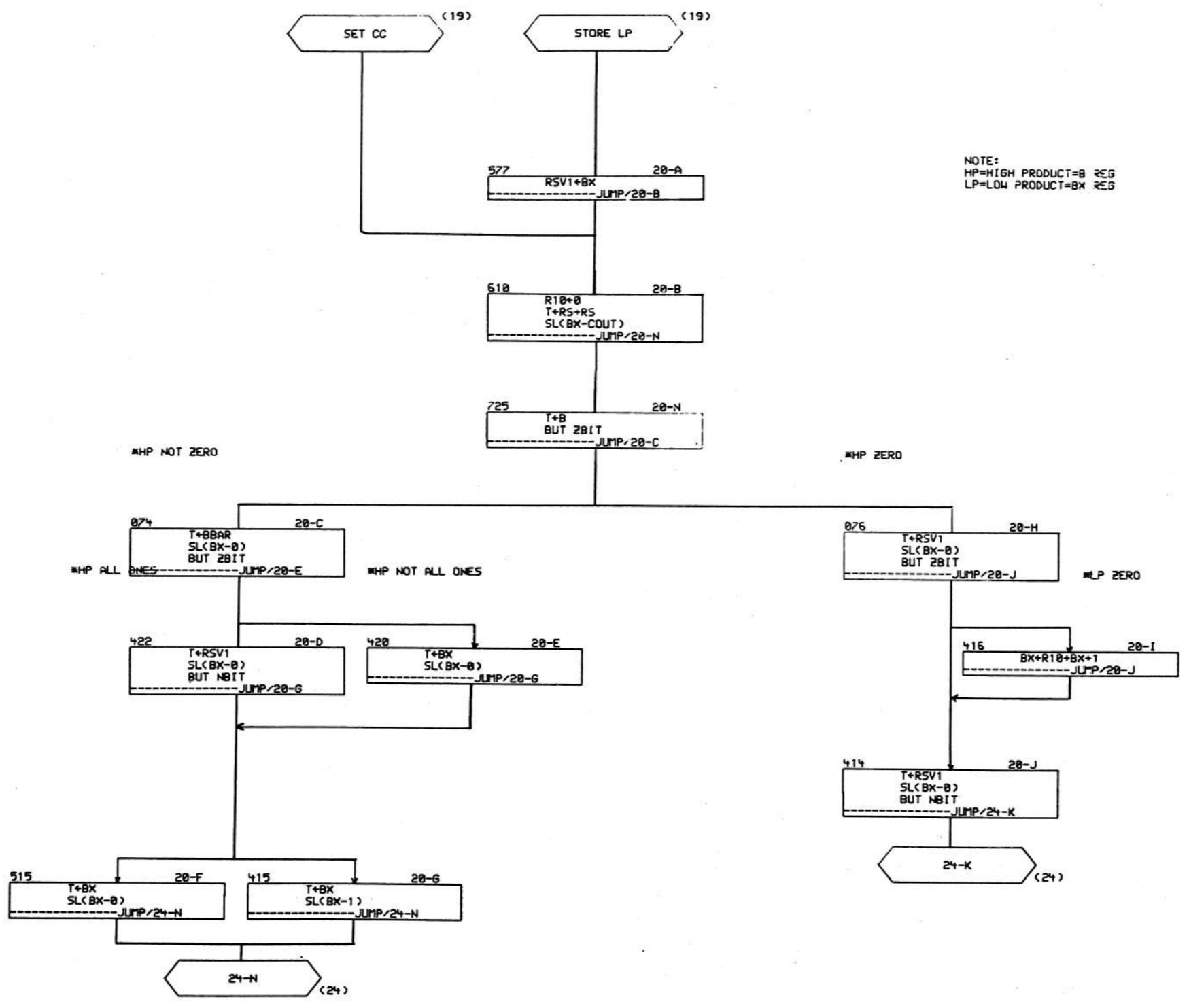

NOTE:
HP=HIGH PRODUCT=B REG
LP=LOW PRODUCT=BX REG

DRN	DATE	ENG	DATE	TITLE
<i>James J. ...</i>	12-21-73	<i>James J. ...</i>	20-30-73	KD11-Z FLOW DIAGRAMS
CHK'D.	DATE	BOARD LOCATION	SHEET	OF
<i>James J. ...</i>	11-19-73	3-DD-KD11-Z-2	28	27
FIRST USED ON OPTION/MODEL: 11/44		NEXT HIGHER ASSEMBLY:		SIZE CODE
		3-DD-KD11-Z-2		D FD
NUMBER			REV.	
KD11-Z-2			B	

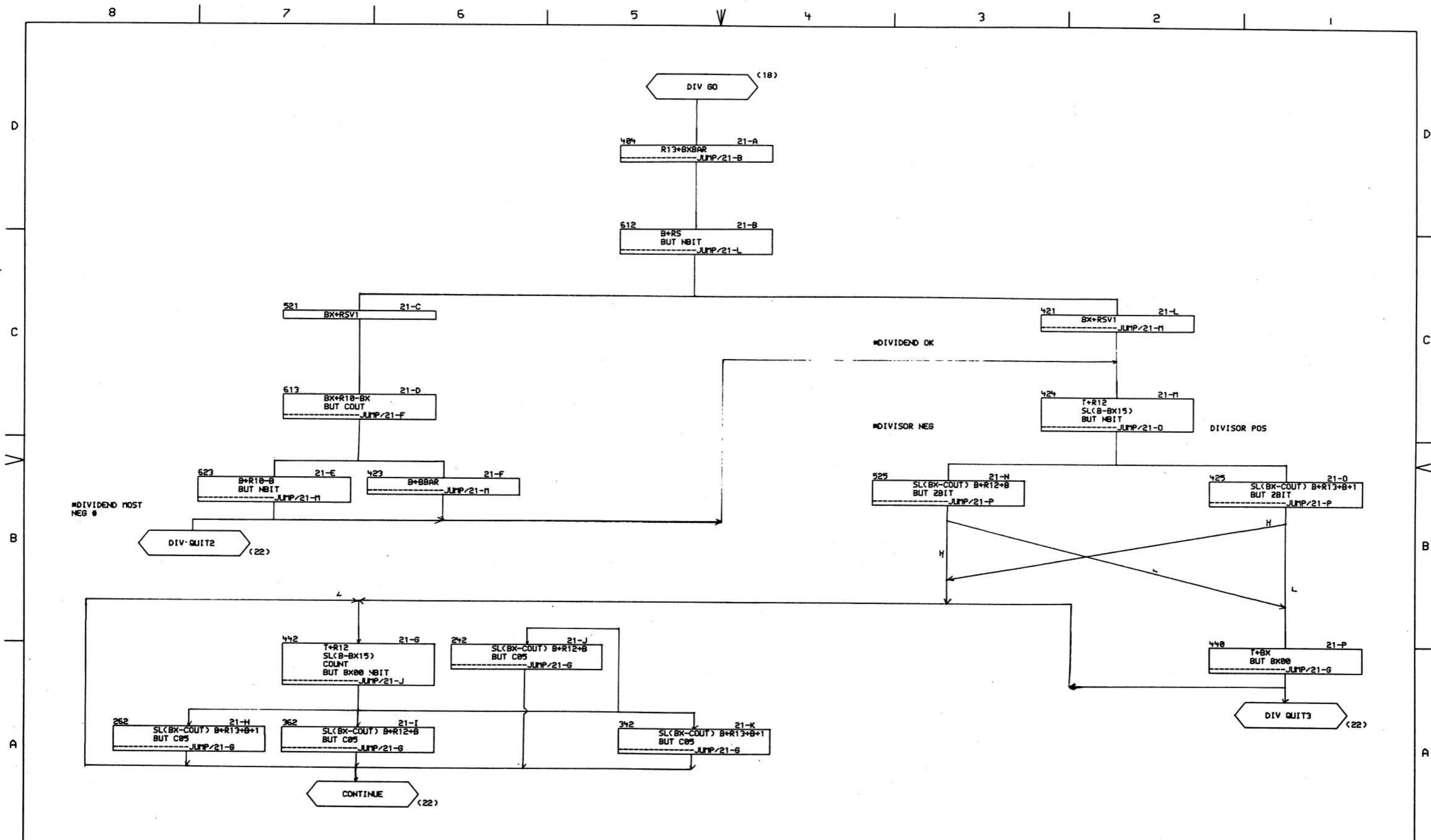

DRN. <i>Steve Grogan</i>	DATE 17-JUN-79	ENG. <i>Steve Grogan</i>	DATE 28-JUN-79	TITLE: KD11-Z FLOW DIAGRAMS
CHK'D. <i>Steve Grogan</i>	DATE 18-JUN-79	BOARD LOCATION: 21	SHEET 21	REV. B
OSK: PAGE 21, 12X160, 5417, 127 JUN 79 15:15		NEXT HIGHER ASSEMBLY: B-DD-KD11-Z-0		SIZE CODE D FD
FIRST USED ON OPTION/MODEL: 11/44		NUMBER KD11-Z-2		

8 7 6 5 4 3 2 1

D
C
B
A

D
C
B
A

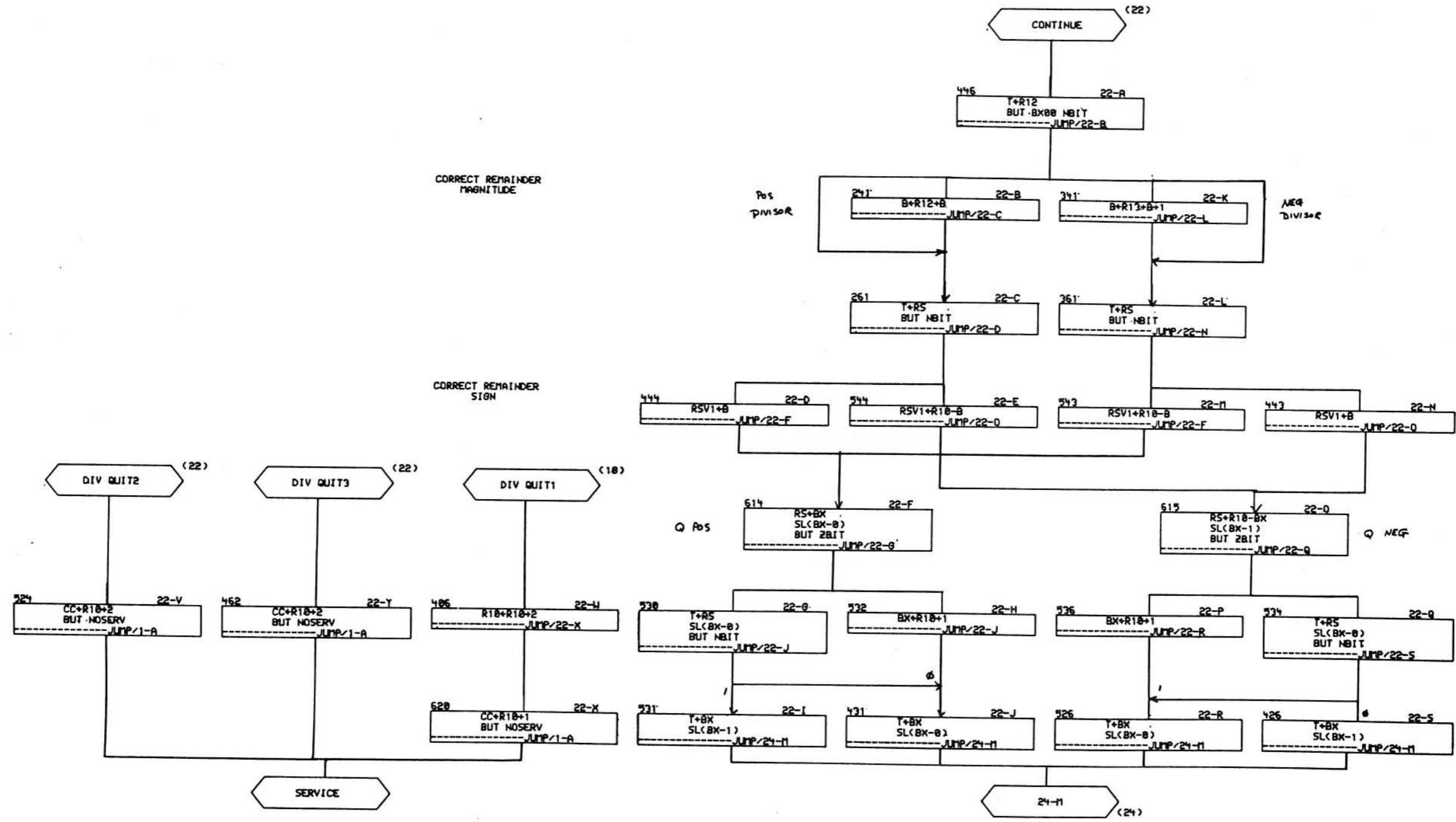

DRN: <i>James Joseph</i>	DATE: 20-JUN-79	ENG: <i>James Joseph</i>	DATE: 27-JUN-79	TITLE: KD11-Z FLOW DIAGRAMS
CHK'D: <i>James Joseph</i>	DATE: 27-JUN-79	DATE: 27-JUN-79	BOARD LOCATION: 22	NUMBER: 3
FIRST USED ON OPTION/MODEL: 11/44				REV: 3

8 7 6 5 4 3 2 1

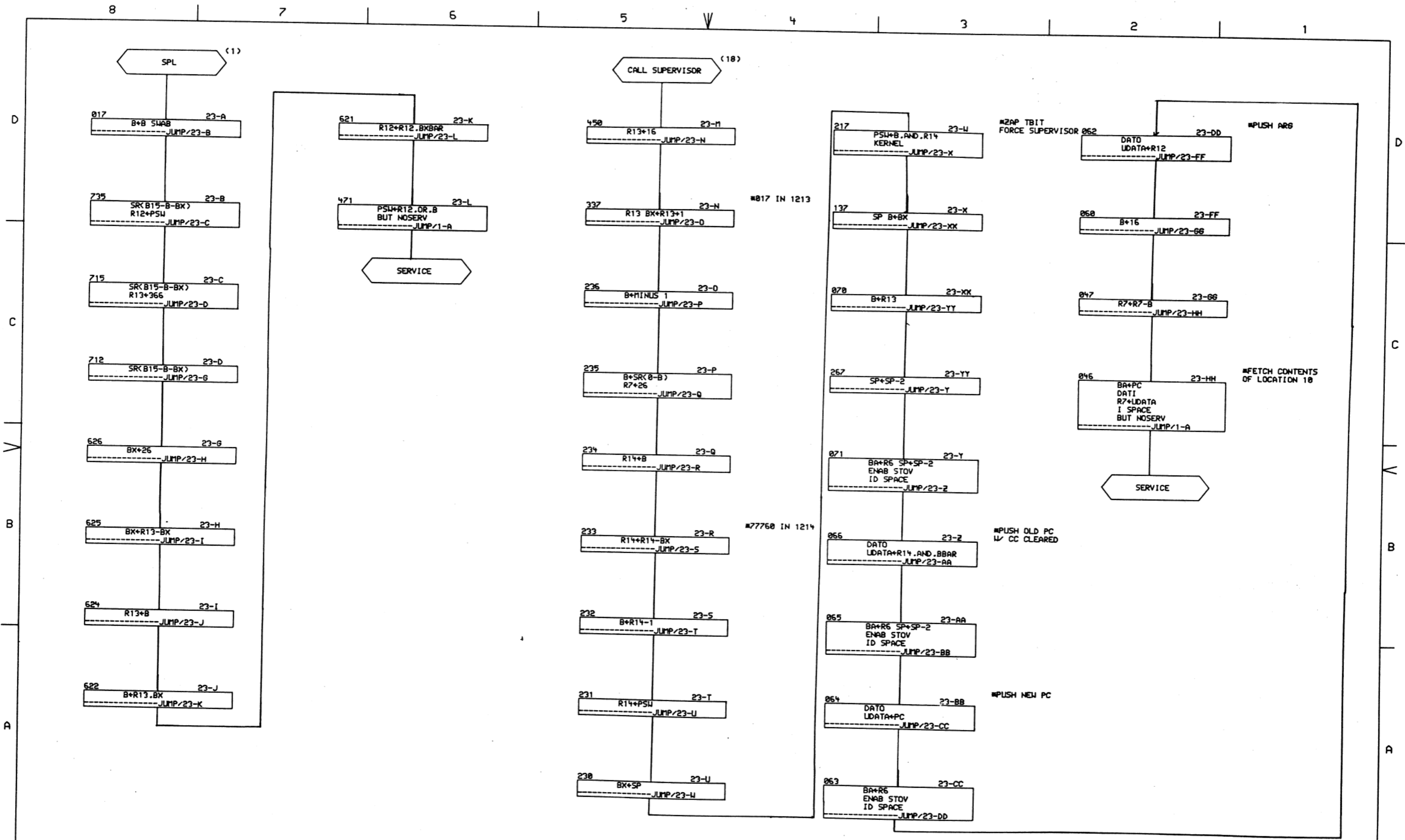

DRN. CHK'D.	DATE 20-11-73	ENG. D. J. ...	DATE 20-11-73	TITLE: KD11-Z FLOW DIAGRAMS
OSK: PAGE 23, TPC 160, 5417, 1120	DATE 20-11-73	BOARD LOCATION: SHEET 23 OF 27	SIZE CODE D FD	NUMBER KD11-Z-2
FIRST USED ON OPTION/MODEL: 11/44	DATE 20-11-73	NEXT HIGHER ASSEMBLY: B-DD-KD11-Z-C	REV. B	TW

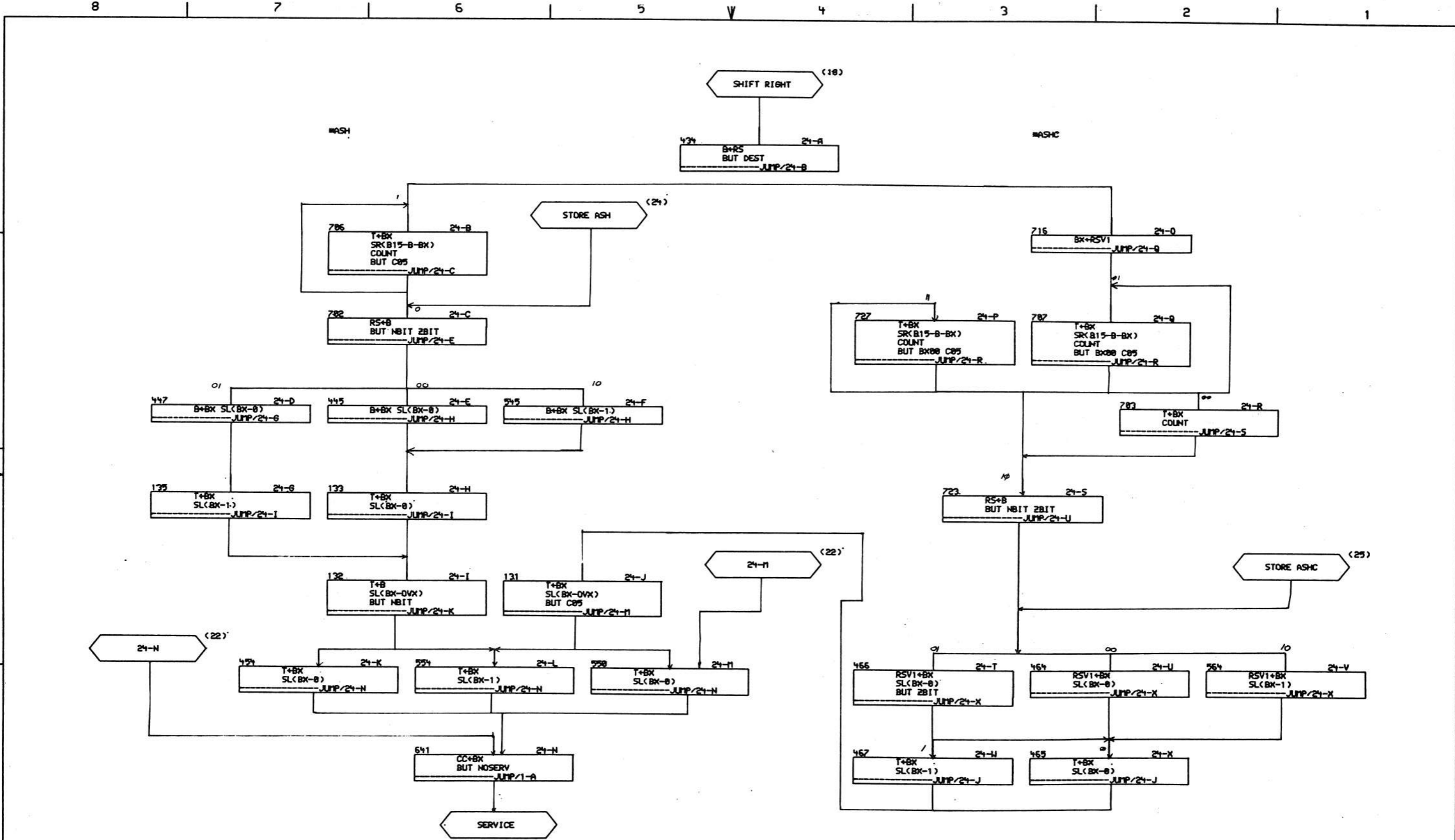

DRW. <i>[Signature]</i>	DATE 25 JUN 79	ENG. <i>[Signature]</i>	DATE 28 JUN 77	TITLE: KD11-Z FLOW DIAGRAMS
CHK'D <i>[Signature]</i>	DATE 28 JUN 79	BOARD LOCATION: 21	REV. B	NUMBER: D FD KD11-Z-2
FIRST USED ON OPTION MODEL: 11/44				SIZE CODE: D FD

8 7 6 5 4 3 2 1

D
C
B
A

D
C
B
A

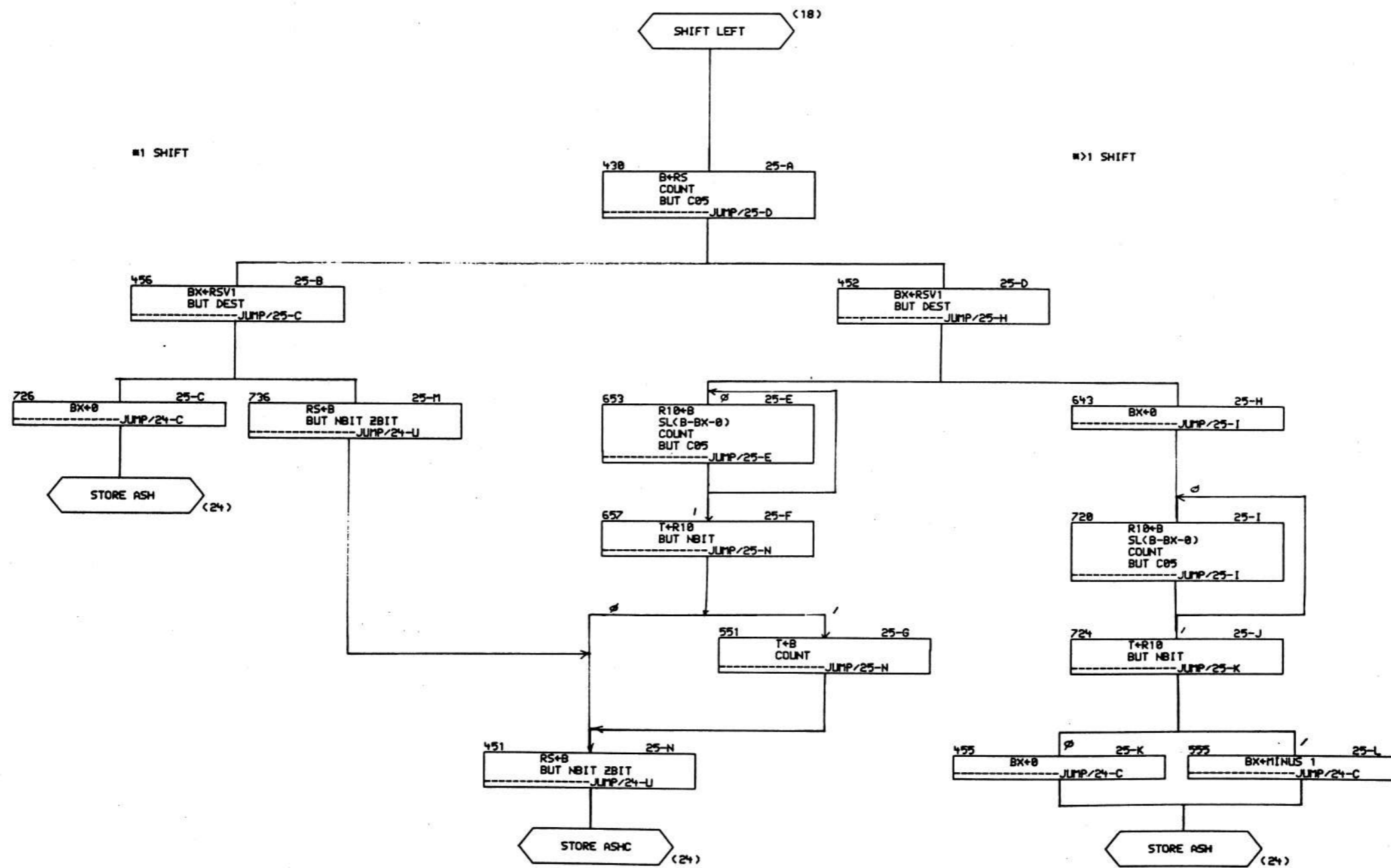

DRW <i>Steve Smith</i>	DATE 28 JUN 79	ENG. <i>Steve Smith</i>	DATE 27 Jun 79	TITLE: KD11-Z FLOW DIAGRAMS
CHK'D. <i>Steve Smith</i>	DATE 28 JUN 79	BOARD LOCATION 24 OF 27	SIZE CODE D FD	NUMBER KD11-Z-2
OSK: PAGE 25, T2PK 158, 5417, 1120, JUN-79 12:51		NEXT HIGHER ASSEMBLY: B-DD-KD11-Z-0	REV. B	
FIRST USED ON OPTION/MODEL: 11/44				

8 7 6 5 4 3 2 1

TW

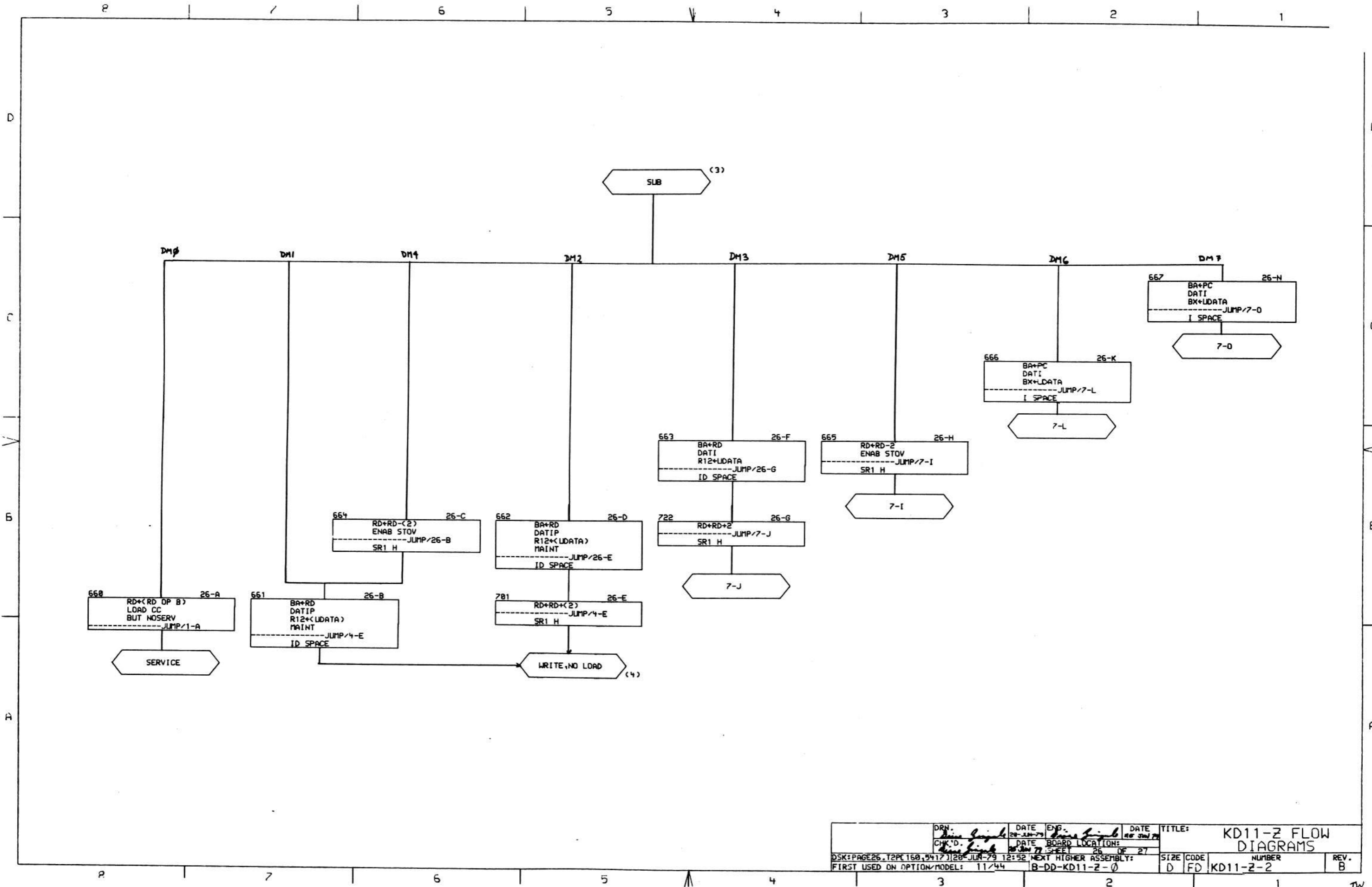

DRN. <i>Don Finch</i>	DATE 28 JUN 79	ENG. <i>Don Finch</i>	DATE 28 JUN 79	TITLE: KD11-Z FLOW DIAGRAMS
CHK'D. <i>Don Finch</i>	DATE 28 JUN 79	BOARD LOCATION: 25	SIZE CODE D FD	NUMBER KD11-Z-2
FIRST USED ON OPTION/MODEL: 11/44			NEXT HIGHER ASSEMBLY: B-DD-KD11-Z-0	REV. B

