



# PDP-11

Systems & Options Catalog

October-December 1983

digital

The information in this document is subject to change without notice and should not be construed as a commitment by Digital Equipment Corporation. Digital Equipment Corporation assumes no responsibility for any error that may appear in this catalog.

This Product Catalog was designed, produced, and typeset by Digital's Corporate Marketing Services using an in-house text-processing system.

Correspondent, DATATRIEVE, DEC, DECmate, DECnet, DECmailer, DECstart, DECword, DECword/DP, DECwriter, Digital logo, FALCON, FMS-11, IAS, Internet, LA, Letterprinter 100, Letterwriter 100, MICRO/PDP-11, MICRO/J-11, MICRO/PDP-11, MICRO/T-11, MicroPower/Pascal, PACKETNET, PDP, P/OS, Professional 325 and 350, PROVUE, Q-bus, Rainbow 100, ReGIS, RSTS, RSX, RT-11, UNIBUS, VAX, VMS, VT are trademarks of Digital Equipment Corporation.

# New Products From DIGITAL

---



**MICRO/PDP-11**—the performance of a minicomputer in a compact, economical microcomputer. Now there is **Micro/R SX**, especially designed for use on the **MICRO/PDP-11**.

**New Packaging for PDP-11/24s and PDP-11/44s**— from boxes to building blocks to complete packaged systems.

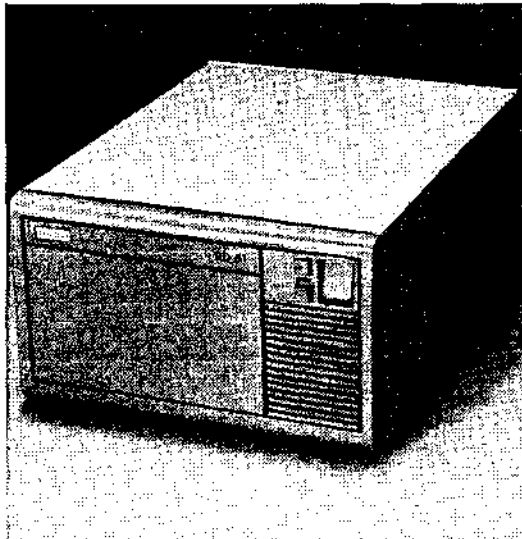

## **New Q-bus Mass Storage Packaging**

- Adds 10 MB to the **MICRO/PDP-11**
- Adds removable floppies to **Q-bus** systems

# Table of Contents

---

<b>Introduction</b> . . . . .	i
Overview and How to Use . . . . .	ii
Ordering and Configuring Information . . . . .	iv
Supporting Products . . . . .	viii
<b>Systems</b> . . . . .	1-1
System Selection Chart . . . . .	1-3
Q-bus System Chart . . . . .	1-5
MICRO/PDP-11 Computer Models & Systems . . . . .	1-8
PDP-11/23-PLUS Computer Models & Systems . . . . .	1-12
UNIBUS System Chart . . . . .	1-22
UNIBUS Rackmountable Computer Models . . . . .	1-26
UNIBUS Kernel Systems . . . . .	1-32
UNIBUS Building Blocks . . . . .	1-36
UNIBUS Packaged Systems . . . . .	1-40
UNIBUS Expansion Hardware . . . . .	1-48
<b>Options</b> . . . . .	2-1
Option Selection Chart . . . . .	2-3
Processor Options and Memories . . . . .	2-6
Communication and Realtime Options . . . . .	2-8
Communication Cables Chart . . . . .	2-18
Options Configuring Charts . . . . .	2-28
<b>Components</b> . . . . .	3-1
Component Selection Charts . . . . .	3-3
Microprocessor Chips . . . . .	3-4
Single-Board Processors . . . . .	3-5
Processor Options and Memories . . . . .	3-8
Enclosures, Cables and Backplanes . . . . .	3-9
Microcomputer Development Systems and Tools . . . . .	3-10
Component Configuring Charts . . . . .	3-11
<b>Disks &amp; Tapes</b> . . . . .	4-1
Disk Selection Chart . . . . .	4-3
Controllers . . . . .	4-4
Fixed- and Removable-Disk Subsystems . . . . .	4-7
Magnetic Tape Selection Chart . . . . .	4-19
Magnetic Tapes . . . . .	4-20
Magnetic Tape Configuring Charts . . . . .	4-25
<b>Personal Computers</b> . . . . .	5-1
Rainbow 100 . . . . .	5-4
DECmate II . . . . .	5-6
Professional 325 and 350 . . . . .	5-9
<b>Terminals &amp; Printers</b> . . . . .	6-1
Video Terminal Selection Chart . . . . .	6-3
Video Terminals . . . . .	6-4
Video Terminal Configuring Chart . . . . .	6-11
Hardcopy Terminal & Lineprinter Selection Charts . . . . .	6-13
Hardcopy Terminals . . . . .	6-14
Lineprinters . . . . .	6-19
Cardreaders . . . . .	6-25
Hardcopy Terminal & Lineprinter Configuring Charts . . . . .	6-26
<b>Software</b> . . . . .	7-1
Software Selection Chart . . . . .	7-4
Operating Systems Selection Chart . . . . .	7-8
PDP-11 Operating Systems . . . . .	7-6
Operating System Ordering Information . . . . .	7-17
Programming Languages . . . . .	7-20
Programming Languages Ordering Chart . . . . .	7-22
Applications Packages . . . . .	7-22

# Table of Contents

---

Application Packages Ordering Chart . . . . .	7-27
Software Binary License Agreements . . . . .	7-30
<b>Networks</b> . . . . .	8-1
Networking Selection Chart . . . . .	8-3
DECnet . . . . .	8-4
Internets . . . . .	8-6
Packetnet System Interfaces . . . . .	8-9
Communication Software Ordering Information . . . . .	8-11
<b>Customer Services</b> . . . . .	9-1
Field Service . . . . .	9-3
Software Services . . . . .	9-5
Educational Services . . . . .	9-7
<b>Index</b> . . . . .	10-1
<b>Appendix A</b> . . . . .	A-1

12

13

14

15

16

17

18

19

20

21

22

23

24

25

26

27

28

29

30

31

32

33

34

35

36

37

38

39

40

41

42

43

44

45

46

47

48

49

50

51

52

53

54

55

56

57

58

59

60

61

62

63

64

65

66

67

68

69

70

71

72

73

74

75

76

77

78

79

80

81

82

83

84

85

86

87

88

89

90

91

92

93

94

95

96

97

98

99

100

# Introduction

---

The success of Digital's products is built on the concept of architectural compatibility. One of the leading examples of Digital's superior architecture is the PDP-11. This uniquely successful computer family is based upon a compatible set of processors, ranging from a single chip to full multipurpose computer systems. All of these processors are built using a common hardware architecture. You can upgrade or expand any Digital system by adding memory, peripherals, or processors without introducing major incompatibilities into your system. PDP-11 minicomputers and microcomputers are engineered to provide increased functionality in smaller, more economical packages, while still utilizing the same powerful software as their larger predecessors. Today's PDP-11s provide a full product range from chips to systems to networks.

Complementing these computers are a complete array of operating systems: realtime multitasking systems, timesharing interactive multiuser systems, compact realtime single-user systems, small and midrange commercial systems, multiuser data management systems, and a development and runtime system designed expressly for microcomputers. With Digital's Operating System General License, you can choose the particular operating system that best fits your application needs. Every operating system equips you with a full set of application development tools, and every processor can support additional language compilers, networking options, and an ever-expanding selection of application software.

The PDP-11 Systems and Options Catalog is released each quarter to provide you with the most accurate and up-to-date information on currently available PDP-11 systems, options, and software products. Whether you are a new or existing PDP-11 customer, this catalog will help you select the best Digital products to meet your computing needs.



## How to Use This Catalog

The following Section Overview will help you find all of the appropriate product information you require, whether you want to expand your current system, configure a new system, or perform your own integration of system components. The catalog has been divided into nine major sections. There is also an index and appendix. Each section begins with a product selection chart that includes page references so that you can quickly determine what products are offered and where they can be found in that section. Configuration and site preparation charts contain detailed technical specifications (power requirements, mounting codes, etc.) for all products, and are located at the end of each section.

Software Ordering Information is contained at the end of the Software and Networking Sections.

**Section 1 - Systems** describes the PDP-11 computer models and systems, beginning with the Q-bus family of computers—the MICRO/PDP-11, the PDP-11/23-PLUS and the PDP-11/23-S and following with the UNIBUS family of computers—the PDP-11/24 and PDP-11/44. Each system model description includes features and benefits, performance characteristics, expansion information, site preparation figures, ordering information, and a checklist of supported options.

A diagram of the CPU box and a graphic system configurator are also included for each computer model. The CPU box shows the location of modules bundled in the system (for example, the CPU and/or controller), the location of dedicated modules (for example, memory and/or floating point processor) and expansion slots (for example, hex, quad, extended Q-bus quad or double). The system configurator is designed in the form of a worksheet to enable you to write down the options you wish to purchase, and calculate the deduction of the DC power and bus loads drawn by each option (see the sample worksheet on the next page).

If you run out of DC power in the CPU box before adding on all your options, you will need to purchase an expansion box. Should you run out of room in the CPU cabinet for another expansion box, then it is necessary to purchase another cabinet. These expansion products are also described in this section.

**Section 2 - Options** provides all the necessary information for selecting and configuring the processor, memory, communication, and realtime I/O options that are available for the Q-bus or UNIBUS systems you have selected. The new flexible option ordering plan is described in detail at the beginning of this section. **Please read it over carefully**, as many of the options have new order code designations.

**Section 3 - Components** includes Q-bus chip and board-level products for customers who want to perform their own system integration. A complete selection of Q-bus processor and memory options, enclosures, backplanes and development tools is included.

**Section 4 - Disks and Tapes** describes the disk and magnetic tape subsystems available for the Q-bus and UNIBUS systems. Included is a description of the Digital Storage Architecture (DSA) and both the UDA50 and RQDX1 controllers. Again, each product description includes complete performance characteristics and ordering information.

**Section 5 - Personal Computers** describes Digital's family of personal computers: DECmate II—tailored to meet the needs of the small business and office environments; the Rainbow 100—designed for popular industry-standard personal computer applications, and the Professional 325 and 350—designed to bring minicomputer performance and professional applications to personal computing. These product descriptions include some of the hardware and software options available for each model. For complete information on hardware and software options, consult the Personal Computer Summer Catalog.

**Section 6 - Terminals and Printers** include Digital's wide variety of video terminals, graphics terminals, hardcopy terminals, page and lineprinters that are available for Q-bus and UNIBUS systems.

**Section 7 - Software** describes the seven Digital operating systems that can run on your PDP-11, plus optional software—programming languages, information management, word processing, graphics, and application packages—you can add. License and ordering information is provided.

**Section 8 - Networking** provides information on Digital's network architecture and our communication software. The communication software includes: DECnet—for Digital-to-Digital communication, either locally or remotely; Internets—for connecting Digital systems to non-Digital systems; and Packetnet System Interfaces—for connection of systems through a public packet-switching network.

**Section 9 - Customer Services** summarizes some of the excellent support services Digital offers, including Field Service, Software Services, and Educational Services to meet your hardware, software, and training needs.

**Section 10 - Index** will help you find the information you need quickly and easily.

**Appendix A - Tables** for translating the old Q-bus and UNIBUS option order codes to the new ordering nomenclature.



# Introduction

---

The following terminology is used in this catalog for configuring and ordering PDP-11 products. A sample configurator worksheet is included to illustrate how to add options to your system and to help define the terms used in the product descriptions and in the ordering and configuring charts.

## Ordering Information

The model numbers are the designations used to order products in this catalog. For products that are voltage/frequency dependent the designations are in the following format. The 120VAC/60Hz variation of the model appears first, followed by the 240VAC/50Hz system in parentheses. For example with model number H7750-BA(BD), the H7750-BA designates the 120 VAC, 60 Hz model. The H7750-BD designates the 240 VAC, 50 Hz model.

Communications and I/O options have new order code designations which indicate whether the options are purchased with a new system or added to an existing system. The following terms describe this flexible option ordering plan:

<b>System option</b>	Ordered with CPU. Includes the generic option and all the appropriate cabling, I/O connection panel inserts and bracket hardware for installation on that CPU. <b>Example:</b> DZV11-DP.
<b>Upgrade option</b>	Ordered as an add-on to an existing system. Includes only the <b>base option</b> module. Requires a <b>cabinet kit</b> for installation. <b>Example:</b> DZV11-M and CK-DZV11-DB
<b>Base option</b>	Board or peripheral without cables. <b>Example:</b> DZV11-M
<b>Cabinet kit</b>	Unique cable, I/O connection panel insert and bracket hardware required to install the option in a specific cabinet or enclosure. <b>Example:</b> CK-DZV11-DB
<b>External cable</b>	Shielded cable which connects peripherals to the enclosure. These cables must be ordered separately for communication options. The -xx designation in cable model numbers indicates that different length cables or other product variations are available and that the order code corresponding to the desired option must be specified (see Price List).

See Appendix A for conversion of the old option order codes to the new nomenclature.

## Configuring Information

There are five factors to consider when you configure PDP-11 systems:

- **Expansion Space** — the space in a CPU or expansion box to accommodate a specific type of backplane or module. Expansion space refers to physical space, for example, SU (System Unit) or Quad Slots (see CPU Backplane Diagram below).
- **Power Requirements**—the amount of DC current and watts each option requires. The figures for available power are supplied in the configurator worksheet.
- **Bus Loads**—the number of AC and DC busloads drawn by each option. The figures for available bus loads are supplied in the configurator worksheet.
- **Priority**—the order in which options are placed in the backplane can affect system performance. For example, the UDA50 disk storage subsystem control unit is always configured as the last device on the UNIBUS backplane. Note: Each system will be integrated with all modules in the correct prioritized order (not necessarily the order shown in the sample configurator).
- **I/O Connection Panel Insert Space**—space in the I/O Connection Panel (located at the back of the system box) used to carry connectors for communications and peripheral devices. Options vary in the number of connection panel units of space they require. The number of available insert spaces is included in the configurator worksheet.

Once you have selected those options that meet your system requirements, list them in the option column of the configurator, refer to the option chart that lists the power and space requirements mentioned above, and begin subtracting the figures given for each option from the figures provided with the system configuration.

# Introduction

In this sample configuration for a MICRO/PDP-11, a customer has selected 512 KB of additional memory (MSV11-PL), added a floating point processor option (FPF11) and a single line communication device with modem control (DLVE1-DP).

## SYSTEM CONFIGURATOR

CPU BACKPLANE A B C D	OPTION	POWER*						BUS LOADS				PANEL INSERT SIZE					
		@+5V		@+12V		WATTS		AC		DC		SIZE A		SIZE B		SIZE C	
		USED	AVAIL- ABLE	USED	AVAIL- ABLE	USED	AVAIL- ABLE	USED	AVAIL- ABLE	USED	AVAIL- ABLE	USED	AVAIL- ABLE	USED	AVAIL- ABLE	USED	AVAIL- ABLE
			36		6		230		35		20		2		4		
11/23-PLUS CPU	KDF11-BP	4.5	31.5	0.3	5.7	26.1	203.9	2	33	1	19	-	2	1	3		
256 KB PARITY MOS MEMORY	MSV11-PK	3.5	28.0	-	-	17.3	186.6	2	31	1	18	-	2	-	-		
4 LINE MULTIPLEXER	DZV11-CP	1.1	26.9	0.4	5.3	10.2	176.4	4	27	1	17	-	2	1	2		
CONTROLLER FOR RQDX1	RQDX1	7.0	19.9	0.2	5.1	37.4	139.0	3	24	1	16	-	2	-	2		
QUAD OR DUAL	MSV11-PL	3.6	16.3	-	-	18.0	121.0	1	23	-	-	-	2	-	-		
QUAD OR DUAL	FPF-11	7.5	8.8	-	-	37.5	83.5	0	23	-	-	-	2	-	-		
QUAD OR DUAL	DLVE1-DP	1.0	7.8	1.5	3.6	6.8	76.7	2	21	1	15	1	1	-	-		
QUAD OR DUAL																	

\*The total power (+5V and +12V) cannot exceed 230 Watts. If only one Dual Slot is used, insert a bus grant continuity module (G7272) in second Dual Slot.

### Power Requirements

- DC Amps Available** DC current available for system expansion @+5V and @+12V for Q-bus systems and @+5V, @+15V, and @-15V for UNIBUS systems.
- AC Amps Available** AC current available for system expansion @120V within a specific system cabinet for peripheral expansion.
- DC Amps Drawn** DC current drawn from the system @+5V and @+12V for Q-bus systems and @+5V, @+15V, and @-15V for UNIBUS options.
- AC Amps Drawn** AC current drawn by the option @120V or @ 240V.

### Bus Load Requirements

- System Bus Loads Available** The number of electrical loads remaining on the system Q-bus or UNIBUS.
- System Bus Loads Drawn** The number of bus loads the option draws off the Q-bus or UNIBUS.

### Units of Measurement

- |   |                                   |
|---|-----------------------------------|
| b/in = bits per inch (formerly bpi)     | K = 1024                          |
| b/s = bits per second                   | M = 1024 <sup>2</sup> (1,048,576) |
| in/s = inches per second (formerly ips) | KB = Kbytes                       |
| cm/s = centimeters per second           | MB = Mbytes                       |
| l/min = lines per minute                | KB/s = Kbytes per second          |
| l/in = lines per inch                   | MB/s = Mbytes per second          |
| l/cm = lines per centimeter             |                                   |

# Introduction

---

## Definitions

### Space Requirements

<b>SU (System Units)</b>	Definition of space available in BA11-type boxes for mounting backplane(s) to accommodate modules. For example, a BA11-KU(KV) box has five SUs worth of space that could accommodate up to two DD11-DK backplanes and one DD11-CK backplane.
<b>Backplane</b>	Hardware interface containing edge connector slots for insertion of modules. These backplanes allow for the connection of the module to the Bus and to a power supply source. For example: DD11-CK, DD11-DK.
<b>Dual-Height Module</b>	A 13.2 cm x 20.3 cm (5.22 in x 8 in) module with two 36-finger connectors.
<b>Quad-Height Module</b>	A 26.5 cm x 20.3 cm (10.44 in x 8 in) module with four connectors.
<b>Hex-Height Module</b>	A 39.6 cm x 20.3 cm (15.6 in x 8 in) module with six connectors.
<b>Dual Slot</b>	Space in the backplane capable of accepting one dual-height module.
<b>Quad Slot</b>	Space in the backplane capable of accepting one quad-height module on the Q-bus . The slot will also accept one dual-height module and may accept two dual-height modules.
<b>Hex Slot</b>	Space in a UNIBUS backplane capable of accepting a hex-height or quad-height module.
<b>I/O Connection Panel Insert</b>	Space in the plate (I/O Connection Panel) located at the back of Q-bus system boxes and UNIBUS CPU and expander cabinets for simple connection of modules and cables. There are three panel insert sizes for Q-bus options: size A (2.54 cm x 10.1 cm, 1 in x 4 in), size B (6.6 cm x 8.1 cm, 2.6 in x 3.2 in) and size C (10.1 x 10.1 cm, 4 in x 4 in). UNIBUS option panel inserts are in multiples of 5 cm x 10.1 cm (2 in x 4 in) units.

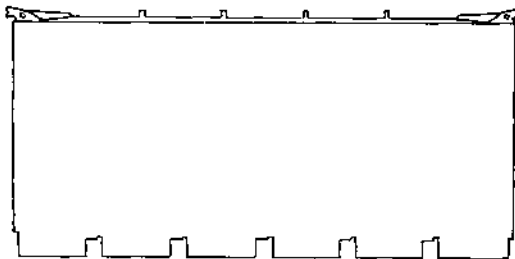

**Hex-Height Module**

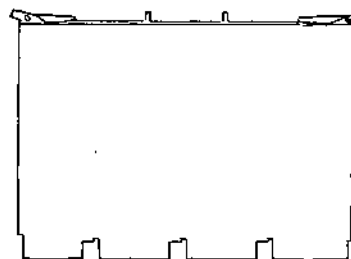

**Quad-Height Module**

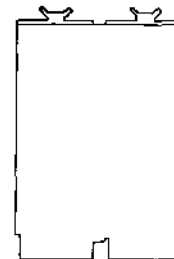

**Dual-Height Module**

# New Cabinet and Cabling

Digital has implemented a design for shielding cabinet and cabling to reduce the potential of electromagnetic interference from computer devices. This new cabling system is made up of three parts:

- First, a shielded CPU enclosure and an internal cable that originates at the option module or controller
- Second, a shielded I/O Connection Panel that joins the internal and external cables and provides the transition between option modules and externally connected devices.
- Third, an external cable that attaches to the peripherals

The I/O Connection Panel (described in Section 1—**Systems**) completes the shielding envelope and provides the filtering necessary to contain potential radio frequency interference within the cabinet. All cables entering or exiting the cabinet must do so via the I/O connector panel.

To simplify the task of connecting Digital and Non-Digital devices to systems in the same way, a wide range of I/O connector panel hardware is offered through the Installed Base Marketing Group.

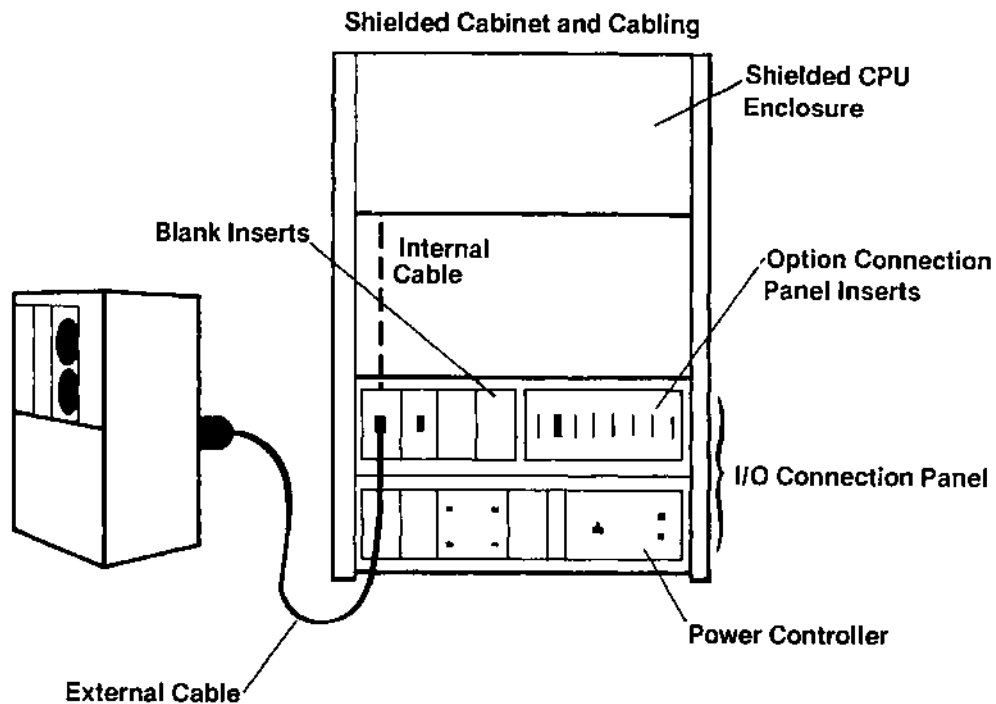

# Supporting Products

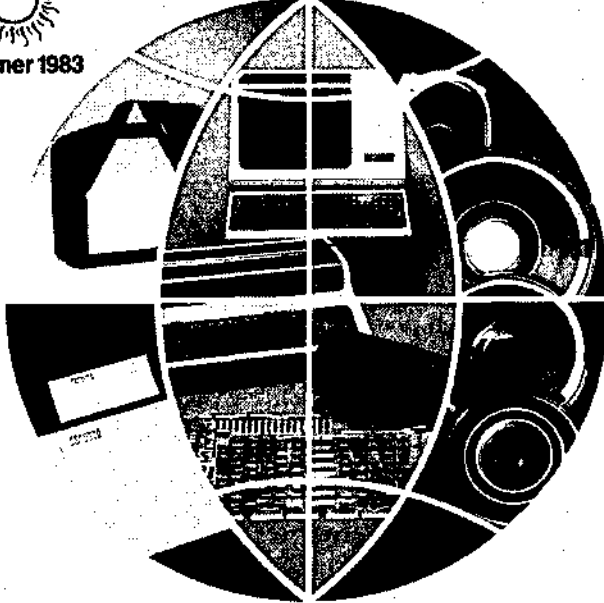

800/258-1710

Summer 1983

Effective July 5, 1983 to October 2, 1983

**Order Direct from  
Digital's Warehouse**

Please specify **JN** when ordering from this catalog.

**OvernightExpress**  
Details Inside Front Cover

To complement your Digital computer system, supporting products such as accessories, supplies, documentation and selected hardware options are available for immediate delivery through the **DECdirect** catalog. Network and personal computing products are also available through DECdirect. Featuring a colorful, informative format, DECdirect makes buying high-quality Digital products easier. For your free copy, in the Continental U.S. and Puerto Rico, call, toll-free, **800-258-1710**. In New Hampshire, Alaska, and Hawaii, call **603-884-6660**. The mailing address is:

Digital Equipment Corporation  
P.O. Box CS2008  
Nashua, New Hampshire 03061

# Supporting Products

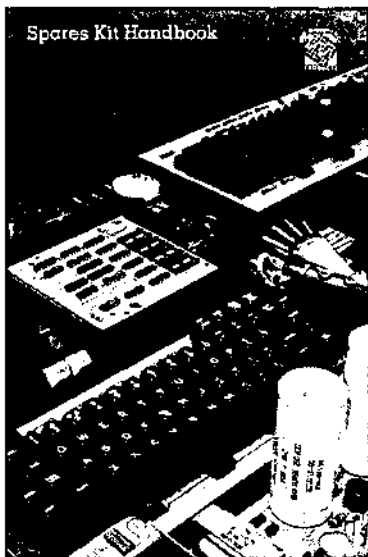

## Spares Kit Handbook

The Spares Kit Handbook is designed to help customers identify the proper kit (or single part) to provide spares for Digital products. It is divided into three easy to use sections including a configurator which alphanumerically lists the hardware options or systems supported by spare parts. This list enables the user to determine which spares support specific options. A brief description of the type of kit and its part number are included.

If you are performing maintenance on your Digital system, you can't afford to be without a copy of this handbook.

## Expansion Products Handbook

Building or adding to your present system? The new Expansion Products Handbook from Digital contains detailed information on:

- Expansion packaging and power hardware
- Backplane hardware
- Connector blocks
- Wire wrap modules
- General purpose interfaces
- Tools and test equipment

No system builder can afford to be without this valuable reference tool. In addition, a separate price list is included. Send for your copy today.

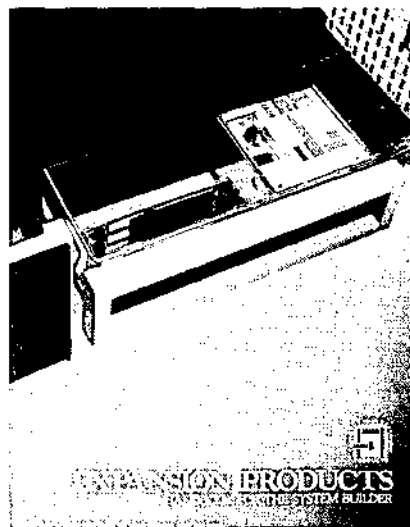

# Supporting Products

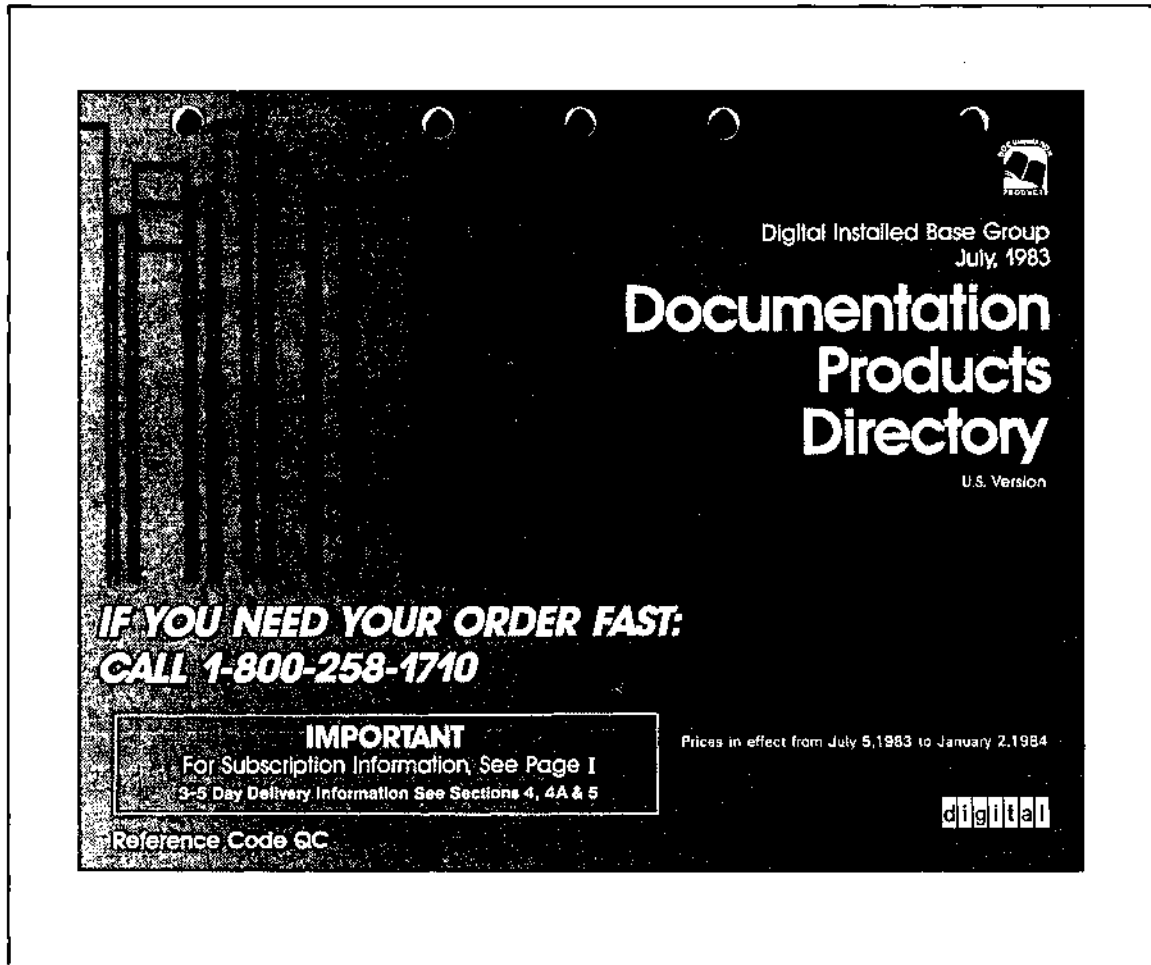

## Documentation Products Directory

Finally! A single reference source of selected Digital hardware and software documentation products. This new directory makes necessary product information readily accessible and it can be used to determine what documentation products are required to support a particular hardware or software option.

### Software Documentation Products

- Software Documentation Kits
- Source Microfiche Kits
- Software Manuals, Handbooks, Reference Cards

### Hardware Documentation Products

- Hardware Manuals
- Maintenance Prints
- Diagnostic Kits

### Other Features

- Ordering/Pricing Information
- Accessories & Supplies Group Discount Policy
- System Software Organization
- Understanding Digital's Software Numbering Scheme
- Glossary of Software Terms and Abbreviations
- Documentation Index by Ordering Part Number
- Documentation Index by Description

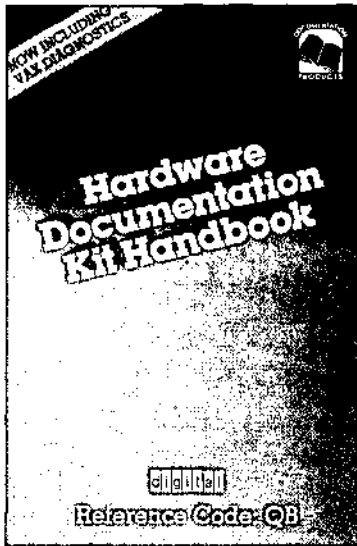

## Hardware Documentation Kit Handbook

DIGITAL's Hardware Documentation Kit Handbook contains listings of documentation kits designed to support Digital's current, high volume products. The book is divided into two sections: Option level products and Systems. A table of contents at the front of the book lists products by their option designation, while the index in the back sorts products by kit number to aid in referencing the various kits. Packaged system matrices have been designed for each processor type.

## Guide to Data Communications

Confused over which communication products to buy? Digital's new guide to Data Communications makes seemingly difficult communications terms understandable enabling you to pick the data communication product that is right for your application. The guide includes detailed information on the following products:

- Acoustic covers
- Modems
- Multiple modems
- Digital's new Intelligent Communication Processor

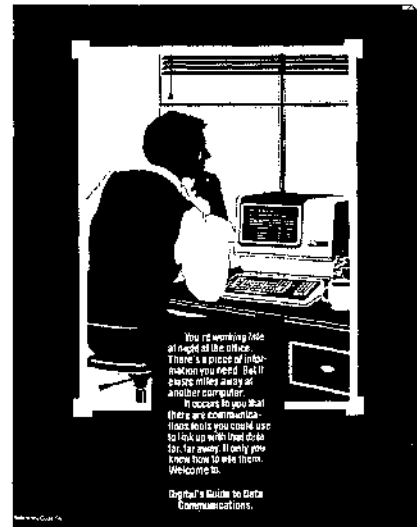

You're working hard  
all night in the office.  
There's a piece of informa-  
tion you need. But it  
isn't miles away or  
another computer.  
It's across the room.  
There are communication  
floors built you can't use  
to talk to with that desk  
top terminal. If only you  
knew how to use them.  
Welcome to.  
Digital's Guide to Data  
Communications.



# Supporting Products

---

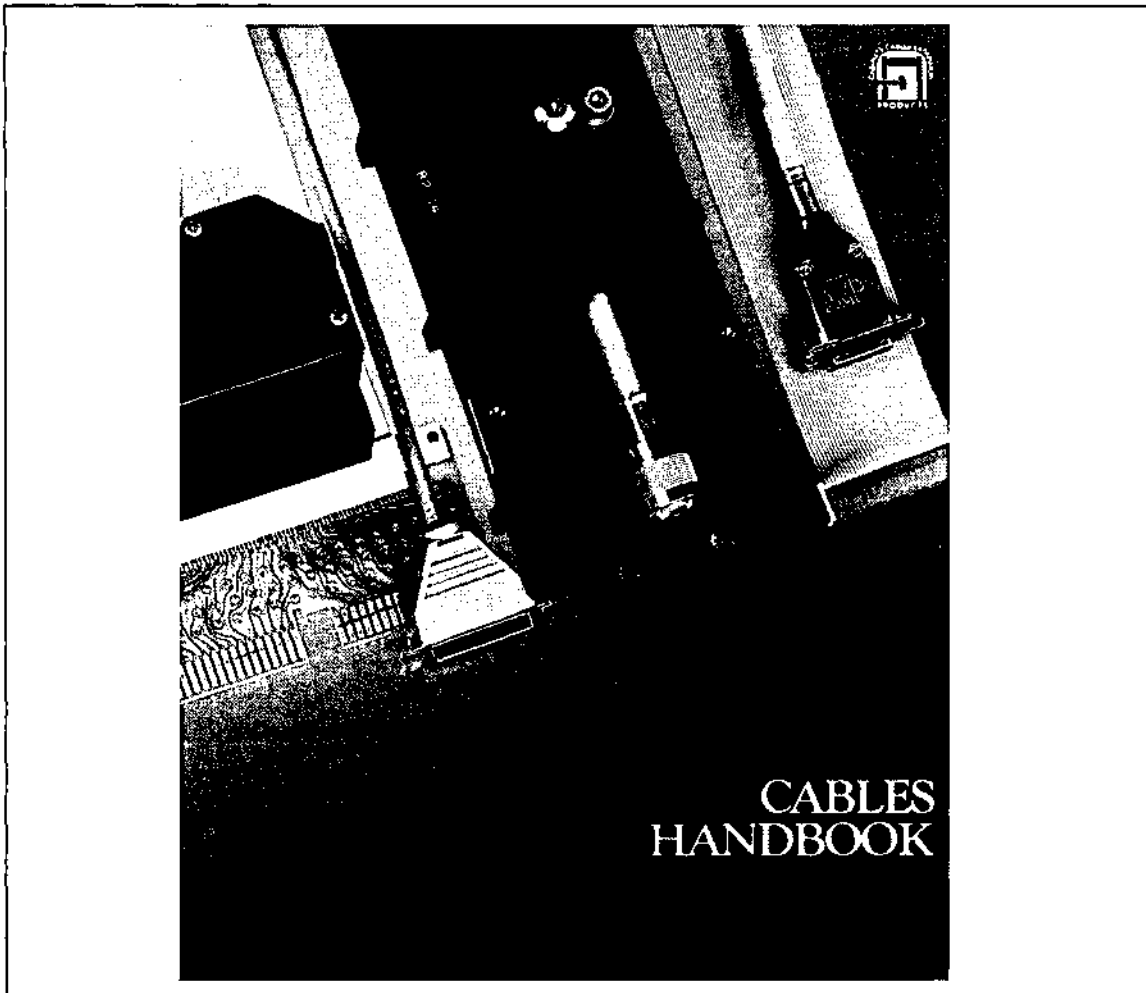

The **Cables Handbook** is published by Digital Equipment Corporation for use by design engineers, consultants, purchasing representatives, sales personnel, and others who design, sell, reconfigure, or maintain computer systems. The handbook is divided into three major sections:

- Ethernet Cables and Physical Channel Hardware
- New Cable Products
- Traditional Cable Products and Connector Kits

Included in each section are cables that are used in external applications, outside of a cabinet or enclosure to remote devices.

Although the cables featured were designed for specific Digital applications, many of the RS232-C and general purpose cables can be used with computer equipment manufactured by other firms. All of the cables featured here are available from Digital's Accessories and Supplies Group.

To request your copy of the new Cables Handbook write:

Digital Equipment Corporation  
Circulation Department MK01/W83  
Continental Boulevard  
Merrimack, NH 03054

# Digital Reference Service

---

## **For Anyone with a Consistent Interest in what Digital Is, Does, and Offers.**

Now, the handiest access ever to information about Digital Equipment Corporation. With the **Digital Reference Service** you have a continuous, reliable and direct source of information on what we are, what we offer, and how we operate. It's all here — our products, applications, and services — compiled by a team of Digital specialists exclusively for our subscribers.

## **Information Tailored to Your Needs**

Whatever your purpose, the Digital Reference Service tells you what you want to know about Digital Equipment Corporation. It provides an overview of Digital's worldwide operations, and provides useful pointers to the sales channels and support organization maintained by Digital. You'll also find a listing of our sales and service offices throughout the world.

Major segments of the Digital Reference Service are devoted to Digital's crossmarket products. Our Reference Service explains what software is available. And which hardware goes with it. It describes all the processors, peripherals, and add-on options that we offer.

For those who need information about products designed with a particular marketplace or application in mind, the Reference Service presents the full range of our market-specific product offerings as well. For the commercial world, it discusses all the products and services specifically tailored for applications in banking, telephone communications, and small-business accounting — to name a few. For the technical environment, it covers such areas as medicine, engineering, research, education, and manufacturing.

We provide information about Digital's office information products, personal computing products, terminals, and the full spectrum of our accessories and supplies. Also described in detail are Digital's customized hardware, microcomputer products, refurbished equipment, and our OEM products and programs.

As a subscriber to the Digital Reference Service, you'll always have instant access to the latest information about our customer training programs and facilities, our hardware and software support services, and our software referral programs. You'll also find descriptions of Digital's special sales channels, retail stores, and Authorized Distributorship Programs.

Also available are price lists for our products and services, keyed to the product descriptions which comprise a major portion of the Digital Reference Service.

## **Designed for Easy Use**

We've organized data by product and by market. Many technical summaries and cross-reference tables highlight important product features and provide quick cross-references between CPUs and operating systems, operating systems and languages, CPUs and supported peripherals, etc. Photographs and charts support detailed product descriptions and provide configuration and environmental guidelines.

A compact master index directs you to the information you want quickly and efficiently. Extensive cross-referencing between volumes automatically leads you to more information about your area of interest. And updating your Digital Reference Service set is easiest of all, with virtually total replacement of the binder contents every quarter.

## **Format Defined by EDP Professionals**

The Digital Reference Service is the culmination of several years of research, many interviews with EDP consultants around the world, and proven success in satisfying subscriber needs.

Whether you're a large user of computers, an OEM, a software house, or an EDP consultant, there is no other source which puts all the facts about the world's largest manufacturer of interactive computers at your fingertips.

You can obtain your Digital Reference Service starter kit at no extra cost with your first-year subscription to our annual update service. It includes a set of handsome binders and the first of four quarterly "full set replacement" packages which you will receive throughout your subscription year. You are also entitled to receive newsletters which provide both product and application-oriented information which develops between quarterly updates. To order your Digital Reference Service starter kit, including full one-year update service, simply fill in the handy order card on the reverse page, and mail it, with your check or purchase order for the amount of \$295\* (\$35\* additional for price lists), to:

Digital Equipment Corporation  
Reference Service (Dept. 12)  
CFO1-2/K21  
200 Baker Avenue  
West Concord, MA 01742

Please provide full subscriber information including name, title, mailstop, and address.

# Digital Reference Service

---

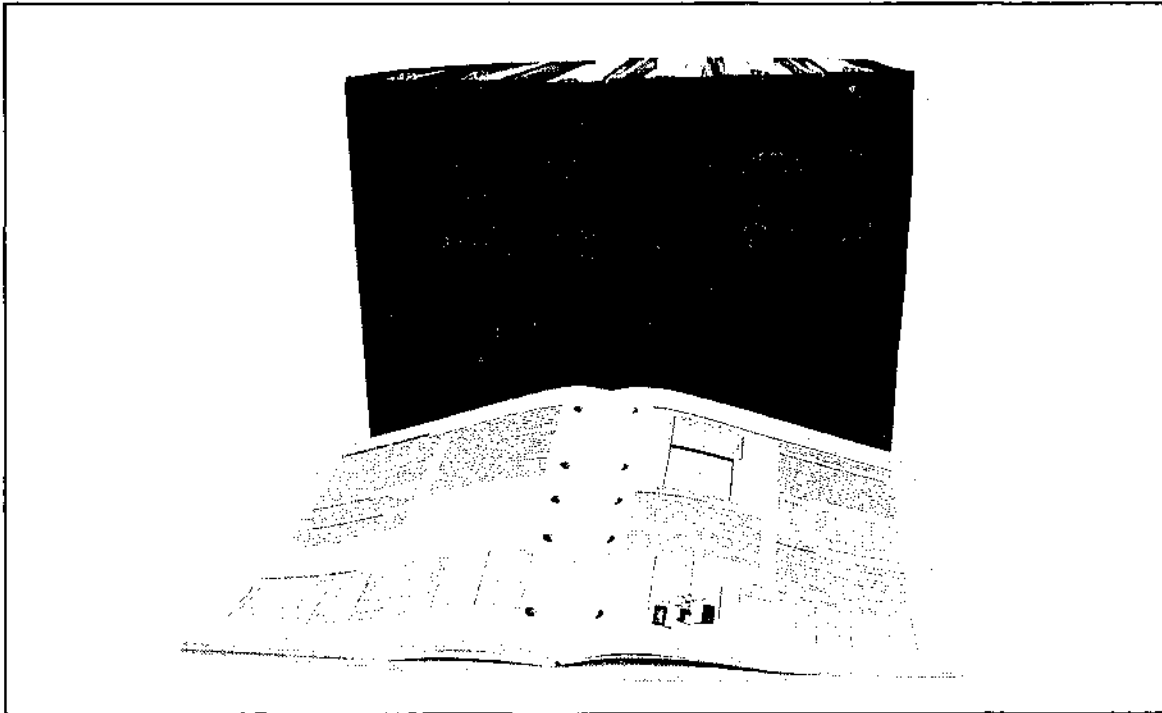

## Your Personal Guide to Digital's Organization, Products and Services

### Guide to DIGITAL

- Organization and Support
- Full Spectrum of Product and Service Offerings
- DIGITAL's OEM Products, Referral Services, Leasing Programs
- Configuration, Environmental, and Compatibility Information

### One-Stop Information Source

- Tailored to Your Needs
- Organized by Product Family, Applications and Performance
- Extensive Product Overview and Cross-reference Tables

### Always Current

- Quarterly, Full-set Replacement Updates
- Compiled Exclusively for Subscribers by DIGITAL Specialists
- Subscriber Newsletters Between Updates

---

### Ordering Information:

I would like to enter \_\_\_\_\_ subscription(s) to the Digital Reference Service and subscribe to the quarterly update service, including the newsletter, at the annual cost of \$295 each. My check or purchase order is enclosed.

Please include in my subscription(s) \_\_\_\_\_ quarterly price lists, for which I have included \$35\* each. My check or purchase order is enclosed.

If this order is for more than one set, please include the name and mailing address of each subscriber. Allow at least 6 weeks for delivery.

\* Above prices valid in the U.S. only and subject to change without notice.

My company's major business is:

- Manufacturing
- Retail/Distribution
- Services Industry
- EDP Consultant/Accounting Firm
- Insurance
- Banking/Finance
- Digital OEM Distributor
- Government/Education
- Computer Mfg./Sales
- Computer Services/SW House

Mr./Mrs./Ms./Miss \_\_\_\_\_

Title \_\_\_\_\_

Firm \_\_\_\_\_

Address \_\_\_\_\_

City \_\_\_\_\_

State \_\_\_\_\_ Zip \_\_\_\_\_ Phone \_\_\_\_\_



# 1 Systems

Digital's PDP-11 systems are based on a compatible set of processors, all using a common VAX-11 instruction set, and all capable of supporting any of seven PDP-11 operating systems. They offer the widest selection of operating systems, languages, data management, communications, and application software in the industry. With over 300,000 systems installed worldwide, the PDP-11 is the most popular minicomputer in history. PDP-11s can also be easily connected to our larger VAX systems, to peripherals and data from other vendors, mainframes, and into an Ethernet.

Using this section in conjunction with the Software section of this catalog it is easy to find the hardware and software that will meet your exact requirements. The system selection chart on the opposite page can be used for a quick comparison of PDP-11 systems.

The Systems section is divided into two parts: **Q-bus systems** and **UNIBUS systems**. The two bus architectures provide similar CPU speed and memory addressability. The major difference between the two is the wide variety of peripheral devices which can be added to the system.

The Q-bus was introduced in 1975. Its simple design permits the implementation of very cost-effective computer systems, such as the **MICRO/PDP-11** and the **PDP-11/23-PLUS**. The largest Digital Q-bus microcomputer systems support have a 10 MB capacity per drive. The fastest networking interface runs at 500 Kbps. The current generation of Q-bus microcomputers is capable of supporting 4 to 12 concurrent users, depending upon the application.



The UNIBUS, the original PDP-11 bus, was introduced in 1970. Applications that require high-speed communications or large disk capacity (up to 456 MB per drive) are typically based on UNIBUS PDP-11 systems, such as the **PDP-11/24** and **PDP-11/44** (many UNIBUS peripherals are also supported on Digital's VAX-11 family of 32-bit superminicomputers). The PDP-11/44 can support up to 48 concurrent users.

All PDP-11 packaged systems include, as minimum components, a CPU, memory, console terminal interface, and a disk subsystem. Most include the PDP-11 Operating System General License which allows you to run any or all Digital PDP-11 operating systems on your computer. Software media, documentation, and support services for each operating system may be ordered as needed. Refer to the **Operating System Ordering Chart** in the Software Section of this catalog. None of these systems include a console terminal. You can select the terminal that best suits your application from the wide variety of video and hardcopy models described in the **Terminals & Printers** section of this catalog.

**CPU Selection Chart**

Processor	Integer Performance (Relative)	Maximum Memory	Mass Storage Devices			Page
			Floppy	Hard Disk	Tape	
MICRO/PDP-11	.4	4 MB	RX50 2 X 0.4 MB	RD51 10 MB RL02 10 MB	TSV05	1-8
PDP-11/23-PLUS	.4	4 MB	RX02 2 X 0.5 MB RX50 2 X 0.4 MB	RL02 10 MB RD51	TSV05	1-12
PDP-11/24	.4	4 MB	RX02 2 X 0.5 MB	RA80 121 MB  RA60 205 MB  RA81 456 MB  RL02 10 MB	TU77   TU80   TE16	1-26
PDP-11/44	1.0	4 MB	RX02 2 X 0.5 MB	RA80 121 MB  RA60 205 MB  RA81 456 MB  RL02 10 MB	TU77   TU80   TE16	1-30

# The Q-bus Family of Multiuser Systems

---



The Q-bus family includes not only the base and packaged systems described here, but a range of chips, single-board computers, and components which are more fully described in the **Components** section.

Two Q-bus multiuser systems are offered: the PDP-11/23-PLUS and the MICRO/PDP-11. Because they utilize the same PDP-11/23-PLUS CPU, they have many features in common. They execute an identical instruction set, support many of the same devices, and support the same memory and performance enhancement options.

The MICRO/PDP-11 is designed for small, multiuser applications where size and cost are of paramount concern. The PDP-11/23-PLUS is more expandable and can handle a wider range of concurrent functions, more communications, and more mass storage. The smallest and lowest priced PDP-11/23-PLUS CPU package is the PDP-11/23-S, in an 8.8 cm (3.5 in) rack-mountable box.

## **Q-bus Computer Features:**

- Physical memory addressing up to 4 MB (backplane space permitting) for improved performance in multiuser applications.
- Optional non-volatile CMOS memory for use in environments where power conditions are uncertain.
- Two asynchronous EIA/CCITT interfaces: one for the console terminal and one for expansion.
- Parity MOS memory expansion in 256 KB or 512 KB increments.
- Optional Commercial Instruction Set chip for faster DIBOL and COBOL-81 program compilation and execution.
- Optional floating point instruction chip or a floating point processor board for faster BASIC and FORTRAN program execution.
- Two CPU operating modes: kernel and user.
- Diagnostic bootstrap which tests memory, CPU, and the console terminal on startup, then boots the system from a designated disk or DECnet line.
- I/O Connection Panel to simplify cable management.

# The Q-bus Family of Multiuser Systems

### MICRO/PDP-11 Selection Chart

Model	Memory	Mass Storage	Enclosure	License Included	Page
11A23-F	256 KB	2 RX50s	Floor/Table	No	1-10
11A23-R	256 KB	2 RX50s	Rackmount	No	1-10
11C23-F	256 KB	RX50/RD51	Floor/Table	No	1-10
11C23-R	256 KB	2 X RX50/RD51	Rackmount	No	1-10
SX-RA500	256 KB	2 X RX50/RD51	Floor/Table	Yes	1-10

### PDP-11/23-PLUS Selection Chart

Model	Memory	Mass Storage	Enclosure	License Included	Page
11/23-BC(BD)	256 KB	No	13.3 cm (5.25 in) Rackmount	No	1-16
11/23-BE(BF)	512 KB	No	13.3 cm (5.25 in) Rackmount	No	1-16
11T23-BK(BL)	512 KB	2 RL02s	H9642 Cabinet	No	1-12
11V23-BE(BJ)	256 KB	1 RX02	H9642 Cabinet	No	1-12
SX-RXMMA	512 KB	2 RL02s	H9642 Cabinet	Yes	1-12

### PDP-11/23-S Selection Chart

Model	Memory	Mass Storage	Enclosure	License Included	Page
11/23-SC(SD)	32 KB	No	8.8 cm (3.5 in) Rackmount	No	1-18
11/23-SE(SF)	64 KB	No	8.8 cm (3.5 in) Rackmount	No	1-18



# The Q-bus Family of Multiuser Computers

---

## Q-bus Options Checklist

The following is a list of system options for the MICRO/PDP-11, the PDP-11/23-PLUS, and the PDP-11/23-S. These options may also be ordered as field upgrades: order a base option and cabinet kit. The options and all ordering details are completely described in Section 2—Options, Section 3—Components, Section 4—Disks and Tapes, and Section 6—Terminals and Printers.

### Processor Options

- KEF11-AA Floating point chip
- KEF11-BB Commercial Instruction Set chip
- FPF11 Floating point processor

### Communication Options

- DLVE1-DP EIA single line interface with full modem control
- DLVJ1-LP 4-line EIA interface
- DLVK1-H EIA to 20mA converter
- DMV11-AP DECnet interface (RS232)
- DMV11-BP DECnet interface (V.35)
- DMV11-CP DECnet interface (Integral Modem)
- DMV11-FP DECnet interface (RS423/449)
- DPV11-AP Synchronous interface (56 KB/s max)
- DUV11-AP Synchronous interface (9.6 KB/s max)
- DZV11-DP 4-line EIA multiplexer (modem control)

### Peripherals

- RLV22-AP Cartridge disk subsystem
- RXV21-EP Floppy disk subsystem 120VAC/60Hz
- RXV21-ES Floppy disk subsystem 120VAC/50Hz
- RXV21-ET Floppy disk subsystem 240VAC/50Hz
- RX50-AA Dual mini-diskette drive
- RX50-R-D Dual mini-diskette drive
- RD51-R-D 10 MB Winchester drive
- RQDX1 RX50/RD51 disk controller
- TUS8-EB Cassette subsystem
- TSV05 Magnetic tape subsystem (PDP-11/23-PLUS only)
- LPV11-AP Lineprinter (64 character set, 300 l/min)
- LPV11-BP Lineprinter (64/96 character set, 300 l/min)
- LPV11-EP Lineprinter (64 character set, 600 l/min)
- LPV11-FP Lineprinter (64/96 character set, 600 l/min)

### Expansion Hardware

- BA11-SE(SF) Expansion box
- BCV2A-03 Bus expansion cable and terminator

### Memory Options

- MCV11-DC 32 KB CMOS memory
- MSV11-PK 256 KB parity memory
- MSV11-PL 512 KB parity memory

### Realtime Options

- AAV11-C Digital to analog converter
- ADV11-C Analog to digital converter
- AXV11-C Analog I/O device
- IEQ11 IEEE converter
- KWV11 Realtime clock
- DRV11-BP DMA parallel interface
- DRV11-JP Four 16-line parallel interfaces
- DRV11-LP Parallel interface

# The Q-bus Family of Multiuser Systems

The products in this catalog are designed for world-wide use. Some products, however, need minor changes to accommodate national languages, local electrical power, etc. Country kits provide a convenient method of bundling the appropriate documentation, labels, diagnostics, and power cords for major geographic areas. The result is that, with the proper country kit, systems can be used world-wide with a minimum of difficulty.

## Country Kits for the MICRO/PDP-11

Country	MICRO/ PDP-11	RQDX1 Controller and Extender	RX50-R-D Externally Mounted Subsystem	RD51-R-D Externally Mounted Subsystem
USA, Canada (English)	-AA	-CA	-DA	-EA
Australia	-AZ	-CZ	-DZ	-EZ
Canada (French)	-AC	-CC	-DC	-EC
Denmark	-AD	-CD	-DD	-ED
Finland	-AF	-CF	-DF	-EF
France	-AP	-CP	-DP	-EP
Germany	-AG	-CG	-DG	-EG
Holland	-AH	-CH	-DH	-EH
Italy	-AI	-CI	-DI	-EI
Norway	-AN	-CN	-DN	-EN
Spain	-AS	-CS	-DS	-ES
Sweden	-AM	-CM	-DM	-EM
Switzerland (French)	-AK	-CK	-DK	-EK
Switzerland (German)	-AL	-CL	-DL	-EL
United Kingdom	-AE	-CE	-DE	-EE

To facilitate international distribution, 15 country kits are offered. A country kit includes a user-friendly checkout diskette, miscellaneous labels, power cable, hardware, and a 7.6 m (25 ft) null modem cable. Order a country kit in the specified language from the Country Kit Chart. The order code is **BQ01** plus the two-letter suffix from the chart. For example, to order a country kit for the RQDX1 for Holland, type **BQ01-CH**.

# MICRO/PDP-11

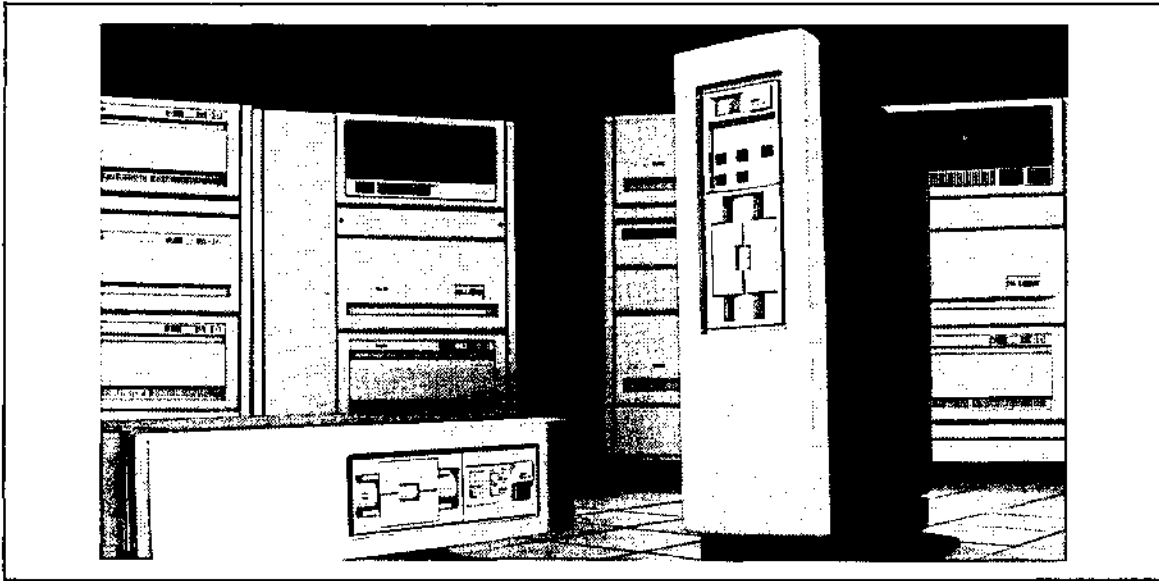

The MICRO/PDP-11 family of small, multiuser computers consists of both floppy-disk and fixed-plus-floppy systems. They are packaged to fit easily under a desk or worktable, on a tabletop, or as a rack mountable box enclosure, and can be expanded to support up to 10 users.

The 13.3 cm (5.25 in) RD51 Winchester disk drive, included in some MICRO/PDP-11 models, has a formatted capacity of 10 MB. The RX50 floppy diskette subsystem, included in all models, accepts two single-sided 13.3 cm (5.25 in) diskettes, each with a capacity of 400 KB (these are the same diskettes used by Digital's Professional series of personal computers, described in the **Personal Computers** Section in this catalog.) The RQDX1 controller handles both the RD51 and the RX50 and performs Direct Memory Access (DMA) block-mode transfers for maximum system efficiency.

The major sub-assemblies —floppy subsystem, system enclosure, processor and memory — are available in component form for system integrators and OEMs.

To facilitate international distribution, 15 country kits are offered. A country kit includes a user-friendly checkout diskette, miscellaneous labels, power cable, hardware, and a 7.6 m (25 ft) null modem cable. Order a country kit in the specified language from the Country Kit Chart on the preceding page. The order code is **BQ01** plus the two-letter suffix from the chart. For example, to order a country kit for the RQDX1 for Holland, type **BQ01-CH**.

## **All Multiuser MICRO/PDP-11s include the standard Q-bus computer features plus:**

- 256 KB parity MOS memory expandable up to 4 MB, backplane space permitting
- One 13.3 cm (5.25 in) dual 400 KB RX50 diskette subsystem (800 KB total)
- Compact BA23 system chassis
- Power cord

## **Some systems also include:**

- PDP-11 Operating System General License
- One 13.3 cm (5.25 in) 10 MB RD51 Winchester disk subsystem
- DZV11 four-line asynchronous multiplexer (for a total of 6 lines)

## System Memory Expansion

This system can be expanded in increments of 256 KB or 512 KB. While memory management and 22-bit addressing can support a maximum of 4 MB of memory, actual memory in the CPU backplane is determined by the number of available quad slots.

## Configuring MICRO/PDP-11 Multiuser Systems

In addition to the routine factors of option power requirements and available backplane slots, the utilization of the I/O Connection Panel must be considered.

## Power Requirements and Bus Loads

Each MICRO/PDP-11 option requires a certain amount of DC current and AC and DC bus loads. To configure a system, subtract the power requirements and bus loads of the options from the available amps at +5V and at +12V and the available AC and DC bus loads (the figures for available power and bus loads are supplied in the configurator worksheet).

## Priority Scheme

The extended Q-bus is designed to support 4 levels of interrupts, 4 through 7. Most options support only level 4 interrupts. Options at the same level have position dependent priority. The CPU is always placed in the first slot followed by the memory module(s). Those options closest to the CPU have the highest positional priority. When configuring options, it is important to consider priority since this can dramatically affect system performance.

## Backplane Slots

The MICRO/PDP-11 has the first three slots configured to accept one option each (quad or dual). The next five slots can accept one quad option or two dual options. When configuring options, make sure that Dual width options get placed adjacent to one another to make efficient use of slot space. If for priority reasons you have a Dual option, followed by a Quad option, a bus grant continuity card (G7272) is included in your country kit to run signals to the Quad option.

Consult the **MICRO/PDP-11 Handbook** for more information on priority schemes.

## I/O Connection Panel Insert Space

The I/O Connection Panel for the MICRO/PDP-11 is a 30.4 cm x 12.7 cm (12 in x 5 in) plate located at the back of the system box. It is used to carry connectors for communication and peripheral cables. These cables connect the computer to terminals and mass storage devices outside of the chassis. The panel is designed to simplify cable management.

MICRO/PDP-11 options have panel inserts which come in two sizes: size A (2.5 cm x 10.1 cm, 1 in x 4 in) and size B (6.6 cm x 8.1 cm, 2.6 in x 3.2 in). The panel has space for two A inserts and four B inserts. An adapter plate is included for converting two B inserts to three A inserts. The MICRO/PDP-11 options consist of two distinct parts: 1) the module, for example, the DZV11 and 2) the cabinet kit, consisting of one size B panel insert with 4 EIA connectors and the cable to connect the module to the panel insert. Mounting hardware is also included.

Refer to the **Option Configuring Charts** at the end of Section 2 and at the end of the **Disks and Tapes** Section for the power requirements, bus loads, backplane and I/O Connection panel insert sizes for each option.

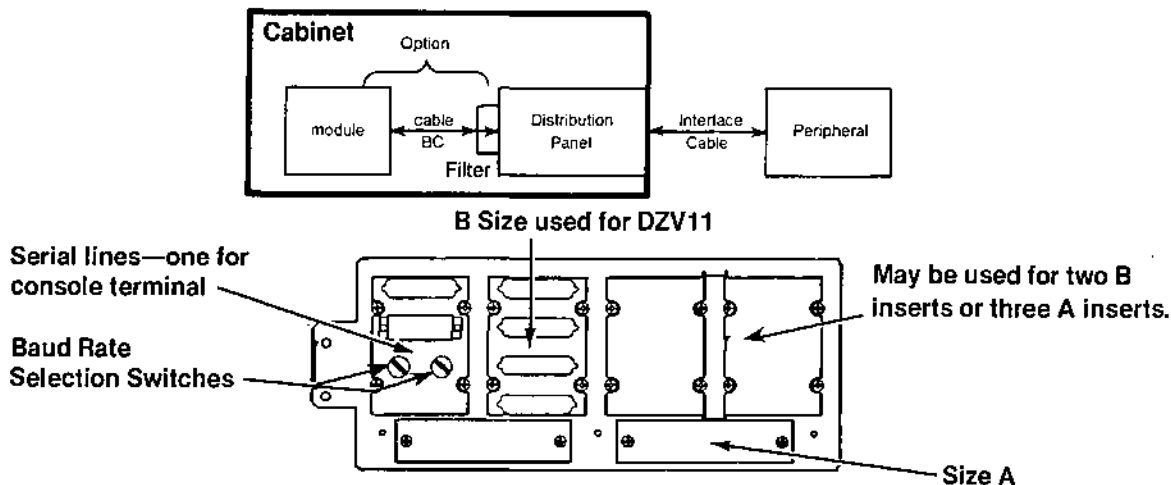

# MICRO/PDP-11

## SX-RA500 SYSTEM CONFIGURATOR

OPTION	POWER						BUS LOADS				PANEL INSERTS			
	@+5V		@+12V		WATTS		AC		DC		SIZE B		SIZE A	
	USED	AVAIL-ABLE	USED	AVAIL-ABLE	USED	AVAIL-ABLE	USED	AVAIL-ABLE	USED	AVAIL-ABLE	USED	AVAIL-ABLE	USED	AVAIL-ABLE
		36		6		230		30		20		4		2
RX/RD	1.2	34.8	3.0	3.0	42	188		30	-	20	-	4	-	2
KDF11-BIE	4.5	30.3	0.3	2.7	26.1	161.9	2	28	1	19	1	3	-	2
MSV11-PK	3.5	26.8	-	-	17.3	144.6	2	26	1	18	-	-	-	2
DZV11-DP	1.1	25.7	0.4	2.3	10.2	134.4	4	22	1	17	1	2	-	2
RQDX1	7.0	18.7	0.2	2.1	37.4	97	3	19	1	16	-	2	-	2

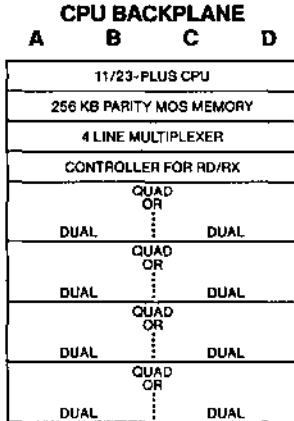

\*The total power (+5V and +12V) cannot exceed 230 Watts. If only one Dual Slot is used, insert a bus grant continuity module (G7272) in second Dual Slot.

### Ordering Information:

- 11A23-F** MICRO/PDP-11 Floor/Table System Base (floppy only). Includes CPU, 256 KB parity MOS memory, RX50 dual diskette subsystem.
- 11A23-R** Same as 11A23-F, but includes rack-mount hardware instead of plastic covers and floor stand.
- 11C23-F** MICRO/PDP-11 Floor/Table System Base. Includes CPU, 256 KB parity memory, RX50 dual diskette subsystem, RD51 Winchester disk subsystem.
- 11C23-R** Same as 11C23-F, but includes rack-mount hardware instead of floorstand and plastic covers.
- SX-RA500-EX** MICRO/PDP-11 Floor/Table Packaged System. Includes the 11C23 features plus a PDP-11 Operating System General License and a DZV11 multiplexer for a total of six terminal ports.
- SX-RA500-FA** Same as SX-RA500-EX but also includes BQ01-AA country kit (USA and English-speaking Canada).

### Site Preparation Specifications:

#### Floor Stand Systems

- Height: 61.25 cm (24.5 in)
- Width: 25 cm (10 in) at base
- Depth: 71.5 cm (28.6 in)
- Weight: 31.8 kg (70 lb)
- Watts: 320
- Receptacles required:  
NEMA #5-15R(120VAC/60Hz), #6-15R(240VAC/50Hz)

#### Table Top Systems

- Height: 15.2 cm (6 in)
- Width: 56.5 cm (22.25 in)
- Depth: 72.4 cm (28.5 in)
- Weight: 32 kg (70 lb)
- Watts: 320
- Receptacles Required:  
NEMA #5-15R (120VAC/60Hz), #6-15R (240VAC/50Hz)

#### Rack Mount Systems

- Height: 13.3 cm (5.25 in)
- Width: 47.5 cm (29 in)
- Depth: 64.8 cm (25.5 in)
- Weight: 24 kg (53 lb)
- Watts: 320
- Receptacles Required:  
NEMA #5-15R (120VAC/60Hz), #6-15R (240VAC/50Hz)

# All computers help you work. This one helps you work as a team.

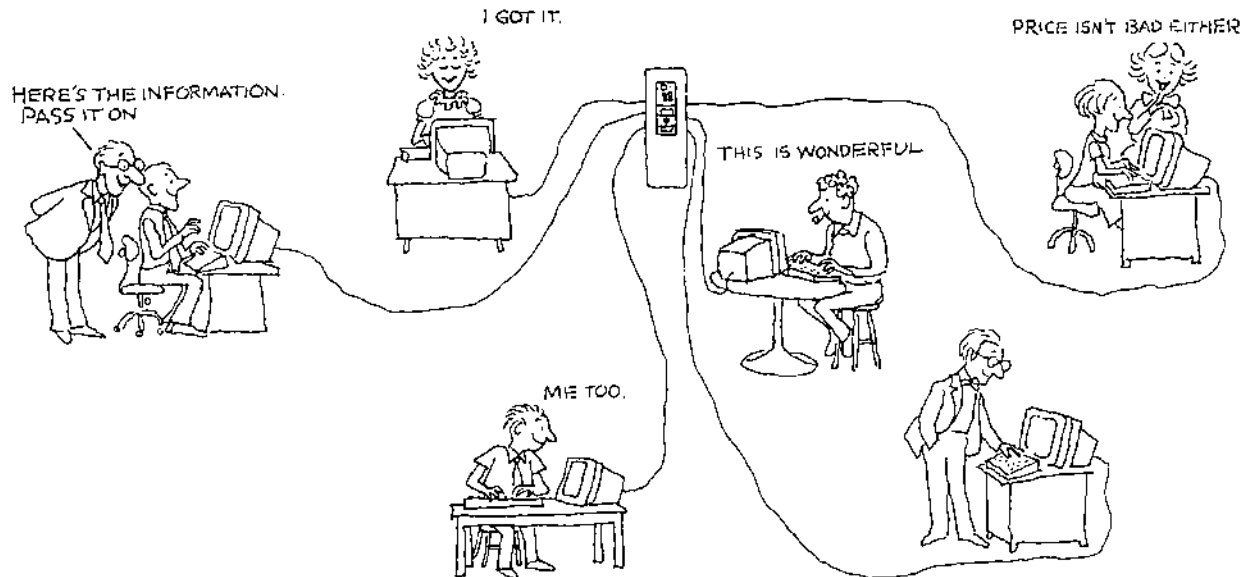

## DIGITAL'S NEW TEAM COMPUTER

Digital Equipment Corporation, the world's second largest computer company, has created the ideal solution for people who work closely together. The new MICRO/PDP-11™ Team Computer system.

This system unites up to 10 people productively and economically. And with over 2,000 software packages to choose from, you can use it for anything from word processing to accounting to engineering.

The idea behind it is ingeniously simple. With the Team Computer, 10 people get their own terminals and their own private files. And because they're all connected to the same computer, they can also share information whenever they need to.

Think about it.

You can share the workload on big projects. Get reports out quicker. Exchange messages faster than phone calls. Since all the information you need is collected in one place, you can pull together more effectively to get the job done.

You can even get information from other Team Computers, personal computers and mainframes.

But the best news is the price. The basic computer starts at \$9,200. Then you just add the terminals and software you need.

And since the computer fits under a desk, you don't even have to worry about making room for it.

Call 1-800-DIGITAL, ext. 650, for our free Team Computer brochure. And turn your work into teamwork.



MICRO/PDP-11 Team Computer

# PDP-11/23-PLUS Multiuser Systems

---

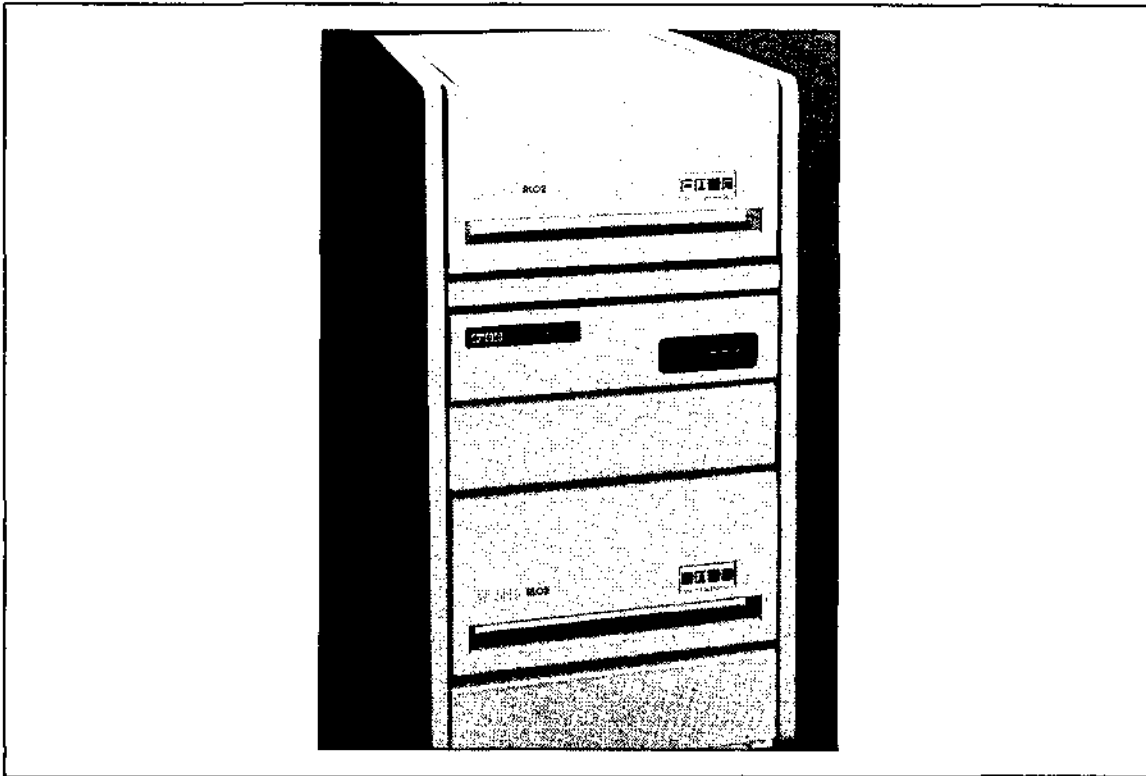

The PDP-11/23-PLUS is a multiuser microcomputer that delivers minicomputer performance by providing memory size and powerful software usually found only on larger, more expensive systems. The PDP-11/23-PLUS is an ideal system for multi-user commercial applications requiring 20-40 MB of disk storage. Its small size, fast response time and large memory make it a good choice for realtime applications such as process control or data acquisition.

**All Multiuser PDP-11/23-PLUS Systems include the standard Q-bus system features plus:**

- 256 KB or 512 KB of parity MOS memory
- One RLV22 disk subsystem (one controller and two 10.4 MB RLO2 removable-cartridge disk drives) OR one RXV21 diskette subsystem (one controller and two 0.5 MB RX02 drives)
- Cabinetry: One 106 cm (41.7 in) high H9642 cabinet
- BC22D-25 cable for console terminal (console terminal not included)

**Ordering Information:**

**Systems**

- |                        |  |
|------------------------|--|
| <b>11T23-BK(BL)</b>    | PDP-11/23-PLUS System Base. 512 KB MOS memory, two RLO2 disks, plus controller. Software license not included.               |
| <b>11V23-BE(BJ)</b>    | PDP-11/23-PLUS System Base. 256 KB MOS memory, one RX02 dual diskette subsystem (1 MB total). Software license not included. |
| <b>SX-RXMMA-EK(EN)</b> | PDP-11/23-PLUS Packaged System. Same as 11T23-BK(BL). Includes the PDP-11 Operating System General License.                  |

# PDP-11/23-PLUS Multiuser Systems

## CPU Cabinet Expansion

There is a 13.3 cm (5.25 in) high by 68 cm (26.8 in) deep area of mounting space available below the CPU box for expansion. This is typically used for a BA11-SE(SF) 8-slot expansion box to accommodate additional memory and communication or realtime options.

The BA11-SE(SF) is a cabinet-mountable expansion box with bezel required for expansion of the PDP-11/23-PLUS system. It houses two fans for side-to-side cooling of the logic modules and H7861 power supply, H9276 backplane with card frame assembly, and an H403B AC input box. The H9276 is a nine-slot Extended Q-bus backplane that provides eight quad slots of mounting space when used as an expansion box. The power supply is rated at 36 amps @ +5V and 5 amps @ +12V.

System expansion is limited to a single BA11-SE(SF). It must be mounted in the CPU cabinet. Customers planning to field install the 120VAC expansion box in the CPU cabinet should purchase a replacement power controller (874-C or 874-D). When the BA11-SE(SF) box is ordered with the system, Digital supplies the appropriate power controller at no extra cost.

**Note:** Cable not included. Order the BCV2A-03 Extended Q-bus cable and expansion assembly for connecting the CPU box to the expansion box.

BA11-SE(SF) EXPANSION BOX

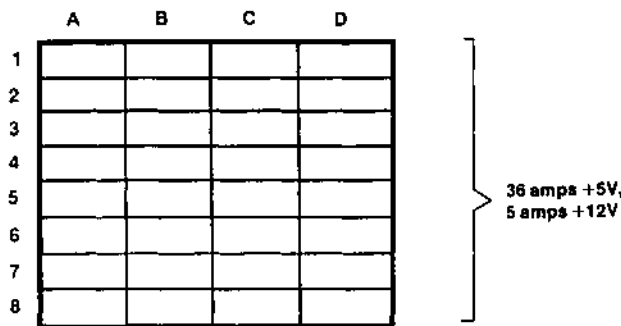

## System Memory Expansion

Memory expansion is available in 256 KB or 512 KB increments for a system maximum of 4 MB, backplane slots permitting.

## System Disk Expansion

Two more RL02 removable-cartridge disk drives may be added to the dual-RL02 systems (11T23 and SX-RXMMMA) for a total of four. An additional H9642 cabinet will be required.

## Configuring PDP-11/23-PLUS Systems

In addition to the routine factors of option power requirements and available backplane slots, the utilization of the I/O Connection Panel must be considered.

Refer to the **Options Configuring Charts** at the end of Section 2 and at the end of the **Disks and Tapes Section** for the power requirements, bus loads, backplane and I/O Connection Panel insert sizes for each option.

## Power Requirements

Each PDP-11/23-PLUS option requires DC current and AC and DC bus loads. To configure a system, subtract the power requirements and bus loads of the options from the available amps at +5V and at +12V and AC loads (the figures for available power are supplied in the configurator worksheet).

## Backplane Slots

The PDP-11/23-PLUS CPU box provides 6 Extended Q-bus Quad slots for expansion. The BA11-SE(SF) expansion box provides an additional 8 quad slots for adding options. The system can be expanded using a BA11-S expansion box.



# PDP-11/23-PLUS

PDP-11/23-PLUS I/O Distribution Panel

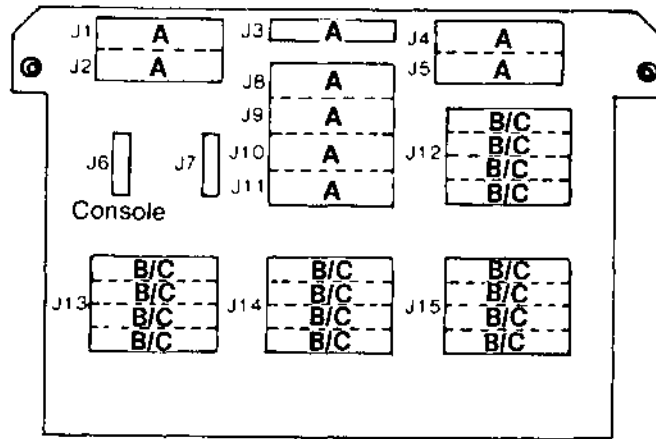

An adapter plate is also included to convert four size A inserts (J8-J11) to one size C insert.

Utilization of I/O Connection Panel

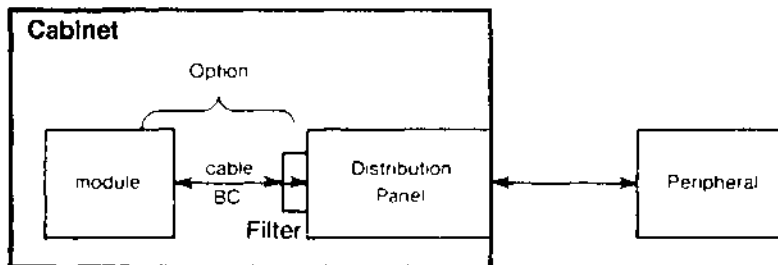

## I/O Connection Panel

The I/O Connection Panel for the PDP-11/23-PLUS is a 28.3 cm (11.5 in) by 44.1 cm (18 in) plate located at the back of the system box. It is used to carry connectors for cables. These cables connect the computer to terminals and mass storage devices outside the CPU box. The panel is designed to simplify cable management.

PDP-11/23-PLUS options have panel inserts which come in two sizes: size A 2.54 cm x 10.1 cm (1 in x 4 in) and size C (4 in x 4 in). The panel has space for nine size A inserts (J1,-2,-3,-4,-5,-8,-9,-10,-11) and four size C inserts (J12,-13,-14,-15). For ease in ordering options, adapters are included with cabinet kits to enable mounting size B (6.6 cm x 8.1 cm, 2.6 in x 3.2 in) in size C (10.1 cm x 10.1 cm, 4 in x 4 in). The two connectors labelled J6 and J7 are for the two serial lines provided with every system. An adapter plate is also included to convert four size A inserts (J8-J11) to one size C insert. The PDP-11/23-PLUS options consist of two distinct parts: 1) the module, for example, the DZV11 and 2) the cabinet kit, consisting of the panel insert, in this case one size B with 4 EIA connectors and the cable to connect the module to the panel insert. Mounting hardware is also included. (See diagram below.) The Configuring worksheet has space provided for figuring available panel insert space.

## SX-RXMMA AND 11T23 SYSTEM CONFIGURATOR

CPU BOX A    B    C    D				POWER				BUS LOADS				PANEL INSERTS				
				@+5V		@+12V		DC		AC		SIZE A		SIZE C		
				USED	AVAIL- ABLE	USED	AVAIL- ABLE	USED	AVAIL- ABLE	USED	AVAIL- ABLE	USED	AVAIL- ABLE	USED	AVAIL- ABLE	
					36.0		5.0		20		32		9		4	
11/23-PLUS CPU				KDF11-B	4.5	31.5	.3	4.7	1	19	2	30	0	9	0	4
512 KB PARITY MOS MEMORY				MSV11-PL	3.6	27.9	0	4.7	1	18	2	28	0	9	0	4
CONTROLLER FOR RLO2 DISK DRIVES				RLV12	5.0	22.9	.1	4.6	1	17	3	25	0	9	0	4
EXTENDED LSI-11 QUAD SLOT																
EXTENDED LSI-11 QUAD SLOT																
EXTENDED LSI-11 QUAD SLOT																
EXTENDED LSI-11 QUAD SLOT																
EXTENDED LSI-11 QUAD SLOT																
EXTENDED LSI-11 QUAD SLOT																

## 11V23-BE SYSTEM CONFIGURATOR

CPU BOX A    B    C    D				POWER				BUS LOADS				PANEL INSERTS				
				@+5V		@+12V		DC		AC		SIZE A		SIZE C		
				USED	AVAIL- ABLE	USED	AVAIL- ABLE	USED	AVAIL- ABLE	USED	AVAIL- ABLE	USED	AVAIL- ABLE	USED	AVAIL- ABLE	
					36.0		5.0		20		32		9		4	
11/23-PLUS CPU				KDF11-B	4.5	31.5	.3	4.7	1	19	2	30	0	9	0	4
256 KB PARITY MOS MEMORY				MSV11-PK	3.5	28.0	0	4.7	1	18	2	28	0	9	0	4
CONTROLLER FOR RX02				RXV21	1.8	26.2	0	4.7	1	17	3	25	0	9	0	4
EXTENDED LSI-11 QUAD SLOT																
EXTENDED LSI-11 QUAD SLOT																
EXTENDED LSI-11 QUAD SLOT																
EXTENDED LSI-11 QUAD SLOT																
EXTENDED LSI-11 QUAD SLOT																
EXTENDED LSI-11 QUAD SLOT																

### Site Preparation Specifications: 11T23 and SX-RXMMA

- Height: 106 cm (41.7 in)
- Width: 54 cm (21.3 in)
- Depth: 76.2 cm (30 in)
- Rear Door Clearance: 48.3 cm (19 in)
- Weight: 170.3 kg (375 lb)
- Watts: 840
- Btu/hr: 2864
- Receptacles:  
NEMA #5-15R (120VAC/60Hz)  
#6-15R (240VAC/50Hz)

### Site Preparation Specifications: 11V23

- Height: 106 cm (41.7 in)
- Width: 54 cm (21.3 in)
- Depth: 76.2 cm (30 in)
- Rear Door Clearance: 48.3 cm (19 in)
- Weight: 139.6 kg (288 lb)
- Watts: 380
- Btu/hr: 1297
- Receptacles:  
NEMA #5-15R (120VAC/60Hz),  
#6-15R (240VAC/50Hz)

# PDP-11/23-PLUS Rack-mountable Computer

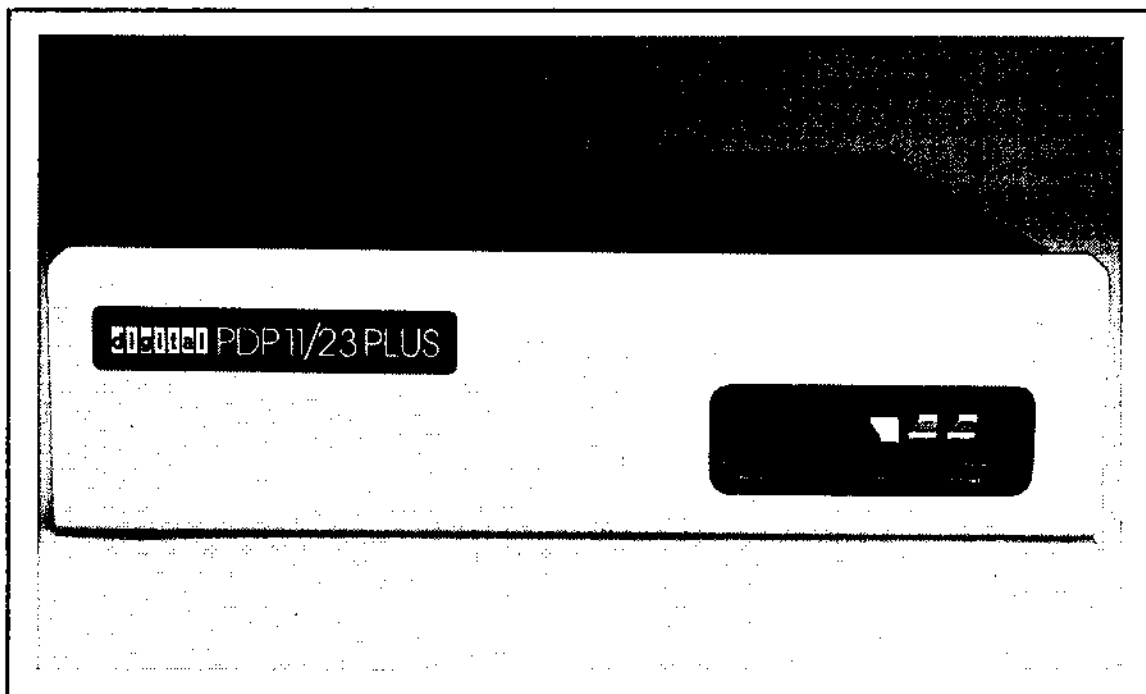

The PDP-11/23-PLUS is available in two rack-mountable variations: a standard 13.3 cm (5.25 in) PDP-11/23-PLUS and an 8.8 cm (3.5 in) PDP-11/23-S.

The PDP-11/23-PLUS rack-mountable CPU box includes:

- 11/23-PLUS CPU
- 256 or 512 KB memory
- Two serial line units
- Line frequency clock
- Boot and diagnostic ROMs
- Nine slot backplane (seven unused slots)

## Site Preparation Specifications:

- Height: 13.3 cm (5.25 in)
- Width: 48.3 cm (19 in)
- Depth: 68 cm (26.8 in)
- Weight: 20 kg (45 lb)
- Watts: 550
- Btu/hr: 1877
- Receptacles:
  - NEMA #5-15R (120VAC/60Hz),
  - #6-15R (240VAC/50Hz)

## Ordering Information:

11/23-BC(BD)	CPU with 256 KB memory
11/23-BE(BF)	CPU with 512 KB memory
H349	I/O Connection Panel (must be ordered separately)

# PDP-11/23-PLUS Rack-mountable Computer

## 11/23-BC(BD) SYSTEM CONFIGURATOR

CPU BOX A. B C D	OPTION	POWER*				BUS LOADS				PANEL INSERT SIZE			
		@+5V		@+12V		DC		AC		SIZE A		SIZE C	
		USED	AVAIL- ABLE	USED	AVAIL- ABLE	USED	AVAIL- ABLE	USED	AVAIL- ABLE	USED	AVAIL- ABLE	USED	AVAIL- ABLE
			36.0		5.0		20		32		0		0
11/23-PLUS CPU	KDF11-B	4.5	31.5	.3	4.7	1	19	2	30	0	0	0	0
256 KB PARITY MQS MEMORY	MSV11-PK	3.5	28.0	0	4.7	1	18	2	28	0	0	0	0
EXTENDED Q-BUS QUAD SLOT													
EXTENDED Q-BUS QUAD SLOT													
EXTENDED Q-BUS QUAD SLOT													
EXTENDED Q-BUS QUAD SLOT													
EXTENDED Q-BUS QUAD SLOT													
EXTENDED Q-BUS QUAD SLOT													
EXTENDED Q-BUS QUAD SLOT													

# PDP-11/23-S Rack-mountable Computer

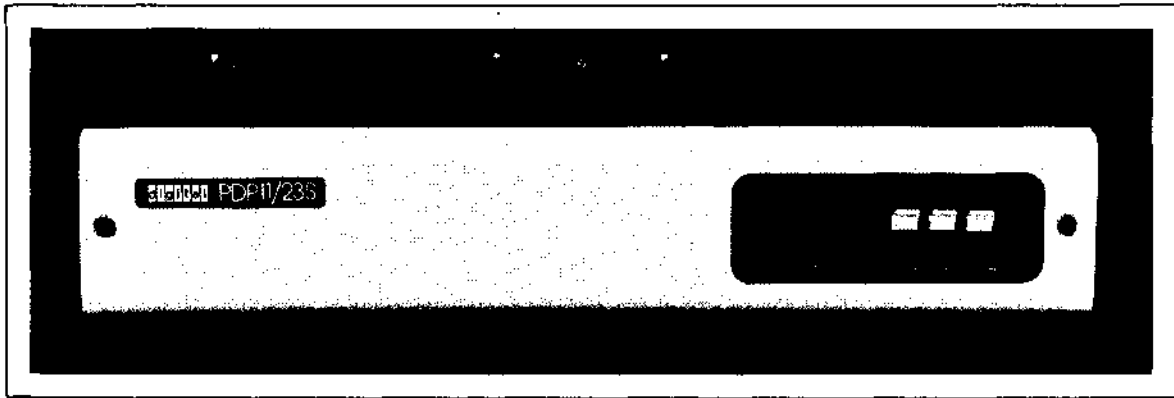

The PDP-11/23-S is an 8.8 cm (3.5 in) high, rack-mountable processor offered in two versions, one with NMOS RAM memory, the other with non-volatile CMOS RAM memory. The I/O Connection panel (H3012) for this model accepts the same system options as the MICRO/PDP-11 and the PDP-11/23-PLUS. The PDP-11/23-S is not orderable in a system configuration.

The PDP-11/23-PLUS includes:

- 11/23-PLUS CPU
- 64 KB NMOS RAM or 32KB CMOS RAM memory
- Two serial line units
- Line frequency clock
- 18-bit addressing
- Space for 5 dual-height Q-bus options
- I/O Connection Panel with removable templates

## Site Preparation Specifications:

- Height: 8.9 cm (3.5 in)
- Width: 48.3 cm (19 in)
- Depth: 38.1 cm (15 in)
- Weight: 18.1 kg (40 lb)
- Watts: 150 (typical)
- Btu/hr: 510
- Receptacles:
  - NEMA #5-15R (120VAC/60Hz),
  - #6-15R (240VAC/50Hz)

## Ordering Information:

- 11/23-SC(SD) CPU with 32 KB CMOS memory  
11/23-SE(SF) CPU with 64 KB NMOS memory

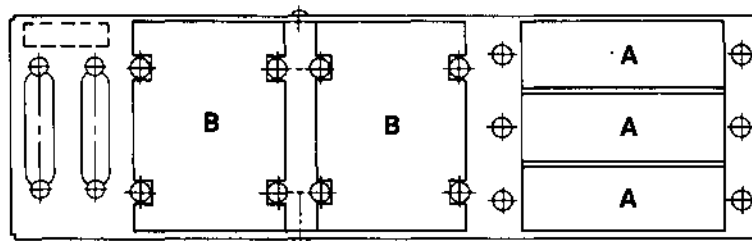

PDP-11/23-S I/O Connection Panel with Blank Inserts

# PDP-11/23-S Rackmountable Computer

## 11/23-SC(SD) SYSTEM CONFIGURATOR

SLOT SELECTION	OPTION	SIZE	POWER*				BUS LOAD				PANEL INSERTS			
			+5		+12		DC		AC		SIZE A		SIZE B	
			U	A	U	A	U	A	U	A	U	A	U	A
#1 A/B/C/D	KDF11-B	QUAD	4.5	18	.3	3.2	1	19	2	18	0	6	0	3
2 C/D	MCV11-DC	DUAL	1.2	11.3	0	3.2	1	18	2	16	0	6	0	3
2 A/B														
3 A/B														
3 C/D														
4 C/D														
4 A/B														

\*Not to exceed 110 Watts.

## 11/23-SE(SF) SYSTEM CONFIGURATOR

SLOT SELECTION	OPTION	SIZE	POWER*				BUS LOAD				PANEL INSERTS			
			+5		+12		DC		AC		SIZE A		SIZE B	
			U	A	U	A	U	A	U	A	U	A	U	A
#1 A/B/C/D	KDF11-B	QUAD	4.5	13.5	.3	3.2	1	19	2	18	0	6	0	3
2 C/D	MSV11-DD	DUAL	1.7	11.8	.4	2.8	1	18	2	16	0	6	0	3
2 A/B														
3 A/B														
3 C/D														
4 C/D														
4 A/B														

\*Not to exceed 110 Watts.

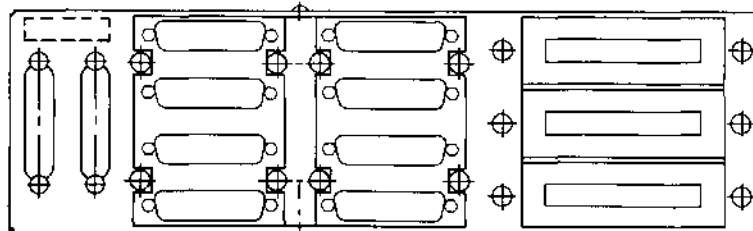

**PDP-11/23-S I/O Connection Panel with Panel Insert Units**

# The PDP-11 UNIBUS Family of Computers

---



Today Digital offers the PDP-11/24 and the PDP-11/44, based on its highly successful UNIBUS technology. Together these products provide a wide range of minicomputer solutions from small dedicated control, communication, and computational applications, to larger, multi-user business and scientific timesharing systems. The UNIBUS is a bidirectional, asynchronous interconnect that links these versatile processors with the industry's most comprehensive set of mass storage systems and communications interfaces. It provides the configuration flexibility and growth capacity that make these processors ideal solutions for a broad spectrum of applications.

The PDP-11/24 and the PDP-11/44 execute a common instruction set, run under the control of any of Digital's PDP-11 operating systems, and make available the problem solving power of Digital's proven languages, data management, communications, and networking products.

Both the PDP-11/24 and the PDP-11/44:

- Provide high performance Floating Point and Commercial Instruction Set processor options.
- Offer memory expansion up to 4 MB for enhanced multi-user and realtime performance.
- Permit memory expansion in 1 MB increments.
- Support the microprocessor-based DSA (Digital Storage Architecture) for high density mass storage and reduced CPU overhead.
- Support the microprocessor-based network communications options for comprehensive system configuration and resource sharing.
- Offer enhanced system reliability and availability through self-diagnostics and power monitoring, and optional battery backup and auto restart.
- Include ASCII console logic for system control/debugging with optional console terminal.
- Include two EIA/CCITT serial interfaces, one for the console terminal and one for expansion.
- Provide compatibility with existing UNIBUS peripheral devices for smooth system upgrades.
- Offer unmatched configuration flexibility and system growth capacity.

The PDP-11/24 was designed to provide the basis for compact, low cost application solutions. Its features include a single board CPU with space for optional Commercial Instruction Set and Floating Point Processor chips. It offers an optional hardware Floating Point Processor that delivers up to 6 times the performance of the FPP chip. The PDP-11/24 provides sophisticated memory management coupled with the extended memory addressing option, the KT24, that provides 4 MB memory addressing. These features combine to give the PDP-11/24 capabilities that were previously only available on larger, more powerful PDP-11s.

# UNIBUS Family of Computers

The PDP-11/44 was designed to provide a higher level of performance and greater total system capacity, at a moderate price. It delivers roughly twice the performance of the PDP-11/24, and it is ideally suited for larger, multi-user, departmental level applications. The PDP-11/44's unique features include an 8 KB high speed cache memory, standard 22-bit extended memory addressing, separate Instruction and Data address space support and three operating modes. In addition, the PDP-11/44 offers high performance hardware Commercial Instruction Set and Floating Point Processor options. The PDP-11/44 provides the kind of configuration flexibility and growth capacity that is characteristic of all PDP-11s.

The PDP-11/24 and PDP-11/44 are available in four levels of integration:

- The **Rack-mountable Computers** provide significant expansion space and memory expansion up to a maximum of 4 MB.
- The cabinet-mounted **Kernel Computers** provide a base for OEM system integration.
- The **System Building Blocks** allow the choice of system and load devices from a variety of disk and tape subsystems and include the PDP-11 Operating System General License.
- The **Packaged Systems** include all the necessary hardware and software components (with the exception of the console terminal) for a complete system.

The standard features of all PDP-11/24s and PDP-11/44s are highlighted below. More detailed information is included in the individual system descriptions.

## PDP-11/24 Computer Features:

- Single board CPU with power supply
- 1 MB ECC MOS memory
- Memory expansion up to 4 MB, in 1 MB increments
- Sophisticated memory management
- Two operating modes: kernel and user
- Integral bootstrap with diagnostics
- ASCII console logic
- Line frequency clock
- Two serial line asynchronous EIA/CCITT interfaces: one for the console terminal and one for expansion
- Nine-slot CPU backplane
- 13.3 cm (5.25 in) or 26.6 cm (10.5 in) box

## PDP-11/44 Computer Features:

- High performance CPU with power supply
- 8 KB high-speed cache memory
- 1 MB ECC MOS memory
- Memory expansion up to 4 MB, in 1 MB increments
- Sophisticated memory management unit
- Three operating modes: kernel, supervisor and user
- Separate Instruction and Data address space
- ASCII console logic
- Integral bootstrap with diagnostics
- Line frequency clock
- Two serial line asynchronous EIA/CCITT interfaces: one for the console terminal and one for expansion
- DC voltage monitor
- Fourteen-slot CPU backplane
- 26.6 cm (10.5 in) box



# UNIBUS Family of Computers

---

**PDP-11/24 Selection Chart**

Model	Memory	Mass Storage Included	Enclosure	License Included	Page
11/24-CC(CD)	1 MB	None	13.3 cm (5.25 in) Rackmount	No	1-26
11/24-DC(DD)	1 MB	None	26.6 cm (10.5 in) Rackmount	No	1-28
11X24-FA(FB)	1 MB	None	H9642 Cabinet	No	1-32
SX-FX100-EK(EN)	1 MB	None	H9642 Cabinet	Yes	1-36
SX-FX200-EK(EN)	1 MB	None	H9645 Cabinet	Yes	1-36
SX-FXGMB-EK(EN)	1 MB	RA80/RL02	H9645 Cabinet	Yes	1-42
SX-FXMMB-EK(EN)	1 MB	(2) RL02s	H9645 Cabinet	Yes	1-40

**PDP-11/44 Selection Chart**

Model	Memory	Mass Storage Included	Enclosure	License Included	Page
11/44-DA(DB)	1 MB	None	26.6 cm (10.5 in) Rackmount	No	1-30
11X44-FA(FB)	1 MB	None	H9642 Cabinet	No	1-34
SX-40100-EK(EN)	1 MB	None	H9642 Cabinet	Yes	1-38
SX-40200-EK(EN)	1 MB	None	H9645 Cabinet	Yes	1-38
SX-40GMB-EK(EN)	1 MB	RA80/RL02	H9645 Cabinet	Yes	1-46
SX-40MMB-EK(EN)	1 MB	(2) RL02s	H9645 Cabinet	Yes	1-44

# UNIBUS Family of Computers

## UNIBUS Options Checklist

The following is a list of system options for the PDP-11/24 and PDP-11/44 systems. These options may also be ordered as field upgrades; order a base option and cabinet kit. The options and all ordering details are described in Section 2—Options, and Section 4—Disks and Tapes.

### PDP-11/24 Processor Options

- KEF11-AA Floating Point Chip
- KEF11-BB Commercial Instruction Set
- FPF11 Floating Point Processor

### PDP-11/44 Processor Options

- KE44-A Commercial Instruction Set
- FP11-F Floating Point Processor

### PDP-11/24 Memory Options

- MS11-PB 1 MB ECC MOS memory
- KT24 Physical Address Extension Module

### PDP-11/44 Memory Options

- MS11-PB 1 MB ECC MOS memory

### Communication Options

- DL11-AP EIA interface (modem control)
- DL11-HP 20mA serial line interface
- DL11-DP EIA/CCITT serial line interface (RS232-CR, modem control)
- DZ11-DP 8-line asynchronous EIA multiplexer (modem control)
- DZ11-HP 8-line asynchronous 20mA multiplexer
- DH11-AP 16-line asynchronous DMA multiplexer (modem control)
- DH11-DP 16-line asynchronous 20mA multiplexer
- DUP11-AP Full- or half-duplex synchronous interface (modem control)
- DMR11-AP DECnet point-to-point interface (RS232-C)
- DMR11-FP DECnet point-to-point interface (RS423/CCITT V.24)
- DMR11-BP DECnet point-to-point interface (V.35/DDS)
- DMR11-CP DECnet point-to-point interface (Integral Modem)
- DMR11-EP DECnet point-to-point interface (RS422/CCITT V.24)
- DMP11-AP DECnet multi-point interface (RS232-C)
- DMP11-FP DECnet multi-point interface (RS423/CCITT V.24)

- DMP11-BP DECnet multi-point interface (V.35/DDS)
- DMP11-CP DECnet multi-point interface (Integral Modem)
- DMP11-EP DECnet multi-point interface (RS422/CCITT V.24)
- PCL11-B Multipoint parallel interface
- KMS11-BD 8-line synchronous communication front-end processor
- DEUNA-AA Ethernet communication controller

### Realtime I/O Options

- ADK11-KT AD11-K converter and KW11-K realtime clock
- AM11-K 48-channel(single-ended) or 24-channel (differential) expander switch
- DR11-C Parallel interface
- DR11-KT Parallel interface
- DR11-WP General purpose DMA parallel interface
- DRS11 Digital output
- DRU11 Buffered DMA parallel interface
- DSS11 Digital input
- IEC11 IEEE interface
- IEV11 IEEE interface
- KW11-K Dual programmable realtime clock
- KW11-P Programmable realtime clock

### Peripherals

- RUA80-AA 121 MB fixed Winchester disk
- RUA81-AA 456 MB fixed Winchester disk
- RUA60-CA 205 MB removable disk
- RL211-AK 10 MB cartridge disk
- RX211-BK Dual floppy diskette subsystem
- TU80-AA Magnetic tape (25/100 in/s)
- TJE16-AA Magnetic tape (45 in/s)
- TJU77-AB Magnetic tape (125 in/s)
- TU58-DA Cartridge tape (30 in/s)

# UNIBUS Family of Computers

---

## Configuring UNIBUS Systems

### I/O Connector Panel

The I/O Connector Panel (IOCP) provides the transition between internal cabling and the external shielded cabling to peripheral devices. All cables that enter or exit cabinets must pass through the IOCP.

The I/O panel system is comprised of three components: an internal cable that originates at the option module or controller, a shielded external cable that attaches the I/O panel to the peripheral, and an I/O Connector Panel Insert that mounts in the IOCP and joins the internal and external cables. With the IOCP, the Connector Insert provides the shielding and filtering necessary to contain potential interference within the cabinet.

The I/O panel is provided as part of the CPU system cabinet. The Connector Insert and internal cable are provided with the specific option.

The capacity of the I/O panel varies with the cabinet and CPU type. The type and style of inserts varies depending on the amount and type of connectors required by the option. Each I/O panel accepts multiple inserts. Unused I/O panel space is filled with blank inserts to maintain shielding continuity.

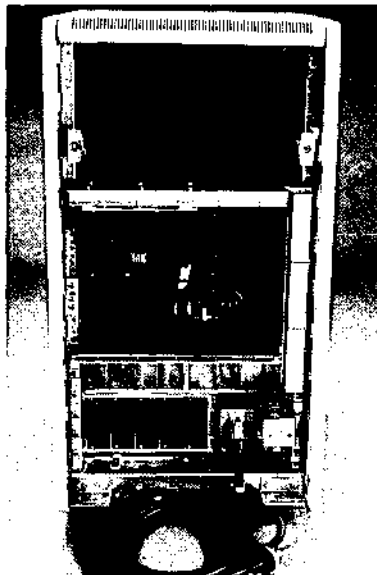

**Horizontal I/O Connection Panel**

Standard on H9642 CPU Cabinets

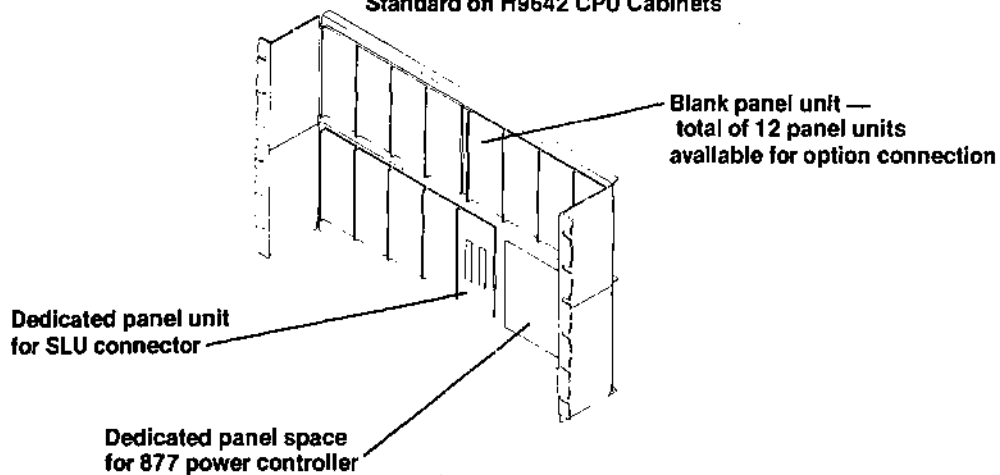

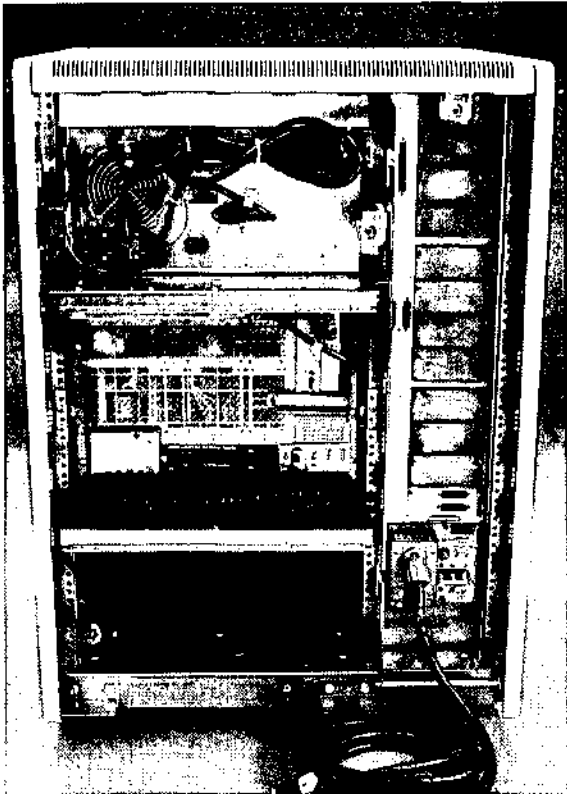

**Vertical I/O Connection Panel**  
Standard on H9645 CPU Cabinets

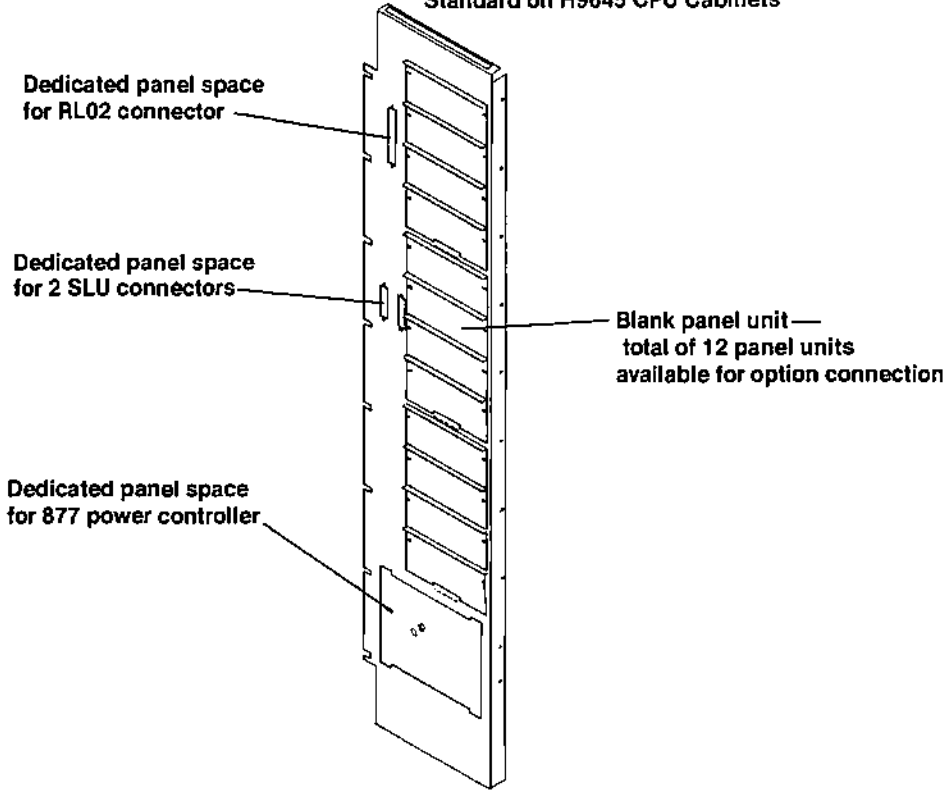

# PDP-11/24 Rack-mountable Computers

---

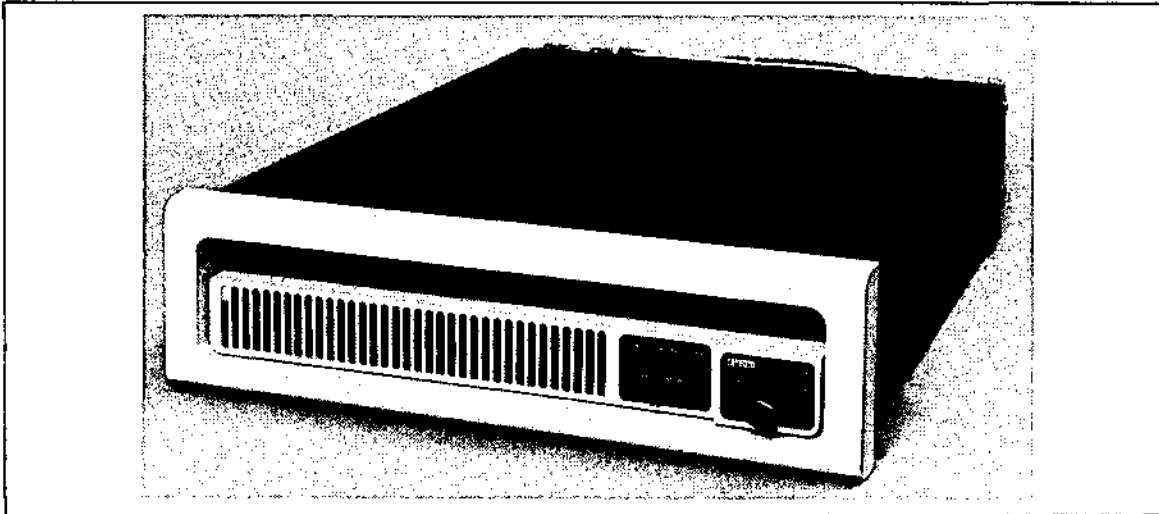

## PDP-11/24 5.25 inch Rack-mountable Computer

The PDP-11/24 is offered in a 13.3 cm (5.25 in) industry-standard, rack-mountable variation. This compact enclosure accommodates a maximum of 1 MB of memory.

### 11/24-CC(CD)

The 11/24-CC(CD) includes the following:

- PDP-11/24 CPU and power supply
- KT24 Physical Address Extension (PAX) module
- 1 MB ECC MOS memory (MS11-PB)
- 13.3 cm (5.25 in) rack-mountable box

### Site Preparation Specifications:

- Height: 13.3 cm (5.25 in)
- Width: 42.2 cm (16.6 in)
- Depth: 69 cm (26 in)
- Weight: 20 kg (45 lb)
- Watts: 176 as configured  
500 in maximum configuration
- Btu/hr: 598/1700
- Receptacles:  
NEMA #5-15R (120VAC/60Hz), #6-15R(240VAC/  
50Hz)

# PDP-11/24 Rack-mountable Computers

**11/24-CC(CD) SYSTEM CONFIGURATOR**

CPU BOX		OPTION	DC POWER						BUS LOADS	
			@ + 5V		@ + 15V		@ - 15V		USED	AVAIL-ABLE
			USED	AVAIL-ABLE	USED	AVAIL-ABLE	USED	AVAIL-ABLE		
1	11/24 CPU	11/24	6.0	26	.6	2.4	.1	1.9	1	19
	PHYSICAL ADDRESS EXTENSION	KT24	4.5	21.5	.001	2.4	.001	1.9	1	18
	1 MB-ECC	MS11-PB	4.8	16.7	0	2.4	0	1.9	1	17
2										
	UNIBUS TERMINATOR	QUAD SLOT								

CARRY TO NEXT BOX ►

**NOTE:**

Maximum memory capacity is 1 MS11-PB module or 3 MS11-LD modules. The second slot in the 11/24 backplane is reserved for the 11/24 physical address extension option (KT24).

\*Each MS11-LD or MS11-PB consumes one bus load in the PDP-11/24. Each MS11-LD or MS11-PB consumes no bus loads in the PDP-11/44.

# PDP-11/24 Rack-mountable Computers

---

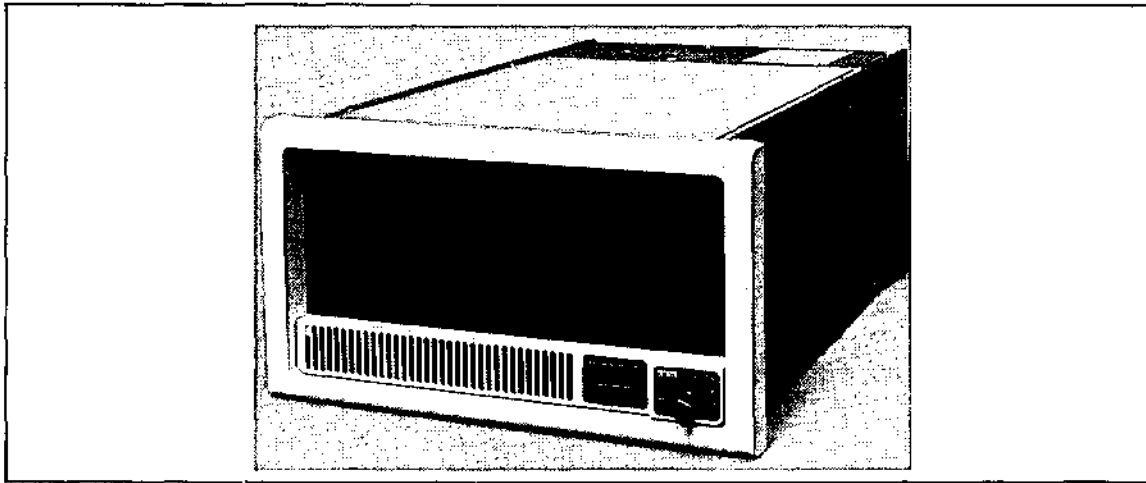

## PDP-11/24 10.5 inch Rack-mountable Computer

The PDP-11/24 is available in a 26.6 cm (10.5 in) rack-mountable variation that provides significantly more expansion space. This box configuration offers memory expansion to a maximum of 4 MB using MS1 1-PB memory modules. Power and space for the addition of 4 System Units are provided.

### 11/24-DC(DD)

The 11/24-DC(DD) includes the following:

- PDP-11/24 CPU and power supply
- KT24 Physical Address Extension (PAX) module
- 1 MB ECC MOS memory (MS1 1-PB)
- Four System Units of additional expansion space
- Rack-mountable 26.6 cm (10.5 in) box

### Site Preparation Specifications:

- Height: 26.3 cm (10.4 in)
- Width: 42.2 cm (16.6 in)
- Depth: 69 cm (26 in)
- Weight: 40.9 kg (90 lb)
- Watts: 262 as configured  
1350 in maximum configuration
- Btu/hr: 890/4600
- Receptacles:  
NEMA #5-20R (120VAC/60Hz), #6-20R (240VAC/  
50Hz)

# PDP-11/24 Rack-mountable Computers

**11/24-DC(DD) SYSTEM CONFIGURATOR**

CPU BOX		OPTION	DC POWER						BUS LOADS	
			@+5V		@+15V		@-15V		USED	AVAIL-ABLE
			USED	AVAIL-ABLE	USED	AVAIL-ABLE	USED	AVAIL-ABLE		
				103.5		3.0		3.0		20
1	11/24 CPU	11/24	6.0	97.5	.6	2.4	.1	2.9	1	19
	PHYSICAL ADDRESS EXTENSION	KT24	4.5	93	.001	2.4	.001	2.9	1	18
	1 MB ECC MOS MEMORY	MS11-PB	4.8	88.2	0	2.4	0		1	17
2										
3	UNIBUS TERMINATOR									
	QUAD SLOT									
4	SU									
5	SU									
6	SU									

CARRY TO NEXT BOX ►

**NOTE:**

System units 3 to 6 can be used for module expansion by adding DD11-CK or DD11-DK backplanes. The DD11-CK occupies one SU and allows 2 quad and 2 hex slots for expansion. The DD11-DK occupies two SU and gives 2 quad and 7 hex slots for expansion.

Maximum memory capacity is 4 MS11-PB modules.

\*Each MS11-LD or MS11-PB consumes one bus load in the PDP-11/24. Each MS11-LD or MS11-PB consumes no bus loads in the PDP-11/44.



# PDP-11/44 Rack-mountable Computer

---

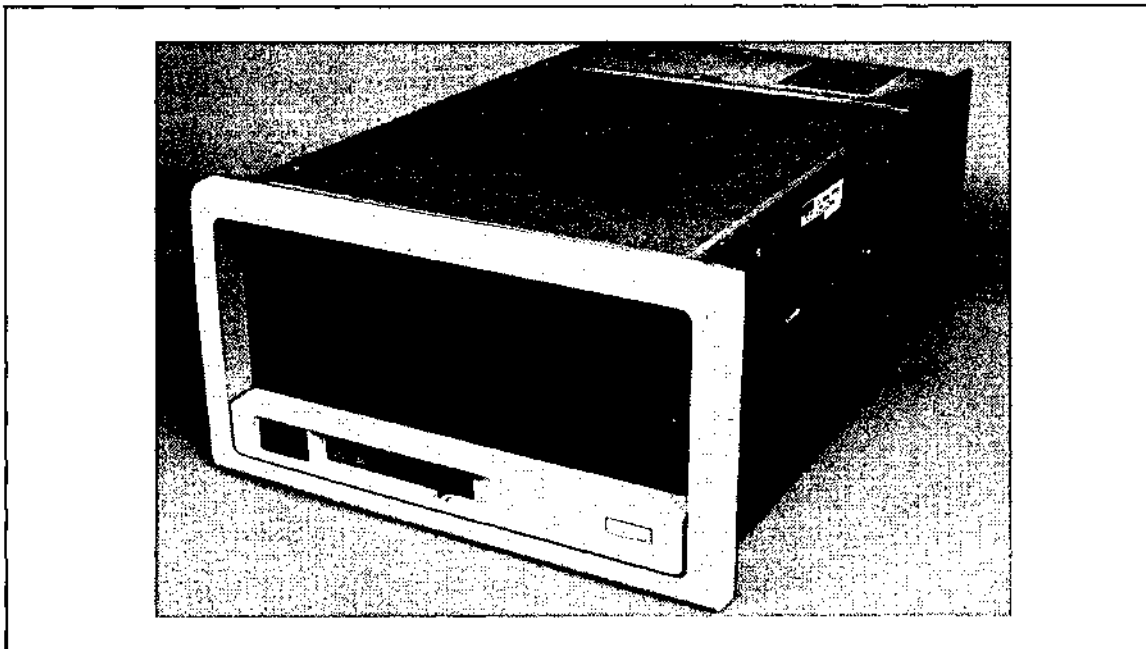

The PDP-11/44 is available in a 26.6 cm (10.5 in) rack-mountable version. It offers memory expansion up to 4 MB in the four pre-wired slots in the CPU backplane. The PDP-11/44 computer provides ample power and expansion space for configuration flexibility.

## **11/44-DA(DB)**

The PDP-11/44-DA(DB) includes the following:

- PDP-11/44 CPU and power supply
- 1 MB ECC MOS Memory (MS11-PB)
- Three system units of additional expansion space plus one hex and one quad slot
- Rack-mountable 26.6 cm (10.5 in) box

## **Site Preparation Specifications:**

- Height: 26.3 cm (10.4 in)
- Width: 42.2 cm (16.6 in)
- Depth: 69 cm (26 in)
- Weight: 42.2 kg (93 lb)
- Watts: 379 as configured  
1350 in maximum configuration
- Btu/hr: 1290/4100
- Receptacles:  
NEMA #5-20R (120VAC/60Hz), #6-15R (240VAC/  
50Hz)

# PDP-11/44 Rack-mountable Computer

## 11/44-DA(DB) SYSTEM CONFIGURATOR

CPU BOX		DC POWER						BUS LOADS	
		@+5V		@+15V		@-15V		USED	AVAIL-ABLE
		USED	AVAIL-ABLE	USED	AVAIL-ABLE	USED	AVAIL-ABLE		
			103.5		3.0		3.0		20
1	CIM								
	RESERVED FOR CIS (KE44-A)								
	RESERVED FOR FLOATING POINT PROCESSOR (FP11-F)								
2	11/44 CPU	34		0		0		1	19
	1 MB MOS MEMORY	MS11-PB	4.8		0		0	0	19
	RESERVED FOR MEMORY								
	RESERVED FOR MEMORY								
3	RESERVED FOR MEMORY								
	HEX SLOT								
	UNIBUS TERMINATOR								
	QUAD SLOT								
4	SU								
5	SU								
6	SU								

CARRY TO NEXT BOX ►

**Note:** System units 4 to 6 can be used for module expansion by adding DD11-CK or DD11-DK backplanes. The DD11-CK occupies (1) SU and allows (2) quad and (2) hex slots for expansion. The DD11-DK occupies (2) SU and gives (2) quad and (7) hex slots for expansion.

\*Each MS11-LD or MS11-PB consumes one bus load in the PDP-11/24. Each MS11-LD or MS11-PB consumes no bus loads in the PDP-11/44.

# PDP-11/24 Kernel Computer

---

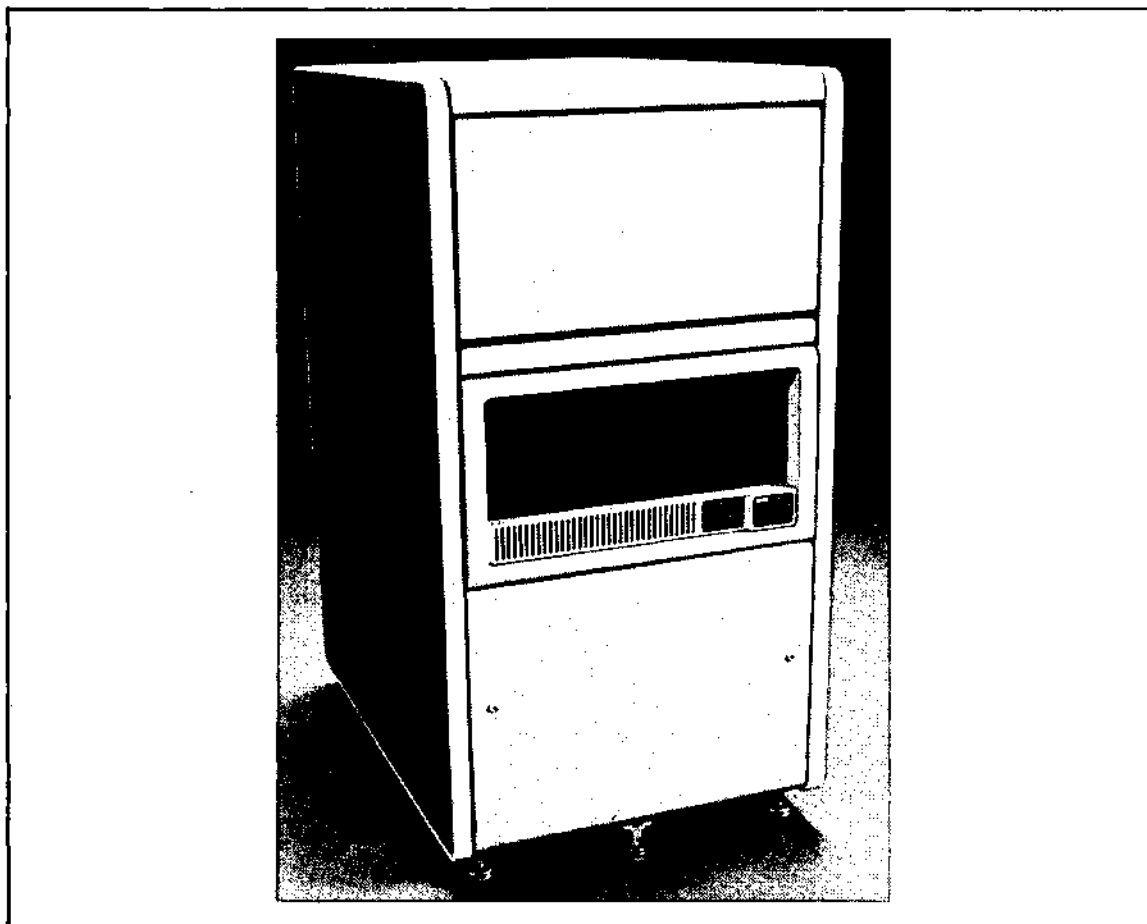

The PDP-11/24 is available in a cabinet-mounted model. It provides a foundation for building tailored system configurations and includes the 11/24-DC(DD) box product housed in an H9642 CPU cabinet.

This configuration includes:

- PDP-11/24 CPU and power supply
- KT24 Physical Address Extension (PAX) module
- 1 MB ECC MOS memory (MS11-PB)
- Four System Units of additional expansion space
- I/O Connection Panel
- H9642 CPU cabinet with power controller
- 26.6 cm (10.5 in) mounting space at the top of the cabinet that will accommodate one of the following: RA80, RA81, RL02, RX02, TU58

## Site Preparation Specifications:

### CPU Cabinet

- Height: 106 cm (41.7 in)
- Width: 54.1 cm (21.3 in)
- Depth: 80 cm (31.5 in)
- Weight: 135 kg (298 lb)
- Watts: 262 as configured  
1350 in maximum configuration
- Btu/hr: 890/4600
- Receptacles:  
NEMA #L5-30R (120VAC/60Hz),  
#6-15R (240VAC/50Hz)

## Ordering Information:

**11X24-FA(FB)** PDP-11/24 Kernel in standard H9642 cabinet

# PDP-11/24 Kernel Computer

## 11X24-FA(FB) SYSTEM CONFIGURATOR

CPU BOX		OPTION	DC POWER						BUS LOADS		PANEL UNITS	
			@+5V		@+15V		@-15V		USED	AVAIL-ABLE	USED	AVAIL-ABLE
			USED	AVAIL-ABLE	USED	AVAIL-ABLE	USED	AVAIL-ABLE				
				103.5		3.0		3.0		20		12
1	11/24 CPU	11/24	6.0	97.5	.6	2.4	.1	2.9	1	19		
	PHYSICAL ADDRESS EXTENSION	KT24	4.5	93	.001	2.4	.001	2.9	1	18		
	1 MB MOS MEMORY	MS11-PB	4.8	88.2	0	2.4	0	2.9	1	17		
2												
3	UNIBUS TERMINATOR											
	QUAD SLOT											
4	SU											
5	SU											
6	SU											

CARRY TO NEXT BOX ►

**Note:** Maximum memory capacity is 4 MB using MS11-PB modules. The second slot in the 11/24 backplane is reserved for the physical address extension option (KT24).

\*Each MS11-LD or MS11-PB consumes one bus load in the PDP-11/24. Each MS11-LD or MS11-PB consumes no bus loads in the PDP-11/44.

# PDP-11/44 Kernel Computers

---

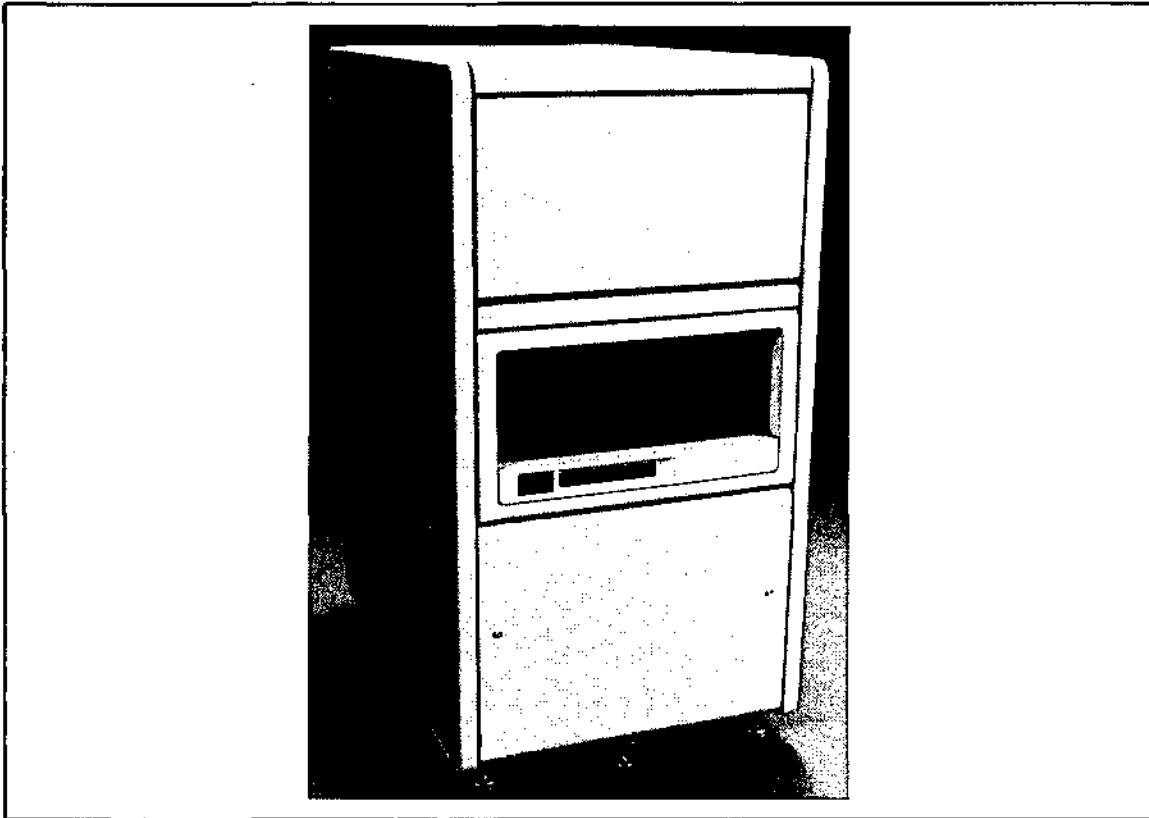

The PDP-11/44 is available in a cabinet-mounted variation. This configuration is built around the 11/44-DA(DB) box product and housed in an H9642 CPU cabinet. The kernel is intended to provide a foundation for building system configurations tailored for unique applications.

This configuration includes: .

- PDP-11/44 CPU and power supply
- 1 MB ECC MOS memory (MS11-PB)
- Three system units of additional expansion space
- I/O Connection Panel
- H9642 cabinet with power controller
- 26.6 cm (10.5 in) mounting space at the top of the cabinet which will accommodate one of the following: RA80, RA81, RLO2, RX02, TU58

## Site Preparation Specifications:

### Cabinet

- Height: 106 cm (41.7 in)
- Width: 54.1 cm (21.3 in)
- Depth: 80 cm (31.5 in)
- Weight: 137 kg (302 lb)
- Watts: 379 as configured  
1350 in maximum configuration
- Btu/hr: 1290/4600
- Receptacles:  
NEMA #L5-30R (120VAC/60Hz),  
#6-15R (240VAC/50Hz)

## Ordering Information:

11X44-FA(FB) PDP-11/44 Kernel in H9642 cabinet

# PDP-11/44 Kernel Computers

11X44-FA(FB) SYSTEM CONFIGURATOR

CPU BOX		OPTION	DC POWER				BUS LOADS		PANEL UNITS	
			@+5V		@+15V		@-15V		USED	AVAIL-ABLE
			USED	AVAIL-ABLE	USED	AVAIL-ABLE	USED	AVAIL-ABLE		
			103.5		3.0		3.0	20	12	
1	CIM									
	RESERVED FOR CIS (KE44-A)									
2	RESERVED FOR FLOATING POINT PROCESSOR (FP11-F)									
	11/44 CPU	11/44 CPU	34	0	0	1	19			
3	1 MB MOS MEMORY	MS11-PB	4.8	0	0	0	19			
	RESERVED FOR MEMORY									
	RESERVED FOR MEMORY									
	RESERVED FOR MEMORY									
	HEX SLOT									
4	UNIBUS TERMINATOR									
	QUAD SLOT									
5	SU									
6	SU									

CARRY TO NEXT BOX ►

**Note:** System units 4 to 6 can be used for module expansion by adding DD11-CK or DD11-DK backplanes. The DD11-CK occupies (1) SU and allows (2) quad and (2) hex slots for expansion. The DD11-DK occupies (2) SU and gives (2) quad and (7) hex slots for expansion.

\*Each MS11-LD or MS11-PB consumes one bus load in the PDP-11/24. Each MS11-LD or MS11-PB consumes no bus loads in the PDP-11/44.

# PDP-11/24 Building Blocks

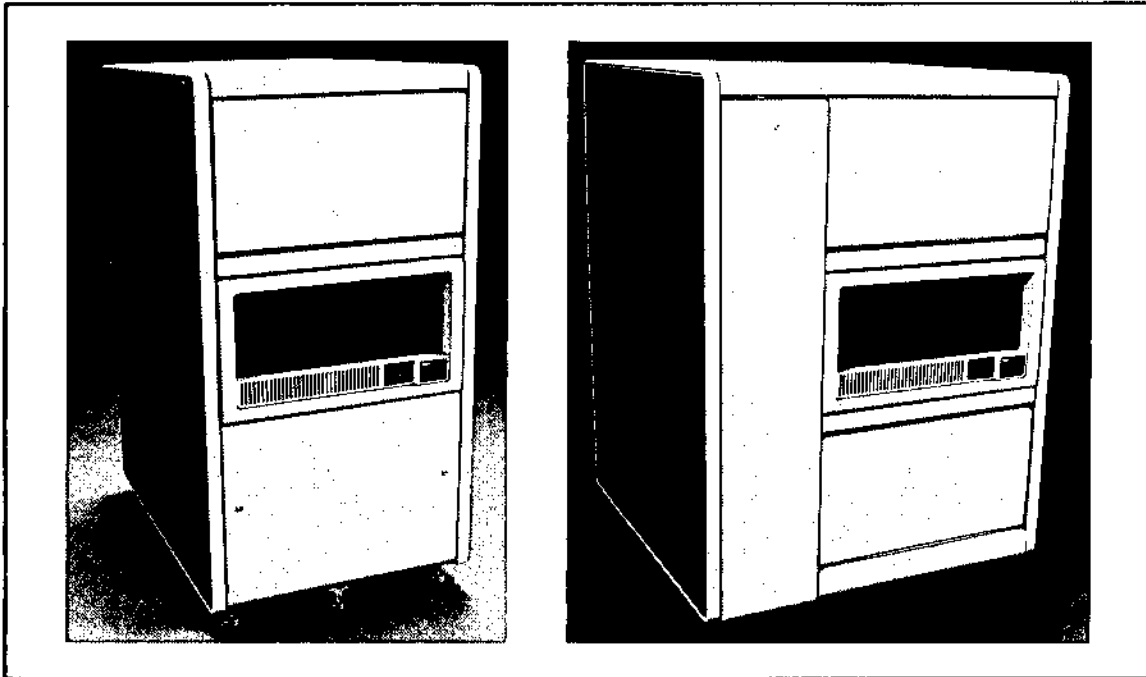

The PDP-11/24 is offered in two building block variations that consist of a 26.6 cm (10.5 in) box computer, a cabinet with power controller, and the PDP-11 Operating System General License. The standard width cabinet (H9642) variation provides expansion mounting space for one 26.6 cm (10.5 in) or 13.3 cm (5.25 in) disk or tape option. The wide cabinet (H9645) provides expansion mounting space for two 26.6 cm (10.5 in) or 13.3 cm (5.25 in) devices. The expansion mounting space may be used for Digital mass storage devices or customer equipment. Select from the list of storage products included under ordering information. **Note:** The RA60 requires a deeper cabinet (H9642-AP(AR)) and therefore, cannot be mounted in either of these cabinets.

The PDP-11/24 Building Blocks include the following:

- CPU and power supply
- 1 MB ECC MOS memory (MS11-PB)
- I/O Connection Panel
- PDP-11 Operating System General License
- BC22D EIA cable for console terminal
- H9642 or H9645 CPU cabinet with power controller
- KT24 Physical Address Extension module

## Ordering Information:

**SX-FX100-EK(EN)** PDP-11/24 Standard cabinet building block

**Cabinet accommodates one:** TU58-DA  
RUA80-AA  
RUA81-AA  
RL211-AK  
RX211-BK

**SX-FX200-EK(EN)** PDP-11/24 wide cabinet building block

**Cabinet accommodates two:** Same list as above. Due to AC power limitations, a maximum of one RA80/RA81 is allowed per cabinet.

## Site Preparation Specifications:

### H9642 Cabinet

- Height: 106 cm (41.7 in)
- Width: 54.1 cm (21.3 in)
- Depth: 80 cm (31.5 in)
- Weight: 137 kg (302 lb)
- Watts: 262 as configured  
1350 in maximum configuration
- Btu/hr: 890/4600
- Receptacles:  
NEMA #L5-30R (120VAC/60Hz),  
#6-15R (240VAC/50Hz)

## Site Preparation Specifications:

### H9645 CPU Cabinet

- Height: 106 cm (41.7 in)
- Width: 73.6 cm (29 in)
- Depth: 80 cm (31.5 in)
- Weight: 162 kg (358 lb)
- Watts: 262 as configured  
1350 in maximum configuration
- Btu/hr: 890/4600
- Receptacles:  
NEMA #L5-30R (120VAC/60Hz),  
#6-15R (240VAC/50Hz)

# PDP-11/24 Building Blocks

## SX-FX100-EK(EN) AND SX-FX200-EK(EN) SYSTEM CONFIGURATOR

CPU BOX		OPTION	DC POWER						BUS LOADS		PANEL UNITS	
			@+5V		@+15V		@-15V		USED	AVAIL-ABLE	USED	AVAIL-ABLE
			USED	AVAIL-ABLE	USED	AVAIL-ABLE	USED	AVAIL-ABLE				
				103.5		3.0		3.0		20		12
1	11/24 CPU	11/24	6.0	97.5	.6	2.4	.1	2.9	1	19		
	PHYSICAL ADDRESS EXTENSION*	KT24	4.5	93	.001	2.4	.001	2.9	1	18		
	1 MB MOS MEMORY	MS11-PB	4.8	88.2	0	2.4	0	2.9	1	17		
2												
3	UNIBUS TERMINATOR											
	QUAD SLOT											
4	SU											
5	SU											
6	SU											
CARRY TO NEXT BOX ►												

**Note:** Maximum memory capacity is 4 MB using MS11-PB modules. The second slot in the 11/24 backplane is reserved for the physical address extension option (KT24).

\*Each MS11-LD or MS11-PB consumes one bus load in the PDP-11/24. Each MS11-LD or MS11-PB consumes no bus loads in the PDP-11/44.



# PDP-11/44 Building Blocks



The PDP-11/44 is offered in two building block variations that consist of a 26.6 cm (10.5 in) box computer, a cabinet with power controller, and the PDP-11 Operating System General License. The standard width cabinet (H9642) variation provides expansion mounting space for one 26.6 cm (10.5 in) or 13.3 cm (5.25 in) disk or tape option. The wide cabinet (H9645) provides expansion mounting space for two 26.6 cm (10.5 in) or 13.3 cm (5.25 in) devices. The expansion mounting space may be used for Digital mass storage devices or customer equipment. Select from the list of storage products included under ordering information. **Note:** The RA60 requires a deeper cabinet (H9642-AP(AR)) and therefore, cannot be mounted in either of these cabinets.

The PDP-11/44 Building Blocks include the following:

- CPU and power supply
- 1 MB ECC MOS memory (MS11-PB)
- I/O Connection Panel
- PDP-11 Operating System General License
- BC22D EIA cable for console terminal
- H9642 or H9645 CPU cabinet with power controller

## Ordering Information:

**SX-40100-EK(EN)** PDP-11/44 Standard cabinet building block

**Cabinet accommodates one:** TU58-DA  
RUA80-AA  
RUA81-AA  
RL211-AK  
RX211-BK

**SX-40200-EK(EN)** PDP-11/44 wide cabinet building block

**Cabinet accommodates two:** Same list as above. Due to AC power limitations, a maximum of one RA80/RA81 is allowed per cabinet.

## Site Preparation Specifications:

### H9642 Cabinet

- Height: 106 cm (41.7 in)
- Width: 54.1 cm (21.3 in)
- Depth: 80 cm (31.5 in)
- Weight: 137 kg (302 lb)
- Watts: 379 as configured  
1350 in maximum configuration
- Btu/hr: 1290/4100
- Receptacles:  
NEMA #L5-30R (120VAC/60Hz),  
#6-15R (240VAC/50Hz)

## Site Preparation Specifications:

### H9645 CPU Cabinet

- Height: 106 cm (41.7 in)
- Width: 73.6 cm (29 in)
- Depth: 80 cm (31.5 in)
- Weight: 162 kg (358 lb)
- Watts: 379 as configured  
1350 in maximum configuration
- Btu/hr: 1290/4100
- Receptacles:  
NEMA #L5-30R (120VAC/60Hz),  
#6-15R (240VAC/50Hz)

# PDP-11/44 Building Blocks

## SX-40100-EK(EN) AND SX-40200-EK(EN) SYSTEM CONFIGURATOR

CPU BOX		OPTION	DC POWER				BUS LOADS		PANEL UNITS	
			@+5V		@+15V		@-15V		USED	AVAIL-ABLE
			USED	AVAIL-ABLE	USED	AVAIL-ABLE	USED	AVAIL-ABLE		
			103.5		3.0		3.0	20	12	
1	CIM									
	RESERVED FOR CIS (KE44-A)									
	RESERVED FOR FLOATING POINT PROCESSOR (FP11-F)									
	11/44 CPU	11/44 CPU	34	0	0	1	19			
	1 MB MOS MEMORY	MS11-PB	4.8	0	0	0	19			
	RESERVED FOR MEMORY									
2	RESERVED FOR MEMORY									
	RESERVED FOR MEMORY									
	RESERVED FOR MEMORY									
3	HEX SLOT									
	UNIBUS TERMINATOR    QUAD SLOT									
4	SU									
	SU									
	SU									
5	SU									
	SU									
6	SU									
	SU									
CARRY TO NEXT BOX ►										

**Note:** System units can be used for module expansion by adding DD11-CK or DD11-DK backplanes. The DD11-CK occupies (1) SU and allows (2) quad and (2) hex slots for expansion. The DD11-DK occupies (2) SU and gives (2) quad and (7) hex slots for expansion.

\*Each MS11-LD or MS11-PB consumes one bus load in the PDP-11/24. Each MS11-LD or MS11-PB consumes no bus loads in the PDP-11/44.

# PDP-11/24 Dual RLO2 Packaged System

---

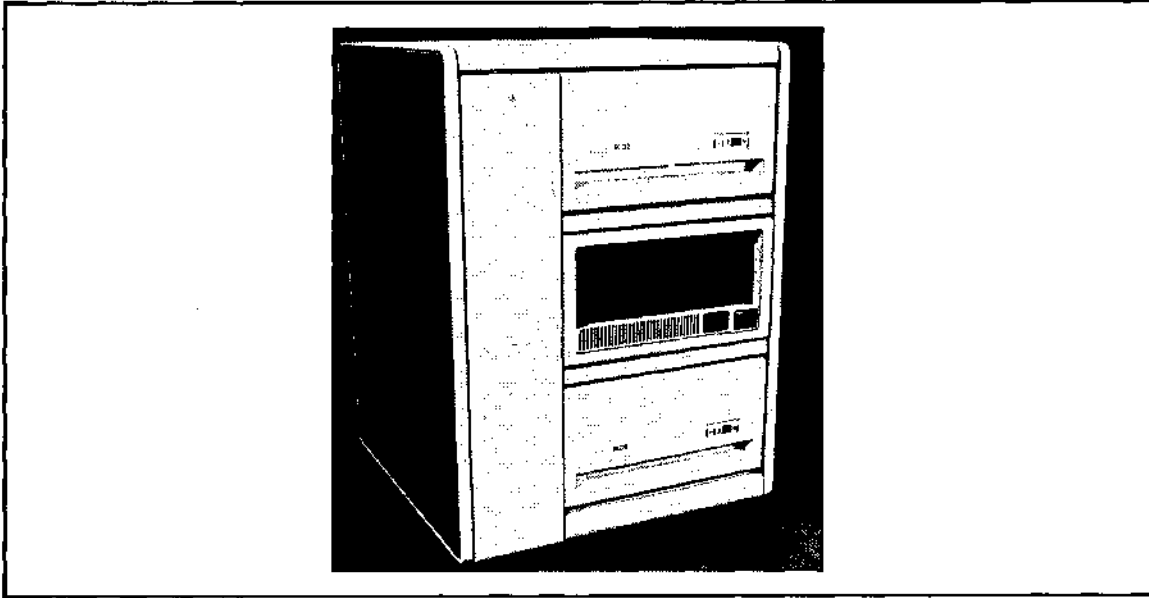

The PDP-11/24 Dual RLO2 system configuration provides all the standard features of the PDP-11/24 DC(DD) box product plus 20.8 MB of disk storage capacity.

The PDP-11/24 Dual RLO2 System includes:

- PDP-11/24 CPU and power supply
- KT24 Physical Address Extension (PAX) module
- 1 MB ECC MOS memory (MS11-PB)
- Four System Units of additional expansion space
- H9645 wide CPU cabinet with power controller
- Two RLO2 10.4 MB removable-cartridge disk drives and controller
- One BC22D-25 EIA cable for a console terminal (console terminal not included)
- I/O Connection Panel
- PDP-11 Operating System General License

## CPU Cabinet Expansion

The CPU cabinet provides side mounting space for an optional H7750 battery backup unit and the I/O Connection Panel provides mounting space for option panel inserts.

## Memory Expansion

Three additional MS11-PB memory modules may be added for memory expansion in 1 MB increments (maximum memory capacity is 4 MB).

## Mass Storage Expansion

The RLO2 disk controller can accommodate up to four RLO2 disk drives. Two additional drives may be added to this system configuration. An H9642 disk cabinet is required.

## Site Preparation Specifications:

### H9645 CPU Cabinet

- Height: 106 cm (41.7 in)
- Width: 73.6 cm (29 in)
- Depth: 80 cm (31.5 in)
- Weight: 230 kg (506 lb)
- Watts: 544 as configured  
1500 in maximum configuration
- Btu/hr: 1850/5100
- Receptacles:  
NEMA #L5-30R (120VAC/60Hz),  
#6-15R (240VAC/50Hz)

## Ordering Information:

SX-FXMMB-  
EK(EN)

PDP-11/24 Dual RLO2 Packaged System

# PDP-11/24 Dual RLO2 Packaged System

**SX-FXMMB-EK(EN) SYSTEM CONFIGURATOR**

CPU BOX		OPTION	DC POWER						BUS LOADS		PANEL UNITS	
			@+5V		@+15V		@-15V		USED	AVAIL-ABLE	USED	AVAIL-ABLE
			USED	AVAIL-ABLE	USED	AVAIL-ABLE	USED	AVAIL-ABLE				
				103.5		3.0		3.0		20		12
1	11/24 CPU	11/24	6.0	97.5	0.6	2.4	0.1	2.9	1	19		
	PHYSICAL ADDRESS EXTENSION	KT24	4.5	93	.001	2.4	.001	2.9	1	18		
	1 MB MOS MEMORY	MS11-PB	4.8	88.2	0	2.4	0	2.9	1	17		
	HEX SLOT											
	HEX SLOT											
	HEX SLOT											
	HEX SLOT											
2	CONTROLLER FOR RL02	RL211	5.0		0.5		0.5		1		1	
	UNIBUS TERMINATOR QUAD SLOT											
3	SU											
4	SU											
5	SU											
6	SU											
CARRY TO NEXT BOX ►												

**Note:** System units 3 to 6 can be used for module expansion by adding DD11-CK or DD11-DK backplanes. The DD11-CK occupies (1) SU and allows (2) quad and (2) hex slots for expansion. The DD11-DK occupies (2) SU and gives (2) quad and (7) hex slots for expansion.

\*Each MS11-LD or MS11-PB consumes one bus load in the PDP-11/24. Each MS11-LD or MS11-PB consumes no bus loads in the PDP-11/44.

# PDP-11/24 RA80/RL02 Packaged System

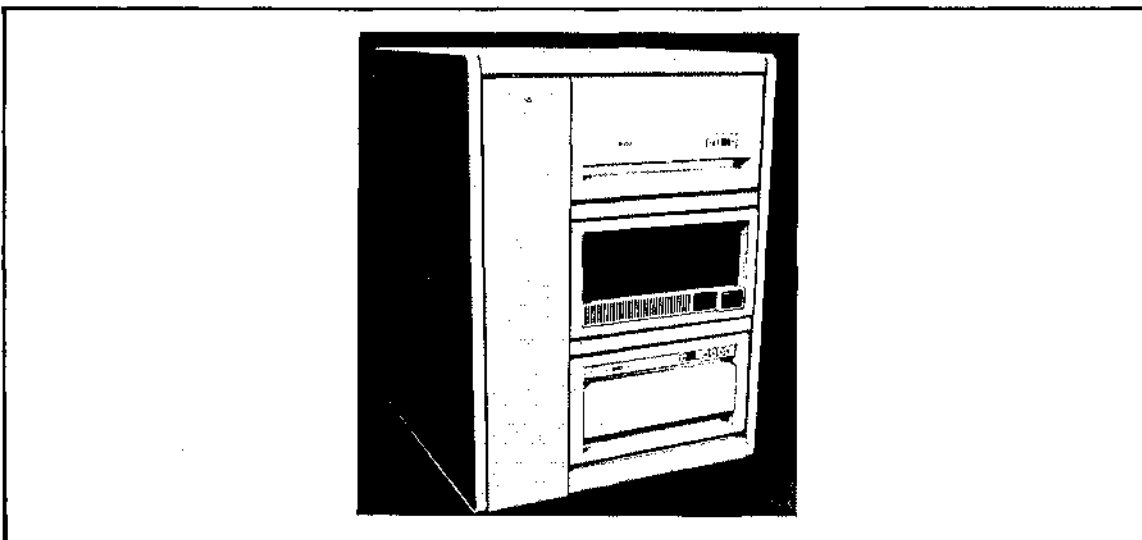

The PDP-11/24 RA80/RL02 configuration provides all the standard features of the PDP-11/24-DC(DD) box product and 121 MB fixed and 10 MB removable disk storage.

The PDP-11/24 RA80/RL02 System includes:

- PDP-11/24 CPU and power supply
- KT24 Physical Address Extension (PAX) module
- 1 MB ECC MOS memory (MS1 1-PB)
- Four System Units of additional expansion space
- One 121 MB RA80 disk drive and UDA50 controller
- One 10.4 MB RL02 removable-cartridge disk drive and controller
- H9645 wide CPU cabinet with power controller
- One BC22D-25 EIA cable for a console terminal (console terminal not included)
- I/O Connection Panel
- PDP-11 Operating System General License

## **CPU Cabinet Expansion**

The CPU cabinet provides side mounting space for an optional H7750 battery backup unit and the I/O Connection Panel provides mounting space for option panel inserts.

## **Memory Expansion**

Additional MS1 1-PB memory modules may be added for memory expansion in 1 MB increments (maximum memory capacity is 4 MB).

## **Mass Storage Expansion**

The RA80 and RL02 controllers in this system can accommodate up to four drives each. Three RA80, RA81, or RA60 drives and three RL02 disk drives may be added. Additional H9642 disk cabinets are required.

## **Site Preparation Specifications:**

### **CPU Cabinet**

- Height: 106 cm (41.7 in)
- Width: 73.6 cm (29 in)
- Depth: 76.2 cm (30 in)
- Weight: 264 kg (582 lb)
- Watts: 1240 as configured  
2250 in maximum configuration
- BTU/hr: 4100/7650
- Receptacles:  
NEMA #L5-30R (120VAC/60Hz),  
#6-15R (240VAC/50Hz)

## **Ordering Information:**

**SX-FXGMB-  
EK(EN)**      PDP-11/24 RA80/RL02 Packaged  
System

# PDP-11/24 RA80/RLO2 Packaged System

## SX-FXGMB-EK(EN) SYSTEM CONFIGURATOR

CPU BOX		OPTION	DC POWER						BUS LOADS		PANEL UNITS	
			@+5V		@+15V		@-15V		USED	AVAIL-ABLE	USED	AVAIL-ABLE
			USED	AVAIL-ABLE	USED	AVAIL-ABLE	USED	AVAIL-ABLE				
				103.5		3.0		3.0		20		12
1	11/24 CPU	11/24	6.0	97.5	0.6	2.4	0.1	2.9	1	19		
	PHYSICAL ADDRESS EXTENSION	KT24	4.5	93	.001	2.4	.001	2.9	1	18		
	1 MB MOS MEMORY	MS11-PB	4.8	88.2	0	2.4	0	2.9	1	17		
	CONTROLLER FOR RL02	RL211	5.0	83.2	0.5	1.9	0.5	2.4	1	16	1	
	HEX SLOT											
	HEX SLOT											
2	CONTROLLER FOR RA80	UDA50	12.75		.04		1.3		1		1	
	UNIBUS TERMINATOR	QUAD SLOT										
3	SU											
4	SU											
5	SU											
6	SU											
CARRY TO NEXT BOX ►												

**Note:** System units 3 to 6 can be used for module expansion by adding DD11-CK or DD11-DK backplanes. The DD11-CK occupies (1) SU and allows (2) quad and (2) hex slots for expansion. The DD11-DK occupies (2) SU and gives (2) quad and (7) hex slots for expansion.

\*Each MS11-LD or MS11-PB consumes one bus load in the PDP-11/24. Each MS11-LD or MS11-PB consumes no bus loads in the PDP-11/44.

# PDP-11/44 Dual RLO2 Packaged System

---

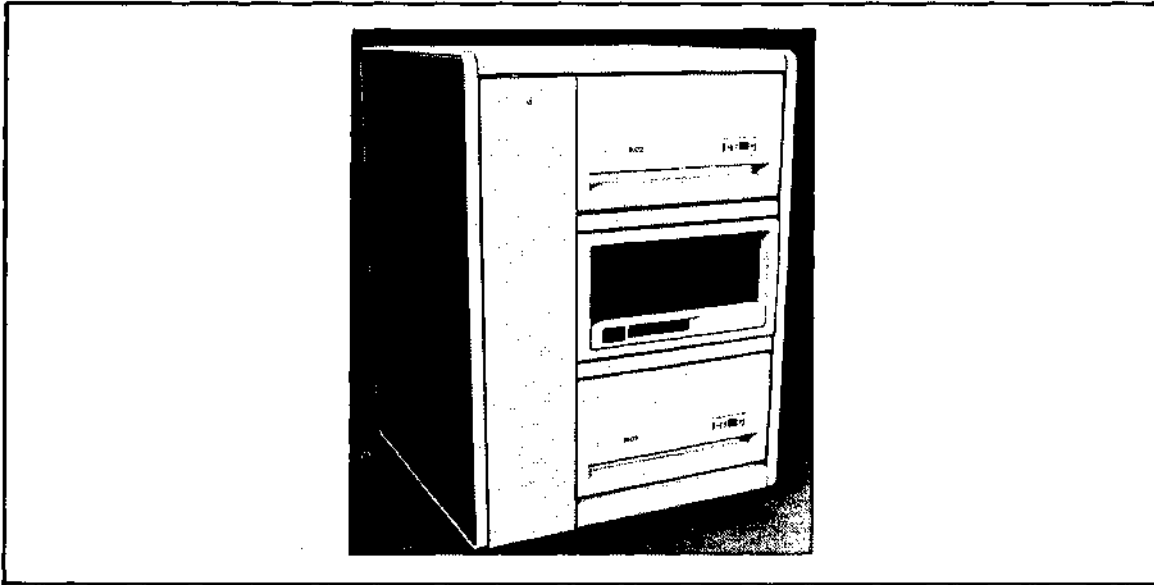

The PDP-11/44 Dual RLO2 system configuration provides all the standard features of the PDP-11/44-DA(DB) and 20.8 MB of removable mass storage capacity.

The PDP-11/44 Dual RLO2 System includes:

- PDP-11/44 CPU and power supply
- 1 MB ECC MOS memory (MS1 1-PB)
- H9645 wide CPU cabinet with power controller
- Two RLO2 10.4 MB removable cartridge disk drives and controller
- One BC22D-25 EIA cable for console terminal (console terminal not included)
- I/O Connection Panel
- PDP-11 Operating System General License

## **CPU Cabinet Expansion**

The CPU cabinet provides expansion space for the optional H7750 battery backup unit, and the I/O Connection Panel provides mounting space for option panel inserts.

## **Memory Expansion**

The PDP-11/44 CPU backplane provides four dedicated slots for memory expansion. In this configuration there are three slots available for memory expansion in 1 MB increments (maximum memory capacity is 4 MB).

## **Mass Storage Expansion**

The RL211 disk controller supports up to 4 RLO2 drives. Two more RLO2 drives may be added to this system. An additional H9642 cabinet is required.

## **Site Preparation Specifications:**

### **CPU Cabinet**

- Height: 106 cm (41.7 in)
- Width: 73.6 cm (29 in)
- Depth: 80 cm (31.5 in)
- Weight: 232 kg (510 lb)
- Watts: 640 as configured  
1500 in maximum configuration
- Btu/hr: 2175/5100
- Receptacles:  
NEMA #L5-30R (120VAC/60Hz),  
#6-15R (240VAC/50Hz)

## **Ordering Information:**

SX-40MMB- PDP-11/44 RLO2 Packaged System  
EK(EN)

# PDP-11/44 Dual RLO2 Packaged System

**SX-40MMB-EK(EN) SYSTEM CONFIGURATOR**

CPU BOX		OPTION	DC POWER						BUS LOADS		PANEL UNITS	
			@+5V		@+15V		@-15V		USED	AVAIL-ABLE	USED	AVAIL-ABLE
			USED	AVAIL-ABLE	USED	AVAIL-ABLE	USED	AVAIL-ABLE				
				103.5		3.0		3.0		20		12
1	CIM											
	RESERVED FOR CIS											
	RESERVED FLOATING POINT PROCESSOR											
	11/44 CPU	11/44 CPU	34	0	0	0	0	1	19			
	1 MB MOS MEMORY	MS11-PB	4.8	0	0	0	0	0	19			
	RESERVED FOR ECC MOS MEMORY											
2	RESERVED FOR ECC MOS MEMORY											
	RESERVED FOR ECC MOS MEMORY											
	RESERVED FOR ECC MOS MEMORY											
	CONTROLLER FOR RL02 DISK DRIVES	RL211	5.0	.5	.5	.5	.5	1	1			
3	UNIBUS TERMINATOR											
	QUAD SLOT											
	SU											
4	SU											
	SU											
5	SU											
	SU											
6	SU											
	SU											
CARRY TO NEXT BOX ►												

**Note:** System units 4 to 6 can be used for module expansion by adding DD11-CK or DD11-DK backplanes. The DD11-CK occupies (1) SU and allows (2) quad and (2) hex slots for expansion. The DD11-DK occupies (2) SU and gives (2) quad and (2) hex slots for expansion.

\*Each MS11-LD or MS11-PB consumes one bus load in the PDP-11/24. Each MS11-LD or MS11-PB consumes no bus loads in the PDP-11/44.



# PDP-11/44 RA80/RL02 Packaged System

---

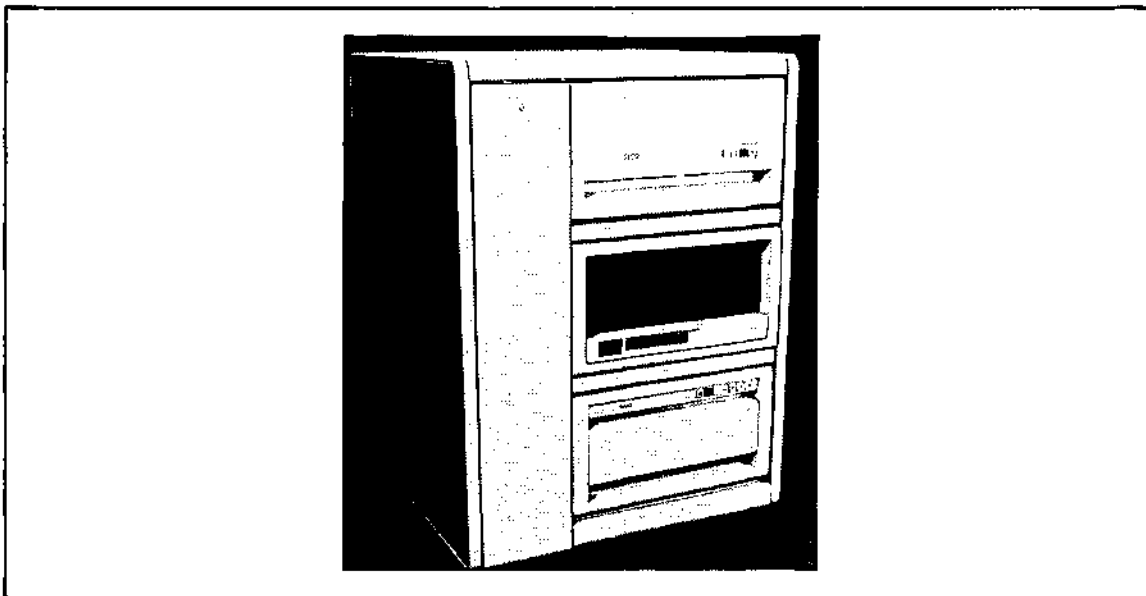

The PDP-11/44 RA80/RL02 system provides all the standard features of the PDP-11/44-DA(DB) box product plus an expansion backplane and 121 MB fixed and 10.4 MB removable disk storage.

The PDP-11/44 RA80/RL02 System includes:

- PDP-11/44 CPU and power supply
- 1 MB ECC MOS memory
- DD11-DK 9-slot expansion backplane
- One 121 MB RA80 disk drive and UDA50 controller
- One RL02 10.4 MB removable cartridge disk drive and controller
- One BC22D-25 EIA cable for console terminal (console terminal not included)
- H9645 wide CPU cabinet with power controller
- I/O Connection Panel
- PDP-11 Operating System General License

## CPU Cabinet Expansion

The CPU cabinet provides expansion space for an optional H7750 battery backup unit and the I/O Connection Panel provides mounting space for option panel inserts.

## Memory Expansion

The CPU backplane provides three slots for memory expansion using MS11-PB modules (maximum memory capacity is 4 MB).

## Mass Storage

The RL02 and UDA50 disk controllers in this system can accommodate up to four drives each. Three RA80, RA81 or RA60 disk drives and three RL02 disk drives may be added. Additional H9642 disk cabinets are required.

## Site Preparation Specifications:

### CPU Cabinet

- Height: 106 cm (41.7 in)
- Width: 73.6 cm (29 in)
- Depth: 80 cm (31.5 in)
- Weight: 266 kg (586 lb)
- Watts: 1360 as configured  
2250 in maximum configuration
- Btu/hr: 4625/7650
- Receptacles:  
NEMA #L5-30R (120VAC/60Hz),  
#6-15R (240VAC/50Hz)

## Ordering Information:

**SX-40GMB-** PDP-11/44 RA80/RL02 System  
**EK(EN)**

# PDP-11/44 RA80/RLO2 Packaged System

## SX-40GMB-EK(EN) SYSTEM CONFIGURATOR

CPU BOX		OPTION	DC POWER						BUS LOADS		PANEL UNITS	
			@+5V		@+15V		@-15V		USED	AVAIL-ABLE	USED	AVAIL-ABLE
			USED	AVAIL-ABLE	USED	AVAIL-ABLE	USED	AVAIL-ABLE				
				103.5		3.0		3.0		20		12
1	CIM											
	RESERVED FOR CIS											
2	RESERVED FOR FLOATING POINT PROCESSOR											
	11/44 CPU	11/44 CPU	34		0		0		1	19		
	1 MB MOS MEMORY	MS11-PB	4.8		0		0		0	19		
	RESERVED FOR ECC MOS MEMORY											
3	RESERVED FOR ECC MOS MEMORY											
	RESERVED FOR ECC MOS MEMORY											
	CONTROLLER FOR RL02	RL211	5.0		.5		.5		1		1	
4	UNIBUS QUAD SLOT											
	UNIBUS QUAD SLOT											
	HEX SLOT											
	HEX SLOT											
	HEX SLOT											
	HEX SLOT											
5	CONTROLLER FOR RA80 DISK DRIVE	UDA 50	12.75		.04		1.3		1		1	
	UNIBUS TERMINATOR QUAD SLOT											
6	SU											

CARRY TO NEXT BOX ►

**Note:** System unit 6 can be used for module expansion by adding a DD11-CK backplane, which will provide (2) quad and (2) hex slots.

\*Each MS11-LD or MS11-PB consumes one bus load in the PDP-11/24. Each MS11-LD or MS11-PB consumes no bus loads in the PDP-11/44.

# UNIBUS CPU Cabinets

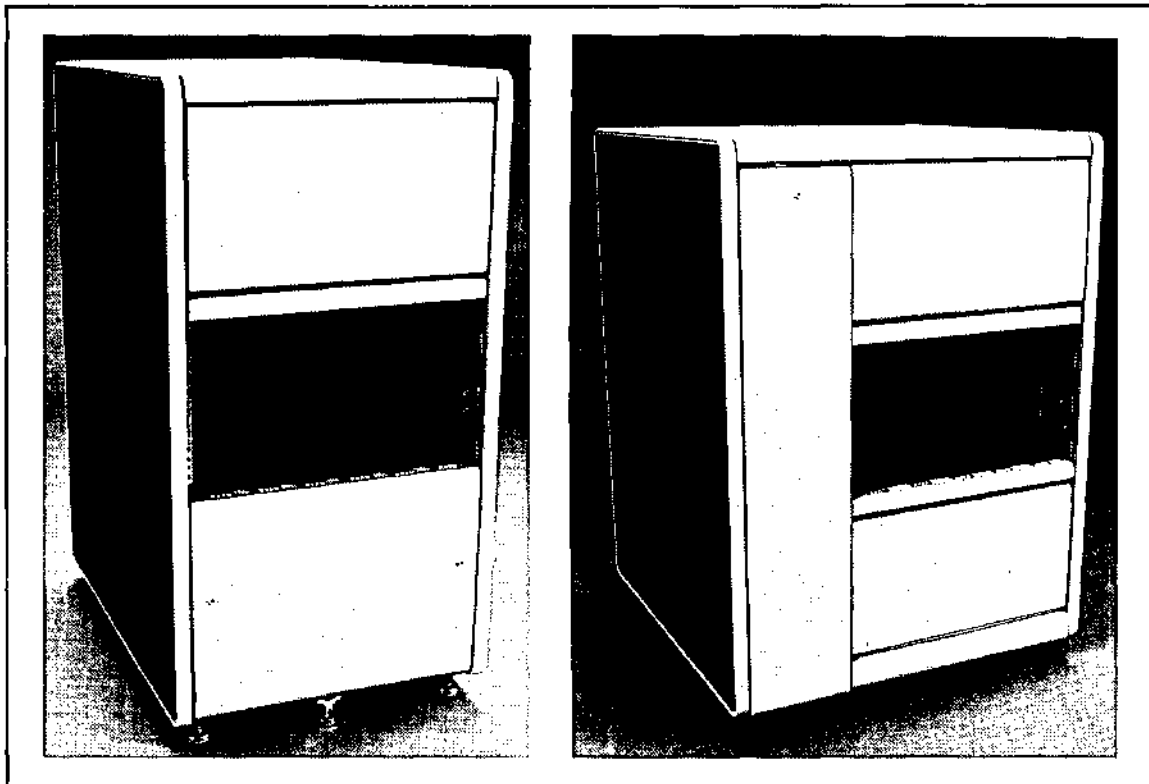

Two CPU cabinets are available for integrating the PDP-11/24 and PDP-11/44 CPU boxes with Digital's mass storage devices or non-Digital mounting boxes. These cabinets feature a centered, shielded enclosure and shielded cable duct that is routed to an I/O Connection Panel. When mounted in this shield and used with appropriate interfaces and I/O Connection Panel inserts, the PDP-11/24 and PDP-11/44 comply with FCC RF emission regulations as Class A systems. The top and bottom mounting spaces are not shielded, and only Class A compliant equipment should be mounted in them. Digital's disk subsystems are RF shielded at the box level, and may be mounted in these spaces. **Note:** Because of its depth, the RA60 disk subsystem cannot be mounted in this cabinet. It requires its own deep H9642-AP(AR) cabinet. BA11 expander boxes cannot be mounted in the CPU cab. The I/O is routed to the connection panel, which provides 12 panel units of mounting space.

The CPU cabinets are supplied with power controllers capable of furnishing 24 amps of 120VAC or 12 amps of 240VAC.

## Ordering Information:

**H9642-EA(EB)** CPU cabinet includes mounting space for a 26.6 cm (10.5 in) or 13.3 cm (5.25 in) CPU, one additional 26.6 cm (10.5 in) or 13.3 cm (5.25 in) device, and a battery backup unit. The I/O Connection Panel is included.

**H9645-EA(EB)** Wide CPU cabinet provides mounting space for a 26.6 cm (10.5 in) CPU and two additional 26.6 cm (10.5 in) or 13.3 cm (5.25 in) devices. Side mounting space is provided for the battery backup unit. The I/O Connection Panel is included. Because of AC power constraints, only one RA80 or RA81 disk subsystem may be mounted in this cabinet. The Digital disk subsystems which may be mounted in these cabinets include the RUA80-AA(AD), RUA81-AA(AD), RL211-AK, RX211-BK(BN), and the TU58-DA.

## Site Preparation Specifications:

### H9642-EA(EB)

- Height: 106 cm (41.7 in)
- Width: 53.9 cm (21.2 in)
- Depth: 80 cm (31.5 in)
- Weight: 91.7 kg (202 lb)
- Receptacles:  
NEMA #L5-30R (120VAC/60Hz),  
#6-15R (240VAC/50Hz)

### H9645-EA(EB)

- Height: 106 cm (41.7 in)
- Width: 73.6 cm (29 in)
- Depth: 80 cm (31.5 in)
- Weight: 117 kg (258 lb)
- Receptacles:  
NEMA #L5-30R (120VAC/60Hz),  
#6-15R (240VAC/50Hz)

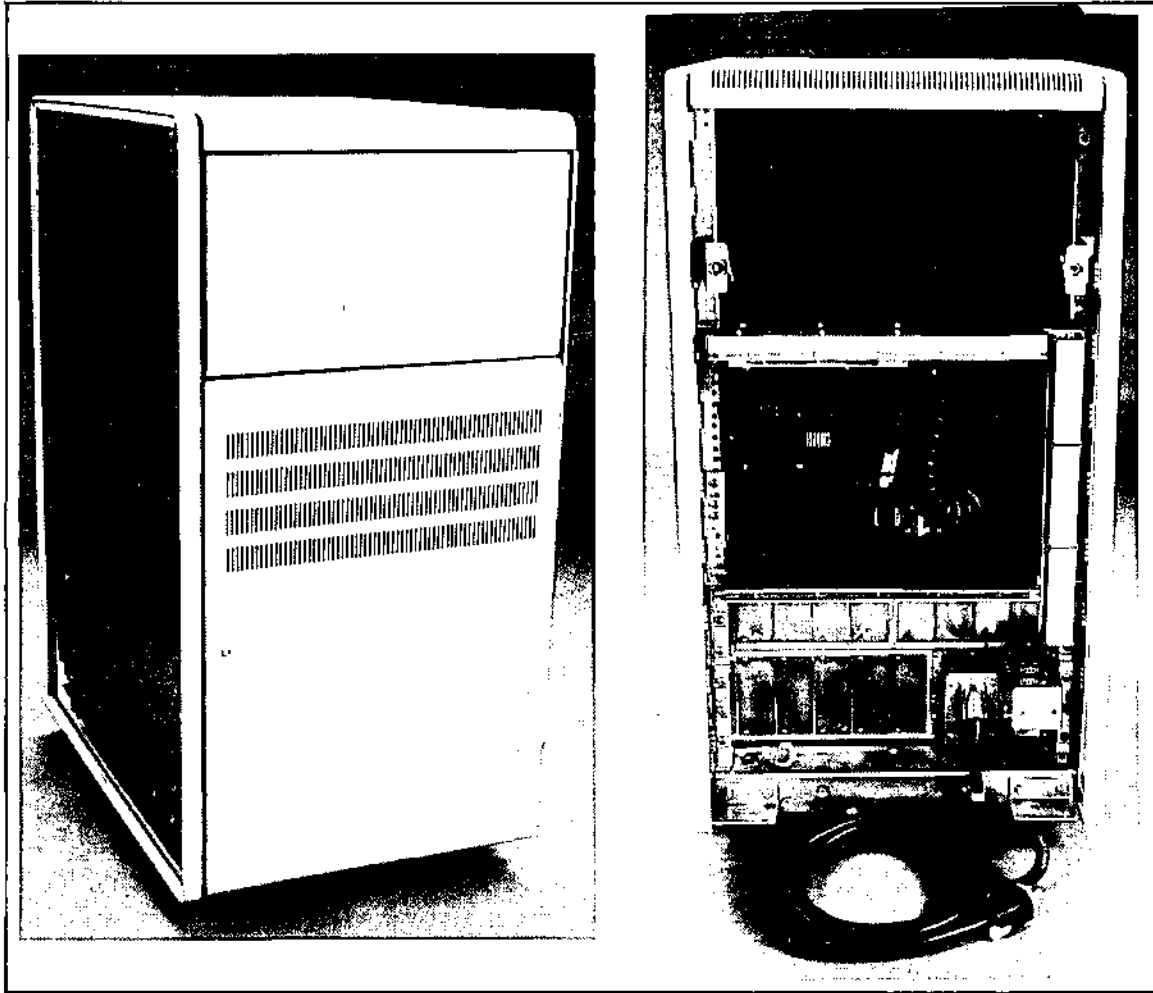

**H9642-FA(FB)** Partitioned expander cabinet provides mounting space for a BA11-KU(KV) UNIBUS expander box and one 26.6 cm (10.5 in) device. The expander box mounts in the RFI shielded central position, and together with a shielded cable duct and an I/O Connection Panel (13 panel units of space) provides an expansion enclosure for Digital options. The top 26.6 cm (10.5 in) mounting space is unshielded and can be used to mount any of the Digital disk subsystems listed for the UNIBUS CPU cabinets.

### Site Preparation Specifications:

- Height: 106 cm (41.75 in)
- Width: 52 cm (20.25 in)
- Depth: 80 cm (31.5 in)
- Weight: 68 kg (150 lbs)
- Receptacles:  
NEMA #L5-30R (120Vac/60Hz),  
#6-15R (240Vac/50 Hz)

# UNIBUS Expander Cabinets

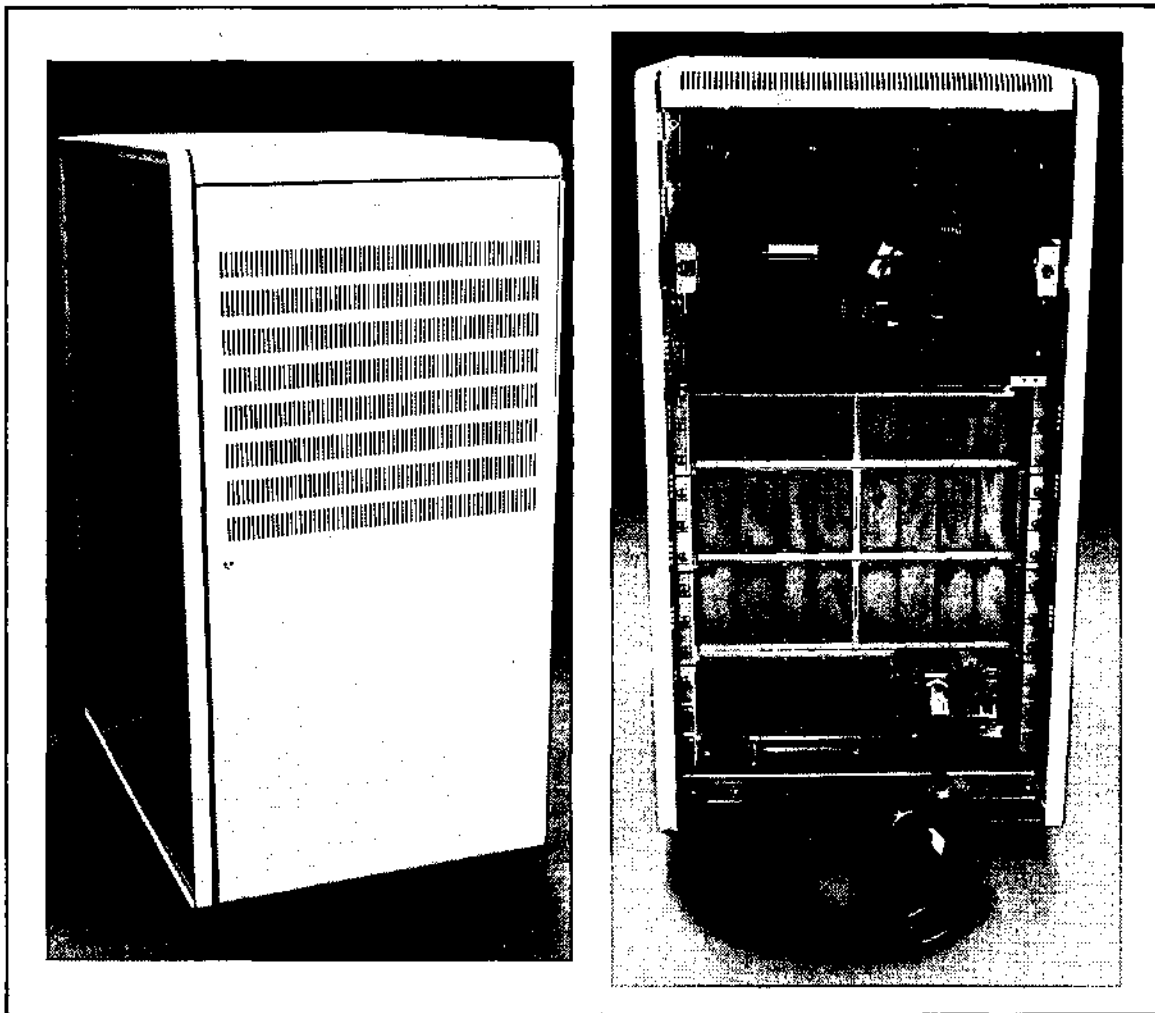

Expander cabinets are furnished without side panels. They are bolted to the right end of H9642 or H9645 CPU cabinets. The existing right side panel of the CPU cabinet is then used as the right side panel of the expander cabinet. A UNIBUS cable passes through a shielded port between the cabinets. I/O Connection Panel inserts for all options must be located in the same cabinet which contains the associated device controller interface. Expander cabinets are supplied with power controllers capable of furnishing 24 amps of 120VAC or 12 amps of 240VAC.

## Ordering Information:

**H9642-FC(FD)** Unpartitioned expander cabinet provides mounting space for a BA11-KU(KV) UNIBUS expander box and two I/O Connection Panels, for a total of 29 panel units of I/O connection space. No disk/tape options can be mounted in this cabinet.

## Site Preparation Specifications:

- Height: 106 cm (41.7 in)
- Width: 52 cm (20.2 in)
- Depth: 80 cm (31.5 in)
- Weight: 68 kg (150 lb)
- Receptacles:  
NEMA #L5-30R (120VAC/60Hz),  
#6-15R (240VAC/50Hz)

## Ordering Information:

<b>H9642-AP(AR)</b>	Top-loading cabinet for the RA60 removable disk subsystem. Allows mounting of any combination of RA60s, RA80s, and RA81s in the middle and bottom cabinet bays. The RA60, however, must be mounted in the top bay.
<b>H9642-BD(BE)</b>	Top-loading expansion cabinet for the RL01/RL02. Provides 53.3 cm (21 in) mounting space beneath the RL01/RL02.
<b>H9642-AS(AT)</b>	Cabinet for the RA80 or RA81 fixed-disk subsystem. Allows mounting of any combination of RA60s, RA80s, and RA81s in the middle and bottom cabinet bays. <b>Note:</b> The RA60 cannot be mounted in the top of the cabinet.

## Site Preparation Specifications:

### H9642-AP(AR) and H9642-AS(AT)

- Height: 106 cm (41.7 in)
- Width: 54.1 cm (21.3 in)
- Depth: 91.4 cm (36 in)
- Weight: Approximately 90.7 kg (200 lb)
- Receptacles:
  - NEMA #L5-30R (120VAC/60Hz).
  - #6-20R (240VAC/50Hz)

# Backplanes and Boxes

## Expansion Backplanes

- DD11-CK** Four-slot expansion backplane for use in BA11-KU(KV) expansion boxes or in PDP-11/24 and PDP-11/44 CPU boxes. Accommodates two hex and two quad modules. Requires one System Unit (SU) of space.
- DD11-DK** Nine-slot expansion backplane for use in BA11-KU(KV) expansion boxes or in PDP-11/24 and PDP-11/44 CPU boxes. Accommodates seven hex and two quad modules. Requires two System Units (SU) of space.

DD11-CK BACKPLANE

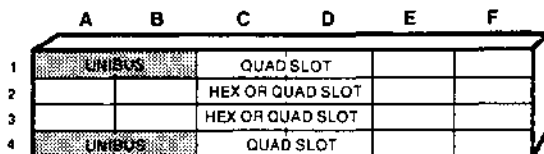

DD11-DK BACKPLANE

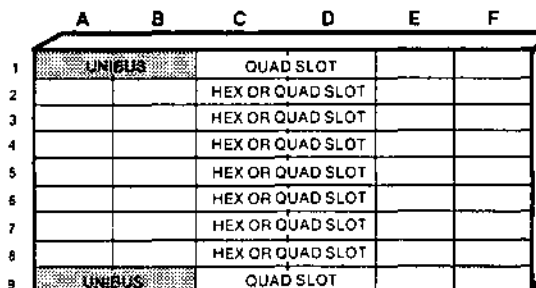

## Expansion Boxes

- BA11-KU(KV)** The BA11-KU(KV) is a cabinet-mountable 26.6 cm (10.5 in) expansion box with bezel and slides for use in expander cabinets. Fans located between the power supply and modules produce front to back cooling. It provides five system units of mounting space and is compatible with the DD11-CK/DK expansion backplanes. The power supply is rated at 32 amps @+5 V for SU 1-2, and 32 amps @+5 V for SU 3-5, 4 amps @+15 for SU 1-5, and 10 amps for @-15 V for SU 1-5. Includes BC11A-10 cable for connecting to CPU box. **Note:** Backplanes not included. For use in H9642 FA(FB), FC(FD) expander cabinets.

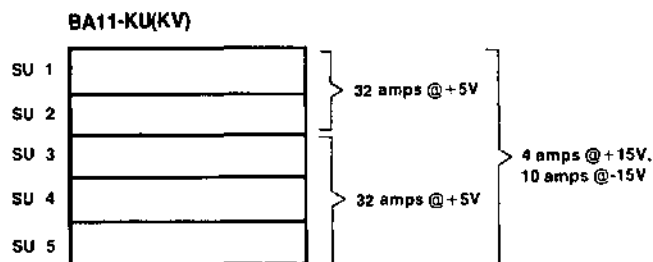





# 2 Options

When you select a system you must also select the hardware options that will best fit your application needs. For example, you may need to accommodate many users, or want to connect to a network of other computers to share resources. In these cases, you would need more terminals or communication interfaces. This extra load might also require increased processor power, additional memory, or more expansion space. The options you will need to complete or expand your system are described in this section.

Each Digital PDP-11 processor offers a floating point processor or floating point accelerator for applications that require a great deal of calculation. Several types of memory are available in varying increments to increase performance. To share resources and save on redundant system hardware, there are a wide variety of communication modules, both synchronous and asynchronous, to link your system to a network. There are options for digital and analog I/O. In addition, several environmental products are included which help to ensure reliable system performance.

Because you may order hardware options when you purchase a new system, or choose to add options at a later time to an installed system, we have implemented a new flexible option ordering plan. Communication and I/O Options can now be ordered as system options (installed at the factory) or as upgrade options (installed in the field).

The Options section includes both Q-bus options (for MICRO/PDP-11, PDP-11/23-PLUS, and PDP-11/23-S systems) and UNIBUS options (for PDP-11/24 and PDP-11/44 systems). Make sure you select from the correct category of options for your system.

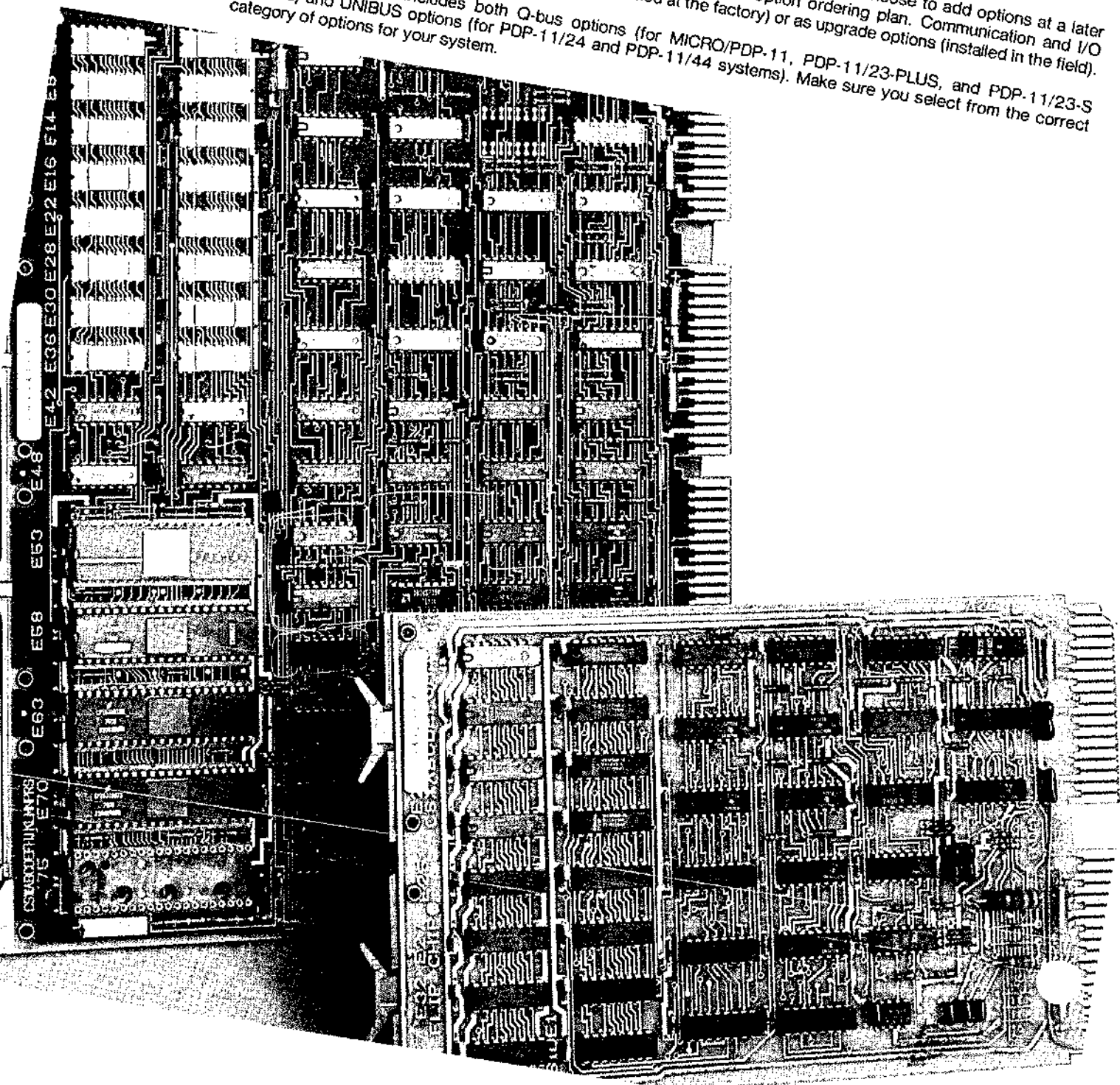

## Processor and Memory Options

Description	Q-bus	Page	UNIBUS	Page
Floating Point	KEF11-AA, FPF11	2-6	KEF11-AA, FPF11 FP11-F	2-6, 2-7
Commercial Instruction Set	KEF11-BB	2-6	KEF11-BB, KE44-A	2-6, 2-7
Memory	MSV11 MCV11	2-6	MS11, KT24	2-7

**Note:** Additional memories are described in Section 3—Components.

## Communication Options

Description	Q-bus	Page	UNIBUS	Page
Asynchronous/ Synchronous	KMV11, DLVE1 DLVJ1, DPV11 DUV11, DMV11	2-11, 2-9 2-9, 2-10 2-11, 2-10	DL11, DUP11 KMS11	2-12, 2-13 2-16
Asynchronous Multiplexer	DZV11	2-10	DZ11, DH11	2-13
DECnet Interface	DMV11, DPV11	2-10	DMR11, DMP11	2-14, 2-15
Ethernet			DEUNA	2-17
Statistical Multiplexers			DECmux, DFM	2-16

## Realtime I/O

Description	Q-bus	Page	UNIBUS	Page
Digital I/O	DRV11	2-20	DR11, DRU11 DRS11, DSS11	2-20, 2-21 2-20
Analog I/O	ADV11, AXV11, AAV11	2-21		
Programmable Realtime Clock	KWV11	2-22	KW11-P	2-22
IEEE 488 Interface	IEQ11	2-21	IEU11, IEC11	2-21

# New Option Ordering Information

---

## Flexible Ordering Plan for Communication and I/O Options

Options can be ordered when a system is purchased— **System Options**, or as upgrades to a system already installed in the field—**Upgrade Options**. System options are installed in a system at the factory, and upgrade options are installed in the field. Upgrade options will be available for use with both old style—unshielded cabinets, and with the new style—shielded cabinets designed to reduce potential EMI/RFI emissions.

The following section outlines this new ordering scheme for all Q-bus and UNIBUS communications and I/O options (order codes for processor and memory options will not be affected).

### System Options

To order the system version of an option, you need only specify a single option name on an order for a CPU. You will receive the option, with all appropriate cabling and bracket hardware, already installed on that CPU.

*Example (Communications Options)*

If you want a DECnet RS232-C interface for a PDP-11/44 , you would order a **DMR11-AP**.

#### **DMR11-AP**

**DMR11** = Generic option

**A** = RS232-C interface with full modem control

**P** = Factory-installed

*Example (Non-communications Options)*

If you want a 16-bit parallel interface for your PDP-11/23-PLUS, you would order a **DRV11-LP**.

#### **DRV11-LP**

**DRV11** = Generic option

**L** = Multifunction device

**P** = Factory-installed

# New Option Ordering Information

---

## Upgrade Options

To purchase an option as a field add-on to an existing system, you order the base option module together with the specific cabinet kit required to install the module on your CPU. A cabinet kit contains the unique cable, filter assembly, and any bracket hardware required to install the option in a specific cabinet or enclosure.

For mounting options in different cabinets, various length internal cables and mounting brackets will be required on different CPUs. Therefore, several different cabinet kits are available for one option.

UNIBUS options can be mounted in older, unshielded cabinets by ordering the cabinet kit that includes an adapter bracket. To determine whether your cabinet is shielded or unshielded, examine the back of the cabinet. A shielded cabinet will have metal panels with I/O connection panel inserts or blank metal plates mounted in the cutouts in these panels. An unshielded cabinet may have devices mounted in the back of the cabinet, but will not have complete coverage across the entire cabinet. The CPU box and disk enclosures are visible from the back of an unshielded cabinet.

The cabinet kits available for each option are described in **Section 2—Options**.

### *Example (Communications Options)*

If you want to add a 4-line multiplexer to an existing MICRO/PDP-11, you would order the following two options:

**DZV11-M** = Base option

**CK-DZV11-DB** = Cabinet kit to install a DZV11 on a MICRO/PDP-11

### *Example (Non-communications Options)*

If you want to add a 16-line parallel interface to an existing PDP-11/23-PLUS, you would order the following two options:

**DRV11-J** = Base option module

**CK-DRV11-KC** = Cabinet kit to install a DRV11-J on a PDP-11/23-PLUS

In summary, Q-bus and UNIBUS communication and I/O options can now be ordered either as system-integrated or field upgrade options. The order codes have been changed to reflect this new style of purchasing an option specifically designed to fit any PDP-11 processor in any enclosure you now own or plan to purchase.

An appendix has been added at the end of this catalog which translates the **old** option order codes to the **new** system-integrated and field-upgrade option order codes.

# Q-bus Processor Options & Memories

---

## Q-bus Processor Options

<b>FPF11</b>	Single- and double-precision fast floating point hardware option. This option is one quad module mounted adjacent to the CPU. Performs hardware operations on 32-bit and 64-bit floating point numbers. Provides up to 17 digits of precision. Provides integer-to-floating point conversions. Executes instructions approximately six times faster than the KEF11-AA.
<b>KEF11-AA</b>	Single- and double-precision floating point option. The microcode to implement this option resides in two chips on one 40-pin package. Performs microcode operations on 32-bit and 64-bit floating point numbers. Provides up to 17 digits of precision. Provides integer-to-floating point conversions. Mounts on the CPU board.
<b>KEF11-BB</b>	Commercial Instruction Set (CIS). Implements a set of 27 commercial instructions on a variety of data types, including character strings, packed decimal, and numeric formats. Mounts on the CPU board.

## Q-bus Memories

<b>MCV11-DC</b>	32 KB CMOS static Random Access Memory with on-board battery backup. This battery backup provides minimum data retention time of 50 days.
<b>MSV11-PK</b>	256 KB parity MOS memory.
<b>MSV11-PL</b>	512 KB parity MOS memory.

# UNIBUS Processor Options & Memories

## PDP-11/24 Processor Options and Memories

<b>FPF11</b>	Single- and double-precision fast floating point hardware option. This option is one quad module mounted adjacent to the CPU. Performs hardware operations on 32-bit and 64-bit floating point numbers. Provides up to 17 digits of precision. Provides integer-to-floating point conversions. Executes instructions approximately six times faster than the KEF11-AA.
<b>H775-A</b>	Battery backup for the 13.3 cm (5.25 in) PDP-11/24. This battery backup provides minimum data retention time of 20 minutes.
<b>H7750-BA(BD)</b>	Battery backup for the 26.6 cm (10.5 in) PDP-11/24. This battery backup provides minimum data retention time of 20 minutes.
<b>KEF11-AA</b>	Single- and double-precision floating point option. The microcode to implement this option resides in two chips on one 40-pin package. Performs microcode operations on 32-bit and 64-bit floating point numbers. Provides up to 17 digits of precision. Provides integer-to-floating point conversions. Mounts on the CPU board.
<b>KEF11-BB</b>	Commercial Instruction Set (CIS) for the PDP-11/24. Performs a set of 27 commercial instructions on a variety of data types, including character strings, packed decimal, and numeric formats. Mounts on the CPU board.
<b>MS11-PB</b>	1 MB ECC MOS memory for the PDP-11/24.
<b>KT24</b>	Physical Address Extension (PAX) module allows memory expansion up to 1 MB with a 13.3 cm (5.25 in) CPU box and up to 4 MB with a 26.6 cm (10.5 in) CPU box. <b>Note:</b> The KT24 must mount in the second hex slot in the CPU backplane, next to the processor.

## PDP-11/44 Processor Options and Memories

<b>FP11-F</b>	Floating Point Processor for the PDP-11/44 with 46 floating point instructions. Performs hardware operations on 32-bit and 64-bit floating point numbers providing up to 17 digits of precision as well as integer to floating point conversions. Mounts in a dedicated slot in the PDP-11/44 backplane.
<b>H7750-BA(BD)</b>	Battery backup for the PDP-11/44. This battery backup provides minimum data retention time of 20 minutes.
<b>KE44-A</b>	Commercial Instruction Set (CIS) processor for the PDP-11/44. Performs 27 commercial instructions on a variety of data types, including character strings, packed decimal and numeric formats. Mounts in adjacent slots in the PDP-11/44 backplane.
<b>MS11-PB</b>	1 MB ECC MOS memory for the PDP-11/44.

# Communication & Realtime I/O Options

---



PDP-11 systems have set the computer industry standard for ease and flexibility of interconnection: to user terminals, to other computers, and to special purpose devices. This section describes asynchronous and synchronous communications interfaces, parallel digital and sensor-based interfaces, programmable clocks, and a variety of interconnecting cables. These options make it easy for you to connect your PDP-11 into an information processing system with both local and, through the use of modems and communication lines, remotely located equipment.

Digital's operating system software fully supports most of the devices described in this section. Optional software products, described in Section 8—**Networking**, support DECnet, Internets, and Packetnet operation. These networks can provide you with economical resource sharing, as well as information exchange between Digital systems and systems of other manufacturers.

# Q-bus Communication Options

Order codes for the options that follow are in the new format. Make sure you select the correct order code designation to indicate whether you want the system or upgrade version of the option.

## Asynchronous Interfaces

**DLVE1** is an asynchronous, RS232-C, one-line interface (formerly named DLV11-E). This dual-sized module is used to attach one asynchronous device to Q-bus computers. The DLVE1 moves data under program control between the Q-bus and a serial communication line. The DLVE1 offers modem control, program or jumper selectable line speeds from 50 to 19,200 b/s, split transmit and receive speeds, and is compatible with DF01, DF02, DF03 modems and Bell 103, 113, 202C, 202D, and 212 modems and equivalents. An external cable is not included. BC22D-xx is recommended for connection to terminals; BC22E-xx and BC22F-xx are recommended for connection to modems.

### Ordering Information:

- DLVE1-DP**            **System option.** Includes module, internal cables and I/O Connection Panel insert. This option must be ordered with the system in which it is to be installed.
- DLVE1-M**            **Upgrade option.** Includes base module only. For system installation select one of the following cabinet kits:
- CK-DLVE1-DA**      Cabinet kit. For use with (PDP-11/23-S) BA11-MA(MB) box.
- CK-DLVE1-DB**      Cabinet kit. For use with (MICRO/PDP-11) BA23 box.
- CK-DLVE1-DC**      Cabinet kit. For use with (PDP-11/23-PLUS) H349 panel.

**DLVJ1** is a four-line EIA/CCITT asynchronous interface without modem control (formerly named DLV11-J). It is used to support up to four asynchronous devices to Q-bus computers. The DLVJ1 is a dual-size, double-buffered module that moves data under program control between the Q-bus and serial communication lines. It features four independent serial line interfaces with consecutive bus device and vector assignments. Each channel can be configured for RS232-C, RS422, or RS423 interfaces, jumper selectable line speeds from 150 to 38.4 KB/s, seven or eight data bits and one or two stop bits. It is compatible with DF01, DF02, DF03, Bell 103, 113 or equivalent modems. The external cable is not included. BC22D-xx is recommended for connection to terminals; BD22E-xx and BC22F-xx are recommended for connection to modems.

### Ordering Information:

- DLVJ1-LP**            **System option.** Includes module, internal cables, and I/O Connection Panel insert. This option must be ordered with the system in which it is to be installed.
- DLVJ1-M**            **Upgrade option.** includes base module only. For system installation select external cables and one of the following cabinet kits:
- CK-DLVJ1-LA**      Cabinet kit. For use with (PDP-11/23-S) BA11-MA(MB) box.
- CK-DLVJ1-LB**      Cabinet kit. For use with (MICRO/PDP-11) BA23 box.
- CK-DLVJ1-LC**      Cabinet kit. For use with (PDP-11/23-PLUS) H349 panel.

**DLVK1-H** is an EIA to 20mA converter with BC21A-03 cable for connection to the DLVJ1 (formerly named DLV11-K). It is a self-contained box which mounts outside of the CPU cabinet. Cables not included for connection to equipment. Use standard Digital 20mA cabling such as BC05F.

- DLVK1-H8**            EIA to 20 mA converter.



# Q-bus Communication Options

---

**DZV11** is a four-line asynchronous, program-controlled multiplexer with modem control on all lines. It is a quad-size option for use on Q-bus processors. The DZV11 supports programmable speeds up to 9600 b/s. It can be used with the Q-bus processor in a variety of applications that include data concentration, realtime processing, and cluster controlling. The module provides EIA interface levels and enough data set control to permit dial-up (auto-answer) operation with modems using full-duplex operation such as DF01, DF02, DF03, and Bell models 103, 113, 212 or equivalent. The DZV11 does not support half-duplex operations on modems. Cables are not included. BC22D-xx is recommended for connection to terminals; BC22E-xx and BC22F-xx are recommended for connection to modems.

## Ordering Information:

<b>DZV11-DP</b>	<b>System option.</b> Includes module, internal cables and I/O Connection Panel insert. This option must be ordered with the system in which it is to be installed.
<b>DZV11-M</b>	<b>Upgrade option.</b> Includes base module only. For system installation select the appropriate external cables and one of the following cabinet kits:
<b>CK-DZV11-DA</b>	Cabinet kit for use with (PDP-11/23-S) BA11-MA(MB) box.
<b>CK-DZV11-DB</b>	Cabinet kit for use with (MICRO/PDP-11) BA23 box.
<b>CK-DZV11-DC</b>	Cabinet kit for use with (PDP-11/23-PLUS) H349 panel.

## Synchronous Interfaces

**DPV11** is a single-line, program-controlled, double-buffered communications device that interfaces any Q-bus-based processor to a serial synchronous line. The DPV11 is suited for interfacing to medium-speed synchronous lines for packet switching, remote batch, remote data collection, remote concentration, and network applications. The unit is capable of handling, under program control, a wide variety of protocols, including byte-oriented protocols such as DDCMP and BISYNC and bit-oriented protocols such as HDLC and ADCCP. The option is one dual sized module. It operates in full or half duplex. Includes BC22F-25 modem cable.

## Ordering Information:

<b>DPV11-AP</b>	<b>System option.</b> Includes module, internal cables and I/O Connection Panel insert. This option must be ordered with the system in which it is to be installed.
<b>DPV11-M</b>	<b>Upgrade option.</b> Includes base module only. For system installation select one of the following cabinet kits:
<b>CK-DPV11-AA</b>	Cabinet kit. For use with (PDP-11/23-S) BA11-MA(MB) box.
<b>CK-DPV11-AB</b>	Cabinet kit. For use with (MICRO/PDP-11) BA23 box.
<b>CK-DPV11-AC</b>	Cabinet kit. For use with (PDP-11/23-PLUS) H349 panel.

**DMV11** is an intelligent microprocessor-based synchronous DECnet interface that supports full- or half-duplex Direct Memory Access (DMA) data transfer in either point-to-point or multipoint communications. Depending on operating system and layered software implementation, the DMV11 will support up to 12 multipoint tributaries. The controller microcode handles all DDCMP protocol processing, thereby offloading the central processor. In point-to-point operation the DMV11 can communicate with a DMC11, DUP11, DPV11, DMR11, DMP11, or DMV11 device operating in the same mode. In multipoint operation the complementary devices must be DMP11s or DMV11s. It supports RS423-A operation to a maximum of 56 KB/s, and RS232-C, CCITT V.24, or CCITT V.28 operation at 19.2 KB/s. External cables not included.

## Ordering Information:

<b>DMV11-AP</b>	<b>System option.</b> RS232-C/CCITT V.28 interface. Includes module, internal cables and I/O Connection Panel insert. This option must be ordered with the system in which it is to be installed. Requires BC22E or BC22F external cable.
<b>DMV11-FP</b>	<b>System option.</b> RS423-A/CCITT V.24 interface. Requires a BC55D external cable.
<b>DMV11-8P</b>	<b>System option.</b> CCITT V.35/DDS interface. Requires a BC22E external cable.
<b>DMV11-CP</b>	<b>System option.</b> Integral modem. Requires a BC55S or BC55T external cable. <b>Note:</b> Earlier versions of this option used a plastic cable connector. To connect the BC55S or BC55T to the older BC55M or BC55N cables, BC56A/B/C/D adapter cables are available.

# Q-bus Communication Options

<b>DMV11-M</b>	<b>Upgrade option.</b> RS232-C or RS423/RS449 interfaces. Includes base module only. For system installation select the appropriate external cable and one of the following cabinet kits:
<b>CK-DMV11-AA</b>	RS232-C cabinet kit. For use with (PDP-11/23-S) BA11-MA(MB) box.
<b>CK-DMV11-AB</b>	RS232-C cabinet kit. For use with (MICRO/PDP-11) BA23 box.
<b>CK-DMV11-AC</b>	RS232-C cabinet kit. For use with (PDP-11/23-PLUS) H349 panel.
<b>CK-DMV11-FA</b>	RS423/RS449 cabinet kit. For use with (PDP-11/23-S) BA11-MA(MB) box.
<b>CK-DMV11-FB</b>	RS423/RS449 cabinet kit. For use with (MICRO/PDP-11) BA23 box.
<b>CK-DMV11-FC</b>	RS423/RS449 cabinet kit. For use with (PDP-11/23-PLUS) H349 panel.
<b>DMV11-N</b>	<b>Upgrade option.</b> V.35 and Integral Modem interfaces. Select the appropriate external cables and one of the following cabinet kits:
<b>CK-DMV11-BA</b>	V.35 cabinet kit. For use with (PDP-11/23-S) BA11-MA(MB) box.
<b>CK-DMV11-BB</b>	V.35 cabinet kit. For use with (MICRO/PDP-11) BA23 box.
<b>CK-DMV11-BC</b>	V.35 cabinet kit. For use with (PDP-11/23-PLUS) H349 panel.
<b>CK-DMV11-CA</b>	Integral Modem cabinet kit. For use with (PDP-11/23-S) BA11-MA(MB) box.
<b>CK-DMV11-CB</b>	Integral Modem cabinet kit. For use with (MICRO/PDP-11) BA23 box.
<b>CK-DMV11-CC</b>	Integral Modem cabinet kit. For use with (PDP-11/23-PLUS) H349 panel.

The DUV11 single-line, double-buffered program-controlled communications interface is used to establish a data communications link between any Q-bus-based processor and a Bell 201 synchronous modem or equivalent. The module is fully programmable with respect to sync characters and parity selection. The DUV11 is designed for applications using character-oriented protocols, and controls the modem for half- or full-duplex operation. It also interfaces synchronous and isochronous communications data (isochronous operation is essentially asynchronous data transmission over a synchronous modem). It transmits EIA CITT data at rates up to 9600 b/s.

## Ordering Information:

<b>DUV11-AP</b>	<b>System option.</b> Includes module, internal cables and I/O connection panel insert. This option must be ordered with the system in which it is to be installed.
<b>DUV11-M</b>	<b>Upgrade option.</b> Includes base module only. For system installation, select one of the following cabinet kits.
<b>CK-DUV11-AA</b>	Cabinet kit. For use with (PDP-11/23-S) BA11-MA(MB) box.
<b>CK-DUV11-AB</b>	Cabinet kit. For use with (MICRO/PDP-11) BA23 box.
<b>CK-DUV11-AC</b>	Cabinet kit. For use with (PDP-11/23-PLUS) H349 panel.

**KMV11-A** is a single-line synchronous/asynchronous programmable communications interface. It supports FDX/HDX Direct Memory Access (DMA) data transfer in point-to-point or multipoint operation. The interface is controlled by an on-board DCT11-AA microprocessor with 32K of RAM, enabling soft-loaded microcode to handle protocol processing. Under such microcode's control, the device is capable of offloading the CPU, while handling a variety of bit-or-byte-oriented protocols. Software currently available for RSX-11M/M-PLUS implementation of HDLC/SDLC (frame level only) communications applications (QJS32/39).

## Ordering Information:

<b>KMV11-AA</b>	Supports RS232-C or CCITT V.28 operation at 19.2 KB/s. For use on PDP-11/23-PLUS systems. External cable not included, BC22F-xx is the recommended cable.
<b>KMV11-AE</b>	Supports RS449/422A or CCITT V.11 operation to a maximum of 64 KB/s. For use on PDP-11/23-PLUS systems. External cable not available from Digital.
<b>KMV11-AF</b>	Supports RS449/423A or CCITT V.10 operation to a maximum of 19.2 KB/s. For use on PDP-11/23-PLUS systems. External cable not available from Digital.

# UNIBUS Communication Options

---

The order codes for the following options follow the new format. Be sure to specify the correct order code designation for system or upgrade options and cabinet kits.

## Single-Line Asynchronous Interfaces

**DL11** single-line asynchronous interfaces provide local and remote interconnection of the UNIBUS to terminals and other computer systems. They feature selectable character size, parity, stop bit(s), and speed of operation, operating in full-duplex or half-duplex mode.

### Ordering Information:

<b>DL11-AP</b>	<b>System option</b> (formerly DL11-E). EIA/CCITT interface with modem control, jumper-selectable options. Compatible with DF01, DF02, DF03 and Bell 103, 113, 202, or 212 modems or equivalent. Includes BC22D-25 cable. <b>Note:</b> Customer must specify data rate from the following speeds: 50, 75, 110, 150, 134.5, 200, 300, 600, 1200, 1800, 2400, 4800, or 9600 b/s.
<b>DL11-HP</b>	<b>System option</b> (formerly DL11-WA). 20mA serial line interface and line frequency realtime clock. Switch-selectable options. Includes BC05M-04 cable for terminal connection. <b>Note:</b> Data rates are switch-selectable and must be specified from the following speeds: 110, 150, 300, 600, 1200, 2400, 4800, or 9600 b/s. Character formats are switch-selectable.
<b>DL11-DP</b>	<b>System option</b> (formerly DL11-WB). EIA/CCITT RS232-C serial line interface and line frequency realtime clock without modem control. Switch-selectable options. Includes BC05C-25 cable. <b>Note:</b> Data rates are switch-selectable and must be specified from the following speeds: 110, 150, 300, 600, 1200, 2400, 4800, or 9600 b/s. Character formats are switch-selectable.
<b>DL11-M</b>	<b>Upgrade option</b> (formerly DL11-E). RS232-C interface and modem control. Includes base module only. For system installation select the appropriate external cables and one of the following cabinet kits:
<b>CK-DL11-AD</b>	Cabinet kit. For use with (PDP-11/24 and -11/44) shielded cabinets.
<b>CK-DL11-A1</b>	Cabinet kit. For use with unshielded cabinet models. Adapter bracket included.
<b>DL11-N</b>	<b>Upgrade option</b> (formerly DL11-W). RS232-C and 20mA interfaces without modem control. Includes base module only. For system installation select the appropriate external cables and one of the following cabinet kits:
<b>CK-DL11-DD</b>	RS232-C cabinet kit. For use with (PDP-11/24 and -11/44) shielded cabinets.
<b>CK-DL11-D1</b>	RS232-C cabinet kit. For use with unshielded cabinet models. Adapter bracket included.
<b>CK-DL11-HD</b>	20mA cabinet kit. For use with (PDP-11/24 and -11/44) shielded cabinets.
<b>CK-DL11-H1</b>	20mA cabinet kit. For use with unshielded cabinet models. Adapter bracket included.

## Asynchronous Multiplexers

**DZ11** asynchronous serial communications interfaces can be used for local or remote connection of UNIBUS systems to as many as 8 terminals or to another system. They feature programmable speeds (up to 9600 b/s) and format on a per-line basis, operating at full-duplex.

### Ordering Information:

<b>DZ11-DP</b>	<b>System option.</b> Eight-line multiplexer with distribution panel for EIA/CCITT terminals. Includes modem control for use with DF02, DF03 and Bell 103, 113, or 212 modems or equivalent. External cables for terminals not included; for connection to modems one BC22E-xx is recommended per line. For local connection of EIA/CCITT terminals, order one BC22D-xx per line.
<b>DZ11-HP</b>	<b>System option.</b> Eight-line multiplexer for use with 20mA current loop terminals. Terminal cables not included; order one BC04R-xx cable per line for connection of 20mA terminals.
<b>DZ11-M</b>	<b>Upgrade option.</b> RS232-C interface. Includes base module only. For system installation, select the appropriate external cables and one of the following cabinet kits:
<b>CK-DZ11-DD</b>	RS232-C cabinet kit. For use with (PDP-11/24 and -11/44) shielded cabinets.
<b>CK-DZ11-D1</b>	RS232-C cabinet kit. For use with unshielded cabinet models. Adapter bracket included.
<b>DZ11-N</b>	<b>Upgrade option.</b> 20mA interface. Includes base module only. For system installation, select the appropriate external cables and one of the following cabinet kits:
<b>CK-DZ11-HD</b>	20mA cabinet kit. For use with (PDP-11/24 and -11/44) shielded cabinets.
<b>CK-DZ11-H1</b>	20mA cabinet kit. For use with unshielded cabinet models. Adapter bracket included.

**DH11** 16-line asynchronous DMA multiplexers are used for local or remote connection of UNIBUS systems to EIA/CCITT terminals. Operating in full- or half-duplex mode, they support per-line program control for data rate (up to 9600 b/s), character size, stop bit, and transmission mode. Split-speed transmit and receive rates are supported.

### Ordering Information:

<b>DH11-AP</b>	<b>System option.</b> Includes modem control. External cables not included; for connection to modems one BC22E-xx is recommended per line; for local connection of EIA/CCITT terminals, order one BC22D-xx per line.
<b>DH11-DP</b>	<b>System option.</b> Does not include modem control. External cables not included; for local connection of EIA/CCITT terminals, order one BC22D-xx per line.
<b>DH11-M</b>	<b>Upgrade option.</b> RS232-C interface. Includes base module only. For system installation, select the appropriate external cables and one of the following cabinet kits:
<b>CK-DH11-AD</b>	RS232-C cabinet kit. For use with (PDP-11/24 and -11/44) shielded cabinets.
<b>CK-DH11-A1</b>	RS232-C cabinet kit. For use with unshielded cabinet models. Adapter bracket included.
<b>DH11-N</b>	<b>Upgrade option.</b> 20mA interface. Includes base module only. For system installation, select the appropriate external cables and one of the following cabinet kits:
<b>CK-DH11-DD</b>	20mA cabinet kit. For use with (PDP-11/24 and -11/44) shielded cabinets.
<b>CK-DH11-D1</b>	20mA cabinet kit. For use with unshielded cabinet models. Adapter bracket included.

## Single-Line Synchronous Interface

**DUP11** full- or half-duplex synchronous interface can be programmed to handle 8-bit character-oriented protocols such as DDCMP and BISYNC and bit-oriented protocols such as SDLC and HDLC. The hardware calculates CRC-16 when using DDCMP, and CRC/CCITT when using bit-oriented protocols. Normally used for RJE applications.

<b>DUP11-AP</b>	<b>System option.</b> Interfaces to Bell 200 series modems or equivalent at speeds up to 9600 b/s. Includes data set control and BC22F-25 cable for modem connection.
<b>DUP11-M</b>	<b>Upgrade option.</b> includes only base module. For system installation, select one of the following cabinet kits:
<b>CK-DUP11-AD</b>	Cabinet kit. For use with (PDP-11/24 and -11/44) shielded cabinets.
<b>CK-DUP11-A1</b>	Cabinet kit. For use with unshielded cabinet models. Adapter bracket included.

# UNIBUS Communication Options

**DMR11** is a DECnet point-to-point interface. The high-performance microprocessor-based option implements DDCMP protocol in hardware. It is used for local system interconnection or for connection to external modems for remote networking. A DMR11 can be used to communicate with another DMR11 or a DMV11 or DMP11, or other DDCMP microprocessor-based interface, or to some other synchronous interface with software implementation of DDCMP V3.1 or 4.0. Both half- and full-duplex operation are supported. For local operation at full duplex, two cables of the same type are needed.

## Ordering Information:

- DMR11-AP**      **System option.** Interfaces to RS232-C synchronous modems (Bell series 200 compatible) at speeds up to 19.2 KB/s. Includes data set control. External cable not included; order BC22E-xx cable.
- DMR11-FP**      **System option.** Interfaces to RS423/CCITT V.24 synchronous modems at speeds up to 56 KB/s. Includes data set control. External cable not included; order BC55D-xx cable.
- DMR11-BP**      **System option.** Interfaces to CCITT V.35/DDS synchronous modems (Bell 500A L1/5 or equivalent) at speeds up to 1 MB/s. Includes data set control. Includes BC05Z-25 cable for modem connection.
- DMR11-CP**      **System option.** Includes integral modem, for local interconnection. Supports switch-selectable speeds over the following distances:

Frequency	BC55S Triaxial Cable	BC55T Twinaxial Cable
1 MB/s	1.8 km 6000 ft	Not Recommended
500 KB/s	2.1 km 7000 ft	Not Recommended
250 KB/s	2.4 km 8000 ft	Not Recommended
56 KB/s	Not Recommended	4.8 km 16,000 ft

External cables not included; Requires BC55S or BC55T external cable. **Note:** Earlier versions of this option used a plastic cable connector. To connect the BC55S or BC55T to the earlier BC55N and BC55M cables, BC56A/B/C/D adapter cables are available. See the Communication Cable Chart in this section.

- DMR11-EP**      **System option.** Interfaces to RS422/CCITT V.24 synchronous modems, supports speeds up to 1 MB/s (FDX). Includes data set control for switched network operation. External cable not included; cable not available through Digital.
- DMR11-M**      **Upgrade option.** Includes base module only. For system installation, select the appropriate external cable and one of the following cabinet kits:
- CK-DMR11-AD**    RS232-C cabinet kit. For use with (PDP-11/24 and -11/44) shielded cabinets.
- CK-DMR11-A1**    RS232-C cabinet kit. For use with unshielded cabinets. Adapter bracket included.
- CK-DMR11-BD**    V.35 cabinet kit. For use with (PDP-11/24 and -11/44) shielded cabinets.
- CK-DMR11-B1**    V.35 cabinet kit. For use with unshielded cabinets. Adapter bracket included.
- CK-DMR11-CD**    Integral modem cabinet kit. For use with (PDP-11/24 and -11/44) shielded cabinets.
- CK-DMR11-C1**    Integral modem cabinet kit. For use with unshielded cabinets. Adapter bracket included.
- CK-DMR11-ED**    RS422/RS449 cabinet kit. For use with (PDP-11/24 and -11/44) shielded cabinets.
- CK-DMR11-E1**    RS422/RS449 cabinet kit. For use with unshielded cabinets. Adapter bracket included.
- CK-DMR11-FD**    RS423/RS449 cabinet kit. For use with (PDP-11/24 and -11/44) shielded cabinets.
- CK-DMR11-F1**    RS423/RS449 cabinet kit. For use with unshielded cabinets. Adapter bracket included.

# UNIBUS Communication Options

## Multipoint Synchronous Interfaces

**DMP11** is a DECnet point-to-point or multipoint interface. The microprocessor-based option implements DDCMP protocol in hardware. It is used for local or remote communications. It operates in full- or half-duplex mode. Depending on operating system and layered software, DMP11s will support up to 32 tributaries. In multipoint operation the complementary devices must be DMP11s, DMV11s or, on VAX systems, DMF32s (as tributaries only). In point-to-point communication, the DMP11 can be used to communicate with any other synchronous interface which implements DDCMP Version 3.1 or 4.0.

### Ordering Information:

- DMP11-AP**      **System option.** Interfaces to RS232-C synchronous modems (Bell series 200 compatible) at speeds up to 19.2 KB/s. Includes data set control. External cable not included; order BC22E-xx cable.
- DMP11-FP**      **System option.** Interfaces to RS423/CCITT V.24 synchronous modems at speeds up to 56 KB/s. Includes data set control. External cable not included; order BC55D-xx cable.
- DMP11-BP**      **System option.** Interfaces to CCITT V.35/DDS synchronous modems (Bell 500A L1/5 or equivalent) at speeds up to 56 KB/s. Includes data set control. Includes BC05Z-25 cable for modem connection.
- DMP11-CP**      **System option.** Includes integral modem, for local interconnection. Supports switch selectable speeds; at the following distances, maximum speeds supported are:

Frequency	BC55S Triaxial Cable	BC55T Twinaxial Cable
1 MB/s	1.8 km 6000 ft	Not Recommended
500 KB/s	2.1 km 7000 ft	Not Recommended
250 KB/s	2.4 km 8000 ft	Not Recommended
56 KB/s	Not Recommended	4.8 km 16,000 ft

External cables not included; Requires BC55S or BC55T external cable. **Note:** Earlier versions of this option used a plastic cable connector. To connect the BC55S or BC55T to the earlier BC55N and BC55M cables, BC56A/B/C/D adapter cables are available. See the Communication Cables Chart in this section.

- DMP11-EP**      **System option.** Interfaces to EIA RS422/CCITT V.24 synchronous modems, supports speeds up to 1 MB/s (HDX) or 500 KB/s (FDX). Includes data set control for switched network operation. External cable not included; cable not available through Digital.
- DMP11-M**      **Upgrade option.** Includes base module only. For system installation, select one of the following cabinet kits and the appropriate external cable.
- CK-DMP11-AD**    RS232-C cabinet kit. For use with (PDP-11/24 and -11/44) shielded cabinets.
- CK-DMP11-A1**    RS232-C cabinet kit. For use with unshielded cabinets. Adapter bracket included.
- CK-DMP11-BD**    V.35 cabinet kit. For use with (PDP-11/24 and -11/44) shielded cabinets.
- CK-DMP11-B1**    V.35 cabinet kit. For use with unshielded cabinets. Adapter bracket included.
- CK-DMP11-CD**    Integral modem cabinet kit. For use with (PDP-11/24 and -11/44) shielded cabinets.
- CK-DMP11-C1**    Integral modem cabinet kit. For use with unshielded cabinets. Adapter bracket included.
- CK-DMP11-ED**    RS422/RS449 cabinet kit. For use with (PDP-11/24 and -11/44) shielded cabinets.
- CK-DMP11-E1**    RS422/RS449 cabinet kit. For use with unshielded cabinets. Adapter bracket included.
- CK-DMP11-FD**    RS423/RS449 cabinet kit. For use with (PDP-11/24 and -11/44) shielded cabinets.
- CK-DMP11-F1**    RS423/RS449 cabinet kit. For use with unshielded cabinets. Adapter bracket included.

# UNIBUS Communication Options

---

## Multipoint Parallel Interface

### PCL11-B

The Parallel Communications Link (PCL11-B) is a multidrop computer link used to connect up to 16 processors to form a local distributed network. Full duplex interfaces, residing in each CPU, are interconnected by a single high speed bus which can operate at speeds up to 1 MB depending on the bus length. The maximum bus length is 91 m (300 ft). CRC and word parity error detection are supported by the hardware. **Note:** BC17U-14 and BC17T-xx cables are included. Specify the BC17T-xx length as a note on the order form. Lengths are available in increments of 1.5 m (5 ft) up to 18.2 m (60 ft), as well as 25.9 m (85 ft), 30.4 m (100 ft), 39.6 m (130 ft), and 85.3 m (280 ft).

## Auxiliary Communications Microprocessors

### KMS11-BD

The KMS11-BD is used in a communications environment as a high speed, intelligent front-end processor which offloads the host CPU of communication functions. Through the use of direct memory access, the KMS11 efficiently multiplexes as many as 8 synchronous communications lines into the processor. The KMS11 offers bit or byte oriented operation in either full or half-duplex mode. The hardware calculates CRC-16 when using byte protocols, and CRC/CCITT, when using bit protocols. Data transmission and reception is fully controlled by the microprocessor part of KMS11, thus allowing full level 2 offloading for higher processor efficiency. The microprocessor is controlled by a 4K word memory (writable control store) which is loaded at system initialization time with the appropriate micro-program. Current applications utilize the Digital PSI package and a full X.25 link level package. A software tools package is available for users to create their own custom microcode for custom networking applications. The KMS11 interfaces to RS232-C and MIL-188-144 unbalanced. Line speeds are dependent on the software application. Using Digital PSI software—2 lines at 9600 KB/s; using X.25 link level software—4 lines at 56 Kbaud and 8 lines at 19.2 Kbaud. Includes a DD11-DK double system unit and all internal cables. External cables are not included.

### KMS11-BE

Same as KMS11-BD but without the DD11-DK double system unit.

## Statistical Multiplexers

### DECmux

The DECmux Terminal Concentrator is comprised of a DZS11-EA and VT1XX-EB modules. DECmux is a statistical multiplexer that connects up to eight asynchronous terminals to a PDP-11 via a single synchronous, full-duplex communication link. The eight terminals can be configured in one cluster, or split into two clusters using the route-through capability. Each cluster includes a VT1XX-EB which mounts into a VT100-AA or -AB and concentrates the data from the terminals onto the main or route-through links. Both the main and route-through links can be made using dedicated lines and modems or by means of DECmux's RS422 long line capability. The main and route-through links do not have to be made the same way and each can operate up to 19.2 Kbaud. All the terminals in the DECmux network can operate at speeds of up to 9600 baud. The DZS11-EA host interface is a single hex module to which the main link is directly connected eliminating the need for distribution panels. DECmux is DZ11 compatible, therefore it interfaces to the operating system using the standard device drivers. **Note:** If you have a second cluster of terminals, order two VT1XX-EBs. External cables not included. Use BC22F to connect DZS11-EA, VT1XX-EB to modems, and BC22D to connect asynchronous terminals to VT1XX-EB. RS422 cable connectors are supplied.

### DZ11-EA (Host)

DZ11-EA-compatible interface between the UNIBUS and up to two terminal multiplexers (VT1XX-EB).

### VT1XX-EB (Terminal)

Eight-channel multiplexer.

### DFM

The DFM series of Intelligent Communications Processors (ICP) are freestanding units that utilize statistical time division multiplexing techniques for concentrating four to sixteen RS232-C data channels over a single high-speed communications link. These data channels interface to any RS232-C compatible device such as terminals, printers, personal computers, workstations, and computer ports. The data received by the second ICP is error corrected and distributed to the appropriate users at the end of the network.

#### Features include:

- Switching and Contention, which allows users to create a logical connection between their terminal and any other compatible device connected to either end of the network. Synchronous channel input on up to 50% of the channels at 1200 to 9600 b/s.
- Asynchronous Input speeds of 50 to 9600 b/s with autobaud above 150 b/s.
- Concentrated Link speeds of 1200 to 19,200 b/s.
- 16-bit error detection with automatic retransmit on error for asynchronous channels.
- Speed and flow control conversion.
- EIA dial-up support, otherwise known as tail-end circuit support.
- Easy expansion through the addition of lines or integral modems. Extensive network management and control functions. The DFM integral modems are for use only with dedicated telephone lines.

**Note:** For more information, refer to (Computer Special Systems group) Product Bulletin.

# UNIBUS Communication Options

## Ethnet Options

- DEUNA-AA** The Ethernet communications controller connects a UNIBUS system to an Ethernet local area network. Both DECnet and device driver level software support are available. The DEUNA complies with the Ethernet Specification, transmits and receives at 10 MB/s, and provides full address filtration to off-load the host computer.
- External transceiver cables (BNE3C OR BNE3A type) and the H4000 transceiver or DELNI must be ordered separately.
- DELNI** The DELNI is a table top unit which allows up to 8 Ethernet systems to be connected together in a local area using only Ethernet transceiver cables. The DELNI enables a number of systems to be connected in a small diameter(100 meter ,328 ft) area for a low cost.
- DEREP-AA** Ethernet Repeater used to connect two Ethernet cable segments together for a larger network.
- H4000** The H4000 Digital Ethernet transceiver is a device that provides the functional interface between the Ethernet coaxial cable and an Ethernet station. The H4000 transmits signals onto and receives signals from the cable, and detects any message collisions that may occur. It provides electrical isolation and high impedance to the coaxial cable.
- The transceiver consists of a small printed circuit board contained in a rugged, compact plastic housing. The plastic housing contains a non-intrusive cable tapping assembly that is used for making the actual physical connection to the Ethernet coaxial cable.

## Modems (For Use In U.S.A. Only)

- DF02-AA** Direct connect, full-duplex, asynchronous modem with self-contained power supply operating at speeds of 0-300 bits per second. Allows terminals and processors to communicate over unconditioned, dial-up lines. Compatible with DF03 modem (at  $\leq 300$  baud), Bell System 103J, 212A (at  $\leq 300$  baud) data sets, and all Digital asynchronous data communication controllers that support RS232-C interface standard and dial-up modem control.
- DF02-AC** Consists of a DF02 modem with serial Automatic Call Unit (ACU). ACU allows initiating calls without operator intervention, and uses an asynchronous ASCII input format at switch-selectable data rates of 110 or 300 bits per second. Can store up to 16 digits for dialing/redialing.
- DF03-AA** Direct connect, full-duplex, synchronous/asynchronous modem with self-contained power supply operating at speeds of 0-300 b/s or 1200 b/s. Allows terminals and processors to communicate over unconditioned, dial-up lines. Low-speed operation (0-300 b/s) is asynchronous; high-speed operation (1200 b/s) can be either character-asynchronous or bit-synchronous. Compatible with the DF02 (at  $\leq 300$  baud) modem, Bell System 103J, 212A data sets, and all Digital data communication controllers that support RS232-C interface standard and dial-up modem control.
- DF03-AC** Consists of a DF03 modem with serial Automatic Call Unit (ACU). ACU allows computer to initiate calls without manual intervention, and uses an asynchronous ASCII input format at switch-selectable data rates of 110, 300, or 1200 bits per second. Can store up to 16 digits for dialing/redialing.



# Communication Cables

**Cable Description Chart**

Option	Length	Description	Where used
BC04R-xx	3.7 m (12 ft)	Round, 6-conductor, general purpose module termination cable assembly	20mA I/O devices (DZ11)
BC05F-xx	4.6 m (15 ft) 15.2 m (50 ft) 30.5 m (100 ft)	Round, 4-conductor, Male 8-pin connector	20mA I/O devices (DL11)
BC22D-xx	3.1 m (10 ft) 7.6 m (25 ft) 10.7 m (35 ft) 15.2 m (50 ft) 22.9 m (75 ft) 30.5 m (100 ft) 76.2 m (250 ft)	Null modem, round, 3 shielded twisted pair, RS232-C female connectors	Local connection of asynchronous terminals with RS232-C interface
BC22E-xx	3.1 m (10 ft) 7.6 m (25 ft) 10.7 m (35 ft) 15.2 m (50 ft) 22.9 m (75 ft)	Modem, round, 16-wire fully shielded, RS232-C male and female molded connectors	Connect synchronous and asynchronous modems with RS232-C interfaces, EIA extension cable
BC22F-xx	3.1 m (10 ft) 7.6 m (25 ft) 10.7 m (35 ft) 15.2 m (50 ft) 22.9 m (75 ft)	Full, EIA modem/extension cable, round, 25-wire, fully shielded, RS232-C male and female molded connectors	Connect synchronous and asynchronous modems with RS232-C interfaces, EIA extension cable
BC55D-xx	3.1 m (10 ft) 7.6 m (25 ft) 15.2 m (50 ft)	Integral modem, triaxial cable with CPC connectors	Used to connect DMR, DMP, DMV older options using plastic connectors
BC55S-xx	7.6 m (25 ft) 15.2 m (50 ft) 22.9 m (75 ft) 30.5 m (100 ft) 76.2 m (250 ft) 152.4 m (500 ft) 304.9 m (1000 ft) 1,067 m (3500 ft)	Integral modem, triaxial cable with BNC connectors	Used to connect new style DMR, DMP, DMV options
BC55T-xx	7.6 m (25 ft) 15.2 m (50 ft) 22.9 m (75 ft) 30.4 m (100 ft) 76.2 m (250 ft) 152.4 m (500 ft) 304.8 m (1000 ft) 1,067 m (3500 ft)	Integral modem, twinaxial cable with BNC connectors	Used to connect new style DMR, DMP, DMV options
BC56A-xx	0.6 m (2 ft)	Male to male BC55S to BC55M adapter cable	Used to connect new style DMR, DMP, DMV options to old options using CPC plastic connectors
BC56B-xx	0.6 m (2 ft)	Male to female BC55S to BC55M adapter cable	Used to connect new style DMR, DMP, DMV options to old options using CPC plastic connectors
BC56D-xx	0.6 m (2 ft)	Male to male BC55T to BC55N adapter cable	Used to connect new style DMR, DMP, DMV options to old options using CPC plastic connectors

# Communication Cables

Option	Length	Description	Where used
BC56E-xx	0.6 m (2 ft)	Male to female BC55T to BC55N adapter cable	Used to connect new style DMR, DMP, DMV options to old options using CPC plastic connectors
BNE2A-MA	23.4 m (77.1 ft)	Coaxial cable	Ethernet
BNE2A-MB	70.2 m (231.6 ft)	Coaxial cable	Ethernet
BNE2A-MC	117 m (386.1 ft)	Coaxial cable	Ethernet
BNE3A-xx	5 m (16.4 ft) 10 m (32.8 ft) 20 m (65.6 ft)	Straight entry transceiver cable	Ethernet
BNE3B-xx	5 m (16.4 ft) 10 m (32.8 ft) 20 m (65.6 ft)	Right angle transceiver cable	Ethernet
BNE3C-xx	5 m (16.4 ft) 10 m (32.8 ft) 20 m (65.6 ft)	Straight entry Teflon transceiving drop cable	Ethernet
BNE3D-xx	5 m (16.4 ft) 10 m (32.8 ft) 20 m (65.6 ft)	Right angle entry Teflon transceiver drop cable	Ethernet

## To Order Cables:

A cable model number beginning with **BC** indicates an English length. A cable model number with **BN** indicates a metric length.

To order a cable, select the option number and replace the **-xx** with the correct suffix for feet or meters.

For lengths of up to 99 feet, simply substitute the number of feet.

Example:

BC22D-75 (75-ft BC22D cable)

BNE3A-05 (5-meter Ethernet cable)

For lengths of 100 feet/meters or over, change the **-xx** suffix as follows:

100 feet/M	A0
110 feet/M	A1
120 feet/M	A2
130 feet/M	A3
140 feet/M	A4
200 feet/M	B0
210 feet/M	B1
300 feet/M	C0
400 feet/M	D0
500 feet/M	E0
Up to 2190 feet/M	Z9

Example:

BC22D-B5 (250-ft BC22D cable)

**Note:** The letters G, I, O, Q, and X are not used to identify cable lengths.

# Realtime Options

---

## Q-bus Digital I/O Options

<b>DRV11-LP</b>	<b>System option.</b> General purpose program-controlled parallel line interface unit. Permits program-controlled data transfers at rates up to 40K words per second. <b>Note:</b> <i>External cables not included.</i> BC04Z or BC07D are recommended.
<b>DRV11</b>	<b>Upgrade option.</b> Includes only base option module. Select one of the following cabinet kits:
<b>CK-DRV1B-KA</b>	Cabinet kit for use with BA23 box (MICRO/PDP-11).
<b>CK-DRV1B-KB</b>	Cabinet kit for use with BA11-M box (PDP-11/23-S).
<b>CK-DRV1B-KC</b>	Cabinet kit for use with H349 panel (PDP-11/23-PLUS).
<b>DRV11-BP</b>	<b>System option.</b> General purpose direct memory access (DMA) parallel line interface unit. It permits data transfers at rates up to 250K words per second in single cycle mode and up to 500K words per second in burst mode. <b>Note:</b> <i>External cables not included.</i> BC04Z or BC07D are recommended. DMA capability limited to first 256 KB.
<b>DRV11-B</b>	<b>Upgrade option.</b> Includes only base option module. Select one of the following cabinet kits:
<b>CK-DRV1B-KA</b>	Cabinet kit for use with BA23 box (MICRO/PDP-11).
<b>CK-DRV1B-KB</b>	Cabinet kit for use with BA11-M box (PDP-11/23-S).
<b>CK-DRV1B-KC</b>	Cabinet kit for use with H349 panel (PDP-11/23-PLUS).
<b>DRV11-JP</b>	<b>System option.</b> General purpose program-controlled parallel line interface. Contains 64 bidirectional input/output lines configured as four 16-bit ports. Bit interruptable on up to 16 lines. Interrupt vectors may have fixed or rotating priorities. <b>Note:</b> <i>External cables not included.</i>
<b>DRV11-J</b>	<b>Upgrade option.</b> Includes only base option module. Select one of the following cabinet kits:
<b>CK-DRV1J-KA</b>	Cabinet kit for use with BA23 box (MICRO/PDP-11).
<b>CK-DRV1J-KB</b>	Cabinet kit for use with BA11-M box (PDP-11/23-S).
<b>CK-DRV1J-KC</b>	Cabinet kit for use with H349 panel (PDP-11/23-PLUS).

## UNIBUS Digital I/O Options

<b>DR11-W</b>	General purpose direct memory access (DMA) controller which interfaces user devices to the PDP-11 UNIBUS. In addition, the DR11-W provides a half-duplex interprocessor link between UNIBUS, VAX, and Q-bus systems when connected to another DR11-W (for UNIBUS or VAX) or DRV11-B (for Q-bus). Features include: transfer of up to 64K 16-bit words at up to 500,000 words per second; word or byte transfers; and burst data transfers. <b>Note:</b> BC06R-xx or equivalent cables are required for interconnect, the maximum length being 15.2 m (50 ft). Cabinet kit not required. Required cables are standard.
<b>DRS11/DS11</b>	The DRS11/DSS11 digital input/output devices provide UNIBUS PDP-11 computers with efficient monitoring and control functions useful for a variety of industrial and scientific applications. Specific features include monitoring operator panels, controlling relays and indicator lights, scanning limit switches and unlocking doors. The input module (DSS11) provides 48 optically isolated inputs with one interrupt input. The output module (DRS11) provides 48 buffered outputs with one interrupt. Any mixture of DRS11 and/or DSS11 modules may be mounted in a UNIBUS system provided that the total does not exceed 16 and subject to the normal constraints of mounting space, bus loads and 5 volt power.
<b>DRS11-A</b>	Digital output device (TTL); includes one RC filtered interrupt input, two 3 m (19.6 ft) flat ribbon cables (50 conductors) terminated into 50 pin BERG connectors for connection to field output signals.
<b>DRS11-B</b>	Digital output device with open collector drivers; includes one RC filtered interrupt input, two 3 m (19.6 ft) flat ribbon cables (50 conductors) terminated into 50 pin BERG connectors for connection to field output signals.
<b>DRS11-MP</b>	Optically isolated DC drivers with open collectors; prerequisite is DRS11-B.
<b>DSS11-A</b>	Digital input device (TTL); includes two 3 m (19.6 ft) ribbon cables (50 conductors) terminated into 50 pin BERG connectors for connection to field input signals.
<b>DSS11-B</b>	Digital input device; includes two 3 m (19.6 ft) ribbon cables (50 conductors) terminated into 50 pin BERG connectors for connection to field input signals.
<b>DSS11-M</b>	Contact sense input; prerequisite is DS11-A.

**Voltage Information for DRS11/DSS11**

Option	(Output Voltage) Off State	(Output Voltage) On State	Isolation Voltage	Input Voltage
DRS11-A	TTL	TTL	N/A	N/A
DRS11-B	30Vdc	0.7 Vdc/40 mA	N/A	N/A
DRS11-MP	50Vdc	1 Vdc/75 mA	500Vdc	N/A
DSS11-A	N/A	N/A	500Vdc	4-7 Vdc
DSS11-B	N/A	N/A	500Vdc	24 Vdc
DSS11-MP	N/A	N/A	N/A	24 Vdc

The DRU11-C allows users to interface a UNIBUS based CPU to instruments and other devices that require large amounts of data to be passed to or from them at moderate to high speeds (up to 500 KW/s continuous). This is accomplished by establishing two buffers in main memory. Data transfers go to the first buffer. Once the first buffer is full, transfer automatically shifts to the second buffer as it simultaneously transfers the contents of the first buffer to a disk or processor. When the second buffer is full, transfer switches back to the first buffer. In this way, very large blocks of data can be moved to or from the processor without interruption.

The DRU11-CC version uses TTL drivers and will interface to devices up to 15 m (49.2 ft) from the processor. For longer distances the DRU11-CD incorporates differential drivers and receivers that are capable of transferring data up to 300 m (984 ft) from the processor.

**DRU11-CC** Alternate buffer interface with TTL drivers; 15 m (49.2 ft).

**DRU11-CD** Alternate buffer interface with differential drivers; 300 m (984 ft). DRU11-CC plus signal conditioning module. Cables are not included. The BC05L-xx or BC08R-xx are recommended.

## Q-bus Analog I/O Options

**AAV11-C** 12-bit, 4-channel digital-to-analog converter and CRT control. Provides an output signal that meets the needs of many industrial and laboratory applications.

**ADV11-C** 12-bit, 16 channel analog-to-digital converter with program-controlled sampling rates to 25 kHz and external realtime clock input for A/D trigger. Provides input capability for many industrial and laboratory applications.

**AXV11-C** Combination 16-channel analog input, 2-channel analog output interface board for the Q-bus. Features two analog output channels with ranges identical to the input channels.

**Note:** Analog options are compatible with the system backplane but are **not** installed in a Digital manufacturing facility. They do not include I/O Connection Panel inserts, nor are they qualified for use in a FCC Class A system. They are available as **add-on options** for installation in a system by technically experienced customers. UNIBUS analog options are described in the **Peripherals Handbook**.

## IEEE Interfaces

Digital's family of IEEE bus interface controllers connect a Q-bus or a UNIBUS based system to IEEE-448-1978 test equipment.

The IEU11 and IEQ11 incorporate two independent IEC/IEEE-448 controllers. Each controller is capable of supporting up to 15 instruments, including the controller itself. This gives the user the ability to connect up to 28 instruments to a single module. The IEC11 is a single controller which allows you to connect up to 15 instruments, including the controller itself.

The IEU11, IEQ11, and IEC11 are bit-parallel byte-serial controllers that can perform transfers in either program interrupt or direct memory access (DMA) mode. DMA is standard with the IEU11 and the IEQ11. It is optional with the IEC11. Each independent bus provides system controller, controller-in-charge, talker, and listener capabilities. Termination of data transfers are by E.O.I. or byte count. The IEU11 and IEQ11 also offer termination of data transfers by match characters.

# Realtime Options

---

- IEU11-AB** Dual bit-parallel, byte-serial DMA bus interface controller for UNIBUS IEEE-488-1978 instruments. Includes interface module, test cable, bulkhead/cable assembly for connecting to one of the two IEEE controllers on the module. See the cable chart below.
- IEQ11-AB** Dual bit-parallel, byte-serial DMA bus interface controller for Q-bus IEEE-488-1978 instruments. Includes interface module, test cable, bulkhead/cable assembly for connecting to one IEEE STD 488 controller. See the cable chart below.
- IEC11-AB** Bit-parallel, byte-serial bus controller for UNIBUS IEEE STD-488-1978 devices.
- IEC11-BA** DMA option for the IEC11-AB.
- IEC11-CA** IEC11-AB plus IEC11-BA. See the cable chart below.

## Cable Information for IEEE Interfaces

Model	Standard	Cable to 1st Controller	Cable to 2nd Controller	Cable to User Device
IEU11-AB	IEEE 488	Included	BN11D-02	BN01A-02
IEQ11-AB	IEEE 488	Included	70-20161-01	BN01A-02
IEC11-AB	IEEE 488	Included	N/A	BN01A-02
IEC11-BA	IEEE 488	Included	N/A	BN01A-02
IEC11-CA	IEEE 488	Included	N/A	BN01A-02

## Realtime Clocks

- KW11-P** UNIBUS programmable realtime clock. Program-selectable interrupts of 100 kHz, 10 kHz, line frequency or external signal, counted down by 16-bit counters with automatic reload.
- KW11-C** Q-bus 16-bit programmable realtime clock. Four programmable modes and five crystal-controlled frequencies are user-selectable. Refer to the **Microcomputer Interfaces Handbook**.

## I/O Cables

**BC07D-xx** 2 X 20-conductor, flat ribbon cable assembly has a 40-pin female H856 connector. The one open end allows the user to configure this cable to specific system requirements, providing compatibility with customer-supplied equipment and instruments. May be used with DRV11. The following standard lengths are available:

<b>BC07D-10</b>	3.0 m (10 ft)
<b>BC07D-15</b>	4.6 m (15 ft)
<b>BC07D-25</b>	7.6 m (25 ft)

**BC06R-xx** 40-conductor, flat, shielded cable with connectors at both ends. May be used with the DR11-W. The following standard lengths are available:

<b>BC06R-06</b>	6 ft(1.8 m)
<b>BC06R-10</b>	10 ft(3 m)
<b>BC06R-25</b>	25 ft(7.6 m)
<b>BC06R-50</b>	50 ft(15.2 m)

**BC20M-50** RS232 I/O cable with 10-pin AMP connectors at both ends. For use in high-speed communication between two DLV11-Js. Available in 50 ft (15.2 m) length.

**BC21B-05** Round, 6-conductor cable assembly has a male EIA RS232 connector with built-in strain relief at one end and a 10-pin keyed socket at the other end. This 3-twisted wire pairs, shield cable is for use with the DLV11-J. Available in 5 ft (1.5 m) length.

**BC04Z-xx** 40-conductor, flat, multipurpose cable has one pre-assembled terminated end. The one open end allows the user to configure this cable to specific system requirements, providing compatibility with customer-supplied equipment and instruments. Also features one H855 connector. May be used with DRV11. The following standard lengths are available.

<b>BC04Z-01</b>	1 ft (0.3 m).
<b>BC04Z-06</b>	6 ft (1.8 m).
<b>BC04Z-10</b>	10 ft (3.0 m).
<b>BC04Z-15</b>	15 ft (4.6 m).
<b>BC04Z-25</b>	25 ft (7.6 m).
<b>BC04Z-50</b>	50 ft (15.2 m).

**BC07D-xx** 20-conductor flat ribbon cable assembly has a 40-pin female H856 connector. The one open end allows the user to configure this cable to specific system requirements, providing compatibility with customer-supplied equipment and instruments. May be used with DRV11. The following standard lengths are available:

<b>BC07D-10</b>	10 ft (3.0 m).
<b>BC07D-15</b>	15 ft (4.6 m).
<b>BC07D-25</b>	25 ft (7.6 m).

# Environmental Information and Products

---

Proper site planning and preparation can simplify the system installation process and can produce efficient, reliable system operation. Although each system site is different, the following points should be evaluated in order to ensure maximum system efficiency:

- Space for system components with an area for operation, maintenance, and ventilation. (Digital recommends a one m (39 in) front, rear, and side service area for cabinets.)
- Access to adequate system power (voltage, current, and frequency) that is free from power line disturbances.
- Installation of a dedicated power distribution panel for the computer system.
- Proper fire and safety precautions (including emergency shutdown capability).
- Adequate air conditioning and humidifying equipment.
- Construction requirements (raised floors, floor loading and grounding, cable location, etc.).
- Operational requirements that determine the specific location of freestanding system peripherals.
- Location of peripheral devices so that the length of the connecting cable will not exceed maximum limits.
- Availability of additional space and power service for future system expansion.

The computer area environment (temperature and humidity) has a substantial effect on the overall reliability of a system and should be individually evaluated by a Digital Field Service representative. For optimal system performance, Digital recommends the following environment:

- Temperature: 21° plus or minus 3°C (70° plus or minus 5°F)
- Temperature rate of change: 3°C/hr(5.5°F/hr)
- Relative humidity: 50% plus or minus 10% (no condensation)
- Humidity rate of change: 6%/hr

Several environmental products designed to enhance system reliability and performance are described in this section. Please remember that all PDP-11 environments should be fully evaluated by a Digital field service representative to ensure best system performance.

# Power Distribution System

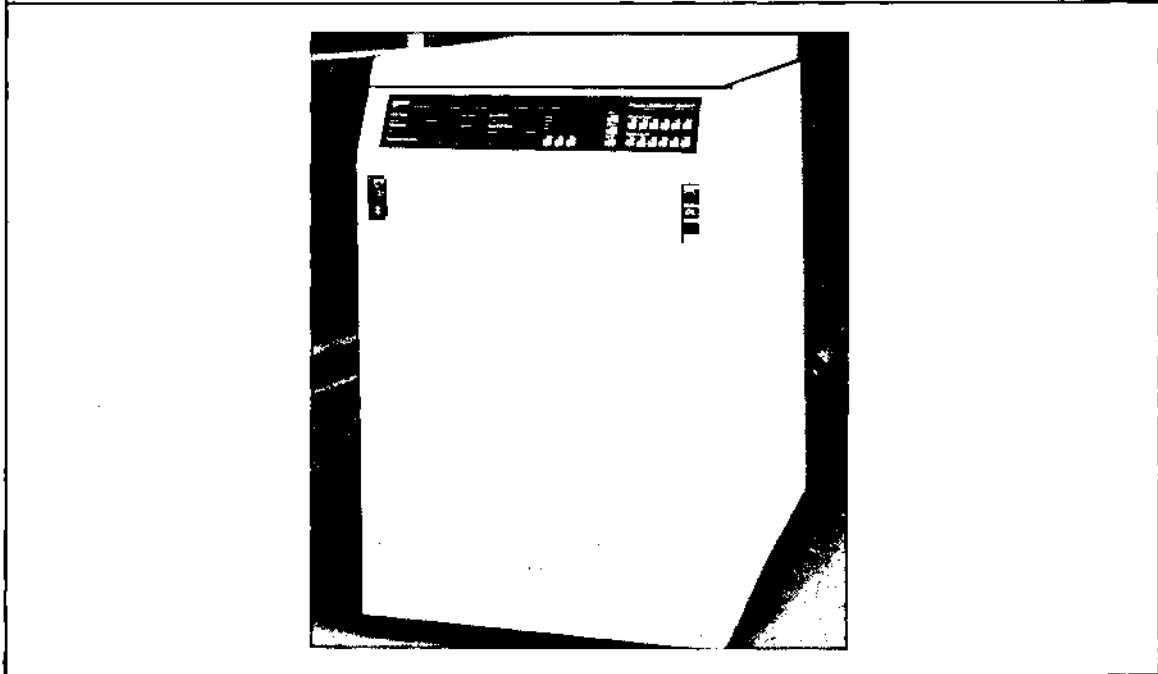

Options

The Power Distribution System (PDS) is designed for medium- to large-sized (15 - 100 KVA) Digital computer systems and is recommended for use with configurations of four or more cabinets. It contains all the AC power components necessary to provide AC power to the CPU cabinet, expansion cabinets, and peripheral devices, and to connect the entire computer system to the building power source. It is designed not only to distribute power, but also to monitor power to the computer system.

Whether purchasing a new Digital computer system, moving a present system, adding to or reconfiguring a present system, the addition of the PDS can simplify installation and provide greater flexibility in layout. The PDS unit is about the size of a typical freestanding disk drive. Everything the user needs to install the system is furnished with the PDS - power junction box, input cable and attachment plug, input main circuit breaker, main transformer, output power cables, output panelboards and circuit breakers, common ground reference, and safety ground connector.

The PDS provides electrical and safety requirements within the restrictions of the National Electrical Code, and is U.L. listed. For further information concerning this product, consult your local Digital sales representative or Digital's Installed Base Group (IBG).



# Constant Voltage Conditioner

---

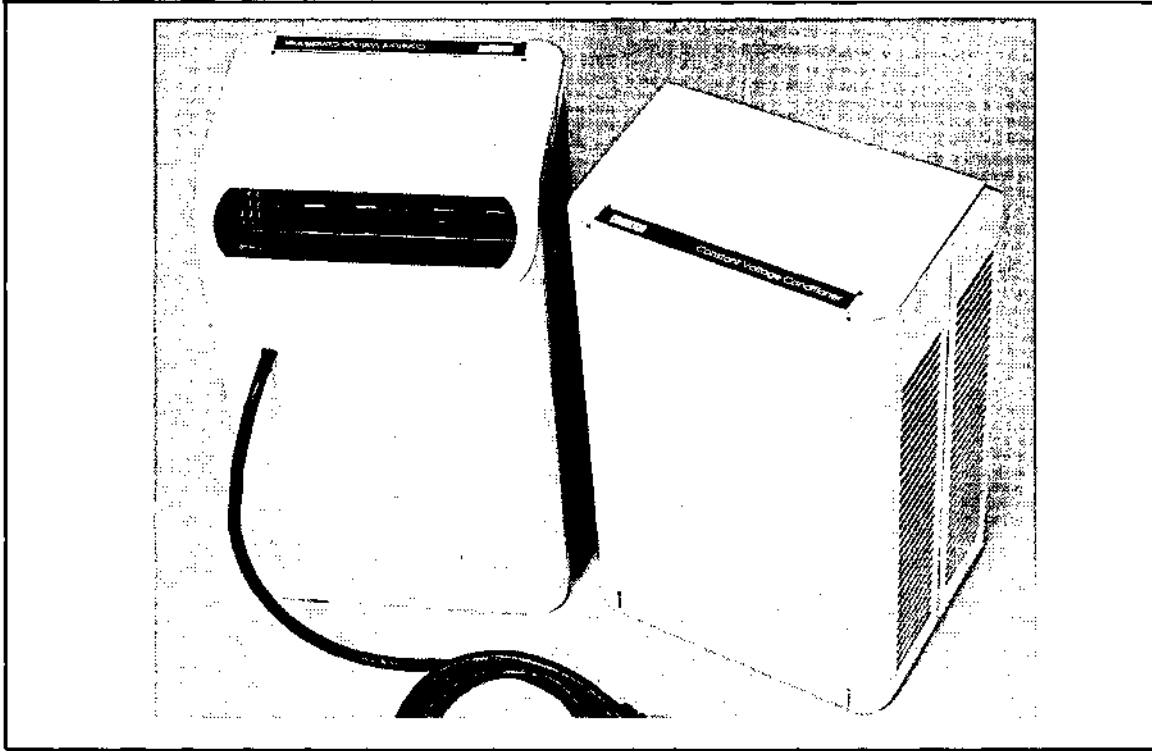

The Constant Voltage Conditioner (CVC) is a completely portable, self-contained, integrated power conditioning system. It is designed specifically for small Digital computer systems, such as the PDP-11/23-PLUS, the PDP-11/24, the MICRO PDP-11, the Professional 300, and Digital word processors and video terminals.

The CVC was developed to correct input voltage fluctuations, as well as 'brownout' conditions often encountered during peak power usage situations. Protection from electrical noise and impulses and 'spikes' is also provided by the CVC.

Further information on this product can be obtained from your local Digital sales office or by contacting Digital's Installed Base Group (IBG).

## **Performance Characteristics:**

- Single-point grounding
- Isolation
- Voltage regulation
- High-quality connectors and components

# Transient Voltage Surge Suppressors

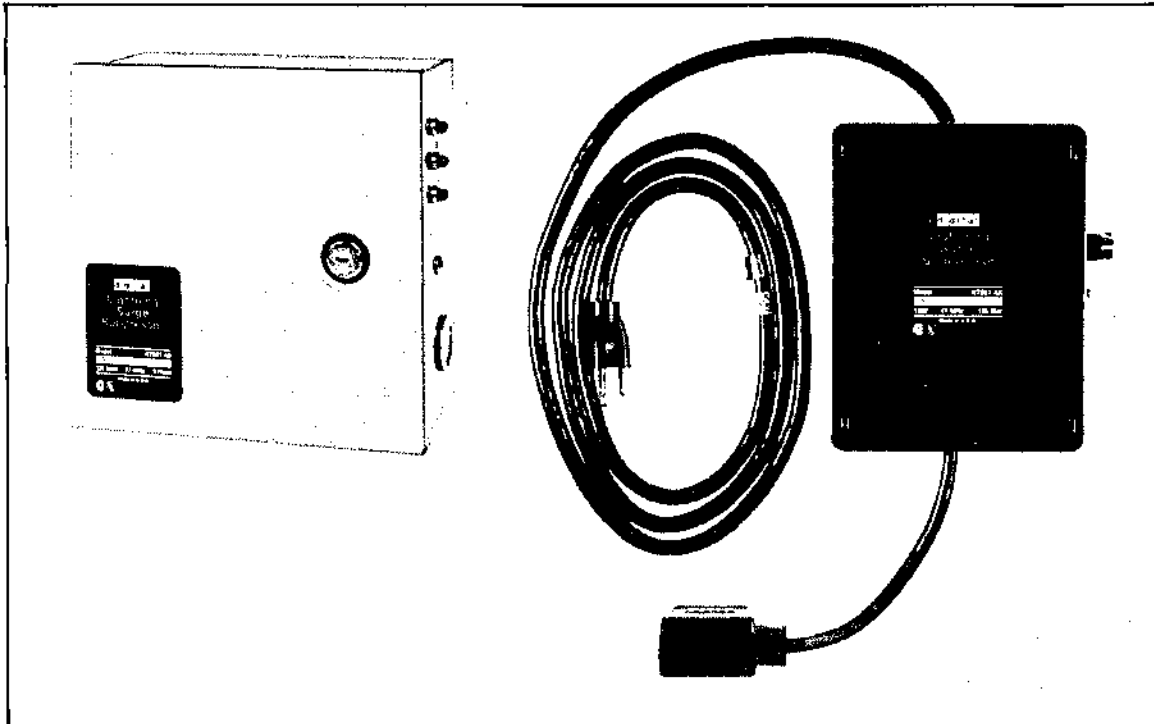

High-energy surges caused by electrical storms and by man-made disturbances can damage your computer system. These energy surges can enter your system through the AC power lines or through the data communication lines. Digital now has a family of products designed specifically to solve these problems.

The H7007-A series of Transient Voltage Surge Suppressors for AC power provides high-energy, fast-acting, power-line transient protection regardless of the cause. The H7007-B and C series of suppressors are designed to protect single and multiple data lines in both EIA and 20mA configurations. For receiver and transmitter protection, a transient Voltage Surge Suppressor should be installed at both ends of the data line.

## Features and Benefits:

- High current protection
- Fast response time
- No hold over current
- Fast, simple installation
- Instant recovery
- Multistage hybrid circuit design
- Failure indicator lamp (H7007-A)
- Four conductors protected plus cable (H7007-B)

# Configuring Information

**Q-bus Processor Options & Memories Configuring Chart**

Option	Mounting Code	DC Amps Drawn @ +5V/+12V	Watts	Bus Loads Drawn (AC/DC)
FPF11	Quad Slot in CPU Backplane	7.5/0	37.5	0
MSV11-PK	Quad Slot	3.45/0	17.3	2/1
MSV11-PL	Quad Slot	3.6/0	18	2/1
MCV11-DC	Double Slot	1.2/0	6	2/1

**PDP-11/24 Processor Options & Memories**

Option	Mounting Code	DC Amps Drawn @ +5V	Bus Loads Drawn
FPF11	Quad slot in CPU backplane	7.5	0
MS11-PB	Hex Slot	4.8	1
KT24	Hex Slot adjacent to CPU	4.5	1

**PDP-11/44 Processor Options & Memories**

Option	Mounting Code	DC Amps Drawn @ +5V	Bus Loads Drawn
FP11-F	Dedicated (Hex) Slot	7.3	0
KE44-A	Dedicated (Hex plus Quad) Slots	9.6	0
MS11-PB	Dedicated (Hex) Slot	4.8	0

**Note:** Each MS11-LD or MS11-PB consumes one bus load in the PDP-11/24. Each MS11-LD or MS11-PB consumes no bus loads in the PDP-11/44.

# Configuring Information

**Q-bus Communication Options Configuring Chart**

Option	Mounting Code	DC Amps Drawn @ +5V/+12V	Watts	Bus Loads AC/DC	I/O Panel Insert Size
DLVE1-DP	1 Double Slot	1.0/.15	6.8	1.6/1	Size A
DLVJ1-LP	1 Double Slot	1.0/.25	8	1/1	Size B
DMV11-BP	1 Quad Slot	3.4/0.38	21.6	2/1	Size A
DMV11-CP	1 Double Slot	3.35/.26	19.9	2/1	Size B
DMV11-AP, FP	1 Quad Slot	3.4/0.38	21.6	2/1	Size B
DPV11-AP	1 Double Slot	1.2/0.3	9.6	1/1	Size A
DUV11-AP	1 Quad Slot	.86/.32	9.8	1/1	Size A
DZV11-DP	1 Quad Slot	1.2/0.39	10.4	3.9/1	Size B
KMV11-AA	1 Quad Slot	4.2/0.2	23.4	1/1	Size A

# Configuring Information

**UNIBUS Communication Options Configuring Chart**

Option Number	Mounting Code	DC Amps Drawn @ +5V/ +15V/-15V	Bus Loads Drawn	Panel Units
DEUNA	2 Hex Slots	15.0	2	2
DH11-AP	2 SUs	10.8/0.40/0.65	3	8
DH11-DP	2 SUs	8.6/0.10/0.34	2	8
DL11-AP	1 Quad Slot	1.8/0.05/0.15	1	1
DL11-HP,DP	1 Quad Slot	2.0/0.05/0.15	1	1
DMP11-AP,-EP	2 Hex Slots	12.0/0.08/0.19	1	1
DMP11-BP	2 Hex Slots	12.0/0.10/0.20	1	1
DMP11-CP,-FP	2 Hex Slots	12.0/0.10/0.20	1	2
DMR11-AP,-BP,-EP	2 Hex Slots	12.0/0.08/0.19	1	1
DMR11-CP,-FP	2 Hex Slots	12.0/0.11/0.20	1	2
DUP11-AP	1 Hex Slot	3.6/0.08/0.08	1	1
DZ11-DP	1 Hex Slot	2.5/0.13/0.15	1	4
DZ11-HP	1 Hex Slot	3.0/0.13/0.30	1	4
DECmux				
DZS11-EA	1 Hex Slot	3.35/0.13/1.5	1	2
VT1XX-EB	VT100-AA,AB	Supplied by VT100	N/A	N/A
KMS11-BD,-BE	2 SUs	12.5/1.5/0.5	3	8
PCL11-B	2 SUs	14/N/A/0.5	1.5	2

# Configuring Information

## UNIBUS Realtime Options Configuring Chart

Option Number	Mounting Code	DC Amps Drawn @ +5V / +15V / -15V	Bus Loads Drawn	Panel Inserts
DR11-W	Hex Slot	3.7/0.0/0.0	1	1
DRS11-A,-B	1 Quad Slot	2.5/0.0/0.0	1	2
DRS11-MP	1 Quad Slot	1.5/0.0/0.0	N/A	2
DSS11-A,-B	1 Quad Slot	1.6/0.0/0.0	1	2
DSS11-MP	1 Quad Slot	N/A	N/A	2
DRU11-CC	1 Quad Slot	1.5/0.0/0.0	1	2
DRU11-CD	1 Hex Slot	2.2/0.0/0.0	1	2
IEU11-AB	1 Hex Slot	3.5/0.0/0.0	1	1
IEC11-AB	1 Hex Slot	2.5/0.0/0.0	1	1
IEC11-BA	1 Hex Slot	2.5/0.0/0.0	1	1
IEC11-CA	2 Hex Slots	5.0/0.0/0.0	2	1
KW11-P	1 Quad Slot	1.0/0.0/0.0	1	N/A
KWV11-C	1 Dual Slot	2.2/0.01	1/1	1

**Note:** The IEC11-BA is the DMA option for IEC11-AB. Mount the DRS11-MP next to the DRS11-B. Mount the DSS11-MP next to the DSS11-A.

## Q-bus Realtime Options Configuring Chart

Option	Mounting Code	DC Amps Drawn @ +5V / +12V	Watts	Bus Loads (AC/DC)	I/O Panel Insert Size
DRV11-BP	1 Quad Slot	1.9/0.0	9.5	3.3/1	2 Size A
DRV11-JP	1 Dual Slot	1.8/0.0	9	2/1	2 Size A
DRV11-LP	1 Dual Slot	.90/0.0	4.5	2.8/1	2 Size A
AAV11-C	1 Dual Slot	2.5/0.0	12.5	.9/1	
AXV11-C	1 Dual Slot	2.0/0.0	10.0	1.3/1	
ADV11-C	1 Dual Slot	2.0/0.0	10.0	1.3/1	
IEQ11-AB	1 Quad Slot	3.5/0.0	17.5	2/1	
KWV11-C	1 Dual Slot	2.2/0.01	11	1/1	

1. The first part of the document discusses the importance of maintaining accurate records of all transactions and activities. It emphasizes that this is crucial for ensuring transparency and accountability in the organization's operations.

2. The second part outlines the various methods and tools used to collect and analyze data. This includes the use of surveys, interviews, and focus groups to gather insights from stakeholders and employees.

3. The third part details the process of identifying and addressing key challenges and opportunities. It highlights the need for a proactive approach to problem-solving and the importance of involving all relevant parties in the decision-making process.

4. The final part of the document provides a summary of the findings and recommendations. It stresses the need for ongoing monitoring and evaluation to ensure that the organization remains agile and responsive to changing circumstances.

# 3 Components

---

The PDP-11 family of microcomputers and minicomputers exemplifies the Digital philosophy of compatibility among products to serve customers more efficiently. Growth and migration is simplified by the constant design of Digital's computers which reflect years of experience in computer technology.

The Q-bus family compatibility and ease of migration is augmented by the fact that the entire Q-bus family is available as **chips, boards, boxes, base and packaged systems**. Customers can pick the level of integration that best meets their needs.

This choice in integration levels, combined with the wide range of performance and functionality within the product family, clearly offer a customer more flexibility and higher performance than many minicomputer and microprocessor offerings.

This section includes the products available to customers who wish to perform their own integration of components. Included are chip and board level processors as well as memories, processor options microprocessor development tools (see also Section 2 — **Options** for additional Q-bus option descriptions).

**Note:**The customer is responsible for the interconnection of products to other parts of the system.

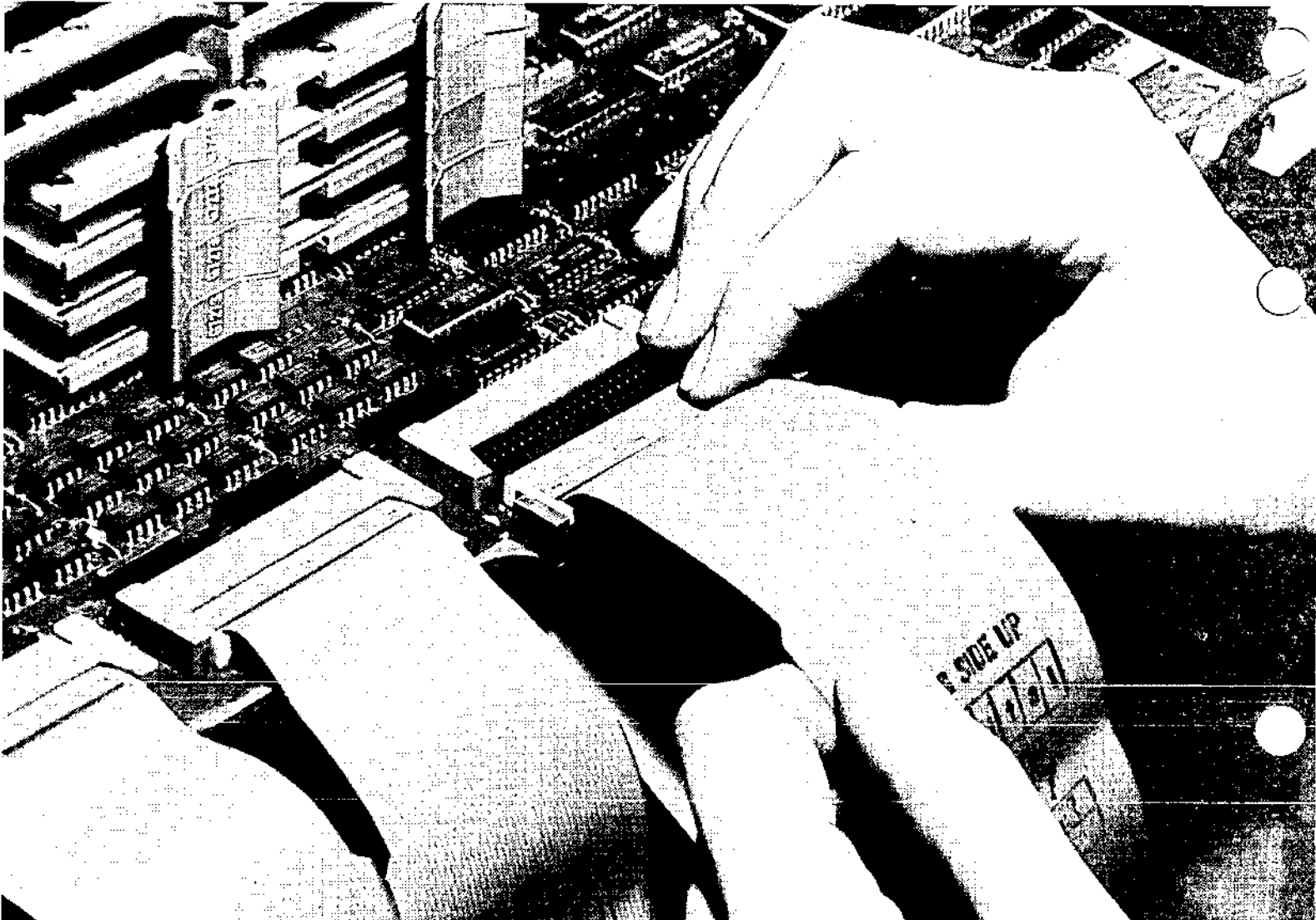



### Chip-Level Microprocessor Selection Chart

Selection Criteria	J-11 (DCJ11-AA)	T-11 (DCT11-AA)
Instruction Set	Base PDP-11, EIS	Base PDP-11
Memory Management	Standard (4 MB)	No (64 KB)
Floating Point	Standard	No
Software Support	MicroPower/Pascal RT-11, RSTS/E RSX-11M/M-PLUS	MicroPower/Pascal RT-11
Technology	CMOS	NMOS
Data Bus Width	16-Bit	8 or 16-Bit
Relative Performance Integer	3.0-5.0	1.0

### Board-Level Microcomputer Selection Chart

Selection Criteria	FALCON (KXT11-AA)	FALCON-PLUS (KXT11-AB)	I/O Processor (KXT11-CA)	LSI-11/23 (KDF11-AA)	LSI-11/23-PLUS (KDF11-BA)	LSI-11/73 (KDJ11-AA)
Board Form Factor	Q-bus Dual	Q-bus Dual	Q-bus Quad	Q-bus Dual	Q-bus Quad	Q-bus Dual
Relative Performance	1.0	1.0	1.5	2.0	2.5	7.0
Floating Point	No	No	No	Optional	Optional	Standard
Memory Management	No	No	No	Yes	Yes	Yes
Additional On-Board Functions	4 KB to 8 KB RAM Up to 32 KB ROM 2 Asynch SLUs 24 Parallel Lines Realtime Clock Q-bus Expansion Capability	16 KB to 32 KB RAM Up to 32 KB RAM or ROM 2 Asynch SLUs 24 Parallel Lines Q-bus Expansion Capability	32 KB RAM to 32 KB ROM ROM 3 SLUs 20 Parallel Lines Realtime Clock 3 Programmable Timers	Q-bus Expansion Capability	2 Asynch SLUs Boot/Clock Q-bus Expansion Capability	Q-bus Expansion Capability
Address Range	Up to 64 KB	Up to 64 KB	Up to 64 KB	Up to 4 MB	Up to 4 MB	4 MB
Software	MicroPower/ Pascal or MACSYS Debug MACRO-11 RT-11	MicroPower/ Pascal or MACSYS Debug MACRO-11 RT-11	MicroPower/ Pascal	RSX-11M RSX-11M-PLUS RT-11 MicroPower/ Pascal MACSYS Debug MACRO-11	RSX-11M-PLUS RT-11 MicroPower/ Pascal MACRO-11 RSX-11S	RSX-11M RSX-11M-PLUS RT-11 MicroPower/ Pascal MACRO-11 MACSYS Debug

# Microprocessor Chips

---

## Microprocessor Chips

Digital's microprocessors provide the flexibility of chip-level design and access to the enormous software base of Digital operating systems, languages, and third-party application software. Competitively priced software licenses to use the full range of operating systems are available with the microprocessors. The PDP-11 system architecture on a chip brings the full minicomputer potential to microprocessor-based products.

<b>DCT11-AA</b>	The T-11 is a single chip microprocessor, in a 40-pin dual-in-line that features a Q-bus compatible instruction set, supports industry standard peripheral chips and can operate at a maximum clock rate of 7.5 megahertz. This powerful microprocessor fully supports both static and dynamic memories, incorporates DMA support as well as an internal and external interrupt structure, and uses a time multiplexed address/data bus and a time multiplexed address/interrupt bus. Through the use of a programmable mode register loaded during power up, the MICRO/T-11 can be adapted to a wide variety of applications. Ceramic package.
<b>DCT11-AB</b>	A 5 megahertz version of the DCT11-AA with all the same functionality; ceramic package.
<b>DCT11-1A</b>	A 7.5 megahertz version of the DCT11-AA with all the same functionality; industrial temperature range -40C to +5C; ceramic package.
<b>DCT11-PA</b>	A 7.5 megahertz version of the DCT11-AA with all the same functionality; plastic package.
<b>DCT11-PB</b>	A 5.0 megahertz version of the DCT11-AA with all the same functionality; plastic package.
<b>DCT11-PC</b>	A 10.0 megahertz version of the DCT11-AA with all the same functionality; plastic package.
<b>DCT11-SK</b>	T-11 Starter kit. The kit includes: one T-11 sample; one DLART sample; T-11 data sheet; DLART data sheet; T-11 user's guide; MDE product overview; 8-bit application note; MDE user's guide; and MicroPower/Pascal introductory manual.
<b>DCJ11-AA</b>	J-11 is a CMOS microprocessor in a 60-pin package that includes 16-bit I/O, a 32-bit internal data path, and addressing capability of up to 4 MB of memory with on-chip memory management. The J-11 implements the full PDP-11 instruction set, including EIS and Floating Point extensions, supports 4 levels of hardware interrupt, and also supports multiprocessing, coprocessing, cache control and fault diagnosis. RT-11, MicroPower/Pascal, RSX-11M, RSX-11M-PLUS and RSTS/E are all available.

## Software

<b>QJB36-DZ</b>	PDP-11 Operating System General License. Valid for DCT11 only. <b>Note:</b> Although the QJB36-DZ license for the T-11 allows use of any PDP-11 Operating System, the T-11 hardware can only be used with RT-11 and RSX.
<b>QJB43-DZ</b>	PDP-11 Operating System General License. Valid for DCJ11 only.

## Microprocessor Support Chips

Digital's microprocessors can be easily interfaced to low-cost commodity peripheral chips. For maximum compatibility with existing software, there is a Digital-compatible serial interface chip — the DLART.

<b>DC319-AA</b>	The DLART is a DL-compatible, asynchronous receiver/transmitter designed for data communications with Digital's microprocessors. The DLART is used as a peripheral device and is programmed by the CPU to operate either in 8-bit or 16-bit mode with asynchronous baud rates varying from 300 b/s to 38.4 KB/s. It has an internal baud rate control that reduces support logic and provides four real-time interrupt outputs to support dynamic memory refresh for realtime system applications such as the FALCON and FALCON-PLUS (SBC-11/21) where a T-11 is used to communicate with DLARTs. It also features one stop bit, 40-pin DIP package, single +5V supply and single TTL clock.
<b>DCK11-AA</b>	Program Control Bus interface chip kit. Consists of the following 6 chips: 1 DC003 interrupt chip, 1 DC004 protocol chip, 4 DC005 transeiver/address decoder/vector select chips.
<b>DCK11-AB</b>	DMA bus interface chip kit. Consists of the following nine chips: one DC003 interrupt chip, one DC004 protocol chip, and four DC005 transeiver/address decoder/vector select chips, two word count/bus address chips, and one DC010 DMA control chip.

## Single Board Processors

Most Q-bus processors are available on a compact, double height 13.3 cm x 22.8 cm (5.25 in x 8.97 in) board. Their 16-bit architecture allows easier programming, greater I/O throughput, and more flexibility than 8-bit microcomputers.

- KDF11-AA** PDP-11/23 with Memory Management Unit (MMU). This 16-bit central processor unit features four MB addressing, four-level vectored interrupts for fast response without device polling, and 87 standard instructions including EIS.
- The MMU provides address relocation to extend the physical address range to four MB. The MMU can divide large segments of memory into smaller, more efficient segments. It also provides users with protection features, such as the ability to control and restrict access to a memory segment.
- In addition, the MMU allows the processor to operate in either a kernel or user mode. In kernel mode, the operating system and programs have complete control and execute all instructions. In user mode, programs are prohibited from performing the instructions that could modify the kernel program, halt the computer, or access memory space reserved to the kernel or other users. The KDF11-AA is a dual-height module.
- KDF11-AC** PDP-11/23 single-board (without MMU), 16-bit central processing unit features 64 KB addressing, four-level vectored interrupts for fast response without device polling, 87 standard PDP-11 instructions including EIS and 46 optional floating point instructions. It is a dual-height module.
- KDF11-BA** Upgrade option. PDP-11/23-PLUS CPU board includes all features of the KDF11-AA plus two serial lines, diagnostics, bootstrap ROM, and program-controlled line clock. The KDF11-BA is a quad-height module. For system installation, select one of the following cabinet kits:
- CK-KDF1B-KA** Cabinet kit. For use with BA23 box (includes selectable baud switch).
  - CK-KDF1B-KB** Cabinet kit. For use with BA11-M box (includes selectable baud switch).
  - CK-KDF1B-KC** Cabinet kit. For use with H349 panel (includes selectable baud switch).
  - CK-KDF2B-KB** Cabinet kit. For use with BA11-M box (does not include selectable baud switch).
- KDF11-BE** Upgrade option. KDF11-BA with Boot ROM for MICRO/PDP-11 (Note that both KDF11-B options can use the same cabinet kits).
- KDJ11-AA** LSI-11/73 high performance PDP-11 processor with 8 KB cache memory, floating point, memory management, and system registers.
- Cache memory - maintains a copy of selected portions of main memory for faster access of instructions and data.
- Floating Point Unit - implements 46 microcode instructions that perform arithmetic, logical, and conversion operations.
- Memory Management Unit - allows for memory addressing up to 4 MB with 22-bit addressing. In addition, the Memory Management Unit allows the processor to operate in either kernel, supervisory, and user (k/yes/u) processor modes.
- Kernel Mode - the most most privileged of the three modes. It allows execution of any instruction or operating system, and programs have complete control and execute of all instructions.
- Supervisory Mode - the next most privileged mode. It may be used to provide for the mapping and execution of programs sharable by users but still requiring protection from them.
- User Mode - the least privileged mode. The programs are prohibited from the instruction that could modify the kernel program, or access memory space reserved to the kernel or supervisory users.
- The system registers are the following, which are briefly described:
- Cache Control - controls operation of cache.
  - Hit/Miss - indicates whether the six most recent CPU memory references resulted in cache hits or cache misses.
  - Program Interrupt Request (PIRQ) - allows generation of software interrupts.
  - CPU Error - identifies the source of failure.
  - Memory System Error - identifies cache or memory parity errors.
  - Line Time Clock - allows software control of the line time clock.
  - Maintenance - allows software to determine which of the module jumpers are installed and which are not installed.
- Compatible with Q-bus 18/22-bit addressing, 4 jumper selectable power-up option, on-board diagnostics with 4 microdiagnostic LEDs. The KDJ11-AA is a dual height module.

# Single Board Processors

---

## Single Board Computers

<b>KXT11-AA</b>	SBC-11/21 FALCON single-board, 16-bit central processor unit features 4 KB of static RAM; 64 KB direct addressing capability; Q-bus interface; PDP-11 base-level instruction set; 50, 60, or 800 Hz realtime clock; 24-line parallel I/O; two asynchronous serial I/O ports; four 28-pin memory sockets for up to 4 KB of additional RAM and 16 KB of ROM, or an extra 32 KB of ROM.
<b>KXT11-AB</b>	SBC-11/21 Falcon-PLUS single-board, 16-bit central processor features 16 KB of static RAM, 64 KB of direct addressing capability; Q-bus interface; PDP-11 base-level instruction set; 50, 60, or 800 Hz realtime clock; 24-line parallel I/O; two asynchronous serial I/O ports; four 28-pin memory sockets for up to 16 KB of additional RAM and 16 KB of ROM, or an extra 32 KB of RAM or 32 KB of ROM.
<b>KXT11-CA</b>	<p>The KXT11-CA single-board computer has two modes of operations. It can be used as a single-board computer or as a peripheral processor.</p> <p>The KXT11-CA single-board, 16-bit central processor unit (T-11) features Q-bus compatability; PDP-11 base-level instruction set; 32 KB of static RAM; two 28-pin sockets for user ROM or static RAM; 20-line parallel I/O; two channel DMA controllers; three programmable interval timers; system line time clock, on-board diagnostic with LED indicators. Has three serial line units: one asynchronous serial line with programmable baud rate from 300 to 38.4 Kbaud, one programmable synchronous/asynchronous serial, and one programmable synchronous/asynchronous modem control.</p> <p>KXT11-CA, single-board computer mode of operation for stand-alone dedicated realtime I/O application.</p> <p>As a peripheral processor up to 14 KXT11-CA may be configured on a single Q-bus with a host processor such as KDJ11 or KDF11. The KXT11-CA is quad height module.</p>

## Software

<b>QJB46-DZ</b>	PDP-11 Operating Systems General License. Valid for KD11 and KDF11 CPU boards only.
<b>QJV51-DZ</b>	KXT11-C tool kit for RT-11.
<b>QJV52-DZ</b>	KXT11-C tool kit for RSX.
<b>KXT11-C</b>	<p>Tool kit that includes the following components:</p> <p>A utility capable of loading binary files into the KXT11 in the system CPU running RT or RSX. Once the program is loaded, the utility allows the programmer to execute the program; aids in debugging phase.</p> <p>An RT or RSX driver for sending and receiving messages from the KXT11 applications.</p> <p>A manual describing how to use the KXT11 from the given operating system.</p>

# Single Board Processors

---

## Processor Options

The Q-bus processors offer single- and double-precision floating point options, the Commercial Instruction Set, and Extended and Floating point Instruction Sets (EIS/FIS).

<b>KEF11-AA</b>	Single- and double-precision floating point option for use with the KDF11-AA. Performs hardware operations on 32-bit and 64-bit floating point numbers. Provides up to 17 digits of precision, as well as integer to floating point conversions. Mounts on the CPU board. 40 pin DIP IC. On KDF11-A, KTF11 is required.
<b>KEF11-BB</b>	Commercial Instruction Set (CIS). Implements a set of 17 commercial instructions on a variety of data types, including character strings, packed decimal, and numeric formats. Mounts on the CPU board.
<b>PPF11</b>	Single- and double-precision floating point option for use with the KDF11-A and KDF11-B boards. The microcode to implement this option resides on one quad module mounted adjacent to the CPU. Performs hardware operations on 32-bit and 64-bit floating point numbers. Provides up to 17 digits of precision, as well as integer to floating point conversions. Executes instructions approximately six times faster than the KEF11-AA.
<b>KTF11</b>	Memory Management Chip for use with the KDF11-AC. It features 4 MB addressing range (22-bit), memory segmentation and built in memory protection. 40 pin DIP IC.
<b>KXT11-A2</b>	This two-chip EPROM set provides a number of special utilities to use while developing, debugging and downline loading software to the KXT11-AA using MicroPower/Pascal.

# Memories and Multifunction Options

---

Digital offers a wide range of microcomputer products including RAM, ROM, PROM and multifunction boards.

## RAM Memories

**MCV11** modules provide CMOS static Random Access Memory with on-board battery backup.

**MCV11-DA** 8 KB with minimum data retention time of 2,647 hours (110 days). It is a dual height module.

**MCV11-DC** 32 KB with minimum data retention of 1,180 hours (50 days). It is a dual height module.

**MSV11** memory modules are complete dynamic MOS memory subsystems.

**MSV11-DD** 64 KB quad height module, 16K RAMs (18-bit addressing).

**MSV11-LF** 128 KB dual height module, 64K RAMs.

**MSV11-LK** 256 KB dual height module, 64K RAMs.

**MSV11-PL** 512 KB with parity, quad height module, 64K RAMs.

**MSV11-PK** 256 KB with parity, quad height module, 64K RAMs.

## ROM Memories

**MRV11** PROM/ROM module with 16 sockets that accept customer supplied, erasable UVPROM, fusible link PROM or masked ROM devices. It also accepts several densities of ROM chips. The MRV11 can operate in window mapping address mode, and also provides bootstrapping capability.

**MRV11-C** Accomodates 24-pin devices up to and including 4K x 8 chips for a total capacity of 64 KB (18-bit addressing).

**MRV11-D** Accomodates 24 and 28-pin devices including 8K x 8 static RAMs, and 32K x 8 chips for a maximum of 512 KB of memory.

## Multifunction Modules

**MXV11** Multifunction module featuring dynamic MOS RAM with on-board refresh, user-configuration with PROM or system device bootstrap ROM option, acceptance of two 5V, 24-pin UVPROM or fusible link PROM chips, two serial lines meeting RS-432 standard (backward compatible with RS-232C), baud rates up to 38.4K, and 50/60 Hz crystal clock.

**MXV11-AA** 8 KB RAM

**MXV11-AC** 32 KB RAM

**MXV11-A2** 256 word bootstrap/diagnostic ROM set for use with the MXV11-AA, MXV11-AC, and MRV11-C. Supports 18-bit addressing and provides bootstrap support for the TU58, RL01, RL02, and RX02.

**MXV11-BF** High density multifunction module includes 128 KB RAM, two 28-pin user ROM sockets, two independently configurable asynchronous serial lines compatible with RS232-C and RS423, and a realtime clock configurable at 50, 60, or 800 Hz. Supports 22-bit addressing.

**MXV11-B2** 8K word bootstrap/diagnostic ROM set for use with the MXV11-BF or MRV11-D. Supports 22-bit addressing and provides bootstrap support for TU58, RL01, RL02, and RX02. Also supports RD/RX50 and DECnet.

## IEEE Option

**IBV11** instrumentation bus interface. Connects the Q-bus to the 16-line, IEEE-488 bus.

# Enclosures, Cables & Backplanes

## System Enclosures

- BA11-MA(MB)** The BA11-MA (MB) master box contains an 18 address bit backplane; the H9270. The H9270 has the Q-bus on slots A/B and C/D and can accept up to eight double-height or four quad-height modules. Dimensions are 8.8 x 48.2 x 34.2 cm (3.5 x 19 x 13.5 in). The power supply (H780) comes with a master console and provides 18 amps @+5V and 3.5 amps @+12V.
- BA11-SA(SB)** The BA11-SA (SB) master box contains a 4 x 9 slot backplane with 22 bit addressing on slots A/B only. The backplane accepts up to nine double-height or nine quad-height modules and is compatible with the RLV21 and the RLV22 options. Dimensions are 13.2 x 48.3 x 57.8 cm (5.2 x 19 x 22.7 in). The power supply comes with a master console and provides 36 amps @+5V and 5 amps @+12V.
- BA23-A,AF,AR** The BA23 master box contains a 4 x 8 22 bit addressing back plane. Slots one through three provide 22 bit addressing on A/B only; slots four through eight provide 22 bit addressing on slots A/B and C/D. Up to eight quad-height or 3 quad and 10 dual height modules can be mounted. The BA23 has mounting space for two RD51 or RX50 mass storage devices.
- Dimensions are:
- BA23-A Chassis—15 x 56.5 x 72.4 cm (6 x 22 x 28 in)  
BA23-AF Floor Mount—61.2 x 25.4 x 71.5 cm (24.5 x 10 x 28 in)  
BA23-AR Rack Mount—13.1 x 47.5 x 64.8 cm (5.25 x 19 x 25 in)
- The power supply comes with a master console and provides 36 amps @+5V and 7 amps @+12V.
- BA11-SE(SF)** The BA11-SE(SF) is a cabinet-mountable eight-slot expansion box with bezel required for 22-bit expansion of the PDP-11/23-PLUS system. Only one expansion box is supported by the PDP-11/23-PLUS. It must be mounted in the CPU cabinet and with the 120 VAC box. A replacement power controller (874-C or 874-D) is required.

## Cables

- BC20N-05** The BC20N-05 is an RS232-C null modem cable with a 10-pin AMP and a female connector. It is used with the DLV11-J and MXV11 to connect directly with an RS232-C cable coming from a terminal. The BC20N-05 is 1.5 m (5 ft) long.
- BC21B-05** This is an RS232-C cable with a 10-pin AMP and a male connector. It can be used with the DLV11-J or the MXV11 to connect to a modem or to the BC20N-05 cable. The BC21B-05 is 1.5 m (5 ft) long.
- BCV1B-06** This jumper cable assembly is used to expand the backplane from the first to second backplane or expansion box. It consists of two modules connected by two 1.8 m (6 ft), 40-conductor Berg to Berg Connectors.
- BCV2A-03** This cable and assembly is used for connecting the CPU box to the BA11-SE(SF) expansion box.

## Backplanes

- H9270** This 4 x 4-slot backplane with card guide is a Q-bus which will accept eight double-height or 4 quad-height boards on slots A/B and C/D. The H9270 is compatible with the RLV12 and RLV22 options.
- H9273-A** This 4 x 9-slot backplane with card guide is a Q-bus which will accept up to nine double-height or quad-height boards on slots A/B and a special module interconnect bus on slots C/D. The H9273 is compatible with the RLV21, and RLV22 options.
- H9275** The H9275 4 x 9-slot backplane with card guide is a non-expandable backplane with 22-bit addressing and built-in bus terminators. It contains the 22-bit bus (Q22) on slots A/B and C/D, and will accept 18 double-height or nine quad-height boards. It is compatible with the RLV12 and RLV22 options.
- H9281** H9281 is a family of 3 backplanes with card guides: the H9281-BA is a 2 x 4-slot backplane where the Q-bus on slots A/B accepts up to 4 double-height modules. The H9281-BB is a 2 x 8-slot backplane with built-in bus terminators, and the Q-bus on slots A/B accepts up to eight double-height boards. The H9281-BC is a 2 x 12-slot backplane which includes bus terminators; the Q-bus on slots A/B accepts up to 12 double-height boards.

# Microcomputer Development Tools

---

## Microcomputer Development Systems (MDS)

11MDS is a new family of microcomputer board-level development systems that provides all of the hardware and software necessary to produce executable, run-time applications for Digital microcomputers. Special hardware features include memory management, floating-point microcode and the ability to downline load and remotely debug applications. 11MDS comes in two software versions: 1) MACSYS/RT-11—includes the RT-11 operating system and supports programs written in MACRO-11 and 2) MicroPower/Pascal—a new application/executive tool kit. Both systems have extensive programming and debugging features to facilitate application development.

11MDS includes the following base hardware:

- PDP-11/23 CPU with MMU
- 128 KB RAM
- Configured VT103-AA with advanced video option
- 4 serial lines (target port, printer port, RX02 connect, auxiliary port)
- Boot ROM
- Diagnostic hardware and software
- Table top RX02 (dual 512 KB)
- Receive-only LA120, 180 cps lineprinter

### Ordering Information:

<b>11MDS-M (A,C,D)</b>	11MDS hardware with MACSYS/RT-11 (QJ061-AX) software
<b>11MDS-P (A,C,D)</b>	11MDS hardware with MicroPower/Pascal (QJ029-XX) software
<b>11MDS-Y (A,C,D)</b>	11MDS hardware with the right to copy RT-11 (Prerequisite: RT-11 supported license)
<b>11MDS-Z (A,C,D)</b>	11MDS hardware with the right to copy MACSYS-RT (Prerequisite: MACSYS supported license)

<b>Key</b>	(A) 120 VAC/60Hz
	(C) 120 VAC/50Hz
	(D) 220 VAC/50Hz

## PB11 PROM Programmer

The PB11 PROM Programmer is a hardware/software package that consists of a desk-top unit and a choice of four adapter kits which make it possible to program a variety of PROM chips. The system connects to a serial line on an RT-11 based Q-bus system. This enables you to transfer a program through the PB11 directly to the PROM.

PB11 is a Desk-Top Universal PROM Programmer with 7.6 m (25 ft) Null Modem RS232-C cable for connection to 11MDS systems using a serial interface with RS232-C cable. Includes Customer-Supported/Customer-Installed software. Adapter Kit must be purchased with the unit.

### Ordering Information:

<b>PB11-AH</b>	Software on RL02 cartridge disk
<b>PB11-AQ</b>	Software on RL01 disk
<b>PB11-AY</b>	Software on RX01 floppy disk
<b>PB11K-AA</b>	Adapter kit for 82S129, 82S131, fusible link PROMs
<b>PB11K-AB</b>	Adapter kit for 2708 UV PROMs
<b>PB11K-AC</b>	Adapter kit for 82S181, 82S191, fusible link PROMs
<b>PB11K-AD</b>	Adapter kit for 2716, 2732 UV PROMs.

## MACDBG-RT

MACDBG is a remote symbolic debugging tool used to debug MACRO-11 level programs running on target Digital microcomputers. MACDBG consists of a program which executes under an RT-11 host system. Communication between MACDBG and the target processors is done via MICRO ODT over a serial line connection from the host to the target processor's console port.

### Ordering Information:

<b>QJ039-AH</b>	RL02 distribution media
<b>QJ039-AX</b>	RX02 distribution media
<b>QJ039-DZ</b>	Documentation-only kit



# Configuring Information

**Processor Configuring Chart**

Option Number	Mounting Code	DC Amps Drawn +5V/ +12V	Bus Loads Drawn AC/DC	Watts
KDF11-AA KEF11-AA KTF11-A FPF11	1 Dual or Double Slot	2.0/0.2	2.0/1.0	10.24 10.24 25.0
KDF11-BA KDF11-BE	1 Quad Slot	4.5/0.3	2.0/1.0	26.1 26.1
KDJ11-AA	1 Dual Slot	4.0/	2.0/1.0	20.0
KXT11-AA KXT11-A2 KXT11-AB KXT11-A5	1 Dual Slot	2.8/1.1	1.7/1.0	27.2 27.2
KXT11-CA	1 Quad Slot	5.0/0.2	2.0/1.0	27.4

**Multifunction Configuring Chart**

Option Number	Mounting Code	DC Amps Drawn +5V/ +12V	Bus Loads Drawn AC/DC	Watts
MXV11-AA MXV11-AC MSV11-A2	1 Dual Slot	1.2/0.1	2.0/2.0	7.2
MSV11-BF MSV11-B2	1 Dual Slot	3.4/0.1	2.3/0.5	16.65

# Configuring Information

**Memory Configuring Chart**

Option Number	Mounting Code	DC Amps Drawn +5V/+12V	Bus Loads Drawn AC/DC	Watts
MCV11-DA	1 Dual Slot	1.9/0.0	1.0/	9.5
MCV11-DC	1 Dual Slot	2.0/0.0	1.0/	10.0
MRV11-C	1 Dual Slot	8.0/0.0	2.0/1.0	4.0
MRV11-D	1 Dual Slot	1.6/0.0	3.0/0.5	8.0
MSV11-DD	1 Dual Slot	1.7/0.37	1.0/	12.94
MSV11-LF MSV11-LK	1 Dual Slot	4.0/0.0	1.0/	20.1 20.1
MSV11-PK MSV11-PL	1 Quad Slot	4.0/0.0	N/A	17.25 17.25

**IEEE Option Configuring Chart**

Option Number	Mounting Code	DC Amps Drawn +5V/+12V	Bus Loads Drawn AC/DC	Watts
IBV11-A	1 Dual Slot	0.8/0.0	1.8/1.0	



# 4 Disks and Tapes

---

Long established as a leader in the manufacture of computer systems, Digital now sets the standard for the design and manufacture of storage systems with its Digital Storage Architecture (DSA). The DSA is a framework for an expanding group of mass storage products and intelligent controllers. Within this framework, the DSA disk drives are all compatible with both DSA intelligent controllers, the UDA50 and for VAX systems, the HSC50. Any drive can be connected to any controller port, and drives can be mixed on the same controller. The drives are all dual-ported and may be connected to a UDA50 by one port and to an HSC50 by the other. The DSA disk drives include the 121 MB RA80 and 456 MB RA81 Winchester Fixed Disks and the 205 MB RA60 Removable-Media Disk. Any combination of up to three of these disks require only one 106.6 cm (42 in) high cabinet giving you maximum storage capacity and space efficiency.

The UDA50 controller has the following capabilities:

- Supports high-speed disk technology.
- Provides powerful error correcting systems for high-density recording.
- Provides multiple level performance optimizations for both single and multiple drive subsystems.
- Provides superior availability features.
- Unburdens the host system of the overhead associated with error handling and I/O throughput optimization.

For long term data backup storage, Digital offers high quality 9-track magnetic tape drives featuring industry standard 1600 b/in and 800 b/in formats. Digital's TU80 and TSV05 magnetic tape subsystems feature start/stop and streaming tape technology.

The Disk and Tape Selection Charts on the facing page include these and other disk and tape subsystems.



# Disks and Tapes

Disk Storage Selection Chart

Model	Capacity per Drive	Average Access Time	Peak Transfer (KB/s)	Media Type	Page
RA60	205 MB	50 msec	1980	Removable	4-10
RA80	121 MB	33msec	1200	Fixed Winchester	4-7
RA81	456 MB	36 msec	2200	Fixed Winchester	4-8
RD51	10 MB	85msec	5000	Fixed Winchester	4-12
RL02	10.4 MB	67 msec	512	Cartridge	4-14
RX02	0.5 MB	262 msec	61	Floppy	4-16
RX50	1.6 MB	164 msec	250	Floppy	4-13

Disks  
and Tapes

# Controllers

---

## The UDA50 Controller

The UDA50 controller implements the Digital Storage Architecture (DSA). It is an intelligent controller containing a high-speed processor that executes host interface and drive interface programs simultaneously. Orderable as a subsystem, the UDA50 can handle data rates up to three MB per second. The physical configuration consists of two hex modules that interface to the PDP-11 UNIBUS. Four disk drives can be connected to a UDA50. The interconnect is radial.

The UDA50 controller and its associated DSA series disks (RA80, RA81, RA60) offer significant improvements in three important areas:

- I/O throughput
- Data integrity
- Subsystem availability

### I/O Throughput Enhancements

I/O throughput depends upon the performance characteristics of the disk, subsystem performance optimization features, and the application workload. In Digital Storage Architecture (DSA) systems, the UDA50 significantly enhances the performance of the disk drive because of the following capabilities:

- **Command Queue**—Stores up to 20 I/O requests providing a mechanism for optimizations.
- **Seek Ordering**—Rearranges and executes requests by cylinder address, improving throughput in single or multidrive subsystems.
- **Overlapped Seeking**—Transfers data from one disk while simultaneously seeking to all disks.
- **Rotational Optimization**—Selects the disk nearest to the beginning sector when more than one disk is positioned on cylinder.
- **Express Queue**—Provides FIFO servicing of I/O requests if required.
- **Speed Matching Buffer**—Provides 52 sectors of Random Access Memory (RAM) allowing disk-to-controller transfers at a higher burst rate than controller-to-host transfers.
- **DMA Transfer**—Allows direct controller-to-host memory transfers.
- **Automatic Revectoring**—References a replacement block on the same or a nearby track when a bad block is encountered, thus enabling users to allocate large contiguous file space without concern for bad blocks.

### Data Integrity Features

The UDA50 controller has the following comprehensive set of features to ensure data integrity:

- **Error Correction Code (ECC)**—Detects and corrects up to eight independent error bursts, reducing the possibility of uncorrected data errors that result from normal media degradation.
- **Redundant Header Addresses**—Records disk block header information four times for more reliable error handling.
- **Automatic Sector Reallocation**—Automatically removes defective blocks from service, and replaces them with others, without causing shrinkage in usable space.
- **Error Detection Code**—Checks controller memory errors as well as ECC hardware operations.
- **Seek Error Recovery**—Checks for mispositioning of disk heads. If mispositioning is detected, the controller will automatically recalibrate and reinitiate seek operation.
- **Data Compare Command**—Compares host data read and write.
- **Error Reporting**—All errors are reported to the host system, enabling detection and preventive action before subsystem failure.
- **Error Recovery Offloading**—All error recovery routines are initiated and completed in the subsystem.

## Subsystem Availability Features

The UDA50 offers the following set of features to increase subsystem availability:

- **Radial Attachment**—Radial disk-to-controller attachments prevent failure in one disk from affecting the operation of other disks in the subsystem.
- **On-board Diagnostics**—Indicates fault conditions on LED displays and in a hardware register that is readable by the host.
- **Bus Isolation**—Different power sources can be used because the drives are isolated electronically from the controller.
- **Last Fault Register**—Aids subsystem troubleshooting by logging the last faults in an error register.

To summarize, the UDA50 does the following:

- Supports high-speed disk technology.
- Provides powerful error correcting systems for high-density recording.
- Provides multiple level performance optimizations for both single and multiple drive subsystems.
- Provides superior availability features.
- Supports Winchester fixed media disks as well as removable media disks of varying capacities and transfer rates.
- Unburdens the host system of the overhead associated with error handling and I/O throughput optimization.

## The RQDX1 Disk Controller

The RQDX1 controller is used to interface the RD51 10 MB Winchester disk drives and the RX50 .8 MB diskette drives to the Q-bus. Data transfer to the host system is via efficient block-mode DMA. The RQDX1 is an intelligent controller with an on-board microprocessor. Programs in the host system communicate with the controller and drives using the Mass Storage Control Protocol (MSCP) of the Digital Storage Architecture. MSCP and the RQDX1 include features to enhance system throughput, ensure data integrity, and increase subsystem availability.

An RQDX1 can control a maximum of four drives. Each RD51 disk counts as one drive, with a maximum of two RD51 units per controller. Each RX50 counts as two drives. The RQDX1 controller may be used in conjunction with the RQDX1-E drive bus extender to attach up to three devices (for example, two RD51s and an RX50) to a single RQDX1 controller.

The RQDX1 is a standard feature of MICRO/PDP-11 systems. It can be added to other Q-bus systems in conjunction with RD51 and RX50 mass storage devices. Refer to the examples of add-on disk configurations.

**Note:** When supporting internal drives on the MICRO/PDP-11, the RQDX1 does not use a panel insert. In other configurations, it uses one type A panel insert.

### Ordering Information:

<b>RQDX1</b>	Q-bus controller for RX50/RD51.
<b>CK-RQDX1-KA</b>	Cabinet kit for the RQDX1 for use in the (MICRO/PDP-11) BA23 box.
<b>CK-RQDX1-KC</b>	Cabinet kit for the RQDX1 for use with (PDP-11/23-PLUS) H349 panel.
<b>RQDX1-E</b>	Double height disk drive bus extender module for use with the RQDX1 disk controller.
<b>CK-RDQXE-KA</b>	Cabinet kit for the RQDX1-E for use in the (MICRO/PDP-11) BA23 box.
<b>CK-RDQXE-KC</b>	Cabinet kit for the RQDX1-E for use with the (PDP-11/23-PLUS) H349 panel.
<b>BQ01-Cx</b>	Country kits for the RQDX1 and RQDX1-E. See the Country Kit section in Section 1 for an explanation of how to replace the x with the appropriate second-letter suffix.

## Add-on Disk Configuration

Various combinations of RD51 Winchester disks and RX50 diskette drives can be added to existing MICRO/PDP-11 and PDP-11/23-PLUS configurations. When you add another RD51 to a MICRO/PDP-11 system, you can use the RQDX1 controller (part of the basic MICRO/PDP-11 system configuration). However, the internal disk drive bus must be extended using the RQDX1-E module and an appropriate cabinet kit. When you add either an RD51 or an RX50 to a PDP-11/23-PLUS system, you must include an RQDX1 controller and appropriate cabinet kit.

Descriptions of the RD51 and RX50 disk options are contained under their own headings.

# Controllers

---

## Ordering Information:

When adding another RD51 to a MICRO/PDP-11, you need the following options:

<b>RQDX1-E</b>	Double height disk drive bus extender module for use with the RQDX1 disk controller.
<b>CK-RQDXE-KA</b>	Cabinet kit for the RQDX1-E for use in the (MICRO/PDP-11) BA23 box.
<b>RD51-D</b>	10 MB Winchester drive mounted in desktop enclosure with I/O cable. 120VAC/240 VAC. For rack-mount configurations, substitute RD51-R for the RD51-D and add an H9302 enclosure, as required, to the order. H9302 can accommodate up to two 5.25-in mass storage devices, RD51 or RX50, in any combination.

When you add an RD51 to a PDP-11/23-PLUS, the following options are required.

<b>RQDX1</b>	Q-bus controller for use with the RD51 and the RX50.
<b>CK-RQDX1-KC</b>	Cabinet kit for the RQDX1 for use with the (PDP-11/23-PLUS) H349 panel.
<b>RD51-D</b>	10 MB Winchester drive mounted in desk-top enclosure with I/O cable. 120VAC/240VAC. For rack-mount configurations, substitute RD51-R for the RD51-D and add an H9302 enclosure, as required, to the order. H9302 can accommodate up to two 5.25-in mass storage devices, RD51 or RX50, in any combination.

When you add an RX50 to a PDP-11/23-PLUS, the following options are required:

<b>RQDX1</b>	Q-bus controller for use with the RD51 and the RX50.
<b>CK-RQDX1-KC</b>	Cabinet kit for the RQDX1 for use with the (PDP-11/23-PLUS) H349 panel.
<b>RX50-D</b>	.8 MB diskette drive mounted in desk-top enclosure with I/O cable. 120VAC/240VAC. For rack-mount configurations, substitute RX50-R for the RX50-D and add an H9302 enclosure, as required, to the order. H9302 can accommodate up to two 5.25-in mass storage devices, RD51 or RX50, in any combination.

Additional configurations, including many with multiple drives, are available. For details, consult your Digital sales representative.

## The RLV12 RLO2 Controller

### Function

The RLV12 controller interfaces one to four RL01 or RL02 disk drives to the Q-bus. I/O is DMA. The RLV12 performs a cyclic redundancy check on data and headers. Memory is parity checked, and the current command to the RLV12 is aborted when the error is detected.

### Ordering Information:

<b>RLV12</b>	Q-bus controller for RL01 and RLO2.
<b>CK-RLV1A-KA</b>	Cabinet kit. For use with BA23 (MICRO/PDP-11).
<b>CK-RLV1A-KB</b>	Cabinet kit. For use with BA11-M (PDP-11/23-S).
<b>CK-RLV1A-KC</b>	Cabinet kit. For use with H349 (PDP-11/23-PLUS).



# RA80 121 MB Fixed-Disk

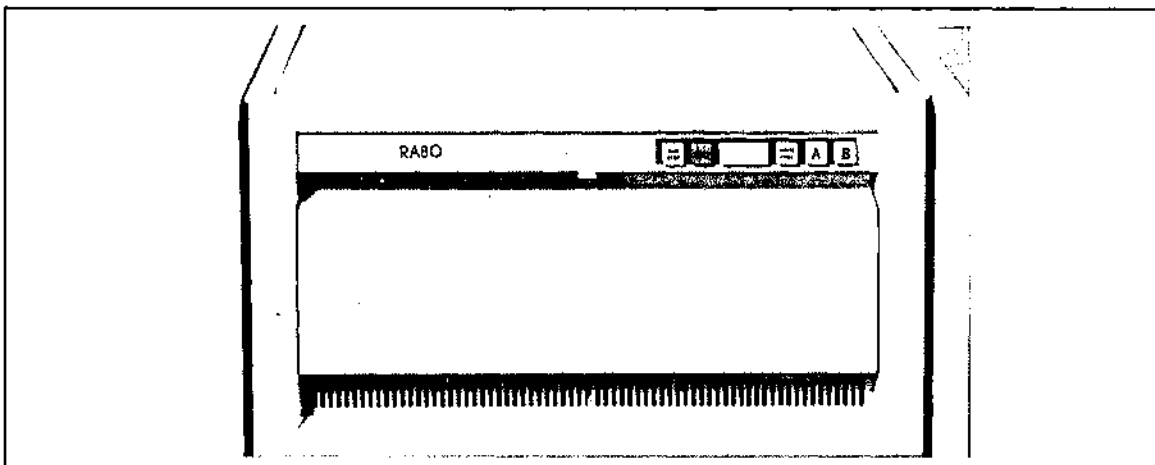

The RA80 disk subsystem uses Winchester fixed-disk technology to provide 121 MB of storage in a 26.6 cm (10.5 in) high package. The RA80 attaches to the high-performance, high-reliability microprocessor-based controller, the UDA50. The RA80 disk offers exceptional throughput performance, the result of an advanced mechanical design, which incorporates a rotary positioner-motor, computer-designed positioner arms, and lightweight Winchester head suspension.

The RA80 provides low-cost mass storage capability with room for growth in a single cabinet. When ordered in a cabinet, a single RA80 drive ships with the H9642-AS(AT) 91.4 cm (36 in) deep cabinet. It mounts in the top bay of the cabinet. Two additional drives (RA80s, RA81s, or RA60s in any combination) can be mounted in the middle and bottom cabinet bays. **Note:** The RA80-AA(AD) rack-mountable drive can be added to the older H9642-BM(BN) shallow cabinet.

One BC26V-12 cable (3.7 m/12 ft) is included with every drive or subsystem to connect the RA60, RA80, or RA81 to a UDA50 controller. If you need a longer cable, or if you want your RA60, RA80, or RA81 dual-ported to another system, order the appropriate cable length from the table following the disk section of this chapter. Substitute the number of feet desired for xx in the option number.

## Expansion Specifications:

- Drives per UDA50 controller: 4

## Performance Specifications:

- Formatted capacity per drive: 121 MB
- Peak transfer rate: 1.2 MB/s
- Average access time\*: 33.3 msec
- Average seek time: 25 msec
- Average latency time: 8.33 msec
- Dual-access feature: Standard
- Media surfaces: 7 data, 1 servo
- Physical tracks per surface: 1092
- User sectors per track: 31
- Bytes per sector: 512
- Single-track seek: 6 msec
- Rotational speed: 3600 rpm

## Ordering Information:

### Subsystems

- RUAB0-AA(AD)** RA80 rack-mountable disk drive (no cabinet) and UDA50 controller.
- RUA80-CA(CD)** RA80 disk drive mounted in H9642-AS(AT) cabinet and UDA50 controller.
- RUA80-JA(JD)** RA80-CA(CD) and two UDA50 controllers.

### Disk Drives

- RA80-AA(AD)** RA80 rack-mountable disk drive (no cabinet).
- RA80-CA(CD)** RA80 disk drive mounted in H9642-AS(AT) cabinet.

### Add-on Controller

- RUA80-UA(UD)** UDA50 controller for upgrading RUA80-CA(CD) to RUA80-JA(JD). Prerequisite: RUA80-CA(CD).

**Note:** Average Access Time is defined as the sum of the average seek time and the average latency. It does not include any controller optimizations. Typical applications will observe 10 to 35 percent better performance than indicated by hardware specifications.

# RA81 456 MB Fixed-Disk

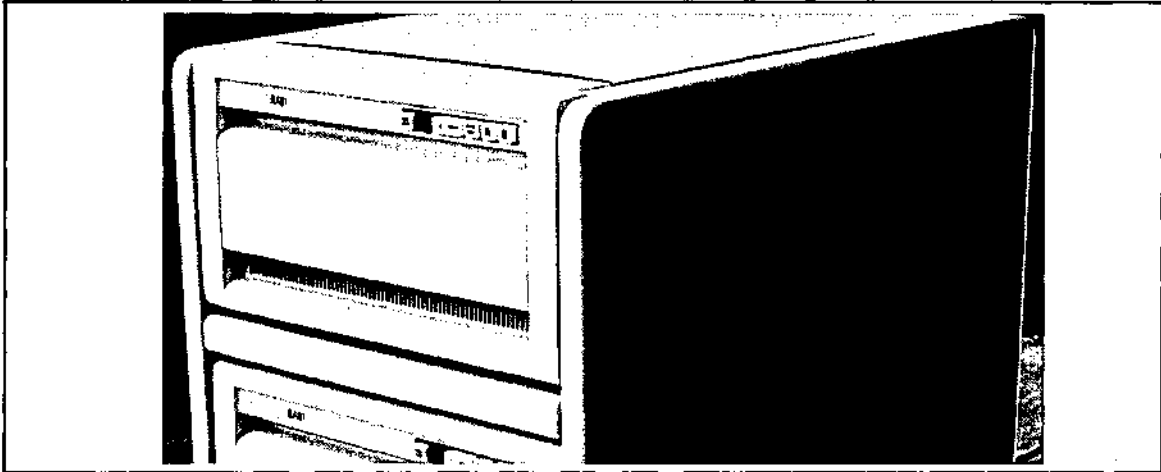

The RA81 disk is a high-capacity, rack-mountable Winchester disk. The RA81 subsystems feature a high-performance, Winchester technology disk drive and the UDA50 intelligent controller. The UDA50 increases I/O throughput, performs extended error recovery, and contains a 52-sector data buffer to match the disk's 2.2 megabyte per second burst data rate to the host system's bus capacity. The RA81's high capacity is achieved through innovative engineering in the read/write and positioner control systems. The read/write system employs an encoding scheme that yields a third greater density than drives using conventional MFM encoding. Positioning information on a dedicated servo surface enables high-speed seeking. Additional positioning information is embedded between sectors on every track for high-precision positioning. The RA81, like all DSA disks, features dual-access, which lets it be shared between two UDA50 controllers, to provide the redundancy required in high-availability systems, or allows sharing of disks between systems. With its 15 KB of on-board diagnostics, the RA81 can be completely diagnosed from a terminal which is connected to an ASCII port on the drive, even when no host computer is available. All error recovery is initiated and completed in the subsystem.

In a three-drive configuration (1.4 GB) that takes only five square feet of floor space, the RA81 is the most space efficient disk drive of its kind. When ordered in a cabinet, a single RA81 drive ships with the H9642-AS(AT) 91.4 cm (36 in) deep cabinet. The RA81 mounts in the top bay of the cabinet. Two additional drives (RA80s, RA81s, or RA60s) can be mounted in the middle and bottom cabinet bays.

**Note:** The RA81-AA(AD) rack-mountable drive can be added to the older H9642-BM(BN) shallow cabinet.

One BC26V-12 cable (3.7 m/12 ft) is included with every drive or subsystem to connect the RA60, RA80, or RA81 to a UDA50 controller. If you need a longer cable, or if you want your RA60, RA80, or RA81 dual-ported to another system, order the appropriate cable length from the table following the disk section of this chapter. Substitute the number of feet desired for xx in the option number.

## Expansion Specifications:

- Drives per UDA50 controller: 4

## Performance Specifications:

- Formatted capacity per drive: 456 MB
- Peak transfer rate: 2.2 MB/s
- Average access time\*: 36.3 msec
- Average seek time: 28 msec
- Average latency time: 8.33 msec
- Dual-access feature: Standard
- Media surfaces: 7 data, 1 servo
- Physical tracks per surface: 2,496
- User sectors per track: 51
- Bytes per sector: 512
- Single-track seek: 6 msec
- Rotational speed: 3600 rpm

**Note:** Average access time is defined as the sum of the average seek time and the average latency. It does not include any controller optimizations. Typical applications will observe 10 to 35 percent better performance than indicated by hardware specifications.

# RA81 456 MB Fixed-Disk

---

## Ordering Information:

### Subsystems

- RUA81-AA(AD)** RA81-AA(AD) rack-mountable drive (no cabinet) and UDA50 controller.
- RUA81-CA(CD)** RA81-CA(CD) disk drive mounted in H9642-AS(AT) cabinet, and UDA50 controller.
- RUA81-EA(ED)** RA81-EA(ED) (three drives) in H9642-AS(AT) cabinet and UDA50 controller.
- RUA81-JA(JD)** RA81-CA(CD) and two UDA50 controllers.

### Disk Drives

- RA81-AA(AD)** RA81 rack-mountable disk drive (no cabinet).
- RA81-CA(CD)** RA81-AA(AD) disk drive, mounted in H9642-AS(AT) cabinet.
- RA81-EA(ED)** Three RA81-AA(AD) drives, mounted in H9642-AS(AT) deep cabinet.

### Additional Controller

- RUA80-UA(UD)** UDA50 controller for upgrading RUA81-CA(CD) to RUA81-JA(JD).  
Prerequisite: RUA81-CA(CD).

**Note:** Order number RUA80-UA(UD) applies to RA80, RA81, and RA60 disk drives.

# RA60 205 MB Removable-Media Disk

---

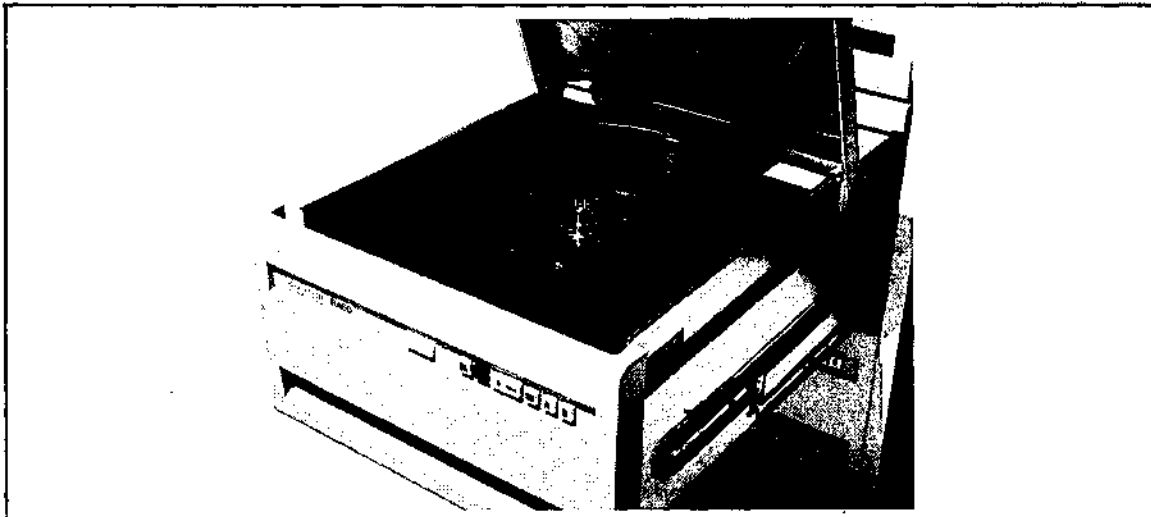

The RA60 is a high-capacity, rack-mountable, removable-media disk. The recording density is three times that of the most commonly available removable disk, which means that the RA60 offers the lowest life-time cost-of-ownership per megabyte of all removable-media disks in the industry. The RA60 subsystem operates with the UDA50 controller, which provides several levels of performance optimization to improve I/O throughput. A seek-ordering algorithm will reorder up to 20 I/O requests in the UDA50's command queue to minimize seek time, in both single- and multidrive subsystems. The UDA50 controller allows the user to mix RA60 disk drives with RA80 or RA81 disk drives.

The RA60 disk drive uses embedded servo technology exclusively, which eliminates the need for alignment procedures and provides unprecedented levels of pack interchange among drives. It also incorporates new recording methods, microprocessor controlled diagnostics, 170-bit error correcting code, and modular design for easy maintenance. RA60 disk packs can be interchanged among drives without restriction or degradation in data reliability.

When ordered in a cabinet, a single RA60 drive ships with the H9642-AP(AR) 91.4 cm (36 in) deep cabinet. The RA60 mounts in the top bay of the cabinet. Two additional drives (RA80s, RA81s, or RA60s in any combination) can be mounted in the middle and bottom cabinet bays.

One BC26V-12 cable (3.7 m/12 ft) is included with every drive or subsystem to connect the RA60, RA80, or RA81 to a UDA50 controller. If you need a longer cable, or if you want your RA60, RA80, or RA81 dual-ported to another system, order the appropriate cable length from the table following the disk section of this chapter. Substitute the number of feet desired for the xx in the option number.

## Expansion Specifications:

- Drives per UDA50 controller: 4

## Performance Specifications:

- Formatted capacity per drive: 205 MB
- Peak transfer rate: 1.98 MB/s
- Average access time\*: 50 msec
- Average seek time: 41.7 msec
- Average latency time: 8.33 msec
- Dual-access feature: Standard
- Media surfaces: 6 data
- Physical tracks per surface: 1,600
- User sectors per track: 43
- Bytes per sector: 512
- Single-track seek: 6.7 msec
- Rotational speed: 3600 rpm

**Note:** Average Access Time is defined as the sum of the average seek time and the average latency. It does not include any controller optimizations. Typical applications will observe 10 to 35 percent better performance than indicated by hardware specifications.

# RA60 205 MB Removable-Media Disk

## Ordering Information:

### Subsystems

- RUA60-AA** RA60-AA and UDA50 controller; no cabinet.
- RUA60-CA(CD)** RA60-CA(CD) disk drive mounted in H9642-AP(AR) cabinet and UDA50 controller.
- RUA60-JA(JD)** RA60-CA(CD) disk drive, mounted in H9642-AP(AR) cabinet and two UDA50 controllers.

### Disk Drives

- RA60-CA(CD)** RA60-AA disk drive, mounted in H9642-AP(AR) deep cabinet.
- RA60-AA** RA60 rack-mountable disk drive (no cabinet).

### Add-on Controller

- RUA80-UA(UD)** UDA50 controller for upgrading RUA60-CA(CD) to RUA60-JA(JD). Prerequisite: RUA60-CA(CD).

**Note:** Order number RUA80-UA(UD) applies to RA80, RA81, and RA60 disk drives.

### Cables for RA80, RA81, and RA60 Disk Drives

Option	Length	Where Used
BC26V-XX	3.7 m (12 ft) 7.6 m (25 ft) 15.2 m (50 ft) 24.4 m (80 ft)	Connects one RA81, RA80, or RA60 disk drive to a UDA50 controller

# RD51 Disk Drive

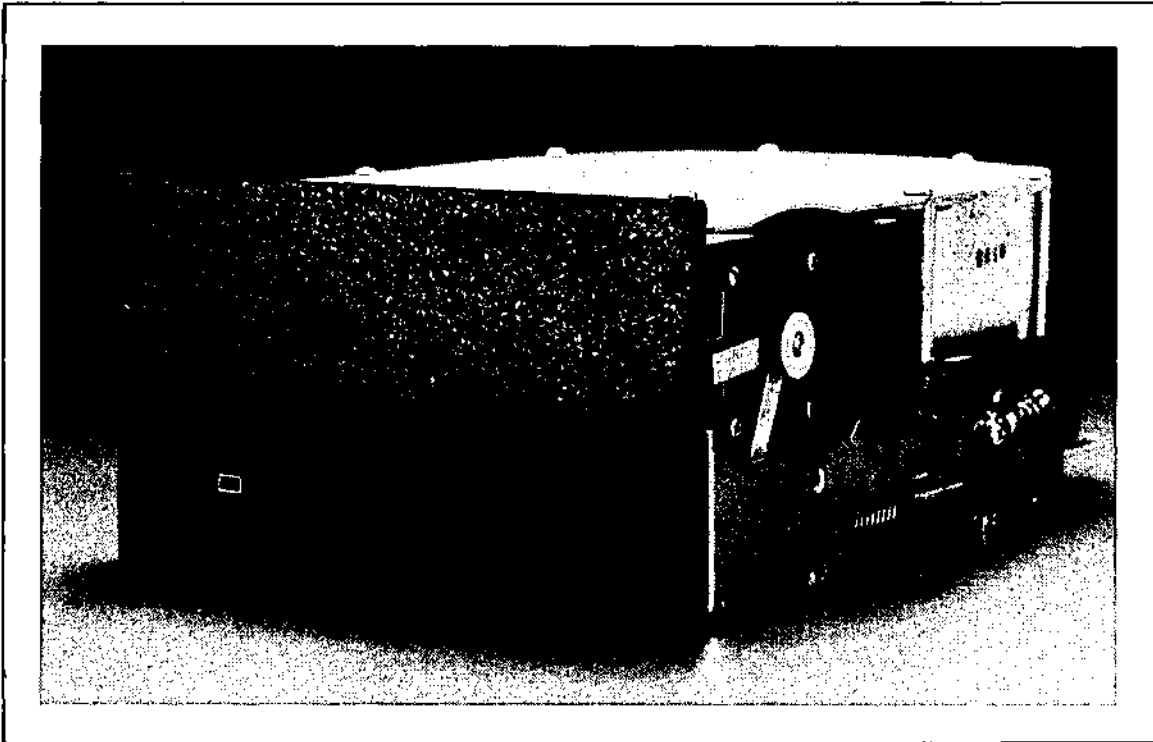

The RD51 is a 10-MB, non-removable disk drive, utilizing state-of-the-art Winchester technology. The drive mechanism is packaged in a single compact housing, which conforms to the industry standards for 5.25-in disk media. The sealed head/disk assembly (HDA) contains two platters, four read/write heads and positioning arm. The sealed HDA helps to increase drive reliability and ensure data integrity.

The RD51 is available in two distinct packaging styles. The RD51-A is intended to be 'added-into' a system enclosure, such as the MICRO/PDP-11. The RD51-D and RD51-R are intended to be mounted in their own separate desk-top or rack-mount enclosures, and 'added-on' to a system, such as a PDP-11/23-PLUS or MICRO/PDP-11. Refer to examples of add-on disk configurations.

## Performance Specifications:

- Average access time: 85 msec
- Average rotational latency: 8.33 msec
- Transfer rate: 5 MB/s

## Media Characteristics:

- Formatted capacity: 11.059 MB
- Recording surfaces (heads): 4
- Bytes per sector: 512
- Sectors per track: 18
- Track per drive: 1,200
- Recording method: Modified Frequency Modulation (MFM)

## Ordering Information:

<b>RD51-A</b>	10 MB Winchester disk drive
<b>RD51-D</b>	10 MB Winchester drive mounted in desk-top enclosure with I/O cable. 120VAC/240VAC.
<b>RD51-R</b>	10 MB Winchester drive for mounting in 19-in standard equipment rack. 120VAC/240VAC. Requires H9302 enclosure.
<b>H9302</b>	Rack-mount chassis for use with up to two 5.25-in mass storage devices, RD51 or RX50, in any combination.
<b>BQ01-Dx</b>	Country kits for use with RD51-D and RD51-R. See the Country Kit section of Chapter 1 for the explanation of how to change the x to the appropriate second-letter suffix.

# RX50 .8 MB Diskette Drive

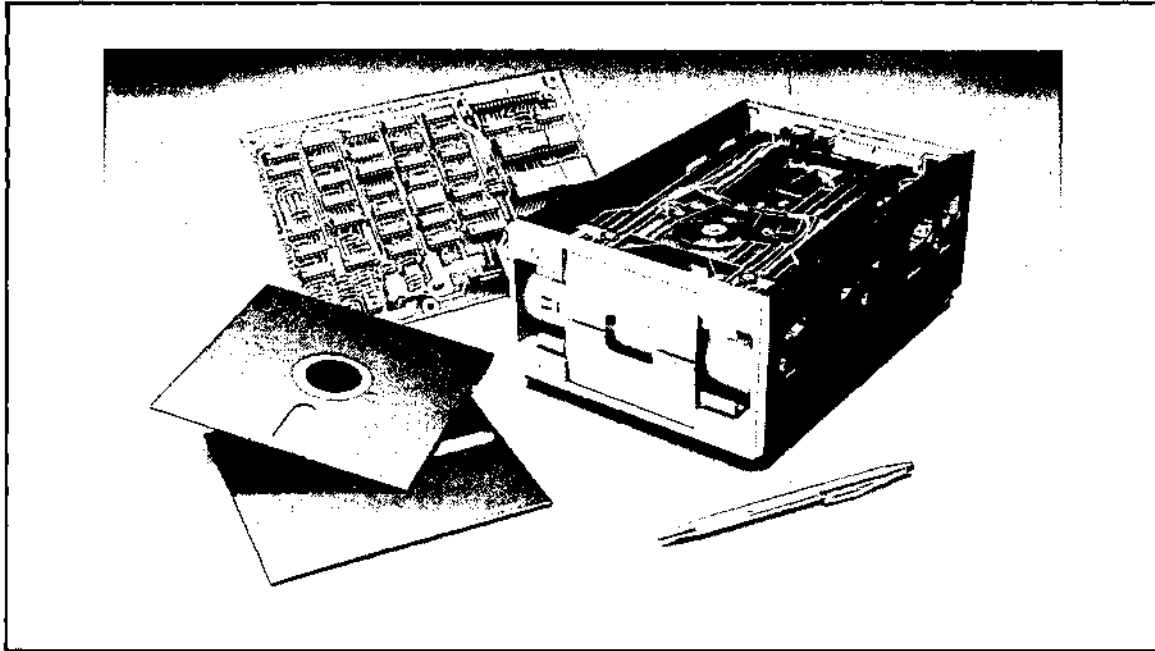

The RX50 dual diskette drive is a low-cost, compact, random access diskette drive. It stores data in fixed-length blocks on two 5.25-in flexible diskettes using preformatted industry-standard headers. Since the drive can accommodate two diskettes simultaneously, one diskette can be used for system programs, and the other allocated as a file device. The drive mechanism is packaged in a single compact housing, and its dimensions conform to the industry standards for 5.25-in disk media.

The RX50 is available in two distinct packaging styles. The RX50-AA is intended to be 'added-into' a system enclosure, such as the MICRO/PDP-11. The RX50-D and RX50-R are intended to be mounted in their own separate desk-top or rack-mount enclosures, and 'added-onto' a system, such as a PDP-11/23-PLUS or MICRO/PDP-11. Refer to examples of add-on disk configurations.

## Performance Specifications:

- Peak transfer rate: 250 KB/s
- Average seek time: 164 msec
- Rotational latency (average): 100 msec

## Media Characteristics:

- Formatted capacity per diskette: 409 KB (818 KB total)
- Diskettes per drive: 2
- Recording surfaces per diskette: 1
- Bytes per sector: 512
- Sectors per track: 10
- Tracks per diskette: 80

## Ordering Information:

<b>RX50-AA</b>	.8 MB diskette drive (only).
<b>RX50-D</b>	.8 MB diskette drive mounted in desk-top enclosure with I/O cable. 120VAC/240VAC.
<b>RX50-R</b>	.8 MB diskette drive for mounting in 19 in standard equipment rack. 120VAC/240VAC. Requires H9302 enclosure.
<b>H9302</b>	Rack-mount chassis for use with up to two 5.25-in mass storage devices, RD51 or RX50, in any combination.
<b>BQ01-Ex</b>	Country kits for use with RX50-D and RX50-R. See Chapter 1 for the explanation of how to replace the x with the appropriate second-letter suffix.

# RLO2 10 MB Cartridge Disk Drive

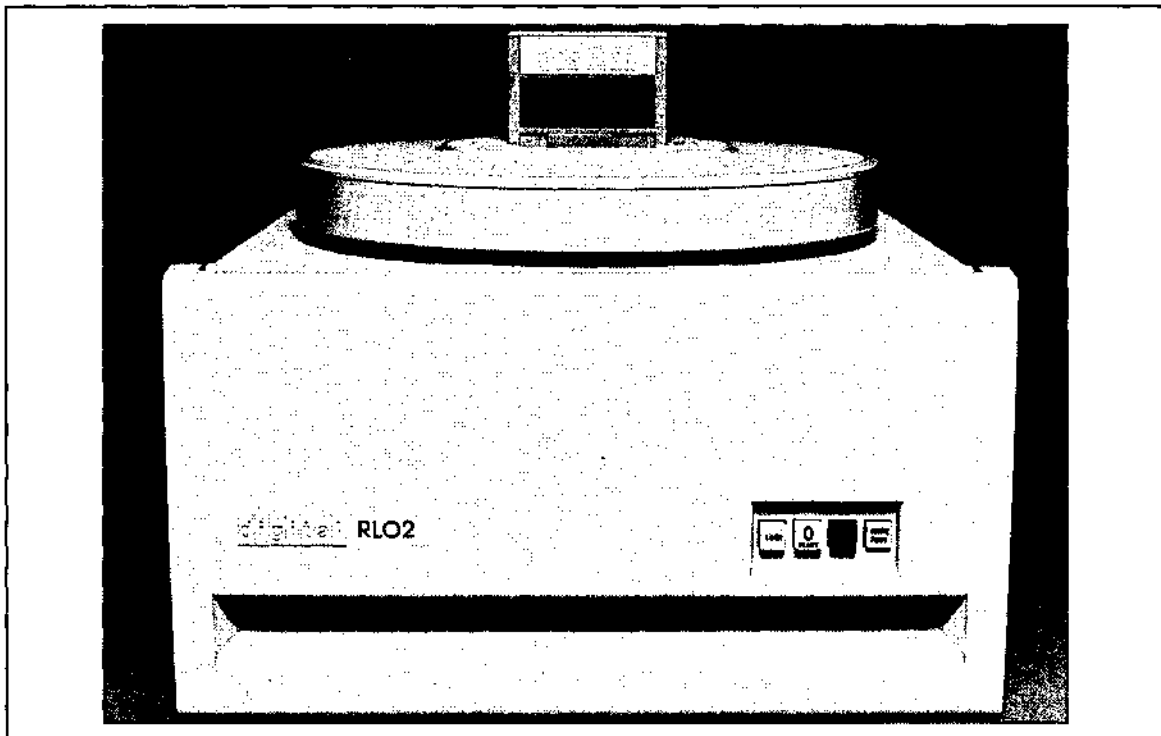

The RLO2 combines reliability and cartridge disk convenience in a low-cost, medium-capacity mass storage device. An embedded closed-loop servo positioning system improves data integrity by continuously sampling servo information with the same head that reads and writes the data. To further ensure data integrity, a cyclic redundancy check (CRC) is performed on data transfers between the drive and controller. Also, a phase-locked-loop clock system and modified frequency modulation (MFM) recording provide reliable reading and recording techniques. Direct memory access (DMA) is used to provide rapid data transfer and efficient utilization of the host processor.

## Expansion Specifications:

- Drives per controller: 4
- Maximum controllers per CPU: 2

## Performance Specifications:

- Formatted capacity per drive: 10.4 MB
- Peak transfer rate: 512 KB/s
- Average access time: 67.5 msec
- Average seek time: 55 msec
- Average latency time: 12.5 msec
- Dual-port option: No
- Media surfaces: 2 data
- Tracks per surface: 512
- Sectors per track: 40
- Bytes per sector: 256
- Track-track seek: 15 msec
- Rotational speed: 2400 rpm

**Note:** Average access time is defined as the sum of the average seek time plus the average latency.



# RLO2 10 MB Cartridge Disk Drive

---

## Ordering Information:

### Subsystems

- RL211-AK** Rack-mounting removable-cartridge disk drive and controller to interface to the PDP-11 UNIBUS.
- RLV22-AP** System option. Rack-mounting removable-cartridge disk drive and controller to interface to the Q-bus.

### Controller

- RLV12** The RLV12 controller interfaces one to four RLO1 or RLO2 disk drives to the Q-bus. I/O is DMA. The RLV12 performs a cyclic redundancy check on data and headers. Memory is parity checked, and the current command to the RLV12 is aborted when the error is detected.
- RLV12-AP** System option. Includes module, internal cables, and I/O connector panel insert. This option must be ordered with the system in which it is to be installed.
- CK-RLV1A-KA** Cabinet kit. For use with BA23 (MICRO/PDP-11).
- CK-RLV1A-KB** Cabinet kit. For use with BA11-M (PDP-11/23-S).
- CK-RLV1A-KC** Cabinet kit. For use with H349 (PDP-11/23-PLUS).
- RLV22-AK** Upgrade option for the Q-bus. Order one of the following cabinet kits:
- CK-RLV1A-KA** Cabinet kit. For use with BA23 (MICRO/PDP-11).
- CK-RLV1A-KB** Cabinet kit. For use with BA11-M (PDP-11/23-S).
- CK-RLV1A-KC** Cabinet kit. For use with H349 (PDP-11/23-PLUS).

### Additional Disk Drives

- RLO2-AK** Rackmount removable cartridge disk add-on drive.

# RX02 1.0 MB Floppy Disk Subsystem

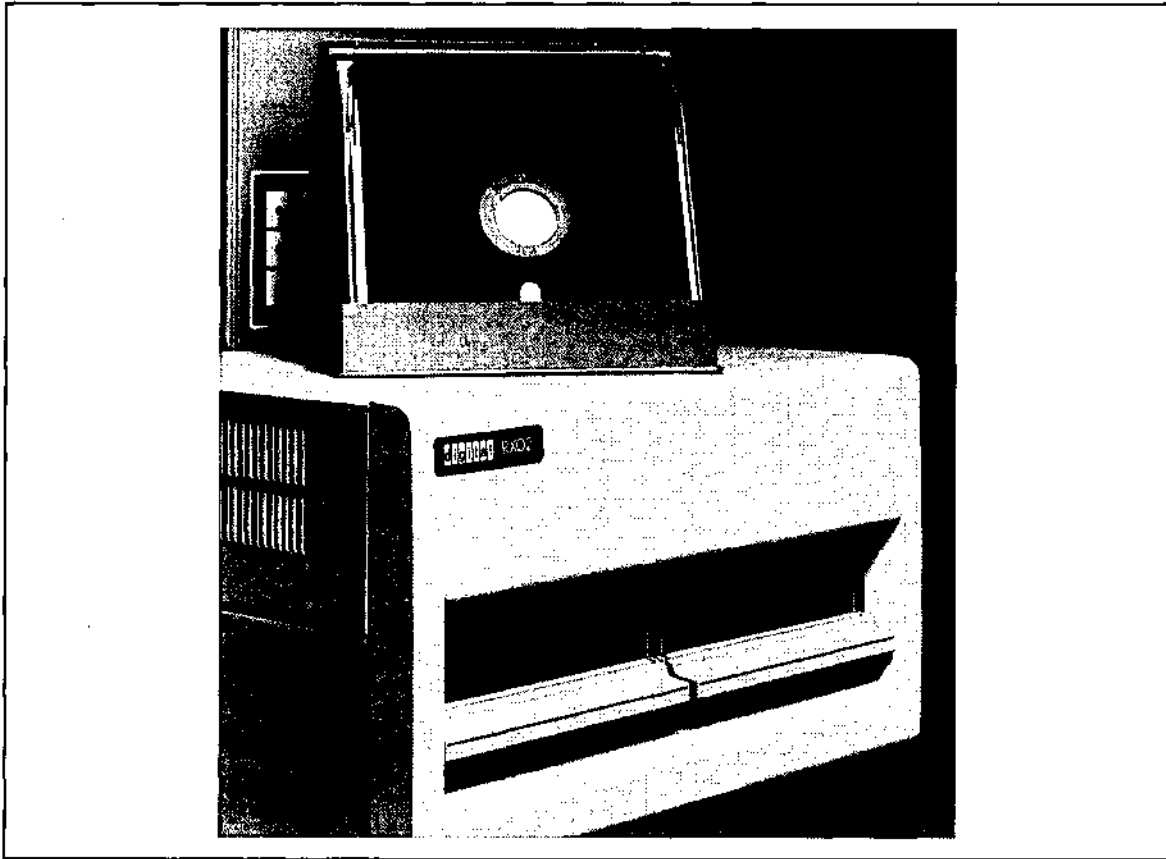

The RX02 double-density floppy disk drive provides an industry-compatible format and highly reliable operation. Direct memory access (DMA) is used to provide rapid data transfer and efficient utilization of the host processor. These subsystems include two RX02 0.5 MB drives (for a total of one MB) and a controller with interconnect cabling. The dual drives are packaged as a cabinet-mountable or tabletop unit.

## Expansion Specifications:

- Drives per controller: 2

## Performance Specifications:

- Formatted capacity per drive: 0.5 MB (1 MB total)
- Peak transfer rate: 61 KB/s
- Average access time: 262 msec
- Average seek time: 154 msec
- Average settling time: 25 msec
- Average latency time: 83 msec
- Dual-port option: No
- Media surfaces: 1 data
- Tracks per surface: 77
- Sectors per track: 26
- Bytes per sector: 256
- Track-track seek: 6 msec
- Rotational speed: 360 rpm

## Ordering Information:

- RX211-BK(BM, BN)** Rack-mount dual RX02 floppy disk drives and controller to interface to the PDP-11 UNIBUS.
- RXV21-EP(ES, ET)** System option. Tabletop dual RX02 floppy disk drive and controller to interface to the Q-bus.
- RXV21-EA(ED, EC)** Upgrade option for the Q-bus. Order one of the following cabinet kits:
- CK-RXV2E-KA** Cabinet kit. For use with BA23 (MICRO/PDP-11).
- CK-RXV2E-KB** Cabinet kit. For use with BA11-M (PDP-11/23-S).
- CK-RXV2E-KC** Cabinet kit. For use with H349 (PDP-11/23-PLUS).

**Note:** Average access time is defined as the sum of the average seek time plus the average settling time plus the average latency.

# Configuring Information

## UNIBUS Disks

Disk Option	Mounting Code	DC Amps Drawn @ +5V/+15V/-15V	Bus Loads Drawn	Panel Units
RL211-AK	1 Hex Slot	5.0/0.5/0.5	1	1
RL211-BK(BN)	1 Quad Slot	1.5/0.0/0.0	1	1
RUA80 RUA81 RUA60	2 Hex Slots	12.75/0.04/1.3	1	1

## Q-bus Disks

Disk Option	Mounting Code	DC Amps Drawn @ +5V/+12V	Watts Drawn	Bus Loads (AC/DC)	Panel Inserts
RLV12-AP RLV22-AP	1 Quad Slot 2 Quad Slots, Panel	5.0/.10 6.5/1.0	26.2 44.5	2.7/1.0 3/1	A A
RQDX1	1 Quad Slot	6.4/.25	35	2/1	A
RXV21-EP(ET,ES)	1 Dual Slot	2.2/0.0	11	2/1	A
RQDX1-E	1 Dual Slot	.5/0.0	2.5	0/0	A
RD51-A	Dedicated Space	1.0/1.8	25.6	0/0	None
RX50-AA	Dedicated Space	.8/1.8	25.6	0/0	None

Disks  
and Tapes

# Disk Site Preparation

**Disk Site Preparation**

Disk Option	Height	Width	Depth	Weight	BTU/Hr	Watts
<b>RA60 In Cabinet</b>	106.2 cm 41.8 in	54.1 cm 21.3 in	91.4 cm 36 in	168 kg 370 lbs	2400	703
<b>RA60 Rackmount</b>	26.7 cm 10.5 in	44.5 cm 17.5 in	85.1 cm 33.5 in	75 kg 165 lbs	2400	703
<b>RA80 In Cabinet</b>	106.2 cm 41.8 in	54.1 cm 21.3 in	91.4 cm 36 in	185 kg 363 lbs	2200	645
<b>RA80 Rackmount</b>	26.4 cm 10.4 in	44.5 cm 17.5 in	67.3 cm 26.5 in	67.3 kg 148 lbs	2200	645
<b>RA81 In Cabinet</b>	106.2 cm 41.8 in	54.1 cm 21.3 in	91.4 cm 36 in	185 kg 363 lbs	2200	645
<b>RA81 Rackmount</b>	26.4 cm 10.4 in	44.5 cm 17.5 in	67.3 cm 26.5 in	67.3 kg 148 lbs	2200	645
<b>RL02 Rackmount</b>	26.7 cm 10.5 in	48.3 cm 19 in	63.5 cm 25 in	34.1 kg 75 lbs	546	160
<b>RX02 Rackmount</b>	26.7 cm 10.5 in	48.3 cm 19 in	43.2 cm 17 in	27.2 kg 60 lbs	1960	575
<b>RX50 Rackmount</b>	8.33 cm 3.25 in	14.74 cm 5.75 in	21.53 cm 8.5 in	1.72 kg 3.8 lbs	61.4	18
<b>RD51-D</b>	13.3 cm 5.25 in	22.9 cm 9 in	30.2 cm 11.9 in	6.3 kg 14 lbs	144	42
<b>RD51-R</b>	13.3 cm 5.25 in	22.9 cm 9 in	30.2 cm 11.9 in	5.0 kg 11 lbs	144	42
<b>RX50-D</b>	13.3 cm 5.25 in	22.9 cm 9 in	30.2 cm 11.9 in	6.3 kg 14 lbs	127	37
<b>RX50-R</b>	13.3 cm 5.25 in	22.9 cm 9 in	30.2 cm 11.9 in	5.0 kg 11 lbs	127	37

# Magnetic Tapes

Magnetic Tape Selection Chart

Model	Capacity Per Reel (8 KB blocks)	Density (b/in)	Speed (in/s)	CPU	Media Type	Page
TE16	40 MB	800-1600 2032-4064	45 114.3	UNIBUS	1.27 cm 0.5 in Reel to Reel	4-23
TSV05	40 MB	1600 4064	25/100 63.5/254	Q-bus	1.27 cm 0.5 in Reel to Reel	4-21
TU58	0.5 MB	800 2032	30 76.2	UNIBUS Q-bus	Cartridge	4-24
TU77	40 MB	800-1600 2032-4064	125 317.5	UNIBUS	1.27 cm 0.5 in Reel to Reel	4-22
TU80	40 MB	1600 4064	25/100 63.5/254	UNIBUS	1.27 cm 0.5 in Reel to Reel	4-20

Disks  
and Tapes

# TU80 Magnetic Tape



The TU80 UNIBUS magnetic tape subsystem includes the controller, cabinet with horizontally mounted tape drive, and all necessary cabling. It is a 1600 b/in (phase encoded), 25/100 in/s, .05 in subsystem. It employs start/stop and streaming tape technology. Because the TU80 has no vacuum columns, no tension arms, no capstans, no roller guide bearings, and no complicated tape paths, it is more compact and easier to use than equivalent start/stop systems. Instead, it employs microprocessor servo systems and air bearings for high reliability.

## Performance Specifications:

- Recording density: 1600 b/in
- Read/write speed: 25 in/s (start/stop)  
25/100 in/s streaming)
- Capacity per 2400 ft reel:  
40 MB with 8 KB blocks @ 1600 b/in
- Maximum data transfer rate: 160 KB

## Ordering Information:

- TU80-AA(AB)** TU80 magnetic tape subsystem. Includes tape drive, cabinetry, power controller, a shielded 3.7 m (12 ft) inter-cabinet cable and a UNIBUS adapter module.

**Note:** The TU80 can be ordered with an RA80 or RA81 disk for mounting in the same cabinet. Order the rack-mount disk option which does not include a cabinet. Example: RA80-AA(AD).

# TSVO5 Magnetic Tape

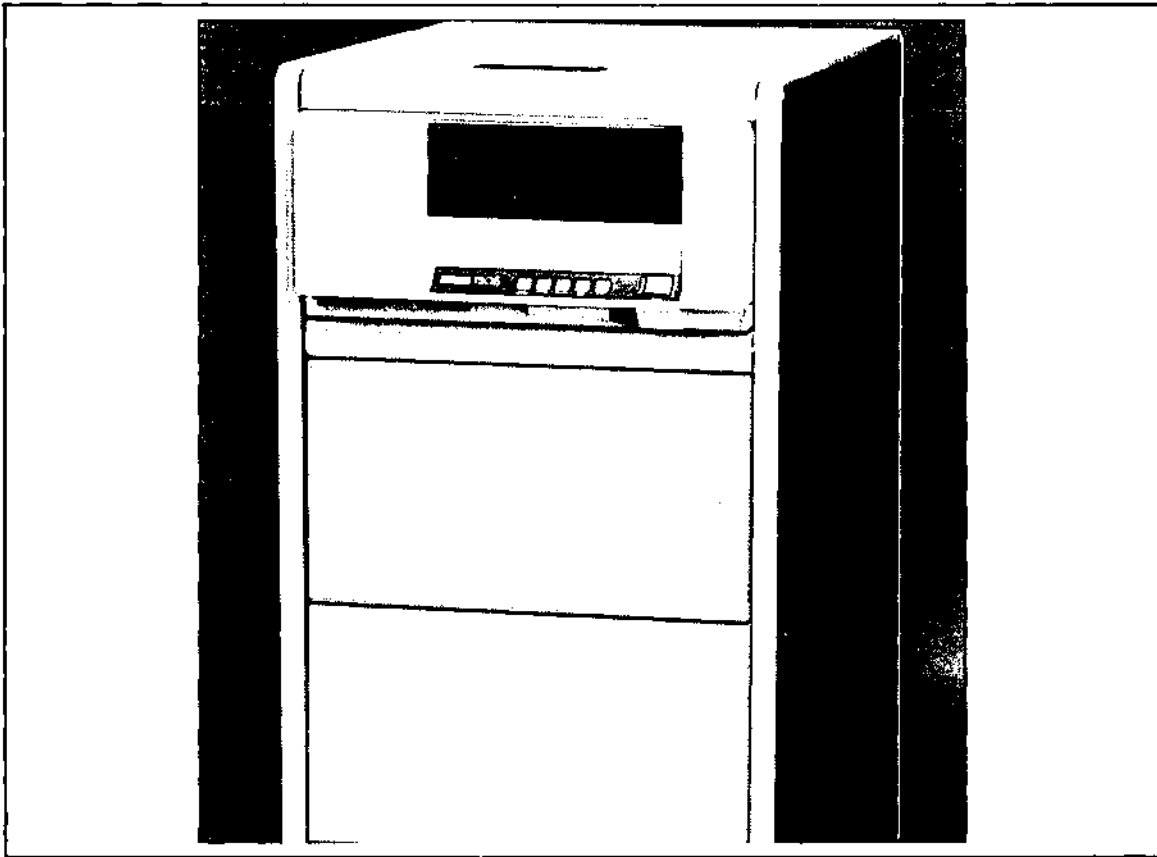

Disks  
and  
Tapes

The TSV05 Q-bus magnetic tape subsystem includes a tape transport with an integral formatter and a single quad-size bus interface/controller module. This module plugs into any quad-size slot in a Q-bus/extended Q-bus backplane, and communicates with one tape transport using standard software. The tape transport occupies only 8.7 in, in a H9642-type 106.6 cm (42 in) cabinet, thus allowing ample room for expansion. It is a high performance .05-in subsystem incorporating streaming technology, and is the only Digital tape subsystem available for Q-bus systems. It offers industry-standard 1600 b/in Phase Encoded format, ANSI compatibility, a storage capacity of up to 40 MB using 8 KB blocks, high-speed streaming backup, and front loading automatic tape threading operation. The TSV05 is also available without the cabinet for system integrators.

## Expansion Specifications:

- Transports per controller: 1

## Performance Specifications:

- Recording density: 1600 b/in
- Read/write speed: 25/100 in/s
- Capacity per 2400 ft reel:  
40 MB with 8 KB blocks @ 1600 b/in
- Maximum data transfer speed: 40 or 160 KB/s
- Rewind Speed: 180 in/s (max)
- Rewind Time: 2.8 minutes per 2400 ft reel

## Ordering Information:

The Prerequisite for the TSV05 is the PDP-11/23-PLUS.

<b>TSV05-BA(BB)</b>	TSV05 magnetic tape system mounted in a 101.6 cm (40 in) H9642-type cabinet with power controller and 53.3 cm (21 in) expansion. No side panels
<b>TSV05-BC</b>	Same as TSV05-BA(BB) except 100VAC system.
<b>TSV05-BD</b>	Same as TSV05-BA(BB) except 220VAC system.
<b>TSV05-AA(AB)</b>	TSV05 magnetic tape system with mounting hardware, control module and cables.
<b>TSV05-AC</b>	Same as TSV05-AA(AB) except 100VAC system.
<b>TSV05-AD</b>	Same as TSV05-AA(AB) except 220VAC system.

# TU77 Magnetic Tape

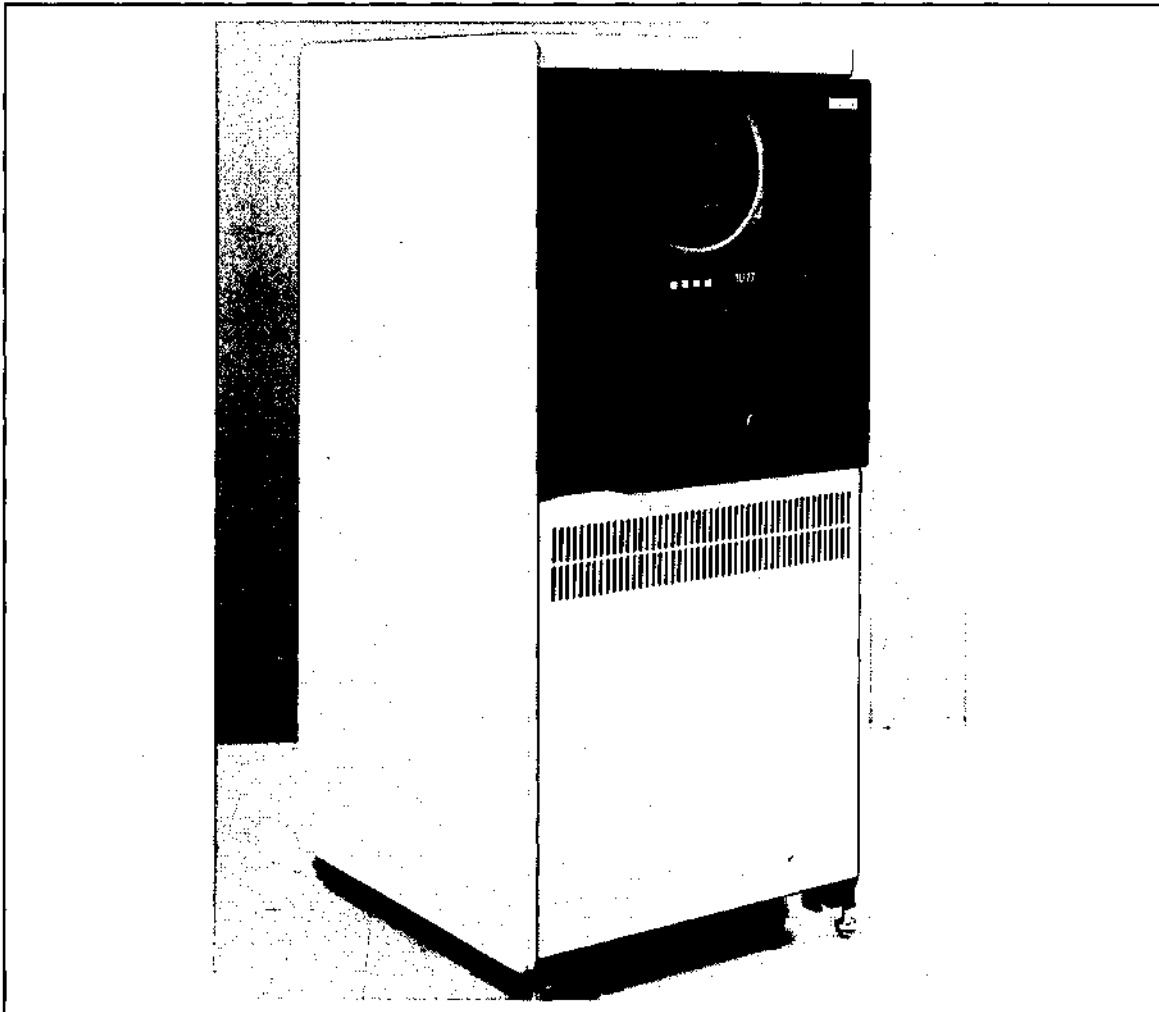

The TU77 UNIBUS magnetic tape subsystem includes the controller, a tape formatter, and one nine-track TU77 tape transport. The TU77 tape transport uses industry-compatible recording densities of 1600 b/in (Phase Encoded) and 800 b/in (Non-Return to Zero Inverted) selectable under program control. The subsystem is available with controllers for UNIBUS PDP-11 systems. The TU77 tape transport is available mounted in a 152.4 cm (60 in) H9602 single-width highboy cabinet.

## Expansion Specifications:

- Transports per controller: 4

## Performance Specifications:

- Recording density: 1600 b/in ;800 b/in
- Read/write speed: 125 in/s
- Capacity per 2400 ft reel:
  - 40 MB with 8 KB blocks @ 1600 b/in
  - 20 MB with 8 KB blocks @ 800 b/in
- Maximum data transfer speed:
  - 200 KB/sec @1600 b/in
  - 100 KB/sec @ 800 b/in
- Rewind speed: 440 in/s
- Rewind time: 70 sec per 2400 ft reel

## Ordering Information:

### Subsystem

**TJU77-AB(AD)** TU77 magnetic tape transport and controller to interface to the PDP-11 UNIBUS.

### Additional Tape Drives

**TU77-AF(AJ)** Magnetic tape transport.



# TE16 Magnetic Tape

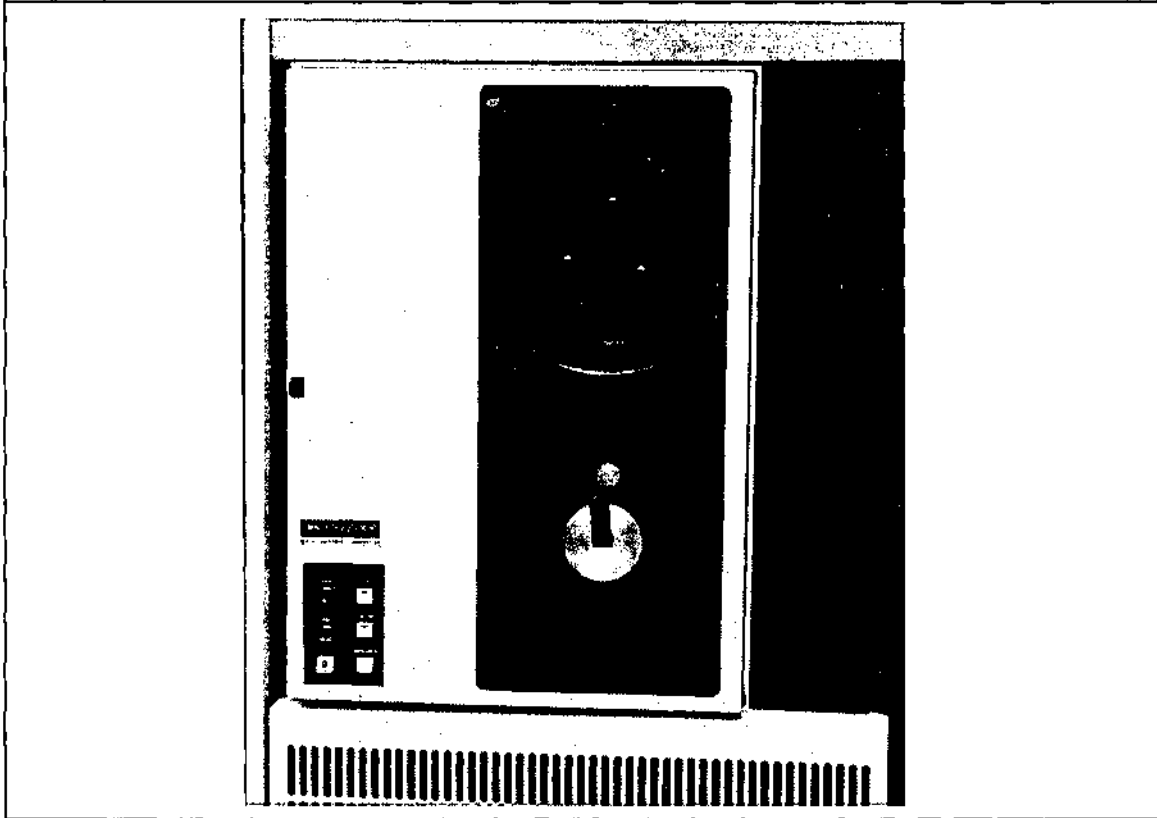

The TE16 UNIBUS magnetic tape subsystems include the controller, a tape formatter, and one nine-track TE16 tape transport. The TE16 tape transport uses industry-compatible recording densities of 1600 b/in (Phase Encoded) and 800 b/in (Non-Return to Zero Inverted) selectable under program control. The subsystem is available with controllers for PDP-11 UNIBUS systems. The TE16 tape transport is available mounted in a 152.4 cm (60 in) H9602 single-width highboy cabinet.

## Expansion Specifications:

- Transports per controller: 8

## Performance Specifications:

- Recording density: 1600 b/in, 800 b/in
- Read/write speed: 46 in/s
- Capacity per 2400 ft reel:
  - 40 MB with 8 KB blocks @ 1600 b/in
  - 20 MB with 8 KB blocks @ 800 b/in
- Maximum data transfer speed:
  - 72 KB/s @ 1600 b/in
  - 36 KB/s @ 800 b/in
- Rewind speed: 150 in/s
- Rewind time: 3.7 minutes per 2400 ft reel

## Site Preparation Specifications:

- Height: 152.4 cm (60 in)
- Width: 71 cm (28 in)
- Depth: 76.2 cm (30 in)
- Weight: 227 kg (500 lb)
- Watts: 900
- Btu/hr: 3100
- Receptacles:
  - NEMA #L5-30R (120VAC/60Hz),
  - NEMA #6-20R (240VAC/50Hz)

## Ordering Information:

### Subsystem

- TJE16-AA(AD)** TE16 magnetic tape transport and controller to interface to the PDP-11 UNIBUS. Mounted in a 152.4 cm (60 in) H9602 single-width highboy cabinet.

### Additional Tape Drives

- TE16-AE(AJ)** Additional magnetic tape transport mounted in a 152.4 cm (60 in) H9602 single-width highboy cabinet.

# TU58 Cartridge Tape

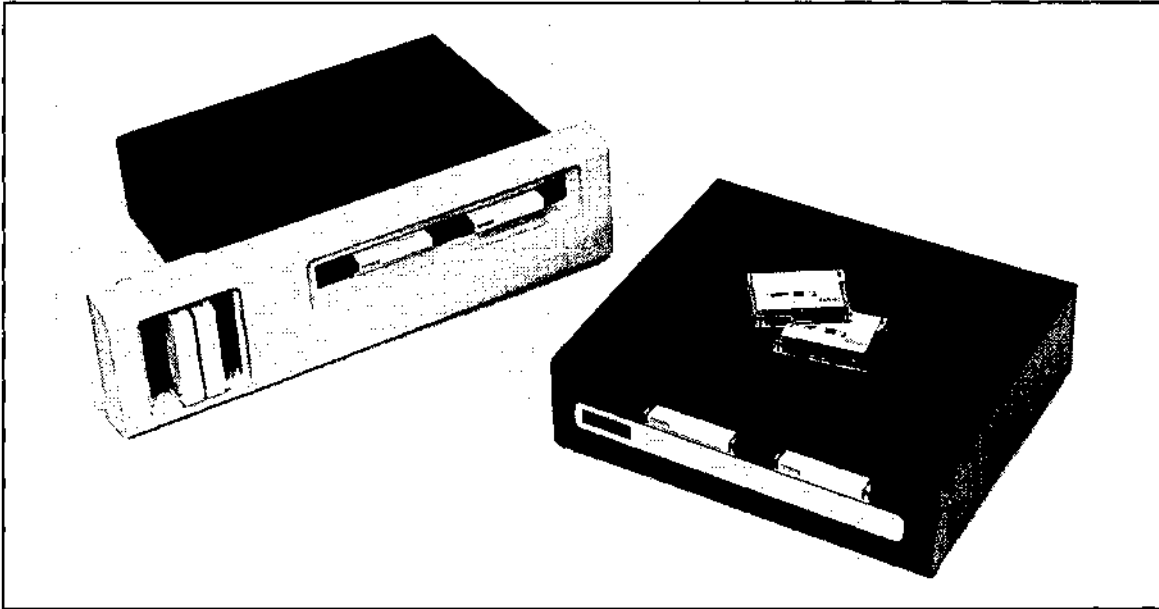

The TU58 UNIBUS dual-drive cartridge tape subsystems are random access, mass memory storage devices that read and write data on block-addressable, preformatted tape cartridges. Data integrity features include automatic read retries initiated by the controller to ensure accurate data recording and retrieval. This feature eliminates the host computer overhead normally associated with rereading soft errors. Each transport has a high-quality read/write head. The TU58 can be used for software updates or for loading diagnostics or as a convenient medium for private file storage. These subsystems consist of a controller, two drives, universal power cords, boot chip, 5.5 m (18 ft) of I/O cable to interface with a serial line unit (which is a prerequisite), and two TU58-K media.

## Performance Specifications:

- Recording density: 800 b/in
- Read/write speed: 30 in/s
- Capacity per cartridge: 256 KB  
(formatted in 512 blocks of 512 bytes each)
- Maximum data transfer speed: 3.7 KB/s (38.4 Kbaud)
- Rewind speed: 60 in/s
- Rewind time: 30 seconds per 140 ft cartridge

## Ordering Information:

- |                |  |
|----------------|--|
| <b>TU58-DA</b> | Cabinet-mountable dual-drive cartridge tape subsystem including the necessary hardware for mounting in standard cabinetry. |
| <b>TU58-EB</b> | Tabletop dual-drive cartridge tape subsystem.  |

## Site Preparation Specifications:

- Height: 13.3 cm (5.25 in)
- Width: 48.3 cm (19 in)
- Depth: 43.2 cm (17 in)
- Weight: 9 kg (20 lb)
- Watts: 11
- Btu/hr: 38
- Receptacles:  
NEMA #5-15R (120VAC/60Hz),  
NEMA #6-15R (240VAC/50Hz)

# Configuring Information

## UNIBUS Magnetic Tapes

Model	Mounting Code	DC Amps Drawn @ +5V/-15V	Bus Loads Drawn	Panel Units
TJE16	2 SUs	12.0/0.4	1	1
TJU77	2 SUs	12.0/0.4	1	1
TU80	1 Slot	4.0/0.0	1	1

## Q-bus Magnetic Tapes

Model	Mounting Code	DC Amps Drawn @ +5V/+12V	Bus Loads (AC/DC)	Panel Inserts
TSV05	1 Quad Slot	6.5/0	3/1	2 Size A

Disks and Tapes

## Magnetic Tape Site Preparation

Model	Height	Width	Depth	Watts	BTU/hr	Weight
TJE16 In Cabinet	152.4 cm 60 in	71 cm 28 in	76.2 cm 30 in	900	3100	227 kg 500 lbs
TJU77 In Cabinet	152.4 cm 60 in	71 cm 28 in	76.2 cm 30 in	2250	7690	254 kg 560 lbs
TSV05 In Cabinet	111.1 cm 43.75 in	60 cm 23.5 in	84 cm 33 in	270	1100	121 kg 265 lbs
TSV05 Rackmount	22.2 cm 8.75 in	43 cm 17 in	62 cm 24.5 in	270	1100	36 kg 80 lbs
TU58 Rackmount	13.3 cm 5.25 in	48.3 cm 19 in	43.2 cm 17 in	11	38	9 kg 20 lbs
TU80 In Cabinet	105.7 cm 41.6 in	54 cm 30 in	54.6 cm 21.5 in	500	1024	102.5 kg 225 lbs



# 5 Digital's Personal Computers

---

Attractively styled and designed for efficient and comfortable operation, each of Digital's personal computers—Rainbow 100, DECmate II, and the Professional 325/350—specializes in a particular class of applications software. These range from industry-standard CP/M personal computing software up to sophisticated applications developed on a powerful minicomputer operating system. Because Digital's personal computers can run a wide variety of software, they can address a complete range of personal computing needs.

Digital's personal computers provide three distinct software environments for applications:

- Rainbow 100 — 8- and 16-bit-based CP/M-86/80 software designed for popular industry-standard personal computer applications.
- DECmate II — 12-bit-based WPS-8 and COS-310 software featuring Digital's proven word processing, office management, and accounting applications.
- Professional 300 Series— 16-bit-based multitasking Professional Operating System (P/OS) especially developed for powerful professional applications.



## Common Hardware Components

Digital's personal computers can run a wide range of software with a minimum of hardware variations. All three personal computer series have the same keyboard and monitor, along with the diskette drive, optional hard disk, printers, and other major components. The primary differences between these personal computers is the computer's system board, and thus the type of software they support. A minimum working hardware configuration consists of a country kit with keyboard and documentation, a system unit, and a monitor.

The common components utilized by the personal computer series are:

- **Monitor**—30.5 cm (12 in) monochrome or 33 cm (13 in) color display featuring 24-lines-by-an 80- or 132-character column width and bonded, antiglare screen.
- **Keyboard**—105-key low-profile keyboard with 1.9 m (6 ft) coiled cable. Rainbow 100, DECmate II, and the Professional series use keyboards with country-specific keycap legends.
- **System unit**—Computer cabinet containing the system board, power supply, option slots, and storage devices. There are two system units: a small box for the Rainbow 100 and DECmate II, and a large-box version for the Professional 325 and 350.
- **Diskette drive**—5 ¼-inch dual-floppy diskette drive with 800 Kbytes of online storage contained on two diskettes (400 Kbytes each).
- **Hard-disk drive**—5 ¼-inch hard-disk drive with a ten-MB storage capacity.
- **Floorstand**—Optional vertical stand for mounting the system unit on the floor next to your desk in order to free more desktop space.
- **Printers**—A choice of three optional printers for all of Digital's personal computers: the LA50 Personal Printer, the Letterprinter 100, and the LQPO2 Letter-Quality Printer.

## Ordering Process

Ordering Digital's personal computers is simple and straightforward. A basic working system consists of a country kit, monitor, system unit, and system software. The system unit includes the system board, which contains logic, memory, and communication circuitry for that particular personal computer. You simply order each of the major components separately in order to make up a working system. Hardware and software options that correspond to each of the personal computers are ordered in the same fashion.

The country kit consists of a keyboard, system power cable, and documentation kit corresponding to a specific country. Country kits for the Rainbow 100 also contain a national language read-only memory (ROM) adapter that is customer-installable in the system unit. System units come standard with English-language ROMs.

## Configuring Overview

Configuring Digital's personal computers is just as easy as ordering them. There are very few rules to follow, and all standard and optional components are designed for easy installation and removal. The system unit, for example, features a slide-out mechanism for the system board and diskette/hard-disk drives. These same components are installed by sliding them along a rail until they snap in place. Similarly, the system unit cover and power supply are removed by releasing tabs and lifting them up from the system unit chassis.

Depending on the personal computer, option modules are slide-mounted into slots or snapped onto the system board. The Professional 325 and 350 have an option-module cage located on the rear portion of the system board. Modules are installed by sliding them in lengthwise along rails, from an opening on the right side of the system unit chassis, and are secured by a locking lever. Module cables plug into slots located along the top of each module. Option modules for the Rainbow 100 and DECmate II plug into designated locations on the system board.

All of Digital's personal computers feature a built-in serial printer port and RS232-C communications port in the back of the system unit. These ports simplify printer and communication line hook-up. In addition, the universal power supply for Digital's personal computers feature a switch-selectable 115- or 230- V setting for international operation.

# Rainbow 100 Personal Computer

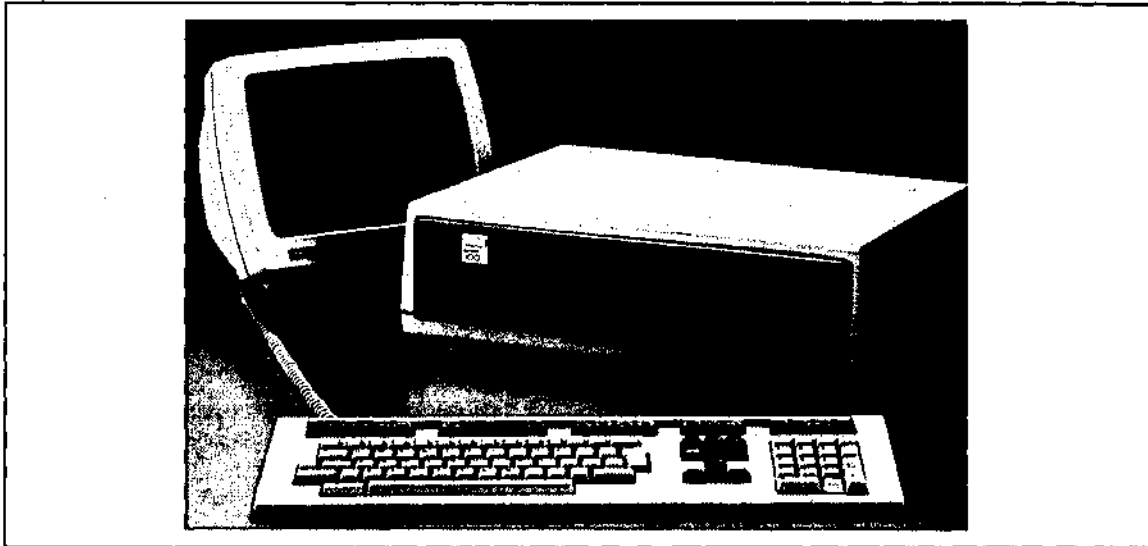

Rainbow's superb design--inside and out--will help you be more productive and will make your job easier. It is a price/performance leader capable of running the widest possible selection of industry-standard CP/M applications. You can run both mature 8-bit software and today's advanced 16-bit programs without swapping system disks or even telling your personal computer which kind of program you've loaded--Rainbow's "softsense" automatically knows which it is.

The Rainbow 100 base system is a complete solution. It comes standard with 8-bit and 16-bit microprocessors, 800 Kbytes of diskette space on a single drive, and enough memory to get real work done from the start. The communications port allows you to take full advantage of Rainbow's communication capabilities. It can talk to another personal computer, interactively to a host or information network (giving you dial-in access to public information systems like Dow Jones/Retrieval and The Source), or as a terminal to a host. Its built-in full VT102 terminal emulation capability gives you a personal computer and a terminal rolled into one.

The printer port is also standard. Advanced features like memory-mapped video--which repaints your screen very fast as you work--give you really high performance. Rainbow's 132-column display capability, especially important for financial spreadsheet applications, lets you see more information at one time on the screen.

With Rainbow's self-teaching CBI (computer-based instruction) course, "Learn Rainbow", you can learn how to use your Rainbow 100 personal computer in as little as 90 minutes. The course is designed in modules so you can learn at your own pace and review at any time in the future any sections you wish.

## Expansion

There are three dedicated option slots for system expansion on the system board, so you can add more memory, bit-mapped graphics, and extended communications capability to your Rainbow. The dedicated memory slot accommodates either a 64 KB or 192 KB memory module option for a total of 128 or 256 Kbytes of main memory. You can easily install all of the expansion modules in the system unit yourself without any special tools.

You can also add an additional dual-diskette drive to your system. It slides right into the system unit, with just two simple connections to be made.

## Ordering Information

<b>QVO12-A3</b>	CP/M-86/80 operating system
<b>VR201-A</b>	12 in monochrome monitor; white phosphor
<b>VR201-B</b>	12 in monochrome monitor; green phosphor
<b>VR201-C</b>	12 in monochrome monitor; amber phosphor
<b>PC100-A</b>	Rainbow 100 system unit

# Rainbow 100 Personal Computer

## Rainbow 100 Hardware

<b>PC1K1-Ax</b>	<b>Country Kit.</b> Contains country-specific keyboard, keyboard cable, and power cord. In addition, user documentation in the appropriate national language is also included. <b>Note:</b> Keyboards with corresponding keyboard cable and power cord may be ordered using option number LK201-xx, where xx indicates the specific country code.
<b>PC1K1-AA</b>	USA-Canada
<b>PC1K1-AC</b>	Canada (French)
<b>PC1K1-AE</b>	UK
<b>PC1K1-AG</b>	Germany
<b>PC1K1-AI</b>	Italy
<b>PC1K1-AK</b>	Switzerland (French)
<b>PC1K1-AL</b>	Switzerland (German)
<b>PC1K1-AP</b>	France
<b>PC1K1-AS</b>	Spain
<b>PC1K1-AZ</b>	Australia
<b>PC1XX-AA</b>	<b>64-KB RAM module.</b> Option module expands system memory to 128 KB. This module mounts in a dedicated memory slot on the system board and is user-installable.
<b>PC1XX-AB</b>	<b>192-KB RAM module.</b> Option module expands system memory to 256 Kbytes. This module mounts in a dedicated memory slot on the system board and is user-installable.
<b>RX50-XA</b>	<b>Dual-diskette drive.</b> 5¼ inch (13.34 cm) dual-diskette drive provides additional 800 KB of online storage on two 400 KB formatted diskettes. When added to the Rainbow 100 personal computer, total online storage capacity is increased to 1.6 Mbytes. Drive unit utilizes two double-density diskettes rotated by a single spindle.
<b>PC1XX-BA</b>	<b>Graphics module.</b> Provides easy-to-use high-level command language that draws figures from simple vectors up to complex open and closed curves. The graphics module provides bit-mapped color displays in two resolution modes: 800 x 240 picture elements (pixels) with two planes and four colors, or 384 x 240 pixels with 4 colors and 16 colors. Complete documentation and installation instructions are provided for this option. <b>Note:</b> The graphics module supports the 13 inch color monitor (VR241-A).
<b>PC1XX-BB</b>	<b>Extended communications module.</b> Extends the capabilities of Rainbow 100 by providing a communications port for DMA asynchronous and byte or bit synchronous communications, and an RS423 800-kilobit/sec port for high-throughput external devices that can be under program control. The extended communications module is required for the RCD50 Winchester disk storage option. Complete documentation and installation instructions are provided for this option.
<b>RCD51-BA</b>	<b>Hard-disk subsystem.</b> Ten-MB, 5¼-inch hard disk drive and controller provides additional internal storage to the 800 KB of diskette storage available inside the Professional 350's system unit. This compact, high-performance disk subsystem features a five million bit/second transfer rate and an average access time of 85 milliseconds. Controller module occupies one option slot.
<b>PCXXF-BA</b>	<b>Floorstand unit for PC100.</b> Enclosure for vertical mounting of the Rainbow 100 system unit. Provides a stable platform when system unit is removed from work surface and placed on the floor. Raised pedestal base also provides adequate room for power supply cooling fans.
<b>VR241-A,-B,-C</b>	<b>Color Monitor.</b> The high-bandwidth color monitor allows display of either full 80 or 132 column text by 24 row text characters, or 800 by 240 bit-mapped graphics. These precise color graphics are displayable in two modes of either 4 or 16 colors, selectable from an extensive palette. Requires Rainbow's graphic options module (PC1XX-BA).

**Note:** See the Personal Computer Catalog for a complete guide to Personal Computing Software.



# DECmate II Personal Computer

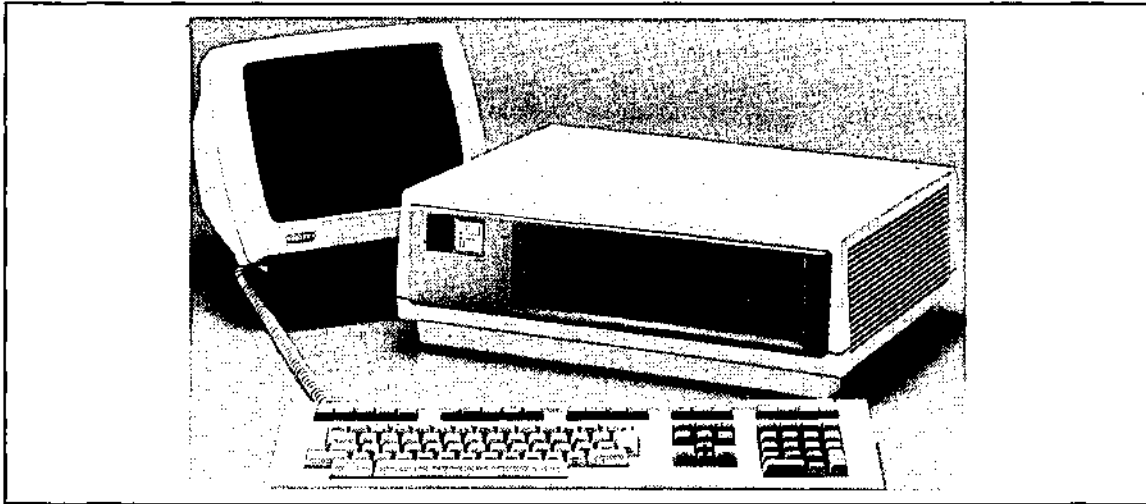

## DECmate II

The low-cost DECmate II has been tailored to meet the needs of offices and small businesses. As a small business specialist, DECmate II offers proven word processing, office management, and accounting applications. Its features enhanced word processing capabilities with optional software such as Sort, List Processing, Math, and Communications. In addition, an optional auxiliary processor supports Digital's CP/M-80 software for personal computing. This auxiliary processor also supports such business applications as Digital's Accounting System (DAS), a family of integrated accounting packages. In short, DECmate II has been optimized for small business applications, offering a complete "turn key" business solution.

DECmate II's professional-quality word processing, sorting, list processing, and communications are equally well-suited for offices. Spreadsheet calculator applications quickly project and manipulate results of financial, sales, and manufacturing forecasts that require frequent analysis. Moreover, DECmate II's communications capabilities let users access files and software of host computers that serve entire departments. Its terminal emulation capability makes DECmate II appear to a host as a VT100-family terminal. This capability enables offices throughout an organization to run an assortment of sophisticated, menu-driven office applications that reside on host systems—in addition to those available on DECmate II. DECmate II can also transfer files to and from other DECmate II personal computers by using its document and character file transfer capabilities.

The DECmate II system unit includes:

- DEC 6120 (PDP-8) 12-bit microprocessor
- 96 KB memory (64 Kwords)
- RS232-C serial printer port
- Asynchronous/byte synchronous communications port, to 9600 baud with full modem control
- Monochrome character cell video output
- Built-in diagnostic firmware
- Switch-selectable (115 V or 230 V) universal power supply
- 5 1/4-inch 800 KB dual-diskette drive and controller

### Ordering Information:

In order to have a working DECmate II personal computer system, you need to have the following components and one of the operating systems:

<b>PC27X-AA</b>	CP/M-80 operating system
<b>VR201-A</b>	12-inch monochrome monitor; white phosphor
<b>VR201-B</b>	12-inch monochrome monitor; green phosphor
<b>VR201-C</b>	12-inch monochrome monitor; amber phosphor
<b>PC2K1-Ax</b>	Country Kit
<b>PC278-A</b>	DECmate II system unit
<b>QF740-A3</b>	Word Processing base operating system
<b>QF310-A3</b>	COS-310 operating system

# DECmate II Personal Computer

## System Expansion

There are three dedicated slots for customer-installable option modules on the system board.

## Memory Expansion

DECmate II systems come with a standard maximum memory size of 96 Kbytes. **Note:** The optional CP/M module contains a Z80 microprocessor and 64 Kbytes of memory for use with CP/M applications.

## Mass Storage Expansion

A second 800 KB RX50 dual-diskette subsystem can be installed internally in the system unit for 1.6 MB of online diskette storage. An optional 10 MB hard-disk drive, mounting where the second diskette drive would normally be placed, can also be added internally for a maximum total of 10.8 MB of online storage.

## DECmate II Hardware

<b>PC2K1-Ax</b>	<b>Country Kit.</b> Contains country-specific keyboard, keyboard cable, and power cord. In addition, user documentation in the appropriate national language is included. <b>Note:</b> Keyboards with corresponding keyboard cable and power cord may be ordered using option number LK201-Bx, where x indicates the specific country code (e.g., A for USA-Canada, P for France).  PC2K1-AA USA PC2K1-AE UK PC2K1-AZ Australia PC2K1-AQ Canada (English-speaking)
<b>PC27X-AA</b>	<b>CP/M Module.</b> Contains a Z80 auxiliary processor unit, 64 Kbytes of memory, and an interface to the 6120 processor for use with CP/M applications. This option allows the user to run 8-bit CP/M applications in addition to DECmate II's 12-bit software. The 8-MHz 6120 processor performs all I/O tasks for the 4-MHz Z80 auxiliary processor, resulting in a significant performance advantage when running CP/M applications. The CP/M module mounts in a dedicated slot on the system board and includes the CP/M-80 operating system, license, and user documentation.
<b>PC27X-BA</b>	<b>RX01/RX02 Interface module.</b> Interfaces Digital's eight-inch RX01 and RX02 diskette drives to DECmate II systems. Owners of DECmate I systems can use existing media with DECmate II, or can transfer their files from eight-inch 500 Kbyte diskettes to 5 1/4-inch 400-Kbyte mini-diskettes. This file and drive compatibility ensures smooth system migration. The interface module mounts in a slot dedicated to mass storage and comes with an adapter cable for the RX01/RX02 disk drive.
<b>RX50-XA</b>	<b>Dual-diskette drive.</b> 5 1/4-inch dual-diskette drive provides additional 800 Kbytes of online storage on two 400-KB formatted diskettes. When added to DECmate II personal computers, total online storage capacity is increased to 1.6-Mbytes. Drive unit utilizes two double-density diskettes rotated by a single spindle.
<b>RCDS1-CA</b>	<b>Hard-disk drive.</b> 10 MB 5 1/4-inch hard disk drive provides additional internal storage to the 800 Kbytes of diskette storage available inside DECmate II's system unit. This compact high-performance disk subsystem based on Winchester technology features a five million bit-per-second transfer rate and an average access time of 85 milliseconds. The hard disk drive subsystem includes the hard disk interface module for operation.
<b>PCXXF-BA</b>	<b>Floorstand unit for PC278-A.</b> Enclosure for vertical mounting of the DECmate II system unit. Provides a stable platform when system unit is placed on the floor. Raised pedestal base also provides adequate room for power supply cooling fans.

# DECmate II Personal Computer

---

## DECmate II Software

- QF740-A3**      **WPS Operating System.** Base-level operating system consisting of DECmate II Version 1.0 word processing software. WPS contains advanced word processing capabilities and features. These include a go-to-page command that eliminates unnecessary scrolling; global search and replace for automatically inserting new information; automatic pagination command that paginates an entire document on the screen; and wide-ruler support for displaying 132-character lines. In addition, optional WPS software packages allow DECmate II systems to function as a stand-alone, multipurpose word processor/office management system.
- QF741-A3**      **WPS List Processing Package.** Allows the user to generate personalized form letters and other documents with slightly altered text. A form letter with blanks for key information is merged with a list document that contains the corresponding information for the letter's blanks. Each record in the list document file contains the information to produce one customized version of the form document. The list document file can contain up to 4,000 records, each holding a maximum of 2,500 characters. The List Processing enhancement package requires the WPS operating system.
- QF742-A3**      **WPS Sort Package.** Enables the user to sort up to 12 different fields of information in a List Processing document. Alphanumeric information can be organized in either ascending or descending order. The user can also sort numbers with positive and negative values, decimal points, dollar signs, and other symbols. The Sort enhancement package requires the WPS operating system.
- QF743-A3**      **WPS Communications Package.** Adds terminal emulation and file transfer capability to DECmate II. DECmate II will emulate a VT52 or VT102 video terminal through local or remote lines using this software. In addition, file transfer software allows DECmate II to communicate with other DECmate systems, with a host computer, or with phototypesetters. Three modes of file transfer are supported: DX (document transmission) mode that transmits and receives complete word processing documents; AX (automatic transmission) mode that transmits or receives complete documents without operator intervention; and CX (character transmission) mode that communicates interactively with host systems and applications. The Communications enhancement package requires the WPS operating system.
- QF744-A3**      **WPS Math Package.** Creates, updates, and maintains numerical tables with column totals, subtotals, and averages. Editor math function can be used to repeat calculations and update tables if entries in a document's table change. The List Processing portion of this package does calculations based on mathematical statements that are embedded in a list processing document and inserts the answers into the output documents. List Processing math enables the user to create a variety of output documents by varying specification documents. The Math enhancement package requires the WPS operating system.
- QF745-A3**      **WPS Complete Package.** Contains WPS operating system and the List Processing, Sort, Communications, and Math packages.
- QF310-A3**      **COS-310 Operating System.** Version 9.2 of the commercial operating system developed by Digital. Enhancements include support for the RX50 diskette drive and LA100 printer, in addition to various refinements. DIBOL-8 and DIBOL-11 are included with COS-310. COS-310 will accommodate user-developed application packages and will also run selected applications currently available on RX02 diskette media.
- QF310-C3**      **COS-310 License only.** License-only version of COS-310 operating system.

**Note:** See the Personal Computer Catalog for a complete guide to Personal Computing Software.

# Professional 325 and 350 Personal Computers

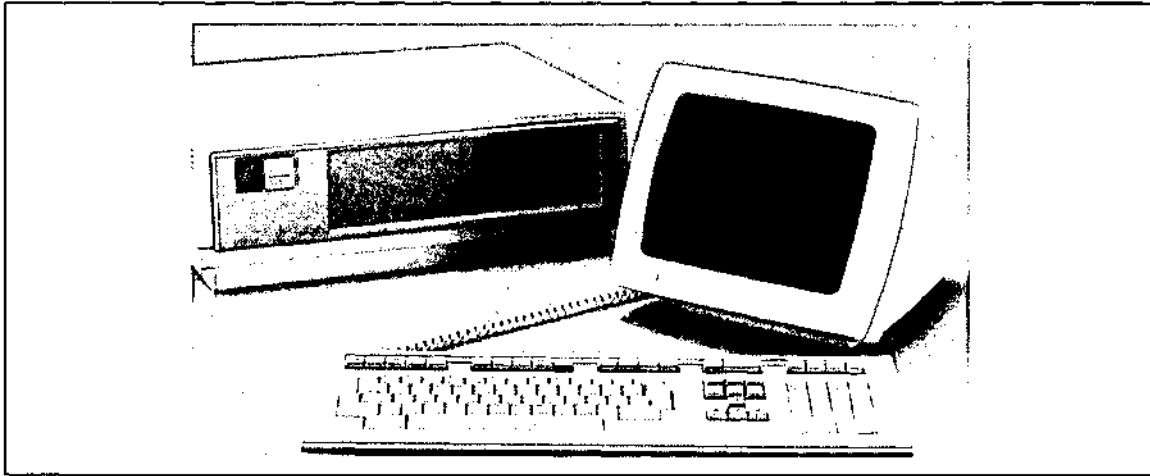

## The Professional 300 Series

The powerful Professional 325 and 350 bring minicomputer performance to the world of personal computing. Utilizing a 16-bit PDP-11/23-PLUS microprocessor, the Professionals feature a multitasking operating system based on RSX-11M-PLUS, Digital's popular PDP-11 operating system.

The Professional Operating System (P/OS) has sophisticated communications capabilities. It shares a common file structure with Digital's PDP-11 and VAX minicomputers, giving the Professionals extensive file transfer and data sharing capabilities.

Many ease-of-use features have been incorporated into the multitasking P/OS. A "menu tree" provides common, integrated menus for many system functions, including disk services, file services, print services, communications, and editing. P/OS also includes an online help function for obtaining information on system services and applications, and a "message board" where programs can display status information. Like DECmate II, the Professional 325 and 350 support an optional auxiliary processor and memory for CP/M-80 applications.

Digital offers both P/OS and CP/M-80 applications for business and educational needs. Applications may also be purchased from software developers and vendors. The optional program developer's Tool Kit, containing high-level software tools, is available for those who wish to write applications compatible and consistent with the P/OS environment.

The Professional 325 and 350 system units both include:

- PDP-11/23-PLUS 16-bit microprocessor
- Memory management unit
- 512 KB memory
- Time-of-day clock with battery back-up
- Bit-mapped video controller (960 x 240 pixels)
- RS232-C serial printer port
- Asynchronous and bit or byte synchronous communications port, up to 9600 baud with full modem control
- RS170-compatible, monochrome bit-mapped video output
- Built-in diagnostic firmware with graphics display
- Switch-selectable (115 V or 230 V) universal power supply
- 5 1/4-inch, (13.34 cm) 800 KB dual-diskette drive and controller
- Standard Floating Point Adapter provides up to 17 digits of precision

## Ordering Information:

In order to have a working Professional 300 Series personal computer system, you need to have the following components:

<b>PC3K1-Ax</b>	Country Kit including the Professional Operating System
<b>VR201-A</b>	30.44 cm (12 in) monochrome monitor
<b>PC325-D</b>	Professional 325 system unit
<b>PC350-D</b>	Professional 350 system unit

# Professional 325 & 350 Personal Computer

---

## System Expansion

There is one slot available for a customer-installable option module on the Professional 325's system board. The Professional 350 accommodates four option modules. A Professional 325 can be upgraded to a Professional 350 by installing a Professional 350 system board.

## Memory Expansion

With the Professional 350, up to one MB of memory can be added in increments of 256 KB. Each 256 KB memory option occupies one option slot.

## Mass Storage Expansion

Professional 325 and 350 system units are fully configured with an 800-KB RX50 diskette drive. In addition to the RX50 diskette drive, the Professional 350 system unit accommodates the five-Mbyte or the ten-Mbyte hard-disk option.

## Professional Hardware

**PC3K1-AX**                    **Country Kit.** Contains country-specific keyboard, keyboard cable, and power cord. A computer-based instruction diskette, hardware exerciser, editor and operating system software, and user documentation are also included.

**Note:** Keyboards with corresponding keyboard cable and power cord may be ordered using option number LK201-XX, where XX indicates the specific country code.

<b>PC3K1-AA</b>	USA
<b>PC3K1-AC</b>	Canada (French)
<b>PC3K1-AD</b>	Denmark
<b>PC3K1-AE</b>	UK
<b>PC3K1-AF</b>	Finland
<b>PC3K1-AG</b>	Germany
<b>PC3K1-AI</b>	Italy
<b>PC3K1-AK</b>	Switzerland (French)
<b>PC3K1-AL</b>	Switzerland (German)
<b>PC3K1-AM</b>	Sweden
<b>PC3K1-AN</b>	Norway
<b>PC3K1-AP</b>	France
<b>PC3K1-AS</b>	Spain
<b>PC3K1-AZ</b>	Australia
<b>PC3K1-AB</b>	Belgium (Flemish)
<b>PC3K1-AH</b>	Netherlands
<b>PC3K1-AQ</b>	Canada (English)

# Professional 325 & 350 Personal Computer

<b>MSC11-CK</b>	<p><b>256-KB Memory Option.</b> Provides 256-KB of additional MOS memory for the Professional 350, increasing total memory size to a maximum of 1 MB in 256 KB increments. Adding additional memory to your personal computer increases its overall system performance, since larger programs can reside in memory.</p> <p>Each memory option utilizes one option slot.</p>
<b>PC3XS-AA</b>	<p><b>CP/M Option.</b> Contains a Z80 auxiliary processor unit, 64 KB of memory, and an interface to the Professional's processor for use with CP/M applications. This option allows the user to run 8-bit CP/M applications in addition to P/OS 16-bit software.</p> <p>The CP/M option module requires one option slot and includes the CP/M-80 operating system, license, and user documentation.</p>
<b>RCD50-AA</b>	<p><b>Hard-disk subsystem.</b> Five-Mbyte, 5¼-inch hard disk drive and controller provides additional internal storage to the 800 KB of diskette storage available inside the Professional 350's system unit. This compact, high-performance disk subsystem features a five million bit/second transfer rate and an average access time of 170 milliseconds.</p> <p>Controller module occupies an option slot.</p> <p><b>Note:</b> The hard disk-based P/OS and associated documentation is included with the RCD50-AA.</p>
<b>RCD51-AA</b>	<p><b>Hard-disk subsystem.</b> Ten-Mbyte, 5¼-inch hard disk drive and controller provides additional internal storage to the 800 KB of diskette storage available inside the Professional 350's system unit. This compact, high-performance disk subsystem features a five million bit/second transfer rate and an average access time of 85 milliseconds.</p> <p>Controller module occupies an option slot.</p> <p><b>Note:</b> The hard disk-based P/OS and associated documentation is included with the RCD51-AA.</p>
<b>VC241-A</b>	<p><b>Extended bit-map module.</b> Adds two bit-map planes to the standard video generator for a total of three planes. Each plane supports a display of 960 x 240 pixels. In addition, the extended bit-map option adds a color output map that can simultaneously display on a color monitor eight colors from a palette of 256 colors. Displays eight of a possible 16 shades of gray on the monochrome monitor.</p> <p>Occupies one option slot.</p> <p><b>Note:</b> The extended bit map module supports the 13-inch (33.02) color monitor (VR241).</p>
<b>DTC11-A</b>	<p><b>Telephone management option.</b> Provides integrated telephone management capabilities. With the Professional Communications Software package, TMS supports autodialing for hands-free calling. In addition, TMS can transfer files to RSX and VMS systems from the same directory using an integral modem with BELL 103J, 202, and 212A compatible modes. Hardware consists of a TMS controller module, a telephone line interface, and an optional voice unit. Controller includes voice digitization (CODEC) and dual-tone multifrequency (DTMF) encoding circuitry for hardware support of dictation, telephone answering, voice messaging, and remote commands. Telephone interface panel provides jacks for two telephone lines (one for data and one for voice communications), a local telephone handset, and the optional voice unit.</p> <p>The telephone management option module occupies one option slot, while the interface panel mounts in a designated location in back of the system unit.</p> <p><b>Prerequisite:</b> Professional Communications Software package (QB005-C3).</p>
<b>DTC11-B</b>	<p><b>Voice unit.</b> Provides a microphone and speaker for voice input and output, a telephone dialpad, and nine command keys with associated LEDs. The voice unit is ideal for teleconferences and hands-free telephone operation. In addition, an audio jack accommodates a headset for use when conducting telemarketing operations. Voice unit features same ergonomic design used by the keyboard.</p> <p><b>Prerequisite:</b> Telephone Management Option and Professional Communications Software package (QB005-C3).</p>
<b>IDLDR-CA</b>	<p><b>Realtime interface.</b> I/O interface combines three widely used realtime functions on a single module for scientific/engineering applications. Includes an IEEE-488 (1978) general purpose instrument bus for control of up to 15 compatible devices: a two-line RS232-C RS232-C/423-compatible serial asynchronous port with user-selectable baud rates (50 to 9600 baud); and a 24-line parallel port with 16 data lines and 8 control lines. IEEE and serial interface allows the Professional to control and acquire data from external devices such as analytical instruments and automatic test equipment. Parallel interface enables users to acquire binary coded decimal inputs. All three interfaces can be used with compatible third-party products to provide analog input/output.</p>
<b>PCXXF-AA</b>	<p><b>Floorstand unit for PC350-D.</b> Enclosure for vertical mounting of the Professional 350 system unit. Provides a stable platform when system unit is removed from work surface and placed on the floor. Raised pedestal base also provides adequate room for power supply cooling fans.</p>
<b>PCXXF-BA</b>	<p><b>Floorstand unit for PC325-D.</b> Same as above PCXXF-AA, except for mounting of the Professional 325 system unit</p>

# Professional 325 & 350 Personal Computer

---

## Professional Software

**QB005-C3**      **PRO/Communications.** Adds terminal emulation and file transfer to the Professional Series. In addition, adds TMS support to the Professional 325 and 350. Terminal emulation mode allows the Professionals to operate as a VT102 or VT125 terminal. The Extended Bit-Map module is required for VT125 emulation. Files can be transferred to and from the Professional by invoking a file transfer task on the host (terminal emulation mode) or by utilizing the file transfer utility in the communications package. The file transfer utility supports active or passive modes of file transfer to and from other Professionals and host computers. In addition, the Professional Communications Package allows selection of various line characteristics that can be set for each different computer or phone number. Line characteristics are stored in the Professional Phone Book along with a directory of names and phone numbers. Supports autodialing using TMS or a DF03 modem.

**Note:** Optional communications software must be installed on VAX/VMS, RSX-11M, RSX-11M-PLUS, or P/OS-based systems for file transfer. Requires modem or RS232-C cable to a host computer or another Professional.

**QBE11-C3**  
**QBE12-C3**      **PROSE-PLUS.** PROSE-PLUS is an enhanced version of PROSE, the full screen text editor, (included in the Professional operating system), designed in conjunction with the Professional 300 series keyboard. PROSE-PLUS provides word processing capability layered on the P/OS and uses the P/OS services for menus and help. It uses RMS sequential files for its permanent files. Text in the process of being edited is kept in a temporary work file. PROSE-PLUS maintains file compatibility with the PROSE editor, but does not maintain file compatibility with other Digital word processing systems. It has some powerful text attributes and embedded control capabilities that allow the user to do such functions as uppercase, lowercase, bold, underline, new page, conditional page, center line, text formatting and rulers. Additionally, it has other word processing capabilities like search and replace functions, and editor functions such as date and time, paginate, and rewrap selected text. **Note:**The QBE11-C3 is the PROSE-PLUS/DISKETTE. The QBE12-C3 is the PROSE-PLUS/HARD DISK.

**Note:** For additional application software refer to the Personal Computer Catalog.

# Professional 325 & 350 Personal Computer

## Professional Host Tool Kit Ordering Information (RSX-11M/M-PLUS Host)

- QJ071-xx\*** **Professional Host Tool Kit.** Contains software and optional hardware for developing Professional applications compatible with the P/OS menu-driven environment. Utilizes a host system running RSX-11M, RSX11M-PLUS, or VAX/VMS. Decreases program development costs by preserving hardware and software investments, by increasing programmer productivity through use of powerful development tools, and by reducing training requirements that are associated with learning a new system. Includes Professional MACRO-11 Assembler. In addition, the Tool Kit includes PRO/RMS for record access; PRO/FMS for forms-oriented video I/O management; PRO/SORT for record sort; the CORE Graphics Library for over 20 device-independent graphics commands; the Professional Diskette Builder for end-user media distribution. Applications are developed on the host system and are transferred to the Professional 350 for debugging.  
**Support Category**—Digital Supported/Customer Installed  
**License**—Single-use license, binaries, documentation, and support services
- QJ074-xx\*** **Professional Host Tool Kit FORTRAN-77.** High-performance, optimizing FORTRAN compiler for use with the Professional Host Tool Kit.  
**Support Category**—Digital Supported/Customer Installed  
**License**—Single-use license, binaries, documentation, and support services
- QJ073-xx\*** **Professional Host Tool Kit BASIC-PLUS-2.** Optimizing BASIC compiler for use with the Professional Host Tool Kit. See description for PDP-11 BASIC-PLUS-2.  
**Support Category**—Digital Supported/Customer Installed  
**License**—Single-use license, binaries, documentation, and support services
- QJ369-xx\*** **Professional Host Tool Kit DIBOL.** Professional Host Tool Kit DIBOL is a complete software package that enables the user to develop Professional 300 applications using the DIBOL programming language. It is compatible with the other DIBOL offerings (source level) and it permits an easy migration path from the smallest Professional 300 computer to the largest systems. This compatibility is very important when considering the increasing number of clients who combine VAX-11 and PDP-11 systems to fulfill their data processing requirements.  
**Support Category**—Digital Supported/Customer Installed  
**License**—Single-use license, binaries, documentation, and support services
- QJ081-xx\*** **Professional Host Tool Kit Cobol-81.** Professional Host Tool Kit Cobol-81 is a high-level language for business data processing that generates programs for execution under control of the P/OS Operating System. It is based on the 1974 ANSI COBOL Standard x3.23-1974 and includes some of the features planned for the next COBOL standard. The COBOL-81 is compatible with COBOL-81/RSX and includes various DIGITAL extensions to COBOL, including screen handling at the source language level.  
**Support Category**—Digital Supported/Customer Installed  
**License**—Single-use license, binaries, documentation, and support services
- QJ082-xx\*** **Professional Host Tool Kit Pascal.** Professional Host Tool Kit Pascal is an extended implementation of the PASCAL language. The extensions assist the programmer in accessing the P/OS system capabilities and simplify application design. In addition, there is a high degree of compatibility with VAX-11 PASCAL and the ISO and ANSI Pascal standards.  
**Support Category**—Digital Supported/Customer Installed  
**License**—Single-use license, binaries, documentation, and support services
- QX351-xx\*** **Host File Transfer Package.** Complementary communications package for VAX/VMS and PDP-11 RSX-11M host systems. Transfers files to and from the Professional 325 and 350. The PRO/Communications Package must be installed on the Professional for complete communications capability.  
**Support Category**—Digital Supported/Customer Installed  
**License**—Single-use license, binaries, documentation, and support services

**Note:** The Professional Host Tool Kits are also available for VAX systems. However, this ordering information is not included in this catalog.



# Professional 325 & 350 Personal Computer

---

## Order Code Suffixes

The following suffixes replace the "xx" in the Professional Host Tool Kit order numbers above. These suffixes designate the license agreement (and support arrangements) and the distribution media (or right to copy) as follows:

<b>-AD</b>	Single-use license, binaries on 800 BPI magtape, documentation, and support services
<b>-AH</b>	Single-use license, binaries on RL02 disk cartridge, documentation, and support services
<b>-AM</b>	Single-use license, binaries on 1600 BPI magtape, documentation, and support services
<b>-AG</b>	Single-use license, binaries on TU58 cassette tape, documentation, and support services
<b>-HD</b>	Update license, documentation, and no support services; 800 BPI magtape
<b>-HH</b>	Update license, documentation, and no support services; RL02 disk cartridge
<b>-HM</b>	Update license, documentation, and no support services; 1600 BPI magtape
<b>-HG</b>	Update license, documentation, and no support services; TU58 cassette tape

# Personal Computers Catalog

---

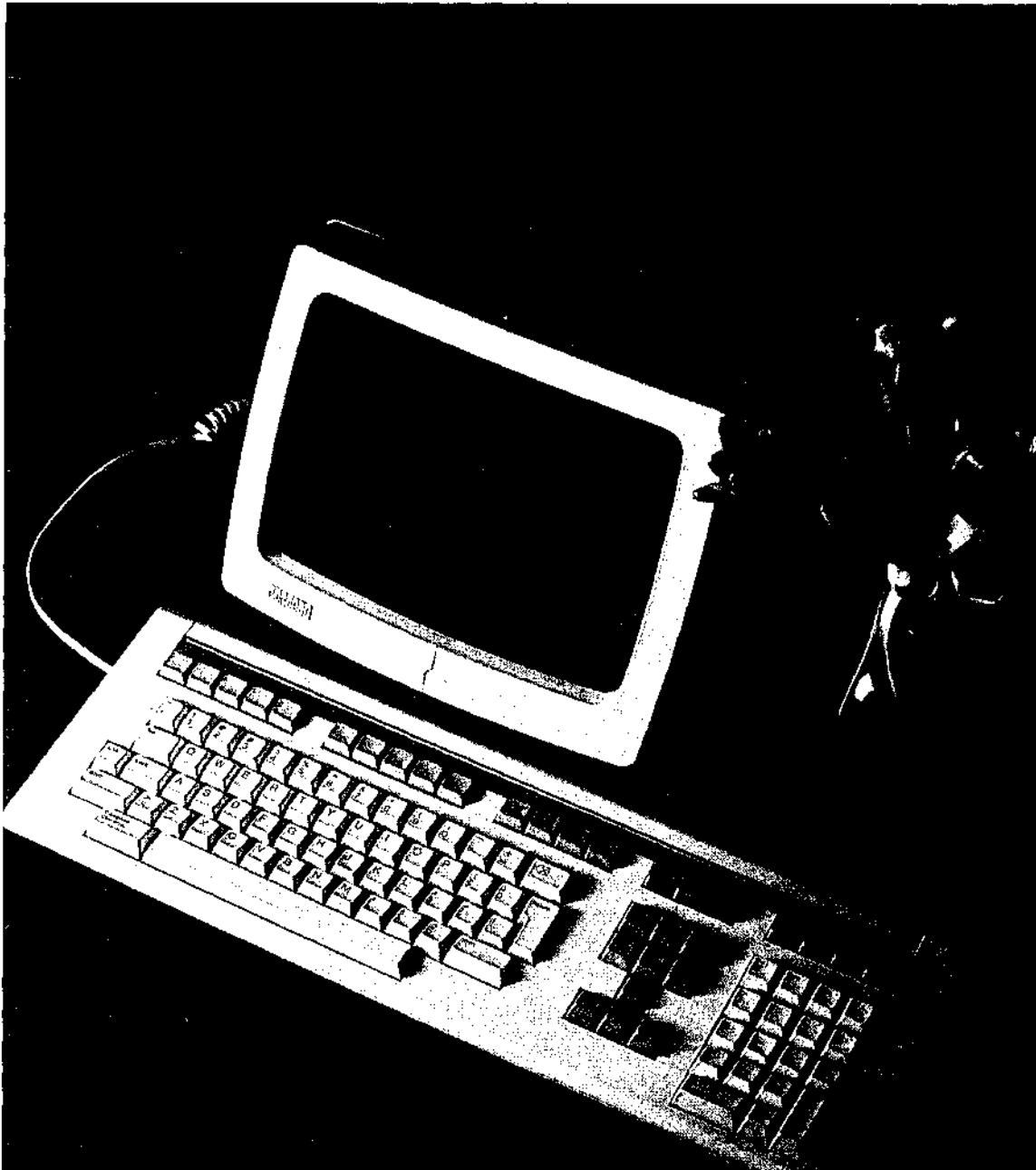

Personal  
Computers

The new Personal Computers Catalog contains descriptions of the software packages available for Digital's Personal Computers. Consult your Digital Sales Representative for more information.

# PROBATION

PROBATION DEPARTMENT

PROBATION DEPARTMENT

# 6 Terminals & Printers

---

As the personal interface to your computer system, Digital's terminals and printers give you the features you need to help you run at peak efficiency. Often you can eliminate bottlenecks by providing additional video terminals or a higher-speed system printer, and you can facilitate recordkeeping by placing a hardcopy terminal close to a group of users. Because they are so easy to use, versatile, and highly reliable, these terminals and printers can make you more productive, too.

The ASCII asynchronous *VT100 family of video terminals* provide an impressive list of standard features—features like nonvolatile setup memory, a detachable keyboard, 80- or 132-character line widths, selectable smooth or jump scrolling, and split-screen capability. Communications speeds go up to 19,200 baud. One of these video terminals is sure to meet your needs, whether they be text editing, word processing, program development, graphics, or personal computing.

Digital also provides a complete line of *hardcopy terminals* including both receive-only (RO) and keyboard send/receive (KSR) printing terminals. Each has its own unique combination of features and performance, so you can choose exactly what you need—letter-quality printing, for instance, or multiple character fonts or even automatic single sheet feed. All Digital hardcopy terminals share features that no one should do without—features like a choice of character sizes, multiple baud rates for flexibility in communications, 132 print columns.

In addition to the character printers, you can also choose from a variety of *lineprinters*, with speeds up to 1,200 lines per minute, and a new *laser page printer*.



# The VT100 Family of Video Terminals

Video Terminal Selection Chart

Model	Universal VT100 Family Features	Keyboard	Advanced Video Features	Graphics	Printer Port	Local Editing Block Mode	Personal Computing	Industrial	Local Echo	Async Comm	Modem Controls	Page
RT100-A, -B	✓	ANSI Numeric Flat Membrane Mylar	OPT					✓	OPT	Full Duplex	No	6-7
RT102-A, -B	✓	ANSI Numeric Flat Membrane Mylar	✓		✓			✓	Yes	Half/Full Duplex	Yes	6-7
RT137	✓	Keyboard Type Bar Code Template	OPT					✓	OPT	Full Duplex	No	6-7
VT100-A	✓	ANSI Numeric	OPT	OPT	OPT		OPT		OPT	Full Duplex	No	6-5
VT100-W	✓	Word Processing	✓		OPT		OPT		OPT	Full Duplex	No	6-5
VT101-A	✓	ANSI Numeric							Yes	Full Duplex	No	6-5
VT102-A	✓	ANSI Numeric	✓		✓				Yes	Half/Full Duplex	Yes	6-5
VT102-W	✓	Word Processing	✓		✓				Yes	Half/Full Duplex	Yes	6-5
VT125-A	✓	ANSI Numeric		✓	✓				No	Full Duplex	No	6-8
VT125-W	✓	Word Processing	✓	✓	✓				No	Full Duplex	No	6-8
VT131-A	✓	ANSI Numeric	✓		✓	✓			Yes	Half/Full Duplex	Yes	6-5

# The VT100 Family of Video Terminals

---

The VT100 family of video display terminals is designed to make the first-time user feel comfortable. A sculptured typewriter-like detachable keyboard connects to the video display unit by means of a 1.9 m (6 ft) coiled cord. The keyboard is used to set the terminal's functions. You can customize the display—set up tab stops, reverse the video image, and change the cursor from underline to block—to suit your application.

The advanced video features, optional on some models, give you three additional capabilities. First, you get a combination of 24 display lines and 132 columns. You also get space and connections for an extra character set that resides in the terminal. And you can display any character in any combination of blinking, underlined, bold, or reversed video.

The VT100 family terminals operate on full-duplex asynchronous communications lines and are equipped with a standard RS232-C interface, but you can add a 20mA interface if you like.

If you don't see a time in the future when you'll need all the expansion capabilities of the VT100, the economical VT101, VT102, and VT131 can give you substantial savings and additional features. If you need a terminal that can stand up to adverse conditions—a factory floor or warehouse, for instance—Digital offers you VT100-based terminals in ruggedized versions—the RT100 and the RT102. For such powerful graphics capabilities as business graphics, the VT125 provides a unique solution.

No matter what system you have, you've got a choice in the VT100 family. All members of the VT100 family share the universal VT100 performance characteristics.

## Universal VT100 Family Performance Characteristics:

- Baud rate: 50 to 19,200 b/s
- Format: 24 lines x 80 characters
- Characters: 7 x 9 dot matrix with descenders
- Character set: 94 displayable-character ASCII set and 32-character special line-drawing graphics set
- Double-width/double-size characters
- Standard numeric/function keypad
- Bidirectional vertical scrolling, selectable, smooth or jump scrolling
- Split-screen capability
- Normal or reversed screen image
- Adjustable tabs
- Full-duplex operation
- Keyboard selectable features
- Cursor control keys
- ANSI/VT52 command modes
- Line drawing character set
- 20 character answerback message
- Selectable XON/XOFF buffer control
- Self-test diagnostics
- Non-volatile set-up memory

# The VT100 Family of Video Terminals

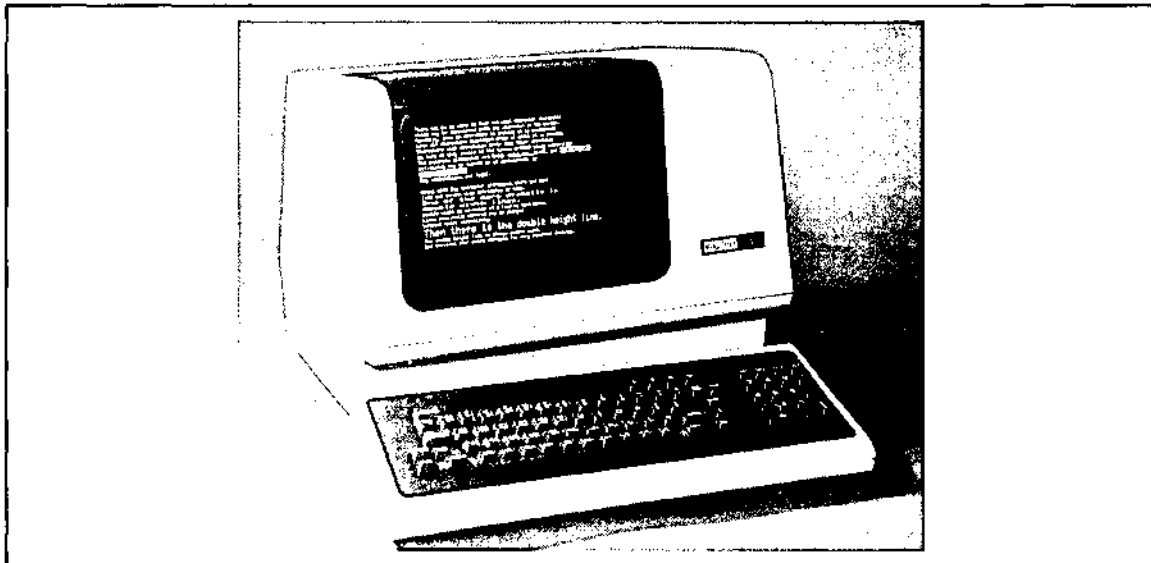

## VT100 Video Terminal

The VT100 is Digital's most basic and adaptable video terminal. Since additional space and power are built in, you can choose from a variety of upgrades and configurations that let you build a VT100 to your own specifications. If you add the advanced video option, you'll get the ability to display any character blinking, bold, underlined, or with its video image reversed (these features are standard on the VT102 and VT131). This basic terminal allows you to add graphics capability (which is standard on the VT125) at a later date.

With the word processing version, you get the advanced video features and gain keyboard compatibility with DECword/DP and the DECmail electronic mail system.

## VT101 Video Terminal

The VT101 video terminal offers the universal VT100 features and performance characteristics plus local echo. This local echo feature allows the user to attach the VT101 to non-Digital computer systems. Digital's host computers, which operate full duplex, echo characters as they are received, providing added assurance that the computer has correctly received the characters that were typed. In systems that do not incorporate this feature, the characters must be placed on the screen as they are being typed. The VT101 is a totally self-contained and highly reliable terminal with the lowest monthly maintenance cost of any Digital video terminal.

## VT102 Video Terminal

The VT102 terminal is a VT100 video terminal with built-in advanced video and printer port features that provide a wider variety of functions at a lower cost. The advanced video features make it easier to format documents, to prompt the user, to point out exceptions, or to provide guidance. Advanced editing features that allow character and line insert and delete are standard. The printer port is used for hardcopy printing without host intervention. The terminal and output device share one communication line so that they can communicate without taking up valuable CPU time.

The VT102 terminal can communicate in full-duplex (two-way simultaneous) or half-duplex (one-way transmission) mode, with local echo, using one of five modem-control selections. This provides optimum communication versatility—so the terminal can talk to a number of devices.

The word processing version increases the VT102's capabilities by giving you keyboard compatibility with DECword/DP and the DECmail electronic mail system.

## VT131 Video Terminal

The VT131 video terminal has full VT102 capability plus local editing and block mode transmission. Local editing allows the operator to enter and edit a full screen of data before transmitting it as a block of data to the host. The VT131 can be used in interactive mode on Digital computer systems and in block mode on non-Digital systems. *Note:* Block mode transmission is not supported on PDP-11 operating systems.

# The VT100 Family of Video Terminals

---

## Additional Performance Characteristics:

- Advanced video features: 24 lines x 132 characters and normal or reverse video, blinking, underline, and bold characters selectable on a character-by-character basis (on the VT102, RT102, VT131)
- Format: 14 lines x 132 characters, selectable (on the VT100 and VT101)
- Enhanced terminal editing features: insert line, delete line, insert character, and delete character (on the VT102, RT102 and VT131)
- Local print functions without host intervention (on the VT102, RT102 and VT131)
- Printer port for text output (on the VT102, RT102 and VT131)
- Protected fields and block mode (VT131)
- Half-duplex operation (on the VT102, RT102 and VT131)
- Full-duplex local-echo operation (on the VT101, VT102, RT102 and VT131)
- Modem controls (on the VT102, RT102 and VT131)

## Ordering Information:

- VT100-AA(AB)** Video display terminal
- VT100-WA(WB)** Video terminal with advanced video features and word processing keyboard
- VT101-AA(AB)** Video terminal with local echo
- VT102-AA(AB)** Video terminal with local echo, advanced video, and printer port
- VT102-WA(WB)** VT102-AA(AB) video terminal with local echo, advanced video, printer port, and word processing keyboard
- VT131-AA(AB)** Video terminal with local echo, advanced video, printer port, local editing, and block mode transmission



# The VT100 Family of Video Terminals



## Ruggedized Terminals

The RT100 is a ruggedized version of the VT100 suitable for industrial environments. It is protected by a sturdy sheet-steel case and heavy-duty filtration system. For added flexibility, it includes a hinged keyboard that allows you to shelf-mount the terminal conveniently at eye level.

The RT102 terminal is a ruggedized version of the VT102. It provides the full functionality and compatibility of the VT102, but is packaged to withstand hostile industrial environments. The RT102 has a mylar flat membrane keyboard that is resistant to most liquids, grease, and oil. Both display and keyboard are housed in durable metal enclosures with a ventilation fan. An easy-to-service, slide-out air filter greatly reduces dust and particulate infiltration.

The RT137 Bar Code Terminal combines the features of our ruggedized RT100 terminal with bar code capability, enabling it to handle factory data collection applications that require machine readable input. The terminal reads Code 39, interleaved 2-of-5, and Code 11.

A bar code reader is designed as an integral part of the RT137 architecture. The RT137 keyboard is a metal template keyboard which consists of bar code symbols representing alphanumeric characters and function key equivalents. For scanning the bar code, a shock and vibration-resistant light pen is provided. As an alternative to the light pen, a badge slot reader is available.

### Ordering Information:

<b>RT100-AA(AB)</b>	Industrial video terminal with RS232-C interface	<b>RT137-BA</b>	20mA version of the above
<b>RT100-BA(BB)</b>	20mA version of the above	<b>RT137-AE(BE)</b>	RT100 console, bar code reader, bar code keyboard, light pen (no VT100 keyboard)
<b>RT102-AA(AB)</b>	VT102-AA(AB) with EIA interface enclosed in a sheet metal shell, membrane keyboard	<b>RT137-AMB(M)</b>	RT100 console, bar code reader.
<b>RT102-BA(BB)</b>	20mA version of the above	<b>RT137-AK(BK)</b>	RT100 console, bar code reader, visible wand, RT100 keyboard (RT1XX-AC)
<b>RT137-AA</b>	RT100 console, bar code reader, bar code keyboard, VT100 keyboard, light pen. 120VAC/RS232-C.	<b>RT137-AC</b>	Bar code keyboard
		<b>RT137-AD</b>	Light pen
		<b>RT137-SR</b>	Badge slot reader

# VT125 Graphics Terminal

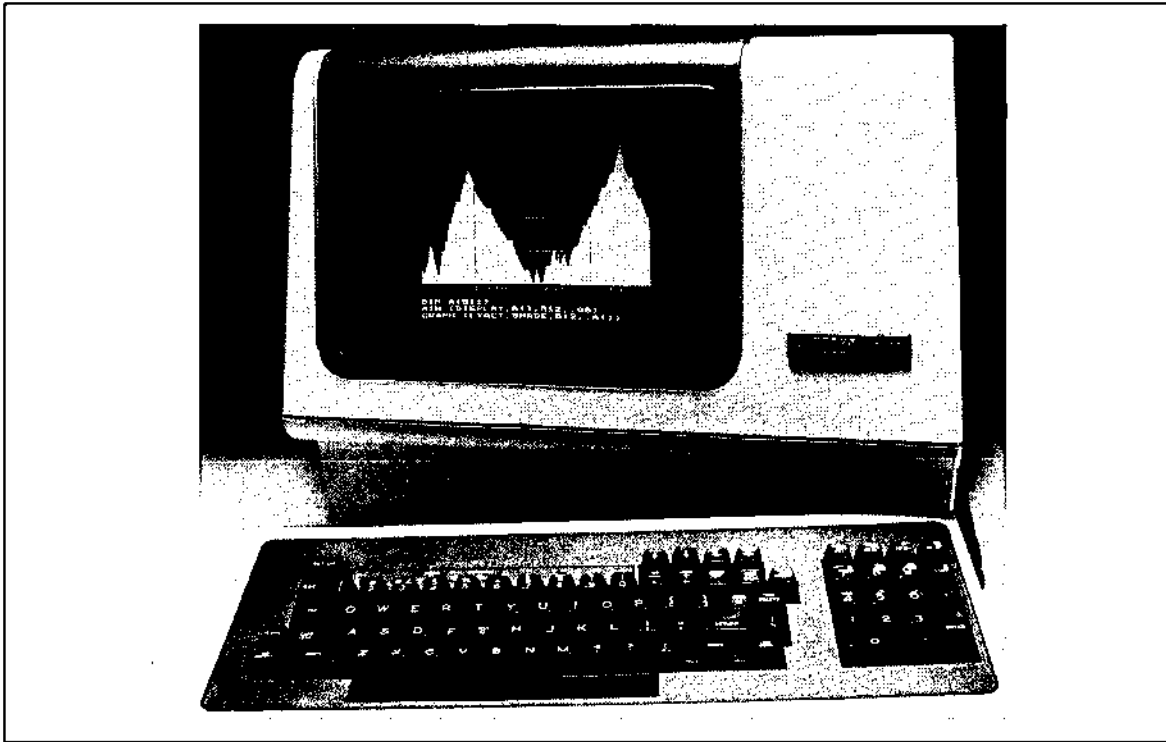

The VT125 combines the versatile features of the VT100 video terminal with graphics capability to become an easy-to-use data processing and graphics terminal. The VT125 is a microprocessor-based alphanumeric video terminal with data plotting extensions. The VT125 directly executes Digital's ReGIS (Remote Graphics Instruction Set). ReGIS commands are easy-to-remember single mnemonics and are easily inserted in programs written in any language, including BASIC, COBOL, and FORTRAN. With ReGIS you can produce bit map graphics and generate vectors and curves simply and automatically, instantly transforming complex data into easily understandable charts, graphs, and diagrams.

The VT125 comes with a black and white monitor. Two full graphics planes allow the terminal to display images one at a time, two at a time (for comparison), or combined to achieve varying levels of gray.

The word processing version of the VT125 graphics terminal has increased capabilities, which give you keyboard compatibility with DECword/DP and the DECmail electronic mail system.

You can use the VT125 to access your database. If you need hardcopy, use the integral printer port to attach an LA12 Correspondent, Letterprinter 100 terminal, or LA50 Personal Printer.

## Performance Characteristics:

- Universal VT100 family features
- Format: 24 lines x 80 characters or 14 lines x 132 characters, selectable
- Advanced video features (VT125-W): 24 lines x 132 characters, and normal or reverse video, blinking, underline, and bold characters selectable on a character-by-character basis

## Graphics Features:

- Graphics resolution: 768 x 240 pixels
- Two full graphics planes
- Firmware for direct execution of ReGIS commands
- Printer port for graphics mode
- Visual attributes: Black and white output with four gray levels

## Ordering Information:

**VT125-AA(AB)** Video terminal with graphics capability and printer port

**VT125-WA(WB)** Video terminal with graphics, advanced video features, word processing keyboard, and printer port

# VS11 Color Graphics Display Systems

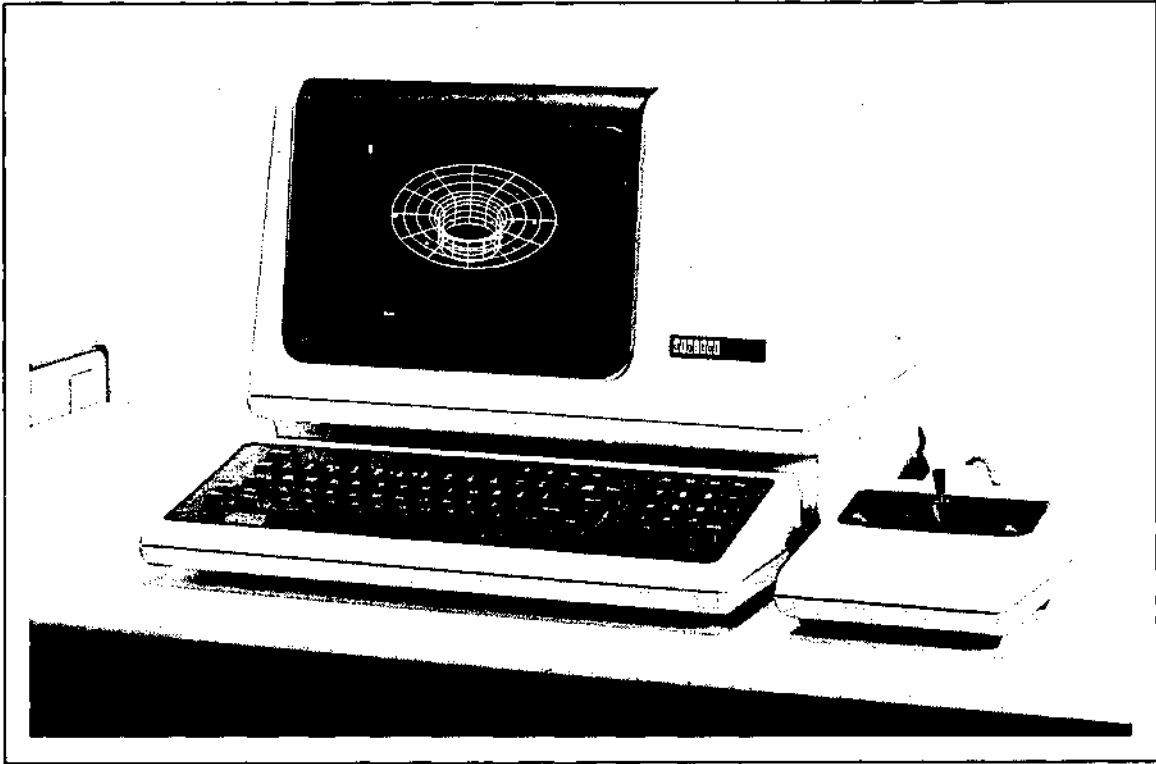

The VS11 is a high-performance, 16-color graphics system. It features a versatile graphics instruction set, bit-slice architecture, switch-selectable resolution and intensity for interlaced or non-interlaced operation.

The basic elements of the system are an image processor, image memory and sync generator. The image processor cycle-fetches graphic instructions (primitives) from the host's memory, interprets them, and fills the image memory with the appropriate data. The image memory is then scanned for display on the system monitor.

Two graphics software packages are available for the VS11 systems. Both are callable from FORTRAN. The first is called the FORTRAN DRAW package, utilizing a direct hardware access utility library with over 40 subroutines. The second package is VIGL, which is a high-level user-friendly graphics data analysis library. To order software, see Section 7 - Software.

**Note:** For information on Q-bus applications, contact Digital's CSS (Computer Special Systems group) Product Bulletin.

**Note:** To order software see Section 7 - Software.

# Video Terminal Options and Accessories

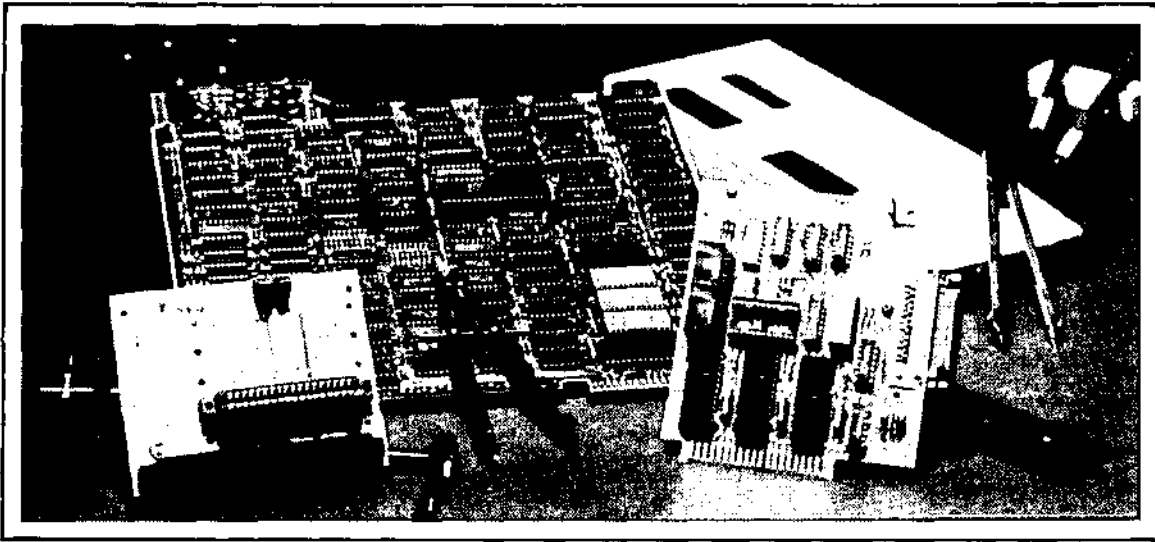

In addition to functional upgrade options, Digital carries a full range of accessories and supplies that are specifically designed for use with the VT100 family of video terminals. These options have been tested to Digital standards so you can be assured of their compatibility and reliability. Here is a selection of options and accessories:

<b>VT1XX-AA</b>	20mA interface adapter to convert VT100 terminal from an RS232-C interface to a 20mA current loop interface for communications lengths exceeding 15.2 m (50 ft). Includes BC05F-15 cable.	<b>VT1XX-CB</b>	Graphics upgrade kit to convert VT100 to VT125 graphics terminal.
<b>VT1XX-CA</b>	20mA interface adapter to convert VT100/VT101/VT102/VT125/VT131 from an RS232-C interface to a 20mA current loop interface for communications lengths exceeding 15.2 m (50 ft). Includes BC05F-15 cable.	<b>VT1XX-CE</b>	Word processing upgrade kit to convert VT100 and VT125 to word processing models.
<b>VT1XX-AB</b>	Advanced video option for the VT100/VT125. Provides four additional character attributes (bold, blink, underline, and reverse video in any combination), space and connections for an alternate character set memory thus allowing additional character sets to reside in the terminal, converts screen memory from 14 lines of 132 columns to 24 lines of 132 columns.	<b>VT1XX-SA</b>	Tilt/swivel base assembly providing an upward tilt of 15° and a downward tilt of 7.5°, plus 180° swivel capability for the VT100 family of video terminals.
<b>RT1XX-AE</b>	Noryl™ plastic and Mylar™ membrane keyboard fully compatible with the VT100 architecture. The VT100's keyboard functions are combined with a membrane panel providing a sealed unit. The Mylar membrane keyboard is resistant to moisture, dust, grease and oil. The RT1XX comes with a standard 6-foot coiled cord to attach to the monitor. Prerequisite is any VT100 family terminal.	<b>VT1XX-ST</b>	Five leg terminal stand with casters (requires customer assembly). Can be used for VT100 family terminals.
<b>VT1XX-AC</b>	Printer port option for connection of a VT100 to a hardcopy printer. Enables hardcopy printing off the video terminal, thus sharing one communication line between two peripherals. The printer port also allows local print functions without host intervention. <b>Prerequisite:</b> VT1XX-AB	<b>VT1XX-F</b>	Anti-glare panel. Reduces glare, enhances character contrast, and improves screen readability. Can be used with VT100 family. Easy to install and available in three colors:
		<b>VT1XX-FA</b>	Gray anti-glare panel.
		<b>VT1XX-FB</b>	Green anti-glare panel.
		<b>VT1XX-FC</b>	Bronze anti-glare panel.
		<b>VT1XX-K</b>	Keypad overlays that identify special function keys with preprinted plastic overlays:
		<b>VT1XX-KA</b>	KED/EDT for numeric keypads.
		<b>VT1XX-KB</b>	FMS/FED for numeric keypads.
		<b>VT1XX-KC</b>	FMS/FDV for numeric keypads.
		<b>VT1XX-KD</b>	Clear blank overlays for numeric keypads with labels.
		<b>VT1XX-BA</b>	Blank full keyboard overlays for user-defined keys.

™Noryl is a registered trademark of General Electric Co.

™Mylar is a registered trademark of DuPont de Nemours & Co., Inc.

# Configuring Information

**International Power Cord Ordering Table**

Model	U.S./GIA*	United Kingdom	Continental Europe	Switzerland	Australia	Japan
VT100	VT100-AA(AB) VT100-WA(WB) All have U.S. plugs.	N/A	N/A	N/A	N/A	N/A
VT101	VT101-AA(AB) All have U.S. plugs.	VT101-A2 Includes 240V power cord & U.K. plug.	VT101-A3 Includes 220V power cord & Continental Europe plug.	VT101-A4 Includes 220V power cord Swiss plug.	VT101-A5 Includes 250V power cord & plug.	VT101-AC Includes 100V power cord plug.
VT102	VT102-AA(AB) VT102-WA(WB) All have U.S. plugs.	VT102-A2 VT102-W2 Includes 240V power cord & U.K. plug.	VT102-A3 VT102-W3 Includes 220V power cord & Continental Europe plug.	VT102-A4 VT102-W4 Includes 220V power cord & Swiss plug.	VT102-A5 VT102-W5 Includes 250V power cord & plug.	VT102-AC VT102-WC Includes 100V power cord & plug.
VT131	VT131-AA(AB) All have U.S. plugs.	VT131-A2 Includes 240V power cord & U.K. plug.	VT131-A3 Includes 220V power cord & Continental Europe plug.	VT131-A4 Includes 220V power cord & Swiss plug.	VT131-A5 Includes 250V power cord & plug.	VT131-AC Includes 100V power cord & plug.
VT125	VT125-AA(AB) VT125-WA(WB) All have U.S. plugs.	N/A	N/A	N/A	N/A	N/A

\*General International Area. Those countries not included in the list above are members of GIA. For details as to power plugs available for GIA countries, please contact your Digital representative.

N/A means not available.

# Configuring Information

## Video Terminals

Model	20mA	Watts, Btu/hr	Height	Width	Depth	Weight
RT100-A,B	RT100-B	300, 512	41.9/4.5 cm 16.5/1.8 in	52.1 cm 20.5 in	61.6 cm 24.3 in	39 kg 86 lb
RT102-A,B	RT102-B	150, 341	41.9/4.5 cm 16.5/1.8 in	52.1 cm 20.5 in	61.6 cm 24.3 in	39 kg 86 lb
RT137-A,B	RT137-B	300, 512	41.9/4.5 cm 16.5/1.8 in	52.1 cm 20.5 in	61.6 cm 24.3 in	40 kg 88 lb
VT100-A,W	OPT (VT1XX-AA)	150, 512	36.8/8.9 cm 14.5/3.5 in	45.7 cm 18 in	51.4 cm 20.3 in	18.6 kg 41 lb
VT101-A	OPT (VT1XX-CA)	70, 240	36.8/8.9 cm 14.5/3.5 in	45.7 cm 18 in	51.4 cm 20.3 in	18.6 kg 41 lb
VT102-A,W	OPT (VT1XX-CA)	150, 512	36.8/8.9 cm 14.5/3.5 in	45.7 cm 18 in	51.4 cm 20.3 in	18.6 kg 41 lb
VT125-A	OPT (VT1XX-CA)	150, 512	36.8/8.9 cm 14.5/3.5 in	45.7 cm 18 in	51.4 cm 20.3 in	18.6 kg 41 lb
VT131-A	OPT (VT1XX-CA)	70, 240	36.8/8.9 cm 14.5/3.5 in	45.7 cm 18 in	51.4 cm 20.3 in	18.6 kg 41 lb

### Additional Information:

- Prerequisite for all terminals: EIA/CCITT serial line interface or equivalent.
- Communication cables: Communication cables are not provided with the VT100, RT100, VT101, VT102, RT102, VT131, and VT125 terminals and must be ordered separately. The recommended cables are BC22D-xx for local connection to a line unit and BC22B-xx for connection of the video terminal to a modem.
- Power cords: The VT101, VT102, and VT131 can be ordered with U.S. or European power cords (see International Power Cord Ordering Table). The BC05F cable is recommended for the 20mA RT100 and RT102 interface.
- Receptacles: NEMA #L5-15R for 120VAC video terminals, #L6-15R for 240VAC models.

## Hardcopy Terminals Selection Chart

Model	Keyboard	Print Speed & Quality	Graphics	Parts/Form	Paper Feed	Special Features	Page
LA12	KSR Embedded Num OPT External Num Keypad	150 ch/s Draft	Yes	2	Friction Pin Tractor OPT	Portable Built-in Modem or Acoustic Coupler	6-17
LA50	RO	100 ch/s Draft 50 ch/s Enhanced	Yes	3	Friction Low Tear-off Tractor	PC Compatible	6-14
LA100	KSR or RO	240 ch/s Draft 80 ch/s Enhanced 30 ch/s Letter	Yes	4	Friction Tractor Sheet OPT	Plug-in Fonts PC Compatible Pro 300 Graphics Available	6-16
LA120	KSR or RO	180 ch/s Draft	No	6 STD 9 OPT	Tractor Only	For High-duty Cycle Environment	6-18
LQP02	RO	32 ch/s Letter	OPT with CP/M DAISY-AIDS* Package	4	Friction Sheet OPT Tractor OPT	PC Compatible Full-Character Print	6-15

\*DAISY-AIDS is a trademark of Escape Computing Software, Inc. See the **Personal Computers Catalog**.

## Lineprinters Selection Chart

Model	Print Speed	Print Characters	Graphics	Technology	Page
LN01	12 pages/min	188	No	Non-Impact Laser	6-21
LP25	300 l/min 215 l/min	64 96	No	Band	6-22
LP26	600 l/min 445 l/min	64 96	No	Band	6-23
LP27	1200 l/min 800 l/min	64 96	No	Band	6-24
LSP25	300 l/min 215 l/min	64 96	No	Band	6-22
LSP26	600 l/min 445 l/min	64 96	No	Band	6-23
LXY12	300 l/min 240 l/min 170 l/min 42.4 cm/min 16.7 in/min	64 Uppercase 96 Upper/lower case Double height Plotting	Yes	Matrix	6-19
LXY22	600 l/min 465 l/min 320 l/min 84.6 cm/min 33.3 in/min	64 Uppercase 96 Upper/lower case Double height Plotting	Yes	Matrix	6-19

# LA50 Personal Printer

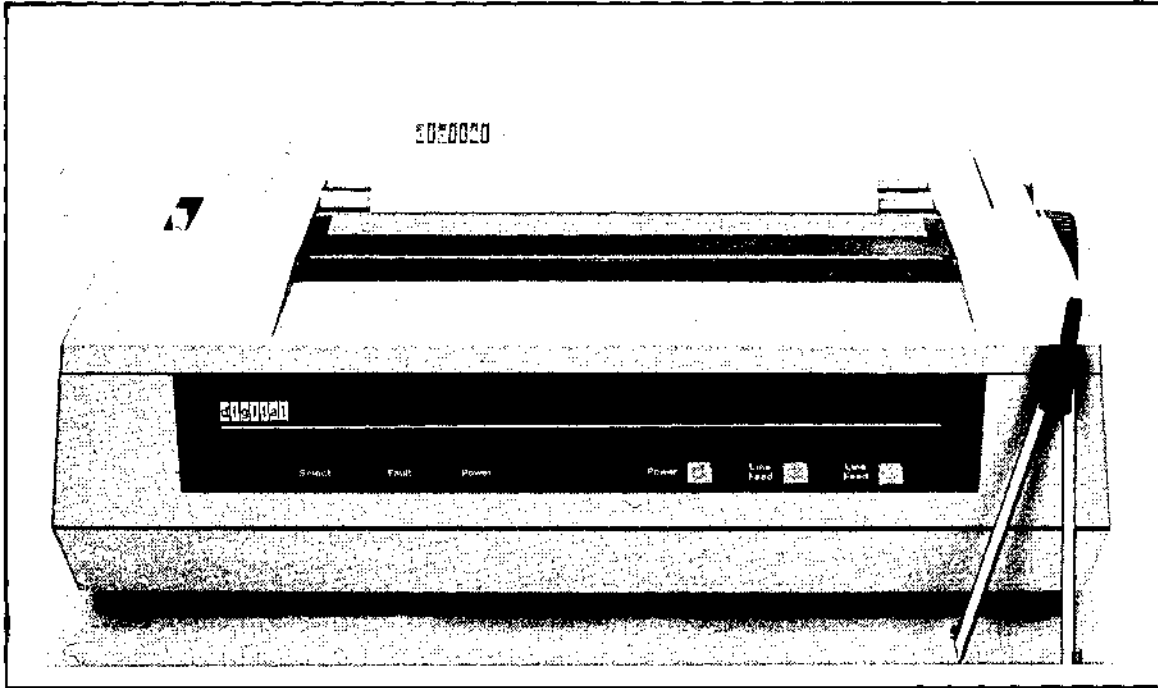

The LA50 Personal Printer is a lightweight, desktop, dot-matrix printer designed for use with Digital's personal workstations. Attach it to the printer ports on the VT100 family video terminals or to Digital's personal computers for complete compatibility. It features a text mode, an enhanced print-quality mode, and graphics capability. The LA50 printer can use regular office stationery, fan-fold paper, or multipart forms\* on a 25.4 cm (10 in) wide platen. For multilingual purposes, a multinational character set (Digital-standard) is resident in this terminal. The printer is customer-installable.

## Performance Characteristics:

- Baud rate: 110 to 4,800 b/s
- Print speed: 100 characters/s (text mode), 50 characters/s (enhanced print mode)
- Print columns: 80 to 132
- Character set:
  - 94 displayable-character ASCII set,
  - 81 multinational set (Digital-standard),
  - JIS Katakana set option,
  - 27 VT100 special graphics (line drawing) set plus ANSI-compatible escape sequences
- Characters per inch: 10, 12, 16.5 single width, 5, 6, 8, 25 double width
- Characters: 7 x 9 dot matrix impact printing in text mode; 13 x 9 in enhanced print mode
- Lines per inch: 2, 3, 4, 6, 8, 12
- Parity: Switch-selectable to odd, even, mark, or space; 7 or 8 bits per character (selectable)
- Print density: 144 or 180 dots/in horizontal (switch-selectable) and 72 dots/in vertical (in graphics mode)

## Ordering Information:

<b>LA50-RA</b>	Desktop printer with tractor feed, 110VAC power supply.
<b>LA50-RB</b>	Desktop printer with tractor feed, 220VAC power supply.
<b>LA50-RC</b>	Desktop printer with tractor feed, 240VAC power supply.

\* Digital recommends that multipart forms not exceed 0.028 cm (0.011 in) in thickness. This is usually equivalent to a three-part form.



# LQPO2 Full-Character Letter-Quality Printer

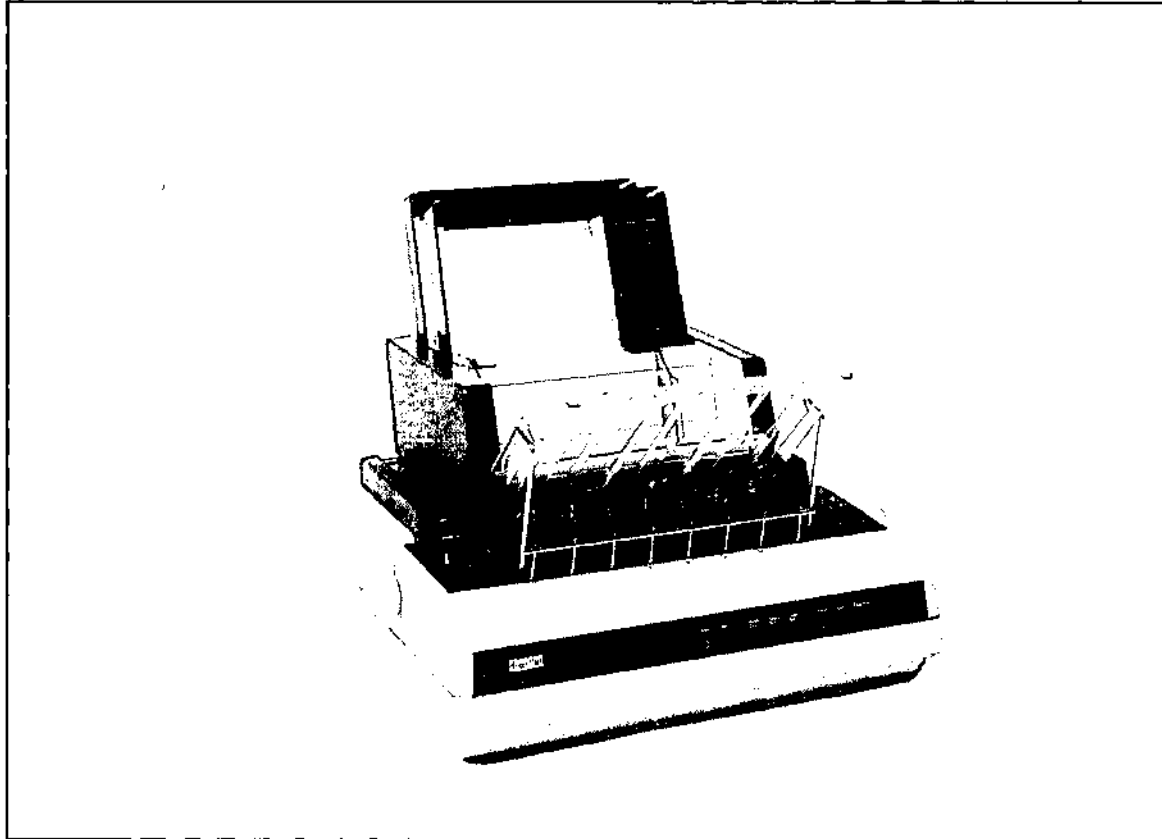

The LQPO2 letter-quality printer is a desktop full-character impact printer that incorporates daisy-wheel print technology. This highly reliable, customer-installable terminal will print high-quality hardcopy on regular office stationery as well as fan-fold paper. Various character fonts can be used by simply changing printwheels. Daisy wheels are inexpensive, easily interchangeable, and available in over 100 type styles and special purpose fonts. Smart bidirectional printing increases speed, particularly over large areas of white space. It operates on full-duplex, asynchronous communication lines and includes a universal power supply and a standard RS232-C interface.

## Performance Characteristics:

- Baud rate: 110 to 9600 b/s
- Print speed: 32 characters/s (Shannon Text)
- Print method: Impact, daisy wheel
- Print columns:
  - 132 at 10 ch/in
  - 158 at 12 ch/in
- Character set: over 100 different, 7-bit ASCII
- Characters per inch: 10/12 variable, software-selectable
- Lines per inch: 6 or 8 variable, software-selectable
- Variable horizontal tabs and margins
- Paper: Tractor-fed or single-sheet
- Ribbon: fabric or mylar
- Universal power supply, user-selectable
- Parity: Switch-selectable to odd, even, mark, or space; 7 bits per character

## Ordering Information:

- |                     |   |
|---------------------|---|
| <b>LQP02-AA(AD)</b> | Letter-quality printer with Courier-10 font.  |
| <b>LQPX2-AA</b>     | Bidirectional forms tractor option for use with fan-fold paper.                       |
| <b>LQPX2-SF</b>     | Dual-tray cut-sheet feeder; feeds in vertical or horizontal mode and collates output. |
| <b>LQPX2-FB(FD)</b> | Acoustic cover for LQP02-AA(AD).  |

# LA100 Letterprinter 100/Letterwriter 100

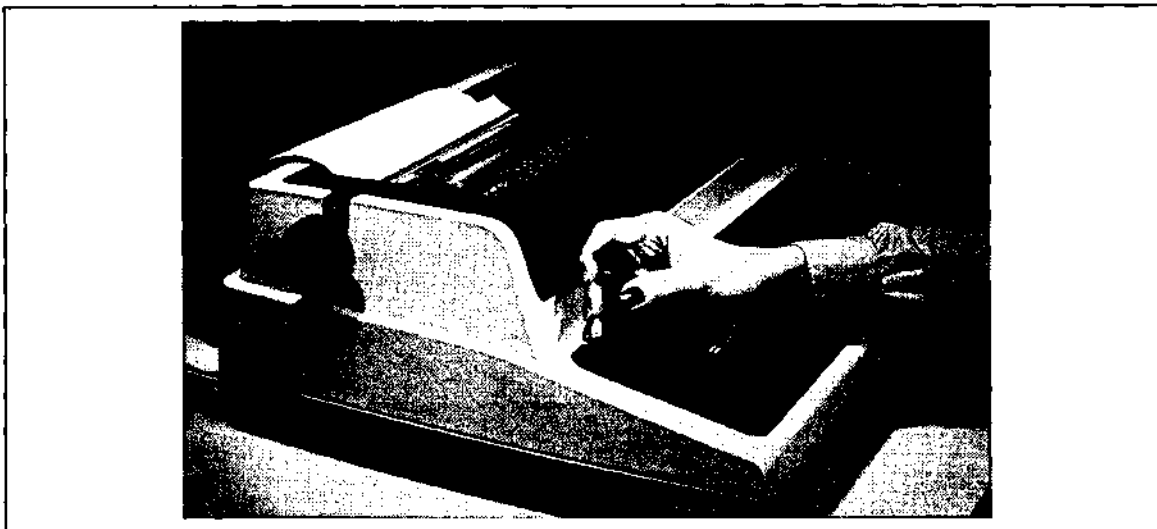

The Letterprinter 100/Letterwriter 100 are desktop, microprocessor-controlled printers. The Letterprinter 100 is the receive-only (RO) version, while the Letterwriter 100 is a keyboard send/receive (KSR) terminal. Highly versatile and multimode, the Letterprinter 100 is ideal for use with video workstations and small business systems. These printers offer two text modes—draft-quality and letter-quality—as well as bit map graphics. LA100s print on fan-fold computer paper, roll paper, and office stationery. The user can select from a variety of resident type faces or a greater selection of plug-in cartridges. The LA100-PC model, designed for use with Digital's personal computers, offers graphics compatibility with Professional 300-series computers. (Note: The LA100-PC model uses different font cartridges than the other LA100 models.) These printers can handle a wide variety of applications in distributed data processing, word processing, graphic imaging, communications, and electronic mail.

The read-only Letterprinter 100 is really three printers in one: a draft printer, a letter printer, and a graphics printer—with multiple fonts.

The KSR Letterwriter 100 is *the* system console, Digital's newest and fastest KSR printer/terminal.

The LA100 printer operates on full-duplex asynchronous communications lines and each includes universal power supply, standard RS232-C interface, and RS232-C null modem cable (BC22D-xx).

## Performance Characteristics:

- Baud rate: 50 to 9600 b/s
- Print speed:
  - 240 characters/s in draft printing,
  - 30 characters/s in letter printing,
  - 80 characters/s in memo printingmay be ordered as an option
- Slew speed: 12.7 cm/s (5 in/s)
- Print columns: 217
- Character set: 7-bit ASCII for 9 countries, plus ANSI-compatible escape sequences, 8-bit Digital-standard 169 multinational and VT100 line drawing graphics (for LA100-PC)
- Characters per inch: 5,6,8,6,8,25,10,12,13,2,16,5
- Characters:
  - 7 x 9 dot matrix impact draft printing
  - 33 x 9 dot matrix impact memo printing
  - 33 x 18 dot matrix impact letter printing
  - 132 x 72 dot matrix impact printing in graphics mode
- Lines per inch: 2,3,4,6,8,12
- Universal power supply
- Parity: Even, odd, or none; 7 or 8 bits per character, selectable

## Ordering Information:

- LA100-BA(BB)** English language KSR printer with numeric keypad, tractors, ribbon, paper, and BC22D-10 cable.
- LA100-CA(CB)** LA100-BA(BB) plus multiple-font capability.
- LA100-PC** RO printer for use with Digital's personal computers, includes 8-bit Digital-standard 169 multinational character set, U.S. Courier-10, multinational Courier-10, VT100 line-drawing character set, Professional Computer (PC) compatible graphics ratios, tractors, built-in multiple-font option.
- LA100-ZA(ZB)** English language RO printer plus multiple-font adapter, tractors, ribbon cartridge, paper, paper-out switch, U.S. and European power supply, Courier-10 U.S. ASCII character set font ROM chip, BC22D-25 signal cable, Orator-10 U.S. ASCII character set font ROM chip, and three user-specifiable font ROM slots.

\* All A models are 120VAC, all B models are 220VAC

# LA12 DECwriter Correspondent



The DECwriter Correspondent (LA12) is a lightweight interactive terminal which prints on plain bond paper, as well as fan-fold and roll paper. With the Correspondent, you can also print two-part forms. A variety of user-selectable features allows the portable correspondent to be adapted to a number of applications in many locations. The Correspondent is well-suited to all four major application categories: on-line timesharing, database information retrieval, networking, or program development. You can select several integral communication modes—acoustic coupler, direct connect modem, and direct-connect RS232-C port—to connect your terminal to a computer from virtually any location. These flexible communication ports allow more location independence to the professional than ever before.

For international use, the Correspondent is compatible with all Bell and European modem protocols. You can select from ten international character sets. Communication cables are not included. The BC22D-XX is recommended.

## Performance Characteristics:

- Baud rate: 50 to 9600 b/s
- Print speed: 150 characters/s (text mode)
- Slew speed: 5 in/s
- Print columns: 132
- Character set: 94-character ASCII set, 9 international sets, VT100 special graphics, APL character set
- Characters per inch: 5, 6, 6.6, 8, 25, 10, 12, 13.2, 16.5
- Characters: 9 x 9 dot matrix impact printing in text mode
- Lines per inch: 2, 3, 4, 6, 8, 12, user-selectable
- Universal power supply, user-selectable
- Parity: Switch-selectable to odd, even, mark, or space; 7 or 8 bits per character selectable
- Print density: 132 dots/in horizontal, 72 dots per inch vertical (graphics mode variable)
- Extensive self-contained user diagnostics

## Ordering Information:

**LA12-AB** Portable hardcopy terminal with integral 1200 baud dial-through-the-keyboard modem, 300 baud coupler and EIA interface. Includes carrying case.

- LA12-CB** LA12 with integral 300 baud coupler and EIA interface. Includes carrying case.
- LA12-DB** LA12 tabletop and console model, EIA interface only.
- LA12-D** Hardcopy terminal with RS232-C interface and accessories—paper roll 30.4 m (100 ft), ribbon cartridge, instruction card, loop-back connector, and line cord.
- LA12-C** LA12-D plus integral 300 baud acoustic coupler, carry case, shoulder strap.
- LA12-B** LA12-D plus 300/1, 200 baud modem, carry case, shoulder strap.
- LA12-A** LA12-D plus integral 300/1, 200 baud modem, 300 baud acoustic coupler, carry case, shoulder strap.

## Upgrade Kits:

- LAX12-U2** Dial-through-the-keyboard 1200 baud integral modem
- LAX12-U4** 300 baud acoustic coupler
- LAX12-U5** Enhanced microcode

# LA120 DECwriter III Printing Terminal

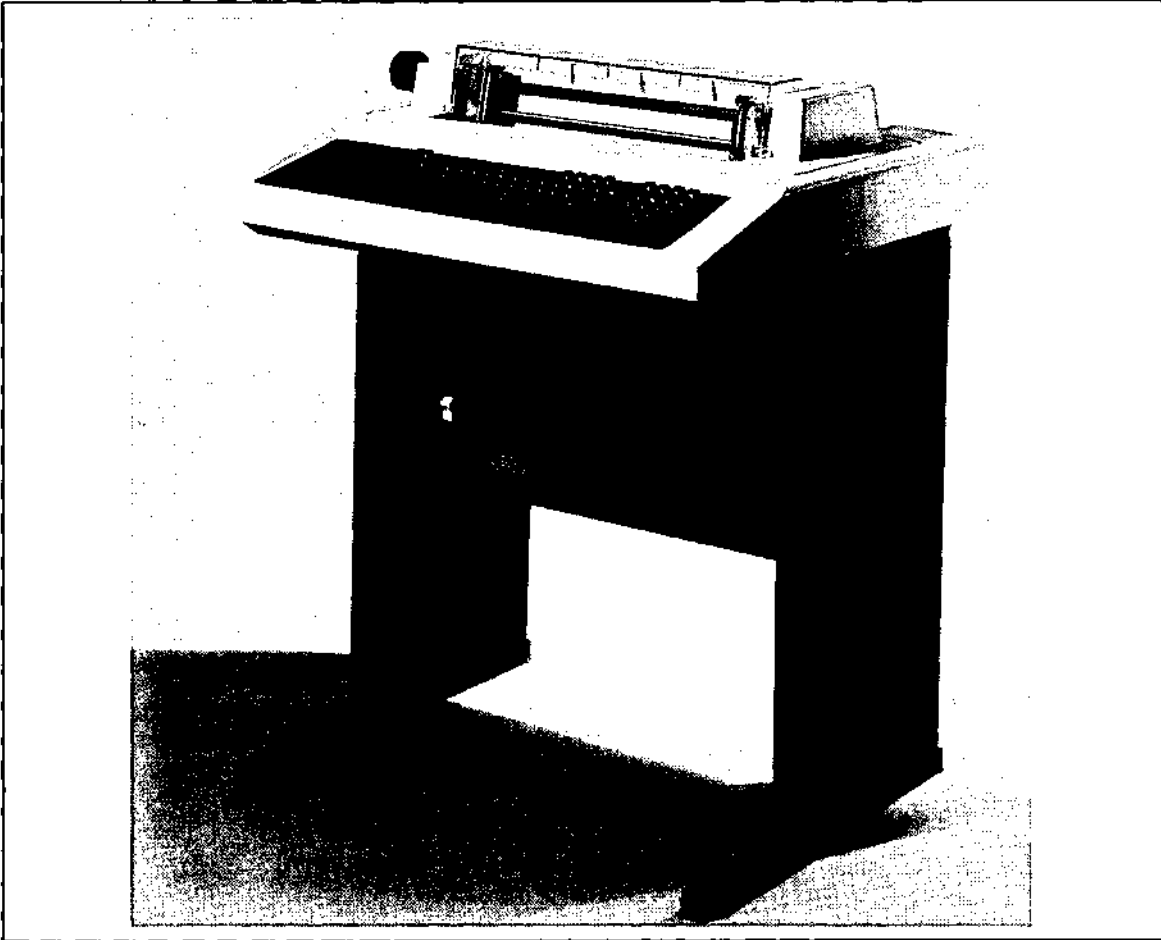

The freestanding DECwriter III terminal is one of the sturdiest printers you can buy. It has been designed for the high duty-cycle environment. You can choose between receive-only (RO) and keyboard send/receive (KSR) versions. The LA120 is optimized for 1200 baud communications, with capabilities for a dozen other rates from 50 to 9600. Throughput is increased by combining bidirectional smart printing (seeks the terminal shortest path to next print position) with a 1000 character buffer with fast horizontal and vertical skipping over white space. In addition, 45 set-up features—like character size, line spacing, forms length, margins, and tabs—are easily selected from the keypad. The LA120 KSR printing terminal features a contoured, typewriter-styled keyboard with N-key roll-over. The LA120 operates on five half- and full-duplex asynchronous communications lines, with a 30-character answerback for security, and standard RS232-C/CCITT interface. Includes universal power supply.

## Performance Characteristics:

- Baud rate: 50 to 9,600 b/s
- Print speed: 180 characters/s
- Lines per inch: 2,3,4,6,8,12
- Characters per inch: 5,6,6.6,8.25,10,12,13.2 or 16.5
- Characters: 7 x 7 dot matrix
- Character set: 7-bit ASCII plus ANSI-compatible escape sequences
- Tabs: 217 horizontal, 168 vertical
- Font sizes: 8
- Line spacings: 6
- Parity: Odd, even, or none

## Ordering Information:

- |          |                                      |
|----------|--------------------------------------|
| LA120-DA | DECwriter III KSR hardcopy terminal. |
| LA120-RA | DECprinter III RO hardcopy terminal. |

# LXY Graphics Lineprinters

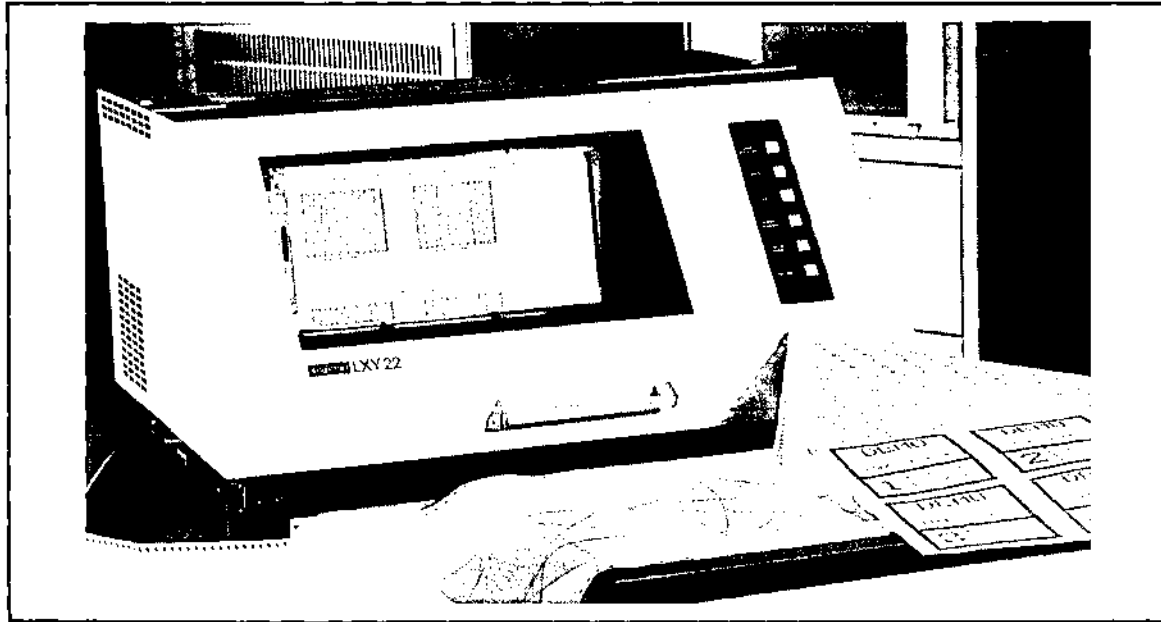

The LXY12 and LXY22 graphics lineprinters are versatile dot-matrix printers that combine the benefits of a line printer and a plotter in one product. These printers are compatible with all other Digital lineprinters, requiring no special software to use them as lineprinters.

These printers can be connected to the system using either an LP11 controller or a serial (RS232-C) port. The LP11 controller offers the benefits provided by faster parallel throughput and full data transfer speeds. The RS232-C interface provides remote connection to the CPU via a serial line interface and standard null modem cables.

Two software packages (**PLXY** and **BCP**) that increase the versatility of these graphics lineprinters are available. These are further described in Section 7.

**PLXY-11 Graphics Software Package** gives RT11, RSX-11M, RSX-11M-PLUS, and RSTS/E users the ability to produce graphs, charts, bar charts, designs, plots, and line drawings.

**BCP Bar Code/Block Character Graphics Software Package** gives RSX-11M users the ability to produce CODE 39 barcode, block characters, horizontal and vertical thick and thin lines, horizontal and vertical bars, 0.25 cm (0.1 in) text characters and variable sized characters.

## Performance Characteristics:

- Printing speed:  
LXY12:  
300 l/min (uppercase only)  
240 l/min (underlines, upper/lowercase characters with descenders)  
170 l/min (double-height characters)  
LXY22:  
600 l/min (64 uppercase characters)  
465 l/min (underlines, upper/lowercase characters)  
320 l/min (double-height characters)
- Plotting speed:  
LXY12: 42.4 cm/min (16.7 in/min)  
LXY22: 84.6 cm/min (33.3 in/min)
- Character set: 96 ASCII standard (expansion to 192 characters optional)
- Paper slew speed:  
LXY12: 20.3 cm/s (8 in/s)  
LXY22: 40.6 cm/s (16 in/s)
- Buffer capacity: 132 characters
- Speeds based on parallel interface

## Ordering Information:

**LXY12-CA(CB)** 300 l/min dot matrix graphics lineprinter, supplied with 7.6 m. (30 ft.) cable, a pedestal with basket, paper guide, and LP11 controller. UNIBUS interface.

**LXY22-CA(CB)** 600 l/min version of the above.

**LXY12-DA(DB)** 300 l/min dot matrix graphics lineprinter, supplied with cable, a pedestal with basket, paper guide, and RS232 serial port.

**LXY22-DA(DB)** 600 l/min version of the above.

## Software

**BCP** Interactive package for printing bar codes and block letters on the LXY12/LXY22 graphics lineprinters

**PLXY-11** Graphics application development package for LXY12/LXY22 graphics lineprinters

**Note:** Software must be specified when ordering hardware. See Section 7 - Software for further descriptions of BCP and PLXY-11. Make your selection from the following chart.

# LXY Graphics Lineprinters

---

## Applications Packages for LXY Graphics Lineprinters

Order Code				
Product	RT-11	RSTS/E	RSX-11M	RSX-11M-PLUS
BCP			QJS05-AM,AH (14.72.xx)	
PLXY-11	QJS91-XM (12.42.xx)	QJS92-XM (14.16.xx)	QJS90-XM (14.39.xx)	QJS95-XM (14.71.xx)

# LNO1 Laser Printer

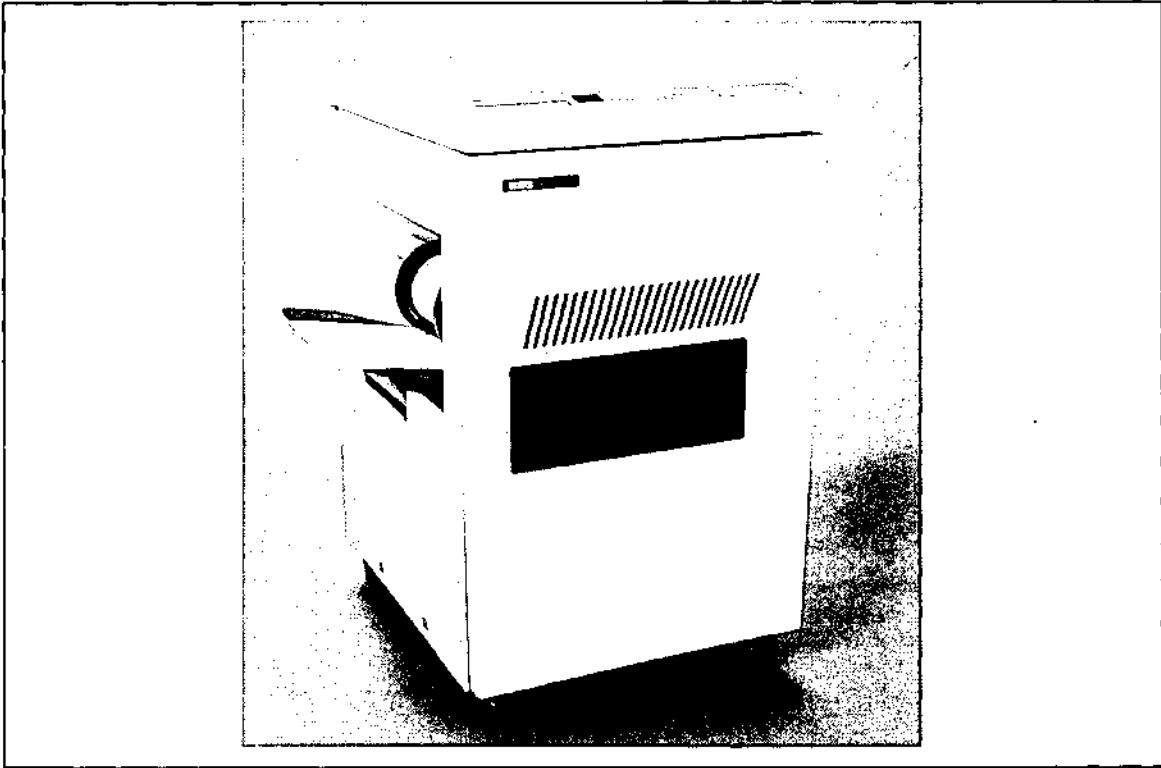

The LNO1 page printer is a high-quality nonimpact printer that employs laser technology. The LNO1 provides the speed of a lineprinter with exceptional print quality. Using electrophotographic imaging and xerographic printing, the LNO1 prints one page at a time, twelve pages per minute. The print resolution of 300 x 300 dots per square in produces perfectly formed characters of even density and alignment. Since every page is an original, every copy is as crisp and clear as the first.

The printer provides for the transfer of data via a parallel interface. Its quietness, high speed, high-resolution print quality, and flexibility make the LNO1 particularly well-suited for office environments, data centers, letter quality requirements, and scientific markets.

## Performance Characteristics:

- Printing speed: 12 pages/min maximum
- Character sets: 2 188-character fixed-space fonts
- Print modes: Portrait and landscape
- Print resolution: 300 x 300 dots per square in
- Print columns: Up to 132
- Lines per inch: 8.57
- Characters per inch: 13.6, 12.5 for Europe
- Paper handling: Cut-sheet plain paper, 2 250-sheet cassettes 1.1-1.6 kg (16-24 lb) paper
- Paper Sizes:
  - Standard: 21.6 x 27.9 cm (8.5 x 11 in)
  - Legal: 21.6 x 35.6 cm (8.5 x 14 in)
  - European: 21 x 29.7 cm (8.3 x 11.7 in)
- Noise Level: Less than 55 DbA

## Ordering Information:

- LN01-CA(CB)** Non-impact 12 page/min laser printer with LP11 interface and 9.1 m (30 ft) cable.
- LN01-DA(DB)** Non-impact 12 page/min laser printer with DMF32-compatible 9.1 m (30 ft) cable.

## Site Preparation Specifications:

- Height: 91.4 cm (36 in)
- Width: 65.5 cm (25.8 in)
- Depth: 66 cm (25.9 in)
- Weight (with pedestal): 136 kg (300 lb)
- Watts: 1150
- Btu/hr: 3620
- Receptacles required: NEMA #5-15R(120VAC); NEMA #6-15R(240VAC)

# LP25 300 L/Min Lineprinter

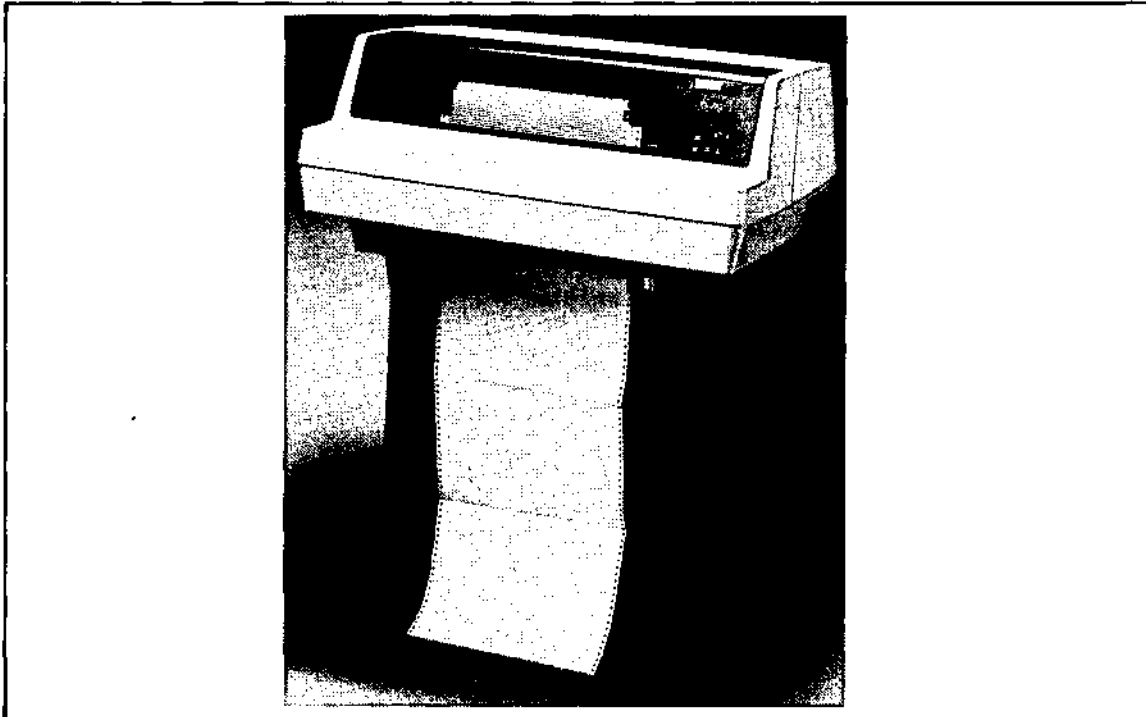

The LP25 band printers feature easily interchangeable, user-replaceable font bands that include optional bands for a compressed printing mode, and European and Japanese character sets. Two primary models are available; one for 64 character bands, and one for both 96 and 64 character bands. Use of a 64 character band on the 96 character model enables automatic output foldover to 64 characters. The standard LP25 lineprinters are equipped with a control unit, a 9.2 m (30 ft) cable, and a universal power supply. The long-line version of the 96/64 character model, the LSP25-CA permits operation of the printer up to 152.5 m (500 ft) from the CPU. A 15.2 m (50 ft) cable is supplied with the LSP25.

## Performance Characteristics:

- Printing speed:
  - 64-character set: 300 l/min
  - 96-character set: 215 l/min
- Number of columns: 132
- Horizontal spacing: 0.25 cm (0.1 in), 10 ch/in or 15 ch/in compressed. **Note:** Compressed font decreases throughput by 30%.
- Vertical spacing: 6 or 8 l/in, switch-selectable
- Vernier adjustment for both horizontal and vertical paper tension
- Slew speed: 37.5 cm/s (15 in/s)
- Buffer capacity: 132 characters
- Program status display
- Self-test capability

## Ordering Information:

LP11-AA	Band printer, 300 l/min for 64-character ASCII set (UNIBUS).
LP11-BA	Band printer, 300 l/min for 64-character set or 215 l/min for 96-character ASCII set (UNIBUS).
LPV11-AP	System option. Band printer, 300 l/min for 64-character ASCII set (Q-bus).
LPV11-A	Upgrade option. Select one of the following cabinet kits:
CK-LPV1A-KA	Cabinet kit for MICRO/PDP-11.
CK-LPV1A-KB	Cabinet kit for PDP-11/23-S.
CK-LPV1A-KC	Cabinet kit for PDP-11/23-PLUS.
LPV11-BP	System option. Band printer, 300 l/min for 64-character set or 215 l/min for 96-character ASCII set (Q-bus).
LPV11-B	Upgrade option (see cabinet kits above).
LSP25-CA	U.S. prom set, 64 and 96 character U.S./U.K. bands, universal power supply, 15 m (50 ft) cable, 300/215 l/min.

**Note:** For further cabling information on the LSP25, see Digital's CSS (Computer Special Systems group) Product Bulletin.



# LP26 600 L/Min Lineprinter

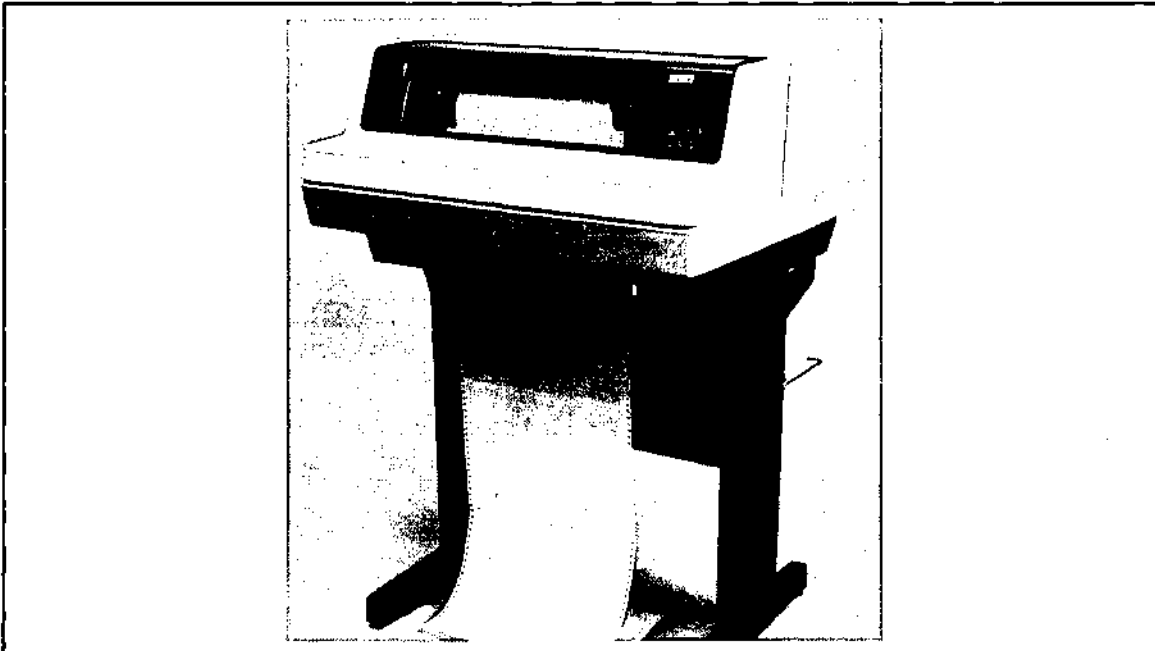

The LP26 band printers feature easily-interchanged, user-replaceable font bands with optional bands for American and European character sets. They utilize a flat steel band with raised letters and a hammer bank with 132 hammers (one for each column). As the selected character appears on the moving band, each hammer strikes one character to produce a clear printed line. Two primary models are available; one for 64 character bands, and one for both 96 and 64 character bands. Use of a 64 character band on the 96 character model enables automatic output foldover to 64 characters. The standard LP26 lineprinters are equipped with a control unit and a 9.2 m (30 ft) cable, as well as universal power supply. The long-line version of the LP26-CA, the LSP26-CA, is available for operation of the printer up to 152.5 m (500 ft) from the CPU. A 15.2 m (50 ft) cable is supplied with the LSP26.

## Performance Characteristics:

- Printing speed:
  - 64-character set: 600 l/min
  - 96-character set: 445 l/min
- Number of columns: 132
- Horizontal spacing: 0.25 cm (0.1 in)
- Vertical spacing: 6 or 8 l/in, switch-selectable
- Vernier adjustment for both horizontal and vertical paper tension
- Slew speed: 37.5 cm/s (15 in/s)
- Line advance time: 25 msec
- Buffer capacity: 132 characters, single-line
- Self-test capability
- Paper type: Pin-feed, continuous, fan-fold forms
- Copies: 1- to 6-part plus carbon paper
- Maximum paper thickness: 0.056 cm (0.022 in)
- Modular design for easy parts removal/replacement during routine servicing and maintenance
- Reliable, medium-load performance

## Ordering Information:

<b>LP11-EA</b>	Bandprinter, 600 l/min for 64-character set (UNIBUS).
<b>LP11-EB</b>	Bandprinter, 600 l/min for 64-character set or 445 l/min for 96-character set (UNIBUS).
<b>LPV11-EP</b>	System option. Bandprinter, 600 l/min for 64-character set (Q-bus).
<b>LPV11-E</b>	Upgrade option. See cabinet kit selection for LPV11-F.
<b>LPV11-FP</b>	System option. Bandprinter, 600 l/min for 64-character set or 445 l/min for 96-character set (Q-bus).
<b>LPV11-F</b>	Upgrade option. Select one of the following cabinet kits:
<b>CK-LPV1A-KA</b>	Cabinet kit for MICRO/PDP-11.
<b>CK-LPV1A-KB</b>	Cabinet kit for PDP-11/23-S.
<b>CK-LPV1A-KC</b>	Cabinet kit for PDP-11/23-PLUS.
<b>LSP26-CA</b>	U.S. prom set, 64 and 96 character U.S./U.K. bands, universal power supply, 15.2 m (50 ft) cable, 600/445 l/min.

**Note:** For further information on the LSP26, see Digital's CSS (Computer Special Systems group) Product Bulletin.

# LP27 1200 L/Min Lineprinter

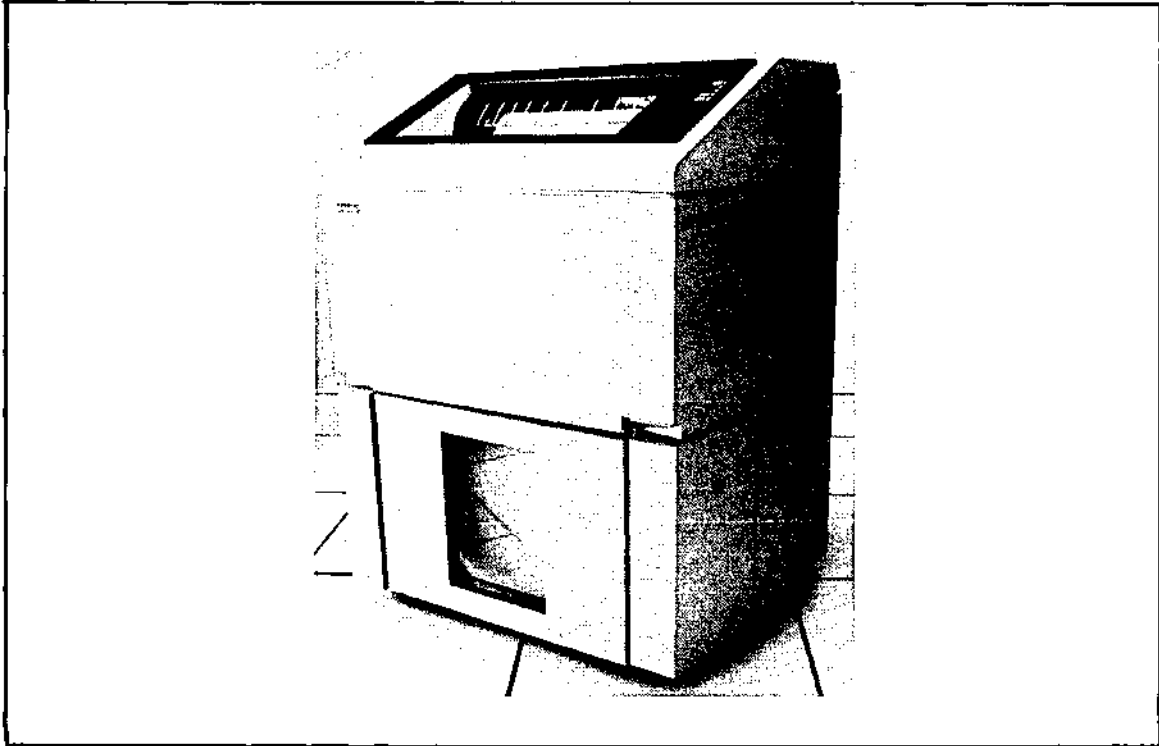

The LP27 is a 132-column, fully formed character, impact lineprinter. It includes both 64 and 96 character American print bands as standard on all versions. Maximum print throughput is 1200 lines per minute using the 64 character band or 800 lines per minute with the 96-character band.

The LP27 is designed for use on larger UNIBUS systems in a standard computer room environment. It uses continuous, fan folded, pin feed forms (single part up to six part) in a wide range of widths 8.8 cm to 47.6 cm (3.5 to 18.75 in), lengths 7.6 cm to 37.4 cm (3 to 14.75 in) and weights 6.8 kg bond to .05 cm card stock (15 lb bond to .02 in card stock).

The LP27 is a heavy-duty lineprinter notable for its throughput, reliability, and its easy maintenance.

## Performance Characteristics:

- Printing speed:
  - 64-character set — 1200 l/min (maximum)
  - 96-character set — 800 l/min
- Number of columns: 132
- Horizontal spacing: 10 ch/in
- Vertical spacing: 6 or 8 l/in, switch-selectable
- Slew speed: 127 cm/s (50 in/s)
- Line advance time: 14 msec maximum
- Buffer capacity: 132 characters, single-line
- Self-test capability: Yes (three modes)
- Paper type: Pin feed, continuous fan-fold forms
- Copies: One to six-part plus carbon paper
- Paper thickness: 6.8 kg bond (15 lb bond) to .05 cm card stock (0.02 in card stock)

## Ordering Information:

- LP27-UA(UB)** LP27 with 9.5 m (30 ft) data cable and controller. Shortline interface permits operation up to 14.8 m (49 ft) from host processor. For more information on print bands, see the DECdirect Catalog.

# CR11 Card Readers

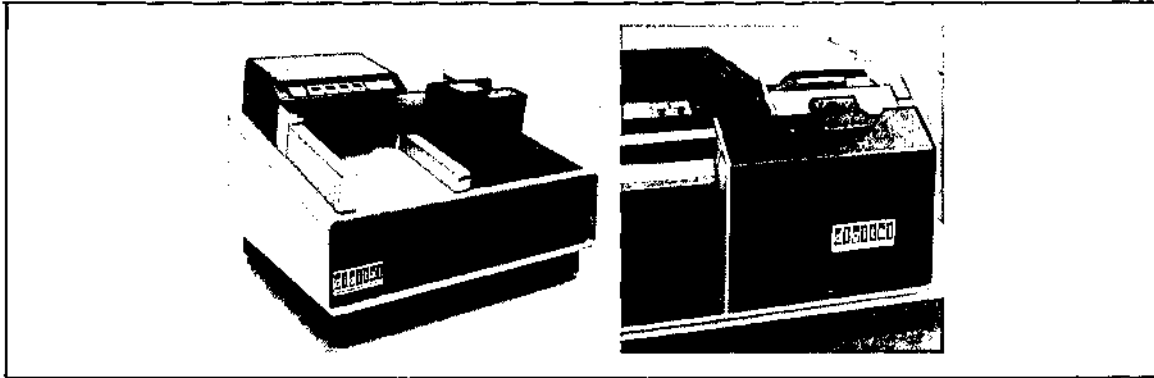

The CR11 and CR11-B photoelectric card reader systems read hole-punched cards and feature two data formats that are selectable under program control: nonpacked (standard Hollerith code) and packed (compressed Hollerith code). A raffle air mechanism and a short, straight card track prevent card jams, and six attempts are made to read a card before it is rejected. The card readers are self-contained tabletop units consisting of an input hopper for loading cards, a photoelectric read station for reading data from cards, an output stacker for stacking cards after reading, a motorized mechanism for moving the cards from the input hopper via the read station to the output stacker, a controller, and 7.6 m (25 ft) cable.

The CR11(A) is designed for laboratory and industrial applications; the CR11-BC(BD) is designed for engineering and industrial applications.

## Performance Specifications:

- Card speed:
  - CR11—285 cards/min
  - CR11-B—600 cards/min
- Card capacity:
  - CR11—550
  - CR11-B—1000
- Card type: Standard 12-row 80-column RS232-C (Hollerith code) hole-punched cards
- Data formats: Nonpacked and packed (selectable under program control)
- Raffle air system
- Vacuum pick mechanism

## Site Preparation Specifications:

### CR11/CR11-A

- Height: 27.9 cm (11 in)
- Width: 48.9 cm (19.3 in)
- Depth: 35.6 cm (14 in)
- Weight: 27.2 kg (60 lb)
- Watts: 600
- Btu/hr: 2,046
- Receptacles required:
  - NEMA #5-15R (120VAC)
  - NEMA #6-20R (240VAC)

### CR11-BC-BD

- Height: 41.3 cm (16.3 in)
- Width: 58.4 cm (23 in)
- Depth: 45.7 cm (18 in)
- Weight: 34 kg (75 lb)
- Watts: 700
- Btu/hr: 2,387
- Receptacles required:
  - NEMA #5-15R (120VAC)
  - NEMA #6-20R (240VAC)

## Ordering Information:

<b>CR11</b>	Tabletop card reader and controller; 120 VAC, 60 Hz.
<b>CR11-A</b>	Tabletop card reader and controller; 240 VAC, 60 Hz.
<b>CR11-BC</b>	Tabletop card reader and controller; 120 VAC, 60 Hz.
<b>CR11-BD</b>	Tabletop card reader and controller; 240 VAC, 60 Hz.

## Card Readers — Configuring Information

Model	Mounting Requirements	DC Amps Drawn @ +5V / +15V / -15V	Bus Loads Drawn	Height	Width	Depth	Weight
CR11	1 Quad slot	1.5 / 0.00 / 0.00	1	11 in. (28 cm)	19.3 in. (49 cm)	14 in. (35.6 cm)	60 lbs. (27.2 kg)
CR11-B	1 Quad slot	1.5 / 0.00 / 0.00	1	16.3 in. (41.3 cm)	23 in. (58.4 cm)	18 in. (45.7 cm)	75 lbs. (34 kg)

Terminals and Printers

# Configuring Information

## Hardcopy Terminals Configuring Information

Model	Mount	Watts, Btu/hr	Height	Width	Depth	Weight
LA12	Portable Tabletop	60, 188	14.4 cm 5.7 in	46.4 cm 18.3 in	39.4 cm 15.5 in	8.2 kg 18 lbs
LA50	Tabletop	180W	12.7 cm 5 in	39.8 cm 15.7 in	28.5 cm 11.2 in	9.1 kg 20 lbs
LA100	Tabletop Pedestal OPT	100, 188	17.8 cm 7 in	55.9 cm 22 in	39.4 cm 15.5 in	11.4 kg 25 lbs
LA120	Freestanding	153, 520	85.1 cm 33.5 in	69.9 cm 27.5 in	61 cm 24 in	46.3 kg 102 lbs
LQP02	Tabletop Pedestal OPT	120, 410	18.8 cm 7 in	63.5 cm 25 in	40.6 cm 16 in	21.8 kg 48 lbs

## Lineprinter Configuring Information

Model	Interface Mounting Code	DC/AC Amps Drawn @ +5VDC/ @120VAC	Bus Loads Drawn	Watts Btu/hr	Height	Width	Depth	Weight	Panel Units
LN01	1 Quad Slot	1.5/9.6	1	1,150 3,620	91.4 cm 36 in	65.5 cm 25.8 in	66 cm 26 in	136 kg 300 lbs	1
LP11-AA -BA	1 Quad Slot	1.5/3.0	1	350 1200	111 cm 43.8 in	85 cm 29.9 in	85 cm 33.5 in	89 kg 196 lbs	1
LP11-EA -EB	1 Quad Slot	1.5/4.5	1	475 1619	111 cm 43.8 in	76 cm 30.3 in	85 cm 33.6 in	93 kg 205 lbs	1
LP27-UA -UB	1 Quad Slot	1.5/9.2.0	1	1100 3600	124 cm 44.0 in	90 cm 35.5 in	98 cm 38.5 in	256 kg 567 lbs	1
LSP25-XX	1 Hex Slot	1.7/3.0	1	375 1200	111 cm 43.8 in	79 cm 31.1 in	85 cm 33.6 in	88 kg 195 lbs	1
LSP26-XX	1 Hex Slot	1.7/4.5	1	450 1619	111 cm 43.8 in	79 cm 31.1 in	85 cm 33.6 in	93 kg 205 lbs	1
LXY12-CA -CB	1 Quad Slot	1.5/4.0	1	450	118.1 cm	76.2 cm	61.6cm	90.7 kg	1
LXY22-CA -CB				1535	46.5 in	30 in	24.5 in	200 lbs	
LXY12-DA -DB	1 Quad Slot	None	None	450	118.1 cm	76.2 cm	61.6	90.7	1
LXY22-DA -DB				1535	46.5 in	30 in	24.5 in	200 lbs	1



# 7 Software

---

Software is the collection of written procedures and rules that control computer operations. The system software always includes an operating system, which is the "intelligence" of the computer system. Usually, the system software includes one or several language processors; it frequently includes specific applications as well.

As a set of organized programs, system software transforms your system hardware components into usable tools. These programs include operations, functions, and routines that assist you in solving problems and producing results. For example, some system programs store and retrieve data among the various peripheral devices. Others perform difficult or lengthy mathematical calculations. Some programs allow you to create, edit, and process application programs of your own. Still others handle entire applications for you.

The success of PDP-11 is built on the concept of architectural compatibility over the range of PDP-11 systems--from single-user systems in the business office to large systems that provide multiple services for universities or corporations. PDP-11 processors support multiple operating systems so that the proper hardware, operating system, and additional software can be combined to meet your specific application requirements, without altering the basic architectural compatibility of the system.

The high degree of compatibility among PDP-11 programming languages, system programs, and information management services makes it easy to interconnect your organization's operations. Digital's network products can link together realtime, timesharing, and single-user systems. While a few of the characteristics of software may vary from application to application, compatibility helps guarantee that programs can move among systems with a minimum of trouble. For example, the FORTRAN IV programming language runs on several operating systems. Consequently, a person who has learned it could, with little difficulty, write programs that would run in several operating system environments. Likewise, a FORTRAN IV application program can be readily transported to any Digital PDP-11 system that supports the FORTRAN IV language.

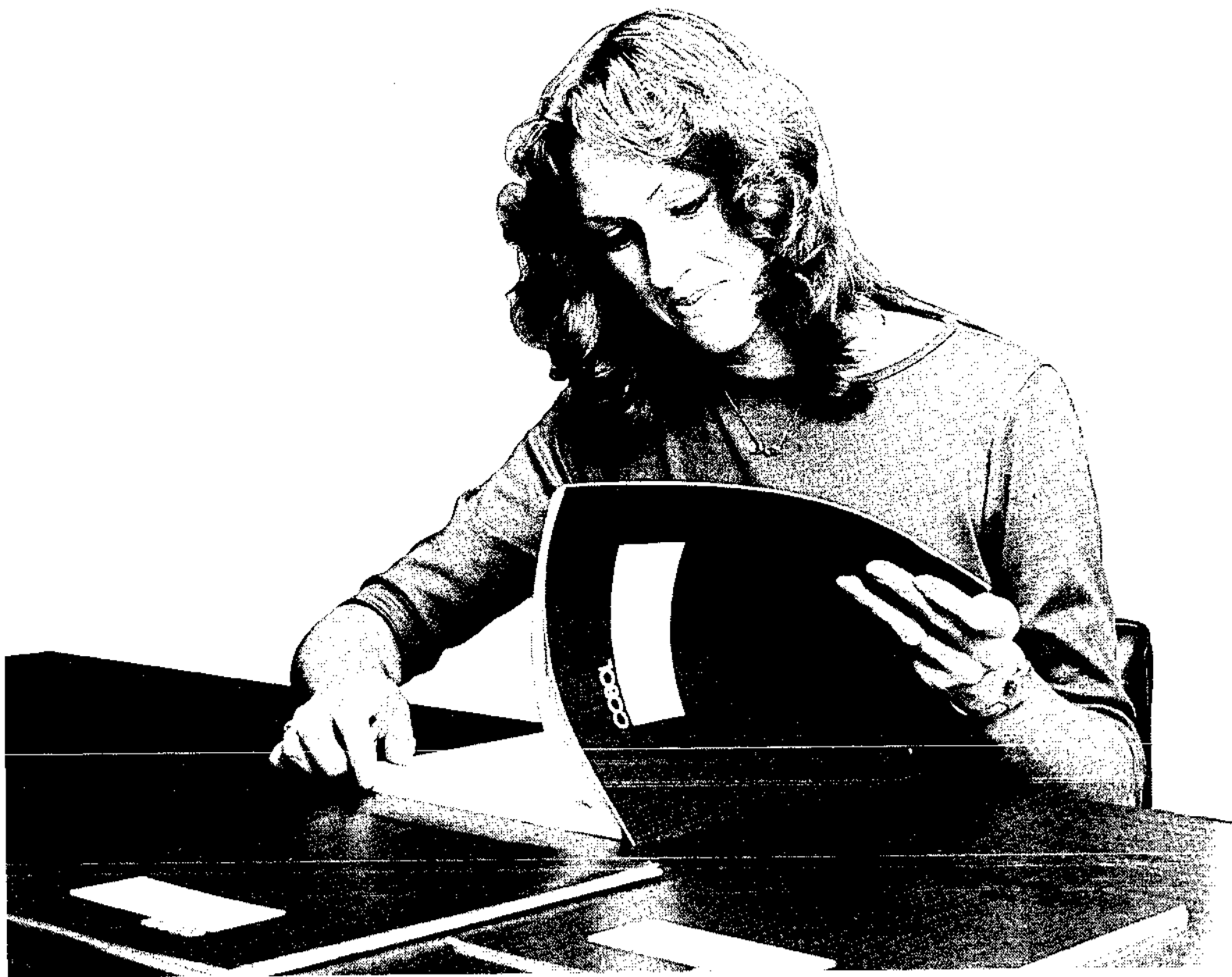

There is a wealth of languages, utilities, and application software packages for PDP-11s and the selection continues to grow. The PDP-11 Software Source Book contains listings of more than 12,000 application packages. Spanning a wide range of application areas, these programs are available from Digital and from commercial developers who specialize in writing program packages for PDP-11 operating systems.

Software available from Digital is reviewed in the section that follows. All PDP-11 operating systems and programming languages are described. Product descriptions of Digital software packages are presented, including packages for data management, word processing, graphics, and applications development.

# Software

---

## Software Selection Chart Operating System Software

Product	Description	Page
CTS-300	Extension of RT-11 for business applications	7-11
DSM-11	Multiuser timesharing for fast-access large-database applications on all PDP-11s	7-13
RSTS/E	General-purpose multiuser interactive timesharing for all PDP-11s	7-14
RSX-11M	Small-to-moderate size realtime multiprogramming system	7-15
RSX-11M-PLUS	Superset of RSX-11M for larger memories, more advanced processors	7-16
RSX-11S	Memory-resident execute-only downline-loadable subset of RSX-11M	7-16
RT-11	Small, single-user foreground/background system for realtime applications	7-10
UNIX	General-purpose multiuser interactive timesharing	7-12
Micro/RSX	Enhanced RSX-11M-PLUS subset, general purpose realtime, multiuser system for MICRO/PDP-11s	7-17

## Programming Languages

PDP-11 BASIC-PLUS-2	Block-structured interactive compiler for most DP applications	7-20
BASIC-11/RT-11	Interactive compiler for RT-11 systems	7-20
COBOL-81	Interactive compiler for business systems programming	7-21
CORAL-66	Block-structured language for realtime and process-control applications	7-21
DIBOL	Commercial applications language plus data entry screen formatting utility	7-21
FORTRAN IV	Compiled language for scientific applications, small memory environments	7-20
PDP-11 FORTRAN-77	Compiled language for file processing, scientific/engineering applications	7-20
PASCAL	Block-structured language for scientific/engineering applications	7-21



## Data Management Packages

<b>DATATRIEVE-11</b>	Interactive database query/report writing system for non-computer professionals	7-23
<b>FMS-11</b>	Digital's standard Forms Management application development package	7-23
<b>QUILL</b>	Query/sorting/report generation system for non-computer professionals	7-23
<b>SORT-11</b>	All-purpose data file sorting utility	7-23

## Word Processing

<b>DECtype</b>	Word-processing for CTS-300	7-24
<b>DECword/DP</b>	Word-processing for RSTS/E timesharing users	7-24

## Graphics Packages

<b>BCP</b>	Interactive package for printing bar codes and block letters on the LXY11/LXY22 Graphics Lineprinters	7-25
<b>DECgraph</b>	Interactive business graphics package for RSTS/E	7-25
<b>PLXY-11</b>	Graphics application development package for LXY11/LXY22 Graphics Lineprinters	7-24
<b>RGL</b>	Graphics package for RT-11 and RSX-11M	7-25
<b>VIGL</b>	Graphics subroutine for VS11	7-25

## Applications Development Packages

<b>ADE</b>	Tool for non-programmers to develop simple business applications	7-26
<b>MENU-11</b>	Package for creating customized menu-driven interfaces to RSTS/E systems	7-26
<b>MicroPower/Pascal</b>	Modular operating system for developing realtime microcomputer applications	7-17
<b>Professional Tool Kit</b>	Package for developing Professional 300 Personal Computer applications	7-26
<b>PROVUE</b>	Display control system for process monitoring	7-26
<b>RTEM</b>	RT emulator for RSX	7-26

# PDP-11 Operating Systems

---



An operating system is a collection of programs that manages a computer's hardware and software resources to provide efficient computer operation. The operating system organizes the central processor and its peripherals into useful tools for applications. Operating systems coordinate the execution of programs on the computer. They can also have a set of utilities and routines which manage resources such as printers and terminals, detect errors in programs, maintain user accounts, protect information, warn the operator of failures--and much more.

In general, an operating system is designed with a particular group of users in mind. Each operating system, therefore, acquires a unique set of characteristics reflecting the needs of such users. The basic distinction among PDP-11 operating systems is the processing method each system uses to execute tasks. The selection of an operating system(s) will reflect the following processing options:

- Single-user vs. multiuser
- Single-job vs. foreground/background
- Foreground/background vs. multiprogramming
- Timesharing vs. event-driven multiprogramming

A single-user operating system receives demands upon its resources from a single user at a time. It has only to manage the resources based on these demands. As a result, single-user systems do not require account numbers to access the system or data files. Nor do these systems usually provide protection for user programs. RT-11 is a single-user operating system.

# PDP-11 Operating Systems

---

A multiuser operating system receives demands for its resources from more than one individual and/or program. The system must manage its resources based on these demands. For example, several users may want sole control of a device at the same time. The system handles access to the device. In addition, because people may be using the system for different purposes, privacy must be an option. As a result, a multiuser system normally has an account system to manage different users' files. The RSTS/E, RSX-11M, and RSX-11M-PLUS systems are all multiuser systems.

The RT-11 operating system can operate in two modes: as a single-job system or as a foreground/background system. As a single-job system, one job at a time is executed in memory. As a foreground/background system, memory for user programs is divided into two separate regions. Two independent programs can reside in memory, one in the foreground region and one in the background region. The foreground region is occupied by a program requiring fast response to its demands and priority on all resources while it is processing. The foreground program executes until it relinquishes control to the background program. The background region is available for a low-priority program. The background program is allowed to execute until the foreground program again requires control. Thus, two programs effectively share the resources of the system.

The basis of foreground/background processing is the sharing of a system's resources between two tasks. An extension of foreground/background and multiuser processing is multiprogramming. In multiprogrammed processing, many jobs compete for the system's resources. The RSX-11 family of operating systems employs multiprogrammed processing based on a priority-ordered queue of programs demanding system resources. Memory is divided into several regions called partitions. All tasks loaded in the partitions can execute in parallel. Program execution, as in the RT-11 foreground/background system, is event-driven. A task retains control of the CPU until it is interrupted by a higher priority task or becomes unable to continue (for example, waiting for I/O or another resource). This family now includes MICRO/RSX, designed for use on the MICRO/PDP-11.

The RSTS/E and DSM systems also perform concurrent execution of many independent jobs. RSTS/E and DSM, however, process jobs on a timesharing rather than an event-driven basis. Timesharing is another type of multiprogramming. In a timesharing environment, each task is guaranteed a certain amount of CPU time. Jobs receive time one after another in a round-robin fashion. The system manages timesharing processing to obtain the best overall response, depending generally on whether jobs are compute-intensive or I/O intensive. This type of processing is particularly suited for an interactive processing environment.

Operating systems vary greatly in the kinds of hardware with which they are compatible, the range of complexity of tasks they handle, the degree of adaptability to special user purposes, and the programming languages which they support. PDP-11 computers run under a variety of operating systems. However, some applications run under only one operating system. Such applications require modification to run on other operating systems. Thus, it is important to consider what operating system(s) are required to use the desired applications.

The operating systems that run on PDP-11s offer various combinations of these processing environments. These systems are described in the following section.

# Ordering Information

Operating Systems Selection Chart

Selection Criteria	DSM-11	Micro Power/ Pascal	RSTS/E	RSX-11M	RSX-11M-PLUS	RSX-11S	RT-11	UNIX	Micro/RSX
<b>User Interface</b>									
DCL			STD	STD	STD		STD		STD
MCR				STD	STD	STD			
CCL			STD						STD
User-written				STD	STD				
<b>Text Editors</b>									
Key Pad			STD	STD	STD		STD		STD
Line	STD		STD	STD	STD		STD	STD	
<b>Batch Processing</b>			STD		STD		STD		STD
<b>File Management</b>									
Multi-key ISAM			STD	STD	STD				STD
Single-key ISAM			STD	STD	STD				STD
Sequential			STD	STD	STD		STD	STD	STD
Relative			STD	STD	STD		STD		STD
Random			STD	STD	STD		STD		STD
<b>Programming Languages</b>									
BASIC							OPT		
BASIC-PLUS			STD						
BASIC-PLUS-2			OPT	OPT	OPT				
C								STD	
COBOL-81			OPT	OPT	OPT				
CORAL 66				OPT	OPT				
DIBOL-11/DECFORM			OPT	OPT	OPT				
FORTRAN IV			OPT	OPT	OPT	OPT	OPT		
FORTRAN 77			OPT	OPT	OPT	OPT		STD	
MACRO-11 Assembler	STD	STD	STD		STD	STD			STD
MUMPS	STD								
PASCAL		STD		OPT	OPT				

# RT-11 Operating System

---

The RT-11 operating system is a disk-based, single-user, realtime operating system designed for interactive program development of online applications on UNIBUS- and Q-bus-based systems. Although it is a single-user system, RT-11 supports both single job (SJ) and foreground/background (FB) modes of processing, as well as a number of system jobs. In addition to a variety of system and program utilities, RT-11 supports a number of high-level language processors including BASIC-11 and FORTRAN IV.

The emphasis in RT-11 is on efficient use of system resources, minimizing system requirements in the CPU and on the mass storage devices, while maximizing system throughput. The RT-11 operating system offers the following configurations:

**SJ Monitor**—Enables one job at a time to execute in memory. As distributed, SJ resides in approximately 6 KB of memory and requires minimal overhead.

**FB Monitor**—Operates a foreground job and a background job. The realtime job is accomplished in the foreground, which generally has priority on system resources. Functions that do not have critical response time requirements, such as program development, are accomplished in the background, which operates whenever the foreground job cannot run. Within their priorities, both foreground and background are fully functional RT-11 programs with access to system capabilities. Although they operate independently, foreground and background can communicate through disk files and/or the message transmission facility.

**Extended Memory (XM) Monitor**—Version of the FB monitor for supporting systems with more than 64 KB of memory. The XM monitor is distributed, therefore, system generation is not required. This feature is accessible through those optional, high-level language processors that can automatically produce programs above 64 KB.

Some of the features of the RT-11 operating system include the following.

## Flexible Realtime I/O

Three modes of I/O operation are provided to satisfy a variety of input and output requirements. Synchronous I/O suspends user program processing until the completion of an I/O event. With asynchronous I/O, user program processing continues until a user-defined point is reached. Processing is then suspended until the I/O event is completed. Event-driven I/O allows user program processing to continue until the I/O event completes. Processing is then interrupted to service the completed I/O event.

## Indirect Command Files and Batch Processing

The indirect command file featured under RT-11 further simplifies user-system interaction. Users can construct indirect command files that contain strings of commonly issued keyboard monitor commands. By executing the indirect file, users can invoke the stream of commands. RT-11 also includes a batch facility for processing jobs at a later time without user intervention.

## Programming Tools

Program development tools offered within RT-11 include a choice of three text editors, file and device maintenance utilities, an online debugger, and a number of patch utilities. With DECnet-RT, Digital's advanced networking software, RT-11 systems can be linked with other Digital operating systems for network operation.

# CTS-300 Operating System

---

CTS-300 is a disk-based, single-user or multiuser software system that was designed to support commercial applications on smaller PDP-11s. CTS-300 applications are written in DIBOL, Digital's business-oriented high-level language. The system consists of the RT-11 operating system, a choice of three runtime systems, Single-User DIBOL (SUD), Time-Shared DIBOL (TSD), Extended Memory TSD, and a number of utilities. Depending on the applications, program development can be done in a timesharing environment that supports a number of users or jobs simultaneously.

Some of the capabilities provided on CTS-300 are described below.

## **Run-Time Systems (RTS)**

Single-user DIBOL allows one DIBOL user or job to be run on a system. It is designed for an entry-level system running in 32 KB of memory. SUD runs on all RT-11 monitors (SJ, FB, XM).

Time-Shared DIBOL allows one or two users or two to four jobs to run simultaneously. It is designed for a medium-sized system running in 56 KB of memory. File-sharing facilities at the record level permit users to share and update the same data files. TSD is an executive that is normally run on the SJ monitor generated for multiterminal support.

Extended memory TSD allows up to 12 DIBOL users or up to 16 DIBOL jobs to run simultaneously (up to 12 can be attached to terminals with the rest running in a detached environment). XMTSD is designed for larger systems running in 128 KB to 248 KB of memory. Using the XM monitor, XMTSD has the same features and capabilities found in TSD. In addition, XMTSD offers multiuser program development.

The CTS-300 programming editor, DKED, lets the user create and modify DIBOL programs online. Concurrent program development and application execution provide excellent flexibility. XMTSD runs in either the background or foreground. In the latter case, the background partition is available for program development.

## **Command Language**

CTS-300 is designed for interactive use with keyboard commands that are consistent in format and easy to understand. The high-level command language simplifies transition from source code to execution code, and also features indirect command files that permit the user to invoke a series of commands with a single command.

## **Data Management Services**

Data Management Services (DMS) for CTS-300 provide capabilities for handling sequential, random, or indexed sequential access method (ISAM) structured files. Multivolume file support permits one file, extending over several disk drives, to be processed sequentially or by keyed access, without requiring special programming.

# V7M-11 UNIX Operating System

V7M-11 UNIX is an enhanced, supported native UNIX based on AT&T's Standard Version 7 UNIX Timesharing System, Seventh Edition. It is a general purpose, interactive, time-sharing operating system that optimizes the programmer's skill rather than the instruction set of a machine. All of the features found in Version 7 UNIX are found in V7M-11. These include a hierarchical file system with demountable volumes, compatible file, device and interprocess I/O, asynchronous processes, a system command language selectable on a per-user basis, C compiler, and FORTRAN 77.

V7M-11 UNIX also has incorporated Version 3.7 of the VI full screen editor from Berkeley UNIX, and a modified version of the Berkeley User Overlay Scheme for large programs. Other enhancements include:

- Disk bad block replacement
- Fully automatic system generation
- System management commands
- Overlay kernel for use on CPUs without separate I and D space
- Crash dump analyzer

## V7M-11 UNIX Operating System Ordering Information

	Maximum 6 Users (MICRO/PDP-11 Only) QJ085-DZ	Maximum 9 Users QJ086-DZ	Maximum 16 Users QJ087-DZ	Maximum 32 Users QJ088-DZ
90 Day Warranty				
Media and Documentation Floppies RL02 Media Magnetic Tape (1800 B/N)	QJ085-A3	QJ086-AH QJ086-AM	QJ087-AH QJ087-AM	QJ088-AM
Documentation Set Only	QJ085-GZ	QJ086-GZ	QJ087-GZ	QJ088-GZ
Software Product Description (SPD) Number	16.51.xx	16.51.xx	16.51.xx	16.51.xx

# DSM-11 Operating System

---

The DSM-11 operating system is a multiuser data management system that consists of an interactive high-level programming language, Digital Standard MUMPS (Massachusetts General Hospital Multiprogramming System); a data management facility; and a timesharing executive.

Many users can access DSM-11 simultaneously and be relatively unaffected by the activities of other users. Because DSM-11 is an online program development and data storage and retrieval system, a programmer can rapidly write, test, debug, or modify a program and have a working application quickly established.

Digital Standard MUMPS, an extension of the American National Standard specification, is a high-level language oriented towards solving database problems. It can be used by programmers with relatively little programming experience. Implementation of the Digital Standard MUMPS language as an interpreter facilitates program development by eliminating the need to load editors, assemblers, and linkers.

The language's text-handling capabilities allow the inspection of any data item for content or for format. These capabilities are useful for online data entry checking and correction. Other text-handling capabilities include the ability to concatenate text strings and to segment text.

The DSM-11 hierarchical file structure allows users to design data file strategies to suit the needs of a particular processing environment. Dynamic file storage with variable length string subscripts allows for easy modification or expansion of the database.

Due to streamlined system installation and generation procedures, the DSM-11 system can be quickly adapted to any supported hardware configuration.

Other features of the DSM-11 operating system are:

- High-performance database handler using memory-resident cache of disk data for data sharing among users.
- Distributed database management implemented using DMC11/DMR11 high-speed data links.
- Online, high-speed database backup, disk media preparation and bad-block management, and tape-to-tape copying.
- Automatic powerfail-restart capability.
- Hardware device error reporting, system patching utility, and executive debugger for system maintenance.



# RSTS/E Operating System

---

The RSTS/E operating system is a multiuser, timesharing, and resource-sharing general purpose system. Its capabilities include batch processing, program development, and multiterminal applications. RSTS/E allows concurrent word processing and data processing and provides a highly productive and secure environment. As a timesharing system, RSTS/E provides excellent response time to users, who can number up to 127 at one time, and to jobs, which can number up to 63 at one time.

These additional features are offered on RSTS/E operating systems.

## Dynamic Allocation of System Resources

RSTS/E schedules CPU time and memory residency among jobs based upon their priority and processing requirements. A round-robin scheduling method is used to select jobs from those with equal priority. Systems with memory management can allocate enough address space for a job to run and can swap jobs out to disk storage when memory is needed for another job. A job's size can be expanded dynamically subject to the limits imposed by the system manager or another privileged user.

## Privilege Capabilities and System Operation

RSTS/E gives each user access to all system resources and peripherals unless otherwise restricted by the system manager or another privileged user. A privileged user has full access and control over system operations, including starting up and shutting down the system, adding or deleting user accounts, and designating certain programs as privileged.

## Batch Processing

Users can submit batch jobs to perform tasks that require no terminal interaction or to run programs at a later time. The user can specify the amount of CPU time for each batch job submitted and can specify termination conditions by requesting error-level checking.

## File System

The RSTS/E file system provides a variety of online capabilities. Files can be accessed randomly or sequentially, can be created, updated, extended, or deleted, and can be sorted by the SORT-11 program. File access can be limited on an individual, group, or system basis. Total or selective file backup and restoration can be done online.

RMS-11 is the main file and record access method available on RSTS/E. It supports sequential, relative, and indexed file organizations. With the indexed file organization each indexed file can have one primary key and up to 254 alternate keys. Indexed files are restricted to either a fixed or a variable record format.

RSTS/E disk volumes, when used as file-structured devices, can be either public or private. A public volume is the system disk or any volume-initialized public disk. All other volumes are designated private and can be used to limit user access and ensure greater system security.

RSTS/E can minimize accesses to disk for frequently used data by keeping data in a software-maintained cache, a specially designated area in system memory. The data retained in this cache can be restricted to disk directory blocks or can include data from disk files.

## User Interface

User commands are handled and interpreted by one of the runtime systems that acts as a command interface. The four standard command monitors are BASIC-PLUS, a single-language system; RSX, which provides MCR, the Monitor Console Routine; RT-11, providing RT-11 system commands; and the Digital Command Language, DCL. All of these interfaces interpret sets of system commands that enable the user to log on and off the system, manipulate files, develop and test programs, and obtain system information.

The Concise Command Language (CCL) feature allows each installation's system manager to define additional commands to run system utilities and user programs.

## Programming Tools

Program development is facilitated by a selection of system utilities and text editors, and can be done on the BASIC-PLUS, RSX, or RT-11 runtime systems. These environments provide an assembler, a linker or taskbuilder, and a librarian utility. The MACRO-11 Assembly Language provides full MACRO programming capabilities, including MACRO libraries, conditional assembly directives, and pseudo-operations. RSTS/E uses resident libraries for sharing of code that is common to more than one job.

# RSX-11M Operating System

---

The RSX-11M operating system is a multiuser, multiprogramming, realtime operating system designed for a variety of applications, including communications.

The event-driven and priority-structured scheduling mechanism allows the concurrent processing of realtime activities and less-time-critical tasks. The system has 250 software priority levels so a user can create, compile/assemble, debug, and install tasks without affecting realtime task response. When a high priority event occurs, tasks with lower priority are swapped out of memory so that higher priority tasks can be executed immediately.

RSX-11M is not only designed for a variety of applications, but also for many users. The account structure, maintained by the system manager, provides system users with their own unique User Identification Code (UIC), password, directory for files, and a set of privileges for access to system commands and resources. Thus, both experienced and new users are able to execute all necessary tasks without jeopardizing other's work on the system.

RSX-11M also contains a number of features that let the user generate a working system easily and rapidly. The Autoconfigure task automatically determines the correct hardware configuration (including the processor type, the CSR and vector addresses of the peripheral hardware devices, and any optional hardware present) for the system on which SYSGEN is running. The Standard Function System option produces a mapped RSX-11M operating system with the maximum number of software options, including support for layered products, thus eliminating the need for responding to a long list of questions.

The following briefly summarize other features offered on RSX-11M.

## **Choice of Command Interface**

All systems offer the traditional Monitor Console Routine (MCR) interface as well as the user-oriented, English-like Digital Command Language (DCL). Users also have the option to write their own Command Line Interpreters (CLIs) to suit their specific application.

## **Indirect Command Processor**

An indirect command file created by a terminal user, contains system commands that will be executed automatically by the system without further user intervention. Indirect command files save the user time and keystrokes by invoking repetitive or frequently used command procedures and system operations.

## **Programming Tools**

Tasks can be written in MACRO-11 assembly language and in the following optional languages: FORTRAN-77, FORTRAN IV, COBOL-81, BASIC-PLUS-2, DIBOL, PASCAL, and CORAL 66. Sharable system libraries and user-created libraries are supported for easy access to commonly used system routines. To assist in program development, RSX-11M includes both the EDI line-oriented and EDT character-oriented text editors, utilities, symbol cross-reference program, interactive debugger, and task memory dump facilities.

## **Data Management**

The RSX-11M file system provides automatic space allocation and file structures for all data on block-structured devices. Features include file protection, volume protection, and logical device assignments. Multiheader file support enables file size to be limited only by the capacity of the volume on which it resides.

The Record Management System (RMS) allows relative, sequential, and multikey indexed file organizations and random, sequential, and record address access mode.

## **Memory Management**

The RSX-11M executive can dynamically allocate available memory in system-controlled partitions. Effectively, this allows a task to be loaded anywhere in memory where there is room. When a task terminates, the space then becomes available for another task. Memory management provides the most efficient use of system memory and, therefore, faster task execution.

# RSX-11M-PLUS Operating System

---

RSX-11M-PLUS is a high-performance superset of the RSX-11M operating system, designed to take advantage of the expanded addressing capability of today's larger-memory PDP-11 processors. RSX-11M-PLUS maintains the superior reliability and successful architecture of RSX-11M to ensure compatibility and ease of transition between systems. This realtime, multiprogramming, multiuser operating system offers the same features as RSX-11M (see previous description) Plus the additional system capabilities described below.

## User Mode I/D Space

RSX-11M-PLUS supports separate instruction and data space. This means that a user task has the ability to address up to 64 KB of instruction and 64 KB of data simultaneously, giving a 128 KB total. I/D space simplifies the development and enhances performance of large application programs by reducing the need for program overlays.

## Multistream Batch Processing

A powerful batch processing facility is provided on RSX-11M-PLUS in addition to the indirect command file processing capability. Batch processing is a means of automatically passing commands and data for processing by means of a virtual terminal. Batch-specific commands, MCR and DCL commands, and data are placed in a file and submitted to the system for execution at a designated time (usually at night when there are fewer demands on the system). Batch jobs do not require the physical presence of a user nor do they require a physical terminal to run. Batch processing uses a virtual terminal that emulates a complete interactive terminal session from logging on to logging off.

## Accounting

For accounting purposes, the RSX-11M-PLUS system itself creates and maintains records on the use of system resources. These records are kept in an accounting log file. Accounting information is provided on users, the system, and every task running in the system. The system manager can use these accounting logs to establish programs for reporting on the use of system resources and for billing. Accounting also provides extensive performance information on mass storage devices.

# RSX-11S Operating System

---

The RSX-11S operating system is a memory-based subset of the RSX-11M operating system. It provides a runtime environment for execution of tasks on a memory-based processor. Memory-resident application programs require the support of a disk-based host system like RSX-11M, RSX-11M-PLUS, or VAX/VMS for program development.

RSX-11S has most of the RSX-11M features and generation capability, and supports all of the peripheral devices that are supported under RSX-11M.

RSX-11S includes:

- Monitor Console Routine
- Online Task Loader
- System Image Preservation Program
- File Control Services for record devices

# MICRO/R SX Operating System

---

MICRO/R SX is an extended subset of the multiuser, multi-task RSX-11M-PLUS operating system packaged on an RX50 mini-floppy disk. Although primarily designed for use with the MICRO/PDP-11, it also provides an ideal entry level multiuser development system for the PRO 300 series of personal computers. The newest member of the RSX-11 family, MICRO/R SX is a customer installed, easy-to-use system that can support up to ten users in both realtime and timesharing environments.

MICRO/R SX is divided into two separate packages. The Base Kit provides the full RSX-11-PLUS Executive, appropriate utilities and device drivers, support for user mode program development in high level languages, and a user documentation kit. The Advanced Programmer's Kit is an add-on to the base package and includes the software and documentation necessary for MACRO privileged mode program development. This includes a MACRO Assembler, a Librarian, and system libraries specifically designed for privileged mode programming.

## MicroPower/Pascal Operating System

---

MicroPower/Pascal is a modular operating system and software development package for microcomputer applications. It includes a high-performance optimizing Pascal compiler, a subset of the RT-11 operating system, and all the tools you need to create, build, test, and debug concurrent realtime application programs. The user can create these applications on a PDP-11 host system for execution on a different target microcomputer, which can be any Digital Q-bus or Extended Q-bus processor from the FALCON SBC-11/21 to the PDP-11/23-PLUS. Each application is constructed especially for its target system, with the exact set of operating system services needed.

MicroPower/Pascal is particularly suited for such dedicated, realtime microcomputer applications as process control, instrumentation, and robotics. An optimizing compiler produces fast, compact object code compatible with any Digital microcomputer. MicroPower/Pascal includes the following features.

### Two- Processor Development Environment

MicroPower/Pascal uses a two-processor development environment: a host PDP-11 running the RT-11 extended memory (XM) operating system, where the Pascal compiler and development utilities reside and execute, and a target Q-bus PDP-11, where the application program resides and executes. This provides the most effective work environment for developing target-system programs. A user can transport the final application program to the target microcomputer by one of three methods: writing it into read-only memory (ROM), down-line loading it over a serial line, or recording it on a floppy disk or tape cartridge to be bootstrapped on the target system.

### Concurrent Execution Capability

Concurrent execution means the Pascal source code is structured into independent parts called processes, which appear to execute simultaneously. Each process cooperates with all other processes in manipulating such shared resources as memory and peripheral devices.

### Customized System Routines

A modular runtime system software package that includes a library of executive service modules (modular operating system) is one of the major components of MicroPower/Pascal. By selecting only the appropriate components of the MicroPower/Pascal Runtime System software, and merging it with suitable user-written software, users can create a highly streamlined software package for their applications. This application software can run stand-alone on the target runtime system; no other operating system is needed. MicroPower/Pascal automatically selects those operating system services the application requires from a library in the PDP-11 host computer and places them in an executive module. By including only required system services, the module and the application it supports make the most efficient use of the target runtime system hardware. Furthermore, the modular runtime system is removable, which eliminates the need for mass storage in the target system.

**Note:** For ordering information, consult the SPD for MicroPower/Pascal (19.12.xx).

# Ordering Information

## PDP-11 Operating System Ordering Information

	CTS-300	DSM-11	MicroPower/ Pascal	RSTS/E	RSX-11M	RSX-11M -PLUS	RSX-11S	RT-11	Micro/R SX
<b>Support</b>	QJ354-AZ	QJ821-AZ	QJ029-AZ	QR430-AZ	QJ628-AZ	QR500-AZ	QJ628-AZ	QJ013-AZ	
<b>Training Credits</b>	None	4 TC	None	None	3 TC	3 TC	3 TC	None	None
<b>Media and Doc</b>									
<b>Disk</b>	QJ354-HH	QJ821-HH	QJ029-HH	QR430-HH	QJ738-HH	QR503-HH	QJ642-HH	QJ013-HH	QY800-H3
<b>Tape</b>	N/A	QJ821-HM	N/A	QR430-HM	QJ676-HM	QR500-HM	QJ642-HM	N/A	QY801-H3 (RX50)
<b>Doc Only</b>	QJ354-GZ	QJ821-GZ	QJ029-GZ	QR430-GZ	QJ628-GZ	QR500-GZ	QJ642-GZ	QJ013-GZ	QY800-GZ QY801-GZ
<b>SPD Number</b>	12.9.xx	12.18.xx	19.12.xx	13.1.xx	14.35.xx	14.70.xx	9.21.xx	12.1.xx	14.28.xx

### PDP-11 Operating System General License

The PDP-11 Operating System General License is a package of license-only (DZ) options for seven PDP-11 Operating Systems. RT-11, CTS-300, RSX-11S, RSX-11M, RSX-11M-PLUS, RSTS/E, and DSM-11. MicroPower/Pascal and UNIX are not included. This license is a 'right to copy' license and a customer must purchase (or have previously purchased) a supported license for the operating system that is desired for copy and use.

Because it is a package, the customer has the right to copy all or any part of the package. For example: customers could choose to copy only RSTS/E if all they wanted to run was RSTS/E; or if they were using both RSTS/E and RSX-11M PLUS, they could copy both. The general license package gives the customer the right to copy those operating systems and install them on only one additional CPU, just the same as all other license-only options.

Refer to the Operating System Software Product Descriptions (SPDs) to determine the suitability of the systems in this section for your intended application. In particular, compliance with the stated hardware requirements in the SPD is a prerequisite for Installation and Warranty Period Services.

### TRANSFERRING SOFTWARE TO MICRO/PDP-11

The removable media on a basic MICRO/PDP-11 system is the RX50 diskette. If there is a requirement to transfer software between another PDP-11 (or VAX) and the MICRO/PDP-11 - as, for example, in transporting applications from the host to the target system - one of the optional mass storage devices must be present on both systems.

It is expected that the majority of application developers, such as OEM's and DP departments of large organizations, will retain an in-house MICRO/PDP-11 to check out their application and support the target systems. In such cases, the in-house MICRO/PDP-11 is the only one that need have common media with the host development system. Transfer of the application from the in-house MICRO/PDP-11 to the target system could then be effected via RX50 diskettes.

# Languages and Applications

---

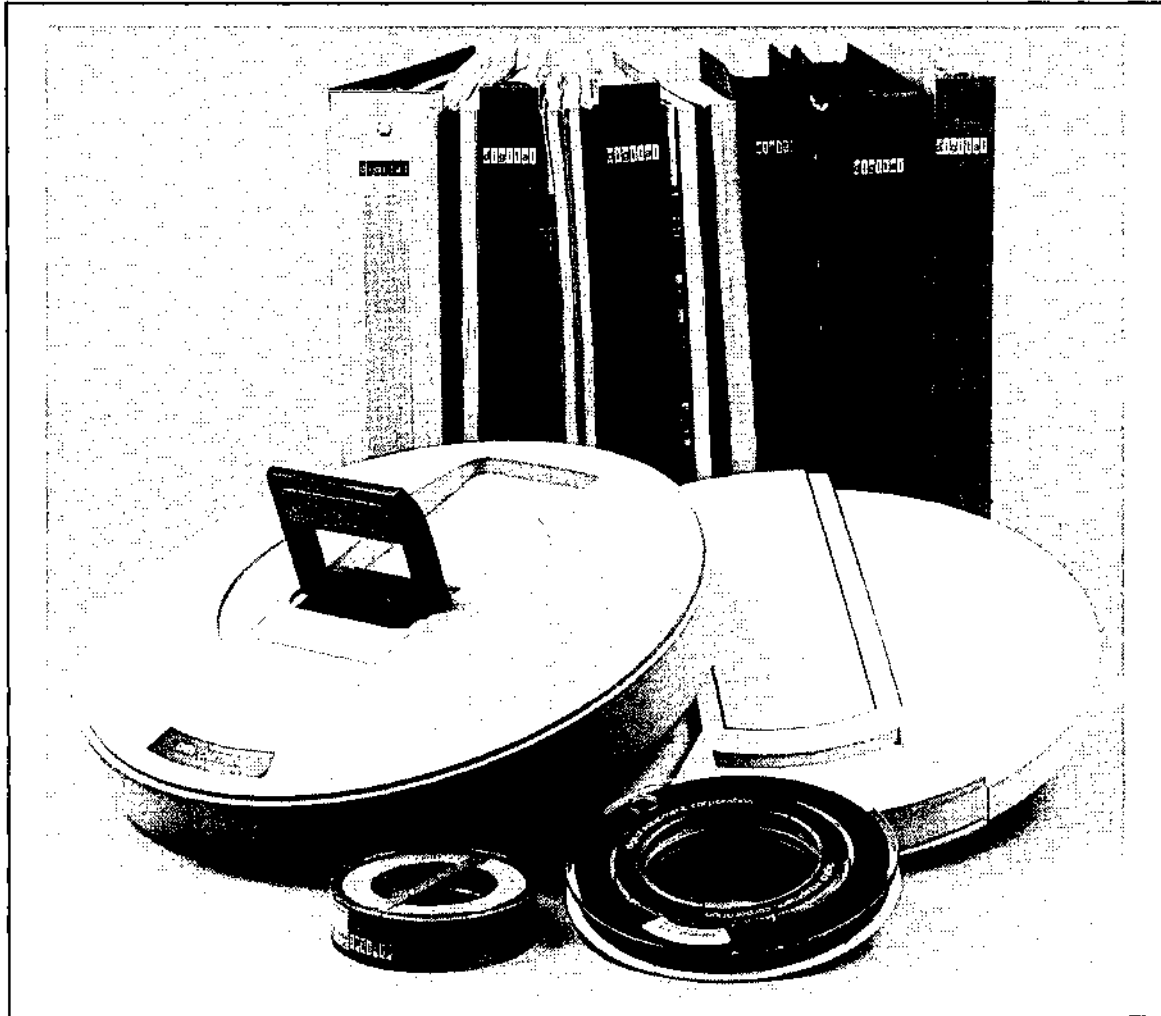

## Additional Software for Digital Operating Systems

Most operating systems need additional software, such as programming languages and applications packages, to perform more specialized tasks than the operating system can perform alone. PDP-11 programming languages and applications are well-suited to the needs of industry, science, academia, and business. There is a wide range of languages and applications available on PDP-11 operating systems to meet all programming needs—from system software development to general purpose application program development. When choosing a language or application package, various criteria can be evaluated based on individual needs and constraints. Among these criteria are relative performance, ease-of-use, price, portability, complexity, as well as specific functionality.

Some PDP-11 application packages are designed to give users with little computer familiarity the tools to perform specific tasks. The DECword/DP word processing package and the DATATRIEVE-11 query and report system are examples of such specialized packages. Other application products are designed for professional programmers to create new software for a much wider range of tasks. The programming languages and packages such as FMS-11 and the Professional Host Tool Kit fall into this category.

Programming languages have typically developed in response to specific functional needs. Some languages, such as FORTRAN were originally intended for processing enormous amounts of numerical data through complicated formulas at high speeds. Others, such as COBOL, were developed for commercial applications in which data management played a major role. And still others, like BASIC, were invented for used by students who were unfamiliar with computers and needed a simple, easy-to-learn language related to everyday speech. While some of these distinctions have become blurred over time, it is still true that certain kinds of problems are best approached through specific languages. The descriptions in this section attempt to show the special strengths of each Digital-supplied language in satisfying specific application needs.

With an appropriate selection of languages and applications packages, the PDP-11 system can satisfy the computer needs of users of multiple levels of expertise and function.

## PDP-11 BASIC-PLUS-2

PDP-11 BASIC-PLUS-2 is a high-level software implementation language derived from the original Dartmouth BASIC. Like the original, BASIC-PLUS-2 is a highly approachable language, with an interactive user interface, online help text, and simple English-like language elements. Unlike many other BASICs, though, BASIC-PLUS-2 is a compiled language with modern block-structured programming constructs, sophisticated file access methods, and a host of program development tools aimed at increasing programmer productivity. This combination makes BASIC-PLUS-2 practical for a wide range of uses, from developing data processing applications to training new programmers. Also, since BASIC-PLUS-2 is a close subset of VAX-11 BASIC, the two languages can be used together in projects with a mix of PDP-11 and VAX systems.

BASIC-PLUS-2 provides sequential, relative, indexed, and record file address (RFA) file access via the RMS Record Management System. Other features include a RUN command that allows immediate compilation and execution of the program currently in memory; a LOAD command that places previously compiled BASIC-PLUS-2 modules in memory for use by RUN; immediate-mode program debugging statements; the ability to omit line numbers and use mnemonic statement labels; and 31-character variable and constant names.

## BASIC-11/RT-11

BASIC-11/RT-11 is a conversational programming language that uses simple English-like statements and familiar mathematical notations to perform operations. It provides an interactive programming environment specially adapted for the RT-11 operating system.

BASIC-11/RT-11 is an incremental interpretive compiler with the following features: support for real, single- and double-precision, integer, and string data types; immediate-mode statements for debugging and desk calculator usage; sequential data storage using the RT-11 file system; string manipulation capabilities, including string arrays and functions; disk virtual arrays for string, integer, and real data types; chaining with COMMON to accommodate large programs; a CALL facility for invoking assembly language subroutines; and formatted output using the PRINT USING statement.

## PDP-11 FORTRAN-77

PDP-11 FORTRAN-77 is much more than just a scientific and engineering language. It combines the efficient numerical computation for which FORTRAN is known with provisions for keyed and sequential access to RMS multikey ISAM files. This makes FORTRAN-77 ideal for writing programs that must manipulate and perform calculations on masses of data, as in accounting or statistical packages.

FORTRAN-77 is built on the ANSI subset FORTRAN-77 X3.9-1978 standard, with the following extensions: TYPE and ACCEPT input/output statements; the BYTE data type; hexadecimal and octal constants; virtual memory arrays (on systems equipped with memory management); and language elements to perform RMS multikey ISAM. To use RMS-style elements, FORTRAN-77 programs make use of the RMS Object Time System (OTS); a File Control Services OTS is also available. The compiler produces direct PDP-11 machine code optimized for execution-time efficiency, especially when executed on systems equipped with a floating point processor.

## FORTRAN IV

FORTRAN IV is an extended superset of the ANSI X3.9-1966 standard for this scientific and engineering programming language. Its high-speed, one-pass optimizing compiler works very efficiently in small-memory environments, making FORTRAN program development possible on smaller PDP-11 systems. Because it can produce absolute binary code suitable for stand-alone PDP-11 systems or for loading into ROM or PROM memory, Digital's FORTRAN IV is especially useful for such industrial applications as control programs for automated equipment.

Other features of FORTRAN IV include the ability to use general expressions in all meaningful contexts; mixed-mode arithmetic; the BYTE data type for character manipulation; commenting at the end of each source line; and list-directed input/output.

# Programming Languages

---

## COBOL-81

The COBOL-81 language processor is an interactive high-performance compiler designed for PDP-11 business systems programming where ANSI-74 standard COBOL features, compact code, and low memory usage are of prime consideration. COBOL-81 shares a great deal of common syntax with VAX-11 COBOL. In most cases, programs written in COBOL-81 can be compiled and executed using the VAX-11 COBOL compiler without source-code changes.

COBOL-81 runs on the full range of PDP-11 systems. It lets users begin with the smallest PDP-11 system and grow to the largest VAX systems. The compiler takes full advantage of the PDP-11's optional Commercial Instruction Set (CIS) to generate even more efficient object code. The compiler's extensive library facilities and interactive Symbolic Debugger help increase programmer productivity and enable the production of powerful application programs.

## DIBOL-11/DECFORM

DIBOL-11, Digital's Business-Oriented Language, is a high-level language for commercial applications programming. It is similar to COBOL in that it has a DATA DIVISION, a PROCEDURE DIVISION, and uses English-like procedural statements (although more concise than those of COBOL). Unlike COBOL, DIBOL-11 is designed specifically for creating interactive applications programs.

DECFORM, a powerful, easy-to-use data entry and file inquiry package, is included with DIBOL-11 for designing screen formats for data entry. Using interactive video terminals, programmers can produce forms on the terminal screen that closely resemble traditional printed forms. Thus DIBOL-11 and DECFORM work together to help programmers who are designing applications in data entry and retrieval (such as accounting).

Both DIBOL-11 and DECFORM have their own interactive debugging utilities to speed program development. DIBOL-11 performs data manipulation, arithmetic expression evaluation, table subscripting, record redefinition, external calls to other programs, and both sequential and random access to files. DECFORM features facilities for defining data entry field protection, autoduplication, alphabetic or decimal checking, range checking, field totaling, crossfield validation, and autoincrement of counters.

## PDP-11 PASCAL/R SX

PDP-11 PASCAL/R SX is a high-level language for developing business, manufacturing, research, and education programs. Its English-like commands, logical grammar, and block structure help developers produce programs that have clear organization and linear flow.

PASCAL/R SX includes the features of the Level 0 ISO Specification for Computer Programming Language PASCAL (Draft Proposal 7185), plus many powerful extensions to the basic PASCAL language. PDP-11 PASCAL/R SX runs on all RSX-11M and RSX-11M-PLUS-based PDP-11 systems that have the Extended Instruction Set (EIS). PASCAL/R SX has sequential or direct record access, plus fixed or variable-length records.

## CORAL-66

CORAL-66 is the standard general purpose language prescribed by the British government for realtime and process-control applications. A high-level block-structured language, it replaces assembly-level programming in modern industrial and commercial applications. It is particularly useful for building software products that are expected to be long-lived and that require flexibility and easy maintenance.

Features of CORAL-66 include BYTE, LONG (32-bit integer), and DOUBLE (64-bit floating-point) data types; reentrant code at the procedure level; generation of code executable on any valid RSX-11S operating system that includes the Extended Instruction Set (EIS); conditional compilation; English-language error messages at compile time and (optionally) at runtime; and a switchable option to select a target PDP-11 instruction set.



# Ordering Information

## Programming Languages Ordering Information

Product	Order Code (SPD Number)		
	RT-11	RSTS/E	RSX-11M/M-PLUS
PDP-11 BASIC-PLUS-2	—	QJ916-AM,AH QY916-AM,AH (14.54.xx)	QJ918-AM,AH QY918-AM,AH (14.11.xx)
BASIC-11/RT-11	QJ913-AM,AH (12.5.xx)	—	—
COBOL-81	—	QJ993-AM,AH QY993-AM,AH (13.16.xx)	QJ994-AM,AH QY994-AM,AH (14.26.xx)
CORAL-66	—	—	QP066-AM,AH RSX-11M only (14.56.xx)
DIBOL-11	—	QP528-AM,AH QY528-AM,AH (14.8.xx)	QP540-AM,AH QY540-AM,AH
FORTRAN IV	QJ813-AM,AH (12.10.xx)	QR435-AM,AH (12.41.xx)	QP230-AM,AH (14.63.xx)
PDP-11 FORTRAN-77	—	QR100-AM,AH QY100-AM,AH (14.49.xx)	QJ668-AM,AH QY668-AM,AH (14.31.xx)
PDP-11 PASCAL/RSX	—	—	QJ128-AM,AH QY128-AM,AH (14.18.xx)

Note: Order codes beginning with the letters QY designate software for use on Q-bus systems.

### Support Categories

PDP-11 BASIC-PLUS-2 and DIBOL-11/DECFORM are Digital-Supported/Digital -Installed products. CORAL-66 is Customer-Supported. All other programming languages listed above are Digital-Supported/Customer-Installed.

### Order Code Suffixes

The following sets of letters replace the "-XX" suffix in the above order codes to indicate the media on which the product will be shipped plus any additional products or services included:

-AM	Single-use licence, binaries on 9-track magtape (1600 b/in), documentation, and support services
-AH	Single-use licence, binaries on RLO2 disk cartridge, documentation, and support services
-AG	Single-use licence, binaries on TU58 DECTape II, documentation, and support services
-DZ	Single-use licence only; no binaries, no documentation, no support services
-GZ	Documentation-only kit

In general, products available for the RT-11 operating system can be ordered with the AH, AG, DZ, and GZ options. Products available for the other operating systems can be ordered with the AM, AH, DZ, and GZ options. Exceptions are noted where they occur.

### For Further Information

Consult the Software Product Descriptions (SPDs) for additional information on ordering options, and support details for each product.

# Data Management Packages

---

## FMS-11

FMS-11 (Forms Management System) is used by application programmers to build interactive screen-oriented data entry capabilities into their application programs. Used in conjunction with a standard programming language such as FORTRAN, COBOL-81, or BASIC-PLUS-2, FMS-11 can be used for any data entry application in which paper forms were traditionally used--inventory, payroll, bookkeeping, and patient admittance, for example. FMS-11 can aid productivity at all levels: program designers are spared the complexities of creating custom terminal interfaces to use special features of the VT100; program developers can debug and correct forms quickly with FMS-11's own forms-debugging and editing utilities; and the application's end-user gets an intelligent data-entry system that minimizes keystrokes and catches most common typing errors.

Components of the FMS-11 package are: the Form Editor for layout and modification of video forms on a VT100 screen; the Video Keypad Editor for general purpose text editing of standard ASCII files; the Form Utility for manipulation of FMS forms descriptions during debugging; the Form Driver for performing screen processing at application runtime; and, on RT-11, the Application Run-Time Supervisor for running application programs independently of programs running on other system terminals.

## DATATRIEVE-11

DATATRIEVE-11 is an interactive query, report-writing, and data maintenance system designed to put easy access to system databases in the hands of noncomputer professionals. It is loaded with online prompting, help, and tutorial features that help computer novices "do it themselves," relieving DP staff from long schedules of small projects. DATATRIEVE-11 is especially useful for users who make frequent and constantly-changing requests for data from a large, established database, such as business analysts and middle-level management. It can also be used to build and maintain small personal databases.

DATATRIEVE-11 uses the RMS-11 Record Management System to access data records in sequential, relative, or indexed files. Users can specify selective data retrieval, sorting, formatting, updating, and generation of printed reports. Frequently used sequences of commands can be stored in a data dictionary for later use and for sharing among other users. An Application Design Tool (ADT) interactively steps novice users through the process of creating domain and record definitions.

## SORT-11

SORT-11 is an efficient all-purpose data sorting utility for files formatted by the RMS-11 Record Management System. It is flexible enough to meet the wide range of sorting needs encountered in everyday system use, from simple reordering of a mailing list by name or ZIP code to sorting massive data sets. It is especially useful for programmers and system administrators in charge of accessing and maintaining RMS-11 databases.

SORT-11 can accept files containing binary, EBCDIC, or ASCII data, in sequential, relative, or indexed-sequential file formats. The user can select sorting by any key field, in either ascending or descending order, using any of four sorting processes: Record Sort, which manipulates records in their entirety; Tag Sort, which produces a reordered file by manipulating only the key position of each record; Address Routing Sort, which produces one file for the data and multiple address files that are used to access the data in the desired sequences; and Index Sort, which produces a separate index file that contains for each record its SORT key field and a pointer to the record's location in the data file.

## QUILL

QUILL is an easy-to-use layered software package designed to run on the CTS-300 operating system. With simple English-like commands, users can take advantage of its three output capabilities: terminal queries, report generation on a printer or disk, and list documents on DECType-300. QUILL's commands generate automatic output, in a format that can be reused, against current, up-to-date data.

QUILL uses Dictionaries to describe data files. These Dictionaries support CTS-300 fixed length sequential and ISAM file structures. Each physical field has a logical field name associated with it. The Dictionary structure also supports password and field protection, multiple Dictionaries for a single data file, overlaid fields, Dictionary identification from a relative Dictionary, and maintenance routines to create, modify, copy, delete, and print Dictionaries. Arithmetic, relational, or boolean expressions can be used with names in the Dictionary to locate records within a data file.

QUILL features ascending and descending sort of up to eight individual fields. Its default structure provides standard output formats. Capabilities for customized formats are available.

Interactive and batch modes of operation can be called by a menu. A help facility that can be tailored is also provided.

## DECword/DP

DECword/DP gives fully featured word processing to RSTS/E users. It can be run from any VT100 terminal on a RSTS/E system, and gives end-users the type of text-manipulation features usually associated with stand-alone word processors. DECword/DP is suitable for RSTS/E users who need to prepare occasional memos and short reports. For high-volume word processing, users' needs will be much better served by one of Digital's more specialized product—such as the DECmate II personal computer.

DECword/DP provides such industry-standard features as menu-driven function selection, cut and paste, forward and reverse scrolling, global search and replace, and automatic word wrap. It also offers a variety of advanced features: automatic footnoting, spelling-error detection, list processing, and computer-aided instruction for using its software.

## DECType

DECType is a full-featured word processing package designed to run on the CTS-300 and VMS operating systems, permitting concurrent word and data processing in a multiuser environment. DECType provides industry-standard features such as menu-driven operation, cut and paste, forward and reverse scrolling, search and replace, automatic word wrap, subscripts, superscripts, headers and footers.

In addition, DECType provides a basic four-function editor math utility, user-defined keys for predetermined repetitive operations, and abbreviation and paragraph libraries, as well as the ability to cancel an editing session without changing the document.

DECType gives the user full control of printers. Users can remove documents from the print queue, change the print priority of a document, view the list of documents in the queue and view the status of all defined printers.

# Graphics Packages

---

## PLXY-11 Graphics Package

PLXY-11 is a software package designed to provide RT-11, RSX-11M, RSX-11M-PLUS, and RSTS/E applications programmers access to the plotting capabilities of Digital's LXY12/LXY22 graphics lineprinters. Using the PLXY-11 graphics subroutines, programmers can create software that prints out representations of data in graphs and charts with clear alphanumeric labeling. This makes PLXY-11 useful for equipping scientific, engineering, statistical, and econometric application programs with graphics.

To use PLXY-11, the programmer writes FORTRAN programs that call the appropriate subroutines in the PLXY-11 library. These subroutines convert the program's graphics requests into a series of vectors stored in an intermediate file. This file is submitted to the PLXY-11 post-processing task, which converts its vector data into raster format suitable to the LXY12/LXY22 graphics lineprinters. The user then transfers this converted file to the printer/plotter via a standard file-transfer utility such as PIP, where it is printed out by the system LP11 lineprinter driver.

(**Note:** PLXY-11 is shipped with the LXY11 and LXY21 lineprinter/plotters. To order, use the option numbers given in the Printer/Plotter Ordering Information.)

- |     |   |
|-----|---|
| -DZ | Single-use licence only; no binaries, no documentation, no support services |
| -GZ | Documentation-only kit  |

In general, products available for the RT-11 operating system can be ordered with the AH, DZ, and GZ options. Products available for the other operating systems can be ordered with the AM, AH, DZ, and GZ options. Exceptions are noted where they occur.

## For Further Information

Consult the Software Product Descriptions (SPDs) for additional information on ordering options, and support details for each product.

# Graphics Packages

---

## DECgraph-11

DECgraph-11 is an interactive business graphics application for the RSTS/E environment. Through the use of illustrated menus, a non-technical user can easily input the data to be graphed, design the graph description, and combine the data and description to create a graph file for display on the terminal or printer. Because the data, design, and graph files are maintained independently, it is possible to use modified or new data with a previously designed graph, or to use the same data for a different type of graph.

DECgraph-11 uses the graphic capabilities of the VT125 and graphic mode printers. Graphic images can be represented in black and white formats with the use of selected fill and line patterns.

Another feature of DECgraph-11 is a program interface, which allows it to be integrated with other applications. For example, it could be integrated with DATATRIEVE-11 to provide graphics output for DATATRIEVE-11 applications.

The prerequisites are any valid RSTS/E system with 400 free blocks of disk space and 28 KW of dedicated main memory; a VT125 video terminal with ROM version 102; an LA100, LA50, or LA12; and RMS support.

## RGL

RGL (ReGIS Graphics Library) is a set of FORTRAN subroutines providing full data plotting and flexible picture-drawing capabilities for the VT125 video terminal. The RGL subroutines are callable from any RT-11, RSX-11M, or VAX/VMS programming language (e.g., FORTRAN, BASIC, PASCAL) and support the ReGIS firmware included with the VT125 terminal. Picture-drawing features of RGL include user-defined multiple subscreens, shading, line patterns, writing modes, and picture objects such as boxes, arcs, circles, and regular polygons. RGL also provides a method for storing and later recalling screen images. Data plotting capabilities allow the user to define various types of graph "papers": linear, logarithmic, polar, or probability. RGL provides numeric and alphanumeric labeling and scaling of axes. The plotting subroutines are divided into static and dynamic segments. Static routines display all the user's data in one call. Dynamic routines allow point plotting (data added to a previously displayed "paper") and continuous display mode, where data can be scrolled left or right. RGL is Digital-supported and customer-installed.

## BCP Graphics Software

The BCP Bar Code/Block Character software package lets RSX-11M users print out industry-standard Code 39 bar codes, block characters, and vertical and horizontal lines and dashes on Digital's LXY12/LXY22 graphics lineprinters. The package provides quick and easy production of labels for warehouse, stockroom, and other inventory tracking operations.

The package's interactive user program lets users enter data to be coded for immediate printout of bar codes and block-lettered labels. A library of graphics routines are also provided that can be combined with applications programs written in PDP-11 FORTRAN-77, for fully automated label generation. Both parts of the package require that the RSX-11M system on which they run have FORTRAN-77 plus a minimum 40 KB of memory.

(Note: BCP is shipped with the LXY11 and LXY21 lineprinter/plotters. To order, use the RSX-11M option numbers given in the Printer/Plotter Ordering Information.)

## RSX-11M VIGL

RSX-11M VIGL is a library of FORTRAN callable graphic subroutines that provide the RSX-11M user with access to the graphic capabilities of the VS11/VSV11 graphics subsystem.

RSX-11M VIGL graphic facilities provided by the VIGL subroutine library allow the user to create FORTRAN applications programs. The subroutines convert graphics requests into display lists containing VS11/VSV11 specific graphic instructions and utilize the VS11/VSV11 Driver to send these display lists to the VS11/VSV11 graphic subsystem.

The minimum system requirements are any valid RSX-11M system configuration that includes VS11/VSV11 hardware, a minimum of 64K words of main memory in addition to that required by the operating system, and a minimum of 40,000 blocks of disk space. The prerequisite software is an RSX-11M Operating System with a VSV11-M Driver, and FORTRAN IV/IAS-RSX or PDP-11 FORTRAN-77/RXS. RSX-11M VIGL is Digital-supported and customer-installed.

# Applications Development Packages

## Professional Tool Kit

The Professional Tool Kit lets programmers use PDP-11 RSX-11M and RSX-11M-PLUS systems (as well as VAX/VMS systems) to develop application programs for Digital's Professional 300 Series Personal Computers. Using the software and optional hardware in the package, application programmers using their current PDP-11 systems can create and debug applications compatible with the Professional's P/OS menu-driven environment. This results in higher programmer productivity, less required training time, and preservation of current system investments. The Tool Kit is useful for software houses, DP departments, and other organizations that wish to produce applications using all the unique features of the Professionals.

The Tool Kit includes the MACRO-11/Professional, BASIC-PLUS-2/Professional, DIBOL/Professional, COBOL/Professional and FORTRAN-77/Professional programming languages; the RMS/Professional Record Management System; FMS/Professional for forms-oriented video I/O management; the SORT/Professional record sorting utility; the Professional Graphics Package for over 20 device-independent graphics commands; the Professional Diskette Builder for end-user media distribution; and the Professional Debugger for use with BASIC-PLUS-2/Professional. Applications are developed on the host PDP-11 system and then transferred to a Professional 350 system for debugging.

## ADE

ADE (Applications Development Environment), a programming tool specifically designed so nonprogrammers can develop and run small, simple applications for use in small businesses, allows users with little or no computer experience to perform such record keeping and bookkeeping tasks as maintaining and printing mailing lists, inventory lists, time sheets, and budgets. ADE runs in the RSTS/E timesharing environment.

ADE presents on a user's video terminal electronic worksheets made up of rows and columns. Users work with these worksheets by writing procedures—simple programs using English verbs. Procedures can store or retrieve information from worksheets in tables kept in disk files; manipulate the entries in a worksheet; or print out reports. An interactive help command, continuous display of available commands and messages at the bottom of the terminal screen, and interactive command prompting step users through using ADE.

## MENU-11

MENU-11 allows application programmers to design customized interfaces between a RSTS/E system and its users. RSTS/E's DCL command language environment can be sealed off from novice or infrequent users and replaced with a set of interactive menus backed by help texts. Programmers design the menus and help texts, giving users access to just those procedures and utilities needed in their work. This makes MENU-11 ideal for turning a RSTS/E system into a "turnkey" application system, as well as for providing security on a system with many inexperienced users.

MENU-11 consists of a set of programs that interact with RSTS/E and that control the display of menus to users according to prepared command files. The command files specify the format and content of menus; the help text associated with each menu option; the actions to be taken when an option is chosen (including conditional execution of actions); the transfers between different menus; and the interactions with the user to gather more information. Menu options can execute system commands, run application programs, and generally perform any action or series of actions that is possible under RSTS/E.

## PROVUE Color Graphics Display Management System

PROVUE is a powerful graphics display control system for use with PDP-11 computers. PROVUE surpasses conventional color display systems by performing all picture handling and display tasks internally, leaving the user free to concentrate on application software design. Created for process monitoring and control, and similar applications, the comprehensive PROVUE software performs dynamic picture update, displaying in real time the instantaneous state of the variables in the process being monitored. In addition, the system supports interactive dynamic alteration of the process variables.

A powerful on-line editor allows easy creation of mimics, graphics, character sets and special symbols, and provides the techniques to combine these into easy-to-understand formats displayable in sixteen discrete colors. Blinking may be used to highlight changing areas of the diagrams, alarm states, etc.

Depending on host computer size and configuration, up to five clusters of display stations can be supported, one local and four remote, and each cluster can consist of up to four display stations.

### Prerequisites:

<b>Local configuration</b>	VS11/VSV11 Graphics Display Station(s)
<b>Remote configuration</b>	PDP-11/23B cluster processor VS11/VSV11 Graphic Display Station(s) BA11-S expander box(es) Communications hardware High-speed DMR11, DMV11, BC55N, DLV11 Low-speed DZ11, DLV11, BC22

# Applications Development Packages

---

## **RTEM-11**

RTEM-11 provides the RT-11 program development environment on RSX-11M, RSX-11M-PLUS, and VAX/VMS. RTEM-11 runs in compatibility mode on VAX/VMS systems. It allows several users to develop RT-11 applications concurrently on a host system. The number of users is dependent on CPU power and system activity. Application programs can be created, edited, assembled, and linked on RTEM-11 and then executed on an RT-11 system. The minimum memory requirement for RSX-11M or RSX-11M-PLUS Systems is 48 KB.

### **Support Categories**

SORT-11 and DECword/DP are Digital-Supported/Digital-Installed products. The Professional Tool Kit and MENU-11 are Customer-Supported. All other programming languages listed above are Digital-Supported/Customer-Installed.

### **For Further Information**

Consult the Software Product Descriptions (SPDs) for additional information on ordering options, and support details for each product.

# Ordering Information

## Applications Packages Ordering Information

Order Code				
Product	RT-11	RSTS/E	RSX-11M/M-PLUS	CTS-300
ADE		QR530-AM,AH (13.11.xx)		
BCP	Note: To order BCP, see Sec. 6 under LXY Graphics Lineprinters.		(14.72.xx)	
DATATRIEVE-11		QP300-AM,AH QY300-AM,AH (12.48.xx)	QP301-AM,AH QY301-AM,AH (12.48.xx)	
DECgraph		QJA10-AM,AH (15.24.xx)		
DECType				QJ038-AH,-AX (13.15.xx)
DECWORD-DP		QR480-AM,AH (13.14.xx)		
FMS-11	QJ713-AM,AH (12.22.xx)	QJ716-AM,AH (13.17.xx)	QJ715-AM,AH (12.27.xx)	
MENU-11		QR690-CH,CM (12.60.xx)		
PLXY-11	(12.42.xx)	(14.16.xx)	(14.39.xx) (14.71.xx)	
Note: To order PLXY-11, see Sec. 6 under LXY Graphics Lineprinters.				
Professional Tool Kit			QJ071-AM,AH (40.2.xx)	
PROVUE			QJS83-XM,XH (14.33.xx) (RSX-11M only)	
QUILL				QJA09 (12.55.xx)
RGL	QJ122-AH (14.62.xx)		QJ123-AM,AH (14.62.xx) (RSX-11M only)	
RTEM			QJ291-AM,AH (30.21.xx)	
SORT-11			QP602-AM,AH (12.7.22)	
VIGL			QJS71-AX,DX (14.19.xx) (RSX-11M only)	

# Ordering Information

---

## Order Code Suffixes

The following suffixes in the above order codes indicate the media on which the product will be shipped plus any additional products or services included:

<b>-AM</b>	Single-use licence, binaries on <i>9-track magtape (1600 b/in)</i> , documentation, and support services
<b>-AH</b>	Single-use licence, binaries on <i>RL02 disk cartridge</i> , documentation, and support services
<b>-DZ</b>	Single-use license only; no binaries, no documentation, no support services
<b>-GZ</b>	Documentation-only kit

In general, products available for the RT-11 operating system can be ordered with the AH, DZ, and GZ options. Products available for the other operating systems can be ordered with the AM, AH, DZ, and GZ options. Exceptions are noted where they occur.

## RGL Software Plus VT125-AA

Distribution Media	RT-11	RSX-11M
9-track 800 b/in magtape	VT125-HD(JD)	VT125-LD(MD)
RK05 disk cartridge	VT125-HE(JE)	VT125-LE(ME)
RL02 disk cartridge	VT125-HH(JH)	VT125-LH(MH)
9-track 1600 b/in magtape		VT125-LM(MM)
RL01 disk cartridge	VT125-HQ(JQ)	VT125-LQ(MQ)
RX02 floppy diskette	VT125-HX(JX)	
RX01 floppy diskette	VT125-HY(JY)	



# Ordering Information

---

## RGL Software Plus VT100 to VT125 Upgrade or VT105 to VT125 Upgrade

Distribution Media	RT-11	RSX-11M
9-track 800 b/in magtape	VT1XX-HD	VT1XX-LD
RK05 disk cartridge	VT1XX-HE	VT1XX-LE
RL02 disk cartridge	VT1XX-HH	VT1XX-LH
9-track 600 b/in magtape		VT1XX-LM
RL01 disk cartridge	VT1XX-HQ	VT1XX-LQ
RX02 floppy diskette	VT1XX-HX	
RX01 floppy diskette	VT1XX-HY	

# DIGITAL'S Software Binary License Agreements

---

## Principles

Software is treated as proprietary information. Customers do not own it, but are licensed to use it under the terms and conditions of software license agreements. Key points of DIGITAL's software binary license agreements are:

- Customers must have a binary license to use any of DIGITAL's binary software products.
- This license allows **one** customer to run **one** software product on the CPU it is first installed on.
- DIGITAL retains title and ownership.
- DIGITAL's licensing agreement does not allow the transfer of software from one end user to another or from one CPU to another without prior permission from DIGITAL. Software may only be transferred to another party with written permission from DIGITAL.
- A customer may reproduce the software, if necessary, but only for use on the specific CPU licensed to use it.
- The use of an update version of the software on the licensed CPU requires that the customer purchase a software update option if out of warranty or not covered by a software service contract.
- The software may be used on another single CPU on a temporary basis during a malfunction of the original CPU which causes the software to be inoperable.
- Any modification to DIGITAL-licensed software doesn't exempt the software product from DIGITAL licensing or sublicensing terms, conditions, or fees. Only those modifications that are not part of the original software are the customer's property.

## Software Ordering Options

### DIGITAL-SUPPORTED Binary License Option

This is a standard binary license that includes media, manuals, documentation, and warranty packaged together. A 90-day warranty, as specified in the Software Product Description (SPD) Addendum, is the support received (unless different warranty conditions are specified in the SPD.) Main features of the warranty include: product updates, technical information, telephone support, and on-site remedial support. Depending on complexity, DIGITAL-supported products are designed as either DIGITAL-installed or Customer-installed.

#### DIGITAL-INSTALLED

DIGITAL provides installation services for products that are complex to install. Installation services include verification of complete product delivery and standard installation of the product. Hardware and the operating system are installed together.

#### CUSTOMER-INSTALLED

Since many DIGITAL-supported software products require no special skills to install, the customer can install these using the comprehensive, step-by-step documentation sets provided with them. The documentation sets detail all procedures necessary for proper installation. Once the software products have been installed, they too qualify for warranty service.

#### ADD-ON INSTALLATION FEE

With the exception of operating systems, customers who buy DIGITAL-Supported/DIGITAL-Installed products as add-ons after the original system is installed will be quoted an installation fee.

### CUSTOMER-SUPPORTED Binary License Option

This is a standard binary license which includes media, manuals, documentation but no warranty support. It is only offered when a DIGITAL-supported license option is not offered.

### LICENSE-ONLY Option

A license-only option is a standard binary license, but has no media, manuals, documentation or support. Software products can be ordered at considerable cost reduction, but the customer must first purchase a license with media for that particular software product. The license-only option is a one time right to copy. It is a license to run a single software product on one additional CPU using a copy of the software the customer made from the original licensed product. Customers may order additional copies of the documentation.

### OUT-OF-WARRANTY Update Option

A customer with a binary license may order a product update for each licensed CPU. An additional license fee is charged for each product update and for each one-time right to copy the update for each previously licensed CPU.

# PDP-11 Software Source Book-First Edition

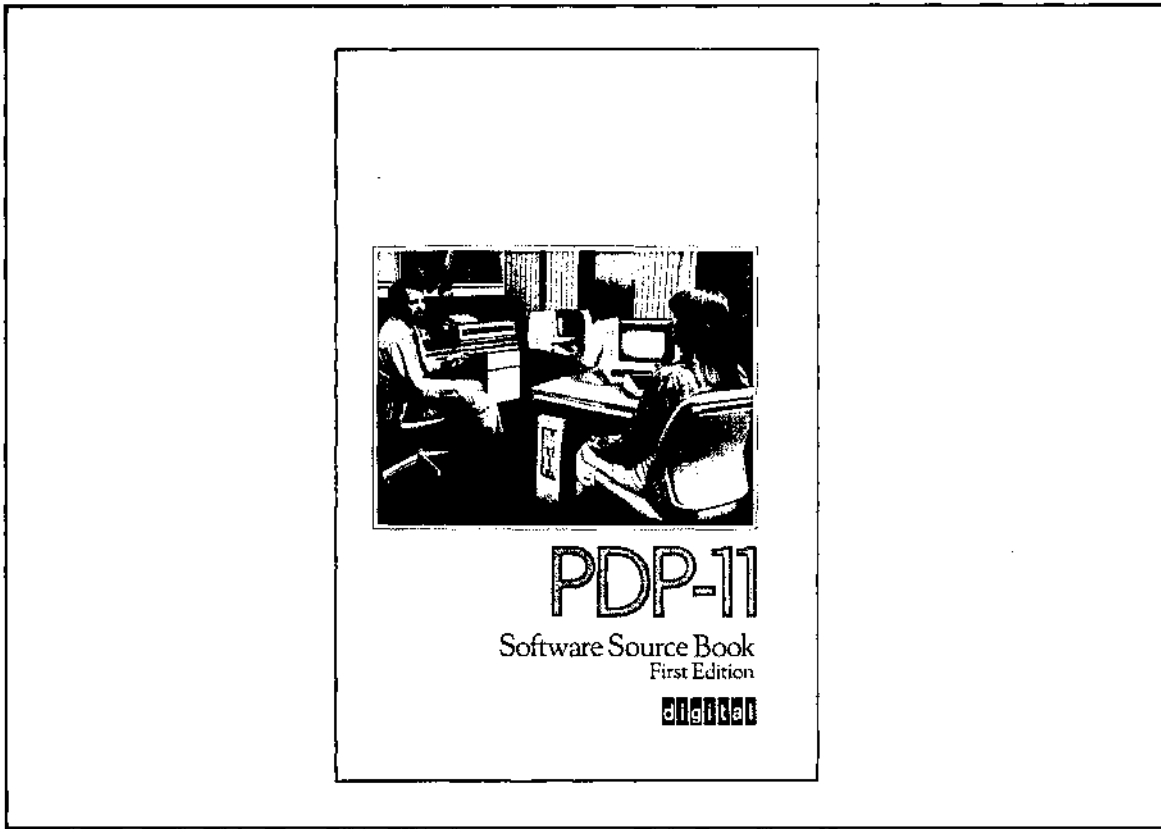

The PDP-11 computer family has hundreds of application software programs solving real problems today. What are those programs and how do you find the one you need? Find the answer in the first edition of the PDP-11 Software Source Book. It's available now and contains more than 1200 descriptions of application software currently running on PDP-11s. Sources of descriptions come from outside vendors, Digital, DECUS, and the EAS (External Application Software) Library.

The book is divided into three parts. Part I covers applications and groups software in categories such as Accounting and Finance (108 products), Manufacturing (52), Health Care (47), Office Systems (26), Education (69), and Engineering (93). Thirty categories of industries are included in Part I. Part II consists of three chapters that deal with systems software -- Language Processors, Operating Systems and Communications, and Software Tools and Utilities. Part III contains the cross-reference guides that make it easy for the user to find an application package to fit a particular need.

The PDP-11 Software Source Book is free and intended for the decision-making Digital customer and prospective customer of the PDP-11, including Micro/PDP-11. The book will be updated and published twice a year. The PDP-11 Software Source Book is available through your literature contact.



# 8 Networks

---

As organizations acquire more and more computers, the need arises for these computers to talk to one another. A computer network permits computers in different locations as well as computers built by different manufacturers to exchange information.

## **Digital Network Architecture**

The Digital Network Architecture (DNA), developed by Digital, defines an integrated set of networking capabilities. DNA supports a broad range of compatible networking options that can link realtime systems, timesharing systems, word processing systems, computational systems, and data processing systems together into one network. Such a network can increase productivity and can give an organization greater control over day-to-day operations. By speeding and organizing the flow of information in networks, management can help increase the efficiency of departments and the company as a whole.

DNA's breadth of capabilities is unique in the industry. The layered structure of DNA allows inclusion of a new communication technology, such as Ethernet, while preserving the application investment of Digital's customers. Today DNA Phase IV supports DDCMP (Digital Data Communications Message Protocol) for point-to-point and multipoint communications, Ethernet local area network protocols, and X.25 for communications over public packet-switching networks.



Local area networks (LANs) are networks that offer reliable high-speed communications channels, channels that are optimized for connecting information processing equipment in a limited geographic area—an office, a building, a complex of buildings, or campus for example. LANs are optimized for high-speed (greater than one million bits per second) data transfer. They are usually privately owned.

Ethernet is a local area network specification for communications protocols developed jointly by Xerox, Intel, and Digital. Digital's Ethernet program for local area networking extends the possibilities for effective communication and resource-sharing within the framework of DECnet. Digital has announced the availability of cables and cable interface connectors, transceivers, and communication controllers. The intent is to build other capabilities needed to link these networks with remote networks, public packet-switching networks, and SNA networks, all within the framework of the Digital Network Architecture.

## Communications Software

Digital's network software can be grouped in the following manner:

- DECnet for Digital-to-Digital system communication, either locally or remotely.
- Internets for connection of Digital systems to non-Digital systems.
- Packetnet for connection of systems utilizing a public packet-switching network.

When used in conjunction with the various communications hardware offerings, Digital's network software offers powerful capabilities for integrating an organization's operations, whether it be a manufacturing company, a university, an office, or an engineering application.

## Networking Selection Chart

Network	Software Communications Products	Page
DIGITAL-to-DIGITAL Host Communication  Local Traditional	All DECnet Layered Software DLX	8-4 8-5
Local Area Networks	DECnet-VAX DECnet-RSX-11M DECnet-RSX-11M-PLUS	8-4
Remote	All DECnet Layered Software DLX RSX-11 PSI VAX-11 PSI TOPS-20 PSI	8-4 8-5 8-9
DIGITAL-to-nonDIGITAL Host Communication	All Internets RSX-11 PSI VAX-11 PSI TOPS-20 PSI DECnet/SNA Gateway	8-7 8-10

# DECnet

---

DECnet is a family of software products that enable two or more Digital computer systems — the 16-bit PDP-11s, the 32-bit VAX computers, and the 36-bit DECsystem-10s and DECSYSTEM-20s — to form a network. At each node DECnet acts as an interface between the node's operating system and the network. Each operating system's DECnet software formats data and procedures according to a set of protocols described in the Digital Network Architecture (DNA) specifications. Each DECnet system then converts received data into formats for that operating system. The DNA specifications are nonproprietary and may be ordered from Digital's Accessories and Supplies Group (A&SG).

DECnet offers a wide range of networking functions over and above the data communications protocol which support a wide range of application strategies: occasional update of remote files using remote resource sharing facilities, and transfers of entire files from one system to another for intensive modification are just two of the features which may be selected to help optimize productivity. The following is a summary of DECnet's features:

- *Task-to-task communication* — enables two programs to exchange information. These two programs can be running under different operating systems, they can be written in different languages.
- *File transfer* — exchange of sequential ASCII or binary files; DECnet handles compatibility issues among operating systems. The transfer of filetypes other than sequential ASCII and binary may also be supported between particular operating systems. Check with your Digital Network Specialist for details.
- *Remote command file submission and execution* — one system can direct another to execute a specified program, either resident on the remote system, or sent to the remote system as a part of the request.
- *Downline loading* — programs or whole software systems can be developed on a node with the necessary peripherals and transferred to another node for execution to a small memory-only system, for example.
- *Network command terminal* — a terminal user physically connected to one system can logically connect to another system running the same operating system and act as if directly connected to that system.
- *Adaptive routing* — DECnet products communicate via a user-defined 'least cost' path and have the ability to detect and automatically route around line or system failures.
- *Network management* — Tools for monitoring and controlling network operation. These tools include facilities for tuning network parameters, for logging events, and for testing nodes, lines, modems, and communication interfaces. For monitoring network operation or for testing a new network application, DECnet provides statistical traffic and error information. Access to such network performance information allows potential problems to be solved before they degrade network performance.

## Configuring a DECnet Network

A DECnet network can be configured so that each network member is fully connected with every other member, or so that some nodes communicate with other network nodes through intermediate or routing nodes. Adaptive path routing means that the DECnet products in a routing network communicate via a user-defined "least cost" path, but can also detect and route around line or system failures.

DECnet nodes can communicate with adjacent nodes over synchronous and asynchronous communications lines and parallel interfaces. DECnet nodes can share a communication link in a multipoint configuration, thereby reducing the high cost of multiple, directly connected communications lines. Microwave and satellite links (neither is available from Digital) are also used to connect DECnet nodes.

DECnet-11M and DECnet-11M-PLUS (as well as DECnet-VAX and DECnet-20) nodes can communicate with each other with full DECnet functionality across a public packet-switching network when used with the Packetnet System Interface (PSI) products discussed later in this section.

The *Software Product Descriptions* (SPDs) should be consulted before ordering networking software and supporting hardware. Your local Software Services Network Specialist will also be of assistance in confirming that your proposed network configuration will meet your particular networking requirements.

## DECnet

DECnet is a Phase IV network product that allows a suitably configured system to participate as a routing or nonrouting (end) node in DECnet computer networks. DECnet offers task-to-task communications, utilities for network file transfer, homogeneous network command terminal support, and network resource capabilities, using the Digital Network Architecture (DNA) protocols. DECnet communicates with adjacent nodes over synchronous and asynchronous communication lines and parallel interfaces. Communication networks of over 1000 nodes are possible as is communication using the Ethernet specifications and protocols. Communication using X.25 circuits over selected public packet-switching networks is also possible when configured with the appropriate PSI product.

Consult the *Software Products Descriptions* (SPDs) for more information on each DECnet product. Each DECnet product offers its own level of functionality and its own set of features to the user. Users should also note that the functions available depend, in part, on the configuration of the rest of the network.

## DLX Software Interface

RSX DLX-11 is a low-overhead software communication line interface that provides users of Digital microcomputers access to Phase III DECnet networks. The product is available on the RSX-11M system for interfacing with a DECnet-11M or DECnet-11M-PLUS Phase III node.

RSX DLX-11 supports a single physical line in a point-to-point or multipoint connection. A user-written MACRO-11 program at each end of the line controls the communication line directly. The integrity and sequentiality of data sent over the line are maintained by the use of DECnet Digital Data Communication Message Protocol (DDCMP).

## DECnet Product Capabilities

CAPABILITY	DECnet PRODUCTS (SPD NUMBER)							
	-RT (10.72.xx)	-11M (10.75.xx)	-11S (10.74.xx)	-11M-PLUS (10.66.xx)	/E (10.73.xx)	-IAS (10.74.xx)	-VAX (25.3.xx)	-20 (23.2.xx)
PROGRAM-TO-PROGRAM	✓	✓	✓	✓	✓	✓	✓	✓
NETWORK COMMAND TERMINAL <sup>1</sup>	✓	✓	✓	✓	✓	✓	✓	✓
FILE TRANSFER	✓	✓	✓	✓	✓	✓	✓	✓
COMMAND/BATCH FILE SUBMISSION	✓ <sup>2</sup>	✓		✓	✓	✓	✓	✓ <sup>3</sup>
COMMAND/BATCH FILE EXECUTION	✓ <sup>2</sup>	✓	✓		✓	✓	✓	✓
REMOTE FILE ACCESS	✓	✓	✓ <sup>4</sup>	✓	✓	✓	✓	
DOWN-LINE SYSTEM LOADING		✓		✓		✓	✓	
DOWN-LINE TASK LOADING		✓		✓		✓	✓	

### NOTES:

- <sup>1</sup> Terminals on these systems can log onto other homogeneous systems in the network. DECnet-11S does not support connection from remote command terminals.
- <sup>2</sup> Requester-only function.
- <sup>3</sup> Server-only function.
- <sup>4</sup> Offers local users network access to remote file systems. Does not allow users on remote systems to access local files.



# Internets

---

The connection of Digital systems with computers built by other manufacturers is supported by a family of products called Internets. Digital's protocol emulator (PE) products provide a way for Digital computers and terminals to communicate with computers and terminals built by IBM, CDC, and UNIVAC by emulating those manufacturers' terminal and line protocols. Thus Digital's equipment appears to the equipment with which it communicates to be another supported device. Digital's wide range of Internet PEs gives you the freedom to choose mainframes and minicomputers on the basis of your application needs with the assurance that a reliable link can be established between these different systems.

Digital's Internet products are data transfer facilitators, not hardware emulators. They connect Digital computers with non-Digital systems, providing a means for interchanging data with IBM, UNIVAC, CDC, and other host processors. Digital's goal is to enable the exchange of data by using common communication protocols, not to provide plug-compatible replacements for terminal subsystems.

## Digital-to-IBM Communication

Digital offers a full range of Digital-to-IBM Internet products. These products aid users in implementing cross-vendor cooperative computing applications that span centralized and distributed processing environments. PDP-11 operating systems support program-to-program communication as well as 3270 terminal emulation and remote job entry (RJE). Installation, troubleshooting, and network-control facilities help minimize the problems of bringing up and maintaining effective internetwork operations.

### 2780, 3780, and HASP Protocol Emulators (Remote Job Entry BISYNC)

The RSTS/E 2780 Emulator emulates the communication protocol of an IBM 2780 device while running as a user job under a suitably configured UNIBUS-based RSTS/E system. It will transmit files from any input medium (video or hardcopy terminals, disks, tapes, and cardreaders) and receive files for any medium supported by RSTS/E. Files can print on any lineprinter supported by a RSTS/E operating system, excluding the LS11 printer.

The 2780/3780 PEs are BISYNC RJE emulators that allow files to be transferred between PDP-11 systems and IBM hosts supporting either the IBM 2780 or 3780 protocol. Multiple lines and multiple users are supported concurrently through operator and program control.

Dedicated or switched point-to-point lines can be used. Autoanswer is supported for switched lines. Operator control is performed using the standard Digital Command Language directives. Indirect command files can be used to minimize operator interaction or to facilitate completely unattended operation. Monitoring functions include continuously maintained traffic and error counters as well as on-demand status reporting. There are also troubleshooting facilities for loopback testing.

RSX-11M/IAS RJE/HASP performs the standard functions of an IBM HASP remote job entry workstation. Digital's HASP product mimics the CRT and keyboard of the HASP workstation by offering remote console support. In addition to using the features of the 2780 and 3780 emulators, the HASP PE user can communicate directly with the IBM mainframe from a local terminal to control and check the status of jobs on the IBM host.

RJE/HASP provides multileaved (pseudosimultaneous, bidirectional) communication of up to seven input and seven output data streams. Standard HASP protocol features include data compression of repeated sequential characters including blanks, full EBCDIC transparency, multileaving, and support of printer vertical forms to skip to channel 1 (top of form). Communication line control is performed directly by one of the RJE/HASP tasks. Concurrent use of the communications device by other RSX-11M or RSX-11M-PLUS tasks is precluded. Any mass storage or unit record device supported by RSX-11M or RSX-11M-PLUS can be used as a source or destination of data for a HASP data stream.

### 3271 Protocol Emulator (Interactive BISYNC)

The RSX-11 and RSTS/E 3271 Protocol Emulators provide facilities for both program-to-program interactive communication and data pass-through 3270 terminal emulation. The terminal emulator enables terminal users and application programs to exchange data with a program running under IMS or CICS on an IBM 370 or 303X host. The PDP-11 system appears to the host as an IBM 3277 Model 2 terminal and 3271 Model 2 control unit connected to a multidrop synchronous line. The PE module supports up to 6 synchronous lines (coresidency of RSX-11 3271 and either RSX-11 DECnet or RSX-11M/SNA PE is not supported).

## **RSX-11M/SNA Protocol Emulator**

The RSX-11M/SNA Protocol Emulator provides an RSX-11M system with the ability to participate in an IBM Systems Network Architecture (SNA) network. RSX-11M/SNA PE enables the RSX-11M user application programs to communicate with IBM application programs or system services on a task-to-task basis. Three modes of application programming support are offered to fit varied customer expertise and requirements: Emulator Control (EC), Extended Emulator Control (XEC), and Application Control (AC).

RSX-11M/SNA PE supports up to 4 half-duplex or full-duplex synchronous lines at speeds up to 9600 bits/second. The emulator will allow up to a maximum of 32 user sessions. The supported communications devices are DUP11 or KMC11 with DUP11s (coresidency with DECnet-11M or with RSX-11/3271 is not supported).

## **DECnet/SNA Gateway**

Through the DECnet/SNA Gateway, a network of Digital systems can share information with a network of IBM systems running under SNA.

With access routines for Remote Job Entry, 3270 Terminal Emulation, and/or the Application Program Interface, users of Digital systems in a DECnet network can access corporate-based information needed for departmental or divisional decision-making, transmit local data to a corporate database, and provide local access to applications available within the SNA network. Not only is the Gateway's operation transparent to the users in the DECnet environment, but as a shared network resource it eliminates the redundancy that would be necessary if each DECnet node communicated directly with the SNA network.

## **UNIVAC Protocol Emulator**

The UN1004/RSX/UNIVAC 1004 Terminal Emulator provides communication between a UNIBUS-based RSX-11M system and a UNIVAC 1100 series, or other system using the UNIVAC 1004 RMS-1 communications protocol. The software provides remote job entry (RJE) terminal emulation through which the user can send data in 80-column card format and receive data in line or card format. UN1004/RSX supports one synchronous communications circuit to a host computer, a single switched or dedicated lease line, two-wire or four-wire common carrier facility at transmission rates up to 4,800 bits per inch, and ASCII line communications code. Only full-duplex console terminals can act as emulator terminals.

## **MUX200 Multiterminal Emulator**

MUX200/RSX-IAS provides communication with a CDC 6000 CYBER series or other system using the 200 UT Mode 4A communications protocol. The PDP-11 user can communicate at command level with a host system, submitting jobs for batch processing and receiving results from the host. The software package can be configured to support either ASCII or external BCD versions of the communications protocol.

MUX200/RSX-IAS enables several users to communicate simultaneously with a host system over a single line. The PDP-11 system, while using a single physical drop, appears to the host as a number of multidrops and terminals on the circuit.

# Internets

---

The available Internet products are listed by SPD number. Consult DIGITAL's Software Product Descriptions (SPDs) for more information.

OPERATING SYSTEM	IBM 2780	IBM 3780	IBM HASP	IBM 3271	IBM SNA	UNIVAC UN1004	CDC MUX-200
RT-11	10.16.xx	10.16.xx					
CTS-300	10.16.xx	10.16.xx					
RSX-11M	10.1.xx	10.1.xx	10.51.xx	10.88.xx	14.4.xx	10.79.xx	10.77.xx
RSX-11M-PLUS	10.1.xx	10.1.xx		10.88.xx			
RSTS/E <sup>1</sup>	10.50.xx 10.49.xx	10.49.xx		10.83.xx			
VAX	27.7.xx	25.7.xx		25.21.xx	30.15.xx		15.2.xx
TOPS-10	30.23.xx 30.24.xx	30.23.xx 30.24.xx	30.24.xx				
TOPS-20	30.23.xx 30.24.xx	30.23.xx 30.24.xx	30.24.xx				

**NOTE:**

<sup>1</sup> Not available for use with PDP-11/23-PLUS systems.

# Packetnet System Interfaces

---

Communication costs are usually not of major concern when the network's computers are located at the same site. However, when you think about moving data between different locations, cities, or countries, communication costs become a major concern. Leased lines can be expensive and not all organizations have sufficient data communications traffic to warrant leased line costs. Dial-up lines are cost-effective for low volumes of data transfer, but with moderate data volume they become expensive as well. Public packet-switched networks (PPSNs) can provide the best features of both methods.

## PPSN Features

PPSNs offer the following advantages:

- Subscribers are permanently attached to the system via a leased line.
- The network guarantees a high level of end-to-end reliability.
- The network can compensate for the differences in transmission speeds between computers, and computers and terminals.
- The subscriber pays for the amount of data transmitted, not for the line itself.
- Data packets from different users are interleaved by the network, allowing for more efficient use of the PPSN line.
- Data packets can be routed along the first free line that becomes available. It is possible that the subcomponents of a message can be routed along completely different lines.

## X.25 Protocol Interface

X.25 is rapidly becoming an accepted international telecommunications protocol as it is adopted by more and more computer manufacturers. Any system on the network can send data to another system on the network. The PPSN provides dynamic routing and insures data integrity.

Digital's PSI products support both the basic multivendor functional transfer of data and a higher level of support for use between Digital systems across the network. Digital's PSI products have been designed and built to conform to the June 1980 CCITT LAPB specification. Programs can exchange data with other programs, and connections can be made over Permanent Virtual Circuits (PVCs) or Switched Virtual Circuits (SVCs).

## Interactive Terminal Interface

Digital's PSI products support access by remote terminals according to CCITT recommendations X.3 and X.28 through a network-supplied Packet Assembler/Disassembler (PAD) to the RSX-11 system. Remote terminal users have the same access privileges to RSX-11 programs as they would if they were local. Thus it is possible to run applications programs across a network with no modification, unless the network itself imposes restrictions which are beyond DIGITAL's control.

The PPSN guarantees data integrity across the network. Additionally, Digital's PSI products provide a subset of the Digital Network Architecture (DNA) specified Network Management functions. Network control programs are provided for loading and unloading the software, for defining the lines and network to which the system is connected, and for display of various network information, i.e., error counters and numbers of packets received and transmitted.

Use of RSX-11 PSI with DECnet-11M and DECnet-11M-PLUS allows packet-switched connections to be used as replacement for traditional leased or dial-up circuits in a portion of, or in all of, a DECnet network.

# Packetnet System Interfaces

---

## RSX-11 PSI

RSX-11 PSI/M and RSX-11 PSI/M-PLUS allow suitably configured RSX-11M and RSX-11M-PLUS systems to connect to public packet-switching networks (PPSNs) that conform to the CCITT recommendation of June 1980. These PSI products support task-to-task communication via the network, and remote terminal communication through a packet assembler/disassembler (PAD) facility provided by the network. Terminals connected to a host RSX-11M or RSX-11M-PLUS system cannot act as network terminals to other systems connected to the network.

Access to RSX-11 PSI/M or RSX-11 PSI/M-PLUS is supported for RSX-11M user programs written in MACRO-11, FORTRAN-IV, and FORTRAN-77. The communications discipline used is the CCITT V.24 (RS232-C) at the hardware level, the symmetric LAPB variant of the X.25 frame level protocol and the X.25 packet level protocol.

RSX-11 PSI/M and RSX-11 PSI/M-PLUS can coexist with, or operate as a layered product under DECnet-11M or DECnet-11M-PLUS, allowing the use of DECnet facilities over PPSNs as well as private leased-lines or switched telephone networks. The Packetnet System Interface supports a subset of DIGITAL's Network Architecture's management features including loading and unloading software, defining lines, and providing access to error counters and other maintenance functions.

RSX-11 PSI/M and RSX-11 PSI/M-PLUS have been certified and are warranted on the following networks: Transpac (France), Datex-P (Germany), PSS (United Kingdom), and Telenet (U.S.A.).

Data System	RSX-11 PSI	VAX-11 PSI	TOPS-20 PSI
	10.42.xx 10.43.xx	25.40.xx	21.22.xx
TELENET (U.S.)	✓	✓	✓
TYMNET (U.S.)		✓	
TRANSPAC (France)	✓	✓	✓
DATEX-P (Germany)	✓	✓	✓
PSS (U.K.)	✓	✓	
DATAPAC (Canada)		✓	
DATANET 1 (Holland)		✓	

# Ordering Information

## Communications Software Ordering Information

Communications Software	Order Code (SPD Number)			
	RSTS/E	RSX-11M	RSX-11M-PLUS	RT-11
DECnet	QP692 (10.73.xx)	QJ684 (10.75.xx)	QR580 (10.66.xx)	QJ687 (10.72.xx)
DLX-11 Software Interface		QJ689 (10.6.xx)		
MUX200/RSX-IAS Multiterminal Emulator		QJ070 (10.77.xx)		
RSTS/E-2780 Emulator	QPD10 (10.50.xx)			
RSX-11M/IAS RJE/HASP		QJS60 (10.51.xx)	QJS62 (10.51.xx)	
RSX-11M/SNA Protocol Emulator		QJD69 (14.4.xx)		
RSX-11 PSI		QJD91 (10.42.xx)	QJD92 (10.43.xx)	
UN1004 RSX/UNIVAC 1004 Terminal Emulator		QJ170 (10.79.xx)		
2780/3780 Protocol Emulators	QRD06 (10.49.xx)	QJD82 (10.1.xx)	QJD82 (10.1.xx)	QJD59 (10.16.xx)
3271 Protocol Emulators	QRD05 (10.83.xx)	QJD76 (10.88.xx)	QJD76 (10.88.xx)	

### Additional Information:

- Digital's PDP-11 networking software is offered on the following media:
  - AD indicates 2032 b/cm (800 b/in) 9-track magtape
  - AM indicates 4064 b/cm (1600 b/in) 9-track magtape
  - AH indicates RLO2 disk cartridge
  - AV indicates RK07 disk cartridge
  - AG indicates TU58 DECTape
- Support Category: Digital-supported/Digital-installed.
- License: Single-use license, binaries, documentation, support services for all media (-Ax extension in order code).
- Documentation-only Kit: Order with -GZ extension.
- License-only: For single-use license-only, no binaries, no documentation, no support services, order -DZ extension.

### Note:

Consult the *Software Product Descriptions* for more information on each product. The level of functionality for a group of communications software varies depending on the operating system.



## 9 Customer Services

---

One of the major advantages of owning a computer system from Digital Equipment Corporation is the extent of the customer services available. DIGITAL has hundreds of service centers located around the world as well as customer education centers in many major cities. However, this section highlights the major categories of service offerings available from DIGITAL's **Field Service**, **Educational Services**, and **Software Services** organizations.





## Hardware Services

Digital's Field Service organization offers a range of onsite and off-site post-warranty services. Over 16,000 Field Service personnel in more than 400 locations worldwide with an inventory of over \$500 million in parts are ready to provide the support needed for continuous productivity.

## On-Site Services

### DECservice

DECservice is Digital's most comprehensive on-site maintenance program for customers requiring uninterrupted system performance. This program provides a variety of services designed to ensure maximum system availability. Included in the agreement are provisions for:

- Digital's commitment to fast response
- Continuous remedial maintenance service
- Planned priority escalation
- Extended preventive maintenance scheduling
- All parts, materials, and labor
- Engineering modifications
- An assigned Service Representative
- A comprehensive Site Management Guide

### Basic Service

Digital's Basic Service is a comprehensive on-site maintenance program offering economy, attention to detail, and a wide range of maintenance services. Maximum system availability is ensured by these provisions:

- Complete remedial maintenance
- Planned preventive maintenance
- All parts, materials, and labor
- Assigned Service Representative
- Comprehensive Site Management Guide

Although standard coverage for both of these on-site service plans is 8 hours a day, 5 days a week, customers can opt to extend DECservice coverage to 12, 16, or 24 hours, including weekends and holidays.

### Shared Maintenance

Shared Maintenance is a cooperative support program for customers with in-house service staffs. The program backs up your service team with Digital's service representatives and network of resources. It ensures that Digital's support is there when you need it the most — when your system is down.

### Per Call Service

Per Call Service is offered to Digital's customers who wish to establish a non-contractual service alternative as either a primary maintenance program or an enhancement to a self-maintenance effort. Contract customers can also use Per Call Service as a supplementary service outside of contractual hours of coverage.

# Field Service

---

## Off-Site Services

### Digital Servicenter

The Digital Servicenter (DSC) is a carry-in repair center for Digital's Terminals and Small Systems offering low-cost repairs at over 145 convenient locations. At the DSC you receive the same quality service as you would at your office with a guaranteed two-day turnaround on your equipment. At the DSC you may choose from contract (fixed annual cost), per call (fixed labor charge plus parts), or parts exchange (pay only for the part you determine to be bad).

### Customer Returns Center

The Customer Returns Center (CRC) is dedicated to the off-site service needs of the self-maintenance customer. CRC provides service on a wide range of products, available through contractual and non-contractual agreements. In addition, the CRC honors the corporate return-to-factory warranty for all module types (excluding CSS) offered by Digital. The CRC's standard service offering is DECmailer.

### DECmailer

DECmailer is Digital's premium return-to-factory repair program. It provides qualified Digital customers with a fast, easy, economical way of handling module and subassembly repair. The program features:

- A fast 5-day turnaround time
- Repair of over 1100 parts

### Media Maintenance Service

Digital's Media Maintenance Service is a comprehensive program which provides total media maintenance service for your disk cartridges (RL01, RL02, RK05, RK06, RK07). The program provides:

- Inspection of all disk cartridges
- Thorough cleaning of all cartridges
- All cartridges are labeled
- Installation of SHOCKWATCH warning device
- Cartridge warranty for life of your Field Service contract
- Free replacement of defective cartridges which are under this program
- Reduced downtime, increased system performance

## Specialized Services To Protect Your Assets

### Records Management

At our specially designed, secured national sites, we will store your valuable media off-site while remaining available to you 7 days a week, 24 hours a day. We provide the most advanced facilities, equipment, security, and support available today.

### Educational Services, Disaster Planning, and Consultation

Through education planning and consultation, Digital helps assure your peace of mind should a disaster strike. We will consult with you, help you assess your need, and develop a contingency plan for system back-up. We will help you determine the kind of support you will need to make certain you do not lose time or money in the event of an emergency. We can also provide you with the direct support if you need it.

For further information on any of the aforementioned services, call toll free 1-800-DIGITAL.

SHOCKWATCH is a registered trademark of Media Recover.

# Software Services

---

Software Services are available to support PDP-11 customers during any aspect of their system analysis, software development, or implementation efforts. Services available start with the personal attention of a Digital software consultant and continue with the distribution of up-to-date software and software information.

A software specialist often works with a Digital sales representative to evaluate a prospective user's needs prior to purchase, recommend hardware/software solutions to problems, and give advice on the feasibility and costs of proposed solutions.

Depending on the software purchased, specialists are available to install software and provide software warranty support to assure that purchased software products perform according to Digital's commitments. Ongoing software support is assured through a variety of post-warranty Software Product Services, which offer customers the opportunity to keep their software up-to-date and running smoothly. A full range of Professional Software Services is available to assist customers throughout the planning, implementation, and production phases of their systems.

For those PDP-11 software products that require Digital installation, a software specialist will install the software and verify that the system is complete. Software warranty services include telephone assistance and on-site remedial support, if necessary. Services also include automatic delivery of in-warranty Software Product and Documentation Updates and the distribution of a periodic newsletter. Software Performance Reports are included under warranty services, as well.

## Software Product Services

Software Product Services (SPS) provide informational, preventive and remedial service to help customers after the period of software warranty. These services provide updates to the latest software products, responses to reported software problems, and technical publications that contain programming notes and documentation corrections.

The family of Software Product Services includes four levels of service: Software Product Updates, Self-Maintenance Service for Software, Basic Service for Software, and DECsupport Service for Software.

- **Software Product Updates** — Single major releases of software, including documentation. No services are included (however, they may be purchased at per-call rates).
- **Self-Maintenance Service for Software** — Tools are provided to enable users to maintain their own system software. These include Software Product and Documentation Updates, sent automatically as they are released; newsletters containing information about new software developments and enhancements; and Software Performance Reports, a formal software problem reporting mechanism.
- **Basic Service for Software** — This service is appropriate for users who require some, but not total, support. It includes all the elements of Self-Maintenance Service, plus telephone support for usage and remedial software questions.
- **DECsupport Service for Software** — The most comprehensive software product service available. DECsupport includes all the elements of Basic Service, plus preventive maintenance, delivery and installation of updates and Program Change Orders, and on-site remedial support for critical situations.

A License-to-Copy Update Option is also available. This option allows customers to copy Software Product Updates onto a single, additional CPU. It is suitable for customers who are running identical operating system software on several similar CPUs, and who want to copy the updates only.

## Professional Software Services

Digital's software professionals are specifically trained in Digital products and experienced in designing, coding and modifying custom software as well as tailoring PDP-11 software to meet special needs. Software specialists are available to provide system analysis, application design review and optimization, and system/application integration. Resources are available to perform specific project tasks, supplement a customer's programming staff, or manage projects from start to completion.

Varying types of expertise are available, ranging from programmer to project manager, depending on customer requirements. Professional services are available at both resident and per-call rates, and also on a fixed-price per project basis.

# Software Services

---

## DECstart Services

DECstart is a proven combination of direct assistance, documentation review, discussion and hands-on experience provided on site by a Digital Software Specialist.

Users learn directly on their own systems and can put their knowledge to use immediately. The DECstart services are conducted over a period of time to assure mastery of the system. Programmers and system managers are taken step-by-step through the techniques required to effectively operate a particular system. DECstart enhances the ability of users to keep their systems running smoothly by teaching them how to troubleshoot problems.

Digital's Software Services group meets customer needs by offering a wide range of options to supplement the standard DECstart package. Optional services are priced according to the time they require, therefore an estimate can be given for any requirement a customer may be considering. In addition, a Digital Software Specialist can draw up a Customer Support Plan to help the user determine any further areas in which he or she might benefit from additional services.

## PDP-11 Customer Training

Digital provides comprehensive educational programs to train your personnel before, during, and after installation. Instruction in system management, operations, hardware, and software is available in five formats:

- **Lecture/Lab Instruction**—Provides traditional classroom lectures and laboratory experiences at one of Digital's 26 Training Centers worldwide.
- **Self-paced Instruction(SPI)**—Self-Paced courses offer training materials that are portable, self-contained, and modular in format. They are educationally designed so that students can progress at their own learning rate. SPI courses are offered in three formats: **Print—Text** books or manuals; **Audio-Visual—Cassettes** and filmstrips; and **Computer-Based Instruction**—Taught on the computer, by the computer.
- **On-Site Training**—On-site courses can be adapted to cover your particular application or operational needs in depth. Every lecture course offered by Educational Services can also be taught at your job site.
- **Exclusive Courses**—If you have a unique application, Educational Services can create an exclusive course tailored to your needs.
- **Technical and Management Seminars**—Management seminars are specifically designed for non-technical personnel to help them better understand data processing and how to use its capabilities. Technical seminars are a series of state-of-the-art programs aimed at DP professionals and managers focusing on the newest applied technologies.

For further details regarding dates, times, locations, and costs, as well as information about training credits available to Digital customers, contact your nearest Digital Training Center or your Account Representative.



# Appendix A

**LSI-11 Option Conversion Table**

Old Option	Upgrade Option	System Option
DLV11 DLV11-E DLV11-EB DLV11-ED DLV11-EP	DLV11-M DLVE1-M DLVE1-M + CK-DLVE1-D* DLVE1-M + CK-DLVE1-D* DLVE1-M + CK-DLVE1-D*	DLV11-MP DLVE1-DP DLVE1-DP DLVE1-DP DLVE1-DP
DLV11-J DLV11-JA DLV11-JP	DLVJ1-M DLVJ1-M + CK-DLVJ1-L* DLVJ1-M + CK-DLVJ1-L*	None DLVJ1-LP DLVJ1-LP
DLV11-KA DLV11-KB DLV11-KC	DLVK1-H DLVK1-H DLVK1-H	None None None
DMV11-AA  DMV11-AB DMV11-AC DMV11-AP DMV11-BP DMV11-CP DMV11-FP	DMV11-M + CK-DMV11-A* DMV11-M + CK-DMV11-F* DMV11-N + CK-DMV11-B* DMV11-N + CK-DMV11-C* DMV11-M + CK-DMV11-A* DMV11-N + CK-DMV11-B* DMV11-N + CK-DMV11-C* DMV11-M + CK-DMV11-F*	DMV11-AP DMV11-FP DMV11-BP DMV11-CP DMV11-AP DMV11-BP DMV11-CP DMV11-FP
DPV11-DA DPV11-DB DPV11-DP	DPV11-M DPV11-M + CK-DPV11-A* DPV11-M + CK-DPV11-A*	None DPV11-AP DPV11-AP
DUV11-DA DUV11-DD DUV11-DE DUV11-DP	DUV11-M DUV11-M + CK-DUV11-A* DUV11-M + CK-DUV11-A* DUV11-M + CK-DUV11-A*	None DUV11-AP DUV11-AP DUV11-AP
DZV11-A DZV11-B DZV11-C DZV11-CP	DZV11-M DZV11-M + CK-DZV11-D* DZV11-M + CK-DZV11-D* DZV11-M + CK-DZV11-D*	None DZV11-DP DZV11-DP DZV11-DP
DRV11-D DRV11-B DRV11-JA	DRV11 + CK-DRV1B-K* DRV11-B + CK-DRV1B-K* DRV11-J + CK-DRV1J-K*	DRV11-LP DRV11-BP DRV11-JP
LPV11-AA LPV11-BA LPV11-EA LPV11-EB	LPV11-A + CK-LPV1A-K* LPV11-B + CK-LPV1A-K* LPV11-E + CK-LPV1A-K* LPV11-F + CK-LPV1A-K	LPV11-AP LPV11-BP LPV11-EP LPV11-FP
RLV22-AK	RLV22-AK + CK-RLV1A-K*	RLV22-AP
RXV21-EA RXV21-EC RXV21-ED	RXV21-EA + CK-RXV2E-K* RXV21-EC + CK-RXV2E-K* RXV21-ED + CK-RXV2E-K*	RXV21-EP RXV21-ES RXV21-ET
KDF11-BP	KDF11-BE/BA + CK-KDF1B-K*	N/A
IBV11-P	IBV11-A	N/A

\* Several cabinet kits are available. Use the following table to determine what letter replaces the asterisk.

Last Letter of Suffix	Cabinet Kit Where Used
A	Used with PDP-11/23S
B	Used with MICRO/PDP-11
C	Used with PDP-11/23-PLUS

**UNIBUS Option Conversion Table**

Old Option	Upgrade Option	System Option
DH11-AA DH11-AB DH11-AC DH11-AD DH11-AE	Obsolete Obsolete Obsolete DH11-M + CK-DH11-A* DH11-M + CK-DH11-D*	DH11-AP DH11-DP
DL11-E DL11-JA DL11-L DL11-LA DL11-LB DL11-W DL11-WA DL11-WB DL11-WC	DL11-M + CK-DL11-A* Obsolete Obsolete Obsolete Obsolete Obsolete DL11-N + CK-DL11-H* DL11-N + CK-DL11-D* Obsolete	DL11-AP      DL11-HP DL11-DP
DMP11-AA  DMP11-AB DMP11-AC DMP11-AE	DMP11-M + CK-DMP11-A* DMP11-M + CK-DMP11-F* DMP11-M + CK-DMP11-B* DMP11-M + CK-DMP11-C* DMP11-M + CK-DMP11-E*	DMP11-AP DMP11-FP DMP11-BP DMP11-CP DMP11-EP
DMR11-AA  DMR11-AB DMR11-AC DMR11-AE	DMR11-M + CK-DMR11-A* DMR11-M + CK-DMR11-F* DMR11-M + CK-DMR11-B* DMR11-M + CK-DMR11-C* DMR11-M + CK-DMR11-E*	DMR11-AP DMR11-FP DMR11-BP DMR11-CP DMR11-EP
DUP11-DA	DUP11-M + CK-DUP11-A*	DUP11-AP
DV11-AA DV11-BA DV11-BB DV11-BC	DV11-M DV11-N (X2) + CK-DV11-A* DV11-P (X2) + CK-DV11-A* DV11-N + DV11-P + CK-DV11-A*	DV11-AP DV11-1P DV11-2P DV11-3P
DZ11-A DZ11-AA DZ11-B** DZ11-BA DZ11-C DZ11-D** DZ11-E DZ11-EA DZ11-F	DZ11-M + CK-DZ11-D* DZ11-M + CK-DZ11-D* DZ11-M + CK-DZ11-DD DZ11-M + CK-DZ11-DE DZ11-N + CK-DZ11-H* DZ11-N + CK-DZ11-H* DZ11-M (X2) + CK-DZ11-D* (X2) Obsolete DZ11-N (X2) + CK-DZ11-H* (X2)	DZ11-DP DZ11-DP DZ11-DP DZ11-DP DZ11-HP DZ11-HP DZ11-DP (X2)  DZ11-HP (X2)
RX211-BA RX211-BC RX211-BD	RX211-BK RX211-BM RX211-BN	RX211-BK RX211-BM RX211-BN

\* Several cabinet kits are available. Use the following table to determine what letter replaces the asterisk.

\*\* If you have an unshielded cabinet and a DZ11-A(C), order a DZ11-B(D) to upgrade. If you have an old DZ11 with unused distribution panel capacity, continue to order old options (see above). Once the available capacity is filled, you should order new modules with the appropriate cabinet kits.

Last Letter of Suffix	Cabinet Kit Where Used
D	Any UNIBUS PDP-11 or VAX shielded cabinet
I	Any UNIBUS PDP-11 or VAX non-shielded cabinet

**Note:** (X2) means 2 units must be ordered to obtain 8 line interface equivalent to old option.





Figure 1: Schematic diagram of a multi-stage amplifier circuit.



Figure 2: Schematic diagram of a common-emitter amplifier stage.

# Index

---

## Application Software

ADE . . . . .	7-26
BCP . . . . .	7-25
DECgraph . . . . .	7-25
MENU-11 . . . . .	7-26
MicroPower/PASCAL . . . . .	7-17
PLXY-11 . . . . .	7-24
Professional Tool Kit . . . . .	7-26
PROVUE . . . . .	7-26
RGL . . . . .	7-25
RTEM . . . . .	7-27
VIGL . . . . .	7-25

## Cables

Communication Cables . . . . .	2-18
Realtime I/O Cables . . . . .	2-20

## Card Readers

CR11 Card Reader . . . . .	6-25
----------------------------	------

## Communication Options

Analog I/O	
AAV11 . . . . .	2-21
ADV11 . . . . .	2-21
AXV11 . . . . .	2-21
Digital I/O	
DRV11 . . . . .	2-20
DR11 . . . . .	2-20
DRS11 . . . . .	2-20
DSS11 . . . . .	2-20
IEEE Interfaces	
IEC . . . . .	2-22
IEU . . . . .	2-22
IEQ . . . . .	2-22
Q-bus Communication Options	
Asynchronous	
DLVE1 . . . . .	2-9
DLVJ1 . . . . .	2-9
DLVK1 . . . . .	2-9
DZV11 . . . . .	2-10
Synchronous	
DMV11 . . . . .	2-10
DPV11 . . . . .	2-11
DUV11 . . . . .	2-11
KMV11 . . . . .	2-11
UNIBUS Communication Options	
Asynchronous Multiplexers	
DZ11 . . . . .	2-13
DH11 . . . . .	2-13
Auxiliary Communications Microprocessors	
KMS11 . . . . .	2-16
Communications Controller	
DEUNA . . . . .	2-17
DELNI . . . . .	2-17
DEREP . . . . .	2-17
Modems	
DF02 . . . . .	2-17
DF03 . . . . .	2-17
Multipoint Parallel	
PCL11-B . . . . .	2-16

Multipoint Synchronous	
DMP11 . . . . .	2-15
Realtime Clocks	
KW11 . . . . .	2-22
KWV11 . . . . .	2-22
Single-line Asynchronous	
DL11 . . . . .	2-12
Single-line Synchronous	
DMR11 . . . . .	2-14
DUP11 . . . . .	2-13
Statistical Multiplexers	
DECmux . . . . .	2-16
DFM . . . . .	2-16

## Data Management Software

DATATRIEVE-11 . . . . .	7-23
FMS-11 . . . . .	7-23
QUILL . . . . .	7-23
SORT-11 . . . . .	7-23

## Disk Subsystems and Controllers

RA60 Removable Disk . . . . .	4-10
RA80 Fixed Disk . . . . .	4-7
RA81 Fixed Disk . . . . .	4-8
RD51 Disk Drive . . . . .	4-12
RL02 Cartridge Disk . . . . .	4-14
RLV12 . . . . .	4-6
RLV22 . . . . .	4-15
RQDX1 . . . . .	4-6
RUA80 Controller . . . . .	4-9
RUA81 Controller . . . . .	4-9
RX02 Floppy Disk . . . . .	4-16
RX50 Floppy Disk . . . . .	4-13
UDA50 . . . . .	4-4

## Educational Services . . . . . 9-7

## Environmental Products

Constant Voltage Conditioner . . . . .	2-26
Lightning Surge Suppressor . . . . .	2-27
Power Distribution System . . . . .	2-25

## Expansion Boxes

Component	
BA11-MA(MB) . . . . .	3-9
BA11-SA(SB) . . . . .	3-9
BA11-SE(SF) . . . . .	3-9
BA23-A . . . . .	3-9
Q-bus	
BA11-SE(SF) . . . . .	2-7
UNIBUS	
BA11-KU(KV) . . . . .	2-7

## Field Service . . . . . 9-3

<b>Languages</b>			
BASIC-PLUS-2 . . . . .	7-20	RSX-11M-PLUS . . . . .	7-16
BASIC-11/RT-11 . . . . .	7-20	RSX-11S . . . . .	7-16
COBOL-81 . . . . .	7-21	RSTS/E . . . . .	7-14
CORAL-66 . . . . .	7-21	RT-11 . . . . .	7-10
DIBOL-11 . . . . .	7-21	UNIX . . . . .	7-12
FORTRAN-77 . . . . .	7-20		
FORTRAN IV . . . . .	7-20	<b>Personal Computers</b>	
PASCAL . . . . .	7-21	<b>DECmate II</b>	
		Hardware Options . . . . .	5-7
		Software Options . . . . .	5-8
		Professional 325 and 350	
		Hardware Options . . . . .	5-10
		Software Options . . . . .	5-12
		Rainbow 100	
		Hardware Options . . . . .	5-5
<b>Q-bus Board Processors</b>			
KDF11 . . . . .	3-5	<b>PDP-11/23-PLUS</b>	
KDJ11 . . . . .	3-5	System Bases	
KXT11 . . . . .	3-6	11T23-BK(BL) . . . . .	1-12
		11V23-BE(BJ) . . . . .	1-12
		11/23-BC(BD) . . . . .	1-16
		11/23-BE(BF) . . . . .	1-16
		11/23-SC(SD) . . . . .	1-18
		11/23-SE(SF) . . . . .	1-18
		Systems	
		SX-RXMMMA . . . . .	1-12
<b>Memory Options</b>			
Component Memory Options		<b>PDP-11/24</b>	
MCV11 . . . . .	3-8	Building Blocks	
MRV11 . . . . .	3-8	SX-FX100 . . . . .	1-36
MSV11 . . . . .	3-8	SX-FX200 . . . . .	1-36
MXV11 . . . . .	3-8	Kernels	
Q-bus Memory Options		11X24-FA(FB) . . . . .	1-32
MCV11 . . . . .	2-6	Rackmount Computer Models	
MSV11 . . . . .	2-6	11/24-CC(CD) . . . . .	1-26
UNIBUS Memory Options		11/24-DC(DD) . . . . .	1-28
MS11 . . . . .	2-7	Systems	
		SX-FXMMB . . . . .	1-40
		SX-FXGMB . . . . .	1-42
<b>Microcomputer Development Tools . . . . .</b>			
	3-10	<b>PDP-11/44</b>	
		Building Blocks	
<b>MICRO/PDP-11</b>		SX-40100 . . . . .	1-38
System Bases		SX-40200 . . . . .	1-38
11A23-F . . . . .	1-10	Kernels	
11A23-R . . . . .	1-10	11X44-FA(FB) . . . . .	1-34
11C23-F . . . . .	1-10	Rackmount Computer Models	
11C23-R . . . . .	1-10	11/44-DA(DB) . . . . .	1-30
Systems		Systems	
SX-RA500 . . . . .	1-10	SX-40MMB . . . . .	1-44
		SX-40GMB . . . . .	1-46
		<b>Lineprinters</b>	
<b>Microprocessor Chips</b>		LN01 Printer . . . . .	6-21
DCJ11 . . . . .	3-4	LP25 Lineprinter . . . . .	6-22
DCK11 . . . . .	3-4	LP26 Lineprinter . . . . .	6-23
DCT11 . . . . .	3-4	LP27 Lineprinter . . . . .	6-24
		LSP25-CA Lineprinter . . . . .	6-22
<b>Networking Software</b>			
DECnet . . . . .	8-4		
Software Products . . . . .	8-5		
Internet . . . . .	8-7		
Software Products . . . . .	8-7		
Packetnet System Interfaces . . . . .	8-9		
Software Products . . . . .	8-10		
<b>Operating Systems</b>			
CTS-300 . . . . .	7-11		
DSM-11 . . . . .	7-13		
MicroPower/PASCAL . . . . .	7-17		
Micro/RSX . . . . .	7-17		
RSX-11M . . . . .	7-15		

# Index

---

LSP26-CA Lineprinter . . . . .	6-23	<b>Tape Subsystems</b>	
LXY12 Lineprinter/Plotter . . . . .	6-19	TE16 Magnetic Tape . . . . .	4-23
LXY22 Lineprinter/Plotter . . . . .	6-19	TSV05 Magnetic Tape . . . . .	4-21
		TU58 Cartridge Tape . . . . .	4-24
		TU77 Magnetic Tape . . . . .	4-22
		TU80 Magnetic Tape . . . . .	4-20
<b>Processor Options</b>		<b>Terminals</b>	
Component Q-bus Processor Options		Hardcopy Terminals	
FPF11 . . . . .	3-7	LA12 DECwriter Correspondent Printer . . . . .	6-17
KEF11-AA . . . . .	3-7	LA50 Personal Printer . . . . .	6-14
KTF11 . . . . .	3-7	LA100 Letterwriter/Letterprinter . . . . .	6-16
KXT11-A2 . . . . .	3-7	LA120 DECwriter III Printer . . . . .	6-18
Q-bus Processor Options		LQP02 Letter Quality Printer . . . . .	6-15
FPF11 . . . . .	2-7	Video Terminals	
KEF11-AA . . . . .	2-7	Accessories . . . . .	6-10
KEF11-BB . . . . .	2-7	RT100 . . . . .	6-7
UNIBUS Processor Options		RT102 . . . . .	6-7
FPF11 . . . . .	2-7	RT137 . . . . .	6-7
FP11-F . . . . .	2-7	VT100 . . . . .	6-5
KEF11-AA . . . . .	2-7	VT101 . . . . .	6-5
KEF11-BB . . . . .	2-7	VT102 . . . . .	6-5
KE44-A . . . . .	2-7	VT125 Graphics Terminal . . . . .	6-8
		VT131 . . . . .	6-5
<b>Software</b>		<b>Word Processing Software</b>	
Application Software . . . . .	7-22	DECword/DP . . . . .	7-23
Data Management Software . . . . .	7-23	DECtype . . . . .	7-23
Languages . . . . .	7-20		
Operating Systems . . . . .	7-6		
Transferring Software to the MICRO/PDP-11 . . . . .	7-17		
Processing Software . . . . .	7-24		
<b>Software Services</b> . . . . .	9-5		

# Chart Index

---

<b>Cable Chart</b> . . . . .	2-18	<b>Ordering Information Charts</b>	
		Applications Packages . . . . .	7-27
<b>Configuring Charts</b>		Communications Software . . . . .	8-11
Component Processor & Memory Options . . . . .	3-11	Operating Systems . . . . .	7-17
DECnet Communication Hardware . . . . .	8-5	Programming Languages . . . . .	7-22
Disk Site Preparation . . . . .	4-18		
Hardcopy Terminals . . . . .	6-26	<b>Selection Charts</b>	
Lineprinters . . . . .	6-26	Board-Level Microprocessor . . . . .	3-3
Q-bus Processor Options and Memories . . . . .	2-28	Chip-Level Microprocessor . . . . .	3-3
Q-bus Communication Options . . . . .	2-29	Disks . . . . .	4-3
Q-bus Disks . . . . .	4-17	Hardcopy Terminals . . . . .	6-13
Q-bus Realtime Options . . . . .	2-31	Lineprinters . . . . .	6-13
Magnetic Tapes . . . . .	4-25	Magnetic Tapes . . . . .	4-19
Magnetic Tapes Site Preparation . . . . .	4-25	MICRO/PDP-11 . . . . .	1-5
PDP-11/24 Processor Options and Memories . . . . .	2-28	Networking . . . . .	8-3
PDP-11/44 Processor Options and Memories . . . . .	2-28	PDP-11/23-PLUS . . . . .	1-5
Power Cords . . . . .	6-11	PDP-11/24 . . . . .	1-22
UNIBUS Communication Options . . . . .	2-30	PDP-11/44 . . . . .	1-22
UNIBUS Disks . . . . .	4-17	Software . . . . .	7-4
UNIBUS Realtime Options . . . . .	2-31	Systems . . . . .	1-3
Video Terminals . . . . .	6-11	Video Terminals . . . . .	6-3