

digital

# control handbook

digital equipment corporation



1971

**digital**

**CONTROL HANDBOOK**

produced by the Control Products Group  
Digital Equipment Corporation, Maynard, Massachusetts

Copyright © 1968, 1969, 1970 by  
Digital Equipment Corporation

Digital Equipment Corporation makes no representation that the interconnection of its modular circuits in the manner described herein will not infringe on existing or future patent rights. Nor do the descriptions contained herein imply the granting of licenses to make, use, or sell equipment constructed in accordance therewith.

FLIP CHIP® is a trademark of Digital Equipment Corporation

**INTRODUCTION TO SOLID STATE**

**K SERIES CONTROL LOGIC MODULES**

**A SERIES LOGIC MODULES**

**UNIVERSAL HARDWARE AND ACCESSORIES**

**K SERIES APPLICATIONS**

**CONTROL PRODUCTS**

**NUMERICAL CONTROL PRODUCTS**

**PDP-14 PROGRAMMABLE CONTROLLER**

**CONTROL SYSTEMS**

**TRAINING AND DESIGN AIDS**

**ABOUT DIGITAL EQUIPMENT CORPORATION**

### **ACKNOWLEDGEMENTS**

The production of a publication of this size and complexity can be achieved only through the efforts and cooperation of dozens of people. These include engineers, writers, artists, and production personnel. While it is impossible to cite all, a few individuals deserve special mention. Among these are: John Bloem of the Control Products Group engineering staff who prepared and assembled most of the technical material for this Handbook; Elliott Hendrickson and his staff for their art direction and production assistance; and Joseph Codispoti for his editorial assistance. The cover of this Control Handbook was conceived and executed for Digital by Chris Murphy of Boston.

**September, 1970**

## FOREWORD

The DIGITAL Control Handbook is presented by Digital Equipment Corporation as a practical guide to solid state control logic. It is written for those who specify, design, manufacture or use electronic or mechanical logic for control of equipment ranging from basic stand alone machines, to complex transfer and processing equipment, to sensitive laboratory instrumentation. This fourth edition contains information on the latest developments in Digital's products for control and documentation on current techniques of their application.

For readers investigating solid state control logic for the first time, this book is especially appropriate as it contains a meaningful orientation to solid state, showing its relationship to older forms of electromechanical control. Part of this orientation is comprised of a straightforward presentation on how to convert from relay to solid state logic. Several practical examples are given on how the conversion is executed.

Of particular interest to machine tool builders and users, is the introductory documentation contained in this handbook on the new PDP-8 based system for direct numerical control. This edition also contains data on our substantially expanded line of analog logic modules, designed for a variety of industrial and other applications which require analog data handling with digital techniques. A brief description of the Corporation and its other products is also presented.

Our staff of control products specialists in over 60 offices around the world and our home office applications engineering staff are ready to assist you in developing solid state controls for your needs. If you have such an application, contact us. If you don't think you have an application, look over the material presented in this Control Handbook. It might change your mind.

# TABLE OF CONTENTS

Thumb Index .....	III
Foreword .....	V
<b>INTRODUCTION TO SOLID STATE</b> .....	<b>1</b>
<b>K SERIES CONTROL LOGIC MODULES</b> .....	<b>6</b>
Logic Symbology .....	18
Logic Module Data Sheets:	
Gating Modules, K0XX and K1XX .....	28
Flip-Flops and Memories, K2XX .....	55
Timers, K3XX .....	77
Manual Control Modules, K4XX .....	91
Interface Module Data Sheets:	
Inputs, K5XX .....	103
Outputs, K6XX .....	124
K Series Hardware and Accessories:	
Accessories Containing Electronics, K7XX .....	150
Mounting Hardware, K9XX .....	173
<b>A SERIES ANALOG MODULES</b> .....	<b>182</b>
<b>UNIVERSAL HARDWARE and ACCESSORIES</b> .....	<b>232</b>
<b>K SERIES APPLICATIONS</b> .....	<b>260</b>
Construction Recommendations .....	262
Relay Logic to K Series Conversion .....	268
Sequencers, Introduction .....	286
Timer Sequencers .....	288
Counter Sequencers .....	289
Shifter Sequencers .....	291
Polyflop Sequencers .....	292
Using K303 Timers for Frequency Setpoint .....	293
Estimating K303 Time Jitter .....	294
Combining K with M Series Modules .....	295
Combining K with A Series Modules .....	297
Combining K with R Series Modules .....	299
Pulse Generator From NAND Gates .....	300
K531 Quadrature Decoder .....	301
Sensor Converters .....	303
DC Drivers .....	307
Using K210s for Long Odd-Modulus Counters .....	309



# TABLE OF CONTENTS (Con't)

## K SERIES APPLICATIONS (con't.)

Parallel Counters .....	310
Annunciators .....	311
Multiplexing Thumbwheel Registers with K581 .....	313
Fixed Memory Using K281 .....	315
Pulse Rate Multiplier .....	316
Pulse Rate Squarer .....	317
Digital Integrator .....	318
Serial Adder .....	320
Stepping Motors, Introduction .....	321
Basic Two Way Shift Register .....	324
SLO-SYN Bifilar Motor Drive .....	324
Responsyn Motor Drive .....	325
Fujitus Motor Drive .....	326
Electrohydraulic Servo Motor .....	328
Voltage to Frequency Converter Using A207 .....	329
Current to Frequency Converter Using K303 .....	330
Using K604, K614 with 240 V .....	331

## CONTROL PRODUCTS .....

334

Numerical Control Products .....	336
Quickpoint-8 NC Tape Preparation System .....	338
Direct Numerical Control .....	352
PDP-14 Programmable Controller .....	360
Control Systems .....	380
Training and Design Aids:	
K Series Logic Lab .....	382
Computer Lab .....	392

## ABOUT DIGITAL EQUIPMENT CORPORATION .....

394

Warranty Statement and Discount Schedule .....

400

Price List and Numerical Index .....

401

Index .....

405



# Introduction to Solid State

Control system complexity and demands on reliability are rising with ever-increasing automation. More and more, control system designers are looking to solid state electronics for new answers to the old problems of reliability, complexity, and economy. Some of the answers are provided by solid-state digital logic designed for the industrial environment, and solid state analog-digital conversion to link analog sensors and actuators to digital control.

## **Why Solid State?**

The time-honored way to do control logic is with the deceptively simple-looking relay. The metal-to-metal contact area sees physical and chemical actions of remarkable complexity. Even the mechanical-magnetic interactions are involved enough to cause problems now and then. Still, relays sometimes respond beautifully to simple maintenance. If the contacts stick, force them apart; if they are dirty, clean them.

Railway signaling relays, operating perhaps a hundred times a day, accumulate 25 years and a million operations without failure. And modern sealed-contact relays can do 10 billion operations under the right conditions without wearing out. So why abandon well-proven, reliable components? Don't, unless it is necessary! But it is becoming necessary in a growing number of applications.

## **Reliability**

As profit margins grow tighter, and maximum process efficiency becomes a necessity rather than an ideal, control system reliability assumes greater importance. Faulty operation and machine downtime can swiftly and disas-

trously cut into the profit picture. With a highly complex control system, check-out can easily become a very costly and time consuming operation. Many factors affect the reliability of a control system. A major consideration is the speed at which the logic control elements must operate. At 1KHz, near the maximum rate for dry reed delays, 100 million operations accumulate in about 30 hours. Longer-lived mercury-wetted contacts, operating 100 times per second, accumulate 10 billion operations in about four years. Even if a four year component life is enough, there are applications where 100 operations per second are not. Solid state logic, with nothing to wear out, stick, or corrode, can operate almost indefinitely at 100,000 operations per second.

Complexity is another factor. Demands for more automation, more efficiency, more safety, more accuracy all result in increased control system complexity. As a result, the sheer numbers of logical decisions demand component reliability far greater than that acceptable in a small system. Solid state logic provides the degree of reliability needed in a large system, at reasonable cost.

### **Size**

Even the tiniest-contact reed relay coil is enormous alongside a transistor, or a complete integrated circuit, and most small control systems are not built with reed relays: to get the advantage of ruggedness or standardization, usually all the relays used are built to 300 volt or even 600 volt specifications whether they drive external loads or just relay coils. But a single small printed circuit board can easily accommodate a half dozen or more relay equivalents in logic capability, in a small fraction of the space of one 300 volt relay.

### **Computer Tie-In**

There are several levels of computer involvement possible, extending from incorporation of a computer as a part of an individual control system to the use of a central computer to monitor the performance of many independent control systems. Regardless of the level at which the computer interacts, its presence demands an interface between solid-state circuitry and the controlled machine or process. If such an interface is forced into existence by the present or projected future use of a computer, why not put solid state control logic behind it and gain the benefits of solid state speed, compactness, and reliability throughout the entire system?

Also, solid-state logic can communicate with existing analog sensors and actuators through solid-state analog-to-digital (A/D) and digital-to-analog (D/A) converters.

All of these factors tend to make solid state control systems increasingly attractive, particularly as their costs come down.

### **Who Should Be Designing For Solid State Controls?**

Broadly speaking, the decision between conventional relay controls and the new solid state controls, like most engineering decisions, hinges on comparative overall costs. Where three or four or a half dozen relays can do the whole job, the cost of a solid-state interface will seldom be justified unless high speeds are required. Very large or computer-oriented systems leave little justification for the use of relays.

For intermediate systems, the comparison is more complicated. The tabulation below can serve as a framework for a systematic review of factors you should consider before you specify your next control system.

Considerations	Factors Suggesting Relays	Factors Suggesting Solid State
Reliability	Control system failure causes no panic. Temporary manual control acceptable. Simple system, easy to trouble shoot.	Downtime cuts quickly into process profitability. Quick check-out of entire system in case of trouble desirable, instead of on-the-spot checking. Lives and property might be endangered by failure.
Cost	Low cost relays acceptable. Maintenance costs need not be considered. Personnel training costs important. System failures will not cause significant secondary costs.	High quality relays used for comparison. Costs of failure high. Installation space costly. Cost of future modifications must be considered. Maintenance costs over life could be important.
Complexity	Small systems, perhaps a half dozen relays or fewer.	Complicated systems, which would require fifteen or more relays to implement.
Sophistication	Traditional performance still acceptable.	New levels of performance are needed, calling for increased control system complexity to remain competitive.
Familiarity	Controls must be serviced by electricians who can not be retrained.	Environments already include other solid-state components or they will soon be added. Also, multi-system installations where a few controls technicians will cover a lot of equipment.
Growth	No foreseeable use of computers. Little likelihood of important modifications.	Added performance or safety features may be wanted later without tearing the system down. Computer tie-in might become desirable or is planned already.
Size	Plenty of space available.	Relay equipment might require separate balconies, restrict maintenance of machinery, or block aisles. Features added later must fit original enclosure.
Speed	Control system delays of tens of milliseconds acceptable. Operating rate is low, relay wearout no problem.	Compatibility with pulse tachometers, photoelectric pickups, electronic instruments required. Closed-loop stability demands quick response. High repetition rate that would cause wearout of moving parts.

### **Why Digital?**

Relays, solenoids, switches, fuses, locks, counters, annunciators, panel lights and panic buttons all have one thing in common: they are digital. All these devices (when working properly) are up, down, on, off, in, out; but never in-between. Strictly speaking, of course, you cannot get from on to off without passing through in-between. But digital devices pass through in-between at maximum speed, and without waiting around for doubt to creep in.

Non-digital devices like panel meters, potentiometers, and slide rules work in the "in-between" area, producing outputs that are proportional to the input. The angular position of a panel meter pointer is the analog of the magnitude of the electrical input. A potentiometer's voltage output is the analog of mechanical shaft position. In a slide rule, position is the analog of magnitude.

In a slide rule, accuracy is limited by the thickness of the calibrating marks and the difficulty of estimating values between them. Each space is an area of uncertainty. The same kind of uncertainty exists in every proportional electrical system, in the form of noise. In all but the most expensive analog equipment, the amount of noise, like slide rule error, limits accuracy to two or three significant figures.

Noise taken in this broad sense affects every proportional device. Noise is a major reason for the dominance of digital computers over analog computers where complex calculations are required. Small amounts of noise contributed by each analog input or computing element add up to degrade the accuracy of the answer. In digital circuits, the noise can be disregarded as long as it is below an "off" or "on" threshold level.

Analog controllers and servo systems, chart recorders, panel meters, and small analog computers are often simpler and cheaper than their digital equivalents, and should be used wherever they can do the job. But since so many commonly used control devices (from relays to panic buttons) are digital anyway, all-digital control is convenient. For complex control situations, digital methods can deliver accuracy and perform types of control beyond the ability of an analog system at any cost. And using solid state digital control, analog and digital devices can work together through A/D and D/A conversion. Better still, noise-free direct digital sensors and actuators can be used in the design of new process equipment.

### **Noise Immune Control Modules**

Because of their high sensitivity and speed, solid state components can respond to noise that relays would safely ignore. To use solid state logic with freedom from noise problems in the neighborhood of arcing contacts, brushes, welders, etc. requires special design considerations.

Unlike analog devices, digital circuits have a noise "threshold" above which a noise or signal must rise to cause any change in the output of the circuit. It is this threshold that accounts for the superiority of digital circuits in processing information through complex manipulations without loss of accuracy.

In the design of solid state logic for industrial use, this basic threshold feature of digital circuits can be exploited. By adding external capacitance, the speed, and thus the sensitivity, of the circuit can be lowered.

### **Noise**

Suppose that on the basis of the above, you find you should be using solid-state digital logic. But will the system "drop bits," or otherwise go haywire in your environment? How well can noise trouble be anticipated, and what measures should be taken? How can you compare the noise immunity of competing manufacturers' circuits? These questions need some kind of answer before you can feel confidence in taking the step.

A logical starting point is the noise itself. What is its amplitude? Its frequency distribution? How does it vary with time? With temperature? How many picofarads of coupling capacitance between the noise sources and the logic wiring? How many nanohenries of shared inductance in the logic and noise ground return paths?

Right away you suspect these questions are going to be difficult to answer. You may be able to say that typical noise source voltages are "measured in kilovolts" and are "strongest in the Megahertz frequencies." But going beyond such hazy estimates will require detailed knowledge of the physical conditions that interact to produce electrical noise. You'll need to know the materials used in all metal-to-metal contacts, and the condition of the contact surfaces. You'll need the inductance and capacitance of the wires connecting them, the inductance and capacitance of the loads they drive, and the gases in the atmosphere surrounding the contacts. Even the exact routing of the wires will have to be examined.

Is solid-state out of the question after all, because analysing the noise environment is impractical? No, solid-state can still be used, provided you use circuits designed specifically for noisy environments, where the focus is on qualitative rather than quantitative factors.

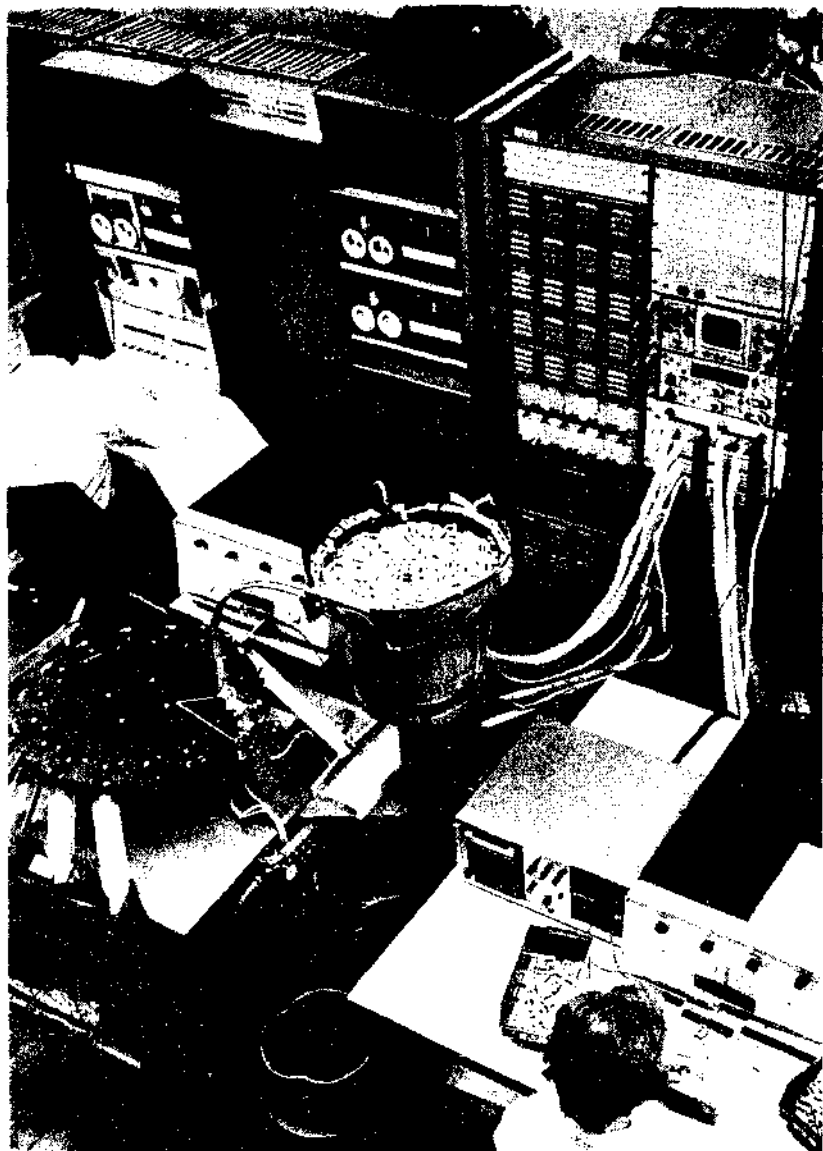

All incoming integrated circuits undergo computer controlled testing, with 40 dc and 16 ac tests performed in 1.1 seconds. This 100% inspection speeds production by minimizing the diagnosis of component failures in module test.





# **K Series Control Logic Modules**

## K SERIES CONTROL MODULES

Computer-oriented logic, by its very nature, is high speed (1 MHz and above), and provides noise immunity far below that required in a process control environment. The upper frequency range of the K Series modules is 100 KHz, with provision for reduction to 5 KHz for maximum noise immunity. These modules incorporate all silicon diodes, transistors, and integrated circuits, deliberately slowed through the use of discrete components.

Either English (non-inverting) logic or NAND/NOR logic is compatible with K Series. The hardware for this series is specifically designed for standard NEMA enclosures. FLIP CHIP mounting hardware can likewise be used for rack-mounting, inasmuch as K Series modules fit standard DEC sockets.

Proven FLIP CHIP connectors, used for years in applications from steel mills to lathe controls, provide modularity. Even the connection between terminal strips and electronics can be plugged for installing the logic after field wiring is complete, and removing it quickly for modifications or additions.

Checkout and trouble shooting is easy with K Series logic. Wherever possible, every system input and output has an indicator light at its screw terminal. A special test probe provides its own local illumination and built-in indication of transients, as well as steady states. Every point in the system is a test point, and consistent pin assignments reduce the need to consult prints.

Construction materials and methods are the same as for other high-production FLIP CHIP modules, including a computer-controlled operating test of each complete module. K Series modules further offer the size reduction, reliability, flexibility, and low cost of solid state logic, with an added bonus of easy interconnection. FLIP CHIP industrial modules are ideal for interfacing high speed M Series or computer-systems to machinery and processes. Sensing and output circuits can operate at 120 vac for full electromechanical capability. Inputs from contact devices see a moderate reactive load to assure normal contact life. Solid state ac switches are fully protected against false triggering. Voltages from the external environment are excluded from the wire-wrap connections within the logic.

### K SERIES SPECIFICATIONS

#### SUMMARY

Frequency range: DC to 100 KHz. Control points on the modules allow reduction to 5 KHz for maximum noise immunity for critical functions.

Signal levels: 0v and +5v, regardless of fanout used.

Fan-out: 15 ma available from all outputs; typical inputs 1-4 ma.

Waveforms: Trapezoidal. No fast transients to cause cross talk. External capacitive loading affects speed only; no risetime dependence.

Temperature range:  $-20^{\circ}\text{C}$  to  $+65^{\circ}\text{C}$ , using all-silicon diodes, transistors, and monolithic integrated circuits ( $0^{\circ}$  to  $150^{\circ}\text{F}$ ). (Limited to  $0^{\circ}\text{C}$  on the module types: K201, K202, K210, K211, K220, K230, K596).

Noise immunity: False "1":30 ma at 1.6v for 1.5  $\mu$ sec typical. False "0":3 ma at 3v for 1.5  $\mu$ sec typical. Time thresholds can be increased by a factor of 20 for critical points by wiring the slowdown control pins.

Simple power requirements: Single voltage supply, +5v  $\pm$ 10%. Dissipation typically 200 mw per counting or shifting flip-flop, 30 mw per control flip-flop, 10 mw per two-stage diode gate.

Control system voltage: 120 VAC, 50 or 60 hertz.

Mounting provisions: Standard NEMA industrial enclosures. May also be used in 19" electronics cabinets.

## GENERAL SPECIFICATIONS

### Construction Features

K-Series modules include the quality features of older lines of FLIP CHIP modules: flame-resistant epoxy-glass laminates, all-silicon semiconductors, gold plated fingers and solid gold connector contacts. Thorough testing of each module is by computer operated automatic tester for most modules, or by specialized equipment for those which are not amenable to automatic test. A test specification sheet or data sheet is packaged with each module, including a circuit schematic for that type. Monolithic or hybrid integrated circuits are included wherever they can improve the performance-cost ratio. Versatile mounting hardware imposes as few physical constraints as practicable. Outline drawings below show nominal module dimensions.

### STANDARD MODULE SIZES

SINGLE - WIDTH FLIP CHIP MODULE

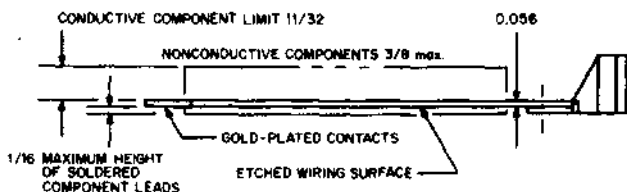

SINGLE - HEIGHT FLIP CHIP MODULE

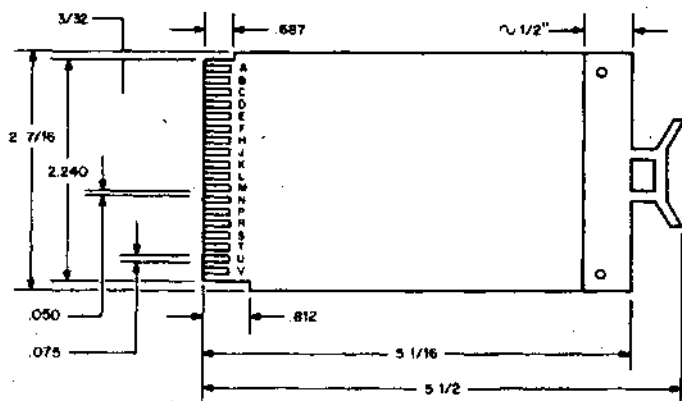

### DOUBLE-WIDTH FLIP CHIP MODULE

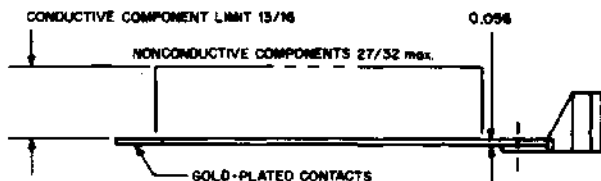

### DOUBLE-HEIGHT FLIP CHIP MODULE

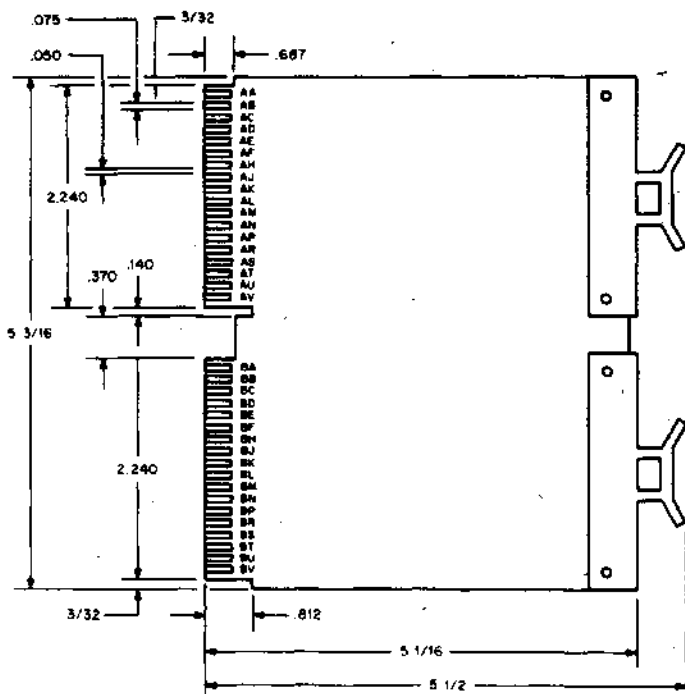

### Logic Signals

There are no ultra-fast transients at any K Series output. Logic signal "1" and "0" levels are essentially independent of fanout. Rise and fall transitions have controlled slopes which are not strongly influenced by normal changes in fanout, lead length, temperature, or repetition rate. The fastest K Series trapezoidal logic signal can be fully analyzed with a 500KC oscilloscope. Logic "1" or "true" is +5 volts and logic "0" or "false" is zero volts except where redefined by logic designer. Counters and shift registers advance at the "1" to "0" transition and are cleared by a "0" level. Any unused input may be left open.

### M Series Compatibility

M Series outputs can drive K Series logic gates and output converters directly, and any K Series input after passing through a K Series gate, provided they meet timing requirements. See Applications Notes.

## Loading

**Input Loading (Fanin)**—Each K Series input requires a certain amount of drive to operate, thus imposing a load on the output driving it. The amount of load imposed by an input is defined in terms of the amount of current required to pull that input to ground. Logic gate inputs consume 1 milliampere per input. Other loadings range from 1 to 4 milliamperes as indicated by the loading numbers enclosed in squares on each specification diagram.

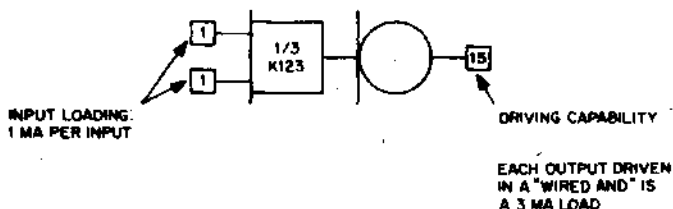

## FANIN AND FANOUT

**Output Loading (Fanout)**—Each K Series output is capable of sinking a certain maximum amount of current to ground in the low state. The standard K Series output can sink 15 milliamperes to ground and can therefore handle a maximum of 15 inputs, each requiring 1 milliampere of drive.

If K Series outputs are paralleled to obtain the wired AND logic function, each gate output is effectively driving the other and therefore, each output must be considered as a load on the others. To pull a typical output to ground requires 3 milliamperes of drive. When two or more K Series outputs are tied together, they produce a 3 milliampere load on each other. If, for example, the outputs of three K123 gates are connected, the combined fanout is reduced by 6 milliamperes, leaving 9 milliamperes of drive capability. A maximum limit of five outputs can be tied together reducing the fanout capability to three milliamperes.

## Operating Temperature

K Series modules are designed for operation in free-air ambient temperatures between  $-20^{\circ}\text{C}$  and  $+65^{\circ}\text{C}$  ( $0^{\circ}\text{F}$  to  $150^{\circ}\text{F}$ ) except the following types which are restricted to  $0^{\circ}\text{C}$  ( $32^{\circ}\text{F}$ ) minimum; K201, K202, K210, K211, K220, K230, K596.

## Speed

Many applications for K Series modules involve operation at rates lower than relay speeds. Even at speeds many times faster than relay capabilities, timing need not be considered unless the logic includes a "loop". A flip-flop constructed of logic gates is such a loop, in which the output at a given point feeds back to influence itself, thus demanding input durations longer than total loop delay. Proper operation of such loops should be verified by calculation using the specifications below. For a complex loop an experiment should be made if possible to look for flaws in the calculations.

When anticipated repetition rates will be of the same order of magnitude as rated logic frequency, more care is required in timing design. K Series circuits are intentionally slowed to the maximum extent practicable for 100 KHz operation, and the resulting propagation delays can limit complex logic systems to 50 KHz or 30 KHz repetition rates. Timing loops must be ex-

amined just as carefully in slow logic as in fast logic. If K Series speed appears marginal or insufficient for the job at hand, use M Series high speed logic modules.

### K SERIES TIMING

Timing Characteristics for K113, K123, K124, K202, K210, K211, K220, K230	Time ( $\mu$ sec)		
	Min.	Typ.	Max.
Logic Gate Propagation Delay, Time Delay for output to rise to 2.5v after input is sensed. Output D only, when connected to pin B	0.5 7.5	2.0 40	3.0 180
Logic Gate Propagation Delay, Time Delay for output to fall to 2.5v after input is sensed. Output D only, when connected to pin B	0.3 4.5	1.0 20	6.0 180
Count/Shift input Propagation Delay, Output Rise. As above, but pin B grounded to pin C	2.0 10	5.0 30	9.0 100
Count/Shift Input Propagation Delay, Output Fall As above, but pin B grounded to pin C	1.0 10	4.0 30	9.0 100
Rise time, all unslowed outputs, K113, K123, K124. (0v to +5v) Pin D output only, when connected to pin B	2.0 30	7.0 140	12.0 240
Falltime, all unslowed outputs, K113, K123, K124 (+5v to 0v) Pin D outputs only, when connected to pin B	.5 7.5	1.5 30	4.0 120
Minimum time between successive input transitions on any module which has one or more Count/Shift inputs. As above, but pin B grounded to pin C	4 10		

**Exceptions:**

Input transitions at pins J and K may follow other input transitions with delays down to zero; For characteristics not listed above, see timing information on individual data pages.

NOTE: Count/Shift inputs are included in types K202, K210, K211, K220, and K230

### Noise Immunity

Until recently, most industrial control designers were very skeptical of using logic modules in their control circuits. It was originally thought that these low logic level modules would be very susceptible to the large noise spikes which are so common in this industry. K Series modules, however, were specifically designed to work in noisy surroundings. Several noise rejection techniques were incorporated in their design, and operation in the field has proven that they can operate almost indefinitely under such conditions.

Two properties of electrical interference often overlooked in evaluating logic noise immunity are its source impedance and its frequency distribution. Unless the digital logic is spread over several feet or yards so that high potentials can be induced in the ground system, most noise will be injected via very small stray capacitances and hence will have a high source impedance. The voltages at the noise source itself are usually measured in thou-

sands of volts. Consequently, voltage thresholds alone cannot provide adequate noise rejection. The noise appears to come from a current source, so that logic circuit current thresholds are also an important measure of noise immunity.

Another means of controlling noise is by timing thresholds. Capacitive-coupled interference is strongest at high frequencies. Logic circuits which respond slowly can reject high frequency interference peaks that exceed the current and voltage thresholds.

Noise immunity in K Series modules is provided by a balanced combination of voltage, current, and timing thresholds. Techniques for increasing these noise rejection thresholds will be discussed in the remainder of this article.

Typical K Series noise thresholds are as follows:

1. To be falsely interpreted as a high (+5) level, a low (zero volts) K Series logic level must be raised 1.6 volts and held there for 1.5 microseconds. To do this would require 30 milliamperes to be supplied somehow from the noise source to the K Series output in question for this period of time.
2. To be falsely interpreted as low level, a high (+5) K Series logic level would have to be reduced 3.4 volts and held there for 1.5 microseconds, to do this would require 3 milliamperes to be supplied somehow from the noise source to the K Series output in question for this period of time.

**Voltage threshold:** The typical K Series circuit is a single voltage threshold device. This means that the circuit will turn on (low to high) at the same voltage threshold as it will turn off (high to low).

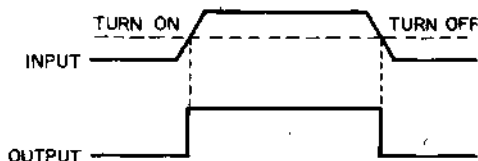

Some K Series modules, however, have a built-in feedback network which increases the voltage threshold necessary to switch from a low to a high output and decrease the voltage threshold needed to switch from a high to a low output. This results in a voltage gap between the turn on level and the turn off level, which is known as the hysteresis of the circuit.

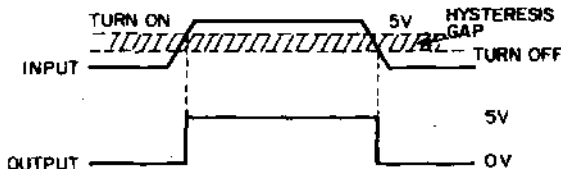

Those K Series modules which contain hysteresis have voltage gaps from .5 to 1 volt in width, resulting in a higher voltage threshold necessary to turn the circuit on. As an example: suppose a circuit turns on at 2.4 volts and turns off at 1.4 volts, then it would require a noise spike 2.4 volts high and 1.5 microseconds wide to trigger a false high level. To be falsely interpreted as a low level, a high level (+5) would now have to drop 3.6 volts for 1.5 microseconds.

**Current thresholds:** Current thresholds change with each variation in a circuit's voltage threshold. If a circuit has hysteresis, the noise source will need to supply the K Series output with even more current in order to cause a low level to be falsely interpreted as a high level, or a high level to be falsely interpreted as a low level. As an example: suppose a circuit has 1 volt hysteresis; if the turn on voltage threshold is 2.4 volts, then the noise source will need to supply 60 ma to the K Series output for 1.5 microseconds to obtain a falsely interpreted high output. The current threshold necessary to falsely interpret a low (0 v) level will increase to 3.2 ma.

**Timing thresholds:** All critical K Series outputs contain a slowdown, which prevents operation at frequencies above 100KHz. Many modules also provide pin connections for further slowdown to 5KHz. As discussed above most noise occurs at high frequencies, therefore the slower the logic circuits the more noise immunity. A typical example of slowdown in K Series:

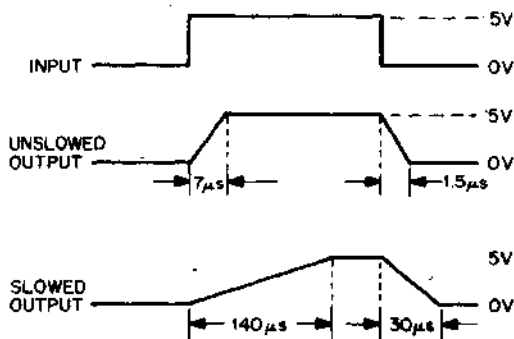

With 5KHz slowdown connected, a noise spike must now maintain the necessary voltage and current threshold levels for 30 microseconds instead of the typical 1.5 microseconds at 100KHz.

If a particular point in a logic system is exceptionally noisy, a capacitor can be hung to ground from that point. This method of noise reduction can be used because K Series logic does not care what rise time you feed it.

One trap often encountered by users of slowdown circuits occurs when control flip-flop (sealed AND) circuits are implemented. All control flip-flops should be slowed and any output of another gate wire ANDed to the output of a control flip-flop should also be slowed.



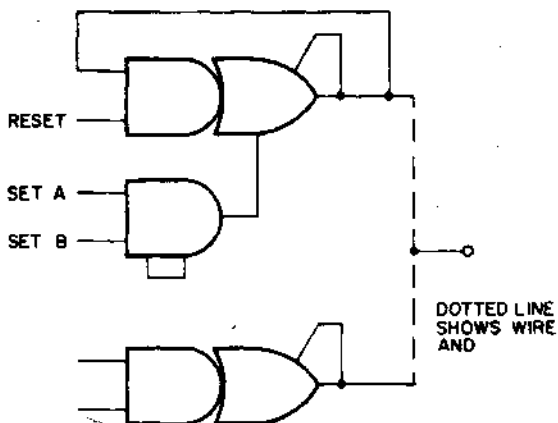

This precaution prevents noise problems in the system.

Up to this point, only those methods which can be used to minimize the influence of noise that has already entered a logic system have been discussed. Keeping noise out of a system, however, is far cheaper than electrically rejecting it. In this section, several methods of keeping noise out of a system will be discussed.

1. Segregate logic wiring from field wiring. Never design input converters and output drivers so field wiring goes through the same connectors used to carry logic signals. Arrange to use opposite ends of printed boards for logic and field wiring connections, and never allow the two kinds of wiring to be side-by-side or be bundled together.
2. Never mix logic ground with field ground. This does not mean that logic ground should float. Heavy currents should not pass through the logic ground system on their way back to a power supply. AC and DC isolation techniques used in K Series are as follows:

**AC Isolation**—AC Input Converters and AC Isolated Switches use transformers to isolate AC voltages from the logic. The inductance of the transformer windings prevents AC noise spikes from penetrating the logic circuit.

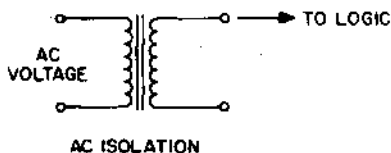

**DC Isolation**—DC Switch Filters and DC Drivers segregate high DC currents from the logic system ground by separating the supply and logic ground with a small resistor. With this resistor isolation, any

heavy currents in the DC ground level will be forced to flow through the ground return wire and not through the logic ground (path of least resistance.) The isolation resistor looks like a very high resistance compared to the ground return wire of the load supply.

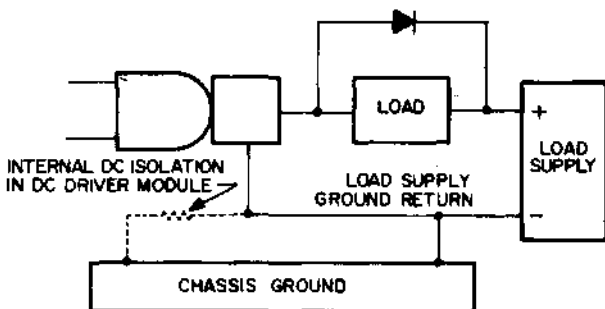

3. Use high-density packaging. Computer type modular construction minimizes lead lengths in the logic, minimizing the capacitive coupling between logic wiring and nearby field wiring. Dense packaging also cuts resistance and inductance in the logic grounding system, minimizing interference from any residual noise currents that may flow there.
4. Where logic and power circuits must be adjacent, use shielding. For example: a group of printed boards carrying field circuits can be shielded from general purpose logic modules simply by inserting un-etched copper clad boards in the sockets that separate the two groups. (Logic power must skip these sockets to avoid shorting the supply.) A single ground connection to the shield board is perfectly adequate, since the noise currents it carries will be limited by the small capacitance involved. (W993 electrostatic shields may be used.)
5. Filter the line voltage where it enters the logic power supply, or at supply output terminals. Supplies for panel lamps should also be filtered, if their wiring approaches logic wiring. Do not use logic power for any other function or carry supply output wires into the field for any reason.

#### Power Requirements

A simple 5 volt supply operates any K Series system. Tolerance at room temperature:  $\pm 10\%$ . K Series regulators K731 and K732 have a built-in temperature coefficient of approximately minus 1% for  $3^{\circ}\text{C}(5^{\circ}\text{F})$  to obtain full logic fanout over a wide temperature range and to minimize the temperature coefficient of K303 timers. Both regulators run from a nominal 12.6 volt center-tapped transformer secondary, with hash removed. See Construction Recommendations for information about alternate sources of logic power. Logic power is not used for contact sensing; 120 VAC is specified to provide full compatibility with silver contacts and noisy environments.



DEC engineer checks out part of a K Series control system.

## K SERIES LOGIC SYMBOLS

Symbols used in K Series diagrams are based on standard IC1-1965-15B for industrial controls issued by the National Electrical Manufacturers' Association ("NEMA"). For those not familiar with this standard, the basic symbols are defined below, along with equivalent symbols from U.S. Military Standard Mil STD-806B. K Series modules are designed to allow a logical "1" to be identified with the positive voltage level, and logical "0" with zero volts. The diagrams shown below follow this convention. Notice that except for timers, the two symbol standards are one-for-one interchangeable. For relay logic symbol conversion, see second Applications Note.

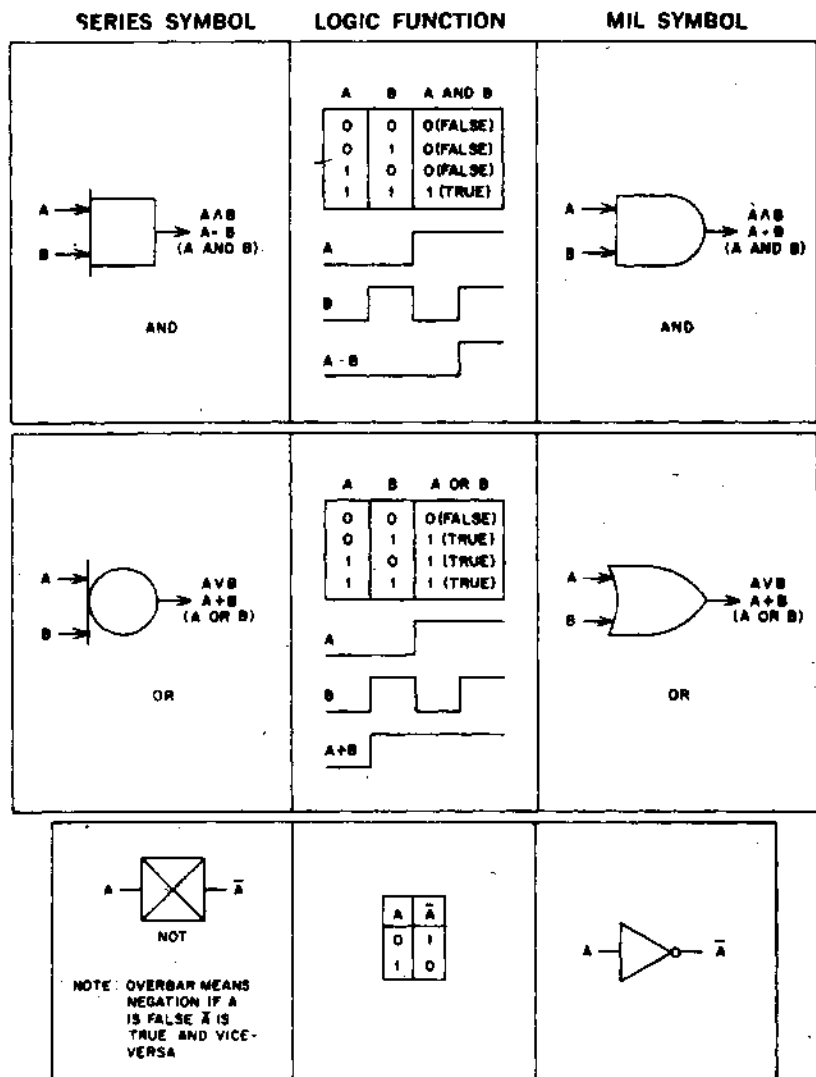

**K SERIES SYMBOL**

**LOGIC FUNCTION**

**MIL SYMBOL**

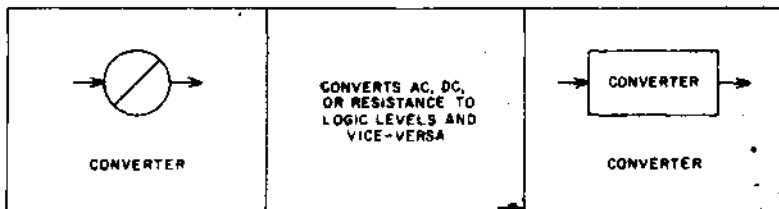
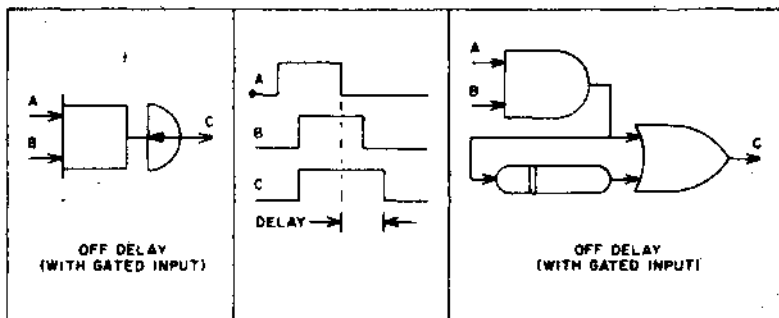
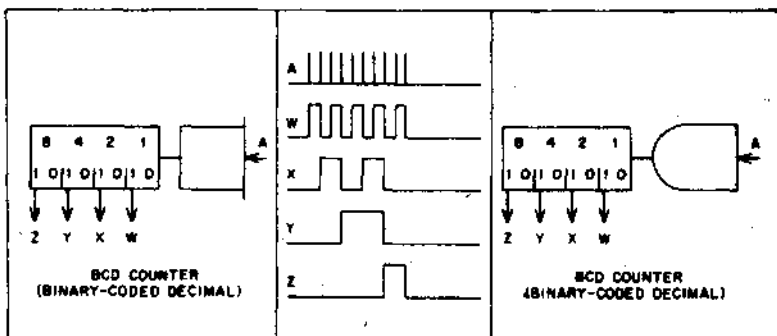
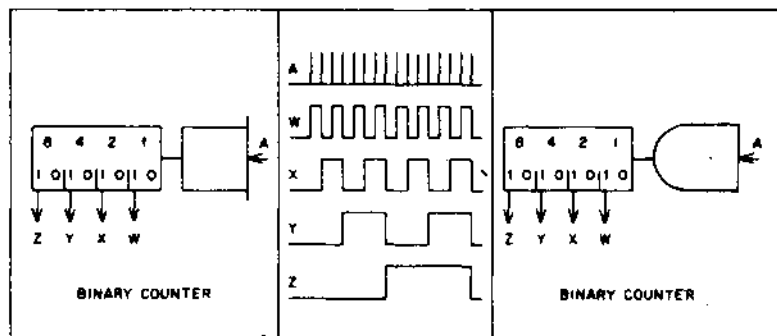

## K SERIES LOGIC

K Series is organized by groups according to the first number after the K.

### KNXX

These groups are as follows:

N = 0	Gate Expanders
N = 1	Gating
N = 2	Memory (flip-flops, counters, etc.)
N = 3	Timing
N = 4	External Controls
N = 5	Input Converters
N = 6	Output Converters
N = 7	Power
N = 9	Hardware

### WHAT IT DOES.

#### A. GATING—K100 GROUP

K Series gating modules combined with K Series gate expanders provide an extremely versatile method of implementing logic functions. Functions of high complexity can be implemented inexpensively using these gates and expanders.

The basic K Series gates are the K113 Inverting gate and the K123 Non-inverting gate.

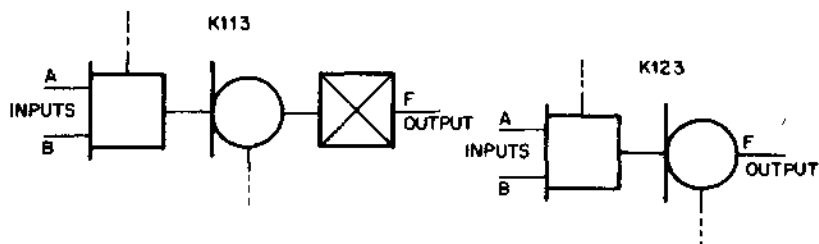

The K113 performs the NAND function  
 $F = \overline{A \cdot B}$

The K123 performs the AND function  
 $F = A \cdot B$

Notice that each basic K Series gate shows two inputs with dotted lines. These are the expansion inputs, which allow functions other than NAND or AND to be implemented.

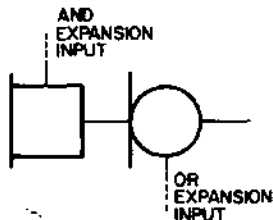

The "AND" expansion input is used with the K003 AND Expander, to provide the AND or NAND function for more than 2 inputs. For example, with one K003 AND Expander connected to a K123 Non-inverting gate we create a five input AND gate.

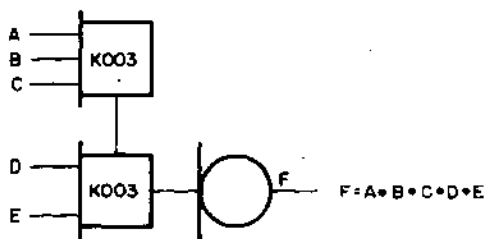

Up to 100 inputs may be connected to the AND Expansion input.

The "OR" expansion input is used with the K026 "AND/OR" expansion gate, or the K028 "AND/OR" expansion gate. Used with the K012, the K123 (or K113) becomes a 4 input "OR" (or Nor) gate.

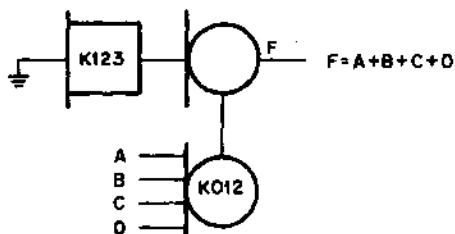

Up to 9 "OR" inputs can be connected to the OR expansion input.

When the OR expansion input is used, and the AND inputs are also used, the output of the AND gate is "ORed" with the OR expansion input.

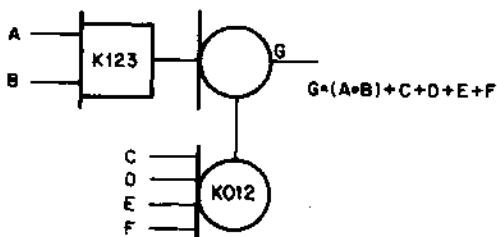

The K003 can be connected to the OR expansion input as follows:

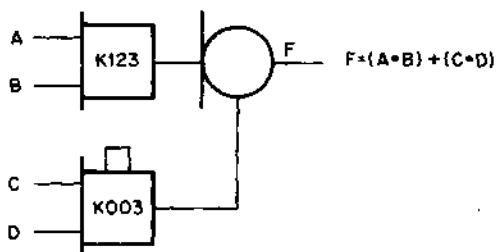

We can now begin to see the power of K Series gating. For instance, the function  $(A \cdot B \cdot C \cdot D \cdot E) + (F \cdot G) + H + I + J + K$  can be simply implemented with 1 K123, 2 K003, 1 K012 as follows:

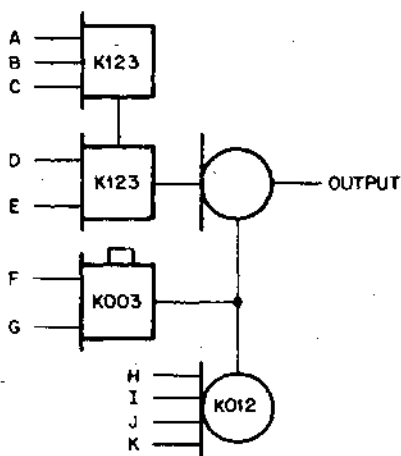

Producing functions with K Series logic takes some practice and ingenuity on the part of the logic designer, but once mastered will save money and time.

Some of the other functions available in the K100 series are

- Binary to Octal Decoder
- Equality and Digital Comparators
- Rate Multiplier

The Binary to Octal Decoder (K161) takes a 3 bit binary number and produces one out of eight lines high.

The Equality Comparator (K171) tells if two binary numbers are equal.

The Digital Comparator (K174) tells which of two binary numbers is greater.

The Rate Multiplier (K184) multiplexes inputs of different frequency.



## B. MEMORY—K200 GROUP

K Series contains a full line of flip-flops, counters, shift registers, and memory accessories.

In flip-flops, there are set-reset types (K201, K206) and Data (K202) flip-flops.

The K202 Data flip-flop looks as follows:

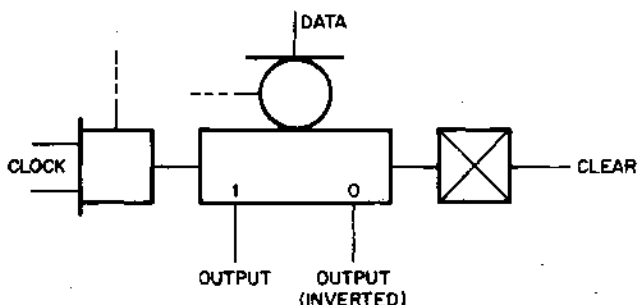

The D type flip-flop output goes to the state of the D input when the clock input falls from high to low. Notice the built in gates with expansion inputs on the clock and Data inputs. These allow simple input conditioning.

K Series has two counter modules. The K210 is a binary or BCD up counter (4 bits). Using expansion gates, it can be connected to count anywhere from 2 to 16.

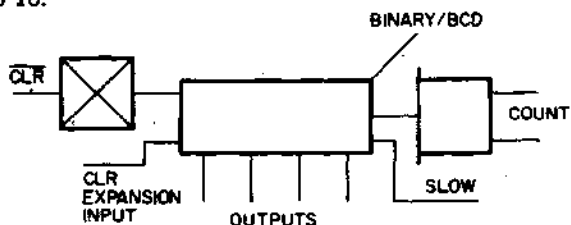

The K220 is a binary or BCD up/down counter which can be parallel loaded. With these two counters, virtually any counting function can be easily implemented.

The K230 4 bit shift register can be used in many shifting applications. Like the K220 counter, the K230 shift register can be parallel loaded.

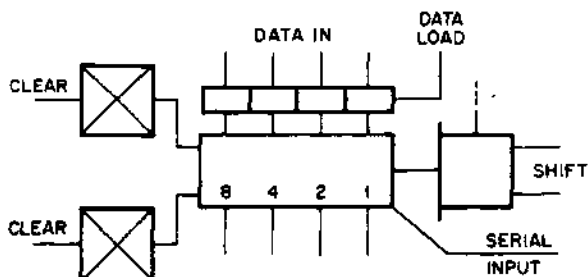

Several very useful memory accessories are the K271 and K273 retentive memories. These modules contain mercury wetted relays which can follow important data in a system, and retain that data should a power failure occur. The K273 for example contains 3 relays which can follow 3 bits of information. The retentive memories are an example of the wide versatility of K Series logic.

### C. TIMING—K300 GROUP

The K300 series contains modules used for clocks, delays, and one-shots. The K301, and K303 are delay modules with a range of 10 us to 30 seconds.

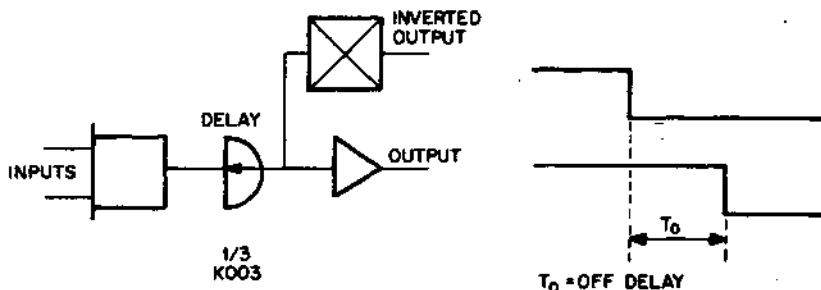

The K303 contains 3 delays, and when 2 of these delays are connected in the proper manner, they become a clock. The K323 is a one-shot, which converts an input transition (Hi to Lo) to an output pulse from 10 us to 30 seconds. The K333 provides three pulser circuits which produce variable output pulse widths.

The K300 series also contains a full complement of timing component boards, which bolt directly on the timing modules. These timing component boards contain convenient controls for setting to exact time required.

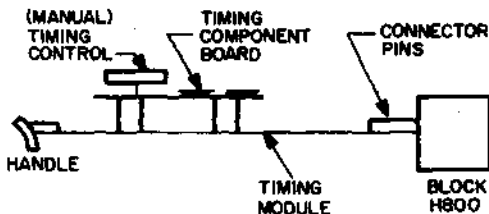

### D. EXTERNAL CONTROLS—K400 GROUP

The K400 series contains modules for controlling K Series systems from switches, thumbwheels, Nixies and indicator lights. They are physically designed to be mounted using a K950 control panel (optional) to provide a neat external control panel.

The modules in the K400 series are

- K410 Indicator Lights
- 5 Indicator Lights

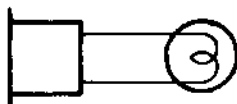

- K415 Nixie Display

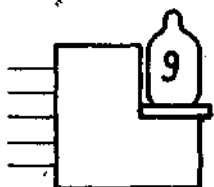

- K420 Switches
- 3 switches with built in switch filters

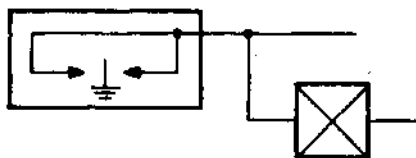

- K422 Thumbwheel Encoder
- 2 Thumbwheels (0-9) with circuitry to produce BCD outputs
- K424 Thumbwheel Decoder
- 2 Thumbwheels with circuitry to detect any BCD digit.
- K432 Timer Control
- Various timing components to be used with K300 series modules.

#### E. INPUT CONVERTERS—K500 GROUP

K500 series modules are used to convert various input signals to K Series logic levels.

Some of these are as follows:

### K501 Schmitt trigger

This is used to change a sloppy wave shape to a good wave shape.

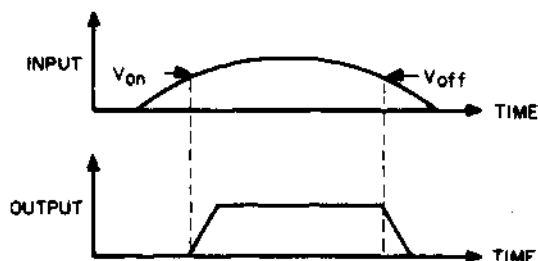

### K522 and K524 Sensor Converters

The K522 and K524 are basically operational amplifiers (high gain) used to convert resistance changes to logic levels. They can be used with variable resistance devices such as photo-conductive cells.

### K578 120 VAC Input Converter

This module is used to convert 120 VAC Inputs to logic levels.

The inputs to the converters are thru transformers which provide sufficient reactive load to keep contacts clean.

### K580 and K581 Dry Contact Filters

These filters are used with wiping type switches, and provide a voltage divider to change a high DC voltage to K Series levels.

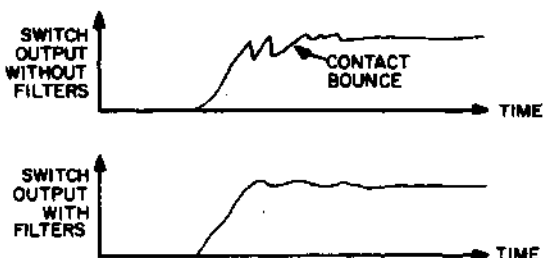

## F. OUTPUT CONVERTERS—K600 GROUP

The K600 series modules are used to convert logic levels to various voltages used external to the logic system. Some of these are as follows:

### K604 Isolated AC Switch

These are used to turn on and off AC devices such as solenoids, AC valves, small motors, motor starters, from logic levels. The K604 has 4 switches, each of which can handle 200 volt-amperes. Other Isolated AC switches (K614, K615) can handle up to 500 volt-amperes.

### K644 DC Driver

The K644 is used as a switch to drive stepping motors, DC solenoids, and similar devices rated up to 2.5 amperes at 48 volts. Other DC drivers are available for up to 4 amps or 250 volts. (K650, K652, K656, and K658).

#### **K671 Decimal Decoder and Nixie Display**

The K671 contains a side viewing Burroughs type nixie glow tube, and a decimal decoder. The glow tube is mounted at the end of a 12 inch flexprint cable for easy mounting. One type K771 power supply is needed for each 6 nixie displays.

#### **G. POWER—K700 GROUP**

Power is supplied to a K Series system by K Series power supply modules.

- K730 Rectifier for 10vdc and approx. 16vdc and sensing logic for 5vdc
- K731 Rectifier + Regulator for 5vdc
- K732 Slave Regulator
- K741, K743 Power transformer

A K Series power supply is made up of a K731 and some number of K732, and K741 or K743's depending on the current requirement of the system. For example, 1 to 3 amp load requires 1 K731, 1 K732, 2 K741 or 1 K743.

#### **H. MOUNTING HARDWARE**

The hardware available for K Series is very convenient.

The basic system is built from H800 sockets (8 slots per socket) mounted on a K941 mounting bar, mounted on a K940 bracket, mounted on the equipment mounting panel. Also 19" rack assemblies are available with power supply (16 sockets) or without power supply (64 sockets). Also module drawers are available.

A complete line of tools is available for wire wrapping the system, along with jumpers and bus strips.

# GATE EXPANDERS

K003, K012, K026, K028

# K SERIES

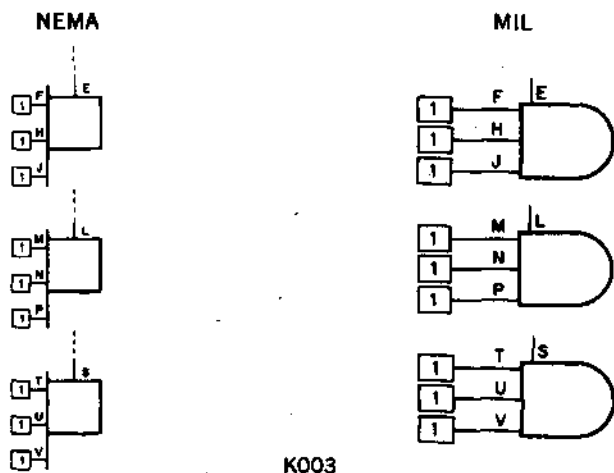

**K003 AND expander:** May be connected to the AND expansion node of any K Series module.

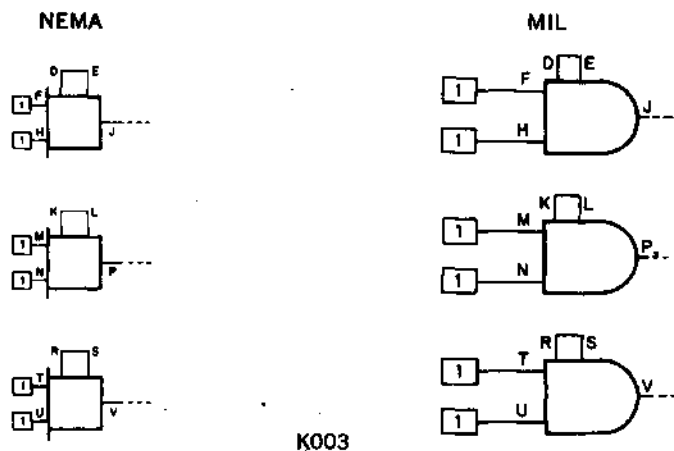

**K003 AND/OR expander:** May be connected to the OR expansion node of any K Series module.

K003—\$5
K012—\$8
K026—\$8
K028—\$8

NEMA

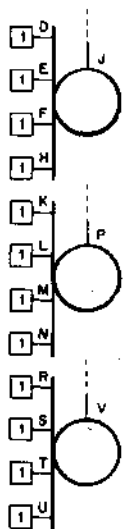

MIL

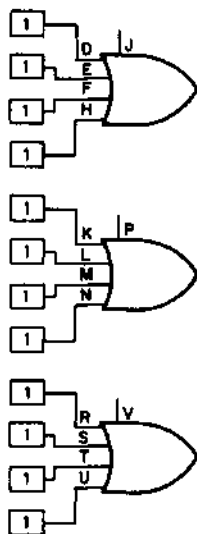

K012

K012 OR expander: May be connected to the OR expansion node of any K Series module.

NEMA

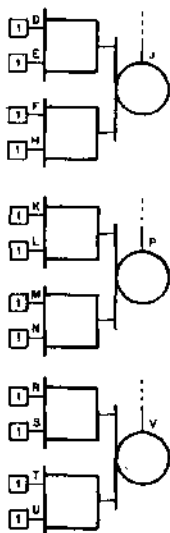

MIL

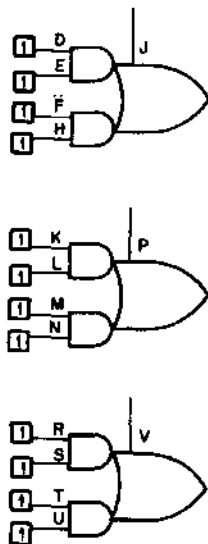

K026

K026 AND/OR expander: May be connected to the OR expansion node of any K Series module.

NEMA

MIL

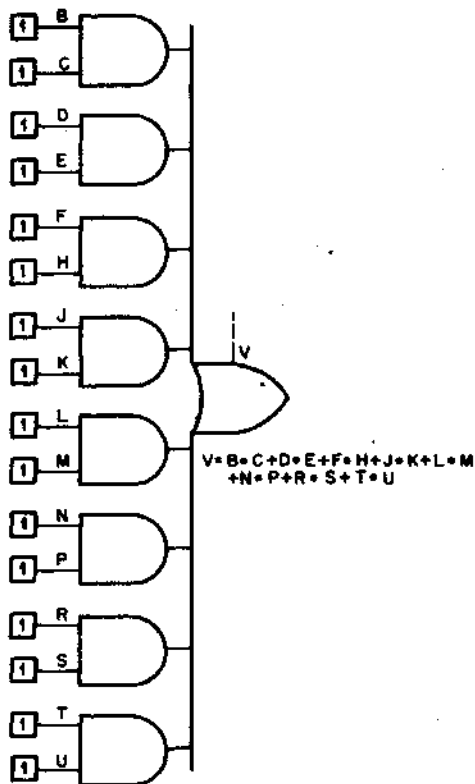
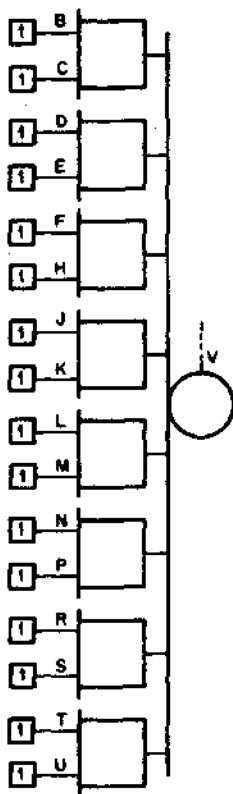

K028

**K028 AND/OR expander:** May be connected to the OR expansion node of any K Series Gate.

These inexpensive gate expanders offer great logic flexibility and versatility without a proliferation of module types. Logic functions performed by expanders are illustrated in combination with the K113 and K123 gates in several pages that follow the data sheet for the gates themselves.

It must be clearly understood that the gate expanders above are merely expansions for other K Series gates and can never be used as separate AND or OR functions.

Each K003 expander module has a .01 uf capacitor available at pin B which may be used to implement logic delays as shown in the Application notes or to further reduce the speed of a K Series output.

**Caution:** Pin C on K028 expanders should not be bussed to ground unless function B-C is not used.



**CABLE CONNECTOR**  
**K080**

**K**  
**SERIES**

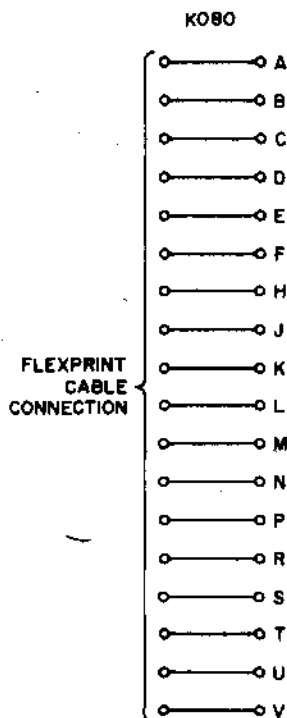

The K080 cable connector consists of a single height, single thickness board on which can be mounted a 19 conductor flexprint cable. Each module comes with a cable clamp for customer convenience.

**K080—\$3**

# LOGIC GATES

K112, K113, K122, K123, K124

# K SERIES

NEMA

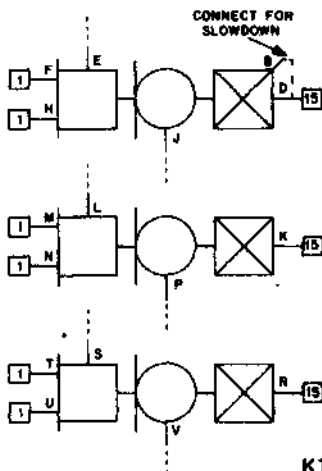

MIL

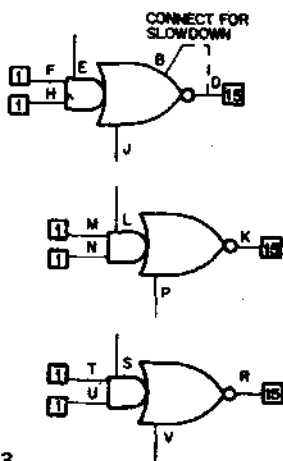

K112 and K113  
INVERTING GATE

NEMA

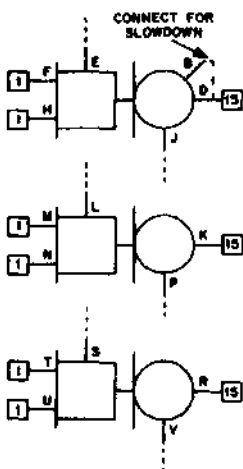

MIL

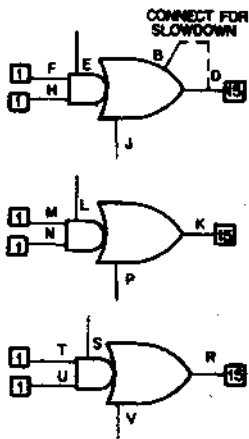

K122 and K123  
NON-INVERTING GATE

K112	—\$12
K113	—\$11
K122	—\$13
K123	—\$12
K124	—\$14

NEMA

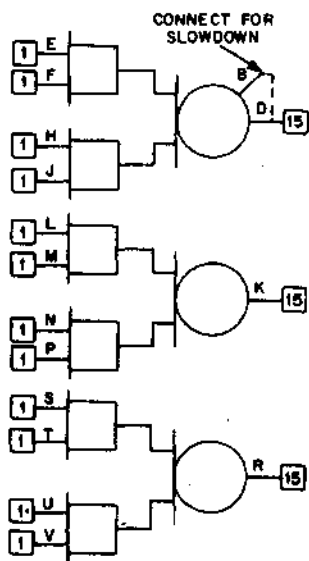

MIL

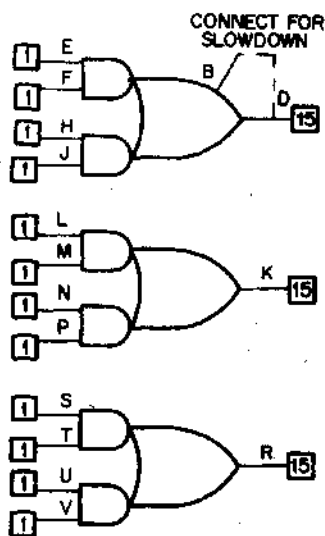

### K124 AND/OR GATE

Together with the K003, K012, K026 or K028 expanders, these gates perform any desired logic function, including AND, OR, AND/OR, NAND, NOR, exclusive OR, and wired AND.

Logic gate type K123 is an AND/OR non-inverting gate subject to expansion at either the AND or the OR node. Logic symbols and equivalent schematics are compared in the following illustrations. Typical pin connections are shown.

The AND input can be expanded up to 100 AND inputs total using pins E, L, and S. Up to 9 OR expansion inputs can be connected to the OR expansion pin (J, P, V). More OR expansion inputs can be added if faster fall times are acceptable. Both AND and OR functions can be expanded at the same time. Examples of gate expansion are shown in following pages.

Expansion of the K113 inverting gate is identical. The equivalent circuit is the same except for inversion in the output amplifier.

The K124 provides a convenient way to implement non-inverting gate control flip-flops, exclusive ORs, and two term OR logic equations without the need for expanders. The module is electrically the same as a K123 gate with a K003 expander.

Of the three circuits on each module only one has a slowdown capacitor that can be connected to the output to increase noise rejection when the gates are interconnected to make control flip-flops. Use of this capacitor increases rise and fall time by approximately a factor of 20. The maximum speed of each unslowed gate is 100KHz and the maximum speed of a slowed gate is 5KHz.

The K112 and K122 modules are logically identical to the K113 and K123 respectively. They feature maximum speeds of 1KHz with a single connection on one circuit for slowdown to 50 Hz. This added slowdown feature gives these two modules an even greater level of noise immunity.

## SLOWDOWN AND DELAY

To show the effects of slowdown and delay-connections on K-Series outputs, suppose a pulse entered a K123 Non-Inverting Gate; the following outputs would be realized.

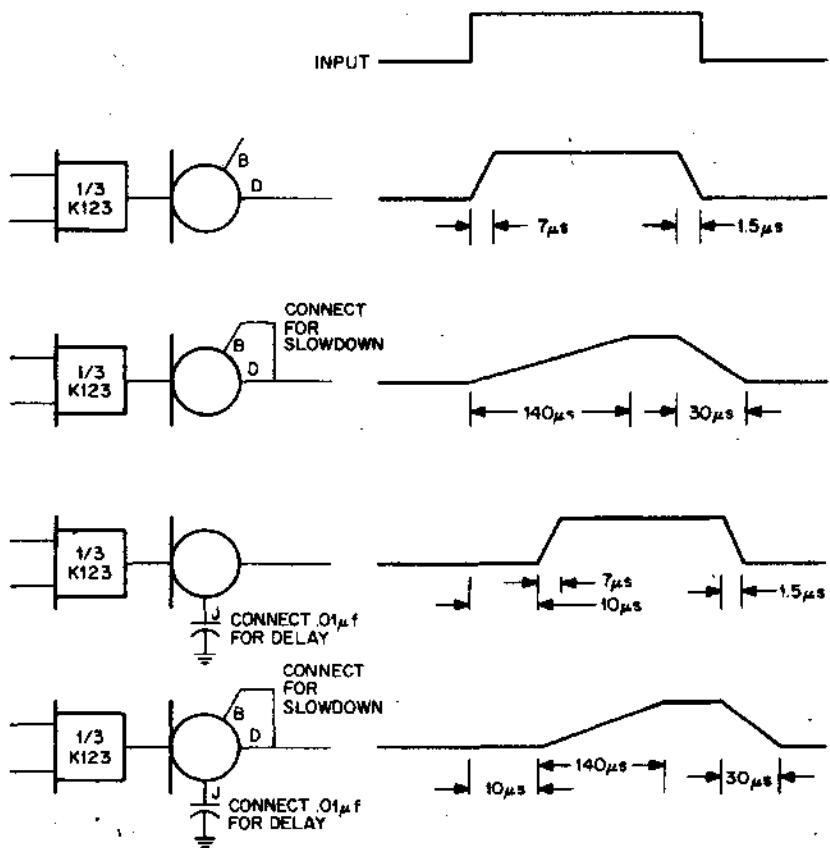

Time shown above are typical values and should not be considered exact. Delay times are increased by  $10\mu\text{s}$  for each  $.01\mu\text{f}$  capacitor connected to pin J.

### LOGIC SYMBOL

### SIMPLIFIED SCHEMATIC

NEMA

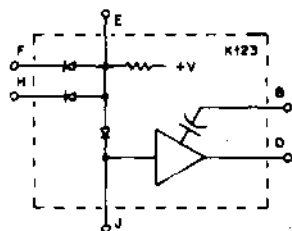
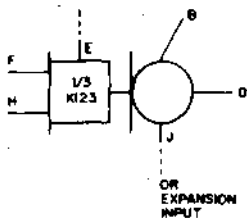

MIL

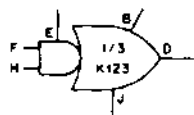

### BASIC GATE

NEMA

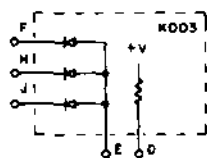
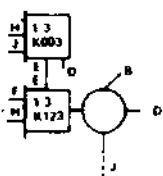

MIL

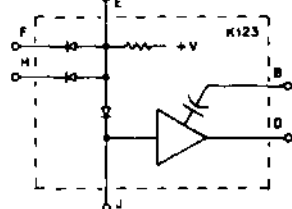
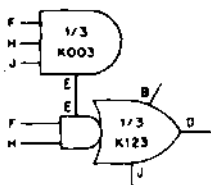

### K003 AND EXPANSION

NEMA

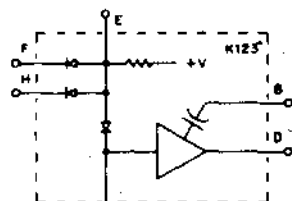
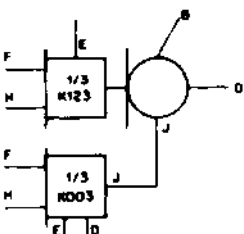

MIL

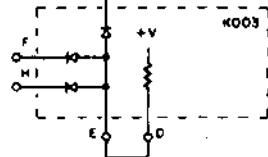
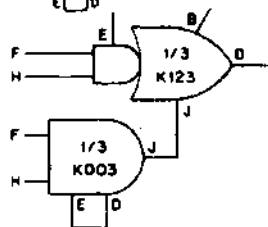

### K003 OR EXPANSION

### LOGIC SYMBOL

### SIMPLIFIED SCHEMATIC

NEMA

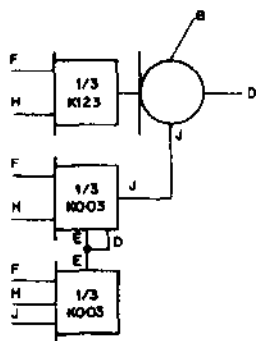

MIL

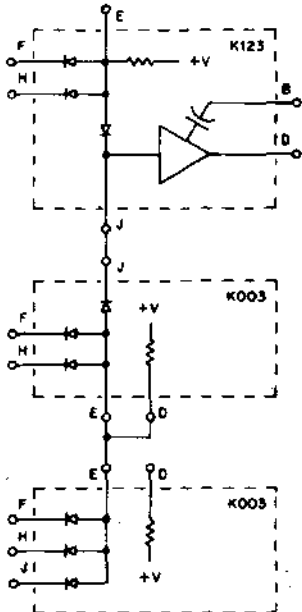
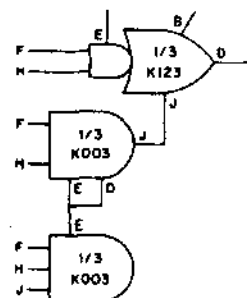

K003 AND/OR EXPANSION  
(K026 MAY ALSO BE USED)

NEMA

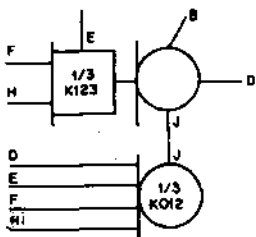

MIL

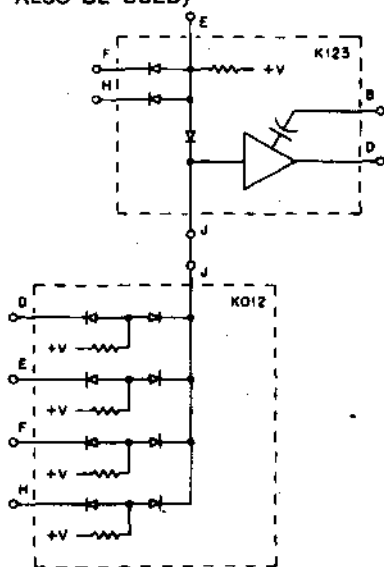
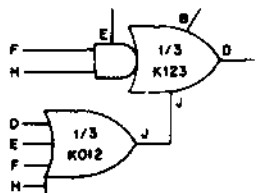

K012 OR EXPANSION

The basic types of logic functions obtainable by expansion are shown below for the K123 non-inverting gate. Logic functions for the expanded K113 inverting gate are identical except for inversion of the output. Letters refer to logic signal names rather than module pin numbers.

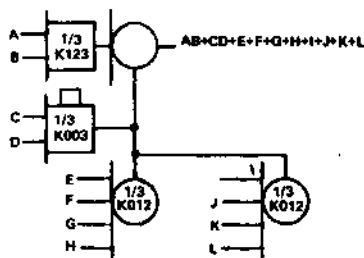
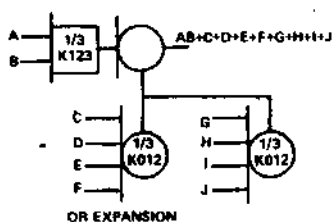
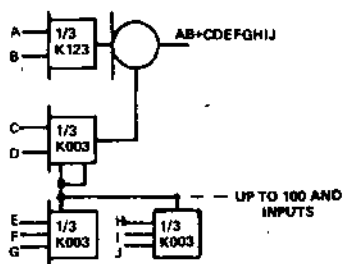
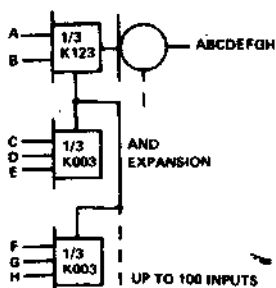
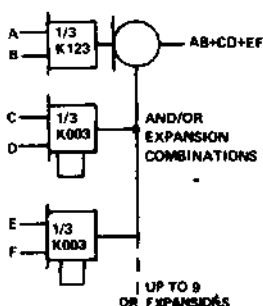
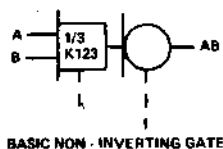

### LOGIC FUNCTIONS WITH GATE EXPANSION



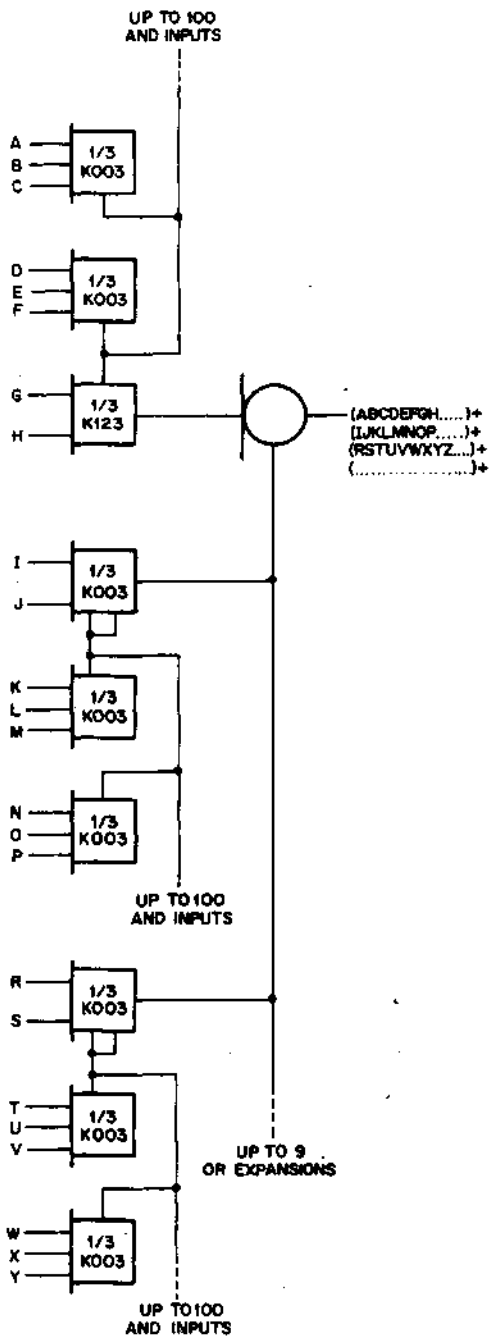

## NAND, NOR, EXCLUSIVE OR

The K113 inverting gate performs the NAND function directly, and performs the NOR function when combined with a K003 expander.

With proper input connections, the K124 non-inverting gate performs the exclusive OR function.

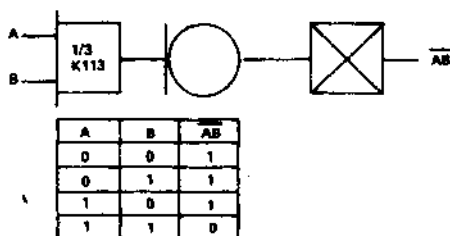

NAND FUNCTION OF BASIC INVERTING GATE

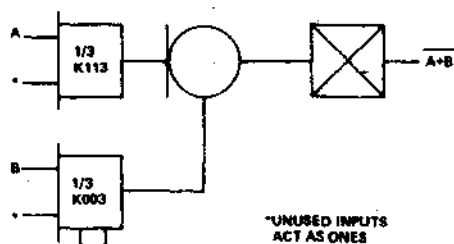

NOR FUNCTION OF BASIC INVERTING GATE WITH EXPANDER

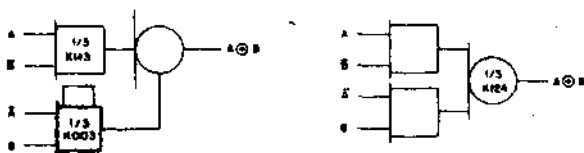

A	B	$A \oplus B$
0	0	0
0	1	1
1	0	1
1	1	0

EXCLUSIVE OR CONNECTION OF BASIC NON-INVERTING GATE WITH EXPANDER

## WIRED AND

Wired AND functions can be obtained by connecting K123 outputs to other K124, K123 or K113 outputs as shown below. Any K Series output with a fanout of 15 may be wired ANDed.

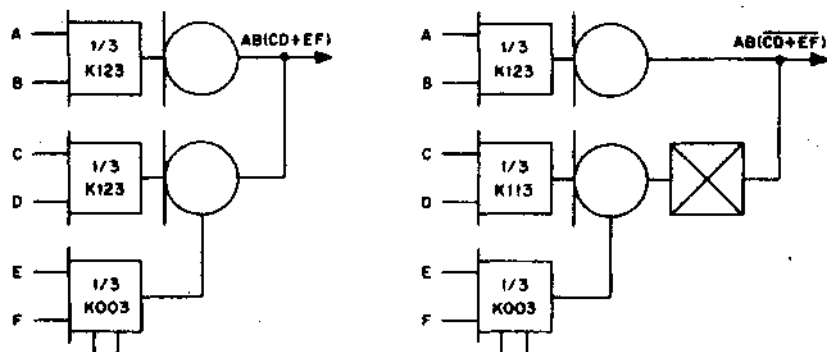

## WIRED AND EXAMPLES

### SUMMARY OF GATE-EXPANDER LOGIC COMBINATIONS

FOR ZERO VOLTS DEFINED AS LOGIC ZERO standard definition			
Logic Function	No. of Inputs	Expanders	Gates
AND	2	none	1/3 K123
	3-5	1/3 K003	1/3 K123
	6-8	2/3 K003	1/3 K123
OR	2	1/3 K003 or 1/3 K012	1/3 K123
	3-5	none	1/3 K124
	6-9	1/3 K012 2/3 K012	1/3 K123 1/3 K123
NAND	2	none	1/3 K113
	3-5	1/3 K003	1/3 K113
	6-8	2/3 K003	1/3 K113
NOR	2	1/3 K003 or 1/3 K012	1/3 K113
	3-5	1/3 K012	1/3 K113
	6-9	2/3 K012	1/3 K113

FOR ZERO VOLTS DEFINED AS LOGIC ONE (inverted definition)			
Logic Function	No. of Inputs	Expanders	Gates
AND	2	1/3 K003	1/3 K123
	3-5	or	
	6-9	1/3 K012 none 1/3 K012 2/3 K012	1/3 K124 1/3 K123 1/3 K123
OR	2	none	1/3 K123
	3-5	1/3 K003	1/3 K123
	6-8	2/3 K003	1/3 K123
NAND	2	1/3 K003	1/3 K113
	3-5	or	
	6-9	1/3 K012 1/3 K012 2/3 K012	1/3 K113 1/3 K113 1/3 K113
NOR	2	none	1/3 K113
	3-5	1/3 K003	1/3 K113
	6-8	2/3 K003	1/3 K113

## CONTROL FLIP-FLOP FROM GATES

Control flip-flops can be formed by the interconnection of gates as shown below. For applications in systems where speeds are below 5KHz or where noisy environments exist, these flip-flops should always be slowed. When these control flip-flops are slowed, any gate output wire ANDED to them should also be slowed.

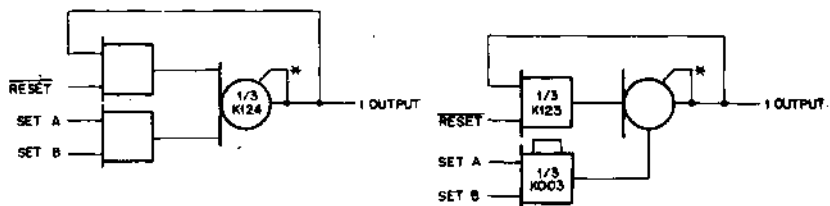

## NON-INVERTING GATE CONTROL FLIP-FLOP

The output of the flip-flop above is set to a ONE when the two SET inputs are both ONES. A ZERO at the RESET input returns the output to ZERO, provided at least one of the SET inputs is also ZERO.

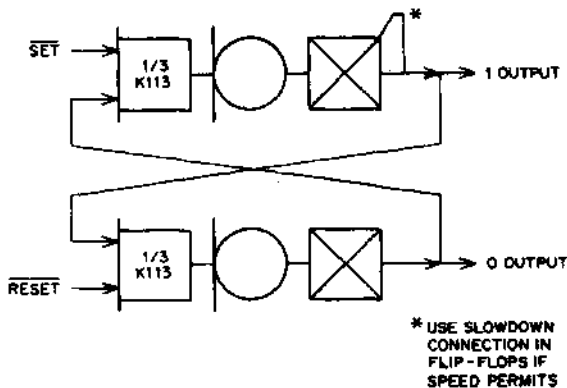

## INVERTING GATE CONTROL FLIP-FLOP

The flip-flop above, made from two inverting gates, provides complementary 1 and 0 outputs. A truth table is shown below.

TRUTH TABLE

SET	RESET	1 OUTPUT	0 OUTPUT
0	0	1	1
0	1	1	0
1	0	0	1
1	1	NO CHANGE	

# INVERTERS

K134

**K**  
SERIES

NEMA

MIL

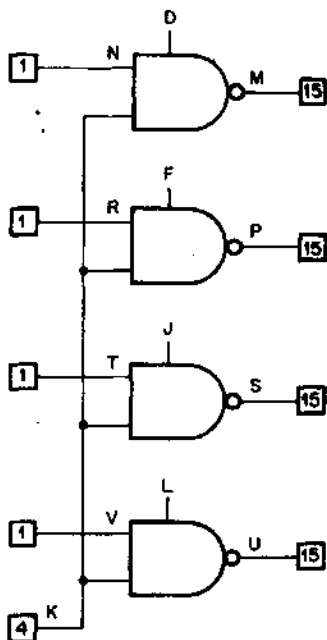
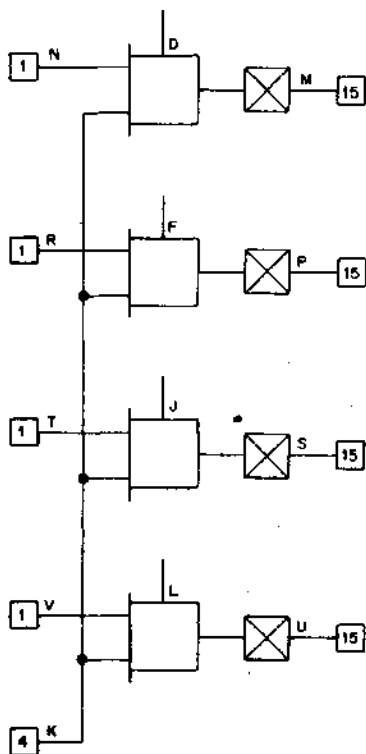

## K134 INVERTERS

Four flip-flop functional modules such as K210, K220, K230 can conveniently be augmented by a K134 to get "0" as well as "1" outputs. The K134 is also provided with expansion and inhibit inputs for use as the readout element of ready-only memories using K281 diode memories (See Applications Notes). A common input at pin K can force all four outputs high, a helpful feature for building large K281 memories or very large K161 decoders.

K134 inverters may also be AND expanded by K003 gate expanders, providing an efficient way to obtain 4-input NAND or inverted NOR gates.

K134—\$13.

# INVERTERS

K135

K  
SERIES

NEMA

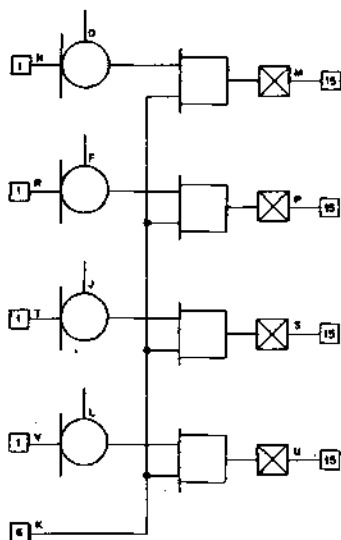

MIL

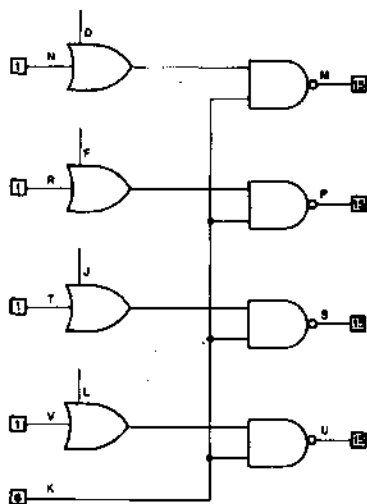

## K135 INVERTERS

The K135 module was designed primarily for use in applications that require inverters with "OR" expandability. A common input at pin K can force all four outputs high regardless of the "OR" gate inputs. This feature is useful if a K161 decoder is used for multiplexing K135 modules, since all outputs for the same bit can be wire "AND"ed together.

The loading on pin K is initially 6 with no "OR" expansions and increases by "1" unit load for each "OR" input that is added to the module. For example, if a K012 expander was added to each of the four inverters, the total pin K load would be 22 unit loads.

K003 expanders can be used for AND/OR expandability. The number of AND inputs on a given OR input does not affect the loading of pin K.

K135—\$13

# INVERTERS

K138

**K**  
**SERIES**

NEMA

MIL

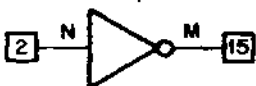
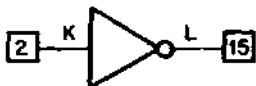
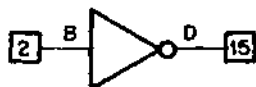

The K138 has eight inverter circuits on each module. These circuits can be used to invert other K Series outputs to obtain both a high (+5V) level as well as a low (0V) level. The K138 is pin compatible with the K134 and K135 and may be substituted for them if a higher density of inverters is desired.

K138—\$24

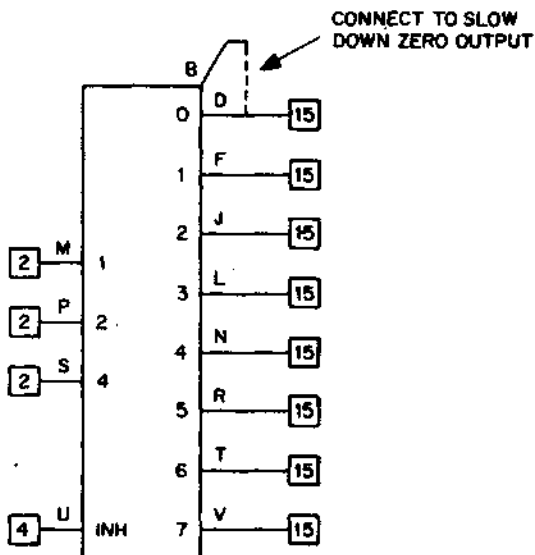
**BINARY TO OCTAL DECODER****K161****K  
SERIES****K161 DECODER**

Three-bit binary numbers at the input to the K161 will be decoded into eight one-at-a-time outputs. Both inputs and outputs are high for assertion. The inhibit input allows BCD to ten line decoders to be built, or permits several decoders to be interconnected for sixteen, twenty-four, thirty-two outputs, etc. The inhibit may be left open if unused, even though high is the inhibit state. When the K161 is being used with M series, all input signals must be buffered with K series gates. This is necessary due to the 3 volt thresholds in the K161.

Standard K Series slowdown circuits on each output minimize and for most purposes nullify the splinter pulses that all decoders emit during input transitions. Additional slowdown available on the zero output can usually suppress the larger splinter that may occur there. But since splinter size is ultimately determined by input timing tolerances, it is cleanest to avoid logic designs in which a decoder output is used as a source of pulses.

The diagrams below show how to connect decoders for 8, 10, 16 and 32 outputs. Much larger decoders are possible, and in fact up to 256 outputs or even more can be obtained by inhibiting all but one of several decoders.

---

**K161—\$25**

---



### 8 STATE DECODER

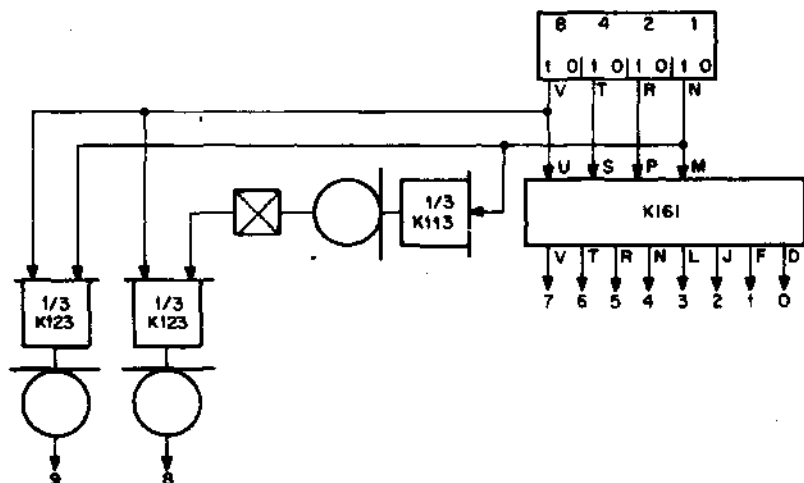
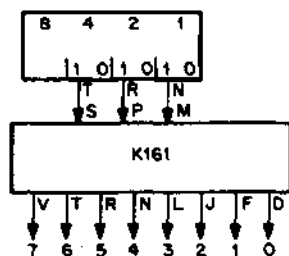

### BINARY-CODED-DECIMAL (BCD) DECODER

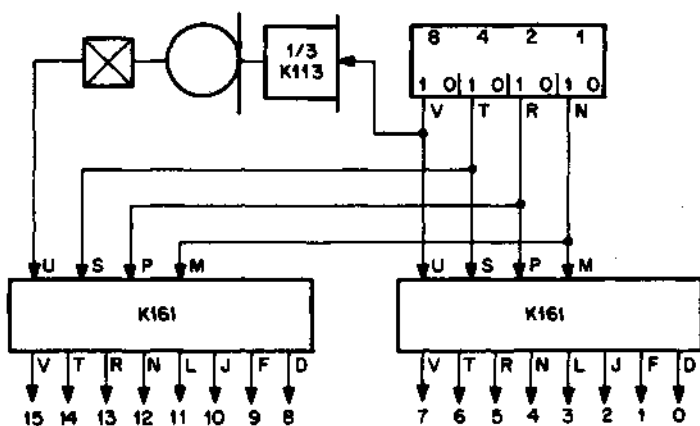

### 16 STATE DECODER

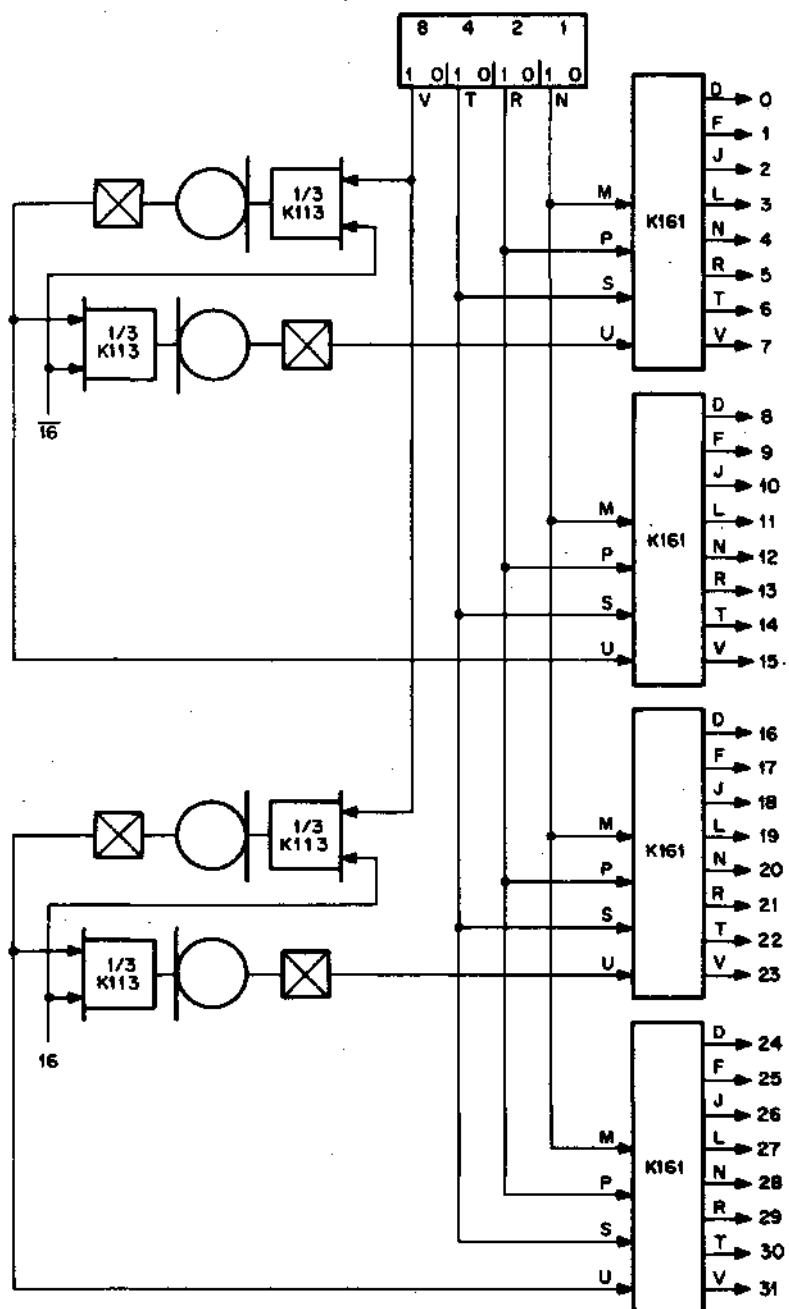

32 STATE DECODER

# EQUALITY COMPARATOR

K171

**K  
SERIES**

NEMA

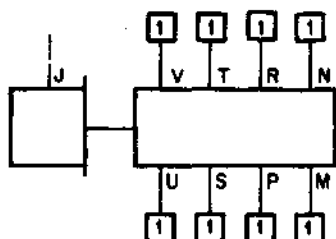

MIL

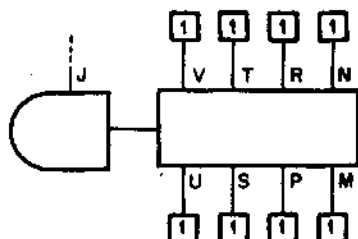

The K171 is a four bit equality comparator whose output at pin J is high if the two numbers being compared are equal. Pins N, R, T, and V are compared with pins M, P, S, and U. The output, Pin J, has no drive capability and must be connected to the AND expansion node of either a K113 or K123 logic gate.

More than 4 bits can be compared using any number of K171's, by tying all K171, pin J, outputs together at the same AND expansion node.

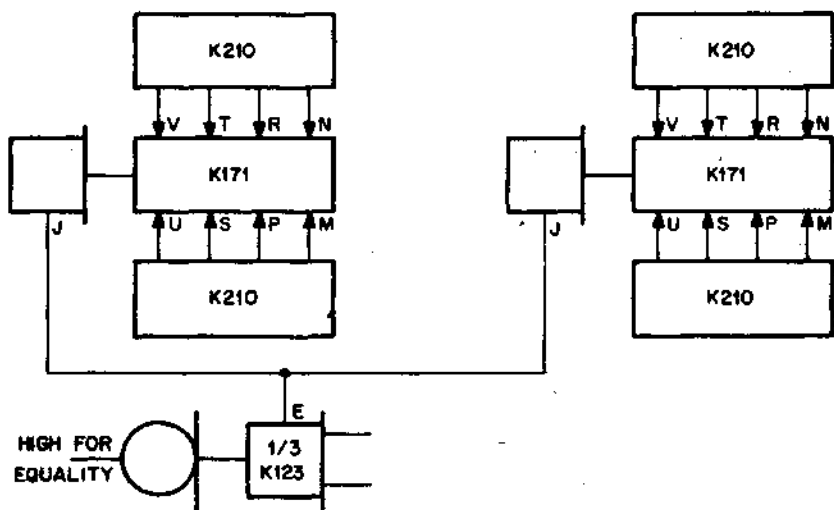

This module can be used in conjunction with the K174 to obtain the three independent outputs for greater-than, less-than, and equal-to.

K171—\$13

# DIGITAL COMPARATOR

K174

**K**  
SERIES

NEMA

OUTPUT TO  
COMPARATORS  
OF GREATER  
SIGNIFICANCE  
OR TO K113 OR  
K123 "OR"  
EXPANSION NODE

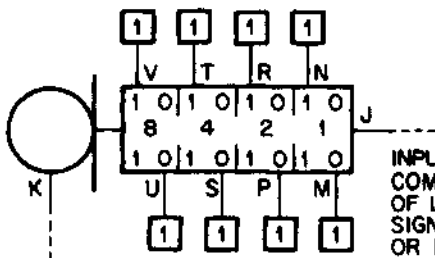

MIL

OUTPUTS TO  
COMPARATORS  
OF GREATER  
SIGNIFICANCE  
OR TO K113 OR  
K123 "OR"  
EXPANSION NODE

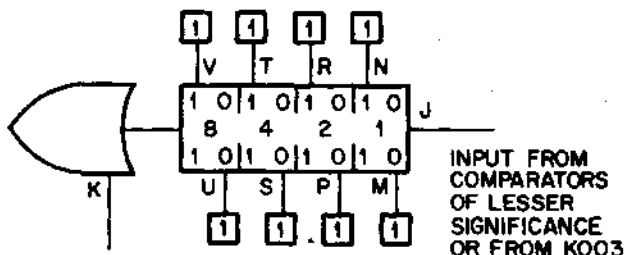

## K174 DIGITAL COMPARATOR

Numerical comparisons such as those required in digital positioning controls are facilitated by the K174. Performing the same function as the comparator in closed-loop analog systems, the K174 tells which of two quantities is larger.

Fundamentally, the K174 performs a subtraction to determine whether a "borrow" would be needed to obtain a positive result. The magnitude of the difference is not available; only the sign.

Note in the example below that the output on pin K will be low only if the magnitude of the number in the K210's is less than the thumbwheels.

If more than four bits are to be compared, several comparators may be cascaded as shown below. Note use of K003 as if expanding an "OR" to control the state of the output for the case of equal input numbers.

The output at Pin K would normally be low for equality without the K003 connected to Pin J, but with it connected, Pin K is high for equality as shown below.

K174—\$24

## TWO DIGIT COMPARISON OF THUMBWHEELS AGAINST K210, ETC.

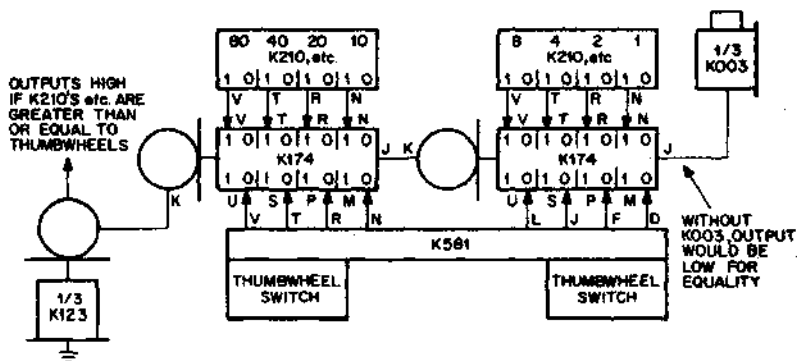

If the numbers being compared are not multiples of 4 bits then one of the inputs on each unused comparator position must be connected to +5 and the other one to the ground.

The K174 can also be used to obtain three independent outputs for full greater-than, equal-to, less-than capability. The application below takes advantage of the fact that if A is equal to B, K will go high if J goes high and K will go low if J goes low.

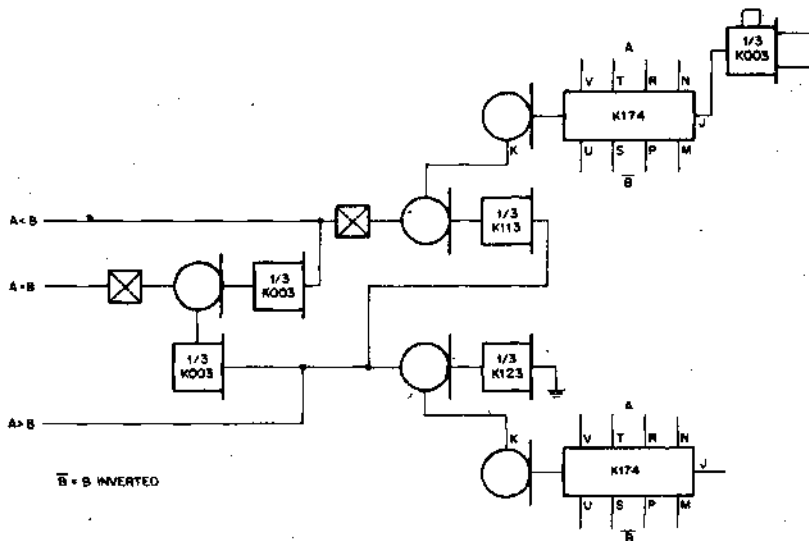

In certain applications, it is possible to make a single K174 oscillate if  $A=B$ . This is done by inverting the output at pin K and feeding it back to pin J.

# RATE MULTIPLIER

## K184

# K

## SERIES

NEMA

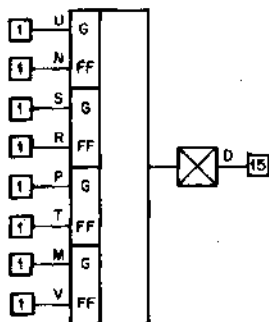

MIL

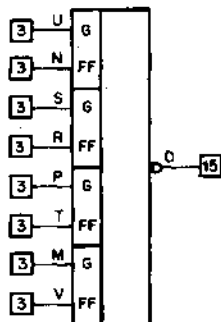

The K184 Rate Multiplier is basically a frequency multiplexer, although it has been used in several other applications. Pulse inputs of specific frequencies are wired to the FF inputs and a four bit binary fraction is presented in reverse order to the corresponding G inputs of the K184. Both sets of inputs produce an output pulse train which is a multiplexed combination of the pulse inputs provided. Each transition from "0" to "1" at an FF input produces a  $5\mu$  sec output pulse to ground if the corresponding G input has been high for  $5\mu$  sec or more.

Inputs are not rise-time sensitive and outputs from several rate multipliers may be combined to give any desired precision, pulse widths may be increased by connecting additional capacitors to pin J of the K184. Resistors must not be connected to this point.

Rate multipliers are primarily useful in numerical control applications, such as those described in the following magazine articles:

"Linear Interpolation" Control Engineering, June '64 p. 79

"Curvilinear Interpolation" Control Engineering, April '68, p. 81

"Many Digital Functions Can Be Generated With A Rate Multiplier" *Electronic Design*, Feb. 1, '68, p. 82.

In addition, the K184 can provide several other useful functions that take advantage of its internal complexities, shown below. Examples of both classes of use can be found among the applications notes.

K184—\$25

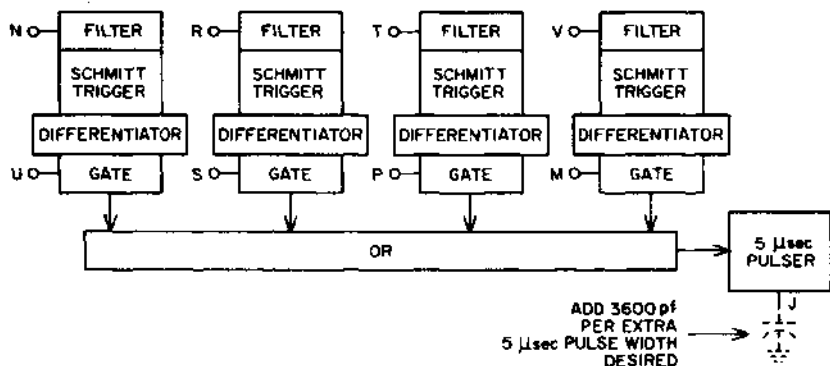

### LOGICAL EQUIVALENT OF K184 RATE MULTIPLIER

The following is an example of how the K184 operates using a K210 counter as a pulses input source.

The pin N output of a K210 will make a low to high transition for every other clock pulse the counter input makes. This means that its frequency will be  $\frac{1}{2}$  that of the count input  $f_i$ . The pin R output of the K210 pulses once for every four count inputs, giving it a frequency of  $\frac{1}{4}$  the count input  $f_i$ . The pin T and V frequencies are  $\frac{1}{6}$  and  $\frac{1}{6}$  of the count input frequency  $f_i$ .

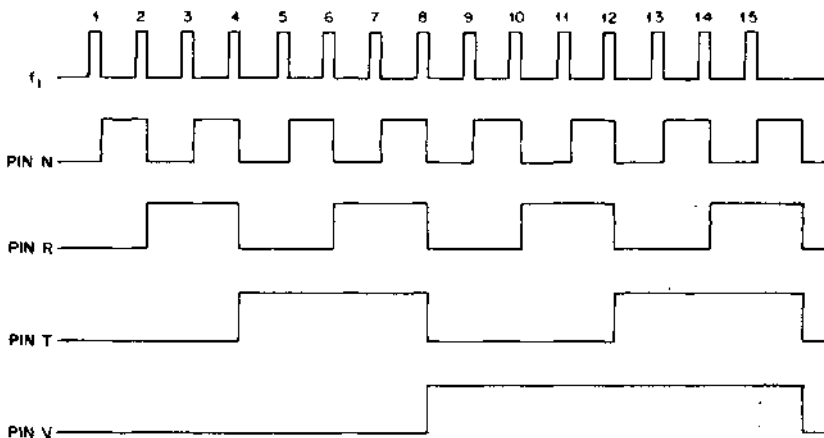

K210 BINARY-CLOCK COUNTER OUTPUTS GENERATED BY  $f_i$

If these K210 outputs are connected to a K184 as shown below, the frequency of the output of that K184, Pin D, can be programmed by selecting which G inputs will be high.

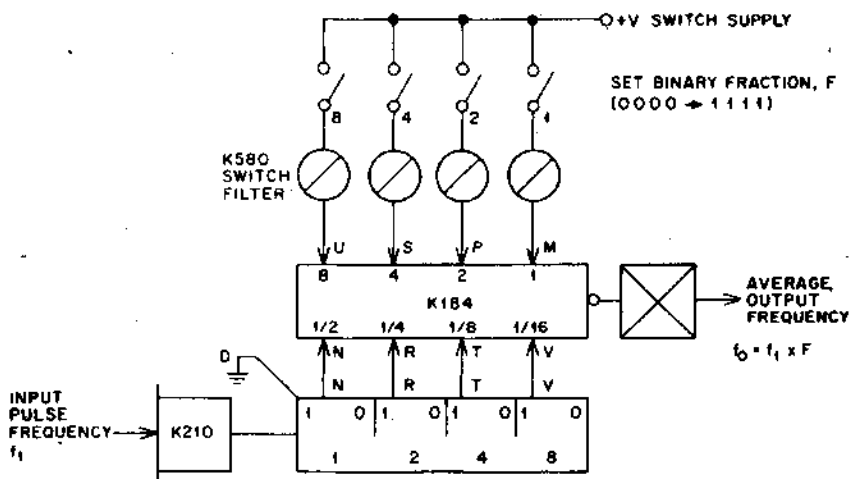

If just pin U is high then the output frequency  $f_o$  of the K184 will be  $\frac{1}{2}$  that of the K210 count input  $f_i$ . If pins U and S of the K184 are high then the output frequency  $f_o$  will be  $\frac{3}{4}$  ( $\frac{1}{2} + \frac{1}{4} = \frac{3}{4}$ ) that of the K210 count input  $f_i$ . The maximum frequency output  $f_o$  of a single K184 is  $\frac{15}{16}$  ( $\frac{1}{2} + \frac{1}{4} + \frac{1}{8} + \frac{1}{16} = \frac{15}{16}$ ) that of the K210 counter input. This maximum frequency occurs when all G inputs of the K184 are high (Pins U,S,P,M).



# FLIP-FLOP

## K201

# K

## SERIES

NEMA

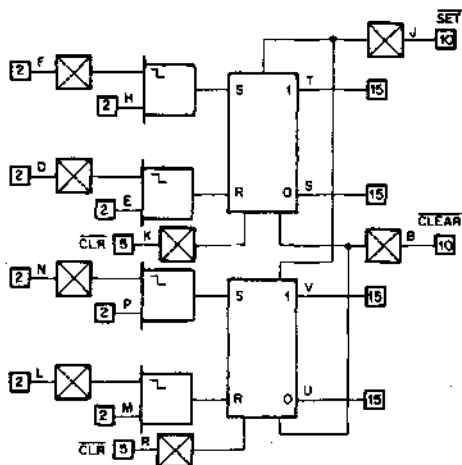

MIL

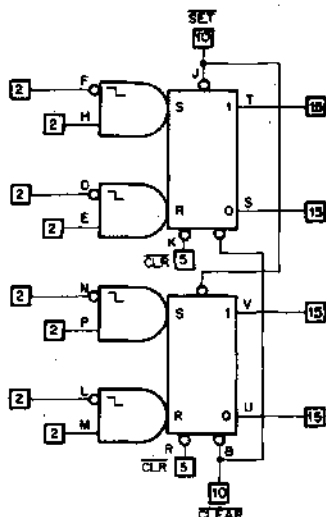

This superslow memory simplifies sequencing of machine motions, and finds other applications where the ultimate in noise isolation is needed and speed is no problem. Its 1 KHz maximum repetition rate makes this flip-flop noticeably more resistant to extremely noisy surroundings than faster types like K202, K210, etc. So noise immune, in fact, that several yards of wire may be connected to K201 outputs even in severely noisy areas without errors.

The K201 flip-flop input gating is designed to respond to the time sequence of two inputs rather than to their simple AND function. Level inputs E, H, M, and P must be high at least 400  $\mu$ s before the pulse inputs D, F, L, and N make a high to low transition. The flip-flop will compliment if the S and R inputs are pulsed at the same time. The input minimum noise rejecting time thresholds are 100  $\mu$ s. Successive input transitions must not be closer than 400  $\mu$ s. Grounding pin J causes pins T and V to go high and pins S and U to go low, regardless of the state of any other input except clear inputs.

Each flip-flop circuit on this module has a separate clear input (pin K and R). If either of these inputs is grounded the ZERO output of that specific flip-flop will go high and the ONE output will go low unless the set input is grounded.

There is also a common clear, Pin B, which when grounded, forces pins S and U high and pins T and V low, except when pin J is grounded.

If any clear input and the SET input pin J are grounded at the same time, the outputs will be undefined.

K201—\$39

# FLIP-FLOP

## K202

# K

## SERIES

NEMA

MIL

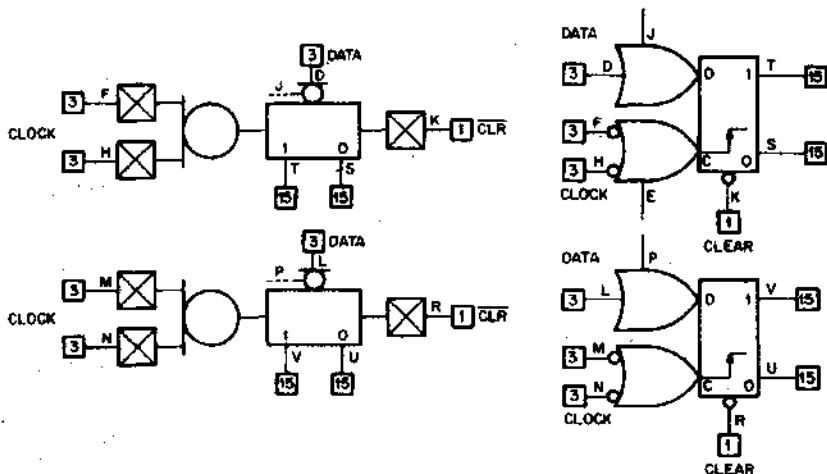

K202 flip-flops do shifting, complementing, counting, and other functions beyond the capabilities of simple set-reset flip-flops built up from logic gates. They also may be used to extend K210 counters or K230 shift registers.

When the output of the clock gate falls from high to low, the information at the OR input (pins D-J, L-P) is transferred into the flip-flop. Pin J (or P) is ORed with the pin D (or L) input. Like pins J and P of a logic gate, these pins can be driven only from a K003, K012, K028, or K026 expander.

Time is required for flip-flops and delayed inputs to adjust to new signals. The clock gate output must not fall to zero sooner than 4  $\mu$ sec after its own rise, the end of a clear signal, or a change on associated data input pins.

A K202 flip-flop is cleared by grounding the clear input pin. The flip-flop is held in the zero state as long as the clear input is zero volts, regardless of other inputs.

When using a K202 flip-flop to extend the length of a K230 shift register, pins B on both modules must be left open (unslowed). Pin B slows the clock inputs of the K202 for complementing correctly at slow speeds in very noisy surroundings; but the data inputs are not affected by pin B.

K202—\$27

**Complementing:** Below is shown a complementing application. Here the information stored at the data input is the opposite of the flip-flop's present state. Each time the clock gate output changes from "1" to "0", the opposite of the current state is read in.

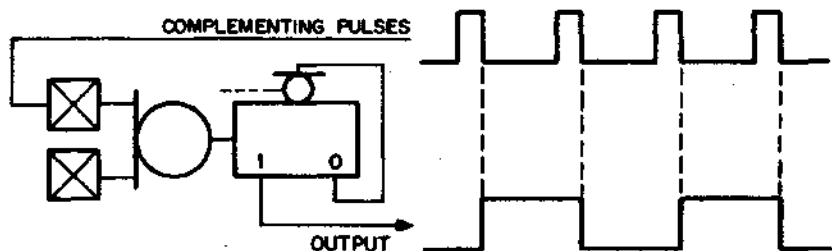

K202 COMPLEMENTING

**Shift Register:** The diagram below shows two flip-flops connected as a two-stage shift register. At each step the incoming signal, whether high or low, is set into the first stage of the register, and the original content of the first stage is set into the second stage. The input to each flip-flop must be stable for at least 4 microseconds before another shift pulse occurs, for reliable shifting.

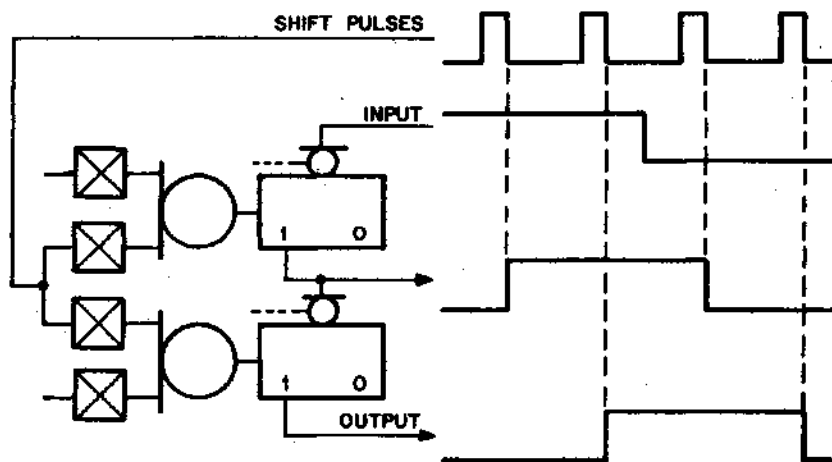

K202 2-STAGE SHIFT REGISTER

**Note:** In older systems of logic, most flip-flop functions had to be performed by general-purpose flip-flops like the K202. The K Series, however, includes functional types K210, K211, K220, and K230 which are both less expensive and easier to use than the K202 for most applications. Think of the K202 primarily as a complementing control flip-flop and register extender.

# FLIP-FLOP REGISTER

K206

**K**  
SERIES

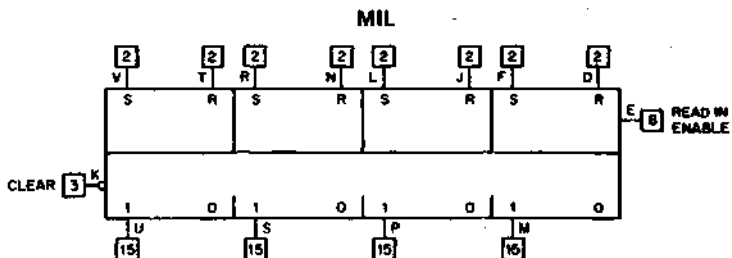
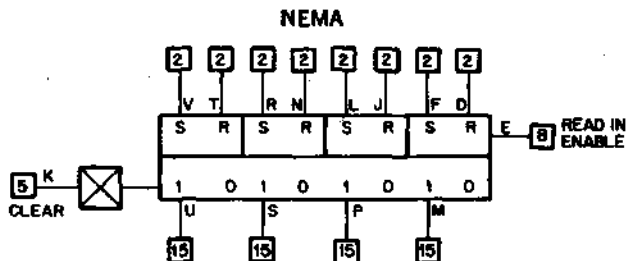

The four set-reset flip-flops in the K206 are arranged for convenient addressing from the outputs of a K161 Binary to Octal Decoder. The flip-flop outputs can then be wired to control and maintain the state of corresponding output drivers, providing addressable output conditioning from teletypes, computers, or fixed-memory sequence controllers.

In addition, the same decoder may be used to address a particular K578 input sampler by grounding the K206 enable input when flip-flop changes are not desired. Pin E enable fanin on the K206 is reduced to 2 milliamperes when K161 addressing is used.

Since most control systems have about half as many digital outputs as inputs, it is convenient to use the least significant bit of the K161 address to determine which flip-flop state is wanted. Odd addresses allow for setting; even addresses, resetting. All flip-flops may be reset together by grounding the clear input, pin K. This clear input takes precedence over all other inputs.

When pin E is high, a logic "1" at an S input will set the output to a logic "1" and a logic "1" at an R input will reset the output to a logic "0." S and R inputs should not be allowed to go high at the same time while the flip-flop is enabled. Any one or all flip-flops may be changed when pin E is high.

K206—\$20

**COUNTER**  
**K210**

**K**  
**SERIES**

NEMA

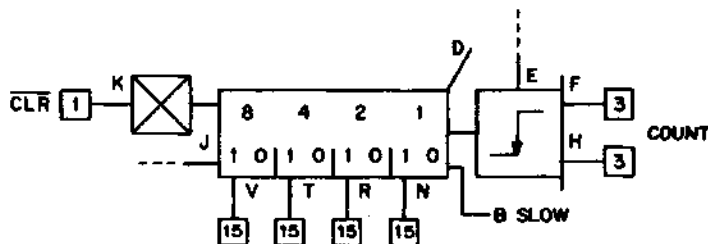

MIL

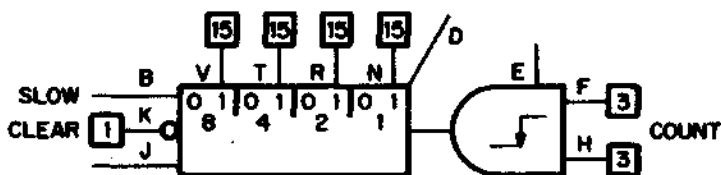

PL-0235

The K210 is a binary or BCD counter that can be wired to return to zero after any number of input cycles from 2 to 16. Count-up occurs when the COUNT gate output steps to zero. Decimal counting logic is built in; when pin D is unused, the counter resets to zero on the next count after nine. When pin D is grounded, the counter overflows to zero, after a count of 15. (Pin D is not intended for dynamic switching between binary and BCD counting.)

The counter is reset by grounding the clear input for 4 microseconds or more. A positive level at the J input from a K003 expander also resets the counter on the next high to low transition of the COUNT gate output. Counts of 10 or 16 DO NOT require the use of a K003 expander since they can be obtained with pin D.

Wire the K003 as a decoder to detect one count less than the desired modulus. (Detect 5 for a count-of-6 counter, etc.). Use the K424 Thumbwheel Decoder if manual reset control is desired.

K210—\$27

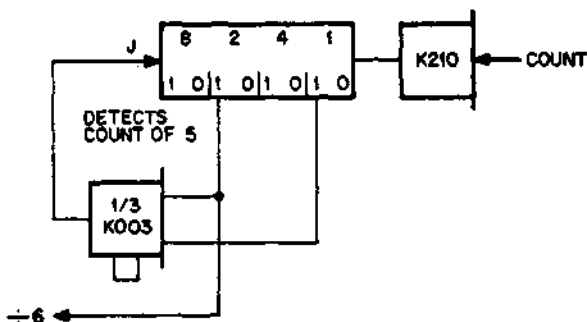

K210 CONNECTED FOR COUNT OF 6

To count above 10, ground pin D. Combine two K003 expanders as shown below, where three counter outputs must be sensed (to divide by 8, 12, 14 or 15).

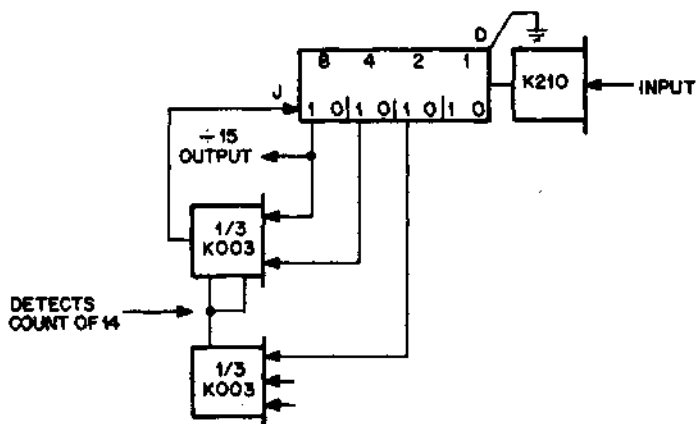

K210 CONNECTED FOR COUNT OF 15

Time is required for flip-flops and pin J reset logic to adjust to new inputs. The count gate output must not step to zero sooner than  $4.0 \mu\text{sec}$  after its own rise, a change at pin J, or the end of a clearing signal at pin K. When pin B is grounded for slowdown, allow  $50 \mu\text{sec}$ .

Larger counters are obtained by cascading K210's or adding K202 flip-flops. To cascade K210 modules, wire the most significant output of one counter to the input gate of the next. Inputs to the least significant stage can be either pulses or logic transitions to ground; risetime is not important.

Any transducer such as a switch, photocell, pulse tachometer, thermistor probe, or other compatible with K508, K522 or K524 input converters can

generate the signal which is to be counted. The lack of input risetime restrictions may allow transducer outputs to drive K210 counters directly if damaging transients can be avoided, as when the transducer shares the logic system environment.

For visual readout of binary-coded decimal counters, the four outputs from each K210 may be connected to corresponding input pins on a K671 decoding driver and display.

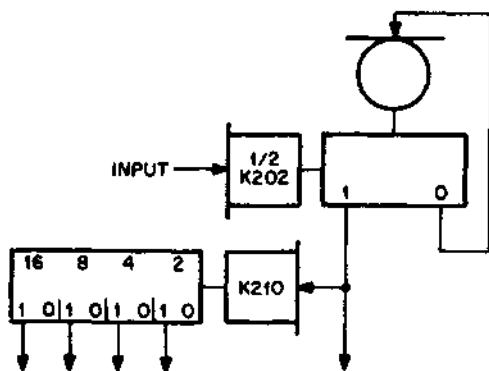

K210 AUGMENTED WITH K202 FOR COUNT OF 32

**PROGRAMMABLE DIVIDER**  
K211

**K**  
**SERIES**

NEMA

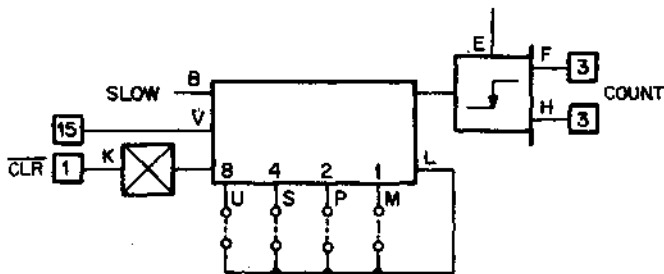

MIL

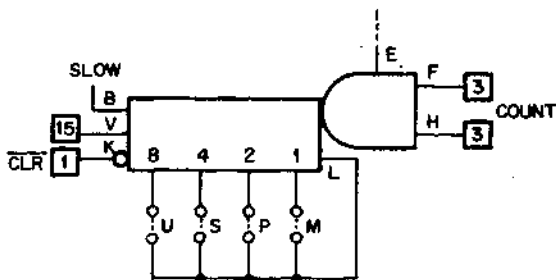

The K211 is a binary counter that can be wired to produce a high to low output transition on pin V after any number of input cycles from 2 to 16. Count-up occurs on the high to low transition of the count gate output.

The counter is programmed by connecting pin L to pins M, P, S, and U to select the binary number that is one count less than the desired modulus. (Detect 2 for a count-of-3 counter, etc).

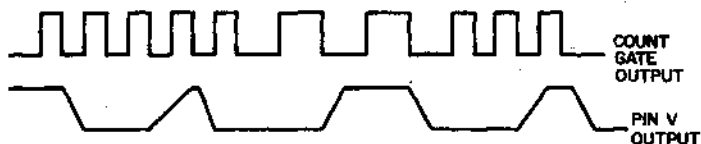

Modulo 3 counter

Pin L is connected to pin P only.

K211—\$20



The counter is reset by grounding pin K for 4 microseconds or more. Time is required for flip-flops to adjust to new inputs. The count gate output must not step to zero sooner than 4.0  $\mu$ sec after its own rise or at the end of a clearing signal at pin K. When pin B is grounded for slowdown, allow 50  $\mu$ sec.

Larger dividers can be obtained by cascading K210's, K211's or adding K202 flip-flops. To cascade K211 modules, wire pin V to the input gate of the next module. Inputs to the least significant stage can be either pulses or logic transitions to ground; risetime is not important. Any transducer such as a switch, photocell, pulse tachometer, thermistor probe, or others compatible with K508, K522, or K524 input converters can generate the signal which is to be counted. The lack of input risetime restrictions may allow transducer outputs to drive K211 modules directly if damaging transients can be avoided, as when the transducer shares the logic system environment.

K211 modules can be used to build real time clocks and frequency dividers when only the most significant output is required.

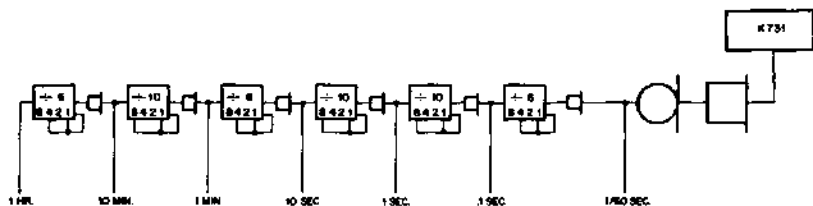

REAL TIME CLOCK

**UP/DOWN COUNTER**  
K220

**K**  
**SERIES**

NEMA

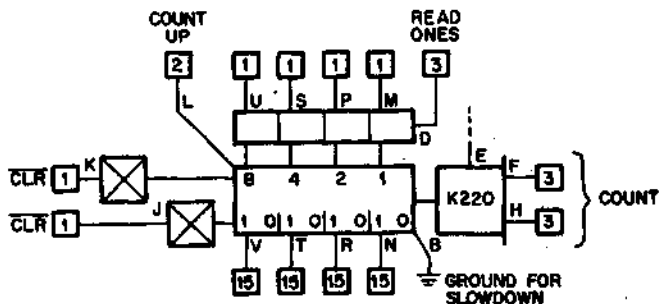

MIL

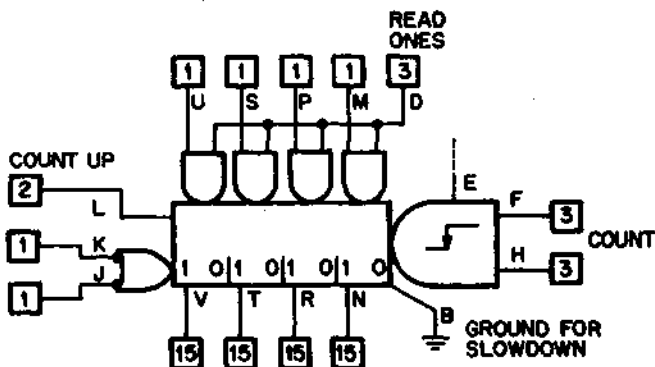

(DOUBLE HEIGHT BOARD)

The K220 Counter module provides all the circuitry necessary for binary and binary coded decimal up counting, down counting, presetting and clearing. This module is useful in many digital position readout and feedback applications.

K220—\$55

The K220 is a double height module with all but two pin connections made on the upper connector (pins D and E on the lower connector must be grounded for binary UP/DOWN counting).

The direction of counting is established by the signal at pin L, high for up counting and low for down counting. Pin L count direction changes should finish no later than 4.0  $\mu$ sec. before the next count input. Up counts occur when the count (AND) gate output makes a transition from high to low (+5v to 0v). Down counts take place on the count gates output transition from low to high (0v to 5v).

To preset the outputs of a K220, four read-in flip-flops with a common enable have been provided in the circuit. High logic levels (+5v) present at the read-in gate pins (U,S,P, or M) are read into their respective flip-flops when the common enable pin D, makes a low to high transition (0v to 5v). These preset flip-flops will not read low levels (0v) into the K220. All unused read-in gate inputs should be grounded to prevent the read-in of undesired ONE's.

The K220 outputs can be cleared to zero by grounding pin J or K. During this clearing process, no count or preset input can be read into the module; clearing inputs take precedence over all others.

With the exception of the clear inputs, time is required for flip-flops, counting logic, and read-in gates to adjust to new inputs. To prevent counting errors, neither the count gate output nor any other counter input should change within 4.0 microseconds of a transition at any other input.

For slowdown operation, pin B of the K220 must be grounded. If slowdown is used, 50 microseconds must be allowed between one counter input transition and an input transition at any other input.

When K220 counters are cascaded, a single connection from pin V of one K220 to the count input gate of the next, establishes both carry and borrow propagation.

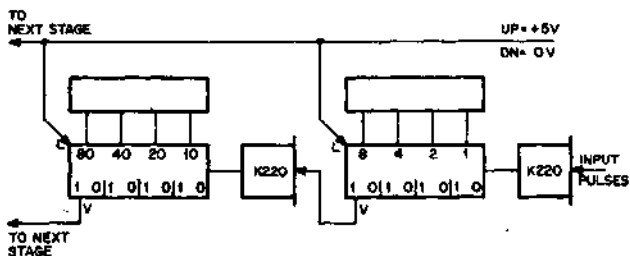

Shown below is a means of acceptance up and down pulse-trains from two separate sources. For this application, input pulse spacing should be at least 20 microseconds and input pulse widths should be at least 10 microseconds.

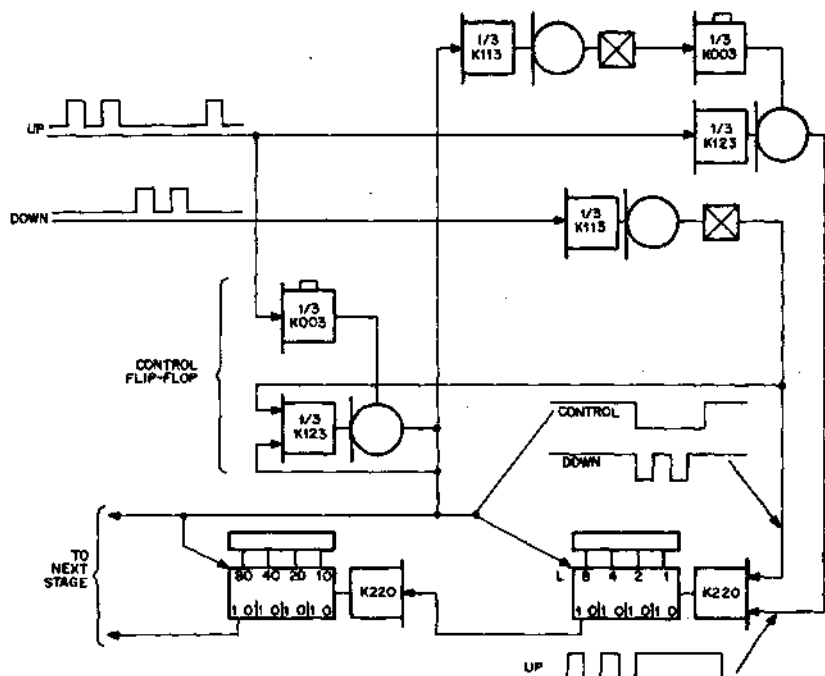

### UP/DOWN COUNTER FOR SEPARATE PULSE SOURCES TO 50Kc

The "clear" and "read ones" inputs on the K220 module may be combined to transfer completely new data into the module in a single operation. Timing requirements in the K220 demand that a low to high transition on the "read ones" (PIN B) input wait until at least 4 microseconds after the clear input rises. A simple method of accomplishing this delay follows.

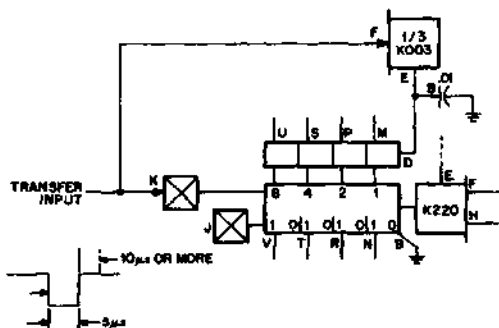

This circuit gives approximately 10 microseconds of rise delay. The delay may be reduced to about 5 microseconds if desired, by connection another one milliamper pull-up (pin D to pin E on the K003).

Several "read ones" inputs may be driven from a single K003 section, provided the capacitance is multiplied by the number of inputs driven. Heavy capacitive loading may cause slow falltimes on the transfer input line. Pin D inputs on the K220 may be regarded as 1 milliampere loads in this application.

The transfer input rise time must be from an unslowed K Series output. Slow signals from K580, K581 or K578 modules must be accelerated by a K501, Schmitt Trigger.

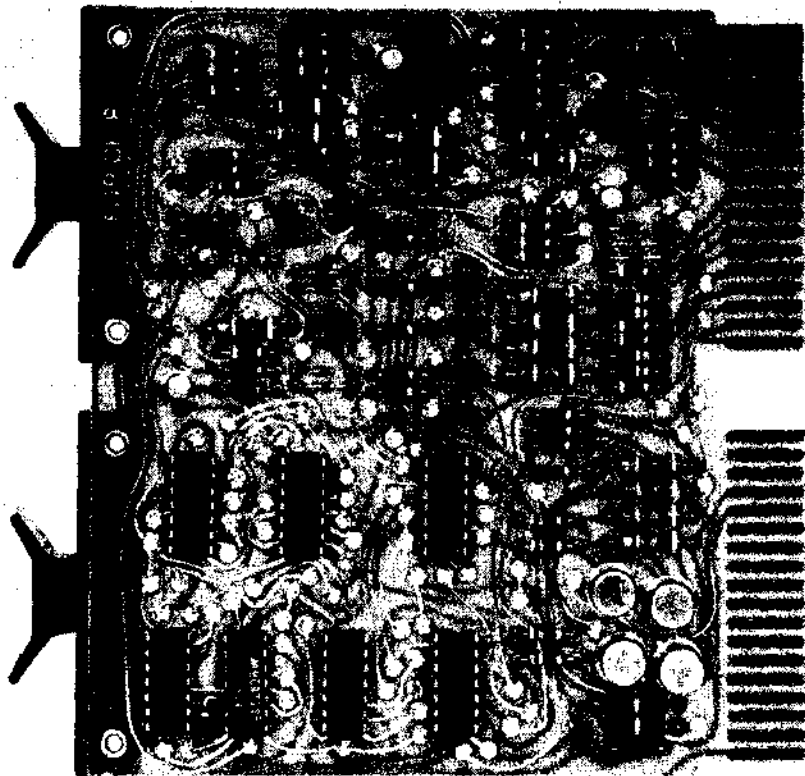

K220 UP/DOWN COUNTER

# SHIFT REGISTER

## K230

# K SERIES

NEMA

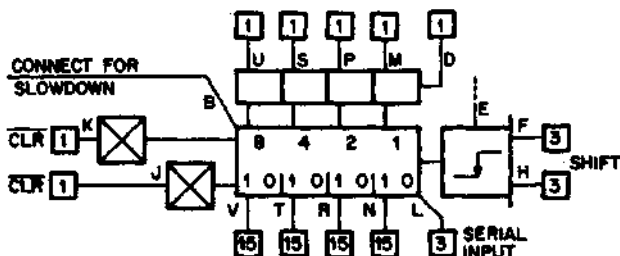

MIL

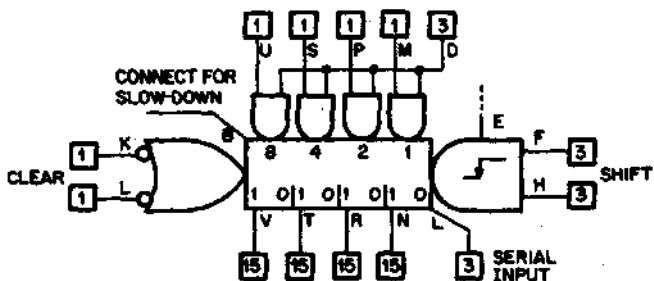

(DOUBLE HEIGHT BOARD)

Information presented at pin L of this four stage flip-flop register is shifted toward pin V with each high to low transition (5v to 0v) at the shift input gate.

To preset the outputs of a K230, four read-in flip-flops with a common enable have been provided in the circuit. High logic levels (+5v) present at the read-in gate pins (U,S,P, or M) are read into their respective flip-flops when the common enable pin D, makes a low to high transition (0v to 5v). These preset flip-flops will not read low logic levels (0v) into the K230. All unused read-in gate inputs should be grounded to prevent the read-in of undesired ONE's.

K230—\$40

The K230 outputs can be cleared to zero by grounding pin J or K. During this clearing process, no count or preset input can be read into the module; clearing inputs take precedence over all others.

Shift registers of any length can be formed by tying pin V of one K230 to pin L of the next, and operating all shift gates together. Supply all shift pulses from the same device to maintain synchronism. The propagation delay of even one gate is too large a difference between two shift inputs on the same register. For every 20 bits that are required, duplicate the last stage of the shift-generating logic and tie the outputs in parallel to all K230 shift gate inputs.

Time is required for flip-flops, shifting logic, or read-in gates to adjust to new inputs. Except clear inputs, neither the shift gate output nor any other register input may be changed within 4  $\mu$ sec. after a transition at any other input. When pin B is grounded for slowdown, allow 50  $\mu$ sec.

# SET-RESET RETENTIVE MEMORY

K271

**K**  
SERIES

NEMA

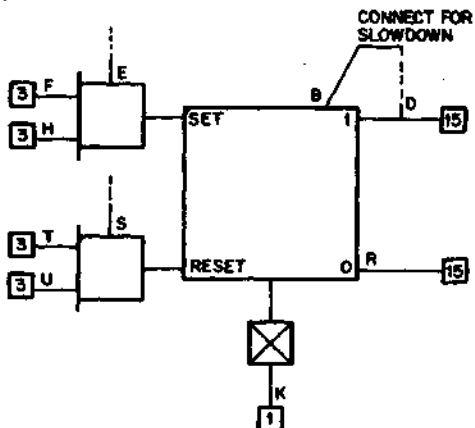

MIL

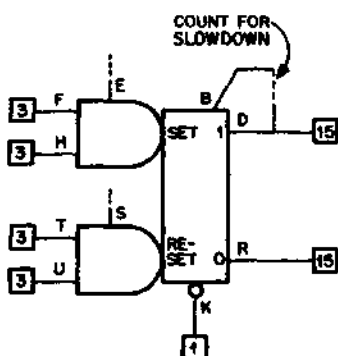

DOUBLE THICKNESS

The K271 is a magnetically latched mercury wetted contact relay flip-flop. A logic one output from the SET gate will set the flip-flop, and a logic one output from the RESET gate will reset the flip-flop. The state of the memory

K271—\$40



will be unknown if the SET and RESET gate outputs are both logic one at the same time. Since time is required for the relay to change state, inputs must be high for at least five milliseconds.

Pin K must be held low or the memory can not be set or reset. Normally, the OK level output from a K731 or K730 source module drives pin K. When a line voltage failure is detected, pin K rises and the relay mechanically stores the last valid data until full power returns. Logic design must be provided for pin K to ensure that it remains high after power is restored until the system has returned to its proper state.

The maximum angle from the vertical, shock, and vibration specifications for the bistable mercury wetted contact relay are as follows:

**SHOCK:** 30 G's for  $11 \pm 1$  milliseconds duration

**VIBRATION:** 0.6" Double Amplitude or 10 G's peak acceleration, whichever is less, 10-500 Hz.

Maximum angle from vertical of 30°.

# RETENTIVE MEMORY K273

# K SERIES

## NEMA

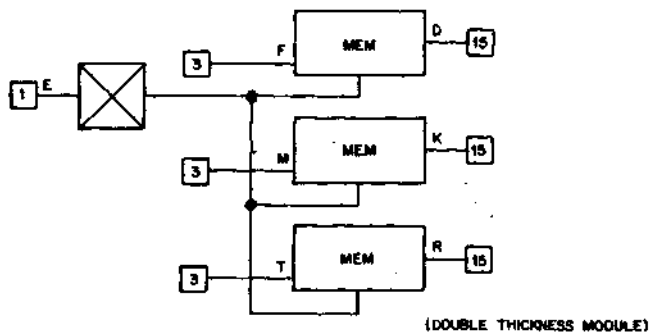

## MIL

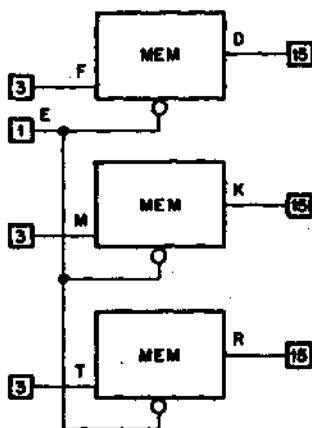

Three magnetically latched mercury wetted contact relays in the K273 follow logic-level input information at rates up to 100 Hz, when pin E is grounded.

Normally the OK level outputs from either a K730 or a K731 source module drive pin E. When a line voltage failure is detected, pin E rises and each relay

K273—\$85

mechanically stores the last valid input data until full power returns. Logic design must be provided for pin E to ensure it will remain high after power is restored until the system has been returned to its proper state.

The maximum angle from the vertical for which the K273 will operate properly is 30°. Shock and vibration specifications for the bistable mercury wetted contact relays are as follows:

**SHOCK:** 30 G's for  $11 \pm 1$  milliseconds duration

**VIBRATION:** 0.06" Double Amplitude or 10 G's peak acceleration, whichever is less, 10-500 Hz

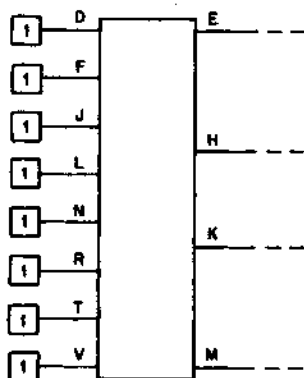
**FIXED MEMORY****K281****K  
SERIES****K281 FIXED MEMORY**

The K281 is designed to be used with the K161 (Binary to Octal Decoder), the K681 (8-30 ma drivers) and the K134 (4 inverters), to build a read-only memory. Each K281 initially contains eight four-bit words consisting of only "1's". The user selects the codes he desires by cutting out diodes in the bit positions that are to be "0's". Additional K281 and K134 modules may be added to the system to generate more words and longer words. See Application Notes for diagram of memory configuration.

---

**K281—\$10**

---

### CODING THE K281 DIODE MEMORY

When the K281 is used to build a K Series Read Only Memory, the codes are stored by cutting out diodes where zeros are desired. The diode map below shows the physical location of the diodes on the K281 and how they are connected to the module pins.

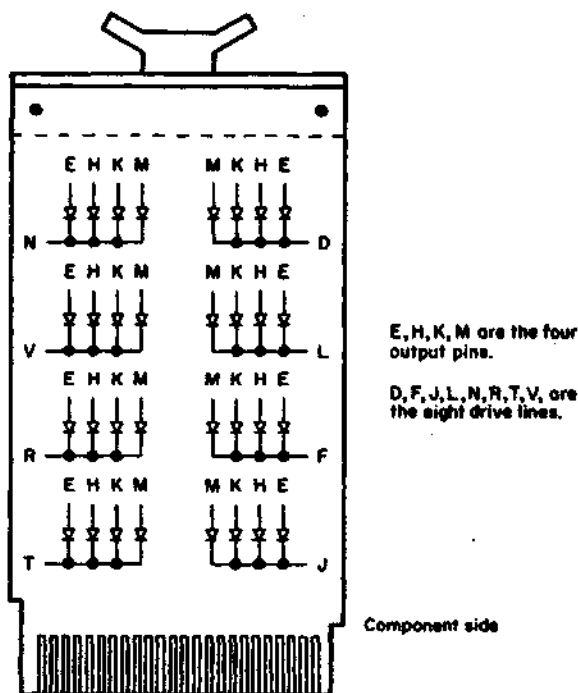

# DIODE MEMORY

K282

**K**  
**SERIES**

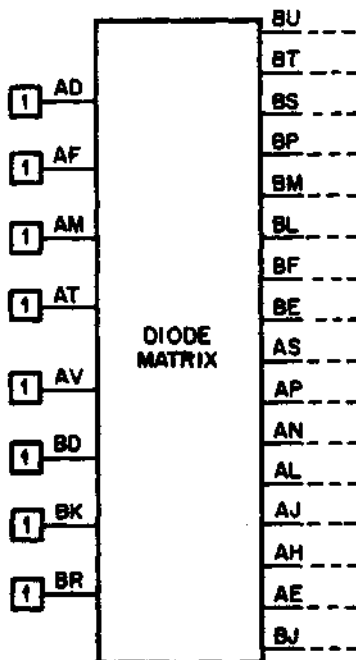

K282

The K282 is a diode matrix module which initially contains eight, 16-bit words. This matrix was designed to be used with K134 modules to obtain read-only memories. The user selects the codes he desires by cutting out diodes in the bit positions. More bits may be added by using additional K281 or K282 modules.

K282—\$40

**BASIC TIMER**  
K301

**K**  
**SERIES**

NEMA

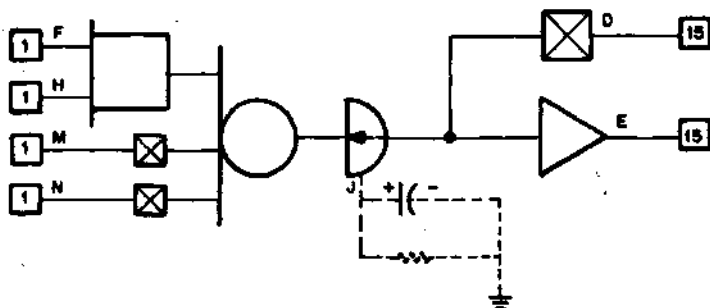

MIL

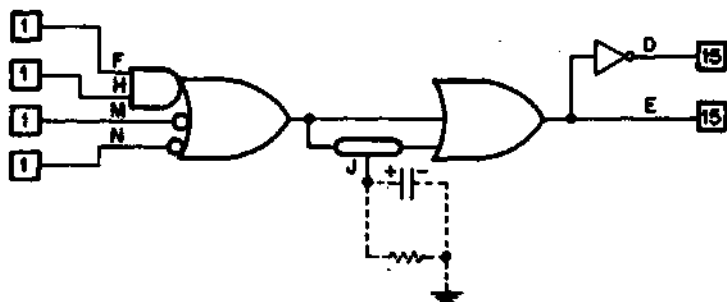

The K301 Basic Timer can be used as an OFF DELAY (like the K303), ON DELAY or ONE SHOT (like the K323). Time delays from ten microseconds to 30 seconds can be obtained with either fixed or adjustable delays. Calibrated controls are available (K374, K376 and K378) for mounting directly on the K301. Remote controls can be added if desired. Mounting holes are provided on the module for different size timing capacitors and a trimpot or fixed resistor.

The output delay is controlled by the value of R and C connected to pin J. The timer recovery begins when either pin M or N is low or both F and H are

K301—\$15

high. Allow a recovery time of at least  $300C$  ( $C$  in farads), in order to guarantee 95% repeat accuracy in timing. The timer delay period is equal to  $.7 RC$ . Any value of  $C$  may be used as long as  $R$  remains between 1 K and 250 K ohms. The following diagrams demonstrate how the K301 may be used to provide different types of timing. Pins  $P$  and  $C$  must be connected together to form the one shot circuit.

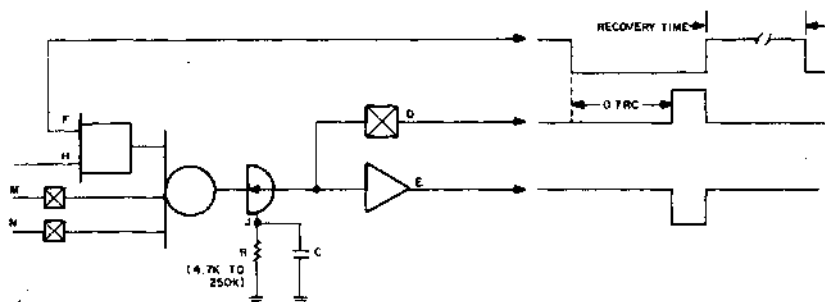

**OFF DELAY (like K303)**

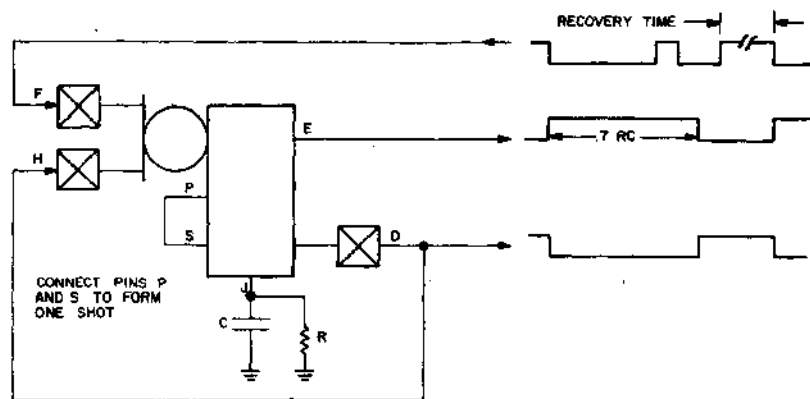

**ONE SHOT (like K323)**

A positive pulse at the input will not terminate the time out if the inverted output is connected to one input of the one shot. Pins  $M$  and  $N$  should be left open.



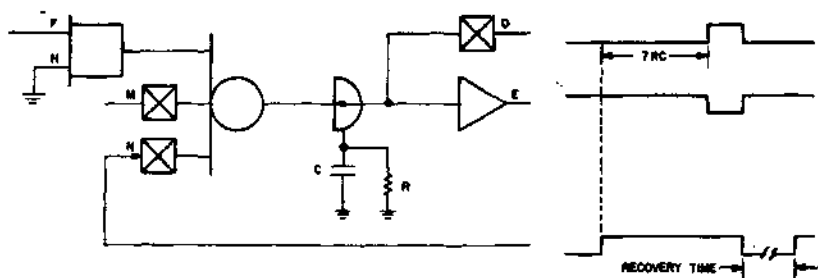

ON DELAY — K301

The K301 circuit is similar to the K303 Timer and uses the same techniques of noise rejection. For further information on resistors, capacitors and construction recommendations for external pulse width controls, please refer to the K303 module and K371-K378 timer controls.



K301 TIMER

# TIMER K303

# K SERIES

NEMA

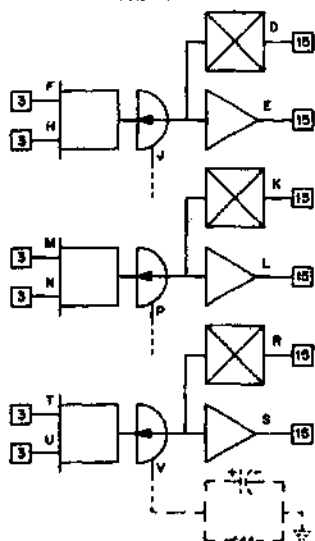

MIL

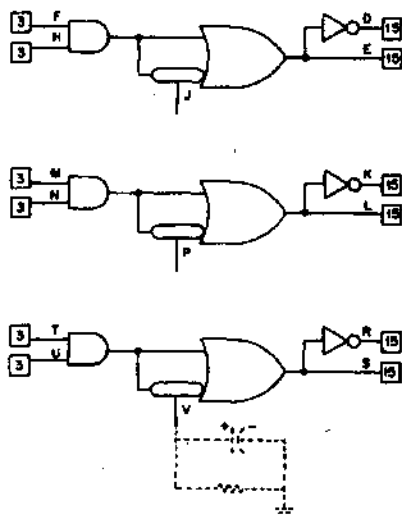

K303 timers provide time delays from 10 microseconds to 30 seconds and can be interconnected to form clocks with periods covering the same intervals. Fixed or adjustable delays and frequencies are obtainable. Calibrated controls are available (K371 through K378) for mounting directly on the K303. Remote controls can be added, if desired. A simplified schematic of the K303 is shown below. Note that the comparator has hysteresis, increasing the rejection of false "1" noise peaks at the input.

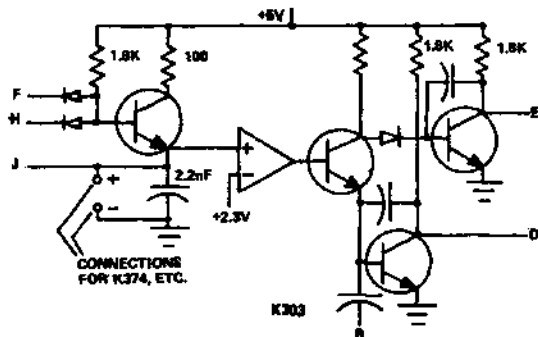

K303 TIMER SIMPLIFIED SCHEMATIC

K303—\$27

When a K303 input gate steps to zero, the uninverted output falls after a controlled interval, while the inverted output rises. The interval can be as little as 10  $\mu$ sec or as long as 30 seconds depending on the size of the R and C connected to pin J, P, or V. Recovery begins when the input gate output rises to a logic "1". In order to guarantee 95% repeat accuracy in the delay time, a recovery time of at least 300 C should be used, (C is in Farads, Time is in seconds). Be sure to include the 2.2 nf capacitor as part of the value for C. The delay interval in seconds is equal to .7RC (R in ohms, C in farads).

Any value of C may be used as long as R remains between 1 K and 250 K ohms.

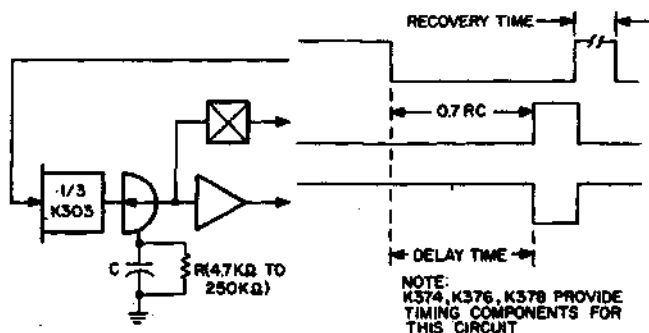

### 1/3 K303 AS OFF DELAY

A positive step at the input gate output resets the K303 timer outputs. If the step occurs before a timeout is complete, the timeout is terminated and no change appears at the outputs. This property is sometimes convenient for establishing a pulse repetition rate threshold (Frequency Setpoint).

A built-in 2.2 nanofarad timing capacitor assures adequate noise rejection when external capacitors are mounted several inches from the timer. Time threshold for resetting is always several percent of rated recovery time, so that noise rejection time increases in proportion to the size of the timing capacitor. Remote rheostats and timing capacitors may be used, but noise rejection will be degraded. If several timing capacitors will be switch selected, wire in the smallest near the module and switch the others in parallel with it.

Variable or fixed timing resistors used with K303 timers may be any carbon composition, film, or wirewound rheostat or potentiometer. Delay time is linearly proportioned to resistance from 250K $\Omega$  down to a few thousand ohms, falling to zero (reset inhibited) below a few hundred ohms. Momentary shorting to ground of control pins will not cause damage, but a padding resistor of at least 300 $\Omega$  in series with variable controls is advisable both to prevent continuous grounding and to avoid confusion which may arise if resetting is inhibited.

Timing capacitors may be any ordinary mica, paper, ceramic, or low leakage electrolytic type. For delays above a few seconds, wet slug tantalum electrolytic capacitors are advisable to avoid leakage-induced drift at high temperatures. Temperature coefficient of delay has been optimized for the carbon composition potentiometers and tantalum electrolytic capacitors used in the controls described below, and is typically less than  $\pm 1\%$  in 5 $^{\circ}$ C (9 $^{\circ}$ F) using K731 and K732 regulators for power.

# ONE SHOTS

## K323

# K SERIES

NEMA

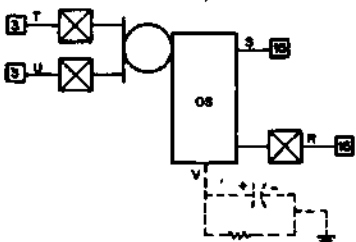
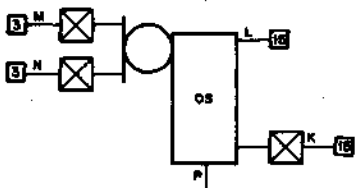
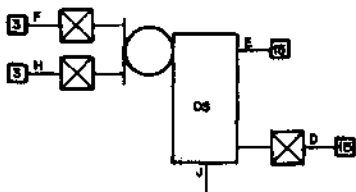

MIL

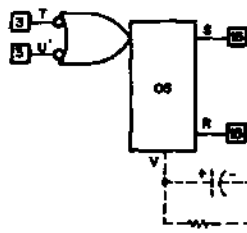
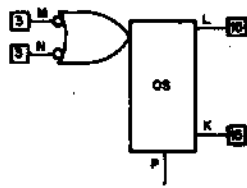
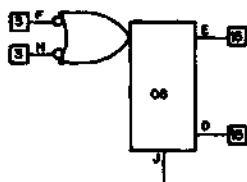

K323 one shots provide output pulse widths from 10 microseconds to 30 seconds with either fixed or adjustable delays. Calibrated controls are available (K374, K376 and K378) for mounting directly on the K323. Remote controls can be added, if desired.

When either input to the K323 gate steps to zero the uninverted output rises and stays positive for a time equal to  $.7 RC$ . The pulse width is controlled by the value of R and C connected to pin J, P, or V. C can be any value, but R should be between 1 K and 250 K ohms. The one shot recovery begins when both signals at the input gate rise to logic 1. A recovery time of at least 300 C should be allowed to ensure 95% repeat accuracy in the output pulse width. (C is in farads, R is in ohms, time is in seconds).

K323—\$35

When both signals at the input gate are high, the uninverted output is forced low. If this occurs before a timeout is complete, the timeout is terminated and the pulse width will be unknown. This premature resetting can be eliminated by connecting the inverted output (pins D,K, and R) of the one shot to one of its inputs. This will make the one shot insensitive to input transitions during the timeout period.

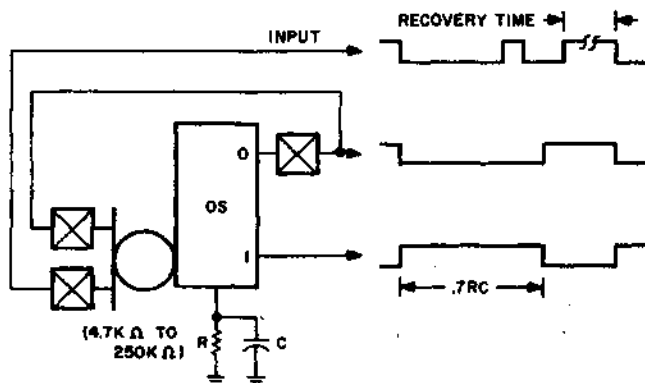

A positive pulse at the input will not terminate the timeout if one input is connected to the oneshot inverted output (either pin D,K, or R).

The K323 circuit is similar to the K303 Timer and uses the same techniques of noise rejection. For further information on resistors, capacitors and construction recommendations for external pulses width controls, please refer to the K303 module.



K303 TIMER

# PULSERS

## K333

# K SERIES

### NEMA

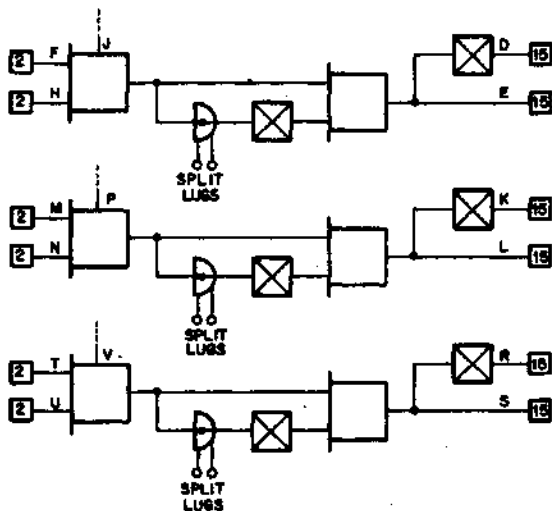

### MIL

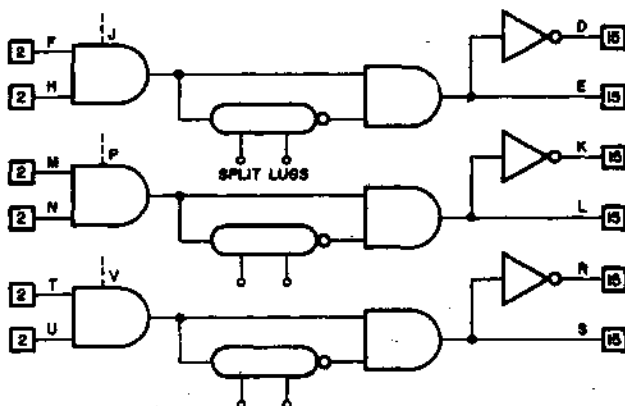

The K333 Pulsers circuits are designed to produce pulses from low to high level transitions. The length of a pulse is determined by the capacitance connected to split lugs conveniently mounted on the module.

K333—\$23

Without a capacitor connected to the split lugs, the K333 Pulser circuits give a 10 to 15 microsecond pulse. For each .001  $\mu$ f capacitor connected to the split lugs, the pulse width increases by approximately 10 microseconds. A minimum recovery time ( $T_R$ ) of  $2000C$  seconds, where  $C$  is the value of the capacitance used, should be allowed to ensure 95% repeat accuracy in the output pulse width. All inputs to these circuits must be longer in duration than the output pulse widths desired. Complimenting outputs are also provided on each circuit.

Typical outputs for a given input are shown below:

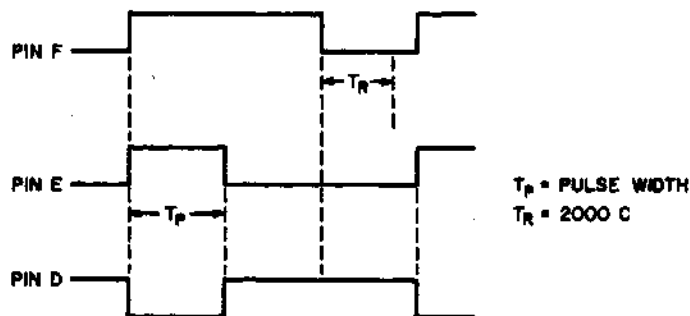

Hysteresis at the inputs makes it possible to use the outputs of the K578, K580 and K581 modules as inputs. The AND expansion node may be used with a K003 to generate pulses from a counter. Even though each pulser may have a different timing capacitor, it is recommended that all circuits be given the same width on all modules so that modules may be interchanged without creating logic timing problems.

# TIMER CONTROLS

## K371, K373, K374, K375, K376, K378

# K SERIES

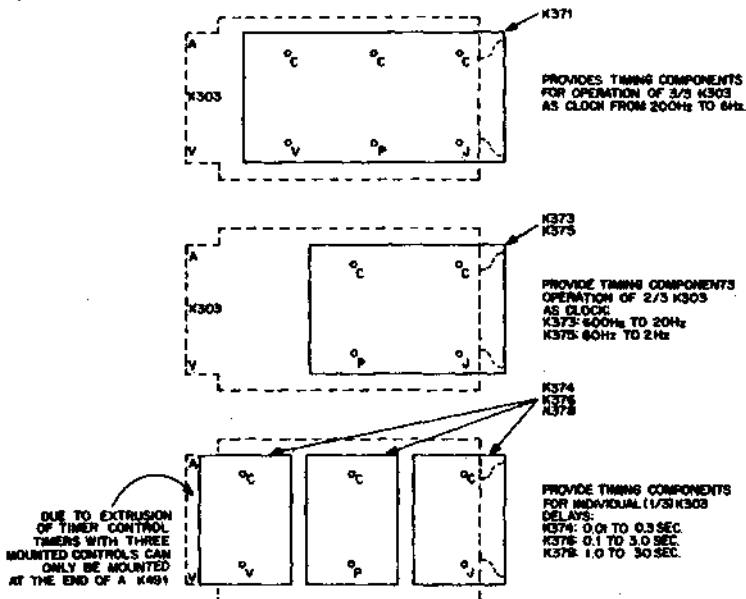

Calibrated controls for timers, one-shots, and clocks are available in several ranges. They mount to the K301, K303, or K323 module on the side opposite the components by two screws per circuit, providing both mechanical and electrical connections. Each control includes a logarithmic potentiometer for easy setting over the full 30:1 calibrated range. Calibrations are approximate, meant for quick setup and easy control identification. Accurate time settings require the use of an oscilloscope, stopwatch, or other reliable time standard. These controls are intended for use at the end of K941 mounting bars. When three timer controls are mounted on a single timer board, the module cannot be mounted in any connector block except one at the end of a K941 mounting bar. This is due to the extrusion of one timer control over the connector pins.

**Note:** Time delay jitter is proportional to supply voltage ripple if times of the order of 1 msec are selected. For critical applications, use light loading on separate K731 or use H710 supply.

K371	—\$11
K373	—\$11
K374	—\$15
K375	—\$11
K376	—\$15
K378	—\$15



### TIMER K303

Two K303 sections can be interconnected to make a free-running oscillator if one of the timing capacitors is about 100 times smaller than the other. The circuit with the larger capacitor will predominantly control the frequency. The diagram below shows the interconnections.

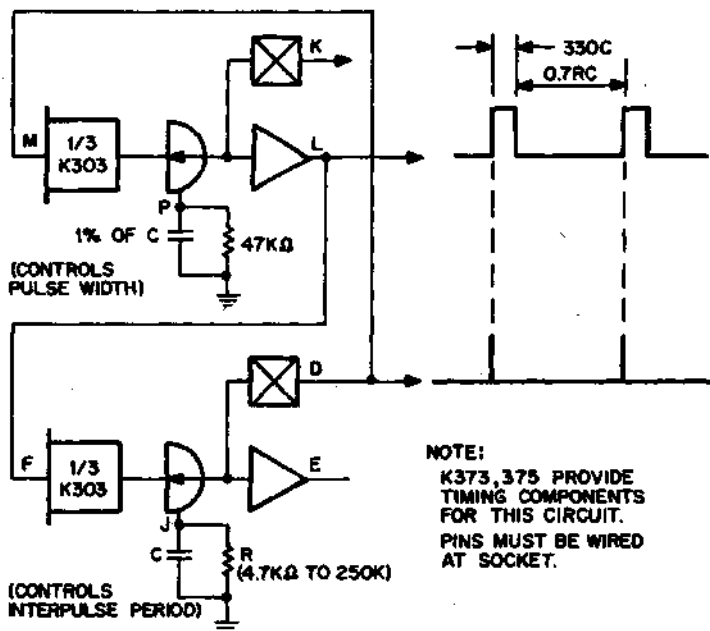

2/3 K303 AS CLOCK BELOW 1 KHz

The 100 to 1 ratio of timing capacitors required limits this method to frequencies to 1 KHz or less, due to the 2.2 nanofarad capacitor built into each circuit. Three K303 circuits may be connected together for higher frequencies, as shown on next page.

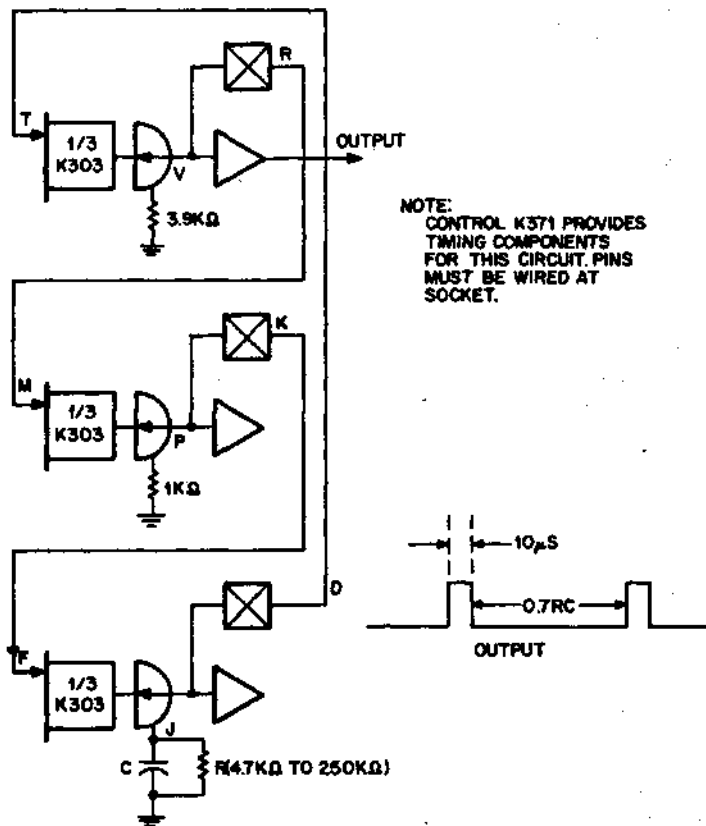

### 3/3 K303 AS CLOCK ABOVE 500 Hz

#### LONG DELAYS

Longer delays than 30 seconds using large electrolytic capacitors would suffer from increased drift due to capacitor leakage. Moreover, there are some applications in which moisture and contamination cannot reliably be excluded from the electronics environment, making 250K $\Omega$  timing resistance impractical due to leakage along board surfaces. For either situation, two techniques are available: either cascade several timer circuits, or combine a clock-connected K303 with one or more K210 counters. The clock may be gated off at an unused input to avoid synchronizing errors. The diagram below shows both techniques combined, using one K210 and all three sections of a K303 to obtain a 22-minute delay.

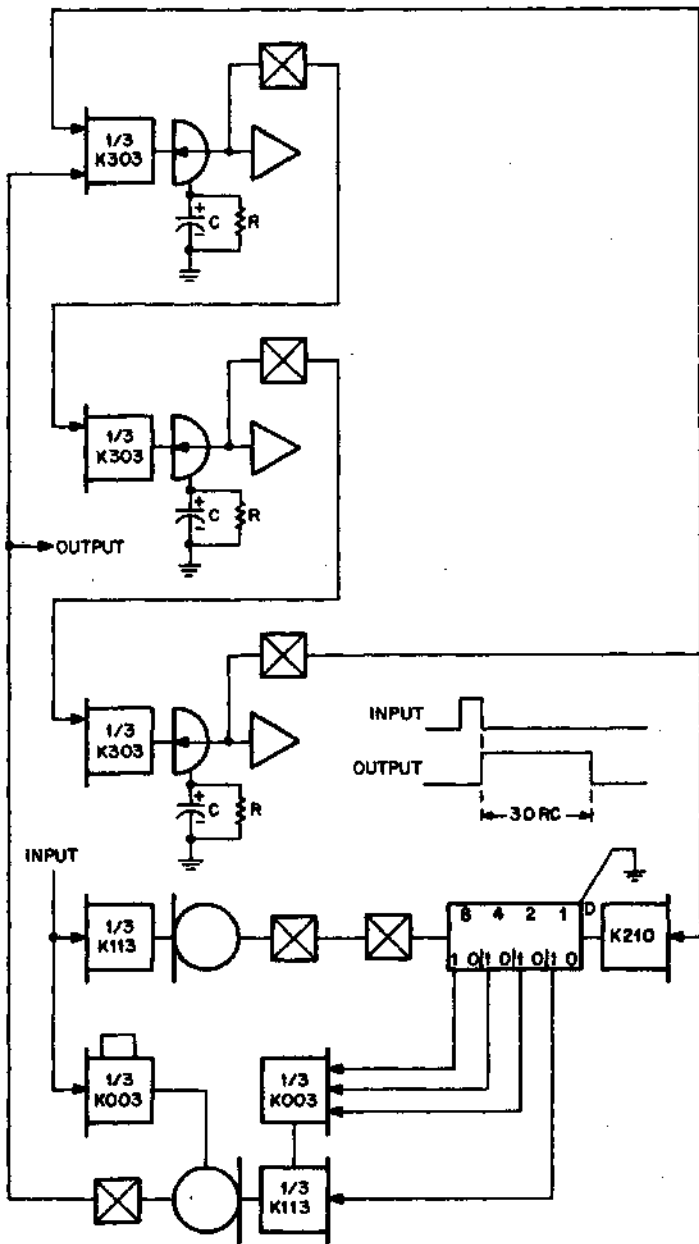

TIMER FOR UP TO 22 MINUTES



K303 WITH K373 AND K378

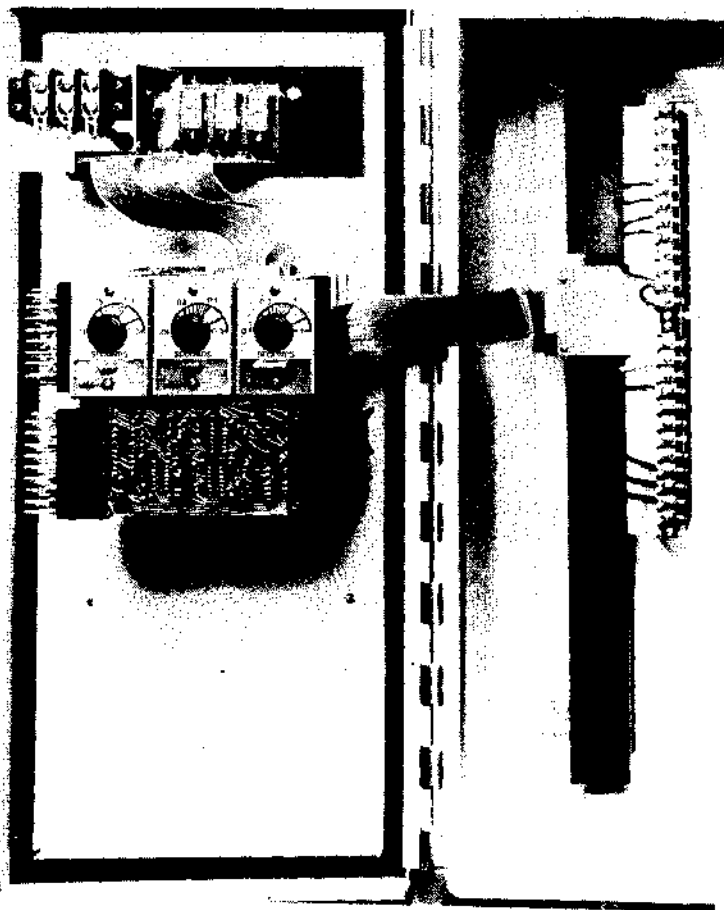

SMALL K-SERIES CONTROL INSTALLED IN NEMA 12 ENCLOSURE.

## MANUAL CONTROL MODULES

K410, K415, K420, K422, K424, K432

**K**  
**SERIES**

K-Series, in addition to providing a wide range of versatile logic and AC or DC interface modules, also contains in the K4XX module grouping a series of manual control modules. The modules may be used with or without the K950 modular panel hardware to enter data into or to display data from a logic control system.

The module types and general characteristics are listed in the following table.

Module	Use	No. of Circuits	Can Be Used Directly With M Series
K410	Indicator lights	5	Yes
K415	NIXIE display	1	Yes
K420	Toggle or push button switches	3	Yes
K422	Thumbwheel encoder	2	No
K424	Thumbwheel decoder	2	No
K432	Timer Controls	2-3	Yes

### USING THE K4XX MODULES

All of the K4XX modules are double height single thickness modules. The manual controls are mounted where the A connector pins are normally located and all pin connections are made on the B connector half of the module. The modules, however, are always inserted in the A socket locations (upper row) in the logic mounting panel.

A minimum of 3½ inches of space must be left directly above the logic socket mounting panel (K943, etc.) to allow enough room for the manual controls. A K950 modular hardware panel may be used to cover the 3½ inch space, if a neat, closed-front panel is desired for the controls.

Any module can be plugged into the socket adjacent to any K4XX module except in the following two cases:

1. No two K415 or K432 modules can be plugged into adjacent sockets.
2. The socket location directly to the left (facing the controls) of a K422 or K424 thumbwheel module may only be used for another K422 or K424 module.

The following pages explain the operation and characteristics of the individual module types.

# INDICATOR LIGHTS

K410

**K  
SERIES**

NEMA

MIL

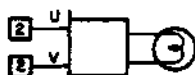
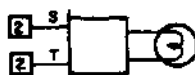
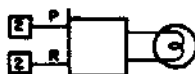
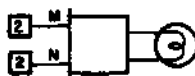

## DOUBLE HEIGHT

The K410 indicator lamp module provides a convenient way to build binary, decimal, octal, or bi-quinary displays. Lamps and lamp drivers receive their supply voltage through fast-on tab connectors. Any 12.6 V c. t. transformer may be used as a voltage supply provided the center tap is grounded.

The K410 may be used in a K943 mounting panel with or without the K950 panel hardware. Inputs are located on the B connector half of the module. Two modules plugged side by side on  $\frac{1}{2}$  inch centers provide 10 lamps for decimal, octal, or bi-quinary displays. More modules may be plugged in to provide five horizontal binary registers. Lamps turn on when both inputs are high or left unconnected.

Please see the write up on the previous page before using this module.

**K410—\$18**

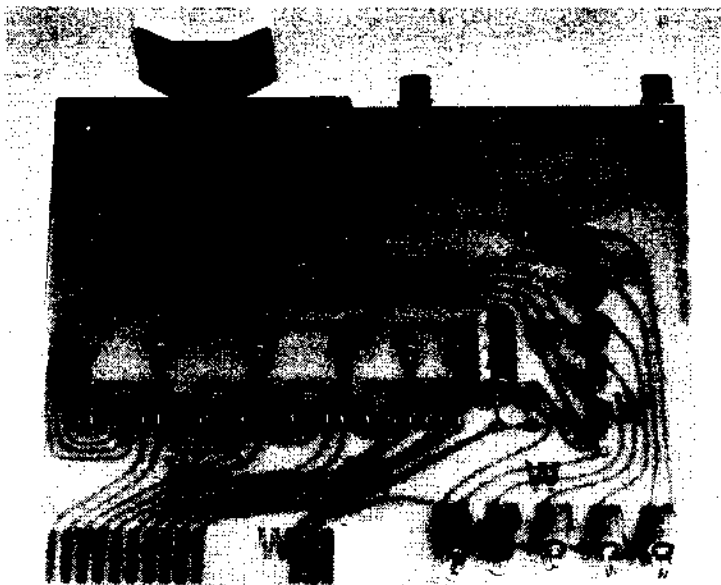

K410 INDICATOR

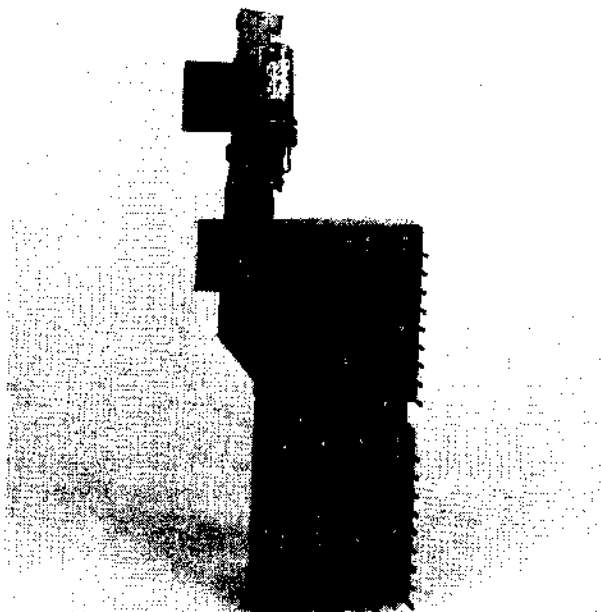

K415 NIXIE DISPLAY

**NIXIE DISPLAY**  
**K415**

**K**  
**SERIES**

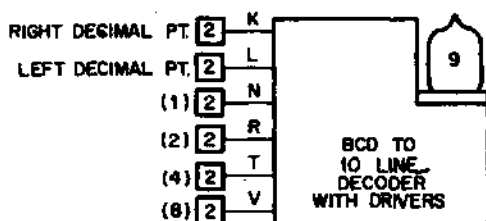

DOUBLE HEIGHT

The K415 NIXIE display module provides a convenient method of building decimal displays.

This unit is a double height module which may be used in a K943 mounting panel with or without the K950 panel hardware. All pin connections are made on the B connector half of the module. These boards may be plugged into every other connector socket allowing for neat multi-digit displays.

The NIXIE display tube mounted on the K415 is a side-viewing Burroughs type, B5750S, which has both right and left decimal points and numerals 0-9. The height of each character is 0.5 inches. The tube receives its supply voltage through fast-on tab connectors. Any 12.6v transformer may be used as a voltage supply.

**Caution:** If illegal numbers (11-15) are programmed into the K415, two numeral filaments will be lit simultaneously.

**K415—\$46**



# SWITCHES

## K420

# K SERIES

NEMA

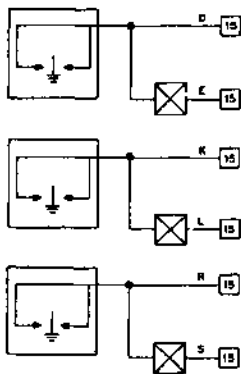

MIL

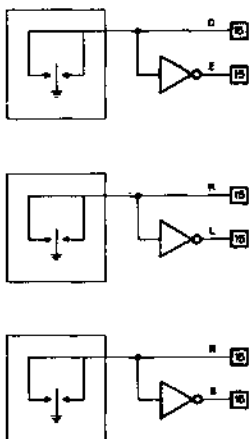

### DOUBLE HEIGHT

The K420 uses three 3-position Toggle switches. Only when the Toggle is in the center position will pins D, K, and R be high. The switch acts like a SPST Toggle in one direction and a spring returned push button in the other direction. Built in switch filters and Schmitt Triggers remove all switch contact bounce. Both inverted and uninverted outputs for each switch can drive 15 unit loads. Outputs are unslowed and may be used to drive M Series inputs directly.

The K420 may be used in a K943 mounting panel with or without the K950 modular panel hardware. All connections are made on the B connector half of the module.

Please see the write up preceding the K410 before using this module.



K420—\$33

# THUMBWHEEL ENCODER

K422

**K**  
**SERIES**

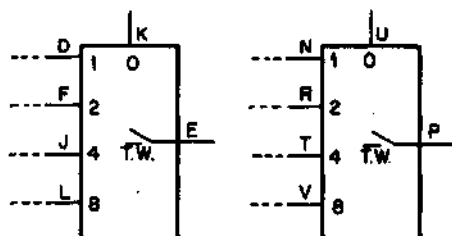

## DOUBLE HEIGHT

The K422 dual thumbwheel encoder used with the K134 inverter allows BCD data to be entered into the logic system from a K950 control panel.

K422 modules can be plugged in adjacent socket locations to build dual registers of up to 30 digits in width. Because of the width of the K422, the socket position directly to the left of the thumbwheel register may not be used for any module except a K422 or K424.

The four outputs D, F, J and L or N, R, T and V may be considered as AND expanders. These outputs should be connected to the four AND expansion nodes of a K134. Switch outputs have no noise filters and should never be used as a source of pulses.

Switches may be multiplexed by wiring the 1, 2, 4, and 8 outputs from the K422 to the K134 "AND" expansion nodes and connecting pins E and P to the outputs of separate gates. The desired thumbwheel is selected by causing a logic "0" at pin E or P. Logic "1" must be supplied to pins E and P of all the unselected switches. Groups of thumbwheels may be selected by connecting pins P and E to the same gate.

The K422 may be used in a K943 mounting panel with or without the K950 modular panel hardware. All connections are made on the B connector half of the module.

The K422 may be used directly with the K174 comparator without the K134 inverters. Connect the output pins D, F, J, L or N, R, T, V directly to the K174 pins M, P, S, and U. As before, since the K422 has no noise filters, the comparator output should only be a sensed logic level and not a source of pulses.

**K422—\$27**

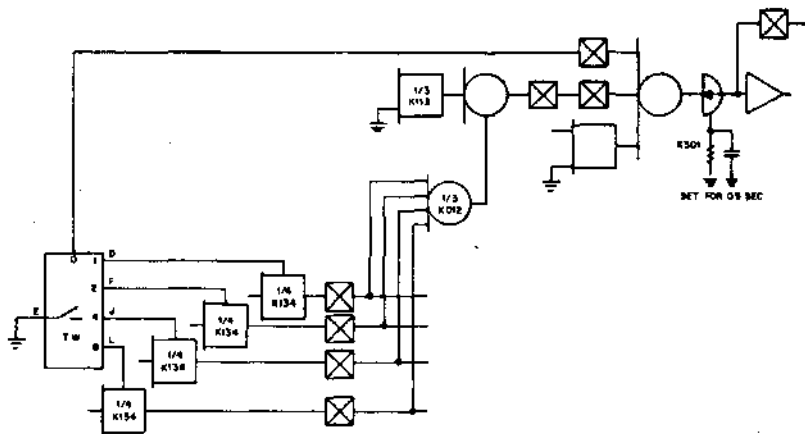

Pins U and K provide a convenient way to design an automatic defective switch detector. These pins have low outputs only when the thumbwheel switch is in the zero position. For all other switch positions U and K have high outputs. In the circuit above, the K301 "ON" delay should be set for about .5 seconds. If the thumbwheel switch does not make contact, the inverted timer output will go high after .5 seconds.

Please see the write-up preceding the K410 before using this module.

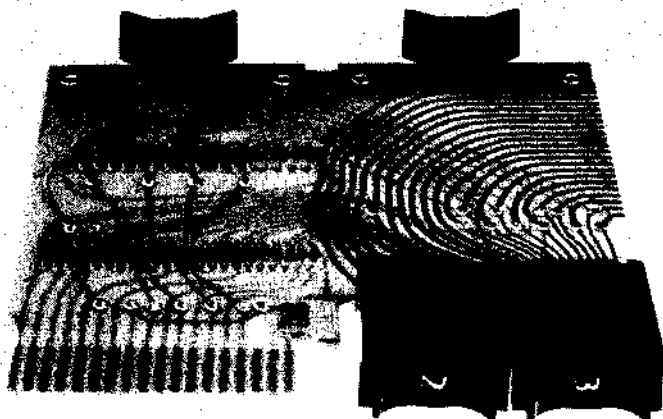

# THUMBWHEEL DECODER

K424

**K**  
SERIES

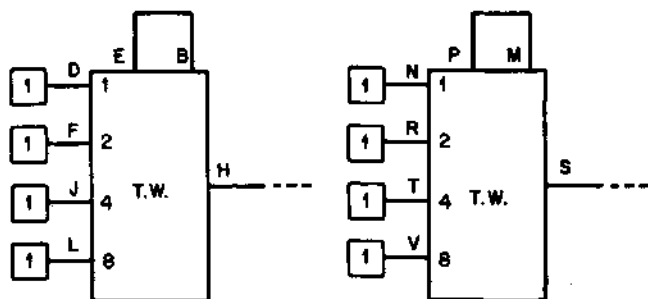

DOUBLE HEIGHT

The K424 thumbwheel decoder module is designed to be used with the K210 BCD up counter to allow the counter modulus to be selected manually from 1 through 10. For this application the decoder output is connected to pin J of the K210. The counter will reset to zero on the next high to low clock transition following the number that is manually selected.

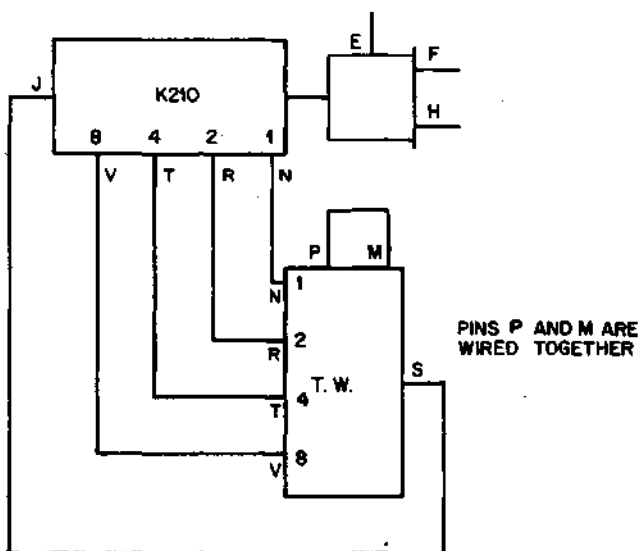

If the thumbwheel is set to the number 4, the counter will count 0, 1, 2, 3, 4, 0, 1, 2, etc.

K424—\$27

Pins E and P of the K424 are AND expander connection points. If pins E and B or P and M are jumpered, pins H and S may be connected to the OR expansion node of any K-Series module in the same fashion as the K003 AND/OR Expander.

Since the K424 is designed to be used only with up counters starting from a count of zero, the K422 must be used with the K174 comparator if specific numbers are to be decoded.

Up counters of more than one decade in length may also be manually controlled. The one-shot pulse width should be long enough to allow all carry pulses to propagate to the end of the counter. Pins B, E and P, M are not wired together for this application.

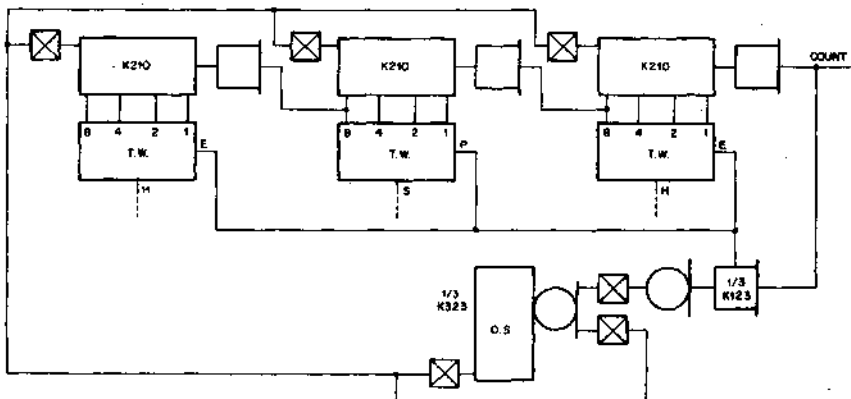

The K424 may be used with or without the K950 modular hardware panel. All pin connections are made on the B connector half of the module. Please see the write-up preceding the K410 before using this module.



# TIMER CONTROL

K432

**K  
SERIES**

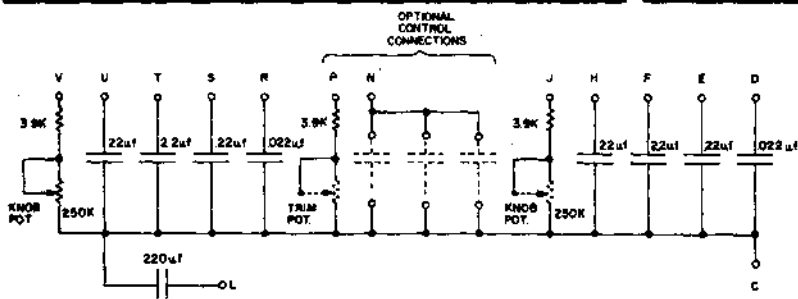

DOUBLE HEIGHT

The K432 Timer Control module used with a K301, K303, or K323 allows timer delays to be adjusted from a front panel by rotating a knob-pot. Timing ranges are selected by connecting the desired capacitor as shown in the table below either with wire wrap or 913 grip clip patch cords.

The board is predrilled and etched to provide space for a screw driver adjustable trimpot and capacitor to be mounted to obtain a third timer control. Each capacitor on the board may only be connected to one RC timer circuit at a time, however, any capacitor or resistor may be connected to form an RC.

The capacitor on pin L may be used with either the upper or lower knob-pot to obtain a range of 1 to 30 seconds.

Pins J, P, and V are connected to the RC time pins on the timer modules.

Connect to Pin J or V	RC Time Range	
	Min.	Max.
None	10 $\mu$ s	300 $\mu$ s
D or R	100 $\mu$ s	3 ms
E or S	1 ms	30 ms
F or T	10 ms	300 ms
H or U	100 ms	3 sec
L	1 sec	30 sec

Pin connections for selecting time ranges.

The K432 is designed to be used with or without the K950 modular hardware panel. All connections are on the B connector half of the module. Please see the write-up preceding the K410 before using this module.

K432—\$33

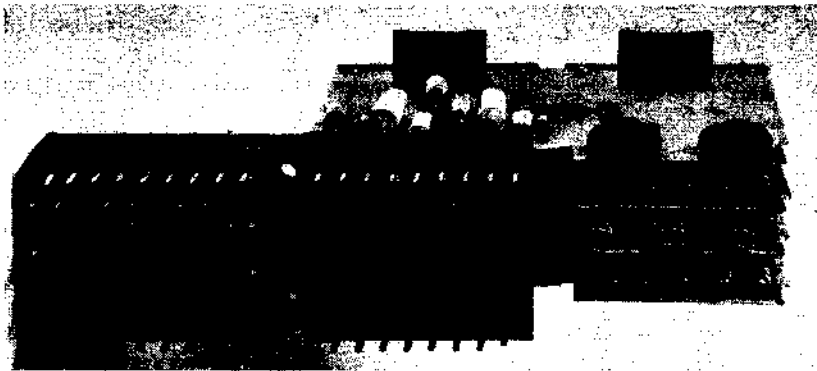
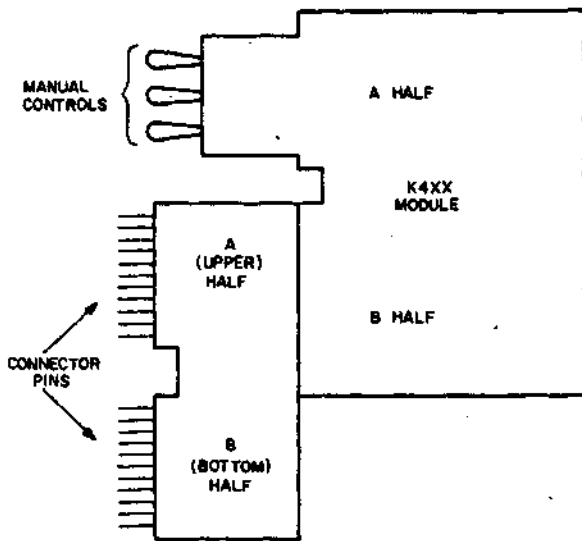

K432 CONTROL (top module) WITH K410 AND K420

## ACCESSORIES CONTAINING ELECTRONICS

On the following pages is a broad selection of interface modules. To help you get acquainted with the range of capabilities they offer, here is a summary table. Grouping by type of use to aid selection is not rigid. Maximum compatibility has been preserved to permit any combination of modules to be put together in the same system.

Logic-to-Interface Connection and Type of Use	Module Type	Compatible Accessories			
		K716 Interface Block	K724 Shell	K782 Thru Terminal	K784 Diode Terminal
Integral 30" Flat cable connector. For small controls with heavy-duty field wiring	120 VAC input: K508	X			
	120/240 VAC output: K604	X		X	
	Transducer input: K524	X		X	
	2.5 Ampere DC Driver: K644	X		X	
Integral Terminals for larger systems	120 VAC input: K578		X		
	120/240 VAC output: K614		X		
	1 AMP 55V DC DRIVER: K650		X		
	2.5 AMP 55V DC DRIVER: K652		X		
	250 Volt DC Driver: K656		X		
	4 Amp Driver: K658		X		
Solder Lugs with strain relief. For indicators, control panels, and nearby transducers	Transducer Input: K522			X	
	Dry circuit switch filter: K580			X	
	Inverted switch filter: K581				
	Low power indicator driver: K681			X	X
	Indicator/Relay driver: K683				X
Integral 12" flat cable with NIXIE® tubes	Decimal Display: K671				



# SCHMITT TRIGGERS

K501

**K  
SERIES**

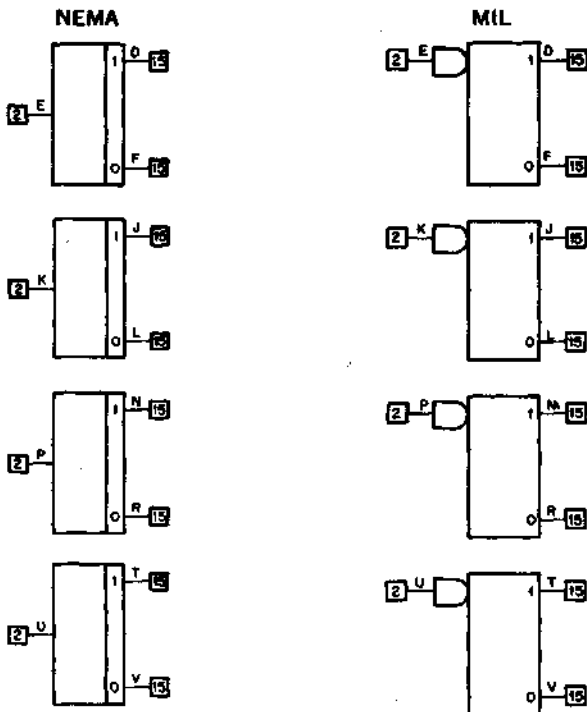

The K501 can be used with the K580, K581, or K578 to provide simultaneous true and complementary signals with full K series drive. Built in hysteresis and slowed outputs insure reliable operation in noisy signal environments.

Schmitt Triggers can also be used to speed up signals with very slow rise or fall times for input into pulse formers or logic circuits where timing considerations are critical.

The K501 is not designed to be connected directly to unfiltered contacts or other noisy signal sources. The Schmitt Triggers have standard K-Series outputs and their rise time is on the order of  $7\mu\text{s}$ . Minimum hysteresis between upper and lower Thresholds is 1 volt.

A logic "1" level at pins E, K, P and U forces pins D, J, N, and T high and pins F, L, R, and V low. A logic "0" level at pins E, K, P, and U forces pins D, J, N, and T low and pins F, L, R, and V high.

K501—\$25

# AC INPUT CONVERTER

K508

**K**  
SERIES

NEMA

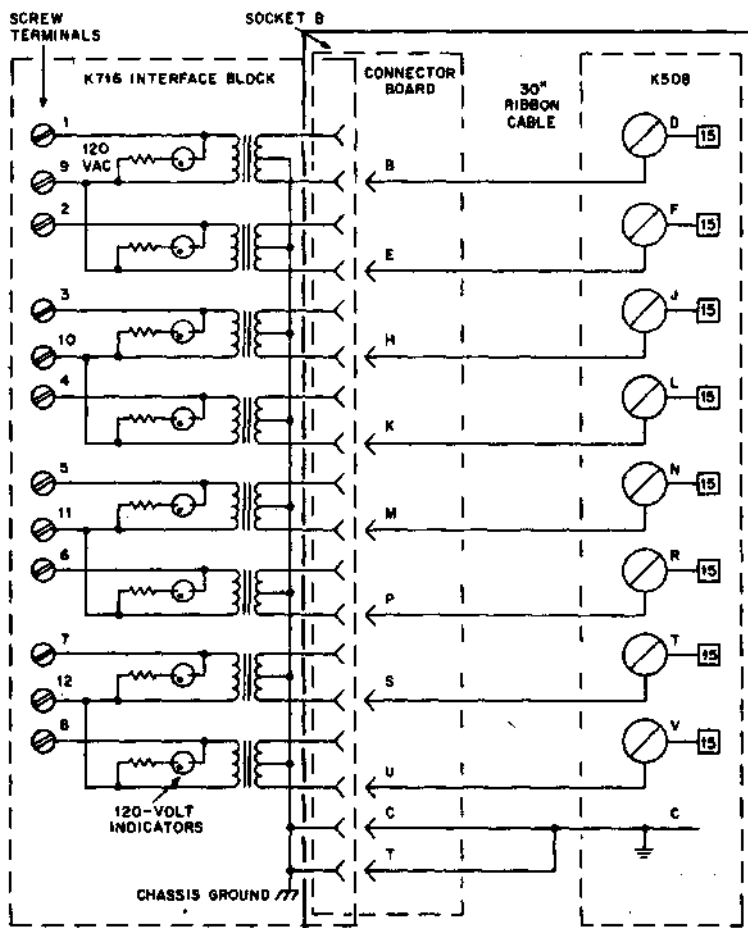

DOUBLE HEIGHT

K508—\$44

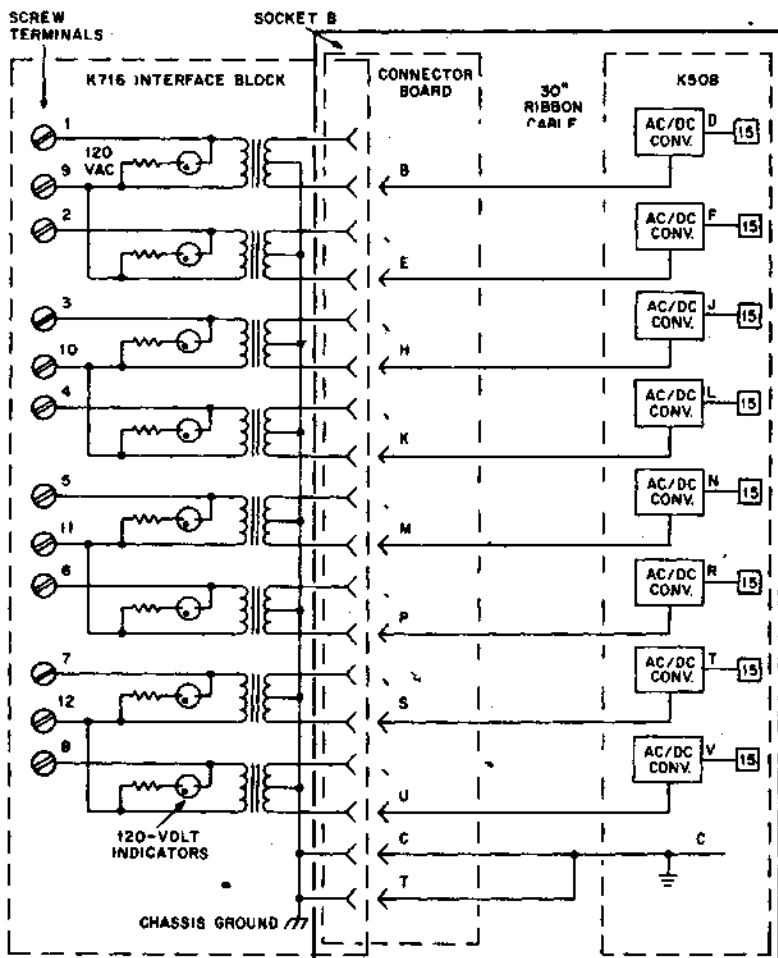

DOUBLE HEIGHT

The K508 AC input converter, operating through the K716 interface block, is designed for use with ordinary silver contacts in limit switches, pressure switches, pushbuttons and the like. Each input terminal presents a reactive load of 1 volt-ampere, which together with an external 120 volt AC pilot circuit voltage inhibits contamination buildup at the contact surface.

Electrical noise riding on pilot circuit wiring is attenuated in the input transformers and by hash filters at the K508 module. Contact bounce filtering is designed to respond to the first signal, and to leave the logic output in the "1" state in spite of skips lasting up to 100 milliseconds.

K508 output circuits have hysteresis, so that no intermediate output state can result from an ill-defined input condition. No separate Schmitt-triggers are required. Outputs are at ground for no input, at +5 volts when energized. All connections use upper connector.

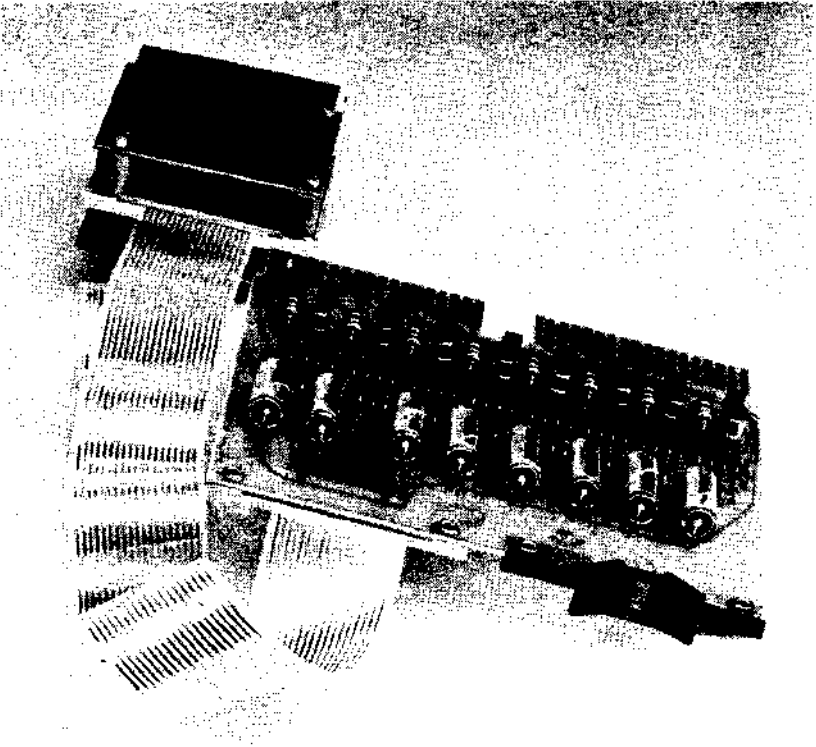

# SENSOR CONVERTER

K522

K  
SERIES

NEMA

MIL

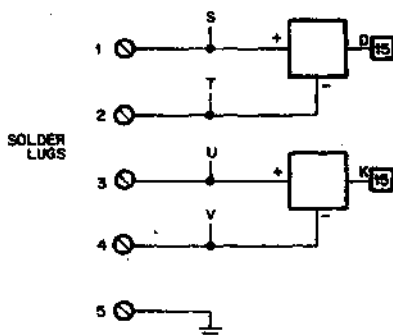
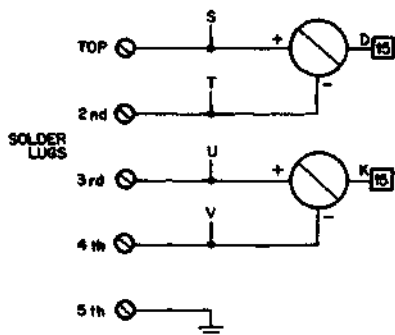

## K522 SENSOR CONVERTER

The K522 Sensor Converter is basically a voltage comparator that compares an unknown variable input voltage against a fixed internal threshold voltage (+1.8 v). This module can also be converted to a resistance sensing device by mounting a three prong trimpot in the predrilled holes provided in each circuit.

**Voltage Sensing**—This circuit has a built-in reference voltage of +1.8 volts, programmable hysteresis and noise cancelling ability. The K522 does not, however, provide the tolerance to high level noise or accidental application of line voltage which is obtainable from the K524.

If the unknown voltage applied to the K522, is higher than the reference voltage, the comparator output will be a logic 1. If this applied voltage, however, is less than the reference (+1.8 v) the output will be a logic 0.

The minus input to each converter is AC coupled to the internal +1.8 volt reference to provide common mode noise rejection (CMR). In order to be effective, it must be connected to the same ground point to which the Transducer is connected. Twisted pair wiring should be used between the Transducer and Converter to help insure that any noise pick up will be the same on both wires (this is common mode noise).

K522—\$25

CHARACTERISTICS	K522
Number of circuits	2
Module height and thickness	single
Input connections	solder lugs
Inputs accessible at module connector	yes
DC differential mode possible	no
Provision for adding transducer biasing trimpots in predrilled holes on board	yes
Noise cancellation range (common mode)	$\pm 1$ volt
Maximum + input range for correct output	0 to +5V
Tolerance to overvoltage (no damage)	$\pm 3$ volts
Minimum hysteresis	10mv
Maximum hysteresis	160mv
Minimum transducer resistance (at threshold)	400 $\Omega$
Maximum transducer resistance (at threshold)	20K $\Omega$
Noise Cancellation ratio at Line Frequency (CMR)	10:1
Noise Cancellation ratio at 1 KHz	20:1
Temperature Coefficient of Threshold (typical)	$\pm 1\text{mv}/^{\circ}\text{C}$ (0.1%)

**RESISTANCE SENSING** — With a trimpot mounted, the K522 becomes a resistance sensor. The circuit automatically provides a +3.6 volt bias to the trimpot. The resistance of the trimpot can be adjusted to equal the transducer resistance at the desired sensing point. Only when the resistance of the transducer is greater than the resistance of the trimpot will the sensor converter output go high.

In general, the K522 is suited to laboratory and light machinery use where transducers are nearby and there is little danger of high voltage being applied to them accidentally. This is especially important when low resistance transducers are used with board mounted trimpots, since the trimpot provides a path from the transducer leads back to the logic supply. (If high voltage such as 120 VAC were to get to the logic supply, all modules in the system would be destroyed.

The hysteresis of each K522 circuit can easily be selected in increments of 10 mv from a minimum of 10 mv (no connection) to a maximum of 160 mv by connecting one or more programming pins to the output.

Below is a table of pin connections for programming the hysteresis of each circuit.

Table of Hysteresis Programming Pins				
Value when wired to converter output	10mv	20mv	40mv	80mv
Circuit 1 (Pin D)	E	F	H	J
Circuit 2 (Pin K)	L	M	N	P

Example: To add 30 mv hysteresis to the basic 10 mv hysteresis for a total of 40 mv hysteresis, connect pins E and F or L and M to the circuit outputs.

See application notes for further information on the use of sensor converters.

**SENSOR CONVERTER**

K524

**K  
SERIES**

NEMA

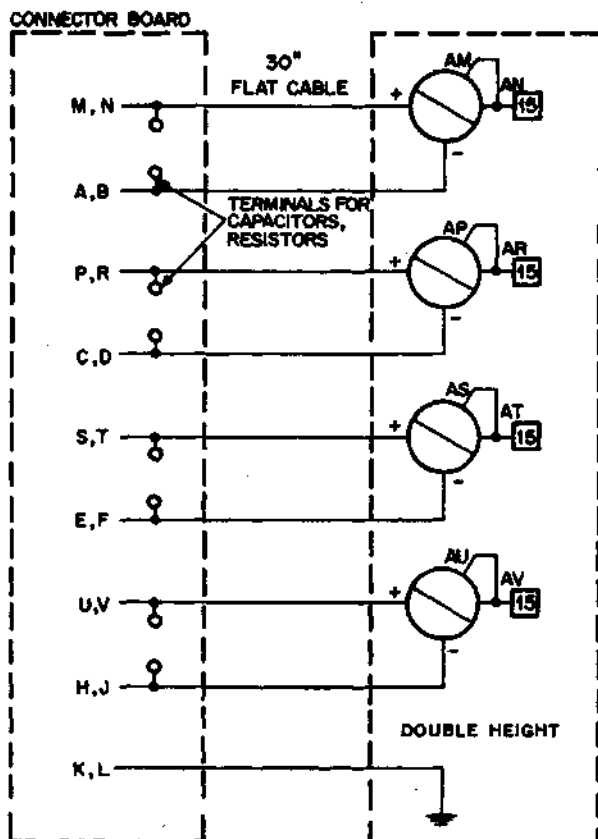

K524—\$98

## MIL

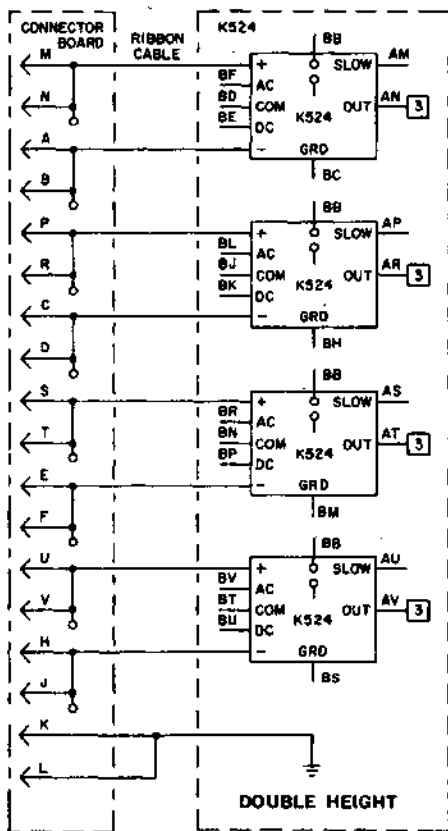
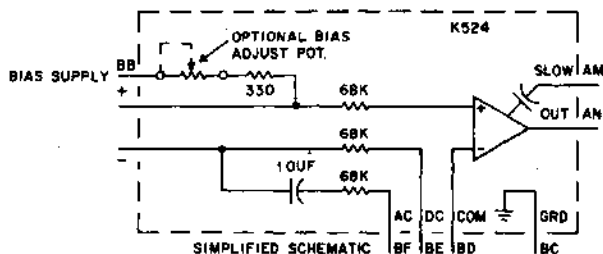

Basically a noise-rejecting, threshold sensing differential voltage amplifier, the K524 is readily adapted to sensing threshold points in DC analog signals, AC signals, and pulses. It can also be biased to sense resistance thresholds. The differential amplifying technique permits flexible grounding and shielding methods to accommodate floating signal generators and minimize noise.

**VOLTAGE SENSING**—The K524 provides a choice of either AC or DC coupling for voltage sensing.



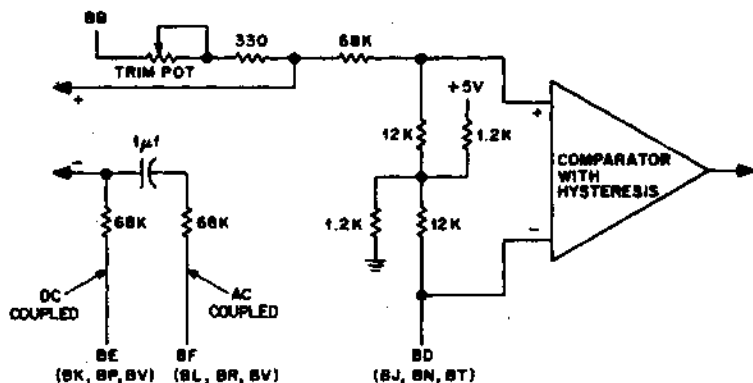

### K524 EQUIVALENT CIRCUIT

The following table shows the auxiliary pin connections on the lower module connector for the various applications of the K524.

APPLICATIONS	COUPLING	PIN CONNECTIONS
As low performance analog comparator, for comparing two photocells etc., or wherever reference is supplied externally.	DC	BD to BE, BJ to BK, BN to BP, BT to BU
Photocells, thermistors, pulse tachometers, pressure transducers or wherever it is convenient to use the internal 2.5 volt reference.	AC	BD to BF, BJ to BL, BN to BR, BT to BV

This module has an internal reference voltage of +2.5 volts. If the voltage swings of the unknown voltage applied to the K524 at its (+) input do not go above the internal reference supply voltage of the sensor, an external reference supply will be needed. This reference is applied to the (-) input. DC coupling should also be connected. If the unknown voltage does not go below the internal reference voltage, voltage divider techniques will have to be used.

Output transitions occur when input voltage differentials are within 0.3 volts or less of the reference supply. When the "+" input is more positive, the output is a ONE. When the "+" input is more negative than the reference, the output is a ZERO.

Signals up to 25 KHz, suitable for counting by K210, K211 or K220 counters, can be obtained with symmetrical input signals having at least 1 volt excursions past the switching point. Maximum output rates can be limited to approximately 5KHz by tying together pins AM and AN, AP and AR, etc.

**RESISTANCE SENSING** — The K524 may be used to sense resistance by mounting a trimpot in the predrilled mounting holes provided. When trimpots are used, pin BB must be connected to an independent  $\pm 5$  VDC bias supply, such as, a separate K731 operated from a separate transformer to insure against damaging currents through the bias circuits to the logic in case of accidental high voltages at K524 inputs. This precaution is most essential in systems containing K604 or K644 output converters, since inadvertent use of the wrong K716 socket is possible. This problem does not arise with self-generating sensors or where bias is supplied externally to variable-resistance sensors.

When the resistance of the transducer is greater than the resistance of the trimpot the output of the sensor converter will be high. The outputs of the sensor converters will go low when the transducer resistance drops below that of the trimpot.

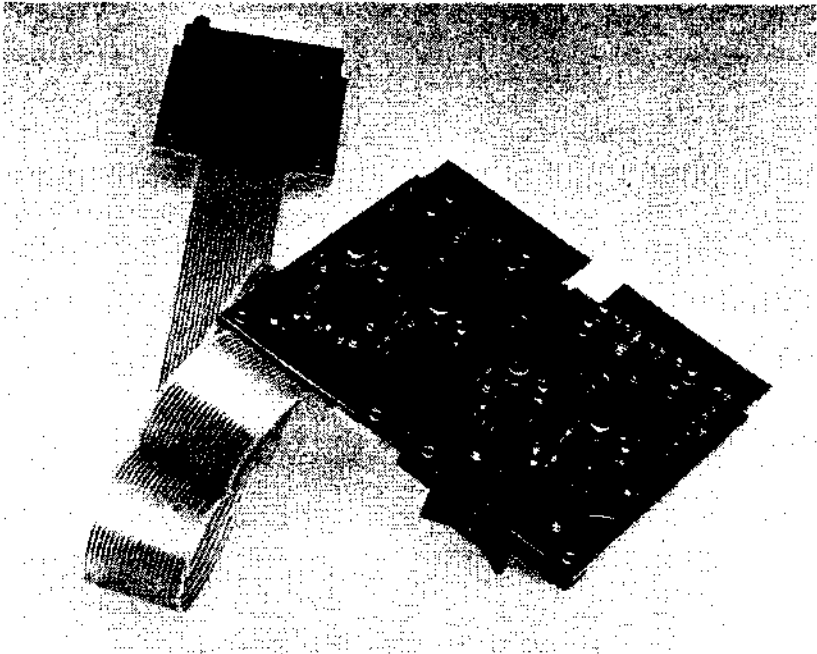

**K524 SENSOR CONVERTER**

CHARACTERISTICS	K524
Number of circuits	4
Module size	double
Input connections	cable connector
Inputs accessible at module connector	no
DC differential mode possible	yes
Provision for adding transducer biasing trim pots in predrilled holes on board	yes
Noise cancellation range (common mode)	$\pm 7.5$ volts
Maximum + input range for correct output	$\pm 30V$
Tolerance to overvoltage (no damage)	140 VAC
Hysteresis	10mv
Maximum switching rate	25KHz
Minimum transducer resistance (at threshold)	400 $\Omega$
Maximum transducer resistance (at threshold)	100K $\Omega$
Noise Cancellation ratio at Line Frequency (CMR)	10:1
Noise Cancellation ratio at 1 KHz	20:1
Temperature Coefficient of Threshold (typical)	$\pm 1mv/^{\circ}C$ (0.1%)

# QUADRATURE DECODER

K531

**K**  
**SERIES**

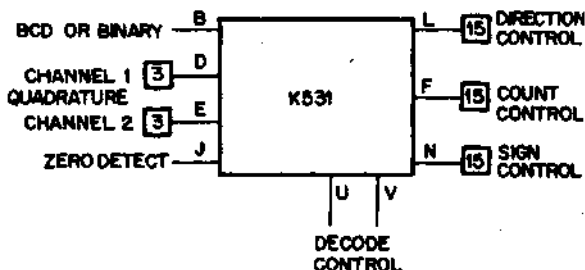

DOUBLE HEIGHT

The K531 is a quadrature decoder which can be used in conjunction with many types of dual channel rotary pulse generators (quadrature encoders) to measure the angular position of a rotating shaft.

This unit provides both direction and count controls for a K220 UP/DOWN counter register of up to 10 decades in length. Two or four counts per quadrature period can easily be selected and UP/DOWN counting can be done at frequencies up to 80KHz. Either BCD or 2's compliment binary counting can be selected. The K531 also contains the necessary logic for + and - sign control for BCD displays. Counting can pass through zero at the full 80KHz counting rate. Sign control can be suppressed if desired.

Quadrature inputs can be from any encoder whose logic "0" voltage is 0.5v or less and logic "1" voltage is between +2.4v and +15v DC. Each encoder output must be able to sink at least 3ma in the logic "0" state. These units are quite common and are available from companies such as Baldwin, Trump-Ross, and Data Technology.

Rotary pulse generators are rated for a specific number of pulses per revolution. For a dual channel generator, the quadrature output would be similar to the example below.

K531—\$70

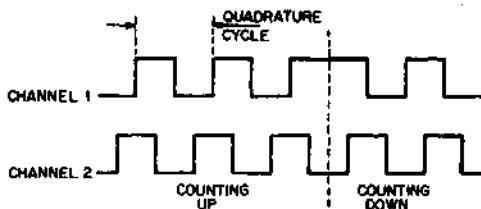

For counting up channel 2 leads channel 1 by 1/4 cycle and for counting down channel 1 lead channel 2 by 1/4 cycle. The channel which leads for UP and DOWN counting is determined by the type of quadrature encoder used and how it is wired to the K531. If the unit does not count properly, the quadrature inputs to the K531 may need to be switched.

To make the K531 compatible with the K220 UP/DOWN counter, a Direction Control output, Pin L, has been included. This output will provide a logic "1" level for up counting and a logic "0" level for down counting. Pin J, the Zero Detect input, is an "OR" expander pin. This expansion pin may be connected to K012 "OR" expansion gates (shown in the application section in the rear of this book) to complete the zero detect logic if a Sign Control output (Pin N) is desired for BCD nixie displays. One third of a K012 is required for each K220 module in the UP/DOWN register. The input at this pin determines the output on Pin N, Sign Control output.

Pin B must be grounded if sign control is desired for BCD counting. Sign Control is suppressed if pin B is left floating as shown in the table below for a 3 decade counter that is counting down from 999. For 2's compliment binary counting, Pin B must be left floating and the most significant bit in the K220 binary UP/DOWN register is used for the sign. The bit will be a "1" for minus and a "0" for plus.

	K220 BCD UP/DOWN Register Grounded	Pin B:	Open	Pin B: Open K220 Binary UP/DOWN Register Sign
+	999	+	999	0011 1110 0111
	•		•	•
	•		•	•
	•		•	•
+	003	+	003	0000 0000 0011
+	002	+	002	0000 0000 0010
+	001	+	001	0000 0000 0001
+	000	+	000	0000 0000 0000
-	001	+	999	1111 1111 1111
-	002	+	998	1111 1111 1110
	•		•	1111 1111 1101
	•		•	•
	•		•	•
-	999	+	000	1100 0001 1001

Pins U and V are connected to pin A to provide 2 or 4 counts per quadrature period.

Connect To pin A	Counts Per Period	Maximum Input Freq.	Maximum Output Count Frequency
None	4	20 KC	80 KC
U, V	2	40 KC	80 KC

The output on pin N denotes the sign of the number in the UP/DOWN register. It will be a logic "1" for a plus sign and a logic "0" for a minus sign. The number zero always causes a logic "1" at pin N so that a minus zero can not be displayed. The K671 NIXIE display can be used with a Burroughs B-5442 "±" Tube. Pins N and V on the K671 must be grounded and Pin N on the K531 must be connected to pin T on the K671.

See Application Notes for detailed information on using the K531 with NIXIE displays and computer interfacing.

# 120 VAC INPUT CONVERTER

K578

**K**  
**SERIES**

NEMA

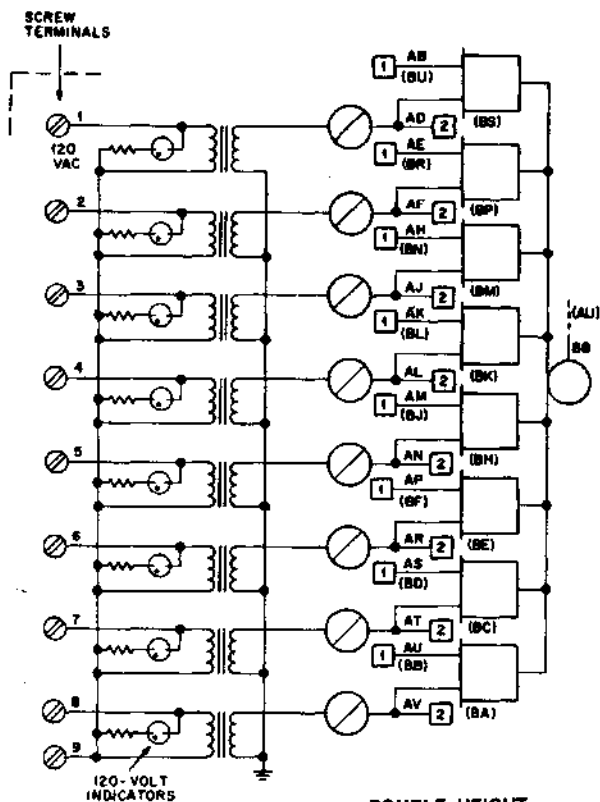

DOUBLE HEIGHT  
TRIPLE THICKNESS

NOTE:  
PINS IN ( ) ARE USED IF MODULE  
IS REVERSED IN SOCKET  
(GND=BT)  
(+5=BV)

K578 AC INPUT CONVERTER

K578—\$80

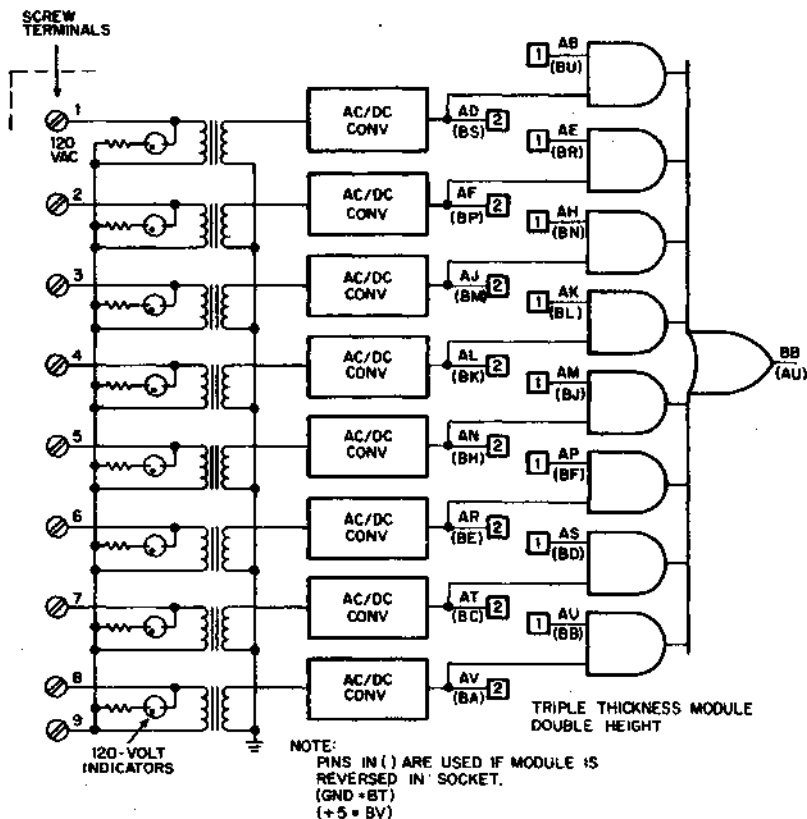

#### K578 AC INPUT CONVERTER

The K578 input converter, when mounted in a K724 interface shell, provides logic levels from 120 VAC signals from limit switches, relays etc. The 1 VA reactive load provided by the K578 isolation transformers insures sparking at pilot contacts. Together with the ample circuit voltage used, this reactive load assures maximum contact reliability.

Electrical noise riding on pilot circuit wiring is attenuated both by the input transformer and by RC filtering. Bounce filtering is designed to pick up by the end of the first full cycle of contact, and to drop out (return to "zero" output state) by the end of three full cycles after the input is removed. (About 50 milliseconds.) This speed of response is desirable in large sequential scanning-type control systems, even though occasionally a heavy contact may be observed to produce more than one output transition due to very long bounce duration. If necessary, response speed may be cut in half by tying 150 mfd from the offending logic output to ground. However, since no Schmitt triggers are included in the K578 (unlike the K508), a K184 or K501



must be used as described in the applications notes if it is important to know exactly how many contact closures have occurred in a given period.

Gating circuits equivalent to four K026 sections are included for contact scanning applications using the K161, or to facilitate forming the logical OR of many inputs. Direct outputs are from circuits similar to the K580, and may not be wired together.

Clamp-type terminals on the K578 take two wires up to size 14. Neon indicators are included. The K578 can also be used in the K943 mounting panel; however, some mechanical means of support must be provided to hold the K578 in its socket if vibration is a consideration.

The logic outputs of the K578 have low fanout capabilities and are therefore susceptible to noise pickup. Leads wired to the outputs of this module should be limited to six inches in length.

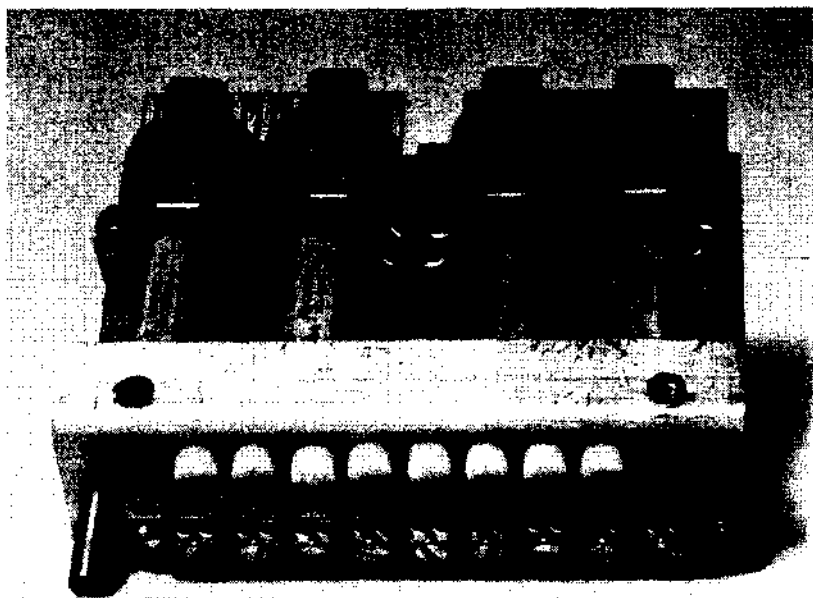

K578 TERMINAL STRIP CONNECTIONS FROM  
LEFT TO RIGHT ARE NUMBERS 1 TO 9

# DRY CONTACT FILTERS

K580, K581

**K**  
SERIES

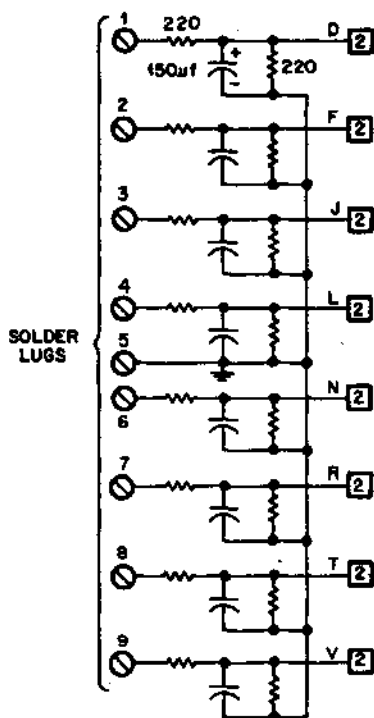

K580

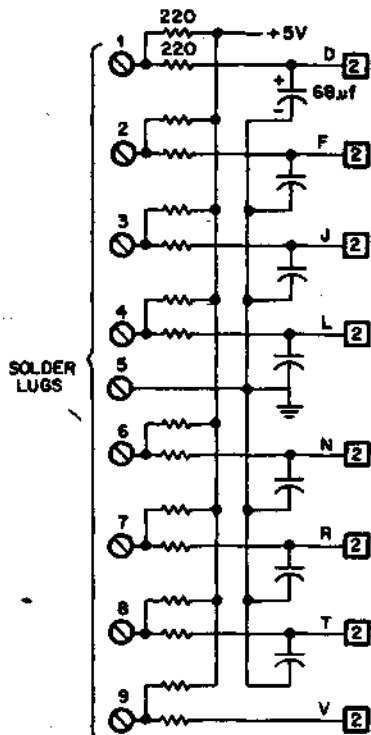

K581

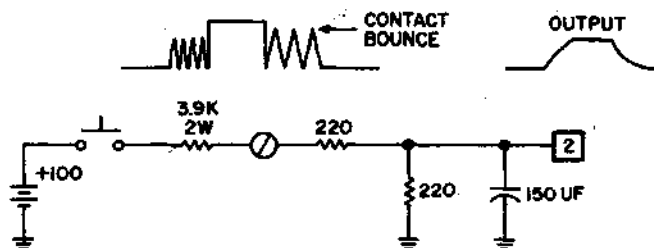

K580—\$28  
K581—\$20

These filters convert signals from dry or wiping contacts to logic levels. Primarily they are used with gold contacts such as the new encapsulated reed limit switches, thumbwheel switches, and the like. Those push-buttons or slide switches that provide good wiping action will also operate reliably with these filters, but silver contacts designed for long life on heavy duty loads are likely to give trouble. For them, use interfaces designed for such application like K508-K716 or K578, or at least switch a high voltage. (see K580 voltage table.)

Schmitt Triggers should be used on the outputs of both the K580 and K581 when they are used for one shot or timer inputs.

Access to K580 and K581 inputs is by solder lugs only. Strain relief holes are provided in the board (near handle) for a 9-wire cable. The avoidance of contact connectors on the logic wiring panel combined with heavy filtering guarantees noise isolation and protects modules by preventing accidental short circuits. Below is a summary of other characteristics.

	Contact Current	Contact Voltage	Output for Contact Closed	Time Delay on Closure	Time Delay on Opening
K580	22ma	See Table	high	10msec	30msec
K581	22ma	5V	low	20msec	20msec

(Time delay figures above are nominal, and assume connection to the Input of a standard gate such as K113 or K123.)

The contact current for the K581 comes from the logic supply, making it very important to assure freedom from accidental high voltages on K581 inputs which could damage many logic modules by getting through to the system power supply. This hazard is not present with the K580, which uses an external source of +10 volts or more. The table below shows how external dropping resistors may be added to provide higher voltage operation.

**TABLE OF K580 VOLTAGE DROPPING RESISTANCES**

CONTACT SUPPLY VOLTAGE	10	12	15	24	28	48	90	100	120
Dropping Resistance	0	82 $\Omega$	220 $\Omega$	620 $\Omega$	820 $\Omega$	1.8K $\Omega$	3.6K $\Omega$	3.9K $\Omega$	4.7 $\Omega$
Dissipation	—	0.05W	0.11W	0.3W	0.4W	0.85W	1.8W	2.0W	2.5W

When using dropping resistors and higher voltage supplies, total tolerance of resistors and supply should be  $\pm 10\%$  to insure high levels between +4 V and +6 V at the logic. Also observe that a handful of dropping resistors in 90 V or 120 V systems may dissipate more power than the entire logic system, and must be located so as not to cause excessive temperature rise in the K series environment.

Note that these circuits may not be paralleled to obtain the wired OR or wired AND function, and that fanout is limited to 2 milliampers in order to maintain the low (zero) output voltage within normal K-Series specifications. Fanout to ordinary logic gates and diode expanders may be raised to 4 milliampers if some noise and contact bounce rejection can be traded off; but hysteresis inputs such as those at counter inputs, rate multiplier, etc., may not switch properly if the logic zero is allowed to rise much above  $+0.5$  V.

Looking at the component side of both the K580 and K581, the solder lug connections are numbered 1 to 9 from pin end to handle end.

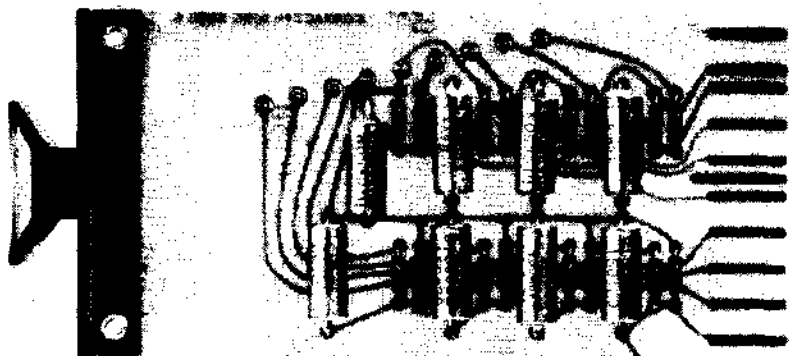

K580

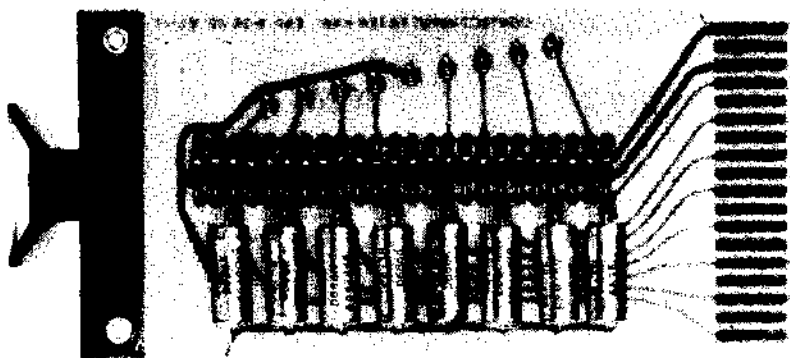

K581

# EIA INPUT CONVERTER

K596

**K  
SERIES**

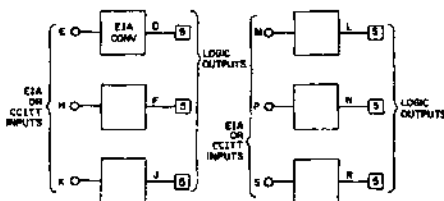

Any bipolar input signals with amplitudes between  $\pm 3$  volts and  $\pm 25$  volts will be transformed by this non-inverting converter into standard K-Series or M-Series logic signals with driving capabilities of 5 ma or 3 unit loads, respectively. Load for paralleling (wired OR): 1 milliampere. Input impedance stays between  $3K\Omega$  and  $6K\Omega$  for full capability with both the American EIA and the European CCITT standards for data transmission. Built-in noise filtering causes transition delays of several microseconds, limiting the maximum baud rate that can be handled.

Open-circuit inputs will produce low (zero-volts) outputs on the lower three circuits. The output stage of the first three circuits if inputs are open is controlled by pin B, which must be grounded for outputs low or connected to pin A (+5 volts) for outputs high. This last provision allows type 33 or type 35 current switching teletypes to be converted and wire ORed with modern interfaces. Pin B must be connected either to pin A or pin C: if it is left open, there may be crosstalk between circuits.

Input	Pin B Connection	PINS D, F, J	Pins L, N, R
Open	C	0	0
Circuit	A	+5	0
+3 to +25V	A or C	+5	+5
-3 to -25V	A or C	0	0
0V	A or C	0	0

Please observe that noise and interference can enter a digital system through any wires that pass through a noise field. K596 modules should be located at the edge of the system, and communication wiring should not be allowed to lie close to logic wiring by more than a few inches.

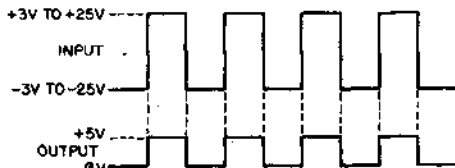

K596—\$20

# ISOLATED AC SWITCH

K604

**K**  
SERIES

NEMA

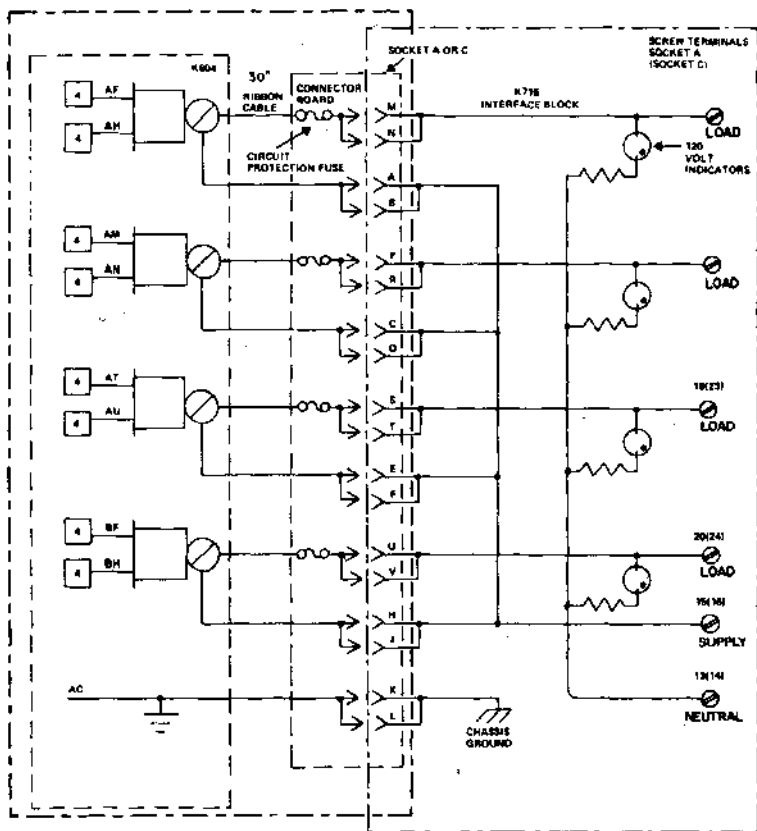

DOUBLE HEIGHT

K604—\$110

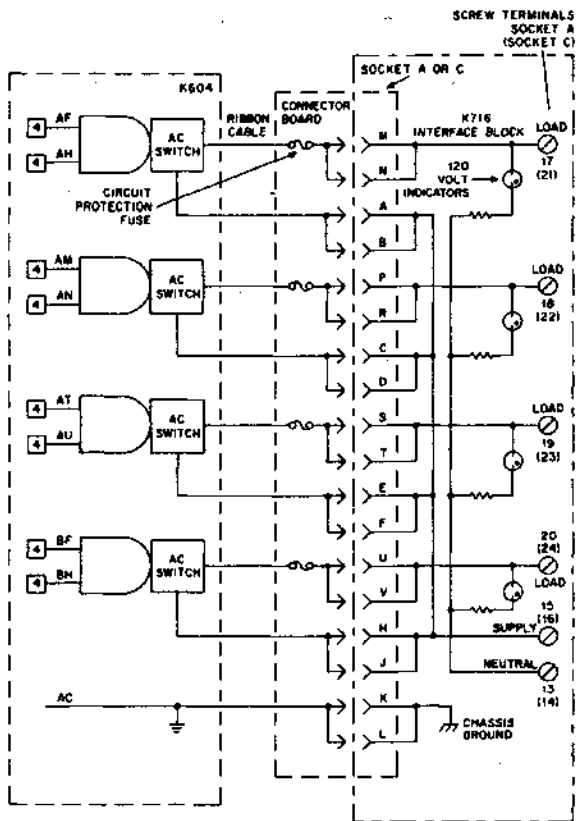

## DOUBLE HEIGHT

Operating in conjunction with the K782 or K716 Interface Block, the K604 permits AC operated valves, solenoids, small motors, motor starters and the like to be controlled directly from K Series logic. Each circuit can handle up to 250 volt-amperes continuously. Total for any module, however, should not exceed 500 volt-amperes averaged over one minute. Ratings below include maximum horsepower based on use of Allen-Bradley type K motor starters. Less sensitive starters or relays may have significantly reduced capacity.

Maximum Capacity, each K604 circuit (120 v AC lines)

Condition	Continuous V.A.	Inrush V.A.	Motor Direct	Type K Starter	208/220 Max. H.P.	480/600 Max. H.P.
With Fuse	250	600	1/20 H.P.	Size 3	30	50
No Fuse	250	1800	1/10 H.P.	Size 4	50	100

Littlefuse® type 275005 5 amp fuses provide fault protection for the triac output circuits. The fuses are mounted by clips on the connector board for easy replacement. Without the fuses, short circuits will destroy the module. The no-fuse information above is for reference only, and operation without fuse protection cannot be recommended. Circuits cannot be paralleled to increase ratings.

AC switch turnon takes place within 500 microseconds after input logic gate goes high. Turnoff takes place at zero crossings of the current. Maximum "off" leakage: 10 ma RMS at 140 VAC. Line voltage rating: 100 to 140 VAC, 50 to 60 Hz. Each triac output circuit has 400-volt breakdown rating. Shunt capacitor and shunt clipping devices inhibit false triggering on line transients.

Where very small devices such as pilot lamps, light duty relays, or AC input converters constitute the sole load, an auxiliary load such as a 12K $\Omega$  2 watt resistor may be required to absorb sufficient holding current for full voltage output.

Two special precautions are made necessary by the presence of AC line voltages on the K604 module. First, always disconnect the ribbon cable connector before inserting or removing a K604 or an adjacent module, to avoid shocks or component damage. Second, W993 copper-clad boards (\$4 each) should be installed between K604 modules and all other types except K508 or K644. With the pin A connection cut away, on either the board or the socket, the W993 copper clad board acts as an electrostatic shield. If this added interface protection is later found to be unnecessary, the sockets reserved for shield boards can be used to add logic features, modifications, etc. Refer to Construction Recommendations.

If desired, a K782 terminal board instead of the K716 may be used to obtain connections to field wiring. No indicators are provided by the K782, however.

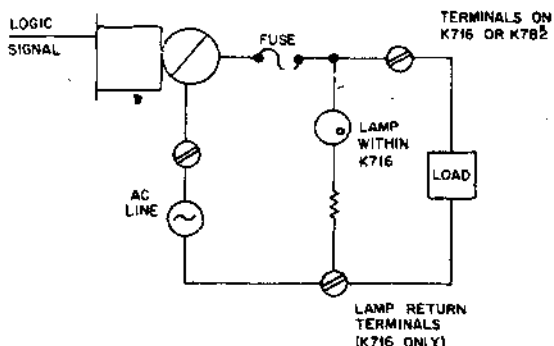

K604 CIRCUIT IN USE



# ISOLATED AC SWITCH

K614

**K**  
SERIES

NEMA

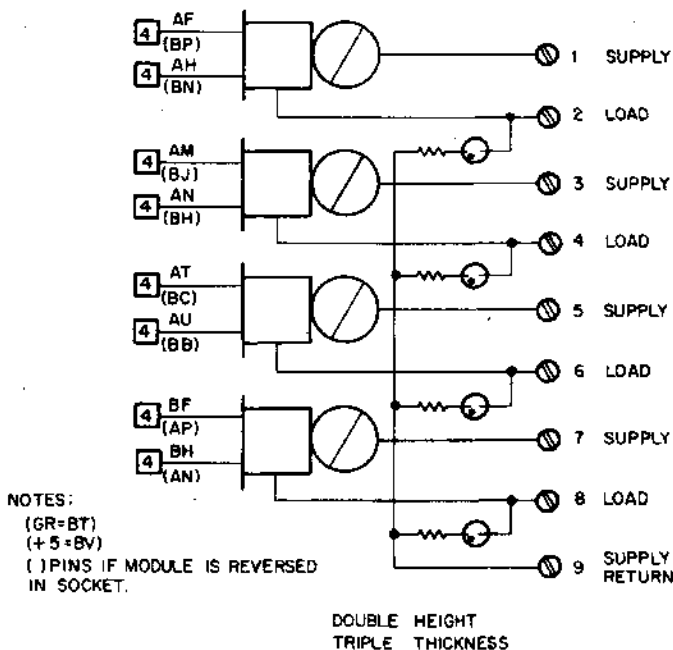

## K614 AC SWITCH

This module uses the K604 circuit and behaves in most respects the same. However, the K614 is designed to fit a K724 interface shell. Accordingly the K614 has built-in clamp-type terminals for wires to size 14, interchangeable indicators, and output ratings boosted to 500 VA per circuit by the larger heat sink area available in this configuration.

Littlefuzer<sup>®</sup> type 275005 fuses provide fault protection for the triac output circuits. The fuses are mounted by clips on the connector board for easy replacement. Without the fuses, short circuits will destroy the module.

Circuits cannot be paralleled to increase ratings.

K614—\$88

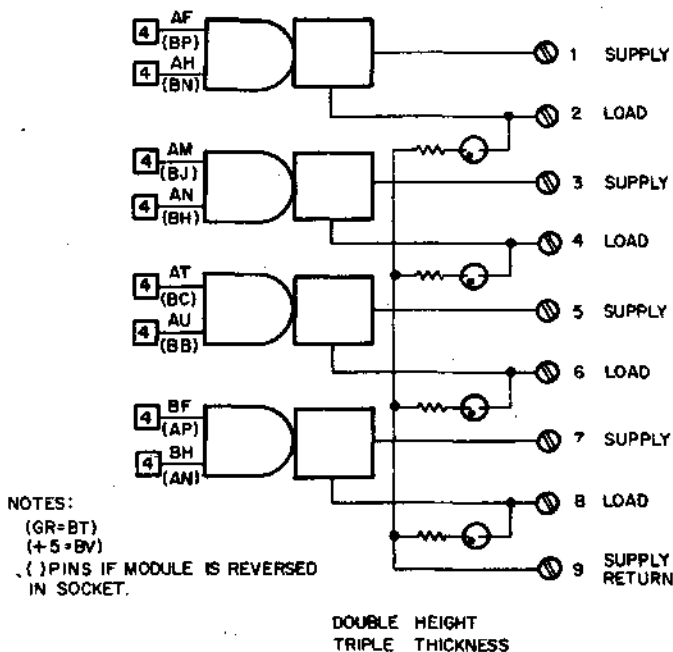

## K614 AC SWITCH

The output rating of each K614 circuit is 500 VA due to the large heat sink area available, however, the maximum output rating per module should not exceed 750 VA over a 1 minute period. Shunt capacitors and shunt devices inhibit false triggering on line transients.

Two special precautions should be taken when using a K614 module. First, if the inputs are not grounded, the triac outputs will turn on. The user should be particularly careful when removing modules from a circuit which provide the low "0" logic levels to the K614. Remember, all K-Series inputs normally assume a high level when no input is connected. Second, W993 copper-clad board (\$4.00 each) should be installed between K614 and all other types except K508 or K644. With the pin A connection cut away, on either the board or the socket, the W933 copper-clad board acts as an electrostatic shield. If this added interface protection is later found to be unnecessary, the sockets reserved for shield boards can be used to add logic features, modifications, etc. Refer to Construction Recommendations.

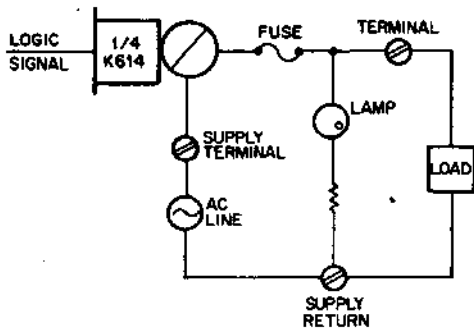

K614 CIRCUIT IN USE

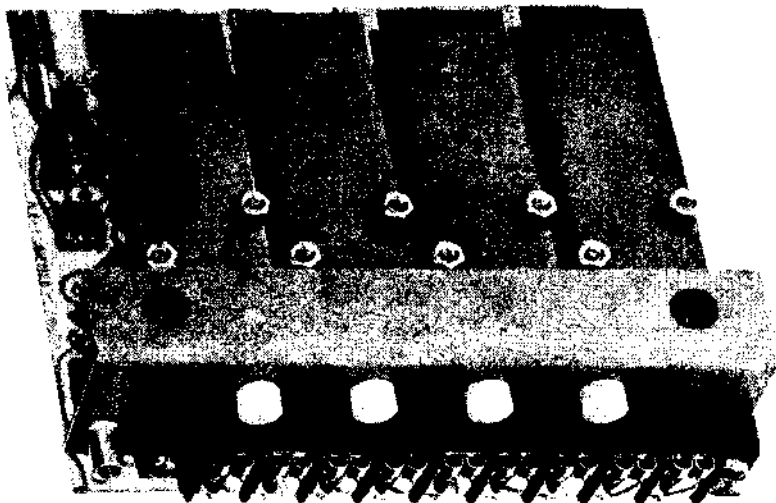

K614 TERMINALS AS VIEWED LEFT TO RIGHT ARE NUMBERED  
1 THROUGH 9

# ISOLATED AC SWITCH

K615

**K**  
SERIES

NEMA

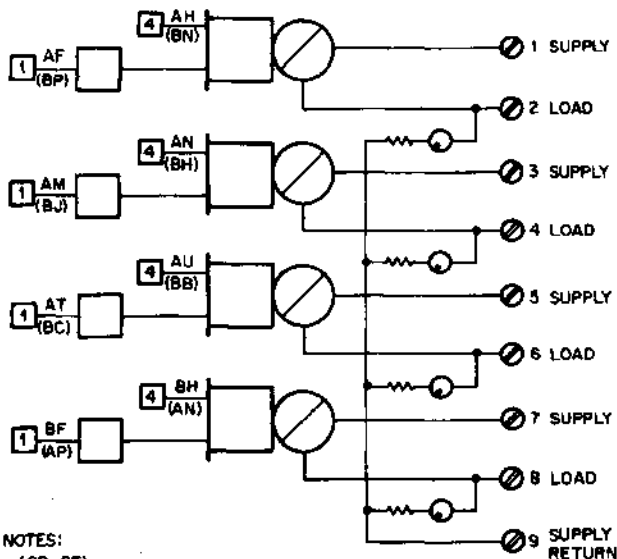

**NOTES:**

(GR-BT)  
(+5-BV)  
( ) PINS IF MODULE  
IS REVERSED IN  
SOCKET.

DOUBLE HEIGHT  
TRIPLE THICKNESS

## K615 AC SWITCH

The K615 was designed to fit a K724 interface shell. This module uses the same switching circuits as the K614. The difference between the K614 and K615 is in the input circuits; one input on each circuit of the K615 (AF, AM, AT, and BF) normally assumes the logic "0" level when it is open circuited. This is contradictory to all other K-Series inputs which normally assume a high level when no input is connected. Because the switch turns on when both inputs are high, this feature provides an additional fail-safe against the accidental removal of modules or cut wires that connect directly to the AC switch input. If the protected input is unused it must be wired to pin A.

K615—\$92

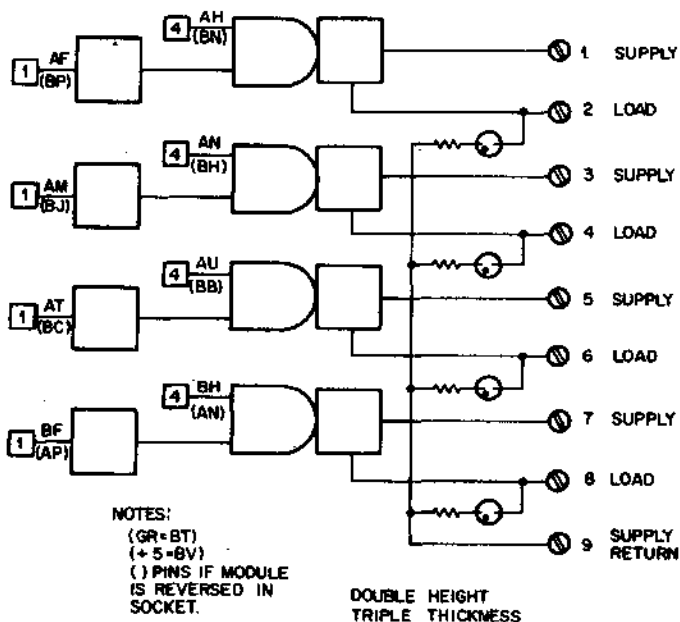

## K615 AC SWITCH

The K615 has built-in clamp-type terminals for wires to size I4, interchangeable indicators, and output ratings of 500 VA per circuit due to the large heat sink area available in this configuration.

Littelfuze® type 275005 fuses are mounted by clips on the connector board for easy replacement. Without the fuses, short circuits will destroy the module. Circuits cannot be paralleled to increase ratings.

The output rating of each K615 circuit is 500 VA, however, the maximum output rating per module should not exceed 750 VA over a 1 minute period. Shunt capacitors and shunt devices inhibit false triggering on line transients.

W993 copper-clad boards (\$4 each) should be installed between K615 modules and all other types except K508 or K644. With the pin A connection cut away, on either the board or the socket, the W993 copper clad board acts as an electrostatic shield. If this added interface protection is later found to be unnecessary, the sockets reserved for shield boards can be used to add logic features, modifications, etc. Refer to Construction Recommendations.

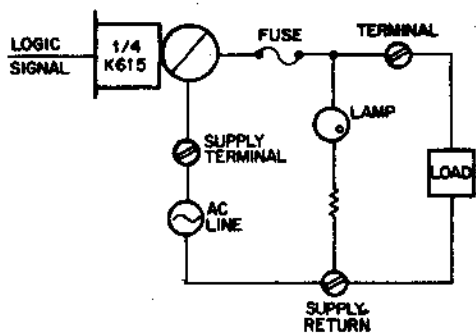

K615 CIRCUIT IN USE

## DC DRIVER

K644

K  
SERIES

NEMA

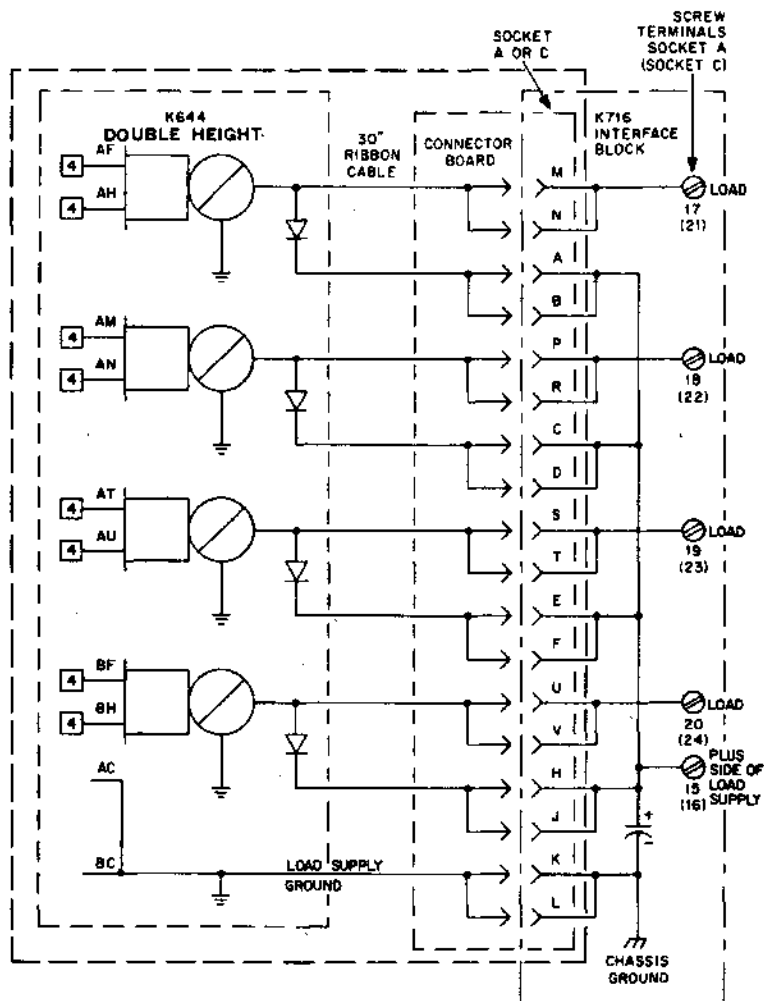

K644—\$66

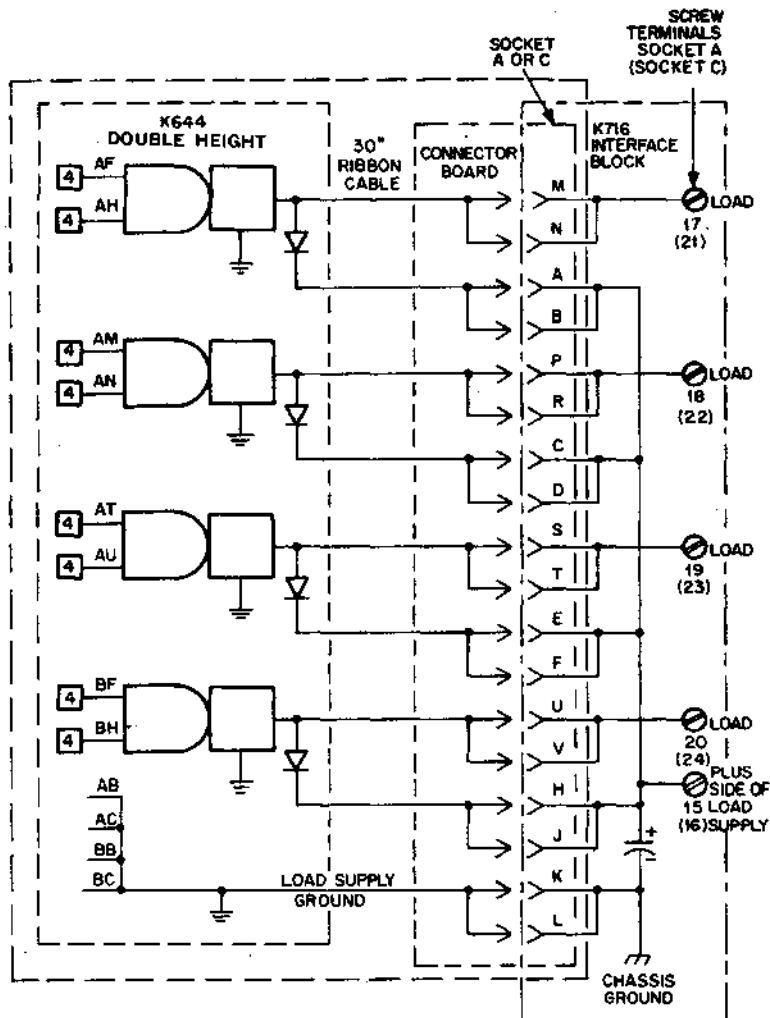

Operating through the K782 or K716 Interface Block, the K644 DC Driver permits stepping motors, dc solenoids, and similar devices rated up to 2.5 amperes at 48 volts to be driven directly from K series logic. Built-in clamping diodes protect switching transistors from transient over-voltage.

Total output circuit current for the K644 module must not exceed 4 amperes averaged over any 1 minute period. The ribbon connector should be unplugged before inserting or removing a K644 module.

Moving the parts of a magnetic device change the winding inductance. To equalize magnetic field turnoff and turnon times, the ratio of inductance to



total circuit resistance must be held constant. This demands more resistance in the circuit during turnoff, when the inductance is higher. Resistance may be inserted between K716 terminal 15 (or 16) and the load supply to achieve this, provided the K644 output voltage will not exceed 55 volts. Whether resistance is added or not, these clamp return terminals must be connected to the plus side of the load supply to protect the module from overvoltage during turnoff.

The K644 may be used with a K782 instead of a K716 to obtain the screw terminals needed for connecting heavy duty field wiring.

See applications section for further information concerning the use of DC drivers.

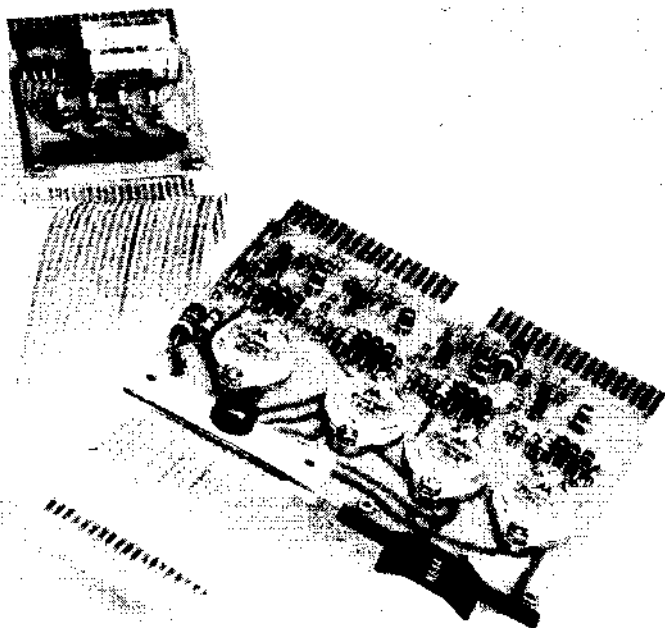

# DC DRIVER

## K650

# K SERIES

NEMA

MIL

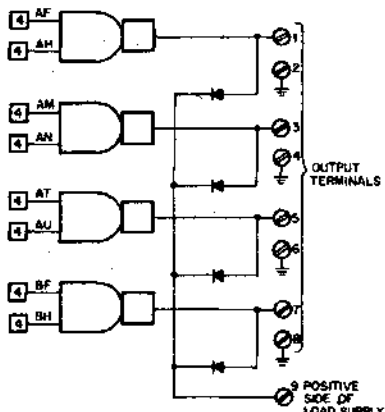
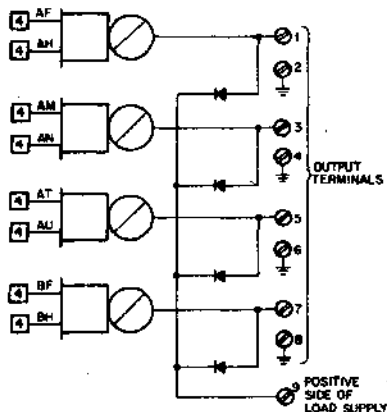

**DOUBLE HEIGHT  
TRIPLE THICKNESS**

### K650 DC DRIVER

The K650 DC driver can deliver up to 1 ampere at up to 55 VDC. These four-1 circuit modules drive external loads through built-in clamp-type terminals. They can be mounted in the K724 interface shell, but do not have neon indicator lamps across their outputs terminals as the other shell mounting modules.

The positive side of the load supply should be connected to protect output transistors from damage due to turn-off transients. See the application section for further DC driver information.

K650—\$40

Module	Output Ratings		
	Resistance	Inductive	INCANDESCENT LAMPS
K650	55V  1 AMP	55V 1 AMP With added suppression diodes	Lamps rated 60ma; to 48V
			Lamps rated 120ma to 28v
			Lamps rated 250ma to 18V
			Lamps rated 400ma to 12V

Note greatly reduced ratings on tungsten loads. Lamp filaments draw typically ten times more current at turnon than when hot, resulting in very high transistor dissipation if supply voltage is high. Series current limiting resistors or shunt preheat resistors could be used to limit surge in certain cases, but ratings above assume this would be awkward or impractical.

Terminals 2, 4, 6 and 8 must be connected directly to the negative terminal of the load power supply or damage to the module will result from high currents.

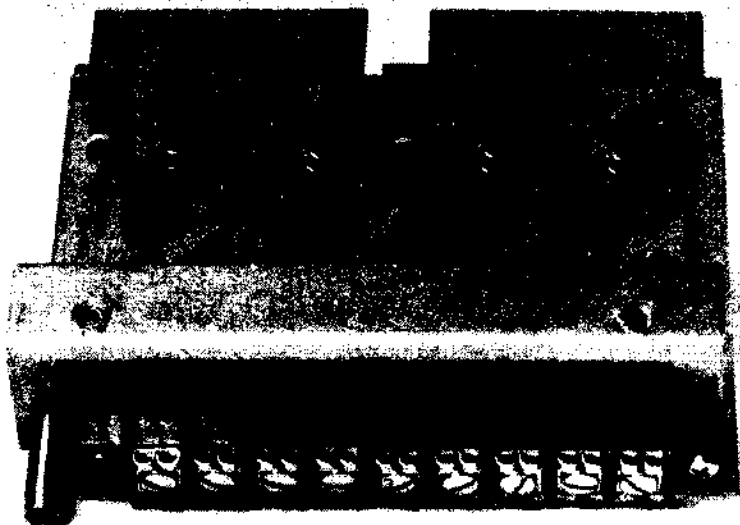

# DC DRIVER

## K652

# K

## SERIES

NEMA

MIL

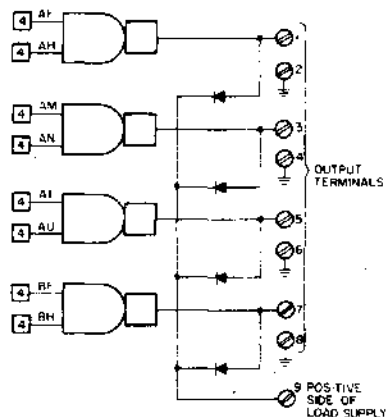
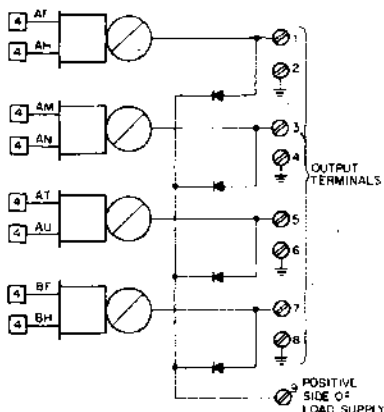

DOUBLE HEIGHT  
TRIPLE THICKNESS

### K652 DC DRIVER

The K652 DC driver has four circuits each of which can deliver up to 2.5 amperes at up to 55 volts. Like the K578, K614, K656 and other modules, this unit has built-in clamp-type terminals for wires up to size 14. It can be mounted in the K724 interface shell, but does not have neon indicators across the output terminals as other shell mounted modules.

The positive side of the load supply should be connected to protect output transistors from damage due to turn-off transients. See the application section for further DC driver information.

Terminals 2, 4, 6 and 8 must be connected directly to the negative terminal of the load power supply or damage to the module will result from high currents.

K652—\$50

**DC DRIVER**  
**K656**

**K**  
**SERIES**

NEMA

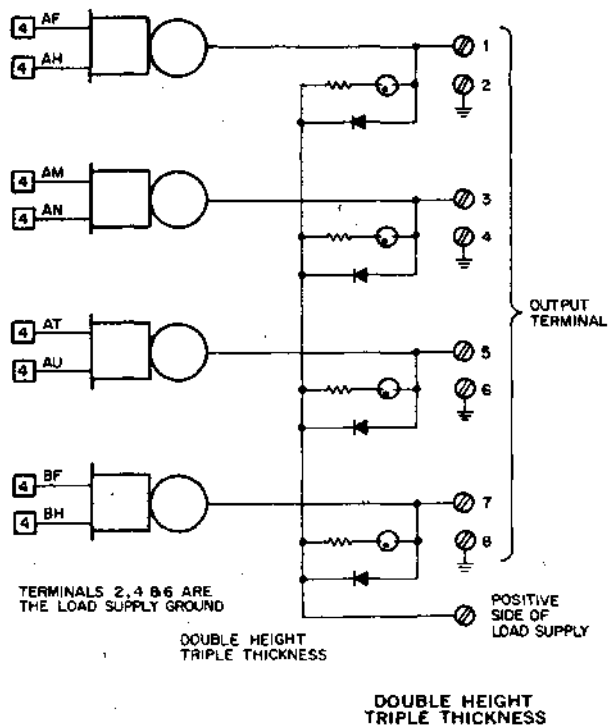

**K656 250 VOLT DRIVER**

Each circuit of this versatile driver can deliver up to 1 ampere at up to 250 volts, making it ideal for driving heavy-duty brakes and clutches or for high speed operation of other inductive loads. Like the K578 and K614, this module has integral clamp-type terminals and neon indicator lamps. (Lamps are effective only at 90 volts and above.) This driver module is designed to be used with K724 interface shells. Positive side of load supply must be connected to protect output transistors from damage during turnoff transient.

**K656—\$80**

MIL

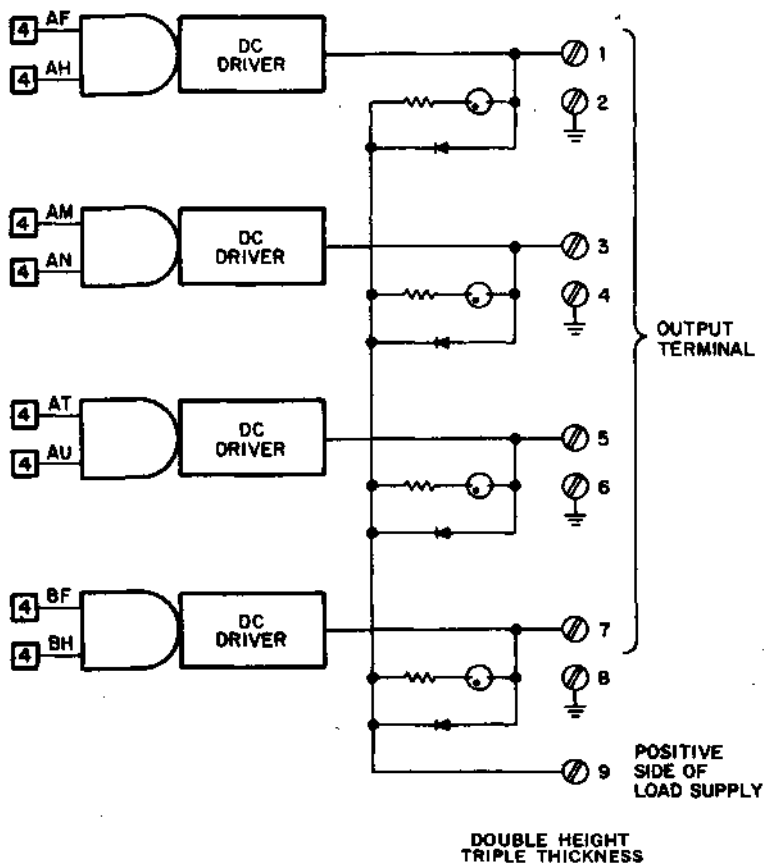

See the application section for wiring information and logic diagrams of several stepping motor applications.

Terminals 2, 4, 6 and 8 must be connected directly to the negative terminal of the load power supply or damage to the module will result from high currents.

**DC DRIVER**  
**K658**

**K**  
**SERIES**

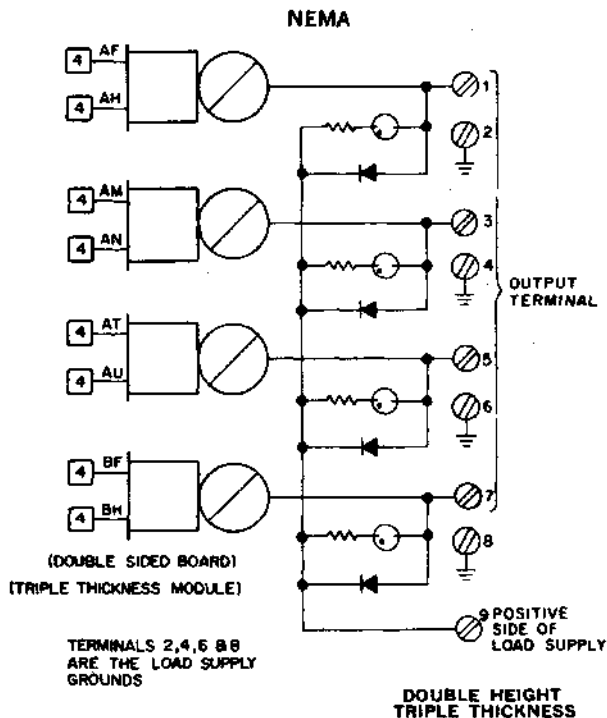

**K658 4 AMP DRIVER**

Each circuit of this versatile driver can deliver up to 4 amperes at up to 125 volts. Like the K578, K656 and K614, this module has integral clamp-type terminals and neon indicator lamps. (Lamps are effective only at 90 volts and above.) This driver module is designed to be used with K724 interface shells. Positive side of load supply must be connected to protect output transistors from damage during turnoff transient.

**K658—\$128**

MIL

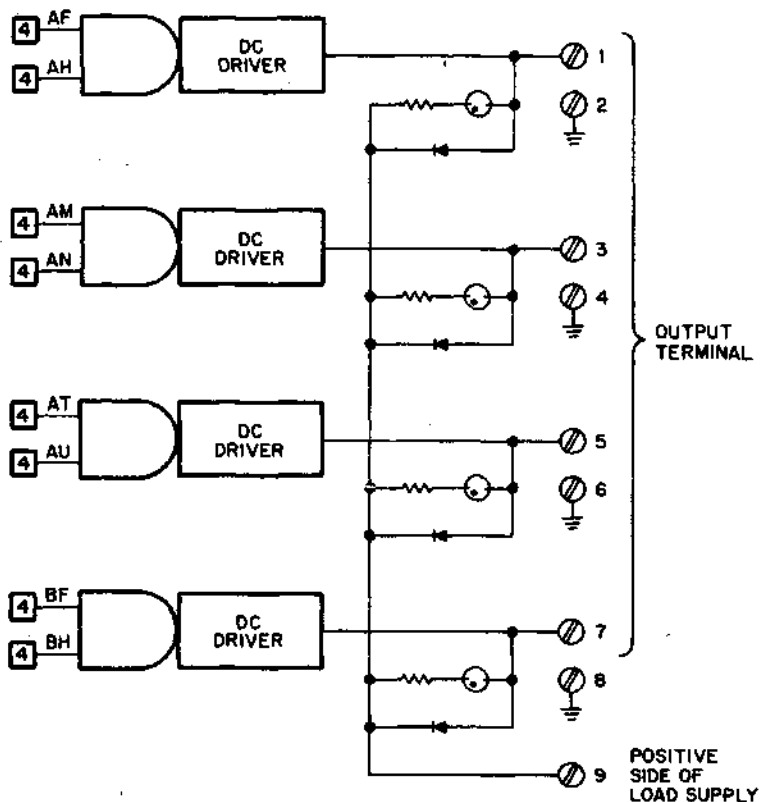

DOUBLE HEIGHT  
TRIPLE THICKNESS

See the application section for wiring information and logic diagrams of several stepping motor applications.

Terminals 2, 4, 6 and 8 must be connected directly to the negative terminal of the load power supply or damage to the module will result from high currents.



# DECIMAL DECODER AND NIXIE DISPLAY

K671

K  
SERIES

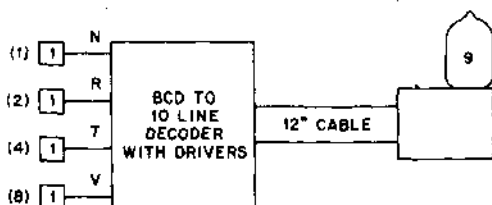

This module has two parts separated by a 1-foot ribbon cable. One part plugs into any module socket, the other contains a side-viewing Burroughs type B-5440 long life NIXIE glow tube on a mounting board. Four connections to corresponding module socket pins of a K210 or K220 binary-coded decimal counter completes the input wiring. The display tube board attaches with two screws to a K771 supply for both mechanical mounting and power supply electrical connections. Displays up to 6 digits long can be stacked on each K771 supply. Stacked digits have 0.8" mounting centers. See Construction Recommendations before assigning module locations. A Burroughs Type B-5442 NIXIE + and - glow tube can also be used in the K671. Ground pins N and V. Let pin R float and put input on pin T. Pin T is high for +, low for -.

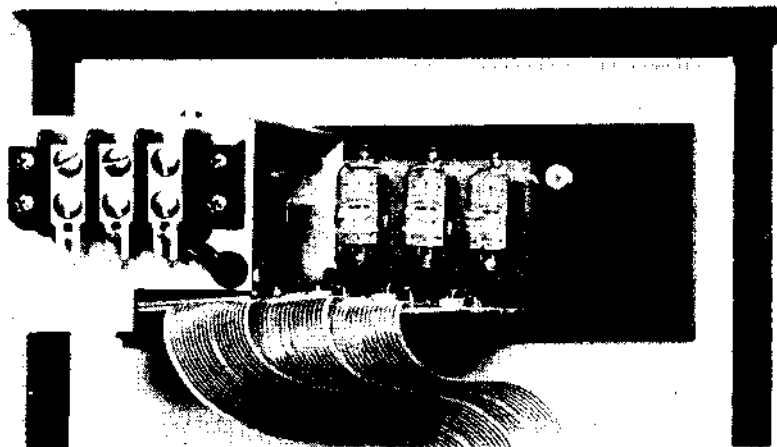

K671—\$55

# LAMP DRIVERS

K681

**K**  
**SERIES**

NEMA

MIL

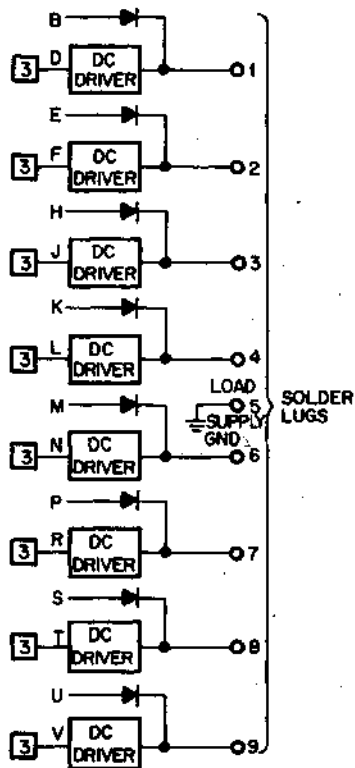
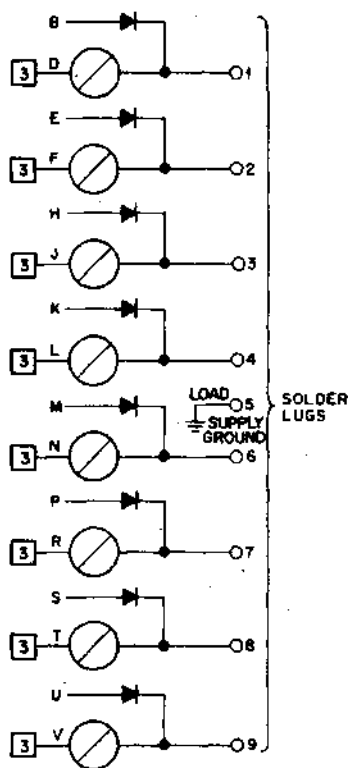

## K681 LAMP DRIVER

These eight-circuit modules drive external loads through 9-conductor cable soldered to split lugs at the handle end by the user. Strain relief holes are prepunched in the board. Logic "0" turns the driver off, logic "1" turns it on.

Pin connections via diodes to outputs facilitate production automatic module testing while isolating system wiring from high voltages. Circuits are not slowed, and these connections are not recommended as output tiepoints unless exceptional care is taken to prevent noise and damaging voltages from degrading system reliability. (See Fixed Memory application note.)

**K681—\$15**

MODULE TYPE	OUTPUT RATINGS		
	RESISTIVE	INDUCTIVE	INCANDESCENT LAMPS
K681	18V, 30ma	18V, 30ma with added suppression diodes (K784)	Lamps rated 18V, 40ma operated at 12V to reduce current to 30 milliamperes.

Note greatly reduced ratings on tungsten loads. Lamp filaments draw typically ten times more current at turnoff than when hot, resulting in very high transistor dissipation if supply voltage is high. Series current limiting resistors or shunt preheat resistors could be used to limit surge in certain cases, but ratings above assume this would be awkward or impractical.



K681

Solder lugs on the K681 shown above are numbered 1 to 9 from left to right.

# LAMP DRIVERS

K683

**K**  
SERIES

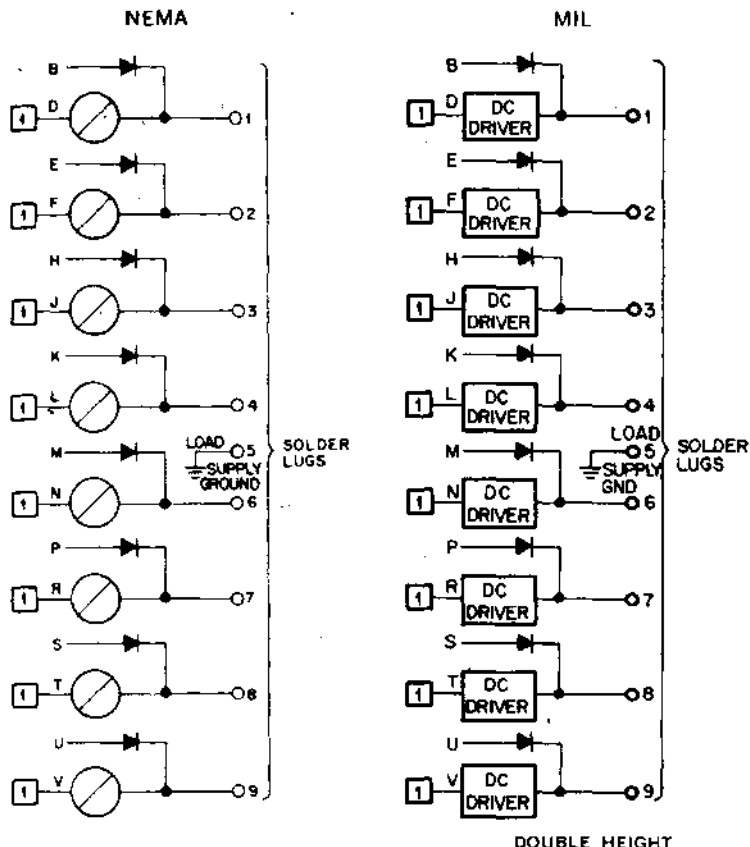

K683 LAMP DRIVER

These eight-circuit modules drive external loads through 9-conductor cable soldered to split lugs at the handle end by the user. Strain relief holes are prepunched in the board. Logic "0" turns the driver off, logic "1" turns it on.

Pin connections via diodes to outputs facilitate production automatic module testing while isolating system wiring from high voltages. Circuits are not slowed, and these connections are not recommended as output tiepoints unless exceptional care is taken to prevent noise and damaging voltages from degrading system reliability. (See Fixed Memory application note.)

K683—\$30

MODULE TYPE	OUTPUT RATINGS		
	RESISTIVE	INDUCTIVE	INCANDESCENT LAMPS
K683	55V, 250ma	55V, 250ma with added suppression diodes (K784)	Lamps rated 40ma, to 48V; Lamps rated 60ma, to 28V; Lamps rated 80ma, to 18V; Lamps rated 100ma, to 12V

Note greatly reduced ratings on tungsten loads. Lamp filaments draw typically ten times more current at turnon than when hot, resulting in very high transistor dissipation if supply voltage is high. Series current limiting resistors or shunt preheat resistors could be used to limit surge in certain cases, but ratings above assume this would be awkward or impractical.

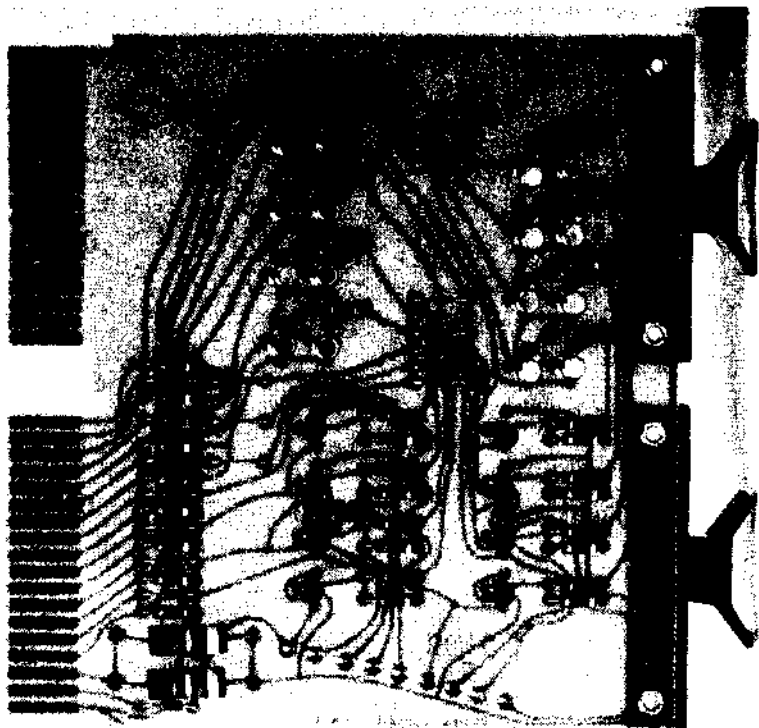

K683

Solder lugs on the K683 shown above are numbered 1 to 9 from left to right.

# EIA OUTPUT CONVERTER

K696

**K**  
**SERIES**

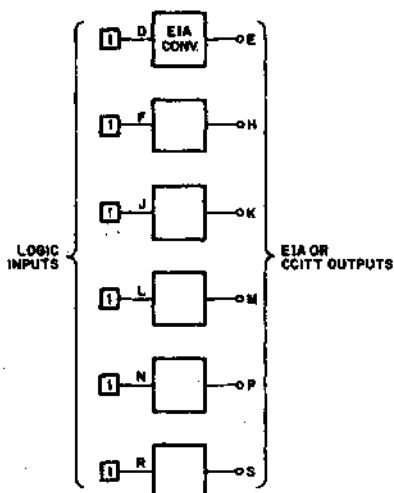

EIA OUTPUT CONVERTER K696

This bipolar non-inverting driver converts standard logic levels to either the American EIA or the European CCITT standard signals for data transmission. Power can either be 6.3 VAC  $\pm 10\%$  60Hz on pin B for EIA levels (at least  $\pm 5$  volts) or 9.0 VAC  $\pm 10\%$  50Hz on pin B for CCITT levels (at least  $\pm 6$  volts). Limited output current capability results in risetimes of several microseconds for capacitive loads of a few thousand picofarads, limiting the maximum baud rate to 5K baud. One ampere of AC can supply up to 32 K696 modules. Keep AC leads short to maintain voltage.

Please observe that noise and interference can enter a digital system through any wires that pass through a noise field. K696 modules should be located at the edge of the system, and communications wiring should not be allowed to lie close to logical wiring for more than a few inches. A high impedance probe may be used to monitor the half-wave rectified and filtered negative internal supply at pin T (5 K $\Omega$  series resistance).

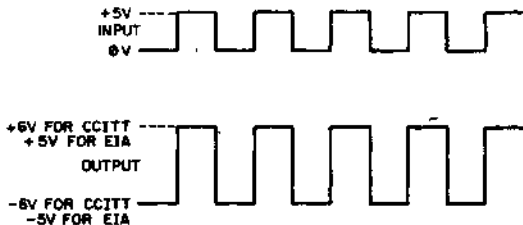

**K696—\$44**

## HARDWARE SUMMARY TABLE

FUNCTION	PRODUCT	
Accessories for Interface Modules (K5XX, K6XX)	K716	Interface Block
	K724	Interface Shell, Power wiring only
	K782	8 Terminals
	K784	8 Terminals with Diodes
Power	K730	10 VDC and approx 16VDC
	K731	1 Amp Regulator
	K732	2 Amp Slave Regulator
	K741	2 Amp Transformer
	K743	3 Amp Transformer with Auxiliary Winding
	H710	5 Amp Low Ripple Supply
	K771	NIXIE Supply
Mounting Hardware and Connectors	K940	Mounting Foot for K941
	K941	Mounting Bar
	K943	64 Module 19" X 5 1/4" Mounting Panel
	K980	End Brackets
	K982	Mounting Panel
	1907	Hold-Down and Cover
	H001	Cover Supports
	H920	Module Mounting Drawer
	H800	8-Connector Block
	H802	Single Connector
Wiring Aids	913	Grip Clip Logic Wiring Patchords
	914	Power Wiring Jumpers
	932	Bussing Strip
	934	Wire for Wrapping
	H810	Pistol Grip Hand Wire-Wrap Tool
	H812	Unwrapping Tool
Miscellaneous	K791	Test Probe
	W980	Module Extender
	W992	Clad Board, Single Size
	W993	Clad Board, Double Size
	H830	Handle Riveting Tool for Clad Boards
	K080	Cable Connector
	W021	Cable Connector, Logic Only
	W023	Cable Connector, Logic and Power
	W028	Cable Connector, Component Lugs

# INTERFACE BLOCK K716

# K SERIES

An important hardware feature of the K Series system is the K716 Interface by electricians. The logic modules interconnect to the K716 by plug-in ribbon cables.

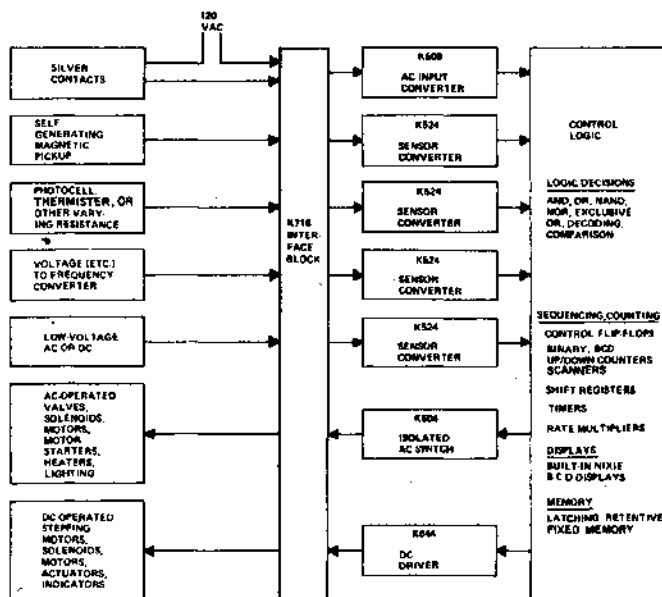

## TYPICAL CONTROL APPLICATIONS FOR K SERIES MODULES INTERFACED BY K716

**Contacts:** Ordinary silver contacts of the kind found in limit switches, pressure switches, and pushbuttons work best when operated with healthy levels of both line voltage and load current. The sparking that results prevents buildup of contact surface contamination. To assure reliable switching, isolation transformers in the K716 provide a reactive load for switched 120 vac pilot voltages. The K508 AC Input Converter ignores contact bounce. Hash filters in the module, and attenuation in the isolation transformer built into the K716, reduce electrical noise. Built-in indicators permit quick maintenance checks.

The K716 Interface Block serves as an interconnection interface for those K Series modules that communicate with external equipment. External field wiring terminates at a 24-terminal screw connection block that accepts plain stripped wire up to 14 guage. No separate crimped or soldered terminals are required.

K716—\$75



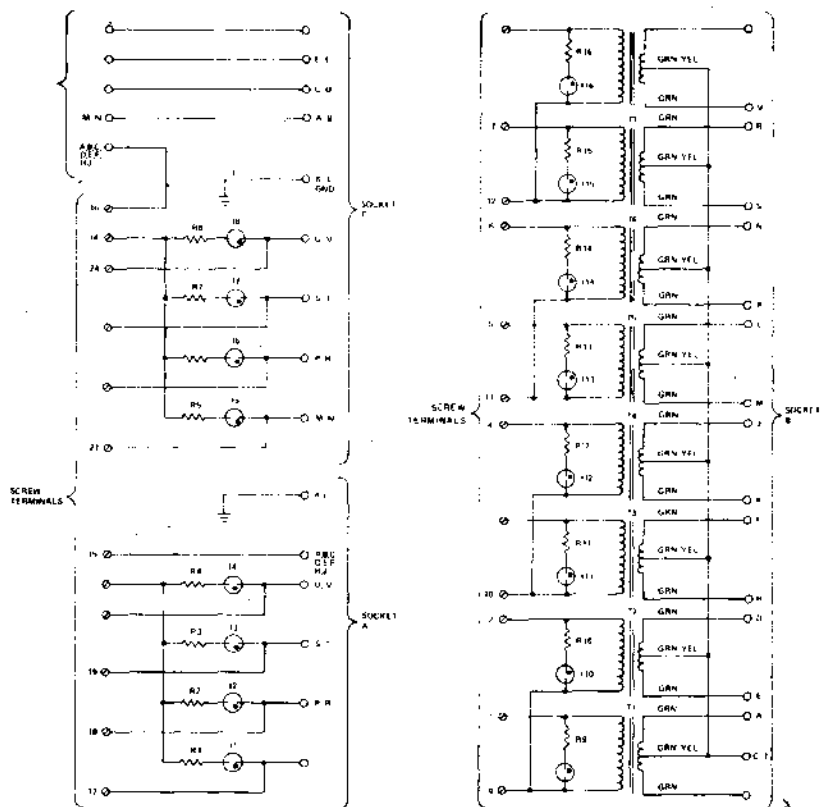

### K716 INTERFACE BLOCK SCHEMATIC

Ribbon cables from the K Series interface modules connect to printed circuit board sockets on the K716. This allows the K716 terminal block to mount on the rear panel of a NEMA enclosure for the convenience of electricians, while the digital system itself mounts on the door for easy access to both modules and logic wiring. The ribbon cable makes neat, simple wiring layouts and easy flexing at the hinge.

The three sockets in the K716 terminal block contain the same module-connector system used for the modules themselves, permitting quick disconnect of the entire logic system without affecting reliability. This arrangement, together with the K940-K941 bolt-on mounting hardware, allows initial check-out of control systems away from the site, as well as minimizing downtime in case of failure. (See Construction Recommendations.) The cable sockets have the same reliable gold contacts as K Series module sockets.

Socket B, for use with the K508 AC input converter, is fed by eight isolation, stepdown and contact loading transformers contained within the aluminum shell of the K716. The transformer primaries receive 120-volt pilot signals from external contact closures. Each input is monitored by a neon indicator.

Sockets A and C are for use with K524, K604, and K644. Neon indicators are provided to monitor the outputs of the K604 Isolated AC Switch module.

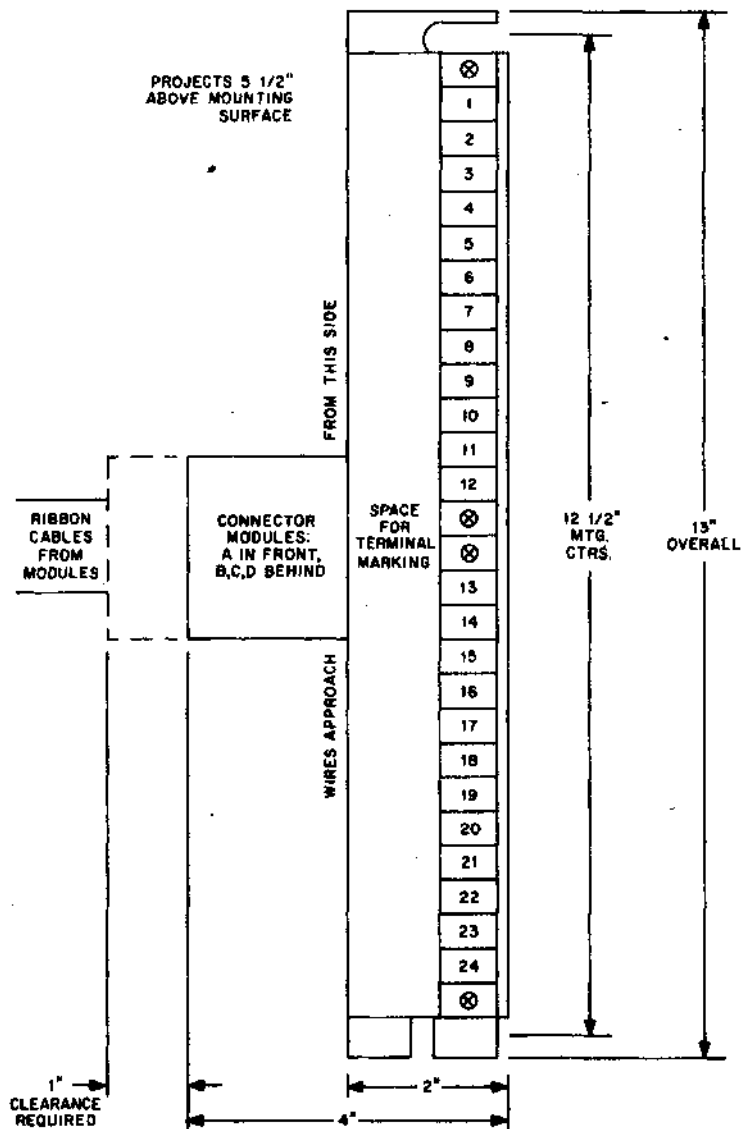

**K716 INTERFACE BLOCK  
FRONT VIEW**

The drawing above shows approximate dimensions of the K716. Mounting slots clear no. 10 screws and allow compensation for mounting screw location tolerances. See first Application Note "Construction Recommendations."

All neon indicators are located within the K716 shell, visible at the rear of associated screw terminals.

Socket D, normally terminated by a shorting plug, runs all return lines from connector C to a common point. If the shorting plug is removed, independent wiring of connector C return leads for K524 or K604 modules is possible. A W033-06F-W033 cable connector (\$15) must be installed between socket D and socket A. An extra 2-inch clearance is required by this connector board. Independent wiring provides connections for four two-wire circuits instead of 8 circuits with bussed returns.

Below is a recommended mounting pattern for combining many interface blocks. This pattern can be extended provided the 30" reach of ribbon is not exceeded.

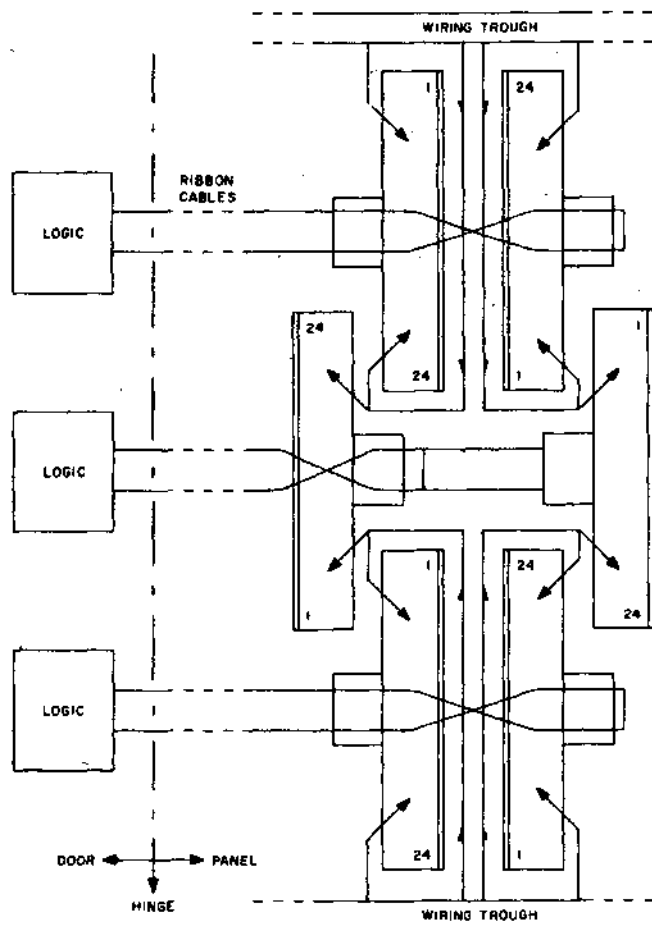

K716'S IN INDIVIDUAL ENCLOSURE

## INTERFACE SHELL

K724

**K**  
**SERIES**

Unlike the K716 Interface Block, the K724 Interface Shell does not contain any electronic components. Instead, it provides the connectors and the mechanical support for self-contained interface modules K578, K614, K615, K650, K652, K656 and K658. Up to four K578, K614 or K615 modules or two K650, K652, K656 or K658 modules may be installed, with eight module sockets remaining for decoding or gating modules. The limit of two DC Driver modules is due to the fact that they cannot be reversed in their connector sockets.

Convenient wiring channels are obtained between units if they are mounted on 12" centers vertically and 6" centers horizontally. This way a total of up to 32 input converters and 16 output converters fit in one square foot of panel space, along with up to 16 logic modules.

The K724 provides only logic power and ground connections between all but two sockets. It is primarily intended for very simple logic systems or for large systems where all input and output logic levels are connected to a separate logic unit by connector cables.



---

K724—\$55

---

# GENERAL PURPOSE MODULE

K730

**K**  
**SERIES**

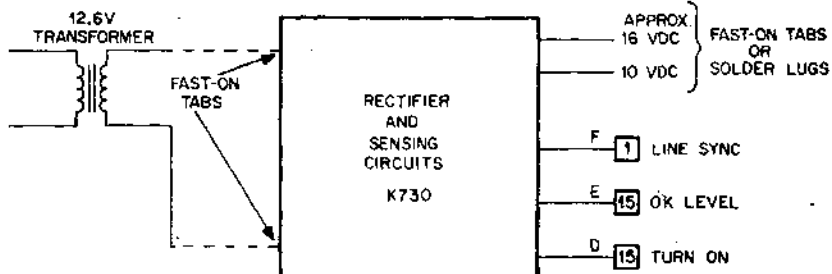

The K730 is a general purpose module that can be used with any +5 volt power supply to generate the turn on and power OK signals that are normally provided by the K731.

If an external 12.6 volt transformer is connected to the fast-on tabs at the handle end of the module, a 2 amp diode bridge power supply and a line sync will also be available. (Line sync will not operate without a load on either DC output).

The line sync output on pin F allows a K113 or K123 gate to switch in synchronism with ac supply zero crossings. This permits the line frequency to drive a realtime clock, or serve as the standard in a phase-locked loop with K303 timers, where higher frequencies must be synchronized with the line. Line sync fanout is limited to 1 ma (for high fanout, use K113 or K123 for distribution).

The bridge power supply has two separate fused outputs; approximately 16 VDC and 10 VDC. The direct output is fused for 2 amps and the diode string output is fused for  $\frac{3}{4}$  amps. The diode string output may be used with the K580 switch filter as a source of +10 volts for contact sensing. Space is provided on the board for an electrolytic capacitor to be added if a filtered supply is desired. All supply outputs are brought out through fast-on tabs at the handle end of the module. The auxiliary winding on the K743 transformer may be used, however, any 12.6 VAC transformer may be used as long as it does not have a grounded center tap.

The turn-on output on pin D goes to ground during the power-up transient and remains at ground until at least 30 ms after the supply voltage has reached its quiescent value. It may be used to initialize the flip-flops to a known voltage.

The OK level output (pin E) goes to ground when the +5 VDC supply voltage at pin A reaches 4.5 volts, and returns positive when less than 4.5 volts is available. It is normally used as an enabling input to the K273 Retentive Memory module.

K730—\$19

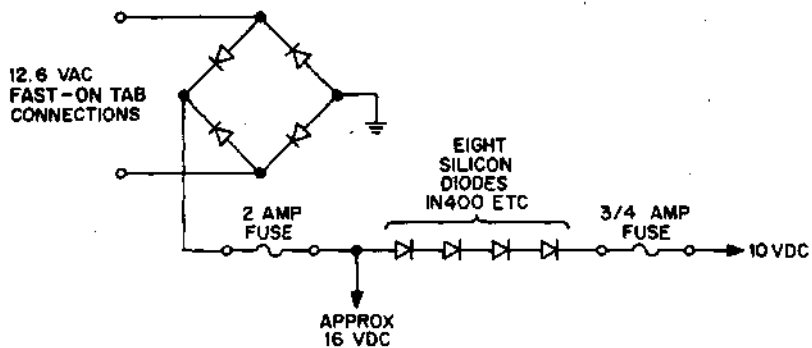

GETTING APPROXIMATELY +16 VDC AND +10 VDC  
FROM K730

**SOURCE MODULE**  
**K731**

**K**  
**SERIES**

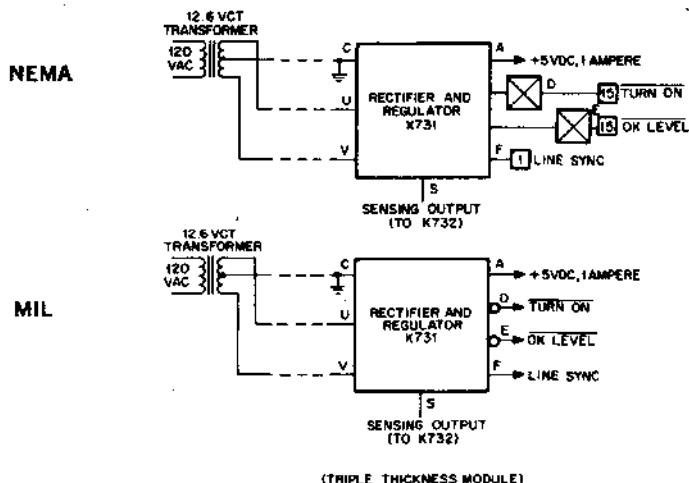

**TRIPLE THICKNESS**

The K731 supplies +5 volt DC power to pin A of all K Series modules and provides several specialized once-per-system control functions. Any source of center-tapped 12.6 v (50 or 60 Hz) allows the K731 to deliver up to 1 amp dc, which is sufficient to operate most typical control systems of up to 32 modules. The K731 is short-circuit proof.

This module is normally plugged into one of the innermost sockets on a K941 mounting bar, where its large components occupy space otherwise unused.

The turn-on output goes to ground during the power-up transient, and remains at ground until after the supply voltage has fully reached its quiescent value. It may be used to initialize flip-flops to a known starting condition.

The OK level output goes to ground when the supply voltage reaches 90% of its final value, and returns positive when less than 90% of full voltage is available. It is normally used as an enabling input to the K273 Retentive Memory module.

The line sync output allows a K113 or K123 gate to switch in synchronism with ac supply zero-crossings. This permits the line frequency to drive a real-

**K731—\$30**

time clock, or serve as the standard in a phase-locked loop with K303 timers, where higher frequencies must be synchronized with the line. Line sync fanout is limited to 1 ma (for high fanout, use K113 or K123 for distribution). None of the K731 logic outputs may be used to obtain the OR function, and they may not be wired to any other output.

K731 delivers up to 1 ampere when used with a 12.6 volt transformer rated for 105-130 volt line. For 5% input voltage reduction (12.0v transformer or 100 volt line) the output current capability decreases 10%.

The K731 can also be used with M Series modules provided overvoltage protection is not necessary, since voltage regulation is  $\pm 5\%$ .

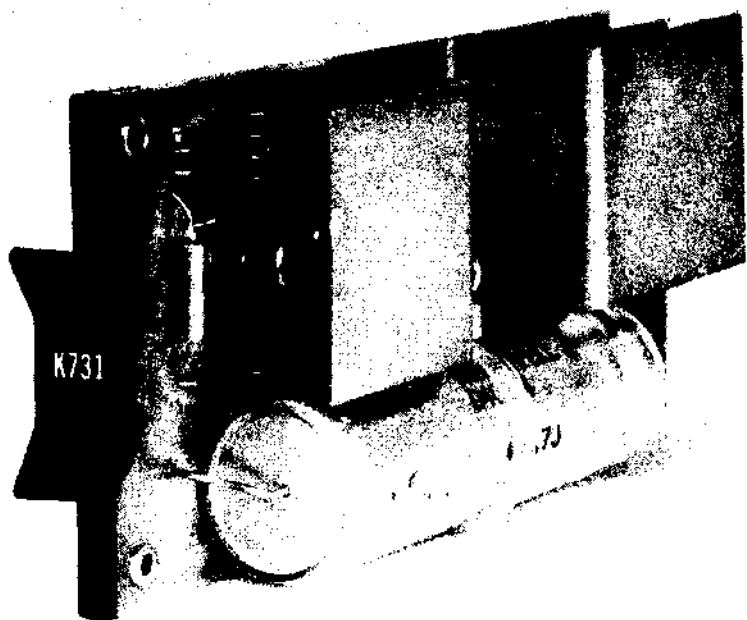



**POWER SUPPLY**  
**H710**

**POWER  
SUPPLY**

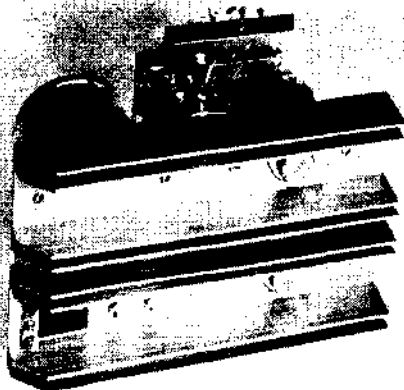

The H710 power supply is ruggedly built, low cost, regulated, floating output, five volt power supply that can be mounted in an H920 chassis drawer or used as a free standing unit.

**INPUT VOLTAGE:** 105-125 VAC  
or 210-250 VAC 47-63 HZ

**OUTPUT VOLTAGE:**  
5 vdc.

**P-P RIPPLE**  
Less than 20 mv.

**OUTPUT CURRENT:**

0.5 amps, short-circuit protected for parallel supply operation.

**LINE AND LOAD REGULATION:**

The output voltage will not vary more than 50 mv. over the full range of load current and line voltage.

**REMOTE SENSING:**

Remote sensing is provided to correct for loss due to long lines. These sensing inputs should be connected to the most distant point on the +5 and ground buss system. When shipped from the factory, the remote sensing inputs are jumpered to their respective outputs. These leads are especially useful in systems that require maximum repeatability from K303 timers in the millisecond region.

**OVERVOLTAGE PROTECTION:**

The output is protected from transients which exceed 6.9 volts for more than 10 nsec. However, the output is not protected against long shorts to voltages above 6.9 volts.

---

H710—\$200

---

# SLAVE REGULATOR K732

# K SERIES

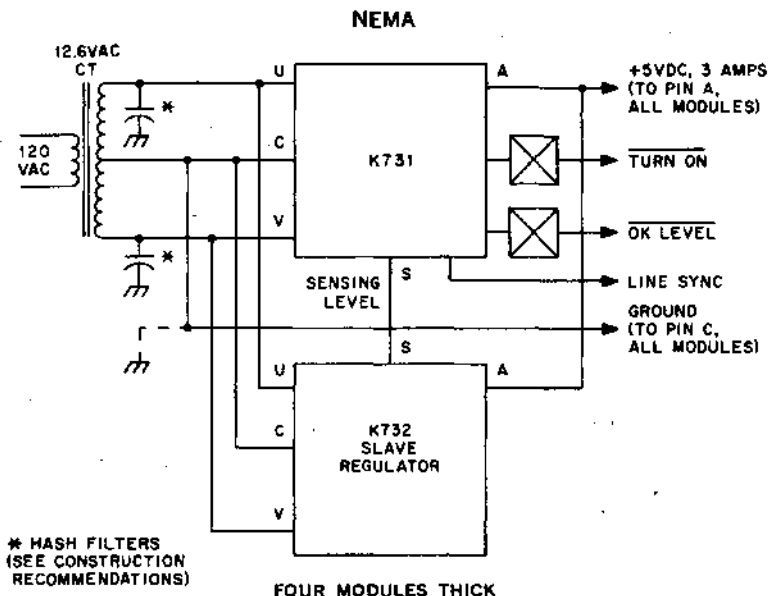

This module is normally tied to corresponding pins A,C,S,U, and V of a K731 Source. For each unit of current emitted by the K731, the K732 emits two. Up to three K732 slaves can be controlled by a single K731 for a total system current of 7 amperes.

In high-current systems, use short heavy wires for transformer secondary connections. Loss of 5% of secondary voltage in either ground return or transformer output leads will reduce regulator current ratings more than 10%.

Tabs near the handle end of the K732 may be connected to K741 or K743 transformers by using convenient 914 Power Jumpers. Then by wiring pins U and V to corresponding pins on K731, AC connections are provided through the K732 to the source module. To avoid loss of regulation, do not connect a K732 until enough modules have been plugged in to draw a reasonable current (several hundred milliamperes).

For self contained low-ripple supplies see H710, and H716.

**K732—\$27**

# MIL

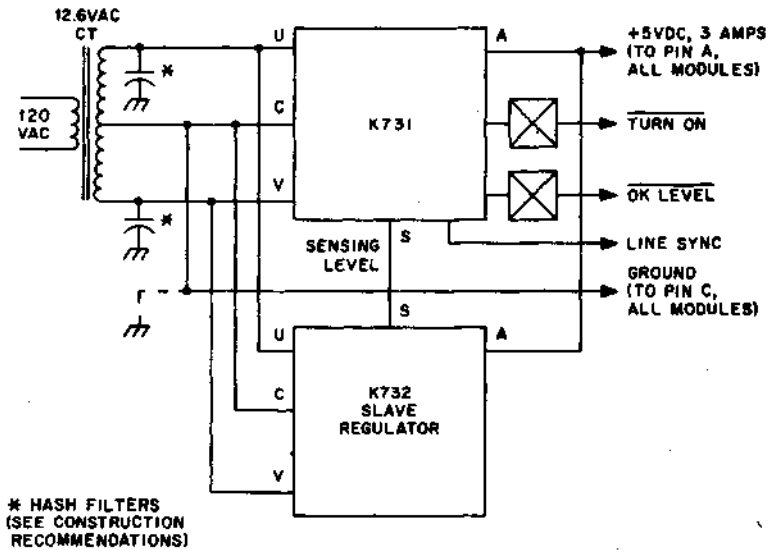

FOUR MODULES THICK

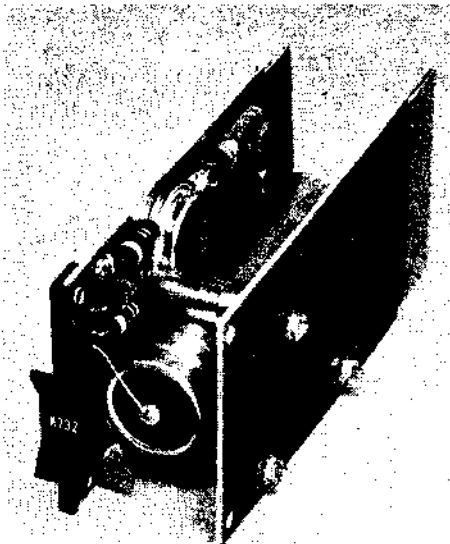

One K731 plus up to 3 K732 can provide from 1 to 7 amperes at +5v.

### MODULE CHARACTERISTICS

MODULE	HEIGHT	THICKNESS	NUMBER CIRCUITS	UNIQUE CHARACTERISTICS	CURRENT REQUIREMENTS (Ma)	PRICE
K003	1	1	3	No drive capability, for expansion only	3	\$ 5
K012	1	1	3	No drive capability, for expansion only	12	\$ 8
K026	1	1	3	No drive capability, for expansion only	6	\$ 8
K028	1	1	1	No drive capability, Pin C should not be bussed to ground unless B=C function is not used.	8	\$ 8
K080	1	1	1	Cable connector.	0	\$ 3
K112	1	1	3	1KHz maximum speed with slowdown on one circuit to 50Hz; both AND and OR expandable	17	\$12
K113	1	1	3	AND and OR expandable; slowdown on one circuit to 5KHz	17	\$11
K122	1	1	3	1KHz maximum speed with slowdown on one circuit to 50Hz; both AND and OR expandable	18	\$13
K123	1	1	3	Both AND and OR expandable; slowdown on one circuit to 5KHz	18	\$12
K124	1	1	3	Not expandable; slowdown on one circuit to 5KHz.	21	\$14
K134	1	1	4	Common AND input; can only be AND expanded	23	\$13
K135	1	1	4	Common AND input; can only be OR expanded Pin K Fan-in varies	22	\$13

## MODULE CHARACTERISTICS

MODULE	HEIGHT	THICKNESS	NUMBER CIRCUITS	UNIQUE CHARACTERISTICS	CURRENT REQUIREMENTS (Ma)	PRICE
K138	1	1	8	Single input inverters	28	\$24
K161	1	1	1	Slowdown on zero output only; inputs need 0 and +5 volt levels	45	\$25
K171	1	1	1	Output has no drive capability and must be connected to an AND expansion node of any gate	16	\$13
K174	1	1	1	Output has no drive capability and must be connected to the OR expansion node of any gate	12	\$24
K184	1	1	1	Capacitance added to Pin J for pulse width variation	56	\$25
K201	1	1	2	Temperature range 0° to 65°C; 1KHz maximum speed	130	\$39
K202	1	1	2	Temperature range 0° to 65°C; slowdown provided on Pin B	120	\$27
K206	1	1	4	Temperature range 0° to 65°C; common read-IN enable	50	\$20
K210	1	1	1	Temperature range 0° to 65°C	150	\$27
K211	1	1	1	Temperature range 0° to 65°C	60	\$20
K220	2	1	1	Temperature range 0° to 65°C; only logic "1's" can be preset using the read-in inputs	220	\$55
K230	2	1	1	Temperature range 0° to 65°C; only logic "1's" can be preset, all pin connections on upper half	150	\$40

MODULE	HEIGHT	THICKNESS	NUMBER CIRCUITS	UNIQUE CHARACTERISTICS	CURRENT REQUIREMENTS (Ma)	PRICE
K271	1	2	1	Maximum angle from vertical of 30°	40	\$40
K273	1	2	3	Maximum angle from vertical of 30°	50	\$85
K281	1	1	1	Contains eight four-bit words	0	\$10
K282	2	1	1	Contains eight 16-bit words	0	\$40
K301	1	1	1	Double thickness with timer control mounted. Connect pins P and S for ONE SHOT	15	\$15
K303	1	1	3	Double thickness with timer control mounted.	30	\$27
K323	1	1	3	Double thickness with timer control mounted.	35	\$35
K333	1	1	3	Split lugs for mounting delay capacitors	29	\$23
K371	1	1	1	When three controls are mounted on a module, that module must go at the end of a K941 mounting bar		\$11
K373						\$11
K374						\$15
K375						\$11
K376						\$15
K378						\$15
K410	2	1	5	Pin connections made on B connector half. Lamps are Hudson #2309, 10 volt 40Ma rated Module requires 120VCT 50-60 cps	200	\$18

MODULE	HEIGHT	THICKNESS	NUMBER CIRCUITS	UNIQUE CHARACTERISTICS	CURRENT REQUIREMENTS (Ma)	PRICE
K415	2	2	1	Pin connections made on B connector half. Illegal number inputs (11-15) light two numeral filaments. Module requires 12.6VAC 50-60 cps at 80Ma capability	43	\$46
K420	2	1	3	Pin connections made on B connector half	17	\$33
K422	2	2	2	Pin connections made on B connector half; outputs have no drive capability and are AND expansion inputs only	0	\$27
K424	2	2	2	Pin connections made on B connector half output has no drive capability and can be used as an expansion input only	2	\$27
K432	2	2	2	Pin connections made on B connector half; optional third circuit available if customer inserts components	0	\$33
K501	1	1	4	Provides 1 volt of hysteresis	45	\$25
K508	2	1	8	Module has a 30" ribbon cable and cable connector board which is triple thickness	65	\$44
K522	1	1	1	Solder lugs are made for inputs	25	\$25
K524	2	1	4	Module includes a 30" ribbon cable and single height connector board	35	\$98
K531	2	1	1	All pin connections on A connector half	50	\$70
K578	2	3	8	Module may be reversed in socket. Neon indicators are effective for 90VDC and above. AC inputs made to clamp-type terminals.	0	\$80

MODULE	HEIGHT	THICKNESS	NUMBER CIRCUITS	UNIQUE CHARACTERISTICS	CURRENT REQUIREMENTS (Ma)	PRICE
K580	1	1	8	Input connections are made to solder lugs (uses separate supply)	0	\$28
K581	1	1	8	Input connections are made to solder lugs. +5VDC must be applied to Pin A. Current re- quired per contact closed	22	\$20
K596	1	1	6	Temperature range 0° to 65°	30	\$20
K604	2	1	4	Module includes a 30" ribbon cable and con- nector board. Current with all circuits off Additional current per circuit on	40 20	\$110
K614	2	3	4	Module may be reversed in socket. Neon in- dicators are effective for 90VDC and above. AC input connections are clamp-type connec- tors Current with all circuits off Additional current per circuit on	40 20	\$88
K615	2	3	4	Module may be reversed in socket. Neon in- dicators are effective for 90VDC and above. AC input connections are clamp-type connectors Current with all circuits off Additional current per circuit on	56 28	\$92
K644	2	1	4	Module includes a 30" ribbon cable and con- nector board for outputs. Current with all circuits off Additional current per circuit on	10 160	\$66

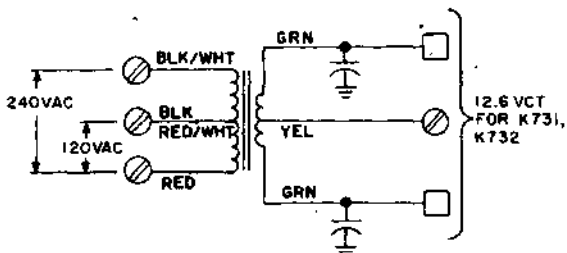
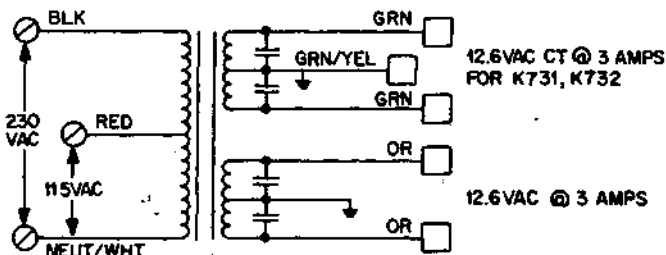

MODULE	HEIGHT	THICKNESS	NUMBER CIRCUITS	UNIQUE CHARACTERISTICS	CURRENT REQUIREMENTS (Ma)	PRICE
K650	2	3	4	DC output connections are clamp-type connectors Current with all circuits off Additional current per circuit on	8 160	\$40
K652	2	3	4	DC output connections are clamp-type connectors Current with all circuits off Additional current per circuit on	10 160	\$50
K656	2	3	4	Clamp-type output connections. Neon indicators effective for 90VDC and above. Current with all circuits off Additional current per circuit on	10 160	\$80
K658	2	3	4	Clamp-type output connections. Neon indicators effective for 90VDC and above. Current with all circuits off Additional current per circuit on	10 350	\$128
K671			1	Two part module with one foot ribbon cable	13	\$55
K681	1	1	8	Solder lugs for output connections	16	\$15
K683	1	2	8	Solder lugs for output connections	160	\$30
K696	1	1	6	Requires 6.3 VAC 50-60 cps	7	\$44
K730	1	2	1	Requires 12.6 VAC for 16VDC and 10VDC	34	\$19

**POWER TRANSFORMERS****K741, K743****K  
SERIES****K741 TRANSFORMER WITH FILTER****K743 TRANSFORMER WITH FILTER**

These hash-filtered, 50/60 Hz transformers supply K731 Source and K732 Slave Regulator modules. The K743 also provides an auxiliary winding for use with K580 Dry Contact Filters, K681 or K683 Lamp Drivers (requires additional bridge rectifier) and the K730 Source Module. Type 914 Power Jumpers are convenient for connecting to tab terminals on these transformers and on the K732 and K943. Both transformers have holes at the corners of the chassis plate for mounting on K980 endplates:

	PLATE DIMENSIONS	HOLE CENTERS	MATCHING K980 Ctrs.
K741	3½" x 5"	2½" x 3⅜"	2½"
K743	4⅞" x 4⅞"	4" x 3⅜"	4"

The K741 is sufficiently light in weight to be mounted on one side only, as at the end of a K943 mounting panel.

K741—\$30  
K743—\$45

The table below shows how to obtain various currents. Line voltages within  $\pm 10\%$  from nominal and short, heavy secondary wires are assumed. One K731 is required in each case.

60 Hz	50 Hz	K732	TRANSFORMER
0.1-1A	0.1-0.8A	0	K741 or K743
0.5-2A	0.4-1.6A	1	K741 or K743
1-3A	0.8-2.4A	1	2 K741s or K743
2-4A	1.6-3.2A	2	2 K741s or 2 K743s
3-5A	2.4- 4A	2	3 K741s or 2 K743s
4-6A	3.2-4.8A	3	3 K741s or 2 K743s
5-7A	4-5.6A	3	4 K741s or 3 K743s

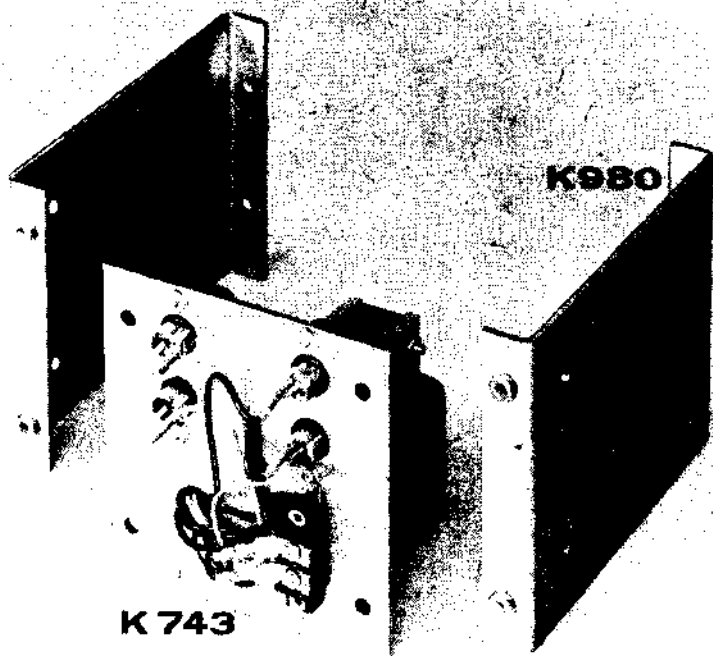

## DISPLAY SUPPLY

K771

**K**  
SERIES

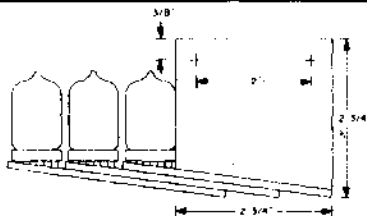

(SHOWN WITH 3 K671S)

Shown above from the viewing side, the K771 supplies power and a convenient two-screw mounting for up to 6 K671 display tubes. Display tubes are stacked to the left, the first tube board being attached to the K771. The second tube board attaches to the first, and so on. Board mounting screws provide both mechanical mounting and electrical power connections. The two panel mounting screw locations dimensioned above have no. 6 steel threaded inserts. Several 1" high holes using a standard chassis punch may be cut on 0.8" centers for viewing display tubes. To seal opening against dust, a 3" by 3-6" piece of Lucite® or Plexiglas® may be assembled between display and mounting surface. Power 120 VAC enters the supply from a terminal strip at the rear. Total depth behind mounting surface: 4".

K771—\$35

## TEST PROBE

K791

**K**  
SERIES

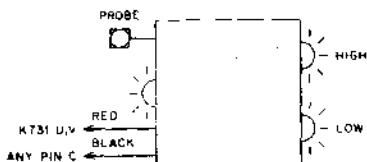

K791 TEST PROBE



This pocket test probe contains two pulse-stretching lamp drivers for visual indication of both transient and steady-state conditions. Neither indicator lights on an open circuit. A built-in test point illuminator adds convenience. The probe introduces negligible loading of the point under observation. The black wire connects to any pin C. The red wire gets ac power from the system supply transformer, pin U or V of K731. Probe is hollow and fits unwrapped end of H800W pins for hands-off use if desired.

K791—\$40

# TERMINALS

K782, K784

# K SERIES

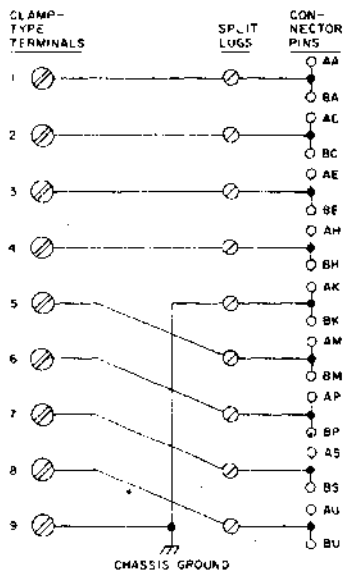

K782

DOUBLE THICKNESS  
DOUBLE HEIGHT

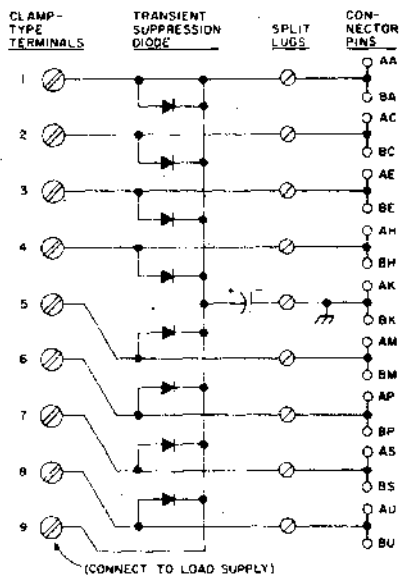

K784

DOUBLE THICKNESS  
DOUBLE HEIGHT

These two double size modules offer an alternative to the K716 for obtaining field wiring connections in K series systems. The K782 has straight-through connections for use with K524, K508, K604, or K644 modules. The K784 includes 60 v clamp diodes for protection of K681 or K683 modules driving inductive loads. Strain relief holes and split lugs on both boards adapt them for such modules as K580 and K683 where 9-conductor ribbon or individual wires will be used.

Connector pins are also provided, so the connector board of types like K524 or K604 can be plugged into a shared H800-F block and bussed connections used.

The photo at right shows one way that these modules may be mounted, by bolting through the holes provided and mounting on K980 brackets. The attachment of a K743 transformer to the K980 is also shown here.

K782—\$12  
K784—\$17

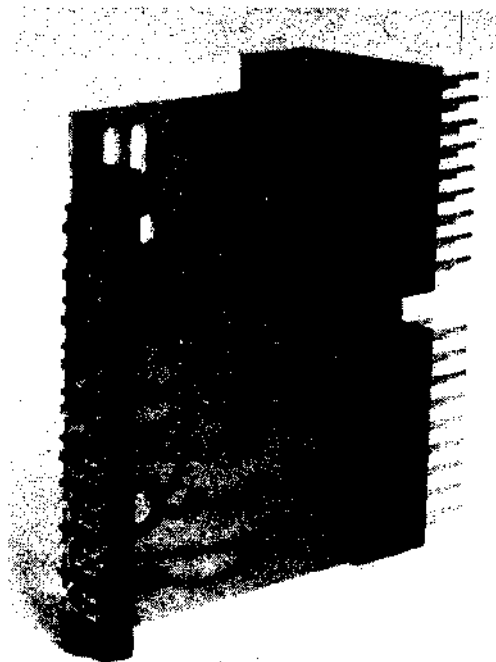

K782 TERMINAL

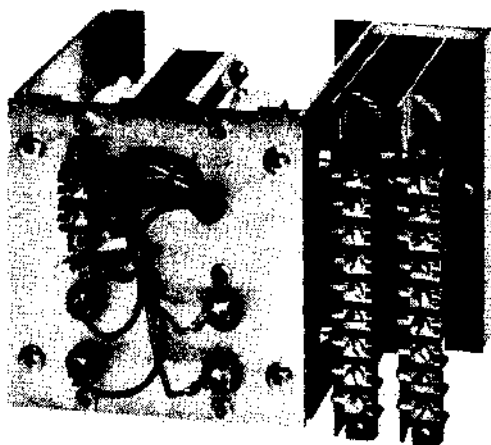

K782 TERMINALS WITH  
K743 AND K980

# MOUNTING HARDWARE

K940, K941

HARDWARE

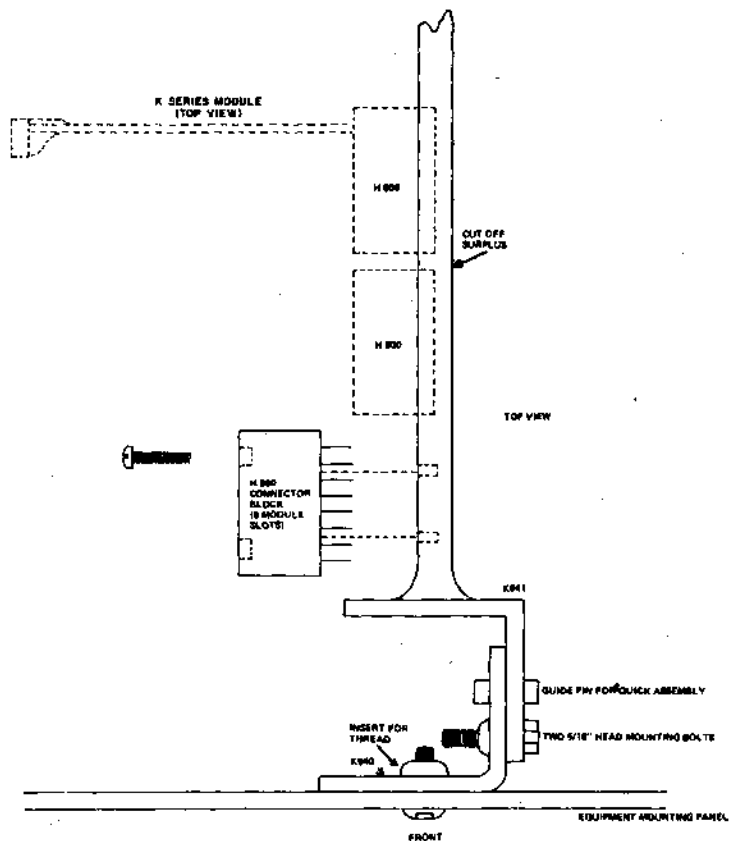

This convenient mounting hardware permits logic connector pin wiring to be done before logic is installed in the enclosure.

K940 is a mounting support that attaches to the enclosure. K941 is a removable bracket that mounts up to four H800 connector blocks. Any connections to external equipment are made through the ribbon connectors of interface signal modules (K508, K524, K604, K644) to the K716 Interface Block.

An installation of K-Series equipment in a NEMA-12 Enclosure is illustrated on the next page.

K940—\$4

K941—\$6

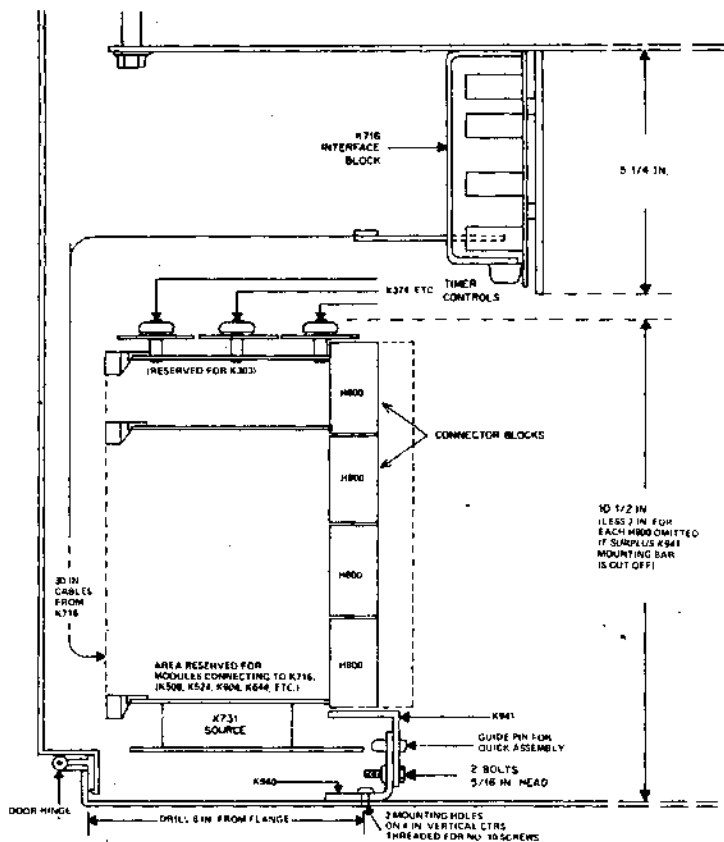

K940, K941 WITH K716 IN A NEMA-12 ENCLOSURE,  
16 IN. DEEP TOP VIEW

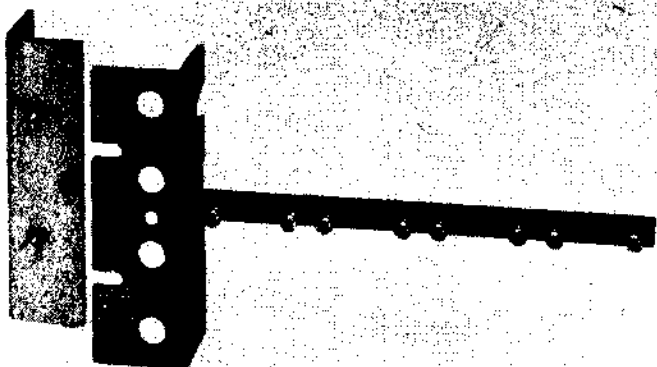



## 19" MOUNTING PANEL

K943-R, K943-S

HARDWARE

These low cost, 19" panels have sixty four, 18 pin connector sockets with either wire-wrap (S) or solder fork (R) contact pins. Each panel is shipped with connector blocks installed and pins A and C bussed.

No terminal strips are included in the K943, since power regulators K731 and K732 will normally be plugged in to make power connections. If hold-down is required to prevent modules from backing out under vibration, order a pair of end plates K980. These assemble by means of added nuts on the rear of the rack mount screws. They accept the painted 1907 cover plate, making a hold-down system that contacts the module handles and can allow flexprint cables to be threaded neatly out the end. Rack space: 5 1/4". See photos showing K943-S, K980, 1907, and H001.

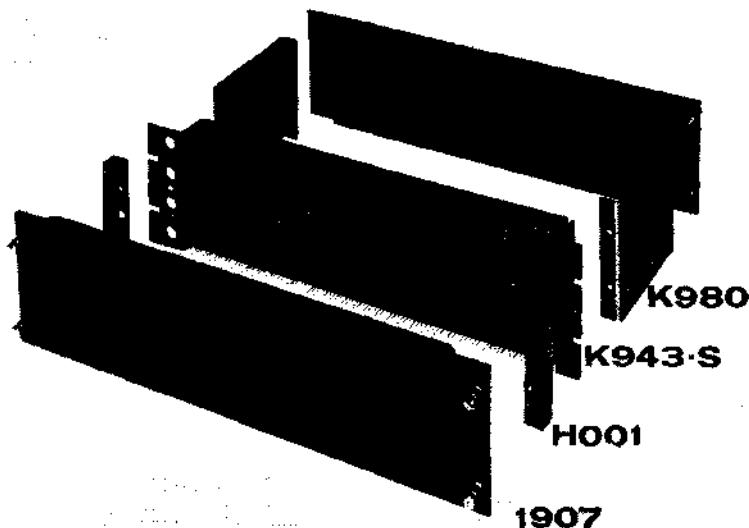

---

K943R—\$96  
K943S—\$96

---

## MOUNTING PANEL

H913, H914

HARDWARE

The H913 panel houses a 5v regulated supply and four low density H808 connector blocks. This allows 16 of either A, K, M, or W series modules to be used. Electrical and mechanical characteristics are given below.

The H914 panel houses 8 low density H808 connector blocks. The panel will hold 32 of either A, K, M, or W series modules. It can be used for expanding slot capacity in conjunction with H913 or alone using other options of voltage supply, e.g. K731, K732 combinations. Mechanical characteristics are like those of K943.

### ELECTRICAL CHARACTERISTICS

#### INPUT VOLTAGE:

105-125 VAC or 210-250 VAC

47-63 Hz

#### OUTPUT VOLTAGE:

5vdc

#### OUTPUT CURRENT:

0-5 amps. short-circuit protected  
for parallel supply operation

#### OVERVOLTAGE PROTECTION:

The output is protected from transients which exceed 6.9 volts for more than 10 nsec. However, the output is not protected against long shorts to voltages above 6.9 volts.

### MECHANICAL CHARACTERISTICS

PANEL WIDTH: 19 in.

PANEL HEIGHT: 5 $\frac{3}{4}$  in.

DEPTH: 16 $\frac{3}{4}$  in.

FINISH: Chromicoat

POWER INPUT CONNECTIONS:

Screw terminals

Provided on transformer

MODULES ACCOMMODATED: 16

POWER OUTPUT CONNECTIONS:

Barrier strip with screw terminals and tabs which fit AMP "Faston" receptacle series 250, part no. 41774 or Type 914 power jumpers.

**1945-19 HOLD DOWN BAR:** Reduces vibration and keeps modules securely mounted when panel or system is moved. Adds  $\frac{1}{2}$  in. to depth of mounting panel.

H913—\$270

H914—\$125

## MODULAR PANEL HARDWARE

K950

**K**  
**SERIES**

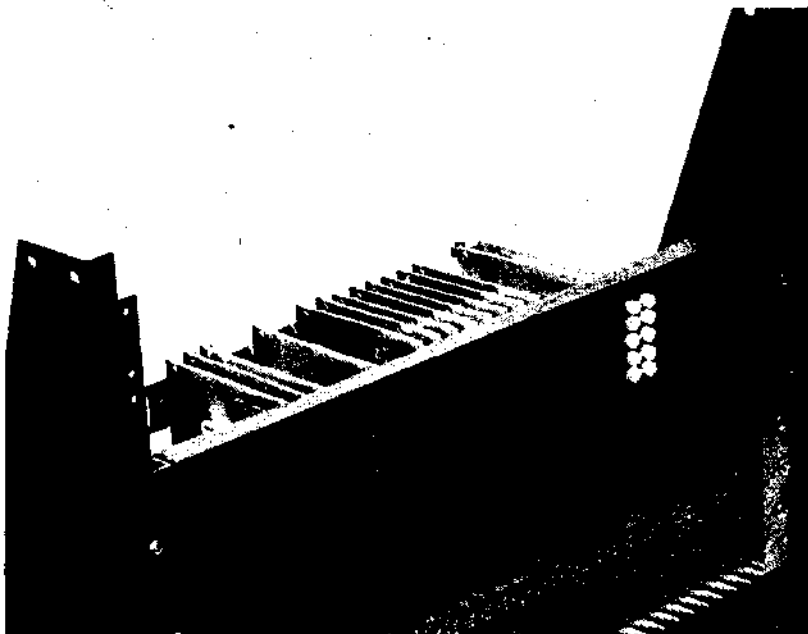

The K950 Magnetic modular panel hardware provides a convenient way to build control panels containing lights, toggle and push button switches, timer controls, and thumbwheel switches. The lower connector half of the control modules K410, K415, K420, K422, K424, and K432 are plugged into the upper connectors across a K943 mounting panel and the manual controls protrude through the K950 panel frame. The K410, K420, and K432 modules are supplied with a precut panel piece that fills the panel space for the module. The K422 and K424 modules do not require a panel piece. Since each module is covered independently of the next module, any module type can be plugged into any one of the available 32 panel socket locations. All panel hardware is supplied painted black, however, panel pieces may be individually repainted to give color coded meaning to panel controls. Thumbwheel modules are black plastic and can not be painted.

A control module can be inserted into any socket except the one directly to the left of a K422 or K424 thumbwheel module. For this reason it is recommended that all thumbwheel registers be grouped together in the same section of the panel to conserve panel locations. Metal spacers of single or double module width are available to cover unused panel locations.

---

K950—\$39

---

Another control module can not be mounted in the socket next to a K415 Nixie Display module. These modules can be mounted in every other socket location to form a neat multi-digit display.

The frame and panel pieces are made of steel and are held together with rivets and flexible strip magnets. The frame is mounted in a standard 19 inch rack directly above a socket mounting panel. After the control modules have been inserted into their chosen socket locations, the steel panel pieces are snapped into place to cover the modules and unused locations. After the panel is completely filled, a steel bezel is snapped into place over the panel pieces and the panel is complete.

The panel hardware can be disassembled at any time to allow controls to be added or removed.

When the panel is completely assembled, most of the magnetic lines of force are closed through the steel panel pieces. However, steel dust particles and filings will still be attracted to the panel surfaces. The magnetic force from the panel is not strong enough to damage a watch worn by the user. Each K950 is supplied with 8 single and 8 double spacers to cover up to 24 unused panel locations. The K950 is 3½ inches in height.

**END PLATES**  
K980

**HARDWARE**

Pair of plates for supporting 1907 cover to hold modules in K943 panel under shock and vibration. (Note: If vibration is anticipated, care must be taken not to nick logic wires. Use a quality wire stripping device.) Also used for mounting K741, K743, K782, K784.

---

K980—\$6

---

**COVER**  
1907

**HARDWARE**

Blue painted or brown tweed painted aluminum cover with captive screws to mate threaded bushings in K980 and H001. Adds to appearance while protecting system against vibration and tampering.

---

1907—\$9

---

## MOUNTING PANEL

K982

**K**  
**SERIES**

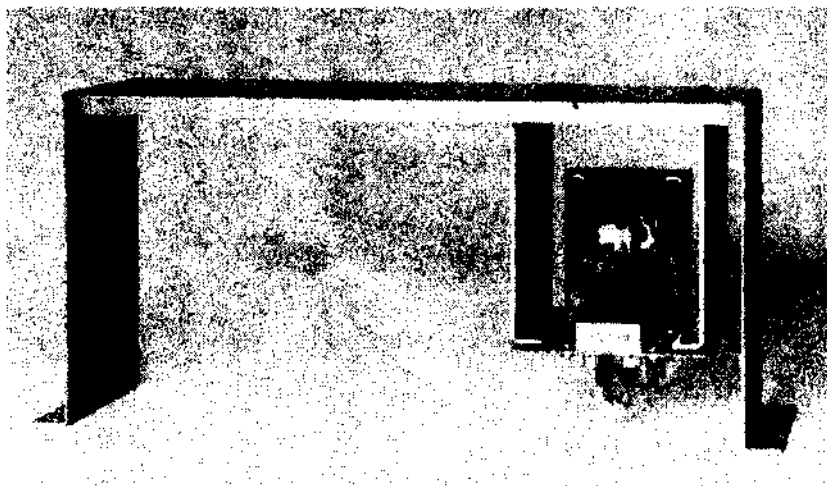

The K982 is a predrilled 19" mounting panel on which can be mounted up to three separate power transformers (K741 or K743).

Transformers can be mounted using either the K980 end brackets for exposed transformer connections or H002 setback brackets for unexposed transformer connections.

**K982—\$10**

# TIMER COMPONENT BOARD

K990

K  
SERIES

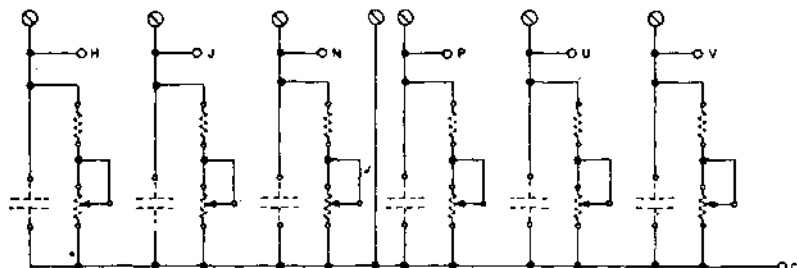

The K990 is a predrilled etched module for mounting up to six RC networks for K301, K303, or K323 timer controls. Any capacitor size up to a "D" case tantalum can be mounted in the space provided. A trimpot and series resistor can be mounted in the remaining space. Trimptot adjustments are accessible from the edge of the module. If the module is not mounted in the top row of modules in the system, a W980 extender module will be required to make trimptot adjustments. Etch layout is for trimptots with a staggered center pin. Connections to the module can be made either through the pins or through a cable soldered to split lugs.

Dimensions for trimptot mounting are:

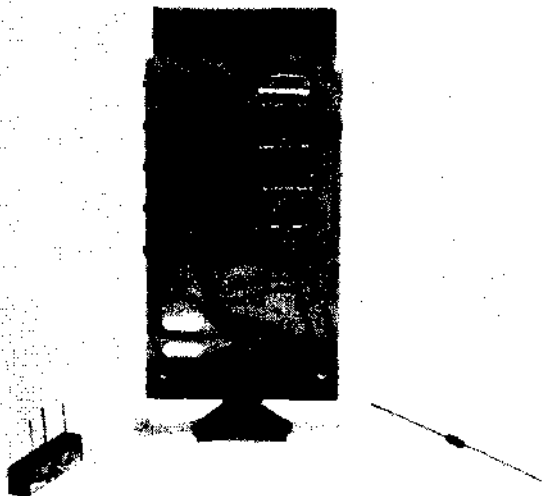

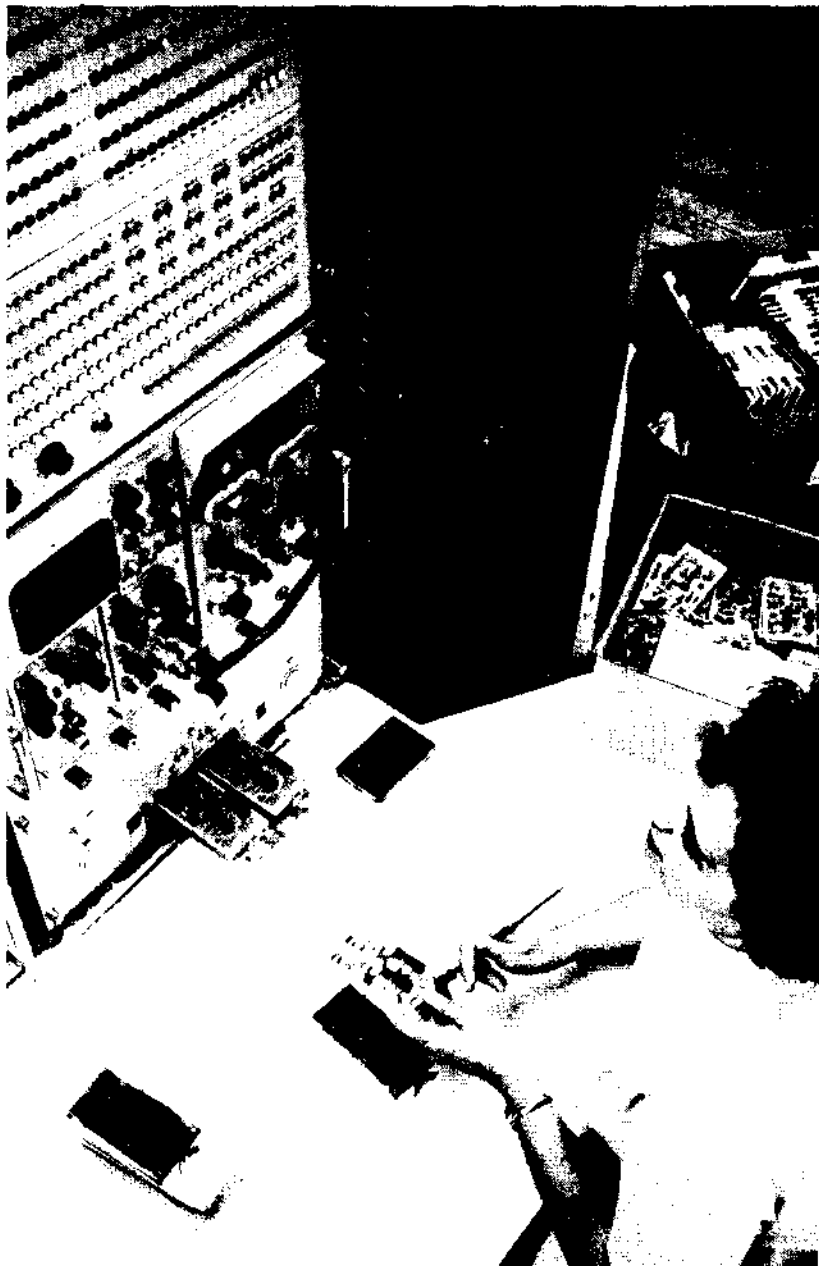

DEC thoroughly tests all finished modules as well as incoming components. Most of the testing is conducted on computerized equipment such as this one which performs 100 ac and dc tests in less than 5 seconds on each module tested.

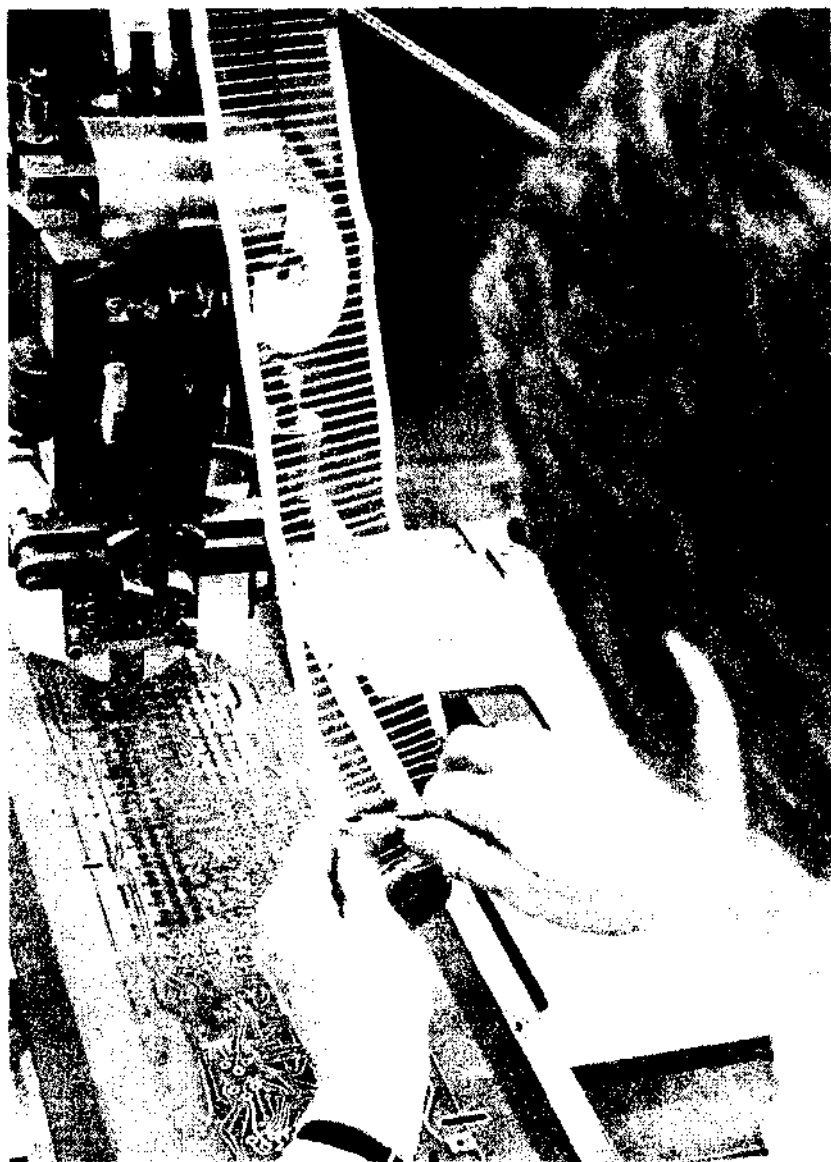

These pantograph-controlled insertion machines position and crimp pre-tested components onto four module boards at a time. A press will cut the modules apart after assembly is completed, minimizing handling up to that point.



# **A Series Analog Modules**

**POSITIVE LOGIC MULTIPLEXER**  
**TYPE A123**

**A**  
**SERIES**

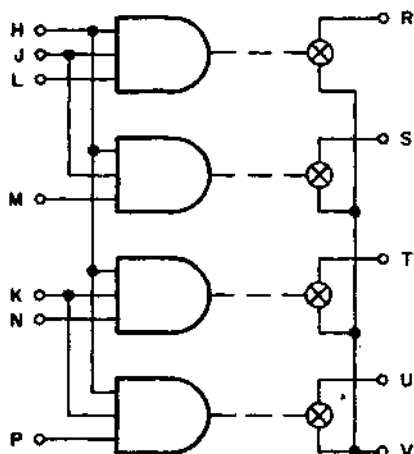

INPUT	OUTPUT TERMINALS
+3V	CONNECTED
0V	OPEN

The A123 Multiplexer provides 4 gated analog switches that are controlled by logic levels of 0v and +3v. The module is equivalent to a single-pole, 4-position switch, since one output terminal of each MOS FET switch is tied together. If all three digital inputs of a circuit are at +3v (or not connected) the two output terminals are connected together. If any digital input is at 0v, the switch terminals are disconnected. Two switches should not be on at the same time. The analog switch can handle signals between +10v and -10v, with currents up to 1 ma.

The positive power supply must be between +5v and +15v, and at least equal to or greater than the most positive excursion of the analog signal. The negative power supply must be between -5 and -20v, and at least 10 volts more negative than the most negative excursion of the analog signal. The voltage difference between the two supplies must not be more than 30v.

A123—\$58

## SPECIFICATIONS

### Digital Inputs

Logic ONE:	+2.4v to +5.0v
Logic ZERO:	0.0v to +0.8v
Input loading:	0.5 ma at 0 volts

### Analog Signal

Voltage range:	+10v to -10v
Current (max.):	1 ma

### Output Switch

On resistance, max.:	1000 ohms
On offset:	0 volts
Off leakage, capacitance:	10 na, 10 pf
Turn on delay, max.:	0.2 $\mu$ sec
Turn off delay, max.:	0.5 $\mu$ sec

### Power

+5v (pin A):	45 ma
+v (pin D):	18 ma (for +10v)
-v (pin E):	50 ma (for -20v)

# HIGH IMPEDANCE MULTIPLEXER EXPANDER A160

## A SERIES

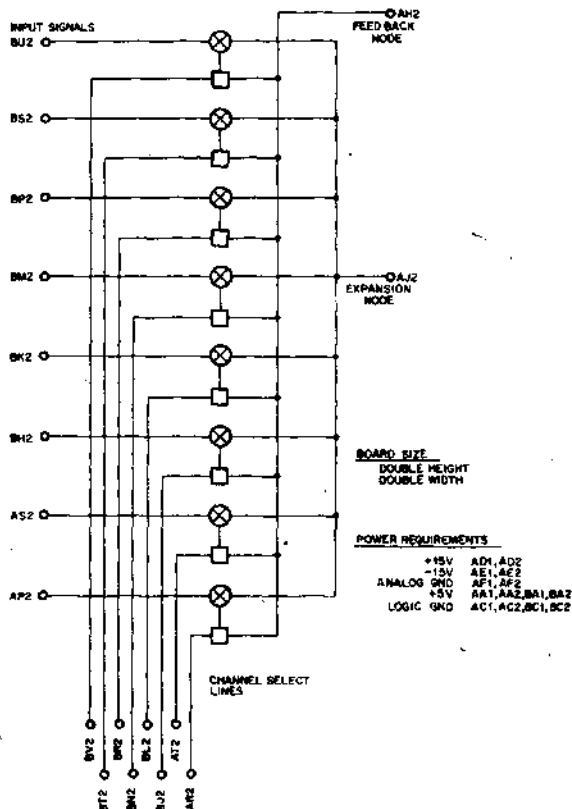

The A160 is a high impedance multiplexer expander consisting of 8 independent FET channels.

This unit may be used with any of the DEC high impedance multiplexers to perform single or double level multiplexing. It also may be used to expand the channel capabilities of the A162, A163, and A164, Multiplexer.

The A160 is DTL and TTL compatible and may be used with DEC's standard K and M Series logic modules. Each channel has its own channel selector driver and may be controlled from an external source such as a shift register, clock, or gating function.

**A160—\$250**

Advanced shielding techniques and optimized circuit layout have been employed in the A160, ensuring stable operation under normal ambient electrostatic and electromagnetic conditions, as well as allowing minimal cross-talk between channels.

### SPECIFICATIONS

Analog Inputs:	8 single ended
Input Voltage Range:	$\pm 10$ v. Maximum full scale
Expander Node:	Common point of 8 channels brought out to a common pin for input to external buffer amplifier
Feedback Input:	Feedback control point of multiplexer switches connected to output of buffer amplifier
Input Leakage:	0.5 nano ampere max., per channel
Input Feedthrough Capacity:	4 pf per channel
OFF Channel Capacity:	7 pf per channel, shunt capacity at common node
ON Resistance of Channel (Without Buffer):	1000 ohms max.
Max. Input Voltage	$\pm 15$ v.
Switching plus Settling Time:	5 $\mu$ sec., max., to settle to within .01% of full value for full scale excursion with zero source impedance
Output Range:	Same as input ( $\pm 10$ VFS)
Transfer Accuracy:	$\pm 0.01\%$ of full scale at 25° C.
Selector Input (Direct into Multiplexer):	One TTL Load
ON Level	Logic Zero (0 volts)
OFF Level	Logic One (+3 volts)

# HIGH IMPEDANCE MULTIPLEXER WITH OUTPUT BUFFER

## A161

# A SERIES

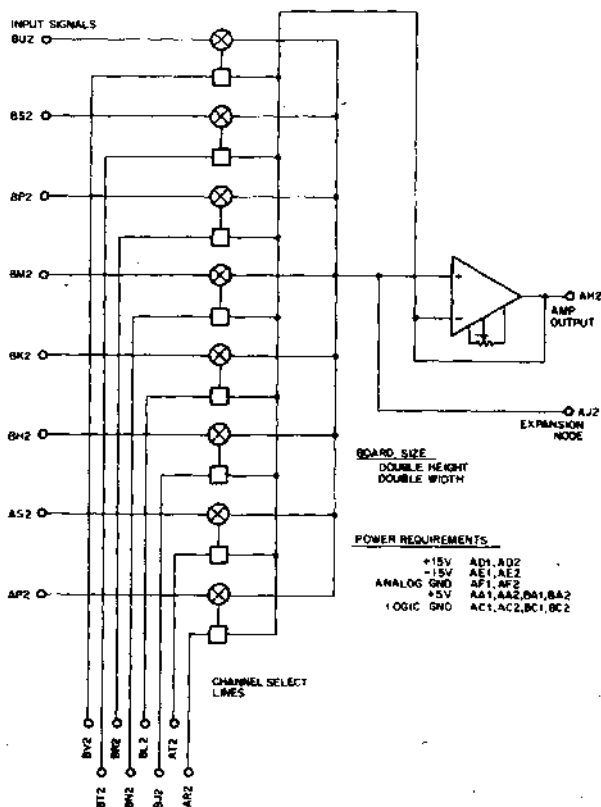

The A161 is a high impedance multiplexer consisting of 8 independent FET switched channels and a noninverting unity gain follower amplifier, designed for application where accuracy, high speed, and high input impedance are prime requirements.

This unit is DTL and TTL compatible and may be used with DEC K and M Series logic modules. It will also provide excellent performance with systems employing sample and holds, high speed multiplexing, D/A converters, as well as single and double level multiplexing.

Provided on the A161 are eight channel select lines, which may be controlled from an external source such as a shift register, clock, or gating function.

**A161—\$375**

The A161 has been engineered and factory adjusted to provide rated performance. It also employs advanced shielding techniques and optimized circuit layout, ensuring stable operation under normal ambient electrostatic and electromagnetic conditions, as well as allowing minimal crosstalk between channels.

The A161 has the capability of output channel expansion simply by typing in the A160 or A162 Multiplexer Expanders.

### SPECIFICATIONS

Analog inputs:	8 single ended
Input voltage range:	$\pm 10$ v. Maximum full scale
Expander node:	Common point of 8 channels brought out to pin as well as to input of buffer amplifier.
Input leakage:	0.5 nano ampere, max., per channel
Input feedthrough capacity:	4 pf per channel
OFF channel capacity:	7 pf per channel, shunt capacity at common node
Series ON resistance of channel:	1000 ohms max.
Shunt ON Resistance to ground:	10 ohms min.
Switching plus settling time:	5 $\mu$ sec., max., to settle to within .01% of final value for full scale excursion with zero source impedance
Fault protection:	Current limiting to 10 ma. provided
Max. Input Voltage (Without Damage):	$\pm 15$ v.
Output Range:	Same as input ( $\pm 10$ VFS)
Output Current:	$\pm 20$ ma., maximum
Output Protection:	Short circuit protection, indefinitely to ground
Amplifier Offset:	Adjustable to zero
Transfer Accuracy:	$\pm 0.01\%$ of full scale at 25° C.
Temp. Coefficient:	30 $\mu$ v/° C.
Selection Inputs (Direct into Multiplexer):	One TTL Load
ON Level:	Logic Zero
OFF Level:	Logic One
Power Requirements:	$\pm 15$ v. at 35 ma.

# HIGH IMPEDANCE MULTIPLEXER WITH DECODER

## A162

# A SERIES

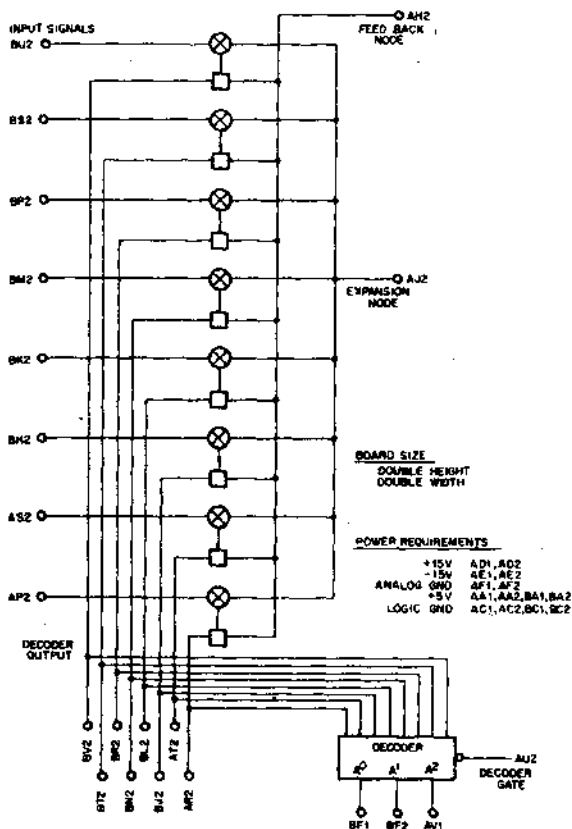

The A162 is a high impedance multiplexer with decoder consisting of 8 independent FET switched channels. Included on this module is a gated binary to octal decoder for selecting any of the eight high speed channels.

The A162 may be used as a stand-alone multiplexer or with any of the high impedance multiplexers to perform single or double level multiplexing. It also may be used as an expander to increase the channel capabilities of the A163 or A164, Multiplexers.

This unit has been engineered and factory adjusted to provide rated performance, and is fully compatible with DTL and TTL systems.

**A162—\$270**



The A162 employs advanced shielding techniques and optimized circuit layout, ensuring stable operation under normal ambient electrostatic and electromagnetic conditions, as well as allowing minimal crosstalk between channels.

### SPECIFICATIONS

Analog Inputs:	8 Single Ended
Input Voltage Range:	$\pm 10$ v. Maximum full scale
Expander Node:	Common point of 8 channels brought out to a common pin for connection to the input of the external buffer amp.
Feedback Input:	Feedback control point of multiplexer switches connected to output of buffer amplifier.
Input Leakage:	0.5 nano ampere, max., per channel
Input Feedthrough Capacity:	4 pf per channel
OFF Channel Capacity:	7 pf per channel, shunt capacity at common node
ON Resistance of Channel (Without Buffer):	1000 ohms max.
Switching Plus Settling Time:	5 $\mu$ sec., max., to settle to within .01% of final value for full scale excursion with zero source impedance

#### Decoder

Decoder:	One of 8 lines, decoded, binary
Decoder Outputs:	Select: Logic zero De-select: Logic one
Decoder Inputs—	
A0 IN to A2 IN:	Address Lines One TTL Load High = One
Decoder Gate Input:	Logic zero enables decoder out
Fault Protection:	Current limiting to 10 ma provided
Max. Input Voltage (Without DaDmage):	$\pm 15$ v.
Output Range:	Same as input ( $\pm 10$ VFS)
Power Requirements:	$\pm 15$ v. at 35 ma. +5 v. at 30 ma. (with decoder option)

# HIGH IMPEDANCE MULTIPLEXER WITH DECODER AND BUFFER

A163

A  
SERIES

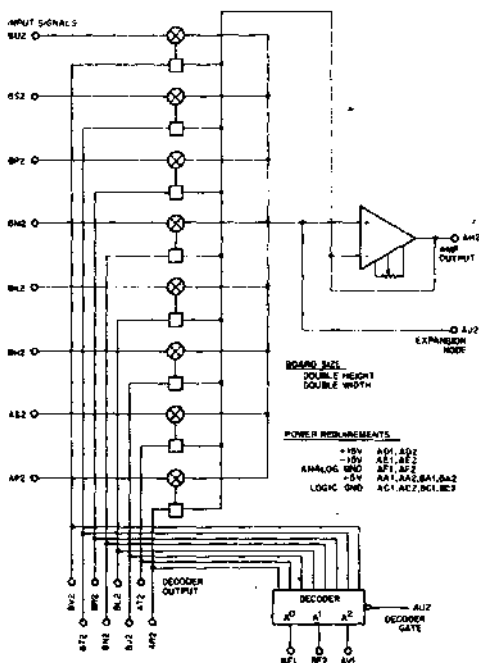

The A163 is a high impedance multiplexer consisting of 8 FET switched channels, a noninverting unity gain follower amplifier, and an 8 bit binary to octal decoder for channel selecting.

This unit was designed for application where accuracy, speed, and high input impedance are important factors. It also may be used in systems which employ sample and holds, D/A converters, and high speed multiplexing.

Provided on the A163 is an expansion node, which when used in conjunction with either of the high impedance multiplexer expanders (A160, A162) will provide additional input channels.

The A163 is fully compatible with DTL and TTL logic levels and may be used with DEC's standard K and M Series digital logic modules.

This module has been engineered and factory adjusted to provide proper operation over the specified range.

Optimized circuit layout has been employed in the packaging of the A163 ensuring minimal crosstalk between channels. Advanced shielding techniques

A163—\$395

of the switching circuitry have been used to allow proper operation under normal ambient electrostatic and electromagnetic conditions.

### SPECIFICATION

No. of Inputs:	8 Single Ended
Input Voltage Range:	$\pm 10$ v. maximum full scale
Expander Node:	Common point of 8 channels brought out to pin as well as to input of buffer amplifier
Input Leakage:	0.5 nano ampere, max., per channel
Input Feedthrough Capacity:	4 pf per channel
OFF Channel Capacity:	7 pf per channel, shunt capacity at common node
ON Resistance of Channel (Without Buffer):	1000 ohms max.
Switching Plus Settling Time:	5 $\mu$ sec, max. to settle to within .01% of final value for full scale excursion with zero source impedance
Fault Protection:	Current limiting to 10 ma provided
Max. Input Voltage (Without Damage):	$\pm 15$ v.
Output Range:	Same as Input ( $\pm 10$ VFS)
Output Current:	$\pm 20$ ma, max.
Output Protection:	Short circuit protection, indefinitely to ground
Amplifier Offset:	Adjustable to zero
Transfer Accuracy:	$\pm 0.01\%$ of full scale at 25° C.
Temp. Coefficient:	30 $\mu$ v/° C.
<b>Decoder</b>	
Decoder:	One of 8 lines, decoded, binary
Decoder Outputs:	Select: Logic zero De-select: Logic one
Decoder Inputs—	
A0 IN to A2 IN:	Address Lines One TTL Load High = One
Decoder Gate Input:	Logic zero enables decoder out
Power Requirements:	$\pm 15$ v. at 35 ma. $+5$ v. at 30 ma (with decoder option)
Size:	One Double Height Double Width Module

# EIGHT CHANNEL CONSTANT IMPEDANCE MULTIPLEXER EXPANDER

## A164

# A SERIES

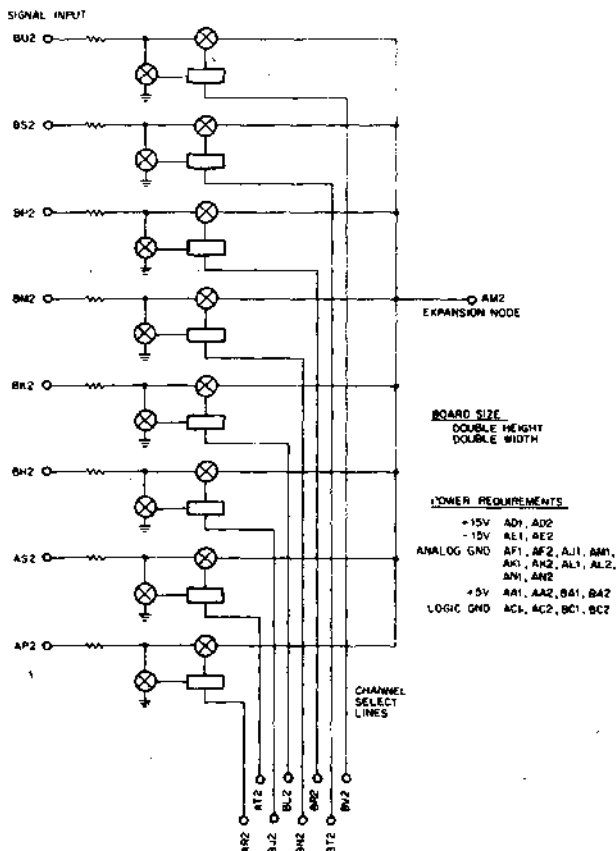

The A164 is an 8 channel constant impedance multiplexer expander utilizing eight FETS to switch the input signal through eight precision resistors either to ground (OFF) or to a virtual ground null point of an operational amplifier (ON).

This unit is used primarily with the A165, A166, and the A167 as a means of providing additional input channels. It may also be used to do high voltage multiplexing and input scaling.

A164—\$350

The A164 does not contain an output amplifier; therefore, to ensure proper operation, the output must be terminated into a buffer amplifier whose gain is equal to minus one. The A164 or the A165 may be used to accomplish this if the A164 is being used as an expander to either of these modules. If used as a stand alone module, the A260 dual amplifier card may be used as a buffer amplifier.

Provided on the A164 are eight channel select lines. These lines are brought to pin connections and may be controlled from an external source such as a shift register, clock, or gating functions.

#### SPECIFICATIONS

Number of Inputs:	8
Input Impedance:	10,000 ohms
Input Range:	$\pm 10$ volts
Switching Plus Settling Time:	5 $\mu$ sec to .01%
Expander Node:	Summing point brought to pin to allow expansion of number of channels.
Switch Leakage:	0.5 nano amp per "OFF" channel
Feedthrough (all channels OFF & 20 Vp-p at inputs):	-86 db at 1 KHz (Ratio = 20,000: 1)
Select Lines (1 TTL Load)---	
"ON":	Logic Zero
"OFF":	Logic One
Power Requirements:	$\pm 15$ v. at 40 ma.
Size:	One double height, double width

# CONSTANT IMPEDANCE MULTIPLEXER WITH OUTPUT AMPLIFIER

A165

**A  
SERIES**

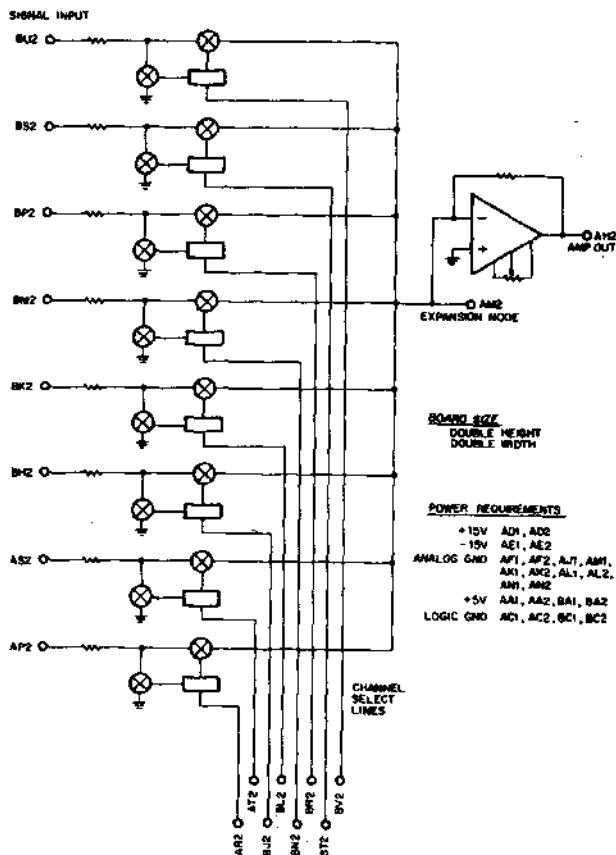

The A165 is a constant impedance multiplexer consisting of eight independent channels which utilize FETs to switch the input signal through precision resistors into either a ground (OFF) or a virtual ground of an operational amplifier (on).

Included on this module is the operational amplifier, which has been factory adjusted to yield a gain of minus one. Also included on the A165 are eight channel select lines which may be controlled from an external source, such as a shift register, clock, or gating functions.

A165—\$475

The A165 is DTL and TTL compatible and may be used with DEC's standard "K" and "M" Series modules to perform control functions.

The A165 may also be used in the multiplexing of high voltage or input scaling. It also may be used in conjunction with other constant impedance multiplexers.

DEC's constant impedance multiplexers have been engineered and packaged using optimized circuit layouts to ensure minimal crosstalk between channels. Advanced shielding techniques allow stable operation under normal ambient electrostatic and electromagnetic conditions.

### SPECIFICATIONS

Number of Inputs:	8
Input Impedance:	10,000 ohms
Input Range:	$\pm 10$ volts
Output Range:	$\pm 10$ volts, inverted with respect to input.
Output Drive:	20 ma.
Switching Plus Settling Time:	5 $\mu$ sec to .01%
Expander Node:	Summing point brought to pin to allow expansion of number of channels.
Switch Leakage:	0.5 nano amp per "OFF" channel
Transfer Ratio:	Minus one for 10v range
Transfer Accuracy:	$\pm 0.015\%$ of full scale
Temp. Coefficient of Offset:	50 $\mu$ v/degrees C.
Temp. Coefficient of Gain:	7 PPM/degrees C.
Feedthrough (all channels OFF & 20 Vp-p at inputs):	-86db at 1 KHz (Ratio 20,000 :: 1)
Select Lines (1 TTL Load)—	
"ON":	Logic Zero
"OFF":	Logic One
Power Requirements:	$\pm 15$ v. at 40 ma.
Size:	One double height, double width card

# CONSTANT IMPEDANCE EXPANDER MULTIPLEXER WITH DECODER

A166

**A  
SERIES**

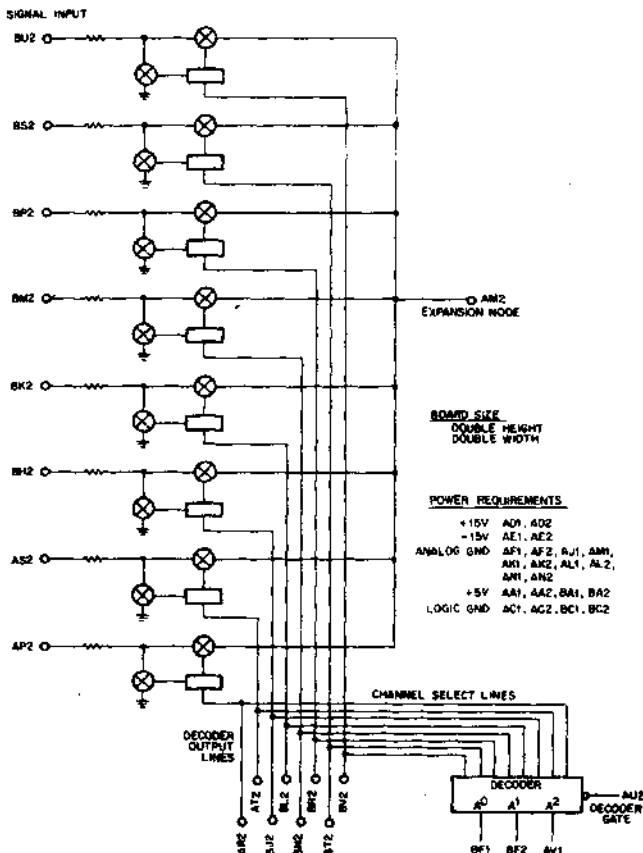

The A166 is a constant impedance eight channel multiplexer with decoder.

This unit can be used for multiplexing high voltage signals, single level or double level multiplexing, input scaling, or as a means to expand the channel capabilities of either the A155 or A167 DEC multiplexer.

Contained on the A166 as a binary to octal decoder which can be used to select either randomly or in sequence any of the eight analog input channels.

If the A166 is to be used as a stand alone multiplexer, its output must terminate into the null point of a buffer amplifier whose feedback resistor is 10,000 ohms.

**A166—\$365**



## SPECIFICATIONS

Number of Inputs:	8
Input Impedance:	10,000 ohms
Input Range:	$\pm 10$ volts
Switching Plus Settling Time with output amp	5 $\mu$ sec to .01%
Expander Node:	Summing point brought to pin to allow expansion of number of channels.
Switch Leakage:	0.5 nano amp per "OFF" channel
Transfer Accuracy:	$\pm 0.015\%$ of full scale
Feedthrough (all channels OFF & 20 Vp-p at inputs):	$\approx 86$ db at 1 KHz (Ratio 20,000: 1)

### Decoder

Decoder:	One of 8 lines decoded, binary
Decoder Outputs:	9 TTL Loads Select = Logic Zero Deselect = Logic One
Select Lines (1 TTL Load)—	
"ON":	Logic Zero
"OFF":	Logic One

### Decoder

Decoder:	One of eight lines decoded, binary
Decoder Outputs:	9 TTL Loads Select = Logic Zero Deselect = Logic One
Decoder Inputs—	
A0 IN to A2 IN:	Address Lines—3 bit binary code One TTL Load Positive voltage = Logic One
Decoder Gate:	One TTL Load Logic One yields disable Logic Zero yields enable
Power Requirements:	$\pm 15$ v. at 40 ma. $\pm 5$ v. at 30 ma. (with decoder option)
Size:	One double height double width module

# CONSTANT IMPEDANCE MULTIPLEXER WITH DECODER AND OUTPUT AMP

## A167

# A SERIES

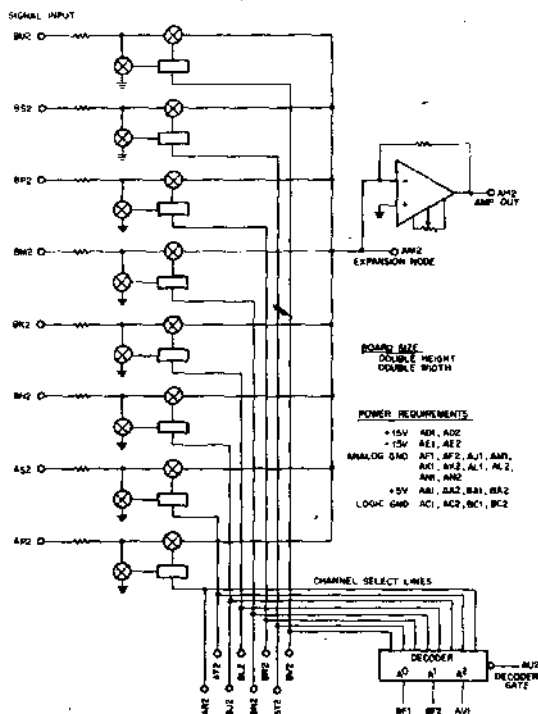

The A167 is an eight channel constant impedance multiplexer with output amplifier and decoder. The operation of the A167 is performed in the same manner as any of the other DEC constant impedance multiplexers, where the input signal is switched via FETs to either ground (OFF) or into a virtual ground null point (ON) of the operational amplifier.

This unit may be used for multiplexing of high voltages, input scaling, and in situations that require single or double level multiplexing.

The A167 has the capability of being expanded by any of the constant impedance multiplexers (A166, A164). The limitation to the number of channel expansions will depend upon system specifications, speed, leakage current of OFF channels, and the output drive capabilities of the source.

The output amplifier has been factory adjusted and preset to a gain of minus one. The decoder is an eight bit binary to octal decoder with gating facilities on the decoder to control its states.

A167—\$490

Advanced shielding and layout techniques have been employed on the A167 to allow stable operation under normal ambient electrostatic and electromagnetic conditions as well as minimal crosstalk between channels.

### SPECIFICATIONS

Number of Inputs:	Eight
Input Impedance:	10,000 ohms
Input Range:	$\pm 10$ volts
Output Range:	$\pm 10$ volts
Output Drive:	20 ma.
Switching Plus Settling Time:	5 $\mu$ sec to .01%
Expander Node:	Summing point brought to pin to allow expansion of number of channels.
Switch Leakage:	0.5 nano amp per "OFF" channel
Transfer Ratio:	Minus one for 10v range
Transfer Accuracy:	$\pm 0.015\%$ of full scale
Temp. Coefficient of Offset:	50 $\mu$ v/degrees C.
Temp. Coefficient of Gain:	7 PPM/degrees C.
Feedthrough (all channels OFF & 20Vp-p at inputs):	-86db at 1 KHz (Ratio 20,000 : 1)
Select Lines (1 TTL Load)—	
"ON":	Logic Zero
"OFF":	Logic One
<b>Decoder</b>	
Decoder:	One of eight lines decoded, binary
Decoder Outputs:	9 TTL Loads Select = Logic Zero Deselect = Logic One
Decoder Inputs—	
A0 IN to A2 IN:	Address Lines—3 bit binary code One TTL Load Positive voltage = Logic One
Decoder Gate:	One TTL Load Logic One yields disable Logic Zero yields enable
Power Requirements:	$\pm 15$ v. at 40 ma. $\pm 5$ v. at 30 ma. (with decoder option)
Size:	One Double Height Double Width Module

# OPERATIONAL AMPLIFIER

## A207

# A SERIES

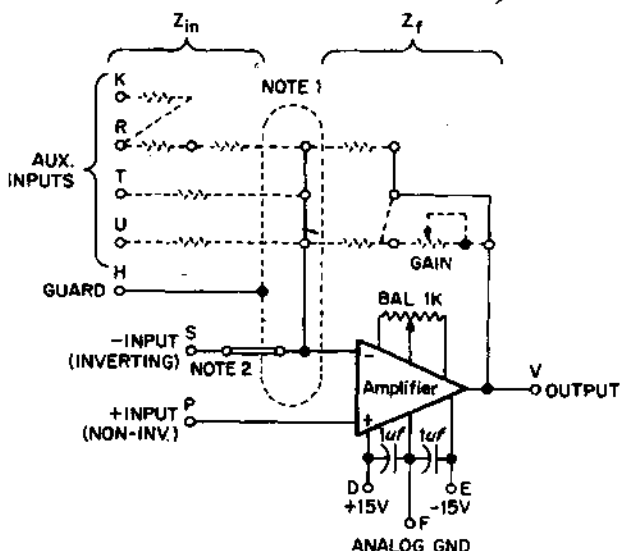

**NOTE 1.** Mounting holes are provided on the module so that input and feedback components can be added. Components shown with dashed lines are not included with the module.

**NOTE 2.** This jumper comes with the module. It may be removed to suit circuit requirements.

**NOTE 3.** Pins L & M can be connected together to improve settling time, but parameters such as drift and open loop gain are degraded.

The A207 is an economical Operational Amplifier featuring fast settling time (5  $\mu$ s to within 10 mv), making it especially suited for use with Analog-to-Digital Converters. The A207 can be used for buffering, scale-changing, off-setting, and other data-conditioning functions required with A/D Converters. All other normal operational amplifier configurations can be achieved with the A207.

The A207 is supplied with a zero balance potentiometer. Provisions are made on the board for the mounting of input and feedback components, including a gain trim potentiometer. The A207 is pin-compatible with the A200 Operational Amplifier.

A207—\$45

**SPECIFICATIONS**—At 25°C, unless noted otherwise.

	<b>Pins L &amp; M Differences with Pins</b>
	<b>Connected L &amp; M Not Connected</b>

**Settling Time\***

Within 10 mv, 10v step input, typ:	3 $\mu$ sec	6 $\mu$ sec
Within 10 mv, 10v step input, max:	5 $\mu$ sec	8 $\mu$ sec
Within 1 mv, 10v step input, max:	7 $\mu$ sec	10 $\mu$ sec

**Frequency Response**

Dc open loop gain, 670 ohm load, min:	15,000	100,000
Unity gain, small signal, min:	3 MHz	
Full output voltage, min:	50 KHz	
Slewing rate, min:	3.5v/ $\mu$ sec	
Overload recovery, max:	8 $\mu$ sec	

**Output**

Voltage, max:	$\pm$ 10v
Current, max:	$\pm$ 15 ma

**Input Voltage**

Input voltage range, max:	+10v
Differential voltage, max:	$\pm$ 10v
Common mode rejection, min:	10,000

**Input Impedance**

Between inputs, min:	100 K ohms
Common mode, min:	5 M ohms

**Input Offset**

Avg. voltage drift vs. temp, max:	60 $\mu$ v/ $^{\circ}$ C	30 $\mu$ v/ $^{\circ}$ C
Initial current offset, max:	0.5 $\mu$ a	
Avg. current drift vs. temp, max:	5 na/ $^{\circ}$ C	

**Temperature Range**

0°C to +60°C

**Power**

+15v (pin D), quiescent:	6 ma
-15v (pin E), quiescent:	10 ma

If the Output is accidentally shorted to ground, the amplifier will not be damaged.

\*Gain of 1, inverting or non-inverting configuration.

# DUAL AMPLIFIER CARD

## A260

# A SERIES

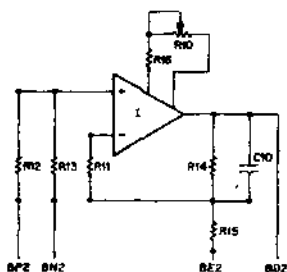

BOARD SIZE.  
DOUBLE HEIGHT  
DOUBLE WIDTH

POWER REQUIREMENTS  
+15V → AD2  
-15V → AE2  
ANALOG GND → AF2

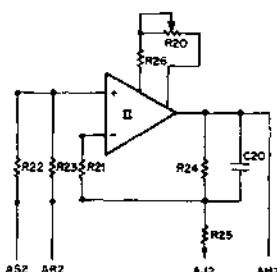

The A260 is a universal dual amplifier card which contains two independent operational amplifiers. Provisions have been made for mounting input and feedback components so that the A260 may be used in a variety of modes.

Some of the configurations in which the A260 may be used are:

1. Voltage follower with a gain of plus one.
2. Voltage follower with positive gain of greater than one.
3. Attenuated follower with positive gain of less than one.
4. Differential amplifier with differential input and single ended output.
5. Inverter with negative gain of one or greater.

The A260 may also be used as the output buffer for the A160 and A164 multiplexer series, as well as the input buffer for the A400 series sample and hold modules. Individual offset adjustments are provided for on each amplifier.

A260—\$300

## SPECIFICATIONS

**Description:** Two differential amplifiers mounted on one board with provision for mounting resistors in a variety of modes.

**Offset:** Adjustments provided to adjust offset to zero.

### Configurations

**A. Follower** High input impedance, gain of plus one.

**Transfer Accuracy:**  $\pm 0.01\%$  of FS

**Settling Time (0 to 10v):** 1.5  $\mu$ s to .01%

**Output drive:** 20 ma., short circuit proof to ground.

**Input/output range:**  $\pm 10$  volts

**Input impedance:** 1000 megohms

**Temp. Coefficient:** 30  $\mu$ v/ $^{\circ}$ C.

**B. Follower with Gain—** High input impedance, positive gain greater than one.

**Transfer accuracy:** Function of resistors provided.

**Gain:** Determined by  $\frac{R14 + R15}{R15}$

**Settling Time:** (Gain) x (1.5  $\mu$ s) to .01%

**Output Drive:** 20 ma. short circuit proof to ground.

**Input/Output range:**  $\pm 10$  volts

**Input Impedance:**  $\geq 100$  megohms

**Temp. Coefficient:** 30  $\mu$ v/ $^{\circ}$ C. (referred to input)

**C. Attenuated follower—** Input attenuator, positive gain less than one.

**Gain:**  $\frac{R13}{R12 + R13}$  (see schematic)

**Transfer Accuracy:** Function of resistors provided.

**Settling Time:** 1.5  $\mu$ s to .01% if not limited by attenuator.

**Input Range:** 0 to  $\pm 100$  volts, max.

**Output Range:** + 10 volts

Output Drive:	20 ma., short circuit proof to ground.
Input Impedance:	$R_{12} + R_{13}$
Temp. Coefficient:	$30 \mu\text{V}/^\circ\text{C}$ . plus input attenuation.
<b>D. Differential Amplifier:</b>	Differential input, single ended output.
Gain:	$\frac{R_{14}}{R_{15}}$
Transfer Accuracy:	Function of resistors provided.
Settling Time:	$(\text{Gain}) \times (1.5\mu\text{s})$
Input Voltage (Signal plus common mode):	$(1 + \frac{1}{\text{Gain}}) \times (10\text{V})$ max.
Output Range:	$\pm 10$ volts
Output Drive:	20 ma., short circuit proof to ground.
Temp. Coefficient:	$(30 \mu\text{V}/^\circ\text{C}) \times (1 + \text{Gain})$
Common Mode Rejection:	Function of resistor matching in each input $> 86$ db for .01% resistor match in addition to transfer accuracy of .01%
<b>E. Inverter</b>	Negative gain of one or greater
Specs same as differential amplifier, except input referenced to ground.	
<b>F. Power</b>	
+15v @ 20ma	
-15v @ 15ma	



1. FOLLOWER

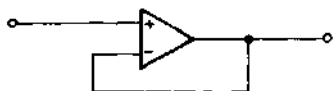

2. PLUS GAIN

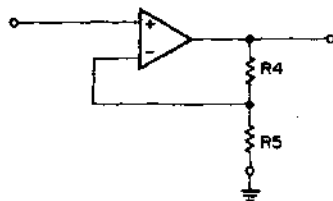

$$\frac{E_O}{E_{IN}} = \frac{R_4 + R_5}{R_5}$$

3. POSITIVE GAIN LESS THEN ONE

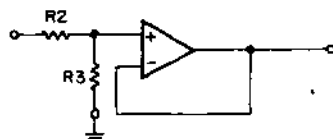

$$\frac{E_O}{E_{IN}} = \frac{R_3}{R_3 + R_2}$$

4. DIFF. INPUT

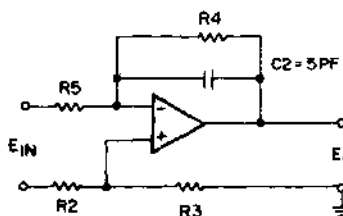

$$\frac{E_O}{E_{IN}} = \frac{R_4}{R_5}$$

5. INVERTER

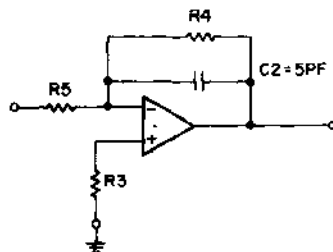

$$\frac{E_O}{E_{IN}} = \frac{R_3}{R_4}$$

R12 R22	R13 R23	R14 R24	R15 R25
0Ω	∞	0	∞
0Ω	∞	5K G =	5K +2
		9K G =	1K +10
50K G =	50K +1/2	0	∞
20K	20K G =	20K 1	20K
∞	10K G =	20K -1	20K

# SAMPLE AND HOLD

A404

A  
SERIES

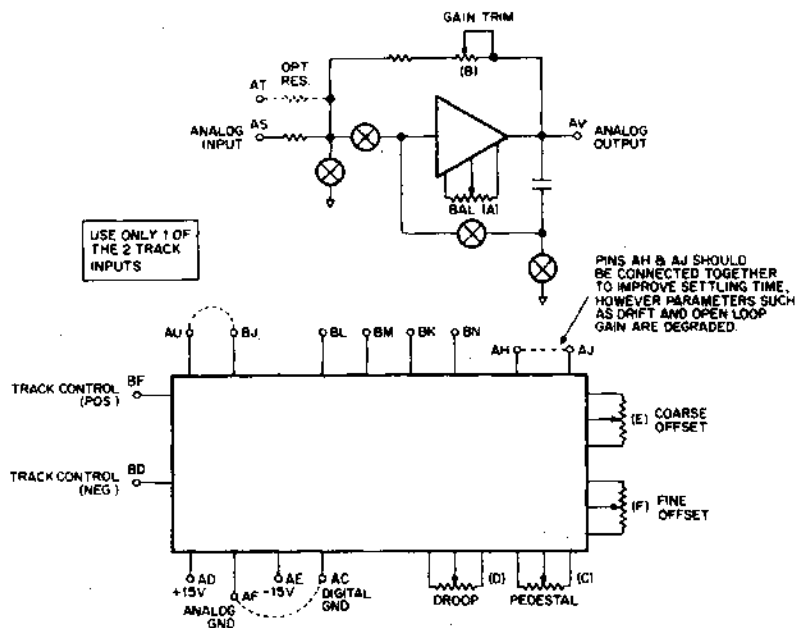

## JUMPER CONNECTIONS TO OFFSET OUTPUT

MODE			Positive	Negative
PIN	TRACK	(sample) HOLD		
BF (pos)	+3v or open	0v	AU to BJ	AU to BJ
BD (neg)	-3v or open	0v	BM to AE	BL to AD
			BK to AF	BN to AF

Analog gnd (pin AF) and digital gnd (pin AC) must be connected together at one point in the system.

The A404 Sample & Hold has an acquisition time of 6  $\mu$ sec for a 10 volt signal to within 10 mv (0.1%). The circuit inverts the input signal, and has an input impedance to 10 K. Features of the circuit include potentiometers to control the pedestal and the droop of the output signal.

A404—\$130

Two digital Track Control (sample) inputs are provided: one for negative logic (0v & -3v), and the other for positive logic (0v & +3v). Either input by itself will perform the necessary control, and the inadvertent application of both digital signals will cause no damage to the circuit.

Potentiometers are also provided for zero balancing, gain trim, and offset adjustment (up to  $\pm 10v$ ). If offsetting is desired, connections should be made according to the table shown with the diagram. The A404 is pin-compatible with the A400 Sample & Hold.

**SPECIFICATIONS**—At 25°C, unless noted otherwise. Pins AH & AJ are connected together.

**Acquisition Time**

Within 10 mv, 10v step input, typ:	4 $\mu$ sec
Within 10 mv, 10v step input, max:	6 $\mu$ sec
Within 2.5 mv, 10v step input, max:	11 $\mu$ sec

**Aperture Time, max:** 0.2  $\mu$ sec

**Gain** -1.000 (adjustable  $\pm 0.2\%$ )

**Input**

Voltage range, max:	$\pm 10v$
Impedance:	10 K ohms

**Output**

Voltage range, max:	$\pm 10v$
Current, max:	10 ma

**Pedestal\***

Initial pedestal:	Adjustable to less than 1 mv
Pedestal variation vs. temp, max:	0.2 mv/°C

**Droop**

Initial droop:	Adjustable to less than 5 mv/ms
Droop variation vs. temp, max:	2 mv/ms/°C

**Track Control**

Pos. (pin BF)	+3v, Track 0v at 2 ma, Hold
Neg. (pin BD)	-3v, Track 0v at 1 ma, Hold

**Board Size** 1 double height board, single module width

**Temperature Range** 0°C to +50°C

**Power**

+15v (pin AD), quiescent:	22 ma
-15v (pin AE), quiescent:	35 ma

If the Output is accidentally shorted to Ground, the circuit will not be damaged.

\*Difference in output voltage when changing from Track to Hold mode.

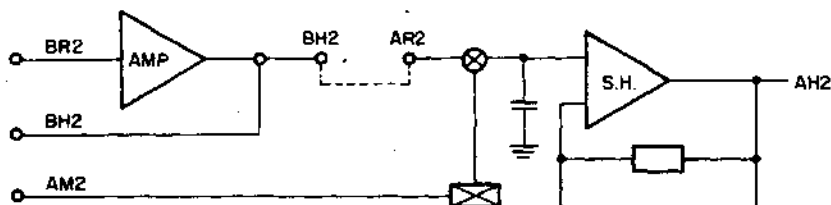
**SAMPLE AND HOLD****A460/A461****A  
SERIES****POWER REQUIREMENTS:**

-15V AE2  
+15V AD2  
ANALOG GND AF2

**BOARD SIZE:**

DOUBLE HEIGHT  
DOUBLE WIDTH

The A460 and A461 are one channel sample and hold modules used to sample the value of a changing analog signal at a particular point in time and store this information.

The difference between the A460 and the A461 is that the A460 is a S/H without input buffering and the A461 is S/H with input buffering. It should be noted that when using the A461 an external jumper is required between pins BH2 and AR2.

Provided on the A460 and A461 is a select line which can be used to control the sample or hold operation of the module.

Both the A460 and A461 are DTL and TTL compatible and may be used with standard "M" or "K" Series modules in control and system configurations.

The output circuitry consists of a buffer amplifier with output drive capability of 20 ma. Both the A460 and A461 are compatible with DEC "A" Series high impedance and constant impedance multiplexers and may be used in conjunction with each to perform various levels of multiplexing.

---

A460—\$400  
A461—\$525

---

## SPECIFICATIONS

Transfer Accuracy at 23° C.	±0.01% FS
Input/Output Voltage Range	±10V Full Scale
Transfer Characteristic	+1
Acquisition Time (to 0.01%)	5 microseconds for -10V to +10V excursion
Aperture Time	Less than 50 nanoseconds
Input Impedance (During Sample Time)— (With No Buffer):	100 ohms in series with 0.002 microfarad capacitor
	34
(With Buffer):	1000 meg ohms in parallel with 10 pf.
Output Drive:	20 ma.
Hold Decay:	15 microvolts per millisecond
Offset:	Adjustable to zero
Temp. Coefficient of Offset:	50 $\mu\text{V}/^\circ\text{C}$ .
Control Input (1 TTL Load)— Sample:	Logic Zero
Hold:	Logic One
Power:	±15V at 12 ma w/o buffer ±15V at 20 ma with buffer
Size:	One double height double width module.

# 12-BIT DAC

## A613

# A SERIES

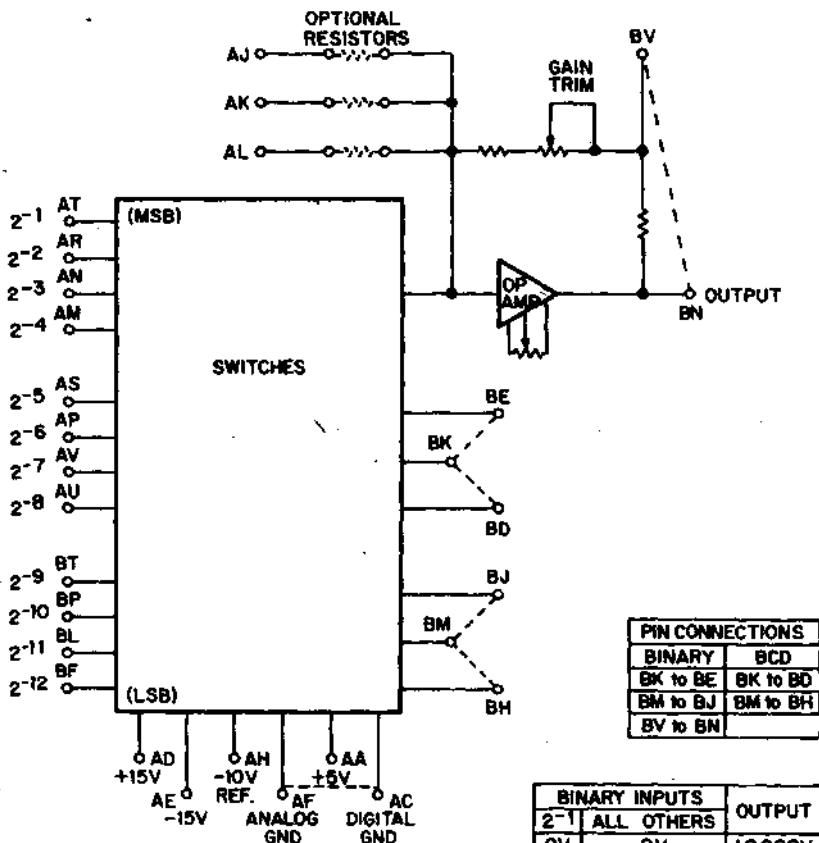

PIN CONNECTIONS	
BINARY	BCD
BK to BE	BK to BD
BM to BJ	BM to BH
BV to BN	

BINARY INPUTS		OUTPUT
2-1	ALL OTHERS	
0V	0V	+0.000V
+3	0	+5.000
+3	+3	+9.9975

ANALOG GND (PIN AF) & DIGITAL GND (PIN AC) MUST BE CONNECTED TOGETHER AT ONE POINT IN THE SYSTEM.

The A613 is a 12-bit Digital-to-Analog Converter for moderate speed applications. The module is controlled by standard positive logic levels, has an output between 0v and +10v, and will settle within 50  $\mu$ sec for a full scale input change. The input coding can be either straight binary or 3 decades of 8421 BCD with only simple connector jumpers required to take care of the change.

A613—\$200

The A613 requires a  $-10.0\text{v}$  reference that can supply negative current, such as an A704. Provisions are made for adding up to 3 extra resistors to implement offsetting functions. Potentiometers are provided for zero balancing, and gain trim. The A613 is a double height board.

An input of all Logic 0's produces zero volts out; all Logic 1's produces close to  $+10\text{v}$  out. The operational amplifier output can be shorted to Ground without damaging the circuit.

### SPECIFICATIONS

#### Inputs

Logic ONE:	$+2.0\text{v}$ to $+5.0\text{v}$
Logic ZERO:	$0.0\text{v}$ to $+0.8\text{v}$
Input loading:	1 ma (max.) at 0 volts

#### Output

Standard:	$0\text{v}$ to $+10\text{v}$
Optional, (requires Positive REF)	10v range between $-10\text{v}$ and $+10\text{v}$
Settling time, (10v step):	50 $\mu\text{sec}$
Output current:	10 ma
Capacitive loading:	0.1 $\mu\text{f}$ (without oscillation)

Binary Dig. In.	Analog Out	BCD (8421)	Analog Out
000 — 00	0.0000v	000	0.000v
000 — 01	$+0.0025$	001	$+0.010$
001 — 00	$+5.0000$	050	$+0.500$
111 — 11	$+9.9975$	500	$+5.000$
		999	$+9.990$

#### Accuracy

	Binary	BCD
At $+25^{\circ}\text{C}$ :	$\pm 0.015\%$ of full scale	$\pm 0.05\%$ of full scale
Temp. coef:	$\pm 0.001\%/^{\circ}\text{C}$ (plus drift of REF)	$\pm 0.002\%/^{\circ}\text{C}$ (plus drift of REF)

#### Board Size

1 double height board, single module width

#### Temperature Range

$+10^{\circ}\text{C}$  to  $+50^{\circ}\text{C}$

#### Power

$+15\text{v}$ at 35 ma	} at max. load
$-15\text{v}$ at 60 ma	
$+5\text{v}$ at 60 ma	
$-10.0\text{v}$ REF at $-7\text{ ma}$ (reverse current)	

If the Output is accidentally shorted to Ground, the output amplifier will not be damaged.

# 10-BIT D/A CONVERTER SINGLE BUFFERED

**A618 and A619**

## A SERIES

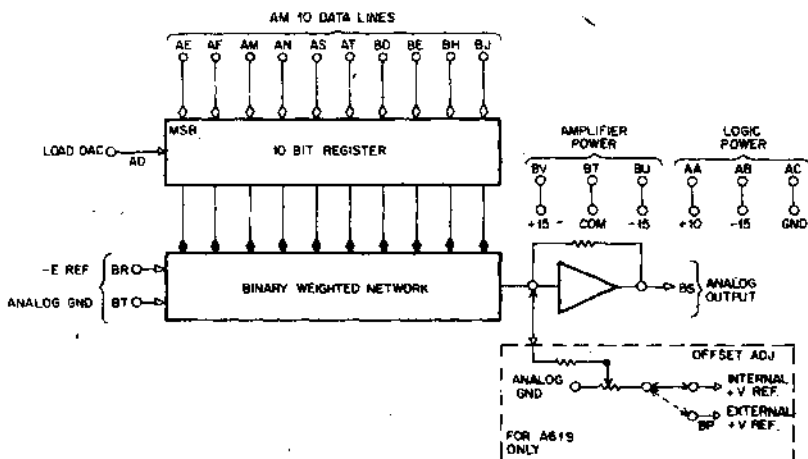

The A618 and the A619 Digital to Analog Converters (DAC) are contained on one DEC double Flip-Chip™ Module. These modules are also double width in the lower (B section) half. The converters are complete with a 10-bit buffer registers, level converters, a precision divider network, and a current summing amplifier capable of driving external loads up to 10 ma. The reference voltage is externally supplied for greatest efficiency and optimum scale factor matching in multi-channel applications.

The A619 DAC output voltage is bi-polar while the A618 DAC output voltage is uni-polar.

Binary numbers are represented as shown (right justified) in Table 1:

**TABLE 1**

Binary Input	Analog Output (Standard)	
	A618	A619
0000 <sub>x</sub>	0v	-10v or -5v
0400 <sub>x</sub>	+2.5v	-5v or -2.5v
1000 <sub>x</sub>	+5.0v	0 volts
1400 <sub>x</sub>	+7.5v	+5v or +2.5v
1777 <sub>x</sub>	+10.0v	+10v or +5v

A618—\$300  
A619—\$325



**OUTPUT:**

Voltage: (A618—Standard)	0 to +10 volts
Voltage: (A619—Standard)	$\pm 5$ or $\pm 10$ volts
Current:	10 ma MAX.
Impedance:	$< 0.1$ ohm
Settling Time:	
(Full scale step, resistive load)	$< 5.0$ $\mu$ sec
(Full scale step, 1000 pf)	$< 10.0$ $\mu$ sec
Resolution:	1 part in 1024
Linearity:	$\pm 0.05\%$ of full scale
Zero Offset:	$\pm 5$ mv MAX.
Temperature Coefficient:	$< 0.2$ mv/ $^{\circ}$ C
Temperature Range:	0 to $50^{\circ}$ C

**INPUT**

Level: 1 TTL Unit Load	
Pulse: (positive)	
Input loading: 20 TTL Unit load	
Rise and Fall Time:	20 to 100 nsec
Width:	$> 50$ nsec
Rate:	$10^6$ HZ max.
Timing:	

Data lines must be settled 40 nsec before the "LOAD DAC" pulse (transition) occurs.

**POWER REQUIREMENTS:**

Reference Power:	-10.06 volts, 60 ma
Amplifier Power:	$\pm 15$ volts, 25 ma (plus output loading)
Logic Power:	+5 volts, 135 ma
	-15 volts, 60 ma

**NOTES:**

\*Voltage—A619: Full scale voltage ( $\pm 5$  or  $\pm 10$ ) must be specified at time of purchase.

Price: Price stated is for standard output voltage and current. Other output characteristics are available on request.

**10-BIT D/A CONVERTER  
DOUBLE BUFFERED  
TYPES A620 and A621**

**A  
SERIES**

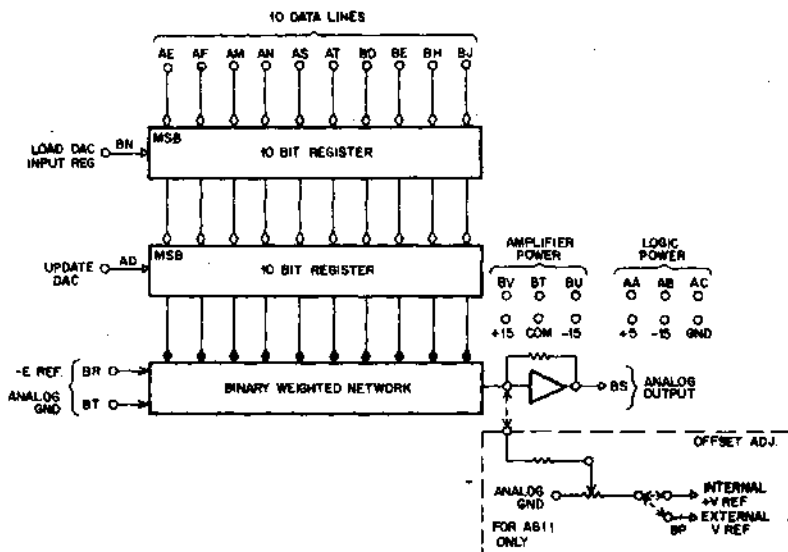

The A620 and the A621 Digital-to-Analog Converters (DAC) are contained on one DEC double Flip-Chip Module. These modules are also double-width in the lower (B section) half. The converters are complete with two 10-bit buffer registers, level converters, a precision divider network, and a current summing amplifier, capable of driving external loads up to 10 ma. The reference voltage is externally supplied for greatest efficiency and optimum scale-factor matching in multi-channel-application.

The A621 DAC output voltage is bi-polar while the A620 DAC output voltage is uni-polar.

The double-buffered DAC's are offered to satisfy those applications where it is imperative to update several analog output simultaneously. When DAC's deliver input to a multi-channel analog tape system or update the constants of an analog computer, the double-buffer feature may be necessary to prevent skew in the analog data.

A620—\$300  
A621—\$375

Binary numbers are represented as shown (right justified) in Table 1:

TABLE 1

Binary Input	Analog Output (Standard)	
	A620	A621
0000 <sub>R</sub>	0v	-10v or -5v
0500 <sub>R</sub>	+2.5v	-5v or -2.5v
1000 <sub>R</sub>	+5.0v	-0 volts
1500 <sub>R</sub>	+7.5v	+5v or +2.5v
1777 <sub>R</sub>	+10.0v	+10v or +5v

**OUTPUT:**

Voltage: (A620—Standard)	0 to 10 volts
Voltage: (A621—Standard*)	±5 or ±10 volts
Current:	10 ma MAX.
Impedance:	<0.1 ohms
Settling Time:	
(Full scale step, resistive Load)	<5.0 μsec
(Full scale step, 1000 pf)	<10 μsec
Resolution:	1 part in 1024
Linearity:	±0.05% of full scale
Zero Offset:	±5 mv MAX.
Temperature Coefficient:	<0.2 mv/°C
Temperature Range:	0 to 50°C

**INPUT:**

Level: 1 TTL Unit load	
Pulse: (positive)	
Input loading:	20 TTL Unit load
Rise and Fall Time:	20 to 100 nsec
Width:	>50 nsec
Rate:	10 <sup>6</sup> Hz MAX.

**Timing:**

1. Data lines must be settled 40 nsec before the "LOAD DAC" pulse (transition) occurs.
2. The "Update DAC" pulse must occur more than 100 nsec after the "LOAD DAC" pulse.

**POWER REQUIREMENTS:**

Reference Power:	-10.6 volts, 60 ma
Amplifier Power:	±15 volts, 25 ma (plus output loading)
Logic Power:	+ 5 volts, 190 ma
	-15 volts, 60 ma

**Notes:**

\*Voltage—A621: Full scale voltage (±5 or ±10) must be specified at time of purchase.

**Price:**

Price stated is for standard output voltage and current. Other output characteristics are available on request.

# 12 BIT MULTIPLYING DIGITAL TO ANALOG CONVERTER

A660

**A  
SERIES**

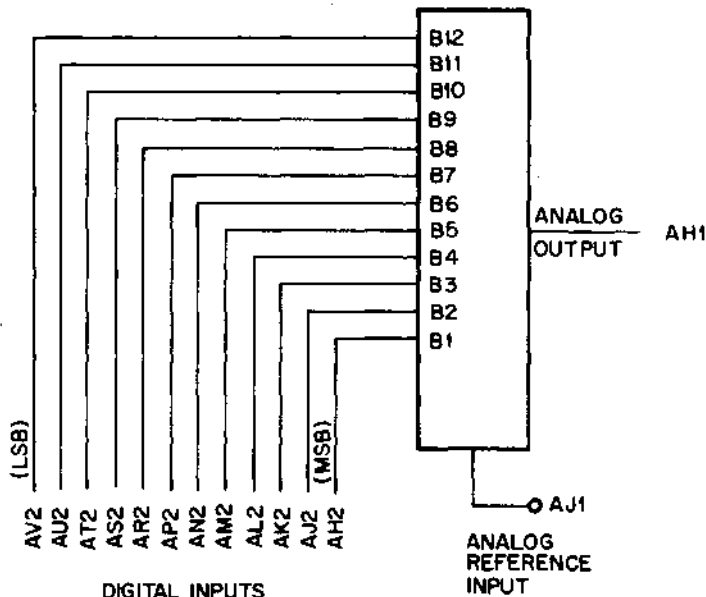

+15V	AD1, AD2
-15V	AE1, AE2
ANALOG RETURN	AF1, AF2
+5V	AA1, AA2, BA1, BA2
DIGITAL RETURN	AC2, BC2

The A660 is a precision 12 bit multiplying digital to analog converter whose output is the product of the external analog references voltage supplied and digital code presented.

This D/A converter is DTL and TTL compatible, requires essentially zero warmup time, and has high output current drive capabilities. It also may be used in either unipolar or operations.

This unit may be used in applications where precision digital control must be exercised over an analog signal. It also may be used in systems requiring synchro to digital conversion, AC transducer digitization, or in hybrid computation.

A660—\$500

When operating in conjunction with an external DC reference source, the A660 may be used as a conventional D/A converter with the output polarity determined by the references polarity.

The A660 employs advance shielding techniques which allow proper operation under normal ambient electrostatic and electromagnetic conditions.

### SPECIFICATIONS

Number of Bits:	12
Coding:	Binary—Absolute Value
Input Logic Levels:	High = Logic One 1 TTL Load
Accuracy—(DC to 4 KHz)	$\pm 0.025\%$ FS, $\pm 0.01\%$ of reading
Temp. Coefficient of Offset:	200 microvolts/ $^{\circ}$ C.
Temp. Coefficient of Range:	20 PPM/ $^{\circ}$ C.
Feedthrough (for 20 v. p-p sine wave; all bits off):	at 1 KHz: $\cdot 1$ mV RMS
Analog Reference Input Range:	$\pm 10$ v. Full Scale
Input Impedance:	10 K
Frequency:	Down 0.02% at 20 KHz
Phase Shift:	$< 7^{\circ}$ at 20 KHz
Output Range:	$\pm 10$ v.
Output Current:	15 ma.
Short Circuit Protection:	Indefinitely to ground
Phase	Output in Phase with Ref.
<b>Attenuation Range—Absolute Value</b>	
	DIGITAL
000 000 000 000	0.0000 Volts
111 111 111 111 Binary	(0.9976) X (Input Ref.) Volts
Settling Time to Digital Change:	10ms.
Size:	One double height double width module.
<b>Power Requirement:</b>	+15v @ 14 ma. -15v @ 3 ma. +5v @ 20 ma.

**REFERENCE SUPPLIES**  
**A702, A704**  
**(DOUBLE HEIGHT)**

**A**  
**SERIES**

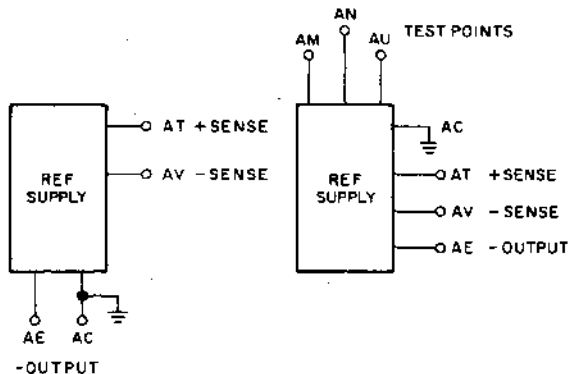

Module Type	Output	Current	Temperature Coefficient	Regulation	Peak Peak to Ripple
A702	-10 v	±60 ma	1mv/°C	30 mv, no load to full load	10 mv
A704	-10 v	-90 to +40 ma	1 mv/8hrs 1 mv/15° to 35°C 4 mv/0° to 50°C	0.1 mv, no load to full load	0.1 mv

Module Type	Adjustment Resolution	Input Power	Use	Output Impedance
A702	5 mv	-15 v/100 ma +10 v (B)/10 ma	Load with 500µf at load. May also be preloaded if desired	0.5 ohms
A704	0.01 mv	-15 ±2 v/250 ma	See below for sensing and preloading	0.0025 ohms

**Remote Sensing:** The input to the regulating circuits of the A704 is connected at sense terminals AT (+) and AV (-). Connection from these points to the load voltage at the most critical location provides maximum regulation at a selected point in a distributed or remote load. When the sense terminals are connected to the load at a relatively distant location, a capacitor of approximately 100 µf should be connected across the load at the sensing point.

A702—\$58  
A704—\$175

**Preloading:** The supplies may be preloaded to ground or  $-15\text{v}$  to change the amount of current available in either direction. For driving DEC Digital-Analog Converter modules,  $-125\text{ ma}$  maximum can be obtained by connecting a  $270\Omega \pm 5\%$  1 watt resistor from the  $-10\text{v}$  pin AE reference output to pin AC ground (A704 only).

**Pin Connections:** The A704 is a double-sized module. The top pin letters are prefixed A.

**Wiring:** Digital-analog and analog-digital converters perform best when module locations and wiring are optimized. All Digital-Analog Converter modules should be side-by-side. In an analog-digital converter, the comparator should be mounted next to the converter module for the bits of most significance. The reference supply modules should be mounted nearby, and if the A704 is used, its sense terminals should be wired to the most-significant-bits converter module. The high quality ground must be connected to the common ground only at pin AC of the reference supply module, and this point should also be the common ground for analog inputs to analog-digital converters. Do not mount A-series modules closer than necessary to power supply transformers or other sources of fluctuating electric or magnetic fields.

# 10 BIT A/D CONVERTER

A811

**A  
SERIES**

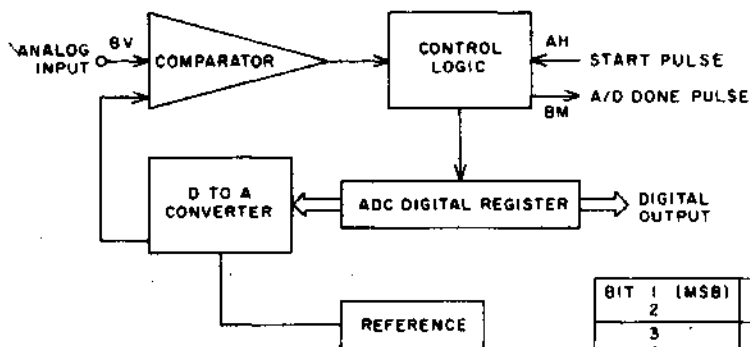

A801 10-BIT ANALOG-TO-DIGITAL CONVERTER

BIT 1 (MSB)	AE
2	AD
3	AN
4	AM
5	BL
6	BR
7	BK
8	BP
9	BS
10 (LSB)	BT

## A811 10-BIT ANALOG-TO-DIGITAL CONVERTER

The A-811 is a complete, 10-bit successive approximation, analog to digital converter with a built in reference supply. The complete converter is contained on one DEC double FLIP CHIP™ logic module. Conversion is initiated by raising the Convert input to logic 1 (+4 volts). The digital result is available at the output within 10 microseconds. An A/D Done Pulse is generated when the result is valid. The A-811 uses monolithic integrated circuits for control logic, output register, and comparator.

The A811 requires 2 vertical connectors and the top section (connector A) requires 2 connector widths.

**A811—\$350**



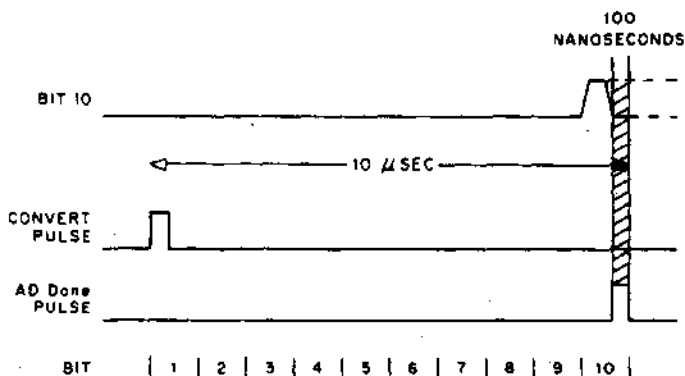

### SPECIFICATIONS:

	Max.	Min.
<b>Convert Pulse Input:</b>		
Input loading	10 TTL unit load	
Pulse Width	500 nsec	100 nsec
Pulse Rise Time	250 nsec	—
<b>A/D Done Pulse Output:</b>		
Pulse Width	300 nsec	100 nsec
<b>Digital Output:</b>		
Logical "0"	+0.4v	0v
Logical "1"	+3.6v	+2.4v
Output Current "0"	16 ma	
Output Current "1"	-0.4 ma	
<b>Input:</b>		
Input Voltage	0 to +10v	
Input Impedance	1000 ohms	
<b>Resolution:</b>	10 bits	
<b>Accuracy:</b>	0.1% of full scale	
<b>Temperature:</b>		
<b>Coefficient:</b>	0.5 mv/°C	
<b>Operating Temperature:</b>	0°C to 50°C	
<b>Conversion Rate:</b>	100 KHz MAX.	
<b>Output Format:</b>	Parallel Binary Uni-polar	
+15 volts ±1% 20 ma (pin BU)		
-15 volts ±1% 160 ma (pin AV)		
+ 5 volts ±1% 300 ma (pin AA)		

Analog Ground (pin BN)

### Options:

The input impedance of the A/D converter can be raised to greater than 100 megohms by adding an input amplifier module. A sample and hold amplifier module may also be included. The impedance of the converter with sample and hold is 10,000 ohms. Both options may be included simultaneously if high impedance and narrow aperture are both required.

# 12 BIT INDUSTRIAL CONVERTER

A860

A  
SERIES

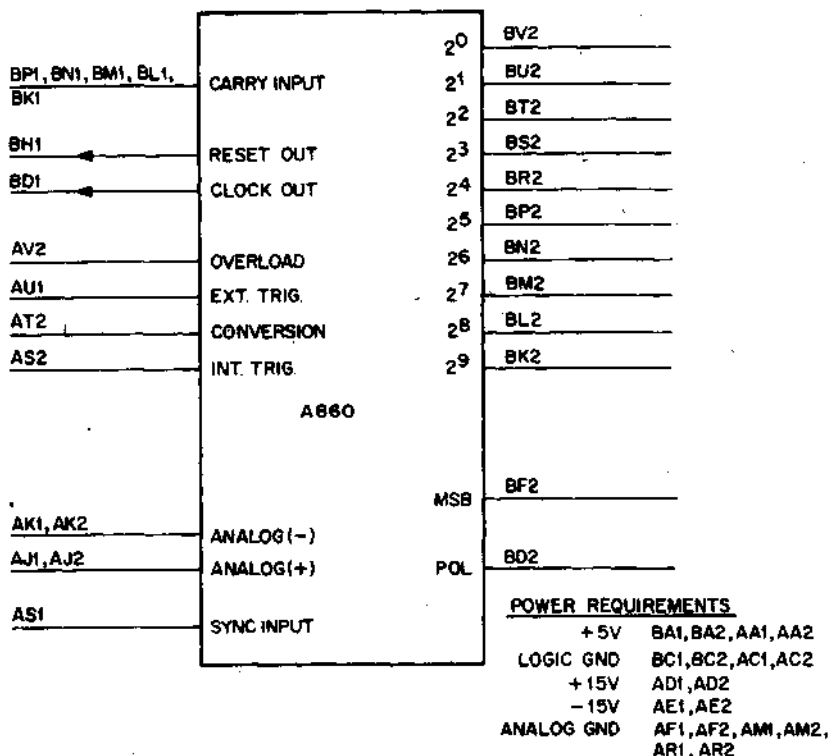

The A860 is a 12 bit industrial converter employing dual slope integrating techniques whereby an analog signal is converted into 12 bits (11 bits + sign) of digital information in 9 milliseconds.

This unit may be used in industrial systems where sensing of an analog signal is essential in the control of a digital system.

The A860 may be used in application where the output of analytical instruments, strain gauges, and resistance bridges must be converted into digital form. Other uses of this module are industrial and machine tool control and conversion of instrumentation to digital displays. Because of its bit rate (1200—3600 BPS), the A860 may also be used to transmit data over telephone lines.

The A860 is both DTL and TTL compatible and may be used with standard K and M Series modules, as well as DEC's A Series multiplexers and sample and hold.

A860—\$395

The A860 has been engineered and designed using advance shielding techniques which allow proper operation under normal ambient electrostatic and electromagnetic conditions.

### SPECIFICATIONS

Technique:	Dual Slope Integration
Input Voltage Range:	$\pm 2$ volt
Coding:	Sign bit + 11 magnitude bits
Accuracy at 23° C.:	$\pm 0.05\%$ of input voltage $\pm 1$ millivolt
Conversion Time:	9 milliseconds
Sample Aperture (part of conv. time):	3 milliseconds
Input Type:	Differential
Input Impedance:	$> 1000$ meg ohms
Common Mode Voltage:*	0.25 V max.
Common Mode Rejection:	$> 70$ db at 60 Hz
Control Inputs	
Internal Trigger:	Internal oscillator provided for autonomous operation of converter; can be enabled by grounding internal trigger line.
External Trigger:	Triggered by leading (negative-going voltage) edge 1 TTL load. Internal trigger must be disabled by hard wire to +5volts.
Digital Outputs—	
Data (11 lines):	Parallel data available after end of conversion. Logic one is high; 8 TTL loads.
End of Conversion (Busy Status):	Output logic one during conversion. High to low transition indicates end of conversion.
Carry Input:	Input to control flip flop that determines word length of converter. For 11 bits + sign, connect carry input (BK1) to 29 out (BK2).
Overload:	Output logic one when analog exceeds full scale
Power Requirements:	$\pm 15V \pm 0.3\%$ at 20 ma. $+5V$ at 150 ma.
Size:	One double height double width module.

\* Note: Unit normally supplied with analog minus input connected to analog return through R6 (r). For differential inputs remove R6.

**HIGH SPEED 12 BIT  
A/D CONVERTERS  
A861 A862**

**A  
SERIES**

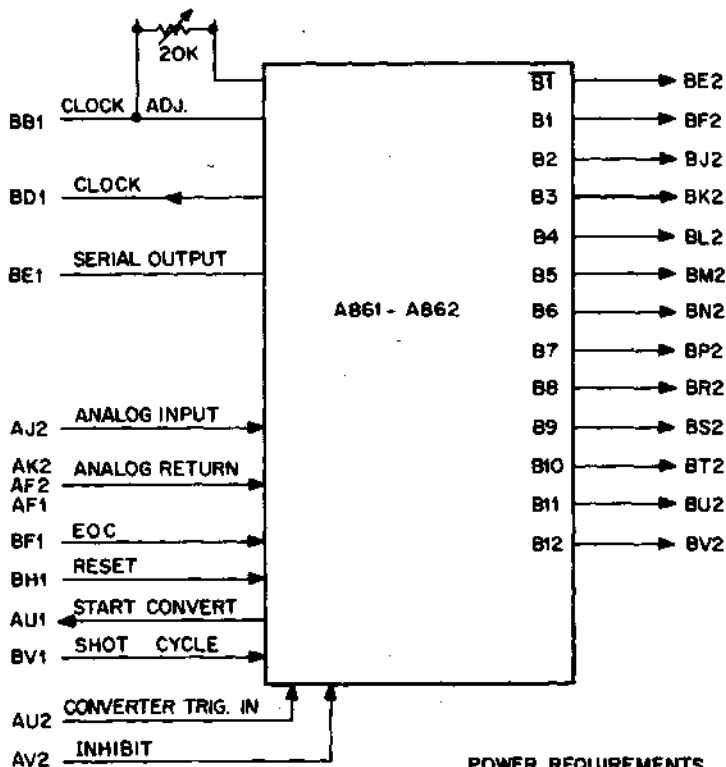

**POWER REQUIREMENTS**

+5V	BA2, AA2, BA1, AA1
LOGIC GROUND	BC2, AC2, BC1, AC1
-15V	AE1, AE2
+15V	AD1, AD2
ANALOG RETURN	AK2, AF2, AF1

The A861 and A862 are high speed analog/digital converters that provide adjustment-free 12 bit accuracy over the specified temperature range.

The A861 is a unipolar converter with an input range of 0 to +10 volts and a straight binary output, whereas the A862 is a bipolar converter whose input is in the  $\pm 10$  volt range with an output that is coded offset binary or 2's complement.

A861—\$595  
A862—\$595

Both of these modules employ the successive approximation techniques and include a self-contained clock and trigger circuitry that will allow adjustment of the conversion time to a level from 12 microseconds to 48 microseconds.

The A861 and A862 are DTL and TTL compatible and may be used with standard M and K Series modules, as well as standard DEC hardware for system configuration.

Both A/D converters are packaged on a double-height double-width module and contain internal reference supplies that are adjustable. In packaging the A861 and A862, advance shielding techniques have been employed to allow stable operation under ambient electrostatic and electromagnetic conditions. To minimize potential ground loop problems, separate ground returns are brought to:

- a. Digital power supply return pin.
- b. Analog power supply return pin.
- c. Analog signal return pin.

Both of these modules are useful in systems demanding high integral accuracy and long term reliability, such as computer linkage, biomedical data transmission, process control, and conversion of instrumentation data.

Range and offset adjustments are provided on the module.

## SPECIFICATION

### A861 (UNIPOLAR)

### A862 (BIPOLAR)

Technique:	Successive Approximation	Successive Approximation
Resolution:	12 Bits	12 Bits
Accuracy vs. speed @ 23°C:	± 0.01% of FS. @ 48 μsec conv. ± 0.015% of FS. @ 24 μsec conv. ± 0.05% of FS. @ 12 μsec conv.	± 0.01% of FS. @ 48 μsec conv. ± 0.015% of FS. @ 24 μsec conv. ± 0.05% of FS. @ 12 μsec conv.
Reference:	Internal +5V and +10V supplies; adjustable	Internal +5V and +10V supplies; adjustable
Code:	Straight binary	OFFSET Binary or 2's complement
Temp. Coeff. of Offset:	± 0.001%/°C	.001%/°C
Temp. Coeff. of Gain:	(20 ppm/°C) X Input Voltage Applied	(20 ppm/°C) X Input Voltage Applied
Signal Input Load:	2.5K ohms returned to +5 volts	5000 ohms returned to +5 volts
Input Range:	0 to +10V	-10V to +10V.
Data Output-Parallel:	True side of all bits 7 TTL unit loads.	True side or All Bits plus false side of MSB 7 TTL unit loads.
Clock Adjustment (Multi-Turn Pot):	Variable from 12 to 48 microsecond conversion time	Variable from 12 to 48 microsecond conversion time
End of Conversion Output:	Goes High During Conversion; Returns to low state @ at end of conversion 8 TTL LOADS	Goes High During Conversion; Returns to low state @ at end of conversion 8 TTL LOADS
Serial Data (available during conversion):	NRZ code available (Binary) 8 TTL loads	NRZ code available (offset binary) 8 TTL loads
Converter Trigger:	Triggered on the leading (negative-going voltage) edge, 1 TTL load	Triggered on the leading (negative-going voltage) edge, 1 TTL load
Inhibit Trigger:	Logic zero inhibits	Logic zero inhibits 1 TTL load
Power Requirements:	+ 15V @ 55 ma. - 15V @ 12 ma. + 5V @ 420 ma.	+ 15V @ 55 ma. - 15V @ 12 ma. + 5V @ 420 ma.
Size:	One double height double width module.	One double height double width module.

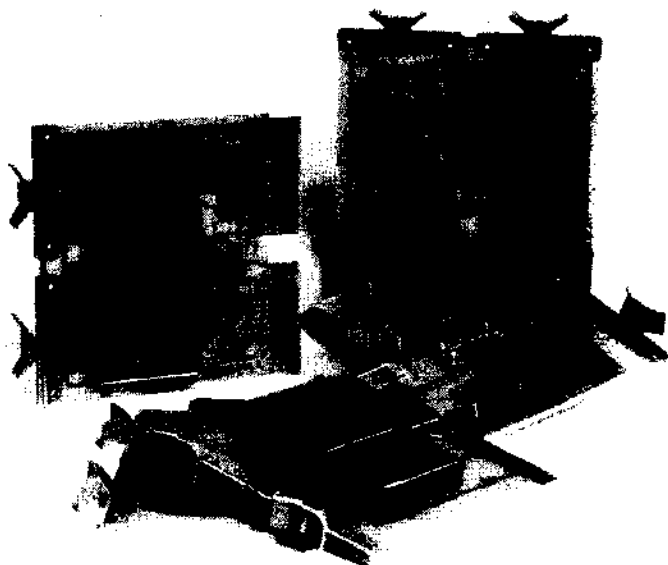

The A Series analog module line has been substantially expanded. Shown here are a few of the new units.

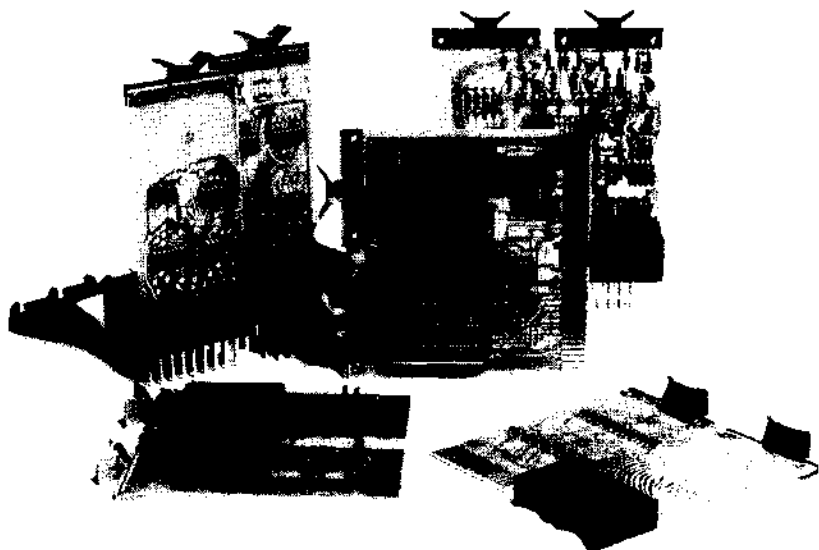

The A Series additions are DTL and TTL compatible and compatible with DEC K and M Series modules, computers, control systems and standard instrumentation.

## DUAL POWER SUPPLY

H704, H707

15 Volts

POWER  
SUPPLY

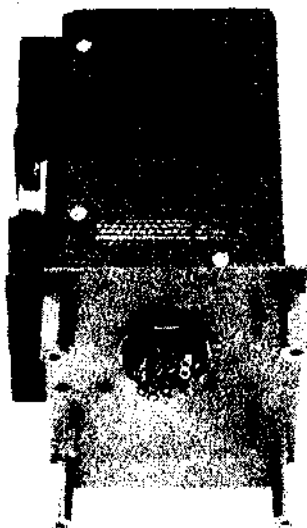

H704

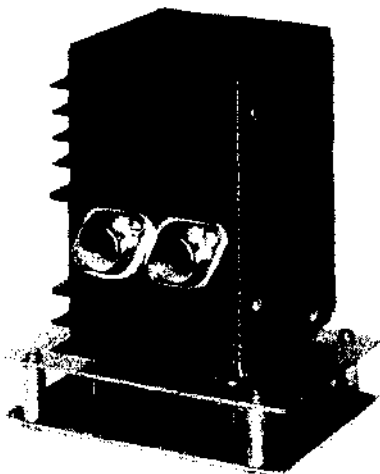

H707

These supplies differ only in dimensions and output current capabilities: 400 ma and 1.5 Amperes respectively for the H704 and H707. May be mounted on the bars in an H920 drawer, taking the space of two connector blocks.

### MECHANICAL CHARACTERISTICS

DIMENSIONS:  $3\frac{1}{4}$  x  $3\frac{3}{8}$  x 5 in. height (H704)

DIMENSIONS: 4" x 5" x  $5\frac{1}{2}$ " height (H707)

CONNECTIONS: All input-output wires must be soldered to octal socket at the base of the power supply.

OPERATING TEMPERATURE: -20 to +71°C ambient

---

H704—\$200

H707—\$400

---



#### POWER CONNECTIONS:

Input power connections are made via tab terminals which fit the AMP "Faston" receptacle series. Output power is supplied to solder lugs. All required mounting hardware is supplied with this unit. See 914 power jumpers.

Length: 8"  
Width: 5"

Height: 6"  
Finish: Chromicoat

#### ELECTRICAL CHARACTERISTICS

INPUT VOLTAGE: 105 to 125 vac; 47-420 cps.

OUTPUT VOLTAGE: floating 15 v

OUTPUT VOLTAGE ADJUSTMENT:  $\pm 1$  v each output

REGULATION: 0.05% line, 0.1% load for both voltages

RIPPLE: 1 mv rms max for both outputs

OVERLOAD PROTECTION: The power supply is capable of withstanding output short circuits indefinitely without being damaged.

IF REMOTE SENSING IS NOT USED, CONNECT: 5 TO 4  
6 TO 7

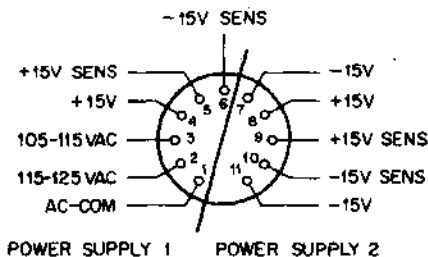

The H704 and H707 contain two 15 volt floating power supplies. To get  $\pm 15$  volt supply, connect pins 7 and 8 and use this point as ground. Pin 4 will now be at positive 15 volts and pin 11 will be negative 15 volts.



The Module Assembly area has shifted emphasis from volume production to complex experimental work. The above process is a special sub-assembly of an indicator light board designed for a control unit.

# Universal Hardware and Accessories

Digital manufactures a complete line of hardware accessories in support of its module series. Module connectors are available for as few as one module and as many as 64. A complete line of cabinets is available to house the modules and their connector blocks, as well as providing a convenient means for system expansion. Power supplies for both large and small systems and reference supplies are also available.

Coupled with the recent additions to the hardware line, Digital has made every effort to maintain or improve the high standards of reliability and performance of its present line. Through the availability of a wide range of basic accessories, DEC feels that it is offering the logic designer the necessary building blocks which he requires for complete system design.

## 50-CYCLE POWER

Because of the demand for Digital's products in areas where 115-v, 60-cps power is not available, each of the power supplies with a frequency-sensitive regulating transformer is also available in a multi-voltage 50-cps version. All 50-cps supplies have the same input connections. The line input is on pins 3 and 4. Jumpers should be connected depending on the input voltage.

## WIRING HINTS

These suggestions may help reduce mounting panel wiring time. They are not intended to replace any special wiring instructions given on individual module data sheets or in application notes. For fastest and neatest wiring, the following order is recommended.

- (1) All power & ground wiring and any horizontally bussed signal wiring. Use Horizontal Bussing Strips Type 932 or Type 933.
- (2) Vertical grounding wires interconnecting each chassis ground with pin C grounds. Start these wires at the uppermost mounting panel and continue to the bottom panel. Space the wires 2 inches apart, so each of the chassis-ground pins is in line with one of them. Each vertical wire makes three connections at each mounting panel.
- (3) All other ground wires. Always use the nearest pin C above the pin to be grounded, unless a special grounding pin has been provided in the module.
- (4) All signal wires in any convenient order. Point-to-point wiring produces the shortest wire lengths, goes in the fastest, is easiest to trace and change, and generally results in better appearance and performance than cabled wiring. Point-to-point wiring is strongly urged.

The recommended wire size for use with the H800 mounting blocks and 1943 mounting panels is 24 for wire wrap, and 22 for soldering. The recommended size for use with H803 block and H911 mounting panels is #30 wire. Larger or smaller wire may be used depending on the number of connections to be made to each lug. Solid wire and a heat resistant spaghetti (Teflon) are easiest to use when soldering.

Adequate grounding is essential. In addition to the connection between mounting panels mentioned above, there must be continuity of grounds between cabinets and between the logic assembly and any equipment with which the logic communicates.

When soldering is done on a mounting panel containing modules, a 6-v (transformer) soldering iron should be used. A 110-v soldering iron may damage the modules.

When wire wrapping is done on a mounting panel containing modules, steps must be taken to avoid voltage transients that can burn out transistors. A battery- or air-operated tool is preferred, but the filter built into some line-operated tools affords some protection.

Even with completely isolated tools, such as those operated by batteries or compressed air, a static charge can often build up and burn out semiconductors. In order to prevent damage, the wire wrap tool should be grounded except when all modules are removed from the mounting panel during wire wrapping.

### **AUTOMATIC WIRING**

Significant cost savings can be realized in quantity production if the newest automatic wiring techniques are utilized. Every user of FLIP CHIP modules benefits from the extensive investment in high-production machinery at Digital, but some can go a step further by taking advantage of programmed wiring for their FLIP CHIP digital systems.

While the break-even point for hand wiring versus programmed wiring depends upon many factors that are difficult to predict precisely, there are a few indications:

1. One-of-a-kind systems will probably not be economical with automatic wiring, even when the size is fairly large; programming and administrative costs are likely to outweigh savings due to lower costs in the wiring itself.

2. At the other end of the spectrum, production of 50 or 100 identical systems of almost any size would be worth automating, not only to lower the cost of the wiring itself but also to reduce human error. At this level of volume, machine-wired costs can be expected to be less than the cost of hand wiring.
3. For two to five systems of several thousand wires each, a decision on the basis of secondary factors will probably be necessary: ease of making changes, wiring lead time, reliability predictions, and availability of relevant skills are factors to consider.

The Gardner-Denver Corporation, and Digital can supply further information to those interested in programmed wiring techniques. At Digital, contact the Module Sales Manager, Sales Department.

### COOLING OF FLIP CHIP MODULES

The low power consumption of K and M series modules results in a total of only about 25 watts dissipation in a typical 1943 Mounting Panel with 64 modules. This allows up to six panels of modules to be mounted together and cooled by convection alone, if air is allowed to circulate freely. In higher-dissipation systems using modules in significant quantities from the A series, the number of mounting panels stacked together must be reduced without forced-air cooling. In general, total dissipation from all modules in a convection-cooled system should be 150 watts or less.

The regulating transformers used in most DEC power supplies have nearly constant heat dissipation for any loading within the ratings of the supply. Power dissipated within each supply will be roughly equal to half its maximum rated output power. If power supplies are mounted below any of the modules in a convection-cooled system, this dissipation must be included when checking against the 150 watt limit.

## MOUNTING PANEL HARDWARE

H001, H002, H020, H021, H022

UNIVERSAL  
HARDWARE

### PAIRS OF SETBACK BRACKET:

H001 —  $\frac{3}{4}$ " standoff used to mount a 1907 over K943 wiring as shown in the description of the K943.

H002 — 2" setback-used to mount a control panel with switches, lamps, etc. This setback brings the control panel up flush with the mounting rack or cabinet in front of the logic wiring.

### MOUNTING FRAMES

H020 — Mounting frame casting upon which H800, H803, H808 connector blocks, power supplies, such as, the H710 and other components that are adaptable to the frame mounting requirements can be mounted.

H021 — Single offset end plate which mounts to the H020. This end plate provides a mount for the 1945-19 hold down bar, if required.

H022 — Single end plate similar to the H021 on which is mounted a terminal block assembly for ease of parallel power wiring to adjacent panels.



H020

---

H001-PR	—\$8
H002-PR	—\$8
H020	—\$15
H021	—\$7
H022	—\$20

---

# CONNECTOR BLOCKS

## H800-W, H800-F

UNIVERSAL  
HARDWARE

This is the 8-module socket assembly used in Flip-Chip® mounting panels. Because of its 18 pin connectors, it can be used for all modules except those with pins on both sides of the board. Pin dimensions are .031 inches by .062 inches and may be of either a wire wrap or solder fork type. Number 24 wire should be used with these connectors.

The drawings below show the pertinent dimensions.

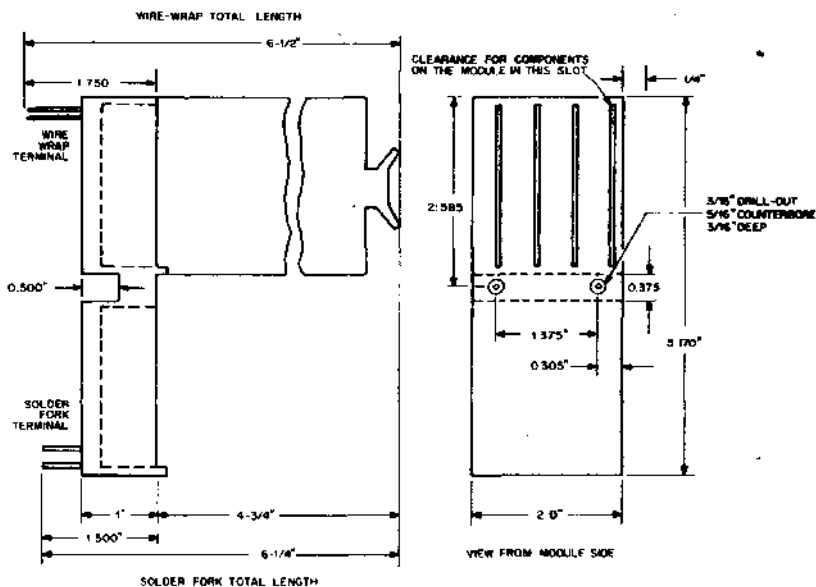

### REPLACEMENT CONTACTS TYPES H801-W, H801-F

These contacts are offered in packages of 18 for replacement purposes. In each package, nine straight and nine offset contacts are included, enough to replace all contacts in one socket.

H801-W is for wire-wrap connectors; H801-F is for solder-fork connectors.

H800F	—\$8
H800W	—\$8
H801F	—\$2
H801W	—\$2

**CONNECTOR BLOCK  
H802**

**UNIVERSAL  
HARDWARE**

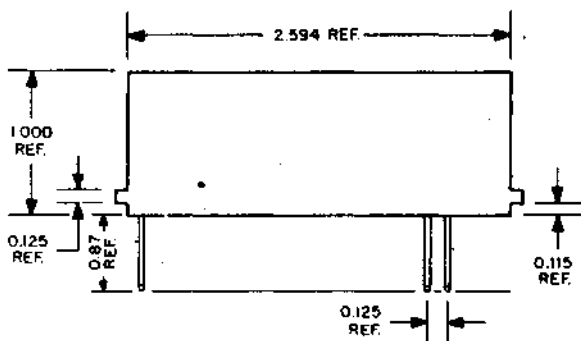

This is an 18 pin connector block for a single FLIP CHIP® module. It can be used to mount all modules except those with pins on both sides of the board. Pin dimensions are .031 inches by .062 inches and may be of the wire wrap type only. Number 24 wire should be used with this connector.



H802—\$4



# CONNECTOR BLOCK

## H808, H809 PINS

UNIVERSAL  
HARDWARE

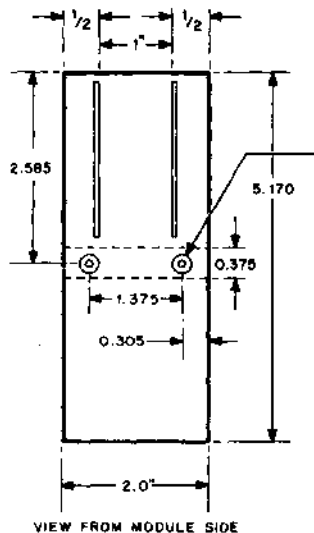
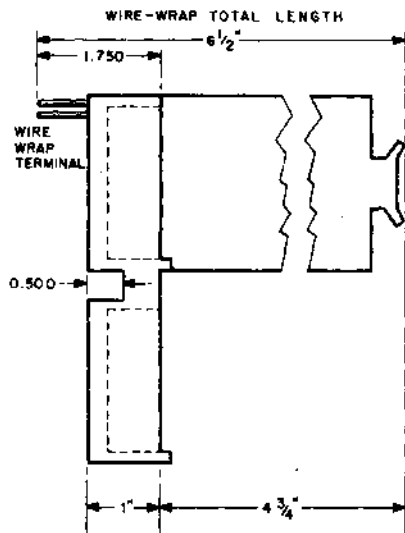

The H808 is a relatively low density connector block for use with all modules in the catalog. This includes A, K, M, and W Series modules. The connector provides 4 module slots each having 36 pins. On A, K and W Series modules only the 2 side pins, (A2, B2, etc.) will make contact. This connector adds a measure of convenience and versatility to the many uses to which these catalog modules can be applied. The dimensions of the connector pins are the same as those for the H800 (.031 inches by .062 inches). Number 24 wire should be used with these blocks, H800 and H808 connector blocks can be mixed for M and A, K, W module mixing purposes. Wire wrapping patterns can be maintained even though module letter series are mixed because H800 and H808 pin layout is identical. H809 is a package of 36 replacement pins, 18 left and 18 right.

H808—\$10  
H809—\$ 4

**WIRING ACCESSORIES**

932, 933, 934, 935, 936  
H810, H811, H812, H813, H814

**UNIVERSAL  
ACCESSORIES**

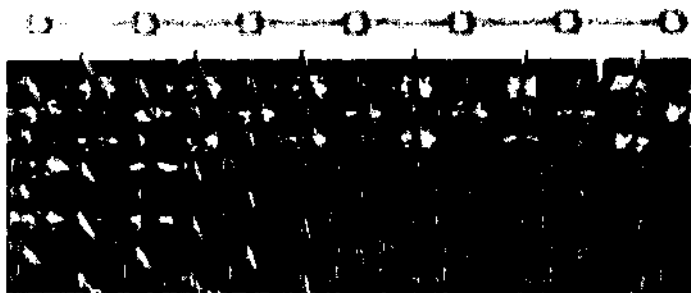
**932 BUS STRIP**

Simplifies wiring of register pulse busses, power, and grounds. Same as used in K943 with H800 blocks.

---

932 — \$0.60

---

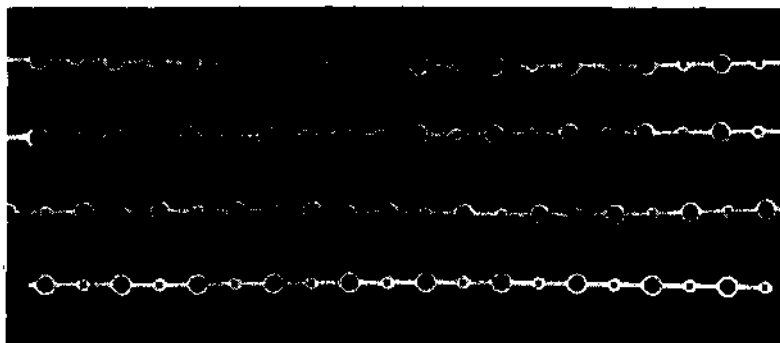
**933 BUS STRIP**

Simplifies wiring of power, ground and signal busses on mounting panels using H803 connectors.

---

933 — \$1

---

**934 WIRE-WRAPPING WIRE**

1000 ft. roll of 24 gauge solid wire with tough, cut-resistant insulation. (Use Teflon insulated wire instead for soldering.)

For use with H800 connectors.

---

934 — \$50

---

### 935 WIRE-WRAPPING WIRE

1000 foot roll of 30 guage insulated solid wire for use with H803 connectors.

935—\$60

### 936 19 CONDUCTOR RIBBON CABLE

Use on W Series connector modules or split into 9-conductor cables for use with K580, K681, K683, etc.

936—\$0.60/ft.

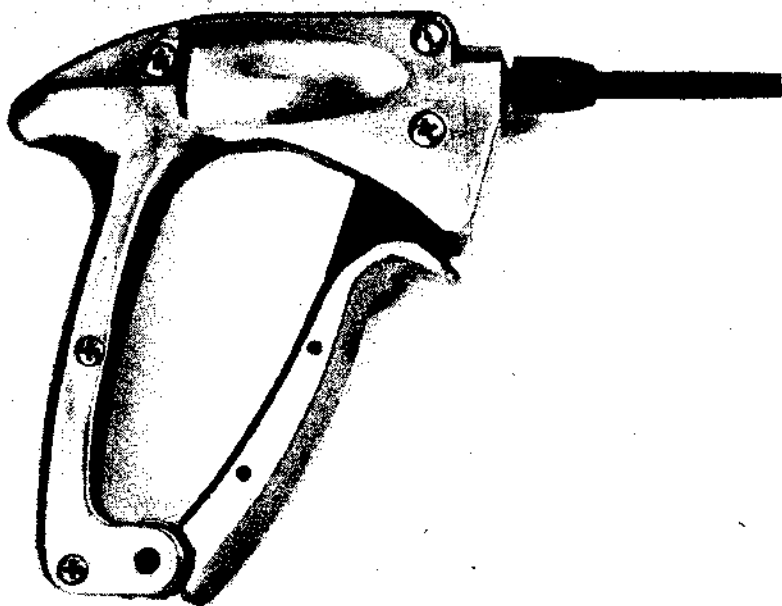

### H810 PISTOL GRIP HAND WIRE WRAPPING TOOL

The type-H810 Wire Wrapping Tool is designed for wrapping #24 or #30 solid wire on Digital-type connector pins. The H810 Kit includes the proper sleeves and bits. It is recommended that five turns of bare wire be wrapped on these pins. This tool may also be purchased from Gardner-Denver Co. (Gardner-Denver part No. 14H-1C) with No. 26263 bit and No. 18840 sleeve for wrapping #24 wire. Specify bit #504221 and sleeve #500350 for wrapping #30 wire.

When ordering from Digital, specify the sleeve and bit size desired:

H810—#24 wire  
H810A—#30 wire  
H810B—#24 and #30 wire

H810(24)—\$ 99  
H810A—\$ 99  
H810B—\$150

  
**H812**  

The Type H811 Hand Wrapping tool is useful for service or repair applications. It is designed for wrapping #24 solid wire on DEC Type H800-W connector pins. This tool may also be purchased from Gardner-Denver Co. as Gardner-Denver Part #A20557-12.

Wire wrapped connections may be removed with the Type H812 Hand Unwrapping tool. This tool may also be purchased from Gardner-Denver Co. as Gardner-Denver Part #500130.

The H811A and H812A are equivalent to the H811 and the H812 except that the A versions are designed for #30 wire. Both tools may be purchased from Gardner-Denver directly under the following part numbers: H811A A-20557-29; H812A 505 244-475. The H813 is a #24 bit; H813A, a #30 bit. The H814 is a #24 sleeve; H814A, a #30 sleeve.

None of the Wire Wrapping Tools will be accepted for credit under any circumstances.

H811(24) — \$21.50
H811A(30) — \$21.50
H812(24) — \$10.50
H812A(30) — \$10.50

H813(24) — \$30
H813A(30) — \$30
H814(24) — \$21
H814A(30) — \$21

<b>WIRING ACCESSORIES</b> 913, 914, 915 H820, H821, H825, H826
--

<b>UNIVERSAL ACCESSORIES</b>
------------------------------

**913 AND 915 PATCHCORDS**

These patchcords provide slip-on connections for FLIP CHIP mounting panels and are available in color-coded lengths of 2, 3, 4, 6, 8, 12, 16, 24, 32, 48, and 64 inches. All cords are shipped in quantities of 100 in handy polystyrene boxes. Type 913 patchcords are for 24 gauge wirewrap and use AMP Terminal Type #60530-1. Type 915 patchcords are for 30 gauge wirewrap and use AMP Terminal Type #85952-3.

**H820 AND H821 GRIP CLIPS FOR SHIP-ON PATCHCORDS**

The type H820 and H821 GRIP CLIPS are identical to slip-on connectors used in respectively the 913 and 915 patchcords. These connectors are shipped in packages of 1000 and permit fabrication of patchcords to any desired length. H820 GRIP CLIPS will take size 24-20 awg. wire and may be purchased from AMP, Inc. as AMP part #60477-2. H821 GRIP CLIPS will take size 30-24 awg. wire and are AMP part #85952-3.



#### **H825 HAND CRIMPING TOOL**

Type H825 hand crimping tool may be used to crimp the type H820 GRIP CLIP connectors. Use of this tool insures a good electrical connection. This tool may also be obtained from AMP, Inc. as AMP part #90084.

#### **H826 HAND CRIMPING TOOL**

Type H826 hand crimping tool may be used to crimp the type H821 GRIP CLIP connectors. This tool is identical to AMP part #9019-1.

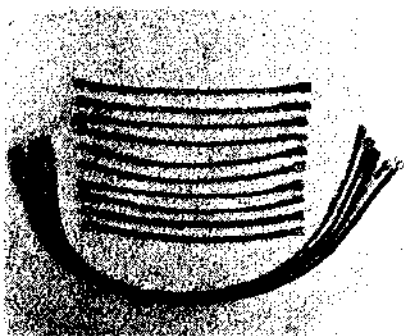

#### **914 POWER JUMPERS**

For interconnections between power supplies, mounting panels, and logic lab panels, these jumpers use AMP "Faston" receptacles series 250. Specify 914-7 for interconnecting adjacent mounting panels, or 914-19 for other runs of up to 19 inches. 914-7 contains 10 jumpers per package; 914-19 contains 10 jumpers per package.

The 914-7 jumpers are 7 inches long and the 914-19 jumpers are 19 inches long.

---

913 — \$18/pkg. of 100
914-7 — \$4/pkg.
914-19 — \$4/pkg.
915 — \$33/pkg. of 100

---

---

H820 — \$48/pkg. of 1000
H821 — \$75/pkg. of 1000
H825 — \$146
H826 — \$210

---

## MODULE DRAWER H920

UNIVERSAL  
HARDWARE

The H920 Module Drawer provides a convenient mounting arrangement for a complete digital logic system. The H920 has space for 20 mounting blocks in addition to an H710, or H716 power supply, or 24 mounting blocks without a supply. It accepts H800, H803, and H808 mounting blocks and fits standard 19" racks. Width of the H920 is 16 $\frac{3}{4}$ ", depth is 19" and height is 6 $\frac{3}{4}$ " including an H921 front panel. The H920 is equipped with a bracket for distributing power within the drawer, or to other drawers or mounting panels. Mounting arrangements are provided for the H921 front panel and H923 slide tracks.

The H921 front panel is designed for use primarily with the H920 Module Drawer. It provides mounting space for switches, indicators, etc. The H921 is pre-drilled and ready to mount on the H920. Height of the H921 is 6 $\frac{3}{4}$ ", width is 19".

H923 chassis slides are intended for use with the H920 Module Drawer. The H923 allows the user to slide the drawer out of the rack and tilt the drawer for easy access.

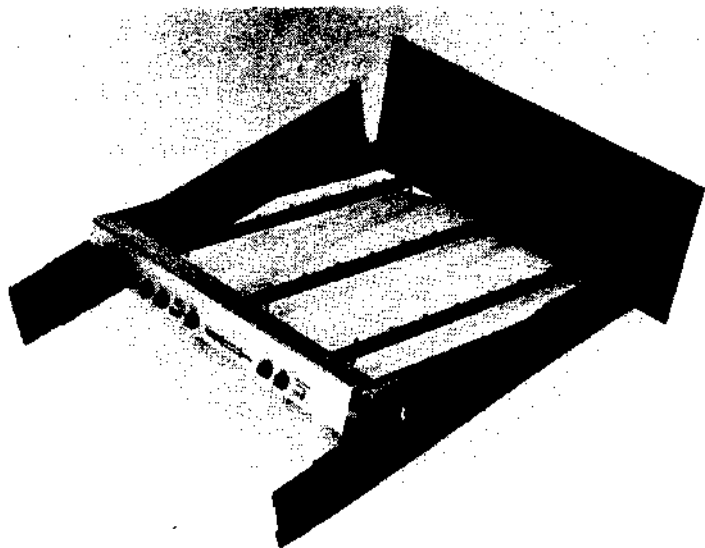

---

H920—	\$170
H921—	\$ 10
H923—	\$ 75

---

## MODULE DRAWER H925

UNIVERSAL  
HARDWARE

The H925 Module Drawer provides mounting space for H800, H803, and H808 connector blocks to accommodate up to 144 modules. The connector blocks mount pins upward on the H925 for easy access during system checkout.

The right side of the H925 is provided with three axial flow fans (300 cfm) which are mounted internally. They provide cooling air flow across the mounted modules.

For power supply mounting in the H925 cabinet, omit 4 connector blocks thereby deleting 32 module slots, when using the H800 or H803 connector blocks. If the H808 blocks are used, 16 module slots are deleted. Mount the power supply externally if all logic mounting space is required.

For ease of mounting, the H925 is provided with two non-tilting slides, similar to Grant type SS-168-NT. Considering possible servicing, the H925 should be mounted with enough height for using bottom access.

The H925 includes top and bottom cover plates along with an attractive bezel and front subpanel. The subpanel is made of sturdy 16-gauge metal for mounting front panel controls and accessories. The bezel is designed for installing a customer-supplied dress panel. The dress panel should have a thickness of  $\frac{1}{8}$ ". The H925 fits all DEC 19" racks.

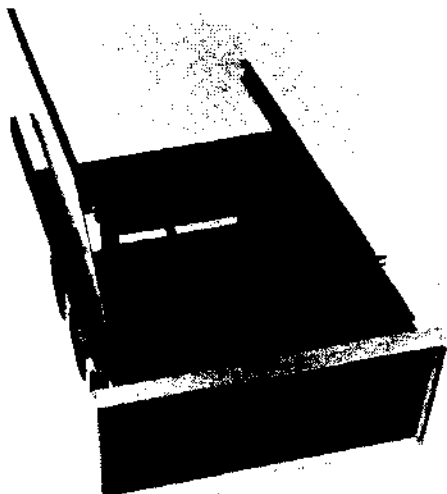

H925—\$250

**19" MOUNTING PANEL FRAME  
H941AA**

**UNIVERSAL  
HARDWARE**

This rugged steel frame holds four 19" x 5 $\frac{1}{4}$ " mounting panels. A quick-release pin snaps out to allow the two-piece frame to swing open for easy access to the back panel wiring and connections. The construction of this frame allows sufficient rigidity for vertical or horizontal mounting. The Black Tweed finished aluminum cover affords mechanical protection for the circuitry as well as a neatly finished appearance for your digital logic system. The cover attaches to the frame with two thumb-release, positive-grip fasteners.

The H941 AA holds up to 32 H800, H803 and H808 Connector Blocks. It provides up to 256 module slots with H800 and H803 Connector Blocks and 128 slots with the H808's. The frame is designed to accept K943, H911, H914, 1943 Module Panels and H900, H910, H913, H916, H917 panels with power supplies. These panels attach to the pre-tapped frame with 10-32 x  $\frac{1}{2}$ " machine screws.

Frame Height: 23"

Frame Width: 24"

Overall Depth (Cover and Frame): 8"

Frame Mounting Hole Centers: 12 x 22 $\frac{1}{2}$ "

Frame Mounting Bolt:  $\frac{3}{4}$ " dia.

Weight (Cover and Frame): Approx. 25 lbs.

Cover Material: .093" Sheet Aluminum

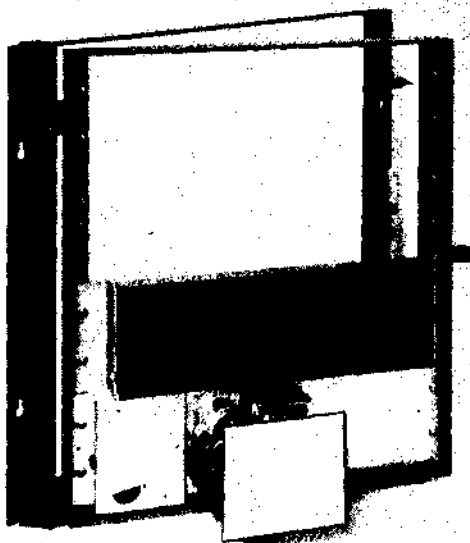



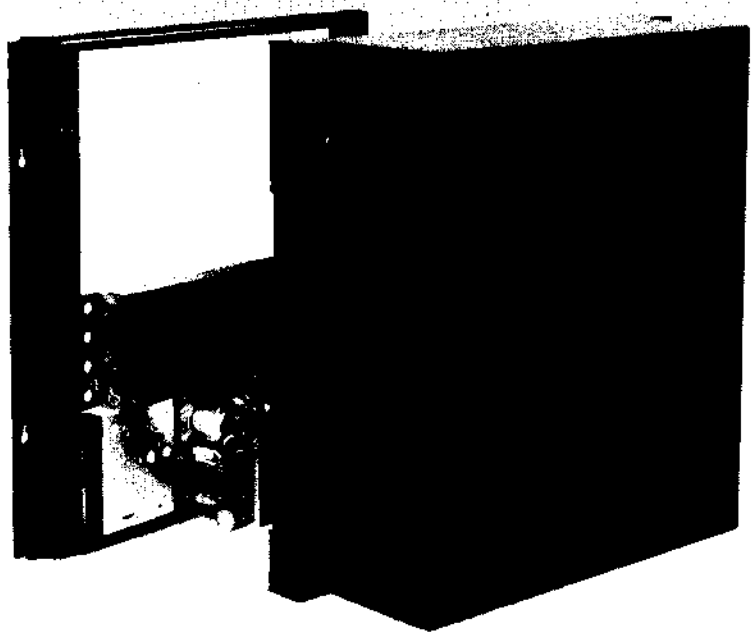

---

H941 BA, H941 AA  
Includes Cover and  
Two Piece Frame  
\$175.00

---

**CABINET  
H950**

**UNIVERSAL  
HARDWARE**

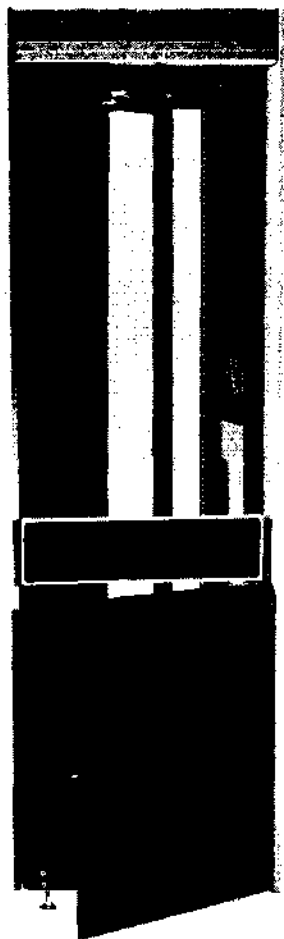

Front view of H950 frame.

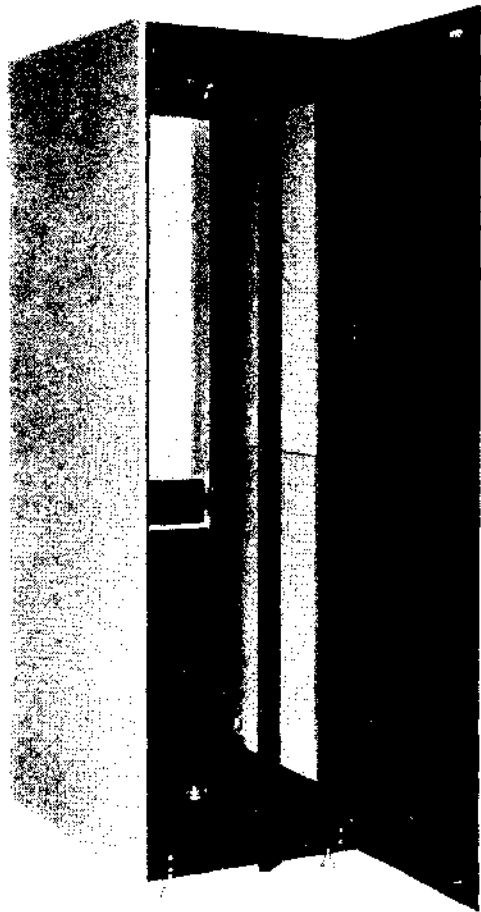

Rear view of H950 frame.

Digital Equipment Corporation manufactures a standard 19" mounting frame assembly that offers the customer complete flexibility in selecting hardware to design the cabinet. It is a complete enclosure designed to house module racks, power supplies, computer, systems, and peripherals.

The H950-AA frame assembly, which includes a filter cover, is designed for sophisticated computer systems. It is constructed of rugged 12 and 13 gauge steel. The two pairs of frame uprights have 9/32" holes drilled at standard EIA spacings ( $5/8$ — $5/8$ — $1/2$ ) the full length of the 63" mounting panel height.

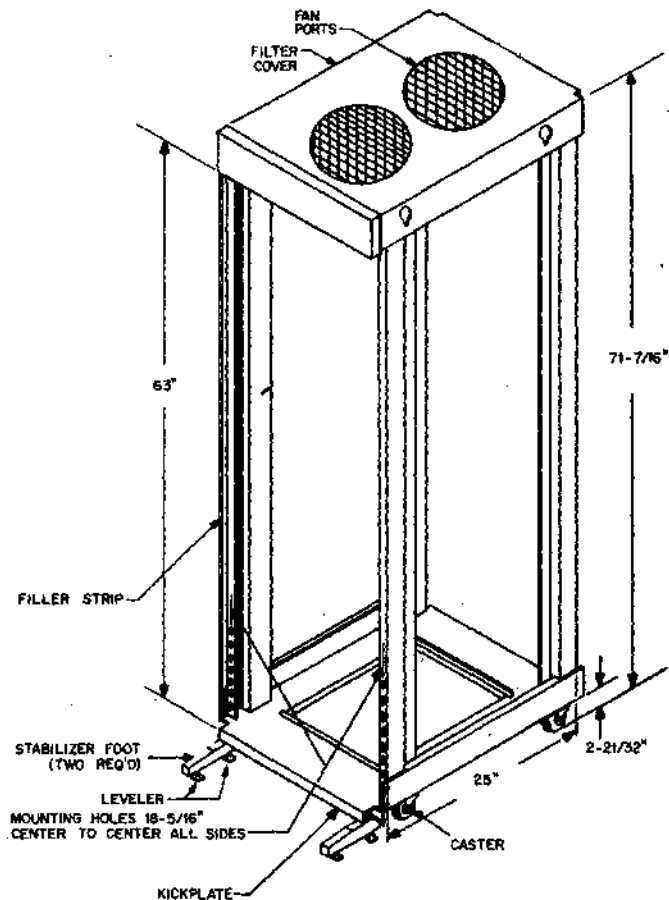

## OPTIONAL PARTS H950

## UNIVERSAL HARDWARE

1. The H952-EA caster set (4) and H952-FA leveler set (4) are needed for the H950 frame to provide mobility and balance to the cabinet.
2. The fan assembly H952-CA is mounted to the top pan of the H950-AA frame. When ordering, please specify the direction of air flow, up or down.
3. H952-AA end panels are standard gray and are easily mounted to the frame.
4. The frame identification panel (LOGO) H950-LT is available with colored adhesive inlay strips of brown/yellow or dark blue/light blue.
5. The H950-P or -Q bezel cover panel is available in heights of  $5\frac{1}{4}$ " and  $10\frac{1}{2}$ " with a 19" panel width. It is used as a cover panel or filler for the front of the cabinet. The customer can select any combination of bezels to fill the cabinets front panel space of 63".
6. The H950-HA through H950-HK series of short doors are available for mounting to the cabinet's front side. A various table of short doors is listed in the H950 parts list. The customer has the option of completing the front side of the cabinet with a combination of short doors and bezels. NOTE: Dimensions of doors listed only cover mounting panel height. Check special considerations section for short door limitations.
7. The H950-BA (right-hand door) and H-950-CA (left-hand door) are full doors for rear and front mounting to the H-950-AA frame. See special considerations section for front mounting.
8. The rear mounting panel door, also called a plenum door H950-DA or EA, is for left-hand or right-hand mounting. There is a distinct advantage to using the plenum door for mounting power supplies, logic racks, module connector block panels, etc. It offers convenient access for servicing and mounting equipment. It is designed for 19" panels and holes are drilled to  $9/32$ " at standard EIA spacings ( $\frac{5}{8}$ — $\frac{5}{8}$ — $\frac{1}{2}$ ) the full length of the plenum door frame. The customer has the option of selecting a rear mounting panel door skin H950-FA that bolts to the plenum door or ordering a full door. For additional information, see special consideration section.
9. The filter H950-SA should be ordered only for fans that are to be used for air flow intake.

### Special Considerations

Before ordering a cabinet, the following should be considered:

- 1) If a LOGO is used, only a short door can be used on the cabinet front.
- 2) When ordering a cabinet to add to a system, or when joining two or more cabinets, front and rear fillers H952-G are required.
- 3) If power supplies with meters or switches are mounted to the plenum door H950-DA (RH) or H950-EA (LH), a full door H950-DA (RH) H950-CA (LH) is needed.
- 4) The mounting panel door skin H950-FA bolts to the plenum door and is used in place of a full door when hardware mounted to the plenum door does not require servicing.
- 5) All cabinets require power supplies adapted for 19" rack mounting. 17" rack panels can be converted to 19" by using extenders. Up to five power supplies can be mounted on a side frame.
- 6) When ordering stabilizer feet, H952-BA (pair) and/or kickplate 7406782, a short door or full door cannot be used in the cabinet front.
- 7) If fan assembly H952-CA is required, indicate the direction of desired air flow (up or down).
- 8) If using short door, make certain that the equipment for cabinet installation will not interfere with the door height.
- 9) The inner dimensions of the H950-AA frame on all (4) sides are 18-5/16. Consequently, it offers flexible panel rack expansion.

### Ordering Format (Example)

When ordering H950 Hardware, use the following format:

- |                                |                |
|--------------------------------|----------------|
| 1. Frame 19" cabinet           | H950-AA 1 pc   |
| Full door—RH                   | H950-CA 1 pc   |
| 5½" bezel cover panel          | H950-P 5 pcs   |
| Fan assembly, air flow upwards | H952-CA 1 pc   |
| Caster set (4)                 | H952-EA 1 set  |
| Leveler set                    | H952-FA 1 set  |
| 2. Cabinet                     | ADD-ON CABINET |
| add the following:             |                |
| 5¼" bezel cover panel          | H950-P 4 pcs   |
| 10½" bezel cover panel         | H950-Q 2 pc    |

## CABINET PARTS LIST

Frame 19" wide, 25" deep, 63" mtg. panel includes cover filter and all mtg. hardware	Parts No. H950-AA
Full door (RH) Front & Rear Door Mounting	H950-BA
Full door (LH) Front & Rear Door Mounting	H950-CA
Mounting panel door (plenum) RH rear mounting	H950-DA
Mounting panel door (plenum) LH rear mounting	H950-EA
Mounting panel door skin	H950-FA
Short door (covers 21" mounting height)	H950-HA
Short door (covers 22 <sup>3</sup> / <sub>4</sub> " mounting height)	H950-HB
Short door (covers 26 <sup>1</sup> / <sub>4</sub> " mounting height)	H950-HC
Short door (covers 31 <sup>1</sup> / <sub>2</sub> " mounting height)	H950-HD
Short door (covers 36 <sup>3</sup> / <sub>4</sub> " mounting height)	H950-HE
Short door (covers 42" mounting height)	H950-HF
Short door (covers 47 <sup>1</sup> / <sub>4</sub> " mounting height)	H950-HG
Short door (covers 52 <sup>1</sup> / <sub>2</sub> " mounting height)	H950-HH
Short door (covers 57 <sup>3</sup> / <sub>4</sub> " mounting height)	H950-HJ
Short door (covers 63" mounting height)	H950-HK
Frame panel (includes LOGO)	H950-LA
5 <sup>1</sup> / <sub>4</sub> " bezel cover panel (snap-on)	H950-P
10 <sup>1</sup> / <sub>2</sub> " bezel cover panel (snap-on)	H950-Q
Filter (for fan assembly)	H950-SA
End panel (require 2 per cabinet)	H952-AA
Stabilizer feet (pair)	H952-BA
Fan assembly (specify direction of airflow)	H952-CA
Caster set (4)	H952-EA
Leveler set (4)	H952-FA
Filler strip—front & rear (joining two cabinets)	H952-GA
Kick plate	7406782
Kick plate (use with Add On cabinet)	7406793

## ADD-ON OPTION CABINET

UNIVERSAL  
HARDWARE

The Add-on option cabinet uses the same H950-AA frame and parts as listed in the H950 and H952 parts list. It is designed for customers who want to add on to a basic cabinet system. It will house peripheral equipment for 19" panel rack mounting, especially those manufactured by DEC. Among the mounting options are 4K and 8K memory expansions, multiplexers, magnetic tape control transports, disk files, analog-to-digital converters, module racks, and power supplies. The cabinet is supplied without end panels, H952-AA, since the cabinet joins an existing basic system. The filler strip, H952-GA front and rear, are I-beams designed for compatibility between two or more cabinets.

The front part of the Add-on cabinet is equipped with a kick plate. The customer must remove the kick plate if a short door is to be used. The customer must specify what combination of bezels and/or short doors is needed to complete the front of cabinet. All parts are additional to quoted net price of the Add-on cabinet.

The Add-on cabinet includes all of the following:

	Part No.
Frame—19" wide, 63" mtg. panel height includes filter cover (less filter)	H950-AA
Mounting panel door skin	H950-FA
Mounting panel door (plenum)	H952-EA
Fan assembly — airflow upwards	H952-CA
Caster set (4)	H952-EA
Panel frame (includes LOGO)	H950-LA
Kick plate (to be used w/o stabilizer feet)	7406793
Filler strip front and rear (only used when joining cabinets)	H952-GA
Levelers	H952-FA

## **Ordering**

In order to efficiently assist the customer, we recommend that the customer specify the type of equipment intended for cabinets. Give the dimensions whenever possible to ensure exact cabinet configurations.

Before ordering hardware options for existing cabinets, make certain that they are compatible with the H950-AA standard frame, (overall height 71-7/16" from floor including casters, 19" wide frame, and 63" of vertical panel space). Module Marketing Services of Digital Equipment Corporation will assume responsibility only for parts ordered from the H950 and H952 Parts List.

## **Color**

Basic color of cabinet hardware is black. Gray is used for end panels and the bezel of the cover panels.

Color changes will be accepted if customer's order is for 25 or more cabinets. Customer must supply color chips for colors desired.

## **Shipping**

All shipments are FOB Maynard, Massachusetts. Specifications are subject to change without notice. Special packaging has been designed to ensure safe delivery with proper handling.

## **Assembly**

The customer has the choice of cabinet configuration as listed in H950 and H952 Parts List. The customer must indicate whether the cabinet parts are to be shipped unassembled or completely assembled by Digital Equipment Corporation. See special consideration section.

## **Discounts**

Same discounts that are applied to Modules. See Price List.

## **COLOR CHANGES**

Standard color of cabinets is black with gray end panels.

Customized painting will be accepted with a minimum order of 25 cabinets. Customer must supply a color chip for color desired. An additional charge of \$20.00 will be added for each cabinet painted.

Order should be sent to Module Marketing Services.

No cabinet hardware will be accepted for credit or exchange without the prior written approval of DEC, plus proper return authorization number (RA#).

All shipments are FOB Maynard, Massachusetts, and prices do not include state or local taxes. Prices, discounts, and specifications are subject to change without notice.

## **Quantity Discounts (Module Discount applies)**

\$ 5,000 — 3%	\$ 100,000 — 18%
10,000 — 5%	250,000 — 21%
20,000 — 10%	500,000 — 22%
50,000 — 15%	1,000,000 — 25%



## CABINET PRICE LIST MODULE PRODUCTS

Catalog No.	Description	Price
H-920	Module Drawer	\$170.00
H-921	Front Panel	10.00
H-923	Chassis Slides	75.00
H-925	Module Drawer	250.00
H-950-AA	Frame	152.00
H-950-BA	Full Door (RH)	31.00
H-950-CA	Full Door (LH)	31.00
H-950-DA	Mtg Panel Door (RH)	30.00
H-950-EA	Mtg Panel Door (LH)	30.00
H-950-FA	Mtg Panel Door Skin	21.00
H-950-HA	Short Door (Covers 21" Mtg)	57.00
H-950-HB	Short Door (Covers 22 <sup>3</sup> / <sub>4</sub> " Mtg)	57.00
H-950-HC	Short Door (Covers 26 <sup>1</sup> / <sub>4</sub> " Mtg)	57.00
H-950-HD	Short Door (Covers 31 <sup>1</sup> / <sub>2</sub> " Mtg)	57.00
H-950-HE	Short Door (Covers 36 <sup>3</sup> / <sub>4</sub> " Mtg)	57.00
H-950-HF	Short Door (Covers 42" Mtg)	57.00
H-950-HG	Short Door (Covers 47 <sup>1</sup> / <sub>4</sub> " Mtg)	63.50
H-950-HH	Short Door (Covers 52 <sup>1</sup> / <sub>2</sub> " Mtg)	63.50
H-950-HJ	Short Door (Covers 57 <sup>3</sup> / <sub>4</sub> " Mtg)	63.50
H-950-HK	Short Door (Covers 63" Mtg)	63.50
H-950-LA	Frame Panel (includes Logo)	16.00
H-950-P	5 <sup>1</sup> / <sub>4</sub> " Bezel Cover Panel	10.00
H-950-Q	10 <sup>1</sup> / <sub>2</sub> " Bezel Cover Panel	12.00
H-950-SA	Filter (for Fan Assembly)	4.00
H-952-AA	End Panel (2 per cab)	39.00
H-952-BA	Stabilizer feet (pair)	25.50
H-952-CA	Fan Assembly (specify air flow)	54.50
H-952-EA	Caster Set (4)	14.50
H-952-FA	Leveler Set (4)	12.50
H-952-GA	Filler Strip F & R (joining two cabinets).	44.00
7406782	Kickplate	4.00
7406793	Kickplate (for use w/o Stabilizer Feet)	5.50
Add on Cabinet Unassembled		350.00
Add on Cabinet Assembled		400.00

**NOTE:** Cabinets are shipped unassembled. For cabinet assembly a \$50.00 charge will be added.

**ORDERING INFORMATION  
FOR  
PREASSEMBLED CABLE**

**UNIVERSAL  
HARDWARE**

Standard lengths for preassembled cable are: 3, 5, 7, 10, 15 and 25 feet.

Cable price per foot is as follows:

19 conductor Ribbon cable	\$0.60
9 conductor Flat Coaxial cable	\$1.00

Standard charges for connection of cable to each connector is as follows:

Ribbon	\$ 9.00 per connector side
Coaxial	\$18.00 per connector side

**STANDARD PREASSEMBLED CABLES**

RIBBON			COAXIAL		
Type	CONNECTORS	Basic Price	Type	CONNECTORS	Basic Price
BC02L-XX	W021-W021	\$26.00	BC03C-XX	W021-W021	44.00
BC02S-XX	W023-W023	\$26.00	BC03D-XX	W021-W022	45.00
BC02N-XX	W028-W021	\$26.00			

To the above prices, add price of cable:

Example: BC02L-7                      \$30.20

1—BC02L-XX	\$26.00
7 feet ribbon cable @ \$0.60/ft.	4.20
	<u>\$30.20</u>

**MODULE EXTENDER**  
W980

**UNIVERSAL  
ACCESSORIES**

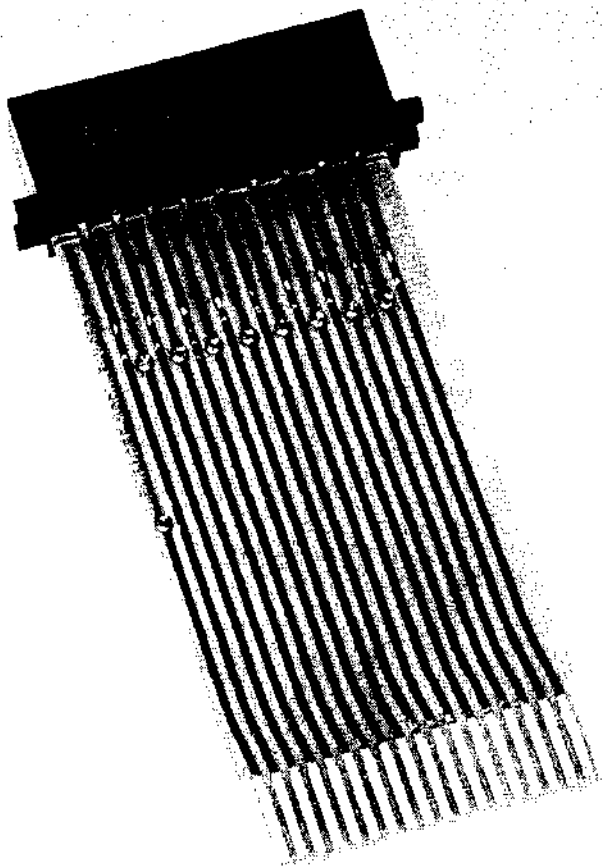

The W980 Module Extender allows access to the module circuits without breaking connections between the module and mounting panel wiring.

For double size flip-chip modules use two W980 extenders side by side. The W980 is for use with A, K and W Series 18 pin modules.

---

W980 — \$14

---

**MODULE EXTENDER  
W982**

**UNIVERSAL  
ACCESSORIES**

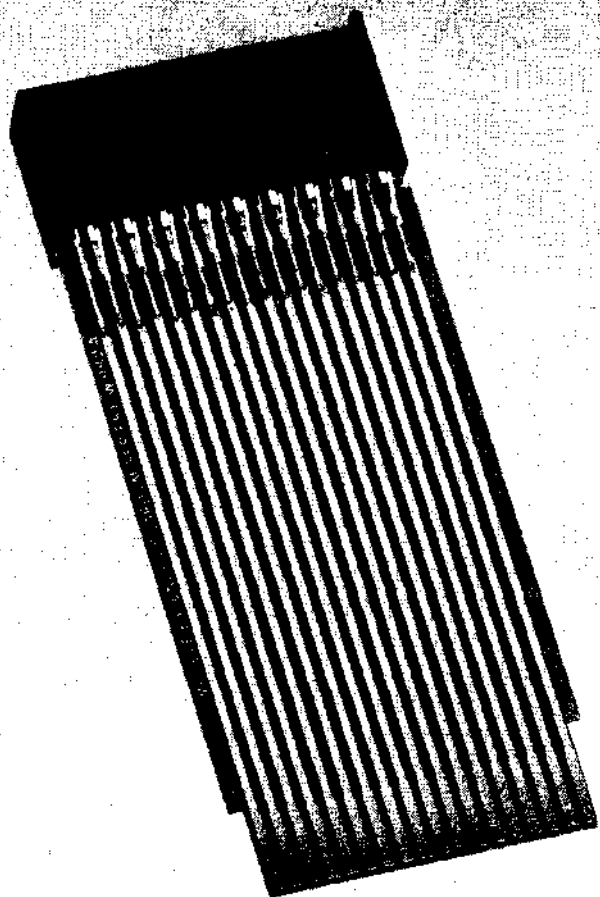

The W982 serves a function similar to the W980 except it contains 36 pins for use with M series modules. The W982 can be used with all modules in this catalog. A, K, and W series modules will make contact with only 2 side pins. A2, B2, etc.

For double size M Series modules use two W982 extenders side by side.

---

W982 — \$18

---

# BLANK MODULES

## W970-W975, W990-W999

# UNIVERSAL HARDWARE

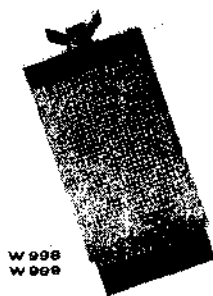
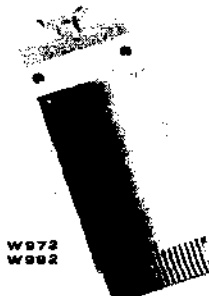
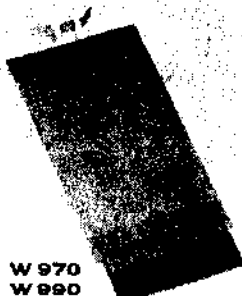

These 10 blank modules offer convenient means of integrating special circuits and even small mechanical components into a FLIP CHIP system, without loss of modularity. Both single- and double-size boards are supplied with contact area etched and gold plated. The W990 Series modules provide connector pins on only one module side for use with H800 connector blocks. W970 series modules have etched contacts on both sides of the module for use with double density connectors Type H804, and low density Type H808.

Type	Height	Pins	Description	Handle	Price
W990	Single	18	Bare board, split-lug terminals	attached	\$ 2.50
W991	Double	36	Bare board, split-lug terminals	attached	\$ 5.00
W992	Single	18	Copper clad, to be etched by user	separate	\$ 2.00
W993	Double	36	Copper clad, to be etched by user	separate	\$ 4.00
W998	Single	18	Perforated, 0.052" holes, 18 with etched lands. The holes are on 0.1" centers, both horizontally and vertically.	attached	\$ 4.50
W999	Double	36	Perforated, 0.052" holes, 36 with etched lands. The holes are on 0.1" centers, both horizontally and vertically.	attached	\$ 9.00
W970	Single	36	Bare board, no split lugs, similar to W990, contact both sides	attached	\$ 4.00
W971	Double	72	Bare board, no split lugs, similar to W991, contact both sides	attached	\$ 8.00
W972	Single	36	Copper clad both sides similar to W992	separate	\$ 4.00
W973	Double	72	Copper clad both sides similar to W993	separate	\$ 6.00
W974	Single	36	same as W998, contact both sides	attached	\$ 9.00
W975	Double	72	same as W999, contact both sides	attached	\$18.00

Old boards with .067" holes on .2" centers are no longer available.

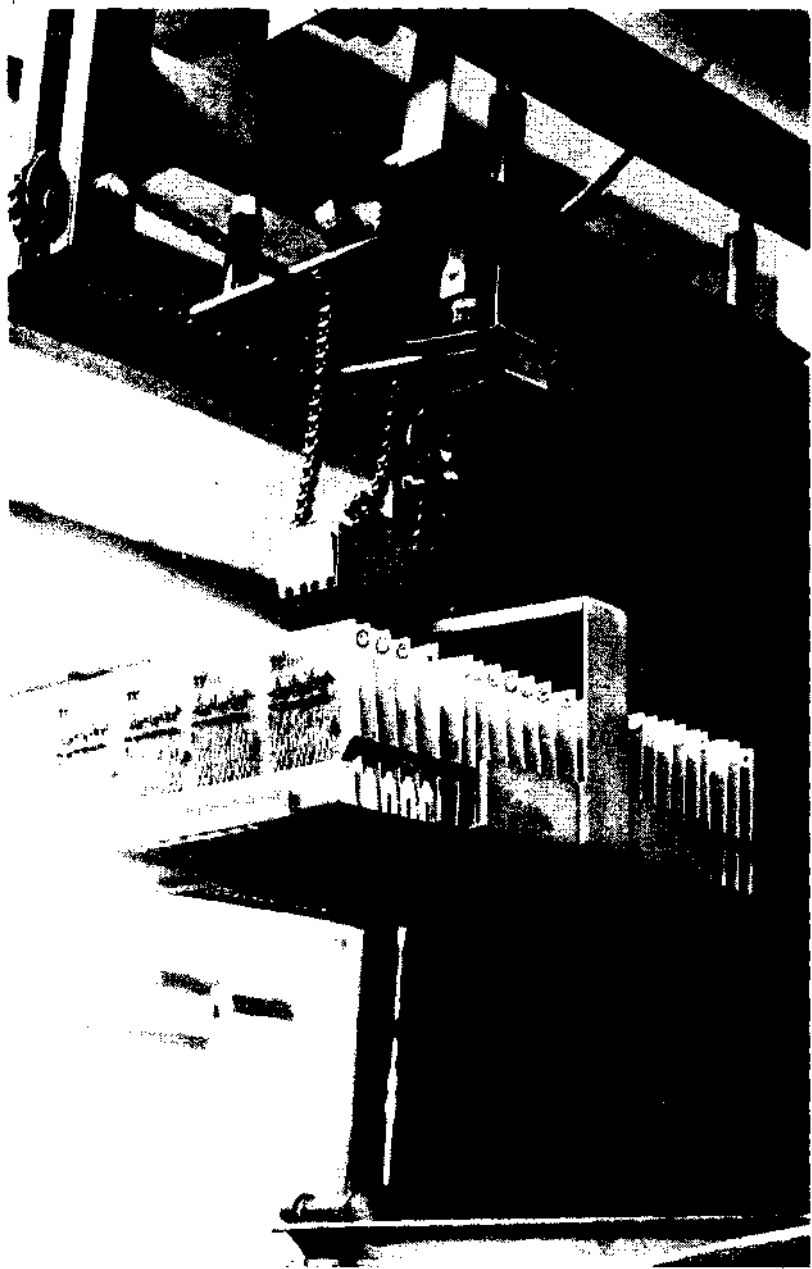

After all the components have been attached to the board, the module is degreased to remove contaminants in preparation for flow soldering.

## K Series Applications

The engineering of K Series would be for naught if it couldn't be applied practically. The following section shows but a handful of uses for which K Series has been designed. Practically all of those presented were designed by DIGITAL's module application group which provides design assistance to our customers. More than 300 logic systems for control and interfacing have been designed by this group. These include designs of: simple interfacing between a computer and stepping motors; controls for injection molding machines; plating machine controls; transfer machine controls; materials sensing and classification systems; pipeline flow counters; camera shutter controls; computer interfacing to observatory telescopes; and a woodcutting machinery controller. Many of the control applications have been conversions from relays to K Series.

There is an excellent likelihood that our engineers have designed a control system for equipment just like yours. If not we would like to give it a try.

## K-SERIES CONSTRUCTION RECOMMENDATIONS

A high percentage of all failures in electronic systems result directly from hasty planning of nonelectronic aspects. Much time and trouble can be saved by planning mechanical assembly before construction begins. Wiring methods and lead dress, heat distribution and temperature control, power supply reliability and line fault contingencies, and the attitudes and habits of people working near the system all merit forethought. Important opportunities for reliability, maintainability, and convenience will be lost if early and consistent attention is not given the topics below.

### Environment

#### a. Temperature

Module temperature ratings are  $-20^{\circ}\text{C}$  to  $65^{\circ}\text{C}$  ( $0^{\circ}\text{F}$  to  $150^{\circ}\text{F}$ ) except K201, K202, K210, K211, K220, K230, and K596 which are limited to  $0^{\circ}\text{C}$  ( $36^{\circ}\text{F}$ ) minimum. These ratings are for average air temperature at the printed board, and take local heating by high dissipation components into account. Free, unobstructed air convection is required for reliable operation; the plane of each module must be essentially vertical for this reason.

Convection is required not only to remove heat but also to distribute it, and movable louvres or baffles used to obtain self-heating under frigid conditions must not interfere with air movement within and around modules.

#### b. Motion

Transport or use in trucks or aboard ships can vibrate modules sufficiently to work them out of their sockets. K271, K273, K604, K644, K731, K732, K303, K301 and K323 modules with K374 or similar controls attached are most subject to disturbance.

If modules are mounted in a K943 19-inch panel, use K980 endplates and a 1907 cover.

If modules are mounted on the hinged door of an enclosure, position the K941 so a support bolted to the side of the enclosure will contact the modules when the door is closed, taking care not to let the support interfere with ribbon cable on K508, K524, K604, and K644.

Mercury contact relays in K273 modules should be maintained within  $30^{\circ}$  of vertical while operating to insure correct logic output.

Controls such as K374, etc. will hold their setting in vibration, but are easily disturbed by repeated contact with loose wiring, etc.

Finally, take pains not to nick logic wires if vibration is likely to be encountered. Use a quality wire stripper. One of the new motor driven rotary types could easily pay for itself by reducing wiring time and avoiding vibration induced wire breakage.

#### c. Contaminants

Sulphurous fumes will attack exposed copper or silver; their presence demands the coating of ribbon connections and K731 heatsink cladding with suitable insulating varnish or plastic. A combination of high humidity and



contaminated atmospheres requires such treatment on all printed wiring of K301, K323, and K303 timers and controls, since at maximum settings even a few microamperes of leakage will affect their timing. Varnish or coatings are neither required nor recommended in less hostile conditions, and in any case it is desirable to exclude contaminants.

#### **d. Convenience**

Adjustments should be mounted so the least critical are easiest to reach. Calibrated controls such as K374, etc. should be positioned in a logical pattern before K303 sockets are wired. Ruggedness and feel should govern the selection of remote timer controls likely to be operated in moments of preoccupation or alarm.

Pluggable connections to K716, K724-K725, and (optionally) to K782-K784 allow electricians to complete their work while the logic itself is being built or checked elsewhere. Plan cable routing to simplify installation of electronics last. Take advantage of the ease with which a K941 mounting bar can be fastened to a pre-installed K940 foot.

### **Logic Wiring**

#### **a. General Information**

Wire wrapping is the most suitable technique for the sockets used with K series modules. Some prefer AMP Termi-Point (trademark) but neither AMP nor DEC can guarantee full compatibility for this system. Solder fork connectors are optional; wrapped connections may also be soldered. For large volume repetitive systems using K943 mounting panels, DEC offers a machine-wrapping service.

Never solder or wire wrap with any tool if there are modules installed, unless the tool is grounded to the frame to drain static charges, and unless AC operated devices work from isolation transformers. It is safest to avoid AC operated wire wrap tools together. Hand-operated pistol-grip wire wrapping tools are surprisingly efficient and easy to use. If automatic machine wrapping is contemplated, plan for only two wraps per pin.

#### **b. Wire Types**

Teflon (trademark) insulation over size 22 tinned solid copper wire is best for soldering. Size 24 tinned solid copper wire must be used for wrapping H800 and K943 pins. Teflon (trademark) insulation may be used, but some prefer to sacrifice high temperature performance by using Kynar (trademark), to get greater resistance to cut-through where soldering is not involved.

Type 932 bussing strip allows module power and ground pins A and C to be connected conveniently, and is also helpful if several modules have common pin connections.

#### **c. Procedures**

First solder in all bussing strips. Next tie all grounds and grounded pins together. Finally point-to-point wire all other connections.

Run all wires diagonally or vertically. Do not run wires horizontally except to adjacent pins or along mounting bar between modules. Horizontal zig-zag wiring interferes with checking and is prone to insulation cut-through. Leave wires a bit slack so they can be pushed aside for probing. Cabling is definitely not recommended. Wires should be more or less evenly distributed over the wiring area.

When wrapping, avoid chains of top-wrap-to-bottom-wrap sequences which entail numerous unwrappings if changes must be made. Properly sequenced wraps require no more than three wires to be replaced for any one change in two-wraps-per-pin systems. Never re-wrap any wire. For best reliability, do not bend or stress wrapped pins, for this may break some of the cold welds. Follow tool supplier's recommendations on tool gauging and maintenance etc. As a convenience, DEC stocks three Gardener-Denver tools under numbers H810, H811, and H812. See specifications pages.

## **Field Wiring**

### **a. AC Pilot Circuits**

All screw terminals used in the K-Series have clamps so that wires do not need any further treatment after insulation is stripped. All terminals can take either one or two wires up to 14 gauge.

K716 terminals have been arranged so AC inputs all go to one end of the interface block, and AC outputs all go to the other end. The eight terminals nearest the center are typically connected only to each other and to a few return and AC supply wires. Input and output leads should be segregated so they do not block entry to the ribbon connector sockets. If sockets face to the left, AC inputs will be above and all other connections below. Wires should be routed down the connector side of K716 blocks to cable clamps or wiring ducts placed parallel with K716s. (See diagrams on K716 data page.) Plan the logical arrangement of field wiring terminals and indicators before module locations are selected to avoid excessive folding or twisting of ribbon cables. (See recommendations on module locations below.)

### **b. DC and Transducer circuits**

DC outputs from K644, K656, K681, and K683 and AC outputs from K604 and K614 are high level; wiring is noncritical. Low level inputs, however, may require special treatment to avoid false indications. Low level signals should at least be isolated from AC line and DC output signals throughout the field wiring system, and, as a minimum, individual twisted pairs should be used for signals and return connections.

For lower signal levels or longer wiring runs, shielded pairs may be required, with the shield grounded only at one point, preferably at the logic system end unless one side of the transducer is unavoidably grounded. Conduit which may be grounded indiscriminately is not an effective substitute for shielded, insulated wiring.

All signals except line voltage AC inputs use the straight-through connections of K716 terminals 15 through 24. Within the K716, leads are shortest to terminals 15, 17, 18, 19, and 20; use these terminals for minimum noise on K524 low level signals.

Module types K578, K614, K615, K650, K652, K656, and K658 have their own terminal strips and do not require the use of a K716. Modules that do not have terminal strips may be connected to field wiring through the K782 or K784 module.

## **Module Locations**

### **a. End Sockets (K941)**

The first sockets to assign are those for K731 and K732 regulators, and for K301, K323, and K303 timers. If possible, mount regulators nearest the foot of a K941 mounting bar, so their extra bulk projects into the space between the mounting surface and the first H800 block on the bar. Controls mounted on the same mounting surface opposite K731 source modules may be as much as  $\frac{5}{8}$ " deep without touching modules.

Sockets at the outer end of K941 mounting bars are the only locations where K303 timers can have integral controls mounted. Even where the use of K370-group controls is not initially planned, assignment of K303 modules to these outer locations is recommended. Also, these sockets should be the first reserved as spares if any unused locations are available. This way maximum flexibility will be preserved for possible design changes or additions.

### **b. Interface Modules**

AC and DC interface modules such as K508, K524, K604, and K644 should be assigned locations that simplify cabling. Ribbon cables can be twisted by a succession of 45° folds, but a neat installation should be planned. Assign the location and position of K716 interface blocks first. Consider such features as logical arrangement of indicator lights for trouble shooting, ease of routing and tracing field wiring, and directness and length of ribbon cable runs back to the logic modules.

After K716 locations and assignments have been selected, assign socket positions for interface modules (K508, etc.). The order should be coordinated so the combined ribbon cables will lie flat together. Excess ribbon cable can be easily and neatly folded away. Lengths other than 30" are not available since these modules cannot be tested and stocked until cables are cut and soldered. This should cause no difficulty if module locations are assigned thoughtfully.

### **c. Display Modules**

If K671 decade displays are required, select their locations after regulator and interface modules have been assigned sockets. The 12" cables on these modules are oriented for convenient assembly of displays above logic modules, to be viewed from outside the door or enclosure in which K940 and K941 hardware is mounted. Used this way, the digits of lower significance have cables below those of more significant digits.

For neatest cabling and quickest module wiring, counter and display modules should be arranged so the counter input will be nearest the K940 mounting surface. Notice that pin connections on K671, K210, and K220, and K230 modules are coordinated, so that a side-by-side pairing of flip-flop and associated K671 modules will result in short, neat, easy wiring. Ribbon cable passes easily between modules, so it is not necessary to restrict K671 modules to the topmost row. However, the limited cable length will usually restrict them to the top mounting bar in systems using more than one K941.

Do not fold or arrange ribbon cables so that they lie flat on the upper edges of modules, as this will restrict the flow of cooling air.

## **System Power**

### **a. Supply Transformer**

Any filament or "control" transformer rated at 12 v or 12.6 v RMS on nominal 120 v line voltage may be used to supply power to K series logic. However, use of a 12 v instead of a 12.6 v transformer reduces maximum current ratings from K731 and K732 by 15%, as does a 5% voltage drop from any other cause such as resistance in secondary wiring or line voltage below the nominal 10% tolerance.

Transformer current rating should be for capacitor-input filter, about 50% higher than the rating required for resistive loads. Thus a single K731 1 amp regulator requires a center-tapped transformer with  $\frac{3}{4}$  ampere rating on resistive loads at 12.6v, or with two 6.3v windings rated  $\frac{3}{4}$  ampere each.

These transformer selection considerations can of course be eliminated by using K741 or K743 transformers with noise filtering built-in.

### **b. Noise Filtering**

Hash filter capacitors of 0.1 mf each are recommended from each side of the power transformer secondary to chassis ground. In environments where the AC line may carry unusually large amounts of noise, line filters such as Sprague Filterols (trademark) are advisable. K series systems must not share 12 volt power with any electromechanical device, since the transformer itself is the primary filter for medium-frequency line noise rejection.

### **c. Power Wiring**

In systems not requiring full use of the quick-change features of the K716 and K940, transformer secondaries can be wired directly to pins U and V of regulator modules. If power connections are to be removed with maximum speed, a W021 connector board may be used to bring 12 VAC power into the system. It is best to limit current through any pin to about 2 amperes, so in large systems several W021 pins are needed for each side of the secondary.

### **d. Alternate Power Supplies**

Any source of 5 VDC  $\pm$  10% may be used for K series systems at ordinary room temperatures, provided noise, hash, spikes, turnon-overshoot, etc. are reasonably well controlled. K series modules are far less sensitive to noise on power lines than computer-speed circuits, but it is still possible to cause malfunction or damage if extreme noise is present.

Temperature coefficient of the K731 regulator is selected to compensate for that of timers and other circuits, so operation over temperature extremes with constant-voltage supplies involves a sacrifice in timing consistency. Output fanouts are also degraded if constant voltage supplies are used at extreme low temperatures. Derate linearly from 15 ma at room temperature to 12 ma at  $-20^{\circ}\text{C}$  ( $0^{\circ}\text{F}$ ) for constant-voltage power supplies.

### **e. Line Failure**

When unscheduled shutdown of a K-series system cannot be tolerated in spite of AC power failure, some form of local energy storage is required. To withstand short-term failures it is possible to add extra capacitance from pin A to pin C. However, manual grounding of pin D (turnon level) may be re-

quired to start the system, since the external capacitance will appear to the regulator as a short and output current will be limited to a low value. For each ampere millisecond of dc power storage beyond the rise of K731 OK level, 10,000 mfd is required. The supply itself provides one half ampere-millisecond internally. K732 slave regulators each provide one ampere-millisecond internally. However, these survival times are only available when regulators are operating at or below 75% of their nominal ratings.

A 5 volt battery, or a 6 volt battery with series diode(s) to drop the voltage to 5 volts, may be used as an alternate source of power in case of line voltage failure. In very small systems (with some types of batteries) it may be practical to use the battery itself as a shunt regulator, charging it through a simple full-wave rectifier and dropping resistor circuit from the same kind of transformer used with K-series regulators. Unless the current is very low with respect to battery size, however, some means of switching the battery connection will be required. Below is shown a circuit which can be used for current requirements to 1 ampere. The same principle can be extended to larger systems with slightly more complex circuitry.

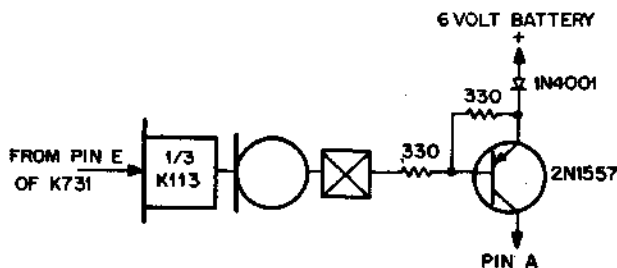

**POWER FAILURE SWITCH FOR EMERGENCY BATTERY**

## CONVERSION OF RELAY CIRCUITS TO K SERIES

Conversion of relay logic to K Series is a simple and straight-forward procedure. The design of a solid state control system using three basic functions—AND, OR and NOT—is performed the same as with relays. Thus the problem of converting a given relay circuit to K Series may be broken down into two simple steps. First, derive from the relay circuit a set of logical equations using standard logical notation describing the operation of the circuit. Second, from these logical equations, design a K Series circuit to perform the desired logical function.

### Relay Logic

Consider the following circuit:

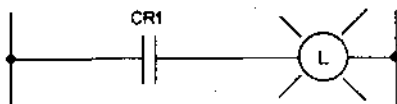

The light only comes on when relay contact CR1 is closed (when the relay is on). So if the letter L represents the light and CR1 represents the relay, we can write the logic equation for this circuit as  $L = CR1$ . When CR1 is off (false), then L is off (false) and vice versa.

### Relay NOT

Consider the following circuit:

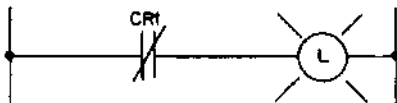

In this circuit, the light is on when the relay is off, and the light is off when the relay is on. This is just the NOT function, so we can write the logic equation  $L = \overline{CR1}$ .

## Relay AND

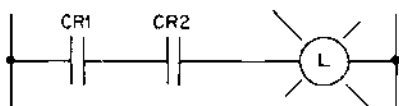

In this circuit, the light is on only when both CR1, and CR2 are closed. This is just the AND function and can be written

$$L = CR1 \cdot CR2$$

## Relay OR

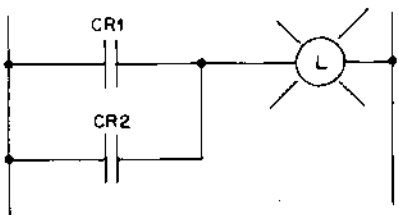

In this circuit, the light is on when either or both contacts CR1, CR2 are closed. This is the OR function  $L = CR1 + CR2$ .

## K Series Logic

K Series logic performs the same functions that we have seen relays perform.

### AND

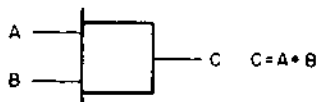

### OR

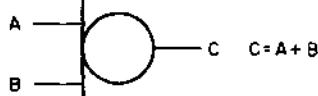

### NOT



If we were to replace pairs of relay contacts with K Series logic we would get the following:

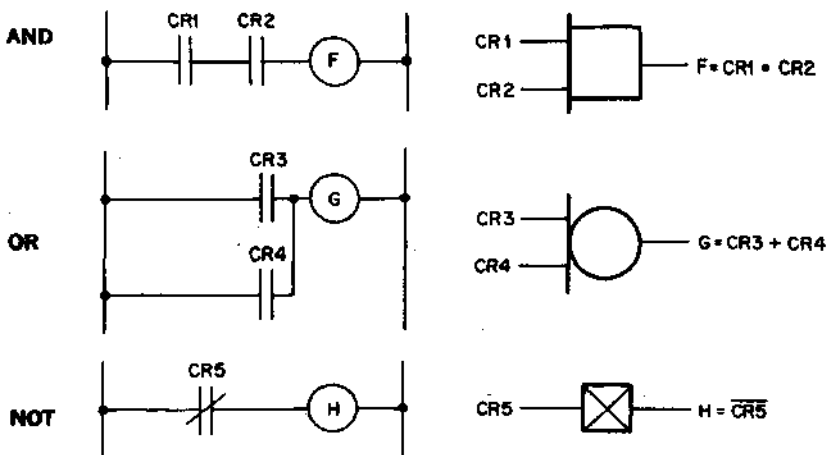

### Combined Logic

Often, several basic logic functions occur together to form a more complex function.

For example:

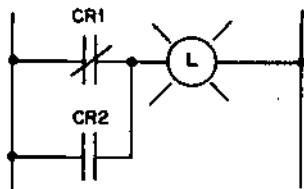

Has the equation  $L = \overline{CR1} + CR2$   
Which in the K Series logic would be



Or, for example:

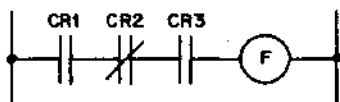

Has the equation  $F = CR1 \cdot \overline{CR2} \cdot CR3$



## Writing Logic Equations

As noted so far, in writing down the logic equation from logic each relay contact is assigned a name, which appears as a variable in the equation, as shown below.

Relay logic

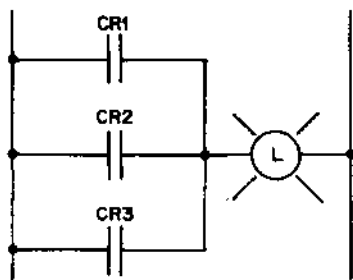

$$\text{Equation } L = CR1 + CR2 + CR3$$

Writing the equation of more complex sets of relay contacts is simply a matter of picking out the basic functions one at a time.

For example:

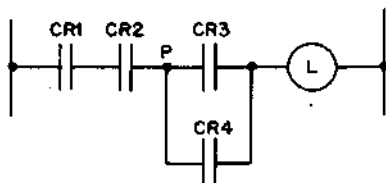

Notice that CR1, CR2 perform the AND function, so  $P = CR1 \cdot CR2$ .

The diagram could be redrawn as follows:

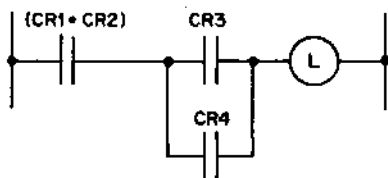

Because CR3, CR4 now perform the OR function, the diagram can be redrawn as follows:

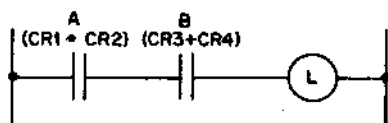

The two remaining "contacts" perform the AND function, therefore the logic equation can be written:

$$L = A \cdot B \text{ and } A = CR1 \cdot CR2 \text{ and } B = CR3 + CR4$$

$$\text{therefore } L = (CR1 \cdot CR2) \cdot (CR3 + CR4)$$

Another example:

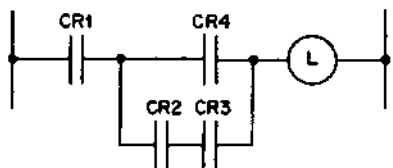

First, CR2, CR3 form the AND function resulting in

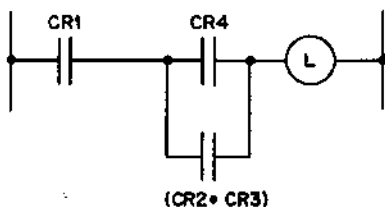

Subsequently (CR2 • CR3), CR4 form the OR function resulting in

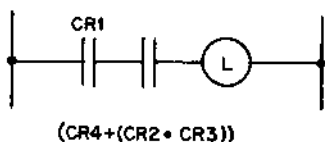

Finally, C1, (CR4 + (CR2 • CR3)) form the AND function so  $L = CR1 \cdot (CR4 + (CR2 \cdot CR3))$ .

### Converting logic equation to K Series logic

The object in converting logic equations to K Series logic, is to devise a K Series logic network which has the same logic equation as the relay logic.

For example, the equation  $F = (A \cdot B) + C$  can be implemented with K Series logic as follows:

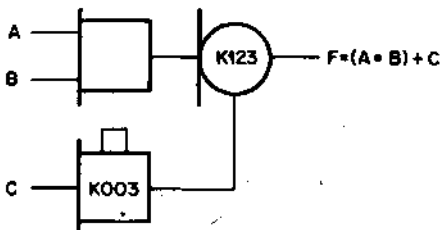

Or, for example, the equation  $F = (A + B + C) + (D \cdot E)$  becomes:

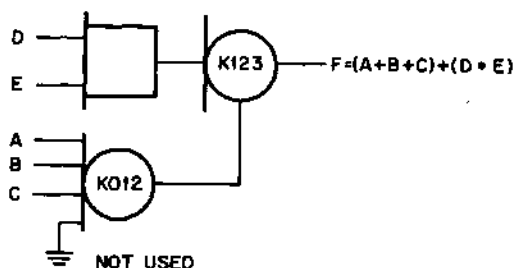

Most logic equations can be implemented with K Series logic in a number of ways. For example, the equation  $F = \bar{A} + (B \cdot C)$  may be realized correctly by either of the designs shown here.

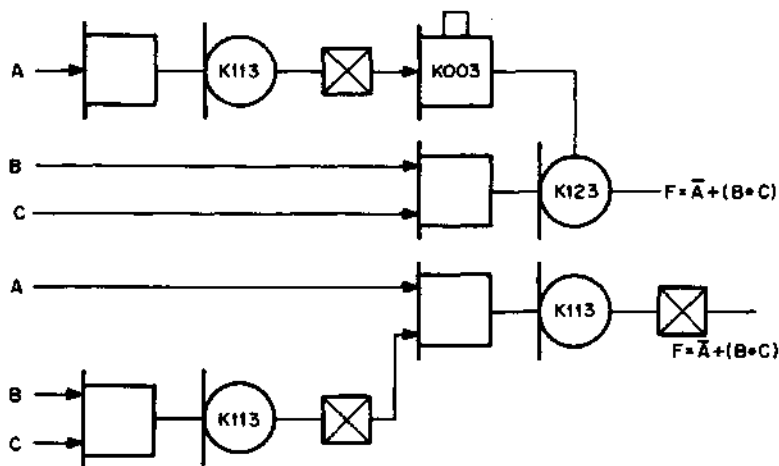

In general, when alternate means of implementing a function are available, the decision as to which one to use is often based on which K Series gates are available, on which alternative is more economical, or oftentimes on the designer's personal preferences.

Unfortunately, there is no single route to follow to arrive at a K Series logic design from the logical equation. As in most design situations, the imagination and intuition of the designer are prime factors in arriving at a solution. Therefore, once the basic operation of K Series logic becomes familiar, a few hours of experimenting with the K Series Logic Lab can provide a much deeper understanding of how to use K Series.

On the following pages, a number of examples are shown of relay circuits which have been converted into logic equations and then implemented with K Series logic.

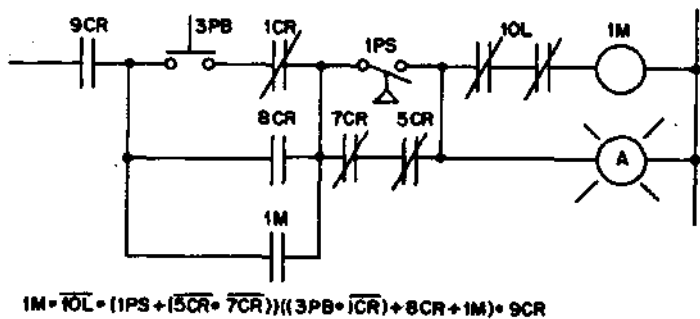
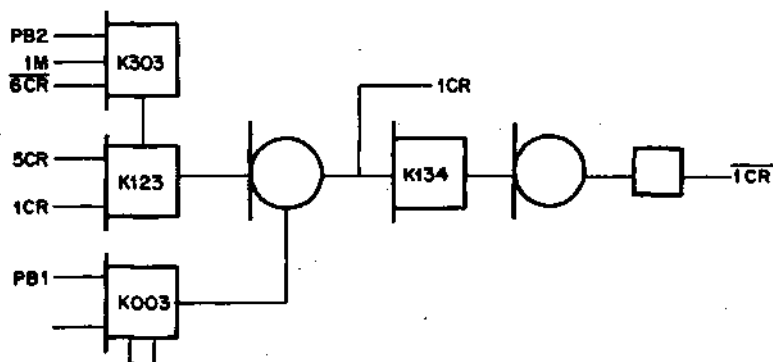
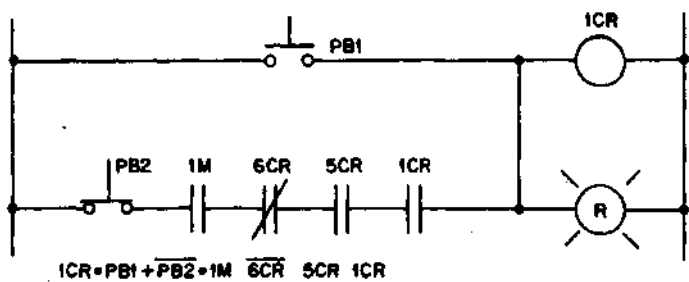

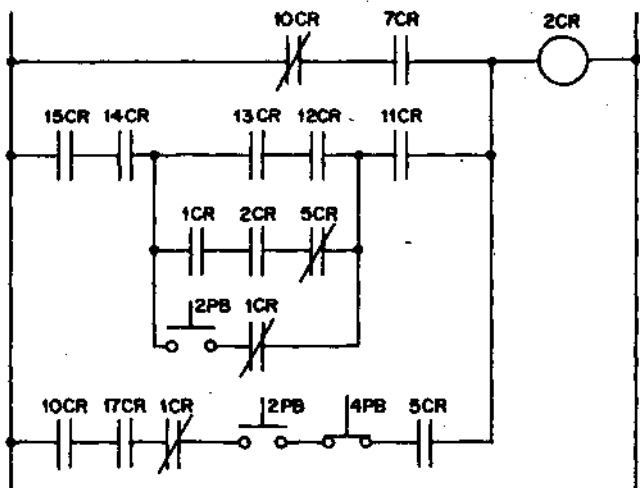
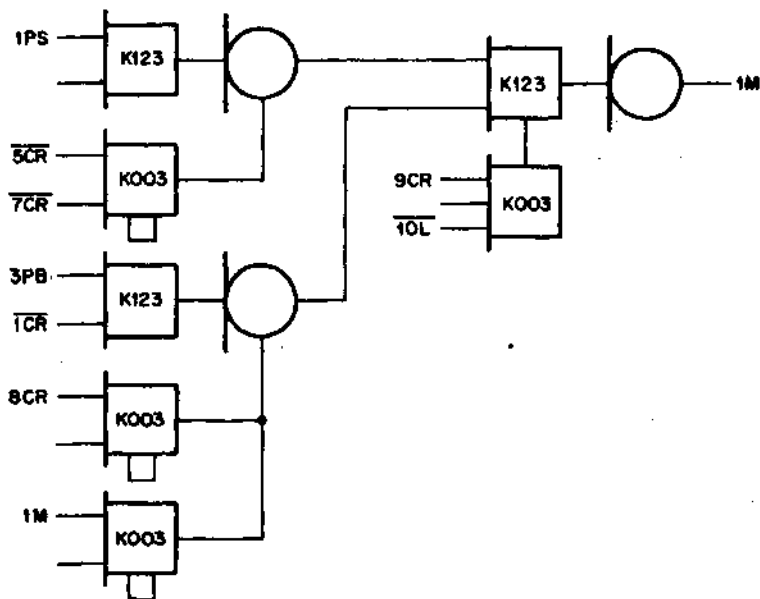

$$\begin{aligned}
 2CR &= (\overline{10CR} \cdot 7CR) + (15CR \cdot 14CR \cdot 11CR) \\
 &\quad [ (13CR \cdot 12CR) + (1CR \cdot 2CR \cdot 5CR) + (2PB \cdot 1CR) ] \\
 &\quad + (1CR \cdot 17CR \cdot 1CR \cdot 2PB \cdot 4PB \cdot 5CR)
 \end{aligned}$$

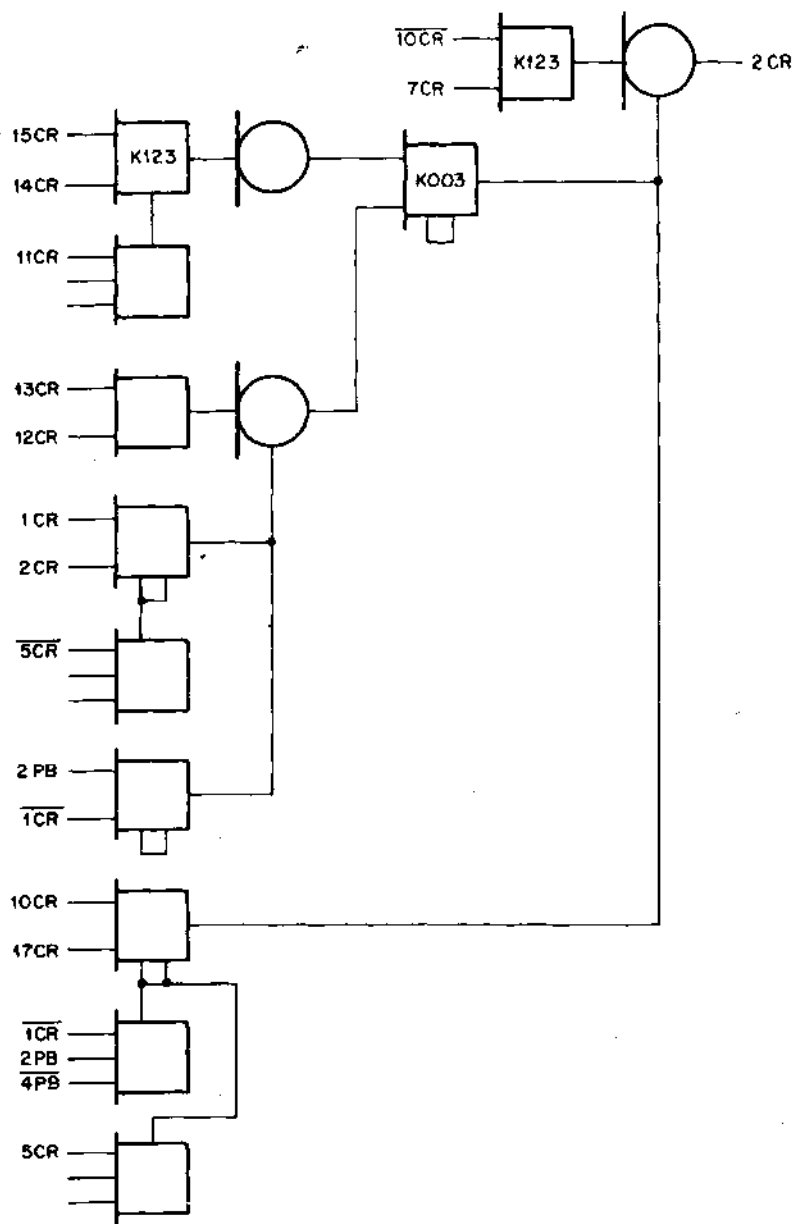

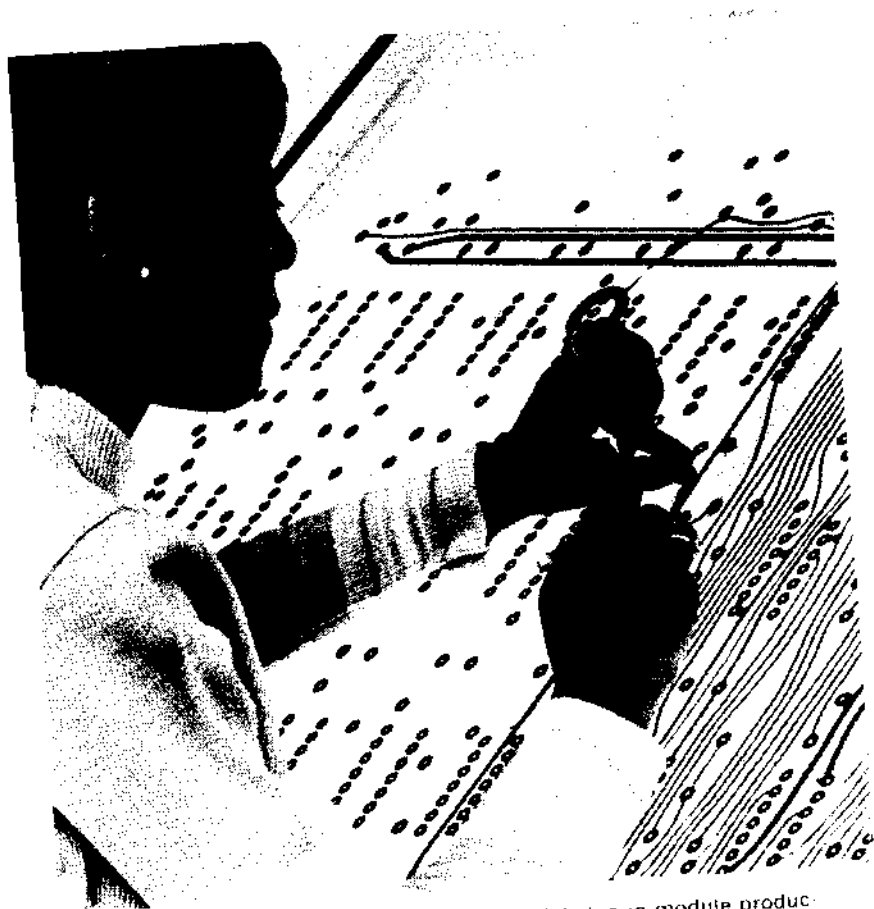

The printed circuit board layout is a crucial step in module production. Tolerances are checked to within  $1/5000$  of an inch.

ELECTRO-MECHANICAL		K SERIES	
J.I.C.	GENERAL	N.E.M.A.	MIL.
<p>2-INPUT AND</p> <p>(FORM A) (NO)</p>	<p>(FORM A) (NO)</p>	<p>F (M,T) H (N,U) D (K,R) AND A</p>	<p>F (M,T) H (N,U) D (K,R) AND A</p>
<p>EXPANSION TO 5-INPUT AND</p> <p>(FORM A) (NO)</p>	<p>(FORM A) (NO)</p>	<p>F (M,T) H (N,U) E (L,S) D (K,R) AND A AND B AND C AND D AND E</p>	<p>F (M,T) H (N,U) E (L,S) D (K,R) AND A AND B AND C AND D AND E</p>

APPLICATION



**ELECTRO-MECHANICAL**

**K SERIES**

**J.I.C.**

**GENERAL**

**N.E.M.A.**

**MIL.**

**2-INPUT  
INCLUSIVE  
OR**

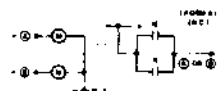

(FORM A)  
(NO)

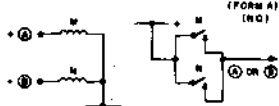

(FORM A)  
(NO)

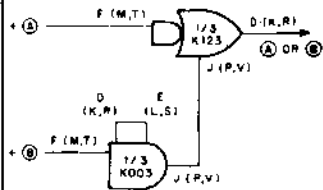
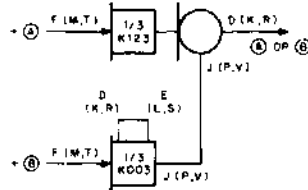

**5-INPUT  
INCLUSIVE  
OR**

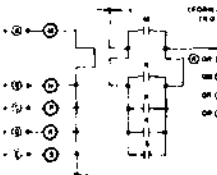

(FORM A)  
(NO)

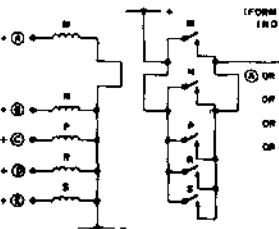

(FORM A)  
(NO)

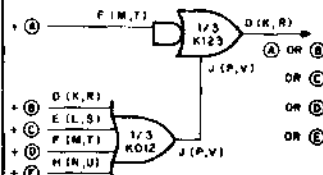
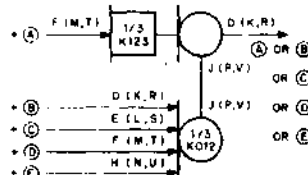

ELECTRO-MECHANICAL		K SERIES	
J.I.C.	GENERAL	N.E.M.A.	MIL.
<p><b>INVERTING FUNCTION</b></p> <p>(FORM B) (INC)</p> <p>INVERTED</p>	<p>(FORM B) (INC)</p> <p>INVERTED</p>	<p>(FORM B) (INC)</p> <p>INVERTED</p>	<p>(FORM B) (INC)</p> <p>INVERTED</p>
<p><b>2-INPUT NOR</b></p> <p>(FORM B) (INC)</p> <p>NOT (A) OR (B)</p>	<p>(FORM A) (INC)</p> <p>NOT (A) OR (B)</p>	<p>(FORM A) (INC)</p> <p>NOT (A) OR (B)</p>	<p>(FORM A) (INC)</p> <p>NOT (A) OR (B)</p>
<p><b>2-INPUT NAND</b></p> <p>(FORM B) (INC)</p> <p>NOT (A) AND (B)</p>	<p>(FORM B) (INC)</p> <p>NOT (A) AND (B)</p>	<p>(FORM B) (INC)</p> <p>NOT (A) AND (B)</p>	<p>(FORM B) (INC)</p> <p>NOT (A) AND (B)</p>

ELECTRO-MECHANICAL		K SERIES	
J.I.C.	GENERAL	N.E.M.A.	MIL.
<p><b>2-INPUT EXCLUSIVE OR</b></p> <p>OR</p> <p>(FORM C)</p>	<p>(FORM C)</p>	<p> <math>\bar{A}</math> F (M,T) 1/3 K123          NOT + <math>\bar{B}</math> H (N,U)          D (K,R) J1P,V1          E (L,S)  <math>\bar{B}</math> F (M,T) 1/3 K003          NOT + <math>\bar{A}</math> H (N,U) 1P,V1          D (K,R)          A OR B NOT BOTH       </p>	<p> <math>\bar{A}</math> F (M,T) 1/3 K123          NOT + <math>\bar{B}</math> H (N,U) J1P,V1          D (K,R)          A OR B NOT BOTH          D (K,R) E (L,S)  <math>\bar{B}</math> F (M,T) 1/3 K003          NOT + <math>\bar{A}</math> H (N,U) J1P,V1       </p>
<p><b>BISTABLE (FLIP-FLOP)</b></p> <p>LATCHING RELAY</p>	<p>LATCHING RELAY</p>	<p>         SET F 1/3 K113          RESET H 1/3 K113          INPUT SPLIT LUG 3, 4, 6, 7, 8, 9          OUTPUT 1, 2, 4, 6, 7, 9          A (K,R) NOT A       </p>	<p>         SET F 1/3 K113          RESET H 1/3 K113          INPUT SPLIT LUG 3, 4, 6, 7, 8, 9          OUTPUT 1, 2, 4, 6, 7, 9          A (K,R) NOT A       </p>
<p><b>OFF-DELAY</b></p> <p>1 SECS. DELAY</p> <p>CONTACTS SWITCH T SECS. AFTER START SYNCHRONOUS MOTOR OR PNEUMATIC TIMER</p>	<p>T SECS. DELAY</p> <p>CONTACTS SWITCH T SECS. AFTER START SYNCHRONOUS MOTOR OR PNEUMATIC TIMER</p>	<p>         OFF DELAY START K580          F (M,T) 1/3 K903          1/3 K113          INPUT SPLIT LUG 3, 4, 6, 7, 8, 9          QUENCH 1, 2, 4, 6, 7, 9          SET 1, 0.01 TO 30 SECS          OUTPUT LEVELS CHANGE 1 SECS AFTER START          D (K,R) NOT A          E (L,S) A       </p>	<p>         OFF DELAY START K580          F (M,T) 1/3 K903          1/3 K113          INPUT SPLIT LUG 3, 4, 6, 7, 8, 9          QUENCH 1, 2, 4, 6, 7, 9          SET 1, 0.01 TO 30 SECS          OUTPUT LEVELS CHANGE 1 SECS AFTER START          D (K,R) NOT A          E (L,S) A       </p>

# ELECTRO-MECHANICAL

J.I.C.

GENERAL

DECODER:  
BCD TO  
10 LINE

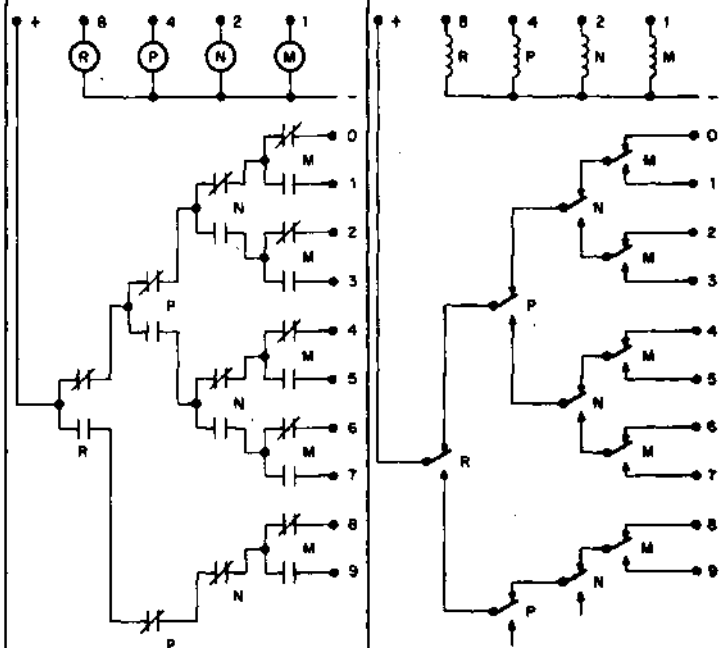

## K SERIES

N.E.M.A.

FROM K210 COUNTER

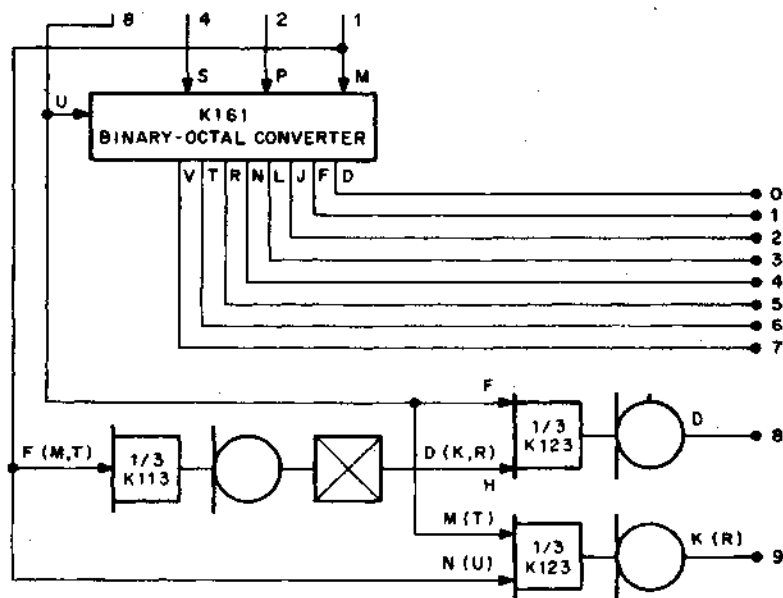

## MIL.

FROM K210 COUNTER

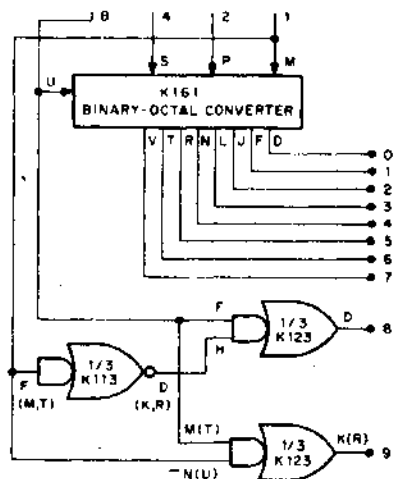

# ELECTRO-MECHANICAL

J.I.C.

GENERAL

CROSSBAR  
SELECTOR

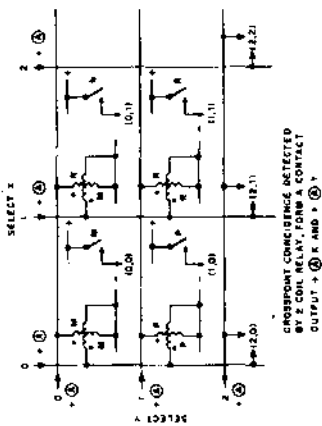
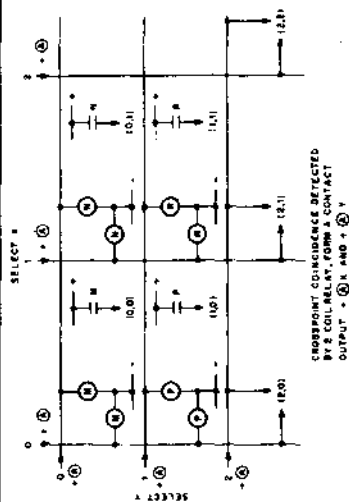

HOME-TO-

5

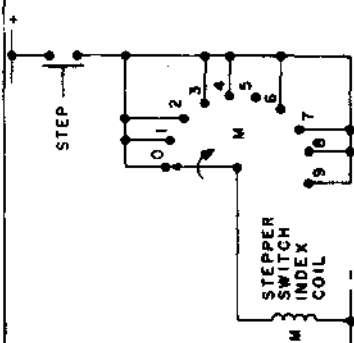
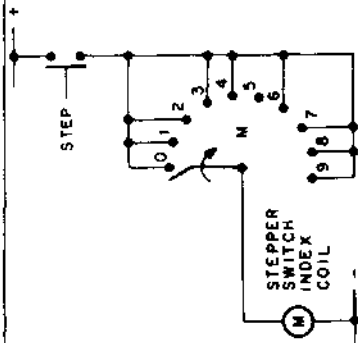

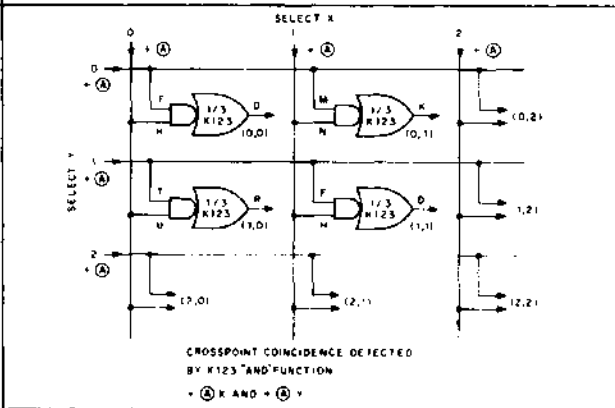
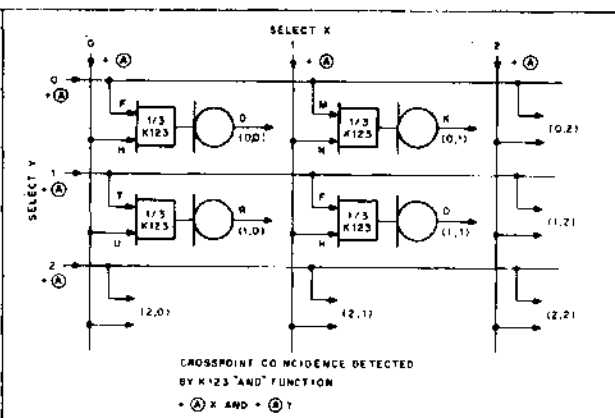
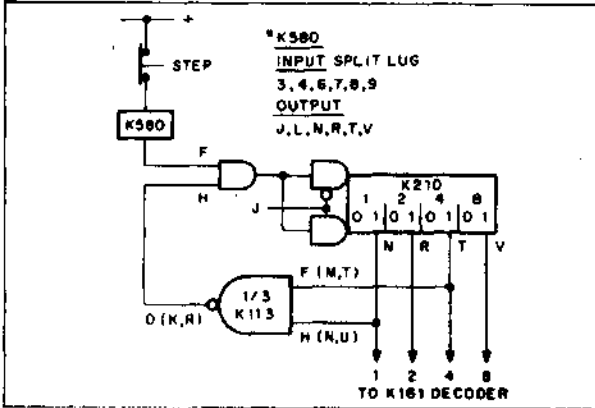
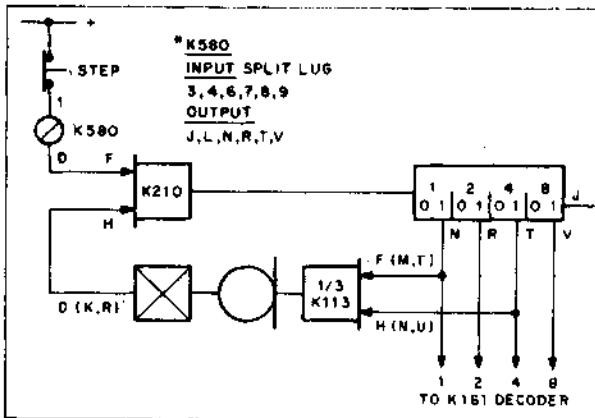

N.E.M.A.

K SERIES

MIL.

## K SERIES SEQUENCERS — GENERAL

A fundamental part of many K Series systems is a sequencer that controls the progression from one state or operation to the next state or operation. Four logic elements are available to define the state or operation currently in effect, and there are also several choices of method for moving from each state to the next, and for deriving output signals that include any arbitrary set of states. This note considers each sequencer in a general way, so that their overall merits can be compared before starting detailed design with the 1 or 2 most appropriate. The simplest sequencer of all, consisting of logic gates alone, is not mentioned here; but of course if AND and OR functions by themselves can do the job, splendid.

### 1. TIMER SEQUENCER

Several independent K303 timers connected in cascade form a very flexible, completely adaptable sequencer. If each timer input is driven by the direct (non-inverted) output of the previous timer, removing logic "1" from the first will cause all the outputs to fall like hesitant dominoes. A pushbutton, limit switch, etc. can then reset all timers by restoring "1" at the first until the next cycle is wanted. Or by connecting the timers in a loop with an odd number of inversions a self-recycling sequencer can be obtained. The clock circuits shown on pages 93-94 of the Industrial Handbook are special cases of this latter technique.

The complete adjustability of timer sequencers can be a disadvantage in some applications. When more than 3 or 4 steps are needed, the sheer number of knobs to twiddle begins to lead toward possible confusion and perhaps "provocative maintenance."

### 2. COUNTER SEQUENCER

One K210 counter provides up to 16 sequence states, and many more are obtainable by cascading. The counter may be stepped along by a fixed-frequency source such as the line frequency, or by a K303 clock. It is also possible to generate stepping pulses by completion signals from the processes being sequenced. K184 rate multipliers can be conveniently used to produce such pulses. Counter sequencers recycle without external aids at 9 or 15 (BCD or binary connections) and may be set to recycle at other steps as shown in K210 specifications.

Counter sequencers offer the most discrete states for the money, and the entire sequence can be scaled up or down in time simply by adjusting the input stepping rate. However, if many different output signals are to be derived from a counter sequencer, the gating can become complex unless the signals required happen to fit those available from K161 octal decoders or from the counter directly.

### 3. SHIFT SEQUENCERS

K230 shift registers can be connected as ordinary ring counters or as switch-tail ring counters. Specialized shift sequencers such as Barker



code (pseudo-random) sequencers are also possible. The most generally useful type is the switch-tail (Johnson code) ring counter, in which the last stage is fed back inverted into the first. This provides two states for every flip-flop, or 8 states if all four flip-flops in a K230 are utilized. The pattern achieved is the same falling-domino behavior obtained with the non-recirculating timer sequencer, except that the "dominoes" fall up one-by-one after they have finished falling down. Either fixed frequency or event-completion signals can be used to step a shift sequencer, just as for counter sequencers.

Shift sequencers cost more per state than counter sequencers. Their only advantage lies in the fact that any state or any collection of contiguous states can be detected by a simple 2-input gate. Not only does this feature simplify the derivation of many overlapping output signals, but it also offers excellent flexibility for modifications after construction. The need for only two connections to generate any once-per-sequence signal to start and end at any arbitrary state even permits practical patch-panel programming of output signals.

#### 4. POLYFLOP SEQUENCERS

If the state or operation in progress is to be determined in many cases by a combination of external factors, instead of primarily by the sequencer itself, a polyflop may be the best solution. A polyflop is simply a multi-state circuit which will remember the last state into which it was forced until the next input comes along. Polyflops can have any number of states, though the practical limit is probably 8 or fewer. Set-reset flip-flops are a very common special case of the polyflop, having 2 states. If you want a name for the next six types you could call them tripflop, quadraflop, pentaflop, hexaflop, septaflop, and octaflop.

The general polyflop is built from as many K113 inverting gates as there are states required, each with input AND expansion sufficient to gate together all outputs by the one that gate controls. Thus any one low output will force all other outputs high. Polyflops do not establish any fixed order through the possible steps as the other three sequencers do, and so perhaps should be called state memories rather than state sequencers. However, there are some situations in which a polyflop is found to be a superior replacement for one of the ordered sequencers, such as where several different outside signals must be able to force the control into corresponding specific states immediately without passing through the normal sequence.

#### SUMMARY

Sequencer Type	Relative Cost per State	Modification Flexibility	Other Features
Timer	highest	easiest	Can be self-stepping
Counter	low-med	fair	Best for many states, few outputs
Shifter	medium	good	Suitable for patch panel setup
Polyflop	medium	fair	States may be forced in any order

## TIMER SEQUENCERS

The simplest and most obvious way to sequence operations or states on a machine or in a control system is to use several timers in cascade. Below is shown a simple three-state timers sequencer.

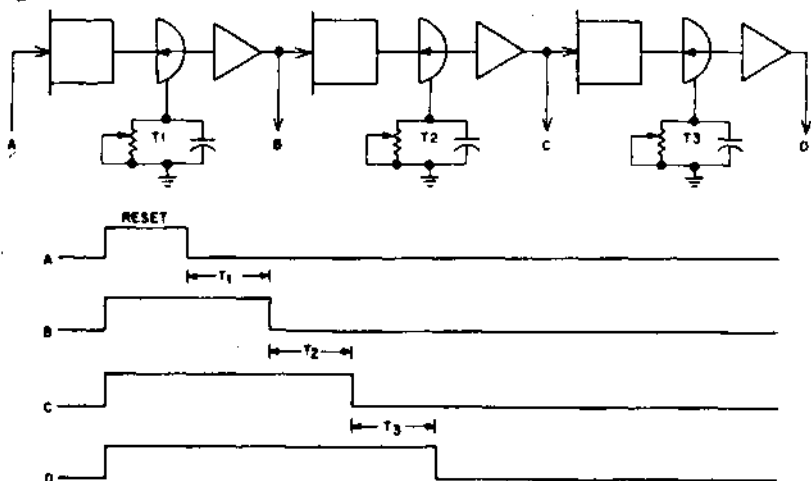

A pushbutton, clock, or another sequencer can provide signal A that resets all timers and begins the sequence. Any number of timers may be cascaded, but if many steps are needed one of the less flexible sequencers should be considered as a means of reducing the number of adjustments and the cost.

Outputs other than those available directly from the timers can be obtained by a two-input gate connected to appropriate direct or inverter timer outputs. For example, a signal true during both  $T_2$  and  $T_3$  can be obtained by ANDing output D with the inversion of output B. The possibility of deriving any once-per-cycle output from this type of sequencer with two-input gates only is a virtue shared with switch-tail shifting sequencers.

The inverted output from the last timer in the chain may be used to provide the initiate signal resulting in self-recycling. However, sufficiently large timing capacitors must be in use to allow the initiate signal to rise all the way to +5 V if normal relations between timing RC and time delays are to be maintained. The Timer Control section of this Handbook shows short self-recycling timer chains usable at high recycle rates. Three inversions, or any odd number of inversions must be contained within a self-recycling loop.

Many variations are possible by combining timer sequencers with other types of sequencers, branching to auxiliary sequencer chains, gating timer inputs from external devices, etc.

## COUNTER SEQUENCERS

Counter sequencers offer the largest number of discrete steps for the money, since for  $N$  flip-flops up to  $2^N$  states are obtainable. A single K210 counter, for example, offers up to 16 states for \$27.

A source of timing signals, such as the "line sync" output from the K730, K731, or a K303 clock may be used to advance a counter sequencer at uniform increments of time. In addition, event completion signals may be used to gate, augment, or substitute for the uniform time signal. One way to sub-

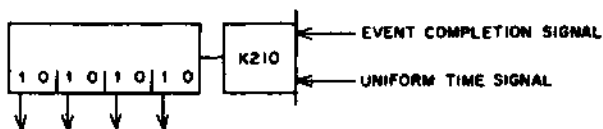

Event completion signal gates the time signal if the latter is a normally low, relatively higher frequency signal. Event completion signal augments the time signal if the latter is a normally high, relatively lower frequency signal.

stitute for time signals is to use a K184 Rate Multiplier as if it were four separate differentiating pulse generators with ORed outputs.

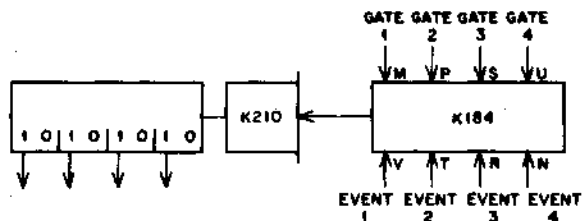

## USING K184 TO GENERATE EVENT COMPLETION PULSES

The principal disadvantage of counter sequencers is gating complexity, if many outputs must be derived which are not simply the flip-flop outputs themselves. Counter sequencers are most suitable for high-resolution sequencing of relatively few outputs whose relationship to sequencer states is unlikely to be modified after construction.

A crosspoint matrix offers reasonably low cost and good flexibility for developing counter sequencers with large numbers of states. For example, the 64 state sequencer shown here costs about \$100 before any 2-input state detectors are added.

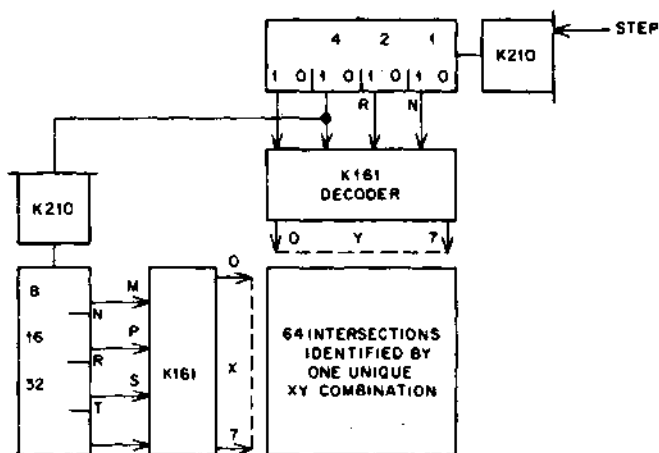

64 STATE CROSSPOINT SEQUENCER

The desired states may be detected one-by-one using any two-input AND gate such as those of gates K113, K123, or K134, or two-input gates on other modules like K210 counters, K230 shift registers, K303 timers, K604 or K614 AC switches, K644 or K656 DC drivers, etc. Or several states may be combined by ORing the outputs of several two-input AND gates as shown below.

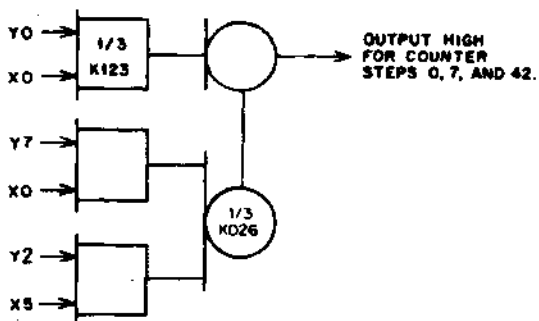

## SHIFTER SEQUENCERS

An alternate to the Counter Sequencer for generating many outputs, especially where some of the output sequences may be revised after construction, is the switch-tail shift ring.

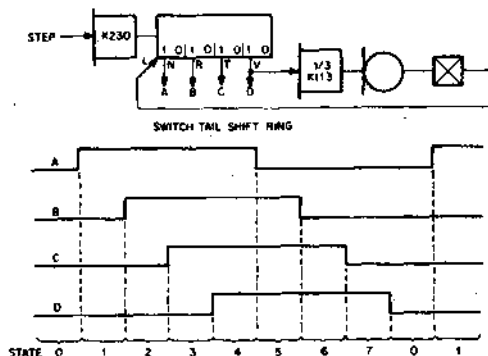

Any one state can be detected by a single 2 input gate. For example, state 2 is true if B is high and C is low; state 4 is true if A and D are both high, etc. Moreover, any contiguous array of states may be detected by a gate of only two inputs. For example, state 2, 3, and 4 can be combined by a two-input gate that looks for A and B both high. This convenient characteristic not only reduces the cost and complexity of output gating, but also makes last minute changes easy since no new gates have to be added to modify the steps to which a given output gate responds, so long as they are contiguous. Also, notice that state 0 is on an equal footing with the others so that "contiguous" states may include or span the zero or home state.

The two input gating rule could be exploited to permit patch-panel coding of a general-purpose sequencer. One possible arrangement for such a panel is shown here, for a four flip-flop sequencer. In use, one would simply AND start and finish signals that span the desired state or states.

## PATCH PANEL

START	A	B	C	D	$\bar{A}$	$\bar{B}$	$\bar{C}$	$\bar{D}$
FINISH	$\bar{A}$	$\bar{B}$	$\bar{C}$	$\bar{D}$	A	B	C	D
STATE	1	2	3	4	5	6	7	0

For the special case of four states to be spanned, only one connection is required. Observe that to span more than half the available states, it is necessary to detect their complement and invert.

Switch-tail shift rings can be driven from all of the same sources as counter sequencers, and may be extended to as many states as desired. If N is the number of shift register flip-flops,  $2^N$  states will be obtained in the sequencer.

## POLYFLOP SEQUENCERS

Just as a flip-flop can be set to one of two states and remember it, a logic circuit that has three, four, or more states will remember the last of its several states to which it has been set.

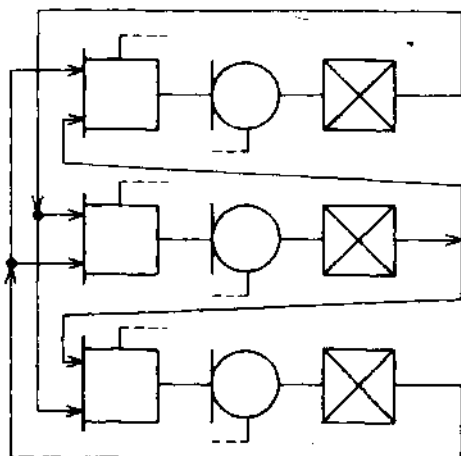

TRIFLOP

The fundamental principle of the polyflop is that each inverting AND gate must have an input from all other outputs but its own.

POLYFLOP	K113	K003	MODULE COST
TRIFLOP	1	0	\$11.00
QUADRAFLOP	1-1/3	1-1/3	\$21.00
PENTAFLOP	1-2/3	1-2/3	\$27.00
HEXAFLOP	2	2	\$32.00
SEPTAFLOP	2-1/3	4-2/3	\$50.00
OCTAFLOP	2-2/3	5-1/3	\$57.00
NONAFLOP	3	6	\$63.00

The table above shows the components needed to build polyflops in the practical range of sizes. Module cost figures refer only to module sections actually used, and there is a significant amount of wiring required for the larger polyflops. Nevertheless, there will be circumstances in which a polyflop is more efficient than either a more conventional sequencer or a collection of ordinary set-reset flip-flops. Through the OR-expansion capability of K113 gates, external signals can be readily gated into a polyflop using low cost gate expanders. Selected output is low; all others high.

### USING K303 TIMERS FOR FREQUENCY SETPOINT

A K303 timer will reset to the start of its timing cycle when its inputs become high regardless of its previous state. This feature can be exploited to distinguish two pulse repetition rates, to detect a missing pulse in an otherwise continuous pulsetrain, or to close a frequency-regulating feedback loop. (Note: Where critical requirements are placed on K303 timing consistency in the millisecond range, consider the use of a low-ripple supply such as H710 to minimize modulation of the timing period at the ripple frequency.)

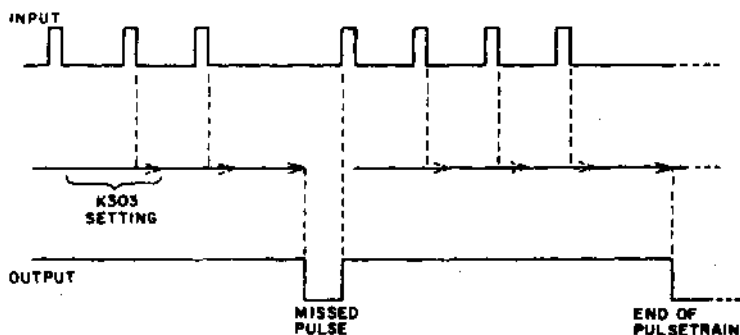

Input signal can be a square wave or pulses of any width down to 0.3% of the maximum delay available with the timing capacitor used. (Pulsewidths down to 0.1% or less may be used if timing consistency can be sacrificed). Timer delay would normally be set 30% to 50% longer than the nominal pulse repetition rate to detect missed pulses in a train, or at the geometric mean between two pulse periods which are to be distinguished.

By cascading timers, pulses as short as 300 nanoseconds may be stretched to any length needed. However, pulses less than several microseconds in length do not produce consistent or predictable time delays from the K303, and are only recommended for pulse-stretching (using built-in 0.002 mf timing capacitor).

## ESTIMATING K303 TIME JITTER

Repeat accuracy in the K303 can deviate as much as 8% of base time or frequency or even more if sufficient ripple is present on the voltage supply line. Jitter is related to frequency or time setting and may be estimated by the graph showing maximum jitter from a K731 power supply at 75% of its maximum output. (i.e. 1 ms. period @ 500 mv. supply ripple yields 8% jitter.) Jitter at a given frequency is also proportional to supply ripple.

Reduction of ripple in applications requiring high accuracy may be accomplished by using a separate, lightly loaded K731 or by using the H716 or H710 Power Supply. Recovery times less than 300C will be additive to supply jitter. When used as a clock the timer controls K371, K373, or K375 will provide the proper recovery times.

If peak-to-peak ripple is held to 100 mv, 95% repeat accuracy may be expected from the K303 at all the settings.

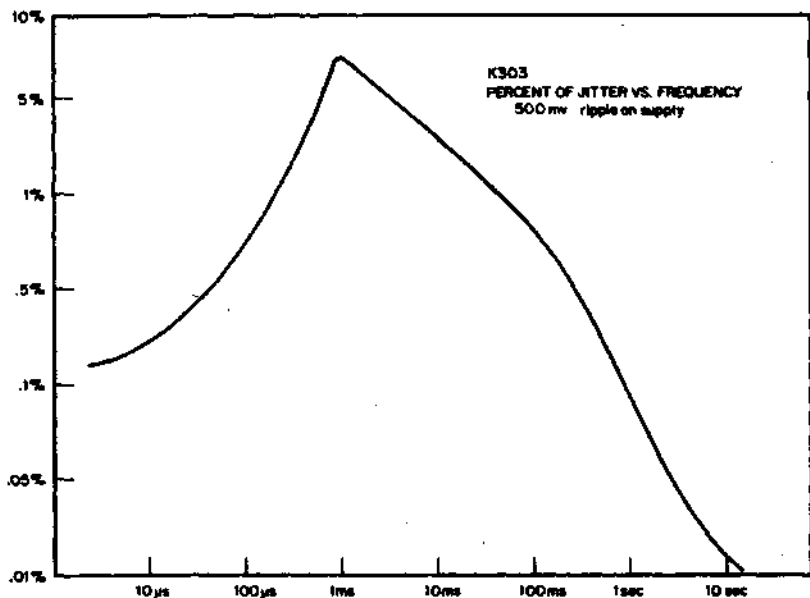



**COMBINING K WITH M-SERIES MODULES**

There are several types of applications in which a combination of M and K Series modules is better than either one alone, such as interfacing a K Series system to a computer or interfacing an M Series system to electro-mechanical devices. Here are the things to consider and recommended designs for both pulses and levels in each direction.

**TIMING**

Timing considerations are important, but unfortunately are not reducible to simple rules: as in any other logic design task, interfacing K with M Series modules requires adherence to all timing constraints of the output device, the input device, and the logic loops (if any) as a whole. As a minimum, M Series signal driving K Series circuits must last long enough (at least 4 microseconds even if no propagation within the K Series is required) so that the K Series will not reject it as if it were noise; and as a minimum, K Series signals driving M Series circuits must be received by M Series inputs that will not be confused by ultra-slow risetimes.

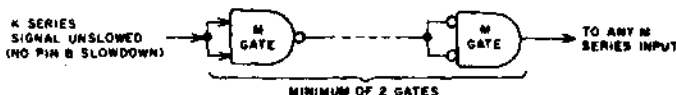
**K TO M SERIES LEVELS****K TO M-SERIES LEVEL CONVERTER**

Note: Total lead length connected to input of first M Series gate should be less than 6 inches, to minimize any tendency toward oscillation while active region is being traversed. Do not use slowed K Series levels. If noise still gets through, a .001 capacitor from M Series input pin to ground can be added.

**M TO K SERIES LEVELS**

1. Diode gate inputs (K113, K123, etc.) and drivers with flexprint cables (K604, K644, K671) may be paralleled freely with M Series inputs.
2. M Series outputs should not be paralleled (wired AND) with K Series outputs.
3. K303 inputs, K220, K230 readin gate inputs, and K135 and K161 inhibit inputs require the full 5 volt K Series swing, and normally should not be paralleled with M Series inputs. Also in this category are clear inputs to K202, K210, K220, and K230. M Series gate outputs will rise all the way to +5V if no M Series inputs are paralleled with these points, except the K161 Inhibit input.
4. Other K Series inputs generally may be driven directly, but in some cases heavy capacitive loading will slow the transitions.

## K TO M SERIES PULSES

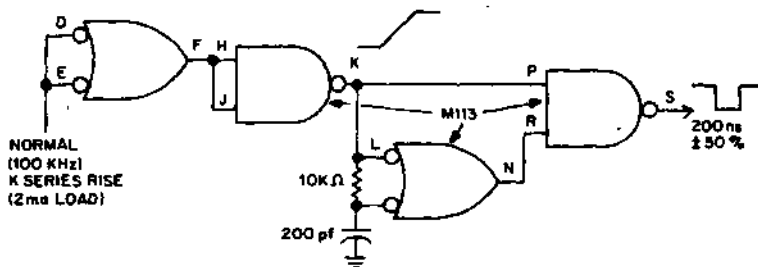

Note: Same input restrictions as K to M Series level converter. M113 may be replaced by M602 circuit if desired.

## M TO K SERIES PULSES

Use a type M302 delay multivibrator set for at least 5  $\mu$ sec (capacitor pins H1-L2 or S1-S2). Observe same restrictions on K Series inputs to be driven as listed above under "M to K Series levels."

### Loading

Driving M from K Series modules, each risetime-insensitive input should be regarded as a 2ma K Series load, and K Series inputs may be freely mixed with M Series inputs up to the total K Series fanout of 15 milliamperes. M Series inputs could be regarded as 1.6ma each if more complicated rules and qualifications concerning use with K303 timers and reduction in low-output noise rejection were established, but the 2 ma equivalence is simpler and safer.

Driving K from M Series, each milliampere of K Series load should be regarded as one M Series unit load.

For computer interfacing and other M-Series applications where K Series is used as a buffer to keep noise in the external environment from reaching high-speed logic, beware of long wires between the M and K Series portions. For full noise protection, all signal leads penetrating the noisy environment normally must have K-series modules at both ends. EIA converters (K596, K696) or lamp drivers may offer a helpful increase in signal amplitude or decrease in allowable line impedance for long data links. In any case, use all the slowdown connections or slant capacitors that the required data rates permit.

## COMBINING K WITH A SERIES MODULES

The voltage breakdown ratings of K series gate module inputs (K113, K123, K134) is high enough to withstand the  $\pm 10$  volt output swing of an amplifier such as A207, with correct gate output levels. This fact allows the A207 to be used not only as operational amplifier, but also as a comparator. A 12 bit slow speed analog-to-digital counter-type converter is made possible by using the A207 output directly as a logic signal.

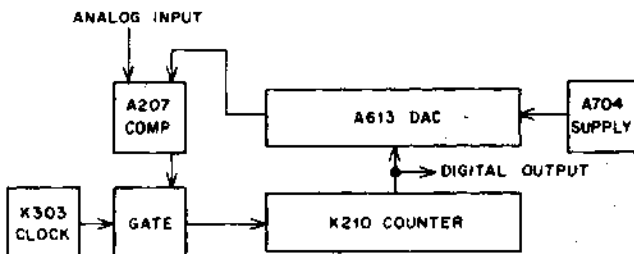

BASIC COUNTER CONVERTER FEEDBACK LOOP

In operation, the counter starts at zero and counts up until the D to A converter output just exceeds the analog input. As the comparator inputs reverse their polarity relationship, the comparator output switches and inhibits the clock. The counter is left holding a number representing the analog input voltage.

The 20 microsecond recovery time of the A207 used as a comparator restricts operation to below 50 KHz. In the system shown here, the comparator "done" signal forces the clock output to the high state. Operation is re-started by clearing the counter or by an increase in the analog voltage. If a control flip-flop were added between the comparator and the gate, action could be halted regardless of input voltage change until a new "start" signal. Maximum conversion time is 4095 times 30 microseconds, or about 120 milliseconds. (The extra 10 microseconds allows for counter carry propagation time and the time required for the A613 output to change one small step).

A faster converter may also be built using up/down counters or by building a successive-approximation type of converter.

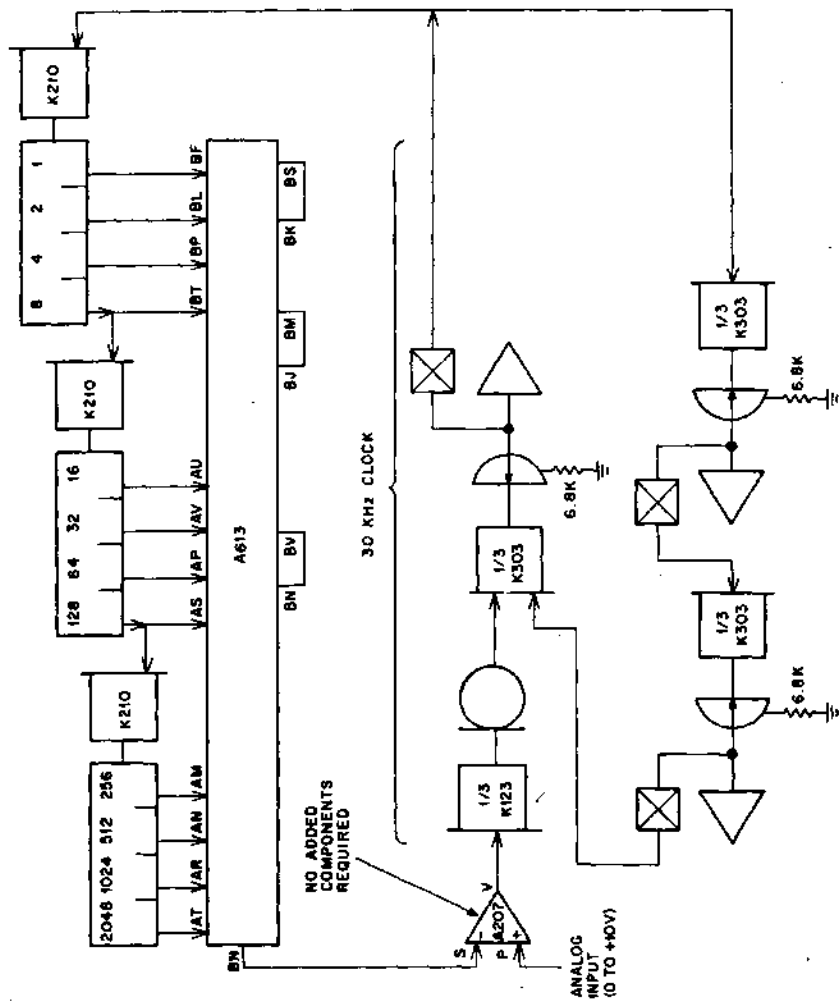

12 BIT ANALOG TO DIGITAL CONVERTER

## COMBINING K WITH R SERIES MODULES

For conversion from R series or other zero-and-minus levels to K series levels, the W603 (seven circuits, \$23) may be used. When driving gate module or timer inputs, and most other K series inputs as well, pins B and V may be left open if desired (no +10 V supply). For conversion from K series to R series levels, use W512 (seven circuits, \$25). For a more complete description of these FLIP CHIP modules, ask for the DIGITAL LOGIC HANDBOOK C-105.

There are two modules in the R series which can be used directly in the K series: The R001 and R002 gate expanders. The R001 is convenient for adding one extra input to a K-Series expandable AND gate, while the R002 can facilitate multiple inputs to several expandable AND gates from the same logic signal.

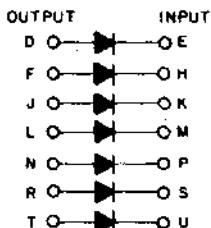

R001 DIODE NETWORK

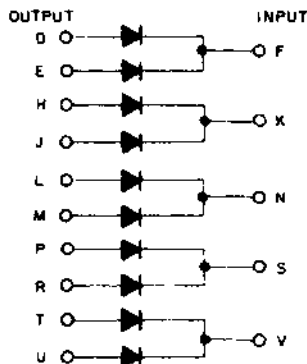

R002 DIODE NETWORK

R001 — \$4

R002 — \$5

### PULSE GENERATOR FROM NAND GATES

An effective pulse generator is formed by adding a capacitor to the OR node of a K113 inverting gate, as shown below. The circuit converts positive level transitions to pulses for clearing flip-flops, etc. Pulse width is slightly greater than  $1000 C$ : 1.0 microfarad produces 1.0 to 1.5 millisecond pulses, 0.01 microfarad produces 10 to 15 microsecond pulses. The input must remain low for several times the pulse width for reasonable pulse width consistency.

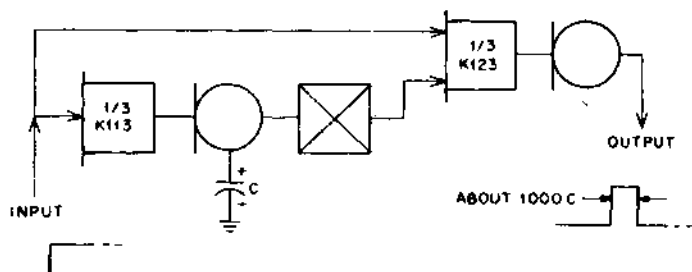

PULSE GENERATOR

Each K003 gate expander module includes a 0.01 mf capacitor from pin B to ground, suitable for use in this circuit to obtain pulses approximately ten microseconds wide. This is essentially the same scheme used to obtain one-shot behavior with K303 timers.

Inverted output pulses for clearing flip-flop registers, etc. may be obtained by substituting a K113 for the K123 gate shown.

The input low to high transition must be from an unslowed K Series output. If a slowed risetime is used, such as from a K580, K581, or K578, the output will remain low. Use a K501 Schmitt Trigger if the risetime needs to be speeded up.

## K531 QUADRATURE DECODER APPLICATIONS

The K531 can be used to provide all the necessary control signals to operate a K220 BCD up/down register for Nixie Displays or a K220 Binary up/down register for computer interfacing.

The same encoder can be used to operate two K531 modules so that a NIXIE display can be provided with the binary interface.

## FIVE DECADE POSITIONAL NIXIE TUBE READ OUT

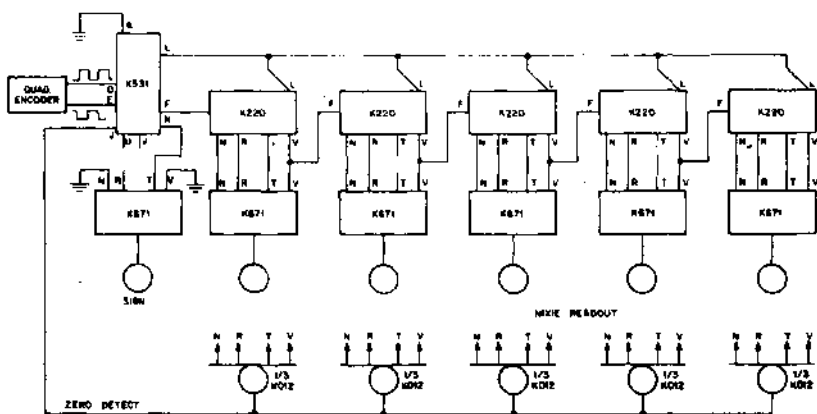

## Total System Consists Of:

5	K220	\$52.00	\$260.00
1	K531	\$70.00	\$ 70.00
2	K012	\$ 8.00	\$ 16.00
6	K671	\$55.00	\$330.00
1	K741	\$30.00	\$ 30.00
1	K731	\$30.00	\$ 30.00
			<u>\$736.00</u>

## 19 BITS PLUS THE SIGN BINARY INTERFACE

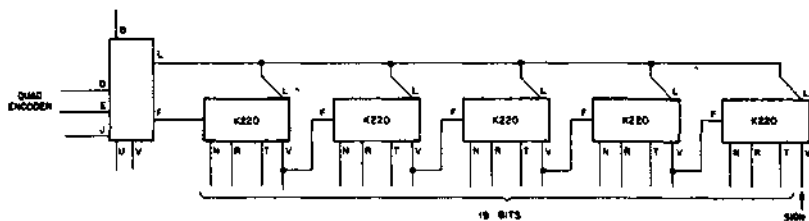

**Total System Consists Of:**

5	K220	\$52.00	\$260.00
1	K531	\$70.00	\$ 70.00
1	K741	\$30.00	\$ 30.00
1	K731	\$30.00	\$ 30.00
			\$390.00



## SENSOR CONVERTERS — OPERATION AND APPLICATIONS

Sensor Converters are basically voltage comparators that compare an unknown variable input voltage against a fixed known internal or external reference voltage called the threshold voltage. If the unknown voltage is higher than the reference voltage, the comparator output will be a logic 1, and if it is less, it will be a logic 0. K-Series has two different converter modules, the K522 with a built in +1.8 Volt reference and the K524 with a +2.5 V reference. In most applications the inexpensive K522 module can be used, except where high common mode noise rejection, sensitivity, or 120 VAC input protection are required or where DC levels or signals are to be compared. The following application examples cover the major uses of sensor converters.

### I. Signal comparison against the internal voltage reference

Use either the K522 or K524. Twisted pair wiring should always be used between the transducer and sensor converter.

### A. Variable Resistance Devices. (Add trimpots to K522 and K524 module in predrilled mounting holes.)

1. CdS photoconductive cell
2. Thermistor
3. Rheostat (Pressure Transmitter)
4. CdSe, Si, or Se photo cells

All variable resistance devices require the use of a bias supply and trimpot in order to generate a voltage that will vary each side of the fixed internal reference supply. Predrilled trimpot mounting holes are provided on each circuit on both the K522 and K524 for this purpose. The K522 +3.6V bias supply is automatically connected when the trimpot is mounted on the board. On the K524 an external +5V bias supply must be connected to pin B on the B connector. This +5 supply can be the logic supply, but it is recommended that a separate K731 supply be used to protect the logic system from accidental contact with 120 VAC. If the logic supply were used for bias, all modules in the system would be destroyed if an accidental short to 120 VAC did occur. Only when the resistance of the transducer is greater than the resistance of the trimpot will the sensor converter output be high. The transducer and trimpot should be picked in the following manner.

#### Transducer

The resistance of the transducer at the desired sensing point must be greater than 400 ohms and less than 20K for the K522 and less than 100K for the K524.

#### Trimpot

The resistance of the trimpot must be adjustable to equal the transducer resistance at the desired sensing point.

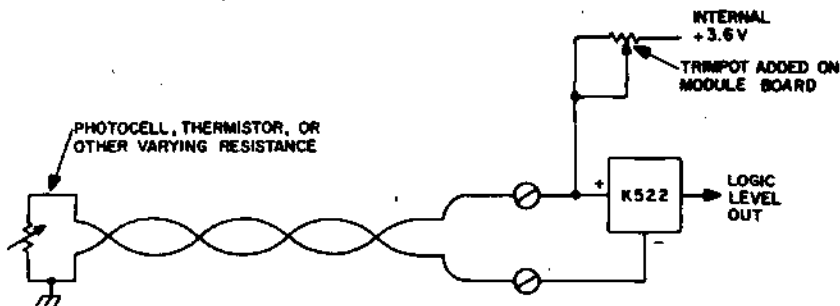

**K522 WITH NEARBY SENSOR**

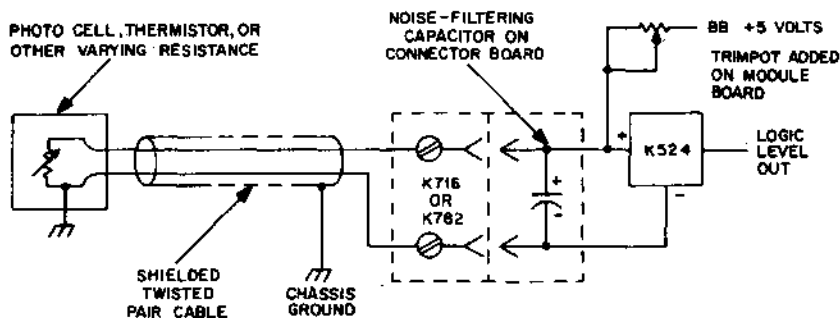

**K524 WITH DISTANT SENSOR**

**B. Voltage generating devices (Trimpots or bias are not required)**

1. Pulse tachometer
2. Potentiometer

Some types of voltage generating devices can be sensed directly by a K522 or K524 provided that the voltage will vary each side of the fixed internal reference voltage. If the voltage swing does not go above the internal reference supply voltage of either sensor module, the K524 will have to be used with an external reference supply. If it does not go below the internal reference supply voltage, voltage or current level sensing will have to be used.

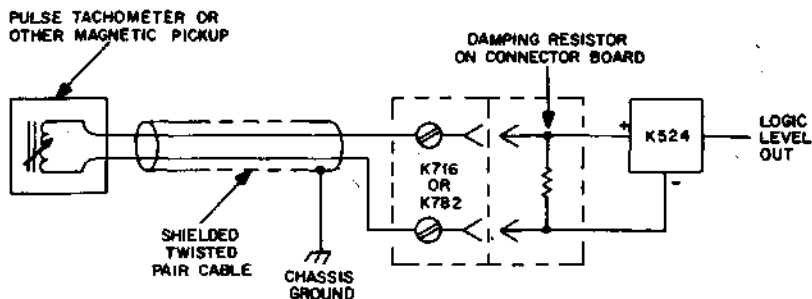

### C. Voltage or current level sensing.

(If the voltage swing at the sensor converter + input will ever go negative, use the K524.)

#### 1. Voltage level sensing

To sense a voltage level greater than the internal reference supply voltage, a resistor divider should be used to attenuate the signal as follows:

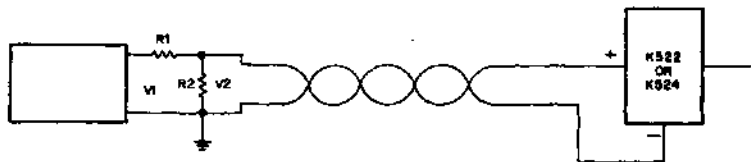

$R_2$  must be between 0 ohms and 20K for the K522, 0 and 100K for K524.  $R_1$  and  $R_2$  should be chosen so that  $\frac{V_1 \text{ (max)}}{R_1 + R_2}$  equal the maximum output

current available or  $R_1 + R_2$  equal the minimum allowed load resistance and  $\frac{VR_2}{R_1 + R_2}$  equals the internal threshold voltage of the sensor converter. (V is

the voltage level to be sensed.)  
voltage level to be sensed.)

2. Current level sensing  $R_1$  and  $R_2$  should be chosen so that  $R_1$  equals zero ohms, and  $IR_2$  equals the internal threshold voltage of the sensor converter. (I is the current level to be sensed.)

#### II. Signal comparison against an external voltage reference. Use the K524 only.

##### A. DC threshold comparison

When the K524 control pins are connected for DC coupling the output will switch when the + input is within .3V of the voltage level of the minus input. Zero crossings at the + input signal can easily be detected by grounding the minus input. DC levels between  $\pm 7.5V$  can be sensed by connecting an external supply of the desired voltage level to the minus input. Since the minus input can only accept voltage level between  $\pm 7.5V$  while the plus input is good for  $\pm 30$  volts, CMR to noise spikes will be lost as the minus input voltage approaches + or - 7.5 volts. A better method to use in sampling large voltages is with a voltage divider. To sense a positive voltage, use the method described under *voltage level sensing*. To sample a negative voltage level, use the same technique, but connect the minus input to a negative voltage reference. The resistor divider calculations are the same as described for positive voltage levels, except the module threshold voltage will now be equal to the negative voltage reference on the minus input.

##### B. DC signal comparison

If the signals to be compared are between  $\pm 7.5$  volts the comparison can be made directly by connecting one signal to the + input and the other one to the - input.

If the signals are greater than  $\pm 7.5$  volts or maximum common mode noise rejection is desired, a resistor divider should be used across each signal output to reduce the voltage swing. The same resistor values should be used for both dividers.

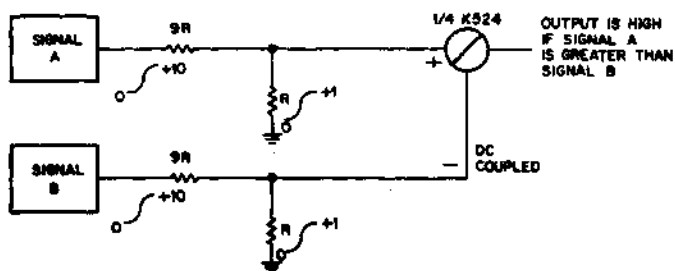

## DC DRIVERS

### CURRENT PATH CONTROL

All K-Series DC drivers sink current to ground and they all have a terminal, connector pin, or split lug that is specified as the load supply ground. To help segregate high D.C. currents from the logic system ground, these special ground connections must be wired directly to the minus side of the load supply. Where more than one load supply is being used, the minus sides should be bussed together. Ground the minus side of the supply to the chassis ground where they are mounted.

By providing this direct connection from the module to the load power supply, heavy currents are forced to flow through the ground return wire and not through the chassis ground.

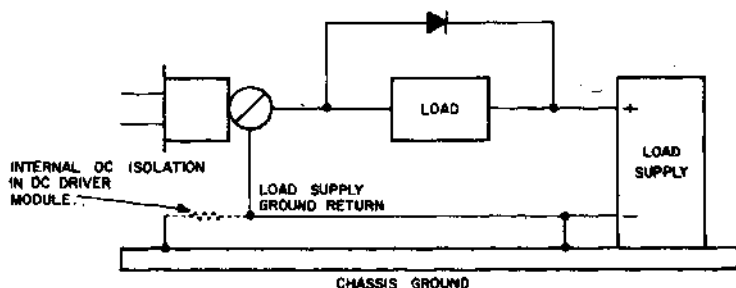

**NOTE:** If the ground return wire is not provided, current will have to flow through the chassis ground.

### CLAMP DIODES

All K-Series DC driver except the K681 and K683 have clamp diode protection available if the module is being used to control inductive loads. Protection can be obtained for the K681 and K683 if they are used with the K784 module. These clamp diodes provide protection for the output transistors from high voltages during turn off and must be connected to the positive side of the load power supply. If different load supply voltages are being used on a given module, connect the diodes to the positive side of the highest voltage supply. For resistive loads or lamps, the diodes are not required, but as a standard practice they should be connected as a safety precaution.

### DRIVER SELECTION

The individual data sheets state the maximum voltage or current capability of the modules. If, for example, the specification states a voltage of 125 volts at up to 4 amps, this means that any load supply voltage between 1 volt and 125 volts may be used and that the module will conduct current when it is turned on up to 4 amps maximum. If the load has a surge current rating of 3 amps and a holding current of 1 amp, the driver must have at least a 3 amp rating. For this application the K658 should be used.

In some applications it is desired to let the current fall rapidly in an inductive load. If the clamp diode is returned directly to the load supply, the current will fall slowly because it will circulate through the load until it is dissipated due to the resistance of the inductive load in the form of heat. The current decay rate can be increased by putting a resistor in series with the clamp diode return. The maximum resistor value allowed is given by the formula.

$$R = \frac{V_{\max} - V_p}{I_L}$$

$V_{\max}$  = maximum voltage rating for module

$V_p$  = load supply voltage

$I_L$  = maximum load current

The peak power dissipated in the resistor will be  $I_L^2 R$ . The actual watt rating of the resistor may be smaller than this if the inductance is small or the repetition rate is slow, but you will be safer if you use the maximum watt rating. As can be seen from the formula, the higher the voltage rating is for the module, the larger R can be, and the faster the current will decay. The K656 is useful for this application because of its 250 volt rating.

### DRIVERS IN PARALLEL

The DC drivers may be connected in parallel to obtain greater current driving ability, however, there are two important considerations.

1. Paralleled drivers must all be on the same module.
2. The current handling capability increases as the square root of the number of drivers that are connected.

Example:

1 driver = 1 amp

2 drivers = 1.4 amps

3 drivers = 1.7 amps

4 drivers = 2 amps

## USING K210s FOR LONG ODD-MODULUS COUNTERS

The pulse generator shown on the previous page can be incorporated with K210 counters to obtain counts at non-binary moduli above 16, the limit for a single K210. Below is shown a modulus 24 counter, as would be required for a digital clock.

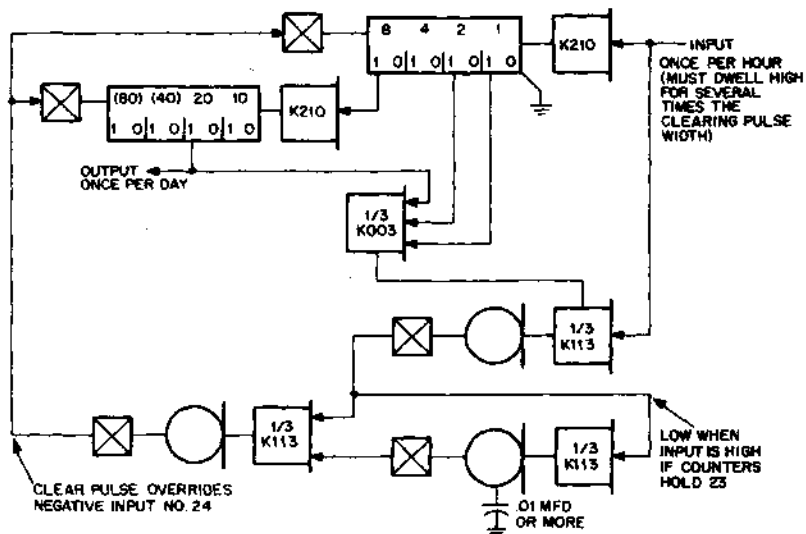

The basic principle involved is to detect the largest number to be permitted, and to generate a clear pulse when it disappears due to the reception of one more count. The same method may be extended to counters of any length, provided the clear pulsewidth is wide enough to override any possible carry propagation.

## PARALLEL COUNTERS

The counters shown elsewhere in this handbook are "serial" counters: that is, the input to a counter module of high significance is the simple output of the next less significant flip-flop, resulting in a time difference between groups of outputs (within any K210, K220, or K230 module all outputs switch essentially simultaneously).

If a long counter is driving a large decoder, or if flip-flop outputs from different parts of the counter are being gated together for any purpose, carry propagation time down a serial counter can give rise to false transients lasting several microseconds from the decoder or gating. In effect, the carry propagation time causes the counter to pass through one or more wrong counts on the way to the correct state.

The solution is to feed count pulses in parallel to all modules simultaneously, but gating the pulses to modules of high significance with the "1" outputs from all bits of lesser significance. The diagram below shows how this is done for an 8 bit (or two decade) K210 counter. Observe that modules of higher significance would need input gates expanded to 9, 13, or 17 inputs for 12, 16, and 20 flip-flop counters respectively.

Photoelectric shaft-angle transducers generate signals A and B in quadrature. Where maximum resolution and/or two-way counting is desired, the scheme below can be used to interface the amplified transducer outputs to the counter control shown on K220 data pages.

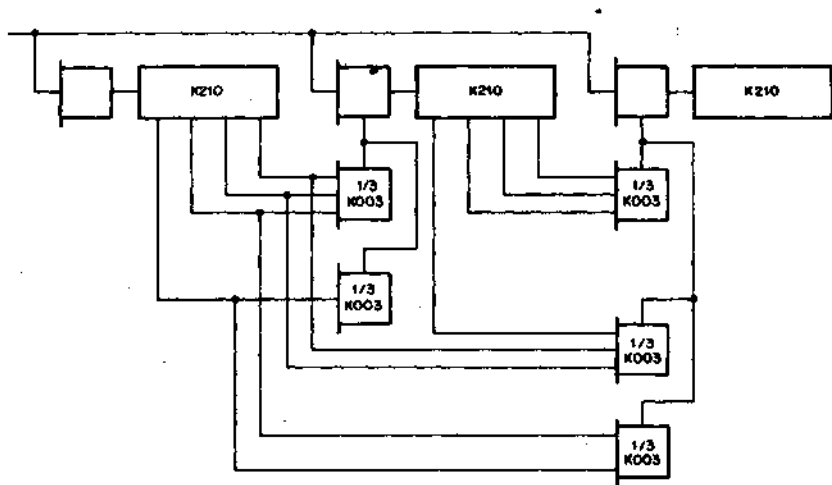

12 BIT PARALLEL BINARY COUNTER



## ANNUNCIATORS

In the simplest type of annunciator, a single alarm device is triggered by any abnormal occurrence, and a lamp is lighted by the occurrence to identify it. An inexpensive annunciator of this type can be built by taking advantage of the four Schmitt triggers and differentiators in the K184 module as indicated below. If silver contacts are to be sensed, auxiliary load and higher voltage must be used, preferably 120 VAC with K604-K716 or K614. Any number of inputs may be handled by ORing K184 outputs (wired OR if possible for up to 5 K184s). The normal 5  $\mu$ sec K184 pulsewidth should be stretched to 140  $\mu$ sec for use with a slowed-down alarm lamp flip-flop by putting a 0.1 mf capacitor from each K184 pin J to ground.

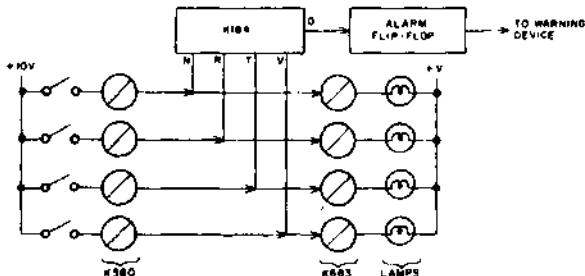

SIMPLE ANNUNCIATOR FOR FOUR DRY CONTACTS

In larger systems or where an abnormal occurrence may be too brief to be identified from a simple direct driven indicator, flip-flop memory must be added to each line to set up this sequence of operations:

ALARM STATUS	ANNUNCIATOR LAMP STATUS
1. No Alarm	Off
2. Alarm — Unacknowledged	Flashing (2Hz)
3. Alarm — Acknowledged	Steady
1. No Alarm — Memory Cancelled	Off

The Flash Supply is generated at a suitably low frequency by a K303 Clock with K375 Timer Control. This supply is available for distribution to other similar stages in a system.

The Alarm F.F. is set with an Alarm Input at Logic 1, the K580 controls the Alarm 0 to 1 response time. (See K580 data sheet) This allows the Lamp to flash. The Alarm F.F. is not cancelled, should the Alarm Input return to Logic 0. The initial Alarm must first be acknowledged manually before the Alarm F.F. is reset. Acknowledging the Alarm changes the Lamp from Flashing to Steady, and prepares the Alarm F.F. for Reset by the Alarm Input returning to Logic 0.

## K Series Modules per Annunciator

MODULE TYPE	NUMBER REQUIRED	NUMBERS OF CIRCUITS USED	COST PE LINE
K003	1 @ \$ 5.00	3 of 3	\$ 5.00
K113	1 @ \$11.00	1 of 3	\$ 3.60
K123	1 @ \$12.00	3 of 3	\$12.00
K134	1 @ \$13.00	1 of 4	\$ 4.33
K580	1 @ \$28.00	1 of 8	\$ 3.50
K681	1 @ \$15.00	1 of 8	\$ 1.80
<b>TOTAL</b>			<b>\$30.23</b>

The cost of common items, K303, K375, Power supplies etc., must be spread equally over the number of Annunciators in a system to get the true cost per stage.

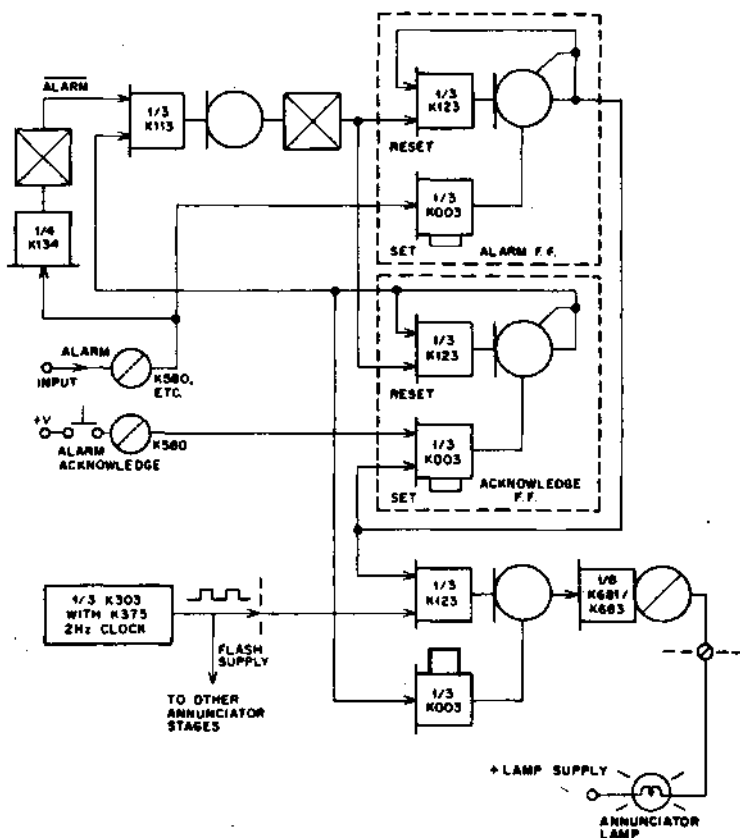

## THUMBWHEELS AND MULTIPLEXING THEM WITH K581

Binary-coded decimal thumbwheel switches of many sizes and types are available to provide convenient manual data entry into K220 and K230 reading gates via K580 switch filters. Below are listed some of the many types that can be used this way:

MANUFACTURER'S TYPE	PANEL CUTOUT HEIGHT	WIDTH PER DIGIT*
Digitran 315	1.380"	0.500"
Digitran 13015	2.000"	0.500"
Digitran 715	0.980"	0.500"
Digitran 8015	0.980"	0.500"
Digitran 9015	1.375"	0.600"
EECo 5305	0.960"	0.500"

\*Note: Additional "zero digits" width generally required in panel cutout.

The simplest hookup uses one K580 for every two decimal digits as shown here.

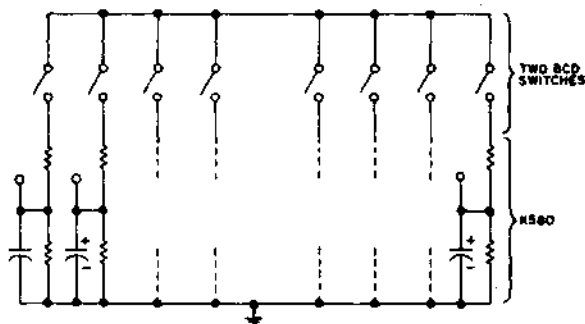

Power for the unmuxed system can be obtained from a 10 volt DC power supply or by using the circuit shown here with the auxiliary 12.6v winding on the K743 transformer.

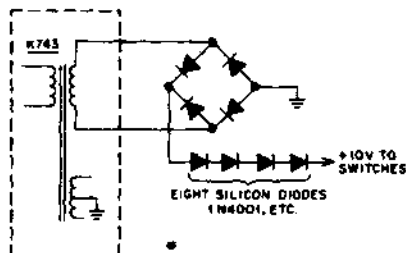

GETTING +10V FROM K743 USING A K730

Where more than one or two thumbwheel registers are needed it may be economic to multiplex several digits through the same K581 circuits as shown below. This scheme requires diodes to be mounted on the switches, as provided for by all of the types listed above. IN4001 diodes may be used.

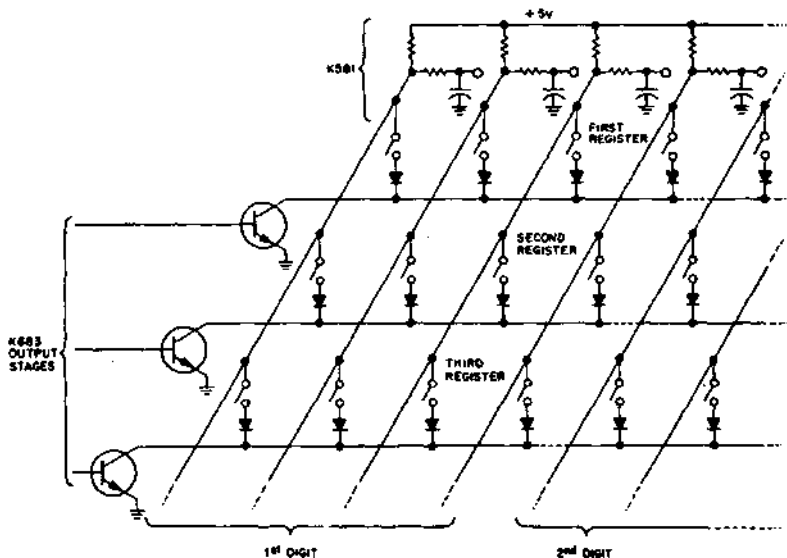

To sequence through the registers, it is necessary to turn on one K683 circuit at a time; this can be done by a K161 binary to octal decoder. Since no BCD decade can draw more than 60 milliamperes, as many as four decades can be handled on any one K683 switch. Circuits may be paralleled for larger registers.

Notice that K581 outputs will be one diode drop above ground in the "low" state: This restricts multiplexing to use with K220 or K230 readin gates, or to K113, K123, or K134 inputs at 1 milliamperes only. If the diode outputs (connector) on K683 are used, noise rejection will be reduced to levels that would normally be unacceptable. Direct (solder lug) connections are definitely recommended.

## FIXED MEMORY USING K281

Switch registers such as those shown on the preceding page may be considered as memory devices. Very often a system that needs thumbwheel memory (or flip-flop memory) can also benefit from memory that is not readily changed. By using a K281 board with diodes cut out where "zero" is to be recorded, many types of sequence or character (symbol) codes may be permanently stored in a digital system.

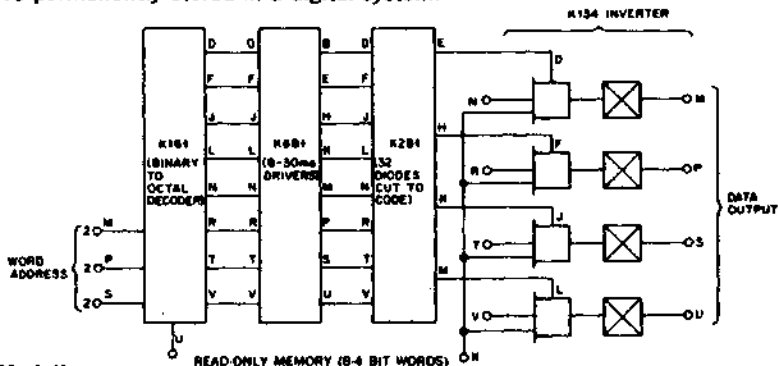

## Variations

## More 4-bit words:

- Use same K161 and K681
- Duplicate K281 and K134, tying K134 outputs together
- Use pin K inhibit on K134s to select 8 words
- Up to 40 4-bit words may be obtained (fanout down to 3)
- For more 4-bit words use longer words and gate outputs

## Longer Words:

- Use same K161 and K681
- Duplicate K281 and K134; two for 8 bits, three for 12 bits, etc
- Single K681 capable of word lengths to 28 bits
- Get more than 8 words as in getting more 4-bit words

## Serial Scanout:

- Connect word address lines to scanning counter
- Tie together K134 outputs
- Select word at K134 pins N, R, T, V.
- Second K161 can select word at K134 inputs
- Scanning and word-address K161s may be swapped
- This system is expandable in two dimensions also

Note: The K681 Lamp Driver lacks the noise immunity and output slowdown designed into all of the general-purpose K-Series logic modules. For this reason it is important to take advantage of congruent pin assignments by assigning adjacent module slots to K161, K681, K281, and K134 modules used in memory applications.

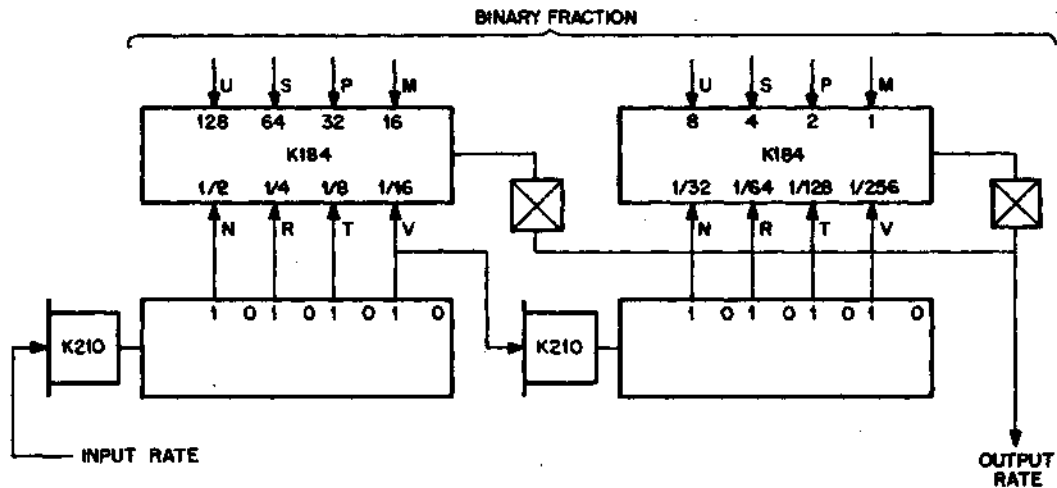

K184 RATE MULTIPLIER

APPLICATION

## RATE SQUARER

This circuit shows one of the many fascinating and useful tricks possible with rate multipliers. Here the output rate varies as the square of the input rate, so that, for example, a flywheel rotation rate could be read out in units of stored energy, etc.

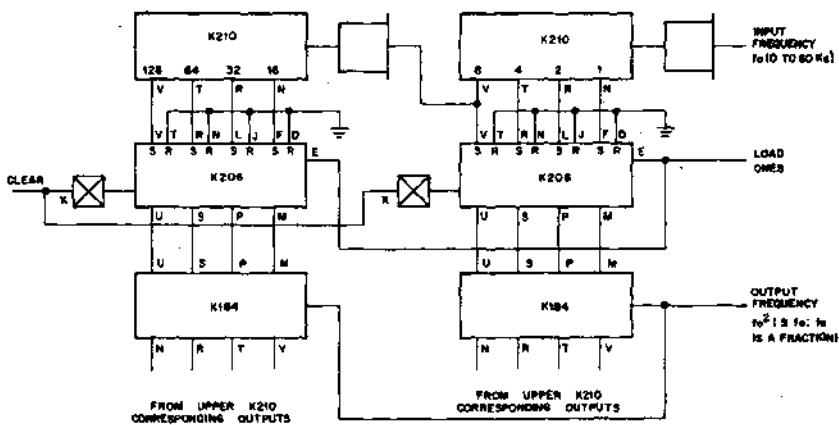

## SEQUENCE OF OPERATION

0. K230 holds previous rate number; K210s cleared
1. Gate  $f_0$  to K210 counter for fixed period
2. Stop counter at end of interval; clear K206s and read in
3. Clear K210 and return to step 1.

MODULE COST	
2 K210 @ \$27.	\$ 54.00
2 K206 @ 20.	\$ 40.00
2 K184 @ 25.	\$ 50.00
TOTAL excluding control	\$144.00

NOTE:  $f_0$  is regarded as a fraction, where 1.0 is that frequency which just fills the counter during the count interval. Average output rate is the product of current count rate times the average rate in the previous interval. The sampling period must be short relative to the variations in input counting rate.

## K184 AS A DIGITAL INTEGRATOR

If the fraction  $F$ , to a K184 is derived from a Counter also incremented by the input frequency  $f_i$ ,  $f_o$  increases, on average, in a linear fashion.

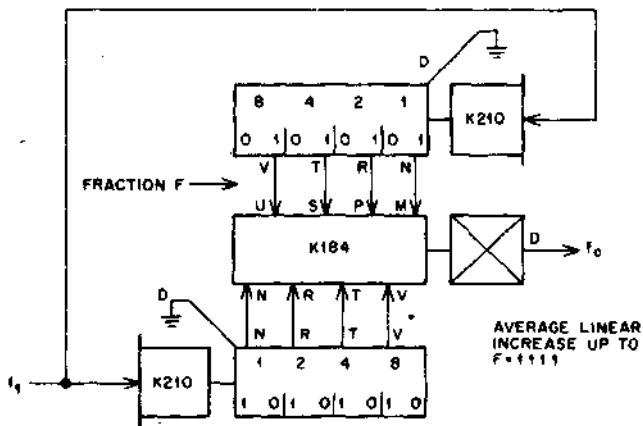

As shown below, if the FRACTION K210 overflows from 1111 to 0000,  $f_o$  will fall to zero and begin again to increment as before. The result is a Digital Sawtooth generator.  $f_o$  against time  $t$  is shown here.

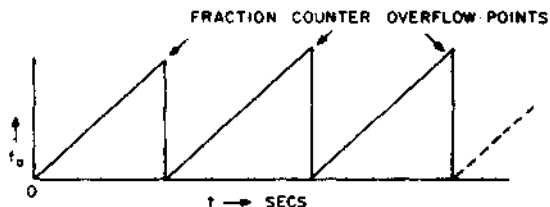

Resolution can be increased by module cascading. If the Fraction Counter is a K220 UP/DOWN Counter connected for Binary operation,\* then the slope of  $f_o$  can be reversed and controlled symmetrically.

\*(Pins BD, BE grounded)



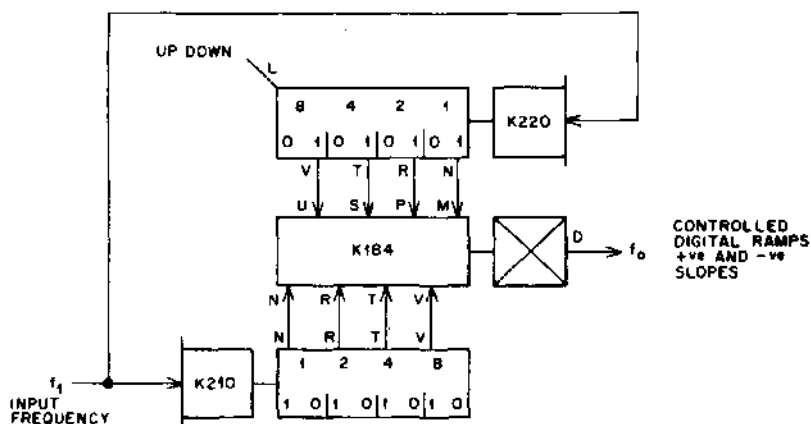

The output of the K184 shown above, is on the average, a linearly increasing frequency when the K220 counts UP, and a linearly decreasing frequency on K220 count DOWN. This facility is of use in controlling Stepping Motor Acceleration on K220 UP counts, and Deceleration on DOWN counts. The Fraction Counter must not be allowed to overflow.

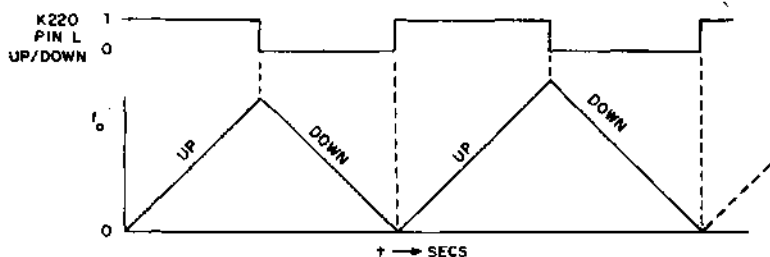

The response of  $f_o$  shown above is average and must be smoothed digitally to remove unacceptably large variations in pulse spacing; which would cause for example a Stepping Motor to change velocity instantaneously during the Acceleration period.

For more on rate multipliers, see references on K184 data page.

## SERIAL ADDER

When speed is not paramount, one can sum the contents of two K230 shift registers, A and B, bit-by-bit at low cost. The result can go back into one of the source registers.

Clock output CLK, 1 to 0 transitions, shift serially the addend and augend contained in K230 Shift Registers, A and B. The contents of the Registers are serially summed with the Carry In bits from the Carry flip-flop.

Carry Out signals, and CLK signal 1 to 0 transitions, cause the Carry Out flip-flop to be Set or Reset, ie Carry or No-Carry.

A	B	carry in	sum	carry out
0	0	0	0	0
1	0	0	1	0
0	1	0	1	0
1	1	0	0	1
0	0	1	1	0
1	0	1	0	1
0	1	1	0	1
1	1	1	1	

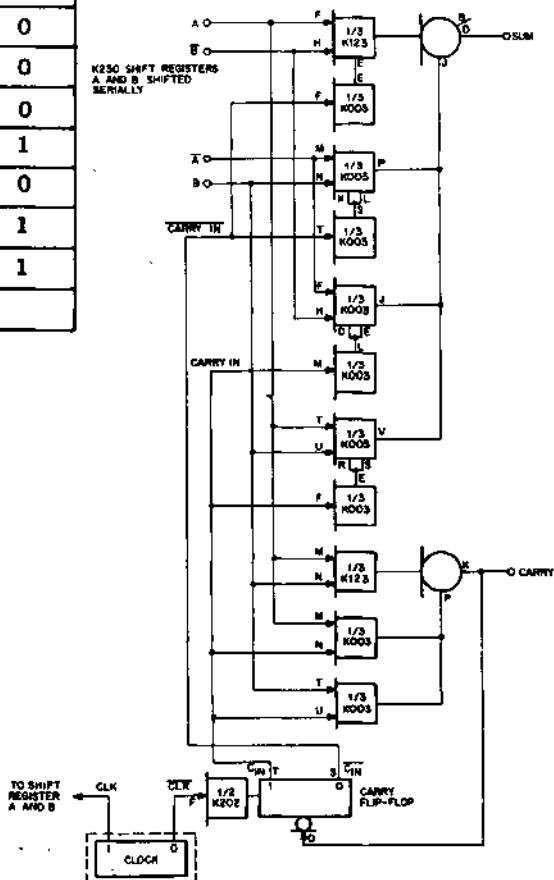

## STEPPING MOTORS

### INTRODUCTION

There are two fundamental parts to the design of any stepping motor drive system: Designing the logic for correct sequencing, and electromechanical design. Several logic designs are shown on the next few pages; here first is a brief discussion of electromechanical aspects.

Much of the emphasis in stepping motor system design is on maximizing stepping rates. There are two components in maximizing stepper speed: Maximizing the rate of motor current rise and delay, and operating within the motor's limitations of torque, friction and stiffness during the critical acceleration — deceleration phase. Successful design results in accurate stepping with no missed or gratuitous steps.

To optimize the response speed of any magnetically operated device, a minimum requirement is that the ratio of circuit inductance to circuit resistance be less than the desired response time. Thus if response of 1 millisecond is required in a one henry winding, the total of winding, the total of winding resistance and series padding resistance should be greater than 1000 ohms. If this ratio ( $L/R$  or henries-divided-by-ohms) equals or exceeds the desired response time in seconds, electrical effects tend to be the dominant limitation on speed and override mechanical factors.

The design problem is complicated by the increase in winding inductance as motion is accomplished. The inductance at turnoff may be many times the inductance at turnon in efficient devices such as solenoids. However, many types of stepping motors are designed to achieve maximum performance at the expense of efficiency, and the inductance of these motors may vary only a negligible amount (less than 10%) as rotor position changes. Since inductance ratios are generally unpublished, the best approach may be to start with equal resistance and then measure the actual current rise and fall times, increasing the turnoff resistance if necessary later. (In all of this, the driving transistors are assumed to switch in zero time, as they respond in microseconds whereas  $L/R$  ratios are generally in the millisecond range.) The equivalent circuits below show both equal and unequal cases.

Where

- $R_e$ —External Resistance for Risetime improvement.
- $R_p$ —Padding resistor
- $V_s$ —Supply voltage
- $V_{ce}$ —Transistor collector voltage
- $L_M$ —Motor winding inductance
- $R_M$ —D.C. motor resistance.

Notice that during turnoff the switching transistor experiences a voltage equal to the supply voltage for the equal case, but larger than the supply voltage if additional turnoff resistance  $R_p$  is added. Since the voltage rating of the driver is the limiting factor on the minimum  $L/R$  that can be achieved with a given inductance, the ratio of drive transistor voltage rating to supply voltage should be adjusted as indicated below for optimum electrical response:

$$V_s = V_r \frac{L_M \text{ (on)}}{L_M \text{ (off)}} = \frac{R_M + R_e}{R_M + R_e + R_p} V_r$$

Operating within the stepper's limitations of torque, friction, and stiffness during acceleration and deceleration is trickier than it looks, especially since some crucial constant may be omitted from published specifications for the device. There is often the wish to avoid abrupt (full frequency) starts and stops to achieve maximum stepping rates. Often only one or two steps need to be slowed to achieve maximum acceleration error-free. Too gradual change in stepping rate can actually encourage errors if inertia is moderate and friction low, caused by an actual resonant reversal of rotation at some particular step.

All of the logic circuits shown on the next pages can be used with any clock rate profile. It is best, however, to use an abrupt start-stop system unless the need for ultimate performance warrants a full study of system dynamics, including the use of a tachometer on the stepper shaft to observe the effect of proposed frequency profiling.

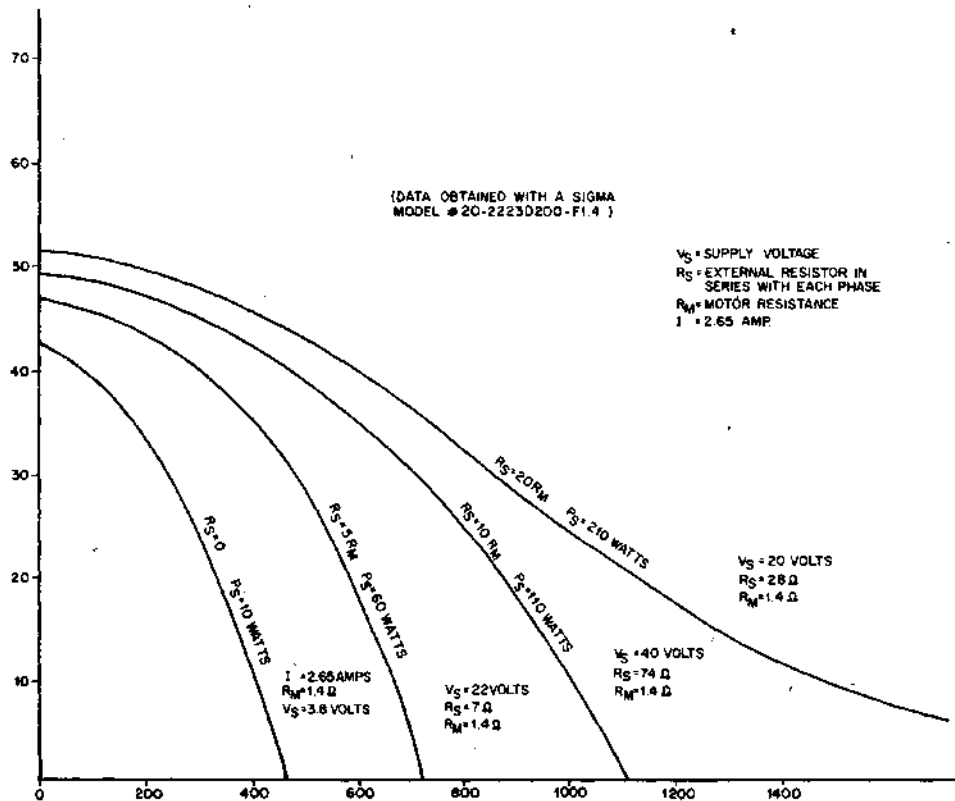

## SIGMA AND SLO-SYN\* STEPPER SEQUENCER

A K202 flip-flop module, connected as shown, forms a reversible switch-tail ring counter. With the "direction" input logic 1, 1 to 0 transitions on the "step input" index a bifilar stepping motor forward. With logic 0 on the direction input, the direction is reversed.

A d.c. driver controlled by the switch-tail counter provides power for the stepping motor.

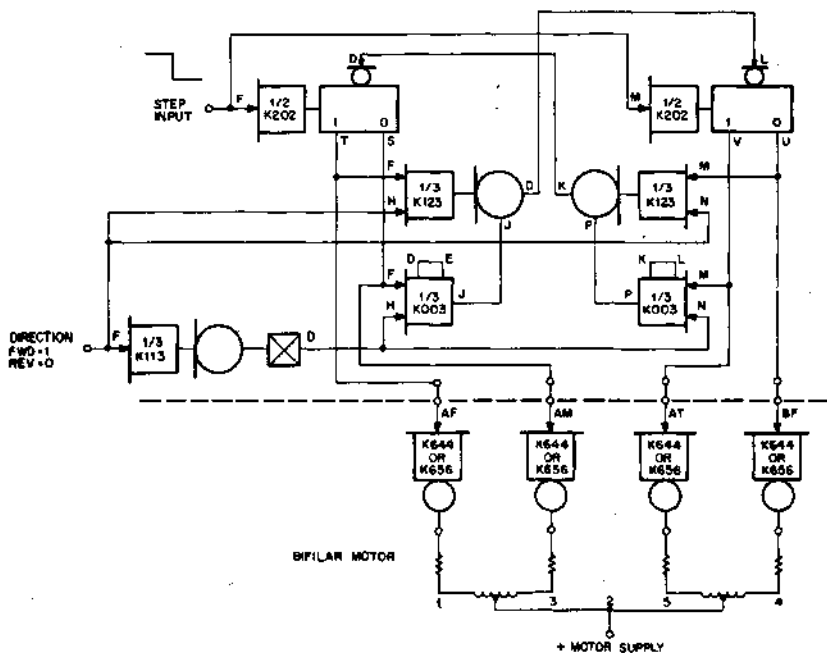

\*SLO-SYN is a trademark of Superior Electric Co.

## RESPNSYN® STEPPER SEQUENCER

This sequencer uses the same two bit shift register with inverted feedback as the SLO-SYN sequencer, but the outputs are gated to obtain the different drive pattern required by these motors.

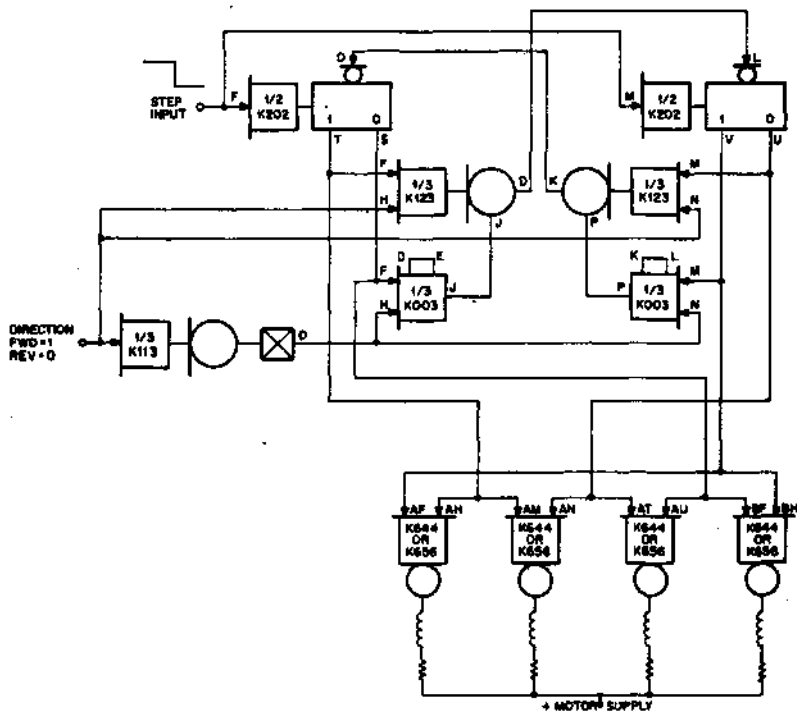

\*RESPNSYN is a trademark of United Shoe Machinery Corp.

## FUJITSU STEPPER SEQUENCER

FUJITSU Stepper motors can be driven forward and reverse, with the module arrangement shown. The table describes the stepping sequence required by a FUJITSU 5 torquer motor (with or without hydraulic servo amplifier).

STEP	A	B	C	D	F
0	X	X			
1	X	X	X		
2		X	X		
3		X	X	X	
4			X	X	
5			X	X	X
6				X	X
7	X			X	X
8	X				X
9	X	X			X



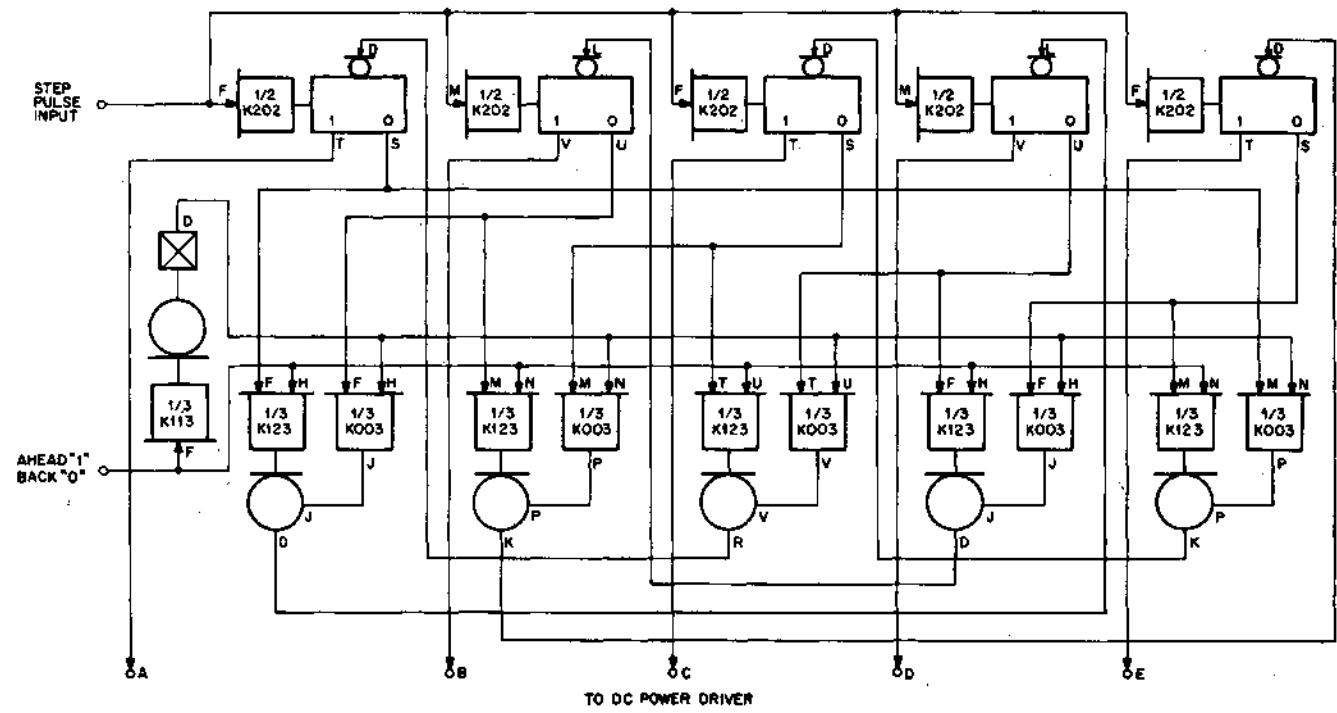

FUJITSU STEPPER MOTOR SEQUENCE.

## Electrohydraulic Servo Motors

Stepping motors are coupled to hydraulic servos to achieve increased torque at high stepping rates. Figure 1 describes in block form a typical open loop electrohydraulic servo. The fact that a closed loop feedback path in the electronics of this application is not required, is one of the technical and economic advantages of electrohydraulic stepping motors.

In applying electrohydraulic servos, the designer must consider matching the servo to its load to prevent overloading the motor. An overloaded motor can lose step pulses and cause a final position error. Figure 2 describes a typical equation for calculating load inertia: it is necessary that this load inertia never exceeds the servo rating. Also note in Figure 2 that two check valves are indicated between the input and output lines from the hydraulic supply. These check valves are used to prevent an extreme pressure from damaging a valve plate located within the hydraulic servo. This high pressure can exist from the spool valve closing over the input and output parts simultaneously and remaining in this position. Once a valve plate is damaged in the above manner, internal leaking is caused decreasing efficiency by requiring more input power to achieve the same torque which was obtainable prior to the plate being damaged.

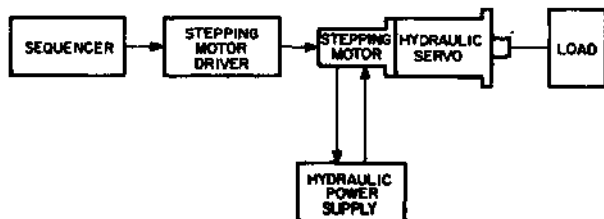

FIGURE 1.

### OPEN LOOP ELECTROHYDRAULIC SERVO USING STEPPING MOTORS

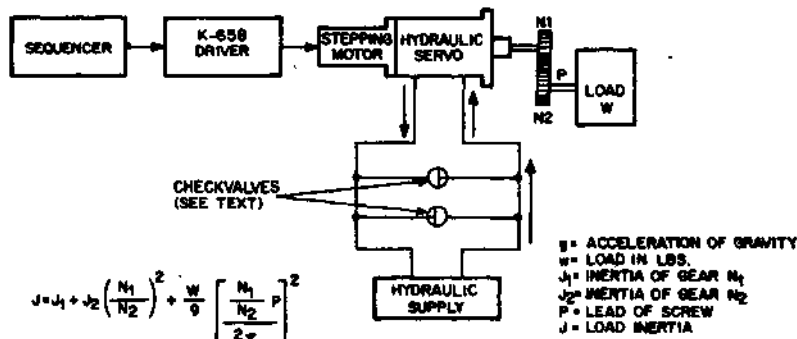

FIGURE 2.

## ANALOG-TO-FREQUENCY CONVERTERS

When a relatively slow-varying or constant analog signal must be transmitted some distance through noise, some form of current-to-frequency or voltage-to-frequency conversion is appropriate. There are really two distinct sets of benefits to be gained:

1. Analog noise will be averaged, and may be almost entirely nullified even if it is comparable to the signal in amplitude. Normally the frequency is sampled for an exact internal number of line-frequency cycles to average power frequency coupling to zero. High noise frequencies are mostly averaged out by the conversion device itself.
2. Digital noise will be averaged also, since one or two extra pulses or missed pulses represent a small fraction of the total number. In addition, the digital form of the measured quantity is inherently noise resistant since noise less than the switching threshold at the receiver has truly no influence whatever.

The improved transmissibility of analog data both before and after the conversion to an equivalent frequency has to be paid for in reduced speed of response to changes. (From the viewpoint of an information theorist, such a transmission mode would be said to deliver high redundancy and low information rate.) But many sensors on slowly varying processes which are distant from an associated digital system are ideally suited for this treatment.

The diagram below shows how an operational amplifier may be utilized to provide direct conversion from an analog voltage to an equivalent frequency with errors in the tens of millivolts. This scheme measures how long current in the input resistor  $R$  takes to charge the capacitor  $C$  ten millivolts. Each time this occurs, the output switches to the other state and discharges the capacitor rapidly.

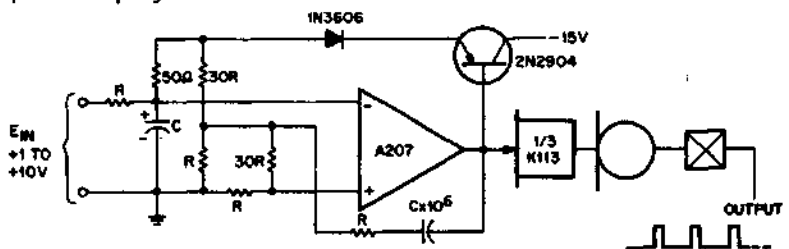

## VOLTAGE-TO-FREQUENCY CONVERTER

Resistance  $R$  should be about 1000 to 10,000 ohms to achieve a balance between error due to wide pulsewidth at high frequency and error due to the biasing effect of amplifier input current. To minimize the effect of amplifier switching time, capacitor  $C$  should be large enough (100 mfd with  $R=1000\Omega$ , for example) to limit maximum full-scale frequency to around one kiloHertz. Nearly any quality silicon diode and PNP transistor with at least 30 volt ratings could be used, and the small capacitor with its associated current limiting resistor is not critical either. Other components should be selected carefully to minimize drift and temperature coefficient.

K303 clock circuits can be modified by the additional parts shown below to achieve lower performance conversion at a saving. Basically, a current source controlled by the input signal being converted replaces the action of the timing resistor R shown in the Handbook diagrams. Transistors can be any high gain Silicon NPN type such as 2N2219.

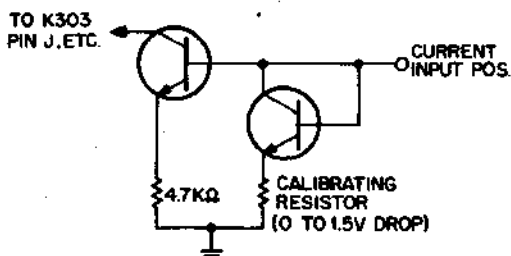

NOTE  
THE SMALL VOLTAGE  
DROP (1.5V MAX)  
AVAILABLE LIMITS  
LINEARITY TO  $\pm 5\%$   
OR SO FOR THIS  
CIRCUIT.

FOR POSITIVE INPUTS

If output frequencies are counted for an integral number of power-frequency cycles, clock filler will be compensated along with line frequency pickup on the analog leads.

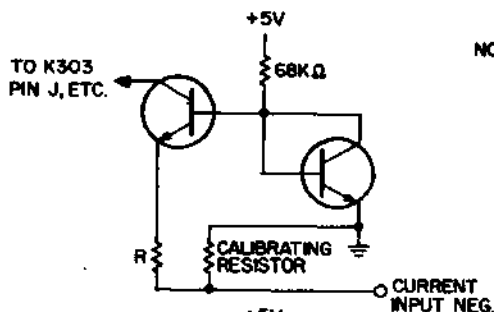

NOTE  
USE LARGEST PRACTICABLE  
VOLTAGE SWING. RESISTOR R  
SHOULD BE APPROXIMATELY  
3KΩ FOR EACH VOLT OF FULL-  
SCALE INPUT SWING. LINEARITY  
CAN BE IMPROVED TO ABOUT  $\pm 1\%$   
OF FULL SCALE BY USING  
INPUT VOLTAGE SWINGS  
UPWARDS OF 10 VOLTS.

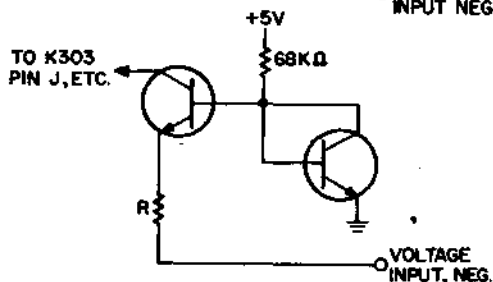

FOR NEGATIVE INPUTS

### USING K604, K614 WITH 240 VOLTS

These isolated AC switches have semiconductors and other components rated for 240 volt service. However, the Triac switches used were rated primarily for phase control applications. The difference is that some switching applications require an "off" switch to remain substantially off in the presence of transients and noise, without conducting for even one half of one cycle. Since a transient voltage, larger than the breakdown voltage of these devices (400 volts) can cause them to start and remain conducting until several milliseconds later when the load current returns to zero, the K604 and K614 contain transient-clipping devices across each circuit which go into conduction between the peak voltage of a 120 volt line (200 volts) and the Triac break-over voltage (400 volts).

Triac switches are not readily available at present with breakdown ratings above 400 volts. However, K604 and K614 switches can successfully be used in 240 volt service if two types of application are distinguished:

1. **Critical loads:** For example, a hydraulic solenoid valve controlling the liquid metal on a die-casting machine, an ignition transformer on a process boiler, a trip solenoid on a punch press; any use involving both fast response and a potential safety hazard. For such applications, two circuits should be connected in series, so that any undesired conduction will be limited to the actual duration (usually microseconds) of a transient or noise spike. Wiring K614 outputs in series is simple because two terminals are provided on each circuit. To put K604 outputs in series, use K782 terminals or see K716 data page for connector cable information. Note indicator lamp connections in diagram below.

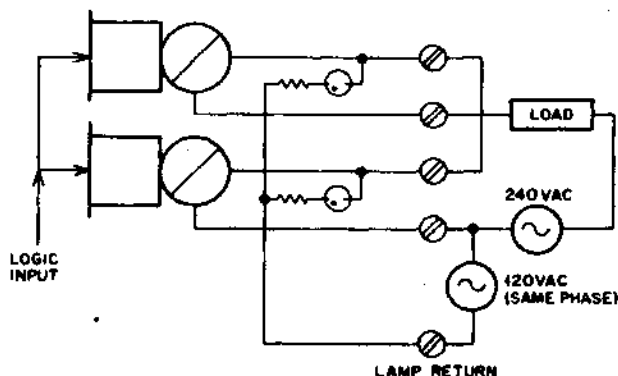

SERIES CONNECTED AC SWITCHES

2. Uncritical loads, where spurious conduction for several milliseconds could not be damaging or hazardous. Since the other components are rated for 240 volt service already, simply remove the transient-clipping varistors. These are axial-lead-devices with a black body and metal end-caps, about 2 cm long and 8 mm diameter. Lamp return voltage may be supplied from the load common (240 volts) if a rectifier diode is provided to obtain half-wave operation. In a system containing both modified and unmodified circuits segregate and mark them. Use of unmodified units with 240 volts directly will destroy them by grossly overheating the varistors.

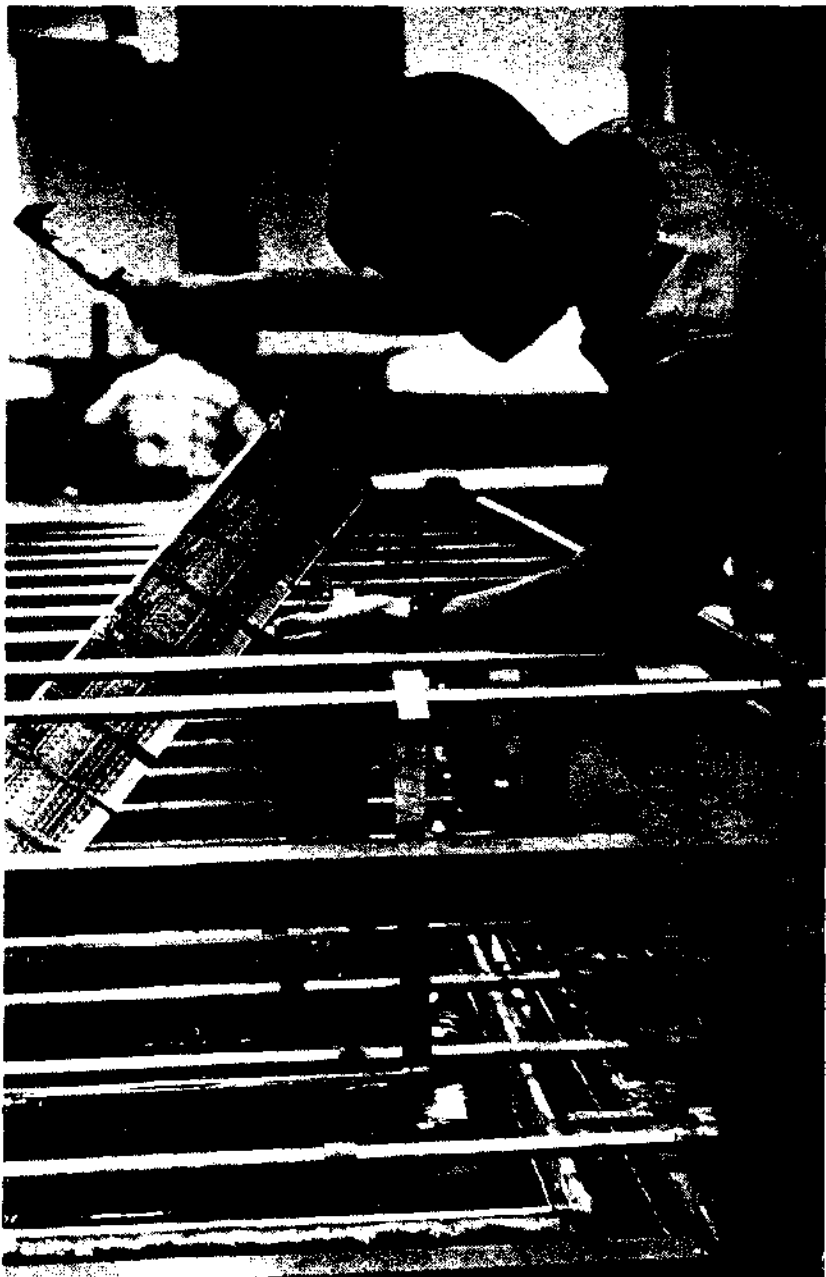

Checking the appearance of board contacts being gold-plated. Our 100 micro-inch plating is verified by periodic checking on a radiation gauge.

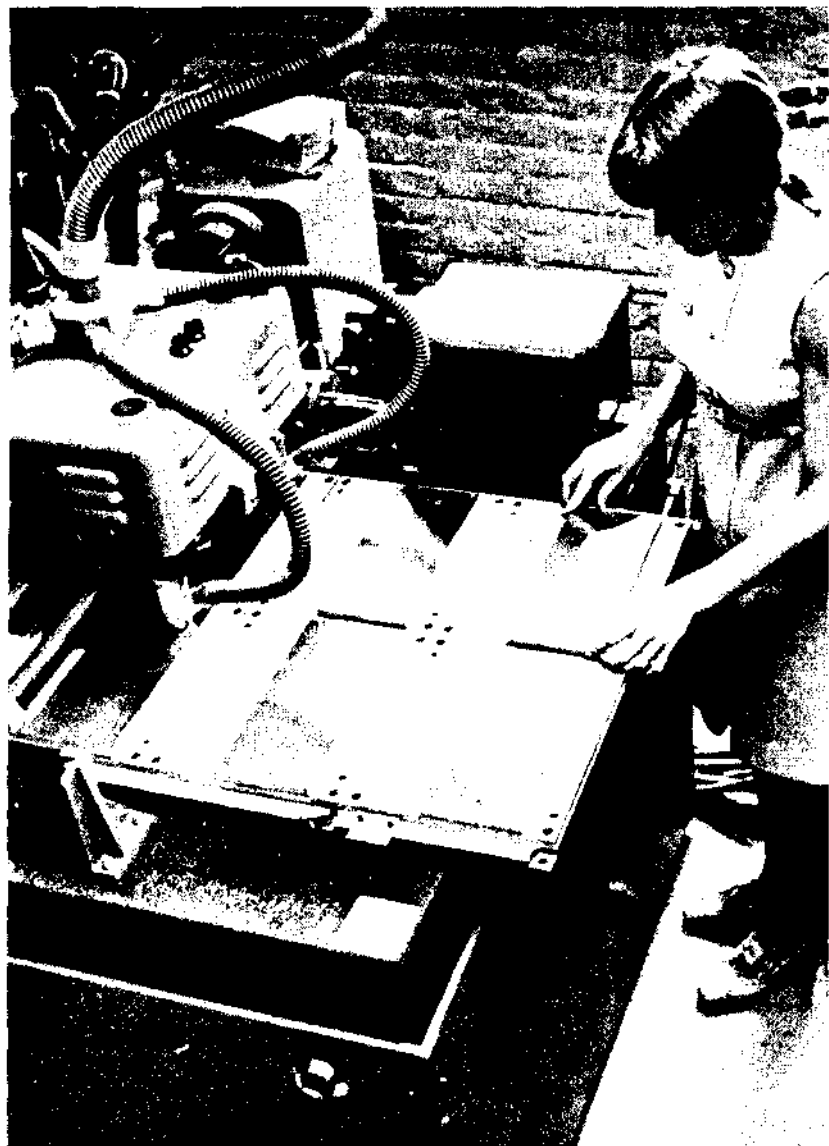

Twenty module boards are drilled simultaneously from a computer-generated coordinate tape. Other pantograph-controlled machines drill up to 200 boards simultaneously from a computer-generated template.



# Control Products



DIGITAL has been supplying the industrial control market with logic modules and computer products for more than 10 years. In mid-1969 the corporation formed the Control Products Group to focus attention on meeting the needs for advanced industrial control systems. Its organization is such that it provides the most effective use of our resources in developing new products and application techniques necessary to achieve this goal.

At present, the Control Products Group is comprised of three product lines, and a special systems group. The product lines are: Numerical Control Products, including Quickpoint-8 and our new DNC system; PDP-14 programmable controller; and Module Products, including training aids. The Control Systems group serves the product lines primarily in a design and manufacturing capacity, and draws upon other resources in the corporation in developing specialized control systems for our customers.

The following pages describe the major products, aside from logic modules, available from the Control Products Group. The K Series logic line is described fully in this handbook. Our other lines of logic modules, used primarily for computer/instrument interfacing and design, are described fully in the DIGITAL Logic Handbook. The Logic Handbook is free . . . send for your copy.

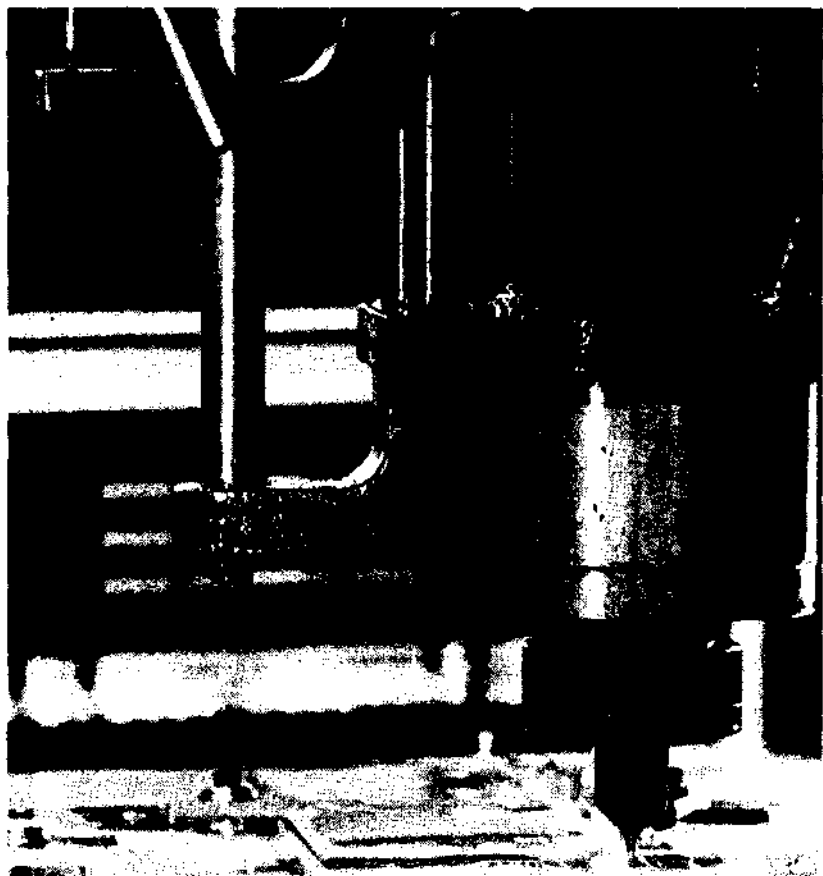

## NUMERICAL CONTROL PRODUCTS

DEC's products for numerical control consist of two basic systems designed primarily for builders of relatively simple two and three axis machine tools and related equipment. These include: punch presses; drilling/milling machines; simple lathes; flame cutting machines; and component assembly equipment.

The products, both computer based, are: Quickpoint-8, a system designed for low-cost, easy, and quick preparation of punched tape for NC machines; and DEC's new DNC system, designed for direct computer control of basic machines. Both products are based upon DEC's PDP-8 family of small general-purpose computers.

All suppliers of general purpose NC punch presses in North America now offer Quickpoint-8 or a related system. A growing number of machine tool builders offer a variety of DNC systems based upon PDP-8 or PDP-11 computers. UNIAPT and other powerful part program preparation languages have been written for these computers as well.

While Quickpoint-8 and DEC's new DNC system are designed for the low end of the cost/performance spectrum, DEC welcomes the opportunity to assist machine builders to develop computer control capabilities at any level of sophistication.

In addition to providing a general presentation of our NC products, the following pages should provide a basic insight into the role of the small computer in NC.

# Quickpoint-8

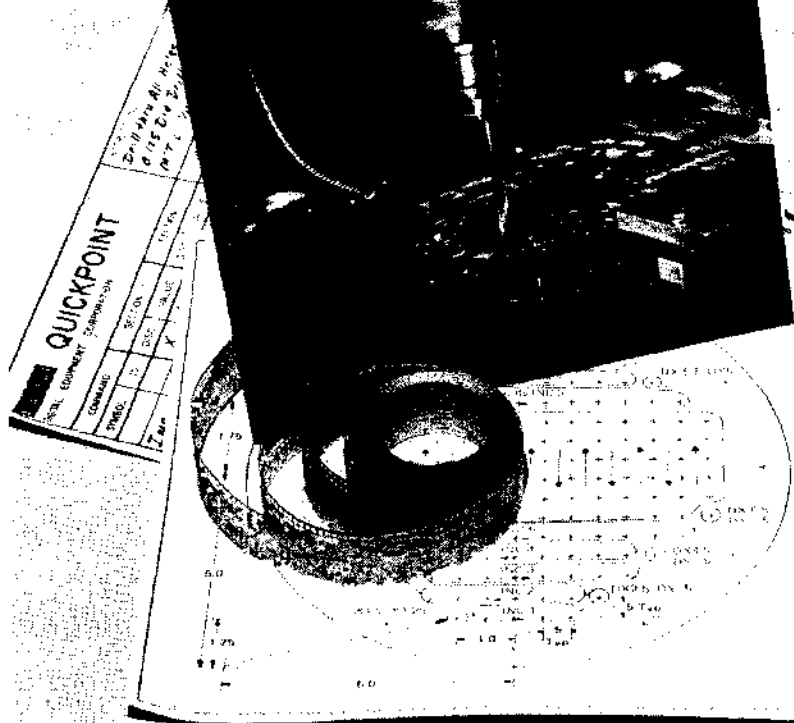

Quickpoint-8 is a point to point DEC language designed to make two or three axis NC tape preparation "quick" and easy.

## QUICKPOINT-8 NC TAPE PREPARATION SYSTEM

CONTROL  
PRODUCTS

Companies using numerically-controlled machinery must be able to produce or obtain NC tapes quickly and accurately in order to realize the full advantages of NC efficiency and economy. Without this capability, the competitive advantages of NC can dwindle rapidly. The Quickpoint-8 system is a low-cost, computer-assisted, part program compiler. Using this system, part programs can be prepared directly from the information supplied on conventional drawings in a fraction of the time required for manual programming, and with fewer errors. Error-prone, time consuming, manual calculations and intermediate processing are eliminated. The system is compatible with NC point-to-point machine tools, ranging from simple two-axis drilling machines to more complex three-axis machining centers. A perforated tape, punched in EIA character code and machine control format, is produced directly from the system's PDP-8 computer without the aid of intermediate conversion equipment.

The Quickpoint-8 system offers the following special features and advantages:

- Minimizes EIA paper tape preparation time by accepting input data directly from a teletype keyboard.
- Provides inexpensive pre-production quality control by reducing the probability of human error.
- Computes absolute or incremental X and Y coordinates (depending on control specifications) from either absolute or incremental values.
- Accepts decimals, fractions and mixed numbers in any combination.
- Adds and subtracts absolute and incremental numerical values without intermediate calculations or conversion.
- Accepts all auxiliary machine functions commonly available on multi-axis point-to-point machine tools.
- Computes coordinates from shorthand symbols that define commonly used geometric patterns (for example, bolt hole circles, arcs, grids, and incremental lines). Up to 4095 coordinates can be computed from a single command.
- Stores and repeats recurring random or geometric pattern definitions for reuse in present or future part programs.
- Accepts and prints out editorial corrections, program comments and machine operator's instructions.
- Automatically punches the completed part program, including auxiliary machine functions, on paper tape in EIA character code and machine control format.
- Accepts input data programs punched on paper tape in ASCII character code and format.
- Uses a single, easily learned language for a wide variety of machines.

## SYSTEM DESCRIPTION

A minimum Quickpoint-8 system is comprised of: a general purpose PDP-8 computer with core memory of 4,096 12-bit words; a Quickpoint program with postprocessor; and a teletypewriter for input/output. The teletypewriter includes an alphanumeric keyboard, a tape reader, a tape punch and a line printer. (Model ASR33 Teletype is suitable for light-duty use. For heavy-duty use, a model ASR35, or a backup ASR33, is recommended.)

The operating speed of the teletypewriter is 10 characters per second. An optional high-speed paper tape reader increases the reading speed to 300 characters per second for such applications as faster interchange of post-processors.

Because the Quickpoint-8 system uses a general purpose computer, conventional data processing tasks such as machine loading and production control can be accomplished when the system is not being used for compiling part programs.

## THE QUICKPOINT LANGUAGE

The Quickpoint language comprises a limited number of easily learned operating procedures. The main purpose of the language is to permit direct transfer of information from part drawings to input data preparation, and to instruct the system to run, operate in different modes, and accept changes. The language also allows the system to notify the parts programmer of language or programming rule violations. Included in Quickpoint are coordinate commands, geometric pattern commands, pseudo commands, pattern commands, auxiliary function commands, error messages, and general format rules.

Following are a few examples of commands the system can execute. The power of these commands is evident in that geometry can be described directly from print data for point-to-point and as well as for some two-axis profiling without the need for separate calculation on the part of the parts programmer.

### Geometric Commands

**INC INCREMENT:** Allows incrementing along X or Y axis by specifying, in order, direction (R, L, U, or D for Right, Left, Up, or Down), increment (distance between holes), and number of holes.

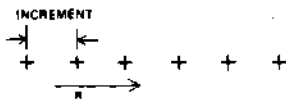

**LAA LINE AT ANGLE:** Allows incrementing along a line at an angle to the X axis by specifying, in order, the increment value, angle, and number of holes.

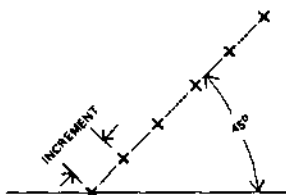

**BHC BOLT HOLE CIRCLE:** Allows for computation of bolt holes by specifying, in order, the radius of circle, angle from X axis of first hole, and number of holes.



**ARC ARC:** Allows for computation of holes along an arc by specifying, in order, the radius of arc, angle from X axis of first hole, incremental angle between holes, number of holes.

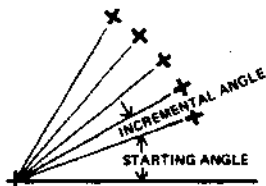

**GRID GRID:** Allows for computation of holes in a grid pattern by specifying in order, direction, increment, and number of lines of each axis.

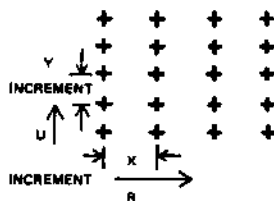

### Pattern Commands

Pattern commands allow the parts programmer to make up his own random pattern consisting of both geometric commands and incremental coordinates. By numbering these patterns, he may reuse them over and over by merely calling them by their assigned number. Patterns may be combined to define larger patterns.

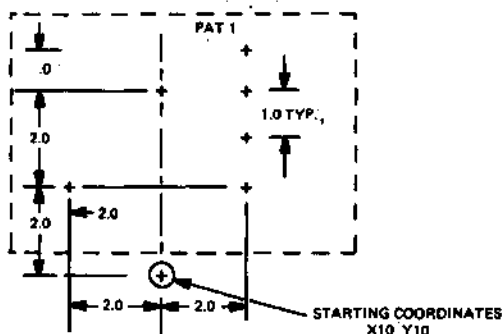

For instance, to define a pattern of random holes, the operator types PAT with an identifying number. All coordinates and geometric commands which follow are included in the pattern definitions until an END command is typed. For example:

```
X10.0 Y10.0
PAT1/
DX-2.0 DY2.0
DX2.0 DY2.0
DX2.0 DY1.0
INC/ D 1.0 3
END<PAT1
```

To repeat a pattern, new starting coordinates are typed and then the PATTERN command is retyped.

```
X20.0 Y10.0
PAT1
```

Pattern 1 will be repeated starting at X20 Y10.

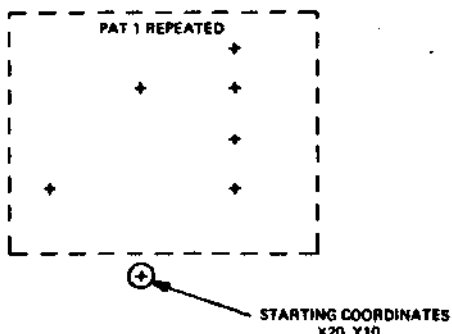

Patterns may be defined within patterns and previously defined patterns may be used to define new patterns—for instance:

```
PAT3/
DX2
PAT 1
END<PAT3
```

Pattern 3 consists of Pattern 1 which was previously defined.

### Profiling

Quickpoint-8 also allows the programmer to prepare tapes for profiling on point-to-point machines using the bolt hole circle, arc and line-at-angle commands. In all geometric commands the number of holes specified may be any number from 1 to 4095 and any angular dimension can be as small as .001.

By combining various arc commands and line-at-angle commands, profiles can be generated to accommodate many shapes. In addition, contour nibbling for NC controlled punch presses can be more efficiently programmed.



, to profile a radius with a tool diameter of .5":

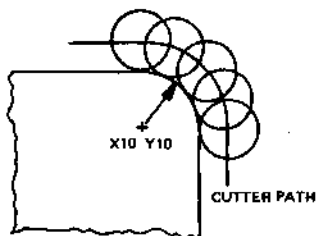

MOV/ X10.0 Y10.0

(starting coordinates of ARC command)

ARC/ .75 0 1.0 90

The radius equals the part radius plus  $\frac{1}{2}$  tool diameter. Ninety (90) holes are computed at 1 degree increments, creating the 90° arc.

### QUICKPOINT APPLICATION

This aluminum filter plate is typical of a two-axis point-to-point drilling job for which Quickpoint is well suited. Manual calculations of the coordinates for 180 of the 192 hole locations requires simple addition. The remaining dozen, however, are in a circle, whose coordinates require some trigonometry for solution. Manual programming is relatively simple, but it is also repetitious and time consuming, in addition to creating 192 possibilities for errors in calculating or punching tape.

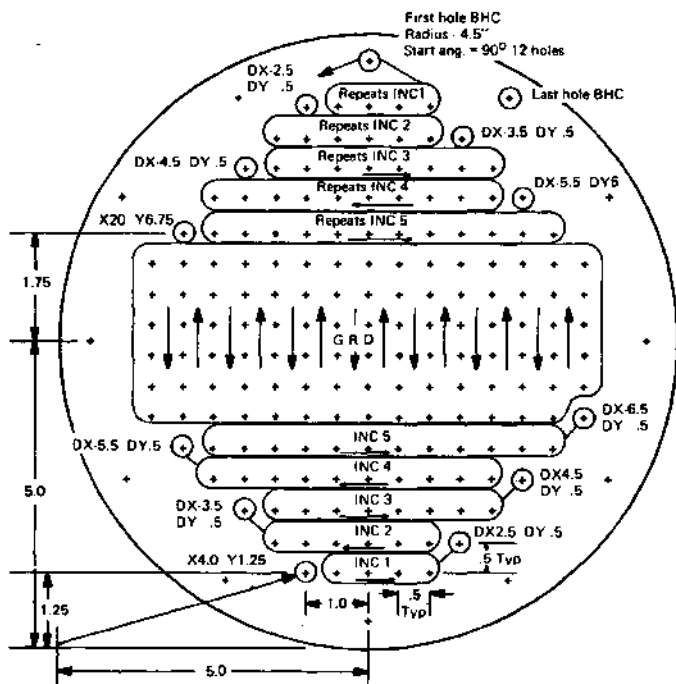

192-Hole Drilling Application for Quickpoint

Quickpoint-B does the job in 25 statements as shown in the manuscript. A printout of the Quickpoint input tape created from the manuscript is also shown. A single pass through the Quickpoint system can produce an output tape ready to be inserted in the machine tool.

QUICKPOINT DIGITAL EQUIPMENT CORPORATION		INSTRUCTIONS: DRILL THRU ALL HOLES 0.125 DIA DRILL, 0.125 1/4 ANCH			DRAWING NO. 043721-4 DESCRIPTION FILTER PLATE	PAGE 1 OF 1 DATE 4/30/68 PROGRAMMER R.B. LANCASTER
GEOMETRIC COMMAND	ID	X-COORDINATE OF GEOMETRIC DATA	Y-COORDINATE OF GEOMETRIC DATA	Z-COORDINATE OF GEOMETRIC DATA	ANNUALARY FUNCTIONS	COMMENTS
		X 4.0	Y 1.25			ABSOLUTE LOCATION OF FIRST HOLE
INC	1/	R	.5	HOLES 4		DEFINES AND STORES INC 1
		DX 2.5	DY .5			
INC	2/	L	.5	HOLES 6		DEFINES AND STORES INC 2
		DX -3.5	DY .5			
INC	3/	R	.5	HOLES 8		DEFINES AND STORES INC 3
		DX 4.5	DY .5			
INC	4/	L	.5	HOLES 10		DEFINES AND STORES INC 4
		DX -5.5	DY .5			
INC	5/	R	.5	HOLES 12		DEFINES AND STORES INC 5
		DX 6.5	DY .5			
GRD /		U .5	HOLES 5	L .5	HOLES 14	DEFINES GRID
		X 2.0	Y 6.75			
INC 5						REPEATS INC 5
		DX 6.5	DY .5			
INC 4						REPEATS INC 4
		DX -4.5	DY .5			
INC 3						REPEATS INC 3
		DX 2.5	DY .5			
INC 2						REPEATS INC 2
		DX -2.5	DY .5			
INC 1						REPEATS INC 1
MOV	/	X 5.0	Y 5.0			ESTABLISHES CENTER OF BOLT HOLE CIRCLE
BHC	/	RA 4.5	SA 90	HOLES 12		DEFINES BOLT HOLE CIRCLE
		X $\phi$	Y $\phi$	R $\phi \phi$		END

Quickpoint Manuscript

```

< FILTER PLATE
< DWG. NO. 043721
< DRILL THRU ALL HOLES
  Ø.125 DRILL
< MTL: 1/4 IN ALUMINUM
< R. LANCASTER APRIL 30, 1968
X4.Ø Y1.25
INC1/ R .5 4
DX2.5 DY.5
INC2/ L .5 6
DX-3.5 DY.5
INC3/ R .5 8
DX4.5 DY.5
INC4/ L .5 10
DX-5.5 DY.5
INC5/ R .5 12
DX6.5 DY.5
GRD/ U .5 5 L .5 14
X2.Ø Y6.75
INC5
DX5.5 DY.5
INC4
DX-4.5 DY.5
INC3
DX3.5 DY.5
INC2
DX-2.5 DY.5
INC1
MOV/ X5.Ø Y5.Ø
BHC/ 4.5 9Ø 12
XØYØMØØ
$

```

Input Tape Printout



A typical Quickpoint-8 system includes a PDP-8 family computer with tele-  
typewriter, low and high speed reader and high speed punch.

## **POSTPROCESSORS**

### **Standard Postprocessors**

A number of standard postprocessors for a variety of two-axis machine tools are available from DEC. To insure that the postprocessor meets the requirements of particular machines, customers should review specification sheets (see sample) available for each at no cost. Among the post processors available for the Quickpoint-8 system are:

- QF02-A for Pratt & Whitney A, B, and C
- QF02-B for Wiedemann with Cutler Hammer 902
- QF02-D for Wiedemann with GE 120
- QF02-E for Cincinnati Drill & Mill with Acramatic 220
- QF02-F for Cleereman Drill & Mill with GE 120
- QF02-G for W. A. Whitney Turret Punch Press with Westinghouse
- QF02-H for Behrens Turret Punch Press with GE 120-II-500
- QF02-I for Burgmaster 2BHT6 Turret Drill with GE 120-II
- QF02-J for Wiedemann A-15 with GE Mark II Control
- QF02-K for Wiedemann # S-1528 with Warner & Swasey Control
- QF02-L for Brown & Sharpe Model A-1118 with GE Mark II
- QF02-M for Burgmaster 2BHTL with GE 120-II
- QF02-N for MOOG Model 83-500
- QF02-O for Wiedemann S-2540 Turret Punch Press with GE Mark Century 100
- QF02-P for Westinghouse #20 Control for a Behrens Turret Punch Press
- QF02-Q for Pratt & Whitney control for Pratt & Whitney 1000 NC Jigborer
- QF02-R for Sperry Rand UMAC6 control for Brown & Sharpe Hydrocutt Machining Center
- QF03-A for Superior Electric Control
- QF03-B for CIMX-330 Machining Center
- QF03-C for Burgmaster 3BHTL Turret Drill with GE 103P
- QF03-D for Brown & Sharpe Hydrotape #234 12 Station with GE 103P

FORMAT	DIMENSIONAL FORMAT	DIMENSIONS	GPR2-E
--------	--------------------	------------	--------

Word address, variable block	2.3	Absolute
------------------------------	-----	----------

This postprocessor was originally designed for an Acromatic 220 with a Cincinnati Heald Acra-center or a Cincinnati CIM-X machining center.

Teletype printout and computed coordinates for figure 4-1, User's Guide:

```

X1#  Y1#
H#01  X1#000  Y1#000
DX-2.#  DY2.#
N#02  X1#002  Y1#000
DX2.#  DY2.#
N#03  X1#000  Y1#000
DX2.#  DY1.#
N#04  X1#000  Y1#000
INC1/D  1.# 3
N#05  Y1#000
N#06  Y1#000
N#07  Y1#000
    
```

Characters are punched in EIA

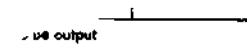

Approximately 18 characters per line. Characters not recognized or recognized by the postprocessor, remain for output top.

When H automatically precedes the sequence number. Whether or not X or Y data or auxiliary function (G or M) data is entered, X data, Y data, or any function, are input in this block. If no auxiliary function data is input, a G# will be output automatically. (If no data is entered no data will be output, either in the first block or in any other.)

2. Only one M or G function is output per block. Thus, if two M or G functions are input in a block, only the last M or G function will appear on the Teletype listing and be punched in EIA code on tape.
3. The "FBK" command may be put on a separate line or on the same line as any X, Y, G, M data. This command causes an H to be output before the sequence number. On all blocks except the first and those in which an "FBK" command was entered, an "N" will precede the sequence number.
4. Tabs are output between each sequence number, preparatory function, X data, Y data, and miscellaneous function (both on the Teletype listing and on the EIA tape).
5. An EOF (EIA code 2#) character is punched after each block of data on the EIA tape.
6. Auxiliary functions may be input alone on a block of data.

I have examined these specifications carefully to see that they meet the requirements for my machine tool and control. I have not relied on the name and model of my machine tool and control because I realize that small but significant variations are common.

Signed \_\_\_\_\_ Title \_\_\_\_\_ Company \_\_\_\_\_ Date \_\_\_\_\_

### Custom Postprocessor Service

When a standard postprocessor is not available, DEQ can prepare one based upon customer requirements. In such a case, the customer will be asked to provide detailed input via a specification questionnaire (see sample). He will also be required to provide a copy of his part programming manual.

#### POSTPROCESSOR SPECIFICATIONS

Due to the absence of standardized documentation and the great number of control and machine types, variations, and options, we must ask you to specify in detail the characteristics of your particular system. Please keep in mind that the computer will do exactly as it is told, whether or not its instructions suit your need.

**Machine:** Complete Type Number \_\_\_\_\_ Mfr. \_\_\_\_\_  
All Accessories, Options \_\_\_\_\_

Rotary Table NC controlled? \_\_\_\_\_ Other NC controlled 3rd axis? \_\_\_\_\_

How many positions in automatic changer or turret (if any)? \_\_\_\_\_ Total Travel X \_\_\_\_\_ Y \_\_\_\_\_ Z \_\_\_\_\_

**Control:** Complete Type Number \_\_\_\_\_ Mfr. \_\_\_\_\_ EIA  ASCII   
All Accessories, Options \_\_\_\_\_

Format: Tab Sequential  Fixed Sequential  Word Address  Variable Block

May Tab be used freely? \_\_\_\_\_ If not, what are the rules (check here if separate sheet used )?

May leader/trailer be blank? \_\_\_\_\_ May leader/trailer be rebut? \_\_\_\_\_

If neither, what must leader/trailer be? \_\_\_\_\_

Must first character of first block be End of Block \_\_\_\_\_ G80 \_\_\_\_\_ Other? \_\_\_\_\_

List any other required contents of first block, in the order in which they are required: \_\_\_\_\_

May leading zeros be omitted? \_\_\_\_\_

Must decimal point appear on punched tape? \_\_\_\_\_

Are dimensions absolute, incremental, or mixed? \_\_\_\_\_ a dimension

Are minus signs used? \_\_\_\_\_, r, S, or T functions

May dimensions that have not been defined be used? \_\_\_\_\_

If only part of the dimension is used, under what conditions? \_\_\_\_\_

**Auxiliary Functions:** \_\_\_\_\_ (if any) which can share a block with any auxiliary  
Please specify \_\_\_\_\_ dimension. If X, Y, Z, R, F, S, or T functions have

\_\_\_\_\_ prerequisites, exceptions, combining rules, etc. must be spelled out. Please be very  
specific; any rule not stated, will probably be violated by the postprocessor, especially when the  
stored pattern capabilities of Quickpoint are utilized.

(Check here if separate sheet used  )

Signature of Customer \_\_\_\_\_ Date \_\_\_\_\_

So that we may check for requirements not covered in this specification we require that it be accompanied by a copy of your part programmer's manual, together with a copy of any and all manuals, reports, etc. that may be referenced therein. Until we have complete data, we cannot quote.

### Sample Postprocessor Questionnaire

## QUICKPOINT ADVANTAGES

### vs. Time Sharing

The primary advantage of Quickpoint-8 versus time sharing is cost. As shown in the accompanying graphs,\* the moderate-to-heavy user of time sharing can realize a breakeven point with a Quickpoint-8 system in two years or less. This is achieved with as little as two hours per day use.

In addition to the cost advantage, an in-house Quickpoint-8 system offers these distinct advantages over time-sharing:

- instant access to the computer (no busy signals, queuing, or disconnects)
- no long-distance phone line charges
- system control and software security
- cost stability (the initial low-cost investment can be written off in fixed regular amounts and is not subject to cost peaks and valleys based upon usage)

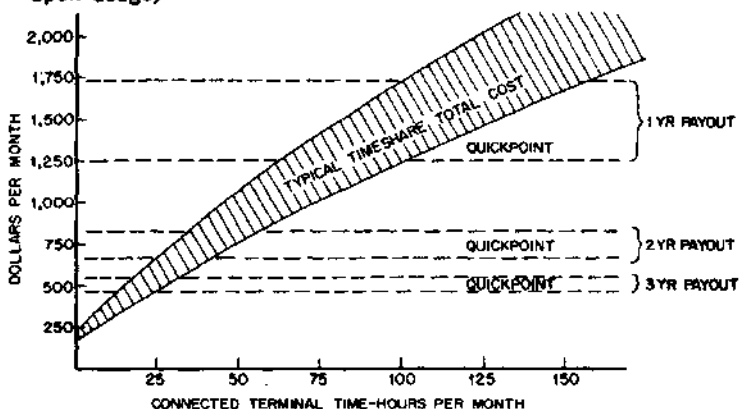

\*Based upon information published in COMPUTER-AIDED PART PROGRAMMING FOR NUMERICAL CONTROL, AN INDUSTRY STUDY, by John D. McCarroll, Industrial Development Division, Institute of Science and Technology, the University of Michigan, 1969.

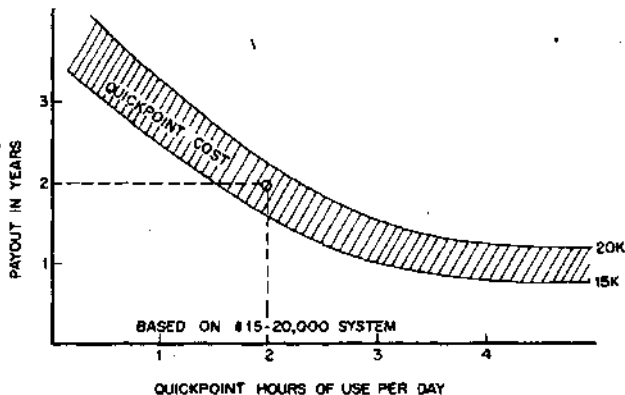



### **vs. Manual Programming**

Quickpoint-B offers three distinct advantages over manual methods of parts programming: accuracy, simplicity and time savings. These can mean real cost savings over a period of time.

#### **•ACCURACY**

Manual methods can sometimes involve three or four attempts before a correct tape is punched. This leads to wasted materials and machine time.

Trigonometric and pattern commands are performed by the computer thus avoiding human computation error. This further minimizes first part problems.

Error commands alert the programmer to certain kinds of format mistakes, thus preventing those errors from spoiling a part (faster proveout).

#### **•SIMPLICITY**

Quickpoint simplifies the calculations required by manual methods, and standardizes codes and formats needed for each machine/controller combination.

The simplicity of the language enables the part designer to learn to make his own first-part tape, thus reducing the time between product development and prototype production.

#### **•TIME SAVINGS**

Programming time is effectively halved.

With additional teletypewriters, several programmers can be served at less cost than by adding flexowriters.

By using the Master Tape Duplicator program with the high speed tape options, a fresh working tape can be generated quickly for each job run, thus avoiding the chances of worn or obsoleted tapes spoiling the work.

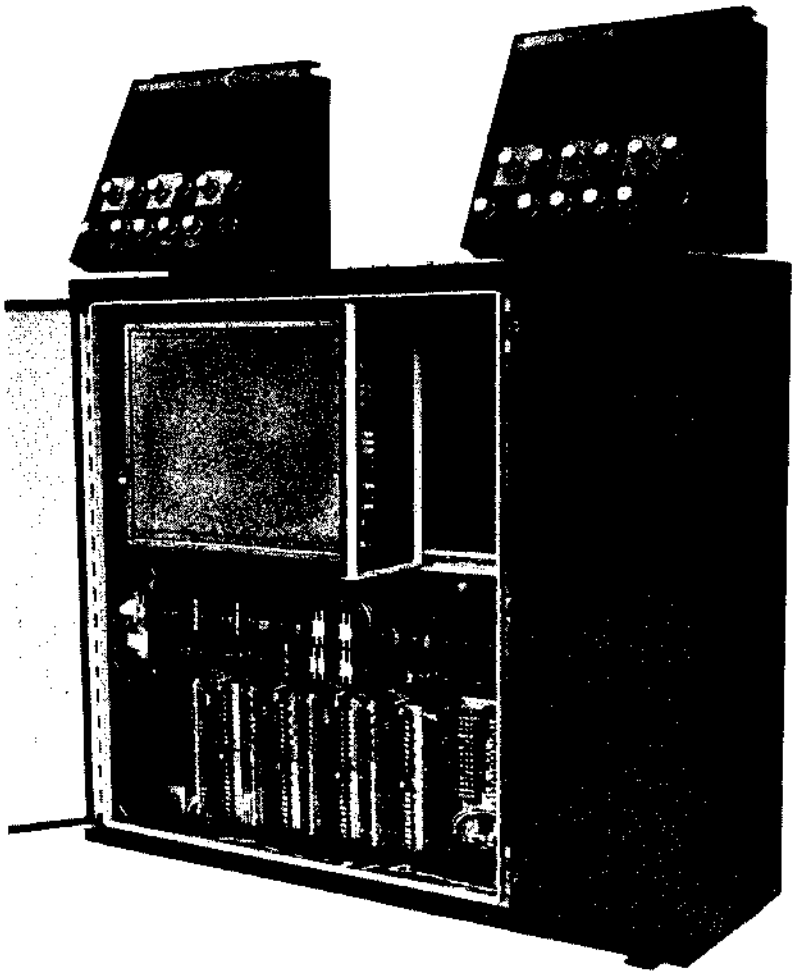

DEC's new DNC system includes a PDP-8 family computer and interfacing housed in a NEMA enclosure, two operators' consoles, and three teletype-writers (not shown in this photo).

Until now, a broad range of standard DNC products has not been commercially available. Each machine tool builder who wanted to exploit the potential of computer NC had to spend considerable effort in developing specifications appropriate to his particular customers' requirements.

In response to this situation, DEC has developed a modular DNC system based on the popular PDP-8 family of low cost computers. To date the largest number of dedicated general-purpose computers connected directly to metalworking, component assembly, and measuring machines have been supplied by DEC. An even greater number of PDP-8 family computers are in daily use preparing part programs to run conventional NC systems.

The new PDP-8 based DNC system is of the most basic design. It is modular to meet varying needs of machine tool builders, and is planned to serve as a basic building block for DNC applications in machine tools as well as other manufacturing equipment.

The system is priced near the bottom of the cost spectrum to allow those with even modest needs to obtain the advantages and power of direct numerical control.

Besides offering a basic DNC system, DEC's NC products staff will assist machine builders in not only defining special requirements, but in developing special hardware and software, directly or through a third party systems company.

## **GENERAL DESCRIPTION**

### **HARDWARE CONFIGURATION**

The DEC DNC system comprises a 4K PDP-8/L with various interfaces, three ASR33 Teletypes, an oil-tight enclosure with two integral oil-tight operator consoles, and space to mount interfaces for several types of readily available stepping motors. It is designed to be placed between two similar machines running independent part programs, and controlled by the same or by different operators.

### **SOFTWARE**

The DNC software package comprises a foreground/background system with routines for linear and circular interpolation, cutter radius compensation, part program preparation, supervisory report generation, machine slide program dimension changes, etc.

### **DRIVE SYSTEMS**

Electro-hydraulic pulse motors or all-electric steppers may be interfaced by selecting different hardware and software modules.

### **POWER SYSTEM REQUIREMENTS**

Total power requirements for the system: 220/230 volt, single phase, 50/60 Hz. This power is provided to the enclosure by receptacles in a non-interchange-

able scheme. That is, one receptacle is furnished for a regulated 115/120 volt, 3 wire, single phase input as a logic power source. The other receptacle is a four wire device requiring 220/230 volts, single phase power for motor and auxiliary function loads.

All inputs are filtered internally in the enclosure to minimize line transients and noise. A voltage stabilizing transformer 120/220 volt 50/60 Hz must be supplied by the user for the regulated input. Each plug is furnished with mating receptacle for ease of installation.

### ENVIRONMENT

The main system is designed for self-cooled operation where men are comfortable, or at higher temperature with an added vortex cooler. Enclosure and control consolettes are NEMA 12 type welded steel gasketed, with oil-tight pushbuttons. There is no interchange of shop atmosphere, no filters to get clogged. Teletypes are used by supervisor and part programmer but not by machine operators, and need not be exposed to severe environments adjacent to the machines.

### REDUCED CONFIGURATIONS AND SUBSYSTEMS

Both hardware and software are modular. Single-machine configurations with one operator's console and two teletypes are available, and may be upgraded to twin systems later. Subsystems and software are available separately without field service support for those who wish to develop their own systems.

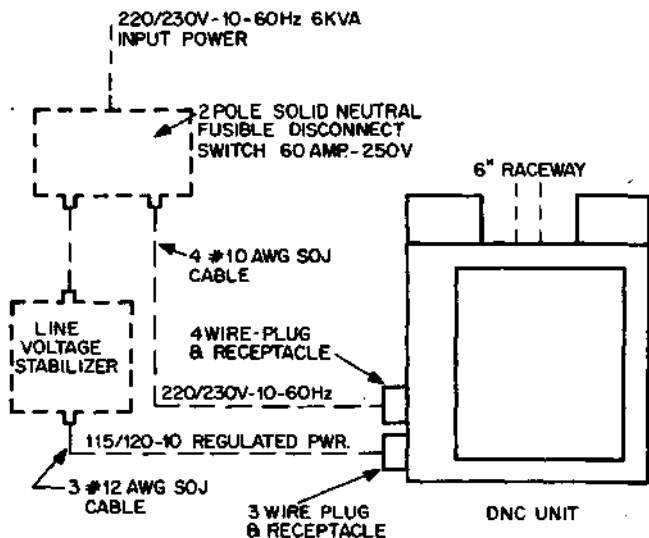

NOTE:  
1. ALL UNITS SHOWN DOTTED  
ARE USER SUPPLIED

TYPICAL SITE INSTALLATION  
FOR DNC SYSTEM.

DNC POWER SUPPLY

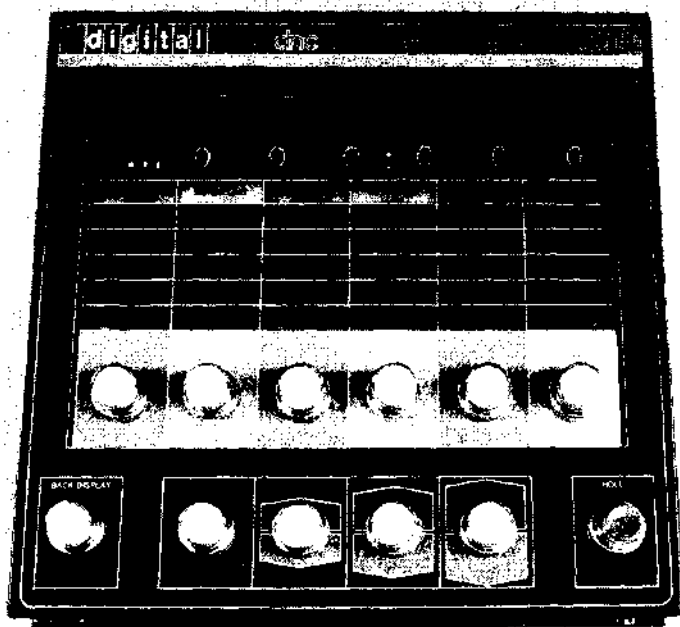

Operator's interactive console of DEC's new DNC system.

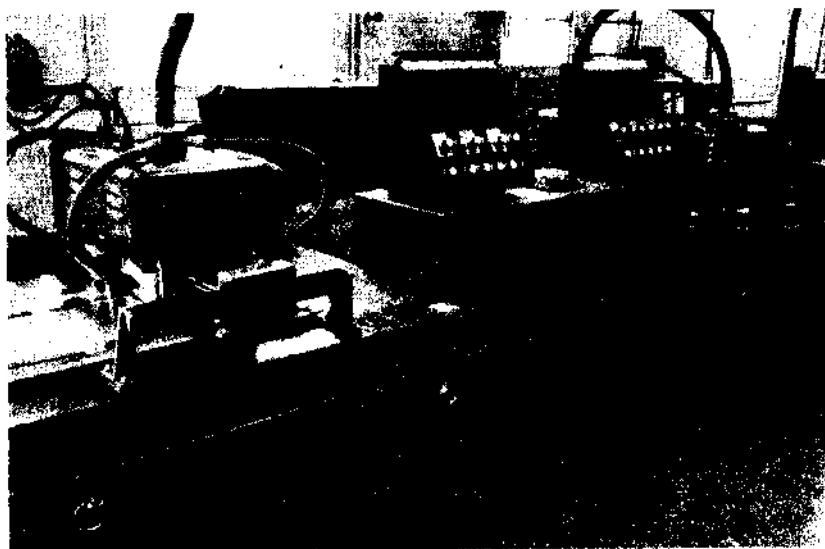

A typical application of DEC's new DNC system.

## DNC SOFTWARE

### Part Program Formats

#### IDENTIFICATION INPUT

At the beginning of part program preparation the computer types a slash, after which the part programmer may enter any characters he chooses to represent identification. This input is terminated by another slash.

/ DEC-3781-6A-768-R2-21/

Note: Underlined characters provided by computer.

#### PART INPUT

By hitting "X," the programmer selects the format for specifying a new target position. A typical interchange might be:

026 X2.75 -1.2 Y +23.6780 R2.25 +1 Z +

The programmer in this example has:

- Subtracted 1.2 from 2.75 to get X=1.55
- Added 23.6780 to the previous Y location
- Specified a new R plane at +3.25 inches
- Left the Z dimension as it was

#### PATTERNS

By hitting "P," the programmer selects the format for defining a section of the part program already completed as a pattern to be repeated:

043 P#6 +25

The programmer in this example has specified a repeat of all the sequence numbers starting with 6, and ending with the last sequence number before 25.

#### AUXILIARY FUNCTIONS

By hitting "M," the format for specifying auxiliary functions is obtained:

103 M13M +154 G81R

The part programmer in this example has provided CW spindle power and coolant #1, called for a tool change, and specified a new canned cycle (drilling). He has rejected the opportunity to specify a second M function. (He could have rejected G and/or T as well, of course.)

If one of the circular arc functions (G02, G03, G06, G07) is specified then an opportunity to specify the radius of the arc is presented.

136 M +120 G02R.75

In this example the part programmer has specified:

No new M function.

A change to tool 20. The nominal diameter of this tool has been stored in the tool table previously, and will be modified by the machine operator if necessary at run time.

CW arc with cutter on the righthand side of the cutting path. Cutting path (not the center of the tool) begins at the current position and ends at the position specified in the next dimension command.

Radius of the workpiece surface to be 0.750".

#### TOOL DATA

Tools may be numbered in any order. Format will vary somewhat for some types of machines, but a typical format for a milling/drilling machine would look like this:

1 S150 L4.5 FZ40 D0.6705 FXY25 EN5

The part programmer has specified the following:

- Spindle speed 150 (RPM)
- Tool length 4.5000"
- Plunging feedrate 40 inches per minute
- Tool diameter .6705"
- Milling feedrate, roughing: 25 inches per minute
- Milling feedrate, finishing: 5 inches per minute.

#### PART REPORT FORMATS

##### HEADING

The heading is typed out on the supervisory Teletype at the time the part program is read into the computer. The first line of the report consists of up to sixty alphanumeric characters representing part number and other part and program identification data. The last four characters of programmer data show the number of memory cells needed to store the program preceded by the letter "N" so that only fifty-five characters may be entered at the head of the part program completely at the volition of the part programmer.

DEC-3701-68-768-R2-21N429

part identification, etc. entered by programmer	memory cells used
--	-------------------------

##### TROUBLE REPORT

Trouble reports are preceded and followed by an extra linefeed, to set them apart.

02:42|B14270|202700|00|W0.04,0.05,0.08|F0.52,0.60,0.80|72|

time	step where tool broke	tool no. and life	quan.	min., load	ave., time	max.	min., floor-to-floor time	ave., time	max.	% spindle utilization
------	--------------------------------	----------------------------	-------	---------------	---------------	------	---------------------------------	---------------	------	-----------------------------

##### SUMMARY REPORT

The other type of line on the report is the normal data format, called for either the supervisor's call button or by the machine operator giving the "job end" command.

18:36|S04.2|J02.6|00019|W0.04,0.05,0.07|F0.56,0.60,0.74|66|

time	set up	job time	quan.	min., load	ave., time	max.	min., floor-to-floor time	ave., time	max.	%
------	-----------	-------------	-------	---------------	---------------	------	---------------------------------	---------------	------	---



A typical application of DEC's new DNC system



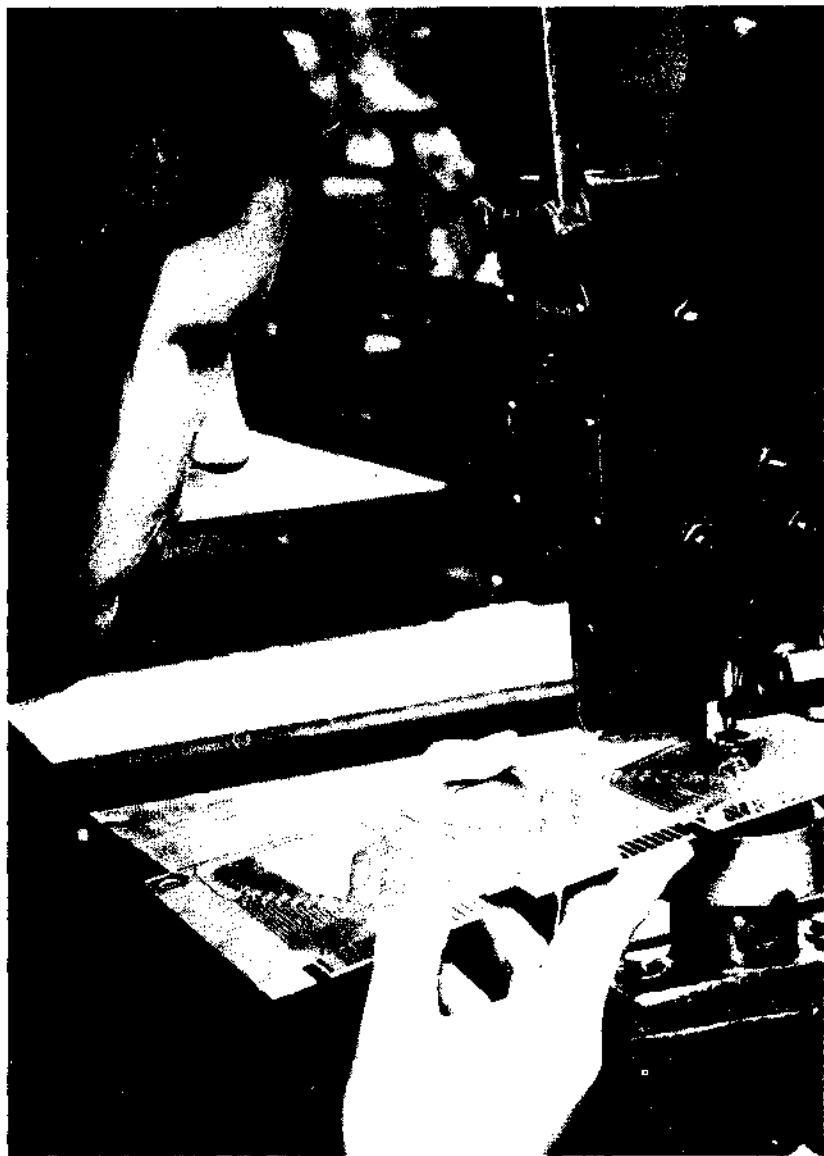

DEC's Module Assembly inserts rivets and eyelets into printed circuit boards before beginning component insertion production.

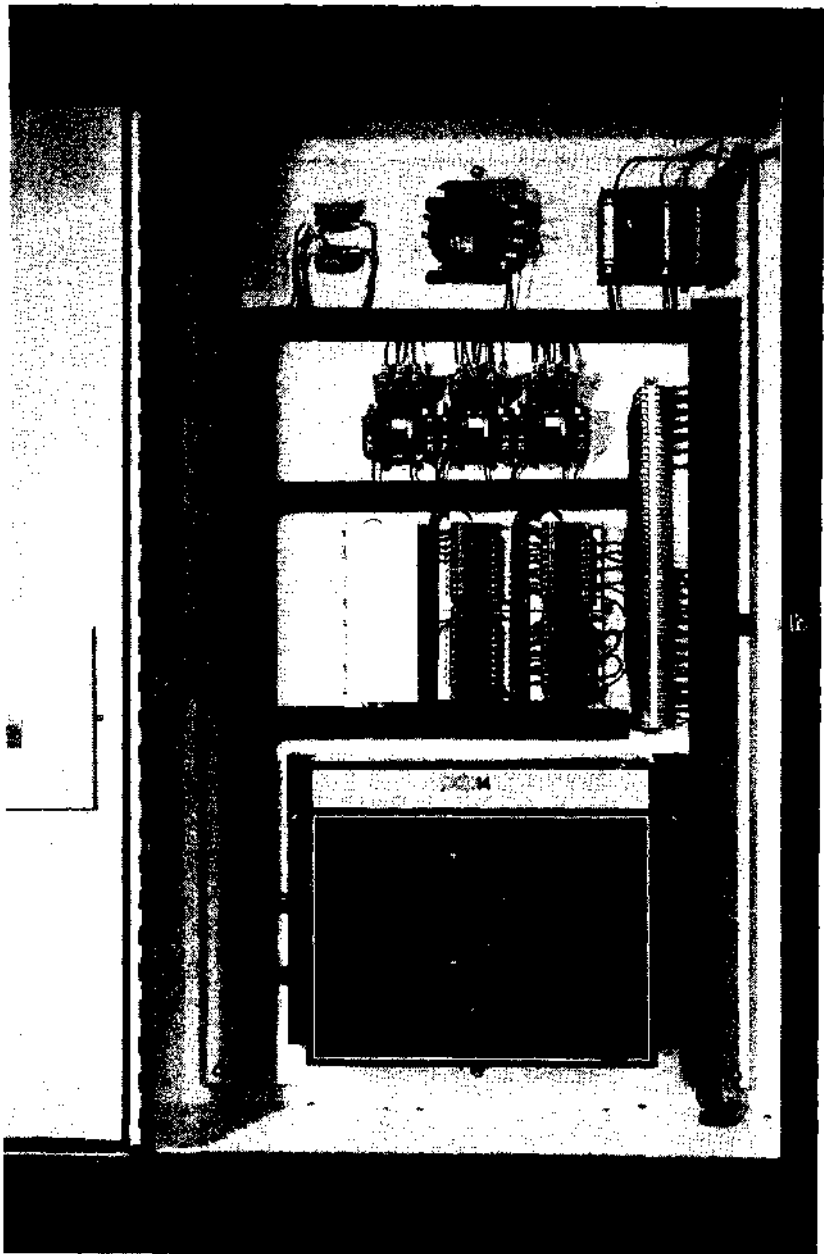

PDP-14 Solid State Industrial Control System (in NEMA enclosure)

## **PDP-14 AND PDP-14/L PROGRAMMABLE CONTROLLER**

**CONTROL  
PRODUCTS**

Digital Equipment Corporation's PDP-14 is a programmable solid state controller which is well suited to a variety of applications. The PDP-14 combines the advantages of solid state with the relay characteristics of simplicity and ease of use. It offers solid state logic in an easily programmed system which will operate in an industrial environment.

The basic PDP-14 Controller resembles a computer in that it contains input-output interfaces, a control unit and a memory. However, there are several important differences. First, the control unit is simplified and may be programmed using a few simple instructions. This allows a control engineer who has had no prior computer training to program the PDP-14. Second, the input-output interfaces are designed to accept 120 Vac line inputs, such as are field-wired from limit switches, and the outputs are similarly 120 Vac with sufficient capacity (500 Va) to drive solenoids or motor contactors. Third, the PDP-14 memory is nonvolatile; it is a hard-wired, read-only memory which contains the programmed instruction to control a specific application. Although the memory cannot be destroyed electrically, it can be altered by the insertion of a new set of wires.

The software and hardware of the PDP-14 offer a ready means of computer monitoring a control system. The PDP-14 serves as the AC interface to the controlled equipment. A computer interface between a PDP-14 and a PDP-8/i or 8/L general purpose computer is available. This computer interface permits the monitoring computer to interrogate inputs and outputs through the PDP-14 on a "cycle-stealing" basis. Using this technique, the monitoring computer may isolate component failure bringing downtime for repairs to a minimum. When necessary, the PDP-14 and the monitoring computer may communicate through 12 bit registers contained within the PDP-14. The monitoring computer may supply information to the PDP-14 which will affect its operation or it may supply actual instructions to be executed by the PDP-14.

The PDP-14 is designed to be more reliable, more flexible and, in most cases, less expensive than any other electrical system now available for control of machines and systems utilizing two state devices such as limit switches, pushbuttons, motor contactors and solenoids.

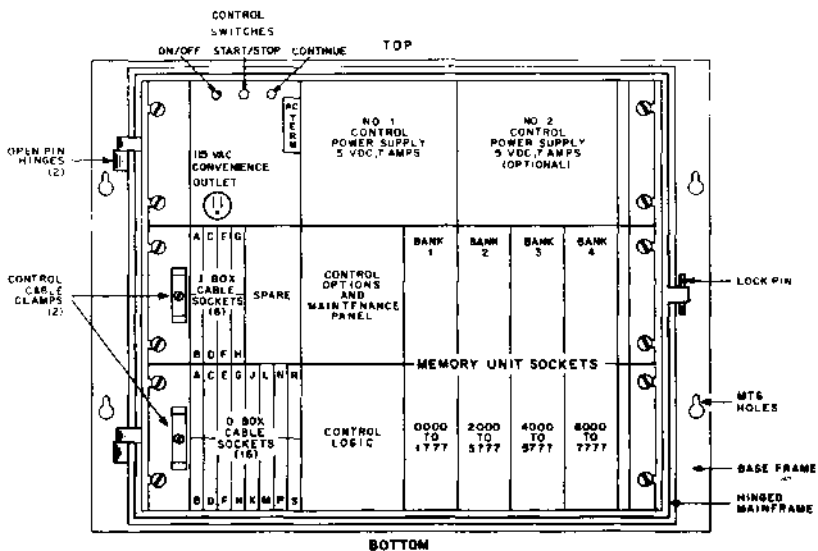
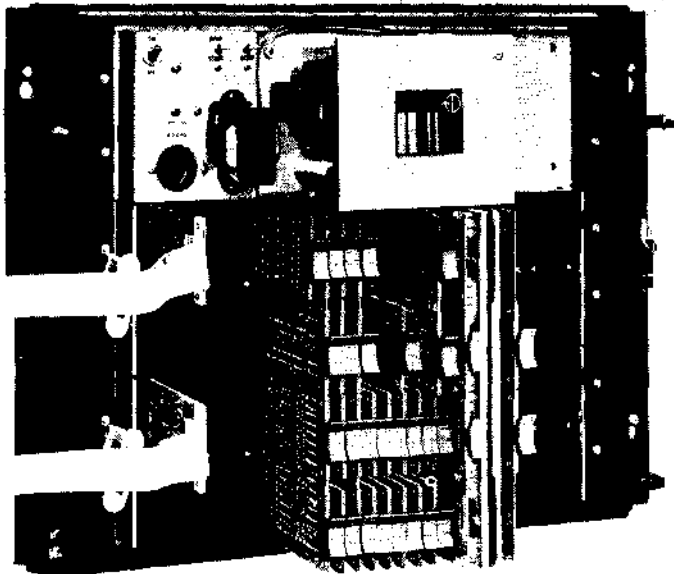

PDP-14 Mainframe

**The PDP-14 system is all solid-state, and inherently reliable because of two key factors.**

**a. The K Series industrial control modules.** For several years, the K Series has been widely accepted by industry as the most reliable solid-state module series available at reasonable cost. The rugged and flexible K Series has been designed into many types of custom control systems where speed and reliability are demanded. It is now available to serve the control needs of the mass-production industry as part of the PDP-14 system.

**b. DEC experience as leader of the small-computer field.** Switching circuits in a computer must function reliably hundreds of thousands of times a second. We have applied our knowledge of solid-state design and programming techniques to the PDP-14.

The PDP-14 system was designed specifically for industrial control. It is an integrated group of plug-in modular components. This allows the user to buy only the equipment actually needed for his control function. The modular approach also allows components to be easily replaced if necessary.

The "memory" used is a matrix of wires, inserted in the PDP-14 Control unit. This matrix is directly analogous to the wiring used in relay panels — but much smaller. It directs the entire operation of the PDP-14, and is designed by each user for his specific control needs, using a flexible computer program. This memory is so inexpensive that if changes in your manufacturing dictate new control operations, you can simply discard the memory and design a new one.

Large industrial relay control panels have a normal service life of two to five years, and then must be replaced entirely. During this period, individual relays and contacts must constantly be replaced. In contrast, the PDP-14 has no moving parts, and its components have a normal life expectancy of over ten years.

The PDP-14 system initial cost is about the same as relay systems, and for large control applications, is even less. In ten years of manufacturing, you could wear out three relay systems, and the PDP-14 should still be functioning reliably. Maintenance costs are reduced. And if the machinery is ever refitted for a new task, you don't have to start from scratch; just replace the PDP-14 memory.

As added bonuses, the PDP-14 system requires far less power and as little as one-tenth the space of conventional systems.

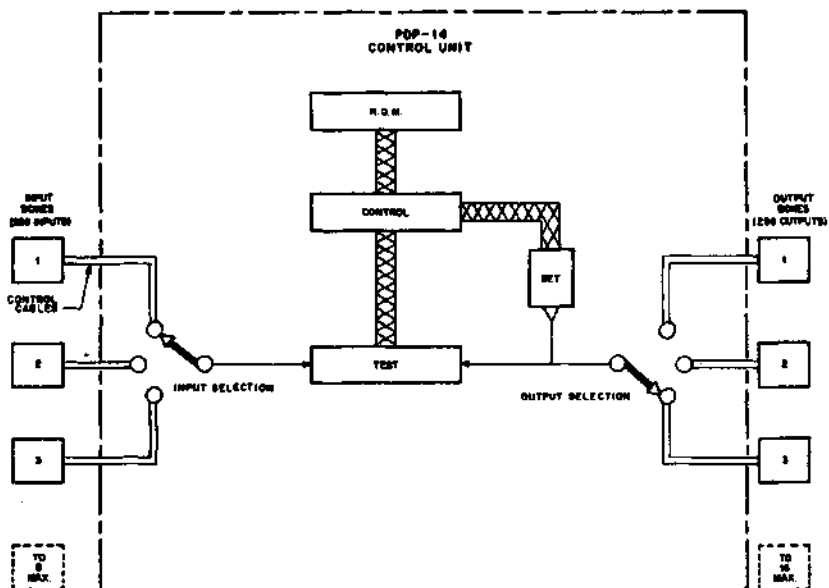

**PDP-14 System Diagram**

## PDP-14 System Components

The PDP-14 Control System is a unified assembly of three basic units:

- a. Input Interface Boxes ("I" Boxes)
- b. The PDP-14 Programmed Control unit
- c. Output Interface Boxes ("O" Boxes)

All system inputs and outputs are designed for 120 volts AC, 60 Hz, single-phase, compatible with the present industry standard.

### INPUT BOXES

The "I" boxes are signal-conditioning devices; they accept 120 VAC inputs from two-state sensing devices such as limit switches, push buttons, proximity switches, pressure switches, and photo-cells. These inputs are converted into signals which are proper for our solid-state equipment. They then pass along control cables to the PDP-14 Control unit. Each I-box contains 32 inputs. A maximum of eight I-boxes, providing a total of 256 inputs is permitted in one PDP-14 system.

Input boxes may be substituted for output boxes to expand the input capabilities (in increments of 32) to a maximum of 512 inputs.

### PDP-14 CONTROL UNIT

The control contains a wire matrix or "braid", which is the memory of the entire unit. It is called a "read-only memory," or "ROM" because it cannot be altered electrically (that is, "written on"). The ROM is actually a list of permanently wired electrical instructions which are "read" by the control to determine its operation.

The control operates in a way analogous to scanning a relay ladder diagram rung by rung. Each rung of the ladder represents a specific group of sensed input conditions which must be satisfied to cause a change in the condition of an output. The ROM contains instructions in small groups, each corresponding to a single rung in the ladder. The ROM directs the control to select each input specified in a group and test whether it is on or off. (This is the action performed by the "Test" unit shown.) Finally, the specified output is selected and set on or off, based on the test results. (This is the function of the "Set" blocks.) The control now continues to the next group of inputs and outputs, and repeats the process. This action proceeds one instruction at a time, but so fast that all inputs are checked and outputs properly changed in thousandths of a second; in fact, usually faster than one or two control relays could respond.

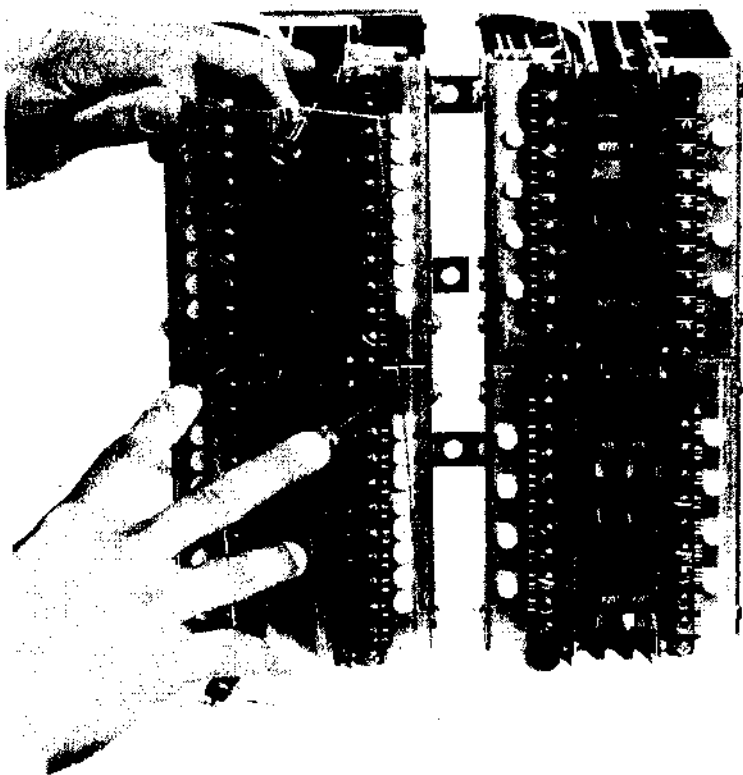

PDP-14 Input and Output Boxes



## **OUTPUT BOXES**

Control signals sent from the control are accepted by the "O" boxes to activate selected 120 VAC outputs. Each output is a triac, the solid-state equivalent of a remotely controlled switch. Once set on, each output remains on and supplying power until it is set off by a new control signal.

Output boxes have an additional system function; they can be interrogated by the control unit to determine whether their outputs are on or off. In this mode, they can be considered as control inputs.

Each output of an output box can be connected to its own source voltage and to loads, such as solenoids, motor contactors, small motors, lamps and signalling devices.

Each output box contains 16 outputs. A total of 16 O-boxes providing 256 outputs may be incorporated in one PDP-14 system.

## **READ-ONLY MEMORY**

The heart of the control operation is the read-only memory (ROM). The ROM contains all the instructions which allow the Control to sample specific groups of inputs and then select a specified output and turn it on or off. The ROM is provided in one to four separate plug-in sections, each of which has over 1,000 "locations" in which control instructions are stored. The number of sections required is determined by the size of the control "problem" — the number of inputs and outputs, and the number of control decisions which must be made.

The ROM is an actual physical matrix or "braid" of solid wires permanently embedded in a potting compound and surrounded by electronic sampling circuits (96 transformer cores) in a "sandwich" packaging. The arrangement of the braid wires is determined in a series of computer-aided steps, which result in a punched paper tape. This tape is used to operate an automatic wire placing machine, or "loom," which forms a wire braid. This braid, returned to be installed in the Control unit, represents the specific solution to the individual control problem. Whenever this element is changed, the PDP-14 System behaves as though it were rewired, allowing you complete flexibility in changing machine operations and retrofit.

In operation, the ROM acts like a series of wires strung through and around small current transformers. Each wire represents eight individual control instructions, which are read by sending a current pulse through it. The read out is in groups of eight instructions. The single desired instruction is selected from these eight. Only the transformers with wires running through their cores will be energized. The pattern of energized transformers is then read as an electronic instruction code. The code is the 12-bit binary instructions which are understood by the PDP-14 control unit.

It is possible to change as many as 20 wires (approx. 15%) of the ROM by cutting out wires and manually replacing them with new ones.

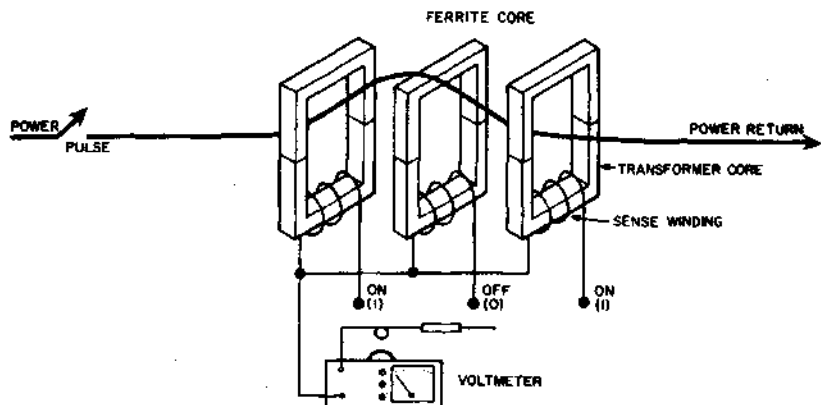

Schematic Of Three PDP-14 ROM Transformer Cores

## ACCESSORIES

In addition to normal outputs, the PDP-14 system may be equipped with solid state timers, retentive memories, and storage outputs. The timers and retentive memories are provided in an accessories box (A-box). The storage outputs are provided in a storage module consisting of 16 storage outputs.

The solid state timers may be adjusted to provide timing functions from fractions of a second to thirty seconds. The retentive memories are mercury-wetted relays which provide 1-bit of storage information after a power failure. The storage outputs provide temporary storage of intermediate processing results, status information, and are sometimes used for communication between the PDP-14 and the monitoring computer.

Also supplied as an accessory is an auxiliary power supply which is required for large PDP-14 systems.

## PROGRAMMING THE PDP-14

Programming in the PDP-14 system is simply the procedure used to generate the read-only memory (ROM) to control a process or machine. PDP-14 programming does not require previous computer experience; it does require experience in machine control.

PDP-14 programs provide relationships between inputs (limit switches, push buttons, selector switches, etc.) and outputs (solenoids, motor contactors, indicator lights, etc.). These relationships, or control functions, may be expressed as Boolean equations which, when solved for particular input values, specify the state (ON or OFF) of an output.

Machine inputs and outputs must be assigned to the PDP-14 input (I) and output (O) boxes before a PDP-14 control program can be written. These assignments permit the PDP-14 instructions to test the state of specific inputs and outputs. Once these assignments are made, the inputs and outputs are referred to by unique numbers preceded by an "X" for an input, or a "Y" for an output. For programming purposes, these X and Y numbers represent specific input and output devices.

### BOOLEAN REPRESENTATIONS OF MACHINE CONTROL

Programming a PDP-14 requires familiarity with simple Boolean representations of control functions. These representations are comprised of "operators" and "variables". The variables of PDP-14 control equations are inputs (X's) and outputs (Y's). The variables have two "states", namely, ON and OFF. The operators in these equations are \* (AND), + (OR) and / (NOT). Parentheses may be used within equations to group variables.

For example, the equation:

$$Y_{10} = X_{23} + X_{21} * Y_7$$

is read "output 10 is set ON when input 23 is ON, or when both output 7 and input 21 are ON." This equation instructs the PDP-14 to test input 23; if it is ON, set output 10 ON. In input 23 is OFF, test output 7 and input 21; if they are both ON, set output 10 ON. If neither set of conditions is satisfied, set output 10 OFF.

The above equation could be represented by the following familiar ladder diagram:

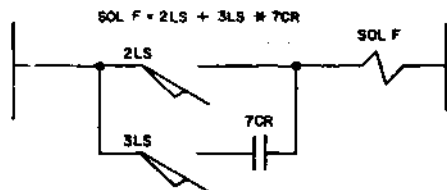

where SOL F corresponds to  $Y_{10}$ ; 2LS corresponds to  $X_{23}$ ; 7CR corresponds to  $Y_7$ ; and 3LS corresponds to  $X_{21}$ .

A set of control functions similar to the preceding example comprise a PDP-14 program. A series of equations corresponding to these functions and written in terms of X's and Y's are then translated into the PDP-14 machine code program using BOOL-14.

#### BOOL-14

BOOL-14 is a translator program for control equations. It operates on a PDP-8 family computer and translates the equations into the PDP-14 machine code instructions needed to solve these equations. The machine code instructions will later be woven to form the ROM for the PDP-14. Before this happens however, the program should be rigorously tested and debugged. This is done with SIM-14. The translation for two equations is:

$$Y10 = X23 + X21 * Y7$$

```
0000 2423 TXN 023
0001 5407 JFN 007
0002 2021 TXF 021
0003 1007 TYF 007
0004 5007 JFF 007
0005 3010 SYF 010
0006 0344 SKP
0007 3410 SYN 010
```

$$Y17 = X2 + X51 + X3 * Y7 + X4 * Y21$$

```
0010 2402 TXN 002
0011 2451 TXN 051
0012 5423 JFN 023
0013 2003 TXF 003
0014 1007 TYF 007
0015 5023 JFF 023
0016 2004 TXF 004
0017 1021 TYF 021
0020 5023 JFF 023
0021 3017 SYF 017
0022 0344 SKP
0023 3417 SYN 017
```

The resultant PDP-14 program is a "closed loop" of disjoint instructions groups. Each group of instructions solves an equation for one output, setting it on or off. For example, if a machine control requires twenty outputs, there are twenty equations and instruction groups in the control program. The last instruction group is terminated with a "jump" to the first instruction group. The following diagram illustrates the construction of the program.

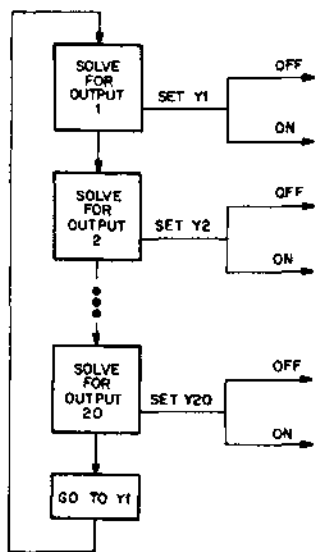

## SIM-14

SIM-14 is a PDP-8 based program which simulates PDP-14 operation in two modes. The user may operate in an offline or "local" mode to debug or modify his program completely within the PDP-8. When relatively certain that the program is correct, the user may switch to on-line mode where the program is executed to control the machine's operation.

Local mode debugging offers three features for testing programs.

1. The user supplies input states for a given equation and SIM-14 reports the resultant state of the output. This proceeds equation by equation.
2. The user generates a complete truth table, or binary array, which completely defines the state of an output for all possible input states. This is also done for each equation.
3. The user tests the complete program using simulated execution. He tests the complete program in sequence by specifying input states. Changing output states are reported by SIM-14. The user continues to vary input values to test all segments of the program.

The following are sample truth tables as generated by SIM-14 for the two equations which were translated by BOOL-14.

$$Y10 = X23 + X21 * Y7$$

.TA10  
.X23  
.X21  
.Y7  
.S0

A X023  
B X021  
C Y007

ABC  
000=0  
001=0  
010=0  
011=1  
100=1  
101=1  
110=1  
111=1

A X002	100000=1
B X051	100001=1
C X003	100010=1
D Y007	100011=1
E X004	100100=1
F Y021	100101=1
	100110=1
ABCDEF	100111=1
000000=0	101000=1
000001=0	101001=1
000010=0	101010=1
000011=1	101011=1
000100=0	101100=1
000101=0	101101=1
000110=0	101110=1
000111=1	101111=1
001000=0	110000=1
001001=0	110001=1
001010=0	110010=1
001011=1	110011=1
001100=1	110100=1
001101=1	110101=1
001110=1	110110=1
001111=1	110111=1
010000=1	111000=1
010001=1	111001=1
010010=1	111010=1
010011=1	111011=1
010100=1	111100=1
010101=1	111101=1
010110=1	111110=1
010111=1	111111=1
011000=1	
011001=1	
011010=1	
011011=1	
011100=1	
011101=1	
011110=1	
011111=1	

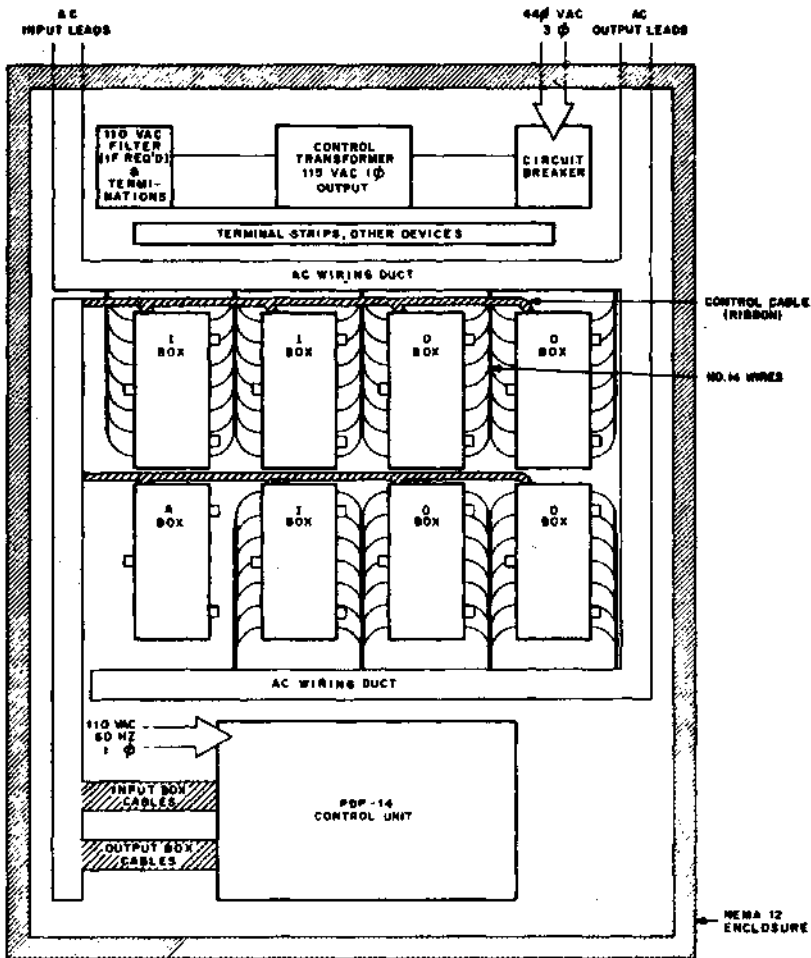

PDP-14 System Layout Example



## PDP-14 SYSTEM EXAMPLE

What are the procedures involved in designing and maintaining a PDP-14 system?

- Configuring the system and selecting hardware
- Developing the control program
- Installing the hardware
- Debugging the system
- Installing the ROM
- Maintaining the system

All except the first of the above steps are assisted by software provided by DEC.

### Configuring the System

How do you decide what PDP-14 hardware you will need to solve your control program? You must answer the following questions.

1. How many real outputs (motor contactors, solenoids, lights, etc.) are required?
2. How many timers are needed?
3. Must the PDP-14 record information with storage outputs or retentive memories?
4. How many inputs (limit switches, push buttons, selector switches, pressure switches, etc.) are in the system?
5. Will the PDP-14 be monitored by an external computer?
6. How many variables are in an equation to control a typical output?

Question 1 determines the number of output boxes required. Let's assume there are 72 outputs. (If a relay system is being changed over to PDP-14, control relays should be excluded from this count.) These 72 Outputs require 5 output boxes and leaves 8 spare outputs.

Question 2 concerns the selection of accessory boxes. An "A-box" can contain 16 timers. Let's assume there are 12 operations which must be timed. You need one A-box and 6 timer cards (each provides 2 timers).

Question 3 also concerns the A-box, if retentive memories are needed. Retentive memories are available as one mercury-wetted relay per card. Only 4 retentive memories may be used in one A-box, and each uses two output slots. Let's assume no retentive memories are needed. However, there are 7 status conditions which must be recorded (similar to the old control relay), and 5 push buttons, the activation of which the PDP-14 must remember after the input is no longer present. These require 12 storage outputs or one storage module with 4 spares.

Question 4 is a straight forward count of two state inputs. Each position of a selector switch is considered as a single input. Let's assume there are 91 inputs. Thus 3 input boxes are required, providing 96 input slots, five of which are spares.

Question 5 has several implications. The obvious need is a computer interface. However if the PDP-14 is to be monitored, several other considerations are also needed. Storage outputs may be required for communication between the PDP-14 and the monitor. More memory may be needed to handle monitoring information. Let's assume that the monitor will simply check inputs and outputs on a cycle-stealing basis and that there will be 5 status words sent from the PDP-14 to the monitor. The requirement is for approximately 25 extra PDP-14 locations.

Question 6 is probably the toughest to answer. It is aimed at an estimate of the amount of PDP-14 memory required for the system. If equations on the average contain 5 variables (e.g.  $Y1 = (X2 + X3 + X4) * X5$ ), or more, a good estimate is that it will require 2N PDP-14 memory locations to solve the equation, where N is the number of variables. For less than 5 variables,  $2N + 2$  is the suggested estimating rule.

Let us assume there are on the average 7 variables in an equation ( $N = 7$ ). We have 72 output equations, 12 timer equations, 12 storage output equations, a total of 96 equations each requiring approximately 14 PDP-14 (2N) locations. Thus, the memory requirement is 1344 locations ( $96 \times 14$ ). We also needed 25 locations to handle the monitoring needs. Thus a 2K (2000 location) memory is needed.

There are several trade-offs which may be made when configuring a system. Unused outputs may be used as storage outputs; programming (subroutines) may replace other storage outputs; monitoring systems may adjust the amount of processing done in the PDP-14 with the amount done in the monitor to vary the amount of memory required; excess memory may be used to diagnose equipment failures by turning on signal lights when inputs are found to be in the wrong state.

#### **Developing the Control Program**

The PDP-8 computer is used to run BOOL-14 and SIM-14 to write the PDP-14 control program. If the PDP-14 program will require greater than 1K of memory (1000 locations), an 8K PDP-8 is needed to develop the program. For programs of 1K or less, a 4K PDP-8 is sufficient.

The steps involved are:

1. Assign each input and output to a specific PDP-14 I or O-box and obtain the X and Y number.
2. Write the Boolean equations for each output using the X and Y numbers for inputs and outputs.
3. Type the equations on the Teletype.
4. Use BOOL-14 to generate the machine code program.
5. Read the machine code program into SIM-14.
6. Use local mode of SIM-14 to verify the instructions for each equation, by varying the input and recording the resultant output value; generate

truth tables for each equation; use simulated execution to test the whole program without attaching the PDP-14. SIM-14 will later be used to debug the complete hardware/software system.

### **Installing the PDP-14 Hardware**

The PDP-14 hardware is installed within a standard NEMA 12 enclosure. The PDP-14 control unit is mounted near the bottom of the enclosure with the cables connecting it to the input, output, accessory and storage boxes. These boxes are usually mounted above the PDP-14 but still within the NEMA enclosure.

The required 110 VAC power is supplied to the processor directly. The I and O-boxes must be supplied independently with 110 VAC at each terminal either from an input, (e.g. limit switch) or to be switched to an output (e.g. a solenoid). The field wiring to the input and output boxes may be direct or via terminal strips within the NEMA 12.

The PDP-14 system when installed may be thoroughly checked to ascertain that no damage to the circuitry was received during shipment using TEST-14, a PDP-8 based diagnostic program. This program operates on a 4K PDP-8 and exercises all of the internal PDP-14 logic and contains options for testing the I and O-boxes. Failures cause message typeouts on the teletype console indicating which test the PDP-14 failed. The documentation provided indicates which module or modules may be defective, and the priority in which they should be checked. A defective module may be replaced in seconds.

If the I and O-box circuitry is to be tested, the field wires to the O-boxes should not be connected. Field wiring to inputs which directly turn on other devices should also be disconnected.

Once the PDP-14 has been thoroughly tested (one pass through the test takes approximately 3 minutes), the field wiring, if not already in place, is completed to the I and O-boxes and the complete system is debugged.

### **Debugging the System**

When the program has been written and debugged and the hardware is installed, the system is debugged using online mode of SIM-14. In online mode, the PDP-14 program, which has been thoroughly debugged in local mode of SIM-14, is supplied to the PDP-14 and executed. The machinery will operate under SIM-14 as it will when the ROM is installed except that the PDP-14 will check inputs and set outputs at a significantly faster rate when its program is stored in the ROM. (This difference in processing speed between online mode and the ROM will not be a factor in most applications and can be counteracted, if necessary, through use of software subroutines.)

Bringing up a system that is to be controlled by a PDP-14 is considerably easier than a relay controlled system, because of the features of online mode and the terminal lights of the I and O-boxes. Wiring errors are easily detected by looking at indicator lights. If an operation does not occur, a glance at the lights indicates which input or inputs is not present. Using SIM-14, the state of storage outputs, timers, and retentive memories may be determined. Quick patches may be made to the program if problems are discovered. Check out progresses at a considerably improved pace because of the PDP-14 hardware and software.

The PDP-14 program may be executed in online mode in sections, using strategically placed "program stops" at which point execution of the PDP-14 program halts and control returns to SIM-14. Shut-down sequences or "stop equations" that are executed before control returns to SIM-14 may also be used in online mode. Thus the PDP-14 program may be run in total, or if desired, in parts thereby testing each individual programmed operation.

### **Installing the ROM**

Once the system has been checked-out and the program is correct, a paper tape is punched from which DEC will weave a ROM. The ROM will be returned to you in two to three weeks. During that time the PDP-14 may continue to operate in online mode of SIM-14 and thus the controlled equipment may still be operated.

Once the ROM (or ROM's, if a greater than 1K program is used) has returned, it is plugged into the PDP-14 mainframe. The PDP-8 interface cables for SIM-14 online mode are removed, and the PDP-14 system is complete.

Field rewiring can change any instruction in the program after it is woven in the ROM. The procedure is simply to clip the lead from the old wire, and solder a new wire in its place. The new wire is then placed through, or around, the series of transformer cores to represent the correct instructions. If more than 15% of the programmed instructions must be altered, the rewiring may become cumbersome and a completely rewoven ROM should be considered.

A PDP-8 based program, VER-14 may be used to verify that the memory contains the same instructions as contained on a paper tape. Thus a program change should be made using SIM-14 and a new tape generated. (The change should, of course, be tested in local and online modes of SIM-14 first.) The wires may then be replaced in the ROM. When the ROM is re-installed in the PDP-14, VER-14 may be used to verify that the changes were properly made.

### **Maintaining the System**

Once a system has been installed it may be maintained in several ways. When a failure occurs, it must be diagnosed to be in one of three areas:

- (1) the controlled machine
- (2) the input, output accessory boxes or The Storage Module
- (3) the PDP-14 control unit

Assume that the failure may be characterized as, "this should happen now, but it doesn't!" Examining the input and output lights, it can easily be determined if the output to start the operation is present and if the inputs required to activate this output are present. If the output is on, the problem is in the machine; if the output is off and an input required for that output is missing, the problem is in the machine. If all inputs are present and the output is missing, the fault can be either in the PDP-14 I and O-boxes or in the PDP-14 control unit.

Once it has been determined that the failure is in the PDP-14 part of the system, the isolation of the failure to either the I and O-boxes or the PDP-14 processor itself is achieved by assuming that the I or O-box is at fault. The I and O-boxes may be checked out by swapping the modules concerned with the faulty input or output. Spare part kits are available for this purpose. If

module swapping in the interface boxes does not resolve the problem, the PDP-14 processor must be considered at fault.

The processor may be checked out with TEST-14, the PDP-8 based diagnostic program to ascertain that the PDP-14 circuitry operates properly. If TEST-14 does not point out any electronic failure, the ROM memory may be tested with VER-14 against the paper tape record of the program. If no problem has been discovered in either the memory or the processor, it must be in the circuitry of the I and O-boxes. These may be tested using TEST-14 and a special box tester fixture. To perform this test, the field wires are first removed from the O-boxes.

If a PDP-8 is not available for testing the PDP-14, the central processor may be maintained by using the detailed maintenance manuals supplied with the PDP-14, or by module swapping using the spare parts kit which can be purchased separately.

The maintenance procedure described above may be performed by the end user or by the wide network of well trained DEC Field Service Specialists. Service contracts beyond the normal warranty for the PDP-14 are available.

### **PDP-14/L**

The PDP-14/L has all the features and advantages of the PDP-14 but is a smaller version, limited in expandability. The PDP-14/L can be expanded only to 64 inputs and 64 outputs (or 128 inputs only). Memory expansion is limited to 1,024 words. The 14/L is programmed in the same manner as the PDP-14 with identical software and diagnostics. In fact, they are so similar that their control units are interchangeable.

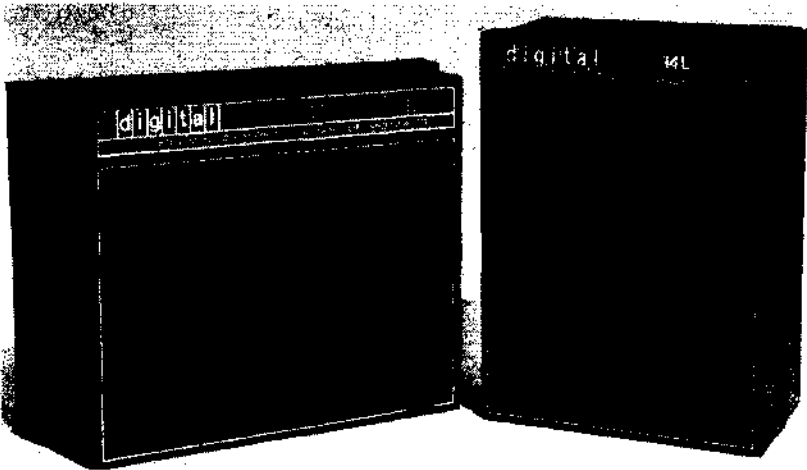

## CONTROL SYSTEMS

## CONTROL PRODUCTS

The Control Systems Group of Digital Equipment Corporation offers to its customers a complete design and manufacturing service in the area of module systems and PDP-14 special systems. The Control Systems Group maintains a qualified staff of experienced design engineers together with their manufacturing counterparts to provide these services with a high level of technical competence and at a reasonable cost saving to the customer.

In order to clarify and establish the policies and services offered by each of the two divisions of Control Systems: Modules Systems and PDP-14 Special Systems will be defined separately.

### A. Module Systems

Digital Equipment Corporation offers to its customers the capability of designing and building special purpose digital logic systems. The ultimate aim of this group is to establish a limited production quick turn around capability.

To make this feasible, a minimum initial order of ten identical units must be ordered. After the initial commitments, orders for single units will be accepted. It should be understood that this group can take an existing system and produce it without going through the prototype stage. However, if there is any question concerning the operation of the system, a prototype will be required.

With respect to the prototype, prior to acceptance of the purchase order, all specifications must be defined and agreed upon between the Control Systems Group and the customer. All testing of the unit will be performed to this set of specifications. Acceptance will be based upon a successful demonstration to the customer that the specifications have been met. Digital Equipment Corporation will not warrant the system beyond the date of acceptance but will honor all existing module warranties.

The engineering and technician labor which a customer pays for at this time should be considered as his investment in product development and as such must be written off over the expected life of the product. The customer's decision at this point must be to decide how many systems are necessary to economically cover his investment.

Digital Equipment Corporation will, in effect, act as consultant engineers to these customers and the charges which are assessed must be viewed in this light. Unlike consultants, however, a maximum charge for engineering is specified which limits the amount which will be charged for these services.

The Control Systems Group also provides full documentation (engineering prints, module layouts, and, if deemed necessary, an operational write-up of the system). Should the need arise for training of the customer's personnel in the operation of the equipment, the Control Systems Group will also provide this service.

## **B. PDP-14 Special Systems**

The primary function of the PDP-14 Special Systems group is to offer to the customer Digital Equipment Corporation's experience and talent in designing tailor made control systems based upon a PDP-14 central processor. In order to accomplish this, each system will be developed by working as closely with the customer as possible. An emphasis will be placed on utilizing as many PDP-14 standard options as possible and specialized designs will be kept to a minimum. In addition, the PDP-14 Special Systems Group can provide computer based PDP-14 systems as well as stand alone PDP-14 systems. This approach offers the lowest possible cost and speediest delivery.

When it is determined that all of the customer's requirements have been decided, a system will be designed implementing these functions. At that time, a firm quote will be developed to cover the cost of the equipment. In addition to the hardware, the quote will cover labor, documentation, diagnostic programming and testing costs. Each system will be warranted to meet all of the electric specifications as agreed upon between the customer and Digital Equipment Corporation.

Acceptance testing will be performed at Digital Equipment Corporation and the customer will be notified sufficiently in advance should he care to be present at the time of the test. The warrantee of the system will be identical to that of the PDP-14 upon which it is installed.

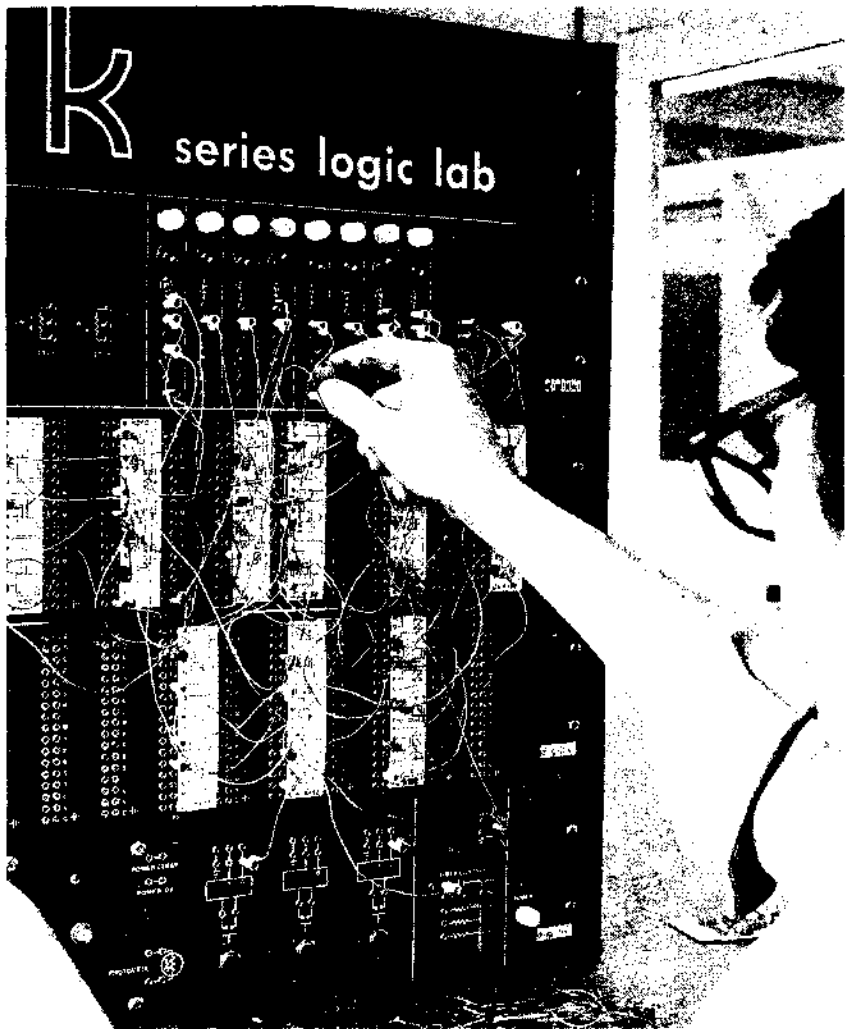



## **K-SERIES LOGIC LAB**

### **INTRODUCTION**

The K Series Logic Laboratory is designed for use with K Series Modules. It is a device for building prototype systems for experimentation and proof of logic design as well as an effective tool for learning solid state control logic.

It is excellent for training users in digital logic techniques by enabling an individual to construct logical networks, with a "hands on approach" to learning control systems for Industrial Applications.

The K Series Logic Lab is a completely self contained system consisting of a power supply, photo cell, pulse generator, switch controls, indicators, mounting hardware and a recommended basic complement of logic modules necessary to construct a working system. The system is expandable and can accommodate additional K901 patchboard panels for mounting additional logic modules.

### **EDUCATION AND TRAINING**

As a training device the K Series Logic Lab offers the engineer, technician, and user a step by step approach to building an understanding of various digital logic functions, such as, AND, OR and the operations of NAND and NOR etc. The user has the option of using NEMA or MIL spec symbology when making logic connections. Symbology cards on basic logic modules for use with the K901 patchboard panel are printed with NEMA on one side and MIL SPEC 806 on the reverse side.

### **BREADBOARDING AND TESTING**

The logic laboratory power supply is capable of supplying 5V-DC for about 100 modules. There is no restriction on the size of a system which can be implemented, since additional patchboard panels can be ordered and "K" Logic Laboratories interconnected directly.

There is no substitute for actually building the system and verifying the logic.

Some common uses of the Logic Laboratory are listed below. Many of these are described in detail in the Control Handbook and part III in the 1969 Positive Edition Logic Handbook:

Timer Sequencers	Serial Adder
Shifter Sequencers	Stepping Motors Control
Parallel Counters	Pulse Generator
Pulse Rate Multiplier	Annunciator

# CONTROL PANEL — POWER SUPPLY

K900

**K**  
SERIES

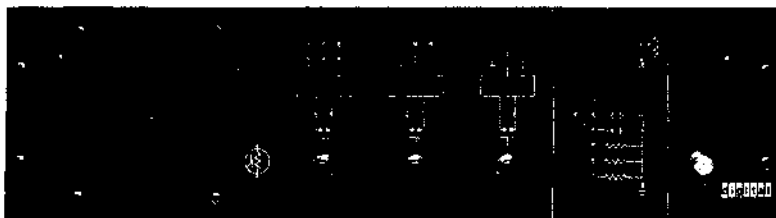

The K900 is a combination power supply and input control panel. The input devices include a photocell, three push button pulsers and timing components for a K303 clock mounted in a K901 panel. Clock timing components are provided for frequency steps in ranges of 2Hz to 60Hz and 200Hz to 6K Hz. Wiring diagrams for properly connecting the clock are shown in the logic and control handbooks (reference K303). The power supply can drive approximately ten type K901 panels of K series FLIP CHIP® logic. Pulsers consist of a K501 schmitt trigger with a K581 switch filter. Power is supplied by K731, K743 and K732 power supply modules.

### Electrical Characteristics

Input voltage: Power supply: 115V 50-60 cps  
Output voltage: +5 VDC  $\pm 10\%$   
Output current: 3 amp

### Mechanical Characteristics

Panel width: 19"  
Panel height: 5 $\frac{3}{8}$ "  
Depth: 12"  
Finish: black  
Power Unit connection: 18/3 AC power cord

Power Output connection: Hayman Tab terminals which fit AMP "Faston" receptacle series 250, part 41774 or Type 914 Power Jumpers.

**K900—\$185**

**PATCH BOARD PANEL**  
K901, 911

**K**  
**SERIES**



**K901 PATCHCORD MOUNTING PANEL**

This panel provides up to ten FLIP CHIP® modules with power and patch connections. Space between patching sockets allows insertion of logic diagrams. Logic diagrams are printed on all FLIP CHIP® Module data sheets. More permanent plastic diagrams are available for those modules listed.

PANEL WIDTH 19 in.

PANEL HEIGHT: 5 $\frac{3}{8}$  in.

DEPTH: 6 $\frac{1}{2}$  in. with FLIP CHIP modules inserted

FINISH: Black

POWER INPUT CONNECTIONS: Tabs which fit AMP "Faston" receptacle series 250, part 41774.

**911 PATCHCORDS**

DEC Type 911 Banana-Jack Patchcords are supplied in color-coded lengths of 2 in. (brown), 4 in. (red), 8 in. (orange), 16 in. (yellow), 32 in. (green), and 64 in. (blue). Patchcords may be stacked to permit multiple connections at any circuit point on the graphic panels of the DEC K901 Mounting Panel. The cords are supplied in snap-lid plastic boxes of ten for handy storage.

---

H901—\$125

911—\$9/pkg. of 10

---

**INDICATOR SWITCH PANEL  
K902**

**K  
SERIES**

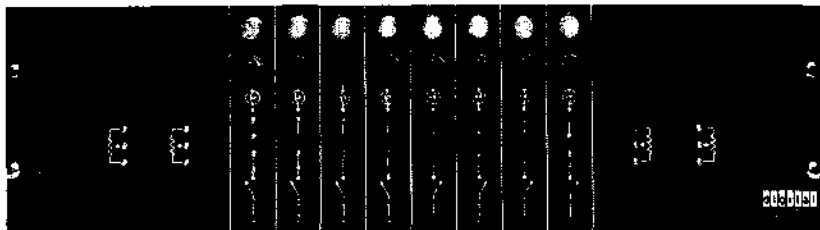

The K902 Panel provides facilities for control and observation of the Logic Laboratory. It contains eight indicator lights and a lamp driver module, eight toggle switches and four potentiometers. Connections to these devices are made with Type 911 Stacking Banana-Jack Patchcords.

**INDICATORS:** Indicators inputs accepts signals of +5V and ground. An open circuit input will light the indicator. If the input is returned to ground, the indicator will not light. The load is 1 ma.

**TOGGLE SWITCHES:** The toggle switches are single pole, single throw with a logic diagram to show the open and closed positions.

**POTENTIOMETERS:** The potentiometers are 250,000 ohms. They may be used to control the frequency of delay one-shots or clock circuits in the K901 Mounting Panel.

**MECHANICAL CHARACTERISTICS**

**PANEL WIDTH:** 19 in.

**PANEL HEIGHT:**  $5\frac{3}{8}$  in.

**DEPTH:**  $6\frac{1}{2}$  in.

**FINISH:** Black

**POWER INPUT CONNECTIONS:** Tabs which fit AMP "Faston" receptacle series 250, part 41774.

**K902—\$145**

**PATCH PANEL BOARD  
K903**

**K  
SERIES**

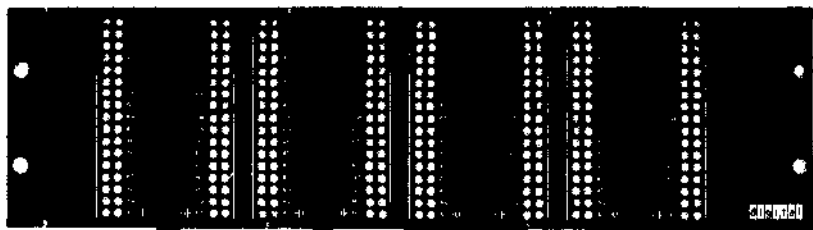

This patch panel provides logic power and patch connections for four double-height or eight single height FLIP-CHIP<sup>®</sup> modules. The panel was designed particularly for K Series double height modules including the interfacing modules (K5xx and K6xx). Two K903 panels cannot however be mounted together on a mounting rack due to socket overhang at the bottom of each K903 panel. Space between patching sockets allows insertion of logic diagrams. Logic diagrams are printed on all FLIP-CHIP<sup>®</sup> module data sheets. More permanent plastic diagrams are available for those modules listed.

PANEL WIDTH: 19 in.

PANEL HEIGHT:  $5\frac{3}{8}$  in.

DEPTH:  $6\frac{1}{2}$  in. with FLIP-CHIP<sup>®</sup> modules inserted.

FINISH: Black

POWER INPUT CONNECTIONS: Tabs which fit  
AMP "Faston" receptacle series 250, part 41774

---

K903—\$155

---

## MISCELLANEOUS ACCESSORIES

4913, 914

## HARDWARE

### 4913 MOUNTING RACK

The 4913 Mounting Rack provides support for a and up to four K901 Patchcord Mounting Panels, for a total of up to 40 FLIP CHIP® modules ready to be patched together for experiments. It may also be used to mount general purpose mounting panels such as the K943. The power supply must be mounted at the bottom for stability.

Height: 26¼ in.

Threads for mounting panels: 10-32

### 914 POWER JUMPERS

For interconnections between power supplies, mounting panels, and logic lab panels, these jumpers use AMP "Faston" receptacles series 250. Specify 914-7 for interconnecting adjacent mounting panels, or 914-19 for other runs of up to 19 inches. 914-7 contains 10 jumpers; 914-19 contains 5.

---

4913K	—\$25
914-7	—\$ 4
914-19	—\$ 4

---

**BASIC EQUIPMENT LISTS****BASIC LOGIC LABORATORY**

1-K901	Patchboard panel	125.00
1-K902	Indicator Switch Panel (complete with K683 module)	145.00
1-K900	Power Supply and Control Panel (complete with Power modules)	185.00
1 pair—4913	Mounting Rack	25.00

**RECOMMENDED LOGIC MODULES AND PATCHCORDS  
FOR USE WITH THE LOGIC LABORATORY**

	UNIT PRICE	TOTAL PRICE
4-K003	Expander	5.00
2-K012	Expander	8.00
3-K113	Gate	11.00
3-K123	Gate	12.00
2-K134	Inverter	13.00
1-K161	Decoder	25.00
1-K174	Comparator	24.00
1-K184	Rate Multiplier	25.00
2-K202	Flip-flop	27.00
1-K206	Flip-flop	20.00
2-K210	Counter	27.00
1-K220	Up-down Counter	55.00
1-K230	Shift Register	40.00
1-K303	Timer	27.00
1-K323	One shot delay	35.00
1-K376*	Timer Control (0.1-3.0 sec)	15.00
1-K378*	Timer Control (1.0-30 sec)	15.00
1-K373*	Timer Control (20 Hz-600 Hz clock)	11.00
1-K522	Sensor Converter	25.00
4 pks. of 10 patchcords (911-2")	9.00	36.00
5 pks. of 10 patchcords (911-4")	9.00	45.00
2 pks. of 10 patchcords (911-16")	9.00	9.00
1 pkg. of 10 patchcords (911-16")	9.00	9.00
26 symbology cards	.25 ea.	6.50

Complete K-Series logic lab with workbook  
and modules listed — H510

\$995.00\*

Asterisk\* denotes symbology cards unavailable. Symbology cards for use with K901 patchboard panel, .25 ea., minimum purchase of \$5.00 applies.

**IF ADDITIONAL K901 PATCHBOARDS ARE ORDERED:**

1-911-4"	pkg. of 10 patchcords	9.00
1-911-8"	pkg. of 10 patchcords	9.00
1-911-16"	pkg. of 10 patchcords	9.00
1-911-32"	pkg. of 10 patchcords	9.00

## K-SERIES INTERFACE MODULES

Recommended logic modules for input/output functions.

### AC Input/Output

1-K578	120 VAC Input converter	80.00
1-K614	120 VAC Isolated AC switch	88.00

### DC Input/Output

1-K580	Dry Contact Filter	28.00
--------	--------------------	-------

Listed below are a number of DC output drivers that may be used:

1-K644	DC output Driver	66.00
	or	
1-K656	DC output Driver	80.00
	or	

1-K658	DC output Driver	128.00
--------	------------------	--------

Each additional K series workbook	5.00
-----------------------------------	------

Note: only 3 out of 4 circuits are available when using above 3 modules with the K901 mounting panel.

Reference logic or control handbook for additional module information and selection.



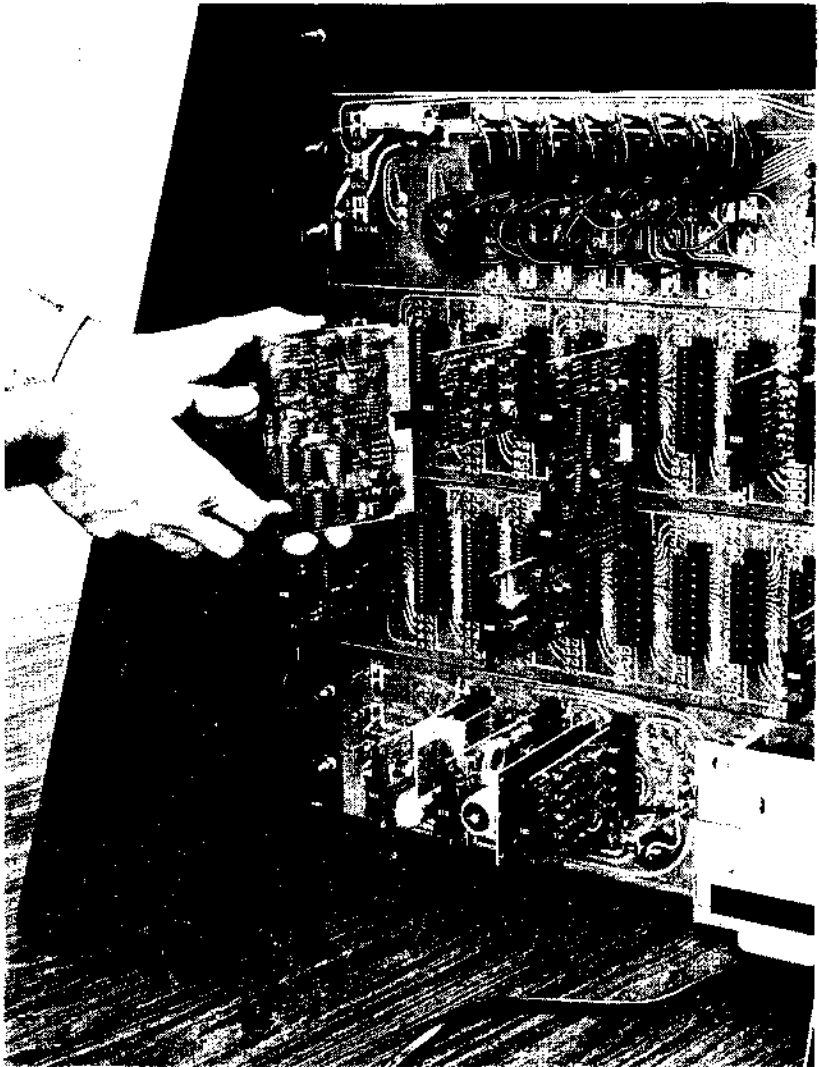

A rear view of the K Series Logic Lab shows how modules are plugged into mounting panels.

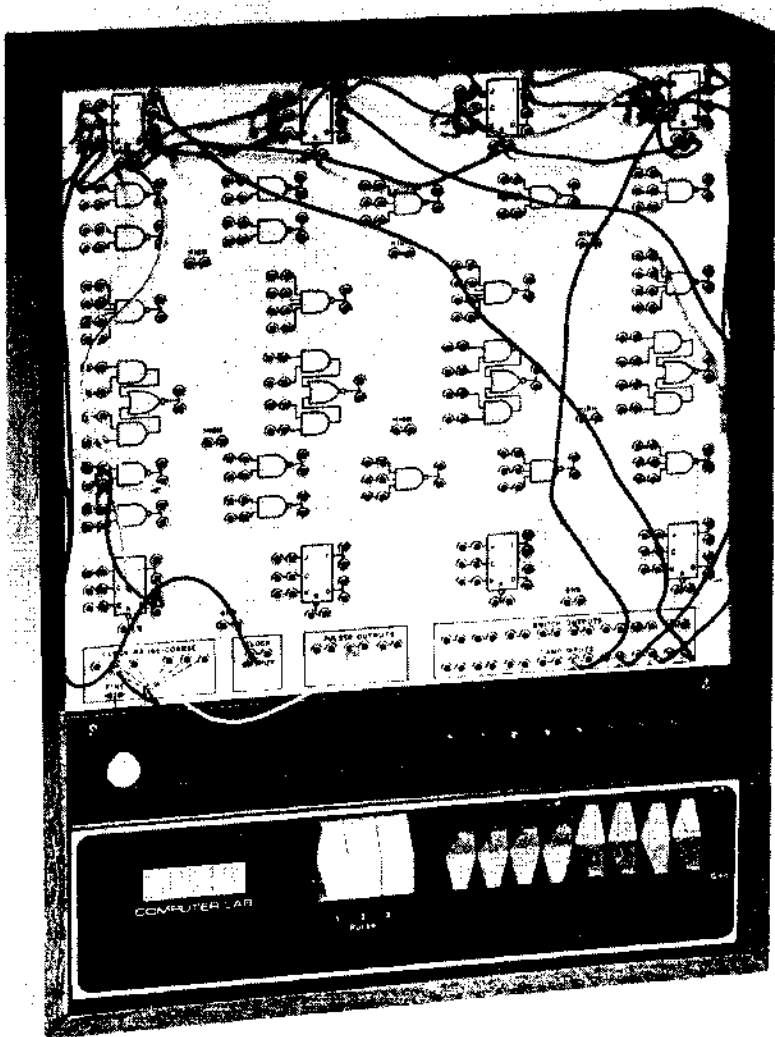

**COMPUTER LAB**

The **COMPUTER LAB** is a high performance low-cost digital logic trainer. It uses the same monolithic integrated transistor-transistor logic circuitry used in **DIGITAL's** latest computers.

The digital logic fundamentals presented by the **COMPUTER LAB** can foster a basic understanding of computer technology for the computer career oriented user, or for a user applying computers for the first time. The **COMPUTER LAB** will also help the math-oriented user understand "new math" concepts, as computer logic operates with binary numbers according to Boolean algebraic laws.

Wiring is easy because of the standard logic symbology used on the front panel and the color coded Patchcords which are easily inserted and removed. An improper circuit will not damage the **COMPUTER LAB**. The faulty circuit merely "waits" for correction.

**Features:**

- Transistor—Transistor logic circuitry as used in **DIGITAL's** PDP computers
- Teaches modern computer logic
- Easy to use: MIL-STD 806 logic symbology on front panel
- Portable: Dimensions of 12½" x 17" x 3¼", weighing only 11 lbs.
- Comprehensive Workbook provides:
  - Ten detailed chapters
  - More than 30 experiments
  - Over 200 hours of laboratory study
  - Dozens of tables and diagrams
  - An extensive appendix of supplementary information
- Instructor's Guide with answers, additional text, extra problems, course plans, at only \$5.00
- Low cost: **COMPUTER LAB**, Workbook and Patchcord set, ready to use \$445.00



DEC has more than 1.5 million square feet of manufacturing space. This view shows a portion of a module assembly area.

# About Digital Equipment Corporation

In a little over a decade, Digital Equipment Corporation has grown from three employees and one floor of production space in a converted woolen mill, to a major international corporation. DEC now employs more than 5500. Our products are manufactured in several plants, and are sold and serviced from customer support centers in the United States, Canada, Japan, Australia and seven European countries.

We produce a wide variety of computer and control products ranging from logic modules to large time sharing computer systems. In addition to the control logic modules detailed in this handbook, DEC also manufactures lines of computer design and interface modules; 12-, 16-, 18- and 36-bit computers, peripheral devices; special systems; accessories; and a wide variety of software.

DEC first began manufacturing computer-related equipment in 1957 when we introduced a line of solid state logic modules. These were initially used to test and build other manufacturers' electronic equipment. The logic module product lines have been continually broadened, and DEC now ranks as the world's largest manufacturing supplier of digital logic modules, producing more than three million per year.

Our first computer, the PDP-1 was introduced a decade ago, selling for \$120,000 while competitive machines were priced over \$1 million. Ever since the PDP-1, DEC has specialized in on-line, real-time computers.

The PDP-5, introduced in 1963, was the first truly small computer. The PDP-8 series, the PDP-5 successor announced in 1965, is one of the most popular and successful families of computers ever produced. More than 7500 are now installed.

DEC is a leading force in small computers, but it also has been a pacesetter in other parts of the industry. For example, one of the first time sharing systems ever built incorporated a PDP-1. DEC introduced the first large-scale, commercially available time sharing system in 1965—the PDP-6. Its successor, the PDP-10, can do more at a price well under \$1 million than competitive systems costing several times as much.

With more than 9,000 computers now installed, DEC is the third largest manufacturer in terms of installations.

In industry, DEC computers provide engineers with a powerful control and testing tool. They control blast furnaces and open hearths, monitor slab mills and finishing mills, and control and monitor a variety of machine tools, transfer, and material handling equipment. DEC computers assisted in the analysis of lunar rock samples, guided the SS MANHATTAN as she sailed the Northwest Passage, and are being used in testing the Boeing 747 jumbo jet, and the Anglo-French Concorde supersonic airplane.

In science, our computers have cut the researchers experiment time with direct, on-line data reduction. DEC computers control and monitor powerful nuclear reactors, control X-ray diffractometers, and analyze nuclear spectroscopy data. They are used extensively in environmental research and pollution control.

In virtually all DEC computer installations, DEC solid state logic is used for interfacing or control application.

## GENERAL INFORMATION

### FINANCIAL RESULTS

Total Sales (in millions)		Net Income (in millions)	
1970	\$ 135.4	1970	\$ 14.4
1969	\$ 91.2	1969	\$ 9.4
1968	\$ 57.3	1968	\$ 6.8
1967	\$ 38.8	1967	\$ 4.5
1966	\$ 22.7	1966	\$ 1.9

### MAIN PLANT & CORPORATE HEADQUARTERS:

146 Main Street, Maynard, Massachusetts  
(617) 897-5111

1,000,000 square feet

## OTHER MANUFACTURING FACILITIES

Carleton Place, Ont., Canada .....	40,000 square feet
Leominster, Mass. ....	60,000 square feet
Reading, England .....	25,000 square feet
San German, Puerto Rico .....	58,000 square feet
Westfield, Mass. ....	260,000 square feet
Westminster, Mass. ....	260,000 square feet
<b>TOTAL EMPLOYEES</b> .....	<b>5,900</b>
Sales, Service and Support .....	1,400
Manufacturing .....	2,700
Engineering, Marketing, Programming .....	600
General and Administrative .....	1,200



DEC's new PDP-8/E

## GENERAL DESCRIPTIONS OF DEC PRODUCTS

(Excluding those discussed in this Handbook)

### COMPUTERS

**PDP-8/E** The all new, lower cost successor to the PDP-8/I and PDP-8/L. It is the outgrowth of the largest concentration of minicomputer engineering, programming and user expertise in the world. Among the PDP-8/E features are: a unique internal bus system called OMNIBUS™, which allows the user to plug memory and processor options into any available slot location; the availability of 256 words of read only or read/write memory; a 1.2 microsecond memory cycle time; the use of TTL integrated circuitry with medium scale integration; expansion to 32,768 12-bit words; low cost mass storage expansion with DECdisk or DECTape.

**PDP-11** An expandable general purpose computer with 4,096 basic words of standard core memory, each word 16 bits in length. Memory cycle time is 1.2 microseconds. Machine uses integrated circuitry and has some medium-scale integration in central processor.

**PDP-12** Laboratory computer system capable of executing PDP-8 and LINC-8 programs. It has basic 4,096-word core memory. Each word is 12 bits in length. Basic laboratory system includes interactive graphics capability, magnetic tape storage, A/D converter, and pre-wired, real-time clock.

**PDP-15** A medium-scale series with an 18-bit word length. Four basic versions: PDP-15/10, PDP-15/20, PDP-15/30, and PDP-15/40.

**PDP-10** General purpose large computer with basic memory of 8,192 (36-bit) words, expandable to 262,144. Will handle up to 63 time-sharing users simultaneously with batch and real-time jobs at the same time.

### COMPUTER-BASED SYSTEMS

The following describes a sample of some of the hardware/software application systems available from DEC.

**INDAC-8** Small computer-based system for industrial data acquisition, process control, data logging, process monitoring and quality testing, uses simplified language designed for engineers, not programmers.

**680/I** Small computer-based data communications system built around PDP-8 family computers. It concentrates up to 128 teleprinter grade lines into one or more medium speed channels, drastically reducing the charges for telephone lines.

**LAB-8** Small computer-based data signal averaging system, used in biomedical, chemistry, and physics laboratories. Includes software for other functions.

**TSS-8** Small computer-based general purpose time-sharing system designed to accommodate up to 16 users with a variety of software for many tasks.

**TYPESET-8** Small computer-based system for setting type, producing punched tape containing all hyphenation, justification and format commands needed to set 12,000 lines of copy per hour.

**GLC-8** Small computer-based gas liquid chromatography system that will service 20 or more gas chromatographs simultaneously. It reduces and analyzes data accurately, repetitively and economically.



**CLINICAL-LAB-12** Real-time, on-line multiterminal small computer system designed to provide the clinical laboratory with an economical means of data collection, data reduction, and analysis.

**EDUCATIONAL SYSTEMS** These systems include computer and a variety of applications software. In the group are single language time-sharing systems and hardware/software calculator replacements.

**DISPLAYS** A variety of displays are available for all applications where the speed and flexibility of graphic communications increase system efficiency.

#### **SPECIAL SYSTEMS**

DEC's special systems group custom builds hardware and software systems for special applications.

#### **SOFTWARE**

A comprehensive line of software is available with DEC's hardware. Assemblers, debugging routines, editors, monitors, floating point packages and mathematical routines, diagnostic programs, are made available.

DEC has also developed such conversational, interpretive languages as: FOCAL®, an on-line language used as a tool by students, engineers and scientists in solving a wide variety of numerical problems; and DIBOL®, a business-oriented computer language designed to bring the speed and power of PDP-8 family computers to small and medium-size business establishments.

#### **OPTIONS & PERIPHERALS**

Analog/Digital converters, display and plotting equipment, drums and disks, magnetic tape equipment, card equipment, line printers, and many others.

#### **SUPPLIES**

Power supplies, cabinetry, mounting hardware, tape, tape reels, storage racks, teletype ribbon and paper.



DEC's large PDP-10 computer, a portion of which is shown here, is used in application ranging from financial management to commercial time-sharing to plant monitoring.

## WARRANTY

**WARRANTY 1—B, R, W, M, K, AND A MODULES** — All B, R, W, M, K, and A modules as shown in the Logic Handbook and Control Handbook, as revised from time to time, are warranted against defects in workmanship and material under normal use and service for a period of ten years from date of shipment providing parts are available. DEC will repair or replace, at DEC's option, any B, R, W, M, K, or A module found to be defective in workmanship or material within ten years of shipment for a handling charge of \$5.00 or 10 per cent of list price per unit, whichever is higher. Handling charges will be applicable from one year after delivery.

**WARRANTY 2—SYSTEM MODULES, LABORATORY MODULES, HIGH CURRENT PULSE EQUIPMENT, G, S, H, AND NON-CATALOG FLIP-CHIP MODULES** — All items referenced are warranted against defects in workmanship and material under normal use and service for a period of one year from date of shipment. DEC will repair or replace, at DEC's option, any of the above items found to be defective in workmanship or material within one year of shipment. Repair charges will be applicable from one year after delivery with repair charges varying depending on the complexity of the circuit.

The Module Warranty outside the continental U.S.A. is limited to repair of the module and excludes shipping, customer's clearance or any other charges.

Modules must be returned prepaid to DEC. Transportation charges covering the return of the repaired modules shall be paid by DEC except as indicated in previous paragraph, and will be made on a UPS basis, where available, or Parcel Post insured. Premium methods of shipment are available at customer's expense and will be used only when requested. If DEC selects the carrier, DEC will not thereby assume any liability in connection with the shipment nor shall the carrier be in any way construed to be the agent of DEC. Please ship all units to:

Digital Equipment Corporation  
Module Marketing Services  
Repair Division  
146 Main Street  
Maynard, Mass. 01754

No module will be accepted for credit or exchange without the prior written approval of DEC, plus proper Return Authorization Number (RA#).

All shipments are F.O.B. Maynard, Massachusetts, and prices do not include state or local taxes. Prices and specifications are subject to change without notice.

### DISCOUNT SCHEDULE

Aggregate List Price	Applicable Discount
\$ 5,000 - 9,999	3%
10,000 - 19,999	5%
20,000 - 49,999	10%
50,000 - 99,999	15%
100,000 - 249,999	18%
250,000 - 499,999	20%
500,000 - 999,999	22%
1,000,000 - AND OVER	25%

Discounts apply to any combination of FLIP CHIP Modules. Cabinets listed in catalog are discountable.

## PRICE LIST AND NUMERICAL INDEX

		PRICE	PAGE
A123	Positive Logic Multiplexer .....	\$ 58.00	184
*A160	8 Channel FET High Impedance Mux .....	250.00	186
*A161	8 Channel FET High Impedance Mux w/amp .....	375.00	188
*A162	8 Channel FET High Impedance Mux w/decoder .....	270.00	190
*A163	8 Channel FET High Impedance Mux w/decoder & amp. ....	395.00	192
*A164	8 Channel Constant Impedance Mux .....	350.00	194
*A165	8 Channel Constant Impedance Mux w/amp. ....	475.00	196
*A166	8 Channel Constant Impedance Mux w/decoder .....	365.00	198
*A167	8 Channel Constant Impedance Mux w/decoder & amp. ....	490.00	200
A207	Operational Amplifier .....	45.00	202
*A260	Dual Amplifier Card .....	300.00	204
A404	Sample and Hold .....	130.00	208
*A460	Sample and Hold w/o Input Buffer .....	400.00	210
A461	Sample and Hold with Input Buffer .....	525.00	210
A613	12-Bit DAC .....	200.00	212
A618	10-Bit D/A Converter Single Buffered .....	300.00	214
A619	10-Bit D/A Converter Single Buffered .....	325.00	214
A620	10-Bit D/A Converter Double Buffered .....	300.00	216
A621	10-Bit D/A Converter Double Buffered .....	375.00	216
*A660	Utility 12-Bit Multiplying DAC w/Register .....	500.00	218
A702	Reference Supply .....	58.00	220
A704	Reference Supply .....	175.00	220
A811	10-Bit A/D Converter .....	350.00	222
*A860	12-Bit Industrial Converter-Double Ramp .....	395.00	224
*A861	Unipolar High Speed A/D Converter .....	595.00	226
*A862	Bipolar High Speed A/D Converter .....	595.00	226
H001	Bracket .....	8.00	236
H002	Bracket .....	8.00	236
H020	Frame Casting .....	15.00	236
H021	End Plates .....	7.00	236
H022	End Plate Assembly .....	20.00	236
H704	Dual Power Supply .....	200.00	230
H707	Dual Power Supply .....	400.00	230
H710	Power Supply .....	200.00	159
H800	Connector Block .....	8.00	237
H802	Connector Block .....	4.00	238
H808	Connector Block .....	10.00	239
H810	Pistol Grip Wire-wrapping Tool .....	99.00	241
H811	Hand Wrapping Tool .....	21.50	242
H812	Hand Unwrapping Tool .....	10.50	242
H813	Hand Unwrapping Tool .....	30.00	240
H814	Hand Unwrapping Tool .....	21.00	240
H820	Grip Clip .....	48.00	242
H821	Grip Clip .....	75.00	242
H825	Hand Crimping Tool .....	146.00	242
H826	Hand Crimping Tool .....	210.00	242
H913	Mounting Panel .....	270.00	176
H914	Mounting Panel .....	125.00	176
H920	Module Drawer .....	170.00	244
H921	Front Panel .....	10.00	244
H923	Slide Tracks .....	75.00	244

## PRICE LIST AND NUMERICAL INDEX

	PRICE	PAGE
H925	Module Drawer	250.00 245
H941-AA	Mounting Panel 19"	175.00 246
H950-AA	Cabinet	152.00 248
K003	Gate Expander	5.00 28
K012	Gate Expander	8.00 28
K026	Gate Expander	8.00 28
K028	Gate Expander	8.00 28
K080	Cable Connector	3.00 31
*K112	Logic Gate	12.00 32
K113	Logic Gate	11.00 32
*K122	Logic Gate	13.00 32
K123	Logic Gate	12.00 32
K124	Logic Gate	14.00 32
K134	Inverter	13.00 43
K135	Inverter	13.00 44
*K138	Inverter	24.00 45
K161	Binary to Octal Decoder	25.00 46
*K171	Equality Comparator	13.00 49
*K174	Digital Comparator	24.00 50
K184	Rate Multiplier	25.00 52
K201	Flip-Flop	39.00 55
K202	Flip-Flop	27.00 56
K206	Flip-Flop Register	20.00 58
K210	Counter	27.00 59
K211	Programmable Divider	20.00 62
K220	Up/Down Counter	55.00 64
K230	Shift Register	40.00 68
K271	Retentive Memory	40.00 70
K273	Retentive Memory	85.00 72
K281	Fixed Memory	10.00 74
K282	Diode Matrix	40.00 76
K301	Basic Timer	15.00 77
K303	Timer	27.00 80
K323	One Shot	35.00 82
K333	Pulser	23.00 84
K371	Timer Control, Clock	11.00 86
K373	Timer Control, Clock	11.00 86
K374	Calibrated Timer Control	15.00 86
K375	Timer Control Clock	11.00 86
K376	Calibrated Timer Control	15.00 86
K378	Calibrated Timer Control	15.00 86
K410	Indicator Lights	18.00 92
*K415	Nixie Display	46.00 93
K420	Switches	33.00 95
K422	Thumbwheel Encoder	27.00 96
K424	Thumbwheel Decoder	27.00 98
K432	Timer Control	33.00 100
K501	Schmitt Trigger	25.00 103
K508	AC Input Converter	44.00 104
K522	Sensor Converter	25.00 107
K524	Sensor Converter	98.00 109
K531	Quadrature Decoder	70.00 114
K578	120 VAC Input Converter	80.00 117

## PRICE LIST AND NUMERICAL INDEX

		PRICE	PAGE
K580	Dry Contact Filter .....	28.00	120
K581	Dry Contact Filter .....	20.00	120
K596	EIA Input Converter .....	20.00	123
K604	Isolated AC Switch .....	110.00	124
K614	Isolated AC Switch .....	88.00	127
K615	Isolated AC Switch .....	92.00	130
K644	DC Driver .....	66.00	133
*K650	DC Driver .....	40.00	136
*K652	DC Driver .....	50.00	138
K656	DC Driver .....	80.00	139
K658	DC Driver .....	128.00	141
K671	Decimal Decoder & Nixie Display .....	55.00	143
K681	Lamp Driver .....	15.00	144
K683	Lamp Driver .....	30.00	146
K696	EIA Output Converter .....	44.00	148
K716	Interface Block .....	75.00	150
K724	Interface Shell .....	55.00	154
K730	Source and Control Module .....	19.00	155
K731	Source Module .....	30.00	157
K732	Slave Regulator .....	27.00	160
K741	Power Transformer .....	30.00	168
K743	Power Transformer .....	45.00	168
K771	Display Supply .....	35.00	170
K782	Terminal .....	12.00	171
K784	Terminal .....	17.00	171
K791	Test Probe .....	40.00	170
K900	Control Panel-Power Supply .....	185.00	384
K901	Patch Board Panel .....	125.00	385
K902	Indicator Switch Panel .....	145.00	386
K903	Patch Board Panel .....	155.00	387
K940	Mounting Hardware .....	4.00	173
K941	Mounting Hardware .....	6.00	173
K943	Mounting Panel .....	96.00	175
K950	Modular Mounting Hardware .....	39.00	177
K980	End Plates .....	6.00	178
K982	Mounting Panel .....	10.00	179
K990	Timer Component Board .....	4.00	180
911	Patchcords .....	9.00	385
913	Patchcords .....	18.00	242
914	Power Jumper .....	4.00	243
915	Patchcords .....	33.00	242
932	Bus Strip .....	0.60	240
933	Bus Strip .....	1.00	240
934	Wire-Wrapping Wire .....	50.00	240
935	Wire-Wrapping Wire .....	60.00	241
936	Conductor Ribbon Cable .....	0.60	241
1907	Cover .....	9.00	178
4913	Mounting Rack .....	25.00	388

\* New Modules

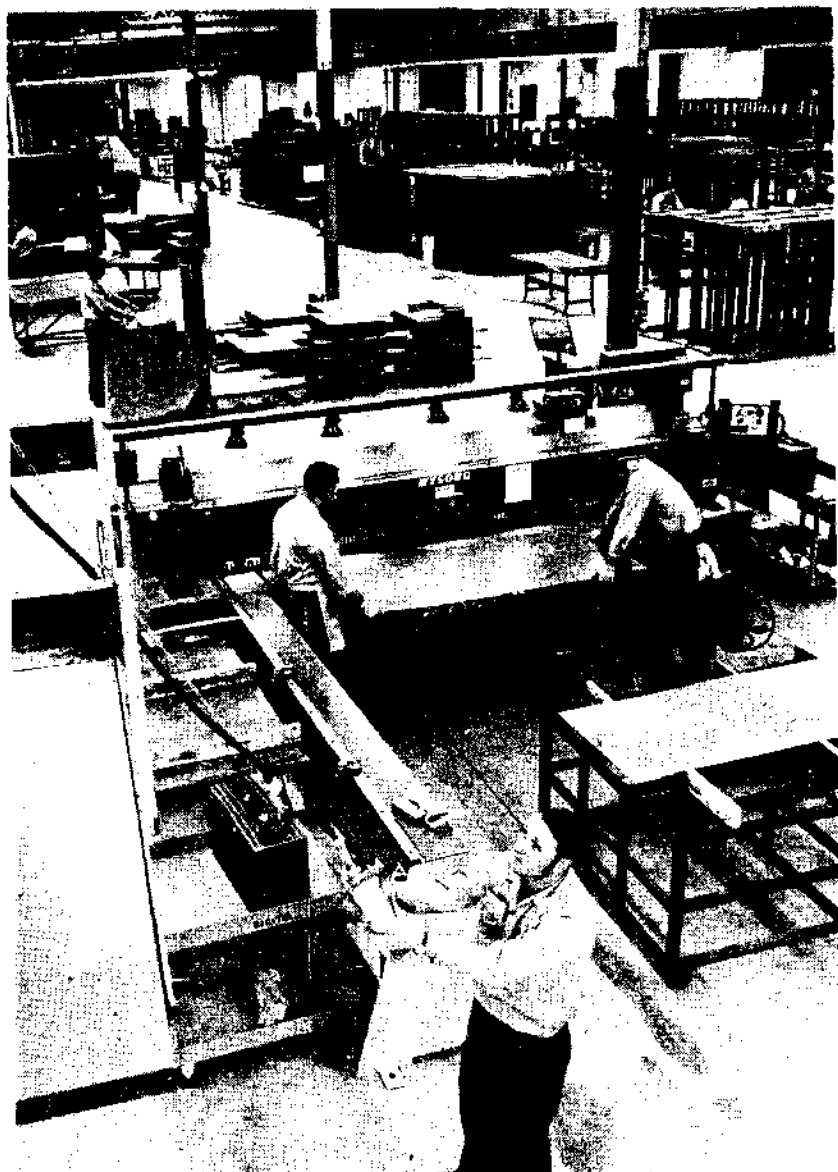

Cabinets for DEC systems are manufactured in this portion of DEC's recently opened Westfield, Massachusetts production facility

# INDEX

AC Input Converter	104, 107
Adder, Serial	320
Amplifier Card	204
Amplifier, Differential	107-113, 202, 204, 303
Amplifier, Operational	202, 204
Amplifier, Transducer	107-113, 202, 303
Analog-to-Digital Converters	222, 226, 297
Analog-to-Frequency Converters	329
Annunciators	311
BCD	46, 59, 62, 92, 94, 96, 98, 114, 143, 190, 191
Binary-to-Octal Decoding	46-48
Blank Modules	259
Brake Drivers	139, 141
Cable Connector	31
Cables	256
Cabinets	248-255
Clocks	63, 88, 89
Clutch Drivers	133-142
Comparator, Analog	109, 202, 204
Comparator, Digital	49-51
Computer Lab	392
Connector Blocks	237-239
Connector Mounting Bars	173, 236
Construction Recommendations	262-267
Contact Filters	120
Control Systems	380
Conversion, AC Input	104, 107
Conversion, Analog-to-Digital	222, 226
Conversion, Digital-to-Analog	212, 214, 216, 218
Conversion, K-to-M Series	295, 296
Conversion, M-to-K Series	295, 296
Conversion, Relay-to-K Series	268-285
Counters, Binary-coded Decimal	59, 62, 64
Counters, Parallel	310
Counters, Switch-tail Ring	324
Counters, Up-Down	64, 301, 319
Current Requirements-Modules	162-167
Decimal Counters	59, 62, 64
Decimal Decoders	99, 143
Decimal Indicators	92, 94, 143
Decoding-Digital	46, 98, 143
Delay	35, 77, 80, 82, 84, 100, 180, 190, 286, 293, 300
Differential Amplifier-Fixed Gain	202, 204
Digital Divider	55, 56, 59, 62, 64, 68
Digital Inputs	8
Direct Numerical Control	352
Discriminator, Frequency	293
Discriminator, Voltage	107-113, 303, 306
Displays	94, 143
Display Supplies	170

## INDEX

Divider .....	62
Drivers, Clutch/ Brake .....	133-142
Drivers, Indicator .....	144, 147
Drivers, Motor Starter .....	124, 126, 130, 133-142
Drivers, Relay/Solenoid .....	124, 126, 130, 133-142
Drivers, Stepper Motor .....	133-142
Drivers, Using .....	307
EIA Converters .....	123, 148
Encoding-Digital .....	96
End Plates .....	178
Equality- see Comparators	
Exclusive-OR .....	40
Expander, 8 Channel .....	194
Expander, Multiplexer .....	186, 194
Flip-Flops .....	42, 55-58
Gate Expanders .....	28-30, 36-39
Gates, Logic .....	32, 34
Hydraulic Valve Drivers .....	133-142
Hysteresis .....	13
Indicators .....	92
Indicator Drivers .....	144-147
Industrial Converter .....	224
Input Converters .....	103, 104, 107, 109, 114, 117, 120, 123
Input Loading .....	11
Integrator .....	318
Interface Shells .....	150, 154
Interface, Transducer .....	107, 109
Inverters .....	43, 45
Isolated AC Switches .....	124, 127, 130, 331
Lamp Drivers .....	144, 147
Limit Switch Inputs .....	104, 107, 120
Loading .....	11
Logic Lab-K-Series .....	383
Logic Symbols .....	18
M-Series Modules-inquire at nearest sales office	
Manual Controls .....	91-101
Memories .....	70,-76, 315
Module Characteristics .....	162-167
Module Drawers .....	244, 245
Module Extenders .....	257, 258
Module Summary .....	162, 167
Monostable Multivibrator .....	82
Motors, Servo .....	328
Motor Starts .....	124, 127, 130
Motor, Stepper .....	321-327



## INDEX

Mounting Hardware	173, 177, 236
Mounting Panel Frame	246, 388
Mounting Panels	179
Multiplexer Digital	52-54
Multiplexer, High Impedance	187, 190, 192
Multiplexer, Positive Logic	184
Multiplexer, Constant Impedance	196, 198, 200
Multiplier, Pulse Rate	52, 316, 317
NAND	40
Nixies	94, 143
Noise (electrical)	12
Nor	40
Numerical Control	352
Numerical Control Tape Preparation	338
Off-Delay	77, 80
On-Delay	77
One-Shot	77, 82
Operational Amplifiers	202, 204
Output Converters	124, 127, 130, 148
Output Loading	11
Panel, Control	384
Patch Cords	385
PDP-14/PDP-14L	360
Photocell Inputs	107, 113
Pneumatic Valve Drivers	133-142
Power Supplies	159, 230
Power Transformers	168
Pulse Amplifiers	77, 82
Pulse Generators	84, 300
Pulsers	84
Programmable Controller	360
Programmable Divider	62
Quadrature Decoders	114, 301
Quickpoint	338
Rate Multiplier	52-54, 316, 317
Real-time Clock	59, 63
Reference Supplies	220
Relay to K Series Conversion	268-285
Relay Drivers	124, 127, 130, 133-142
Retentive Memory	70, 72
Sample and Hold	208, 210
Schmitt Triggers	103
Sensor Converters	107-113, 303, 306
Sequencers	286-292
Servo Motors	328
Stepoint Control	293
Shift Registers	55, 58, 68, 324-326

## INDEX

Shift Registers, Bi-directional .....	324
Slave Regulator .....	160
Slowdown, Module .....	14, 35
Source and Supply Modules .....	155, 157
Starters, Motor .....	124, 127, 130
Stepper Motors .....	321-327
Switches and Filters .....	95, 120
Temperature Requirements .....	11
Terminals .....	171
Thermistor Inputs .....	107-113
Thumbwheel Switches .....	96, 98, 313
Timer Controls .....	84, 100, 180
Timers .....	77-81
Timing Requirements .....	12, 294
Training and Design Aides .....	382
Transducer Interfaces .....	107-113
Trimpots .....	107-113
Valve Drivers .....	133, 142
Warranty .....	400
Wire .....	240, 242
Wired AND .....	15, 41
Wire-wrap .....	233
Wiring Accessories .....	240, 244

FIRST CLASS  
PERMIT NO. 33  
MAYNARD, MASS.

**BUSINESS REPLY MAIL**  
**NO POSTAGE STAMP NECESSARY**  
**IF MAILED IN THE UNITED STATES**

Postage will be paid by:

**DIGITAL EQUIPMENT CORPORATION**  
**DEPT. A.**  
**MAYNARD, MASSACHUSETTS 01754**

(staple here)

## READER SURVEY AND INFORMATION REQUEST

We want to assure that future editions of this handbook and other information we prepare for you is as useful and informative as possible. We ask your assistance by completing and mailing this card to us. You may use this card also to request additional information.  
Thank you for your interest in DEC.

Your primary job function is \_\_\_\_\_

Your firm's principle product is \_\_\_\_\_

Did you get this book as a result of:

- Attending a trade show? Which one? \_\_\_\_\_  
 Advertising inquiry?  Editorial inquiry?  
Which publication? \_\_\_\_\_  
 From another person?

Have you ever used a previous edition of the Control Handbook?

- Yes  No Logic Handbook?  Yes  No

In this Control Handbook, did you read:

- Introduction?  Application Section?  Hardware Description?  
 Control Products Description?  Company Information?

Did you find the material:

- Too difficult?  Understandable?  Too basic?  Useful?

----- (please fold here) -----

What application do you or might you have for solid state control?  
\_\_\_\_\_

If you would like additional information on any DEC product please check the appropriate items:

Control Products:

- Logic Modules  
 PDP-14  
 Quickpoint-8  
 DNC  
Other \_\_\_\_\_

Computer Products:

- PDP-8/E  
 PDP-11  
 PDP-15  
 PDP-10  
 PDP-12  
Other \_\_\_\_\_

- PLEASE CHECK HERE IF YOU WOULD LIKE TO BE PLACED ON OUR CONTROL PRODUCTS MAILING LIST.

Name \_\_\_\_\_

Title \_\_\_\_\_

Company \_\_\_\_\_ Division \_\_\_\_\_

Street \_\_\_\_\_

City \_\_\_\_\_ State \_\_\_\_\_ Zip \_\_\_\_\_

**MAIN OFFICE AND PLANT**

16 Allen Street, Maynard, Massachusetts, U.S.A. 02154 • Telephone: From Metropolitan Boston 646-8600 • Elmhurst (617)-897-5211

TWX: 710-947-0212 Cable: DIGITAL MAYN Telex: 84-8667

**UNITED STATES**

**NORTHEAST**

**REGIONAL OFFICE**  
16 Lunds Street, Waltham, Massachusetts 02154  
Telephone: (617)-961-1100 TWX: 710-324-0919

**WALTHAM**  
16 Lunds Street, Waltham, Massachusetts 02154  
Telephone: (617)-961-0210/0215 TWX: 710-324-0919

**CAMBRIDGE/BOSTON**  
888 Main Street, Cambridge, Massachusetts 02139  
Telephone: (617)-491-8152 TWX: 710-320-1167

**ROCHESTER**  
130 Alstead Creek Road, Rochester, New York 14618  
Telephone: (716)-881-1700 TWX: 710-598-3211

**CONNECTICUT**  
1 Respage Drive, Meriden, Connecticut 06450  
Telephone: (203)-237-9441 TWX: 710-461-0054

**MID-ATLANTIC — SOUTHEAST**  
**REGIONAL OFFICE**  
U.S. Route 1, Princeton, New Jersey 08540  
Telephone: (609)-452-9150 TWX: 510-685-2328

**NEW YORK**  
85 Cedar Lane, Englewood, New Jersey 08625  
Telephone: (201) 871-4884, (212) 944-8955, (212) 738-0447  
TWX: 710-881-9721

**NEW JERSEY**  
1228 Route 46, Parapetony, New Jersey 07654  
Telephone: (201)-285-3000 TWX: 710-947-8919

**PRINCETON**  
Route One and Entomus Drive,  
Princeton, New Jersey 08540  
Telephone: (609)-452-7940 TWX: 510-685-2317

**LONG ISLAND**  
1818 Middle Country Road,  
Centerport, L.I., New York 11720  
Telephone: (516)-595-5410 TWX: 510-229-8006

**PHILADELPHIA**  
1328 West Valley Road, Wayne, Pennsylvania 19087  
Telephone: (215)-887-1405 TWX: 510-685-4461

**WASHINGTON**  
Executive Building  
7300 Baltimore Ave., College Park, Maryland 20740  
Telephone: (301)-778-1100 TWX: 710-626-8682

**DURHAM/CAROLINA**  
2704 Chapel Hill Boulevard  
Durham, North Carolina 27707  
Telephone: (919)-486-3247 TWX: 510-927-2912

**CANADA**  
Digital Equipment of Canada, Ltd.  
**CANADIAN HEADQUARTERS**  
180 Rossmore Street, Carleton Place, Ontario  
Telephone: (613)-257-7815 TWX: 510-581-1051

**OTTAWA**  
120 Neiland Street, Ottawa 3, Ontario  
Telephone: (613)-725-2163 TWX: 510-562-8600

**TORONTO**  
230 Lakeshore Road East, Port Credit, Ontario  
Telephone: (416)-778-8111 TWX: 510-492-4308

**MONTREAL**  
8675 Côte de Liesse Road  
Dorval, Quebec, Canada 780  
Telephone: 514-838-9383 TWX: 510-422-4124

**EDMONTON**  
8381-102 Street  
Edmonton, Alberta, Canada  
Telephone: (403)-434-8333 TWX: 510-431-2248

**VANCOUVER**  
Digital Equipment of Canada, Ltd.  
2210 West 12th Avenue  
Vancouver, British Columbia, Canada  
Telephone: (604)-736-5818

**EUROPEAN HEADQUARTERS**  
Digital Equipment Corporation International Europe  
81 Route De L'Air  
1227 Carouge / Geneva, Switzerland  
Telephone: 42 79 50 Telex: 22 983

**GERMANY**  
Digital Equipment GmbH  
**COLOGNE**  
5 Kasch, Bismarckstrasse 7, West Germany  
Telephone: 92 71 81 Telex: 896-2288  
Telegram: Flip Chip Koeln

**MID-ATLANTIC — SOUTHEAST (cont.)**

**HUNTSVILLE**  
Suite 41 — Holiday Office Center  
3222 Memorial Parkway S.W., Huntsville, Ala. 35801  
Telephone: (205)-861-7530 TWX: 810-726-2122

**ORLANDO**  
Suite 232, 6930 Lake Ellender Drive, Orlando, Fla. 32808  
Telephone: (305)-851-4450 TWX: 810-850-6180

**ATLANTA**  
Suite 116, 1790 Concourse Drive, N.W.,  
Atlanta, Georgia 30318  
Telephone: (404)-361-2622 TWX: 810-751-3251

**KNOXVILLE**  
5731 Lyons View Pike, S.W., Knoxville, Tenn. 37919  
Telephone: (615)-588-8571 TWX: 810-583-0723

**CENTRAL**  
**REGIONAL OFFICE**  
1260 Frontage Road, Northbrook, Illinois 60062  
Telephone: (312)-488-2580 TWX: 510-888-8083

**PITTSBURGH**  
405 Penn Center Boulevard  
Pittsburgh, Pennsylvania 15225  
Telephone: (412)-243-9500 TWX: 710-367-3657

**CHICAGO**  
1250 Frontage Road, Northbrook, Illinois 60062  
Telephone: (312)-488-2500 TWX: 510-888-8055

**ANN ARBOR**  
220 Horton View Boulevard, Ann Arbor, Michigan 48103  
Telephone: (313)-781-1130 TWX: 810-223-8053

**INDIANAPOLIS**  
21 Beechway Drive — Suite C  
Indianapolis, Indiana 46224  
Telephone: (317)-243-8341 TWX: 810-541-3438

**MINNEAPOLIS**  
15216 Minnetonka Industrial Road  
Minnetonka, Minnesota 55343  
Telephone: (612)-835-1244 TWX: 510-578-2818

**CLEVELAND**  
Park Hill Bldg., 26104 Euclid Ave  
Willoughby, Ohio 44094  
Telephone: (216)-946-9404 TWX: 810-427-2828

**ST. LOUIS**  
Suite 110, 115 Progress Pkwy., Maryland Heights,  
Missouri 63043  
Telephone: (314)-875-7520 TWX: 510-764-9831

**CENTRAL (cont.)**

**DAYTON**  
3151 Kettering Blvd., Dayton, Ohio 45426  
Telephone: (513)-269-7317 TWX: 810-659-1878

**DALLAS**  
8655 North Stemment Freeway, Suite 204  
Dallas, Texas 75247  
Telephone: (214)-438-3800 TWX: 910-461-4500

**HOUSTON**  
3417 Latam Street, Suite A, Houston, Texas 77002  
Telephone: (713)-524-2991 TWX: 910-371-1651

**WEST**  
**REGIONAL OFFICE**  
580 San Antonio Road, Palo Alto, California 94302  
Telephone: (415)-328-5640 TWX: 910-373-1286

**ANAHEIM**  
801 E. Ball Road, Anaheim, California 92705  
Telephone: (714)-778-9632 or (714)-625-7099  
TWX: 910-381-1150

**WEST LOS ANGELES**  
2022 Coover Avenue, Los Angeles, California 90025  
Telephone: (213)-478-3797 TWX: 910-342-8888

**SAN FRANCISCO**  
590 San Antonio Road, Palo Alto, California 94302  
Telephone: (415)-328-5640 TWX: 910-373-1286

**OAKLAND**  
Digital Equipment Corporation  
1205 Leggett Drive  
Oakland, California 94612  
Telephone: (415)-835-5453 (415)-835-7820  
TWX: 910-305-7238

**ALBUQUERQUE**  
8303 Indian School Road, N.E.  
Albuquerque, N.M. 87110  
Telephone: (505)-258-5411 TWX: 810-980-0412

**DENVER**  
2505 South Colorado Blvd., Suite #5  
Denver, Colorado 80222  
Telephone: 303-757-3352 TWX: 910-831-2850

**SEATTLE**  
1911 26th N.E., Bellevue, Washington 98004  
Telephone: (206)-854-4056 TWX: 910-443-2299

**SALT LAKE CITY**  
431 South 2nd East, Salt Lake City, Utah 84111  
Telephone: (801)-338-9638 TWX: 810-925-3834

**INTERNATIONAL**

**GERMANY (cont.)**

**MUNICH**  
8500 München 18, Leonrodstrasse 59  
Telephone: 518 32 54 Telex: 524228

**HANOVER**  
Digital Equipment Corporation GmbH  
3 Hannover, Podbielskistrasse 102  
Telephone: 0511-897-995 Telex: 922952

**ENGLAND**  
Digital Equipment Co. Ltd.  
**READING**  
Amersley Road, Reading, Berkshire, England  
Telephone: Reading 85133 Telex: 84927

**MANCHESTER**  
6 Upper Precinct, Worley  
Manchester, England M20 5BZ  
Telephone: 061-759-6411 Telex: 808806

**LONDON**  
Bliton House, Uxbridge Road, Ealing, London W5  
Telephone: 01-579-2781 Telex: 22377

**FRANCE**  
Equipment Digital S.A.R.L.  
**PARIS**  
253 Rue de Charonne, Paris 12, France  
Telephone: 544-75-07 Telex: 21238

**BENELUX**  
Digital Equipment N.V.  
(covering Belgium, Luxembourg, and The Netherlands)  
**THE HAGUE**  
Koninginnegracht 85, The Hague, Netherlands  
Telephone: 635900 Telex: 32533

**SWEDEN**  
Digital Equipment Aktieföretag  
**STOCKHOLM**  
Vretanvägen 2, S-171 56 Solna, Sweden  
Telephone: 08 390 13 90 Telex: 170 50  
Cable: Digital Stockholm

**SWITZERLAND**

Digital Equipment Corporation S.A.  
**GENEVA**  
61 Route De L'Air  
1227 Carouge / Geneva, Switzerland  
Telephone: 42 79 50 Telex: 22 983

**ITALY**  
Digital Equipment S.p.A.  
**MILAN**  
Corso Garibaldi, 49, 20121 Milano, Italy  
Telephone: 872 748, 872 884, 872 304 Telex: 32915

**AUSTRALIA**  
Digital Equipment Australia Pty. Ltd.  
**SYDNEY**  
75 Alexander St., Crown Hill, N.S.W. 2065, Australia  
Telephone: 426-2788 Telex: 20740

**WESTERN AUSTRALIA**  
643 Murray Street  
West Perth, Western Australia 6008  
Telephone: 21-4699 Telex: 91140

**BRISBANE**  
138 Adelaide Street, South Brisbane  
Queensland, Australia 4001  
Telephone: 4647 Telex: 40616

**MELBOURNE**  
80 Park Street, South Melbourne, Victoria, 3205  
Telephone: 84-6142 Telex: 30700

**WESTERN AUSTRALIA**  
643 Murray Street  
West Perth, Western Australia 6008  
Telephone: 21-4699 Telex: 91140

**WESTERN AUSTRALIA**  
138 Adelaide Street, South Brisbane  
Queensland, Australia 4001  
Telephone: 4647 Telex: 40616

**JAPAN**  
**TOYKO**  
Ravi Trading Co. Ltd. (sales only)  
Kasato-Kaikan Bldg.  
No. 19-14, Nishishimbashi 1-chome  
Minato-Ku, Tokyo, Japan  
Telephone: 591-5248 Telex: 381-6208

Digital Equipment Corporation International  
Kowa Building No. 17, Second Floor  
2-7 Nishi-Azabu 1-Chome  
Minato-Ku, Tokyo, Japan  
Telephone: 404-4884-1 Telex: TK-8028



The image shows a vertical strip of a book cover. The background is a textured, abstract pattern in shades of blue and green, resembling a marbled or wood-grain effect. A white title is printed vertically across the center of the strip. The title is split into two parts: the word "digital" is in a bold, sans-serif font with a grid-like pattern, and the words "control handbook 1971" are in a plain, sans-serif font.

**digital** control handbook 1971