

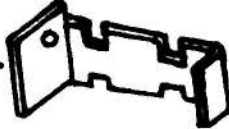

PARASITIC ENGINEERING

POWER SUPPLY KIT

Parts List

- 1 ea. 3729 transformer
- 1 ea. 3 ufd. @ 440 VAC capacitor
- 1 ea. MDA-3500 rectifier bridge
- 1 ea. VS-148 rectifier bridge
- 1 ea. Capacitor bracket 
- 1 ea. Rubber boot
- 1 ea. 2A. slow blow fuse
- 2 ea. 4" 14 gauge wire with fast-on connectors and lugs
- 1 ea. 6-32x3/8" machine screw
- 1 ea. 6-32x3/4" machine screw
- 3 ea. 6-32x1/2" machine nut

- 4 ea. #8 flat washer

- 2 ea. #6 lockwasher
- 1 ea. 5" insulation
- 1 ea. 5" bare hook-up wire 20 gauge
- 2 ea. Terminal block jumpers 
- 2 ea. Tie wraps
- 1 ea. Adhesive foam square
- 1 roll Solder wick
- 1 roll Solder

NOTE: More #6 nuts and lockwashers than necessary are supplied in case of loss.

Tools Needed

- 1 pair long nose pliers (4" or longer).
- 1 pair diagonal cutters (4" or longer).
- 1 pair wire strippers.
- 1 soldering iron (35 to 50 watt).
- 1 screwdriver (approx. 1/2" wide blade).

Limited Warranty

All Parasitic Engineering products are warranted against defects in materials for a period of ninety (90) days from date of delivery. During the warranty period, Parasitic Engineering will replace at no charge any components that prove to be defective.

This warranty does not apply to any components damaged by accident, misuse or improper assembly.

No other warranty is expressed or implied. Parasitic Engineering is not liable for any damages to equipment used in conjunction with its products, nor for consequential damages.

Parasitic Engineering
P.O. Box 6314
Albany, California 94706

ASSEMBLY INSTRUCTIONS

Save all hardware removed in the disassembly instructions.

- () Remove all plug-in boards from your Altair.

Refer to Figure 1 for the following steps:

- () Remove the four back panel mounting screws. Save these screws separately from the other hardware. The back panel will still be attached to the chassis with numerous wires, but the back panel can now be pulled out slightly. This will make the following steps easier.
- () Remove any I/O connectors mounted on the back panel.
- () Remove the twenty terminal screws, and all the lugs and wires, from the terminal block. Save these screws separately. Do NOT remove the four mounting screws.
- () Remove the screw that mounts the rectifier to the chassis.
- () Remove the four screws and other hardware that mount the power supply printed circuit board to the chassis. Save this hardware separately.
- () Remove the nine wires connecting the three transformers to the power supply board. Note: These wires go to the holes labeled WHT, RED, GRN, YELLOW, and ORNG.
- () Set aside the power supply board. You will work on it later.
- () The green wire from the power cord is connected to a lug on the side of the chassis. Remove the lug from the chassis.
- () The back panel should now be free from the chassis. Set the chassis aside.

- () Now remove transformers T1, T2 and T3 from the Altair back panel. Remember to save all the hardware.
 - () Referring to Figure 2, mount the constant voltage transformer to the back panel. Position the transformer with the smaller winding toward the bottom of the back panel. Use four 8-32"x1/2" or four 8-32"x 3/8" machine screws as shown. Each screw should have a flat washer and a lock washer installed before installing the nut. Use some of the hardware you removed in the previous step along with the washers supplied in the kit.
 - () Locate the capacitor bracket, and install it on the back panel as shown in Figure 2. Use the 6-32x3/8" machine screw supplied with this kit. Use a 6-32 nut and a #6 lockwasher that you removed earlier. Be sure to install this screw with the nut on the rear of the back panel, as shown in Figure 2. Otherwise the capacitor won't fit in the bracket.
 - () Locate the adhesive foam square, peel off the backing paper from ONE SIDE only. Position the foam square on the capacitor bracket, between the notches, and press it firmly in place.
 - () Peel the remaining backing paper from the foam square.
 - () Position the capacitor on the bracket, and press it firmly against the foam square.
 - () Locate the two tie wraps, wrap each of them around the capacitor and the bracket. Position them so that they fit into the notches on the bracket, then pull them tight and cut off the excess.
 - () Locate the MDA-3500 bridge. Refer to the insert of Figure 2 to identify the + and - terminals. Mount the bridge to the back panel with the terminals positioned as shown. Use the 6-32x3/4" screw, the 6-32x1/2" nut, and the #6 lockwasher supplied with this kit.
 - () Twist together the two black leads from the transformer. Position these leads from the transformer around the bottom of the transformer, and close along the side of the terminal block as shown in Figure 3.
 - () Connect one of the black leads to terminal 1, on the left side of the terminal block. Use one of the terminal screws you removed earlier.
 - () Connect the other black lead to terminal 2, on the left side of the terminal block. Use another one of the terminal screws.
- Note: If a fan is installed in your Altair, the fan power leads should be connected to terminals 1 and 2 of the terminal block.
- () Twist together the two violet leads from the transformer. Locate the rubber boot and slide it over the two violet leads.

- () Connect one of these violet wires to each terminal of the capacitor by slipping the fast-on connector over one of the lugs on the terminal. Caution: There are 2 lugs on each terminal. Be sure that both wires are not connected to the same terminal. Refer to Figure 3.
- () Now slip the rubber boot over the lugs on the top of the capacitor and dress the leads along the transformer.
IMPORTANT: The terminals of the capacitor have 400 volts across them when the computer is operating. Be sure the rubber boot is in place whenever the computer is in use.
- () Twist together the two green leads from the transformer. Route these wires as shown in Figure 3, and connect one wire to each of the unmarked terminals of the MDA-3500 bridge.
- () Locate the two terminal block jumpers. Use four of the terminal screws that you removed previously. Install the jumpers between terminals 7 and 8 and between terminals 9 and 10 of the terminal block, as shown in Figure 3. There should be NO connection between terminals 8 and 9.
- () Set aside the back panel.
- () Locate the power supply board. Refer to Figure 4 and locate D8. With a pair of diagonal cutters, cut the leads of D8 as close to the diode body as possible.
- () With your long nose pliers, gently grab hold of one of the diode leads then heat the lead from the other side of the board with your soldering iron. The lead should pull out as soon as the solder melts. Do not pull on the lead until the solder is fully melted.
- () Remove the other lead of the diode in the same manner.

Refer to Figure 4. Using the same procedure as above, locate the following parts and remove them:

Diodes:

- () D1
- () D2
- () D3
- () D4
- () D5
- () D6
- () D7
- () D9
- () D10

Capacitors:

- () C8
- () C13
- () C15

Resistors:

- () R2

Jumper:

- () J1

- () Now take the piece of solder wick provided and place one end of it on the bottom of the PC board over one of the holes of D8. Apply the soldering iron on top of the solder wick, directly over the hole. See Figure 5. After a few seconds the solder should begin to melt, and be sucked up into the solder wick. The hole should now be clear of solder. If a lot of solder is left, then try using a fresh area of the solder wick. If a small amount of solder is left, but the hole is still plugged, it may be easier to fill the hole with fresh solder and try again.
- () Repeat this procedure on the other hole of D8.

Using the solder wick clear the holes where you removed the following parts:

- () D7
- () D9
- () D10
- () C8
- () C13
- () C15
- () R2

- () Remove the rectifier by cutting its leads close to the body.
- () Remove the 4 rectifier leads from the board.
- () Remove the wire connected to hole +8B.

Cut the following lengths of 20 gauge bare wire and insulation:

Bare Wire:

- () 1½" () 1½"

Insulation:

- () ¾" () 1"

Refer to Figure 6 for the following steps:

- () Locate the holes you removed C13 from. Insert one end of the 1½" wire into the C13 hole furthest from the edge of the board. Slide the ¾" piece of insulation over the wire. Locate the holes you removed C15 from. Insert the other end of the 1½" wire into the C15 hole furthest from the edge of the board. Turn the board over and solder both ends of the wire. Cut off any excess leads.
- () Locate the holes you removed C8 from. Insert one end of the 1½" wire into the C8 hole furthest from the edge of the board. Slip the 1" piece of insulation over the wire. Locate the holes you removed R2 from. Insert the other end of 1½" wire into the R2 hole furthest from the edge of the board. Turn the board over and solder both ends of the wire. Cut off any excess leads.

- () Locate the VS-148 bridge. Refer to the exploded view in Figure 6 and locate the +, -, and unmarked leads. Cut two 3/4" pieces of insulation, slip the insulation over the indicated leads. Then bend the leads as shown.
- () Install the VS-148 bridge on the top of the power supply board. Insert the leads in the following holes:
The unbent, unmarked lead goes in the D8 hole nearest the band mark.
The - lead goes in the other D8 hole.
The + lead goes in the D7 hole nearest the band mark.
The bent, unmarked, lead goes in the D10 hole nearest the band mark.
Solder these leads and cut off the excess.
- () Position the back panel near the power supply board. Twist together the two yellow and the blue wires from the transformer. Route these wires along the left side of the transformer, under the violet wires, and against the back panel. Insert one of the yellow wires into each of the two holes marked yellow on the power supply board. Solder these wires in place, and cut off any excess leads. The blue wire will be connected later.
- () Position the back panel and the power supply board near to where they will be mounted on the chassis.

Install each lead on the terminal block as detailed below. Use the rest of the terminal screws that you removed earlier. A terminal number followed by an "R" refers to the right hand screw of that terminal. A terminal number followed by an "L" refers to the left hand screw of that terminal. Refer to Figure 7 for the terminal locations.

JUMPERS

- () Locate the two pre-made jumpers, and connect one of the jumpers from the + terminal of the MDA-3500 bridge to terminal 7R.
- () Connect the other jumper from the - terminal of the MDA-3500 bridge to terminal 9R of the terminal block.

TRANSFORMER

- () Connect the blue lead from the transformer to 10R of the terminal block.

MOTHER BOARD

- () Connect the wire from hole 1 of the mother board to terminal 8R of the terminal block. This is the +8V wire.
- () Connect the wire from hole 50 of the mother board to 10R of the terminal block. This is the GND wire.

- () Connect the wire from hole 2 of the mother board to 6R of the terminal block. This is the +16V wire.
- () Connect the wire from hole 52 of the mother board to 5R of the terminal block. This is the -16V wire.

FRONT PANEL CONTROL AND DISPLAY BOARD

- () Connect one of the "AC SW" wires from the front panel to 2L of the terminal block.
- () Connect the other "AC SW" wire to 3L of the terminal block.
- () Connect the wire from the +8V hole of the front panel to 8L of the terminal block.
- () Connect the GND wire from the front panel to 9L of the terminal block.

POWER CORD

- () The white lead from the power cord is connected to 1L.
- () The black lead goes to 4L.
- () Remount the green lead where it was originally mounted on the side of the chassis.

POWER SUPPLY BOARD

- () Connect one of the fuse wires coming from the power supply board to 3L.
- () Connect the other fuse wire to 4L.
- () Connect the wire from the -16V hole of the power supply board to 5L of the terminal block.
- () Connect the wire from the +16V hole of the power supply board to 6L of the terminal block.
- () The wire from hole +8A goes to 7L of the terminal block.
- () The wire from GND goes to 10L of the terminal block.
- () Install the remaining terminal screws in terminal numbers 1R, 2R, 3R, 4R, and 7R. There should be no wires connected to these terminals.
- () Remount the power supply board using the same hardware you removed earlier. Do not use any hardware where the rectifier was mounted.
- () Reinstall any I/O connectors that you removed earlier.

- () Remount the back panel using the same hardware that you removed before.
- () Replace the fuse with the 2 amp slow blow fuse supplied.
- () Reinstall the plug-in boards which were removed earlier.
- () Replace page 71, and the power supply schematic in your Altair Manual with the pages provided.

This completes the installation of your power supply kit.

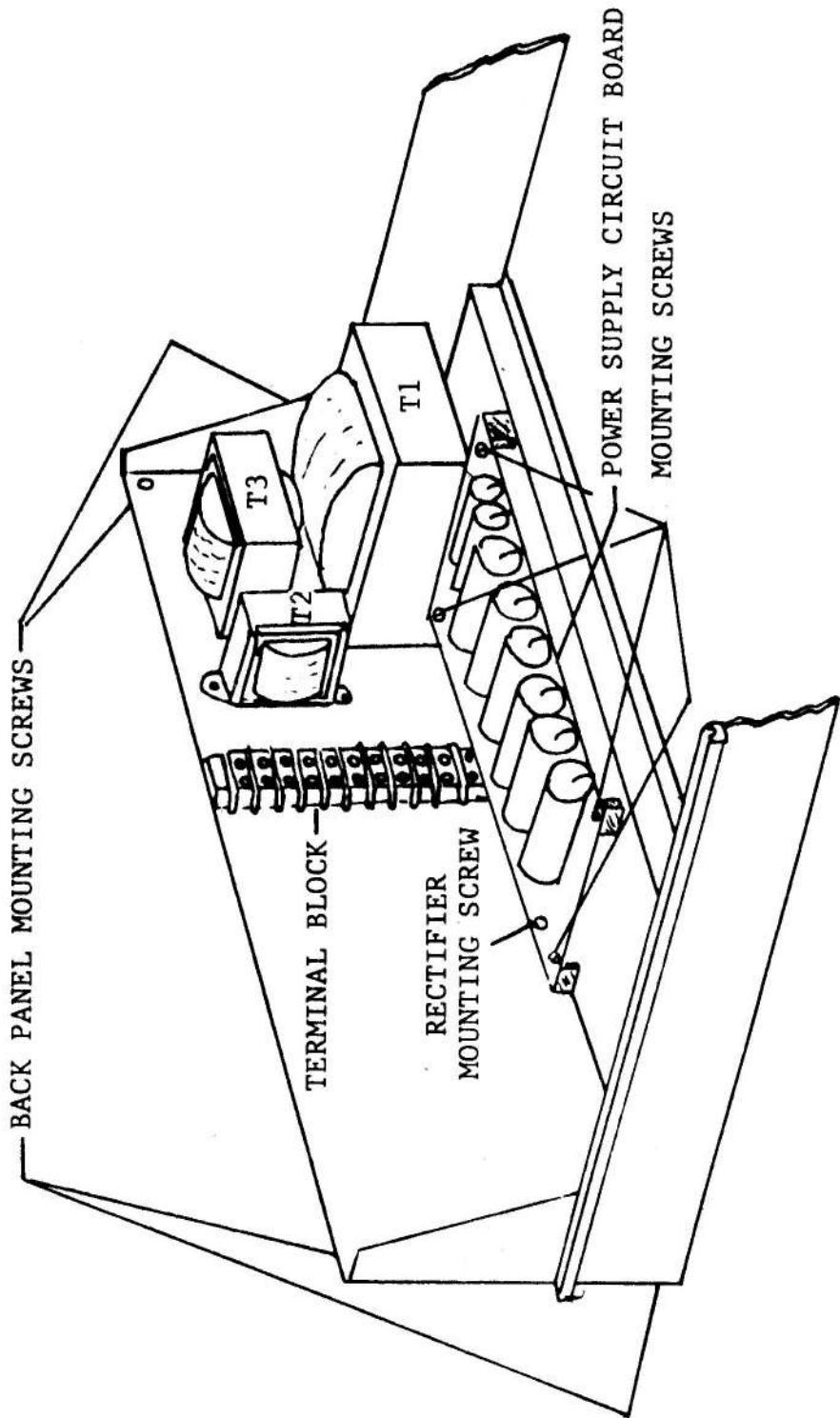
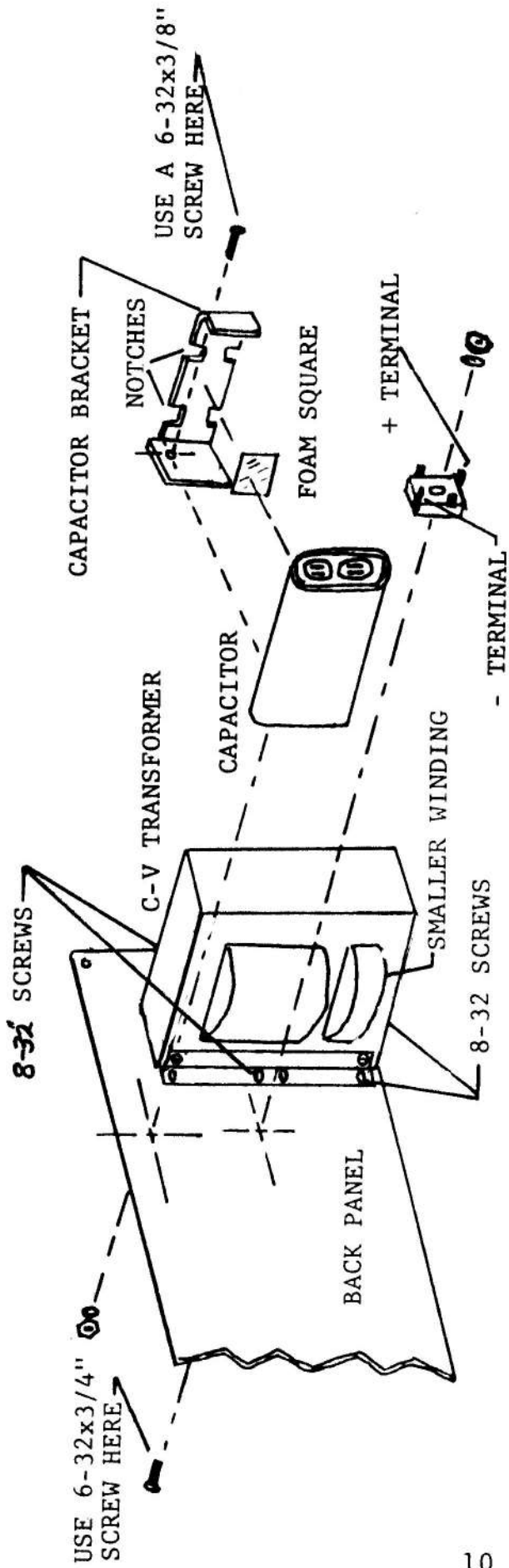
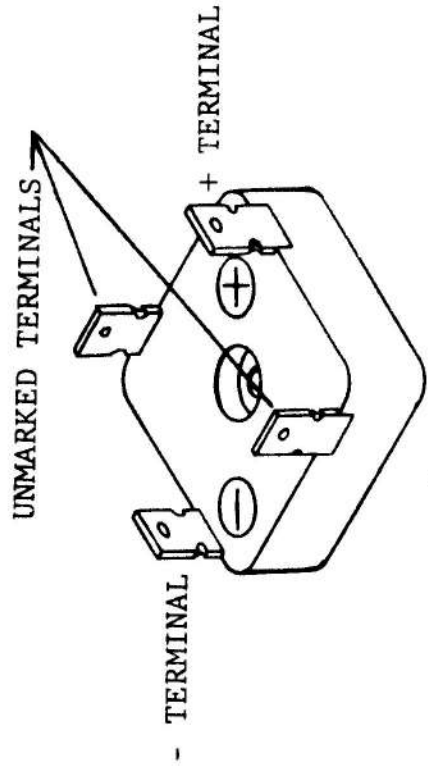

FIGURE #1



MDA-3500 BRIDGE



INSERT
MDA-3500 BRIDGE

FIGURE #2

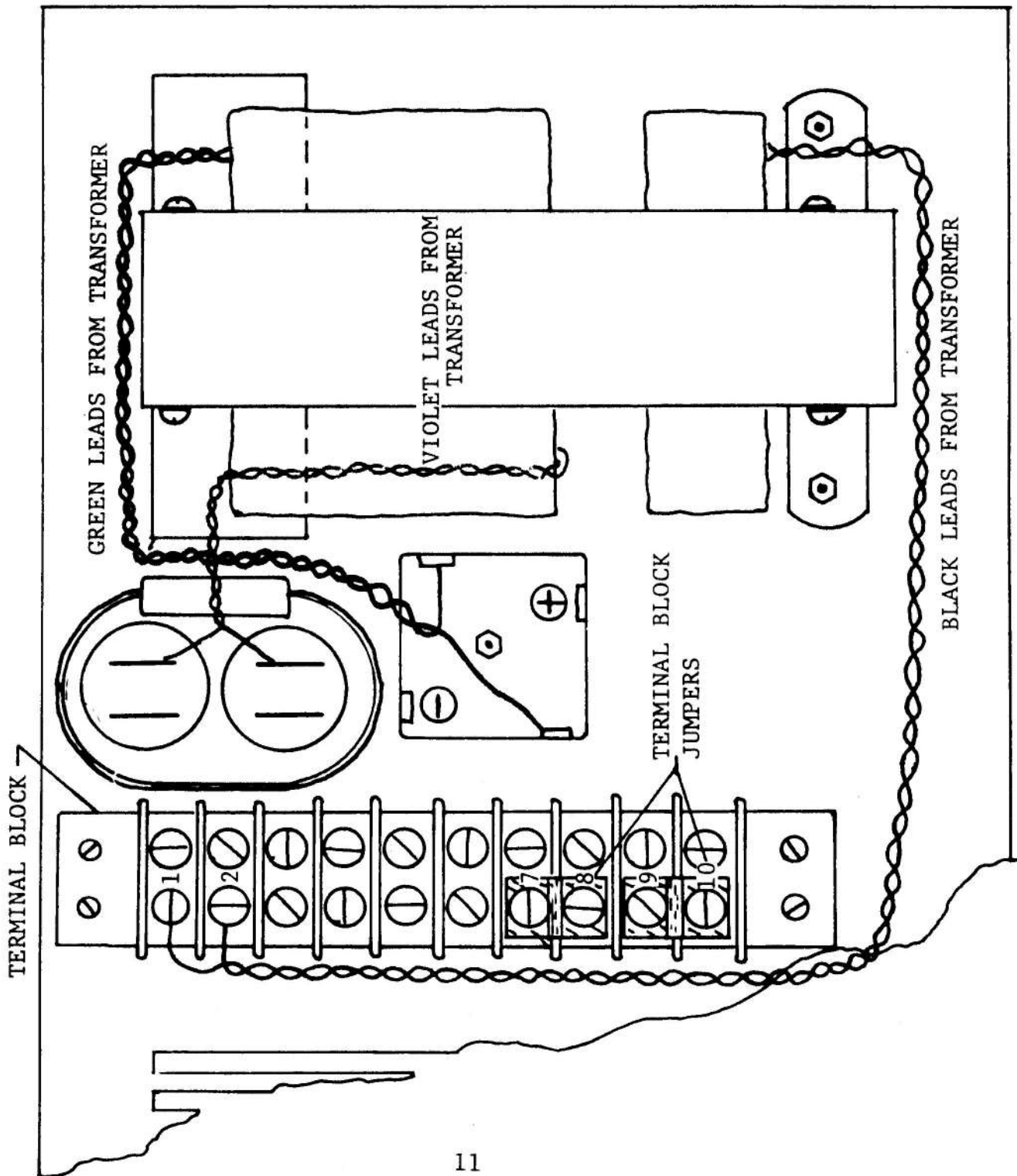

FIGURE #3

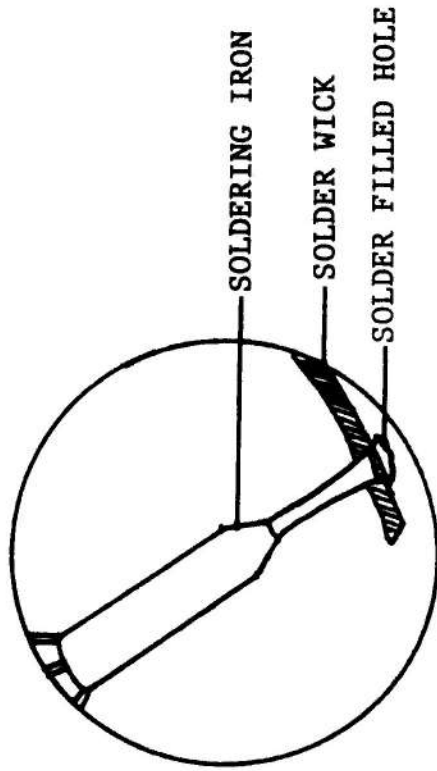

FIGURE #5

RECTIFIER (Mounted on bottom of board)

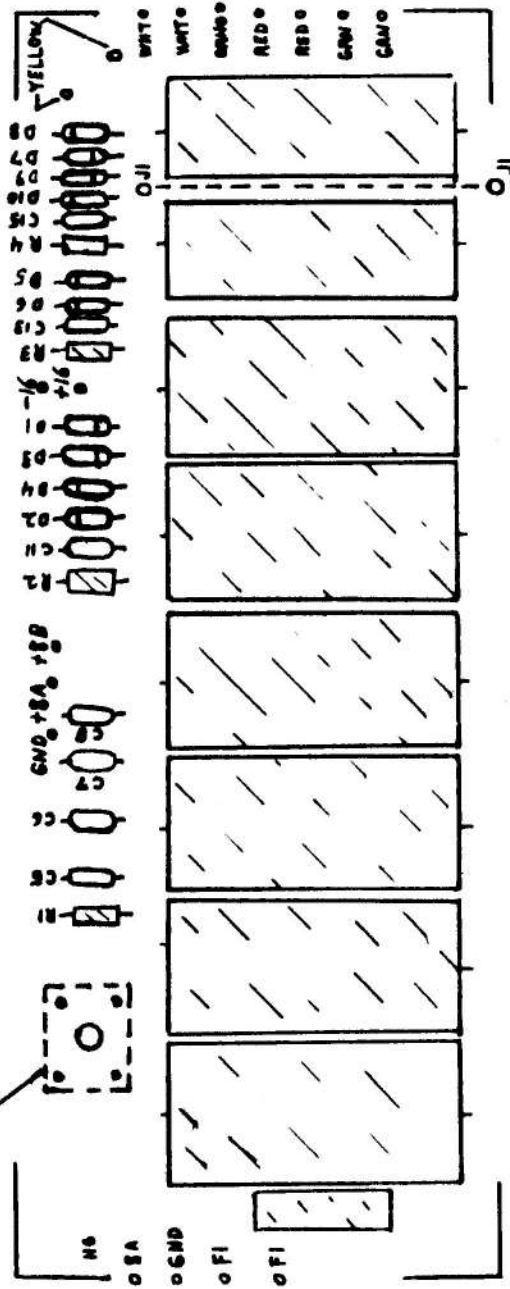
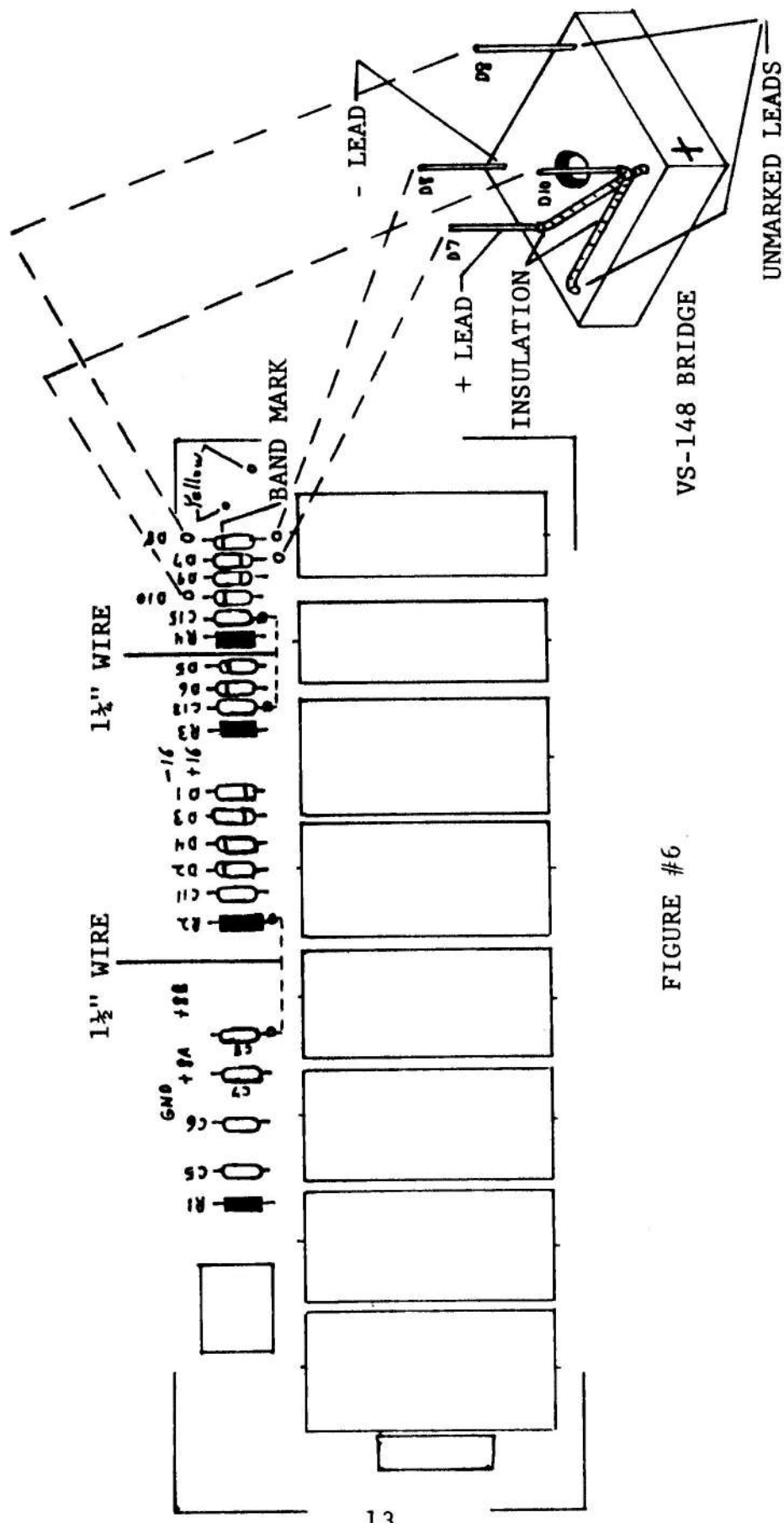

FIGURE #4



VS-148 BRIDGE

FIGURE #6

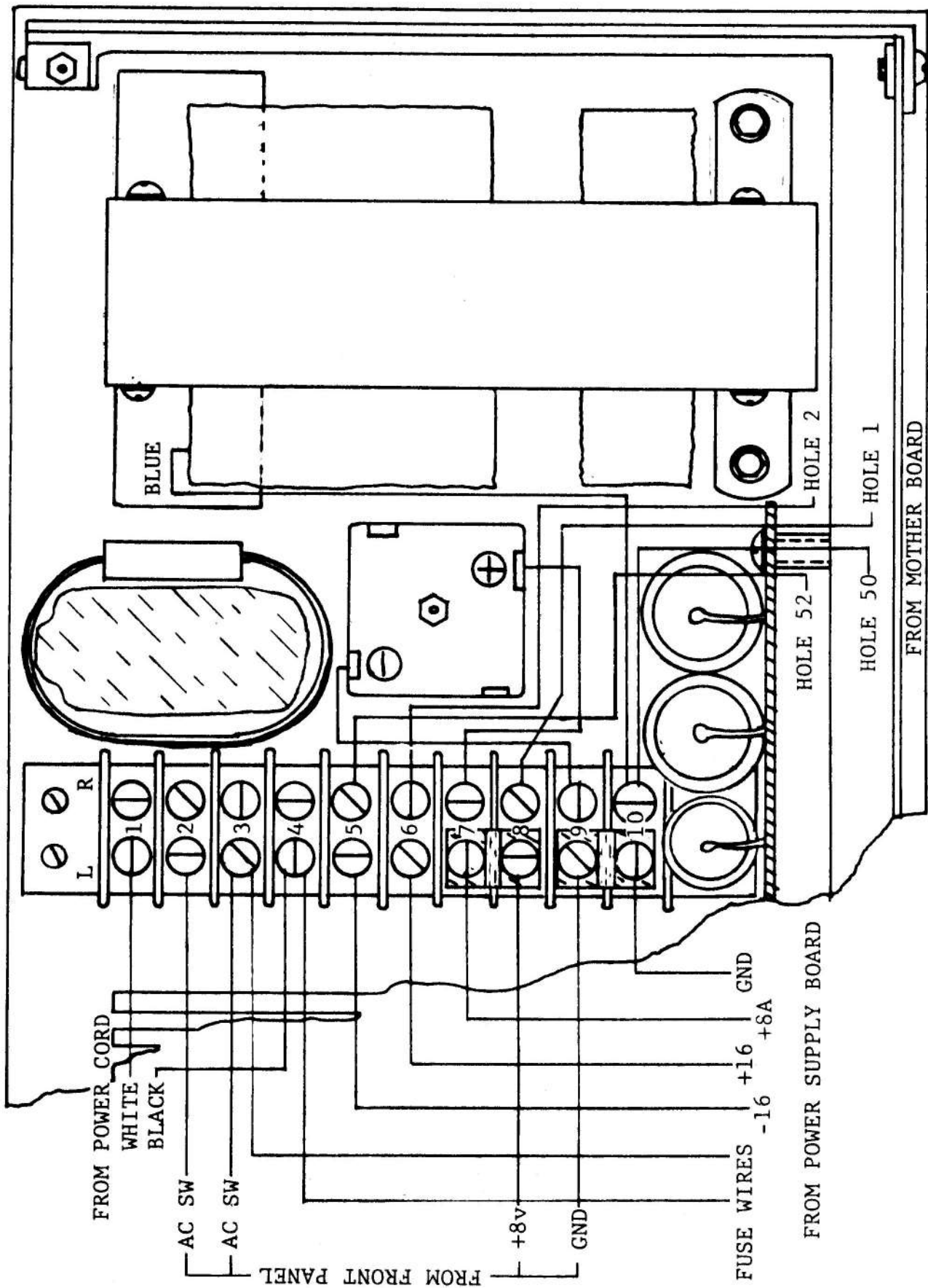
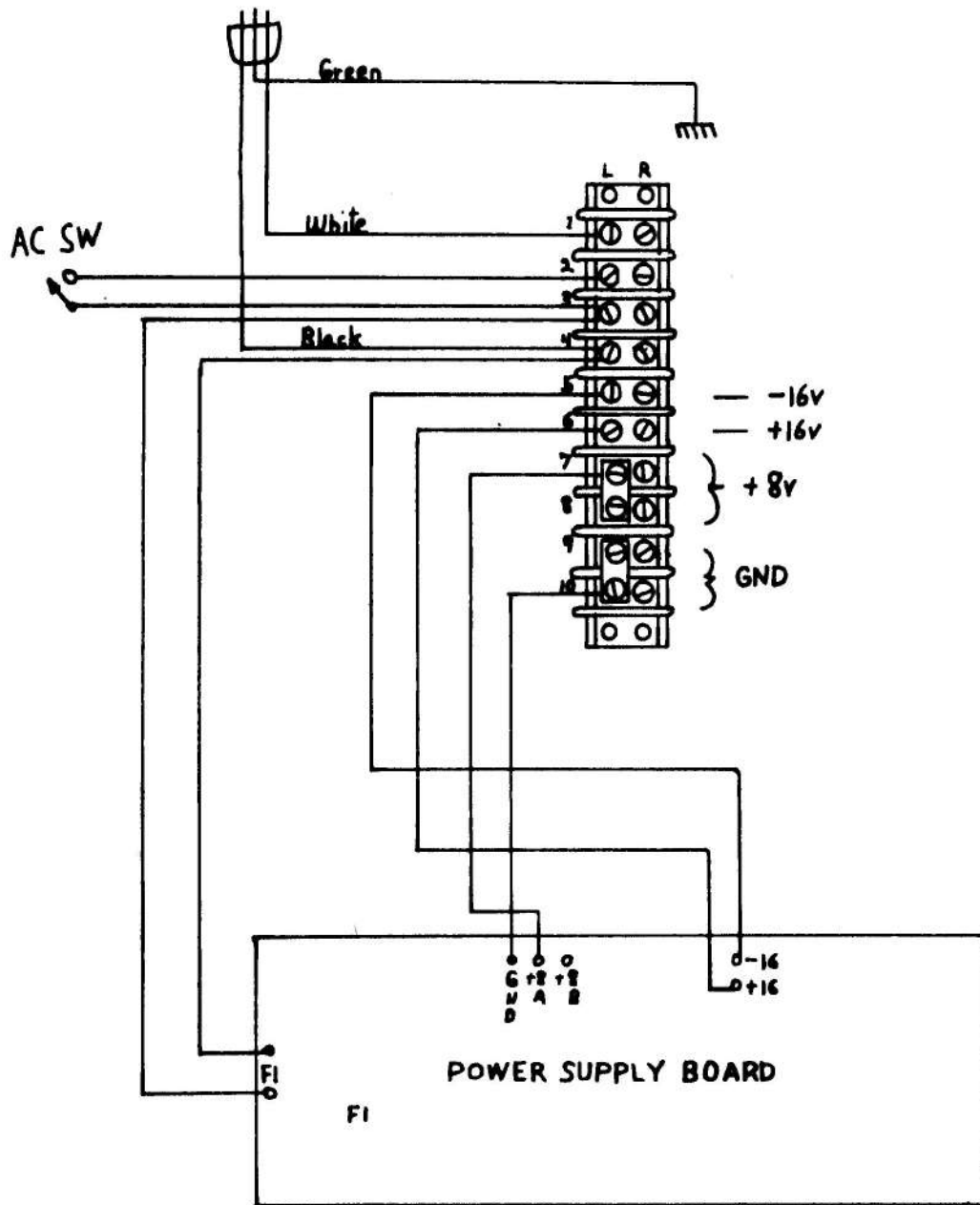

FIGURE #7



8800 BUSS STRUCTURE

<u>PIN</u>	<u>FUNCTION</u>	<u>PIN</u>	<u>FUNCTION</u>
1	+8v	51	+8v
2	+16v	52	-16v
3	XRDY	53	<u>SSW DSB</u>
4	VI0	54	<u>EXT CLR</u>
5	VI1	55	
6	VI2	56	
7	VI3	57	
8	VI4	58	
9	VI5	59	
10	VI6	60	
11	VI7	61	
12		62	
13		63	
14		64	
15		65	
16		66	
17		67	
18	<u>STAT DSBL</u>	68	MWRITE
19	<u>CIC DSBL</u>	69	<u>PS</u>
20	UNPROTECT	70	PROTECT
21	SS	71	RUN
22	<u>ADDR DSBL</u>	72	PRDY
23	<u>DO DSBL</u>	73	<u>PINT</u>
24	02	74	<u>PHOLD</u>
25	01	75	<u>PRESET</u>
26	PHLDA	76	PSYNC
27	PWAIT	77	<u>PWR</u>
28	PINTE	78	PDBIN
29	A5	79	A0
30	A4	80	A1
31	A3	81	A2
32	A15	82	A6
33	A12	83	A7
34	A9	84	A8
35	DO1	85	A13
36	DO0	86	A14
37	A10	87	A11
38	DO4	88	DO2
39	DO5	89	DO3
40	DO6	90	DO7
41	DI2	91	DI4
42	DI3	92	DI5
43	DI7	93	DI6
44	SMI	94	DI1
45	SOUT	95	DI0
46	SINP	96	SINTA
47	SMEMR	97	SWO
48	SHLTA	98	SSTACK
49	<u>CLOCK (2 MHZ)</u>	99	<u>POC</u>
50	GND	100	GND

PARASITIC ENGINEERING

PO BOX 6314

ALBANY CA 94706

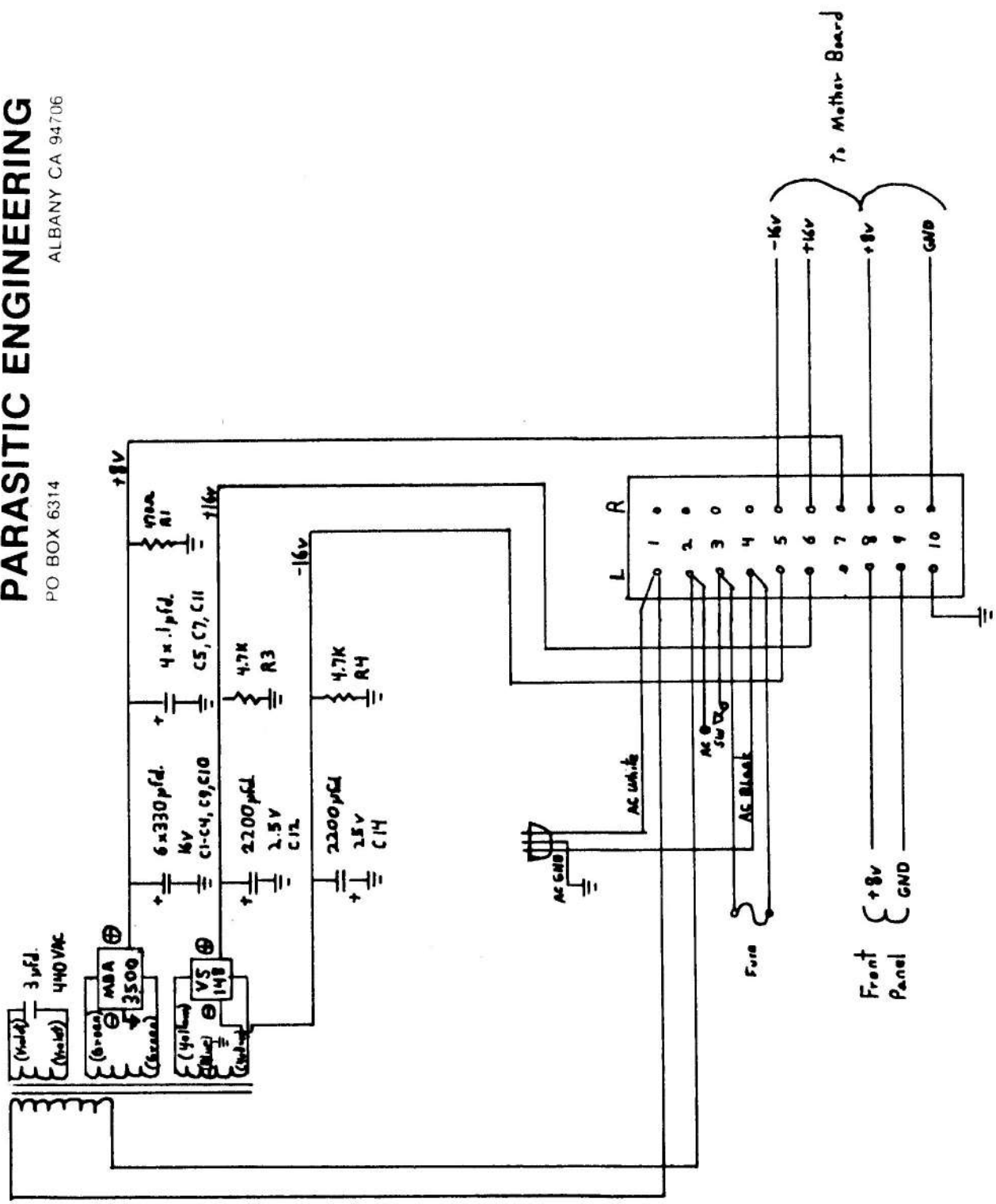

Note on Parasitic Engineering Power Supply Kit for the Altair 8800

Martin Eberhard 15 March 2010

There is a design mistake in this kit. As modified according to instructions, R4 does not connect to GND, but rather to +16V. R4's purpose is to drain the electrolytic capacitors on -16V. This mistake is likely to have only minor impact.

However, it is relatively simple to correct this mistake. Add the following steps to the end of the steps on page 4:

- () De-solder and lift the bottom end of R4 (the end farthest from the edge of the PC board).
- () Rotate R4 and solder the lifted end into the hole that was originally for the top end of C13 (the end closest to edge of the PC Board).