



NorthStarComputersInc.
2547 Ninth Street
Berkeley, Ca. 94710

MICRO-DISK SYSTEM MDS-A-D

DOUBLE DENSITY

Table of Contents

Introduction	2
Cautions	2
Limited Hardware Warranty	3
Out of Warranty Repair	3
Limited Software Warranty	4
Software License	4
Parts List	5
Assembly information	8
Figure IA: Identification of Components	10
Assembly and Check-out Instructions	11
System Integration	22
Theory of Operation	27
Appendix 1: Pulse Signal Detection	35
Schematic Drawings	36

Copyright 1978, North Star Computers, Inc.

MDS-D
REVISION 1

INTRODUCTION

The North Star Micro-Disk System (MDS-A-D) is a complete floppy disk system for use with S-100 bus computers. The system includes the disk controller board, one floppy disk drive, power regulation, cables, software and documentation. The software is provided on diskette and includes the North Star Disk Operating System, BASIC Language System, Monitor, and various utility programs. The system is capable of controlling up to four disk drives. Each disk drive can record 179,200 bytes of information on a diskette, thus allowing up to 716,800 bytes of on-line disk storage. Additional disk drives, AC power supplies, and cabinets are available as options

If you have purchased the MDS-A-D as a kit, then first skim the entire manual. Be sure to carefully read the Assembly Information section before beginning assembly. If you have purchased the MDS-A-D in assembled form, you may skip the Assembly section.

CAUTIONS

1. Correct this document from the errata before doing anything else.
2. Do NOT insert or remove the MDS controller from the computer while the power is turned on.
3. Do NOT insert or remove IC's from the board while the power is turned on.
4. Be sure the +5 volt and +12 volt regulators are generating the correct output voltages before installing any IC's.
5. Be careful to insert all IC's in correct positions and with correct orientation.
6. Do NOT connect or disconnect, mount or dismount, or in any way physically tamper with the disk drive, power board, or disk controller while the power is turned on.
7. In some cases disk drives may not operate properly if located in the vicinity of TV's, electric motors, or other sources of electrical noise. This may be remedied by moving the disk drive away from the noise source or by installing the disk drive in a grounded cabinet.

LIMITED HARDWARE WARRANTY

North Star Computers, Inc. warrants the electrical and mechanical parts and workmanship of this product to be free of defects for a period of 90 days from date of purchase. If such defects occur, North Star Computers, Inc. will repair the defect at no cost to the purchaser. This warranty does not extend to defects resulting from improper use or assembly by purchaser, nor does it cover transportation to the factory. Also, the warranty is invalid if all instructions included in the accompanying documentation are not carefully followed. Should a unit returned for warranty repair be deemed by North Star Computers, Inc. to be defective due to purchaser's action, then a repair charge not to exceed \$30 without purchaser's consent will be assessed. ANY UNIT OR PART RETURNED FOR WARRANTY REPAIR MUST BE ACCOMPANIED BY A COPY OF THE ORIGINAL SALES RECEIPT. This warranty applies to units located outside the United States of America only if all costs and arrangements for transportation of the product to and from the factory are borne entirely by the customer. This warranty is made in lieu of all other warranties, expressed or implied, and is limited to the repair or replacement of the product. No warranty, expressed or implied, is extended concerning the completeness, correctness, or suitability of the North Star equipment for any particular application. There are no warranties which extend beyond those expressly stated herein.

OUT OF WARRANTY REPAIR

If your unit is out of warranty and you are unsuccessful at diagnosing or repairing the problem, out-of-warranty service may be arranged with a local dealer or other experienced local computer technician. Alternatively, any North Star products may be shipped PREPAID to the North Star address with a clear written description of the problem. Include as many details as possible about the problem and about your system configuration. Your unit will be returned, C.O.D., within 30 days after receipt by North Star. Out-of-warranty repair service is billed at the rate of \$25.00 per hour. If you wish to place an upper limit on the amount of time spent on your unit, mention this in the written description.

LIMITED SOFTWARE WARRANTY

The following limited warranty applies to the North Star BASIC, DOS, and Monitor software delivered on diskette with the MICRO DISK SYSTEM. North Star Computers, Inc. warrants that a copy identical to the North Star master copy of the software has been stored on the customer diskette and can be read into computer RAM memory from the diskette by a properly functioning MICRO DISK SYSTEM using the North Star disk controller board and disk drive. If a diskette malfunctions and has not been damaged by the customer and has not been operated with the write-protect tab removed, then North Star will re-write or replace the diskette if it is returned to North Star, prepaid, within three months from date of purchase.

No warranty, expressed or implied, is extended concerning the completeness, correctness, or suitability of the North Star software for any particular application. No consequential damage resulting from use of the software is covered - this warranty is limited to the repair or replacement of the original software diskette.

SOFTWARE LICENSE

The North Star BASIC, DOS and Monitor are copyrighted products of North Star Computers, Inc., and are included with the MICRO DISK SYSTEM under the following license agreement:

The software may be used in conjunction with the North Star HORIZON computer and North Star MICRO DISK SYSTEM only. The customer may make copies of the software for convenience of use, as long as the North Star copyright notice is preserved with each copy. This license specifically prohibits use of the software in a computer which does NOT include a North Star disk controller board, and also specifically prohibits modification of the software for use in any system which does not contain a North Star disk controller board.

PARTS LIST

MDS SYSTEM PARTS

1 disk drive, Shugart SA-400 (double density)
1 ribbon cable assembly diskette, blank
1 diskette, pre-recorded with software
1 MDS-D Manual System Software Manual
1 OEM Manual
1 MDS controller with parts
1 MDS power board with parts
1 North Star name plate

MDS CONTROLLER PARTS

1 printed circuit board (5" x 10"), MDS-AD
5 20-pin IC sockets
19 16-pin IC sockets
22 14-pin IC sockets
1 34-pin cable connector header
1 crystal, 4MHz
6 1N4148 diodes
2 +5 volt regulators, 7805 or 340T-5
1 +12 volt regulator, 78L12
2 heat sinks, 6107B-14
2 6-32x3/8" machine screws
2 #6 lock washers
2 6-32 nuts

Integrated Circuits

2	74LS00	3	74LS241
1	74LS02	2	74LS253
1	74LS08	1	74LS257
1	74LS11	1	74LS273
2	74LS14	3	74LS393
1	74LS32	1	7404
6	74LS74	3	7438
3	74LS109	1	74166 or 74LS166
3	74LS123	1	DWE PROM (6301 or 82S129)
1	74LS138	1	DSEL PROM (6301 or 82S129)
4	74LS161	1	DPGM PROM (6309)
1	74LS164	1	LF356
1	74LS174	1	3080

Capacitors

4	2.2uf	tantalum
2	6.8uf	tantalum
1	.01uf	dipped mylar 10%
3	.022uf	dipped mylar 10%
1	.047uf	dipped mylar 10%
1	33pf	dipped mica 5%
1	100pf	dipped mica 5%
2	200pf	dipped mica 5%
2	330pf	dipped mica 1%
1	470pf	dipped mica 5%
1	47pf	ceramic disk 20%
1	100pf	ceramic disk 20%
1	330pf	ceramic disk 20%
18	.047uf	ceramic disk

Resistors

1	3.3	ohm	1/4W	5%	3	5.6K	ohm	1/4W	5%
5	150	ohm	1/4W	5%	1	6.19K	ohm	1/4W	1%
1	330	ohm	1/4W	5%	2	6.8K	ohm	1/4W	5%
4	470	ohm	1/4W	5%	1	9.1K	ohm	1/4W	5%
2	680	ohm	1/4W	5%	1	10K	ohm	1/4W	5%
3	2.2K	ohm	1/4W	5%	1	13K	ohm	1/4W	5%
1	3.3K	ohm	1/4W	5%	1	15K	ohm	1/4W	5%
1	3.6K	ohm	1/4W	5%	3	27K	ohm	1/4W	5%

MDS POWER BOARD PARTS

1	printed circuit board, 3" x 5 1/2"
2	capacitors, .047uf ceramic disc
1	regulator, 7805 or 340T-5
1	regulator, 7812 or LM340-12
1	heat sink, 6030B
3	heat sink, 690-3-B
3	machine screws, 6-32x3/8"
3	lock washers nuts, 6-32
1	power plug
4	power plug pins
1	4 conductor power cable, 5 feet
1	strain relief bushing
2	machine screws, 6-32x1 1/4"
2	spacers
1	ground wire with terminals, 5 feet

POWER SUPPLY PARTS (MDS-PS option)

1	115v cord set, 8 feet
1	strain relief bushing
1	fuse holder
1	fuse, 1A 3AG
1	toggle switch
1	transformer
1	capacitor, 3000uf 30wvdc electrolytic
1	capacitor, 3500uf 15wvdc electrolytic
2	rectifier diodes, MR501 3A
2	rectifier diodes, 1N4002 1A
2	machine screws, 6-32x3/8"
2	lock washers
2	nuts, 6-32
1	hook-up wire

CABINET PARTS (MDS-CAB option)

1	cabinet base plate
1	cabinet cover
4	stick-on rubber feet
4	6-32 flat head screws
6	6-32 pan head screws

ASSEMBLY INFORMATION

Read completely through each section before beginning the first instruction step of that section. Perform all operations in the sequence indicated. Read each step entirely, including any notes that accompany the step, before beginning to follow the step.

WORK AREA AND TOOLS

Start with a clean, well-lit and well-ventilated area to work. The area should be large enough to accommodate the kit, tools, parts and assembly instructions. Suggested tools are: screwdrivers, needle-nose pliers, diagonal cutters, soldering iron, solder, and masking tape. A number of tests will require using a VOM (ohmmeter-voltmeter), or VTVM. Also highly desirable, but not necessary, are an IC inserter, a screw-holding screwdriver, an oscilloscope or logic probe, and an extender card. [Note that if you do not have an oscilloscope or logic probe, waveforms can be detected by one of the procedures described in Appendix 1.]

SOLDERING TIPS

For best results use a 15 to 25 watt soldering iron or an iron with a temperature controlled tip (approximately 700 degrees). The tip should be no wider than the solder pads on the printed circuit board. Use only a fine gauge rosin core solder (60/40 or 63/37). Do NOT use acid core solder as this can severely damage a printed circuit board. When soldering, keep the soldering iron tip on the pad just long enough for the solder to completely flow. If the solder does not draw up the wire then more solder is required. Do not use so much solder that it overflows the pad. If a solidified joint is not shiny, it may be a cold solder joint and should be remelted. The soldering iron tip should be cleaned frequently by wiping on a damp sponge

When you have completed assembly of a board, inspect it for unintended solder connections or "bridges", as well as unsoldered leads. After soldering, it is recommended that the rosin flux be removed from the board using flux remover, FREON or paint-thinner type solvent. This will make looking for soldering problems easier and give the board a clean, professional appearance.

IC SOCKET INSTALLATION

Integrated circuit (IC) sockets can be installed by first inserting them into the printed circuit board, then placing another flat board over the IC sockets and finally turning over this sandwich. Be sure that each IC socket is inserted into the proper location and is oriented such that pin 1 of the socket corresponds to the pin 1 indication on the PC board layout legend. (Refer to figure 1A to identify pin 1 on an IC socket.) To solder IC sockets, first solder just two opposite corner pins

for all sockets being installed. Then remelt the corner connections while applying pressure down on the board. This will remove any gaps that may be present between the IC sockets and the PC board. Finally, solder the remaining pins of the IC sockets.

DIP HEADER SOLDERING

When making jumper connections on a DIP header, solder resistor or capacitor lead snippings between the leads to be connected. When more than two pins are to be connected together, bend a single wire so that it routes to each pin, and solder each pin once. Insert the header in an IC socket on a PC board to hold it during soldering. Overheating the pins with the soldering iron will melt the plastic of the header. If there are multiple jumpers on a header, make sure that no unintended connections are made by carefully routing the jumpers, or by insulating each jumper with some wire insulation.

RESISTOR AND CAPACITOR INSTALLATION

To install resistors or capacitors, first make right angle bends in the leads to fit the PC board hole spacing. (Some capacitor leads are already appropriately spaced and do not need bending.) Then insert the leads as far as possible through the correct holes in the PC board and spread the leads slightly on the solder side of the board to keep the part in place. After a group of resistors or capacitors has been inserted, then solder the leads on the solder side of the board and snip off the excess leads as close to the board as possible. Use caution to avoid eye injury from flying bits of wire. Save the lead clippings for later use in making jumper connections.

PRINTED CIRCUIT BOARD LAYOUT

The white component layout legend is printed on the component side of a printed circuit (PC) board. All components are inserted from this side (component side) and soldered on the other side (solder side). Locations on the PC board are identified by two-character codes as marked on the board: a digit followed by a letter indicating the horizontal and vertical coordinates of the location. Note that in North Star kits, IC's can be found on styrene pads in positions corresponding to their intended locations on the PC board.

Pin numbering conventions for the S-100 edge pins are as follows: When viewing the component side of the board (with the pin edge facing down), pins 1,2, ..., 50 range from left to right. When viewing the solder side of the board, pins 100, 99, ..., 51 range from left to right.

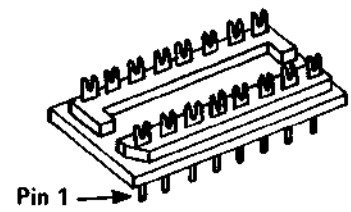
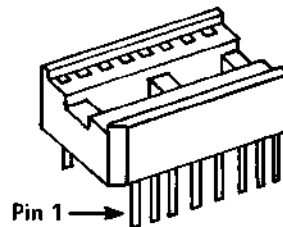
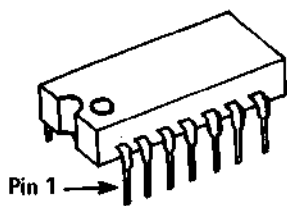
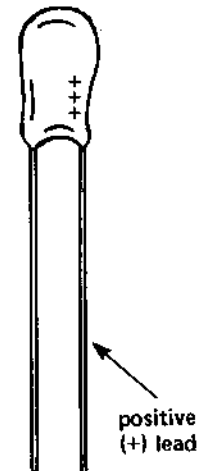
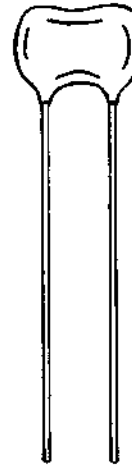
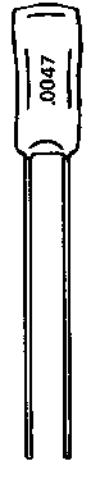
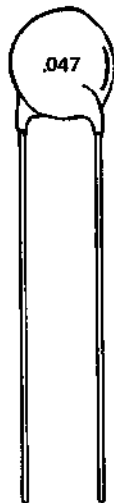
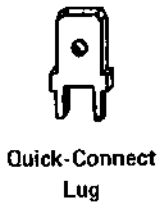
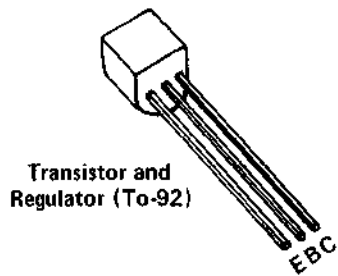
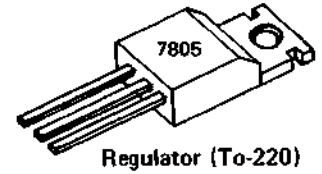
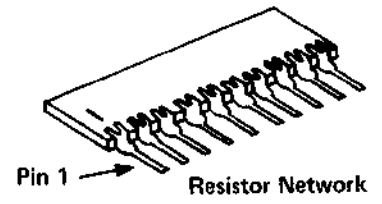
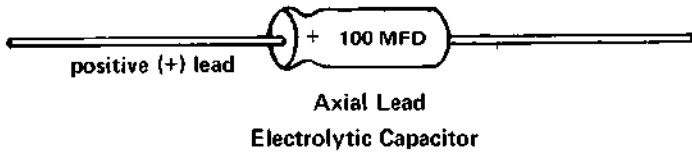

Figure 1A. Identification and orientation of components.

ASSEMBLY AND CHECK-OUT INSTRUCTIONS

DISK CONTROLLER BOARD ASSEMBLY

For best results, assemble the MDS controller using the following steps.

NOTE: Orient the board with the edge connector toward you and the heat sink area to the left. The component side is now up. The silk screen legend is on the component side.

- A1. Insert and solder the 5 twenty-pin IC sockets at locations 7D, 8D, 9D, 10D, and 11D, following the procedure given in the Assembly information section. Orient them as shown on the layout legend with pin 1 toward the bottom of the board.
- A2. Similarly, install the 19 sixteen-pin IC sockets. A sixteen-pin socket is used at location 1A. The two 8-pin IC's will be inserted into this socket.
- A3. Similarly, install the 22 fourteen-pin IC sockets.
- A4. Install and solder the 31 resistors in the locations indicated by the layout legend. The hole spacing for all the resistors is .5 inches.

Resistor	Location	Value	Size	Color-code
() R1	1A	3.3K	1/4W	org-org-red
() R2	1B	3.3	1/4W	org-org-gld
() R3	1C	5.6K	1/4W	grn-blu-red
() R4	2A	27K	1/4W	red-vio-org
() R5	2A	27K	1/4W	red-vio-org
() R6	2B	5.6K	1/4W	grn-blu-red
() R7	2B	6.19K 1%	1/4W	blu-brn-wht-brn
() R8	2B	2.2K	1/4W	red-red-red
() R9	3A	470	1/4W	yel-vio-brn
() R10	3A	470	1/4W	yel-vio-brn
() R11	3A	5.6K	1/4W	grn-blu-red
() R12	3A	3.6K	1/4W	org-blu-red
() R13	3C	6.8K	1/4W	blu-gry-red
() R14	3C	13K	1/4W	brn-org-org
() R15	3C	27K	1/4W	red-vio-org
() R16	3C	6.8K	1/4W	blu-gry-red
() R17	4B	2.2K	1/4W	red-red-red
() R18	14A	680	1/4W	blu-gry-brn
() R19	4A	9.1K	1/4W	wht-brn-red

() R20	5A	10K	1/4W	brn-blk-org
() R21	5D	470	1/4W	yel-vio-brn
() R22	6A	15K	1/4W	brn-grn-org
() R23	6D	2.2K	1/4W	red-red-red
() R24	6D	330	1/4W	org-org-brn
() R25	14A	680	1/4W	blu-gry-brn
() R26	11B	470	1/4W	yel-vio-brn
() R27	12A	150	1/4W	brn-grn-brn
() R28	12A	150	1/4W	brn-grn-brn
() R29	12A	150	1/4W	brn-grn-brn
() R30	14A	150	1/4W	brn-grn-brn
() R31	14A	150	1/4W	brn-grn-brn

A5. Insert and solder the 39 capacitors in the locations indicated by the layout legend. The tantalum capacitors have polarity, so care must be taken to insert the positive lead in the hole marked with a plus sign. The "+" lead of tantalum capacitors is marked with a "+" sign. Some capacitors are marked with a 3-digit code consisting of two significant digits followed by a power of ten expressed in picofarads. Thus, 223 means 22000pf or .022uf and 331 means 330pf. These alternate capacitor markings are given below in parentheses after the capacitor value.

Capacitor	Location	Value	Type
() C1	1C	6.8uf	tantalum
() C2	1C	2.2uf	tantalum
() C3	1D	6.8uf	tantalum
() C4	1D	2.2uf	tantalum
() C5	2D	2.2uf	tantalum
() C6	2D	2.2uf	tantalum
() C7	1A	.047uf(473)	dipped mylar
() C8	1B	100pf(101)	dipped mica
() C9	1C	.022uf(223)	dipped mylar
() C10	2A	.01uf(103)	dipped mylar
() C11	2B	330pf(331) 1%	dipped mica
() C12	3C	200pf(201)	dipped mica
() C13	3B	.022uf(223)	dipped mylar
() C14	3B	200pf(201)	dipped mica
() C15	4A	330pf(331) 1%	dipped mica
() C16	5A	.022uf(223)	dipped mylar
() C17	5D	330pf(331)	ceramic disc
() C18	5D	47pf	ceramic disc
() C19	11B	100pf(101)	ceramic disc
() C20	15A	33pf	dipped mica
() C21	15A	470pf(471)	dipped mica

The remaining eighteen .047uf(473) or .05uf(503) ceramic disc capacitors are bypass capacitors and should be installed in the oval capacitor locations marked with asterisks (*) on the layout legend.

- A6. Insert and solder the six 1N4148 diodes at the locations indicated by the layout legend. The end of the diode marked with a band is the cathode end and must be oriented as indicated by the layout legend.

Diode	Location	Orientation
() 1	2A	band at left
() 2	2A	band at right
() 3	2A	band at left
() 4	2A	band at right
() 5	3A	band at right
() 6	3A	band at left

- A7. Insert and solder the crystal at location 15A. Bend the leads so that the crystal will lie parallel with the PC board. In addition to the two leads, the crystal should be strapped to the PC board with a piece of clipped resistor lead which is soldered to the pads on either side of the crystal case.

- A8. Install each of the two heat sinks and 5 volt regulators at locations 1C and 1D as follows. Bend down the three leads of the 5 volt regulator 90 degrees such that the leads go into the correct holes while the machine screw holes line up. Don't solder yet. Fasten the heat sink and regulator to the PC board so that the following sequence results from bottom to top: 6-32 machine screw head, PC board, heat sink, regulator, lock washer, and nut. Tighten the machine screw. Now solder the regulator leads.

NOTE: Heat sink grease may be used though it is not generally needed. Don't tighten the machine screw too tight or you will crack the PC board.

- A9. Install the 12 volt 78L12 regulator (Q3) near location 2B, orienting the regulator so that the flat edge corresponds to the flat edge indicated on the layout legend.
- A10. Install and solder the 34-pin cable connector header (J2). The right angle bent pins should be inserted into the PC board and the straight ends of the pins should be pointing toward the top of the board.
- A11. Be sure the power is off and then plug the disk controller board into a computer motherboard 100-pin connector. Be sure the board is properly seated in the connector and then turn on the power. Check for +5 volts $\pm 5\%$ (with reference to the ground plane at the left of the board) at 3C pin 16 and at 2C pin 14. Check for +12 volts $\pm 5\%$ at location 1A at pin 7 of both the LF356 and the 3080. Turn off the power and remove the disk controller from the motherboard.

If the voltage was not as indicated, locate and correct the problem before going on.

- A12. Install all 47 IC's in the locations indicated on the layout legend, being careful to use the correct orientation. All the IC's should be oriented the same way, with pin 1 toward the bottom. Be sure all the IC pins are in the socket holes and not bent under the IC and not outside the socket.

The three PROM's can be identified as follows:

Layout Name	Location	PROM Type	PROM Label
DWE	4C	6301	DWE-y
DSEL	11C	6301	DSEL-xx-y
DPGM	9D	6309	DPGM-xx-y

xx=two high order HEX digits of PROM origin
y =version number

The labels on the PROM's for the standard version #1 are DWE-1, DSEL-E8-1, and DPGM-E8-1.

The disk controller board is now completely assembled. Proceed to the checkout section.

DISK CONTROLLER BOARD CHECKOUT

The following checkout procedure may be followed for a newly assembled board. However, you may choose to skip this section and return to it later only if the disk controller does not seem to be operating correctly. It can also be used to diagnose problems in previously operational boards.

The following terms are used in specifying expected test results:

GND	ground, 0 volts DC
LOW	logic zero, 0-.7 volts, normally about 3 volts
HIGH	logic one, 2.4-5.0 volts, normally about 3 volts
+5V	+5 volts from power supply
AC	Signal with pulses (as opposed to DC signal)

When referring to the name of a signal from the schematic drawings, if the signal is identified with a bar over its name, then the name is followed by a slash (e.g., STORE/) in the checkout instructions. When describing an AC pulse, the notation ($\pm W, P$) refers to a positive or negative pulse with a width of W appearing with a period of P . For example, a positive pulse with width 120 nanoseconds appearing every 25 microseconds would be described as (+120ns,25us). See Appendix 1 for details on how to detect pulse signals.

If an oscilloscope will be used to test the board, a "scope ground" may be installed by soldering a "bridge" of jumper wire between the two PC board holes that connect edge connector pins 50 and 100 near location 12D. Note that either of the two regulator machine screws can also be used for ground test points.

C1. With the computer power off, install only the disk controller board into the motherboard. The ribbon cable should not be plugged into the board. Turn on the computer power and check for the following counter timing signals:

SIGNAL	LOCATION	DESCRIPTION
LCLK/	15B pin 12	AC, 500ns square wave
CC3	6A pin 11	AC, 8.us square wave
CC6	7A pin 11	AC, 128us square wave (some jitter)
CC11	8A pin 11	AC, 2ms square wave (some jitter)
CC15	9A pin 11	AC, 32ms square wave (some jitter)
SC03	15C pin 6	AC, 500ms square wave
(no name)	3D pin 6	AC, 8.3sec square wave
AUTO-OFF	6C pin 11	AC, (+8.3sec,33sec)

If the signals are not as listed then refer to the schematic drawings and trace backwards to locate and correct the problem.

- C2. This step will check the write circuitry while simulating writing a continuous stream of "one" data bits in single-density format during each sector.
- A. With the computer power off, remove the disk controller board from the motherboard.
 - B. Remove the 74LS74 IC from location 14C, bend out pin 9 of the IC, and re-insert the IC so that pin 9 is outside the IC socket and does not make contact with IC socket pin 9.
 - C. Connect a clip lead between cable connector (J2) pin 22 and pin 30. If you do not have a clip lead, then tack solder a wire on the solder side of the board between 13B pin 11 and 14B pin 13.
 - D. With the computer power off, install only the disk controller board and the processor board into the motherboard, and turn the computer power on.
 - E. Check the following signals while the computer reset switch is depressed (hold depressed with a rubber band):

SIGNAL	LOCATION	DESCRIPTION
WR-SHIFT/ LD-WSR/	6D pin 6	AC, (-1us,8us)
WS7	6D pin 15	AC, (-8us,64us)
WS10	6D pin 13	AC, (-96us,32ms) i.e. mostly HIGH
WRITE PULSE	5C pin 15	AC, (-96us,32ms) i.e. mostly HIGH
(no name)	3C pin 5	AC, (+approx 600-700ns,4us)
READ DATA	3C pin 13	AC, (+approx 600-700ns,4us)
	14B pin 12	AC, (+approx 600-700ns,4us)

If the signals are not as listed then refer to the schematic drawings and trace backwards to locate and correct the problem.

- C3. This step will check the read circuitry while simulating reading a continuous stream of zero" data bits in double-density format during each sector. If using a scope to check signals then sync positive on 13C pin 9. Continue with the same setup as in the previous step. Check the following signals while the computer reset switch is depressed.

SIGNAL	LOCATION	DESCRIPTION
WINDOW	13C pin 9	"Window", HIGH for 96us then LOW
RE	5B pin 6	"Read Enable", goes HIGH at 480us
ACQUIRE	5A pin 5	"Acquire Phase of Incoming Signal", goes HIGH with RE, duration 100-150US

2BR	3B pin 5	"Twice Bit Rate", low at first, 4us square wave for 32us when RE goes high, then 2us square wave
DDI	4B pin 9	"Double-Density Indicator", goes HIGH at 512us (32us after RE)
HE	14C pin 5	"Hunt Enable", goes HIGH at 7361
OP-AMP-OUTPUT	Right side R7	See Note 1.
DATA WINDOW	4D pin 5	May begin either HIGH or LOW, then 4us square waves after RE
WIND DATA	4D pin 9	"Separated Data", always LOW except for 8 extremely narrow pulses at ACQUIRE
RSn	15D pins 3,4,5, 6,10,11,12,13	"Read Shift Register", all outputs always LOW
BODY	5B pin 10	LOW

Note 1: Initializes during WINDOW by slewing to +5 volts. During ACQUIRE there will be numerous small positive or negative pulses (phase corrections). A DC shift of less than 1/4 volt may be seen at this time if a frequency adjustment occurs. The resultant DC level should remain until the next WINDOW pulse.

Note 2: The two op-amp (LF356) inputs are very high impedance and attempts to observe them with a scope probe can affect the circuit.

- A. Remove the 74LS74 IC at location 4D, lift pin 9 of the IC, and re-insert the IC so that pin 9 is not inserted in the IC socket. Then, with the computer reset switch depressed, check of the following signals:

SIGNAL	LOCATION	DESCRIPTION
BODY	5B pin 10	Goes HIGH at 780us
SYNC BLANK	1B pin 13	pulse beginning at 780us, duration 38-50us

- B. Re-insert the pins of the IC's at locations 14C and 4D into their IC sockets and remove the clip lead or soldered wire.

DISK CONTROLLER CONFIGURATION OPTIONS

There are a number of configuration options possible on the disk controller board that are specified by wiring jumpers on the board. The desired configuration should be wired according to the following instructions before the board is used.

- J1. Signal grounding. The "G" jumper below location 5D is normally installed when the disk controller is used in a HORIZON. If the disk controller is to be used in another S-100 bus computer, then the "G" jumper should be installed only if motherboard signal 61 is used as ground in that computer.
- J2. Automatic motor off time. Normally, the disk drive motor(s) will turn off 9.6 seconds after the last disk activity. If some other automatic motor off delay time is desired, then cut the traces at location 2D on the solder side of the PC board which connect "C" to "2" and "D" to "1". Then connect two jumper wires on the component side of the PC board at location 2D according to the following table:

DELAY TIME	FIRST JUMPER	SECOND JUMPER
3.2 seconds	Connect D to 3	Connect 2 to 1
6.4 seconds	Connect C to 3	Connect 2 to 1
9.6 seconds	Connect C to 2	Connect D to 1
12.8 seconds	Connect B to 3	Connect 2 to 1
16.0 seconds	Connect B to 2	Connect D to 1
19.2 seconds	Connect B to 2	Connect C to 1
25.6 seconds	Connect A to 3	Connect 2 to 1
28.8 seconds	Connect A to 2	Connect D to 1
32.0 seconds	Connect A to 2	Connect C to 1
38.4 seconds	Connect A to 2	Connect B to 1

- J3. Sector Interrupts. The disk controller board includes logic which can cause an interrupt to occur each time a sector hole is detected on a diskette. Normally, this logic is disabled. To use this logic, first cut the two traces on the solder side of the PC board near locations 10A and 10B which connect "J" to "K" and "J" to "E". Second, install two jumper wires on the component side of the PC board which connect "S" to "J" and "I" to "K". Third, cut the trace below location 4D on the solder side of the PC board that connects "Y" to "PH/". Finally, connect a jumper wire below location 4D on the component side of the PC board which connects "Y" to the position for the type of interrupt desired (VI0/ to PINT/).

POWER BOARD ASSEMBLY

There are three different ways that power can be supplied to a disk drive.

- a. Direct hook-up of regulated +5 volts and +12 volts from an existing regulated power supply. In this case the Power PC Board is not used and the four conductor power cable should be connected directly to the power plug as described in Step P5 below. The other end of the power cable should be connected to the corresponding outputs of the regulating power supply.
- b. Use the Power PC Board to regulate power from an existing unregulated power supply. The power supply in many S-100 bus computers is adequate to power one drive. In general, compare the disk drive power requirements against the power supply capacity to see if this arrangement will work. If this power supply option is to be used then follow the instructions below starting at Step P1.
- c. Use the North Star Power Supply option (MDS-PS). The MDS-PS provides all the components needed to obtain unregulated power from a 115 volt AC line. Some of the MDS-PS parts mount on the Power PC Board and some mount to the North Star MICRO-DISK Cabinet (MDS-CAB) or elsewhere. If this option is used then start assembly with Step P1 below and continue with the MDS-PS assembly instructions.

The silk screen legend is on the component side of the PC board and the traces are on the solder side.

- P1. Bolt the +5 volt regulator (7805 or 340T-5) to the inside of the 6030B heat sink so that the following sequence results from top to bottom: 6-32 machine screw head, heat sink, regulator, lock washer, and nut. The regulator leads should point the same direction as the heat sink mounting posts.
- P2. Install the regulator heat sink assembly by inserting the regulator leads in the correct holes on the PC board and then inserting the heat sink mounting posts in their holes. Now solder the regulator leads.
- P3. Mount the 690-3-B heat sink and 7812 regulator on the PC board such that the following sequence results from back to front: 6-32 machine screw heads, PC board, heat sink, regulator, lock washers, and nuts. Two machine screws are required to mount this regulator. Position the heat sink as far from the edges of the PC board as possible and tighten the machine screws. Now solder the two regulator leads.
- P4. Assemble the disk drive power plug as follows. Cut off a piece of 4-conductor power cable about 3 inches long. Remove an inch of outer insulation from both ends. Strip

1/4" of insulation from each conductor at both ends. Crimp and solder each of the four power plug pins to the conductors at one end. Finally, insert the power plug pins into the power plug using the following color code: +5 red, +12 green, ground black and white. Consult the OEM Manual (sections 4.2 and 5.2) for the correct connection of power to the power pins.

- P5. Solder the four wires coming from the power plug assembly to the appropriately labeled holes in the lower righthand corner of the PC board. The wires should be inserted into the PC board from the solder side.

NOTE: If the MDS-PS power supply is being used, then skip the remaining steps of these instructions and go on to the MDS-PS assembly instructions.

- P6. Insert and solder the two .047uf ceramic disc capacitors (C1 and C2) in the locations indicated by the silk screen legend.
- P7. The four wires in the 5-foot power cable should be soldered to the four holes in the PC board labeled 0v, 0v, 9v, and 18v using the following color code: 0v black, 0v white, 9v red, 18v green. The wires should be inserted into the PC board from the component side.
- P8. Connect the other end of the power cable to the appropriate power points of the unregulated power supply. For example, the cable can be connected to the power pins at an unused position on the S-100 bus mother board. Consult the computer reference manual for details. If the disk drive is to be mounted inside a cabinet (MDS-CAB) then the power cable should be passed through a hole in the back of the cabinet and clamped with the provided strain relief bushing before connection to the power source.
- P9. Check that the regulators are providing +5 and +12 volts at the proper power plug pins before plugging into the drive.
- P10. Mount the PC board to the back of the disk drive as follows. Carefully remove the two machine screws that mount the small PC board to the back of the disk drive. Save the quick-connect lug and lock washer from the righthand (as seen from the back of the disk drive) mounting screw. Use the two longer machine screws and spacers so that the following sequence results from back to front: machine screw head, (quick-connect lug and lock washer on righthand screw only), power PC board, longer spacer, small PC board, shorter spacer, and disk drive. The power PC board should be mounted with the solder side toward the drive.

The power board is now ready to use.

POWER SUPPLY (MDS-PS) ASSEMBLY

Start by assembling the power PC board following steps P1-P5. If the board is being converted from use with an unregulated power source then the two capacitors C1 and C2 should be removed. Then continue with the following steps.

- S1. Install and solder the two electrolytic capacitors in the locations indicated by the silk screen legend. Be sure to mount both capacitors with the "+" side oriented as indicated by the silk screen legend.

C3	3500uf	15wvdc	electrolytic
C4	3000uf	30wvdc	electrolytic

- S2. Install and solder the four rectifier diodes. Be sure to observe the correct polarity when installing the diodes. The banded end of the diode should correspond to the band marked on the silk screen legend.

D1	MR501	3 Amp	D3	1N4002	1 Amp
D2	MR501	3 Amp	D4	1N4002	1 Amp

- S3. Mount the transformer to the cabinet using the 6-32x1/2" machine screws such that the following sequence results from bottom to top: machine screw head, cabinet, transformer, lock washer, and nut. The transformer should be mounted so that the solder lugs are away from the back of the cabinet.
- S4. Mount the toggle switch in the leftmost hole (looking from the back) and the fuse holder in the center hole.
- S5. Pass the power cord through the rightmost hole and solder one wire to lug 1 of the transformer. Cut the other wire shorter and solder it to the lug at the end of the fuse holder. Clamp the power cord to the cabinet using the strain relief bushing.
- S6. Solder the other lug of the fuse holder to one of the lugs of the toggle switch with a short piece of hook-up wire and then solder the other lug of the toggle switch to lug 2 of the transformer.
- S7. Put the fuse in the fuse holder.
- S8. Solder the three transformer lugs 3, 4, and 5 to the three corresponding holes in the power PC board marked T3, T4, and T5 on the silk screen legend using short pieces of hook-up wire (about 4 or 5 inches).

Now follow steps P9 and P10 of the Power Board assembly instructions and the power supply is ready to use.

SYSTEM INTEGRATION

Before using the MICRO-DISK System the various components must be configured and integrated with each other.

DISK DRIVE CONFIGURATION

If the MDS is to be configured with only one disk drive connected to the controller then no modification is required for the disk drive. If two or more drives are to be connected to the controller then the following disk drive modifications must be made.

- A. The drive number for each drive must be programmed using the program shunt (located at 1F) on the disk drive PC board. The three metal straps labeled DS1, DS2, and DS3 specify whether the drive is to be selected as drive 1, 2, or 3, respectively. For each drive, the strap for the desired drive number should remain connected and the other two straps should be disconnected. Straps can be disconnected by removing the strap assembly from the DIP socket, spreading one of the pins for each undesired strap and plugging the assembly back in such that the spread pins are not inserted into the DIP socket. Each drive should be programmed with a different drive number. One drive must be number one.

To program a drive as drive number 4 perform the following instructions on the printed circuit board mounted on top of the disk drive.

- a. Solder a jumper wire between pin 34 of edge connector J1 and location 1F pin 6. Take great care to connect the wire to the very tip of pin 34 so that the ribbon cable connector can slip as far onto J1 as possible.
 - b. Solder a jumper wire between 1F pin 9 and 1F pin 11.
 - c. The unmarked strap location between MX and MH at location 1F is now the location for programming drive 4. It can be labeled DS4. This strap should remain connected and the straps labeled DS1, DS2, and DS3 should be disconnected. Be sure to disconnect this strap if the drive is ever programmed to be drive 1, 2, or 3.
- B. The strap labeled MX on the program shunt (located at 1F) should be disconnected. Be sure that the HL strap (alternatively labeled HS on some drives) remains connected and the MH strap remains disconnected.
 - C. Five pull-up resistors for line termination on the ribbon cable are located in the DIP resistor network at position 1E. Only the drive plugged in at the end of the ribbon cable should have this resistor package plugged in. Additional drives plugged in along the cable should have the resistor package removed.

CABLE CONFIGURATION

The ribbon cable assembly supplied with the MICRO-DISK System is ready to use with a one disk drive system. An additional edge connector plug must be crimped onto the cable for each additional drive. Be sure these plugs point the same way as the edge connector plug at the end of the cable (and opposite to the controller board plug). The spacing of the plugs along the ribbon cable should be determined by the desired physical positions of the disk drives. With the component side of the controller board facing toward you, the ribbon cable should be plugged into the controller board so that the cable extends away from you. If the cable comes out of the plug toward you then it is plugged in wrong. The drive edge connector plugs should be plugged into position J1 on the drive PC board such that the cable going toward the controller runs out the bottom of the plug. The cable should be routed around the power PC board by making a flat 90 degree fold in the cable immediately below the edge connector plug. Some tape should be applied to the back of the power PC board to avoid abrasion of the ribbon cable where it touches the power PC board. Note that cable connection shown in the disk drive OEM manual is NOT correct for use in a North Star system.

CHASSIS GROUNDING

For most reliable operation of the integrated disk system, a ground wire must be installed between the chassis of the disk drive and the chassis of the computer. A separate ground wire should be installed for each disk drive in the system. To install a chassis ground wire, first fasten the supplied quick-connect lug under a convenient screw on the computer chassis. Then slip one end of the supplied wire onto the quick-connect lug on the power regulation board mounting screw, and slip the other end of the wire onto the quick-connect lug on the computer chassis.

NAME PLATE MOUNTING

For each disk drive in the system, peel the paper from the back of the North Star name plate and carefully mount the name plate to the face plate of the disk drive.

CABINET ASSEMBLY

- B1. Mount the four rubber stick-on feet at the four corners of the bottom of the cabinet.
- B2. Mount the disk drive (with power PC board if required) to the bottom plate of the cabinet with the four flat head screws. The MDS-PS power supply, if used, should be mounted into the cabinet.
- B3. The cabinet cover is secured with six pan head 6-32 screws, two on each side and two in the back.

INTEGRATED SYSTEM CHECK-OUT

All components of the system should now be assembled and ready to be put together. This section describes a step-by-step process for integrating the MDS into your computer in a way designed to localize any remaining problems. It is assumed that the computer, into which the MDS is being installed, is already a working system.

- I1. Turn off the computer power if it is on and plug the MDS controller board into the computer and connect the ribbon cable between the controller and disk drives as directed in the Cable Configuration section.
- I2. Turn on the power and check that the power at the drive power plug is +5 and +12 at the proper pins. Then turn off the power and plug the power plug into connector J2 on the drive PC board.
- I3. Turn on the computer and disk drive power and cause the computer to jump to address E800(hex). (This address will be different if PROMs with non-standard origins are used.) The disk drive motor(s) should turn on and the red light on drive #1 should turn on. Then the motor(s) should turn off after twelve seconds. If the motor(s) do start, then proceed to step I4. Otherwise, if the motor(s) do not turn on, continue this step as follows:
 - A. Momentarily ground 12B pin 1 on the disk controller board by briefly shorting it to 12B pin 7 with a piece of jumper wire. If this causes the motor(s) to turn on, then remove the wire and proceed to part B. If this does not cause the motor(s) to turn on, then check the signal cable connections to the disk drive and the power Cable connections to the disk drive. After locating and correcting the problem, start over at the beginning of step I3.
 - B. Momentarily ground 13C pin 1 (MOTOR SET/) by briefly shorting it to 13C pin 8 with a piece of jumper wire. The

motor(s) should turn on and then stay on for about 12 seconds after the wire is removed. If this succeeds, then proceed to part C. If this does not succeed, then the problem is with the counting circuitry on the disk controller board. After locating and correcting the problem, start over at step I3.

C. Turn off the power and remove the 74LS00 from location 7C. Remove the 74LS08 from location 6C, bend pin 3 of the IC out and re-install the IC into the IC socket so that pin 3 of the IC does not make contact with pin 3 of the IC socket. Turn on the computer and drive power and ground motherboard pin 43 by shorting it to motherboard pin 50 with a piece of jumper wire. This experiment will force the processor to sequentially read every address in the computer continuously, including the memory-mapped I/O locations that turn on the drive motor(s) and select the drive(s). If the motor(s) do not turn on, then trace backwards from the signal MOTOR-SET/ to find out why. After correcting the problem, remove the jumper, replace the IC's correctly at locations 7C and 6C, and start over at the beginning of step I3. If the motor(s) do come on, that indicates that the problem detected at the beginning of this step is a result of the PROM program not being correctly executed. Remove the jumper, replace the IC's, and proceed to part D.

D. Turn off the power and ground PRDY on the disk controller board by shorting 11A pin 7 to 11A pin 8. Turn on the computer and drive power and cause the computer to jump to address E800(hex). The processor should pause just before executing the first instruction of the disk controller PROM. The S-100 address bus A0-A15 (see the ZPB Manual Appendix 2 for bus pin numbers) should contain E800H. (If this is not so, then the problem is elsewhere in the computer.) The S-100 data input bus D10-D17 (see the ZPB Manual Appendix 2 for pin numbers) should contain 0EH which is the first instruction byte in the PROM. If this is not so, then the problem is with the PROM circuitry on the disk controller board. Trace backwards through this logic to isolate the problem. After correcting the problem, remove the jumper and start over at the beginning of step I3.

I4. Next, turn on the computer and drive power with no diskette in drive #1 and cause the computer to jump to address E800(hex). Approximately 12 seconds after the drive is selected and the heads load, the motor(s) will turn off. The processor at this point should be executing a tight JMP loop indicating a read error. This can be checked by observing a continuous stream of pulses on the disk controller board at 7C pin 6 (DI-GATE/).

I5. Check that the head carriage guide on the disk drive is in the spiral groove on the stepper motor cam. Sometimes the

guide is knocked out of the groove during shipment.

- I6. Turn on the computer and drive power, and insert the software diskette supplied with the system into drive #1, referring to the GETTING STARTED Section of the North Star System Software Manual for correct diskette handling procedures. Close the drive door and cause the computer to jump to address E800(hex). One of two results will occur:
 - A. The bootstrap program goes into the error loop as described in step I4. This indicates trouble reading the data from the diskette which can mean a bad diskette, a faulty disk drive, or faulty read circuitry on the disk controller. Return to the disk controller checkout instructions.
 - B. The bootstrap program successfully loads the DOS. Since the diskette supplied with the disk system is unpersonalized, communication with your console terminal will not occur. Instead the DOS will be executing a tight JMP loop but no pulses will be observed on the DI-GATE/ signal. Congratulations! Your Micro Disk System is now completely assembled and operational. The next step is to refer to the GETTING STARTED section of the North Star System Software Manual for complete details of how to use the software provided with the Micro Disk System.

THEORY OF OPERATION

The North Star double density disk controller is an integrated combination of hardware and software. It is designed specifically to provide a complete, compact and economical disk drive controller for use with S-100 bus 8080 or Z80 microcomputer systems.

DISK CONTROLLER HARDWARE

The disk controller is implemented from medium and small scale TTL integrated circuits and PROM memory. The entire controller fits on a single 5"x10" printed circuit card. The block diagram below shows the general organization of the disk controller.

1. Address Buffers and Select Logic: The sixteen address/lines are received with Schmitt trigger buffers (7D, 10D, 11D) to provide noise immunity. The high order 8 address lines are used by the board select PROM (DSEL, 11C) to determine if the current memory reference is addressing the controller board. The low order eight address lines are used to present data and control information to the controller. The use of these bits is determined by the outputs of the board select PROM.
2. Write Data Logic: If the controller is issued a write data byte command, then the low order eight address bits are interpreted as data to write and are gated into the write shift register (6D). The controller will place the CPU in a wait state until the shift register is empty and only then clock the new data into the shift register. Write encoding (using the FM encoding method for single density and MFM encoding for double density) and write precompensation are controlled by the logic at locations 3C, 4C, and part of 5C.
3. Read Data Logic: Raw data from the disk is standardized by the RD-DAT-OS one-shot (5A). A phase-locked loop (1A, 4A, and parts of 1B, 5A) tracks the trailing edge of RD-DAT-OS to match the frequency of the incoming data. The phase-locked loop output drives the data separator (3B, 4D), whose outputs, DATA-WINDOW (clock) and WIND-DATA (data), go to the 8-bit read data shift register (15D). The read shift register outputs are multiplexed with the status bits (12D, 13D, 14D) and driven onto the Data Input Bus (10D, 11D). When reading, if double density data is encountered, the double density indicator (DDI,4B) is set.

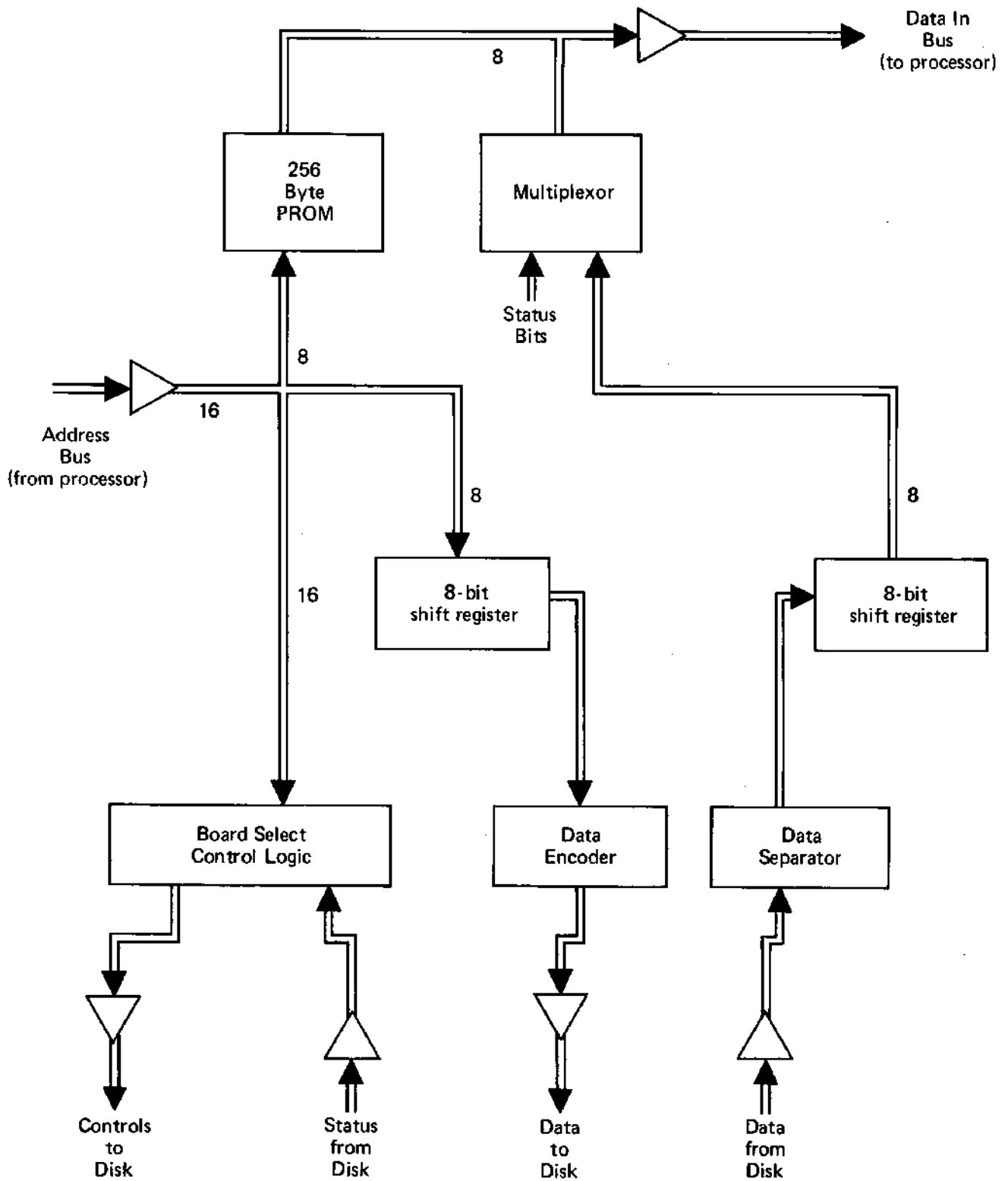

Figure 1T. Disk Controller Block Diagram

4. On Board PROM: Bootstrap software (8080/Z80 machine code) is stored in an on-board 256 byte bipolar PROM (DPGM, 9D). This PROM provides 256 bytes of memory: The 8 low order address bits address the PROMs. The PROM outputs are driven onto the Data Input Bus.
5. Clock Circuit: The crystal clock oscillator circuit (15B) provides 2 MHz clock signals to synchronize the control circuitry.
6. Read, Write Control: A read or write command sequence begins with detection of a sector pulse. A read or write command must be issued to the controller within a 96 microsecond window after the sector pulse. Writing data begins at the end of the window. The controller writes one byte of zeros. Writing of subsequent data is controlled by the software. Writing stops at the next sector pulse. Reading starts some time after the end of the window so as to be in the middle of the written preamble. First the phase-locked loop is turned on by the read enable (RE) signal. After locking to the incoming data is achieved, the hunt enable (HE) signal causes the search for a sync character to begin. When a sync character is detected, the controller enters "body" mode. When the software issues a read command to the controller, the controller will put the CPU into the wait state until the read shift register is full.
7. Command Decode Logic: When a command address is issued to the controller, the 8 low order address bits are decoded to determine which command actions are to be taken and which disk controls should be performed. See the Disk Controller Commands section for details.
8. Counters: The counters (6A, 7A, 3A, 9A) provide sector timing and read and write command sequencing. The counter (15C) is the sector position counter. The output of 9A provides pseudo sector pulses in case no diskette is inserted in the drive or the drive motor is off and also allows discrimination between sector holes and the index hole. The counter (3D) is used to count disk revolutions to determine when to cause automatic motor off. The counters (9B) are used to count bits while reading or writing data.

DISK CONTROLLER COMMANDS

Commands to the disk controller are specified by memory read references to addresses within a particular 1K byte block of the CPU address space. The 1K byte block subdivides into four cases. In all cases the high order 6 address bits (BS) are used to determine if the 1K block is addressed (i.e. the controller board is selected). The next two bits determine the subcase and the use of the low order eight bits depends on the subcase.

CASE 0 PROM addressing



Read byte from the 256 bytes of PROM.

CASE 1 Write byte of data



Write a byte of data to the disk. Wait if the write shift register is not empty. The low order 8 bits specify the byte to be written.

CASE 2 Controller Orders

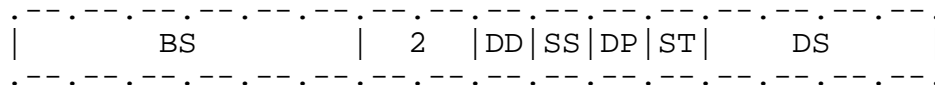

Load 8-bit order register from low order 8 address bits.

DD Controls density on write DD=1 for double density and DD=0 for single density.

SS Specifies the side of a double-sided diskette. The bottom side (and only side of a single-sided diskette) is selected when SS=0. The second (top) side is selected when SS=1.

DP has shared use. During stepping operations, DP=0 specifies a step out and DP=1 specifies a step in. During write operations, write procompensation is invoked if and only if DP=1.

ST controls the level of the head step signal to the disk drives.

DS is the drive select field, encoded as follows

0=no drive selected
 1=drive 1 selected
 2=drive 2 selected
 4=drive 3 selected
 8=drive 4 selected

CASE 3 Controller COmmands

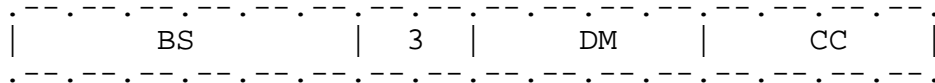

Perform a disk controller command. The commands are specified by the 8 low order address bits.

DM The DM field controls what gets multiplexed onto the DI bus during the command.

1=A-status
 2=B-status
 3=C-status
 4=Read data (may enter wait state)

CC Command code.

0=no operation
 1=reset sector flag
 2=disarm interrupt
 3=arm interrupt
 4=set body (diagnostic)
 5=turn on drive motors
 6=begin write
 7=reset controller, de-select drives, stop motor

DISK CONTROLLER STATUS BYTES

There are three status bytes that can be read on the Data Input Bus.

A-Status



B-status

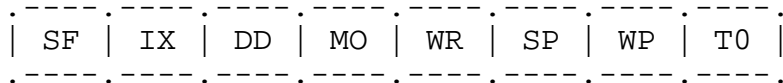

C-Status

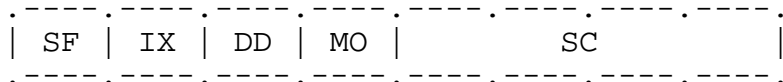

- SF Sector Flag: set when sector hole detected, reset by software.
- IX Index Detect: true if index hole detected during previous sector.
- DD Double Density Indicator: true if data being read is encoded in double density.
- MO Motor On: true while motor(s) are on.
- WI Window: true during 96-microsecond window at beginning of sector.
- RE Read Enable: true while phase-locked loop is enabled.
- BD Body: set when sync character is detected.
- WR Write: true during valid write operation.
- SP Spare: reserved for future use.
- WP Write Protect: true while the diskette installed in the selected drive is write protected.
- SC Sector Counter: indicates the current sector position.
- T0 Track 0: true if selected drive is at sector zero.

DISK CONTROLLER DATA FORMAT

Each diskette has 35 tracks of data. Each track is divided into 10 sectors. The rotational position of the beginning of the sectors is marked by sector holes in the diskette. Each sector is recorded using the following format. This information is recorded starting about 96 microseconds after the sector hole is detected.

	Single Density	Double Density
Zeros	16 bytes	32 bytes
Sync Char(FB)	1 byte	2 bytes
Data	256 bytes	512 bytes
Check Char	1 byte	1 byte
---	---	---
	274 bytes	547 bytes

The check character is computed iteratively by setting it to zero and then exclusive ORing each successive data byte value with the current value of the check character and left cycling the result.

DISK CONTROLLER SOFTWARE

The basic low-level function of the controller is to transfer or verify 256/512 byte blocks of data between a specified area on the disk and a specified area of the RAM. The algorithm now described accomplishes this task. The program to perform this algorithm resides in the DOS.

1. Start the drive motor(s) if they were off and wait for the motor to get up to speed.
2. If the disk drive to be selected is different than the drive currently selected or if the motor(s) were off then select the new drive, and wait for the index detect signal to be true.
3. If the disk read/write heads are not already at the desired track then the heads must be stepped in or out to the correct track. First set the step direction flip-flop and determine the number of tracks to step. Each step is accomplished by the following sequence:
 - a. set the step flip-flop
 - b. reset the step flip-flop
 - c. wait the specified track stepping time.
4. Wait until the next sector pulse and test if the disk is at the desired sector position by reading C-status. If not then repeat this step.

5. If the data write case then
 - a. issue begin write command.
 - b. wait for WI status bit to be false.
 - c. write 15/31 bytes of zeros.
 - d. write the sync character(s) (FB hex).
 - e. write 256/512 bytes of data from RAM while computing the cyclic check character.
 - f. write the check character.
 - g. if more blocks to write on the same track then wait until the next sector pulse and repeat from step a, otherwise done.

6. If read case then
 - a. wait for RE to be true and test DD status bit.
 - b. wait for sync character detection (i.e. body mode). Report an error if the sync character is not detected.
 - c. read 256/512 data bytes into RAM while computing the check character.
 - d. read the check character and compare with the computed check character. Report an error if they are not equal.
 - e. if there are more blocks to read on the same track then wait until the next sector pulse and repeat from step a, otherwise done.

7. If verify case then all is the same as the read case except that in step c data bytes read from the disk should be compared for equality with the data in RAM. Report an error if corresponding bytes do not compare.

DISK CONTROLLER INTERRUPTS

The software provided with the disk system is not interrupt driven. The controller can cause an interrupt on any one of the interrupt lines on the S-100 bus by connecting the appropriate jumper at the lower left corner of the controller board. An interrupt will be generated at every sector pulse while the interrupt is armed in the controller. See the COMMANDS section for details of interrupt arming and disarming. Special user generated, interrupt driven software can be written which uses the controller sector pulse interrupt.

Before the low level controller software is called, interrupts should be disabled. If an interrupt occurs during data transmission then data can be lost as a result of excessive delay in the interrupt routine.

APPENDIX 1. PULSE SIGNAL DETECTION

Some steps in the checkout procedure will require test equipment capable of distinguishing a signal containing pulses from a DC signal. Any one of the following will suffice.

1. Use of an oscilloscope is best since the shape and frequency of the pulses can also be determined.
2. Use a logic probe that detects pulses.
3. If the board is being assembled for use with a HORIZON, then use a counter on the motherboard to divide the frequencies down to the audio range and then play the result through a hi-fi amplifier. To do this, remove the 74LS161 at location 7D on the motherboard. Then attach the test probe wire to jumper 2D pin 16 (this is the input to the divider). Next, take the output of the divider at jumper 10A pin 11 and connect to the AUX input of the audio amplifier. Finally, connect the AUX input ground on the audio amplifier to signal ground on the motherboard. This arrangement will divide high frequency signals by 4096 and thus put the resulting signal in the audible range. Thus a 4 MHz signal will be heard as a tone one octave higher than a 2MHz signal.
4. Construct the "probe" shown in figure 1C on a piece of cardboard or perf-board. This probe converts high frequency signals to DC signals. The voltage of the resulting DC signal will be proportional to the duty factor of the tested waveform.

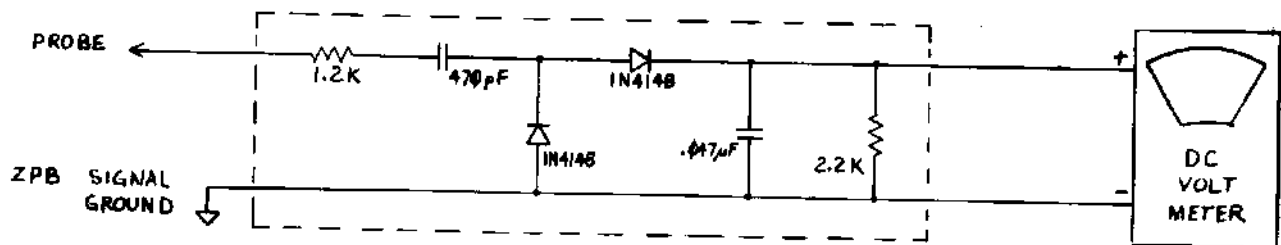
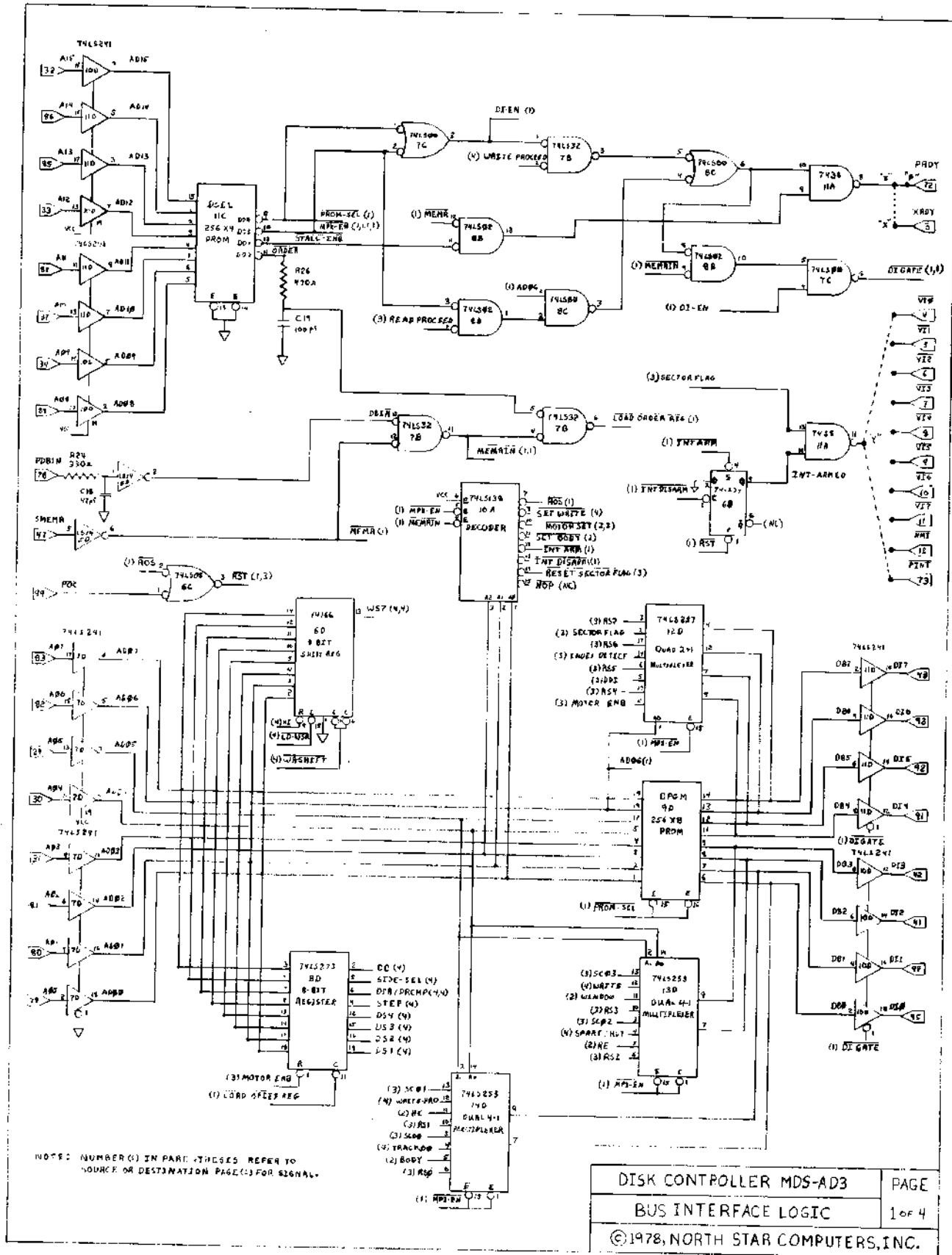
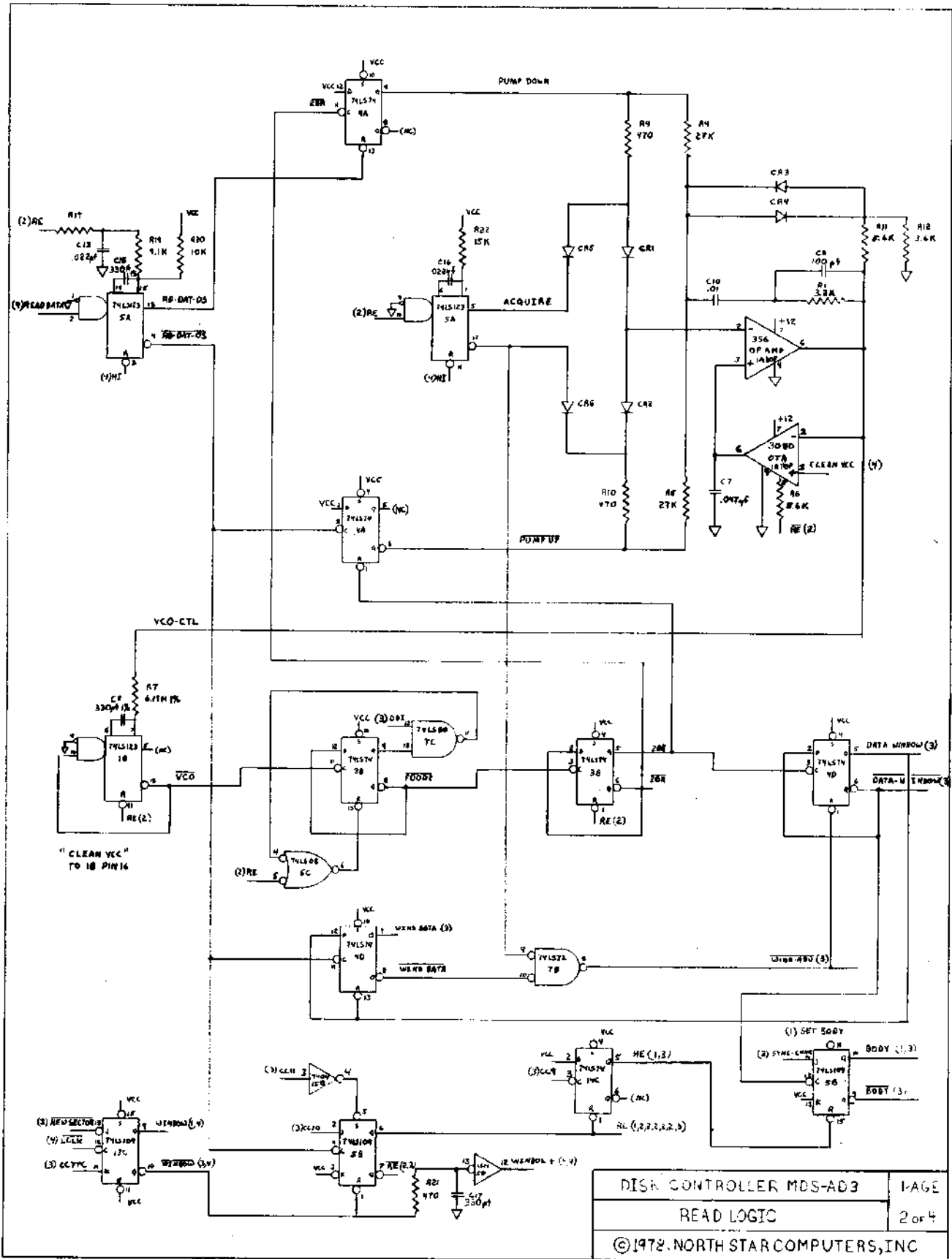
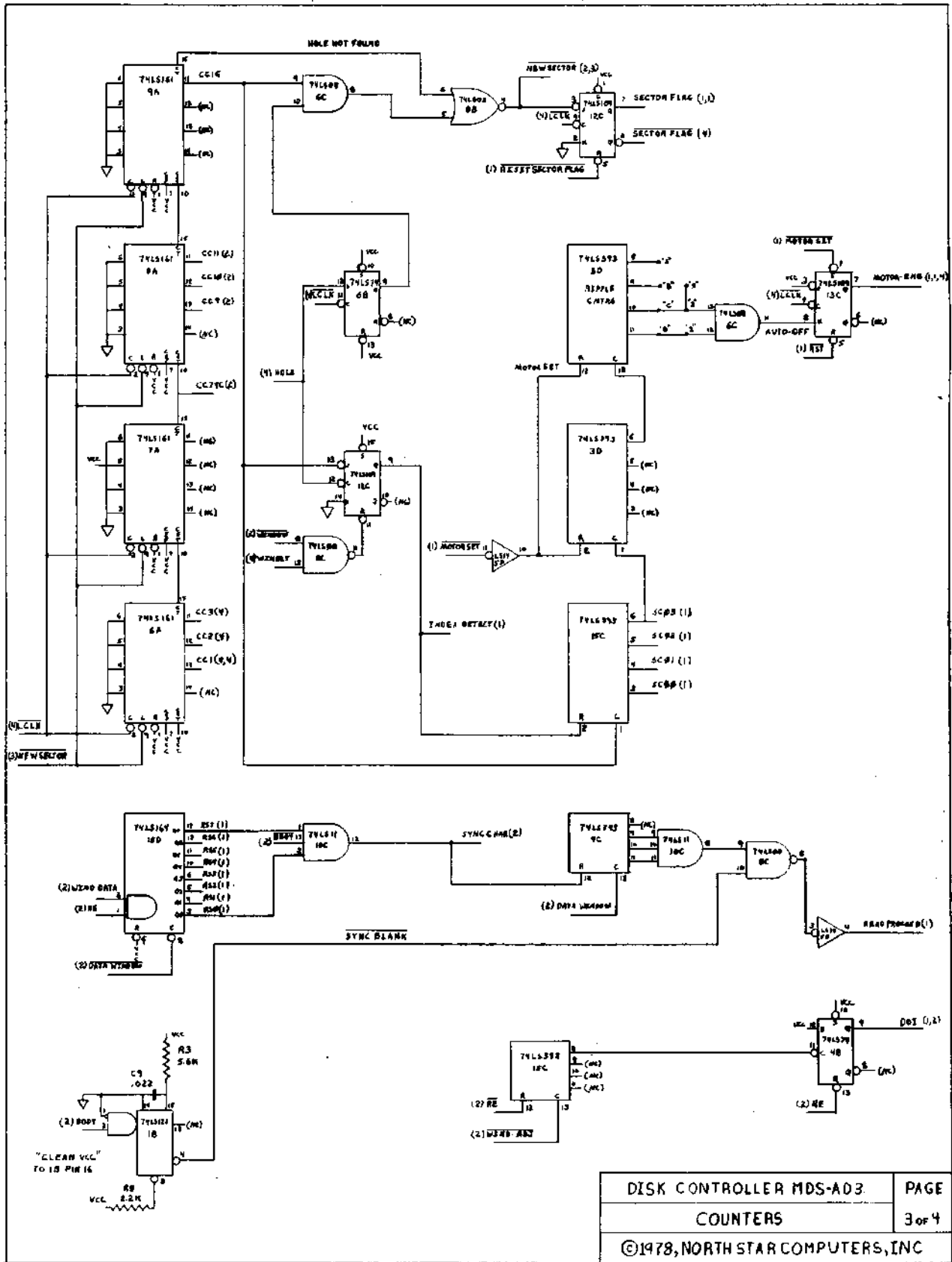

Figure 1C: A.C. SIGNAL DETECTOR







ERRATA AND ADDITIONAL INFORMATION

For: MDS-A-D Manual, Revision 1

JANUARY 16, 1979

1. Interrupts during disk data transfer operations will cause data transfer errors. In systems where interrupts can occur, interrupts can be prevented by disabling interrupts before accessing the disk. The POLY-88 System with the 4.0 monitor causes continuous real time clock interrupts. This interrupt should be disconnected on the processor board to allow proper operation of the disk system.
2. Applying power to a disk drive while the ribbon cable is incorrectly plugged in to either the drive or the controller can DO DAMAGE TO THE DISK DRIVE! It is very important that the instructions given in the CABLE CONFIGURATION section of the MICRO DISK SYSTEM document be followed very carefully. DO NOT follow the instructions in the OEM manual and DO NOT use the pin 1 mark on the ribbon cable plug as an indication of how the plug should be connected.
3. Some MDS-A-D computer kits include non-standard LF356 ICs. The standard North Star part is a plastic, dual in-line package. The non-standard part is in a round metal-can package. Looking down on the top of the round package, the lead which is lined up with the extending metal tab corresponds to pin 8 of the dual-in line IC. To the left of this lead is lead #1, to the right of lead #8 is lead #7. Lead numbering proceeds counterclockwise from lead #1. Note that the substitution part is exactly equivalent to the regular dual in-line IC, with the exception of packaging and lead placement. The leads should be cut and formed so that the part will plug into the bottom half of the IC socket at location 1A.

Please send us feedback about the MICRO-DISK System documentation. We would like to make this documentation as complete, clear, and accurate as possible.