

North Star
MICRO-DISK SYSTEM MDS-A

Contents

Parts List	3
Warranty	6
Theory of Operation	7
Assembly and Check-out	15
System Integration	24
Drawings	27

North Star
MICRO-DISK SYSTEM MDS-A

Contents

Parts List	3
Warranty	6
Theory of Operation	7
Assembly and Check-out	15
System Integration	24
Drawings	27

CAUTIONS

1. Correct this document from the errata before doing anything else.
2. Do NOT insert or remove the MDS controller from the computer while the power is turned on.
3. Do NOT insert or remove IC's from the board while the power is turned on.
4. Be sure the +5 volt regulator is generating +5 volt output voltage before installing any IC's.
5. Be careful to insert all IC's in correct positions and with correct orientation.
6. Do NOT connect or disconnect, mount or dismount, or in any way physically tamper with the disk drive, power board, or disk controller while the power is turned on.
7. In some cases disk drives may not operate properly if located in the vicinity of TV's, electric motors, or other sources of electrical noise. This may be remedied by moving the disk drive away from the noise source or by installing the disk drive in a grounded cabinet.

PARTS LIST

MDS SYSTEM PARTS

1 disk drive, Shugart SA-400
1 ribbon cable assembly
1 diskette, blank
1 diskette, pre-recorded with software
1 MDS manual
1 DOS manual
1 BASIC manual
1 OEM manual
1 MDS controller with parts
1 power board with parts

MDS CONTROLLER PARTS

1 printed circuit board (5" x 10")
1 bolt, 6-32x1/2"
1 lock washer
1 nut, 6-32
1 heat sink, 6101B-14
1 5 volt regulator, 7805 or 340T-5
1 crystal, 4MHz
23 16-pin low profile IC sockets
24 14-pin low profile IC sockets
1 34-pin cable connector header

Integrated Circuits

3	74LS00	1	74LS157
1	74LS02	1	74LS160
2	74LS08	7	74LS161
1	74LS11	1	74LS164
4	74LS14	1	74LS174
1	74LS30	2	74LS257
2	74LS32	1	7404
1	74LS42	2	7438
5	74LS74	1	74166
4	74LS109	2	74367
1	74LS132	3	6301-1 or 74S287

Capacitors

1	100uf electrolytic	C1
1	6.8uf tantalum	C2
1	470pf dipped mica	C3
1	33pf dipped mica	C4
18	.047uf ceramic disc	by-pass

Resistors

2	680 ohm	R1,R2
4	150 ohm	R3,R4,R5,R6
2	2.2 K	R7,R8

MDS POWER BOARD PARTS

1	printed circuit board, 3" x 5 1/2"
1	1% resistor, RN55D 232 ohm
1	1% resistor, RN55D 1.96 K
2	capacitors, .047uf ceramic disc
1	regulator, 7805 or 340T-5
1	regulator, LM317K
1	heat sink, 295-2
1	heat sink, 690-3-B
3	bolts, 6-32x1/2"
3	lock washers
3	nuts, 6-32
1	power plug
4	power plug pins
1	4 conductor power cable, 5 feet
1	strain relief bushing
2	bolts, 6-32x1 1/4"
2	spacers

POWER SUPPLY PARTS (MDS-PS option)

1	115v cord set, 8 feet
1	strain relief bushing
1	fuse holder
1	fuse, 1A 3AG
1	toggle switch
1	transformer
1	capacitor, 3000uf 30wvdc electrolytic
1	capacitor, 2500uf 15wvdc electrolytic
2	rectifier diodes, MR501 3A
2	rectifier diodes, 1N4002 1A
2	bolts, 6-32x1/2"
2	lock washers
2	nuts, 6-32
1	hook-up wire

CABINET PARTS (MDS-CAB option)

1	cabinet base plate
1	cabinet cover
4	stick-on rubber feet
4	6-32 flat head screws
6	6-32 pan head screws

WARRANTY

North Star Computers, Inc. warrants the electrical and mechanical parts and workmanship of this product to be free of defects for a period of:

- a) 90 days from date of purchase, if purchased in kit form, or,
- b) 180 days from date of purchase, if purchased assembled.

If such defects occur, North Star Computers, Inc. will repair the defect at no cost to the purchaser. This warranty does not extend to defects resulting from improper use or assembly by purchaser, nor does it cover transportation to the factory. Also, the warranty is invalid if all instructions included in the accompanying documentation are not carefully followed. Should a unit returned for warranty repair be deemed by North Star Computers, Inc. to be defective due to purchaser's action, then a repair charge not to exceed \$30 without purchaser's consent will be assessed. Any unit or part returned for warranty repair must be accompanied by a copy of the original sales receipt. This warranty is made in lieu of all other warranties, expressed or implied, and is limited to the repair or replacement of the product.

THEORY OF OPERATION

The North Star MICRO-DISK System (MDS) controller is an integrated system of hardware and software. It is designed specifically to provide a complete, compact and economical disk drive controller for use with S-100 bus 8080 or Z80 microcomputer systems.

HARDWARE

The MDS controller is implemented entirely from medium and small scale TTL integrated circuits and PROM memory. The entire controller fits on a single 5"x10" printed circuit card. The following diagram shows the general organization of the MDS controller.

1. Address Buffers and Select Logic. The sixteen address lines are buffered with Schmidt trigger inverters (4G, 5G, 6G) to provide additional noise immunity. The high order 8 address lines are used by the board select PROM (7G) to determine if the current memory reference is addressing the controller board. The low order eight address lines are used to present data and commands to the controller. The use of these bits is determined by the outputs of the board select PROM.
2. Write Data Logic. If the controller is issued a write data byte command, then the low order eight address bits are interpreted as data to write and are gated into the write shift register (3G). The controller will place the CPU in a wait state until the shift register is empty and only then clock the new data into the shift register. The output of the shift register is combined with clock pulses and encoded (using FM encoding method) for output to the disk drives.
3. Read Data Logic. Raw data from the disk (READ DATA/) is buffered with a Schmidt trigger and formed into one clock period pulses (NICE READ DATA) synchronous with the controller clock(LCLK/). The clock and data pulses are separated by the data separation logic (2A and associated gates) and the resulting data bit is saved in a flip-flop, and then it is clocked into the 8 bit shift register(5E). The read shift register outputs are multiplexed with the status bits (2F, 4F, 4E) and driven onto the Data Input Bus (5F, 6F).

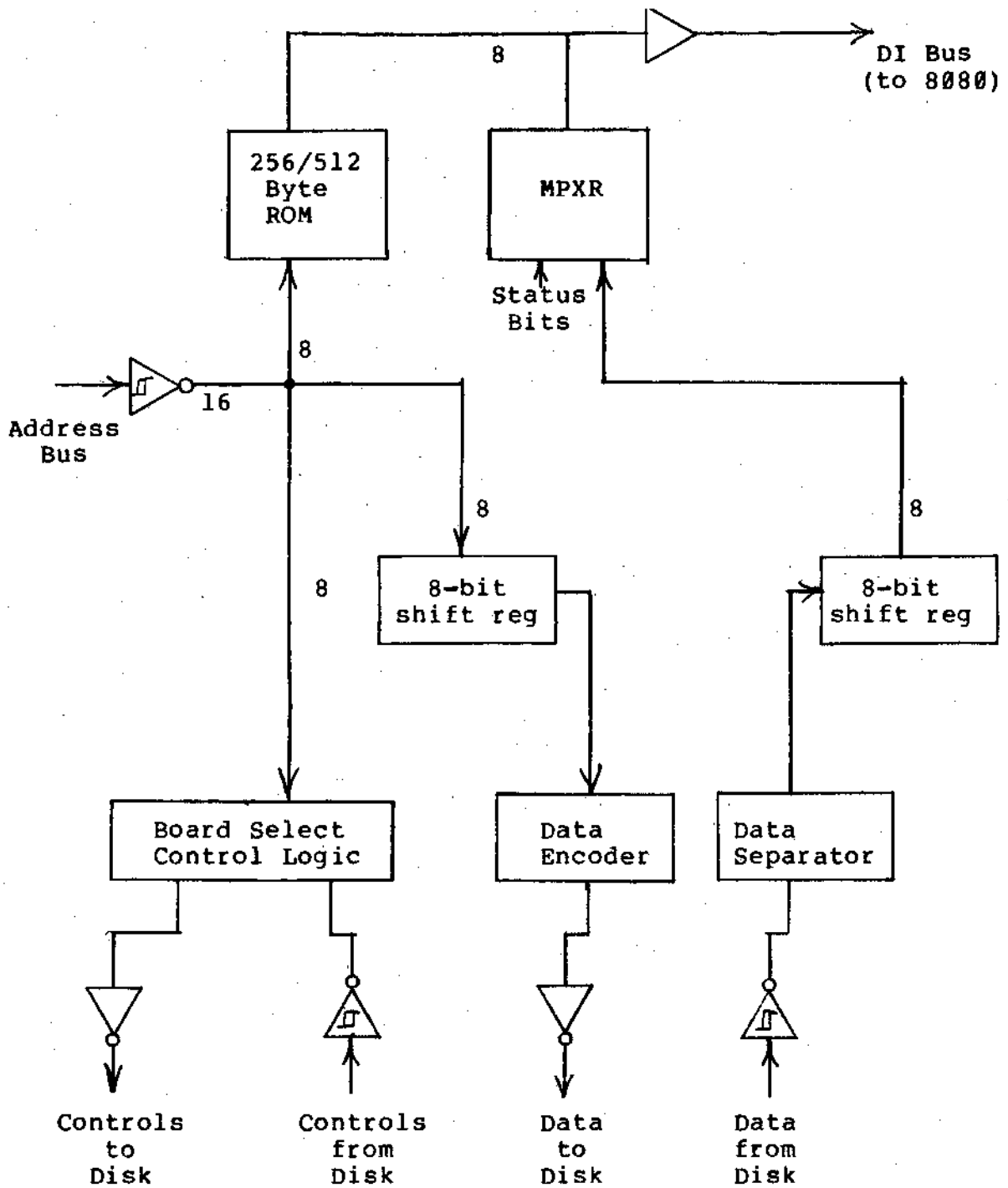

MDS Controller Block Diagram

4. On Board PROM. Controller software (8080 or Z80 machine code) is stored, in part, in two on-board 4x256 bit bipolar PROMs. These PROMs provide 256 bytes of memory. Replacing these PROMs with pin compatible 4x512 PROMs would provide 512 bytes of on-board program. The 8 low order address bits address the PROMs. The PROM outputs are driven onto the Data Input Bus.
5. Clock Circuit. The crystal controlled clock circuit (5A, 5B, 4A, 6A) provides 2 MHz clock signals to synchronize all the control circuitry.
6. Read, Write Control. A read or write command sequence begins with detection of a sector pulse. A read or write command must be issued to the controller within a 96 microsecond window after the sector pulse. Writing data begins at the end of the window. The controller writes one byte of zeros. Fifteen additional bytes of zeros are written by the software commands followed by a synchronization character, 256 bytes of data, and a cyclic check character. Writing stops at the next sector pulse. Reading starts some time after the end of the window so as to be in the middle of the written zeros. A read sequence starts in "hunt" mode. When a sync character is detected, the controller enters "body" mode. When the software issues a read command to the controller, the controller will put the CPU into the wait state until the read shift register is full. The read loop must complete in less than 64 microseconds.
7. Command Decode Logic. When a command address is issued to the controller, the 8 low order address bits are decoded to determine which command actions are to be taken and which disk controls should be performed. See the COMMANDS section for details.
8. Counters. The counters 1D, 2D, 1E, and 2E provide the timing for write data shifting, data encoding and counting, and read and write command sequencing. The counter 1G is the sector position counter. The outputs of 2E provide pseudo sector pulses in case no diskette is inserted in the drive or the drive motor is off and also allow discrimination between sector holes and the index hole. The counter 1F is used to count disk revolutions to determine when to cause automatic motor off. The counter 2B is used to count bits while reading data.

COMMANDS

Commands to the disk controller are specified by memory read references to addresses within a particular 1K byte block of the CPU address space. The 1K byte block subdivides into four cases. In all cases the high order 6 address bits (BS) are used to determine if the 1K block is addressed (i.e. the controller board is selected). The next two bits determine the subcase and the use of the low order eight bits depends on the subcase.

CASE 0 Optional PROM addressing

BS	0	PROM address
----	---	--------------

Read byte from optional 256 bytes of PROM. Case 0 can be made to address the standard PROM as well as case 1 by making the following modification to the MDS controller board. Cut the AD8/ trace that connects to 3E pin 14 and 3F pin 14 and connect those two pins to ground instead. This modification will allow the PROM to be addressed at the beginning of the MDS controller's 1K address space.

CASE 1 PROM addressing

BS	1	PROM address
----	---	--------------

Read byte from standard 256 bytes of PROM.

CASE 2 write byte of data

BS	2	Data
----	---	------

Write a byte of data to the disk. Hang if the write shift register is not empty. The low order 8 bits specify the byte to be written.

BS	3	MO	RD	BST	CC	M1	M0
----	---	----	----	-----	----	----	----

Perform a disk controller command. The commands are specified by the 8 low order address bits.

- MO if 1 then turn disk drive motors on if they are off and reset auto-motor-off timer. If 0 then no action.
- RD If one then read a data byte from the read shift register and gate it onto the Data Input Bus. Hang the CPU until the read shift register is full. If zero then gate status bits onto the Data Input Bus.
- BST If one then gate B-status byte (see below) onto the Data Input Bus. If zero then gate the A-status byte onto the Data Input Bus.
- CC Command code.
 0=load drive select register from M1,M0. Lower head on selected drive.
 1=write record, start a write sector sequence
 2=load track step flip-flop from M0.
 3=load interrupt armed flip-flop from M0.
 4=no operation
 5=reset sector flag
 6=reset controller, raise heads, stop motors
 7=load step direction from M0.(1=step in,0=step out)

STATUS BYTES

There are two different status bytes that can be read on the Data Input Bus.

A-Status

SF	WN	Ø	MO	WRT	BDY	WP	TRØ
----	----	---	----	-----	-----	----	-----

B-Status

SF	WN	Ø	MO	SP
----	----	---	----	----

- SF Sector Flag. Indicates a sector hole was detected.
- WN Window Flag. Indicates if the status byte was read during the window.
- MO Motor On. Indicates that the motors are on.
- WRT Write. Indicates that controller is ready to receive data bytes to write.
- BDY Body. Indicates that a sync char was found and that data bytes can now be read.
- WP Write Protect. Indicates that the Diskette installed in the selected drive is write protected.
- TRØ Track Ø. Indicates that the selected drive is at track Ø.
- SP Sector Position. Indicates the current sector position.

DATA FORMAT

Each diskette has 35 tracks of data. Each track is divided into 10 sectors. The rotational position of the beginning of the sectors is marked by sector holes in the diskette. Each sector is recorded using the following format. This information is recorded starting about 96 microseconds after the sector hole is detected.

Zeros	16 bytes
Sync Char (FB)	1 byte
Data	256 bytes
Check Char	1 byte

274 bytes

The check character is computed iteratively by setting it to zero and then exclusive ORing each successive data byte value with the current value of the check character and left cycling the result.

SOFTWARE

The basic low-level function of the controller is to transfer or verify 256 byte blocks of data between a specified area on the disk and a specified area of the RAM. The algorithm now described accomplishes this task. The program to perform this algorithm resides partly in the on-board PROM and partly in the DOS.

1. Start the drive motor(s) if they were off and wait 1 second (i.e. 5 sector times) for the motor to get up to speed.
2. If the disk drive to be selected is different than the drive currently selected or if the motor was off then select the new drive.
3. If the disk read/write heads are not already at the desired track then the heads must be stepped in or out to the correct track. First set the step direction flip-flop and determine the number of tracks to step. Each step is accomplished by the following sequence:
 - a. set the step flip-flop
 - b. wait at least 10 microseconds and then reset the step flip-flop
 - c. wait 2 sector times (40ms).
4. Wait until the next sector pulse and test if the disk is at

the desired sector position by reading B-status. If not then repeat this step.

5. If the data write case then
 - a. issue start write command.
 - b. wait for write status bit.
 - c. write 15 bytes of zeros.
 - d. write the sync character (FB hex).
 - e. write 256 bytes of data from RAM while computing the cyclic check character.
 - f. write the check character.
 - g. if more blocks to write on the same track then wait until the next sector pulse and repeat from step a, otherwise done.
6. If read case then
 - a. wait for sync char detection (i.e. body mode). Report an error if the sync character is not detected within 16 byte times.
 - b. read 256 data bytes into RAM while computing the check character.
 - c. read the check character and compare with the computed check character. Report an error if they are not equal.
 - d. if there are more blocks to read on the same track then wait until the next sector pulse and repeat from step a, otherwise done.
7. If verify case then all is the same as the read case except that in step b data bytes read from the disk should be compared for equality with the data in RAM. Report an error if corresponding bytes do not compare.

INTERRUPTS

The software provided with the MICRO-DISK System is not interrupt driven. The controller can cause an interrupt on any one of the interrupt lines on the S-100 bus by connecting the appropriate jumper at the lower left corner of the controller board. An interrupt will be generated at every sector pulse while the interrupt is armed in the controller. See the COMMANDS section for details of interrupt arming and disarming. Special user generated, interrupt driven software can be written which uses the controller sector pulse interrupt.

Before the low level controller software is called, interrupts should be disabled. If an interrupt occurs during data transmission then data can be lost as a result of excessive delay in the interrupt routine.

ASSEMBLY AND CHECK-OUT INSTRUCTIONS

SOLDERING TIPS

For best results use a 15 watt soldering iron or an iron with a temperature regulated tip. The tip should be no wider than the solder pads on the printed circuit board. Use only a fine gauge, rosin core solder. When soldering, keep the soldering iron tip on the pad just long enough for the solder to completely flow. If the solder does not draw up the wire then more solder is required. Use less solder if it is overflowing the pad. If the solidified joint is not shiny it may be a cold solder joint and should be remelted. The soldering iron tip should be cleaned frequently by wiping on a damp sponge.

CONTROLLER ASSEMBLY

For best results, assemble the MDS controller using the following steps. Between each step test that "ground" and "+5" are not shorted since it is very difficult to debug a short after all the components are installed.

NOTE: Orient the board with the edge connector toward you and the heat sink area to the left. The component side is now up. The silk screen legend is on the component side. The solder side has the larger IC pads.

1. Install and solder the 23 sixteen-pin IC sockets. Orient them as shown on the layout sheet and on the silk screen legend.

NOTE: IC sockets can be installed by first stuffing them into the printed circuit board, then placing another flat board over the IC sockets and finally turning over this sandwich for soldering.

2. Similarly, install the 24 fourteen-pin IC sockets.

3. Install and solder the eight resistors in the locations indicated by the silk screen legend. The hole spacing for all the resistors is .5 inches.

R1	680 ohm	blue-gray-brown
R2	680 ohm	blue-gray-brown
R3	150 ohm	brown-green-brown
R4	150 ohm	brown-green-brown
R5	150 ohm	brown-green-brown
R6	150 ohm	brown-green-brown
R7	2.2 K	red-red-red
R8	2.2 K	red-red-red

4. Install and solder the 22 capacitors in the locations indicated by the silk screen legend. The exact values of the capacitors used in the MDS system are not critical. Some kits will be shipped with values slightly different than those specified in the instructions. For example, .05uf instead of .047uf or 30pf instead of 33pf. The electrolytic and tantalum capacitors have polarity so care must be taken to insert them correctly. The "+" lead of tantalum capacitors are marked with a "+" sign. On some electrolytics, the "-" end is marked instead of the "+" end.

C1	100uf	electrolytic	"+" toward center of board
C2	6.8uf	tantalum	"+" toward top of board
C3	470pf	dipped mica	
C4	33pf	dipped mica	

The remaining eighteen .047uf ceramic disc capacitors are bypass capacitors and should be installed in the oval capacitor locations marked with asterisks on the silk screen legend.

5. Install and solder the crystal. In addition to the two leads, the top of the crystal case should be soldered to the PC board by soldering a piece of clipped resistor lead between the crystal case and the provided solder pad. A little space should be left between the crystal and the PC board to guarantee that the crystal case cannot cause shorts.
6. Bend down the three leads of the 5 volt regulator 90 degrees such that the leads go into the correct holes while the bolt holes line up. Don't solder yet.
7. Install the heat sink hardware so that the following sequence results from bottom to top: 6-32 bolt head, PC board, heat sink, regulator, lock washer, and nut. Tighten the bolt. Now solder the regulator leads.

NOTE: Heat sink grease may be used though it is not generally needed. Don't tighten the bolts too tight to avoid cracking the PC board.

8. Install the 34-pin cable connector header (J1) and solder. The right angle bent pins should be inserted into the PC board and the straight ends of the pins should be pointing toward the top of the board.

The board is now completely assembled except for inserting the IC's. Proceed with the check-out procedure.

CONTROLLER CHECK-OUT PROCEDURE

The following procedure should be followed for systematically checking-out the MDS controller. An oscilloscope is required for some steps in this procedure. These steps may be omitted initially and returned to if the board does not operate properly.

DO NOT INSERT IC'S WITH THE POWER ON.

1. Check for +5 volts at the "+" side of the tantalum capacitor.
2. Install all 47 IC's being careful to use the correct orientation. All the IC's should be oriented the same way with pin 1 to the right. Pin 1 is at the notched end of the IC package. Some IC packages have a small dot or indentation near pin 1 on the package. The three PROM's can be identified as follows

Location	Schematic Label	PROM Label
7G	PSEL	Sxx-z
3F	PGML	Lxx-yy-z
3E	PGMR	Rxx-yy-z

xx=two high order digits of PROM origin
 yy=two high order digits of DOS origin
 z =version number

The labels on the PROM's for the standard version #1 are SE8-1, LE8-20-1, and RE8-20-1.

3. The following wave forms should now be verified. The disk drive ribbon cable should NOT be plugged into the controller.

Location	Period	Description
6A pin 5	500ns	Square wave (output of oscillator, half the crystal frequency)
2A pin 11	7.5us	Almost square (signal in data separation circuit, period = one bit cell time)

2B pin 11	120us	Square (this counter counts bits during reads, period = 16 bit cell times)
1D pin 11	8us	Square (continuously running counter with period = one bit cell time)
2D pin 11	128us	Usually square (continuously running counter with period = 16 bit cell times)
1E pin 11	2ms	Square (continuously running counter with period = 256 bit cell times)
2E pin 11	32ms	Square (counter with period = one sector time if sector pulses being received, period = 4096 bit cell times otherwise (simulated sector time))
1G pin 11	320ms	High about 20% of time (counter with period = one disk revolution, if no sector pulses the period = 10 simulated sector times (simulated revolution time))
1F pin 11	5sec	Square (counter with period = 16 disk revolutions or simulated revolutions)

4. Examine the first two cells of the on-board PROM memory and verify against the following table. The addresses given are good only for the standard version. However, the values given should be the first two bytes even in a non-standard version.

Address	Value(hex)
E900	31
E901	14

5. This step is for check-out of the data read and decoding logic. The ribbon cable should not be plugged into the controller board for this step. Tack solder a jumper to 1D pin 12. The other end of the jumper can be connected to READ DATA/ by touching it to the bottom of resistor R6. The signal at 1D pin 12 should be a 4us square wave. This simulates a continuous string of "one" bits. When the jumper is not connected continuous "zero" bits should be decoded. The following table indicates signals that should be observed when the jumper is connected and not connected to READ DATA/.

Signal	Jumper not connected	Connected to bottom of R6
NICE READ DATA 3A pin 6	always low	.5us pulse every 4us

SEP DATA/ 6B pin 6	always high	.5us pulse every 8us
READ BIT SHIFT 2A pin 15	.5us pulse every 7.5us	.5us pulse every 8us
SAVED READ DATA 9G pin 9	always low	8us period square wave
READ SHIFT REG 5E pins 3,4,5,6 10,11,12,13	always low	always high

6. This step checks-out the timing signals for reading and writing. For this step the drive should have its power on and the ribbon cable should be connected between drive and controller. The following program (valid for standard version only) should be entered into memory and run starting at address 2000 hex.

```

2000 3A14EB GO LDA EB14 CLEAR SECTOR FLAG
2003 3A10EB WAIT LDA EB10 READ A-STATUS
2006 E680 ANI 80H
2008 CA0320 JZ WAIT WAIT FOR SECTOR FLAG
200B 3A04EB LDA EB04 SET WRITE REQ
200E C30020 JMP GO

```

With the scope positive edge-triggered on the signal SECTOR FLAG (6A pin 8) the following signals should be observed.

SECTOR FLAG 6A pin 8	High for 30-40us then low
WINDOW 9F pin 6	High for 96us then low
TRANS 9F pin 9	One 8us positive pulse after 96us
HUNT 9E pin 6	Low for 480us then high
WRITE REQ 9G pin 6	Low for 65-75us then high
WRITE 9E pin 10	Low for 104us then high
WRITE DATA/ 8B pin 6	High for 104us then 8 negative pulses at 8us intervals then random negative pulses at 4 or 8us intervals

POWER BOARD ASSEMBLY

There are three different ways that power can be supplied to a disk drive.

- a. Direct hook-up of regulated +5 volts and +12 volts from an existing regulated power supply. In this case the Power PC Board is not used and the four conductor power cable should be connected directly to the power plug as described in Step 5 below. The other end of the power cable should be connected to the corresponding outputs of the regulating power supply.
- b. Use the Power PC Board to regulate power from an existing unregulated power supply. Under most circumstances the power supplies in the following computers provide adequate power to supply one drive: IMSAI I-8080, Altair 8000b, and POLY-88. In general, compare the disk drive power requirements against the power supply capacity to see if this arrangement will work. If this power supply option is to be used then follow the instructions below starting at step 1.
- c. Use the North Star Power Supply option (MDS-PS). The MDS-PS provides all the components needed to obtain unregulated power from a 115 volt AC line. Some of the MDS-PS parts mount on the Power PC Board and some mount to the North Star MICRO-DISK Cabinet (MDS-CAB) or elsewhere. If this option is used then start assembly with Step 1 below and continue with the MDS-PS assembly instructions.

The silk screen legend is on the component side of the PC board and the traces are on the solder side.

1. Install and solder the two 1% precision resistors in the locations indicated by the silk screen legend.

R1	232 ohms
R2	1.96 K

2. Bolt the +5 volt regulator (7805 or 340T-5) to the inside of the 295-2 heat sink so that the following sequence results from outside in: 6-32 bolt head, heat sink, regulator, lock washer, and nut. The regulator leads should point the same direction as the heat sink mounting posts.
3. Install the regulator heat sink assembly by inserting the regulator leads in the correct holes on the PC board and then inserting the heat sink mounting posts in their holes. Now solder the regulator leads.

The heat sink mounting holes may require a slight amount of reaming. Do not over ream as the heat sink should fit snugly into the holes for mechanical support.

4. Mount the 690-3-B heat sink and LM317K regulator on the PC board such that the following sequence results from back to front: 6-32 bolt heads, PC board, heat sink, regulator, lock washers, and nuts. Two bolts are required to mount this regulator. Position the heat sink as far from the edges of the PC board as possible and tighten the bolts. Now solder the two regulator leads.
5. Assemble the disk drive power plug as follows. Cut off a piece of 4-conductor power cable about 3 inches long. Remove an inch of outer insulation from both ends. Strip 1/4" of insulation from each conductor at both ends. Crimp and solder each of the four power plug pins to the conductors at one end. Finally, insert the power plug pins into the power plug using the following color code: +5 red, +12 green, ground black and white. Consult the OEM Manual (sections 4.2 and 5.2) for the correct connection of power to the power pins.
6. Solder the four wires coming from the power plug assembly to the appropriately labeled holes in the lower righthand corner of the PC board. The wires should be inserted into the PC board from the solder side.

NOTE: If the MDS-PS power supply is being used, then skip the remaining steps of these instructions and go on to the MDS-PS assembly instructions.

7. Insert and solder the two .047uf ceramic disc capacitors (C1 and C2) in the locations indicated by the silk screen legend.
8. The four wires in the 5-foot power cable should be soldered to the four holes in the PC board labeled 0v, 0v, 9v, and 18v using the following color code: 0v black, 0v white, 9v red, 18v green. The wires should be inserted into the PC board from the component side.
9. Connect the other end of the power cable to the appropriate power points of the unregulated power supply. For example, the cable can be connected to the power pins at an unused position on the S-100 bus mother board. Consult the computer reference manual for details. If the disk drive is to be mounted inside a cabinet (MDS-CAB) then the power cable should be passed through a hole in the back of the cabinet and clamped with the provided strain relief bushing before connection to the power source.
10. Check that the regulators are providing +5 and +12 volts at the power plug before plugging into the drive.

11. Mount the PC board to the back of the disk drive as follows. Carefully remove the two bolts that mount the small PC board to the back of the disk drive. Use the two longer bolts and spacers so that the following sequence results from back to front: bolt head, power PC board, longer spacer, small PC board, shorter spacer, and disk drive. The power PC board should be mounted with the solder side toward the drive.

The power board is now ready to use.

POWER SUPPLY (MDS-PS) ASSEMBLY

Start by assembling the power PC board following steps 1-6. If the board is being converted from use with an unregulated power source then the two capacitors C1 and C2 should be removed. Now continue with the following steps.

1. Install and solder the two electrolytic capacitors in the locations indicated by the silk screen legend. Be sure to mount both capacitors with the "+" side oriented as indicated by the silk screen legend.

C3	2500uf	15wvdc	electrolytic
C4	3000uf	30wvdc	electrolytic or
	2400uf	25wvdc	electrolytic

2. Install and solder the four rectifier diodes. Be sure to observe the correct polarity when installing the diodes. The banded end of the diode should correspond to the band marked on the silk screen legend.

D1	MR501	3 Amp
D2	MR501	3 Amp
D3	1N4002	1 Amp
D4	1N4002	1 Amp

3. Mount the transformer to the cabinet using the 6-32x1/2" bolts such that the following sequence results from bottom to top: bolt head, cabinet, transformer, lock washer, and nut. The transformer should be mounted so that the solder lugs are away from the back of the cabinet.
4. Mount the fuse holder in the leftmost hole (looking from the back) and the toggle switch in the center hole.

5. Pass the power cord through the rightmost hole and solder one wire to lug 1 of the transformer. Cut the other wire shorter and solder it to one of the toggle switch lugs. Clamp the power cord to the cabinet using the strain relief bushing.
6. Solder the other lug of the toggle switch to the lug at the end of the fuse holder with a short piece of hook-up wire and then solder the other lug of fuse holder to lug 2 of the transformer.
7. Put the fuse in the fuse holder.
8. Solder the three transformer lugs 3, 4, and 5 to the three corresponding holes in the power PC board marked T3, T4, and T5 on the silk screen legend using short pieces of hook-up wire (about 4 or 5 inches).

Now follow steps 10 and 11 of the Power Board assembly instructions and the power supply is ready to use.

SYSTEM INTEGRATION

Before using the MICRO-DISK System the various components must be configured and integrated with each other.

DISK DRIVE CONFIGURATION

If the system is to be configured with only one disk drive connected to the controller then no modification is required for the disk drive. If two or three drives are to be connected to the controller then the following disk drive modifications must be made.

1. There is a trace on the large disk drive PC board labeled MUX (located between IC's 2C and 2D). This trace must be cut on all the drives.
2. The drive number for each drive must be programmed using the program shunt (located at 1F) on the disk drive PC board. The three metal straps labeled DS1, DS2, and DS3 specify whether the drive is to be selected as drive 1, 2, or 3, respectively. For each drive, the strap for the desired drive number should remain connected and the other two straps should be disconnected. Straps can be disconnected by removing the strap assembly from the DIP socket, spreading the pins for the undesired straps and plugging the assembly back in such that the undesired pins are not inserted into the DIP socket. Each drive should be programmed with a different drive number. One drive must be number one.
3. The other five straps (labeled T1, T2, T3, T4, and T5) in the program shunt (located at 1F) connect five pull-up resistors for line termination on the ribbon cable. Only the drive plugged in at the end of the ribbon cable should have the pull-up resistors connected. Additional drives plugged in along the cable should have the five straps disconnected. It is recommended that drive one be at the end of the cable.

CABLE CONFIGURATION

The ribbon cable assembly supplied with the MICRO-DISK System is ready to use with a one disk drive system. An additional edge connector plug must be crimped onto the cable for each additional drive. Be sure these plugs point the same way as the edge connector plug at the end of the cable (and opposite to the controller board plug). The spacing of the plugs along the ribbon cable should be determined by the desired physical

positions of the disk drives. With the component side of the controller board facing toward you, the ribbon cable should be plugged into the controller board so that the cable extends away from you. If the cable comes out of the plug toward you then it is plugged in wrong. The drive edge connector plugs should be plugged into position J1 on the drive PC board such that the cable going toward the controller runs out the bottom of the plug. The cable should be routed around the power PC board by making a flat 90 degree fold in the cable immediately below the edge connector plug. Some tape should be applied to the back of the power PC board to avoid abrasion of the ribbon cable where it touches the power PC board.

CABINET ASSEMBLY

1. Mount the four rubber stick-on feet at the four corners of the bottom of the cabinet.
2. Mount the disk drive (with power PC board if required) to the bottom plate of the cabinet with the four flat head screws. The MDS-PS power supply, if used, should be mounted into the cabinet.
3. The cabinet cover is secured with six pan head 6-32 screws, two on each side and two in the back.

INTEGRATED SYSTEM CHECK-OUT

All components of the system should now be assembled and ready to be put together.

1. Turn off the computer power if it is on and plug the MDS controller board into the computer and connect the ribbon cable between the controller and disk drives as directed in the Cable Configuration section.
2. Turn on the power and check that the power at the drive power plug is +5 and +12 volts at the proper pins. Then turn off the power and plug the power plug into connector J2 on the drive PC board.
3. Turn on the computer and disk drive power and then enter and run the following program at 2000(hex) in RAM. The program is valid only for the standard controller address. The program should cause the motors on all the drives to turn on. The automatic motor turn-off should cause the motors to stop in about 5 seconds.

```
2000 3A 80 EB LDA EB80
2003 C3 03 20 JMP 2003
```

4. Examine address EB20. This should cause the MDS controller to place the B-status byte on the Data In bus. The sector position field (low order four bits) should be constantly changing with values between 0 and 9.
5. Check that the head carriage guide on the disk drive is in the spiral groove on the stepper motor cam. Sometimes the guide is knocked out of the groove during shipment.
6. With no diskette inserted in the drive, starting the bootstrap program at the bootstrap starting address (E900 in standard version) should cause the following actions to occur. The motors for all drives will turn on. After one second the head will be selected on drive number 1 (loud click sound). The disk head on drive number 1 will now step out to track zero (0 to 35 rapid muted clicks). After this the computer will endlessly loop within the PROM program.

The disk system is now integrated, checked-out, and ready for use. Proceed to the directions in the Disk Operating System Manual for personalizing the disk software. Consult the OEM manual for proper operation procedures before using the disk drive or diskettes. Also, consult the OEM manual for instructions on how to write protect a diskette. ANY DISKETTE THAT CONTAINS INFORMATION THAT YOU WOULD NOT LIKE TO SEE ACCIDENTALLY DESTROYED SHOULD BE WRITE PROTECTED. A diskette can be write protected by covering the write protect notch with a piece of masking tape folded over the edge of the diskette.

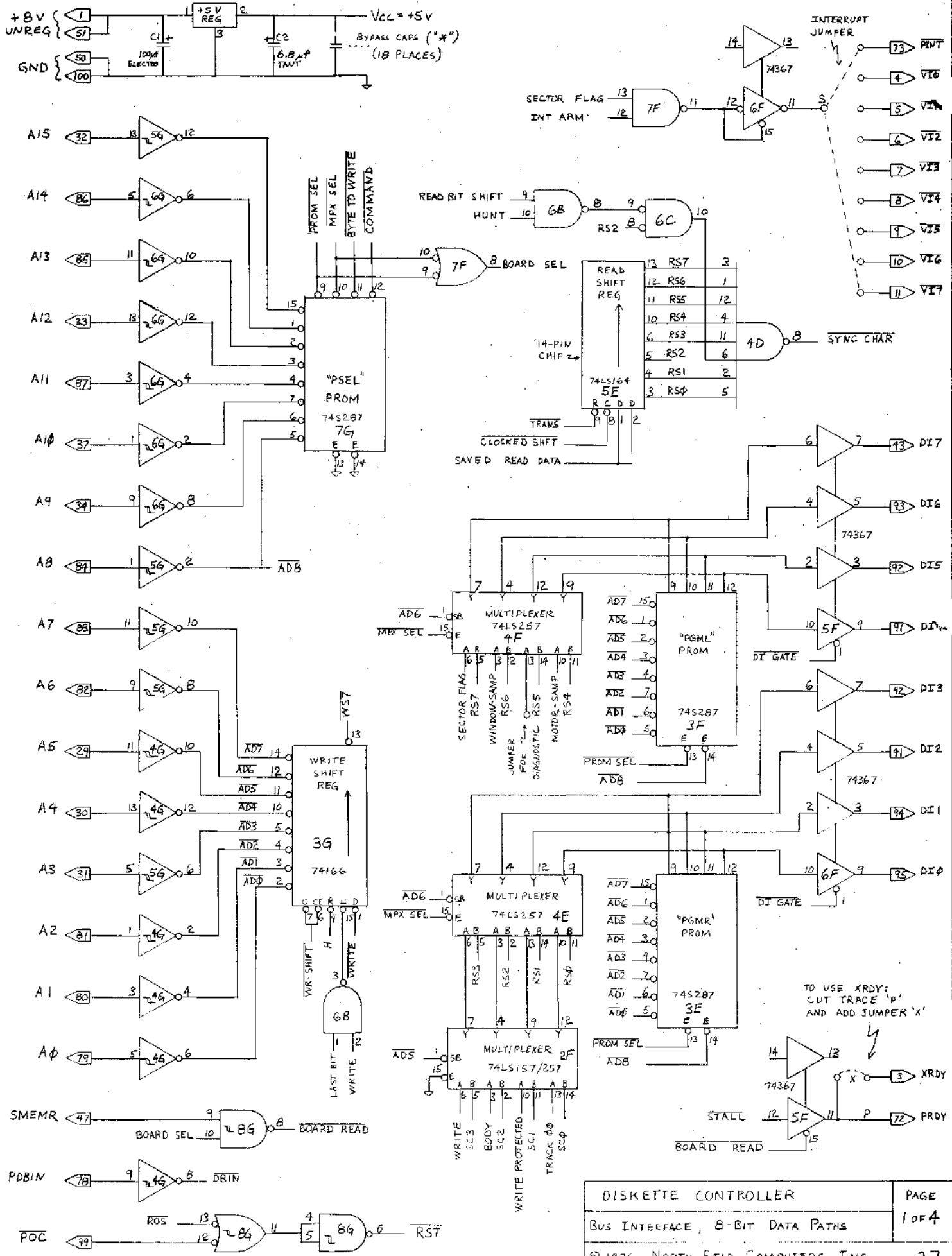

+8V UNREG { 1, 51 }
 GND { 50, 100 }
 +5V REG { 1, 2, 3 }
 VCC = +5V
 BYPASS CAPS ("X") (18 PLACES)
 C1: 100µF ELECTRO
 C2: 6.8µF TANT

