

MD 11

HARD DISK MICRO DECISION

USER'S GUIDE

MORROW 

PRELIMINARY EDITION

MORROW

<415> 430-1970

Dear MD-11 owner,

We regret that your software assortment is not quite complete. Quest, Inc. and Audio Light, Inc. are still modifying Quest Bookkeeper and The Backfield for the MD-11. These programs will be available on diskette through your dealer around March 1, 1984.

In the meantime, you should use the following backup procedure to protect your valuable data files:

1. Make a note of the names of the files and their user numbers. You can tell a file's user number by carefully reading the "file cabinet" screen that appears before you run NewWord, Personal Pearl, or LogiCalc.
2. Format a blank diskette by selecting 4 at the Co-Pilot Utility Menu. Specify 1 for normal format. Leave the diskette in the drive.
3. Escape from the menu system by pressing the ESC key at the Co-Pilot Main Menu.
4. When you see "A>", type:

user #

where "#" is the user number of the file to be backed up. Press the RETURN key. The CP/M prompt changes to "#A>".

5. Now type:

pip B:=filename

and press RETURN. "Filename" is the name of the file to copy: first name, period, and last name (if used). For example, to back up a file named "crucial.fil," you'd type pip B:=crucial.fil. Repeat this step for every important file that has the same user number.

6. Go back to step 4 if there are important files in other user numbers.

You can use the same diskette until it gets full. Check its fullness with the Utility Menu option "Check disk space and file size." To copy a file back from the floppy onto the hard disk, insert the backup diskette in the drive and follow steps 3 through 6 above. But this time, the command in step 5 is:

pip A:=B:filename

To restore the file in the example above, the command would be pip A:=B:crucial.fil. When you're finished "pipping", press the RESET button to get back into the Menu system.

-- (*) --

Consider this booklet your tour guide. It is written for people like yourself who have chosen Morrow's MD-11 hard disk CP/M computer system. It is meant to get you started with the MD-11, and to show you some good maintenance habits. Be aware that it doesn't teach you how to use your software (NewWord, Personal Pearl, etc.), since these are covered in their own manuals.

We want to get you hooked up and running right away. So, if you're a complete newcomer to Computersville, you may want to skim Appendix B for a few fundamentals like how to handle diskettes. Appendix A lists the MD-11's general specifications.

NOTE: Early versions of the MD-11 software assume you are using a Morrow MDT-60 terminal. The first page of Chapter 1 is written for software versions that don't make this assumption. Whichever version you have, this manual will still apply.

-- (*) --

Copyright 1984 by Morrow, Inc.

World rights reserved.

No part of this publication may be reproduced, transmitted, stored in a retrieval system, or translated into any language or computer language, in any form or by any means, electronic, mechanical, magnetic, optical, chemical, manual or otherwise, without prior written permission of Morrow, Inc.

DISCLAIMER

No representations or warranties, express or implied, are made with respect to the contents hereof, including, but not limited to, the implied warranty of merchantability or fitness for a particular purpose. Further, Morrow, Inc. reserves the right to revise this publication and to make changes from time to time in the content hereof without obligation to notify any person of such revision.

NewWord is a product of NewStar Software, Inc.

LogiCalc is a product of Software Products International.

BASIC-80 is a BASIC programming language developed by Microsoft, Incorporated.

BaZic is a BASIC programming language developed by Micro Mike's, Inc.

PERSONAL PEARL is a product of Relational Systems International Corp.

Quest is a trademark of Quest, Inc.

Micro Decision, Correct-It, PILOT and the Co-Pilot Menus are products of Morrow, Incorporated.

CP/M 3.0 is an operating system developed by Digital Research, Incorporated.

MD-11 USER'S GUIDE

----- CONTENTS

CHAPTER 1. WIRING IT UP AND FIRING IT UP

Terminals That Work Well With the MD-11	1-1
Printers That Will Prove Convenient to Use.	1-2
Unpacking	1-3
Setting Things in Place	1-4
Connecting the Terminal	1-5
Connecting the Keyboard	1-6
Connecting the Printer.	1-6
Parallel Printers.	1-7
Serial Printers.	1-8
Unfortunately You're Not Quite Finished	1-8
Terminal Setup	1-8
Checkpoint A.	1-10
The Next Steps.	1-10
Fire That Baby Up	1-11
Checkpoint B.	1-11
Checkpoint C.	1-12
If You Didn't Make it to Checkpoint C.	1-14
Setting Up Serial Printers.	1-14

CHAPTER 2. USING YOUR MD-11 FOR THE FIRST TIME

The Main Menu, Revisited.	2-2
A Sampling of the Software.	2-3
NewWord.	2-3
SuperCalc.	2-6
Correct-It	2-6
Personal Pearl	2-7
Quest.	2-8
The Backfield.	2-8
BASIC and BAZIC.	2-10
PARK	2-10
ESC: Exit to CP/M.	2-11

APPENDIX B. THE ABSOLUTE ESSENTIALS

Types of Software	B-1
Computer Hardware	B-3
Disks and Disk Drives	B-3
Disk Drive Letters	B-4
The Hard Disk.	B-4
Floppies: Why Are They So Sensitive, Anyway?	B-5
Formatting Diskettes	B-6
Write Protection	B-7
Procedure for Inserting Diskettes.	B-8
About Your Keyboard	B-9
ESC Key.	B-9
CAPS LOCK Key.	B-9
SHIFT Key.	B-10
CTRL Key	B-10
BACK SPACE Key	B-10
DELETE Key	B-10
RETURN Key	B-11
NO SCROLL Key.	B-11
Numeric Keypad	B-11
Special Symbol Keys.	B-11
Function Keys.	B-12
Cursor Keys.	B-12

APPENDIX C. GLOSSARY

APPENDIX D. CONNECTING DEVICES TO THE MD-11

Types of Transmission	D-1
The RS-232 Connectors.	D-3
The Centronics Connector	D-4
The Auxiliary Connector.	D-4
The RS-422 Connector	D-5
Crash Course in Baud Rates and Protocol	D-5
The SETUP Program	D-6
Using Two Printers.	D-9
Jumper Options.	D-10
JPA/JPB Factory Settings	D-13
JPA and JPB Settings for Modems.	D-15
Factory Settings for JPC	D-17
JPC Settings for Modems.	D-20
CP/M Device Definitions	D-21
Port Addresses.	D-21
RS-422 Pin Connections.	D-22
The Expansion Connector	D-23

CHAPTER 5. ERRORS AND OTHER NUISANCES

Drive Not Ready	5-2
Write Protected	5-2
Not Found	5-2
Data Address CRC Error.	5-3
ID Address CRC Error.	5-3
Data Error.	5-3
Equipment Failure	5-3
Media Failure	5-3
Seek Error.	5-4
Unable to Remap	5-4
Unknown Error Code.	5-4
Error Message Responses	5-4
R - to Try Again	5-4
A - to Abort	5-5
I - to Ignore.	5-5
Nonrecoverable Errors	5-6
Select Error	5-6
Disk Read Only	5-6
File Read Only	5-6
Summary	5-7

APPENDIX A. ABOUT YOUR SYSTEM

The Operating System.	A-1
The Hard Disk Itself.	A-1
How Floppies Fit Into the Picture	A-2
Virtual Drives.	A-2
System Hardware	A-3
System Software	A-4
System Requirements	A-5
Optional Hardware	A-6
Printers	A-6
Modems	A-6
Additional Software	A-7
The Co-Pilot Menus.	A-7

CHAPTER 2 continued

The Utility Menu: Your Tool Box	2-12
Display a Directory.	2-13
View or Print a File	2-13
Copy a File or Files	2-15
Format a Diskette.	2-16
Check Space and File Size.	2-17
Execute a CP/M Command	2-18
Rename or Erase a File	2-20
Basic Training in CP/M	2-21
Whew!	2-22

CHAPTER 3. ABOUT THE PROGRAMS IN USER 0

PARK.COM.	3-2
FORMAT.COM.	3-3
SETUP.COM	3-4
PILOT.COM	3-4
PROFILE.SUB	3-5
BACKUP.COM.	3-6
FOREIGN.COM	3-7
INIT.COM.	3-8
COPYSYS.COM	3-9
LOAD.COM.	3-10
VERIFY.COM.	3-11

CHAPTER 4. MD-11 QUESTIONS AND ANSWERS

Restrictions on File Names.	4-1
Disk Drive Letters.	4-2
Booting From the Floppy	4-3
Disabling the Menus	4-4
Booting Defined	4-5
Modifying NewWord	4-6
Printing and Typing Simultaneously.	4-7
Adding Other Software to the Hard Disk.	4-9
Using Foreign Diskettes	4-11
Translating the Menus Into Another Language	4-13
When to Press RESET, and When Not To.	4-15
The RS-422 Connector.	4-16
Changing Hardware After Installing the Software	4-16
Learning About CP/M	4-18
Running Your Programs Directly From CP/M.	4-18

CHAPTER 1

----- WIRING IT UP AND FIRING IT UP

By the end of this chapter, you will be through all the rigamarole of unpacking, connecting cables, testing the hardware, and installing the software. This should take less than an hour. Be sure you have the following equipment:

- o Terminal and its cable
- o Printer (optional) and its cable
- o 10 soft-sectored, double-sided diskettes

You can get by with just one diskette for the moment, so don't rush off to the dealer if you don't have ten.

The only thing that can hang you up is having a truly unusual terminal or printer. Check the lists below to find your hardware, or a model that operates exactly the same as yours. If you don't find them, ask your dealer about the "emulation capabilities" of your terminal or printer. In any case, you'll still be able to work through all the steps but you may be left wishing you'd bought a more popular model.

Terminals That Work Well With the MD-11

Any Morrow model (MDT-60 or MT-70 recommended)
ACT 5A
ADDS Viewpoint
DEC VT52 or VT100
Hazeltine 1420 or 1500
Heath H19
IBM 3101
Lear Siegler ADM-3A, ADM-5, ADM-22, and ADM-31
Qume 102
SOROC IQ-120
Teleray
Televideo 910, 912C/920, and 925/950
Visual 200
Wyse

If your terminal (or one yours can emulate) isn't up there, and you see a similar list onscreen during this phase, select "None of the above".

Printers That Will Prove Convenient to Use

The MD-11 will work with practically any printer, but your wordprocessing program, NewWord, is a bit more picky. When you reach the point of installing NewWord, you'll see this list:

Simple	NEC Spinwriter 2000 series
Draft printer	NEC Spinwriter 3500 series
Typewriter printer	NEC Spinwriter 5500 series
Qume Sprint 11	Okidata Microline 84 (step 2)
Silver Reed EXP550	Okidata models 92/93
Diablo 1610/20/40/50	Epson MX80/100 & FX80/100
Diablo 630	C.Itoh Prowriter
	Morrow's MP100/200/300 series

If you see yours in there (or one yours can emulate), great. If not, you'll have to figure out whether yours qualifies as a "Draft" or "Typewriter" printer. Read about this under Printers in the Encyclopedia section of the NewWord User's Guide. (Hint: if in doubt, pick Draft printer.)

With those preliminaries behind us, let's move on.

Unpacking

You don't really need instructions for unpacking, do you? Since you're reading this, you must have exercised a little initiative already. However:

NOTE: Keep your packing materials. The MD-11 carton was specially designed to give maximum shock protection for the hard disk during shipment.

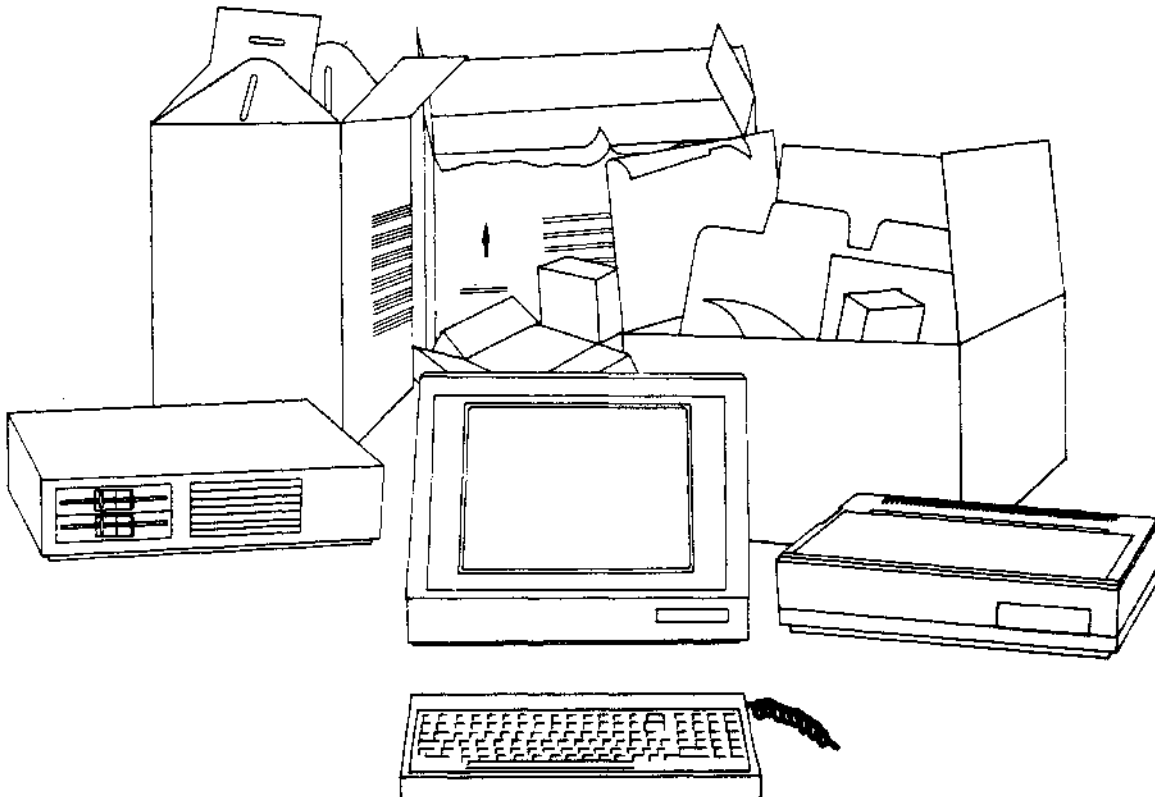

Q: What is wrong with this picture?

Setting Things in Place

Any sturdy desk or table top is alright. Treat the hardware as you would a fine component stereo. Here are a few hints that might help you out:

1. Consider the comfort of your arms and shoulders when deciding where to put the keyboard. Most normal desk tops are really too high for long-term typing.
2. Put the screen at a convenient level for your eyes, especially if you wear bi-focals.
3. Make sure you can reach the power switch on the rear of the MD-11 without too much strain. (It was intentionally put in a less-than-convenient place so you'd never shut it off by accident.)
4. Don't strive for the perfect arrangement just yet. You'll still be moving things around when you're attaching the cables, which comes next.

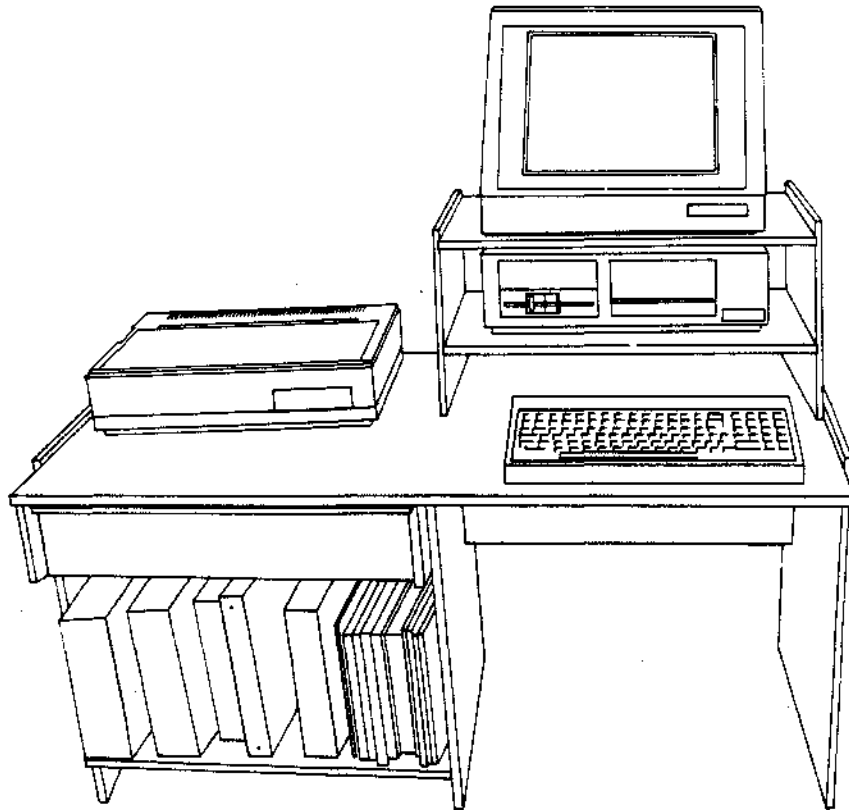

Connecting the Terminal

DON'T PLUG ANYTHING INTO POWER SOCKETS YET.

Locate the cable that came with your terminal. If you happen to have a serial printer, the terminal and printer cables might look almost identical. Endeavor not to confuse them.

You'll be happy to know that the plugs on the terminal cable cannot be connected upside down, and it doesn't matter which end of the cable is which. So proceed to connect one end to the TERMINAL socket on the MD-11, and the other to the socket on the terminal.

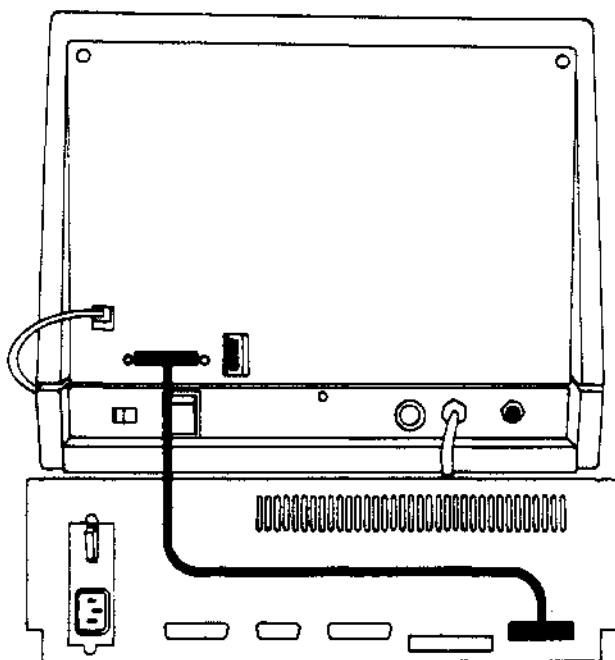

Figure 1-1: Terminal Cable Connection (MDT-68 Terminal shown)

If the terminal has two possible places to connect the cable, pick the one labelled MAIN, RS-232, or MODEM. Avoid connectors labelled PRINTER or AUX.

Connecting the Keyboard

Some terminals won't require this step. But most that have detachable keyboards will have a coiled cable that plugs into the terminal somewhere. Check your terminal manual should the socket elude you.

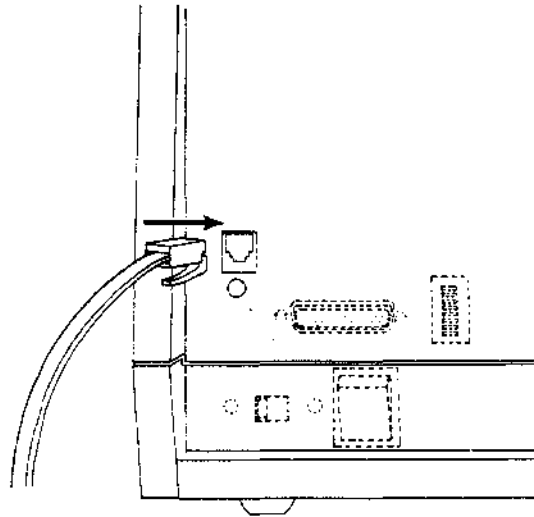

Figure 1-2: Connecting the MDT-60 Keyboard

Connecting the Printer

There are two possibilities: you have a serial printer, or a parallel (also called "Centronics") printer. A few printers can play it either way.

Parallel printers usually have wide, flat cables with connectors that differ from one end to the other. Serial printers have thin round cables with connectors just like those on the terminal cable.

Parallel Printers

It should be obvious that one end of the cable matches the oblong connector on the printer. Go ahead and make this connection. You can't do it upside down. If there are little metal clips that fasten the plug to the printer, try clipping them. But if they give you too much trouble, forget it (unless you live in an active fault zone).

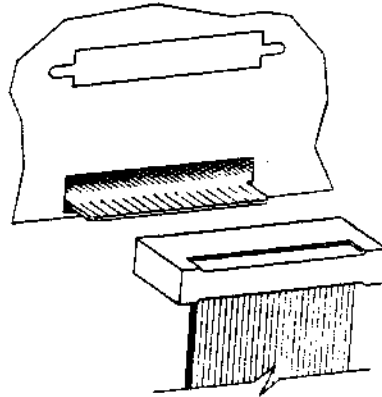

Figure 1-3: Connecting the 34-pin Plug

Now comes the only place where you could go wrong. The other end of the parallel cable attaches to the edge of the board sticking out of the MD-11's rear (labelled CENTRONICS PARALLEL). It is possible to connect this one upside down. If you follow the illustration above you'll be alright. The ribbon of wires should flow out of the **BOTTOM** of the connector.

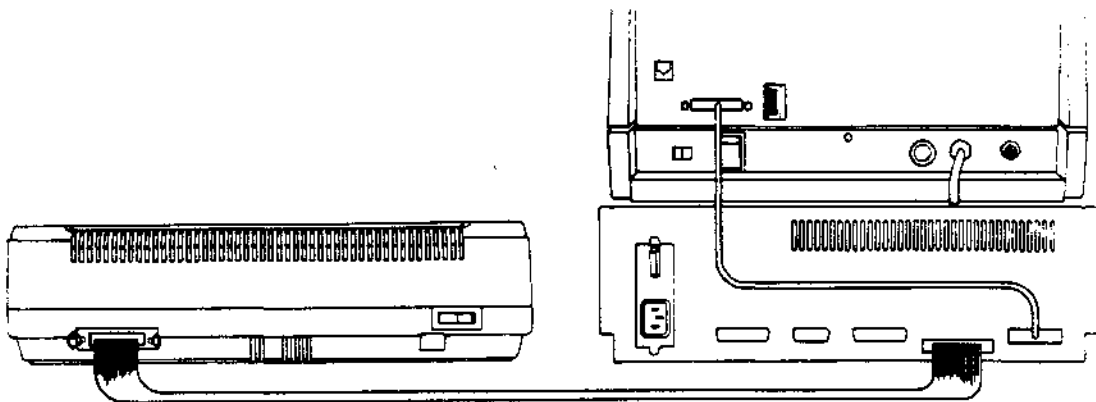

Figure 1-4: Connecting a Parallel Printer (MP-100 shown)

Serial Printers

This is about the same as connecting the terminal. One end of the printer's cable goes to the MD-11 connector labelled PRINTER / MODEM, and the other goes to the printer. Enough said.

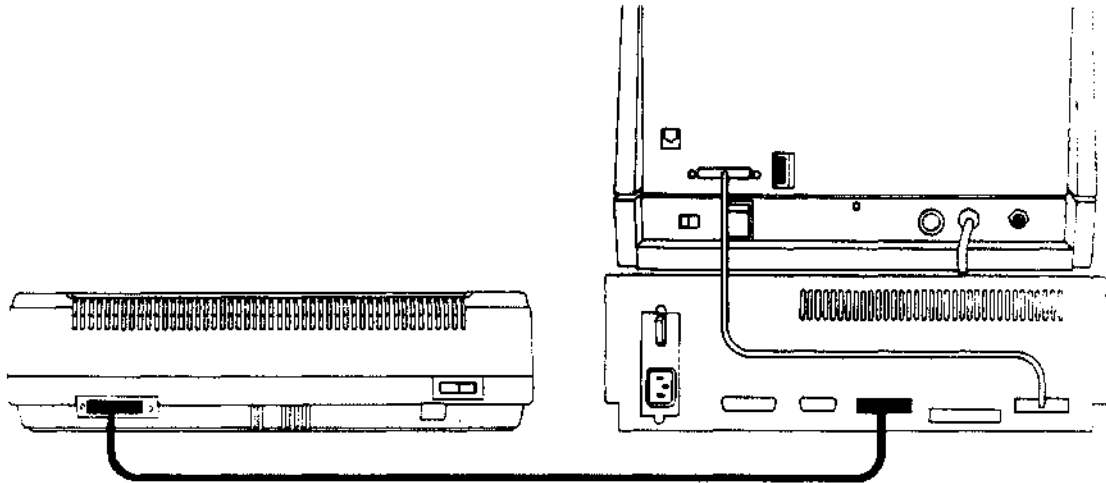

Figure 1-5: Serial Printer Connection (Mythical printer shown)

Unfortunately You're Not Quite Finished

That was easy enough. Now things can get a little murky. The MD-11 comes from the factory with a few assumptions built in; you have to make sure that the printer and terminal adhere to these assumptions, and if that's not possible, that you change the MD-11's picture of the world accordingly. We'll deal with the terminal now, and the printer a little later.

Terminal Setup

Most terminals have itsy-bitsy switches on them that determine how they'll communicate with a computer. Others use "software settings" instead of switches. In either case, you need to verify that the terminal is set up right for the MD-11. The procedure for doing so is different for every model of terminal, so consult your terminal manual or make your dealer do it. There is a real possibility, however, that your terminal will be set up correctly even before you unpack it.

We'll use the Morrow MDT-60 terminal as an example. The assumptions that the MD-11 is making are these:

Baud rate: 9600
7 data bits
2 stop bits
Full duplex
No parity - parity bit set to "space" (0)

The figure below shows the proper switch settings for the MDT-60. (These switches are clearly visible on the rear of the terminal.)

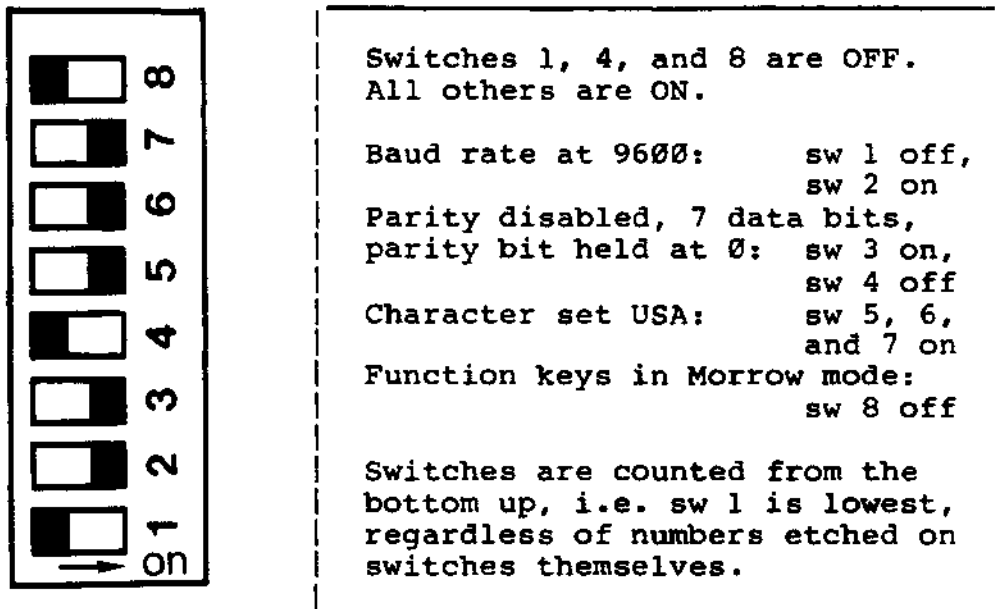

Figure 1-6: MDT-60 Setup Switches, Properly Set for MD-11

The terminals that use software settings for these functions (such as the Morrow MDT-20) will require that you plug them in and turn them on before you can check anything. Feel free to do this, but LEAVE THE MD-11 UNPLUGGED.

In the extremely unlikely case that you have an ancient terminal that can't talk at 9600 baud, tell your dealer "Hey - how about running SETUP on this MD-11 to match my terminal's baud rate?" He'll have to use a 9600 baud terminal to do this.

There are several other details about your terminal's operation that are under the control of additional switches. Don't worry about them now. Just focus on baud rate, full duplex, and bit patterns.

Incidentally, we're not pausing to define every term at this stage. If not understanding words like "baud rate" makes you uptight, refer to the glossary at the end of this manual. But there is really no need for you to understand such details.

Checkpoint A

- o Your terminal and printer are connected to the MD-11.
- o You've verified that your terminal is set up for the MD-11.

The Next Steps

1. This next step is very important: REMOVE THE CARDBOARD PACKING MATERIAL FROM THE INSIDE OF THE FLOPPY DISK DRIVE. Leave the latch open. Never try to close it with no diskette inside, by the way.
2. Make sure the power switch on the MD-11's rear is turned OFF. Down is off.
3. Connect the MD-11 power cord into its socket on the rear panel.

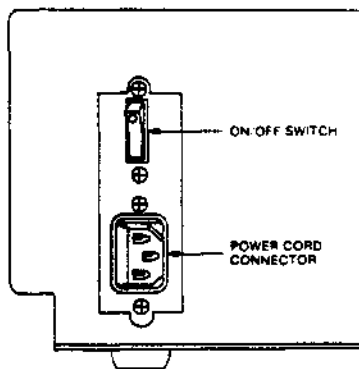

Figure 1-7: MD-11 Power Connector and Switch

4. Plug the power cords for the MD-11, terminal, and printer into a wall outlet or power strip. USE ONLY GROUNDED OUTLETS. And don't just break off the grounding lead from the plugs. This is a computer, not a power saw.
5. If you like, go ahead and arrange the hardware into its final positions now.

Fire That Baby Up

Turn the terminal on first. You may hear a beep. In a few seconds, your cursor should appear. The cursor is a small rectangle or bar of light, about the size of one character. It may blink. If you don't see anything on the screen after a reasonable pause, check the terminal's brightness or contrast control. Rotate it from one extreme to the other. If you're sure you have power and you still don't see a cursor, tell your dealer.

Assuming your cursor is there, reach around the right side of the MD-11 and flip the power switch ON. You should hear the hard disk start to whir. A light should be glowing on the lower right corner of the front panel.

And voilà. The computer has sprung to life.

Checkpoint B

- o The cursor was clearly visible on the terminal screen.
- o When you turned on the MD-11, a message immediately appeared on the screen. Among other things, it reported that it was "Testing memory:". After passing this test, the software installation process commenced automatically.

If everything's gone right so far, stop reading this and read your screen instead.

Several things could have gone wrong at this point, although they're unlikely if you've followed the instructions carefully.

First possibility: When you turned on the MD-11, nothing happened. No hum, no lights glowing. Check its power cord connections and the outlet.

Second: Upon turning the MD-11 on, it hummed etc., but nothing happened on the screen. Assuming the cursor is visible, check the terminal's cable connection.

Third: You saw some kind of gibberish appear on the screen. Most likely your terminal is set to the wrong baud rate. After resetting this, turn the terminal off and back on to make the new rate take effect. Then press the RESET button on the front of the MD-11 (the little button on the lower right with the light in it). This starts everything over.

Fourth: The MD-11 failed the memory test, as indicated by the message "RAM (or ROM) error." We've yet to see this happen, but if you're that one in a million, report it to your dealer.

-- (*) --

Now then. If your hard disk is still in perfect condition after its trip from the factory, you'll proceed to install NewWord, SuperCalc, Personal Pearl, and Backfield for your terminal and printer. This takes ten minutes or so, and is fully automatic. When that's done, you can set up your printer in a way similar to what we did with the terminal.

-- (*) --

Checkpoint C

- o The MD-11 passed its memory test; the installation procedure went along with no problems; and now the Co-Pilot Main Menu is on your screen. This menu is shown on the next page, so you can be sure you've got your bearings.

=====

C O P I L O T M A I N M E N U

This menu is your copilot through the CP/M operating system. To perform these functions, just type the appropriate number after the prompt below, then follow the instructions given.

1	NewWord	Word Processing
2	SuperCalc	Financial Analysis
3	Correct-It	Spelling Checker / Corrector
4	Personal Pearl	Data Base Manager
5	Quest	Bookkeeper System
6	Backfield	Hard disk backup programs
7	MBASIC	Microsoft BASIC
8	BaZic	North Star Compatible BASIC
9	PARK	Hard disk head parking utility
U	Utility menu	
ESC	Exit to CP/M	

Enter your selection: []

=====

The MD-11 is now ready to go to work for you. If you want to press some keys and put it through its paces, go ahead. However, be aware that if you're using a serial printer you won't be able to print anything yet. Those of you with parallel or Centronics printers are finished with this whole "wire-up 'n fire-up" business. Congrats.

If You Didn't Make It to Checkpoint C . . .

Two things might have occurred. Either the hard disk couldn't be accessed at all, or it failed the VERIFY test that's run as part of the installation.

In either case, you have a little work to do:

NOTE: DON'T PERFORM THESE STEPS UNLESS YOU HAD INSURMOUNTABLE PROBLEMS BETWEEN CHECKPOINTS B AND C. IF YOU MADE IT AS FAR AS INSTALLING NEWWORD, THIS IS NOT FOR YOU!

1. Locate the diskette that came with the MD-11 labelled "CP/M Distribution Diskette #1". Insert it in the floppy drive and close the latch. See Appendix B if you don't know how to insert diskettes.
2. Without turning anything off, press the RESET button on the front of the MD-11 (the little button on the lower right corner with the light in it).
3. When you see "Do you want to boot from the floppy disk? (Y/N)", type Y. Then follow the instructions that appear on the screen for reformatting the hard disk and recopying the software onto the hard disk from the other diskettes you received.
4. Keep following the onscreen instructions until the Co-Pilot Main Menu appears on the screen.

Setting Up Serial Printers

Owners of parallel printers should ignore this section.

Okay. Let's assume you've made it to the Co-Pilot Main Menu. The MD-11 comes from the factory under the impression that you'll be using a parallel printer. So before you can print anything, you need to set the record straight.

This process is quite similar to setting up a terminal. However, it's a bit more interesting, as it gives you your first experience with using the CP/M operating system directly (as opposed to using it through the menu system).

Before proceeding, get your printer manual - or call your dealer - and extract this information: how to set the printer to 1200 baud, and whether it can handle XON/XOFF (software) handshaking. In some rare cases, your printer might not work at 1200 baud; it may be stuck at 300 or 2400. If so, make a note of this.

Ready?

1. At the Co-Pilot Main Menu, press the ESC (escape) key on your keyboard. After a message or two, you'll see "A>", with the cursor to the right.
2. Type setup and press the RETURN key.
3. You should be looking at something like this:

=====

This program allows you to change the operating characteristics of your Micro Decision. The changes can be made temporarily or permanently.

- | | |
|---|---|
| A) Terminal speed
9600 baud | C) Printer / modem speed
1200 baud |
| B) Printer connection
CENTRONICS PARALLEL | D) Printer / modem protocol
HARDWARE HANDSHAKING ON PIN 20 |
| E) Make temporary changes effective immediately | |
| F) Save changes on disk for use after next boot | |
| ESC) Quit without making any further changes | |

Selection: []

=====

You'll be interested in all of the options B through F.

1. First type B. The Printer Connection display changes to PRINTER / MODEM, which is where you've attached your serial printer cable.

2. IF your printer is stuck at some baud rate other than 1200, press C until its baud rate is shown under the PRINTER / MODEM SPEED line. If you accidentally pass the number you want, keep tapping C until it comes around again.
3. IF your printer can use XON/XOFF handshaking, press D and watch HARDWARE etc. change to XON/XOFF.
4. When all of the items are set up right, press E, then F, and finally ESC. You should see "A>" again.
5. Type pilot go and press RETURN. Now you're back at the Main Menu.

The only thing that would prevent your printer from working now (assuming it's in good shape) is a defective or improperly wired cable.

Keep in mind that most printers require that they have paper and ribbon (and sometimes printwheel) installed before they'll work. They also probably have an "on-line" switch that must be turned ON.

Finally, if the printer prints but it's "garbage," you most likely have a baud rate mismatch. Run SETUP again when you figure out the right speed. If it prints fine for a while and then goes haywire, you should try running SETUP again, this time changing the protocol to HARDWARE or XON/XOFF, whichever it currently is not.

-- (*) --

Thus ends the saga of setting up the computer. Perhaps a bit more involved than a video game, but not much. You may now play around with your programs, which are introduced in the next chapter.

CHAPTER 2

----- USING YOUR MD-11 FOR THE FIRST TIME

This chapter introduces all of the functions that are available through your Co-Pilot menus. Pay special attention to the PARK command (DON'T turn the MD-11 off until you've read about PARK), and the need for backing up your files.

A word to the wise for those who haven't heard this about computers yet: If you unplug a computer, or turn it off, or even press the RESET button while a program is running, the computer forgets everything it was doing. Therefore you run the risk of losing data when this happens. The programs themselves, however, should suffer no damage.

Contrary to this warning, if you get completely stuck or lost in the exercises that follow, go ahead and press the RESET button, but DON'T TURN THE MD-11 OFF (since you won't have PARKed it). Resetting will be alright because you won't be doing anything that risks data.

It takes a good while to try everything in this chapter. If you want to stop in the middle, select PARK from the Co-Pilot Main Menu before turning the MD-11 off.

REMEMBER. . . .

PARK!
PARK!
PARK!
PARK!
PARK!
PARK!
PARK!
PARK!
PARK!

MAKE IT A HABIT.

The Main Menu, Revisited

=====

C O P I L O T M A I N M E N U

This menu is your copilot through the CP/M operating system. To perform these functions, just type the appropriate number after the prompt below, then follow the instructions given.

1	NewWord	Word Processing
2	SuperCalc	Financial Analysis
3	Correct-It	Spelling Checker / Corrector
4	Personal Pearl	Data Base Manager
5	Quest	Bookkeeper System
6	Backfield	Hard disk backup programs
7	MBASIC	Microsoft BASIC
8	BaZic	North Star Compatible BASIC
9	PARK	Hard disk head parking utility
U	Utility menu	
ESC	Exit to CP/M	

Enter your selection: []

=====

As you can see, selections 1 through 8 are to run the software programs which came with your system. Selection 9 PARKs your disk heads so you can safely turn the MD-11 off. Typing the letter U will give you the Utility Menu. ESC, located on the upper left of your keyboard, will take you out of the menu system so you can enter CP/M commands directly. Let's look at these selections more closely.

A Sampling of the Software

This exercise has two purposes: to demonstrate how to run your software directly from the Main Menu, and to check that all software has been properly installed on your hard disk. We recommend you take this tour to get to know the lay of the land.

If you find that some of your programs are not starting up right, call your dealer.

NOTE: Your software manuals have a tendency to assume you're using a floppy-only computer. For example, page 13 of Personal Pearl tells you to "insert your PROGRAM and DATA disk into drive B." NewWord has you logging onto drive B on page 5-2 of the "Do It Yourself."

We'll forget that stuff. Everything you need, data and programs, is all on drive A, the hard disk.

You can change the logged drive and user number at the NewWord Opening Menu nonetheless, but there's no need for you to do so yet.

NewWord

NewWord is your wordprocessing program. For most people, this is by far the most frequently used program. You can use it to generate any text, such as memos, books, form letters, and computer programs.

NewWord has a fairly good manual, perhaps the best among the set you received. Note, however, that you should disregard Chapter 2 of that book. It gives lengthy installation instructions that don't apply to the MD-11.

- o Select NewWord from the Main Menu by typing 1. The next thing you see is:

```
-----  
-----  
1.  
  
====  
-----  
2.  
  
====  
-----  
3.  
  
====  
-----  
-----
```

You have three NewWord filing drawers available. They correspond to User Areas 1, 2, and 3. Files you create will go in the drawer you open now. To work with an existing file, first select the drawer which contains the file.

- {1} Open drawer 1
- {2} Open drawer 2
- {3} Open drawer 3

- {D} Display a drawer's contents
- {ESC} Return to Main Menu

Select 1, 2, 3, or D: []

This screen was not shown by NewWord. NewWord hasn't started yet. This is still part of Co-Pilot. Here's what it means:

Your hard disk can hold so many files, there has to be some method for grouping them together in a logical way. CP/M 3.0 does this by assigning every file a user number. It can range from 0 to 15. One user number is "current," or in effect, at any given time.

Whenever you create a file (say, by typing a recipe with NewWord), the file is assigned the user number that is currently in effect. Co-Pilot uses this feature by setting the current user number before starting NewWord. Therefore any file you create will have user number 1, 2, or 3 -- that is, it goes into whichever "drawer" you pick before proceeding. Later, if you want to revise or print the file, you need to pick the same drawer that you did when you created the file.

The rest of the user numbers (4 - 15) are assigned to the other programs. SuperCalc, Personal Pearl, and Quest each have three of their own; BASIC and BaZic have one each; one (#15) is reserved for you to use as you please after you learn about CP/M. User number 0 is a special case: it holds all of your programs.

- o Try pressing D, to look at a directory. Then pick drawer #1's directory by typing 1.
- o You should see three file names. These are sample files used in training exercises for NewWord. They were given user number 1 as part of the NewWord installation procedure.
- o Press any key to get back to the NewWord filing cabinet. Now type 1 to "open" drawer 1.
- o Momentarily, you're presented NewWord's Opening Menu. If you would like to see whether your printer's hooked up and adjusted right, type P. Then type SAMPLE1.DOC and press the ESC key. (The name doesn't need to be in upper case.)
- o If your printer is set up right and is on-line, it should begin printing. If not, and you can't figure out what to do, press the RESET button on the front of the MD-11. In this case nothing bad will happen; you'll just have to start over.
- o If the printout worked, type X when it's finished. You'll exit from NewWord back to the Co-Pilot Main Menu.

We leave it to you and the NewWord manual to proceed from here. Just remember that you have to "save" a file before you can print it or go back and change it. Saving is a simple three-keystroke command, covered at length in the NewWord manual.

SuperCalc

This is your "electronic spreadsheet." It lets you set up small (or huge) tables of numbers and objects, among which you define mathematical relationships. Then you can change one number, and immediately see how that impacts everything else. For example, you could plan an investment strategy with certain assumptions about, say, T-bill interest rates. Then you can change the rate and see how much better utility stocks look.

- o At the Co-Pilot Main Menu, type 2. The filing cabinet (explained under NewWord) takes over, but this time the drawers correspond to different user numbers (4, 5, and 6). Pick any drawer.
- o Now SuperCalc is in control. Its first screen serves no particular purpose, other than making sure you really want to run SuperCalc. Press RETURN to keep going.
- o And zap! What you see now is the upper left corner of a blank spreadsheet that is much too large to fit on your screen all at once. You're ready to begin at page 3-1 of the SuperCalc manual.
- o But now may not be the time for an in-depth look at SuperCalc. There's much more ground to cover, so type /q for "quit" and verify with a Y. Back to Co-Pilot.

Correct-It

Correct-It finds and fixes spelling errors in files you created with NewWord. It is not totally automatic by any means, but is still quite easy to use. Instructions for it are contained in the latter half of the pamphlet "Special Instructions for NewWord and Correct-It."

- o At the Co-Pilot Main Menu, type 3. You'll see those familiar filing drawers once again. This time they are the same user numbers as for NewWord, since you'll be correcting NewWord documents. Pick the number for the same drawer as you used when you typed the file with NewWord (which you haven't done. So for the sake of practice, pick any drawer.)

- o Then you see:

=====

Correct-It: Morrow Designs Spelling Checker V1. 01
Licensed from Aspen Software Co. (c) (p) 1982

Enter name of file to check:

=====

- o This is a good time to show you a little trick. Since there's no file to correct yet, you must exit by typing "control-C". This means: Hold down the key labelled CTRL on your keyboard, and while holding it down, tap the C key. Thus you use the CTRL key like a SHIFT key on a typewriter. You'll get to know the CTRL key very well as the years go by.

Personal Pearl

Personal Pearl is a "relational data base management system," which is a fancy way of saying it stores a seemingly infinite array of little facts. Then at your command, it digs out the ones you want, sifting and sorting in predefined ways, finally giving you a report according to your design. For example, you could ask Pearl to print a list of all the people who owe you money, sorted in reverse alphabetical order by middle initial.

- o At the Co-Pilot Main Menu, type 4 for Pearl. Again you see the file cabinet (described under NewWord); this time the drawers correspond to user numbers 7, 8, and 9. Pick a drawer, any drawer.
- o Another menu! You are still in the Co-Pilot system. This is a list of the various modules that make up Pearl. Select 1, for the "Welcome" program. You need to remember what your screen said back at installation time about which terminal to select when running Welcome.
- o After a pause, a list of terminals appears. Pearl has finally taken over. Picking a terminal is required only with Welcome, not with the other modules (Design Forms, etc.).

- o If you've forgotten what your screen told you about your terminal, try ADM-3A or Micro Decision Level I. (Should your terminal lock up a screen or two down the road, feel free to RESET and try something else.)
- o At the "Demonstrate or Personalize" option, pick D. You already personalized Pearl during the installation. The demonstration is self-explanatory. When you've had enough, press the ESC key to back up until you finally return to the Co-Pilot Main Menu.

Quest

NOTE: Your hard disk does NOT come with Quest already loaded. This is because it requires a lot of disk space and not everyone will want to use it. You load it onto the hard disk from diskettes yourself with the Utility Menu option "Load Quest Bookkeeper." This option is described later in this chapter.

Quest is a bookkeeping system for Accounts Receivable, Cash Disbursements, and General Ledger. It too has a built-in demo program that we'll run in this exercise.

- o At the Co-Pilot Main Menu, type 5. Here comes that filing cabinet again! This time the user numbers are 10, 11, and 12. Pick a drawer.
- o The first thing you must do is specify a date in the format MMDDYY (that is, August 4, 1984 is 080484).
- o Then type 98 and RETURN for function 98, demonstration.
- o When you're ready to quit, type \2. That's the "backslash" key, not a regular slash. Then RETURN.
- o Back at the Quest starting menu, type 99 and RETURN for exiting back to Co-Pilot.

The Backfield

Congratulations! You have discovered one of the two extremely important maintenance programs for your hard disk (the other being PARK). Backfield is actually a set

of programs that copy files from your hard disk onto floppies, and back again. You should read about its options in the Backfield manual as soon as possible.

The value of such programs is the insurance they provide against lost data, should anything happen to your hard disk. In the old days of floppies, if a diskette was scratched or exposed to magnetism, you might lose 400K of data. With a hard disk, you stand to lose twenty times that much!

Backing up important files was crucial in floppy times, too. But it was easy to copy a floppy; it took about 5 minutes. Backing up a hard disk has traditionally been time-consuming and painfully tedious. That is what's so nice about Backfield: it's fast and convenient. So you have no excuses for not using it.

In this section we're going to make the first full backup of your hard disk. This will be the same process you should go through once every one or two weeks. There is a shorter, faster process you should use every day, which we won't cover here.

You'll need seven blank soft-sectored diskettes. Be sure they're certified for double-sided and double-density use.

- o At the Co-Pilot Main Menu, type 6. You'll proceed to the Backfield Options Menu.
- o Select item 1, to format your diskettes. The screen leads you through this. Go on to the next step after all seven diskettes have been formatted. (Note: if a diskette fails the verify portion of formatting, throw it away or return it to the dealer.) You'll be able to recycle these diskettes with your next full backup, so this step won't be needed each time.
- o Now select item 3 - Backup the entire hard disk.
- o The next thing you have to type is the "date or other ID code." The date will be fine. Type it in the format MM/DD/YY. (The Backfield manual lists the restrictions on ID codes.) Press RETURN.

- o The Backfield module "FULLBACK" tells you when to change diskettes and how to label them. We recommend you label them: Full Backup, (Date), V. 001. Add 1 to the volume number as you proceed through your stack of diskettes. (You may not really need all seven.)
- o When you're done, you are automatically returned to Co-Pilot.

Now that wasn't so bad. And you only have to do this once in a while. EVERY DAY, however, you should select Backfield item #4 - Backup only those files that have changed since the last daily or weekly backup. You should only need one (formatted) diskette for this; it takes much less time; and you can use the same diskette each day. Don't use any of the diskettes that you just filled with the full backup.

Store all of your backup diskettes in a very safe place. You may never need them. You may never need your Homeowner's insurance, either. But then again . . .

BASIC and BAZIC

We're not going to use these right now. You have enough to think about without learning how to program too. But they're there if you're interested. These have only one user number dedicated to each of them, so you won't see the file cabinet screen.

PARK

You wouldn't just hop out of your car and let it roll off to wherever the laws of physics led it, would you? (Not unless you're trying to stash a body in some swamp, anyway.)

Just like you park your car when you're done with it, you need to PARK your computer.

What really goes on here is this: your disk heads are not supposed to be in actual contact with the spinning disk. That would damage the magnetic surface of the disk and clog the heads. Instead, they ride on a thin cushion of air just above the surface. That air cushion is created by the spinning of the disk, so when the disk stops, the heads fall into contact with the disk (the nefarious "head crash").

Disk manufacturers supply a special part of the disk called the "parking area." Here the heads can safely land without damage to them or the disk. You need to be sure the heads are positioned over the parking area before you interrupt power to the computer. This is what the PARK program does.

```
*****
*
*   NOTE:  ALWAYS PARK YOUR HEADS BEFORE TURNING *
*   OFF OR UNPLUGGING THE MD-11. ALWAYS. AND TO BE *
*   REALLY SAFE, PARK BEFORE TURNING YOUR PRINTER *
*   OR TERMINAL OFF, TOO. *
*
*****
```

In fact, just for the heck of it, why don't you do it right now?

- o At the Co-Pilot Main Menu, type 9.
- o When you see "You can now turn your system's power off" (or equivalent), you're safe.
- o Press the RESET button - or turn the power switch off and back on, to get back to the Co-Pilot Main Menu.

ESC: Exit to CP/M

This means: press the ESCape key, and the man behind the curtain will be revealed!

If you're already a computer whiz who knows your way around the CP/M operating system, well, get out there and do some exploring. The rest of you should follow these instructions:

- o Press the ESC key to break out of the menu system.
- o You'll see "A>". This is the CP/M prompt, that means the MD-11 is ready and waiting for any valid CP/M command. "Valid" is the tricky part: CP/M is extremely picky about the commands you can enter and how they must be typed. Hence the Menus, to get around the frustration this can cause beginners.

- o Try this most basic of commands. Type `dirs` and press RETURN. Keep pressing RETURN to see all the pages of files on your hard disk. Are you sufficiently impressed? And you haven't even begun to fill the disk up with your own stuff.
- o When the directory listing is done and `A>` returns to your screen, type `pilot go` and press RETURN. This takes you back into the menus.

The Utility Menu: Your Tool Box

Let's take a look at the Co-Pilot Utility Menu now by typing `U` at the Main Menu. You should see:

=====

C O P I L O T U T I L I T Y M E N U

This menu allows you to perform a number of everyday utility functions. Simply type the number next to the function you desire.

- 1 Display a directory
- 2 View or Print a file
- 3 Copy a file or files
- 4 Format a diskette
- 5 Check disk space and file size
- 6 Execute a CP/M command
- 7 Rename or erase a file
- 8 Fundamental training in CP/M
- 9 Load Quest Bookkeeper
- ESC Return to Main Menu

Enter your selection: []

=====

The Utility Menu lets you do certain household file chores without any knowledge of CP/M. Later on, when you learn enough about CP/M, you may never use this menu. But until then, it will be a good friend.

Display a Directory

A directory is a list of the files on a disk. This selection is the same as typing `dir [full]` at the `A>` prompt.

- o Go ahead and type `l`. When you're asked for a user number, answer `0` and press RETURN.
- o This is the same list of files you saw earlier when you typed `"dirs"` at the `A>` prompt. But now the format is different; there's more information. For example:

```
=====
BACKUP  COM   4k   23   Sys RW
=====
```

Briefly, this means: You have a file named `BACKUP.-COM` that has been allocated 4k (4000) bytes of space on the hard disk. It consists of 23 records that are 128 bytes long each. (23 times 128 is substantially less than 4000, but hard disk space is allocated in 4k chunks; therefore a file 1 byte long will still show 4k in its "Bytes" column.) Its attributes are `Sys` for "system" and `RW` for "read and write."

You can find out more about attributes under the `SET` command with the "Fundamental Training in CP/M" option. This is the last selection on the Co-Pilot Utility Menu, and we'll talk about it in a minute.

View or Print a File

Suppose you've been working with `NewWord` for some time. One of your file drawers now has files in it named `LETTER.A`, `LETTER.2`, `LET`, `25LET`, and `LETR`. You've had a nervous breakdown and now you simply can't remember which file is which. (One problem is your less than wonderful way of naming files.)

You could run `NewWord` and scan through each of these files, but there's a faster way: the `CP/M type` command. This command scrolls a text file up your screen so you can scan it. It pauses after each screenful and waits for you to press a key before showing the next screenful.

That's all well and good. What we didn't say is that "View or Print a File" on the Utility Menu doesn't use the type command, because of problems between PILOT and the nature of type. It uses a CP/M command called pip instead. (pip is also used by the "Copy a File or Files" option.)

Let's give this a try:

- o At the Co-Pilot Utility Menu, type 2. When asked for the file's name, type practice.doc and press RETURN.
- o For user number, type 1 and RETURN.

Now for a brief lesson in CP/M Control key codes. The file you are going to look at (one of NewWord's practice documents) is about to whiz up your screen faster than even Evelyn Wood could handle. This is a weakness of the pip program, as opposed to type, which stops after each screenful automatically.

To freeze to scrolling, use CONTROL-S. That is, hold down the CTRL key and tap the S. To resume the scrolling, use CONTROL-Q. To stop looking at the file before it is finished, type CONTROL-C. Got it?

- o When asked "screen or printer," type S. Keep your eyes on the screen and your fingers on the keys.

If you want to send a file to your printer as well, you'd type P instead of S above. But be aware that your printer has to be ready: power on, on-line, paper & ribbon in place, cable connected . . . all the steps we covered in the first chapter. Trying to print when the printer isn't ready could bring everything to a halt. But don't fret. Just press the MD-11's RESET button and start over. DON'T turn the MD-11 off, since you haven't PARKed it!

Copy a File or Files

There is many a use for this handy fellow. For example, Personal Pearl lets you print reports into a disk file instead of sending them out to the printer. Suppose you want to edit the report to change its format or fix typos. Or maybe you want to include it as part of a larger document. To do this, you need to copy the Pearl output file from its file drawer into one of NewWord's file drawers, so you can get to it with NewWord.

Other examples: copying new software from a floppy onto the hard disk. Backing up a file or two onto floppies from the hard disk. Rearranging the distribution of files among the 16 user numbers (which is really what the example in the first paragraph is doing).

To try this function, format a blank diskette first (see below) and come back when that's done.

- o Insert the formatted diskette into the floppy drive and close the latch.
- o At the Co-Pilot Utility Menu, type 3.
- o For the "original's" name, type `pip.com` and RETURN. Then give 0 as its user number.
- o For the copy's name, type `B:pip.com` and RETURN. The letter B and colon say "put the copy on drive B, that is, the floppy drive." Give 0 as its user number also.
- o Co-Pilot makes sure you've typed what you meant to type and gives you a chance to change it. If the last line on the screen reads "You want to copy `pip.com` in user 0 to `B:pip.com` in user 0. Is that right?", then all is well. Type Y.
- o When the copy is finished, you can pick option 1 to look at the floppy's directory, and lo! you'll find `pip.com` on a formerly blank diskette. Good work.

Incidentally, what you've done here is copy the copy program. You've pipped pip. Once you've learned your way around CP/M, pip will probably be one of your most common commands.

Format a Diskette

Diskettes have to be formatted before you can store anything on them. Formatting sets up a circular grid in the magnetic surface of the floppy that serves as a sort of road map to files. The MD-11 has a program `format.com` written by Morrow specifically for its diskettes.

Just in case you didn't know, you can recycle old diskettes by re-formatting them. BUT - everything on the diskette will be gone after formatting! So never reformat a diskette unless the information on it is useless or has been copied elsewhere.

You've already formatted diskettes if you followed the directions for backing up the hard disk under "Backfield." In case you didn't (shame on you), let's go through it:

- o Find a blank diskette. Surely your dealer didn't let you leave the store without buying a box.
- o Insert it in the floppy drive and close the latch.
- o At the Co-Pilot Utility Menu, type 4. Follow the instructions on the screen. Pick 1 for normal, double-sided diskettes.
- o That's all there is to formatting.

If you run `format` directly from CP/M, you'll have more questions to answer, such as drive to format ("B" for floppies) and single vs. double sided. The MD-11 and MD-3 computers can read single or double-sided diskettes, but you obviously get twice as much storage space with double-sided diskettes. The MD-2 computer can read only single-sided diskettes; so if you want to share a file with an MD-2, you'd have picked 2 above instead of 1.

Check Space and File Size

Even though your hard disk can hold about 5,000 pages worth of text, numbers, and programs, it will get full eventually. Faster than you think. So you need to keep an eye on it. It is rather upsetting to have typed twenty inspired pages, only to find that you can't save them on the disk because there's no room left.

- o At the Co-Pilot Utility Menu, type 5.
- o Since we want to check the space left on the hard disk, select 3 from the next list that appears.

Of the lines that follow, the one of interest reads:

```
A: RW   Space: #####
```

The "RW" means that you can read from the disk and write to it as well. By contrast, disks can be set as "read only" as a protection against accidental changes or deletions. The "#####" should really be some number on your screen, like 7,800k. This means you still have room for almost 8 million characters ("k" signifies 1,000 bytes). So take a deep breath and relax.

What do you do when the hard disk starts getting dangerously full? And how full is dangerous? Well, when you have only 1000k (1 megabyte) left, you better start erasing unneeded files. Dormant files that should be saved would be copied onto floppies and then erased. Be aware that the fuller your hard disk becomes, the longer it takes to find and transfer information. Try to maintain a lean and mean machine.

You probably noticed that the "Check Space and File Size" option lets you keep track of how full a floppy is getting, too. You could use this to make sure a file will fit on a floppy before attempting to move it there. You'd also check the file's size with this same option. Look in the "Bytes" column of the resulting report.

Execute a CP/M Command

This option is on the Utility Menu for people who want to stick their big toes in the pond to check how cold the water is. (It's really rather tepid.)

For those of you who have trouble with metaphors, this means that you can experiment with entering CP/M commands yourself. And that it's not too hard after all. So dive on in:

- o At the Co-Pilot Utility Menu, type 6.
- o Where it asks COMMAND?, type hdhdh and RETURN.
- o CP/M says "HDHDH?". This means, basically, "What?"

You have typed a nonexistent command. The response of HDHDH? is the harsh punishment inflicted on you by CP/M for wasting its time with nonsense. The point is, CP/M is really rather stupid; it isn't bothered in the least if you enter a command incorrectly; it just twiddles its thumbs and doesn't do a thing - or, worse, sends you some mysterious error message. And it will happily continue to do so all day long, with infinite forbearance, until you smash the computer.

So you see, you have nothing to be anxious about but anxiety itself.

- o Type CONTROL-C to continue. By now you should know that this involves holding down the CTRL key while tapping C.
- o We'll do something real this time. Pick 6 again.
- o At COMMAND?, type user 1 and RETURN.
- o When you see 1A>, type dir and RETURN.
- o When 1A> shows again, type user 0 and RETURN. We'll return to the menus in just a minute.

If you're highly analytical, you'll have learned a lot from this little exercise. First you changed the current user number from zero to 1. The "1A" signifies this; it also signifies that drive A (the hard disk) is the current drive.

Then you displayed the directory of drive A, user 1. These are the practice documents for NewWord. Has a light bulb flashed on in your brain? User 1 is the same as NewWord's "file drawer" number 1, just as user 4 is LogiCalc's file drawer number 1.

Finally, you switched the current user number back to 0. When a CP/M prompt like A> appears with no number in it, that means zero is the current number. You'll never see "0A>".

- o We're going to run one more command that's crucial to the success of the exercise in "Erase or Rename a File" below. First, make sure the diskette with pip.com on it is in the floppy drive. You made the diskette back under "Copy a File or Files."
- o At A>, type: set B: pip.com [rw] and press RETURN. You should get a message confirming the operation. If you get an error message instead, check your typing and try again.
- o Press CONTROL-C to get back to the menus. By now you should know this means tap C while holding down the CTRL key.

The "Fundamental Training in CP/M" option on the Utility Menu introduces you to most of the common CP/M commands. You might also read the CP/M User's Guide that came with the MD-11 for further information (just this one book - not the whole set of five).

Rename or Erase a File

There's no real significance in the fact that these two commands are on the same option; they're both important, but we didn't want to clutter the menu with too many selection numbers.

It's obvious why you'd want to erase a file: to make room when you don't need it anymore. But why rename one? Several possibilities:

1. You gave a file an unwieldy name to begin with, like "REELYBAD.NAM". Typing it frequently becomes a chore, so you rename it to "BAD".
2. You want to edit one of NewWord's ".BAK" files. (You'll understand this when the time comes.)
3. You want to copy a file onto the hard disk, but there's already a valuable file on the disk with the same name as the one you want to copy. Unless you rename the file that's already on the disk, it will be erased when the new file is copied.

We're going to rename a file, and then erase it. With these instructions you'll need the diskette with pip.com on it that you made earlier under "Copy a File or Files." This is only because we don't want to mess around with the hard disk yet. You also need to have followed the final steps in the last exercise, "Execute a CP/M command."

- o Insert the diskette with pip.com on it into the drive and close the latch.
- o At the Co-Pilot Utility Menu, type 7.
- o Then pick 2 to Rename a File. Give B: pip.com as the old name of the file. Before you press RETURN:

***NOTE: MAKE SURE THAT "B:" IS ***
THE FIRST PART OF YOUR RESPONSE!

Type 0 and RETURN as its user number. Then type newname and RETURN as the new name (such a staggering imagination!).

- o When you've checked that everything was typed right - especially the "B:" part - type Y to continue.

You can now use Utility Option 1 to look at the floppy's directory. If "newname" is there, you know all you need to know about renaming files.

Now we'll get rid of newname altogether.

- o Pick 7 from the Utility Menu again.
- o This time, select 1 to Erase a File.
- o Type B:newname as the file to erase, with user number 0. Verify with Y.

If you look at the floppy's directory now, you won't see much. Farewell forever, Mr. Newname.

Fundamental Training in CP/M

This is your best place to start learning about CP/M. It is an "on-line tutorial," which means nothing else than basic information that appears on your screen.

There really isn't anything to explain about it. Go ahead and give it a shot, unless you're just entirely beat. It will always be there when you're ready.

Whew!

That's a lot of information to absorb in one session. But think of it: you've travelled every highway and one-lane dirt road that the Co-Pilot Menu System covers.

A word of encouragement is in order. When you begin studying the use of NewWord, Quest, and the rest, you'll inevitably become frustrated and confused for a while. There are dozens of keystrokes to learn; many unforgivingly precise procedures; and the manuals can be tough.

Take heart. That phase lasts a couple of weeks at most. Then you start getting confident, even cocky. And so you've arrived: a computer-user; a Morrowmaniac; a Citizen Of The Twenty-First Century.

And probably the first one on your block with a hard disk, to boot.

CHAPTER 3

----- ABOUT THE PROGRAMS IN USER 0

User number 0 of your hard disk holds a vast library of utilities, application programs, and other files. If you'd like to see its directory, escape to CP/M from the Co-Pilot Main Menu and type:

```
dir [full]
```

The files are listed in no particular order, and they're not grouped in any significant way. (Type pilot go to get back to the menu.)

Many of these files are standard CP/M utilities that are used mainly by programmers. They are documented in your set of CP/M manuals.

The second category of files are your application programs. NewWord, for example, has five files devoted to it: NWU.COM is the uninstalled main NewWord program; NW.COM is its installed version; NW.OVR has additional pieces of the program; NWMSG.S.OVR holds all of the messages that NewWord puts on your screen; and NWINSTAL.COM is the NewWord installation program.

Beyond your CP/M and application programs, there is a handful of other special-purpose programs developed by Morrow for your convenience. This section focuses on those programs. They're described briefly below. After that we'll look at them in more detail.

- BACKUP.COM - Duplicates floppies by copying them into a temporary hard disk file, and writing them back out.
- COPYSYS.COM - Copies part of the CP/M operating system onto the "system tracks" of the hard disk or a floppy.
- FOREIGN.COM - Allows you to read and write data on diskettes of certain non-Morrow formats, as well as running programs from and copying such foreign diskettes.

- FORMAT.COM - Normally formats floppy disks, but can format your hard disk too if necessary.
- INIT.COM - Finds out what kind of terminal you're using, helping to install your software easily.
- LOAD.COM - Restores the initial contents of the hard disk from the distribution diskettes.
- PARK.COM - Moves the hard disk head to a safe place for turning off the computer.
- PILOT.COM - Interprets PILOT programs like the Co-Pilot Menu System.
- PROFILE.SUB - A sequence of routine commands that the MD-11 executes automatically when you reset.
- SETUP.COM - Controls the baud rates at which the MD-11 talks to your terminal, modem, and serial printer; also sets printer protocol and whether it's serial or parallel.
- VERIFILE.COM - Makes sure your hard disk survived shipment to its destination.

Now we'll look more closely at these utilities, in the order of their importance to the average user. When you see "CP/M prompt," this refers to the "A>" that you see when you escape from the menu system.

PARK.COM

PARK is available on the Co-Pilot Main Menu, but you can also run it from the CP/M prompt by typing "park". This is an extremely important program for the safety of your hard disk. It moves the disk's read/write heads to the parking area of the disk, where they can't damage data by knocking against the disk or making an accidental write when the power is turned off.

NOTE: You should run PARK every time you turn your computer off! If you want to move the computer and it's off already, and you're not sure whether you parked the heads, turn it back on and run PARK just to be sure.

FORMAT.COM

FORMAT appears in the menus twice, in one form or another: on the Utility Menu, and on the Backfield Options Menu. When you run it this way, both of its options are automatically specified.

NOTE: Formatting a disk erases everything on the disk. NEVER format your hard disk unless it's hopelessly damaged, and then only after you've backed up what you can onto floppies. You can recycle old diskettes by reformatting them. This is preferable to erasing them with ERA because FORMAT verifies that the magnetic material is still in good shape.

When you run FORMAT from the CP/M prompt, you have to tell it which drive has the disk to be formatted, and whether it should be formatted as single or double-sided. If you specify drive A: (the hard disk), you get a much-justified warning about the dangers of reformatting the hard disk. So it's nigh impossible to reformat the hard disk by accident.

In the normal case of formatting a floppy, the command to enter at the CP/M prompt is:

```
format b d
```

In other words, format the diskette in drive B: as double-sided. The only time you'd format a single-sided diskette is if you wanted to use it on an MD-2 or older MD-1 model.

SETUP.COM

You won't need to run SETUP often. In fact, you may never need it, if your system matches SETUP's default values and you don't change your hardware.

SETUP determines a number of things about how the MD-11 communicates with its peripherals. It comes from the factory with these assumptions built-in, and these optional changes:

	<u>Initial value</u>	<u>Available options</u>
Terminal baud rate	9600	110 - 19200
Printer connection (LST: device)	CENTRONICS PARALLEL	PRINTER / MODEM (serial)
Printer/modem port baud rate	1200	110 - 19200
Printer/modem port protocol	HARDWARE HAND- SHAKING ON PIN 20	XON/XOFF

Thus if your terminal can be set to 9600 baud (almost certain), and you have a parallel printer, you don't need SETUP. If you have a serial printer, you will need to run SETUP before you can print anything. Appendix D covers this in excruciating detail.

PILOT.COM

This program is run whenever your Co-Pilot Menu system is alive. You also have to run PILOT before you can execute any of the commands you may have written in the PILOT language. PILOT.COM is the interpreter that stands between a PILOT-language program and CP/M. This may be a little confusing; some people think that the menu system is PILOT. The menu system is actually a set of programs, the main one being named MICRO.PIL.

If you want to run a PILOT program that you've written (named, with inspiration, PROGRAM.PIL), your command would be:

PILOT PROGRAM

This tells CP/M to run PILOT.COM, and then PILOT.COM runs PROGRAM.PIL. The ".PIL" ending isn't needed in the command.

Morrow has produced a whole manual dedicated to the PILOT language, so let's move on.

PROFILE.SUB

You run this "submit" file every time you do a cold boot, that is, every time you turn the computer's power on or press the RESET button. "PROFILE.SUB" is a very significant name. CP/M looks for a file of that name on drive A: in user 0 every time it wakes up, and if it finds one there, it goes ahead and runs whatever commands it finds in the file. If it doesn't find a file of that name, it just displays the system prompt and waits for your commands.

(Submit files are text files that can be generated with any text editor, such as NewWord. They consist of a sequence of normal CP/M commands. Thus they let you do a whole string of things with a single SUBMIT command. See the CP/M User's Guide for more on SUBMIT.)

Your MD-11 comes from the factory with PROFILE.SUB containing:

```
setdef *,a:[order=(com,sub)]
pilot go
```

This SETDEF command establishes the "search path" that CP/M follows when you type a command. Suppose you type "NW" at the CP/M prompt. This line tells CP/M to look first in the current drive (symbolized by *) and then on drive A:, if different, for a file called NW.COM or NW.SUB - and then run it.

The second line says "run the PILOT program GO.PIL." GO.PIL is a little program that in turn starts up your menu system. Thus the way to disable your menus is to erase this line from PROFILE.SUB.

Editing PROFILE.SUB is an interesting way to customize your MD-11's start-up behavior. For example, you could have it display a "Good Morning" message or better yet, "Don't forget to backup your files." However, unless you prefer a different search path, you should leave the SETDEF line alone.

You can use PROFILE.SUB to create a system that is dedicated to a particular application. For example, to set the MD-11 up to run NewWord only, use these as your second and third lines:

```
nw
submit profile
```

NewWord will run automatically; when you exit from NewWord, the whole thing starts over. Use this sort of loop with caution - when I tried this out, the only way I could get out of it was to erase these lines from PROFILE.SUB with NewWord after it had restarted for the umpteenth time.

BACKUP.COM

Like FORMAT, BACKUP is listed on both the Utility and Backfield menus. You use it to duplicate diskettes. The "source" diskette can be any Micro Decision diskette. The "destination" diskette must have been formatted, but need not be empty. However, anything on it won't be there for long.

BACKUP copies the source diskette track-by-track into a temporary file BACKUP.DSK in user 0 of the hard disk. Then it dumps this back out to the destination diskette and erases the temporary file. That's how you can duplicate diskettes with only one floppy drive.

You have the option of making multiple copies before BACKUP erases BACKUP.DSK, but you need to have all the formatted destination diskettes ready at hand.

Why, you may wonder, should you want to duplicate diskettes in the first place, when the diskettes are probably backups of the hard disk? For one thing, you may want to send copies of the fantastic new program you've written to all your friends with Micro Decisions. Or more likely, if you have a particularly valuable file, like Accounts Receivable, you may wish to have two backups of it: one for the office, one in a vault.

Since BACKUP copies track-by-track rather than file-by-file, a source diskette with CP/M in its system tracks will produce a bootable copy.

FOREIGN.COM

This program comes in very handy when you find some wonderful piece of CP/M software that's available in Xerox 820, Osborne, KayPro, or HP-125 (but not Morrow) format. Or if you have an IBM PC at work and you want to do some word processing on your MD-11 at home, you're in luck.

FOREIGN is run only from the CP/M prompt, so the first step in using it is to escape from the Co-Pilot Main Menu. Then type:

foreign

You'll be asked which drive to use as the foreign drive. You have three choices: B, C and D (A: being the hard disk). B is a good general response, unless you're doing something fancy like PIPping Morrow files from drive B: to a KayPro diskette in virtual drive C: and a Xerox diskette in virtual drive D:. If this concept of letters for more floppies than you've got sounds strange, read about virtual drives in Appendix A.

After specifying the drive, pick the letter of the format you want that drive to process. Put the foreign diskette in the drive, and treat it the same as a Micro Decision diskette.

After using the drive in its foreign mode, turn it back to good ol' Morrow by running FOREIGN again and specifying Morrow format for the same drive. (You don't really have to do this unless you need to read a Morrow floppy; the drive is returned to Morrow mode when you reset or turn off the computer.)

FOREIGN has a few limitations which will probably have changed by the time this is printed. At present, FOREIGN cannot format foreign diskettes. If your friend has an HP-125 and you want to give him a copy of one of your Morrow files (not a copyrighted program, of course), he'll have to format a diskette for you.

Also, FOREIGN has stricter limitations regarding IBM-PC diskettes. They must be CP/M-86 format (not PC-DOS), and you can read and write data on them, but not execute programs from them, since they would be written for a different operating system.

INIT.COM

NOTE: INIT.COM is not used with early releases of the MD-11, which assume you're using an MDT-60 or MT-70 terminal.

This is a very specialized program that is normally used only once in the life of your system. It presents a list of popular terminals, and asks you to select yours. Your choice determines two things: which of three general categories your terminal falls into ("Levels I, II, and III") and how the MD-11's CBIOS will translate generic terminal codes into the ones expected by your particular terminal.

Let's start at the beginning. The primary assumption is: Installing application software is a major hassle. Morrow wants its users not to have to install their software. How, then, to go about this?

Every application program has its own list of terminals that it presents as part of its installation. Maybe yours is there, maybe it's not. However, it's very likely that the Lear Siegler ADM-3A, ADM-31, and SOROC IQ-120 will be there. These three terminals are representative of the varying levels of intelligence being built into terminals these days (although most modern terminals are of the high-intelligence flavor).

Morrow gets around making you install your software by categorizing your terminal as Level I (ADM-3A), Level II (SOROC IQ-120), or Level 3 (ADM-31). The MD-11 either has software preinstalled for all of these terminals when you receive it, or installs it on the fly automatically.

Then the MD-11 takes care of translating any differences between the "representative" codes and your terminal's real codes. This explains why you're told that you should install any non-Morrow software for one of these three models. (If you could not find your terminal or a look-alike on INIT's menu, then you default to a Level 0 terminal, and you have to install some of your software after all.)

NOTE: The only time you would run INIT on your own is if you want to use a different model of terminal with the MD-11 after INIT was run the first time. After INIT, you should run MDINST.PIL (type `pilot mdinst`) to re-install the Morrow-supplied software automatically for your new terminal.

COPYSYS.COM

This is a standard CP/M utility, comparable to SYSGEN in earlier versions. We mention it here because there are some details that you should be aware of.

COPYSYS reads the reserved system tracks from a disk (which contain essential pieces of the operating system, specifically, a loader program) and copies them into memory; from there you can place them in a disk file or transfer them to the system tracks of a different disk. You do this in order to make a disk bootable, that is, so the computer can wake up from a cold start and groggily find its startup procedure in the reserved system tracks.

The average user has no need for such a program. If your hard disk ever becomes unbootable (for example, if lightning strikes while your disk head happens to be positioned over the hard disk's system tracks), you can boot from your CP/M Distribution Diskette #1, and COPYSYS will be performed automatically. Advanced users may want to use COPYSYS after customizing certain details of CP/M.

Beyond the system tracks, there is another file called CPM3.SYS that must be present on the hard disk. It holds the rest of the operating system.

This is all clean and simple if you're "COPYSYS'ing" from one hard disk to another. But this is not always the case. User 0 contains these files to help handle all variations: SYSLDR.COM, SYSLDRF.COM, CPM3.SYS, and CPM3F.SYS. All files mentioned so far are also on the CP/M Distribution Diskettes.

To make a bootable diskette, log onto the hard disk and type:

```
COPYSYS SYSLDRF.COM
...(Destination drive?) B: (Note the colon)
...(Any more?) N
PIP B:=CPM3F.SYS[R] (R flag for system files)
```

Now you can boot from this diskette, but it must be in the drive with the latch shut when you power up or reset the computer.

To restore the system tracks of the hard disk from the CP/M Distribution Diskette #1, boot from the diskette as described in the last paragraph. Then type:

```
COPYSYS SYSLDR.COM (no "F" this time)
...(Destination drive?) B:
...(Any more?) N
PIP B:=CPM3.SYS[R] (again, no "F")
```

LOAD.COM

Well, this program isn't really on your hard disk, for reasons that will be apparent when you see what it's for. It's on your CP/M Distribution Diskette #1.

LOAD is a utility that copies all of your Distribution Diskettes onto the hard disk, in case it was damaged in transit. It is the same program that's used at the factory to prepare your hard disk for use. LOAD is run automatically if you go through the procedure for repairing a hard disk that fails VERIFILE (see below).

What you see when LOAD is running (should you ever need to run it) are directions like "Insert your NewWord distribution diskette and press RETURN." Not particularly complex.

You would NOT use LOAD to rebuild a damaged hard disk that's had any data added to it. It's only for brand-new machines. To restore files to a damaged hard disk that's been in use, boot from your Backfield Working Diskette.

NOTE: Upon proofreading, the preceding paragraphs make it sound like your hard disk is a supremely delicate mechanism, bordering upon frail. Actually such devices are quite rugged, and seldom give any trouble. But the cost of that statistically remote failure can be devastating, if you have not made any backups. We stress the need for routine backups only because it seems to be a hard habit for some people to adopt. We hereby disavow any and all responsibility for the suffering incurred by those too lax to heed this warning.

VERIFILE.COM

One of the very first things your MD-11 does (or did) when you set it up is run VERIFILE to assess the condition of the data that was prerecorded on the hard disk. The program checks to see that every allocated sector is still readable. The outcome of VERIFILE decides whether you need to run LOAD.

Under normal circumstances, after this initial run you'll have no use for VERIFILE. However, suppose you use your MD-11 for a couple of years and then move to Walla Walla. You can run VERIFILE upon your arrival and see how badly the movers mistreated your treasured computer. (You did park the heads and pack it in its original container, didn't you?)

-- (*) --

In conclusion, if you don't get anything else out of this chapter, at least remember to PARK YOUR HEADS!

Also, when a section doesn't tell you exactly what to type for running the program directly from CP/M, that's because the program name is all you need to type. If it ends in .COM, you don't even need to type that part. For example, to run BACKUP from the A> prompt, simply type "backup" and press RETURN. Once you get used to its pickyness, CP/M isn't so bad after all.

CHAPTER 4

----- MD-11 QUESTIONS AND ANSWERS

-- (*) --

What are the restrictions on any file names I make up?

You'll be creating new files all the time, especially with NewWord, and you have to come up with names that balance the need for being descriptive against CP/M's need to keep them short.

Briefly, a file name has three parts, of which only the first is required:

- o The first name, which can be from 1 to 8 characters
- o A period
- o The last name, which can have up to three characters

If a last name is used, then the period must separate it from the first name. The last name is sometimes called the "file type" or "extension". By characters, we mean letters and numbers, and a few punctuation marks.

These are all valid file names:

5	F	5F	5F.DDD
LETTER	LETTER.684	LET.M	LETTOMOM
D.ATA	DA.TA	DAT.A	DATA.

These are NOT acceptable:

MYGREATNO.VEL	(too many characters before period)
MYGREATN.OVEL	(too many characters after period)
1/31/84	(slash character not permitted)

File names must be distinguishable from each other. No two files on the same disk, with the same user number, can have exactly the same name. At least one character must be different. However, since your hard disk has 16 user numbers, you could conceivably have 16 files on it with exactly the same names.

You should try to make your file names as descriptive of the file's contents as possible. For example, if you type many memos, you could construct the file name from the name of the person you're writing to, and the date, as in HOWARD.313.

The characters that you can't use in file names are:

< > = , | * ? & / \$ [] () . ; : \ + -

This implies that a few special characters are okay, as in NANCY'S.FIL.

-- (*) --

Would you please explain this business of disk drive letters?

You're always "logged onto" a certain disk drive. Nearly always this will be your hard disk. When you're working with CP/M directly (as opposed to through the menus), you'll see a prompt at the left side of the screen, like "A>" or maybe "15B>".

This prompt is telling you which drive and user number you're logged onto. (The first example above means drive A:, user 0; the other means drive B:, user 15. Those colons are conventional - you'll get used to them.)

So what does it mean to be logged onto a disk? It means that if you tell CP/M to run a program without telling it which disk to look on, it will look on the current drive, in the current user number. If the program isn't there, you either need to tell CP/M where to look explicitly, or else log onto the correct disk and user number. (There are some exceptions to this rule that go beyond this discussion.)

For example, if your prompt reads "A>", and you want to run a program called "pup" on drive B:, you can do two things: 1) run the program with the command B:pup, or 2) log onto drive B: first with B: and RETURN, and then pup.

So it seems rather simple: If a file is on a floppy, you'll be dealing with the B: drive; if it's on the hard disk, it's the A: drive. But these designations can be the other way around under certain circumstances.

Much depends on whether you've booted from a floppy. You'll not have done this unawares. To boot from the floppy when you turn on the MD-11, you must specifically instruct it to do so with a "Y" response to "Do you want to boot from the floppy?" And to have gotten that far, you must have pressed RESET (or switched power on) with a bootable floppy in the drive, with the latch shut.

So let's begin with the 99% probable case: you booted from the hard disk automatically.

- o Your A: drive is the whole 11 megabyte hard disk. You have 16 user numbers to play with, but if you're working through the Co-Pilot Menu system, this will be handled for you.
- o Your B: drive is the floppy. It has 380 kilobytes of space, and can also be organized in user numbers.
- o Drives C: and D: are "virtual" floppy drives. They refer to the same physical mechanism, but CP/M treats them as if they were distinct additional floppy drives.

Now for the unusual situation where you've intentionally booted from the CP/M Distribution Diskette #1, or other floppy that you've rendered bootable with COPYSYS:

- o Drive A: is the non-virtual floppy. Under these circumstances, if you stay logged onto A: and enter a program name without preceding it with a drive letter, CP/M will look for it on the floppy instead of the hard disk.
- o Drive B:, as you might have guessed, is now the hard disk.
- o Drives C: and D: are still the virtual floppies.

When to Boot From the Floppy?

Almost never. In general, you'd boot from the floppy only when you can't boot from the hard disk due to some malfunction. (When we say "the" floppy, we're referring to the CP/M Distribution Diskette #1 that came with the MD-11. It takes a special procedure to prepare a floppy for bootability. See "COPYSYS" in Chapter 3.)

One case when you should boot from this special diskette is if and when the hard disk fails its VERIFILE test. VERIFILE is run automatically when you first set up the computer. When you boot from the floppy, it makes the reasonable assumption that you want to reload your programs like Personal Pearl and NewWord from diskettes. If this is in fact the case, you'll be led through the procedure by instructions on the screen.

Another case where you'd boot from the CP/M diskette is if you start your day in the normal way, only to find that you get persistent hard disk errors that prevent you from going any further. This could mean that the system tracks of your hard disk have somehow been damaged. The repair procedure involves, among other things, booting from the CP/M Distribution Diskette #1.

Finally, if you boot from this diskette just for the heck of it, some things will work fine, but certain programs (like Personal Pearl) have built-in assumptions about where to look for things. Since the A: and B: drive letters are switched when you boot from the floppy, such programs become hopelessly confused and simply quit.

-- (*) --

How can I disable the Co-Pilot Menus so my MD-11 goes right to the A> prompt when I boot?

This involves changing a special file named PROFILE.SUB in user number 0 of your hard disk. This file consists of nothing but CP/M commands that are executed when the system wakes up. See PROFILE.SUB in Chapter 3, "About the Files in User 0."

Here's the easy way:

1. Start NewWord either through the menus or straight from CP/M.
2. At the Opening Menu, select L to change the logged drive. Change the drive to 0A (that's zero-A).
3. Type N to open a non-document file. Give PROFILE.SUB as the file name to edit.

4. In the file, which is very short, put your cursor on the line that reads "pilot go". Erase that line with CTRL-Y.
5. Save PROFILE.SUB with CTRL-K-X.
6. Press the RESET button. This time the menus will not appear.

You can start the menus under these circumstances any time by typing pilot go at the A> prompt. To restore them permanently, edit PROFILE.SUB again, and add the pilot go line back into it.

-- (*) --

What exactly is meant by "booting"?

Everyone's heard the expression "He pulled himself up by his own bootstraps." Of course, this is as logically troublesome as trying to propel a sailboat by putting a fan inside it. But that's beside the point.

When you turn the power switch of the MD-11 on (or press the RESET button), the MD-11 finds itself in a state of total amnesia. "Where am I? Who am I?" It fumbles for a sense of purpose and identity.

The MD-11's ROM chip contains a glimmer of recollection for the poor lost soul. "You say I should read track 0 of the disk? Yes! Yes! That rings a bell!"

If there's a floppy in the drive at this point, the MD-11 asks whether it should "boot from the floppy." It is asking whether it should read track 0 of the floppy, or track 0 of the hard disk. If you tell it to boot from the floppy, it has to find a special program in its reserved place of track 0, or nothing will happen. See "COPYSYS" in Chapter 3 for more on this program.

Normally the MD-11 goes straight to track 0 of the hard disk. "Can you help me, kind sir? I seem to have awakened in a strange and foreign land." There it finds its special program, SYSLDR.COM, that enables the computer to read CP/M from disk into memory, whereupon enlightenment prevails: the fog clears, the muscles flex, and "A>" (or the menu) is shot to your screen.

What we have described, ever so verbosely, is known as a "cold boot." There is also a warm boot, which occurs whenever you press CTRL-C at the A> prompt. This gives CP/M a fresh start, wiping clean the tables of details it's built up through hours or seconds of use.

-- (*) --

How do I change NewWord's help level once and for all?

After you've gotten used to NewWord, all those menus at the top of its screen tend to get in the way. You can change the level while NewWord is running with CTRL-J-H (also depicted as ^jh). But you have to do this every time you run NewWord.

Similarly, you might prefer "insert mode" to be off all the time, or a different set of margins. All of these details have default values that you can change with the procedure that follows. Note that we'll just cover the help level; it's up to you and the "Nuts and Bolts" section of the NewWord User's Guide to determine the specifics for other changes.

1. Escape to CP/M from the Co-Pilot Main Menu (type the ESC key).
2. At the A> prompt, type these commands carefully. Check your typing before hitting RETURN at the end of the line. Backspace and retype to correct mistakes.

```
set nw.com [rw]
nwinstal nw
```

3. Look at page 3-3 in NewWord Nuts & Bolts. Your screen should display the same "Main Menu" as is shown on that page. Select D NewWord Related Items.
4. Now you see the screen from page 4-2. This is one of the lists of things you can change by re-installing NewWord. In our example, pick B Help Level.

5. NewWord reports that the default level is now 3 (the highest) and asks if you'd like to change it. Type Y.
6. Then tell NewWord you'd like the new value to be whatever you've habitually been changing it to, probably 1.
7. NewWord confirms your selection and again asks if you want to change it. Type N.
8. Type X to return to the first menu, and X again to exit. Your last response is N, for no, you don't want to change anything.
9. When the A> returns, type:

```
set nw.com [ro]
```

and press RETURN.
10. Press the RESET button on the MD-11. Run NewWord and check it out.

As you may have gathered, there are many many details of NewWord's operation that you can tinker with, generally at no risk. All the steps are the same as above except the menu selections you make while `nwinstal` is running. Read "Nuts & Bolts" for more information.

-- (*) --

Is there a way for me to type on my keyboard and have my printer print what I'm typing at the same time?

Yes, there are a couple of ways, and one or both should work for you. But you can't be running any program like NewWord, so you're really in the same position as using a typewriter: if you make a typo, it's too late to fix it.

Whichever method you try, you should first verify that your printer is working by printing a file with NewWord.

METHOD 1: CONTROL-P

1. Escape from the menus by typing the ESC key at the Co-Pilot Main Menu.
2. When you see "A>", hold down the CTRL key and then tap the P key. Nothing obvious will happen, but your terminal may beep.
3. Now start typing. Your printer may print right along, or it may wait until you press RETURN. Those that wait allow you to correct a line for typos, in a crude way.

Unfortunately this technique isn't very useful for correspondence, since every time you type a line, CP/M repeats it and so does the printer. It is useful though for getting rough printouts of files: type CTRL-P before entering a TYPE command.

4. You can disable the printing by typing CTRL-P again or resetting the computer.

METHOD 2: PIP

This method is preferable for typing useful text, but there may be some things for you to get used to while typing.

1. Escape from the Co-Pilot Main Menu by pressing the ESC key.
2. When you see "A>", type this line and press RETURN:

`pip lst:=con:`

3. Type a few lines. See whether your printer is advancing the paper after printing a line. If it keeps over-printing on the same line, try this:
4. Instead of hitting RETURN at the end of a line, hold down the CTRL and tap both the J and M keys in either order. The meaning of this is: When NewWord (or other program) sends a RETURN to your printer, it's actually sending two separate commands. One moves the print head back to the left side of the paper (the "carriage return"). The command for this is CTRL-M. The other advances the paper one line (a "line feed"). This command is CTRL-J.

5. With many printers, you can make the paper advance to the top of the next page with CTRL-L. Check your printer manual for the other codes that will make it behave in interesting ways. For example, with dot matrix printers you can change the width of the characters.
6. To return to the menus, press the RESET button on the MD-11. (You may find that CTRL-C will get you out of the typing mode without having to reset. If so, you can then type pilot go and RETURN to get back into Co-Pilot.)

-- (*) --

How do I add other software to my hard disk?

The software you want has to be CP/M 3.0 compatible. Then, it must be available on 5 1/4 inch diskettes in any of these formats:

Morrow Micro Decision
KayPro
Osborne
Televideo
Hewlett Packard

You'll need to know whether the diskette is single or double-sided. This should be clearly stated on its label.

If it's in Micro Decision format, skip steps 2 through 4 below.

1. Escape from the menus by pressing the ESC key at the Co-Pilot Main Menu.
2. When you see "A>", type foreign and press RETURN.
3. In response to "Disk drive to be used?", type B.
4. Then select the format of the diskette that holds the new software.

5. Insert the diskette in the drive and type `dir B:` and `RETURN` to verify you've selected the right format. If you can read the diskette's directory, proceed. If you get a "media failure" error message, you've selected the wrong format in step 4 (or it's possible, though unlikely, that the diskette is defective). In that case, return to step 2 and try again.

6. At `A>`, type:

```
pip A:=B:*.*
```

and press `RETURN`. Everything on the diskette should be copied onto the hard disk.

7. When "pip" is finished, remove the diskette and press the `RESET` button.

8. Check the manual that came with your software. It may require that you run an "installation program" before you can use it. If so, escape from the menus (see step 1) and type the name of the installation program. Press `RETURN`.

9. You're on your own now. But if the installation program gives you a list of terminals, remember what the screen said way back when you first used the MD-11. It's not likely that you should actually pick your own terminal from the list, but one of these three instead:

```
Lear Siegler ADM-31 (Level III) - true for all
Morrow terminals
SOROC IQ-120 (Level II)
Lear Siegler ADM-3A (Level I)
```

If you don't remember what level your terminal is, try installing your software for the ADM-31. Then run it. If the screen looks screwy, run the installation program again, this time choosing the SOROC. If that fails, try it once more with the ADM-3A.

Be aware that you can't run added programs from the menus without extensive editing of the Co-Pilot program `MICRO.PIL`. So you'll either disable the menus or escape from them whenever you want to use the new program.

Should you decide to revise the menus to include other programs, may we suggest that you make a backup copy of the unchanged MICRO.PIL first. It is on the hard disk in user number 0. Use NewWord's N option (non-document) for working on the file.

-- (*) --

How can I create a Micro Decision diskette that is a duplicate of a diskette from a different system?

Or, How can I create a foreign diskette with files on it from my Micro Decision?

These questions are very related to the one above about loading other software onto the hard disk. They both involve using the foreign program.

Copying a foreign diskette onto a Micro Decision diskette

To copy another computer's diskette onto a Micro Decision diskette, it must be a CP/M 5 1/4" diskette in one of these formats:

Osborne	IBM PC	KayPro
Hewlett Packard	Televideo	

1. Follow steps 1 through 7 (including RESET) in the previous question for copying the foreign diskette onto the hard disk. While PIP is running, write down all the names of the files that are being copied from the foreign diskette.
2. When PIP is finished, format a Micro Decision diskette by typing format B and a RETURN at the A> prompt. (Be careful not to format the foreign diskette by mistake.) If the Micro Decision diskette will be used exclusively on MD-3's and the MD-11, select double-sided format (D). If it needs to work with an MD-2, select S for single-sided. Note that a single-sided diskette may not hold everything that's on the foreign diskette.

3. After formatting, leave the diskette in the drive. Then at A>, type:

`pip` (press RETURN)

4. Next to the asterisk (*), type:

`B:=filename`

where "filename" is the name of the first file from the list you wrote in step 1 above. Press RETURN. When the asterisk returns, type the next file name. Continue until all of the files have been copied.

5. After the last file's been copied to the diskette, press RETURN at the asterisk. A> reappears.
6. You could quit now, but you may want to erase the files from your hard disk if you don't plan to use them. If so, type `era` and the name of the first file on the list. (DON'T type the "B:" this time.) Continue typing `era` commands for all the files on the list.

Copying files from your hard disk onto foreign diskettes

You might do this to share data or programs with someone who has one of the computers listed on the previous page. The diskette you're copying onto must have been formatted already on the other computer.

Read the discussion above under "How Do I Add Other Software To My Hard Disk?". This procedure is very similar.

1. Follow steps 1 through 5 of "Adding Other Software."
2. At the A> prompt, type `pip` and press RETURN.
3. Next to the asterisk (*), type:

`B:=filename` (press RETURN)

where "filename" is the name of the first hard-disk file you want to copy. Continue typing "B:=" and file names until all of the desired files have been copied. Then press RETURN at the asterisk.

4. Type `dir B:` and RETURN to check the floppy's directory for the copied files. Remove the diskette.
5. Press the RESET button on the MD-11.

One thing to keep in mind is that when you share a program with someone, aside from the question of copyrights, there will almost certainly be more than one file involved. There will be at least one file ending in `.COM`, and probably another ending in `.OVL` or `.OVR`. Then there may be associated data files. So check the program's manual for a list of necessary files.

-- (*) --

How can I translate the Co-Pilot menus into another language?

This is a fairly simple process, but be aware that you'll be editing a program, not just sentences. If you follow the directions carefully, there should be no problems. So it is possible to throw the program out of whack by changing things you're not supposed to. Just make sure you use this method, which leaves the original program intact - you'll be working on a copy.

1. Escape from the menus by pressing the ESC key at the Co-Pilot Main Menu. When you see "A>", type `nw` and press RETURN to start NewWord.
2. At the Opening Menu, type `N` to open a non-document file. Give `MIC.PIL` as its name. Verify that you want to create a new file with `Y`.
3. As the very first step after opening the new file, type `CTRL-K-R` (the same as `^kr`) and give `MICRO.PIL` as the name of the file to insert.
4. Now you have a fresh copy of the menu system that you can change as you please without damaging the original `MICRO.PIL`. The lines you are looking for begin with `T:`, `TY:`, `TN:`, and `TNR:`

NOTE: DON'T CHANGE ANY LINES EXCEPT THESE "T" LINES.

If one of these TYPE command lines contains a variable, like `#USER` or `$FILENAME`, DON'T translate the variable name. Work around it.

5. Save the file after working for a while with CTRL-K-X (^kx). Test it by typing at the A> prompt:

```
set mic.pil [sys] (press RETURN after each line)
pilot mic
```

6. If it seems to be alright, start NewWord again, and choose N to open the non-document MIC.PIL - not MICRO.PIL. Continue translating and testing. If at some point the program ceases to work right, you can try to fix it according to the PILOT manual. You may be forced to erase MIC.PIL and start over at step 1.
7. When you're satisfied that the program and translations, enter these commands at A>:

```
ren micro.old=mic.pil
ren mic.pil=mic.pil
pilot go
```

These commands make the original file inactive, replacing it with the translated version. If for some reason you want to switch back to the original, just re-enter these commands (the bottom one FIRST, this time) also reversing the names on either side of the equal signs.

These steps take care of the Main Menu and Utility menu. To translate the CP/M Tutorial, use the same procedure, but name your new non-document TUT.PIL in step 2, and insert TUTORIAL.PIL in step 3. The bold command lines will also change accordingly.

To translate the installation program, the new non-document should be named MDI.PIL in step 2. The file to insert in step 3 is MDINST.PIL.

The very first congratulatory message that appears when you set up the MD-11 is in a file called STARTUP.-PIL. Name your non-document START.PIL and insert STARTUP.PIL. Be aware that if you want this program to run on a cold start (as if this were the first time the MD-11 was used), you need to rename START.PIL to INIT.PIL.

A final note: Some of the MD-11's messages (like error messages) come from the ROM and so are not part of the menu system. You cannot translate these messages without creating a customized ROM.

-- (*) --

Sometimes you warn me NOT to press the RESET button, and other times you tell me I MUST do it. What gives?

There are times when pressing RESET (the little square button on the lower right of the MD-11's front panel) can mean disaster. But most of the time, it's perfectly harmless. It just makes the MD-11 start over. If you haven't disabled the Co-Pilot Menus, pressing RESET takes you to the Main Menu.

In general, you should avoid "resetting" whenever a file is open for writing, that is, when you're making changes to a file. When you're editing a letter with NewWord, or typing data into a spreadsheet with SuperCalc, there's a file opened for writing.

On the other hand, a file can be opened for reading only. When you're printing the letter, it's opened for reading only and resetting will do no more harm than stopping the printout.

Here are a couple of rules:

- o If you've escaped to CP/M (the A> or similar prompt is onscreen), it's OK to reset. This will clear any temporary changes you might have made with the SETUP program, and sets any foreign drives you've assigned back to Morrow format.
- o If the Co-Pilot Menus are onscreen, it's OK to reset. They'll stop whatever they were doing, however.
- o If you're printing something, it's generally alright to reset. The printing stops and must be started over again.
- o If you're entering data into a file with one of your programs, you should NOT reset until you've saved the file.

Now, why would you want to reset in the first place? There are several reasons: The system has locked up and doesn't respond to any keys; you've gotten hopelessly lost in the nether depths of a program and can't find your way out; you keep getting errors of some kind and can't figure out how to get around them; or you just wanted to start a program and abort it in its early stages, for whatever reason.

-- (*) --

What's that odd little connector labelled "RS-422" on the rear of my MD-11?

That is a high-speed synchronous port, designed for communications with a mainframe (big) computer. There is no software for it as yet.

This port shares some of the same signals and has the same address as the Auxiliary RS-232 port next to it. It also has additional signals that are used only in synchronous communication.

For more information, see Appendix D.

-- (*) --

What do I do if I buy a new printer or terminal after I've installed all of my programs?

New Printers

Let's begin by listing a few possibilities:

- o You had a serial printer, now you have a parallel
- o You had a parallel printer, now you have a serial
- o You had and still have a serial printer
- o You had and still have a parallel printer

If either of the latter two is true, your life will be easier.

In any of these cases, you should run the program `nwinstal` as described under "How do I change NewWord's help level?" Instead of changing the help level, though, you'll be changing the printer selection. Select "Printers" from `nwinstal`'s main menu instead of "NewWord related items."

If you don't see your new printer or a lookalike on `nwinstal`'s printer list, try Draft Printer.

Now then. For those of you who substituted serial for parallel or vice versa:

1. Escape from the menus by typing the ESC key at the Co-Pilot Main Menu.
2. At the A>, type `setup` and press RETURN.
3. Turn to "Setting Up Serial Printers" in chapter 1 of this manual. Read the description of setup. The B key controls whether you have a serial or parallel printer. Set it accordingly. Also note the other details about serial printers, if this is the type you're changing to.

That's it!

New Terminals

You should try the new terminal first without changing anything. It may work just fine. Be sure it's set up correctly, as described in Chapter 1 of this manual. We hope, incidentally, that you bought one of the terminals listed on the first page of Chapter 1.

If you're upgrading from a Level I or Level II terminal, or if the terminal isn't working right even though it's set up correctly, do this:

1. Escape from the menu system by pressing the ESC key at the Co-Pilot Main Menu.
2. At the A>, type `init` and press RETURN. Select your new terminal, or one that acts just like it, from the list that appears. If your terminal or one it emulates isn't there, select "None of the above" and read what the screen says in response carefully.

3. When A> reappears, press the RESET button. See how your terminal performs. If you're still having problems, ask your dealer for help.
4. Get back out of the menus as in step 1. At A>, type `pilot mdinst` and press RETURN. This is the same installation program that you used when you first set up the MD-11. Some parts of it won't work right, but it will keep going. The part that's of interest is NewWord installation; NewWord will automatically be reinstalled for your new terminal.

-- (*) --

What's the best way to learn about CP/M?

Obviously, the thing to do is break out of the menus with the ESC key and try a few things.

But first you should go through the "Basic Training in CP/M" option on the Co-Pilot Utility Menu. This teaches you the most basic things you should know.

Then you might try the exercises in Chapter 2 in the section on the Utility Menu. These will give you a taste for entering commands without having to make them up yourself.

Finally, dig into the CP/M Plus User's Guide. This is one of the five-volume set that came with the MD-11. There's no substitute for experimenting. There are a number of other books about CP/M in bookstores, with varying degrees of quality. We suggest browsing through them to find the one that's on your present level. Be sure it discusses CP/M 3.0, not just version 2.2.

-- (*) --

How can I run my application programs directly from CP/M?

The first thing to do is either escape from the menus by pressing the ESC key at the Co-Pilot Main Menu, or disable the menus altogether as described earlier in this chapter.

When you see "A>", you're ready for the next steps.

You must log into a certain user number with the user command. Then start the program. The user numbers dedicated to the particular programs at the factory are shown below. There's nothing to stop you from staying in user 0, or trying to run the program from user numbers other than those shown. But for the sake of keeping your data organized, you should stick the numbers below.

<u>Program</u>	<u>User Numbers</u>	<u>Typical command</u>
NewWord	1, 2, 3	user 2
Correct-It	1, 2, 3	user 1
SuperCalc	4, 5, 6	user 4
Personal Pearl	7, 8, 9	user 9
Quest	10, 11, 12	user 10
BASIC	13	user 13
BAZIC	14	user 14

When you run these programs (except BASIC and BAZIC) through the menus and pick a file drawer, you are doing the same thing as entering the user command. Notice the message next to the file drawers. It tells you the correlation between a certain drawer and a certain user number. Drawer 1 is the first of the three available, and so on. We mention this because you may have a file you want to work with that's present in only one of the three possible user numbers. So you have to be sure to enter the right user command before going on to the next one.

The commands for running the programs are listed below. Enter the user command (and RETURN) before typing the program command.

<u>Program</u>	<u>Command</u>	<u>Program</u>	<u>Command</u>
NewWord	nw	Personal Pearl	
SuperCalc	sc	Welcome	welcome
Quest	kp	Design forms	pearldf
MBASIC-80	mbasic	Design reports	pearldr
BAZIC	bazicl0	Enter data	pearled
Correct-It	correct	Print reports	pearlpr
		File maint.	pearlfm

To run the program, simply type the command and press RETURN. For example, to run Correct-It on a file in user number 2, type:

```
user 2 [RETURN]
correct [RETURN]
```

After the first command, the A> prompt changes to 2A> to let you know you've logged into user 2.

If you want to get back into the menus after running the program, type user 0 and press RETURN, then type pilot go and RETURN.

-- (*) --

CHAPTER 5

----- ERRORS AND OTHER NUISANCES

Computers rarely break down, but moving parts can wear out, and electronic parts on rare occasions fail to perform. And, although there is a great deal of excellent commercially available software, most users eventually happen upon a program with "bugs." There is also the occasional, perfectly understandable, human error.

There are two general classes of error messages: operator and disk. Operator error messages occur when you try to do something illegal (like erasing a read-only file) or dumb (like trying to copy a file that isn't there). These messages are fairly self-explanatory so we won't worry about them.

The disk error messages are another matter. CP/M sends these out with apparent glee over their incomprehensibility. Lucky for you, Morrow's customized version of CP/M traps these messages and translates them into English. Beyond this, Morrow's CP/M gives you some very explicit options as to how to respond.

This may become a familiar sight (we hope not):

```
=====  
Disk error on drive x: (...error message...)  
Type R to try again, A to abort, or I to ignore:  
=====
```

The "x" represents the drive letter for the disk that's having a problem. The possible error messages are covered next; then we'll see what the R, A, and I options are about.

Drive Not Ready

The disk drive is not ready. If it refers to the hard disk, it usually means that the disk isn't rotating at the right speed. With floppies, a number of things may be happening, including no diskette in the drive, drive door open, or a problem with the drive, cable or disk controller. In some cases, the problem can be solved by simply opening and closing the drive door. If you cannot get the system to work, consult your dealer.

Write Protected

You have attempted to write to a diskette that is write protected. That means that the write protect notch is covered. If you want to write to that disk, you must remove the write protect tab and try again.

Some diskettes do not have a notch and are therefore permanently write protected. These are generally software distribution diskettes that were protected by the manufacturer to avoid accidental erasure or damage. In most situations, the files on these diskettes can, and should, be copied to the hard disk or a backup floppy.

Not Found

The disk controller is unable to locate information on the disk. With the hard disk, this means trouble. Type R for retry several times. If this message appears when trying to work with several different files, it's time to restore them from your backups.

With diskettes, This can be caused by trying to access a disk that is either damaged, unformatted, or formatted for a computer other than the Micro Decision. If you are sure that your diskette is properly formatted, it may have been damaged. If you suspect that this is the problem, use the "Copy a file" option on the Utility Menu to copy as much of the information as possible to a freshly formatted diskette.

Data Address CRC Error
ID Address CRC Error
Data Error

Whenever information is written on a diskette, additional error control codes are also written. When the information is read back, these codes allow the disk controller to determine if the information has been read correctly. This error is usually caused by a damaged or incorrectly formatted disk, or by a hardware failure in the drive or controller. Whether or not you recover from the error, try copying the contents of this file into a new file with the "Copy a file or files" option from the Utility Menu.

Equipment Failure

Is that "Taps" playing in the background? Try resetting the computer; then try turning it off and back on. If you can operate the machine at all, be sure you've backed up whatever files you can. Then boot from your Backfield Working Diskette and follow through the steps for restoring the hard disk.

It's possible that even this won't work. In that case, you'll need to take the MD-11 to your dealer for service.

Media Failure

This message is usually associated with floppies whose format isn't right for the MD-11. You may run into it when running the foreign program. Be sure the diskette you're trying to use is one of those allowed with foreign, and that you've selected the right option.

Seek Error

The disk drive was not able to find the correct track on the disk. This can be caused by a diskette which is improperly inserted in the drive, or incorrectly formatted. This can also be caused by a hardware failure in the disk drive.

Unable to Remap

Your hard disk does its best to locate the marginal parts of its surface and keep information from going there. This is called "bad mapping." This error message indicates a failure in this process, and is not good news by any means. If it repeats consistently after rebooting and turning the power off and back on, boot from the Backfield diskette and restore your system from your Backfield backup diskettes.

Unknown Error Code

None of the above. Something strange has happened; retry a few times before aborting.

Error Message Responses

After displaying the error message, your Micro Decision waits for a response from you. Only an R, A, or I will be accepted. The results of using these keys are described below.

R - to Try Again

This is always the first thing to try. Enter an R to try the disk operation again. This is obviously helpful if the error was due to an open drive door, a write protected diskette, or something else that you can easily correct. Sometimes, too, other errors can be cleared by trying again.

A - to Abort

This is nearly always the thing to do after pressing R several times with no success. Enter an A to abort (terminate) the disk operation. This causes a system "warm boot", re-loading CP/M. Any information which was in memory is lost.

However, when you press A, CP/M gives you the name of the file that caused the problem. This can be extremely helpful when trying to figure out what to do next. If it's one of the program or overlay files that has a copy on one of your Distribution Diskettes, you can restore it with the "Copy a File or Files" option from the Utility Menu.

When you restore such files, you may need to set the damaged hard disk file to read/write status with the CP/M command `set filename [rw]`. After copying in the new floppy file, set it to system status with `set filename [sys]`.

But suppose the problem is in one of your data files, such as a NewWord document. The obvious thing to do is try working with the .BAK file created by NewWord, or copy back a diskette backup version. Alternatively, try copying the offending file into a new file with a different name. Try R several times at the failure point, and then I for ignore. (This is recommended for Data or CRC errors.) The copy will have some amount of "garbage" in it at the failure point, but this may be limited to a few easily-repaired lines. At least the error won't occur with the copy as it did with the original.

I - to Ignore

Enter an I to ignore the error and continue as if nothing had happened. This should be used with extreme caution, especially when writing data to a disk. Using this response can lull you into a false sense of security, since disk operations appear to proceed normally, despite the possibility of a faulty disk or other problem.

The only safe way to use I is this: You have already tried R several times and it didn't help. Then you used A to abort and made a note of which file had the problem. If you had no backup for it, you tried copying the faulty file into a new file, retried at the point of failure, and finally resorted to I. Now you can look at the file (assuming it's a data file - you should certainly have backups of all program files) and locate the garbage. Take out the trash, son.

Nonrecoverable Errors

Some error messages do not give you the option of A, R, and I. These errors occur before the disk operation actually begins. They cause a "warm boot", which reloads CP/M and erases any information that was in memory. If you encounter one of these errors, an error message will be displayed in the form:

CP/M error on drive x: (...error message...)

where x is the drive where the error occurred.

Possible errors are:

Select Error

An invalid drive name was entered. Valid names are drives A: through D:.

Disk Read Only

An attempt was made to write to a drive which CP/M has set to "read only". CP/M automatically does this whenever a diskette is changed in a drive without a "warm boot". This is done to prevent CP/M from inadvertently writing to the wrong disk. Programs can also explicitly set a drive to "read only", but this is rarely used.

File Read Only

An attempt was made to write to a file which has been set to "read only". The SET command can be used to set a file to "read only". This is one way to protect your files from accidental erasure or modifications. Refer to the CP/M User's Guide for more information on the SET command.

Summary

There are several levels at which you can approach disk errors. If you're given the A, R, & I options, try R at least three times, then A. Use I only as described above.

If you get frequent errors of this type, it's probably time to reformat your hard disk and reload all the programs and data. You can do so only if you've made regular backups.

When the machine is brand new and you have problems before you've ever used it, you should boot from the CP/M Distribution Diskette #1 by putting it in the floppy drive, closing the latch, and pressing RESET. Follow the directions onscreen for reloading the software from the rest of the distribution diskettes.

However, in the more likely case that you've added a significant amount of data to the hard disk, you should boot from the Backfield Working Diskette instead. It leads you through the procedure for restoring your hard disk from the diskettes you made yourself while running the Backfield programs.

APPENDIX A

----- ABOUT YOUR SYSTEM

We've buried this highly descriptive section back here since it gets in the way up front, when you're anxious to get things hooked up and running.

The Morrow Micro Decision MD-11 is a sophisticated and economical hard-disk computer system. With an optional Morrow terminal and a printer, you have all the hardware and software you need for word processing, proofreading, accounting, data base management, financial modeling and programming.

The Operating System

Because your system comes with the CP/M operating system, you are able to choose from the world's largest library of professionally written business application programs (although you may find that more than you'll ever need has been included with the system!). Your Micro Decision comes with BASIC and Morrow's PILOT programming language, Morrow's exclusive Co-Pilot Menus and many specialized programs for such tasks as backing up the hard disk, program editing, and other "utility functions."

The Hard Disk Itself

The hard disk gets its name because it is not flexible like a floppy diskette. You don't remove it like a diskette. The hard disk stays put. There are other significant differences between a hard disk and a diskette.

Unlike a floppy, the read-write "heads" inside the drive do not physically rest on the actual disk. The heads and the disk are separated by a cushion of air. Once you turn on your system, you cause the hard disk to spin at a tremendously high speed - 3600 revolutions per minute - 12 times faster than a diskette.

A hard disk outperforms a diskette for several reasons:

More information more quickly. Since the disk is spinning so fast, the head can read and write information more quickly.

More storage. You just have more sheer storage space. A double density double-sided diskette can store up to 384K or roughly 400,000 characters. Your 11 megabyte hard disk system is equivalent to more than two dozen diskettes housed under one roof.

Less wear and tear. Since the hard disk is sealed in an airtight enclosure, it's protected from the many mishaps that befall floppies. This includes coffee and soda spills, dust and smoke, fingerprints, ball point pen impressions, - all the "no-nos" that every technical manual warns you against. The hard disk also has a longer life span than a diskette - 8000 to 10,000 hours as compared to a floppy's 1600 hours.

How Floppies Fit Into the Picture

You also have a floppy disk drive. You ask, "What's it for?" Good question. You will be using floppies to load new programs onto the hard disk, or to store backup copies of your hard disk files.

"Virtual" Drives

The MD-11 can pretend that it has two more floppy drives than it actually has. You will use this feature to copy files directly from one floppy to another, or perhaps when reading and writing in foreign disk formats.

Virtual drives are extremely useful in floppy-only systems, where you may be dealing with three diskettes at a time. With a hard disk, however, there is less need for this feature. Nonetheless, here's an example of copying a file from one floppy to another without getting the hard disk involved:

- o Suppose you want to copy a program onto a Micro Decision diskette from an Osborne diskette. First, you'd escape to CP/M from the menus. Then you'd run FOREIGN and assign drive C to be Osborne format. Then you would enter a copy command like:

pip B:=C:osbprog.com

("osbprog.com" is used here as just an example.) Your screen responds:

Your floppy drive is being reassigned as drive C. Exchange diskettes and press RETURN.

So you'd put in the Osborne diskette and the MD-11 would read osbprog.com into memory. Then the drive is reassigned back to B, or regular Micro Decision flavor. Switch diskettes again, and osbprog.com is written from memory to the Micro Decision diskette. If osbprog.com can't fit into memory all at once, you'll switch disks at least twice.

Thus you have performed an operation that normally requires two disk drives with only one. This is what virtual drives are all about.

SYSTEM HARDWARE

Here's a breakdown of your system hardware: the nuts, bolts and gizmos that make your system run.

- o 280A (8-bit) Central Processing Unit (CPU)
- o 128K bytes of internal Random Access Memory (RAM)
- o 3 RS-232C serial ports
- o 1 Centronics-type parallel printer port
- o 1 RS-422 high speed synchronous communication port
- o Disk drive controller for one or two 12 megabyte (unformatted) hard disks and one or two 5 1/4 inch floppy drives - NOT 8 inch, by the way
- o 1 hard disk with 11 megabytes of formatted storage
- o 1 double sided floppy drive, 384 kilobytes formatted

SYSTEM SOFTWARE

And now for the actual programs which let you go about your business. These programs have been pre-recorded on your hard disk. You have also either received individual distribution copies of each program, or will soon create backup copies yourself. (Save these! Put them away in a safe place. If you ever have your disk serviced, you may need to copy them back onto the hard disk.) Here's what you have:

- o CP/M version 3.0 Operating System
- o NewWord Word processing program
- o Correct-It Checks and corrects spelling
- o SuperCalc Financial modeling
 ("electronic spreadsheet")
- o Personal
 Pearl A versatile data base
 management package that
 allows design and produc-
 tion of forms and reports
- o Quest A powerful accounting and
 bookkeeping package
- o MBASIC-80 Microsoft BASIC programming
 language
- o BAZIC NorthStar compatible BASIC
- o PILOT Morrow's version of this
 popular programming
 language
- o BACKFIELD Backup program for the
 hard disk
- o Co-Pilot Menus Your road map through CP/M

SYSTEM REQUIREMENTS

Your MD-11 comes with all the basics (computer hardware and software) needed to get started, but to complete your system, you will need the following:

Terminal

A computer terminal is required for communicating with your computer. Although the Micro Decision works with most computer terminals, the Morrow MDT-60 and MT-70 are recommended for those wishing to take full advantage of the software included with the MD-11.

Diskettes

The floppy drive in the MD-11 use 5.25 inch soft-sectored double-sided floppy diskettes. For best results, use only premium quality diskettes that are certified for use as double-sided and double-density. These diskettes are available from most computer and office supply dealers. You need at least seven diskettes for your first full backup of the hard disk. We recommend that you have a box of ten diskettes on hand.

CAUTION: Diskettes are vulnerable to accidental erasure or damage. Before you begin using them, please read Appendix B for important information on their care and handling.

OPTIONAL HARDWARE

There are three RS-232 serial port connectors on the back panel of the Micro Decision. One is marked TERMINAL, another PRINTER/MODEM, and the other AUX. One RS-232 port must be used for your terminal. The others can be used for a printer, a MODEM, or any other serial device that is compatible with your system. See Appendix D for information on how to set up these ports.

Printers

The Micro Decision works with most letter quality and dot matrix printers. Serial printers plug into the back panel RS-232 port labeled PRINTER/MODEM. Parallel printers connect to the flat edge connector on the back panel labeled CENTRONICS PARALLEL. In some cases, the set up of the printer serial port may need to be changed (for a different baud rate, for example). This procedure is described in Chapter 1.

Modems

A modem (short for MODulator-DEModulator) connects your Micro Decision to a telephone line and allows you to exchange programs and data with other microcomputers, or with larger computers. You can also access computerized information services such as The Source and CompuServe with a modem.

The modem connects to the RS-232 interface on the back of the system unit labeled PRINTER/MODEM, or if you're using a printer on that port, you can connect the modem to the AUX port.

Morrow has made available its own intelligent modem (Model MM300) that comes with complete controlling software. Your dealer can provide you with information about other modems that can be used with your Micro Decision. Again, see Appendix D for information on connecting these devices. (Note: Connecting your Micro Decision to a modem requires special communications software that is usually supplied with the modem itself.)

ADDITIONAL SOFTWARE

The Micro Decision was shipped with several useful and popular application programs. In addition, your Micro Decision is capable of using most of the many programs that run using CP/M. This opens the door for communications programs, games and much more. Some of the CP/M users groups distribute free software. See your dealer for information on available software.

You also need to know that there are several CP/M diskette formats. By format, we mean the pattern on a diskette that the operating system expects before it can read or write information on it. The Micro Decision uses standard 5 1/4" soft sector diskettes, but in order for it to read a program or data diskette, the diskette must use a format that the Micro Decision knows about. A format program is included on your system diskette to prepare diskettes for use with your system.

In addition to diskettes specially formatted for the Micro Decision, your system can run program diskettes, and read and write data diskettes that have been formatted for the Osborne, Televideo, Hewlett Packard, and Xerox computers. Additionally, it can read and write to CP/M-86 data diskettes formatted by an IBM Personal Computer.

Software publishers and distributors are generally able to provide CP/M programs in one of the formats available on the Micro Decision.

THE CO-PILOT MENUS

The CP/M operating system has many powerful commands. Although they can be learned with a little practice, they tend to be somewhat intimidating for the novice user. To make your Micro Decision easier to use, we have implemented the Co-Pilot Menus - a series of screens which allow you to enter commands with no knowledge of CP/M. Using the menus reduces many complex commands to a single keystroke - a feature that even experienced computer users will appreciate.

All of the commands executed through your Co-Pilot Menus can also be executed directly from CP/M. If you study the screen as you use the menus, you will see what the operating system is actually doing. It's as if you have a CP/M expert sitting next to you, pressing the keys as you watch.

-- (*) --

APPENDIX B

----- THE ABSOLUTE ESSENTIALS

This section will be too elementary for most users, even if you've never had a computer before. You probably learned this material as part of your computer-shopping research. But just in case, here it is.

If you've never handled diskettes before, you should read "Floppies: Why Are They so Sensitive, Anyway?"

Hardware, Software, Wash-n-ware: Ware Does It All Lead?

There are two essential elements to any computer system - hardware and software. If you think of your computer as a stereo system, your hardware is like the turntable, amplifier, tuner and tape deck. The software is like your music collection, whether it is on records, tapes, or even FM radio signals. Music brings out the value and power of a fine stereo system. Software brings out the value and power of your Micro Decision.

Or, for a different image that might appeal more to the computer-haters among you: Hardware is the Frankenstein monster, an assembly of pieces from various vendors, dormant on a slab. Software is the lightning-bolt that jolts the monster to life, enabling it to run rampant over the innocent villagers of planet Earth.

Types of Software

There are several types of software, including operating systems, languages, programs, and data.

The operating system is the interpreter which allows the hardware to "talk to" and "listen to" the software. It is an essential element to any system. Your MD-11 comes with the CP/M operating system, version 3.0 (also known as "CP/M Plus"). It was selected not only because it is a high-quality product, but because it supports a large number of business and personal software packages.

You need an operating system because people who write software don't want to write it specifically for one computer. That limits the market too much. But if they can write it for one operating system that's used on lots of different computers, well now, that's a different story. So CP/M acts as the interpreter between the very unique hardware of the MD-11 and the very general nature of software like NewWord and Personal Pearl.

A language is the set of rules and terms that a programmer uses to write programs. The language, working through the operating system, tells the machine what the programmer wants it to do. There are many languages compatible with the MD-11, ranging from the highly complex, like Z-80 assembly language, to the simple, like PILOT or BASIC.

A program is a set of instructions written in a particular language, that makes your system do what you want it to do. If you want to use your Micro Decision as a word processor, you must use a word processing program, such as NewWord. Additional programs may be purchased, and you can write some yourself using one of the languages provided with your Micro Decision.

Data is the information being processed. If you use NewWord to type chain letters, the actual words of the chain letter are your data, worthless though they be.

As an illustration, let's trace a letter created with NewWord. The letter is data created by the NewWord program. NewWord is written in assembly language and runs under the CP/M operating system.

Files: Your data is stored on the hard disk in files. Think, for a moment, of your hard disk as a filing cabinet. It has 16 "drawers," or user numbers. Each user number can contain lots of different files.

A file is the unit of data you work with. It can be completely empty, or it can contain the unabridged "War and Peace." There are several types of files; NewWord actually consists of three program files, two "overlay" files, and three sample text files. Personal Pearl uses over 60 different files!

You too will create files. Every time you type a document with NewWord you create a new file. When you generate a new spreadsheet with LogiCalc that's a new file too. The MD-11's menus and CP/M let you name files, copy them, and erase them.

Computer Hardware

The hardware on your Micro Decision consists of a cabinet, a power supply, a central processing unit, memory chips, a disk drive controller, a hard disk, a floppy disk drive, and an assortment of chips, resistors, plugs, and wires.

The "brains" behind the system is the Z80A central processing unit (CPU). That sounds (and is) impressive, but it's actually only one chip, about 3/8 inches square.

Another essential element is the Random Access Memory (RAM). Your system is equipped with 128k of memory. Each "k" (short for kilobyte) consists of 1024 bytes or characters. This translates to 131,072 bytes - each byte being the equivalent of one single number or letter.

The Random Access Memory determines how much information your computer can manipulate at any one time. Information stored in RAM can be instantaneously accessed by the computer. RAM acts as a temporary storage area. Any information in RAM disappears when a new program is run, when the computer is turned off, or when the electric company decides to interrupt your power. Fortunately, you have a more permanent means to store information - the hard disk. And as a double safety measure, you will routinely copy what's on the hard disk onto backup diskettes.

Disks and Disk Drives

Information (data and programs) is transferred between the hard disk and RAM via the disk controller and disk drives. Disk drives are a little like tape recorders. They read and write magnetically encoded information on the disk. Disks are similar in substance and function to magnetic tape. The disk drive can add information to a disk (as long as there is room) or it can record new information over old, erasing the information that was there before.

Disk Drive Letters

An incidental bit of info: Disk drives have certain letters associated with them. Nearly always, the hard disk is your "A" drive and the floppy is "B". Then you have two "virtual" drives C and D, which are used when you need to pretend that you have more floppies than you actually have. Virtual drives are a carry-over from all-floppy computers. They are much less needed with a hard disk system.

The only thing that would change the A and B letters is if you should need to "boot from the floppy". This is a rare occurrence that usually means your hard disk is having problems. When you boot from the floppy, the floppy becomes drive A and the hard disk B. C and D are still virtual floppy drives.

The Hard Disk

Your hard disk is probably the reason why you bought the MD-11. If you've had extensive experience with a floppy-only computer (or, heaven forbid, one that uses cassette tapes), you'll be pleasantly amazed at how convenient a hard disk system is to use. Not only is it strikingly fast, but there's no swapping floppies around, logging onto this drive and that, forgetting which diskette is which. . .

No, it's all there in one place. Eleven million letters, numbers, and other characters. This is about 5,000 standard pages worth.

But - all this information crammed onto one mechanical device is a frightening prospect to people who've lost data to malfunctioning hardware. Therefore it is essential that you develop good backup habits, and take good care of the hard disk. The rules of the road are:

1. Make a full backup of the hard disk as soon as you can, as described in Chapter 2 under "Backfield."
2. At the end of each day, make an "incremental" backup with Backfield. This backs up only the files that have changed since the previous backup. Now the absolute worst that can happen is the loss of one day's work.

3. Always PARK your disk heads before turning the MD-11 off. This selection is also covered in Chapter 2.
4. Avoid jolting the MD-11. Move it smoothly and carefully. When transporting it over long distances, pack it in its original packing materials.

We don't mean to scare anyone into thinking that the MD-11 is sitting there waiting for a chance to gobble up your data. It's doubtful you'll ever run into any serious problems. But we don't want to lull you into thinking you can just let the thing accumulate data month after month with nary a backup. That's downright foolhardy. So follow the rules above, and all will be well, because (if we may quote every technical manual ever written) "this quality machine was designed to give you years of trouble-free service."

Floppies: Why Are They So Sensitive, Anyway?

The figure below shows the external details of a floppy diskette. Unlike the hard disk, the recording surface of a floppy is exposed to the elements, i.e. your fingers, magnetized paper clips, dog teeth. . .

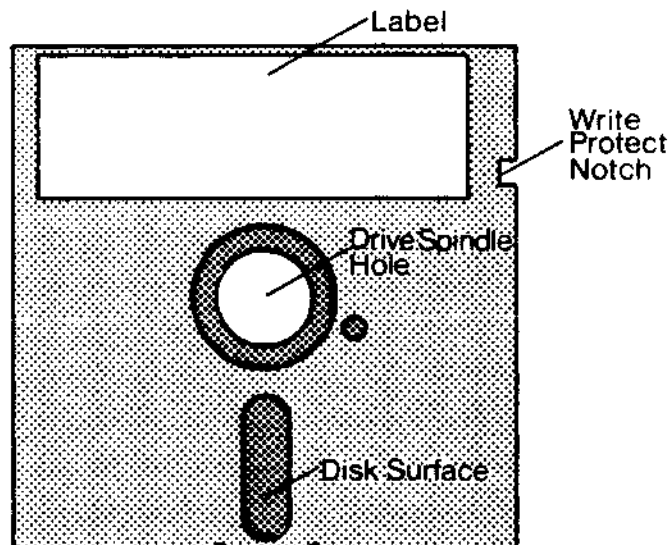

Figure B-1. Floppy Diskette Features

Here are some basic do's and dont's for diskettes:

1. Always hold them by the label end. DON'T touch the exposed surface.
2. Don't try to remove them from the black sleeve that surrounds them. (Don't laugh - people have been known to do this.)
3. Don't try to force a drive door shut on a diskette. If you're meeting resistance, the diskette is probably inserted wrong.
4. Write information on a label before you stick it on the diskette. If you must write on an already-stuck label, do so with a felt tip pen, NOT a pencil or ball point.
5. Remove diskettes from the drive before turning off the MD-11. Store them in a clean dry place, inside their paper sleeves.

Formatting Diskettes

We just want you to be aware at this point that you always have to format brand new diskettes before you can use them with the MD-11 (or any computer). Each computer has its own special way of formatting, so unless your friend has a Micro Decision, you won't be able to format diskettes for each other.

Formatting a diskette takes about two minutes. It is a fully automatic operation that you execute from the Co-Pilot Utility Menu.

A final word: Although you can format diskettes only in Micro Decision format, your MD-11 can read and write on diskettes formatted on several other computers. See "FOREIGN.COM" in Chapter 3.

Write Protection

Notice the "write protect notch" in Figure B-1. This notch should be uncovered when you buy brand new diskettes. An uncovered notch means that you can format the diskette, copy files onto it, and rename or erase them as you wish.

Diskettes usually come with a little sheet of stickers designed specifically for covering this notch. When it's covered, you can do nothing with the diskette but read information off of it. This is write protection. You would normally write-protect very valuable backup disks to keep them from being changed or erased.

Apply a write-protect sticker by wrapping it around the notch, neatly covering it on both sides.

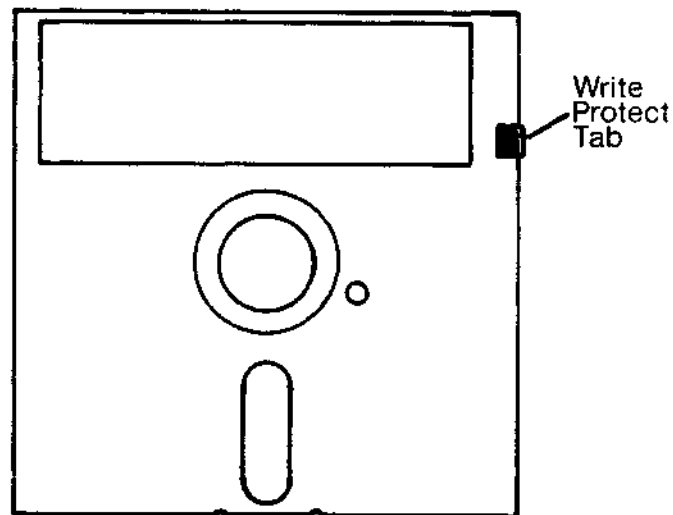

Figure B-2. A Write-Protected Diskette

Procedure for Inserting Diskettes

1. Open the door of the disk drive. There are several types of latches, but virtually all of them have a handle that covers the slot for the diskette. You open the latch by flipping it up or to the side so that the slot is now uncovered.
2. Touching only the plastic shield and label, insert the diskette all the way into the drive with the label facing up and the notch (if any) to the left. The exposed oblong shaped area is inserted first. Think of that oblong as an arrow, pointing the direction in which the diskette is inserted.

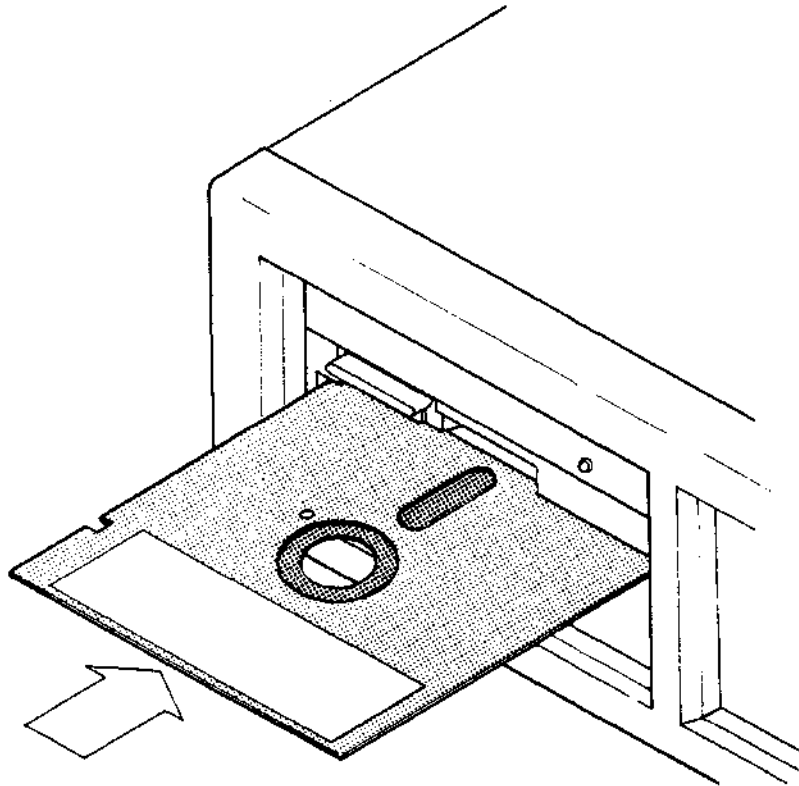

Figure B-3. Inserting the Diskette

3. Close the disk drive door by flipping the latch down again. Don't force it - if it seems stuck, open it, remove the diskette, and start over.

About Your Keyboard

The keyboard on the Morrow MDT-60 Terminal (and most other terminals) is similar in many respects to a standard typewriter keyboard. However, there are some extra keys that are used to send special instructions to the computer. How the keys work depends on the software. Nevertheless, there are some keys that are commonly used by many programs and these are described below.

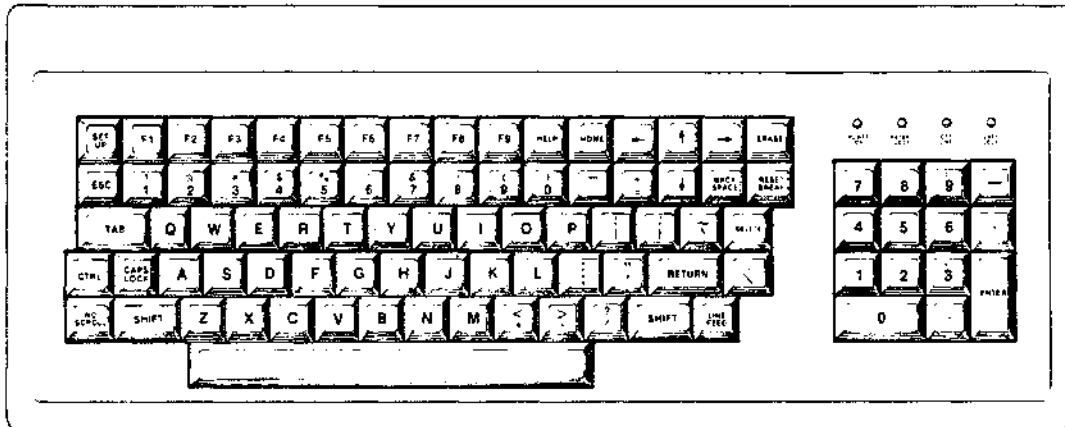

Figure B-4: Typical Keyboard

ESC Key

The use of the ESC (short for ESCAPE) key depends on the application program. In NewWord, for example, you are asked to press the ESCape key after executing certain commands. ESC is also used in the Co-Pilot Menus to back up to the previous menu, or to escape out of the menus to CP/M.

CAPS LOCK Key

The CAPS LOCK key (also called ALPHA LOCK or ALL CAPS key) is like the shift lock key on a typewriter. It causes all letters typed to be in upper case. It has no effect on the number or punctuation keys, however.

Normally you press CAPS LOCK once to activate all caps, and again to de-activate them. Some keyboards deactivate CAPS LOCK when you press the SHIFT key.

SHIFT Key

The SHIFT key works like the shift key on a standard typewriter. To type an upper case letter (or a symbol above a number key), hold down the SHIFT key and type the letter or number.

CTRL Key

The CTRL key (short for CONTROL) is always used in conjunction with another key to send a special command to your computer. Your keyboard has 26 letter keys (A through Z). The CTRL key can be used with these to add an additional 26 "keys" to your system. It can also be used with some of the symbols, for a total of 32 "keys".

The CTRL key is used just like the shift key. When you are asked to enter CTRL A, hold down the CTRL key and press the A key. The CTRL key is sometimes referred to by the "^" symbol. If a manual or help menu tells you to press ^A, it is asking you to press CTRL A, not the caret symbol that often appears on the 6 key.

You will find the CTRL key especially important when you begin using NewWord. To delete a word, for example, the NewWord manual instructs you to type ^T. In this case, you hold down the CTRL key and, without releasing it, press T. Although this may sound cumbersome, it is very easy to get used to.

BACK SPACE Key

The BACK SPACE key is used both to back over characters and to erase characters. Both these functions depend on the program you are running at the time. In NewWord, for example, pressing the BACK SPACE key will back the cursor over the characters, but will not erase them. Under CP/M, however, BACK SPACE erases characters as it backs up, just like the DELETE key.

DELETE Key

The DELETE key (sometimes called the RUB OUT key) is used in CP/M and most application programs to back over and erase characters. ..@i Program, executing

RETURN Key

The RETURN key (sometimes called the ENTER key) is somewhat like a carriage return on a typewriter, but has additional uses. When doing word processing, for example, it is used to end a paragraph. In most cases, the RETURN key must be pressed to execute your command; in fact, many programs do not recognize commands until the RETURN key is pressed. That's why it is sometimes called the "ENTER" key - it is used to enter commands.

NO SCROLL

This key has the same effect as CTRL-S and CTRL-Q. These Control key codes freeze text that is scrolling up your screen, usually after a CP/M "type" command. NO SCROLL makes it stop just like CTRL-S does. Pressing NO SCROLL a second time resumes the scrolling, like CTRL-Q.

Numeric Key Pad

Many terminals have a numeric key pad which is similar to an adding machine or calculator key pad. This pad is handy when using programs that require a substantial amount of numeric entries. The keys on the numeric key pad can be used interchangeably with the number keys above the letters on the keyboard. Also, its ENTER key is exactly the same as the RETURN key.

Special Symbol Keys

There are several special symbol keys on your Morrow terminal (and most other terminals) that do not appear on standard typewriters, and there are common symbols which serve double duty on a computer. These symbols are used in languages and programs for arithmetic functions. These are covered in the manuals that accompany BASIC, LogiCalc and other languages and programs that use such symbols. Although their use can vary, the following table illustrates some common symbols and their definitions:

<u>SYMBOL</u>	<u>RESULT</u>
<	Less than
>	Greater than
+	Addition
-	Subtraction
*	Multiplication
/	Division
=	Equals

Function Keys

Function keys are a complicated matter. Normally, you need an extra piece of software that translates the actual code sent out by a function key (F1, F2, etc.) into something meaningful. For example, you might want F1 to mean "delete a line" when you run NewWord. The software would translate F1's code into CTRL-Y in this case. "Smart Keys" is the name of one such program.

Software is currently being written for the Morrow MDT-60 and MT-70 that will allow you to program each of the function keys to send out any text or command you want. Each key will can have three values: one when typed by itself, another when it's used with the SHIFT key, and a third when used with the CTRL key. Furthermore, their meanings can be tied to a certain program, that is, they can have three meanings while NewWord is running, and three others while using LogiCalc. Instructions for defining the keys will be provided when you get your Quest/Backfield update diskette.

Cursor Keys

We can't promise anything about terminals other than the MDT-60 and MT-70. In these terminals, the cursor keys (the ones with arrows on them) are just like function keys with arrows. They will be programmable to mean whatever you please. With thirteen function keys and four cursor keys, and a potential of three definitions each (per application program), this makes a total of 51 user-programmable functions for each program.

-- (*) --

APPENDIX C

----- GLOSSARY

ALLOCATE - Assignment of space or function for a specific task. Usually applied to memory or disk space.

APPLICATION PROGRAM - Usually a commercially available program that tells the computer how to do a specific job, such as word processing or payroll accounting.

BACK UP COPY - A copy of files (programs or data) kept as a spare in case the original file is destroyed.

BAUD RATE - Rate of character transmission speeds over asynchronous communication devices such as printers, terminals and MODEMs. Named for Emil Baudot, a pioneer in printing telegraphy.

BIT - A contraction of "binary digit;" the basic unit of information used by the computer. Eight bits equals one byte (see BYTE).

BOOT - Short for "bootstrap." A bootstrap program contains instructions that allow the computer to be placed in a desired state by means of its own actions. Microcomputers are readied for use by a bootstrap program (see COLD START).

BYTE - The representation of a single character. A sequence of eight bits treated as a single unit; also the smallest addressable unit within the system.

CAPACITY - Amount of data that can be stored on a magnetic storage device (diskette, for example); usually described in terms of k bytes, where one k = 1024 bytes.

CHARACTER - Synonymous with byte. One character is made up of 8 bits.

CHIPS - Small (about 3/8 inch square) pieces of silicon that contain computer logic and circuitry for processing, memory and input/output functions. Chips are soldered together on a printed circuit board to form the microcomputer.

COLD START - Procedure to start up a computer that is currently off or has undergone a serious failure. The Micro Decision> uses a bootstrap program to bring itself up (see BOOT).

COMMAND - Instruction entered by the user at the terminal keyboard to direct the actions of the computer.

COMPATIBILITY - The ability of one computer to accept and process data by another computer without modifying the data or the media upon which it is being transferred.

COMPUTER PROGRAM - A set of instructions written for a computer that enable it to achieve a desired result.

CONFIGURATION - A group of devices (such as terminals, printers, disk drives, etc.) connected to a computer that has been programmed to operate them as a single system.

CONTROL KEYS - Key or a sequence of keys entered at the keyboard to initiate a particular function within a program.

CPU - Central Processing Unit. The "brains" of the computer where instructions and data are interpreted and executed.

CURSOR - Indicates position on the terminal screen; may be a small rectangle, line or triangle.

DATA - The facts, numbers, letters, symbols, etc. processed or produced by the computer.

DISK STORAGE - Storing of data on magnetic disk. Data is arranged on concentric tracks much like a phonograph record.

ERASE - Complete removal (obliteration) of data from a disk or other data storage device.

EXECUTE - The process of entering a command that the computer can successfully perform or carry out.

FILE - A single named collection of data, such as a manuscript or a list of addresses, that can be recalled by the computer.

FIRMWARE - Specific software instructions permanently placed into the computer's internal memory chips.

FLOPPY DISKETTE - Small, flexible disks that store magnetically encoded data used on the microcomputer.

FORMAT - Structure of a diskette that the operating system expects before it writes files or programs onto the diskette.

HARDWARE - Contrasts to software; the physical computer equipment and components, such as the magnetic, electronic and mechanical devices.

INPUT - Data entered into the computer to be processed from the keyboard, or the transfer of data from external storage to internal storage devices.

I/O - Input/Output; refers to acceptance and transfer of data to and from a computer.

I/O DEVICES - Devices used to communicate with the computer and transfer data to and from it.

INSTRUCTION - Statement in a computer program specifying a particular function or task to be performed.

k - Taken from Greek word "kilo" meaning 1000; equivalent to 1024, or 2 raised to the 10th power (see BYTE).

LANGUAGE - A means of conveying information to the computer that is governed by a set of defined rules and conventions.

MASS STORAGE - On-line secondary data storage devices, such as hard disk subsystems, that are readily accessible by the CPU.

MODEM - Contraction of MODulator-DEMODulator; communication device that transmits information between computers via telephone lines.

OPERATING SYSTEM - An operating system has many important functions in a computer system. It is a collection of instructions and software programs that link the user to the computer, allowing him to work efficiently with it. It also controls the operation of the system, taking care of command and program execution, displaying error messages at the appropriate times, directing data to the proper places, etc. The Micro Decision operates with the CP/M operating system.

PRINTER - An output device that produces a "printout" or "hard copy" of computer data. Output is measured in the amount of words printed per second, with dot matrix printers being faster than letter quality printers.

RAM - Random Access Memory; high speed memory locations within the computer circuitry itself.

RS-232 - A specification established by the Electronic Industries Association governing the interface requirements between MODEMs and terminals or computers.

SOFTWARE - The programs that govern the operation of the computer and make the hardware run.

TERMINAL - A typewriter-like keyboard and CRT (cathode ray tube) display screen connected to the computer for input/output of data.

USER - Person who uses a computer.

WARM START - Restarting or resetting a computer after a temporary failure or interrupt of normal activity; temporary failure has not disturbed back up storage.

-- (*) --

Consider this booklet your tour guide. It is written for people like yourself who have chosen Morrow's MD-11, 11-megabyte hard disk CP/M computer system. It is meant to get you started with the MD-11, and to show you some good maintenance habits. It does not teach you how to use your software (NewWord, Personal Pearl, etc.), since these are covered in their own manuals.

We want to get you hooked up and running right away. So, if you're a complete newcomer to Computersville, you may want to skim Appendix B for a few fundamentals like how to handle diskettes. Appendix A lists the MD-11's general specifications.

NOTE: Early versions of the MD-11 software assume you are using a Morrow MDT-60 terminal. The first page of Chapter 1 and Appendix E are written for software versions that don't make this assumption. Whichever version you have, this manual will still apply.

We apologize for the absence of an index in this Highly Preliminary version. Your humble narrator was too busy checking the accuracy of the manual and programming your Co-Pilot menus to get the index ready in time for duplication on Morrow's overworked Kodak 250. The section titles should be descriptive enough that the table of contents will lead you to the information you seek. Thanks for understanding.

-- (*) --

APPENDIX D

----- CONNECTING DEVICES TO THE MD-11

Figure D-1 shows the connectors on the rear of the Micro Decision. Each connector is designed to have a certain type of device attached to it. This appendix tells you what connects where, and details the options that are available to make the Micro Decision compatible with a healthy variety of devices.

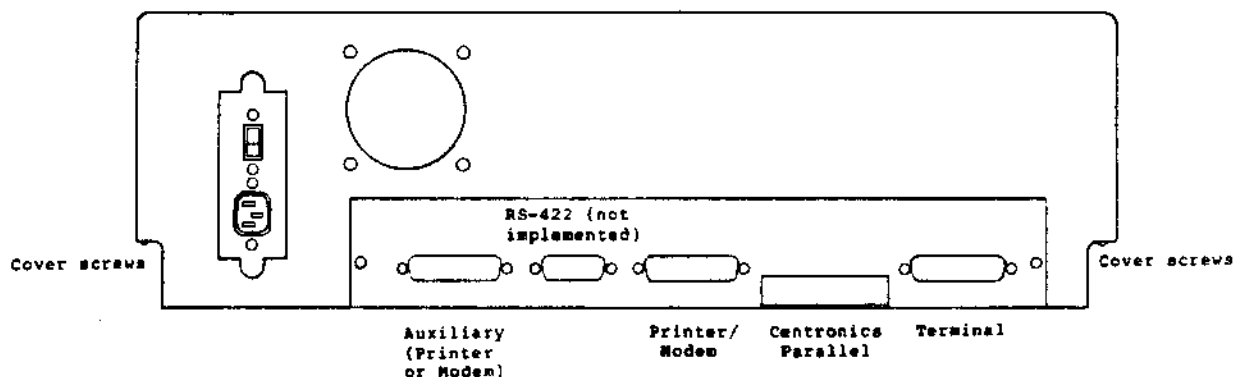

Figure D-1. MD-11 peripheral connectors

The topics that will be discussed herein are:

- o Serial versus Parallel transmission
- o RS-232 standard connections
- o Centronics-style printer connections
- o Baud rates and communication protocols
- o Using two printers
- o The SETUP program, which controls baud rates, protocols, and printer selection
- o Using jumpers to configure the Micro Decision for modem hookups
- o Technical data on the serial ports and CP/M device definitions

Types of Transmission

There is a direct relationship between the two classes of data transmission mentioned above and the two different styles of printer connectors on the MD-11.

The "lazy D" sockets with 25 little holes in them are known as serial ports. The flat plate with the gold stripes on it is a parallel port, designed to connect to a parallel printer that conforms to the standards established de facto by the Centronics Corporation.

Now then. If you don't know the difference between serial and parallel transmission of data, you may find the rest of this section enlightening. The information presented is not essential to making the proper connections, though.

Serial transmission means that a letter or number is sent, say, from your terminal to the Micro Decision in a burst of eleven bits, one after the other. The bits are represented by a voltage going up and down on one of the wires that connects the Micro Decision to its serial peripherals.

The first bit is the "start bit", which alerts whoever is receiving to get ready for the next ten bits. The eight bits after the start bit form a code that represents a letter, number, or special character. The last two bits are "stop bits" that say that the character is finished. (There are variations on this theme, but they go beyond our discussion since they don't apply to the Micro Decision.)

The Micro Decision normally talks to its terminal at 9600 baud, which translates to 9600 bits per second. At 11 bits per character, this boils down to a transmission rate of about 870 characters per second. This speed can be changed to meet the needs of certain terminals, as will be covered when we get to the **SETUP** program.

Terminals and modems always converse with the Micro Decision over serial links; printers, however, may employ serial or parallel schemes.

Parallel transmission takes place when a whole character is sent to and from the computer as a unit, instead of one bit at a time. Of course, you need at least eight wires to carry the individual bits that make up a character, so you'll find that parallel cables are generally more bulky than serial cables. This also explains why the connectors themselves have to be different.

A printer may come with a serial interface, a parallel interface, or both. Printers that are strictly parallel may be cheaper than their serial counterparts because fewer components are involved in processing parallel signals.

Serial transmission does have some definite advantages, however, such as the relative simplicity of the cables. Another is the greater distances that serial communication can reliably cover. But the biggest difference is the fact that the RS-232 serial interface was designed to accommodate two-way communication while the centronics parallel interface is limited to one-way. Hence the latter's employment for printers only.

The RS-232 Connectors

RS-232 is a standard adopted by the Electronic Industries Association that defines, among other things, which of the pins in the 25-pin serial connector carries what signal. These signals are identified later in this appendix under Jumper Options.

When you face the rear of the Micro Decision, the rightmost serial connector is where you attach your terminal. The next connector (labelled PRINTER/MODEM) is available for serial printers, modems, plotters, or networking to other computers. This connector comes configured from the factory for use with printers. There are jumpers inside the Micro Decision that enable it to work with other devices, which we will get to momentarily.

The Centronics Connector

The 34-pin edge connector is a unidirectional parallel port designed for use with centronics style printers. You will need an adapter cable that connects the edge connector to the standard 36-pin centronics port on the printer. This cable is available from Morrow or at Radio Shack.

Unlike with the serial connectors, it is possible to connect the adapter cable to the edge connector upside down. While no harm results, no good does either. You can be sure that it's right when the ribbon of wires is flowing downward out of its connector (see Figure D-2).

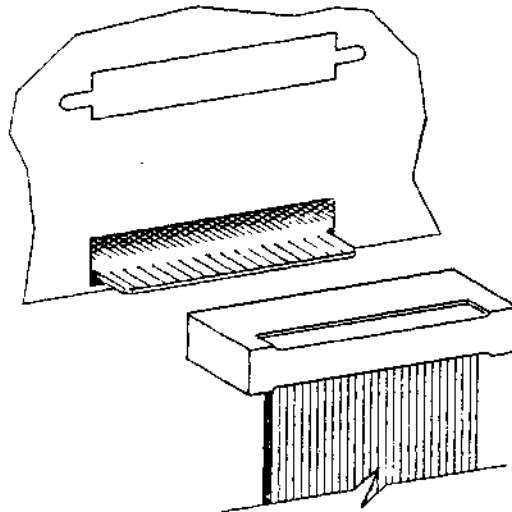

Figure D-2. Connecting the 34-pin plug

The AUXILIARY Connector

This is an additional RS-232 port that is not currently used by the MD-11 software. Programmers can make use of it, but they have to write their own drivers for it. The Morrow MM300 Modem software "ReachOut" and "MicroEZLnk" use this port for the modem, in case you have another serial device attached to the PRINTER/MODEM port. The pamphlet "Micro Decision Questions and Answers" contains technical data on the AUX port.

The RS-422 Connector

This connector has the same input/output address as the AUX port next to it. It is designed for high speed synchronous communication with other machines, particularly mainframe computers. Morrow's CBIOS makes no use of this port at the present.

Crash Course in Baud Rates and Protocol

Baud Rate is the speed at which data flows across a serial communications link. Protocol, also known as "handshaking", is the system by which the computer and peripheral let each other know if they're ready for data or whether they're too busy at the moment.

There are two basic types of protocol, hardware handshaking and XON/XOFF (software handshaking). XON/XOFF applies only to serial printers. Parallel printers always use hardware handshaking.

The only judgment you have to make in this regard is whether your serial printer is capable of using XON/XOFF handshaking. This should be clear from the dealer or from the printer's documentation. If it does have this capability, great. If not, this is no problem, but you must make sure that your printer cable has a wire in it connecting pin 20 at the Micro Decision end to the Busy/-Ready pin at the printer end.

The pin number at the printer end varies among brands of printers, so you'll have to check its manual. Typically it is either pin 4, 11, 19, or 20. If a cable is not available off the shelf to meet your needs, you can make one from parts available at Radio Shack or have your dealer make one. Keep in mind that if your printer can use XON/XOFF handshaking, none of this cable business applies.

The main thing you need to know about the details of baud rate and protocol is that they must be set up symmetrically in the computer and its peripherals. Which brings us handily to the SETUP program.

The SETUP Program

This is a CP/M program that modifies the operating system to reflect these factors:

- A) **The baud rate for your terminal** - If you have a terminal that operates at something other than 9600 baud, or if you are connecting a modem to this port (unusual), you can select 110, 300, 600, 1200, 2400, 4800, or 19200 baud, and later return to 9600.
- B) **Printer Selection** - More will be said about this below, but for now this means you have a fairly convenient way of sending output from an application program to the serial printer one time and to the parallel printer the next.
- C) **The serial printer baud rate** - This comes preset at 1200, but you can change it to any of the values listed in "A)" above.
- D) **Serial printer protocol** - This is where you specify hardware or XON/XOFF handshaking. The Micro Decision assumes you are using hardware handshaking unless you use SETUP to tell it otherwise.

You have the option of making these changes take effect immediately, in which case they stay in effect only until you reboot. The alternative is to make the changes permanent on the CP/M disk so that they are in effect from your next boot until you run SETUP again.

Using SETUP

To get SETUP running:

1. Escape from the menu system by pressing the ESC key at the Co-Pilot Main Menu.
2. At the "A>" prompt, type `setup` and press RETURN. The screen in Figure D-3 follows.

To make changes via SETUP:

Study the screen and locate the change(s) you want to make. Pressing the letter key associated with a function will "toggle" the value of that function. For example, if you press A repeatedly, the displayed terminal baud rate switches from 9600 to 110 to 300 and so on, continuing the cycle each time you press the key.

Each of the functions A-D operates in this way, with its own options as noted previously. After you have made all of the changes necessary, press E to put the changes into memory (the immediate and temporary route), press F to write the changes into the appropriate hard disk file (CPM3.SYS - the deferred but permanent route), and then press ESCape to return to the A> prompt.

This program allows you to change the operating characteristics of your Micro Decision. The changes can be made temporarily or permanently.

A) Terminal speed 9600 baud	C) Printer / modem speed 1200 baud
B) Printer connection CENTRONICS PARALLEL	D) Printer / modem protocol HARDWARE HANDSHAKING ON PIN 20

E) Make temporary changes effective immediately
F) Save changes on disk for use after next boot
ESC) Quit without making any further changes

Selection: []

Figure D-3. The SETUP menu

Example: You got a new serial printer that uses XON/XOFF handshaking and runs at 2400 baud. This is your first run of SETUP, that is, it is still set to its default settings.

1. Get into SETUP as described above.
2. Press C once to toggle it from 1200 to 2400 baud. If you accidentally go past 2400, keep typing C; it will be back.
3. Press D to go from HARDWARE HANDSHAKING ON PIN 20 to XON/XOFF.
4. Press F to make the changes permanent on the hard disk. "Permanent" is relative, of course, because you could rerun SETUP five minutes later and change it again.
5. Press RESET to put the changes into effect.

Special Notes:

If you have only a terminal that simply can't operate at 9600 baud (very unlikely), you will have to get your dealer to run SETUP for you with his terminal and your MD-11.

When you do this, don't be surprised when "garbage" appears on your screen each time you press the reset button. This is a garbled version of the message that normally tells what revision level your ROM has. It is sent out at 9600 baud, so your terminal misinterprets it. After you finish booting however, the new baud rate takes over and everything proceeds normally from there.

This implies that you'll never be able to boot from your floppy, because your response of "Y" that tells the MD-11 to do so must be sent from your terminal at 9600 baud. But since you'd seldom boot from the floppy anyway, this will be an inconvenience only if your hard disk becomes unbootable through malfunction or abuse. Then you'd have to borrow a terminal that works at 9600.

Using Two Printers

It is conceivable that you may have both a serial and a parallel printer, with one doing high speed matrix output and the other handling slower letter-quality jobs.

Perhaps you want to send the output of a word processing program to the matrix printer, for example, until you reach the final version. Then you want to print it on the daisy-wheel.

If both of your printers are serial (or parallel) and both operate with the same baud rate and protocol, all you would have to do to switch printers is to unplug one and plug the other one in. Even when these unlikely conditions exist, this technique is still tedious and hard on your cable.

In the more probable case of two printers that are not so compatible, and without the benefits of the SETUP program, you would have to get involved in resetting switches inside the computer and possibly having to swap cables.

SETUP function B (Printer select) allows you to switch from serial to parallel printer and back effortlessly. Those of you familiar with CP/M should note that this function establishes the setting of the "LST:" device, while the printer not selected automatically becomes the "PUN:" device.

SETUP function C (Printer baud rate) is useful not only if you have a single serial printer that won't work at 1200 baud, but also if you have two serial printers operating at different baud rates. Then you can switch plugs, run SETUP, and toggle the baud rate (and protocol, if necessary). Note that you would probably want to make changes temporary (the E option) instead of permanent under these circumstances.

Jumper Options

The following operations involve removing the cover of the Micro Decision and thus should be performed by qualified technical personnel only.

Most peripheral options can be handled with the SETUP program. If you want to use a modem on either of your serial ports, however, it is necessary to reconfigure the pinouts of that port with jumpers contained on the Micro Decision circuit board.

As mentioned previously, the serial connectors on the Micro Decision conform to RS-232 standards. Figure D-4 shows the layout of the connector and Table D-1 identifies the signal associated with each of the pins.

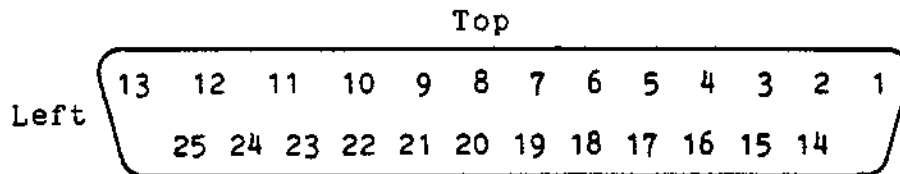

Figure D-4. Serial Port Pin Arrangement - Rear View

Pin #	Signal
1	Frame Ground
2	Receive Data Input
3	Transmit Data Output
4	Request To Send Input
5	Clear To Send Output
6	Data Set Ready Output
7	Signal Ground
8	Carrier Detect Output
9 *	+12V Output
10 *	-12V Output
11 *	Alternate Handshake Line
14 *	+5V Output
17 *	Receiver Clock Output
20	Data Terminal Ready Input
24 *	Transmitter Clock Input

* These signals are available on the printer/modem and auxiliary connectors only.

Table D-1. RS-232 Signal Descriptions

On the circuit board in front of each serial connector is a set of jumper headers labeled JPA, JPB and JPC.

JPA has 8 pairs of jumpers for defining the terminal port; JPB has 9 pairs that define the printer/modem port. JPC has 15 pairs that define the auxiliary port.

Slip-on connectors are used to make the RS-232C pin assignments. By changing the positions of some connectors, the ports can be configured for use with modems. (For those familiar with telecommunications jargon, the jumpers select whether the serial connector is set up to talk to DCE or to DTE equipment.)

ACCESSING THE JUMPERS

Before you begin, PARK THE MD-11, TURN OFF THE MD-11 POWER SWITCH and UNPLUG THE POWER CORD.

Remove the four screws securing the cover to the chassis. Carefully slide the cover towards the front (it is not necessary to remove it completely).

Each jumper block is located in front of the serial port it relates to.

JPA/JPB Factory Settings

You would configure the terminal port for a modem if you wanted to call up the MD-11 from a remote terminal or computer.

The signal present on each jumper pin in JPA and JPB is shown in table D-2 along with the factory setting for the feeding of the signals to the RS-232C connectors.

This signal configuration is accomplished through circuit board wiring and the factory jumper settings, as shown in Figure D-5.

<u>JPA/B Pin#</u>	<u>Signal</u>	<u>RS-232C Pin#</u>
(1A)	RxD to DART	2
(2A)	RD to device	3
(3A)	DSR to device	6
(4A)	DSR/ to DART	4
(5A)	DTR from device	20, 5
(6A)	DTR/ from DART	20, 5
(7A)	+12V	8
(8A)	+12V	8
(9A)*	+12V	8, 11
(9B)*	DET from device	8, 11
(8B)	CTS/ to DART	8
(7B)	CD from device	8
(6B)	CTS to device	20, 5
(5B)	CTS/ to DART	20, 5
(4B)	RTS from device	4
(3B)	RTS/ from DART	6
(2B)	TxD from DART	3
(1B)	TD from device	2

* JPB only

Table D-2: JPA/B Pinouts (Terminal Setup)

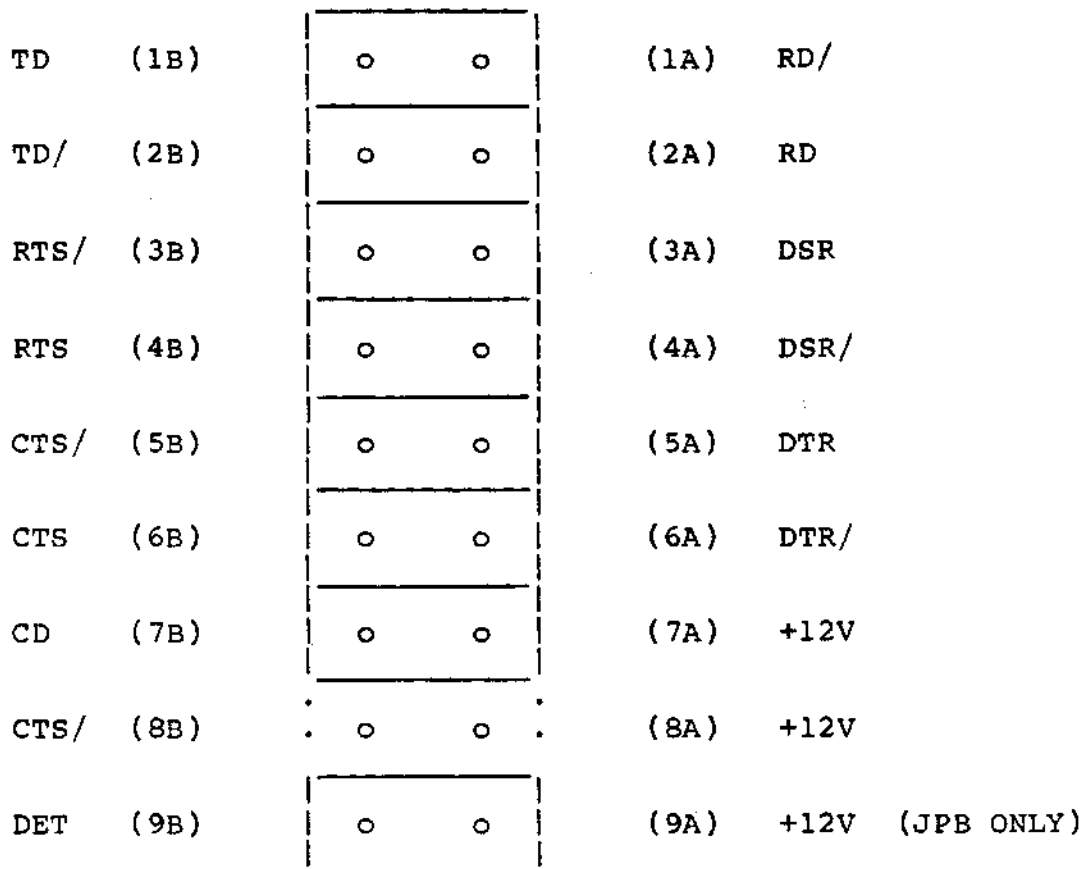
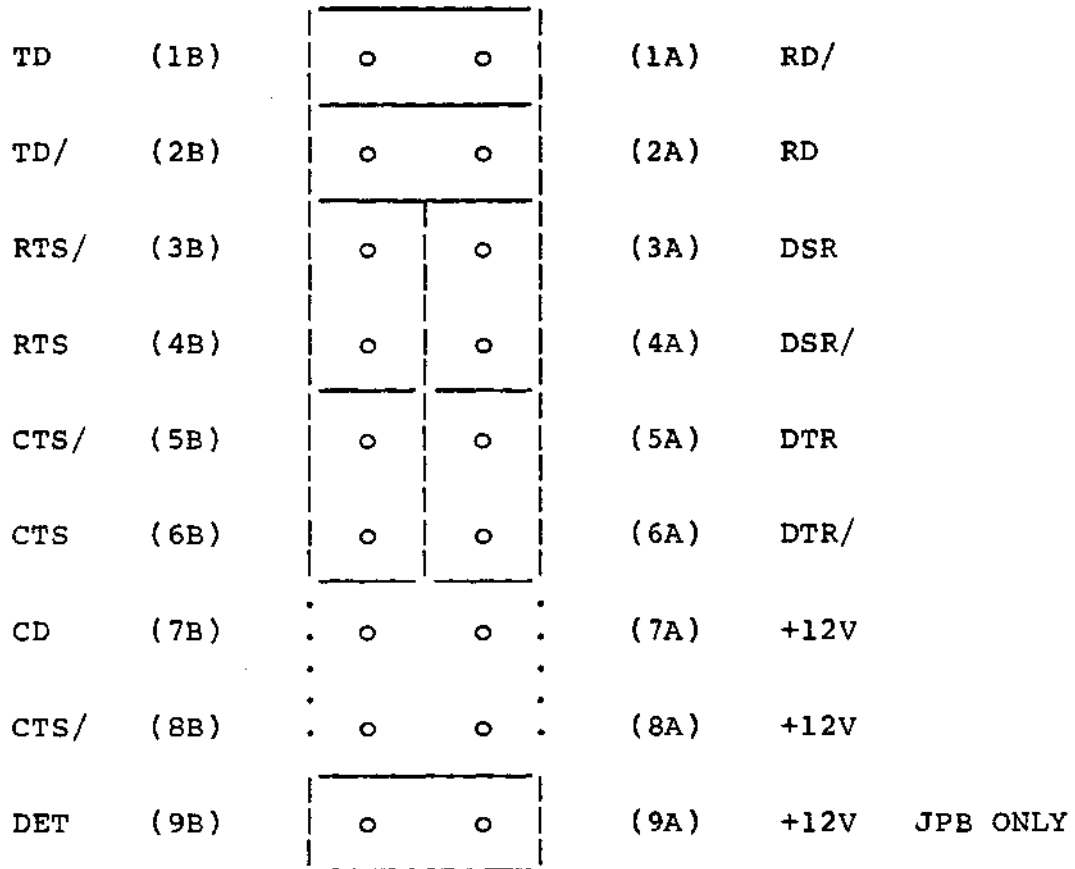

Figure D-5. Factory Jumper Settings for JPA/B

When setting up JPA or JPB for use with a modem, the jumper modifications depend on whether your modem cable has pin 2 at one end tied to pin 3 at the other, and vice versa. This crisscrossing is frequently, but not always, found in modem cables. If you're not sure which type you have, use an ohmmeter or continuity tester to find out.

JPA and JPB Settings for Modems

For cables that crisscross pins 2 and 3, arrange the jumpers as shown below.



For cables that connect pin 2 to pin 2 and pin 3 to pin 3, set your jumpers as shown in the next diagram.

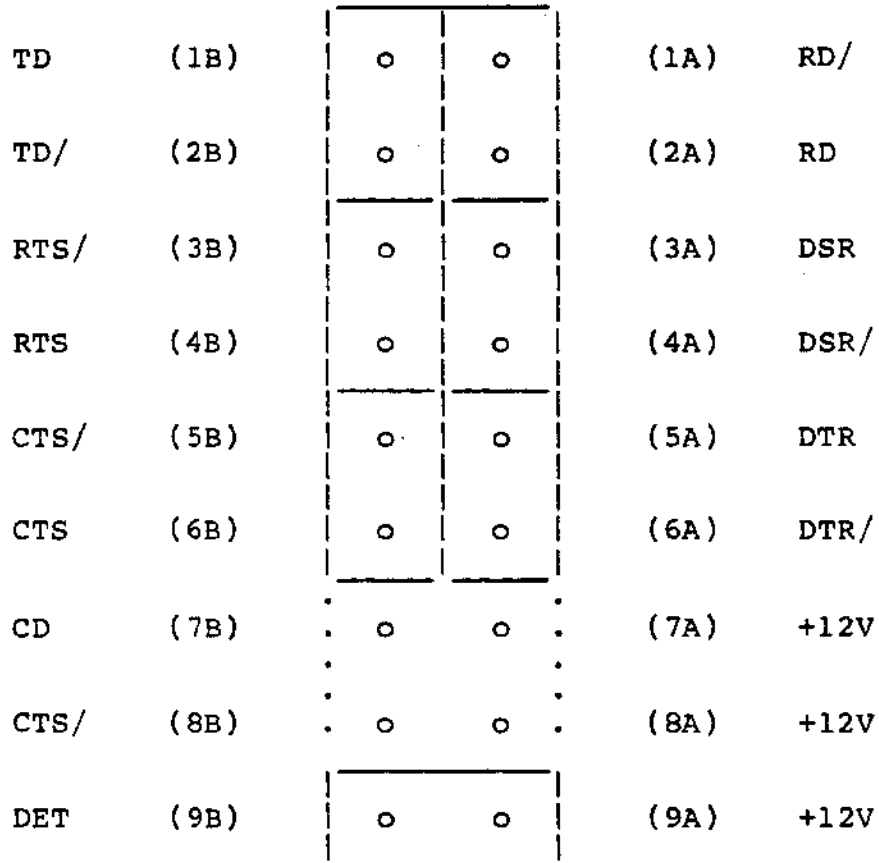

Factory Settings for JPC

The Auxiliary port would be configured for a modem if you want to use the MD-11 as a host computer contacting remote computers or data bases.

NOTE: The Auxiliary port comes from the factory configured as DTE; with most modems you have to change jumper settings on JPC as well as installing the software for this port. However, with Morrow's MM300 modem and ReachOut software, neither operation is required.

The signal present on each jumper pin in JPC is shown in table D-3, along with the factory setting for the feeding of the signals to the RS-232C connector.

The signal configuration is accomplished through circuit board wiring and the factory jumper settings, as shown in Figure D-6.

<u>JPC Pin#</u>	<u>Signal</u>	<u>RS-232C Pin#</u>
(1A)	RxD to ZSIO	2
(2A)	RD to device	3
(3A)	DSR to device	6
(4A)	CD to ZSIO	4
(5A)	DTR from device	20
(6A)	DTR/ from ZSIO	5
(7A)	TTL false (<-3V)	8,11
(8A)	TTL false	8,11
(9A)	TTL false	8,11
(10A)	Receiver clock to device	17
(11A)	RS-232 Receiver input	N/C
(12A)	TTL output of RS-232 rcvr	N/C
(13A)	Transmit clock to RS 422	N/C
(14A)	Transmit clock to ZSIO	N/C
(15A)	Transmit clock to ZSIO	N/C
(15B)	Receiver clock to ZSIO	N/C
(14B)	RS 422 receiver clock	N/C
(13B)	Baud clock output	N/C
(12B)	Rcvr clock input to ZSIO	N/C
(11B)	TC (external clock)	24
(10B)	RS-232 level clock out	N/C
(9B)	DET (alternate handshake)	8,11
(8B)	CTS/ to ZSIO	20
(7B)	CD from device	8,11
(6B)	CTS to device	5
(5B)	CTS/ to ZSIO	20
(4B)	RTS from device	4
(3B)	RTS/ from ZSIO	6
(2B)	TxD from ZSIO	3
(1B)	TD from device	2

Table D-3: JPC Pinouts (Modem Setup)

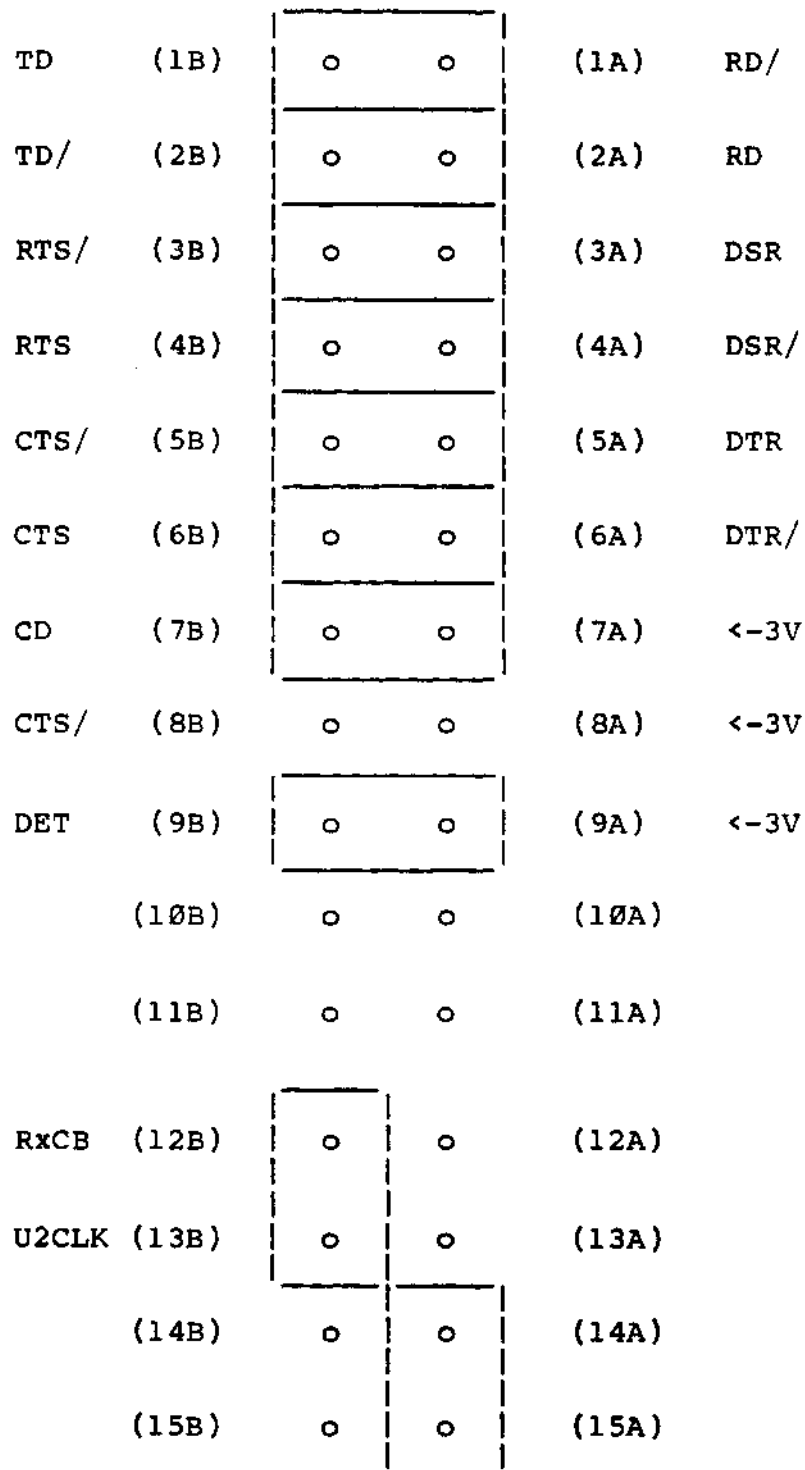
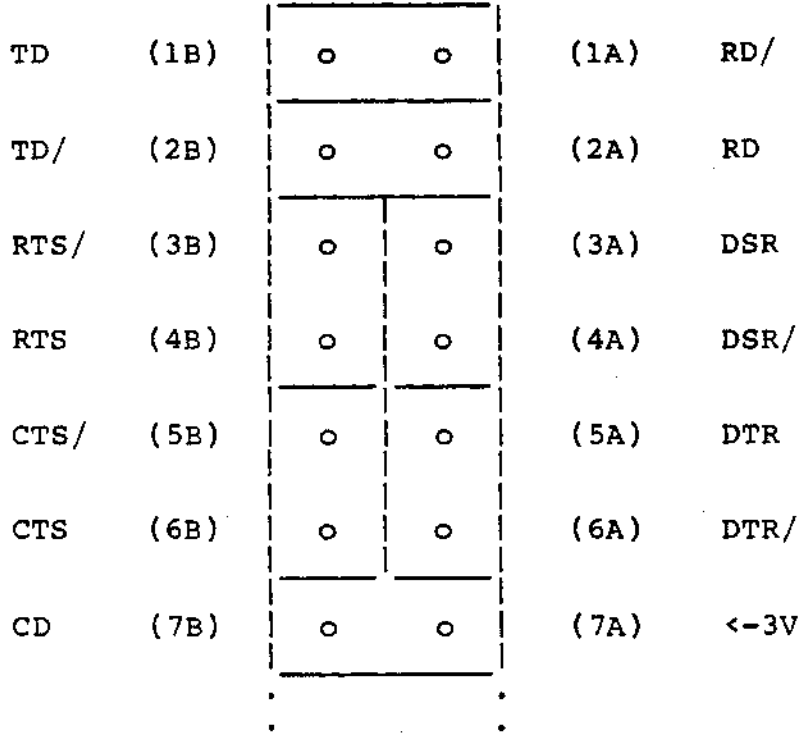

Figure D-6. Factory jumper settings for JPC

JPC Settings for Modems

Keep in mind that you don't need to reset the jumpers if you're using a Morrow Modem with its supplied software.

The jumper settings for JPC depend upon the type of modem cable you have. For cables that crisscross pins 2 and 3, arrange the jumpers as shown in the next figure.



(The rest are the same as factory.)

When using a modem cable that connects pin 2 to pin 2 and 3 to 3, the jumper setup is the same as above except for positions (1A), (2A), (2B), and (1B). See the difference below.

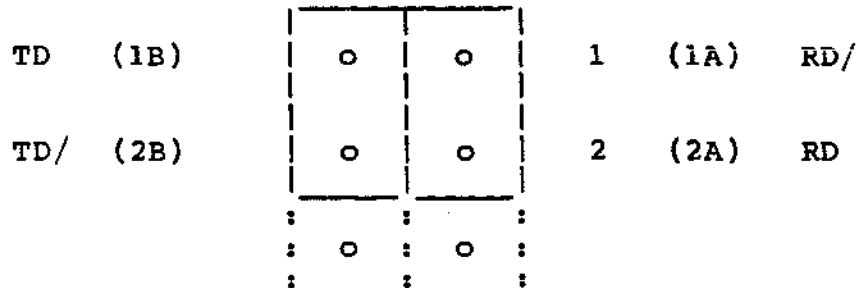

CP/M Device Definitions

The MD-11 has all four logical devices implemented as follows:

CON:	Terminal
LST:	PRINTER/MODEM port (supports XON/XOFF handshaking) or CENTRONICS port
RDR:	PRINTER/MODEM port (input)
PUN:	PRINTER port (output, supports XON/XOFF) or CENTRONICS port

The thing that determines the assignment of the LST: and PUN: devices is SETUP.COM. The printer (port) selected through this program becomes the LST: device while the other becomes PUN:. Factory settings are LST: = CENTRONICS and PUN: = PRINTER/MODEM.

Port Addresses

The DART port locations for the MD-11 are:

Terminal data port = 060H
Terminal status port = 061H
Printer/modem data port = 062H
Printer/modem status port = 063H
Auxiliary data port = 070H
Auxiliary status port = 071H

The terminal and printer/modem ports are controlled by a Zilog Z-80 DART (dual UART). The auxiliary port is controlled by a Zilog SIO (serial I/O) chip.

The bits that represent Character Ready and Transmit Ready in the controller's STATUS register are:

CHAR RDY = bit 0	TRANSMIT RDY = bit 2
------------------	----------------------

I/O Ports

The MD-11 uses all 256 I/O ports. The address lines are decoded to provide nine blocks of ports:

<u>Range</u>	<u>Name</u>	<u>Function</u>
00 - FF	IO00	Expansion bank 0
10 - 1F	IO10	Expansion bank 1
20 - 2F	IO20	Expansion bank 2
30 - 3F	IO30	Expansion bank 3
40 - 4F	LPORTS-WRITE	
50 - 5F	TIMER	8253 counter timer
60 - 6F	DART	Dual UART
70 - 7F	LPORTS-READ	

RS-422 Pin Connections

The RS-422 connector leading from the Modem port is a high speed synchronous serial port. It allows you to send to and receive information from a mainframe computer. These are how the pin connections are set:

RS-422 Pin Connections

1. Transmitted data +
2. Transmitted data -
3. Transmit clock +
4. Transmit clock -
5. Received data +
6. Received data -
7. Receiver clock +
8. Receiver clock -
9. Ground
10. Ground
11. Ground
12. Ground
13. Ground
14. Ground
15. Ground

The Expansion Connector

While you had the cover off of the Micro Decision, you may have noticed J5, a 40-pin connector near the disk drive connectors. This is intended for future use as a connector to circuit boards that provide enhancement functions, such as a networking board. Documentation for its pinouts will be available when it becomes operational.

- A - to Abort, 5-5
- A> prompt, 2-11, 2-19, 4-2, 4-15
 - See also CP/M prompt
- Adding new software, 4-9
- Allocate, C-1
- Application programs, 3-1
 - running from CP/M, 4-18
- Arithmetic functions, B-11
- Arrow keys, B-12
- Attributes, 2-13
- AUXILIARY
 - See Connectors

- Back panel connections, A-6
- BACK SPACE Key, B-10
- Back up copies, C-1
- Backfield Working Diskette, 3-11
- Backfield, first use of, 2-9
- BACKUP program, 3-6
- BACKUP.DSK file, 3-6
- Backups
 - See Backfield
- Badmapping, 5-4
- BAK (NewWord backup) files, 2-20
- BASIC and BAZIC, 2-10
- Basic Training in CP/M, 2-21
- BASIC, running from CP/M, 4-18
- Baud rate, 1-9, D-2, D-5
 - defined, C-1
 - serial printer, 1-16
 - SETUP options, 3-4
- BAZIC, running from CP/M, 4-18
- Binary digit, C-1
- Bits, C-1
 - defined, C-1
- Boot, C-1
- Booting from a floppy, 1-14, 3-10, 4-3
- Booting the system, C-1
- Booting
 - automatic commands, 3-5
 - cold vs warm, 4-6
 - defined, 4-5
- Bugs, 5-1
- Bytes, B-3, C-1

Cables

- printer, 1-6
- terminal, 1-5
- Calculator key pad, B-11
- Capacity, C-1
- CAPS LOCK Key, B-9
- Central Processing Unit (see also CPU), B-3
- Centronics connector, D-4
- CENTRONICS PARALLEL
 - See Connectors
- Centronics port, D-2
- Characters (see also Bytes), B-3, C-1
- Check Space and File Size, 2-17
- Chips, C-1
- Circuit board, C-1
- Co-Pilot Main Menu, 1-13, 2-2, B-9
- Co-Pilot menus
 - disabling, 3-6, 4-4
 - general description, A-7
 - restoring, 4-5
 - translating into another language, 4-13
- Co-Pilot Utility Menu, 2-12
- Cold start, C-2
- Command
 - defined, C-2
 - executing, B-9, C-2
- Communication devices
 - (see also I/O device), C-1
- Compatibility, C-2
- Compatibility with foreign formats, A-7
- Computer program, C-2
- Computer system, A-1
- Configuration, defined, C-2
- Connectors
 - AUXILIARY, A-6
 - CENTRONICS PARALLEL, 1-7, 3-4
 - keyboard, 1-6
 - PRINTER / MODEM, 1-8, 1-15, 3-4, A-6
 - RS-422, 4-16
 - SETUP options, 3-4
 - TERMINAL, 1-5, A-6
- Control key commands, B-10
- Control keys, C-2
- Control Program for Microcomputers (see also CP/M), A-1
- CONTROL-C command, 2-7, 2-14, 2-18
- CONTROL-J command, 4-8
- CONTROL-L command, 4-9
- CONTROL-M command, 4-8
- CONTROL-P command, 4-8
- CONTROL-Q command, 2-14

CONTROL-S command, 2-14
Copy a File or Files, 2-15
Copying whole diskettes, 4-11
COPYSYS program, 3-9
Correct-It, 2-6
 running from CP/M, 4-18
CP/M Distribution Diskettes, 1-14
CP/M prompt, 2-19, 4-2
CP/M utilities, 3-1
CP/M
 .COM file commands, 3-12
 basic training, 2-21
 entering command from Utility Menu, 2-18
 escaping to, 2-11
 learning about, 4-18
 operating system, A-1, C-3
 returning to menus, 2-12
 running application programs from, 4-18
 software available for, A-7
CPM3.SYS file, 3-10
CPM3F.COM file, 3-10
CPU, B-3, C-2
CRT, C-4
CTRL key, 2-7, 2-14, B-10
 See also CONTROL commands
Current drive, 2-19, 4-2
Current user number, 2-19, 4-2
Cursor, 1-11, C-2
Cursor keys, B-12

Data, B-3
Data Address CRC Error, 5-3
Data defined, C-2
 erasing, A-5
 exchanging, A-6
 explained, B-2
 permanent storage of, C-2
 storage device, C-2, C-3
 transfers, C-2, C-3
DELETE Key, B-10
Destination diskette, 3-7
DIR command, 2-18, 3-1
Directories, 2-5, 2-12, 3-1
 displaying from Utility Menu, 2-13
 interpreting, 2-13
DIRS command, 2-12
Disabling the menus, 4-4
Disk drive letters, 4-2, 5-6, B-4

- Disk drive
 - cable, 5-2
 - door, 5-2, B-8
 - latch, B-8
 - not ready, 5-2
- Disk Read Only, 5-6
- Diskette storage, C-2
- Diskette
 - accessing data on, 5-2
 - bootable, 3-9
 - care of, A-5
 - compatible formats, A-7
 - distribution, 5-2
 - duplicating, 3-7, 4-11
 - faulty, 5-5
 - floppy, B-3
 - formatting, 2-9, 2-16, 3-3
 - formatting for MD-2, 2-16
 - improperly formatted, 5-2
 - in foreign formats, 3-7
 - Micro Decision format, A-5, A-7
 - single vs double sided, 3-3
 - source and destination, 3-7
 - type needed, 2-9
 - where to buy, A-5
- Disks (see also Diskette), B-3
- Disks
 - logging onto, 4-2
 - See also Hard Disk
- Display a Directory, 2-13
- Distribution Diskettes, 1-14
- Drive letters, 4-2
- Drive Not Ready, 5-2

- EIA standards, C-4
- ENTER key, B-11
- ERA command, 4-12
- Erase
 - defined, C-2
- Erasing
 - characters, B-10
 - data, A-5
- files, 4-12
- Error control codes, 5-3
- Error messages
 - translating, 4-14
- Error recovery
 - A, 5-5
 - I, 5-5
 - R, 5-4

Hardware

- adding new, 4-16
- arranging, 1-4
- defined, B-1, C-3
- general information, B-3
- general specifications, A-3
- optional, A-6

Help level in NewWord

- changing, 4-6

Hewlett Packard format, 3-7

I - to Ignore, 5-5

I/O

- defined, C-3
- devices, A-6, C-2, C-3

IBM-PC format, 3-7

Information (see also Data), B-3

Information services

- CompuServe, A-6
- The Source, A-6

INIT program, 3-8, 4-17

Input, defined, C-3

Installation programs, 3-8

Installing NewWord, 4-6, 4-17

Instruction, defined, C-3

K bytes, C-1, C-3

KayPro format, 3-7

Keyboard, B-9, C-2, C-4

- arrow keys, B-12
- control keys, B-10
- cursor keys, B-12
- function keys, B-12
- general description, B-9
- installing, 1-6
- layout, B-9
- numeric key pad, B-11
- special symbol keys, B-11

Keys

- ALPHA LOCK, B-9

- BACK SPACE, B-10

- CAP LOCK, B-9

- CTRL, B-10

- DELETE, B-10

- ENTER, B-11

- ESC, B-9

- RETURN, B-11

- RUB OUT, B-10

- SHIFT, B-10

- SHIFT LOCK, B-9

Errors

- CP/M commands, 2-18
- Data error, 5-3
- Data Not Found, 5-2
- disk, 5-1
- Disk Read Only, 5-6
- Drive Not Ready, 5-2
- Equipment Failure, 5-3
- File Read Only, 5-6
- hardware failure, 5-4
- ID Address CRC, 5-3
- incorrect format, 5-4
- Media Failure, 5-3
- nonrecoverable, 5-6
- operator, 5-1
- possible responses, 5-4
- RAM and ROM, 1-12
- Seek, 5-4
- Select, 5-6
- software, 5-1
- Summary, 5-7
- Unable to Remap, 5-4
- Unknown Error Code, 5-4
- Write Protected, 5-2
- Wrong track, 5-4
- ESC key, 2-11, B-9
- ESC: Exit to CP/M, 2-11
- Execute, C-2
- Execute a CP/M Command, 2-18
- Executing commands, B-9
- Expansion connector, D-23
- Extensions, 4-1, 4-13

- File attributes, 2-13
- File cabinet screen, 2-4, 2-6
- File names, 2-13, 2-20
 - examples, 4-1
 - rules, 4-1
- File Read Only, 5-6
- File type, 4-1, 4-13
- File
 - defined, C-2
 - explained, B-2
- Files
 - copying, 2-15
 - erasing, 2-20
 - read only (see also SET), 5-6
 - renaming, 2-20, 4-14
- Firmware
 - defined, C-2

Floppies (see also Diskette), B-3
Floppies

- care and feeding, B-5
- checking available space, 2-17
- formatting, B-6
- general description, B-5
- inserting, B-8
- labelling, B-6
- storing, B-6
- write protecting, B-7

Floppy disk drives
safeguards, 1-10

Floppy diskette
defined, C-3

Floppy
booting from, see Booting

FOREIGN program, 3-7, 4-11

Format a Diskette, 2-16

FORMAT program, 2-16, 3-3

Format
defined, C-3
Micro Decision, A-7

Formats
compatible, A-7

Formatting diskettes, B-6
single vs double sided, 3-3

FULLBACK program, 2-9

Function keys, B-12

Glossary, C-1

Handshaking, D-5
see Protocol

Hard disk
adding new software, 4-9
backups See Backfield
badmapping, 5-4
care and feeding, B-4
checking available space, 2-17
checking condition of, 3-11
damage in transit, 3-10, 4-4
errors, 4-4
formatting, 3-3
general description, A-1
heads, 2-10
parking, 2-10, 3-3
storage capacity, A-2

Hardware failure, 5-3

Kilobytes, B-3

Language

compatible, B-2

defined, C-3

explained, B-2

Letters for disk drives, 4-2, B-4

Levels of terminals, 3-8, 4-17

LOAD program, 3-10

Logging onto disks, 2-3, 4-2

LogiCalc, 2-6

 exiting from, 2-6

 running from CP/M, 4-18

Main Menu

 See Co-Pilot

Manuals

 CP/M User's Guide, 2-19

 NewWord User's Guide, 4-6

 software, 2-3

Mass storage, defined, C-3

MDINST.PIL file, 4-14, 4-18

MDT-20, setting up, 1-9

MDT-60

 connecting the keyboard, 1-6

 setting up, 1-9

Memory test, 1-11

Menus

 returning to from CP/M, 1-16, 2-12

 See Co-Pilot

MICRO.PIL file, 4-13

MODEM, D-10

 defined, C-3

 RS-232 interface for, A-6

 software for, A-6

Naming files, 4-1

 See also File names

NewWord, 2-3

 customizing, 4-6

 exiting from, 2-5

 installation, 1-2

 Opening Menu, 2-5

 running from CP/M, 4-18

 sample documents, 2-5

Not Found, 5-2

Numeric entries, B-11

Numeric Key Pad, B-11

NWINSTAL program, 4-6, 4-17

ON-LINE switch, 1-16
Operating system, B-1, C-3
Osborne format, 3-7

Parallel port, D-2
Parallel Printers, 1-7
Parallel transmission, D-3
Parity, 1-9
Park program, 2-10, 3-2
Parking area, 2-11
Personal Pearl, 2-7
 exiting from, 2-8
 running from CP/M, 4-18
PILOT language, A-1
PILOT program, 3-4
PIP command, 2-14, 2-15, 3-10, 4-8, 4-10, 4-12
Ports, see Connectors
 addresses, D-21
Power cords, 1-10
Power requirements, 1-11
Power switch, 1-10
PRINTER / MODEM
 See Connectors
Printer connections, A-6
Printer
 dot matrix, A-6, C-4
 letter quality, A-6, C-4
Printers
 adding new, 4-16
 Centronics See Parallel printers
 communication specifications, 1-15
 compatibility with MD-11, 1-2
 installing, 1-6, 1-7
 parallel, 1-6
 serial, 1-6
 serial setup, 1-14
 serial vs parallel, 4-16
Printing and typing simultaneously, 4-7
Printing, aborting, 4-15
PROFILE.SUB file, 3-5, 4-4
Program
 application, A-1, A-7, B-2, B-10, C-1
 communication, A-7
 explained, B-2
 LogiCalc, B-11
Programming language
 BASIC, B-11
 PILOT, B-2

Protocol, D-5
 serial printer, 1-16
 SETUP options, 3-4

Quest, 2-8
 exiting from, 2-8
 running from CP/M, 4-18

Questions and Answers, 4-1

R - to Try Again, 5-4

RAM, B-3, C-4

RAM error, 1-12

REN (rename) command, 4-14

Rename or Erase a File, 2-20

Renaming files
 reasons for, 2-20

RESET button, 1-12, 1-14, 2-1, 2-5, 4-5
 when and when not to use, 4-15

Resetting
 See RESET Button

RETURN Key, B-11

ROM error, 1-12

RS-232, D-3
 defined, C-4

RS-422 port, 4-16

RW (read/write) attribute, 2-13, 2-17

Scrolling, freezing and resuming, 2-14

Seek Error, 5-4

Select Error, 5-6

Serial device (see also I/O device), A-6

Serial port, D-2

Serial printer setup, 1-14

Serial Printers, 1-8

Serial transmission, D-2

SET command, 2-13, 2-19, 5-5, 5-6

SETDEF command, 3-5

SETUP program, 1-9, 1-15, 3-4, 4-17, D-2, D-6

SHIFT Key, B-10

Software
 additional, 4-9
 defined, B-1, C-4
 general specifications, A-4
 types, B-1

Source diskette, 3-7

Special Symbol Keys, B-11

STARTUP.PIL file, 4-14

Storage capacity, C-1

SUBMIT command, 3-5

SYS attribute, 2-13

- SYSGEN program, 3-9
- SYSLDR program, 4-5
- SYSLDR.COM file, 3-10
- SYSLDR3.COM file, 3-10
- System tracks, 3-10

- Telephone line, A-6, C-3
- Teletext format, 3-7
- Temporary data storage (see also RAM), B-3
- Terminal Setup, 1-8
- Terminals, C-4
 - adding new, 4-16
 - communication specifications, 1-9
 - compatibility with MD-11, 1-1
 - general requirements, A-5
 - installing, 1-5
 - levels, 3-8, 4-17
 - recommended, A-5
 - setting up, 1-8
- The Backfield, 2-8
- Track 0, 4-5
- Transferring data, 5-2
- Troubleshooting, 1-12, 1-14
- Turnkey systems, 3-6
- TUTORIAL.PIL file, 4-14
- TYPE command, 2-13
- Typing and printing simultaneously, 4-7

- Unable to Remap, 5-4
- USER command, 2-18
- User numbers, B-2
 - and file names, 4-1
 - association with application programs, 4-19
 - changing current, 2-18
 - examining directories, 2-5
 - in CP/M prompt, 4-2
 - programs in user 0, 3-1
 - reason for, 2-4
- User, defined, C-4
- Utility Menu
 - See Co-Pilot

Valid drive addresses, 5-6
VERIFILE program, 3-11, 4-4
View or Print a File, 2-13
Virtual drives, 3-7, 4-3

Warm boot, 5-5, C-4
WELCOME program, 2-7
Word processing program, C-1
Write protect, 5-2, B-7
 notch, 5-2

XON/XOFF handshaking, 1-16, D-5

Z80A CPU, B-3