

**DJ/DMA Floppy Disk Controller  
Technical Manual  
Revision 1**

**April 1982**

**MORROW DESIGNS** 

# DJ/DMA Floppy Disk Controller

## Technical Manual

Revision 1

### Table of Contents

1. INTRODUCTION.....	1
2. PROGRAMMING SPECIFICATIONS.....	3
2.1. The Channel Concept.....	3
2.2. The Start Channel Command.....	4
2.3. The Channel Command Address.....	4
2.4. Command Structure.....	5
2.5. DJDMA Controller Commands.....	5
2.6. Controller Command Specifications.....	6
2.6.1. SET DMA ADDRESS.....	6
2.6.2. READ SECTOR.....	7
2.6.3. WRITE SECTOR.....	9
2.6.4. SENSE DRIVE STATUS .....	9
2.6.5. SET INTERRUPT REQUEST.....	12
2.6.6. SET ERROR RETRY COUNT.....	13
2.6.7. SET LOGICAL DRIVE.....	13
2.6.8. SET HEAD UNLOAD/DRIVE DESELECT TIMEOUT.....	14
2.6.9. READ TRACK.....	14
2.6.10. WRITE TRACK.....	15
2.6.11. OUTPUT TO SERIAL PORT.....	16
2.6.12. SERIAL INPUT ENABLE/DISABLE.....	16
2.6.13. CONTROLLER HALT.....	17
2.6.14. BRANCH IN CHANNEL.....	17
2.6.15. SET CHANNEL ADDRESS.....	17
2.6.16. SET TRACK SIZE.....	18
2.6.17. READ CONTROLLER MEMORY .....	18
2.6.18. WRITE CONTROLLER MEMORY.....	19
2.6.19. EXECUTE CONTROLLER ROUTINE.....	19
2.7. Command Summary.....	20
2.8. Status Codes.....	20
3. IEEE 696 (S-100) BUS CONSIDERATIONS.....	21
4. INTERRUPTS.....	21
5. I/O CONNECTORS.....	22
6. JUMPED SETTINGS.....	22
6.1. EPROM Replacement.....	22
6.2. Bootstrap Program.....	23

Table of Contents, Cont.

7. BOOTSTRAP LOAD.....	23
8. BOOTING THE DJDMA.....	24
9. FORMATTING DISKETTES.....	24
Parts List.....	P-1
Subject Index.....	I-1
Software Listing.....	L-1
Component Layout/Schematic.....	S-1

List of Tables

2-1. Status Byte Codes.....	8
2-2. STATUS BYTE 1: Drive Characteristic Byte.....	10
2-3. STATUS BYTE 2: Sector Length Code - 0, 1, 2, or 3.....	10
2-4. STATUS BYTE 3: Drive Status/Characteristic Byte.....	11
2-5. Supported Commands.....	20
2-6. Unsupported Commands.....	20
2-7. Status Code Summary.....	20
7-1. 19-Byte Handshake Routine.....	23

## 1. INTRODUCTION

The Disk Jockey/Direct Memory Access (DJDMA) Floppy Disk Controller is a single board S-100 subsystem. It communicates with both 8 inch and 5 1/4 inch floppy disk drives. Up to eight drives may be connected to the controller - with the limitation that no more than four of each type can be accommodated.

Special programmable bipolar LSI logic makes it possible to read and write media with almost any format, be it hard or soft sectored. Presently, the controller supports soft-sectored IBM compatible 8 inch media and hard-sectored North Star compatible 5 1/4 inch media. In the spring of 1982, IBM and Radio Shack 5 1/4 inch soft-sectored media will also be supported. Existing controllers in the field can be upgraded by replacing two of the ICs on the unit. This is done at moderate cost to the user.

The controller has its own Z-80 4MHz microprocessor which is used to supervise data transfers between the disk drive and the system memory without intervention of the main CPU. This relieves the main CPU of time consuming processes which include head positioning, rotational delays, and the usual byte-by-byte transfer of data from the diskette to main memory. As a result, transfers are faster and more efficient. Moreover, the main CPU has more time for data processing, and thus, supports more users and/or tasks.

The main advantage of the DJDMA controller over almost all the others is its "glitch free" direct memory access channel. This advanced channel concept allows the controller to communicate with S-100 memory by "stealing" bus cycles from the main CPU. This idea of an intelligent I/O channel was first implemented by IBM on their famous 370 mainframes. Now for the first time, this powerful concept has been implemented on the S100 bus.

The channel has the full 24-bits of memory addressing as described in the proposed IEEE standard for the S-100 bus. Also, a great deal of care has been taken in the design of the interface circuitry so it conforms in every detail to this new standard and still allows the controller to work well with existing systems designed before the standardization effort was started.

The controller is a temporary bus master, meaning that it has the same access to memory as the CPU whenever it has control. It also features priority logic which allows it to contend with up to sixteen other "temporary" masters that may also want to "steal" bus cycles from the main CPU, or the "permanent" master.

The controller acts as a temporary master (TMA). A temporary master may take control of the bus to perform a DMA operation. This is possible because both the TMA and the CPU drive control lines. The CPU, as permanent master, monitors signals from the TMA. When the TMA wants control, it first asserts a HOLD/ signal to the CPU. Assuming the TMA has priority, the CPU acknowledges

this signal upon completion of the present bus cycle by returning a processor hold acknowledge (pHLDA) signal. Upon receipt of this signal, the TMA enables its control line and asserts a control disable (CDSB) signal, disabling the CPU's control line. The TMA then disables the CPU's data-out, address and status lines using DODSB/, ADSB/ and SDSB/ signals. At that point the TMA has complete control to perform its DMA operation.

To return control to the CPU, the TMA first disables its own data-out, address and status lines, then re-enables the CPU's control lines, and simultaneously, its data-out, address and status lines. The TMA then releases its control line and makes false the HOLD/ signal, thus returning full control to the CPU.

So far, the process has been described as if only one temporary master wanted control of the bus. There can be up to 16 temporary masters on the bus. When there is more than one temporary master, they use the four DMA lines to decide who gets to assert HOLD/. Any device requesting the bus places its TMA priority level on the bus, and circuitry on the device decides if it has the highest priority. The device with the highest priority (0F hex is highest) asserts HOLD/. It removes its priority from the DMA lines when it receives pHLDA from the permanent master.

The features associated with the intelligent channel on the controller make it exceptionally desirable in multi-tasking and multi-user applications. In fact, many were tailored to enhance the performance of Morrow Designs new, powerful DECISION I multi-processing IEEE 696/S-100 machine. The DJDMA is an integral part of this advanced microcomputer system which incorporates many of the concepts originally introduced by IBM in their famous 370 series mainframes.

The DJDMA can boot itself up on the bus and even has a primitive serial port which is intended for diagnostic purposes or possibly even integrating the controller into a larger S-100 system that has I/O that the boot disk is not aware of. **Under no circumstances** can it be used as a general purpose serial port to the system, however, since it is inactive during disk activity.

All in all, there is nothing on the market in the way of an S-100 bus floppy disk controller that comes anywhere near the performance and versatility of the DJDMA. For that matter, we here at Morrow Designs know of no other floppy disk controller on any bus that can match the DJDMA in price, power, performance, and flexibility.

Good luck with this product. One of the purposes of this document is to detail how the DJDMA controller can improve the speed and performance of your system. If we've missed anything, please let us know.

## 2. PROGRAMMING SPECIFICATIONS

### 2.1. The Channel Concept

The IBM 370 mainframe was the first computer system to make use of the channel concept. In the traditional setting, an I/O controller, even one with direct memory access ability, was normally sent commands one at a time. Status was then reported through I/O ports after a command had completed.

One of the things a Direct Memory Access Controller does (and should do well) is communicate with main memory. Having realized this, someone very clever at IBM reasoned that if a controller could communicate with memory all that easily, why shouldn't it pick up its commands from memory as well? For that matter, why not have it lay down its status information in the CPU's main memory also?

Once the idea of picking up one command from memory is accepted, it is only a small step to think about placing strings of commands in memory and having the controller begin treating memory in the same way as the CPU does itself! That is, memory should be used for both instructions and data.

There is one detail missing in the above discussion. How is the controller to be started and stopped? A CPU starts running when power is turned on and continues (in theory) forever. But then there is the situation of a device whose primary job it is to transfer information to and from main memory and a mass storage device of some kind; it should remain idle until the CPU tells it otherwise.

A possible solution to the problem above is to have the device sample a memory location for a start command. At power-up, however, solid state memory does not have a predictable pattern. A start command could be present before it was actually issued by the CPU. The only foolproof way to issue a start command is through an I/O port. But doesn't that put us right back where we started? Actually, no.

It takes very little I/O circuitry to issue a simple pulse which can serve as a start command. It is also a small price to pay in cost and circuit board real estate for the flexibility and efficiency that is obtained.

Stop commands are much easier. Simply build an instruction into the controller's command set that forces it back to the idle state it was in just prior to the initial start pulse issued by the CPU.

Obviously, a channel type of controller needs some kind of on-board intelligence. At the time that IBM first built this kind of device, it was expensive both in terms of dollars and in circuit board real estate to implement this intelligence. Today

## Programming Specifications

however, the situation is quite different. Microprocessors are inexpensive and take only a modest amount of space on a circuit board.

In theory, the only limitation to the power and flexibility of a channel driven controller is the size of the memory local to the resident microprocessor. Since memory is getting denser and cheaper, it would seem that time will favor the channel approach to I/O controllers.

### 2.2. The Start Channel Command

Just as in the general case discussed above, there is a single primitive I/O port on the DJDMA. It resides at location EF (hex) unless a custom unit has been ordered with a special I/O address. This port's only purpose is to send start pulses to the DJDMA controller. **Any output instruction to port EF (hex) starts the DJDMA.** It doesn't matter what value is sent nor does it matter what kind of device sends the data. **Any time any output reference is made to this port by the main CPU permanent master, or even by a temporary master, the DJDMA begins fetching and executing commands.** Where these commands come from and how they work is taken up below.

### 2.3. The Channel Command Address

When the DJDMA first powers up or is reset, there is a three-byte pointer initialized in its local memory. This pointer determines where the controller picks up its first command when a start pulse is issued via I/O port EF (hex).

There are actually two of these three-byte values the DJDMA maintains. The first points to where it should start its command sequence. The second points to where it should get its next command in the event that the current one is not a halt command. The user needs to be aware of both of these pointers as he sets up command sequences for the controller to execute.

The second pointer has the same function as the program counter of the main CPU: it always points to the next command that the controller will execute. The first pointer is similar to the value forced into the program counter (PC) of the main CPU when a reset signal is issued. In most cases, a reset signal forces a 0 into the PC. The processor commences to fetch instructions at this value.

The same is true for the DJDMA, except that the value is not zero. Also, unlike the CPU, this initial location can be changed by a sending the proper command to the controller. **The initial location that the DJDMA controller begins fetching commands from is 50 (hex).** The command that alters this starting location is described in the next section.

## 2.4. Command Structure

Commands to the DJDMA controller are at least two bytes long. The first byte is always the command code. Parameter lists follow the command byte (if needed) and the command status byte (if needed) comes at the end of the command string. The length of a command string varies with the command. Unless a branch in channel command is issued, commands must be arranged in memory one after the other with no gaps between the end of one command and the beginning of another. Sequences of commands must be terminated with either a controller halt command or a branch in channel command. If a sequence ends with a branch in channel command, another sequence of commands must be present at the location specified in the address parameter list of the branch in channel command.

## 2.5. DJDMA Controller Commands

The Disk Jockey DMA controller recognizes the following commands:

- SET DMA ADDRESS
- READ A SECTOR
- WRITE A SECTOR
- SENSE DRIVE STATUS
- SET INTERRUPT REQUEST
- SET ERROR RETRY COUNT
- READ TRACK
- WRITE TRACK
- OUTPUT SERIAL PORT
- SERIAL INPUT ENABLE/DISABLE
- CONTROLLER HALT
- BRANCH IN CHANNEL
- SET CHANNEL ADDRESS
- SET TRACK SIZE
- SET DRIVE DESELECT/HEAD UNLOAD TIMEOUT
- SET LOGICAL DRIVE
- READ CONTROLLER MEMORY
- WRITE CONTROLLER MEMORY
- BRANCH TO CONTROLLER ROUTINE

The last three commands require great care to use. They are used to format diskettes and will be used to support media formats which are not yet implemented. Improper use of any of the last three commands could produce unpredictable results and may cause the loss of information on write-enabled diskettes in drives connected to the controller. It could also cause the controller to be inoperative until a bus reset is performed.



Morrow Designs will have a separate document (at extra cost) that describes the firmware on the DJDMA controller. This information should be available at the end of first quarter 1982 or early second quarter. Thus, users with special applications will have a way to extend the command structure of the DJDMA controller. However, extended commands will not be supported by Morrow Designs and we cannot stress too strongly that efforts in this direction will require a great deal time and expertise to complete and debug.

## 2.6. Controller Command Specifications

Specifications for each of the controller commands are described in the following sections. In many instances, examples are given to fully illustrate use of the command.

### 2.6.1. SET DMA ADDRESS

Command code:	23 (hex)
Command length:	4 bytes
Command parameter list length:	3 bytes
Command status list length:	0 bytes

The command length is four bytes. The first byte is the command code: 23 (hex). The next three bytes specify a 24-bit address in main memory where data is written to or read from during subsequent disk transfers. This field must be arranged so that the least significant byte of the address directly follows the command byte. The byte of next highest significance follows. The highest order byte of the address is last. The last byte specifies an extended page as defined in the proposed IEEE standard for the S-100 bus and allows memory addressing to be extended to 16 million bytes.

In systems that do not support this new extended addressing, the value of this high order byte is not important. However, it must be present - whether it is used or not. Other commands which have three byte address fields in their parameter list require the same byte significance order as described above. The firmware that processes commands on the DJDMA expects all address fields to be three bytes long - even if only two of the three have effect on the address bus of the system.

The following example is a command that sets the DMA address of the controller to location 80 (hex) - the default disk data buffer of the popular CP/M operating system:

23 80 00 00 (hex).

2.6.2. READ SECTOR

Command code:	20 (hex)
Command length:	5 bytes
Command parameter list length:	3 bytes
Command status list length:	1 byte

The three-byte parameter field following the command code consists of

1. track
2. side/sector
3. drive

in that order. The side select is encoded in the high order bit of the sector field and merged together to form the second byte in the parameter list. The third byte determines which of eight possible drives are read. If the system has been booted up from a 5 1/4 inch drive, drives 0 through 3 specify this; drives 4 through 7 specify 8 inch drives. If the system has been booted from an 8 inch drive, the numbering is reversed with the first four being 8 inch drives and the last four being 5 1/4 inch. The following example is a command that reads data from sector 3 of track 5 on side 1 of drive 0:

20 05 83 00 00

The last zero is provided so that the controller can fill in the status of the transfer after it has completed the read. Here is a second example that reads sector 2 from track 6 on side 0 of drive 1:

20 06 02 01 00

Again, the last byte is for status reporting and it must be there.

The length of the sector (and consequently a valid range of sector values) depends on what size drive is being addressed and how the media has been formatted. In the media currently supported, the following sector values and data field lengths are relevant:

5 1/4" hard sectored single density:	0 - 9	256 bytes
5 1/4" hard sectored double density:	0 - 9	512 bytes
8" soft sectored single density:	1 - 26	128 bytes
8" soft sectored double density:	1 - 26	256 bytes
8" soft sectored double density:	1 - 15	512 bytes
8" soft sectored double density:	1 - 8	1024 bytes

The numbers in the above list are all decimal. The sector size, density, and valid range of values for the sector

## Command Specifications

number are all determined automatically by the controller. The controller can inform the system of these parameters by executing the SENSE DRIVE STATUS command which is taken up below. These details are presented here because it is necessary to know how much space the controller will use when data is read from the disk into main memory. Also, an error occurs if incorrect values are specified for the sector, track, or drive.

All 8 inch drives presently have 77 tracks numbered 0 through 76. This is not the case with 5 1/4 inch drives. Some have 35 tracks numbered 0 through 34, others have 40 tracks numbered 0 through 39, and finally, the new double track density 5 1/4 inch drives have 80 tracks numbered 0 through 79. The default value for 5 1/4 inch drives on the DJDMA is 40. However, this value can be changed by executing a SET TRACK SIZE command which is discussed below.

The last byte in the read sector command is called the status byte. This byte should be filled with some value other than what the controller might use when it reports status after the command is completed. A 0 is ideal since the controller does not use this value. For that matter, it does not use FF either. Either of these values are handy since they can be tested easily. By testing the status byte, the system can determine when a read command (among others) has completed. Below is a list of status byte codes along with their meanings. All values are in hex.

**Table 2-1. Status Byte Codes**

40 -	normal completion - no errors
80 -	improper command code
81 -	illegal disk drive value
82 -	drive not ready
83 -	illegal track value
84 -	unreadable media
85 -	improper sector header - no sync byte
86 -	CRC error in sector header read
87 -	seek error
88-8D -	compare error in sector header scan
8E -	CRC error in data field
8F -	illegal sector value for current media
90 -	media is write protected (writing only)
91 -	lost data - DMA channel did not respond
92 -	lost command - channel did not respond

The above list is complete and applies to any command that reports status in its last byte. Not all codes apply to all commands. For example, 90 (hex) never appears as the status reported by the READ SECTOR command.

## 2.6.3. WRITE SECTOR

Command code:	21 (hex)
Command length:	5 bytes
Command parameter list length:	3 bytes
Command status list length:	1 byte

The three-byte parameter field and the status byte have the same properties as those in the read sector command. All the items discussed in the read sector command apply to the write sector command with the exception that the write sector command can report a media write protect error (90 hex).

## 2.6.4. SENSE DRIVE STATUS

Command code:	22 (hex)
Command length:	6 bytes
Command parameter list length:	1 byte
Command status list length:	4 bytes

The single byte in the parameter list specifies a drive. Legal values range from 0 to 7. The last byte of the status list has codes which were listed above in the READ SECTOR command. The first three bytes of status are peculiar to a specific drive and are detailed below. However, **unless the last status byte contains a 40 (hex), the preceding three bytes do not accurately reflect the condition and characteristics of the drive whose status was supposed to be sensed.**

If any value other than 40 (hex) is present, nothing can be learned from the first three status bytes. When the final byte contains a 40 (hex), the first three describe characteristics and status concerning the drive specified in the parameter byte of the command.

**Table 2-2. STATUS BYTE 1: Drive Characteristic Byte**

Each bit in this byte describes a different characteristic of the drive specified in the parameter field of the command.

- Bit 0 - Information internal to the controller.
- Bit 1 - If the media is hard-sectored, this bit is a 1. When the media in the drive is soft-sectored this bit will be a 0.
- Bit 2 - If the drive is 5 1/4 inch, this bit is a 1. If the drive is 8 inch, the bit is a 0.
- Bit 3 - If the drive has a DC motor with an ON/OFF switch, this bit is a 1. If there is no ON/OFF switch, or if the drive motor is AC, this bit is a 0.
- Bit 4 - If the media in the drive is double density, this bit is a 1. It is 0 only if the media is single density.
- Bit 5 - If this bit is a 1 there is no "drive ready" signal supplied by the drive. For drives with no "ready" signal, the DJDMA firmware tests for the presence of sector/index holes. If the drive has an active "ready" signal, this bit is a 0.
- Bit 6 - If there is no "head load" command line to the drive, the controller assumes that the head(s) are always loaded against the media and this bit is a 1. If there is a "head load" command line to the drive, this bit is a 0.
- Bit 7 - If the head(s) are currently loaded against the media, this bit is a 1. If the head(s) are not loaded, this bit is a 0.

**Table 2-3. STATUS BYTE 2: Sector Length Code - 0, 1, 2, or 3**

The 0 indicates a sector length of 128 bytes, 1 stands for a length of 256 bytes, 2 means that the length is 512 bytes, and 3 indicates that the sector is 1024 bytes long. These are all decimal numbers.

**Table 2-4. STATUS BYTE 3: Drive Status/Characteristic Byte**

There is an input port on the controller which can examine status signals transmitted directly from the selected drive.

The third status byte is a direct image of this port.

- Bit 0 - Used internally by the controller and is of no meaning to the system.
- Bit 1 - Current status of the serial input line from an RS-232 device which may be attached to connector P3, the serial port of the controller.
- Bit 2 - This bit indicates that a double-sided 8 inch drive is currently selected and that double-sided media is present in the drive. This line is not driven by 5 1/4 inch drives; thus, an indirect means must be employed to determine if a 5 1/4 inch drive is double-sided and has double-sided media in it.
- Bit 3 - Currently not used.
- Bit 4 - This is the index/sector hole indicator. If this bit is a 1, the drive has sensed the presence of either an index hole or a sector hole.
- Bit 5 - If this bit is a 1, the head(s) of the drive are at Track 0. If the head(s) are positioned over some other track, this bit is a 0.
- Bit 6 - This bit is a 1 if the media in the drive is write protected. A zero indicates that the media is not write protected and disk write commands do not produce "write protect" errors.
- Bit 7 - This is the drive ready bit. Most 5 1/4 inch drives have no signal on this line; thus, it is not a good "drive ready" indicator in this case.

All 8 inch drives produce a "ready" signal at this bit. If the current drive is an 8 inch and this bit is 1, the drive is "ready" to accept read, write, or step commands. If it is a 0, the 8 inch drive is not "ready" and will not respond to commands from the controller.

## Command Specifications

### 2.6.5. SET INTERRUPT REQUEST

Command code:	24 (hex)
Command length:	2 bytes
Command parameter list length:	0 bytes
Command status list length:	1 byte

This command generates an interrupt to the system bus. There is a bus driver on the DJDMA circuit board whose output terminates at a jumper pad near the lower edge of the board (the exact location is described later in the manual). This jumper pad is arranged so that the driver can be connected to the main interrupt line of the system bus (PINT\*) or any one of the eight vectored interrupt lines (VI0\*, VI1\*, ... VI7\*).

The controller is shipped from the factory with the driver uncommitted. If the DJDMA is to generate interrupts to the system, this driver must be connected to one of the nine interrupt lines. If the driver is not connected, the INTERRUPT REQUEST command causes the controller to pause until another start pulse is issued by the system. However, once an INTERRUPT REQUEST command is executed, the controller is put into a special state where the board responds differently to the start pulse than it usually does.

Normally a start pulse causes the controller to begin fetching commands at the location specified by the most recent channel command word address. When the DJDMA executes an INTERRUPT REQUEST, it activates the interrupt bus driver on the circuit board. It then pauses with this bus driver still active.

Upon receipt of the next start pulse, the controller turns off the bus driver generating the interrupt and fetches the command **which immediately follows the interrupt request command**. The controller thus treats the first start pulse issued after the interrupt request command has completed as an **INTERRUPT ACKNOWLEDGE handshake signal**. This is the only circumstance in which a start pulse to the controller does not cause the command pointer to be reset.

The system can test the status byte following the command code to determine when the command has completed. When the command completes, it fills the status byte with a 40 (hex). When the interrupt request bus driver is not connected, an interrupt request command causes the controller to pause until the next start pulse is received, at which time it resumes executing commands where it left off.

2.6.6. SET ERROR RETRY COUNT

Command Code:	28 (hex)
Command length:	2 bytes
Command parameter list length:	1 byte
Command status list length:	0 bytes

This command specifies how many times a sector is read in the event that a CRC error occurs in the data field. At least one read always takes place, so the smallest value that should appear in the parameter byte is a 1. This value can be as high as 255 (decimal). The default value is 10 (decimal).

This command's main purpose is to ensure that the value can be made smaller for diagnostic purposes. It is also useful when a diskette becomes worn and data recovery becomes more difficult. In this case, the value is made larger.

2.6.7. SET LOGICAL DRIVE

Command code:	2E (hex)
Command length:	3 bytes
Command parameter list length:	1 byte
Command status list length:	1 byte

This command allows the user to change the logical numbering assigned to the 8 inch and 5 1/4 inch drives. The default values assigned the the 8 inch drives are 0 through 3, while the 5 1/4 inch drives are assigned values 4 through 7.

If a 4 appears in the parameter list of this command, the 5 1/4 inch drives are assigned drive values 0 through 3, while the 8 inch drives have their values changed to 4 through 7. A 0 in the parameter field reverses these values to the original default values. There is no status byte associated with this command and bit-2 in the parameter field is the only part of the byte examined by the command.

The status byte reported by the command reflects the logical value of the first physical 8 inch drive prior to the execution of the SET LOGICAL DRIVE command. If the status is 40 (hex), the previous logical value of the first physical 8 inch drive was 0. If the status is 44 (hex), the old value was 4.

The logical values assigned to the drives are also affected by performing a bootstrap operation which is discussed later.



## Command Specifications

### 2.6.8. SET HEAD UNLOAD/DRIVE DESELECT TIMEOUT

Command Code:	2F (hex)
Command length:	2 bytes
Command parameter list length:	1 byte
Command status list length:	0 bytes

In order to conserve power and maximize diskette life, during periods of disk inactivity the controller unloads the drive head(s) and deselects the drive after a certain number of revolutions of the diskette. Normally, the controller waits sixteen revolutions before it deselects a drive. This command allows the user to change this situation. The value in the parameter list determines how many revolutions occur after no disk activity before the head(s) are unloaded and the drive is deselected. A disk transfer operation requires more time if the drive is not selected and so, under certain conditions, it may be desirable to extend the time before a drive is deselected after a transfer occurs. This command makes it possible to affect this situation. The value in the parameter field should be between 1 and 255 (decimal). However, when the heads are loaded for extended periods of time with the motor running, diskette media life is shortened considerably.

### 2.6.9 READ TRACK

Command code:	29 (hex)
Command length:	8 bytes
Command parameter list length:	6 bytes
Command status list length:	1 byte

This command reads an entire track into main memory starting at the value specified by the most recent SET DMA ADDRESS command. The transfer begins with the first full sector encountered by the controller. Thus, the buffer may not fill from the beginning.

As an example, suppose that the diskette had eight 1024 byte sectors and the first full sector of data encountered was Sector 6. In this case the last 3072 bytes of the buffer would be filled with Sectors 6, 7, and 8. The DJDMA memory pointer would then be reset to the start of the track buffer and Sectors 1 through 5 would be transferred.

The first three bytes of the parameter list specify

1. track
2. side
3. drive

in that order. The side bit must appear in the most significant bit of the byte. Thus, the second byte in the parameter list is either 0 or 80 (hex). The last three bytes of the parameter list form a memory pointer to a sector table.

There must be an entry in this table for each sector on the track.

As an example, if the diskette in the selected drive had 512 byte sectors, there would be fifteen entries and the table length would also be fifteen. This table should be initialized with 0s, 80s (hex), or FFs (hex).

As a sector of the track is read, the controller fills the byte of the table corresponding to the sector with status information concerning that particular sector (assuming the initial entry was 0). Thus, the system can determine error information individually, sector by sector.

If the controller encounters an FF (hex) entry in the sector table, it skips that sector which corresponds to the entry.

If a whole section of the table has FFs, the sectors corresponding to this section are not read.

If the controller encounters an entry in the table of 80 (hex), the READ TRACK command terminates at that point. An example should illustrate these ideas.

Suppose side 1 of track 23 (decimal) is to be read into a track buffer starting at location 00E000 (hex) from drive 2 and that a set DMA address command with this value has already been executed. Suppose also that there are 1024 byte sectors on the diskette and that the sector table is to immediately precede the track buffer in memory. The command to read the track would then appear as follows:

29 17 80 02 F8 DF 00 00

The sector table address of 00DFF8 (hex) has a value of eight less than 00E000 (hex) since there are eight sectors on the track of the diskette. The last byte (indicated with a value of 00) is the overall status byte for the command. The status codes are the same as the READ SECTOR COMMAND where they are listed.

#### 2.6.10. WRITE TRACK

Command Code:	2A (hex)
Command length:	8 bytes
Command parameter list length:	6 bytes
Command status list length:	1 byte

The write track command is similar to the READ TRACK command. The six bytes of the parameter list are exactly the same and even the sector table entries work the same. Normally, the table has 0s as entries. Sectors that are not to be written (or rewritten) are marked with FFs (hex) while an 80 (hex) causes the command to terminate.

## Command Specifications

As with the read track command, the starting address of the track buffer is initialized with a SET DMA ADDRESS command.

### 2.6.11. OUTPUT TO SERIAL PORT

Command code:	2B (hex)
Command length:	3 bytes
Command parameter list length:	1 byte
Command status list length:	1 byte

This command communicates with the output portion of the bit serial port on the DJDMA. The parameter byte is filled with the ASCII value that is to be transmitted to the RS-232 device connected to the port. The status byte should be initialized to either 0 or FF (hex). The command fills the status byte with a 40 (hex) when all eight data bits and two stop bits have been transmitted.

The speed of this serial port is 9600 baud and cannot be changed. Also, it is vital that the system refrain from sending new start pulses to the controller until this command has completed. Otherwise, transmission of the serial stream is aborted before any or all of the bits have been sent.

The main purpose of the port in this subsystem is to allow a user to boot-up in a system where I/O devices are not defined on the boot diskette. This port is not adequate as a system consul port and will cause the controller to run less efficiently while the port is active (there is no disk activity while the serial port is engaged in data transmission). Input serial data can also be easily lost if the controller is supervising data transfer to or from a disk drive.

The input side of this serial port does not work the same as the output and is discussed in the next command.

### 2.6.12. SERIAL INPUT ENABLE/DISABLE

Command Code:	2C (hex)
Command length:	2 bytes
Command parameter list length:	1 byte
Command status list length:	0 bytes

This command enables or disables input from the bit serial RS-232 port on the controller. Serial input operates in a slightly different manner than serial output. If the input side of the port is enabled, characters received by the port are deposited at location 00003E (hex).

After loading a new character at this location, the controller writes 40 (hex) at location 00003F (hex). This second location serves as a status flag for serial input and should be reset to some other value after reading the character.

In the enable/disable command, the value of the parameter byte determines whether the port is to be enabled or disabled. A 0 in this byte instructs the controller to turn off the port, while a 1 forces the DJDMA to enable input. At boot-up, input is enabled, but if there is no terminal connected to the board, it is automatically disabled.

#### 2.6.13. CONTROLLER HALT

Command code:	25 (hex)
Command length:	2 bytes
Command parameter list length:	0 bytes
Command status list length:	1 byte

This command is used to halt the DJDMA controller. There are no parameters. The status byte should be initialized to 0 or FF (hex). The controller fills this byte with a 40 (hex) when the command completes. As mentioned previously, this command resets the command pointer. Hence, the next start pulse causes the controller to begin fetching commands from the channel command word address which has an initial value of 000050 (hex). This value can be changed with a command that is described below.

#### 2.6.14. BRANCH IN CHANNEL

Command code:	26 (hex)
Command length:	4 bytes
Command parameter list length:	3 bytes
Command status list length:	0 bytes

The three parameter bytes specify a branch address for the controller. This address is the location from where the controller fetches its next command. The address bytes are arranged so that the low order byte immediately follows the command code, the middle order byte is next and the high order byte is last. There is no status code and immediately after execution, the controller picks up the next command from the branch address.

#### 2.6.15. SET CHANNEL ADDRESS

Command code:	27 (hex)
Command length:	4 bytes
Command parameter list length:	3 bytes
Command status list length:	0 bytes

The three parameter bytes of this command specify a memory address. After this command has executed, start pulses from the system cause the controller to fetch its first instruction at this address. The order of the bytes is the same as the branch in channel command. There is no status byte associated with this command.

## Command Specifications

### 2.6.16. SET TRACK SIZE

Command Code:	2D (hex)
Command length:	4 bytes
Command parameter list length:	2 bytes
Command status list length:	1 byte

This command allows the system to change the number of tracks that the controller assumes are on a disk drive. The first byte in the parameter list describes a drive and should have values between 0 and 7. Other values cause the command to return an error and not change the track value of any drive.

The second byte must contain a hex number which is **one larger** than the largest numerical track on the diskette. For 35 track drives, this value is 35 since the track numbering starts at zero. For the same reason, the value is 40 for 40 track drives, 77 for 77 track drives, and 80 for 80 track drives. (All the numbers used in this paragraph are decimal. They must be changed to hexadecimal when incorporated into the command string.)

It is possible to damage a drive if seeks are performed to tracks which extend beyond the boundaries of the seek mechanism. The controller has no way to determine if a particular value is improper for a given drive. **The user must exercise care in executing this command and Morrow Designs takes no responsibility for damage that occurs through its misuse.**

### 2.6.17. READ CONTROLLER MEMORY

Command Code:	A0 (hex)
Command length:	8 bytes
Command parameter list length:	7 bytes
Command status list length:	0 bytes

The first three bytes of the parameter list specify a main memory address with bytes in ascending order (just like the other commands that required a three-byte address field.)

The next two bytes specify a count which can have values anywhere between 0 and FFFF (hex). The last two bytes specify an address in the memory of the on-board Z-80A microprocessor. This command transfers local memory to main memory which allows the main CPU to read the controller's memory. It is not advisable to read locations 4001 (hex), 8001 (hex), A000 (hex), etc., since this type of reference causes the controller to hang waiting for data from a drive when none is selected. The only way to reliably recover from this fault is to issue a reset to the system. **Morrow Designs does not recommend use this command and does not support applications that make use of this command or the two that follow.** This command reports no status.

2.6.18. WRITE CONTROLLER MEMORY

Command Code:	A1 (hex)
Command length:	8 bytes
Command parameter list length:	7 bytes
Command status list length:	0 bytes

The first three bytes of the parameter list specify a main memory address in ascending order (just like the other commands that required a three-byte address field.)

The next two specify a count that can range between 0 and FFFF (hex).

The last two bytes specify an address in the memory space of the on-board Z-80A microprocessor. This command transfers data from main memory to the memory of the controller. There are only 1024 bytes of RAM on the controller board. This RAM starts at location 1000 (hex). The only locations safe to write in are between 1030 and 127F (hex). Writing in other locations produces unpredictable results and can lead to loss of data on diskettes which are not write protected and are inserted in drives connected to the controller. **Morrow Designs does not support the use of this command. This command is used in diskette format programs (included in this manual) but we strongly recommend that it not be used for other purposes).** There is no status byte associated with this command.

2.6.19. EXECUTE CONTROLLER ROUTINE

Command Code:	A2 (hex)
Command length:	3+ bytes
Command parameter list length:	2 bytes
Command status list length:	0+ bytes

The two bytes in the parameter list specify an address in the memory space of the on-board Z-80A microprocessor. This command forces the on-board processor to branch to and begin executing instructions at this address. As with the previous command, it is extremely dangerous and should not be used by anyone except those well versed with the inner workings of the controller. The status list length is given as 0+ bytes because the length and type of status varies depending on the nature of the routine at the specified address. **As with the previous two commands, Morrow Designs does not support use of this command.**

## Command Summary

### 2.7. Command Summary

The following tables summarize commands that are both supported and unsupported by the DJDMA.

**Table 2-5. Supported Commands**

- Set DMA (low, med, high)
- Read Sector (track, side/sector, drive, status)
- Write Sector (track, side/sector, drive, status)
- Sense Status (dstat1, dstat2, dstat3, status)
- Set Interrupt Request (status)
- Set Error Retry Count (count)
- Set Logical Drive (drive, type)
- Set Head Unload/Drive Deselect Timeout (revolution count)
- Read Track (track, side, drive, low, med, high, status)
- Write Track (track, side, drive, low, med, high, status)
- Serial Port Output (ASCII byte)
- Serial Input Enable/disable (control byte)
- Controller Halt (status)
- Branch in Channel (low, med, high)
- Set Channel Address (low, med, high)
- Set Track Size (drive, hitrack)

**Table 2-6. Unsupported Commands**

- Read CMemory (tlow, tmed, thigh, lcnt, hcnt, slow, shigh)
- Write CMemory (slow, smed, shigh, lcnt, hcnt, tlow, thigh)
- Execute Controller Routine (low, high, ..., ...)

### 2.8. Status Codes

The following table summarizes the DJDMA status codes.

**Table 2-7. Status Code Summary**

STATUS CODE	DESCRIPTION
40 .....	Normal completion - no error encountered
80 .....	Improper Command Code
81 .....	Improper Disk Drive Value
82 .....	Disk Drive Not Ready
83 .....	Improper Track Value
84 .....	Unreadable Media
85 .....	Improper Sector Header - No Sync Byte(s)
86 .....	CRC Error in Sector Header Scan
87 .....	Seek Error
88 - 8D .....	Compare Error in Sector Header Scan
8E .....	CRC Error in Data Field
8F .....	Improper Sector Value
90 .....	Media Write Protected
91 .....	Lost Data - DMA Channel did not respond
92 .....	Lost Command - Channel did not respond

### 3. IEEE 696 (S-100) BUS CONSIDERATIONS

The DJDMA controller has been designed to meet the IEEE/696 proposed standard for the S-100 bus and will operate properly in any S-100 mainframe which meets this proposed standard and can accommodate temporary bus masters. In fact, the DJDMA runs in most existing S-100 systems in operation today. However, we cannot guarantee that the controller will operate in a system unless it meets **all the specifications contained in the IEEE/696 document.**

In transferring data from a floppy disk directly into main memory, the DJDMA assumes that the permanent master in the system will respond to bus requests by the controller fast enough so that data will not be lost. If an 8 inch double density drive is connected to the controller, a byte of data is read or written every 16 microseconds.

The transfer rate for single density 8 inch drives and double density 5 1/4 inch drives is a byte every 32 microseconds.

Single density 5 1/4 inch drives have a transfer rate of one byte every 64 microseconds. If some device, such as a front panel, holds the READY line of the bus down for extended periods during disk transfers, data is lost and the controller cannot function properly.

Morrow Designs assumes that the user has made the proper determination concerning the ability of his system to respond to bus requests from the DJDMA so that data is not lost during disk transfers. **Morrow Designs is not responsible for operation of the controller in systems that cannot respond to bus requests at least as fast as those detailed above for the various types of floppy disk drives.**

### 4. INTERRUPTS

At the lower left area of the DJDMA circuit board, just above the edge connector fingers, is a jumper area designed so users can connect the board's interrupt request bus driver to one of the nine interrupt request lines: VI0\*, VI1\*, VI2\*, VI3\*, VI4\*, VI5\*, VI6\*, VI7\*, or PINT\* (See the component layout for an illustration of this area).

If the system does not use interrupts, there is no need to connect J3 to any of these lines. If J3 is not jumpered, it appears to the system that the controller has entered a pause state when it executes an interrupt request command. All activity stops (just as it does after a halt command). When the next start pulse is sent to the controller, it picks up its next instruction from the memory location immediately following the status byte of the interrupt request command (this is not the same as a halt command).



The DJDMA is shipped from the factory without any jumpering between J3 and the interrupt request lines. If the controller is to generate interrupt requests, the user must determine which of the nine possible connections is appropriate for his system. The DECISION I user reference manuals contain information about how the DJDMA communicates with the interrupt controller on the MULT-I/O and WUNDERBUSS I/O boards, and should serve as an example of how interrupts from the DJDMA could work in other systems.

## 5. I/O CONNECTORS

Refer to the component layout drawing included in this manual for a more complete understanding of the discussion in this section.

There are three I/O connectors at the top of the DJDMA circuit board: P1, P2, and P3.

P3 is at the top left-hand side of the board and is the connector for the bit serial RS-232 port. It has three pins, numbered 1 through 3 from left to right. Pin-1 is the RS-232 ground signal, pin-2 is the input and pin-3 is the RS-232 output signal.

To the right of P3 is P2. P2 has 34 pins and is used to connect 5 1/4 inch drives to the controller. The pins are arranged in two rows - the odd numbered pins being just above the even numbered ones. The pins are numbered 1 through 33, odd from right to left, and 2 through 34, even from right to left. All the odd numbered pins are connected to ground while the even numbered pins carry information to and from 5 1/4 inch floppy disk drives.

P1 is the right-most connector and has 50 pins. This connector is used to connect 8 inch drives to the controller and has pins arranged in two rows, the same as P2. The upper pins are odd and are numbered 1 through 49, right to left. The lower pins are even and are numbered 2 to 50, right to left. As before, all odd pins are grounds while even pins carry signals between the controller and 8 inch drives.

## 6. JUMPERED SETTINGS

Refer to the component layout drawing included in this manual for a more complete understanding of the discussion in this section.

### 6.1. EPROM Replacement

The jumpered setting at J1 (located in the upper right hand corner of the board) is factory set B to C for a 2732 EPROM. It may be jumpered A to B, effectively replacing it with a 2716 EPROM. But please note that the **factory setting must be maintained** for proper system operation. The optional setting reduces the address space available and is only to be used in special, limited applications.

## 6.2. Bootstrap Program

J2 (located in the lower mid-section of the board) is jumpered B to C for conditional bootstrap operation. This mode is used for the Decision I and controllers are shipped from the factory with a jumper between these two pins.

J2 is jumpered A to B for non-bootstrap mode in systems which cannot allow a temporary master to hog the bus and intend to boot the DJDMA controller by external means.

## 7. BOOTSTRAP LOAD

The DJDMA performs an automatic bootstrap load at reset or power-on if J2 is jumpered B to C and a shunt jumper is placed between pins 1 and 2 of P3, or if a terminal is connected to P3. In either case, the controller halts the main CPU by taking control of the bus and reads the first 38 (hex) locations in main memory into its own local memory. Next it loads 0s into these first 38 (hex) bytes and places a short, 19 byte (decimal) handshake routine between 000038 and 00004A (hex). The bus is then released. When the main CPU executes the first part of the handshake routine, the controller restores the first 38 (hex) locations of main memory to its original state. Next, 80 (hex) bytes are loaded between 000080 and 0000FF (hex) from the first sector on Track 0 of the disk. Finally, the controller writes a control byte to the handshake routine which causes the main CPU to branch to location 000080 (hex). A listing of the 19-byte handshake routine is given below.

Table 7-1. 19-Byte Handshake Routine

000038	21 4A 00	START:	LXI	H, 4A
00003B	36 00		MVI	M, 0
00003D	7E	LOOP:	MOV	A, M
00003E	B7		ORA	A
00003F	CA 3D 00		JZ	LOOP
000042	FE 40		CPI	40H
000044	C2 3D 00		JNZ	LOOP
000047	C3 80 00		JMP	80H
00004A	FF		DB	0FFH

The controller will boot from either the first drive connected to the 8 inch port or the first drive connected to the 5 1/4 inch port. The decision as to which port to choose is determined by testing for a "drive ready" signal. The 8 inch port is tested first. The controller will alternately continue to test for "drive ready" indefinitely to allow the user time to insert a diskette. This is evidenced by the indicator lights on the disk drives. They will alternately blink as the controller checks for the ready signal.

### 8. BOOTING THE DJDMA

The following is the proper procedure for booting the DJDMA:

1. Open the door of any drive the DJDMA could boot from.
2. Insert a bootstrap diskette in the boot drive WITHOUT closing the driver door.
3. Depress the RESET switch.
4. While the RESET switch is depressed, close the drive door.
5. Release the RESET switch.

It is possible that the above procedure will have to be repeated twice depending on the value of location 0.

If a shunt jumper across pins 2 and 3 of P3 is not in place or if a terminal is not connected to P3, the controller powers itself up in normal "cycle steal" mode and waits for commands from the system.

### 9. FORMATTING DISKETTES

There are no firmware commands on the DJDMA to format diskettes for two reasons: Formatting is a dangerous operation. If a diskette is in a drive with valuable information written on it, an accidental format command could destroy this data. The controller is also capable of formatting a wide variety of diskettes and the EPROM is not large enough to accommodate both the command processor code and all of the desirable format routines.

For these reasons, the format routines are loaded from main memory using the WRITE CONTROLLER MEMORY command and executed using the EXECUTE CONTROLLER ROUTINE command. A listing of two format programs for IBM soft-sectored 8 inch diskettes and North Star hard-sectored 5 1/4 inch diskettes appears as an appendix to this manual. These programs are also available on diskettes for a modest cost for those who wish to avoid using controller commands not supported in the field.

When a CP/M operating system is shipped with either a lone DJDMA controller or a disk system which includes a DJDMA controller, there are built-in commands on the system diskette which will format both types of diskettes.

## Parts List

Amount	Function	Description
1	PC board	DJDMA
5	Diode	1N914
1	Transistor	2N3904
6	Transistor	2N3906
2	Regulator	+5 volts
1	Regulator	+12 volts
1	Regulator	-12 volts
1	Resistor	1K Ohm 1/4W 5%
2	Resistor	1 Meg Ohm 1/4W 5%
1	Resistor	12K Ohm 1/4W 5%
1	Resistor	1.2K Ohm 1/4W 5%
1	Resistor	1.5K Ohm 1/4W 5%
1	Resistor	180 Ohm 1/4W 5%
2	Resistor	27K Ohm 1/4W 5%
4	Resistor	330 Ohm 1/4W 5%
11	Resistor	3.3K Ohm 1/4W 5%
1	Resistor	390 Ohm 1/4W 5%
3	Resistor	4.7K Ohm 1/4W 5%
1	Resistor	47K Ohm 1/4W 5%
1	Resistor	2.0K Ohm 1/4W 1%
1	Resistor	20.0K Ohm 1/4W 1%
1	Resistor	28.0K Ohm 1/4W 1%
1	SIP	180K 1/8W 5% (10-pin)
1	SIP	3.3K 1/8W 5% (8-pin)
1	Inductor	4.7uh
1	Capacitor	.001mf ceramic disk
13	Capacitor	.1uf mono cap
1	Capacitor	.01 mylar cap
1	Capacitor	33pf silver/mica
2	Capacitor	47pf silver/mica
2	Capacitor	100pf silver/mica
1	Capacitor	1200pf silver/mica
1	Capacitor	620 pf silver/mica
8	Capacitor	luf dip. tant.
1	Crystal	4 MHz
1	PCB Header	SIN RT> NHD 3
1	PCB Header	DIN RT> HD 34
1	PCB Header	DIN RT> HD 50
2	Slide Jumpers	
2	Screws	632 X 5/16 Pan Phil

Parts List

Parts List, Cont.

2	Hex Nuts	632
2	Heat Sinks	Low Profile 3 Fin
2	Heat Sinks	Slimline 5 prong
1	IC Socket	Low Profile (8-pin)
13	IC Sockets	Low Profile (14-pin)
12	IC Sockets	Low Profile (16-pin)
2	IC Sockets	Low Profile (18-pin)
15	IC Sockets	Low Profile (20-pin)
1	IC Socket	Low Profile (24-pin)
1	IC Socket	Low Profile (28-pin)
1	IC Socket	Low Profile (40-pin)
1	IC	1458
2	IC	2114-3 RAM
1	IC	7404
1	IC	7406
1	IC	74LS02
1	IC	74LS04
1	IC	74LS08
1	IC	74LS10
2	IC	74LS138
1	IC	74LS139
1	IC	74LS153
3	IC	74LS221
1	IC	74LS244
2	IC	74LS273
1	IC	74LS279
1	IC	74LS299
4	IC	74LS373
4	IC	74LS374
1	IC	74LS38
1	IC	74LS393
3	IC	74LS74
1	IC	74LS75
1	IC	81LS95
1	IC	81LS96
1	IC	PAL
1	IC	FPLA
5	IC	PROM

Subject Index**B**

BRANCH IN CHANNEL, 17  
Board compatibility, 1

**C**

CONTROLLER HALT, 17  
CP/M data buffer, 6  
Command Pointer reset, 17  
Command parameter lists, 5  
Command status byte, 5  
Controller  
    DMA channel, 1  
    microprocessor, 1  
    supervision of data transfer, 1  
Cycle steal mode, 24

**D**

DJDMA self boot capability, 2  
DMA communication with main memory, 3  
Dangers of formatting diskettes, 24  
Data recovery, 13  
Data transfer, 21  
Drive values, 13

**E**

EXECUTE CONTROLLER ROUTINE, 19  
Extended addressing, 6

**I**

IEEE standards and board compatibilty, 1  
Intelligent I/O channel, 1  
Interrupt request lines, 12

**J**

Jumpering interrupt request lines, 22

**L**

Listing of DJDMA Controller Commands, 5  
Listing of status byte codes, 8  
Listing of valid sector values, 7

## Subject Index

### M

#### Master

permanent, 1, 4  
temporary, 1, 4

### O

OUTPUT TO SERIAL PORT, 16

### P

Permanent master, 1, 4  
Port enable and terminal connection, 17  
Power-up or reset pointer, 4  
Primitive I/O port - DJDMA, 4  
Program Counter, 4

### R

READ CONTROLLER MEMORY, 18  
READ SECTOR, 7  
READ TRACK, 14

### S

Sector transfer sample, 14  
SENSE DRIVE STATUS, 9  
SERIAL INPUT ENABLE/DISABLE, 16  
SET CHANNEL ADDRESS, 17  
SET DMA ADDRESS, 6  
SET ERROR RETRY COUNT, 13  
SET HEAD UNLOAD/DRIVE DESELECT TIMEOUT, 14  
SET INTERRUPT REQUEST, 12  
SET LOGICAL DRIVE, 13  
SET TRACK SIZE, 18  
Serial port communication, 16  
Start command, 3  
Status flag for serial input, 16  
Stealing bus cycles, 1  
Stop command, 3

### T

Temporary master, 1, 4  
Track numbering, 8

U

Undefined I/O devices, 16

W

WRITE CONTROLLER MEMORY, 19

WRITE SECTOR, 9

WRITE TRACK, 15

Z

Z-80A - memory transfer, 19



**SOFTWARE LISTING**

```

0000' 31 059E'      START: LD    SP,ECODE+30H      ;initialize the stack pointer
0003' 21 1030'      LD    HL,1030H      ;initialize command address
0006' 22 0161'      LD    (DOTCMD+1),HL
0009' 21 113A'      LD    HL,SDADVT
000C' 22 0167'      LD    (ATCMD+1),HL
000F' 21 016F'      LD    HL,SMESG
0012' CD 011E'      CALL  OUTM          ;start of program message
0015' CD 012A'      CALL  INPUT        ;send the message
0018' D2 0024'      JP    NC,DATAOK   ;get response to drive number
001B' 21 01BA'      LD    HL,RMESSG   ;test for valid input
001E' CD 011E'      CALL  OUTM          ;invalid input message
0021' C3 0000'      JP    START        ;send the message
0024' 32 045D'      LD    (SINGLE+1),A   ;go back to start of program
0027' 21 01ED'      LD    HL,DMESG     ;store the drive number in code
002A' CD 011E'      CALL  OUTM          ;type of density message
002D' CD 012A'      CALL  INPUT        ;send the message
0030' DA 001B'      JP    C,DEXIT     ;wait for response
0033' E6 01        AND    1            ;test for improper input
0035' 32 032A'      LD    (DENSITY),A  ;density encoded in bit 0
0038' CA 0065'      JP    Z,SIDE      ;save for later use
003B' 21 0225'      LD    HL,LMESG    ;skip sector size if single density
003E' CD 011E'      CALL  OUTM          ;sector length message
0041' CD 012A'      CALL  INPUT        ;send the message
0044' DA 001B'      JP    C,DEXIT     ;wait for input
0047' FE 03        CP    3            ;test for improper input
0049' CA 001B'      JP    Z,DEXIT     ;further test for improper input
004C' 16 00        LD    D,0          ;error exit
004E' 5F          LD    E,A          ;form offset into sector table
004F' 3C          INC    A          ;adjust for sector length code
0050' 32 03C5'      LD    (DLCODE-DDFMT+DOUBLE),A ;store in format code
0053' 21 016C'      LD    HL,STABLE
0056' 19          ADD    HL,DE
0057' 7E          LD    A,M          ;fetch number of sectors
0058' 32 0407'      LD    (DLAST-DDFMT+DOUBLE),A ;store in format code
005B' 3E 20        LD    A,20H       ;sector length code is 80,100, or 0
005D' 87          DCNST: ADD   A,A
005E' 1D          DEC    E          ;decrement the sector type
005F' F2 005D'      JP    P,DCNST     ;test for cycle done
0062' 32 03EF'      LD    (DSIZE-DDFMT+DOUBLE),A ;store 1/4 length in format code
0065' 21 0265'      LD    HL,HMESSG   ;double sided media message
0068' CD 011E'      CALL  OUTM          ;send the message
006B' CD 012A'      CALL  INPUT        ;wait for input
006E' DA 001B'      JP    C,DEXIT     ;test for improper input
0071' E6 01        AND    1            ;discard all but bit 0
0073' 32 041C'      LD    (DDBIT-DDFMT+DOUBLE),A ;store in format code double density
0076' 32 0532'      LD    (DSBIT-SDFMT+SINGLE),A ;store in format code single density
0079' 21 0151'      LD    HL,LSDCMD   ;load single density code command
007C' 06 0A        LD    B,0AH       ;command length
007E' CD 00FB'      CALL  LCMD        ;load the code
0081' 21 0160'      LD    HL,DOTCMD   ;format track 0 command
0084' 06 06        LD    B,6         ;command length
0086' CD 00FB'      CALL  LCMD        ;execute the command
0089' CA 00AB'      JP    Z,PROCED    ;zero => no error
008C' 21 029A'      LD    HL,RMESSG   ;drive not ready message
008F' FE B2       CP    B2H         ;drive not ready error code
0091' CA 0097'      JP    Z,$+6       ;test for drive not ready
0094' 21 02D6'      LD    HL,WMESG    ;drive must be write protected

```

```

0097'   CD 011E'           CALL   OUTM           ;send the message
009A'   CD 012A'           CALL   INPUT          ;wait for input
009D'   DA 001B'           JP      C,DEXIT        ;test for improper input
00A0'   E6 01             AND    1              ;discard all but bit 0
00A2'   CA 0000'           JP      Z,START        ;zero => start the program over
00A5'   C3 0079'           JP      LOADC          ;go back and do the command over
00A8'   21 0327'           PROCED: LD   HL,CRLF          ;carriage return and line feed
00AB'   CD 011E'           CALL   OUTM           ;output the string
00AE'   21 1050'           LD     HL,SDRDY        ;adjusted execution address of format
00B1'   3A 032A'           LD     A,(DENSTY)
00B4'   B7                OR     A              ;test for double density
00B5'   CA 00C9'           JP      Z,CONTUE       ;make no adjustments for single density
00B8'   21 0147'           LD     HL,LDDCMD       ;load double density format command
00BB'   06 0A             LD     B,0AH          ;command length
00BD'   CD 00FB'           CALL   LCMD            ;load the code into controller
00C0'   21 1159'           LD     HL,DDADVT       ;advance track execute address
00C3'   22 0167'           LD     (ATCMD+1),HL   ;update the command execute address
00C6'   21 1030'           LD     HL,1030H        ;format execute address
00C9'   22 0161'           CONTUE: LD (DOTCMD+1),HL ;update track format execute address
00CC'   3E 2A             LD     A,"*"          ;send a star for a track done
00CE'   CD 0114'           CALL   OUTPUT          ;advance track command
00D1'   21 0166'           LD     HL,ATCMD        ;command length
00D4'   06 06             LD     B,6            ;load the command and execute
00D6'   CD 00FB'           CALL   LCMD            ;last track value (77 decimal)
00D9'   FE 4D             CP     4DH            ;zero => formatting done
00DB'   C2 00E7'           JP      NZ,FMTRCK      ;send final message
00DE'   21 0312'           ENDFMT: LD HL,FMESG    ;go format another disk
00E1'   CD 011E'           CALL   OUTM           ;format a track command
00E4'   C3 0000'           JP      START          ;command length
00E7'   21 0160'           FMTRCK: LD HL,DOTCMD   ;load and execute the command
00EA'   06 06             LD     B,6            ;loop back for more tracks
00EC'   CD 00FB'           CALL   LCMD            ;drive has become not ready
00EF'   CA 00CC'           JP      Z,CONTUE+3
00F2'   21 029A'           LD     HL,RMESG       ;stop the formatting
00F5'   CD 011E'           CALL   OUTM           ;start of command sequence
00F8'   C3 00DE'           JP      ENDFMT        ;get command data
                                ;load into command area
                                ;advance the pointers
00FB'   11 0050'           LCMD:  LD   DE,50H     ;start the controller
00FE'   7E                LD   A,M              ;pointer for status byte of halt cmd
00FF'   12                LD   (DE),A           ;test for command string done
0100'   23                INC  HL               ;status byte for execute command
0101'   13                INC  DE               ;test for no error
0102'   05                DEC  B                ;start of command sequence
0103'   C2 00FE'           JP      NZ,LCMD+3     ;get command data
                                ;load into command area
                                ;advance the pointers
0106'   D3 EF           ECMD:  OUT  (0EFH),A   ;start the controller
0108'   1B                DEC  DE               ;pointer for status byte of halt cmd
0109'   1A                LD   A,(DE)          ;test for command string done
010A'   B7                OR   A                ;status byte for execute command
010B'   CA 0109'           JP      Z,ECMD+3     ;test for no error
010E'   3A 0053'           LD   A,(53H)         ;start of command sequence
0111'   FE 40             CP   40H              ;get command data
0113'   C9                RET                   ;load into command area
                                ;advance the pointers
0114'   21 015C'           OUTPUT: LD HL,SOCMD+1 ;data byte of serial output command
0117'   06 05             LD   B,5              ;serial output command string length
0119'   77                LD   M,A              ;store the data
011A'   2B                HL  HL                ;back up to pointer
011B'   C3 00FB'           JP      LCMD          ;load the command and execute

```

```

011E' 7E          OUTM: LD      A,M          ;get current byte of message
011F' B7          OR      A          ;test for end of message
0120' C8          RET     Z          ;return at end of message
0121' E5          PUSH   HL         ;save the character pointer
0122' CD 0114'    CALL  OUTPUT        ;output the character
0125' E1          POP    HL         ;recover the character pointer
0126' 23          INC    HL         ;advance the character pointer
0127' C3 011E'    JP     OUTM       ;go get the next character

012A' 21 003F    INPUT: LD      HL,3FH        ;serial input status byte
012D' 3E 40      LD      A,40H        ;test value for status
012F' 96          SUB    M          ;test for character ready
0130' C2 012D'   JP     NZ,INPUT+3      ;zero => new character ready
0133' 77          LD      M,A          ;zero out the status byte
0134' 2B          DEC    HL         ;back up pointer to the character
0135' 7E          LD      A,M          ;pickup the character
0136' F5          PUSH   AF          ;save the data
0137' CD 0114'   CALL  OUTPUT        ;echo the data
013A' F1          POP    AF          ;turn it into ASCII
013B' E6 7F      AND    7FH        ;test for smaller than zero
013D' FE 30      CP     30H        ;test for larger than three
013F' D8          RET     C          ;change ASCII to binary
0140' FE 34      CP     34H
0142' 3F          CCF
0143' D8          RET     C
0144' E6 03      AND    3
0146' C9          RET
          PAGE

```

```

0147'  A1          LDDCMD: DB    0A1H          ;write controller memory command
0148'  032B'      DW    DOUBLE          ;main memory address pointer
014A'  00          DB    0              ;
014B'  0131      DW    SINGLE-DOUBLE   ;byte count
014D'  1030      DW    1030H          ;controller memory address pointer
014F'  25        DB    25H            ;controller halt command
0150'  00        DB    0              ;halt command status byte

0151'  A1          LSDCMD: DB    0A1H          ;
0152'  045C'      DW    SINGLE          ;
0154'  00          DB    0              ;
0155'  0112      DW    ECODE-SINGLE     ;
0157'  1030      DW    1030H          ;
0159'  25        DB    25H            ;
015A'  00        DB    0              ;

015B'  2B        SOCMD: DB    2BH          ;output character to controller cmd
015C'  00        DB    0              ;output data
015D'  00        DB    0              ;output character command status
015E'  25        DB    25H            ;controller halt command
015F'  00        DB    0              ;halt command status byte

0160'  A2          DOTCMD: DB    0A2H          ;execute controller routine command
0161'  1030      DW    1030H          ;format a track address
0163'  00        DB    0              ;execute command status
0164'  25        DB    25H            ;halt command
0165'  00        DB    0              ;status byte

0166'  A2          ATCMD:  DB    0A2H          ;
0167'  113A      DW    SDADVT          ;advance the track value address
0169'  00        DB    0              ;
016A'  25        DB    25H            ;
016B'  00        DB    0              ;

016C'  1B        STABLE: DB    1BH          ;26 sectors per track (256 bytes)
016D'  10        DB    10H           ;15 sectors per track (512 bytes)
016E'  09        DB    9             ;8 sectors per track (1024 bytes)

```

PAGE

```

016F' 0D0A          SMESG: DW      CRLFS
0171' 49 42 4D 20          DB      "IBM Comptable 8 inch Format Program"
0175' 43 6F 6D 70
0179' 61 74 61 62
017D' 6C 65 20 38
0181' 20 69 6E 63
0185' 68 20 46 6F
0189' 72 6D 61 74
018D' 20 50 72 6F
0191' 67 72 61 6D
0195' 0D0A          DW      CRLFS
0197' 53 65 6C 65          DB      "Select a Drive ( 0, 1, 2, or 3 ): "
019B' 63 74 20 61
019F' 20 44 72 69
01A3' 76 65 20 28
01A7' 20 30 2C 20
01AB' 31 2C 20 32
01AF' 2C 20 6F 72
01B3' 20 33 20 29
01B7' 3A 20
01B9' 00          DB      0
01BA' 0D0A          BMESG: DW      CRLFS
01BC' 49 6D 70 72          DB      "Improper input - returning to start of program"
01C0' 6F 70 65 72
01C4' 20 69 6E 70
01C8' 75 74 20 2D
01CC' 20 72 65 74
01D0' 75 72 6E 69
01D4' 6E 67 20 74
01D8' 6F 20 73 74
01DC' 61 72 74 20
01E0' 6F 66 20 70
01E4' 72 6F 67 72
01E8' 61 6D
01EA' 0D0A          DW      CRLFS
01EC' 00          DB      0
01ED' 0D0A          DMESG: DW      CRLFS
01EF' 53 65 6C 65          DB      "Select double density ( 1 ) or single density ( 0 ): "
01F3' 63 74 20 64
01F7' 6F 75 62 6C
01FB' 65 20 64 65
01FF' 6E 73 69 74
0203' 79 20 28 20
0207' 31 20 29 20
020B' 6F 72 20 73
020F' 69 6E 67 6C
0213' 65 20 64 65
0217' 6E 73 69 74
021B' 79 20 28 20
021F' 30 20 29 3A
0223' 20
0224' 00          DB      0
0225' 0D0A          LMESG: DW      CRLFS
0227' 53 65 6C 65          DB      "Select the byte length of a sector ( 0=256, 1=512, 2=1024 ): "
022B' 63 74 20 74
022F' 68 65 20 62
0233' 79 74 65 20

```

```

0237' 6C 65 6E 67
023B' 74 68 20 6F
023F' 66 20 61 20
0243' 73 65 63 74
0247' 6F 72 20 28
024B' 20 30 3D 32
024F' 35 36 2C 20
0253' 31 3D 35 31
0257' 32 2C 20 32
025B' 3D 31 30 32
025F' 34 20 29 3A
0263' 20
0264' 00
0265' 0D0A
0267' 53 65 6C 65
026B' 63 74 20 73
026F' 69 6E 67 6C
0273' 65 20 28 20
0277' 30 20 29 20
027B' 6F 72 20 64
027F' 6F 75 62 6C
0283' 65 20 28 20
0287' 31 20 29 20
028B' 73 69 64 65
028F' 64 20 6D 65
0293' 64 69 61 20
0297' 3A 20
0299' 00
029A' 0D0A
029C' 44 72 69 76
02A0' 65 20 6E 6F
02A4' 74 20 72 65
02A8' 61 64 79 20
02AC' 2D 20 72 65
02B0' 73 74 61 72
02B4' 74 20 70 72
02B8' 6F 67 72 61
02BC' 6D 3F 20 28
02C0' 20 30 20 29
02C4' 20 6F 72 20
02C8' 63 79 63 6C
02CC' 65 20 28 20
02D0' 31 20 29 3A
02D4' 20
02D5' 00
02D6' 0D0A
02DB' 57 72 69 74
02DC' 65 20 70 72
02E0' 6F 74 65 63
02E4' 74 65 64 20
02E8' 2D 20 72 65
02EC' 73 74 61 72
02F0' 74 20 70 72
02F4' 6F 67 72 61
02F8' 6D 3F 20 28
02FC' 20 30 20 29
0300' 20 6F 72 20
0304' 63 79 63 6C
0308' 65 20 28 20

```

```

          DB      0
HMESG:   DW      CRLFS
          DB      "Select single ( 0 ) or double ( 1 ) sided media : "

```

```

          DB      0
RMESG:   DW      CRLFS
          DB      "Drive not ready - restart program? ( 0 ) or cycle ( 1 ) : "

```

```

          DB      0
WMESG:   DW      CRLFS
          DB      "Write protected - restart program? ( 0 ) or cycle ( 1 ) : "

```

030C' 31 20 29 3A  
0310' 20  
0311' 00  
0312' 0D0A  
0314' 46 6F 72 6D  
0318' 61 74 74 69  
031C' 6E 67 20 66  
0320' 69 6E 69 73  
0324' 68 65 64  
0327' 0D0A  
0329' 00  
032A' 00

FMESG: DB 0  
          DW CRLFS  
          DB "Formatting finished"  
  
CRLF: DW CRLFS  
      DB 0  
DENSITY: DB 0  
          PAGE



```

032B'
1030 21 4003
1033 CB 7E
1035 3E 82
1037 C8
1038 CB 76
103A 3E 90
103C C0
103D DD 36 0B 00
1041 3A 10C4
1044 FD BE 01
1047 F5
1048 C4 00A3
104B 21 4001
104E 11 4007
1051 F1
1052 FE 2B
1054 3E 04
1056 38 02
1058 3E 14
105A 32 1081
105D 9F
105E F6 FE
1060 FD A6 02
1063 F6 02
1065 FD 77 02
1068 F6 0C
106A 32 4005
106D 06 50
106F 3A 4003
1072 E6 10
1074 20 F9
1076 3A 4003
1079 E6 10
107B 28 F9
107D 3E 90
107F 12
1080 3E 00
1081
1082 32 4006
1085 36 4E
1087 10 FC
1089 06 0C
108B 36 00
108D 10 FC
108F 3E 80
1091 12
1092 36 52
1094 36 24
1096 36 52
1098 36 24
109A 36 52
109C 3E 90
109E 12
109F 36 24
10A1 36 FC

DOUBLE EQU $
.PHASE 1030H
DDFMT: LD HL,STATUS
BIT 7,M ;check that the drive is ready
NREXIT: LD A,82H ;drive not ready error code
RET Z ;error exit
BIT 6,M ;test for write protected
LD A,90H ;write protected error code
RET NZ ;error exit
LD (IX+0BH),0 ;reset index counter
LD A,(DTRCK) ;get the new track value
CP (IY+1) ;compare with current track
PUSH AF ;save the track
CALL NZ,SEEK ;move the head(s) if needed
LD HL,DISKD ;pointer to disk shift register
LD DE,CONTRL ;pointer to control port
POP AF ;recover the tack
CP 2BH ;compare with track 43
LD A,4 ;no write precompensation
JR C,LOADPC ;carry => track is less than 43
LD A,14H ;write precompensation bit set
LOADPC: LD (PRECMP),A ;setup the write precompensation byte
SBC A,A ;push carry bit throughout accumulator
OR 0FEH ;low current bit now set
AND (IY+2) ;merge with drive pattern
OR 2 ;select side 0
LD (IY+2),A ;restore drive pattern
OR 0CH ;turn off step command
LD (4005H),A ;update the drive register
LD B,50H ;preamble length
DDLBL1: LD A,(STATUS)
AND INDEX ;look for index pulse
JR NZ,DDLBL1 ;wait for no index pulse present
DDLBL2: LD A,(STATUS)
AND INDEX
JR Z,DDLBL2 ;wait for leading edge of new index pulse
LD A,90H ;control byte - normal write/no CRC
LD (DE),A ;initialize control port
LD A,0
PRECMP EQU $-1 ;write precompensation & controller start
LD (4006H),A ;start the controller
DDLBL3: LD M,4EH ;write the preamble
DJNZ DDLBL3 ;zero preamble length
DDLBL4: LD M,0
DJNZ DDLBL4 ;write the zero preamble
LD A,80H ;control byte for 16 bit write
LD (DE),A ;change mode
LD M,52H ;first half of C2
LD M,24H ;second half of C2
LD M,52H ;another C2
LD M,24H
LD M,52H ;the third C2
LD A,90H ;control byte 8 bit write
LD (DE),A ;change mode
LD M,24H ;finish the sync bytes
LD M,0FCH ;index mark
    
```

```

10A3 06 32          LD      B,32H          ;postamble length
10A5 36 4E          DDLBL5: LD      M,4EH
10A7 10 FC          DJNZ   DDLBL5          ;write the postamble

10A9 06 0C          DMLOOP: LD     B,0CH          ;zero preamble length
10AB 36 00          DDLBL6: LD     M,0
10AD 10 FC          DJNZ   DDLBL6          ;write the preamble
10AF 3E 81          LD      A,81H          ;16 bit write mode w/CRC
10B1 12             LD      (DE),A        ;change mode
10B2 36 44          LD      M,44H          ;first half of A1
10B4 36 89          LD      M,89H          ;second half of A1
10B6 36 44          LD      M,44H          ;second A1
10B8 36 89          LD      M,89H
10BA 36 44          LD      M,44H          ;third A1
10BC 3E 91          LD      A,91H          ;8 bit write mode w/CRC
10BE 12             LD      (DE),A        ;change mode
10BF 36 89          LD      M,89H          ;finish sync bytes
10C1 36 FE          LD      M,0FEH         ;sector header ID byte
10C3 36 00          LD      M,0            ;write the track number
10C4
10C5 36 00          DTRCK  EQU     $-1
10C6                LD      M,0            ;write the side
10C7                DSIDE  EQU     $-1
10C8                LD      M,1            ;write the sector number
10C9 36 01          DSECT  EQU     $-1
10CA                LD      M,1            ;sector length code
10CB 3E A1          DLCODE EQU     $-1
10CD 12             LD      A,0A1H         ;mode to write CRC bytes
10CE 77             LD      (DE),A        ;change mode
10CF 77             LD      M,A
10D0 3E 90          LD      A,90H          ;write the CRC bytes
10D2 12             LD      (DE),A        ;reset CRC generator
10D3 06 16          LD      B,16H          ;change mode
10D5 36 4E          DDLBL7: LD     M,4EH          ;4E postamble length
10D7 10 FC          DJNZ   DDLBL7          ;write the postamble
10D9 06 0C          LD      B,0CH          ;data field preamble
10DB 36 00          DDLBL8: LD     M,0
10DD 10 FC          DJNZ   DDLBL8          ;write the preamble
10DF 3E 81          LD      A,81H          ;16 bit write w/CRC
10E1 12             LD      (DE),A        ;change mode
10E2 36 44          LD      M,44H          ;first half of A1
10E4 36 89          LD      M,89H          ;second half of A1
10E6 36 44          LD      M,44H          ;second A1
10E8 36 89          LD      M,89H
10EA 36 44          LD      M,44H          ;third A1
10EC 3E 91          LD      A,91H          ;8 bit write w/CRC
10EE 12             LD      (DE),A        ;change mode
10EF 36 89          LD      M,89H          ;finish the 3 sync bytes
10F1 36 FB          LD      M,0FBH         ;data header ID byte
10F3 06 40          LD      B,40H          ;sector length divided by four
10F4                DSIZE  EQU     $-1
10F5 36 E5          DDLBL9: LD     M,0E5H         ;empty sector data byte
10F7 36 E5          LD      M,0E5H
10F9 36 E5          LD      M,0E5H
10FB 36 E5          LD      M,0E5H          ;write four fill bytes
10FD 10 F6          DJNZ   DDLBL9          ;test for data field write done
10FF 3E A1          LD      A,0A1H         ;CRC control byte
1101 12             LD      (DE),A        ;change mode
1102 77             LD      M,A            ;write the CRC bytes

```

```

1103      77          LD      M,A
1104      3E 90      LD      A,90H          ;turn off the CRC generator
1106      12          LD      (DE),A      ;change mode
1107      3A 10C8    LD      A,(DSECT)      ;get the sector number
110A      3C          INC      A
110B      FE 1B      CP      1BH          ;test for last sector +1
110C          DLAST EQU      $-1
110D      36 4E      LD      M,4EH          ;first byte of postamble
110F      20 02      JR      NZ,$+4      ;zero => all sectors written
1111      3E 01      LD      A,1
1113      32 10C8    LD      (DSECT),A      ;update the sector number
1116      06 35      LD      B,35H          ;postamble length less one
1118      36 4E      DDLBLA: LD      M,4EH
111A      10 FC      DJNZ    DDLBLA      ;write the postamble
111C      20 8B      JR      NZ,DMLOOP
111E      36 4E      LD      M,4EH          ;first fill byte
1120      06 00      LD      B,0          ;double sided bit test
1121          DDSBIT EQU      $-1
1122      3A 10C6    LD      A,(DSIDE)
1125      A8          XOR      B          ;conditionally switch the side byte
1126      32 10C6    LD      (DSIDE),A      ;update the side byte
1129      36 4E      LD      M,4EH          ;second fill byte
112B      06 4F      LD      B,4FH          ;preamble length less one
112D      08          EX      AF,AF'      ;save the double sided status
112E      36 4E      DLBLB: LD      M,4EH          ;write a fill byte
1130      3A 4003    LD      A,(STATUS)
1133      E6 10      AND      INDEX          ;wait for the index pulse
1135      28 F7      JR      Z,DLBLB
1137      08          EX      AF,AF'      ;recover the double sided status
1138      28 0F      JR      Z,DDLBLC      ;zero => track write is done
113A      FD 7E 02  LD      A,(IY+2)      ;drive pattern
113D      F6 0C      OR      0CH          ;turn off the step command
113F      E6 FD      AND      0FDH          ;change read/write heads
1141      32 4005    LD      (4005H),A      ;update the command register
1144      36 4E      LD      M,4EH          ;first preamble byte
1146      C3 1085    JP      DDLBL3      ;format the other side
1149      36 4E      DDLBLC: LD      M,4EH          ;trailing fill byte
114B      36 4E      LD      M,4EH          ;trailing fill byte
114D      36 4E      LD      M,4EH          ;trailing fill byte
114F      AF          XOR      A
1150      12          LD      (DE),A      ;turn off the write gate
1151      3E 06      LD      A,6
1153      32 4006    LD      (4006H),A      ;turn off the controller
1156      3E 40      LD      A,40H          ;status code
1158      C9          RET
1159      3A 10C4    DDADVT: LD      A,(DTRCK)      ;get the current track value
115C      3C          INC      A          ;increment
115D      32 10C4    LD      (DTRCK),A      ;restore the new value
1160      C9          RET          ;return with current track value
          .DEPHASE
          PAGE

```

```

045C'
1030 3E 00          SINGLE EQU $
1032 CD 00A6       .PHASE 1030H
1035 C0            SDFMT: LD A,0 ;second byte filled with proper drive number
1036 FD 7E 02     CALL SDRIVE ;select the new drive
1039 F6 0F        RET NZ ;return if wrong value
103B 32 4005     LD A,(IY+2) ;get the drive pattern
103E 21 0000     OR 0FH ;side 0 and no step command
1041 2B          LD (4005H),A ;update drive control register
1042 7C          LD HL,0 ;delay for the head load
1043 B5          SDWAIT: DEC HL
1044 20 FB        LD A,H
1046 DD 77 0B     OR L
1049 CD 00A0     JR NZ,SDWAIT
104C CB 6E        LD (IX+0BH),A ;reset the index counter
104E 28 05     SDTRK0: CALL HOME ;calibrate the head(s)
1050 21 4003     BIT 5,M ;test for track zero
1053 CB 7E        JR Z,SNREXT
1055 3E 02     SDRDY: LD HL,STATUS
1057 C8          BIT 7,M ;test for the drive ready
1058 CB 76        LD A,82H ;drive not ready code
105A 3E 90     SNREXT: LD Z ;error exit
105C C0          RET ;write protect bit
105D DD 36 0B 00  LD (IX+0BH),0 ;write protect error code
1061 3A 10B6     NZ ;reset the index counter
1064 FD BE 01     LD A,(STRCK) ;get the new track
1067 C4 00A3     CP (IY+1) ;compare with current track
106A 21 4001     CALL NZ,SEEK ;do track seek if necessary
106D 11 4007     LD HL,DISK ;controller data register
1070 06 28     LD DE,CONTRL ;control register
1072 3A 4003     LD B,28H ;preamble length
1075 E6 10     SDLBL1: LD A,(STATUS)
1077 20 F9     AND INDEX
1079 3A 4003     JR NZ,SDLBL1 ;wait for no index pulse
107C E6 10     SDLBL2: LD A,(STATUS)
107E 28 F9     AND INDEX
1080 3E 90     JR Z,SDLBL2 ;wait for leading edge of new index pulse
1082 12         LD A,90H ;clear the CRC register & turn on write gate
1083 3E 44     LD (DE),A ;change modes
1085 32 4006     LD A,44H ;single density & start bit
1088 36 FF     LD (4006H),A ;start the controller
108A 10 FC     SDLBL3: LD M,0FFH
108C 3E 80     DJNZ SDLBL3 ;write the preamble
108E 12         LD A,80H ;16 bit write mode
108F 06 0C     LD (DE),A ;change modes
1091 36 AA     LD B,0CH ;zero preamble length
1093 10 FC     SDLBL4: LD M,0AAH ;half a zero cell
1095 36 F7     DJNZ SDLBL4 ;write the zero preamble
1097 3E 90     LD M,0F7H ;first half of FC
1099 12         LD A,90H ;8 bit write mode
109A 36 7A     LD (DE),A ;change modes
109C 06 1A     LD M,7AH ;second half of FC
109E 36 FF     LD B,1AH ;postamble length
10A0 10 FC     SDLBL5: LD M,0FFH
10A2 3E 80     DJNZ SDLBL5 ;write the postamble
SMLOOP: LD A,80H ;16 bit write mode

```

```

10A4 12          LD      (DE),A          ;change modes
10A5 06 0C      LD      B,0CH          ;sector header preamble length
10A7 36 AA      SDLBL6: LD      M,0AAH        ;half a zero cell
10A9 10 FC      DJNZ   SDLBL6        ;write the preamble
10AB 3E 81      LD      A,81H          ;enable CRC & 16 bit write
10AD 12          LD      (DE),A          ;change modes
10AE 36 F5      LD      M,0F5H        ;first half of FE
10B0 3E 91      LD      A,91H          ;enable CRC & 8 bit write
10B2 12          LD      (DE),A          ;change modes
10B3 36 7E      LD      M,7EH          ;second half of FE
10B5 36 00      LD      M,0          ;write the track
10B6           STRCK  EQU      $-1
10B7 36 00      LD      M,0          ;write the side byte
10B8           SSIDE  EQU      $-1
10B9 36 01      LD      M,1          ;write the sector number
10BA           SSECT  EQU      $-1
10BB 36 00      LD      M,0          ;write the sector length code
10BD 3E A1      LD      A,0A1H
10BF 12          LD      (DE),A          ;change modes
10C0 77          LD      M,A
10C1 77          LD      M,A
10C2 3E 90      LD      A,90H          ;write the CRC bytes
10C4 12          LD      (DE),A          ;reset the CRC
10C5 06 0B      LD      B,0BH          ;change modes
10C7 36 FF      SDLBL7: LD      M,0FFH        ;sector header postamble length
10C9 10 FC      DJNZ   SDLBL7        ;write the postamble
10CB 3E 80      LD      A,80H          ;16 bit write mode
10CD 12          LD      (DE),A          ;change modes
10CE 06 0C      LD      B,0CH          ;data field preamble length
10D0 36 AA      SDLBL8: LD      M,0AAH        ;half a zero cell
10D2 10 FC      DJNZ   SDLBL8        ;write the preamble
10D4 3E 81      LD      A,81H          ;enable CRC & 16 bit write
10D6 12          LD      (DE),A          ;change modes
10D7 36 F5      LD      M,0F5H        ;first half of FB
10D9 3E 91      LD      A,91H          ;8 bit write
10DB 12          LD      (DE),A          ;change modes
10DC 36 6F      LD      M,6FH          ;second half of FB
10DE 06 B0      LD      B,80H          ;sector data field length
10E0 36 E5      SDLBL9: LD      M,0E5H        ;write the data field
10E2 10 FC      DJNZ   SDLBL9
10E4 3E A1      LD      A,0A1H
10E6 12          LD      (DE),A          ;change modes
10E7 77          LD      M,A
10E8 77          LD      M,A
10E9 3E 90      LD      A,90H          ;write the CRC bytes
10EB 12          LD      (DE),A          ;reset the CRC
10EC 3A 10BA    LD      A,(SSECT)        ;change modes
10EF 3C          LD      A,(SSECT)        ;get the current sector
10F0 FE 1B      INC      A          ;advance
10F2 36 FF      CP      1BH          ;compare with 27
10F4 20 02      LD      M,0FFH        ;first postamble byte
10F6 3E 01      JR      NZ,$+4        ;zero => all sectors written
10F8 32 10BA    LD      A,i          ;update the sector
10FB 06 1A      LD      (SSECT),A        ;postamble length less one
10FD 36 FF      SDLBLA: LD      M,0FFH
10FF 10 FC      DJNZ   SDLBLA        ;write the postamble
1101 20 9F      JR      NZ,SMLOOP      ;test for more sectors to format
1103 36 FF      LD      M,0FFH        ;first fill byte
1105 06 00      LD      B,0          ;side bit

```

```

1106          SDSBIT EQU    $-1
1107      3A 10B8      LD      A,(SSIDE)      ;get the current side
1108      A8           XOR      B              ;conditionally switch side bits
1109      32 10B8      LD      (SSIDE),A      ;update the side byte
110A      36 FF       LD      M,0FFH        ;write second fill byte
110B      06 19       LD      B,19H         ;preamble length less one
110C      08         EX      AF,AF'         ;save the double sided status
110D      36 FF       SDLBLEB: LD      M,0FFH ;write a fill byte
110E      3A 4003     LD      A,(STATUS)
110F      E6 10      AND      INDEX
1110      28 F7       JR      Z,SDLBLEB      ;wait for the index hole
1111      08         EX      AF,AF'         ;recover the double sided status
1112      28 0F       JR      Z,SDLBLC      ;zero => single sided
1113      FD 7E 02    LD      A,(IY+2)       ;get the drive pattern
1114      F6 0C       OR      0CH           ;turn off the step command
1115      E6 FD       AND      0FDH         ;turn on head one
1116      32 4005     LD      (4005H),A      ;update drive control register
1117      36 FF       LD      M,0FFH        ;write first preamble byte
1118      C3 10B8     JF      SDLBLEB3      ;go format the other side
1119      36 FF       SDLBLC: LD      M,0FFH ;trailing byte
111A      AF         XOR      A
111B      12         LD      (DE),A        ;turn off write gate
111C      3E 06      LD      A,6
111D      32 4006     LD      (4006H),A      ;turn off the controller
111E      3E 40      LD      A,40H         ;status code
111F      C9         RET
1120      3A 10B6     SDADVT: LD      A,(STRCK) ;get the current track
1121      3C         INC      A              ;advance track value
1122      32 10B6     LD      (STRCK),A      ;update the track value
1123      C9         RET                    ;return with track value
1124          .DEPHASE
056E'        ECODE EQU    $
            END

```

```

0000' 31 04A2'          START: LD      SP, ECODE+30H
0003' 21 1030'          LD      HL, 1030H
0006' 22 0177'          LD      (DOTCMD+1), HL
0009' 3E 20'            LD      A, 20H
000B' 32 0404'          LD      (DATA-NSFMT+FORMAT), A
000E' 32 0406'          LD      (CPDATA-NSFMT+FORMAT), A
0011' AF              XOR      A
0012' 32 0470'          LD      (TRACK-NSFMT+FORMAT), A
0015' 21 018C'          LD      HL, SMESG
0018' CD 013E'          CALL   OUTM
001B' CD 014A'          CALL   INPUT
001E' D2 002A'          JP      NC, DATAK
0021' 21 01E2'          DEXIT: LD      HL, BMESG
0024' CD 013E'          CALL   OUTM
0027' C3 0000'          JP      START
002A' 32 0385'          DATAK: LD      (FORMAT+1), A
002D' 21 024D'          LD      HL, LMESG
0030' CD 013E'          CALL   OUTM
0033' CD 014A'          CALL   INPUT
0036' DA 0021'          JP      C, DEXIT
0039' FE 03'            CP      3
003B' CA 0021'          JP      Z, DEXIT
003E' 16 00'            LD      D, 0
0040' 5F              LD      E, A
0041' 21 0182'          LD      HL, STABLE
0044' 19              ADD     HL, DE
0045' 7E              LD      A, M
0046' 32 03DE'          LD      (STRACK-NSFMT+FORMAT), A
0049' D5              PUSH   DE
004A' 21 0215'          LD      HL, DMESG
004D' CD 013E'          CALL   OUTM
0050' CD 014A'          CALL   INPUT
0053' D1              POP    DE
0054' DA 0021'          JP      C, DEXIT
0057' E6 01'            AND     1
0059' 06 51'            LD      B, 051H
005B' CA 0065'          JP      Z, STOREO
005E' F5              PUSH   AF
005F' 0F              RRCA
0060' 83              ADD     A, E
0061' 5F              LD      E, A
0062' F1              POP    AF
0063' 06 D1'            LD      B, 0D1H
0065' 32 03D7'          STOREO: LD      (DEN1-NSFMT+FORMAT), A
0068' 78              LD      A, B
0069' 32 0410'          LD      (DEN2-NSFMT+FORMAT), A
006C' D5              PUSH   DE
006D' 21 02BF'          LD      HL, HMESG
0070' CD 013E'          CALL   OUTM
0073' CD 014A'          CALL   INPUT
0076' D1              POP    DE
0077' DA 0021'          JP      C, DEXIT
007A' E6 01'            AND     1
007C' 32 0450'          LD      (DFLAG-NSFMT+FORMAT), A
007F' CA 0086'          JP      Z, DATAK
0082' 07              RLCA
0083' 07              RLCA

```

0084'	83		ADD	A, E
0085'	5F		LD	E, A
0086'	D5			
0087'	21 0282'	DATA:	PUSH	DE
008A'	CD 013E'		LD	HL, NMESG
008D'	CD 014A'		CALL	OUTM
0090'	D1		CALL	INPUT
0091'	DA 0021'		POP	DE
0094'	E6 01		JP	C, DEXIT
0096'	CA 00AE'		AND	1
0099'	7B		JP	Z, LOADC
009A'	E6 80		LD	A, E
009C'	3E 10		AND	80H
009E'	CA 00A6'		LD	A, 10H
00A1'	21 0105'		JP	Z, STORED
00A4'	19		LD	HL, TYPE-80H
00A5'	7E		ADD	HL, DE
00A6'	32 0406'	STORED:	LD	(CPDATA-NSFMT+FORMAT), A
00A9'	3E E5		LD	A, 0E5H
00AB'	32 0404'		LD	(DATA-NSFMT+FORMAT), A
00AE'	21 0167'	LOADC:	LD	HL, LFD CMD
00B1'	06 0A		LD	B, 0AH
00B3'	CD 011B'		CALL	LCMD
00B6'	21 0176'		LD	HL, DOTCMD
00B9'	06 06		LD	B, 6
00BB'	CD 011B'		CALL	LCMD
00BE'	CA 00DD'		JP	Z, PROCED
00C1'	21 02F4'		LD	HL, RMESG
00C4'	FE 82		CP	82H
00C6'	CA 00CC'		JP	Z, \$+6
00C9'	21 0330'		LD	HL, WMESG
00CC'	CD 013E'		CALL	OUTM
00CF'	CD 014A'		CALL	INPUT
00D2'	DA 0021'		JP	C, DEXIT
00D5'	E6 01		AND	1
00D7'	CA 0000'		JP	Z, START
00DA'	C3 00AE'		JP	LOADC
00DD'	21 0381'	PROCED:	LD	HL, CRLF
00E0'	CD 013E'		CALL	OUTM
00E3'	21 104F		LD	HL, ENTRY
00E6'	22 0177'		LD	(DOTCMD+1), HL
00E9'	3E 2A	CONTUE:	LD	A, "*" "
00EB'	CD 0134'		CALL	OUTPUT
00EE'	21 017C'		LD	HL, ATCMD
00F1'	06 06		LD	B, 6
00F3'	CD 011B'		CALL	LCMD
00F6'	47		LD	B, A
00F7'	3A 03DE'		LD	A, (STRACK-NSFMT+FORMAT)
00FA'	B8		CP	B
00FB'	C2 0107'		JP	NZ, FMTRCK
00FE'	21 036C'	ENDFMT:	LD	HL, FMESG
0101'	CD 013E'		CALL	OUTM
0104'	C3 0000'		JP	START
0107'	21 0176'	FMTRCK:	LD	HL, DOTCMD
010A'	06 06		LD	B, 6
010C'	CD 011B'		CALL	LCMD
010F'	CA 00E9'		JP	Z, CONTUE
0112'	21 02F4'		LD	HL, RMESG
0115'	CD 013E'		CALL	OUTM



0118'	C3 00FE'		JP	ENDFMT
011B'	11 0050	LCMD:	LD	DE, 50H
011E'	7E		LD	A, M
011F'	12		LD	(DE), A
0120'	23		INC	HL
0121'	13		INC	DE
0122'	05		DEC	B
0123'	C2 011E'		JP	NZ, LCMD+3
0126'	D3 EF	ECMD:	OUT	(0EFH), A
0128'	1B		DEC	DE
0129'	1A		LD	A, (DE)
012A'	B7		OR	A
012B'	CA 0129'		JP	Z, ECMD+3
012E'	3A 0053		LD	A, (53H)
0131'	FE 40		CP	40H
0133'	C9		RET	
0134'	21 0172'	OUTPUT:	LD	HL, SOCMD+1
0137'	06 05		LD	B, 5
0139'	77		LD	M, A
013A'	2B		DEC	HL
013B'	C3 011B'		JP	LCMD
013E'	7E	OUTM:	LD	A, M
013F'	B7		OR	A
0140'	C8		RET	Z
0141'	E5		PUSH	HL
0142'	CD 0134'		CALL	OUTPUT
0145'	E1		POP	HL
0146'	23		INC	HL
0147'	C3 013E'		JP	OUTM
014A'	21 003F	INPUT:	LD	HL, 3FH
014D'	3E 40		LD	A, 40H
014F'	96		SUB	M
0150'	C2 014D'		JP	NZ, INPUT+3
0153'	77		LD	M, A
0154'	2B		DEC	HL
0155'	7E		LD	A, M
0156'	F5		PUSH	AF
0157'	CD 0134'		CALL	OUTPUT
015A'	F1		POP	AF
015B'	E6 7F		AND	7FH
015D'	FE 30		CP	30H
015F'	D8		RET	C
0160'	FE 34		CP	34H
0162'	3F		CCF	
0163'	D8		RET	C
0164'	E6 03		AND	3
0166'	C9		RET	

PAGE

0167'	A1	LFD CMD:	DB	0A1H
0168'	0384'		DW	FORMAT
016A'	00		DB	0
016B'	00EE		DW	ECODE-FORMAT
016D'	1030		DW	1030H
016F'	25		DB	25H
0170'	00		DB	0
0171'	2B	SOC MD:	DB	2BH
0172'	00		DB	0
0173'	00		DB	0
0174'	25		DB	25H
0175'	00		DB	0
0176'	A2	DOT CMD:	DB	0A2H
0177'	1030		DW	1030H
0179'	00		DB	0
017A'	25		DB	25H
017B'	00		DB	0
017C'	A2	ATC MD:	DB	0A2H
017D'	1114		DW	ADVTRK
017F'	00		DB	0
0180'	25		DB	25H
0181'	00		DB	0
0182'	23	STABLE:	DB	35
0183'	28		DB	40
0184'	50		DB	80
0185'	90	TYPE:	DB	90H
0186'	A0		DB	0A0H
0187'	C0		DB	0C0H
0188'	00		DB	0
0189'	F0		DB	0F0H
018A'	D0		DB	0D0H
018B'	E0		DB	0E0H
				PAGE

```

018C' 0D0A          SMESSG: DW  CRLFS
018E' 4E 6F 72 74          DB  "North Star Compatable 5 1/4 inch Format Program"
0192' 68 20 53 74
0196' 61 72 20 43
019A' 6F 6D 70 61
019E' 74 61 62 6C
01A2' 65 20 35 20
01A6' 31 2F 34 20
01AA' 69 6E 63 68
01AE' 20 46 6F 72
01B2' 6D 61 74 20
01B6' 50 72 6F 67
01BA' 72 61 6D
01BD' 0D0A          DW  CRLFS
01BF' 53 65 6C 65          DB  "Select a Drive ( 0, 1, 2, or 3 ): "
01C3' 63 74 20 61
01C7' 20 44 72 69
01CB' 76 65 20 28
01CF' 20 30 2C 20
01D3' 31 2C 20 32
01D7' 2C 20 6F 72
01DB' 20 33 20 29
01DF' 3A 20
01E1' 00          DB  0
01E2' 0D0A          SMESSG: DW  CRLFS
01E4' 49 6D 70 72          DB  "Improper input - returning to start of program"
01E8' 6F 70 65 72
01EC' 20 69 6E 70
01F0' 75 74 20 2D
01F4' 20 72 65 74
01F8' 75 72 6E 69
01FC' 6E 67 20 74
0200' 6F 20 73 74
0204' 61 72 74 20
0208' 6F 66 20 70
020C' 72 6F 67 72
0210' 61 6D
0212' 0D0A          DW  CRLFS
0214' 00          DB  0
0215' 0D0A          DMESG: DW  CRLFS
0217' 53 65 6C 65          DB  "Select double density ( 1 ) or single density ( 0 ): "
021B' 63 74 20 64
021F' 6F 75 62 6C
0223' 65 20 64 65
0227' 6E 73 69 74
022B' 79 20 28 20
022F' 31 20 29 20
0233' 6F 72 20 73
0237' 69 6E 67 6C
023B' 65 20 64 65
023F' 6E 73 69 74
0243' 79 20 28 20
0247' 30 20 29 3A
024B' 20
024C' 00          DB  0
024D' 0D0A          LMESG: DW  CRLFS
024F' 53 65 6C 65          DB  "Select the number of tracks ( 0=35, 1=40, 2=80 ): "

```

```

0253' 63 74 20 74
0257' 68 65 20 6E
025B' 75 6D 62 65
025F' 72 20 6F 66
0263' 20 74 72 61
0267' 63 6B 73 20
026B' 28 20 30 3D
026F' 33 35 2C 20
0273' 31 3D 34 30
0277' 2C 20 32 3D
027B' 38 30 20 29
027F' 3A 20
0281' 00
0282' 0D0A
0284' 53 65 6C 65
0288' 63 74 20 4E
028C' 6F 72 74 68
0290' 20 53 74 61
0294' 72 20 28 20
0298' 30 20 29 20
029C' 6F 72 20 43
02A0' 50 2F 4D 20
02A4' 20 20 31 20
02A8' 29 20 64 61
02AC' 74 61 20 63
02B0' 6F 6D 70 61
02B4' 74 69 62 69
02B8' 6C 69 74 79
02BC' 3A 20
02BE' 00
02BF' 0D0A
02C1' 53 65 6C 65
02C5' 63 74 20 73
02C9' 69 6E 67 6C
02CD' 65 20 28 20
02D1' 30 20 29 20
02D5' 6F 72 20 64
02D9' 6F 75 62 6C
02DD' 65 20 28 20
02E1' 31 20 29 20
02E5' 73 69 64 65
02E9' 64 20 6D 65
02ED' 64 69 61 20
02F1' 3A 20
02F3' 00
02F4' 0D0A
02F6' 44 72 69 76
02FA' 65 20 6E 6F
02FE' 74 20 72 65
0302' 61 64 79 20
0306' 2D 20 72 65
030A' 73 74 61 72
030E' 74 20 70 72
0312' 6F 67 72 61
0316' 6D 3F 20 28
031A' 20 30 20 29
031E' 20 6F 72 20
0322' 63 79 63 6C
0326' 65 20 28 20

```

```

DB 0
NMESG: DW CRLFS
DB "Select North Star ( 0 ) or CP/M ( 1 ) data compatibility: "

```

```

DB 0
HMESG: DW CRLFS
DB "Select single ( 0 ) or double ( 1 ) sided media : "

```

```

DB 0
RMESG: DW CRLFS
DB "Drive not ready - restart program? ( 0 ) or cycle ( 1 ); "

```

```

032A' 31 20 29 3A
032E' 20
032F' 00
0330' 0D0A
0332' 57 72 69 74
0336' 65 20 70 72
033A' 6F 74 65 63
033E' 74 65 64 20
0342' 2D 20 72 65
0346' 73 74 61 72
034A' 74 20 70 72
034E' 6F 67 72 61
0352' 6D 3F 20 28
0356' 20 30 20 29
035A' 20 6F 72 20
035E' 63 79 63 6C
0362' 65 20 28 20
0366' 31 20 29 3A
036A' 20
036B' 00
036C' 0D0A
036E' 46 6F 72 6D
0372' 61 74 74 69
0376' 6E 67 20 66
037A' 69 6E 69 73
037E' 68 65 64
0381' 0D0A
0383' 00
    
```

```

DB 0
WMESG: DW CRLFS
DB "Write protected - restart program? ( 0 ) or cycle ( 1 ); "
    
```

```

DB 0
FMESG: DW CRLFS
DB "Formatting finished"
    
```

```

CRLF: DW CRLFS
DB 0
PAGE
    
```

```

0384'
1030 3E 00
1032 CD 00A6
1035 C0
1036 DD 36 0B 00
103A FD 7E 02
103D F6 0E
103F 32 4004
1042 CD 00A9
1045 3E 82
1047 C8
1048 CD 00A0
104B CB 6E
104D 28 F6
104F DD 36 0B 00
1053 3A 11C
1056 FD BE 01
1059 C4 00A3
105C 3A 4003
105F E6 40
1061 3E 90
1063 C0
1064 DD 36 0A 00
1068 CD 00A9
106B 28 D8
106D AF
106E DD BE 0A
1071 20 F5
1073 3E 90
1075 32 4007
1078 21 4001
107B 0E 00
107D DD 71 09
1080 06 11
1082 3E 00
1083
1084 1F
1085 3E 64
1087 30 0F
1089 3E 18
108A
108B 1F
108C C6 05
108E FD BE 01
1091 9F
1092 E6 10
1094 F6 24
1096 06 20
1098 32 4006

109B 36 00
109D E3
109E E3
109F 10 FA
10A1 3A 1083
10A4 B7

FORMAT EQU $
.PHASE 1030H
NSFMT: LD A,0
CALL SDRIVE
RET NZ
LD (IX+0BH),0
LD A,(IY+2)
OR 0EH
LD (4004H),A
CALL HSYNC
NREXIT: LD A,82H
RET Z
TRACK0: CALL HOME
BIT 5,M
JR Z,NREXIT
ENTRY: LD (IX+0BH),0
LD A,(TRACK)
CP (IY+1)
CALL NZ,SEEK
LD A,(4003H)
AND 40H
LD A,90H
RET NZ
LD (IX+0AH),80H
WSECT0: CALL HSYNC
JR Z,NREXIT
XOR A
CP (IX+0AH)
JR NZ,WSECT0
LD A,90H
LD (CONTRL),A
LD HL,DISK
LD C,0
LD (IX+9),C
LD B,11H
LD A,0
DEN1 EQU $-1
RRA
LD A,64H
JR NC,CSTART
LD A,18H
STRACK EQU $-1
RRA
ADD A,5
CP (IY+1)
SBC A,A
AND 10H
OR 24H
LD B,20H
CSTART: LD (4006H),A

ZEROW: LD M,0
EX (SP),HL
EX (SP),HL
DJNZ ZEROW
LD A,(DEN1)
OR A

```

10A5	28 04	JR	Z, LASTS
10A7	36 FB	LD	M, 0FBH
10A9	E3	EX	(SP), HL
10AA	E3	EX	(SP), HL
10AB	36 FB	LD	M, 0FBH
10AD	06 5C	LD	B, 5CH
10AF	1E 20	LD	E, 20H
10B0		DATA EQU	\$-1
10B1	16 20	LD	D, 20H
10B2		CPDATA EQU	\$-1
10B3	AF	XOR	A
10B4	E3	D1LOOP: EX	(SP), HL
10B5	E3	EX	(SP), HL
10B6	73	LD	M, E
10B7	AB	XOR	E
10B8	07	RLCA	
10B9	10 F9	DJNZ	D1LOOP
10BB	06 51	LD	B, 51H
10BC		DEN2 EQU	\$-1
10BD	E3	EX	(SP), HL
10BE	E3	EX	(SP), HL
10BF	72	LD	M, D
10C0	AA	XOR	D
10C1	07	RLCA	
10C2	08	EX	AF, AF'
10C3	7B	LD	A, E
10C4	32 10B2	LD	(CPDATA), A
10C7	08	EX	AF, AF'
10C8	E3	EX	(SP), HL
10C9	E3	EX	(SP), HL
10CA	73	LD	M, E
10CB	AB	XOR	E
10CC	07	RLCA	
10CD	E3	D2LOOP: EX	(SP), HL
10CE	E3	EX	(SP), HL
10CF	73	LD	M, E
10D0	AB	XOR	E
10D1	07	RLCA	
10D2	E3	EX	(SP), HL
10D3	E3	EX	(SP), HL
10D4	73	LD	M, E
10D5	AB	XOR	E
10D6	07	RLCA	
10D7	10 F4	DJNZ	D2LOOP
10D9	E3	EX	(SP), HL
10DA	E3	EX	(SP), HL
10DB	77	LD	M, A
10DC	3A 10B3	LD	A, (DEN1)
10DF	B7	OR	A
10E0	06 11	LD	B, 11H
10E2	28 02	JR	Z, \$+4
10E4	06 20	LD	B, 20H
10E6	E3	ILOOP: EX	(SP), HL
10E7	E3	EX	(SP), HL
10E8	73	LD	M, E
10E9	3A 4003	LD	A, (STATUS)
10EC	E6 10	AND	INDEX
10EE	28 F6	JR	Z, ILOOP
10F0	0C	INC	C

```

10F1    3E 0A          LD    A,0AH
10F3    B9            CP    C
10F4    20 A5         JR    NZ,ZEROW
10F6    0E 00         LD    C,0
10F8    3A 111D       LD    A,(DSIDE)
10FB    EE 00         XOR   0
10FC                    DFLAG EQU  $-1
10FD    32 111D       LD    (DSIDE),A
1100    28 0C         JR    Z,FTDONE
1102    FD 7E 02      LD    A,(IY+2)
1105    F6 0E         OR   0EH
1107    E6 FD         AND  0FDH
1109    32 4004       LD    (4004H),A
110C    18 8D         JR    ZEROW
110E    32 4007       FTDONE: LD (CONTRL),A ;turn off write gate
1111    3E 40         LD    A,40H
1113    C9            RET
1114    3A 111C       ADVTRK: LD  A,(TRACK) ;get the current track
1117    3C            INC  A ;advance track value
1118    32 111C       LD    (TRACK),A ;update the track value
111B    C9            RET ;return with track value
111C    00           TRACK: 0
111D    00           DSIDE: 0
                        .DEPHASE
0472'   ECODE EQU  $
                        END

```



**COMPONENT LAYOUT/SCHEMATIC**

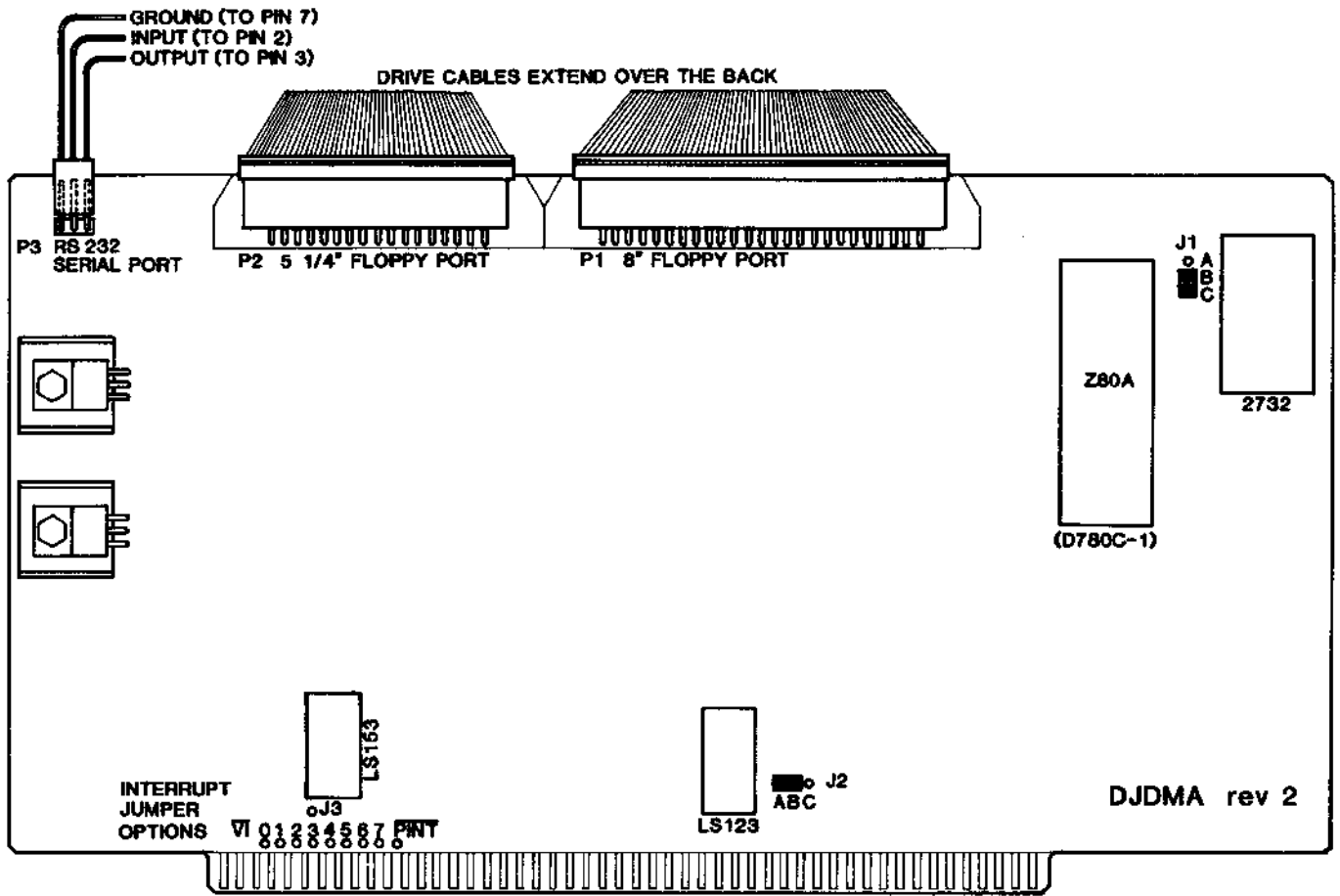

**Disk Jockey / DMA Component Layout**

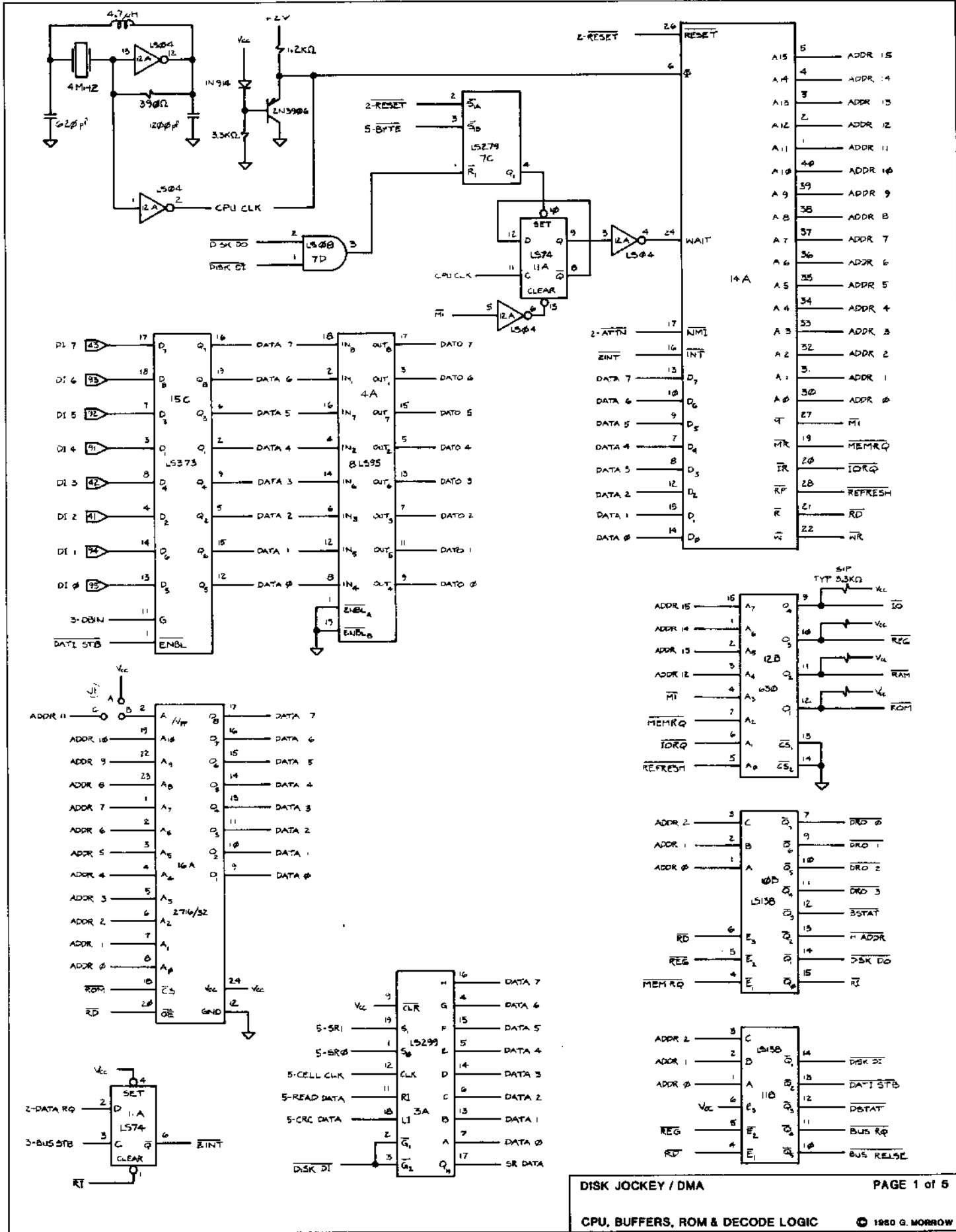

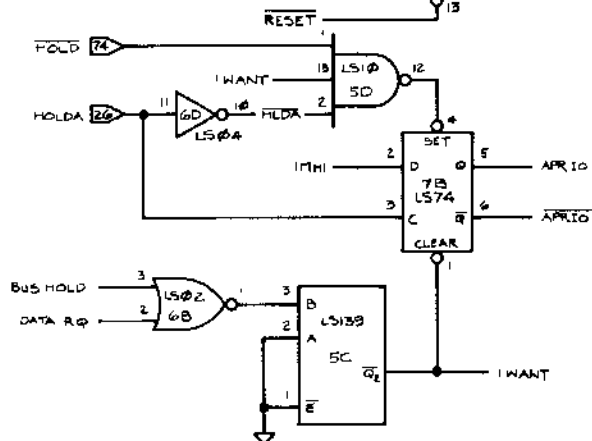
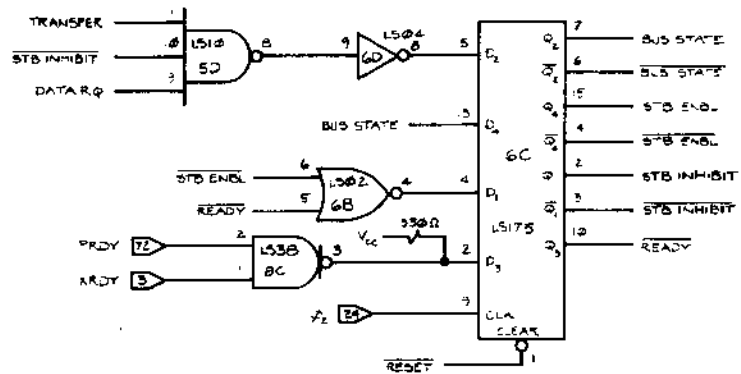
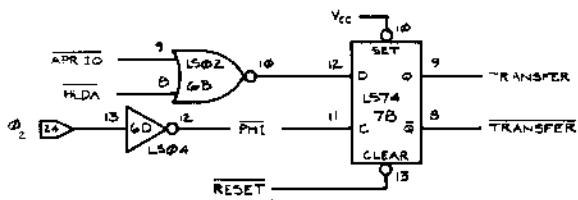
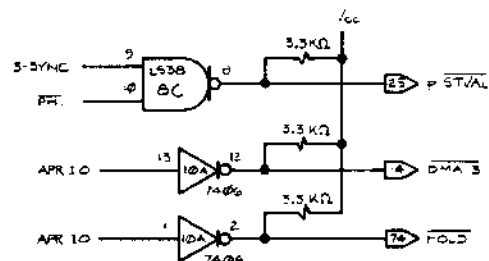
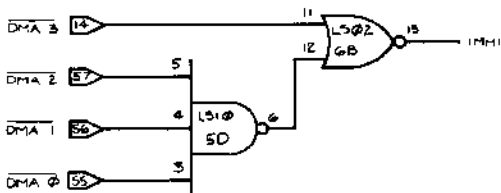
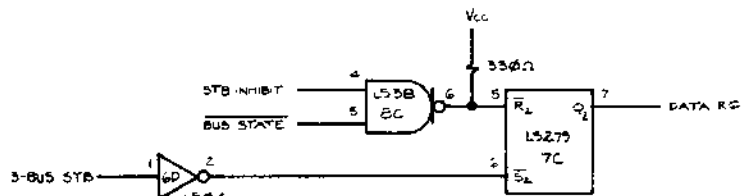
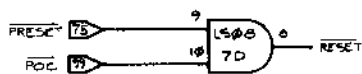
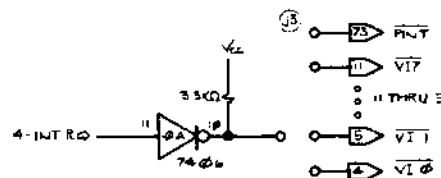
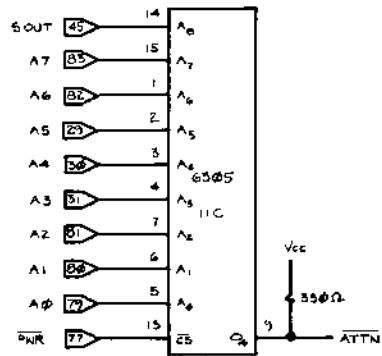
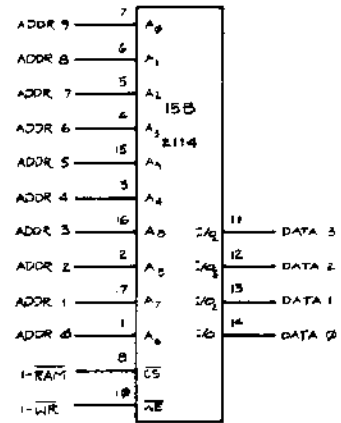
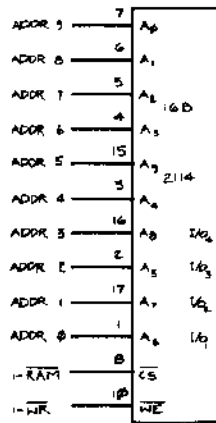
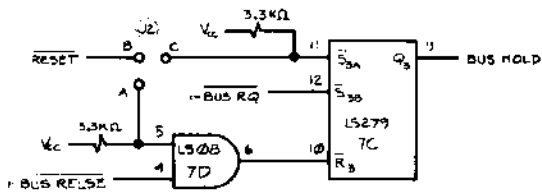

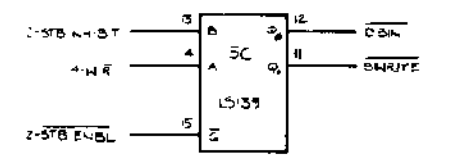
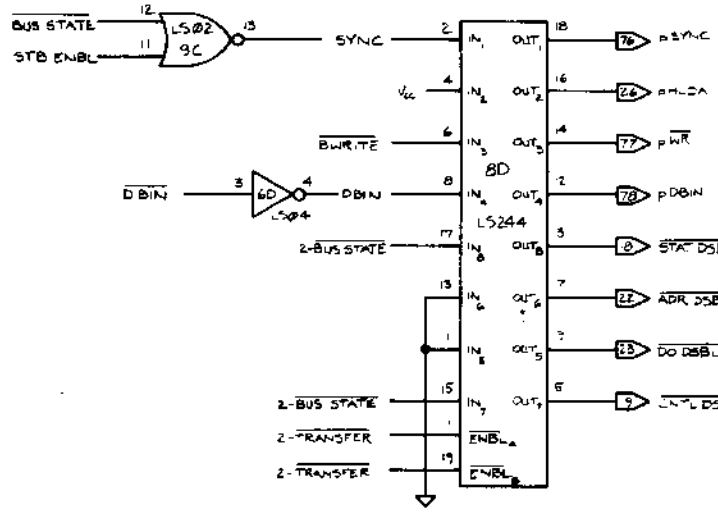
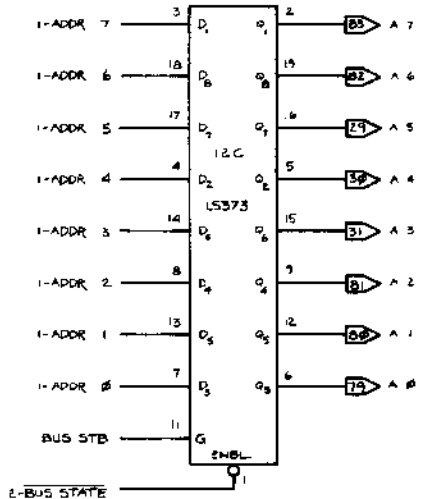
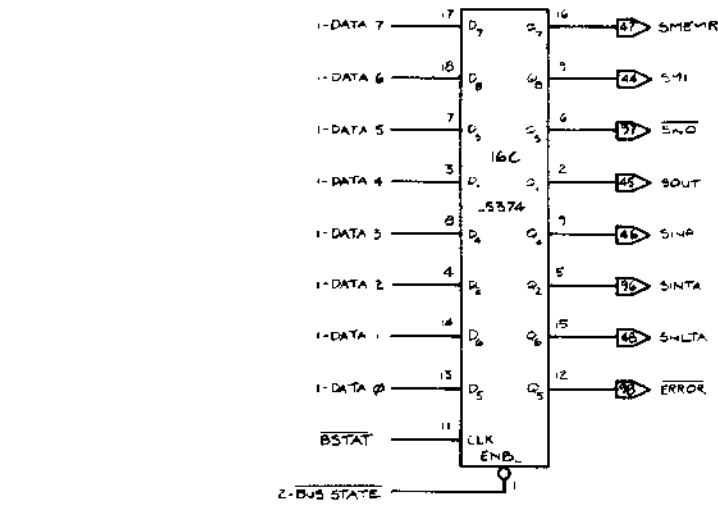
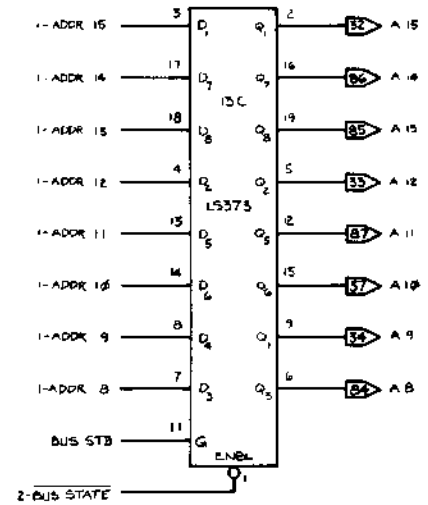
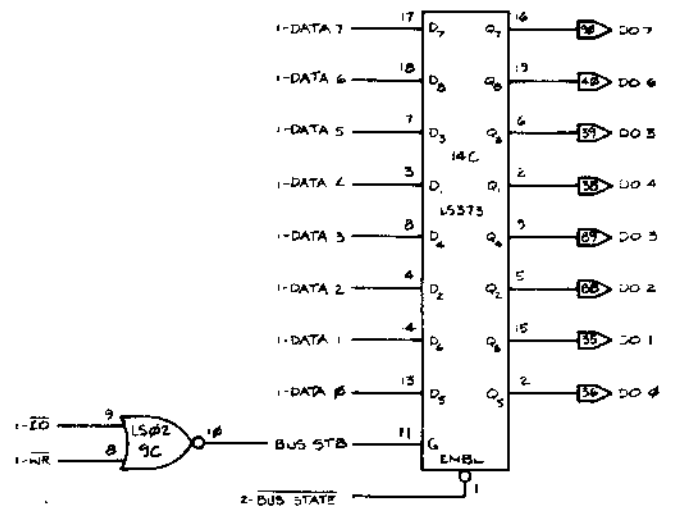
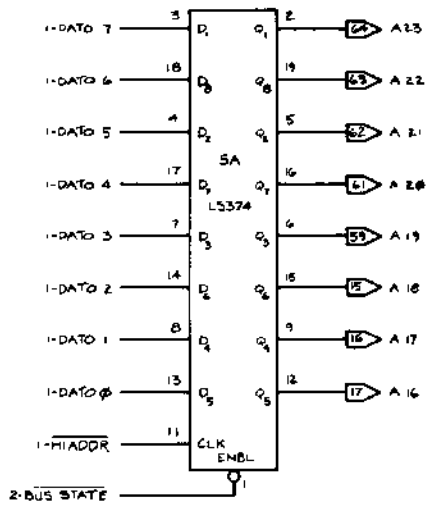

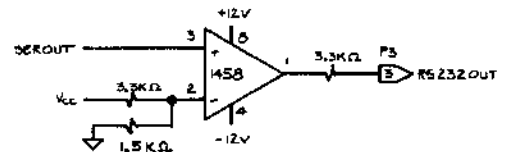
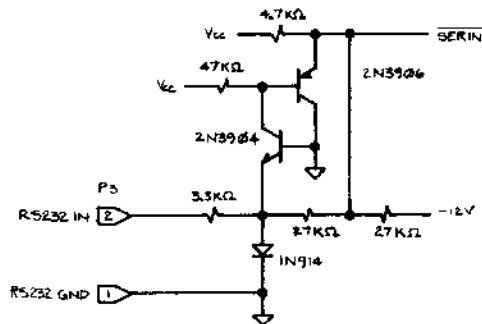
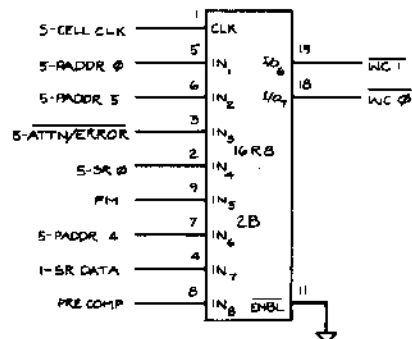
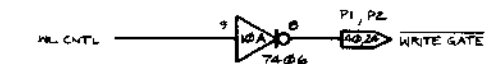
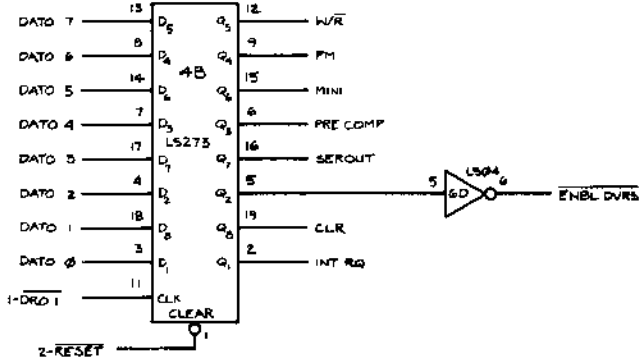
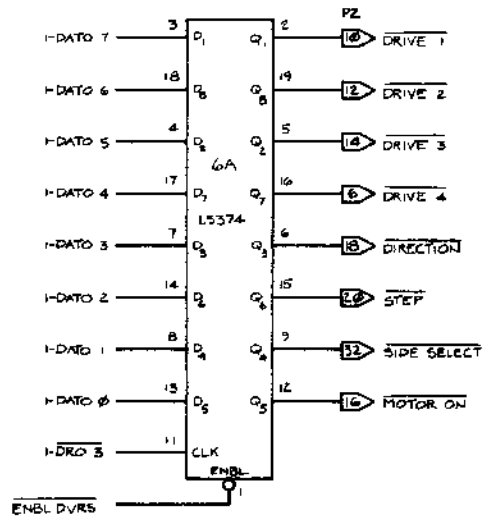
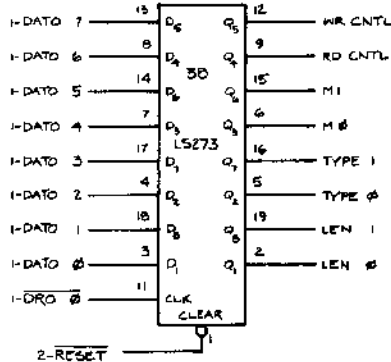
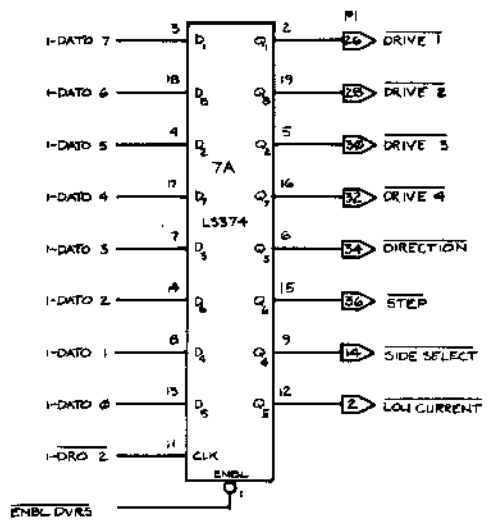
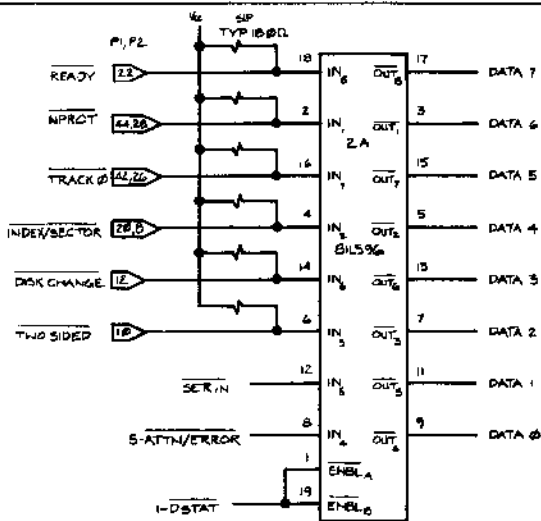

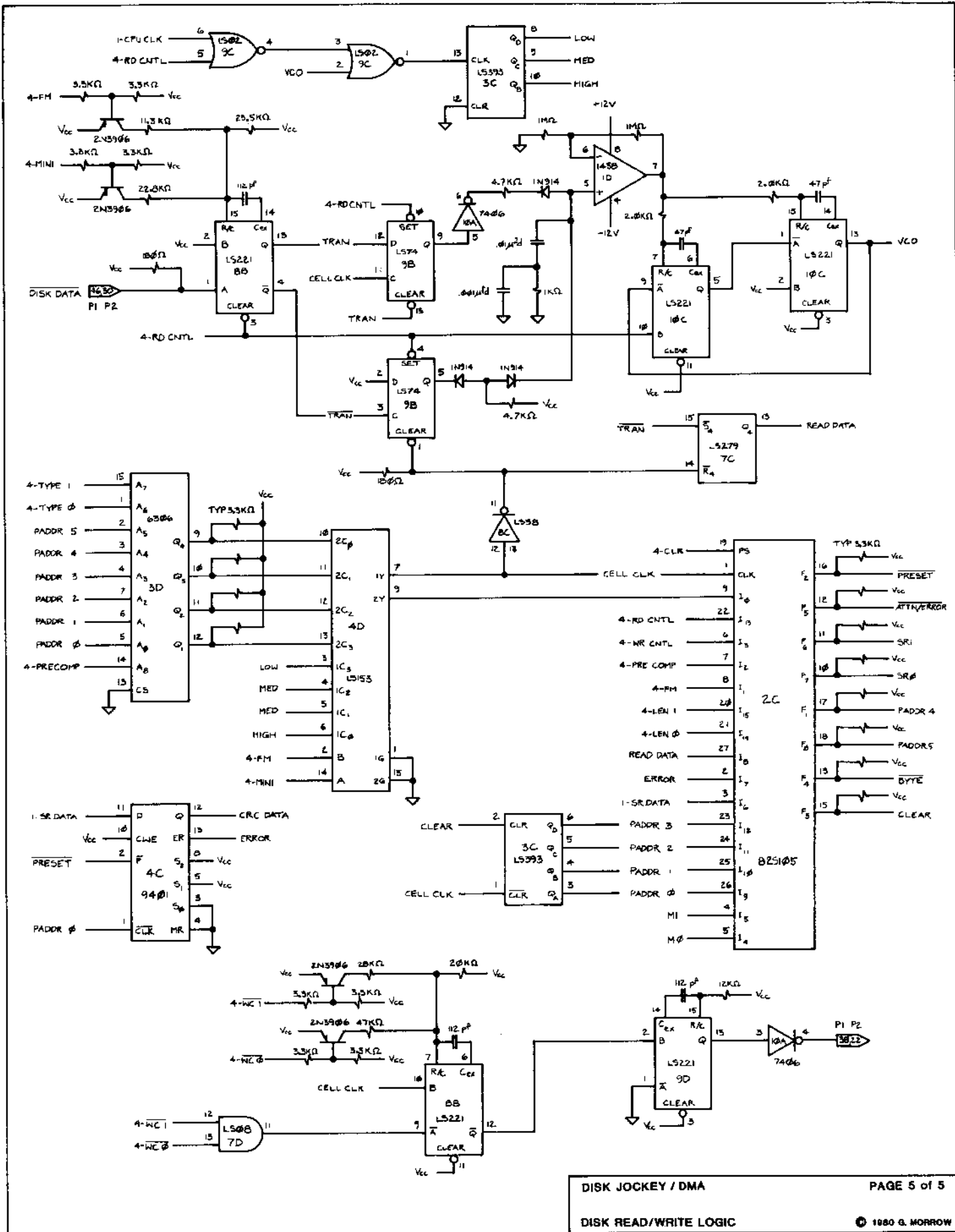

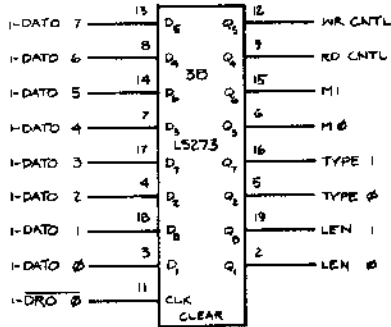
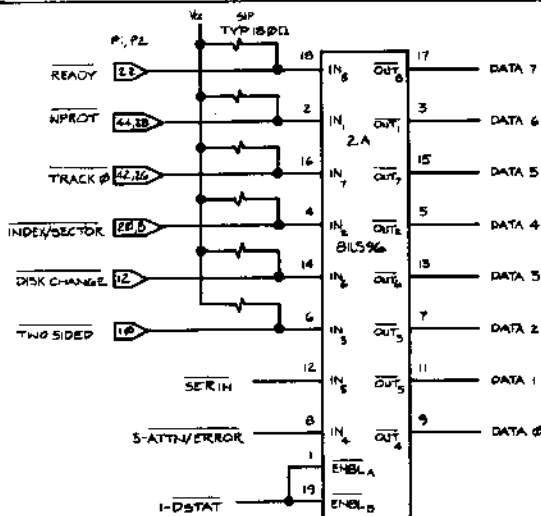
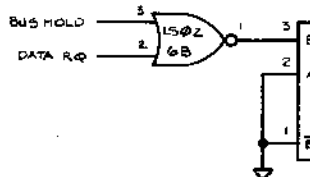
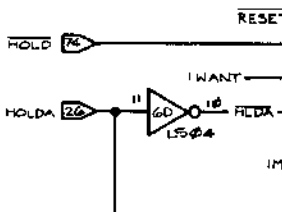
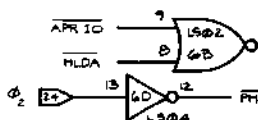
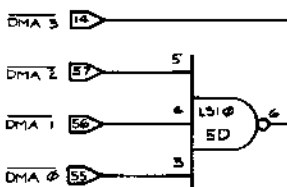
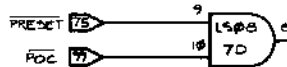
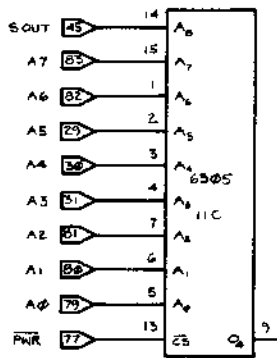
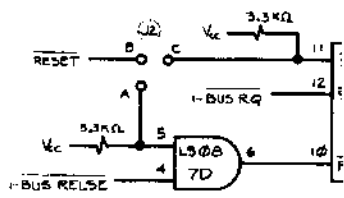

2-RESET

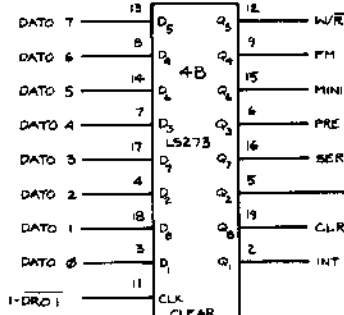

2-RESET

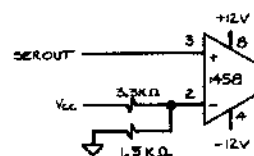
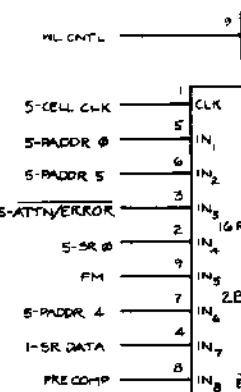
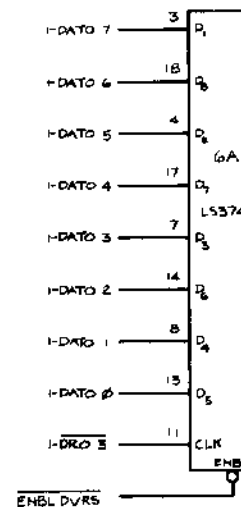
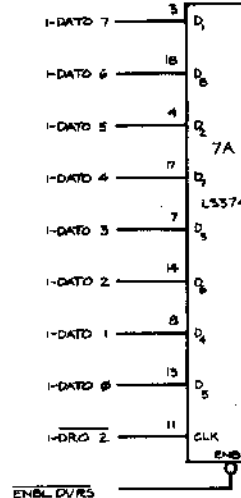
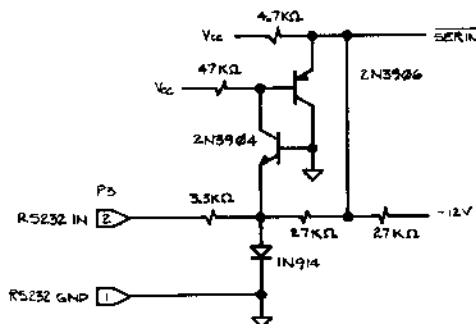

DISK JOCKEY / DMA  
DRIVE & CONTROL REGISTERS