

28 TELETYPEWRITER BASES

(KEYBOARD SEND-RECEIVE AND RECEIVE ONLY)

WIRING DIAGRAMS

1. GENERAL

1.01 This section shows the wiring of the LK16 (Bell 28D), LK50 (Bell 28D-1), LK22 (Bell 28E), LK26 (Bell 28G), LK46 (Bell 28H), LK47 (Bell 28H-1), LK14 (Bell 28J), LK27 (Bell 28K), and LK45 (Bell 28M) keyboard send-receive teletypewriter bases. It also includes LB4/146 (Bell 28B), LB4/218 (Bell 28B-1), LB9/146 (Bell 28F), and LB31 (Bell 28L) receive only teletypewriter bases.

1.02 The section is reissued to update format and to include the 28D-1, 28E, 28F, and 28M bases. Since the 28A, 28C, and 28C-1 bases are no longer manufactured, their associated wiring diagrams have been deleted.

1.03 Notes on the wiring diagrams explain symbols used and point out special conditions. These diagrams show origin and termination of various leads as well as color coding of the leads for each of the components.

2. WIRING DIAGRAM INDEX (ATTACHMENTS)

TITLE	WIRING DIAGRAM	SHEET NO.	WD ISSUE
Receive Only Base LB4/146 (Bell 28B), LB4/218 (Bell 28B-1)	2883WD	1	25
Keyboard LK14 (Bell 28J), LK16 (28D)	2928WD	1	24
Receive Only Base LB9/146 (Bell 28F)	3810WD	1	1
Keyboard LK22 (Bell 28E)	3814WD	1	1
Keyboard Base LK26 (Bell 28G)	4343WD	1	C
Keyboard Base LK27 (Bell 28K)	4484WD	1	12
Keyboard LK46 (Bell 28H), LK47 (Bell 28H-1)	4906WD	1	5
Receive Only Base LB31 (Bell 28L)	5860WD	1	7
Keyboard LK45 (Bell 28M)	6486WD	1	A2
Keyboard LK50 (Bell 28D-1)	7160WD	1	3

REVISIONS

ISSUE	DATE	AUTH. NO.
12	11-5-54	28-4597
13	1-26-55	28-4871
14	2-2-55	28-4911
5	2-16-55	28-4911-1
6	3-2-55	28-5054
7	3-11-55	28-5096
8	5-16-55	28-5395
9	9-3-55	28-5728
10	6-29-56	28-6799
11	8-31-56	28-6879
12	9-4-56	28-6905
13	12-14-56	28-7261
14	2-19-57	28-7414
15	3-24-59	28-10789
16	9-9-59	28-11778
17	9-14-59	28-11694
18	2-5-60	28-12554
19	10-4-61	71140
20	10-30-61	71425
21	10-1-63	77302
22	12-13-63	79185
23	3-31-65	86474
24	2-16-67	92028
25	3-15-68	95297

- NOTES**
- POWER CIRCUITS WIRED FOR 115V AC OR DC OPERATION.
 - WIRE COLOR CODE:
BK-BLACK P-PURPLE
BL-BLUE R-RED
BR-BROWN Y-YELLOW
W-WHITE G-GREEN
S-SLATE O-ORANGE
 - CONNECTOR AND SWITCHES VIEWED FROM SOLDER TERMINAL ENDS.
 - DENOTES BASIC WIRING.
- - - DENOTES LEADS FURNISHED WITH ACCESSORY GROUP
 - STRAP NECESSARY FOR OPERATION WITH LESU 7.
 - WHEN THE PAPER-FEED OUT MOTOR START SWITCH IS SUPPLIED, MOTOR LEAD CONNECTS TO TERMINAL 3 OF MOTOR TERMINAL BLOCK INSTEAD OF TERMINAL 1.
 - LOCAL-REMOTE SWITCH SHOULD HAVE A SLOT IN SWITCH TO THE LEFT OR TOWARD THE "LOCAL" SIDE.
 - WHEN BUSY SWITCH ACCESSORY IS USED CONNECT LEADS TO TERMINALS 9 & 10.
 - WHEN WIRING LB4/249 & LB200**/252 CONNECT RED WIRE TO TERMINAL 17 AND YELLOW WIRE TO 19.
 - 161525 PLUG CONNECTOR PART OF 164133 CABLE ASSEMBLY - MATES WITH 161526 RECEPTACLE ON 163905 PLATE ASSEMBLY IN LESU45 (LBB/253).
 - 195259 STRAP CONNECTED FROM TERMINAL 3 TO COVER MOUNTING SCREW OF MOTOR TERM. BOARD FOR 179613 R.F. SUPPRESSION MODIFICATION KIT.
 - FOR ACCESSORY CABLE ROUTING SEE ASSOCIATED SPECIFICATION.
 - FOR SCHEMATIC SEE ASSOCIATED LESU WD.
 - * DENOTES 18 GA. WIRE.

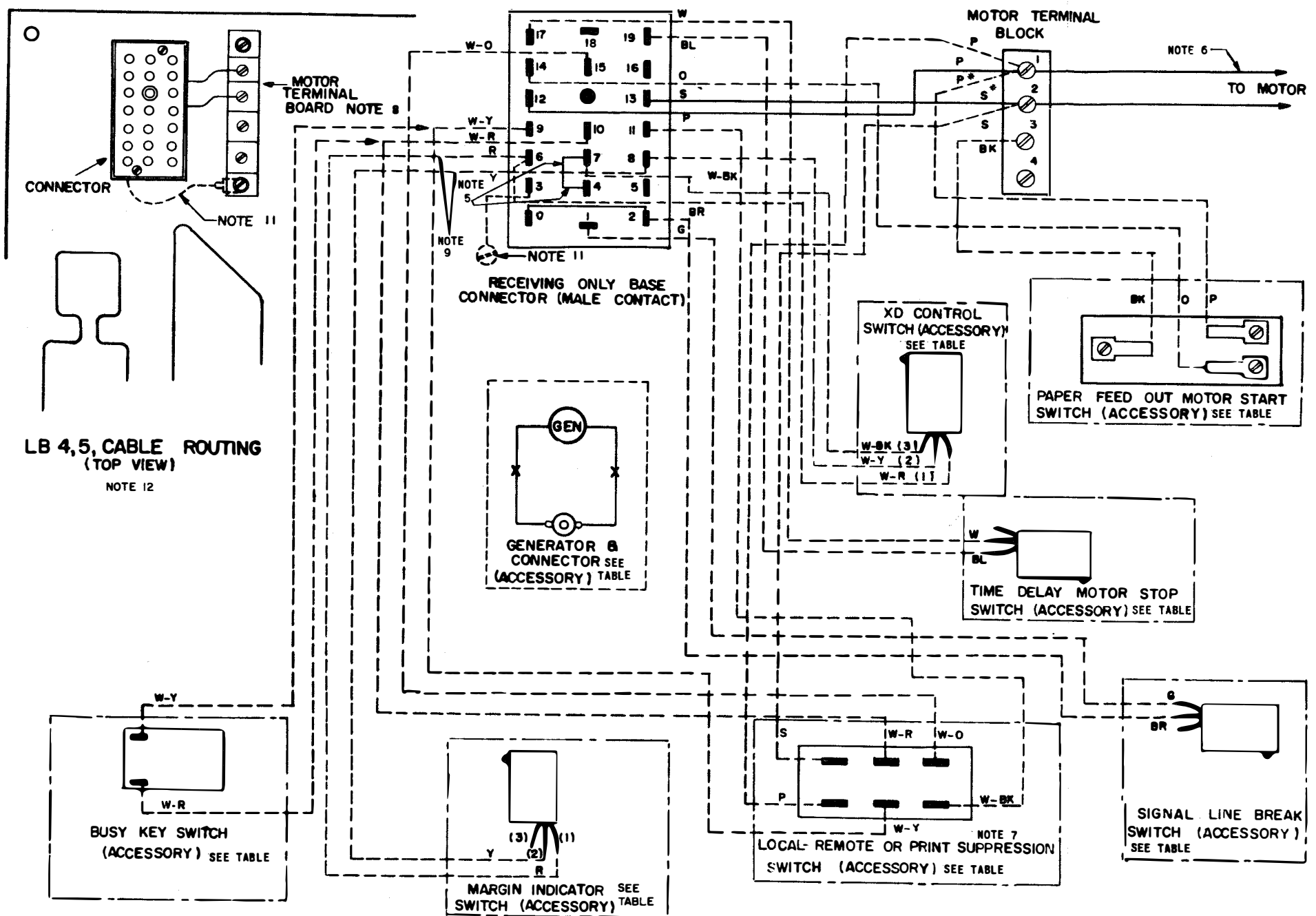

ACCESSORY GROUP NUMBER	XD CONTROL SWITCH 154794	BUSY KEY SWITCH 156359	GENERATOR FOR TACHOMETER 154749	PAPER FEED OUT MOTOR START SWITCH 152334	LOCAL-REMOTE SWITCH ASSEMBLY 152342	MARGIN INDICATOR SWITCH ASSEMBLY 152343	SIGNAL LINE BREAK SWITCH ASSEMBLY 152344	TIME DELAY MOTOR STOP SWITCH ASSEM. 152338	PRINT-SUPPRESSION SWITCH ASSEM. 154681	JACK ASSEMBLY FOR TACHOMETER 97143	323708-323710 CONTROL PUSH BUTTONS & 164133 CABLE ASSEMBLY (LBB ONLY)
133					X	X					
146									X		
160								X			
161											
180				X							
202	X		X							X	
207	X										
218		X									
249						X					
252						X					
253							X				X
259						X			X		

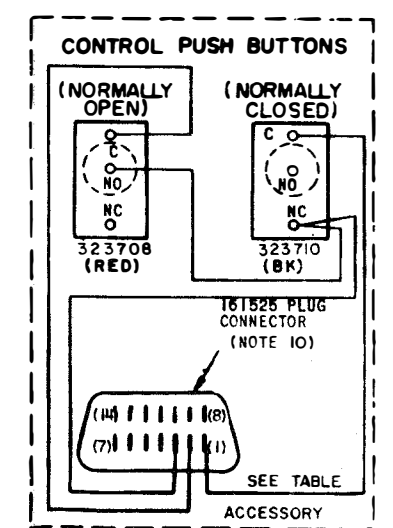

ACTUAL WIRING DIAGRAM FOR MODEL 28 RECEIVING ONLY BASE LB4, 5, 8, 12, 29, 200 ACCESSORY GROUPS 133, 146, 160, 161, 180, 202, 207, 218, 249, 252, 253, 259

APPROVALS

D AND R E OF M

E-NUMBER

PROD. NO. 2883WD

DATE 9-1-54

P.D. FILE NO. 1-30.65-11A

DRAWN J.G.W. CHKD.

ENGD. R.J.R. APPD.

TELETYPE CORPORATION

REVISIONS

ISSUE	DATE	AUTH. NO.
17	5 - 2 - 63	76756
18	3 - 26 - 64	79225 - 1
19	12 - 22 - 65	89377
20	2 - 28 - 66	89635
21	6 - 9 - 67	94014
22	3-15-68	95483
23	3-18-68	95297
24	3-26-68	94014-1

- 1. WIRING LEGEND:**
DISTANT TERMINATING AREA
DISTANT TERMINATING DESIGNATION
A-11-BK
WIRE COLOR CODE
- 2. WIRE COLOR CODE:**
- | | |
|------------|------------|
| BK - BLACK | Y - YELLOW |
| BL - BLUE | O - ORANGE |
| BR - BROWN | W - WHITE |
| G - GREEN | R - RED |
| S - SLATE | P - PURPLE |
- 3. POWER CIRCUITS WIRED FOR 115V AC OR DC OPERATION.**
- 4. CONNECTORS VIEWED FROM SOLDER TERMINALS ENDS.**
- 5. ALL LEADS ARE FURNISHED WITH OPTIONAL ELECTRICAL COMPONENTS.**
- 6. STRAP NECESSARY FOR OPERATION WITH LESU7 AND LESU92**
- 7. WHEN THE PAPER FEED-OUT MOTOR START SWITCH IS SUPPLIED, NO. 1 MOTOR LEAD CONNECTS TO TERMINAL 3 INSTEAD OF TERMINAL 1 OF MOTOR TERMINAL BLOCK**
- 8. GROUND STRAP TERMINATES AT TOP OF KEYBOARD BASE LOWER PLATE BY MEANS OF LEFT FRONT 151549 KEYBOARD SPECIAL MOUNTING SCREW.**
- 9. FOR PROPER R.F. FILTERING, POLARITY MUST BE MAINTAINED WHEN 154190 AND 172976 FILTERS ARE USED. UNIT AS FURNISHED IS WIRED FOR MARKING CONTACTS POSITIVE (+), SPACING CONTACT NEGATIVE (-). TO REVERSE POLARITY ON CONTACTS SO THAT THE MARKING CONTACT IS NEGATIVE (-) AND SPACING CONTACT IS POSITIVE (+), MAKE THE FOLLOWING CONNECTIONS IN THE CONTACT BOX ASSEMBLY:
172976 FILTERS ARE USED. UNIT AS FURNISHED IS WIRED FOR MARKING CONTACTS POSITIVE (+), SPACING CONTACT NEGATIVE (-). TO REVERSE POLARITY ON CONTACTS SO THAT THE MARKING CONTACT IS NEGATIVE (-) AND SPACING CONTACT IS POSITIVE (+), MAKE THE FOLLOWING CONNECTIONS IN THE CONTACT BOX ASSEMBLY:
1. MOVE BLACK LEAD OF BOTTOM FILTER FROM "MARKING" CONTACT TO "SPACING" CONTACT.
2. MOVE GREEN LEAD OF TOP FILTER FROM "SPACING" CONTACT TO "MARKING" CONTACT.
POLARITY MAY BE DISREGARDED WHEN UNITS ARE FURNISHED WITH 195923 FILTERS. COLOR CODING OF FILTER LEADS DOES NOT APPLY TO 195923 FILTERS**
- 10. UNITS ARE EQUIPPED WITH 172976 OR 195923 R.F. AND ARC SUPPRESSOR TO FILTER SPACING CONTACT.**
- 11. ON LK37, ATTACH LEADS FROM LINE BREAK SWITCH TO KEYBOARD CONNECTOR AS FOLLOWS:
WHITE LEAD TO F-18
GREEN LEAD TO F-3
BROWN LEAD TO F-1**
- 12. TOGGLE STRAP-USE ONLY ON LK66 BUT BEFORE A UNIT IS INSTALLED IN A LOW VOLTAGE SIGNALING APPLICATION THE 154166 ARC SUPPRESSOR MUST BE REMOVED**
- 13. * DENOTES 18 GA. WIRE.**
- 14. THE LK66 IS WIRED THE SAME AS THIS EXCEPT DOES NOT HAVE THE ARC SUPPRESSOR.**

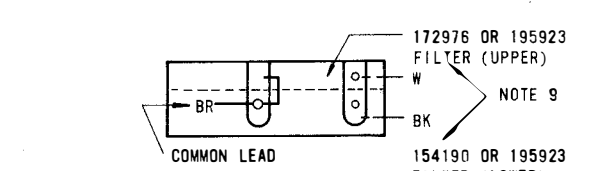
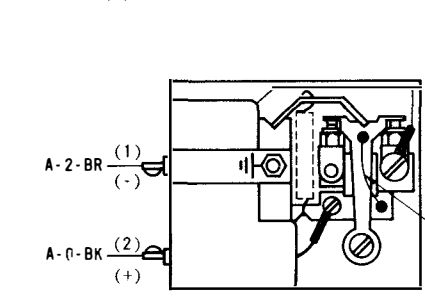
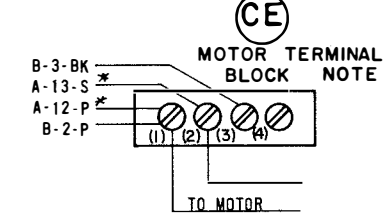
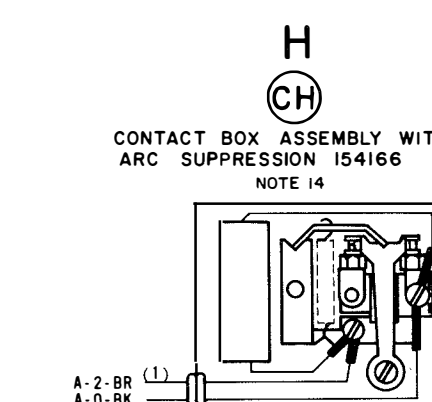
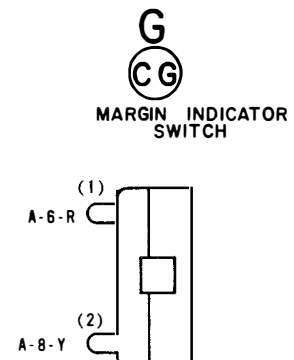
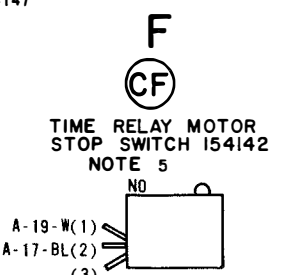
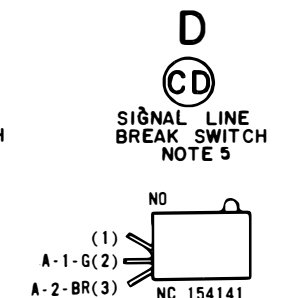
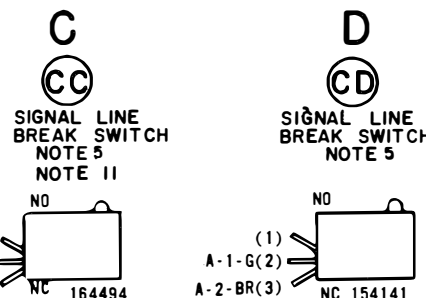
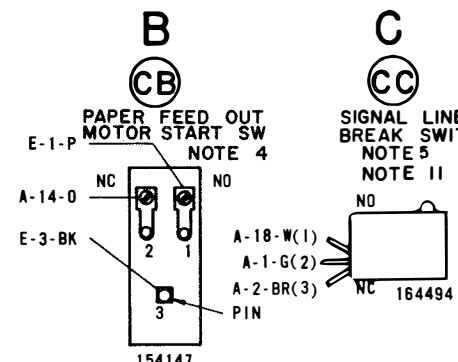
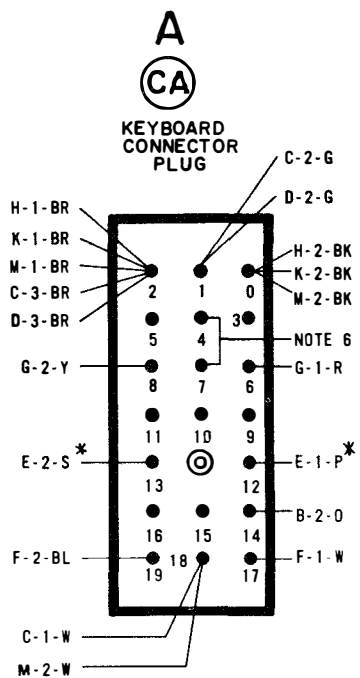

OPTIONAL ELECTRICAL COMPONENTS

UNIT CODE	ARC SUPPRESSION ONLY	R.F. & ARC SUPPRESSION	SIGNAL LINE BREAK	TIME DELAY	PAPER FEED OUT	SIGNAL LINE BREAK	MOD. KIT
	154166	154190 OR 195923	154141	154142	154147	164494	178808 WIRE PER 4312WD
LK6	●						
LK8							
LK9							
LK10							
LK11							
LK12							
LK13							
LK14							
LK15							
LK16							
LK18	NOTE 10						
LK28							
LK32							
LK37	NOTE 10						
LK39							
LK66							
LK67							

● DENOTES ITEM PRESENT

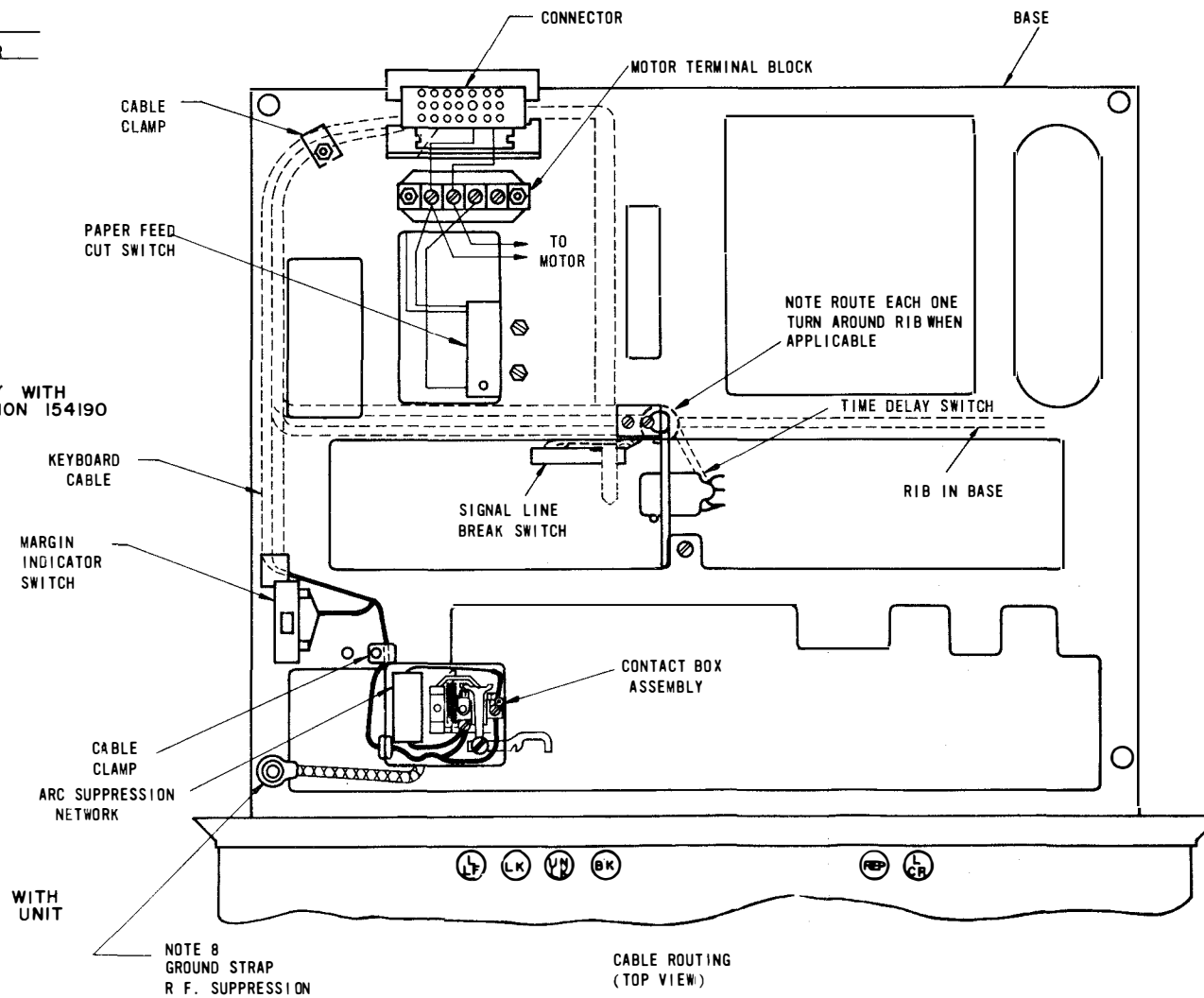

ACTUAL WIRING DIAGRAM FOR MODEL 28 KEYBOARD LK6, 8 AND UP (MARK III)

APPROVALS

D AND R	E OF M
<i>AKK</i>	<i>CM</i>

E-NUMBER

PROD. NO. 2928 WD

DATE 9 - 2 - 55

R.D. FILE NO. 2 - 18 .65AA

DRAWN *P* CHKD.

ENGD. JHB APPD.

TELETYPE CORPORATION

2928 WD

N2

NOTES (ENCIRCLED NUMBERS)

① POWER CIRCUITS WIRED FOR 115V A.C. OR D.C. OPERATION.

WIRE COLOR CODE:

BK	BLACK	BL	BLUE	W	WHITE
R	RED	Y	YELLOW	BR	BROWN
P	PURPLE	O	ORANGE	S	SLATE
G	GREEN	W-BK	WHITE BLACK	W-O	WHITE ORANGE
W-Y	WHITE YELLOW				
W-R	WHITE RED				

③ CONNECTOR & SWITCHES VIEWED FROM SOLDER TERMINAL ENDS.

④ ——— DENOTES BASIC WIRING.

----- DENOTES LEADS FURNISHED WITH ACCESSORY.

⑤ STRAP NECESSARY FOR OPERATION WITH LESU7.

⑥ POWER SWITCH SHOULD HAVE SLOT TOWARDS LEFT OR "OFF" SIDE.

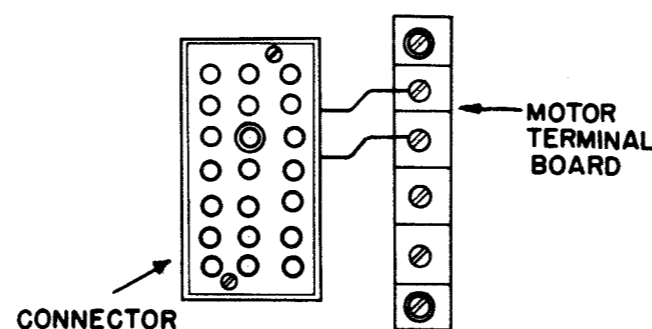

CONNECTOR

MOTOR TERMINAL BOARD

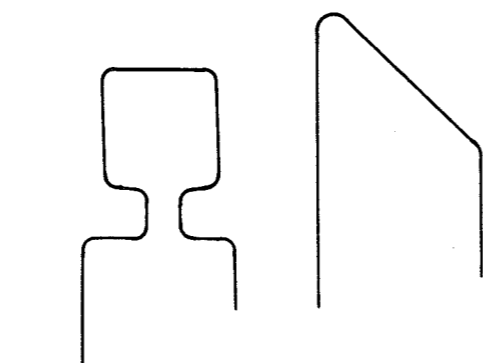

LB 9 CABLE ROUTING
(TOP VIEW)

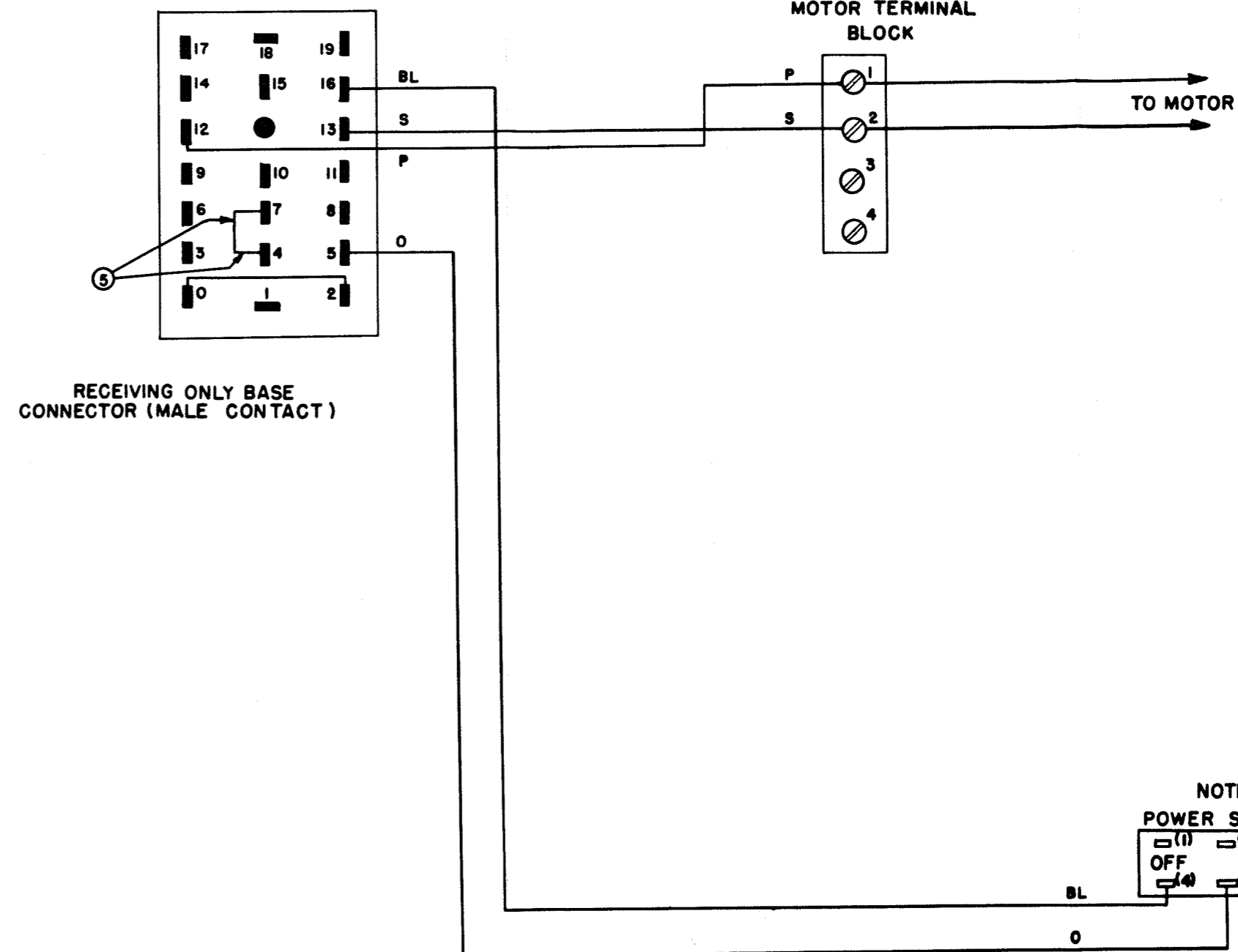

RECEIVING ONLY BASE
CONNECTOR (MALE CONTACT)

NOTE 6

POWER SWITCH

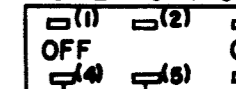

BL

O

3810 WD		
REVISIONS		
ISSUE	DATE	AUTH. NO.

APPROVALS

DATE: 10-12-59

RD. FILE NO. 15-30.28/85AA

DRAWN: A.B. CHKD: H.A.K.

ENGD. H.A.K. APPD. [Signature]

ACTUAL WIRING DIAGRAM MODEL 28

RECEIVING ONLY BASE

LB 9

ACCESSORY GROUP 146

DATE: 10-12-59

RD. FILE NO. 15-30.28/85AA

DRAWN: A.B. CHKD: H.A.K.

ENGD. H.A.K. APPD. [Signature]

TELETYPE CORPORATION

3810 WD

LB 9 RECEIVING ONLY BASE

- NO. NOTES
- POWER CIRCUITS WIRED FOR 115V AC OR DC OPERATION.
 - WIRE COLOR CODE:
 BK - BLACK BL - BLUE S - SLATE
 R - RED Y - YELLOW
 P - PURPLE O - ORANGE
 G - GREEN BR - BROWN
 - CONNECTORS VIEWED FROM SOLDER TERMINAL ENDS
 - STRAP NECESSARY FOR OPERATION WITH LESU7.
 - POWER SWITCH SHOULD HAVE SLOT TOWARDS FRONT OR "OFF" SIDE.

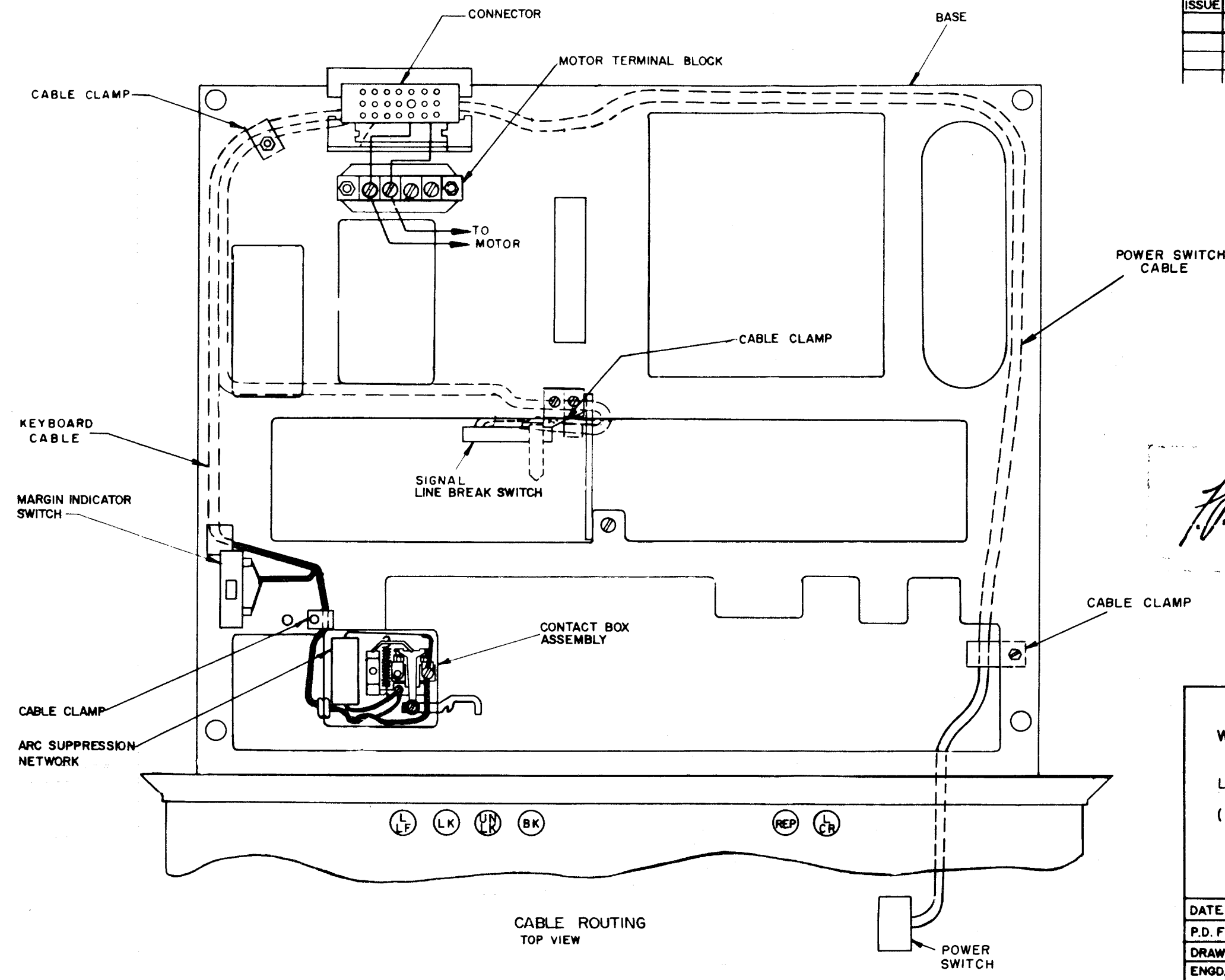
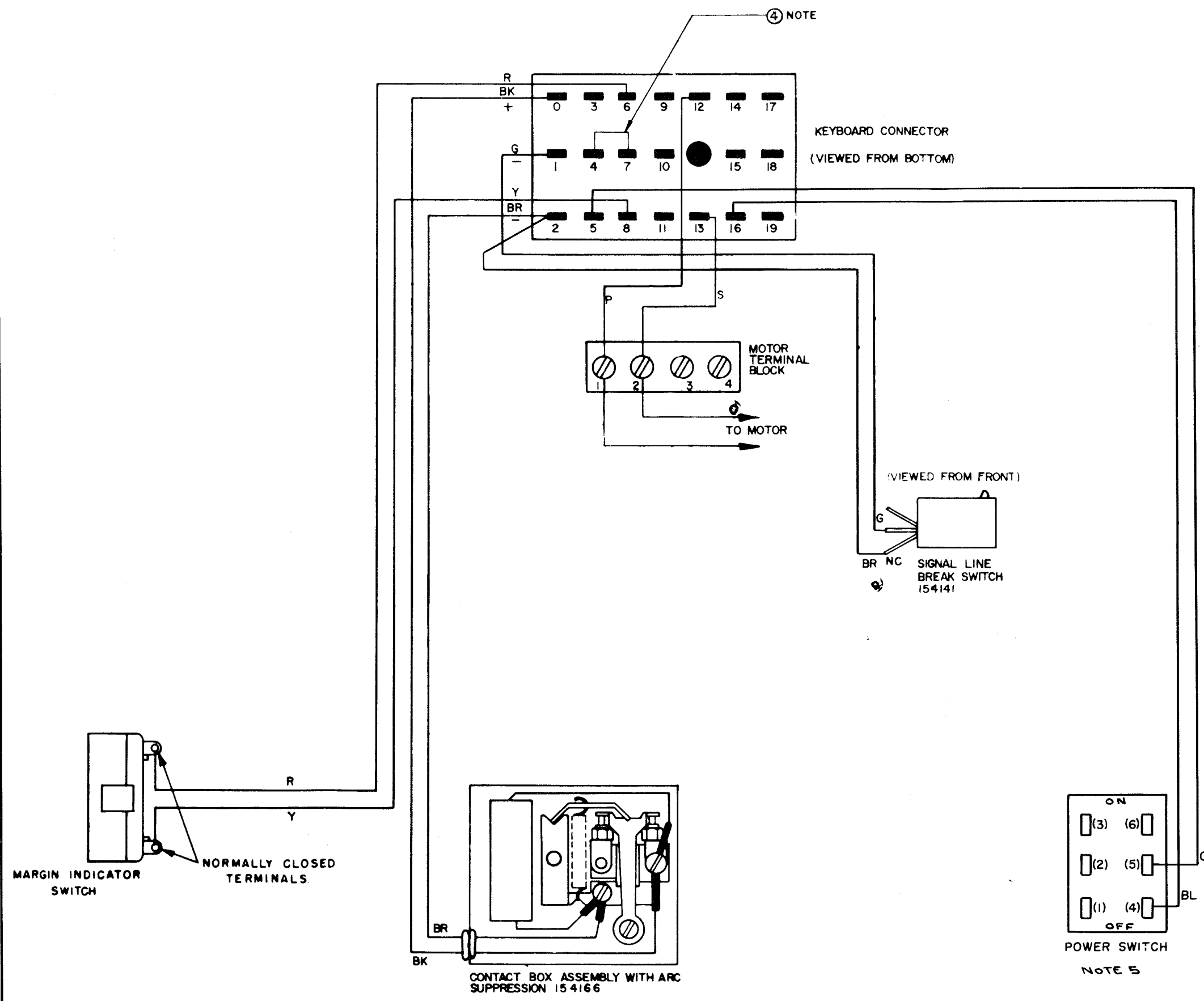

3814WD		
REVISIONS		
ISSUE	DATE	AUTH. NO.

ACTUAL WIRING DIAGRAM FOR MODEL 28 KEYBOARD LK 22 (MARK III)

DATE: 10-22-59
 P.D. FILE 15-30.28/65AA
 DRAWN: CHKD
 ENGD. HAK APPD: [Signature]
 TELETYPE CORPORATION
 3814WD

4343 WD		
REVISIONS		
ISSUE	DATE	AUTH. NO.
1	7-2-61	4343
2	8-20-61	4343
3	8-7-62	74022

NOTES

1. WIRING LEGEND
 DISTANT TERMINATING AREA
 DISTANT TERMINAL DESIGNATION
 WIRE COLOR CODE
 A-1-W-BK

2. COLOR CODES:
 BK - BLACK W-BK - WHITE - BLACK
 BR - BROWN W-BR - WHITE - BROWN
 R - RED W-R - WHITE - RED
 O - ORANGE W-O - WHITE - ORANGE
 Y - YELLOW W-Y - WHITE - YELLOW
 G - GREEN W-G - WHITE - GREEN
 B - BLUE W-BL - WHITE - BLUE
 P - PURPLE W-P - WHITE - PURPLE
 W - WHITE W-S - WHITE - SLATE
 S - SLATE

3. UNIT WIRED FOR 115 VOLTS A.C. OR D.C. POWER INPUT.

4. PLUGS VIEWED FROM SOLDER TERMINAL ENDS.

5. ALL CONTACTS SHOWN IN UNOPERATED POSITION IN KEYBOARD.

6.

7. ASSOCIATED CABLES:
 154149 (WITH 151329 SWITCH)
 154207
 154206
 176683

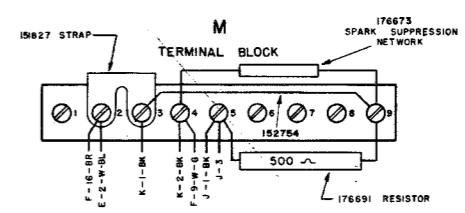
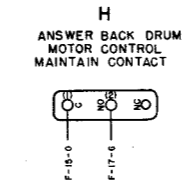
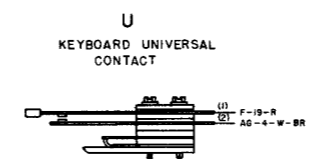
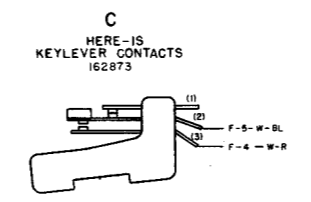
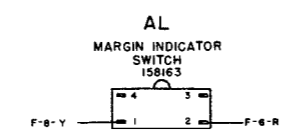
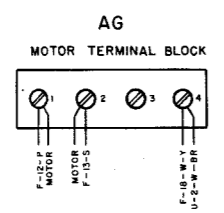
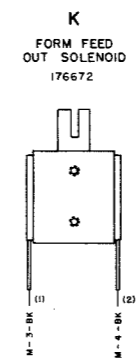
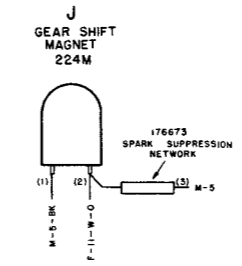
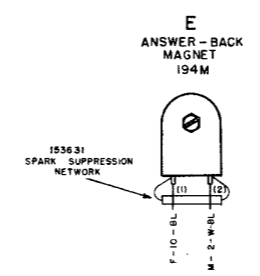
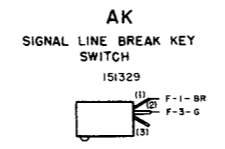
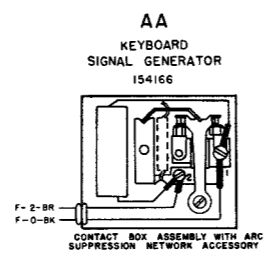
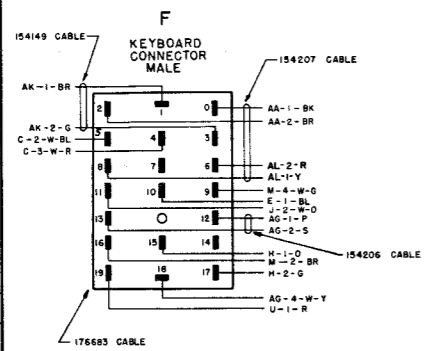

APPROVALS	
D AND S	E OF M
E NUMBER	
PROD NO 4343 WD	
ACTUAL WIRING DIAGRAM MODEL 28 KEYBOARD BASE LK26	
DATE: 1-4-61	
P.D. FILE NO. 22-485 228A	
DRAWN J.W.B. [Signature]	
ENGR. G.E.W. [Signature]	
TELETYPE CORPORATION	
4343 WD	

GREEN
BLUE
PURPLE
WHITE
SLATE

ATED 60 CYCLE ± 1% AC

TERMINAL ENDS.
OR DE-ENERGIZED

11 PLS.

BE ASSEMBLED TO
THE GROUND SCREW (TO MEET

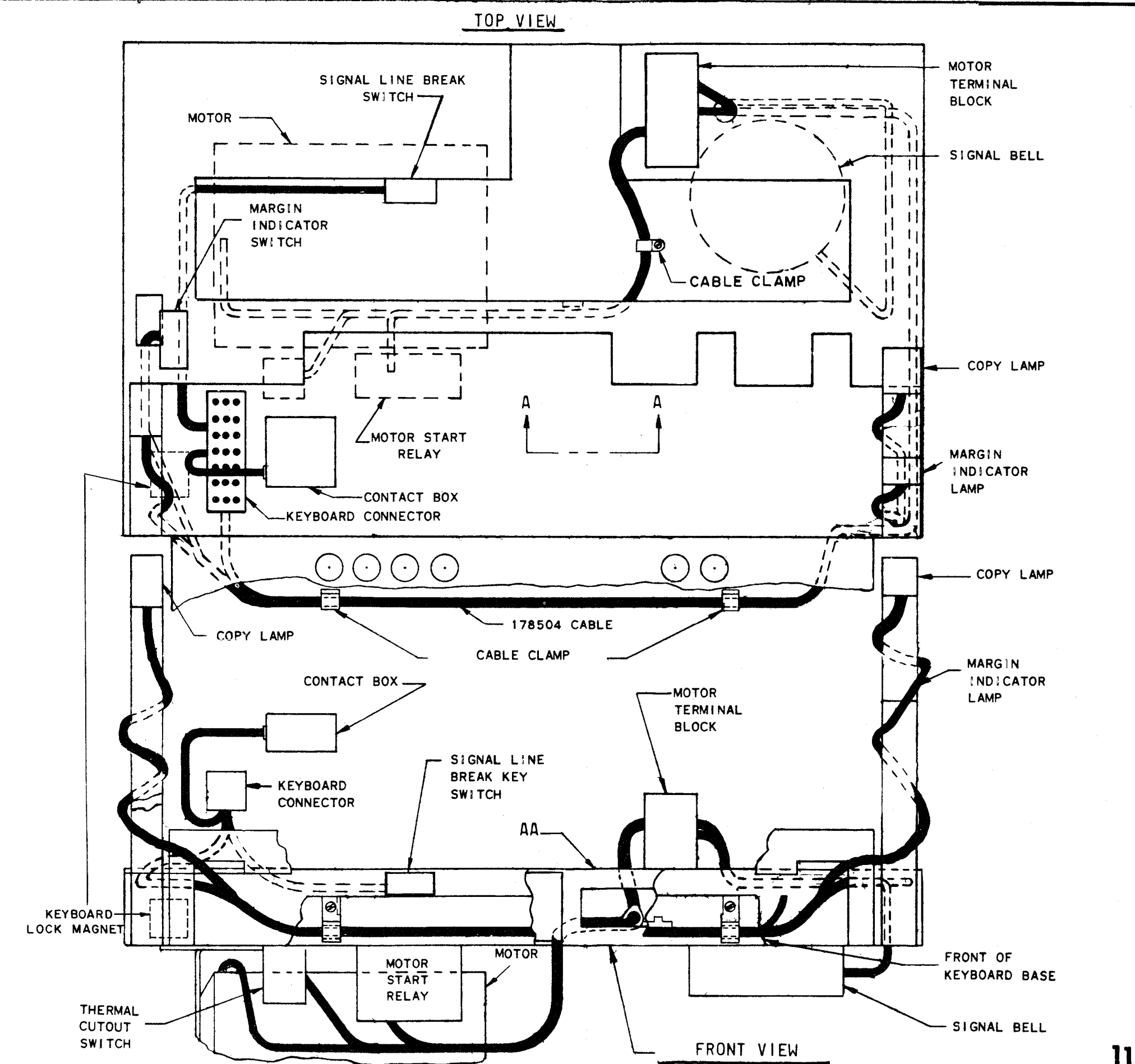
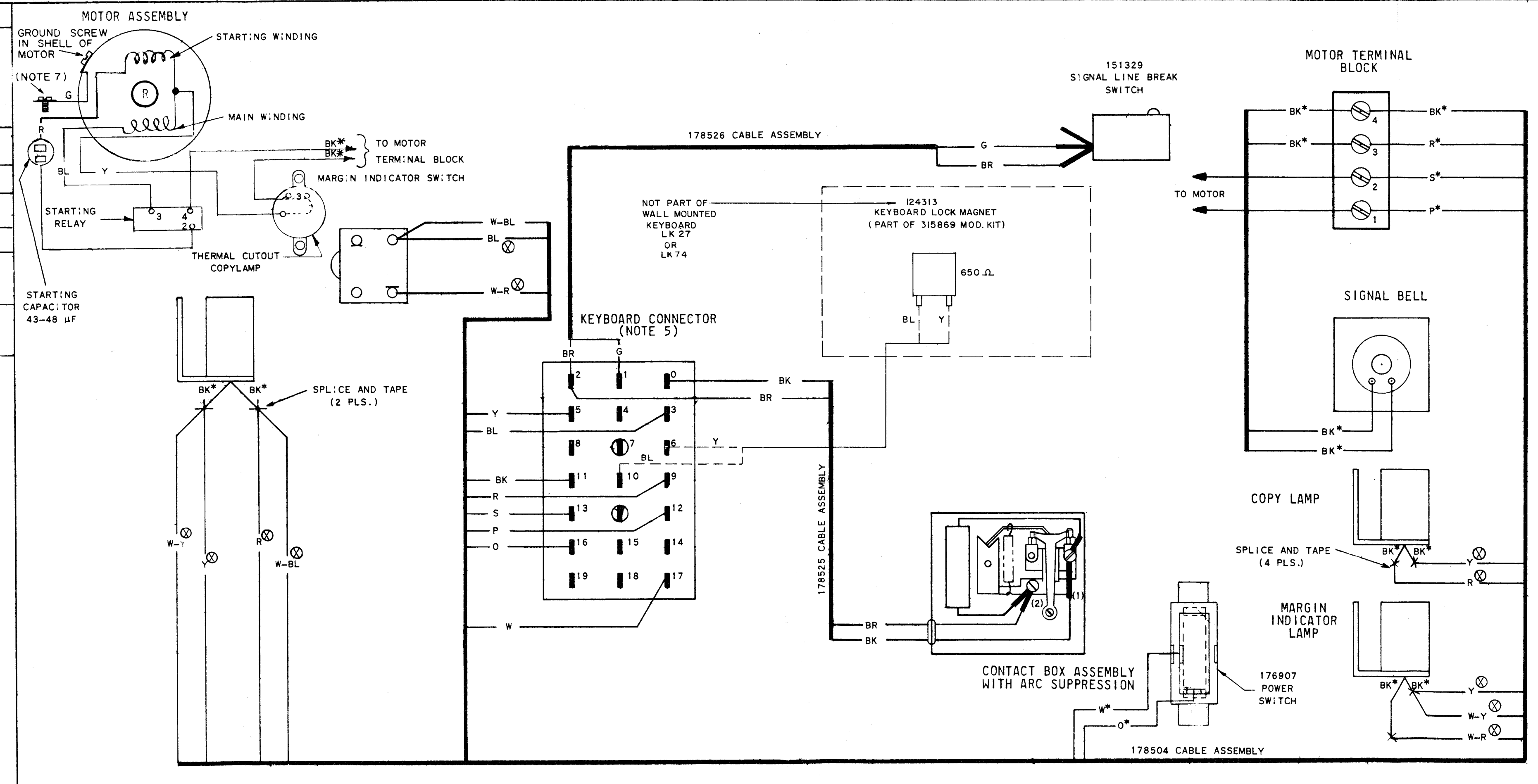

4484WD

REVISIONS

ISSUE	DATE	AUTH. NO.
8	5-28-63	76149
9	12-11-64	83843-1
10	6-29-66	87664-1
11	8-24-66	91437
12	5-27-68	95845

ACTUAL
WIRING DIAGRAM
FOR
MODEL 28
KEYBOARD BASE
LK27874
(WALL MOUNT)

APPROVALS

D AND R: E OF M

NUMBER

PROD. NO. 4484WD

DATE: 9-20-61

P.D. FILE NO.

DRAWN E.C.W. CHKD.

ENGD. B.P.K. APPD.

TELETYPE CORPORATION

4484WD

NO.	NOTES
1.	COLOR CODE BK - BLACK BR - BROWN R - RED O - ORANGE Y - YELLOW G - GREEN BL - BLUE P - PURPLE W - WHITE S - SLATE
2.	UNIT WIRED FOR 115 VOLTS REGULATED 60 CYCLE ± 1% AC POWER INPUT ONLY
3.	CONNECTORS VIEWED FROM SOLDER TERMINAL ENDS.
4.	CONTACTS SHOWN IN UN-OPERATED OR DE-ENERGIZED POSITION.
5.	USE 155753 INSULATING SLEEVES, 11 PLS.
6.	* = 18 GA. WIRE ⊗ = 22 GA. WIRE ALL OTHER LEADS 24 GA.
7.	MOTOR GROUND LEAD (GREEN) MUST BE ASSEMBLED TO MOUNTING FLATE USING A SEPARATE GROUND SCREW (TO MEET U.L. REQUIREMENTS).

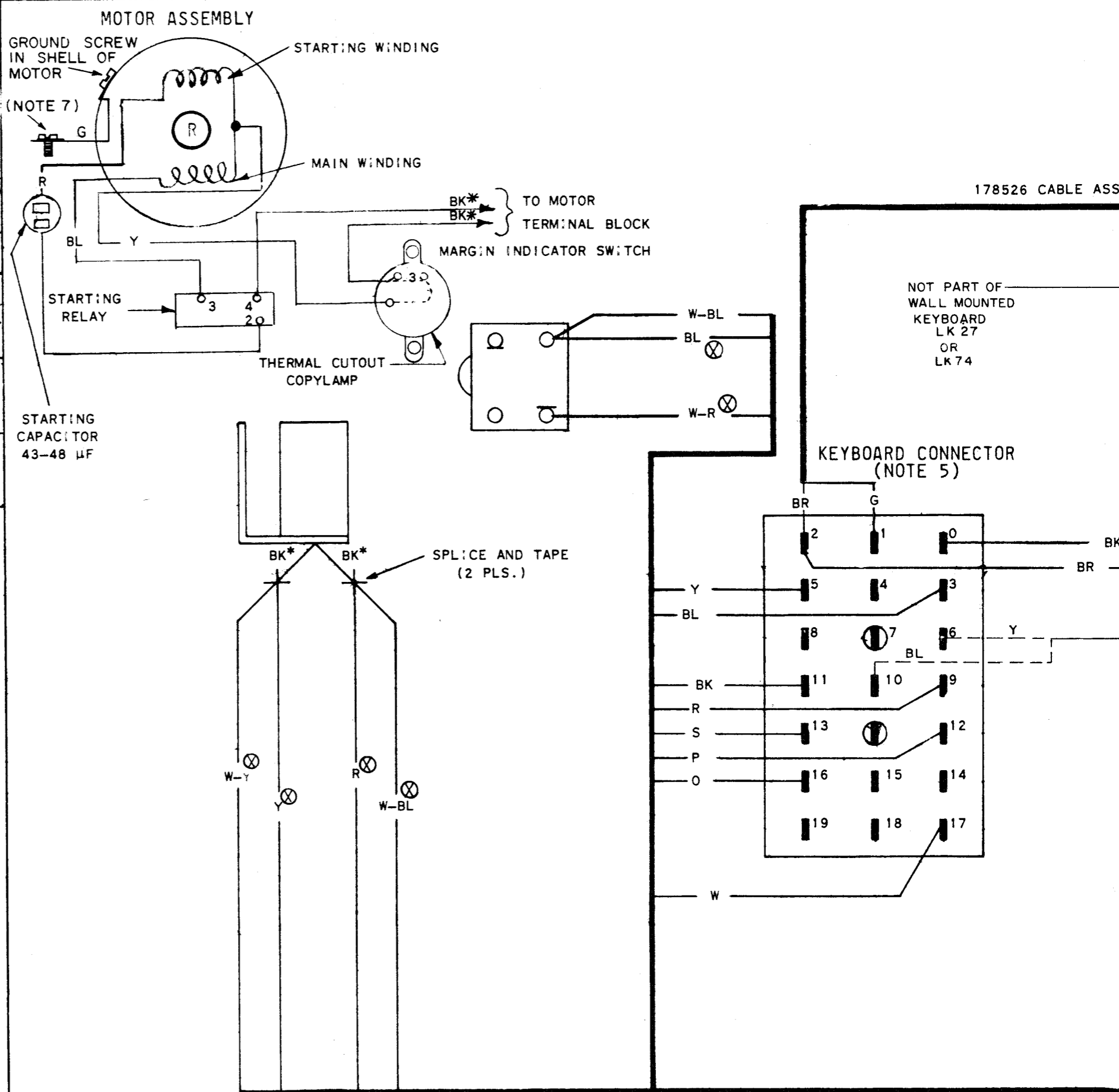

- NO. NOTES:**
- WIRING LEGEND:**
 DISTANT TERMINATING AREA
 DISTANT TERMINAL DESIGNATION
 A-I-W
 WIRING COLOR CODE
 - COLOR CODE:**
 BL - BLUE S - SLATE
 BR - BROWN Y - YELLOW
 R - RED G - GREEN
 P - PURPLE
 - CONNECTOR VIEWED FROM SOLDERED TERMINAL END.
 - THE NUMBERS ENCLOSED BY PARENTHESES ARE USED FOR REFERENCES AND ARE NOT NECESSARILY SHOWN ON THE PARTS
 - FOR ASSOCIATED SCHEMATIC WIRING DIAGRAM SEE 4900WD AND 4918WD
 - FOR LK 46 AND 47, ADD DASHED (---) CONNECTIONS AND OMIT CONNECTIONS MARKED (---X---) IN MOTOR POWER CIRCUITS.
 - NEW STYLE SWITCH (309507) SHOWN. EARLIER VERSION IS 162873 SWITCH.

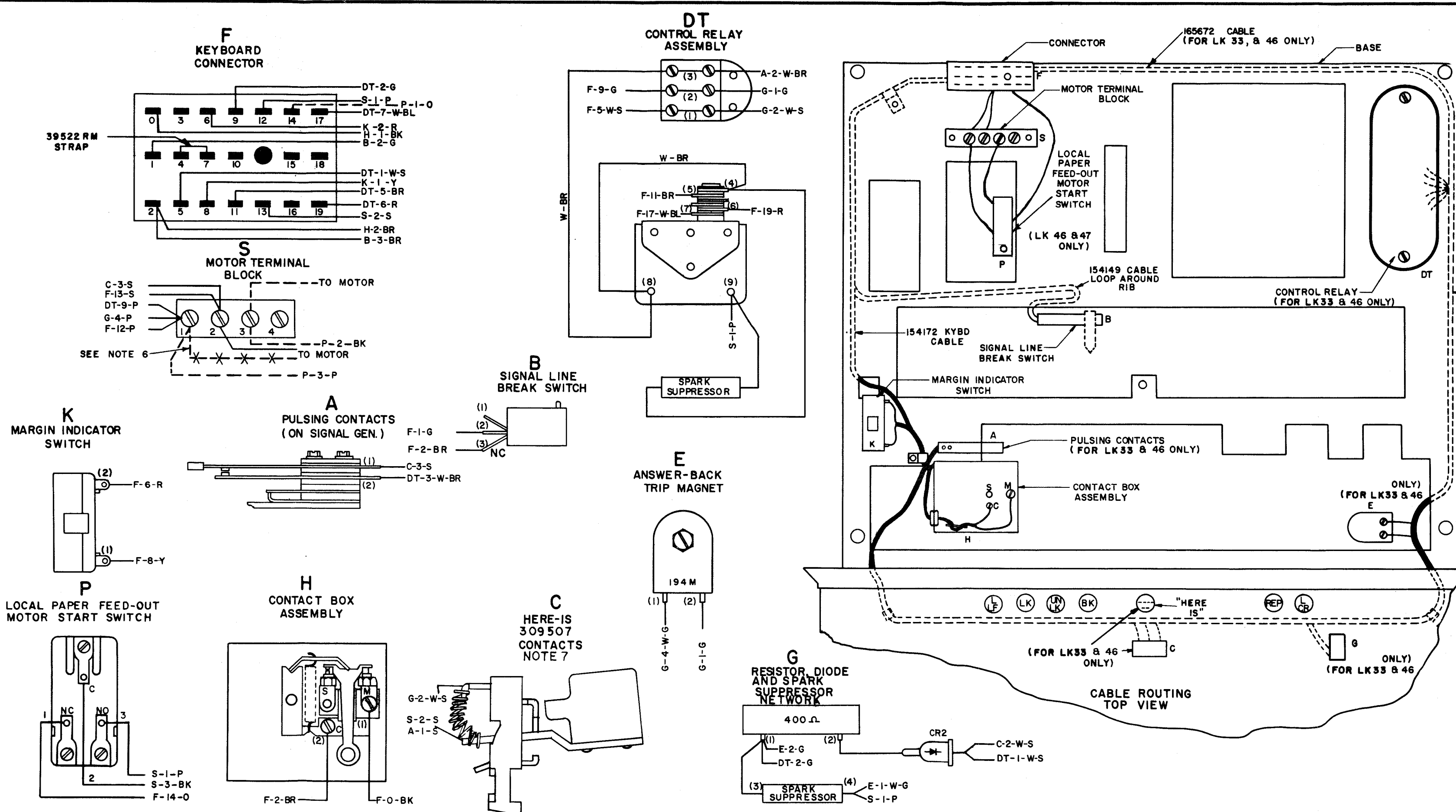

4906 WD		
REVISIONS		
ISSUE	DATE	AUTH. NO.
1	11-29-62	75189
2	7-31-63	77270
3	1-29-64	79231
4	5-23-67	888322

178341 CABLE (FOR LK 33 & 46 ONLY)

ACTUAL WIRING DIAGRAM FOR MODEL 28 LK 33, 34, 46, 47 (MARK III)

APPROVALS
 D AND R E OF M

E-NUMBER
 PROD. NO. 4906 WD

DATE: 11-11-61
 PD. FILE NO. 5-A100AA
 DRAWN E.M. CHKD.
 ENGD. T.D.C. APPD.

TELETYPE CORPORATION
 4906 WD

NO.	NOTES
1.	COLOR CODE: BK - BLACK BR - BROWN R - RED O - ORANGE Y - YELLOW G - GREEN BL - BLUE P - PURPLE W - WHITE S - SLATE
2.	UNIT WIRED FOR 115 VOLTS REGULATED 60 CYCLE (± 1%) AC POWER INPUT ONLY.
3.	CONNECTORS VIEWED FROM SOLDER TERMINAL ENDS.
4.	CONTACTS SHOWN IN UN-OPERATED OR DE-ENERGIZED POSITION.
5.	MOTOR GROUND LEAD (GREEN) MUST BE ASSEMBLED TO MOUNTING PLATE USING A SEPARATE GROUND SCREW (TO MEET U.L. REQUIREMENTS).

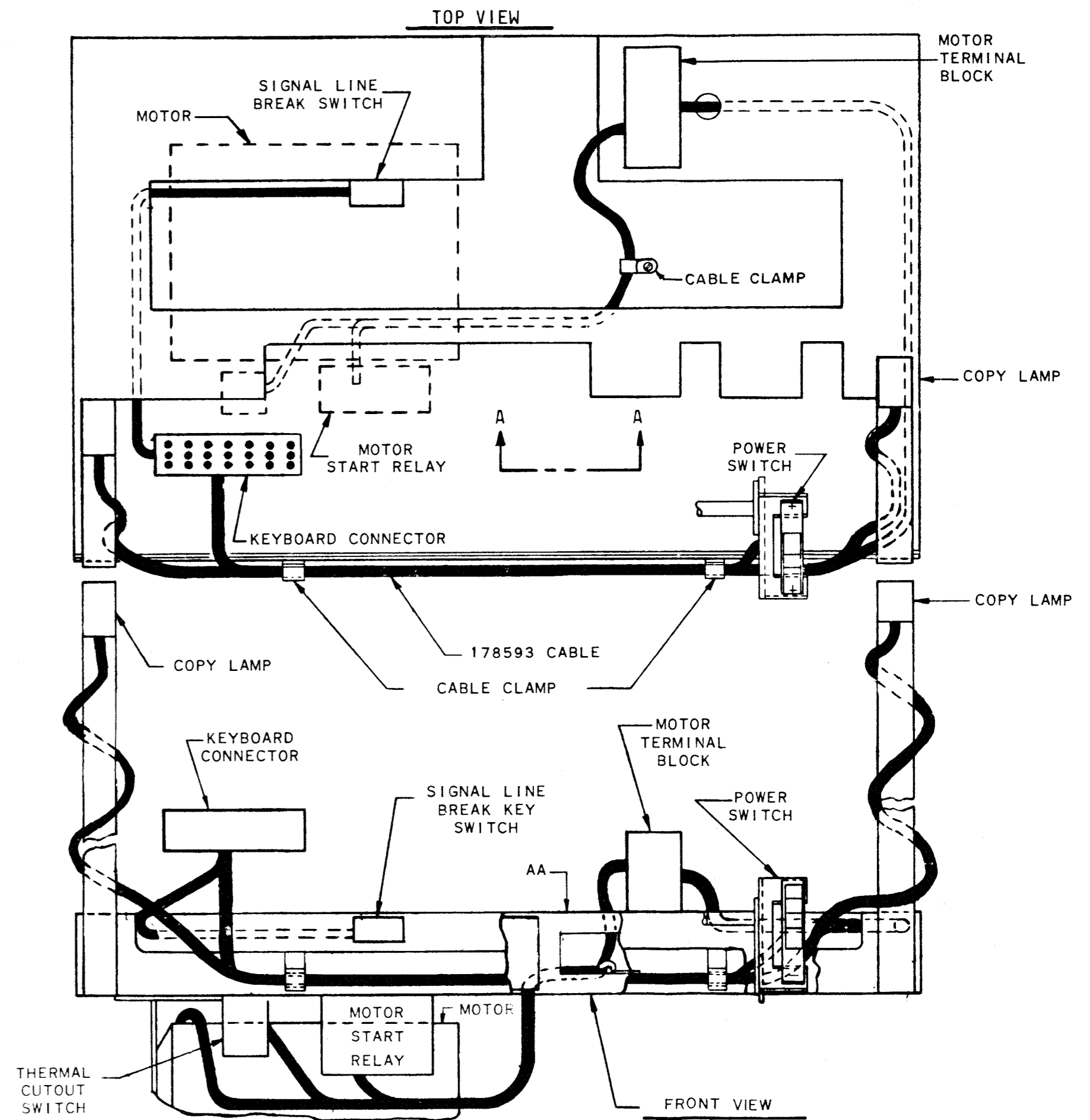
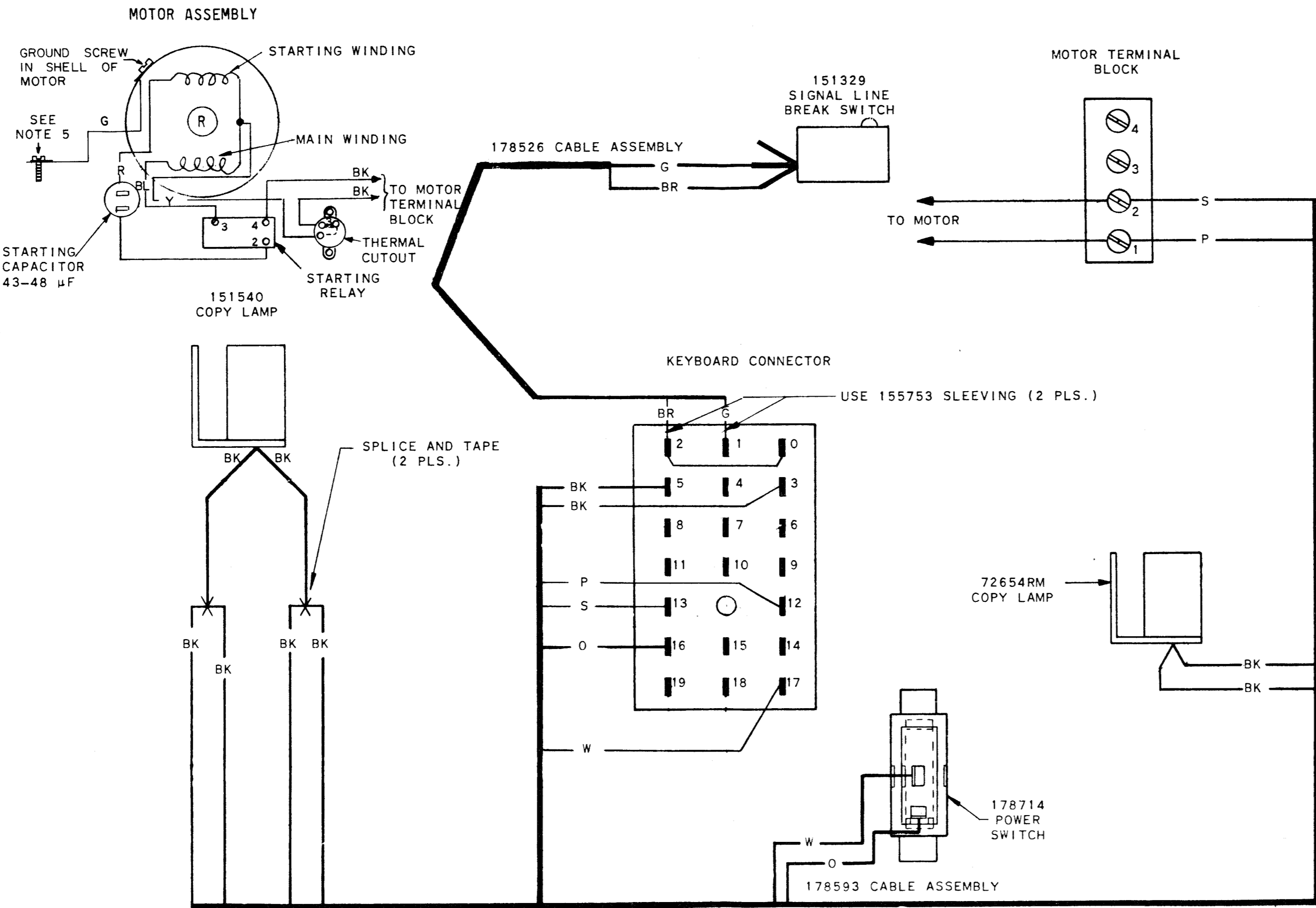

5860WD		
REVISIONS		
ISSUE	DATE	AUTH. NO.
25	5-28-63	76149
6	12-11-64	83843-1
7	6-29-66	87664-1





ACTUAL WIRING DIAGRAM FOR MODEL 28 R.O. BASE LB31 (WALL MOUNT)

APPROVALS	
D AND R	E OF M
E-NUMBER	
PROD. NO.	
DATE:	
P.O. FILE NO. 66-30.65AA	
DRAWN E.C.W.	CHKD
ENGD.	APPD.
TELETYPE CORPORATION	
5860WD	

6486 WD

REVISIONS

ISSUE	DATE	AUTH. NO.
A2	4-23-64	79225-3

- NO. NOTES**
- POWER CIRCUITS WIRED FOR 115V AC OPERATION.
 - WIRE COLOR CODE:
BK - BLACK BL - BLUE
BR - BROWN R - RED
Y - YELLOW S - SLATE
P - PURPLE O - ORANGE
G - GREEN W - WHITE
 - CONNECTORS VIEWED FROM SOLDERED TERMINAL ENDS.
 - STRAP NECESSARY FOR OPERATION WITH LESU107.
 - GROUND STRAP TERMINATES AT TOP OF BASE LOWER PLATE BY MEANS OF LEFT FRONT 151549 KEYBOARD SPECIAL MOUNTING SCREW.
 - TERMINAL DESIGNATIONS SHOWN IN PARENTHESES ARE FOR REFERENCE AND ARE NOT MARKED ON COMPONENT.
 -  SHIELDED CABLE
 - FOR PROPER R.F. FILTERING, POLARITY MUST BE MAINTAINED WHEN 154190 FILTER IS USED. UNIT AS FURNISHED IS WIRED FOR "MARKING" CONTACT POSITIVE (+), "SPACING" CONTACT NEGATIVE (-). TO REVERSE THE POLARITY ON CONTACTS SO THAT THE "MARKING" CONTACT IS NEGATIVE (-) AND THE "SPACING" CONTACT POSITIVE (+). MAKE THE FOLLOWING CONNECTIONS IN THE CONTACT BOX ASSEMBLY:
1. MOVE BLACK LEAD FROM BOTTOM FILTER FROM "MARKING" CONTACT TO "SPACING" CONTACT.
2. MOVE GREEN LEAD OF TOP FILTER FROM "SPACING" CONTACT TO "MARKING" CONTACT.
POLARITY MAY BE DISREGARDED WHEN UNITS ARE FURNISHED WITH 195923 FILTERS.
 - WIRING LEGEND
 DISTANT TERMINATING AREA
 DISTANT TERMINATING DESIGNATION
F-2-BR
 WIRE COLOR CODE

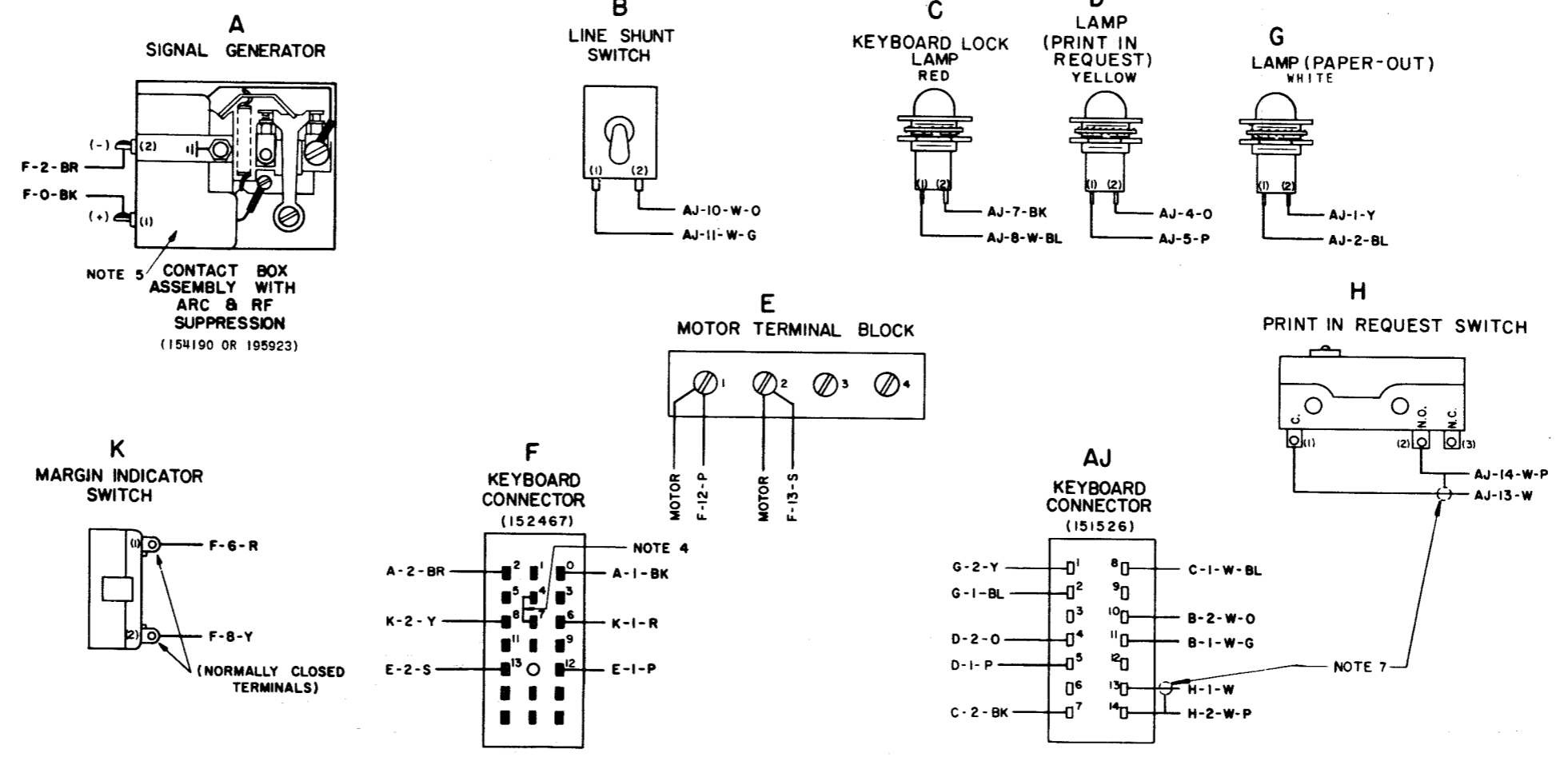

ACTUAL WIRING DIAGRAM FOR MODEL 28 KEYBOARD LK

APPROVALS

D AND R	E OF M
-----	-----

E-NUMBER

PROD. NO. 6486WD

DATE 6-8-63

P.D. FILE NO. 25-A65.219A

DRAWN E.M. CHKD. F.M.

ENGD. J.C.F. APPD.

TELETYPE CORPORATION

6486 WD

ISSUE	DATE	AUTH. NO.
2	1-18-65	85607
3	5-3-65	87039

- NO. NOTES
- WIRE COLOR CODE
BR-BROWN S - SLATE
R- RED W - WHITE
O- ORANGE P - PURPLE
G - GREEN BL- BLUE
BK- BLACK
 - CONNECTOR VIEW FROM TERMINAL END
 - BARE WIRE STRAP 3922RM
 - ASSOCIATED CABLES:
154172 KEYBOARD CABLE
304611 SWITCH CABLE ASSEMBLY
154149 SIG. LINE BREAK SWITCH CABLE
 - FOR SCHEMATIC SEE 7157 WD
 - TERMINAL DESIGNATIONS ENCLOSED IN PARENTHESES ARE NOT MARKED ON THE COMPONENT
 - WIRING LEGEND:

DISTANT TERMINATING AREA
DISTANT TERMINATING DESIGNATION
A-1-W-BK
WIRE COLOR CODE

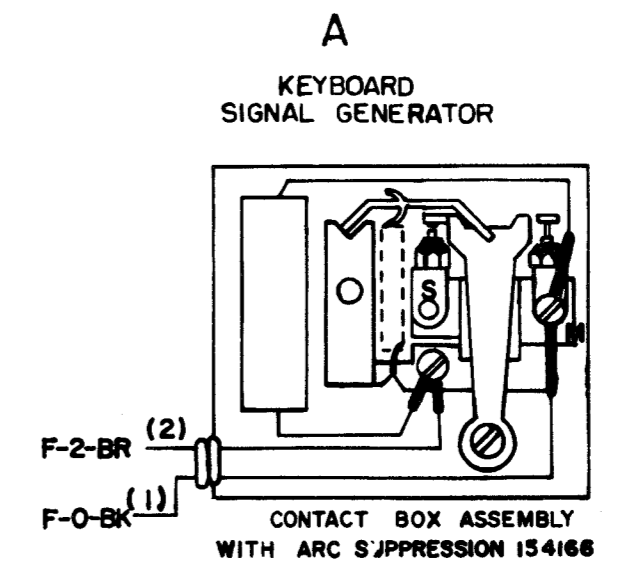
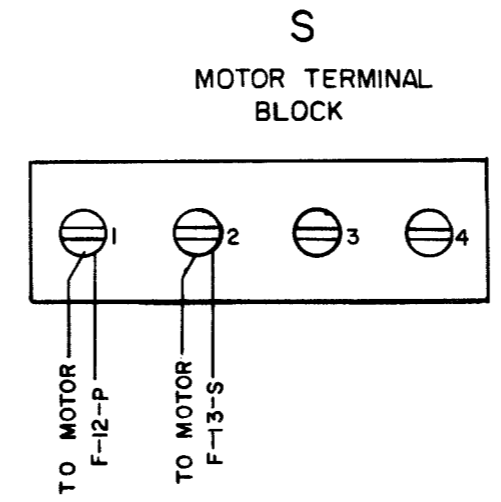
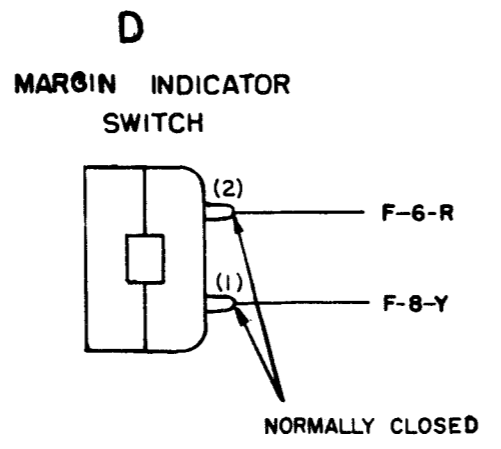
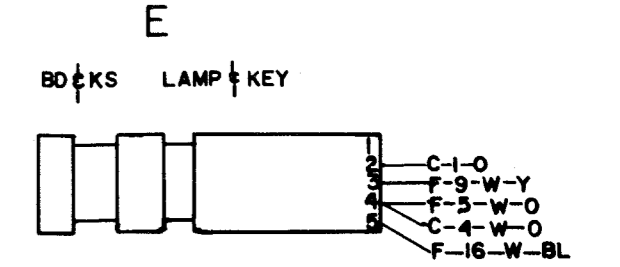
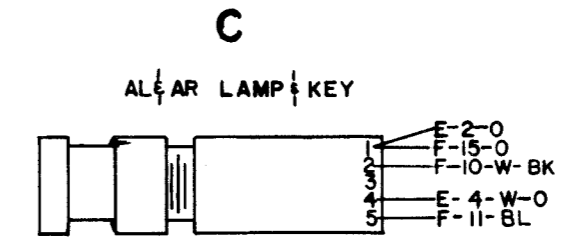
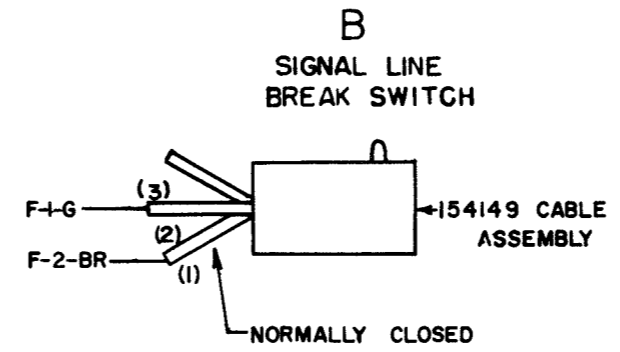
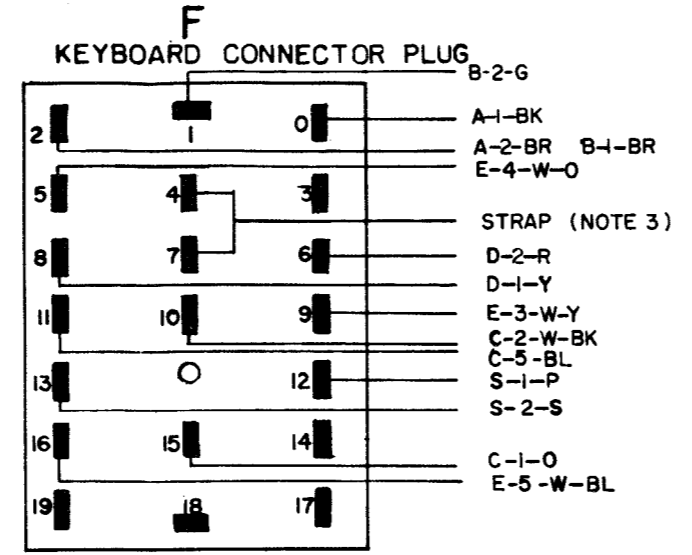

ACTUAL WIRING DIAGRAM MODEL 28 KEYBOARD LK 50

APPROVALS

DANDR <i>[Signature]</i>	E OF M <i>[Signature]</i>
E-NUMBER 7160 WD	
PROD NO. WD	
DATE: 2-20-64	
P.D. FILE NO 11-A25AA	
DRAWN RAL	CHKD <i>[Signature]</i>
ENGD. F.G.H.	APPD. <i>[Signature]</i>

TELETYPE CORPORATION
7160 WD